

AD-A089 317

MITRE CORP MCLEAN VA METREK DIV F/G 1/2
FEASIBILITY OF A SEPARATE SHORT RUNWAY FOR COMMUTER AND GENERAL--ETC(U)
MAY 80 J D GARNER DOT-FA80WA-4370
MTR-80W00034 NL

UNCLASSIFIED

FAA-EM-80-4

END
DATE
FILMED
10 80
DTIC

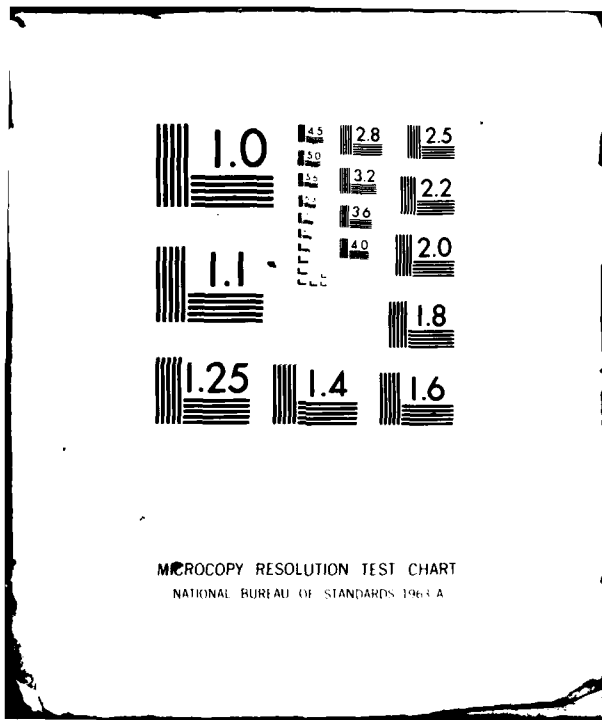

MICROCOPY RESOLUTION TEST CHART
NATIONAL BUREAU OF STANDARDS 1963 A

Report No. FAA-EM-88-4

LEVEL 

12
P.S.

AD A089317

FEASIBILITY OF A SEPARATE SHORT RUNWAY FOR COMMUTER AND GENERAL AVIATION TRAFFIC AT DENVER



DTIC
ELECTE
SEP 22 1980
S **D**
C

MAY 1980

Document is available to the U.S. public through
the National Technical Information Service,
Springfield, Virginia 22161

Prepared for

U.S. DEPARTMENT OF TRANSPORTATION
FEDERAL AVIATION ADMINISTRATION
OFFICE OF SYSTEMS ENGINEERING MANAGEMENT
Washington, D.C. 20501

DDO FILE COPY

80 9 19 002

NOTICE

This document is disseminated under the sponsorship of the Department of Transportation in the interest of information exchange. The United States Government assumes no liability for its contents or use thereof.

1. Report No. 18 FAA-EM-80-4 ✓		2. Government Accession No. AD-A089 317		3. Recipient's Catalog No.	
4. Title and Subtitle Feasibility of a Separate Short Runway for Commuter and General Aviation Traffic at Denver				5. Report Date May 1980	
7. Author(s) John D. Garner				8. Performing Organization Report No. 14 MTR-80W0034	
9. Performing Organization Name and Address The MITRE Corporation Metrek Division ✓ 1820 Dolley Madison Boulevard McLean, VA. 22102				10. Work Unit No. (TRAFS) 471	
12. Sponsoring Agency Name and Address Department of Transportation Federal Aviation Administration Office of Systems Engineering Management Washington, DC 20591				11. Contract or Grant No. 1 DOT-FA80WA-4370 ✓	
15. Supplementary Notes				13. Type of Report and Period Covered	
16. Abstract An analysis is made of the feasibility of a short, separate runway for general aviation at Denver's Stapleton International Airport and how it may be facilitated by FAA Engineering and Development products. General aviation is defined as private, corporate, and fixed base operators (flight schools and air taxis), and commuter airlines. The analysis is for Instrument Meteorological Conditions using current ATC procedures and consists of: runway placement, obstacle clearance, location of navigational aids, airspace design to segregate aircraft by type to two separate parallel runways, and the design of taxi patterns to allow unimpeded movement of ground traffic. Details of ILS siting such as terrain and multipath problems are not addressed.				14. Sponsoring Agency Code AEM-100	
17. Key Words Denver, Short Runway, Commuter, General Aviation, Airport Capacity, Parallel Approaches, ILS Approaches, MLS			18. Distribution Statement Document is available to the public through the National Technical Information Service, Springfield, VA 22161		
19. Security Classif. (of this report) Unclassified		20. Security Classif. (of this page) Unclassified		21. No. of Pages	22. Price

CONCLUSIONS AND RECOMMENDATIONS

The preliminary analysis indicates that the proposed commuter/general aviation runway is feasible. It offers benefits in terms of increased capacity and reduced delay to Denver's Stapleton International Airport. These projected benefits may be reduced if fewer general aviation (GA) aircraft than forecast can use the new runway because of its short length.

The noise generated by traffic approaching to the north or executing a missed approach either to the north or to the south may be an important issue, but is beyond the scope of this study.

A Microwave Landing System may be required for the proposed runway because of uneven terrain. This would require new equipment in general aviation aircraft, the segment of the industry that traditionally equips last.

It is important that excess airside demand not be translated into excess groundside demand. An additional access to the terminal apron should be built west of taxiways Z-1 and L-3. It is further recommended that as many GA operations as practical be moved adjacent to the new runway and that an overpass across I-70 for GA aircraft be considered.

Other issues such as land availability for navigational aids, critical areas, or clear zones, and the expansion of the Terminal Control Area appear not to pose any insurmountable problems.

Accession For	
NTIS GRA&I	<input checked="" type="checkbox"/>
DOC TAB	<input type="checkbox"/>
Unannounced Justification	
By _____	
Distributor/_____	
Availability Codes	
Dist	Avail and/or special
A	

TABLE OF CONTENTS

	<u>Page</u>
1. INTRODUCTION	1-1
1.1 Background	1-1
1.2 Objective	1-1
1.3 Selection Of Denver For The Site-Specific Study	1-1
1.4 Elements Of The Analysis	1-3
2. DENVER CHARACTERISTICS	2-1
2.1 Current Layout And Operations	2-1
2.2 New Runway And Taxiway Placement	2-3
2.3 Potential Capacity Benefits	2-3
3. OBSTACLE CLEARANCE	3-1
3.1 Physical Limits On Runway Placement	3-1
3.2 Effects Of Runway Length	3-1
3.3 Potential Obstacle Clearance Problems	3-3
4. CRITICAL AREAS, NO PARKING AREAS, AND SITING REQUIREMENTS	4-1
5. AIRSPACE DESIGN	5-1
5.1 Design Criteria	5-1
5.2 Configuration Analysis	5-2
5.2.1 Landings And Departures To The North	5-2
5.2.2 Landings To The South And Departures To The East	5-4
5.3 Airspace Problems	5-8
5.3.1 Noise Impact	5-8
5.3.2 Missed Approaches	5-8
5.3.3 Terminal Control Area	5-13
6. GROUND SIDE DESIGN	6-1
6.1 Design Criteria For Taxiways And The Terminal Apron	6-1
6.2 Configuration Analysis	6-1
6.2.1 Landings And Departures To The North	6-1
6.2.2 Landings To The South And Departures To The East	6-4
6.3 Groundside Problems	6-4

	<u>Page</u>
7. CONCLUSIONS AND RECOMMENDATIONS	7-1
APPENDIX A: INSTALLATION COST ESTIMATES	A-1
APPENDIX B: REFERENCES	B-1

LIST OF ILLUSTRATIONS

	<u>Page</u>
TABLE 1-1: OPERATIONAL CHARACTERISTICS OF AIRPORTS WITH POTENTIAL BENEFITS FROM A SEPARATE GENERAL AVIATION RUNWAY	1-2
TABLE 2-1: DENVER IFR CAPACITY IN OPERATIONS PER HOUR	2-7
FIGURE 2-1: DENVER AIRPORT LAYOUT	2-2
FIGURE 2-2: PROPOSED DENVER AIRPORT LAYOUT	2-4
FIGURE 2-3: DENVER 1985 DEMAND VERSUS IFR CAPACITY	2-5
FIGURE 3-1: RUNWAY 18/36 OBSTACLE CLEARANCES	3-2
FIGURE 4-1: RUNWAY 36 CRITICAL AND NO PARKING AREAS	4-2
FIGURE 4-2: RUNWAY 18 CRITICAL AND NO PARKING AREAS	4-3
FIGURE 5-1: RECENT ILS PROCEDURE LANDING NORTH, TAKEOFF NORTH	5-3
FIGURE 5-2: PROPOSED ILS PROCEDURES LANDING NORTH, TAKEOFF NORTH	5-5
FIGURE 5-3: RECENT LOC (BACK CRS) PROCEDURE LANDING SOUTH, TAKEOFF EAST	5-6
FIGURE 5-4: PROPOSED ILS PROCEDURES LANDING SOUTH, TAKEOFF EAST	5-7
FIGURE 5-5: PLAN VIEW OF RADAR TURN-ON TO ILS (160 KTS)	5-9
FIGURE 5-6: TURN-ON PRIORITY STRATEGY	5-10
FIGURE 5-7: MISSED APPROACHES OVER P-26	5-12
FIGURE 5-8: CURRENT DENVER TERMINAL CONTROL AREA	5-14
FIGURE 6-1: CURRENT TAXI PATTERNS LANDING NORTH, TAKEOFF NORTH	6-2
FIGURE 6-2: PROPOSED TAXI PATTERNS LANDING NORTH, TAKEOFF NORTH	6-3
FIGURE 6-3: CURRENT TAXI PATTERNS LANDING SOUTH, TAKEOFF EAST	6-5
FIGURE 6-4: PROPOSED TAXI PATTERNS LANDING SOUTH, TAKEOFF EAST	6-6

1. INTRODUCTION

1.1 Background

In the 1980's and 1990's many airports will have insufficient capacity during Instrument Meteorological Conditions (IMC) to accommodate forecast arrivals and departures. One approach to providing additional airport capacity is to use a separate short runway for general aviation (GA) operations: GA being defined as private, corporate, and fixed base operators, and commuter airlines. Benefits occur in two forms: increased GA capacity on the new runway and increased air carrier capacity on the existing runway because a more homogeneous mix of traffic on approach reduces wake vortex separation requirements.

The purpose of the overall project is to determine the potential benefits of this concept at the top 30 air carrier airports and the need for Engineering and Development (E&D) products to facilitate such an operation. The first phase of this study (Reference 1) determined that benefits may be achievable at eleven of the thirty airports. The airports, modifications, and types of operation are given in Table 1-1. Expressed in 1980 dollars, discounted at 10%, the estimated benefits for the eleven airports between 1980 and 1990 ranged from \$450 million to \$810 million, depending on the demand scenario. The benefits were not evenly distributed among airports: Chicago, Atlanta, Philadelphia, and Denver received 80-85% of the benefits; or among users, certificated air carriers received 86-89% of the benefits because of their higher operating costs.

1.2 Objective

The purpose of this report is to conduct a site-specific study to analyze the feasibility and identify the potential problems of using a separate, short general aviation runway at one of the eleven airports. The study also seeks to determine how current E&D products might facilitate such an operation.

1.3 Selection Of Denver For The Site-Specific Study

Based on the Phase I analysis, the primary candidates for the site-specific study were O'Hare, Atlanta, Philadelphia, and Denver. In the proposed scenarios, O'Hare and Atlanta required triple parallel approaches. The operational implications of triple parallel approaches are currently being investigated by MITRE under the sponsorship of the FAA's

TABLE 1-1

OPERATIONAL CHARACTERISTICS OF AIRPORTS WITH POTENTIAL BENEFITS
FROM A SEPARATE GENERAL AVIATION RUNWAY

MODIFICATION	PARALLEL INDEPENDENT OPERATIONS	PARALLEL DEPENDENT OPERATIONS	NON-PARALLEL DEPENDENT OPERATIONS
NEW RUNWAY	CHICAGO ³ , ATLANTA ³ DALLAS-FT. WORTH ³ , DENVER	PHILADELPHIA PITTSBURGH ^{1,2}	
EXISTING RUNWAY OR TAXIWAY		DETROIT ^{1,2}	PORTLAND, ST. LOUIS
EXTENSION OF EXISTING RUNWAY		NEW YORK (JFK) ¹ INDIANAPOLIS	

¹THE GA RUNWAY IS INDEPENDENT OF ONE OF TWO AIR CARRIER RUNWAYS FOR DEPARTURES.

²GA RUNWAY HANDLES DEPARTURES ONLY.

³TRIPLE PARALLEL RUNWAYS.

Office of Systems Engineering Management. Denver has an on-going Airport Improvement Task Force, consisting of airlines, ATA, airport sponsors and FAA representatives, that has expressed interest in a separate GA runway at Denver. Furthermore, MITRE has knowledge of the current Denver operations, therefore, Denver was selected for the site-specific analysis.

1.4 Elements Of The Analysis

Specific topics addressed in this analysis include: siting of the runway, taxiways, and navigational aids, obstacle clearance, airspace design to segregate aircraft by type to two separate parallel runways, and the design of taxi patterns.

2. DENVER CHARACTERISTICS

2.1 Current Layout And Operations

The physical layout of Stapleton International Airport (Denver) is shown in Figure 2-1. Denver is currently operating three north-south runways: 17R/35L, 17L/35R, and 17C/35C. Runway 17C/35C is restricted to day, Visual Flight Rules (VFR) operation of propeller aircraft less than 12,500 pounds Gross Take-Off Weight (GTOW). Runways 35L and 35R both have full Instrument Landing Systems (ILS's), but they are dependent for arrivals and departures during IMC because they are separated by only 1600 feet. Landings to the south in IMC have been on runway 17R using a Localizer Back-Course approach.¹

There are three east-west runways at Denver runways 8L/26R, 8R/26L, and 7/25. Runway 7/25 is restricted to day, VFR operations of aircraft less than 12,500 GTOW. Runway 26L has a full ILS and 26R is not served by a precision approach. Landings to the east during IMC are on runway 8R which has a full ILS Back-Course approach.

Denver conducts 5.4% of its operations in IMC. For IMC conditions, runway configurations and percent of total operations are: arrivals runway 26L and departures runways 35L/35R--3.8%, arrivals and departures runways 35L/35R--0.5%, arrivals runways 17L/17R and departures runways 8L/8R--0.7%, arrivals runways 8L/8R and departures runways 35L/35R--0.4% (Reference 3). Even though runways 8L and 17L have lacked instrument approaches, the weather might be such that aircraft could be shifted, after breaking-out, to these runways.

Denver has a formal runway use program for noise abatement. Air traffic control personnel have agreed to follow the program whenever possible to protect the noise sensitive areas south and west of the airport. In order of decreasing preference, the runways favored are: for departures--35, 8, 17, and 26, and, for arrivals--26 or 17 and 35 or 8 (Reference 2). The most commonly used IFR configuration, arrivals on runway 26L and departures on runways 35L/35R, conforms to the preferred runway program for noise abatement.

¹ An ILS has recently been commissioned on 17L.

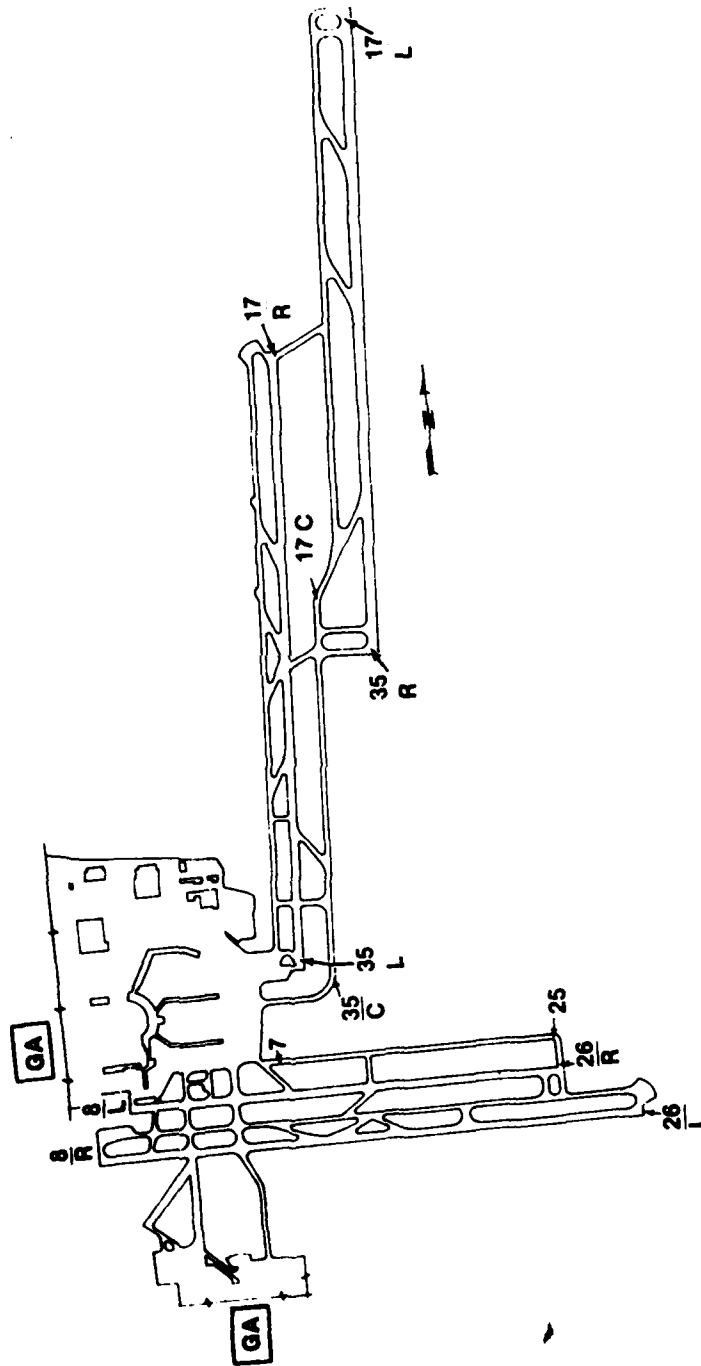

FIGURE 2-1
DENVER AIRPORT LAYOUT

The terminal at Denver has four concourses A, B, C, and D. Concourse A is used by commuter airlines. Concourse B is used by United Airlines and is the most active. Other airlines share concourses C and D.

General aviation operators are based at two locations on the airport, west of the terminal and south of the east-west runways.

2.2. New Runway And Taxiway Placement

The placement of the new parallel general aviation runway and taxiways is shown in Figure 2-2. The new runway, designated runway 18/36, is 4300 feet west of runway 17R/35L and 900 feet west of runway 17L/35R. This location allows simultaneous parallel ILS approaches to both the north and the south on either 17R/35L or 17L/35R. If the runway were just far enough west to permit independent operations to 17L/35R, the extended centerline of runway 18/36 would pass within 100 feet of the control tower restricting visibility of the flight path. Hence, it is desirable to place the new runway as far west as possible.

Runway 18/36 is bounded to the north by the common boundary of the airport, city, and county of Denver. Western and southern limits will be discussed in considering obstacle clearance requirements. The proposed runway is 4950 feet long and has an elevation of 5235 feet.

Two, parallel, fifty-foot wide taxiways, 4350 feet long, GA-2 and GA-3, connect taxiway L and runway 18/36. A parallel taxiway, GA, runs east of runway 18/36 and has two high-speed exits and aircraft holding areas at each end. Another short taxiway, GA-1, is added west of Z-1 and L-3 into the north terminal apron.

2.3 Potential Capacity Benefits

The need for additional runway capacity is shown in Figure 2-3. The 1985 demand was taken from the "Stapleton International Airport, Airport Improvement Delay Studies" (Reference 4). Figure 2-3 shows that the 1985 IFR capacity with the current runway configurations will be inadequate (arrivals on 35R and departures on 35L or arrivals on 17R and departures on 8R). The "IFR Capacity" line on Figure 2-3 represents the lower end of a range of IFR capacities that under certain circumstances may extend to 65 operations per hour, but which is still insufficient to meet the projected demand (Reference 3).

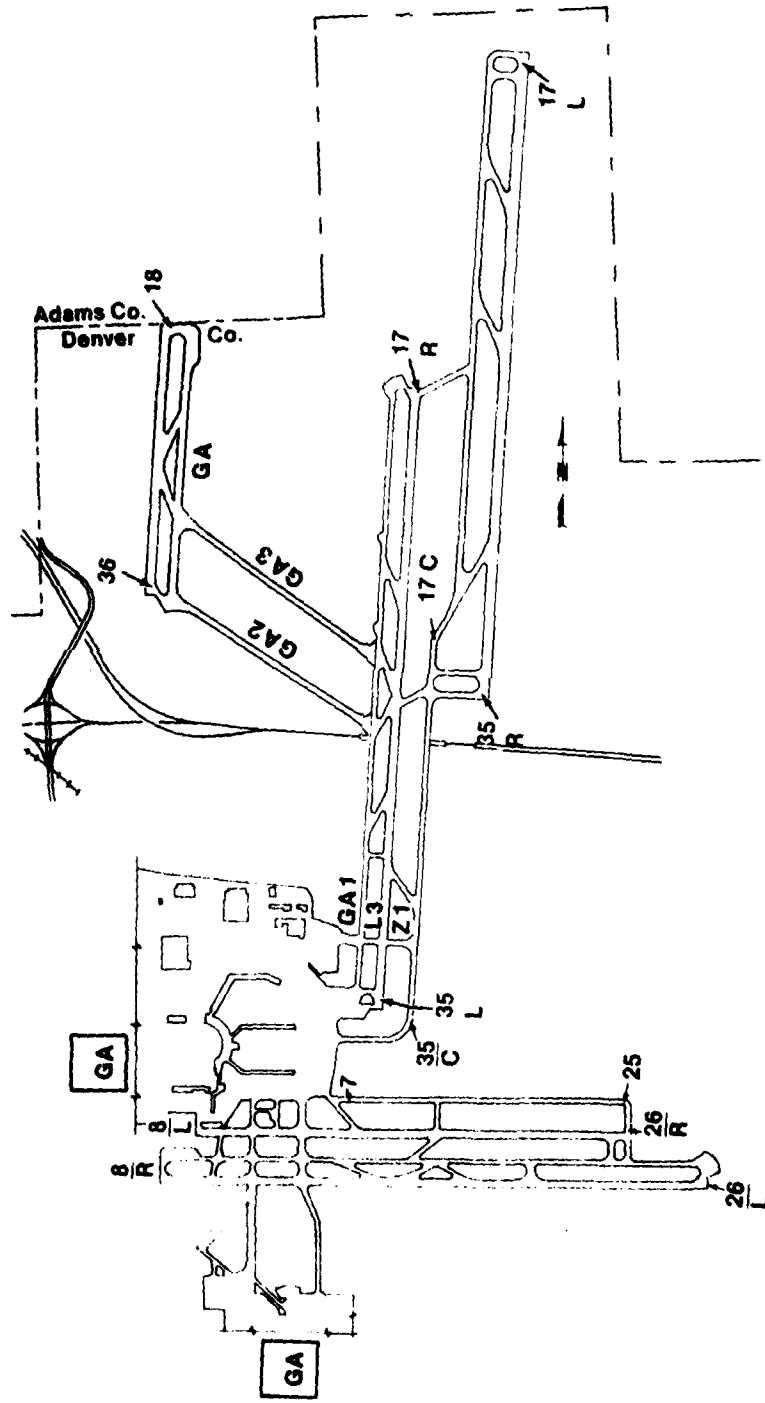
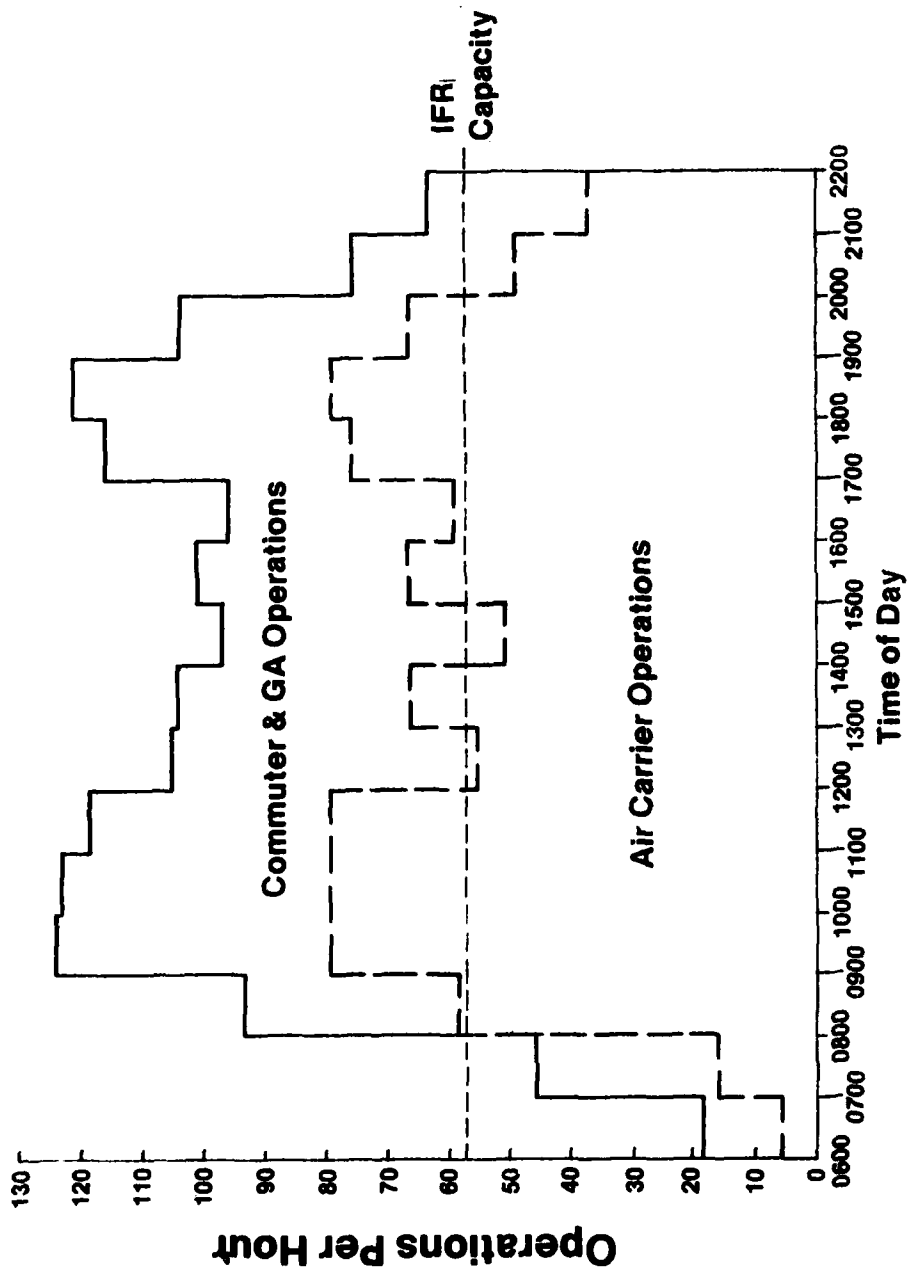

FIGURE 2-2
PROPOSED DENVER AIRPORT LAYOUT



Source: Reference 4, Table 4.

FIGURE 2-3
DENVER 1985 DEMAND VERSUS IFR CAPACITY

Table 2-1 gives the estimated IFR capacity analysis for the current and proposed configurations in 1985. Operations are equally divided between arrivals and departures. Heavy aircraft, e.g., DC-8 Series 60, DC-10, L-1011, B-747, C5A, constitute 11% of the traffic.

If the new runway is used for both arrivals and departures to the north, the capacity is increased by approximately 63%. The proposed configurations with landings to the south differ mainly in the degree of dependence of departures on arrivals. Aircraft approaching runway 17L or 18 and executing a missed approach would pass over runway 8R, the departure runway. Runway 8R is never fully independent of arrival runway 17L nor is it totally dependent. The degree of dependence depends on the type of aircraft departing on runway 8R. The departure is less dependent when fast aircraft depart runway 8R than when slow aircraft depart it.

TABLE 2-1
DENVER IFR CAPACITY IN OPERATIONS PER HOUR

TIME-FRAME	CONFIGURATION		1985 CAPACITY 50% ARRIVALS 11% HEAVY
	ARRIVALS	DEPARTURES	
PRESENT	35R	35L	56.1
PROPOSED	35R, 36	35L	72.3
PROPOSED	35R, 36*	35L, 36	91.7
PRESENT	17R(LOC (BACK CRS))	8R	61.0
PROPOSED	17L, 18	8R (IND.)	92.9
PROPOSED	17L, 18	8R (DEP.)	70.6

*PHASE ONE ANALYSIS OF THIS CONFIGURATION YIELDED DELAY BENEFITS OF \$2M-\$14M IN 1980 AND \$2M-\$25M IN 1990 DEPENDING ON THE LEVEL OF TRAFFIC (REFERENCE 1).

3. OBSTACLE CLEARANCE

The location of obstacles and placement of the runway and equipment is done from maps with scales no larger than 1 inch = 1000 feet, hence, accuracies are limited to + 30' in the plan view (Reference 5). The requirements laid down in "United States Standards For Terminal Instrument Procedures (TERPS)" are followed (Reference 6).

3.1 Physical Limits On Runway Placement

The approach end of runway 36 is limited by the Final Approach Area's obstacle clearance requirements and, specifically, the tower at Denver, Figure 3-1. The tower projects 256 feet above the runway elevation of 5235 feet. The tower limits the length of the runway to 4950 feet + 30 feet, with a 3° glide slope.

The western boundary of the GA runway is limited by the interference of trucks on I-270 with runway 36's clear zone.¹

Category II approaches could be made to runway 36. However, the tower would penetrate the Category II missed approach primary area prohibiting Category II approaches to runway 18.

3.2 Effects of Runway Length

With a field of elevation of 5235 feet, runway 18/36 has an equivalent sea-level length of approximately 4000 feet. This affects the runway's potential to reduce demand for the air carrier runway because some GA turbojet and turbofan aircraft are unable to land or takeoff in that distance.

¹ A visit to Denver, after completion of the analysis, showed that the city has constructed a municipal works department on the southeast corner of the intersection of East 56th Avenue and Quebec Street. This facility includes a fire training tower which would necessitate moving the proposed runway approximately 900 feet east. This does not affect the analysis or the projected capacity benefits, though runway 18/36 would no longer be independent of runway 17R/35L for arrivals. Operationally, the worst effect is that the approach path to runway 36 is now only 800 feet west of the tower.

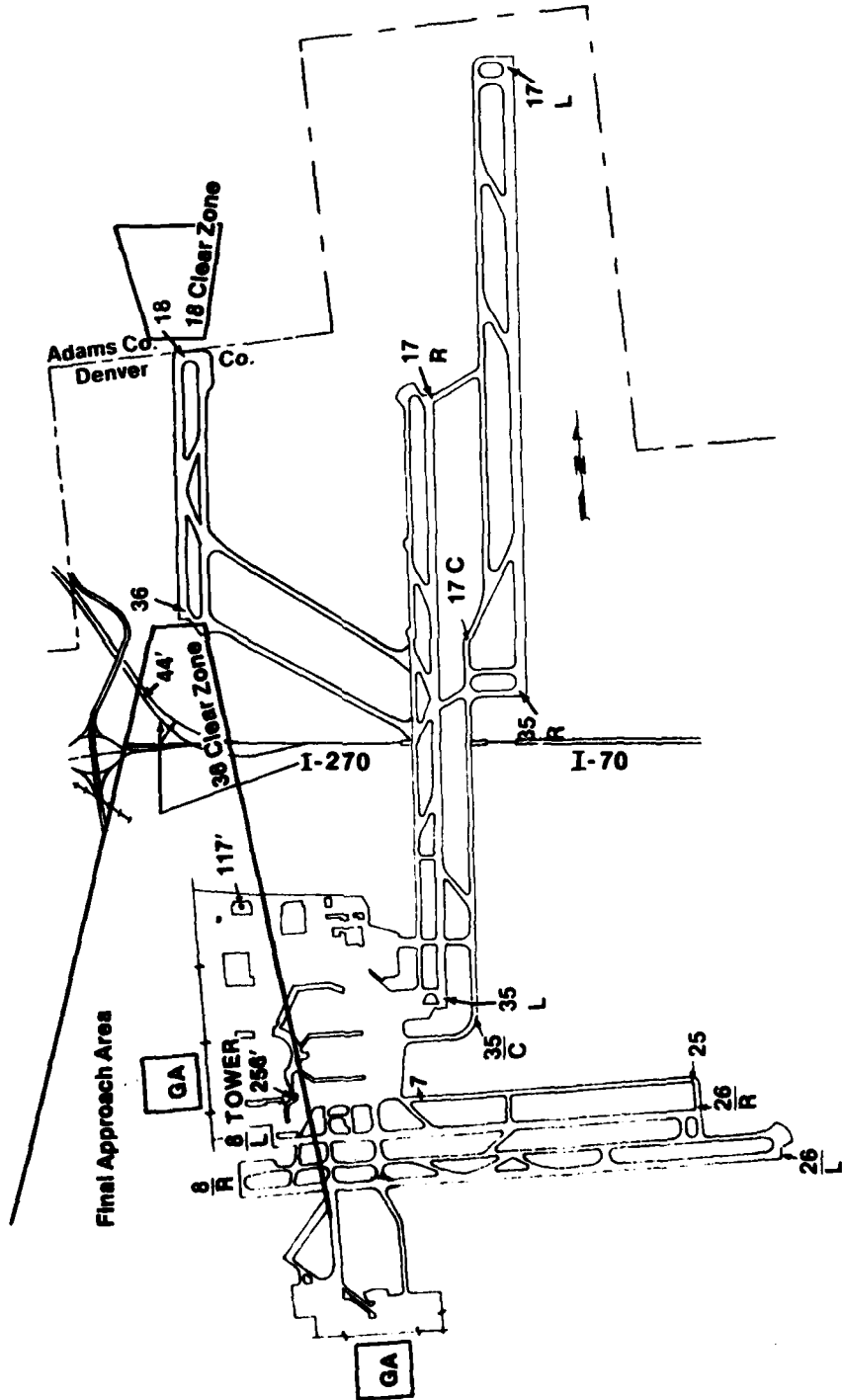

FIGURE 3-1
RUNWAY 18/36 OBSTACLE CLEARANCES

3.3 Potential Obstacle Clearance Problems

There are only two potential problems. First, the height of trucks on I-270 may be higher than 44 feet above the touchdown zone interfering with runway 36's clear zone. Second, planned construction around the GA runway may impact the location of the proposed runway. A detailed analysis is required to determine the exact placement of the proposed runway, but obstacle clearance does not appear to be a problem.

4. CRITICAL AREAS, NO PARKING AREAS, AND SITING REQUIREMENTS

Critical areas and no parking areas are zones in the vicinity of a radiating antenna that must be protected from uncontrolled movement and occupation by surface traffic to assure continuous integrity of the signal received by airborne aircraft. Siting requirements specify the regularity of the surrounding terrain. Irregular terrain may cause spurious navigation signals. Critical areas, no parking areas, and siting requirements are determined by the radiation characteristics and beam-widths of the azimuth and elevation signals (Reference 7). The critical and no parking areas for runway 36 are shown in Figure 4-1 and for runway 18 in Figure 4-2.

The antenna sites for runway 36 are affected by the highways to the south. I-70 rises from an underpass of air carrier runway 17R/35L to the east. It branches into I-70 and I-270. I-270 then passes over I-70 south of the proposed antenna sites.

Rather than compensating an ILS to allow for the highways, it may be cheaper and easier to install a MLS. A MLS has less demanding siting requirements and smaller critical area requirements than an ILS. Further analysis is needed to determine whether it is possible to site either an ILS or a MLS.

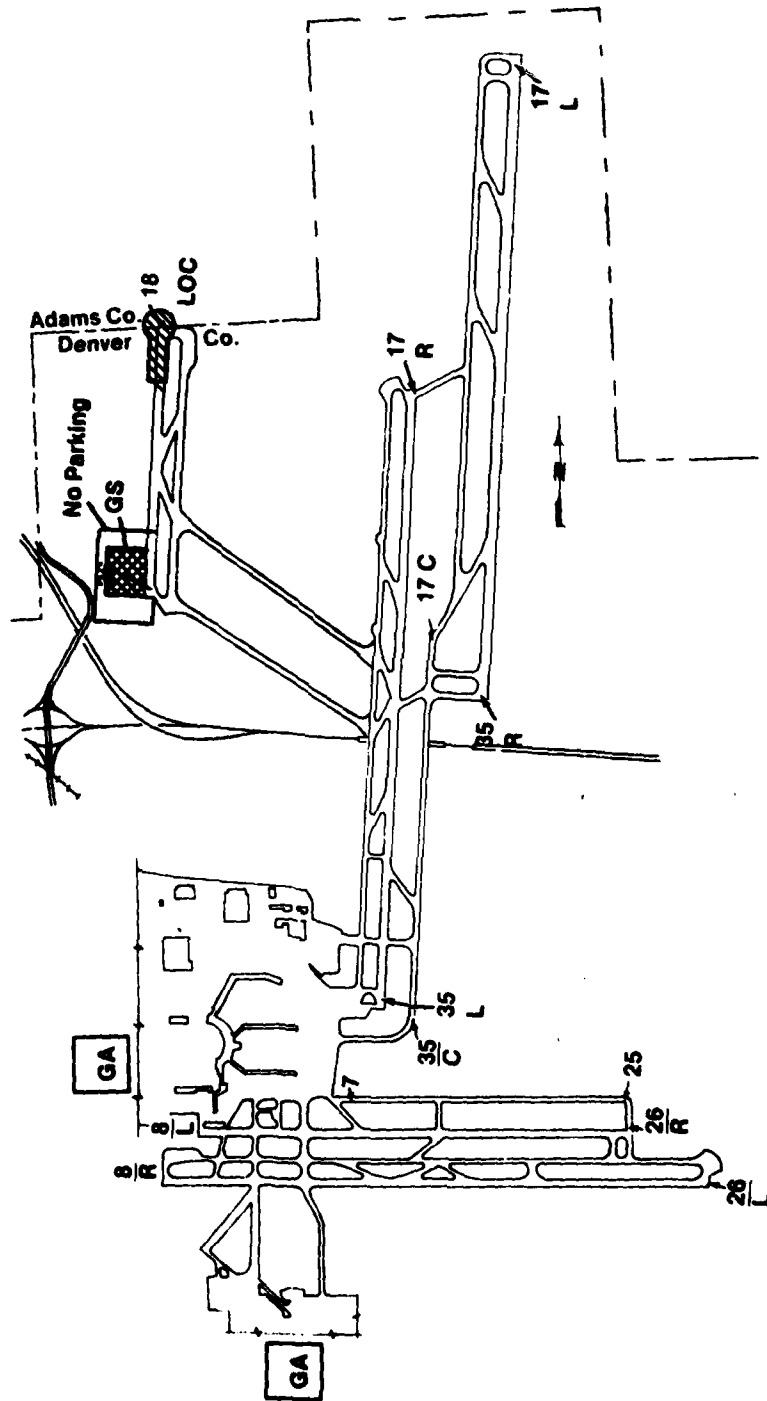

FIGURE 4-1
 RUNWAY 36 CRITICAL AND NO PARKING AREAS

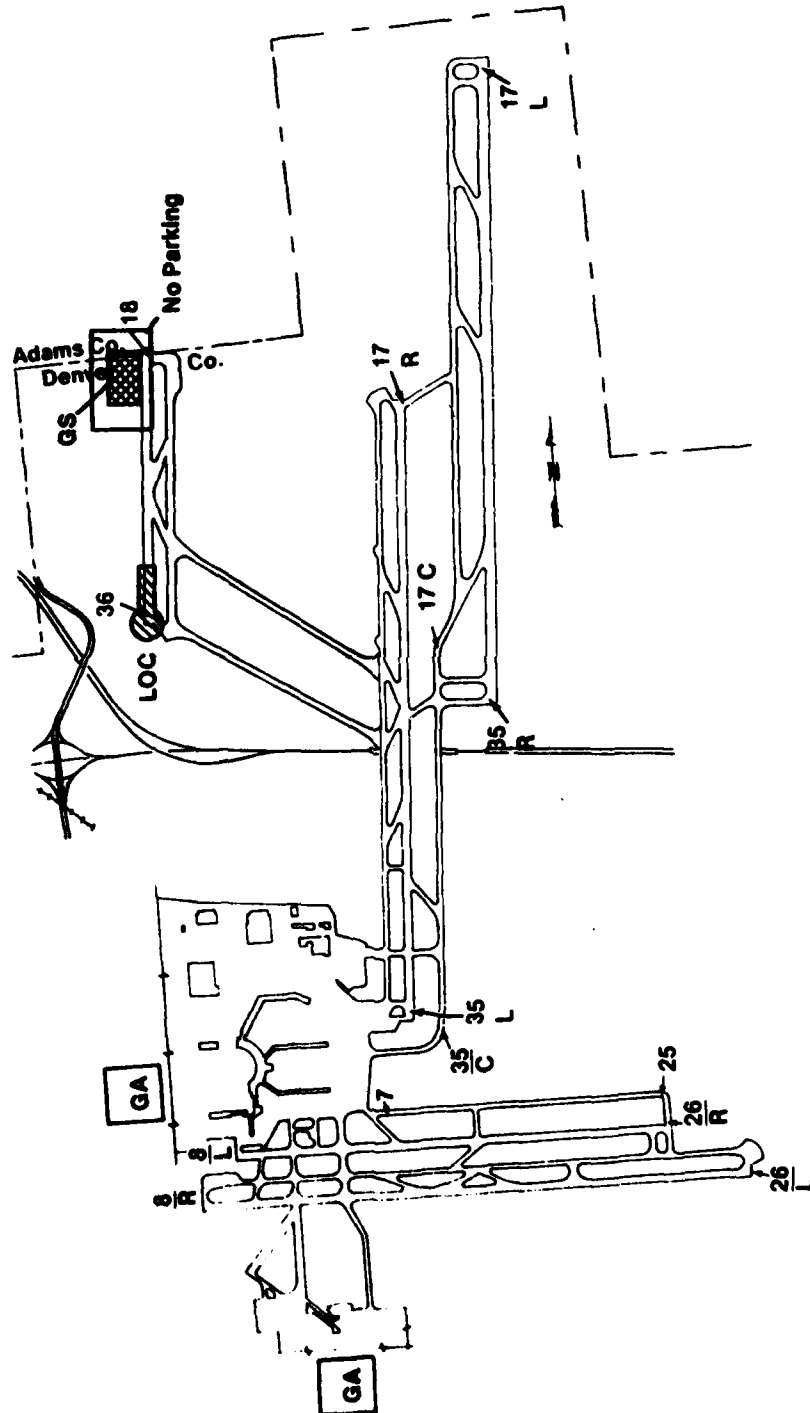

FIGURE 4-2
 RUNWAY 18 CRITICAL AND NO PARKING AREAS

5. AIRSPACE DESIGN

The Denver Air Route Traffic Control Center (ARTCC) controls IFR traffic arriving and departing the Denver area. Necessary holding is accomplished by the ARTCC at or before the arrival gates in accordance with traffic metering procedures. The ARTCC must ensure at least 5 nmi in-trail separation at the arrival gates. The ARTCC hands off traffic near the arrival gates to Denver Approach Control which is responsible for the terminal portion of the flight. The aircraft are handed off again to the final vector controllers in time to integrate any remaining confluent aircraft streams (Reference 8). With the proposed simultaneous parallel ILS approaches, the two final controllers, and the aircraft they control, would be monitored by a third controller.

The Denver terminal airspace is the area from the ground to 20,000 feet within a 35 nmi radius of Stapleton International Airport because within this area Denver Approach Control controls traffic. (It is much larger than the Terminal Control Area, TCA.) Speed control, as published on the applicable profile descent chart, and metering procedures are used in the terminal airspace as the primary method of maintaining in-trail separation and integrating traffic from different arrival gates. Generally, in-trail separation may be reduced by the approach controller to 3 nmi. If small and large aircraft are following heavy aircraft then the standard is 5 nmi. If a heavy aircraft is following another heavy aircraft then the standard is 4 nmi.

5.1 Design Criteria

Airspace design should ensure the ability to saturate the air carrier and general aviation runways. The aircraft are assumed to arrive randomly, by type, over the four arrival gates: Drake, Keann, Kiowa and Byson (Reference 9). The same arrival gates are applicable to all runway configurations. After passing these gates the aircraft must be separated by aircraft type, kept clear of non-arrival traffic, e.g., departing, missed approach, overflights, tower en route, blundering, VFR, and vectored to their respective runway approach paths.

Aircraft should proceed to the approach by the shortest possible route; flight away from the airport should be kept to a minimum. Depending on their assigned runway and arrival fix, some aircraft will have to fly a downwind leg, and/or a crosswind leg. These legs should be kept as short as possible and other errant vectors avoided.

In keeping with current practice, aircraft speed and path control are presumed for longitudinal separation and integration. The terminal area is stratified to facilitate coordination-free vectoring by approach and departure controllers. Current TERPS procedures are used (Reference 6).

5.2 Configuration Analysis

In IMC, under today's conditions, all aircraft are usually approaching one runway. Aircraft are vectored either to downwind and then base or directly to base on either side of the runway so that after being turned to the final approach course they have the appropriate spacing.

With current simultaneous parallel ILS approach procedures (not applicable to today's Denver environment), aircraft are routed to the runway on the same side of the airport as the aircraft's arrival fix, via an appropriate downwind, base, or both.

Changes in the terminal area approach paths are required when the approach streams are segregated into two aircraft types (air carrier and GA). For simultaneous parallel ILS approaches with type differentiation, it is necessary that aircraft be able to change from one side of the airport to the other to execute an approach to the appropriate runway. This is the major airspace design problem posed by a separate, short GA runway.

5.2.1 Landings And Departures To The North

Figure 5-1 illustrates an arrival procedure to runway 35R consistent with a recent profile descent chart and departures on runway 35L consistent with recent instrument departure procedures (Reference 8). The arrival aircraft are vectored from the arrival gates to the terminal fixes, Jasin, Flots, Wifes, or Troze, where they are turned onto downwind or base as appropriate. Those aircraft from Jasin or Flots on downwind are subsequently turned onto base inside the base of aircraft arriving from over Troze or Wifes. The four streams are then merged on final.

The departure procedure in Figure 5-1 is straightforward. Departures go out through stratified airspace and are protected by altitude from arrivals. The aircraft departing west immediately after take-off are required to meet strict climb requirements because of the Rocky Mountains. Aircraft

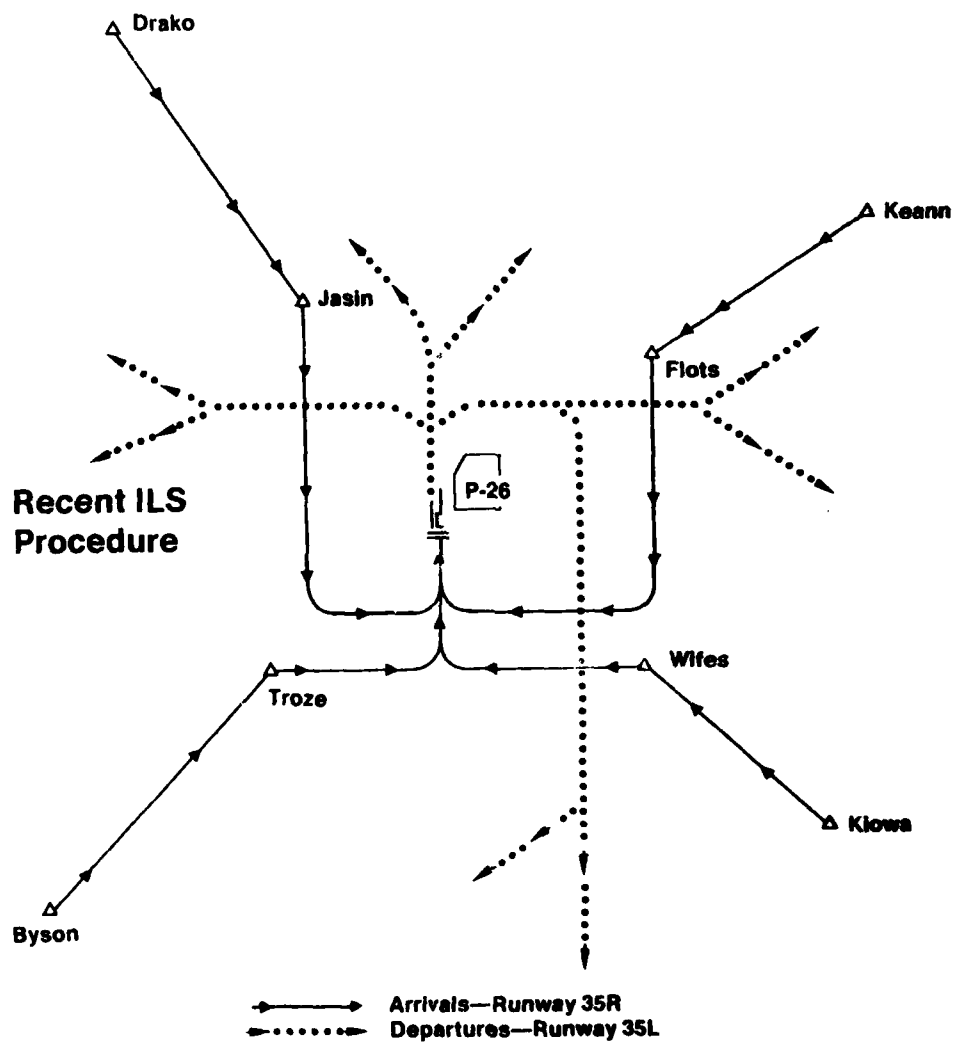

Consistent with Profile Descent Effective Feb. 23-79

FIGURE 5-1
 RECENT ILS PROCEDURE LANDING NORTH,
 TAKEOFF NORTH

immediately turning west are restricted to 10,000 feet until clear of arrivals from over Drako. Drako arrivals are restricted to 11,000 feet or above until clear of westward departures.

Figure 5-2 shows the proposed simultaneous parallel ILS procedure for arrivals and departures to the north. In this procedure, the aircraft are split into two streams, one for each runway, before turning base. The two aircraft streams, arriving from the east and from the west, are then merged on final. Conducting segregated, simultaneous parallel ILS approaches moves the base leg 3.15 nmi farther south because of the extra descent distance on the GS required by the higher aircraft.

The departures from runway 35L follow recent procedures except that the paths are extended. The departures from runway 36 are tunneled out in a stratified layer north or south and vectored on-course. Westbound flights maintaining a rate-of-climb of 335 feet per nautical mile or greater can proceed on-course. Separation between arrival paths and departure or missed approach paths was taken as 5 nmi.

5.2.2 Landings To The South And Departures To The East

Figure 5-3 illustrates an arrival procedure to the south to runway 17R consistent with a recent profile descent chart and departures on runway 8R consistent with recent instrument departure procedures (Reference 8).¹ The comments referring to recent procedures for arrivals and departures to the north are equally applicable here.

The proposed ILS procedures for arrivals on runway 18, GA traffic, and runway 17L, air carrier traffic, are essentially a north-south mirror image of landings to the north, Figure 5-4.

The departure procedure for runway 8R differs from the recent procedure in two ways. First, aircraft crossing the arrival streams from Kiowa must either reach 9000 feet before they are 3 nmi from downward arrivals, which requires a rate of climb of 585 feet per nautical mile, or remain at 7000 feet until 3

¹ Recent installation of an ILS on 17L have changed the procedures for landing to the south. The proposed procedures account for this modification.

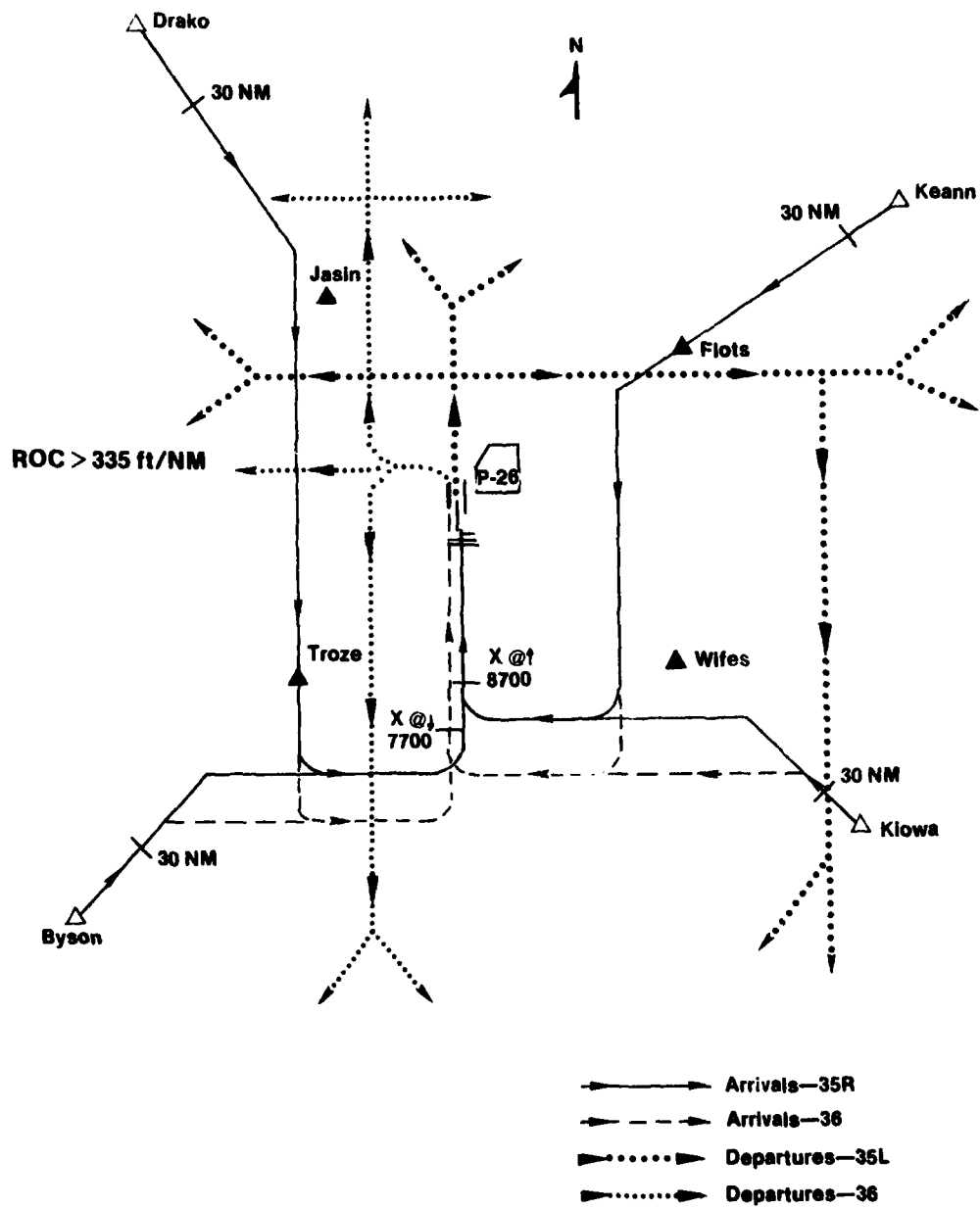
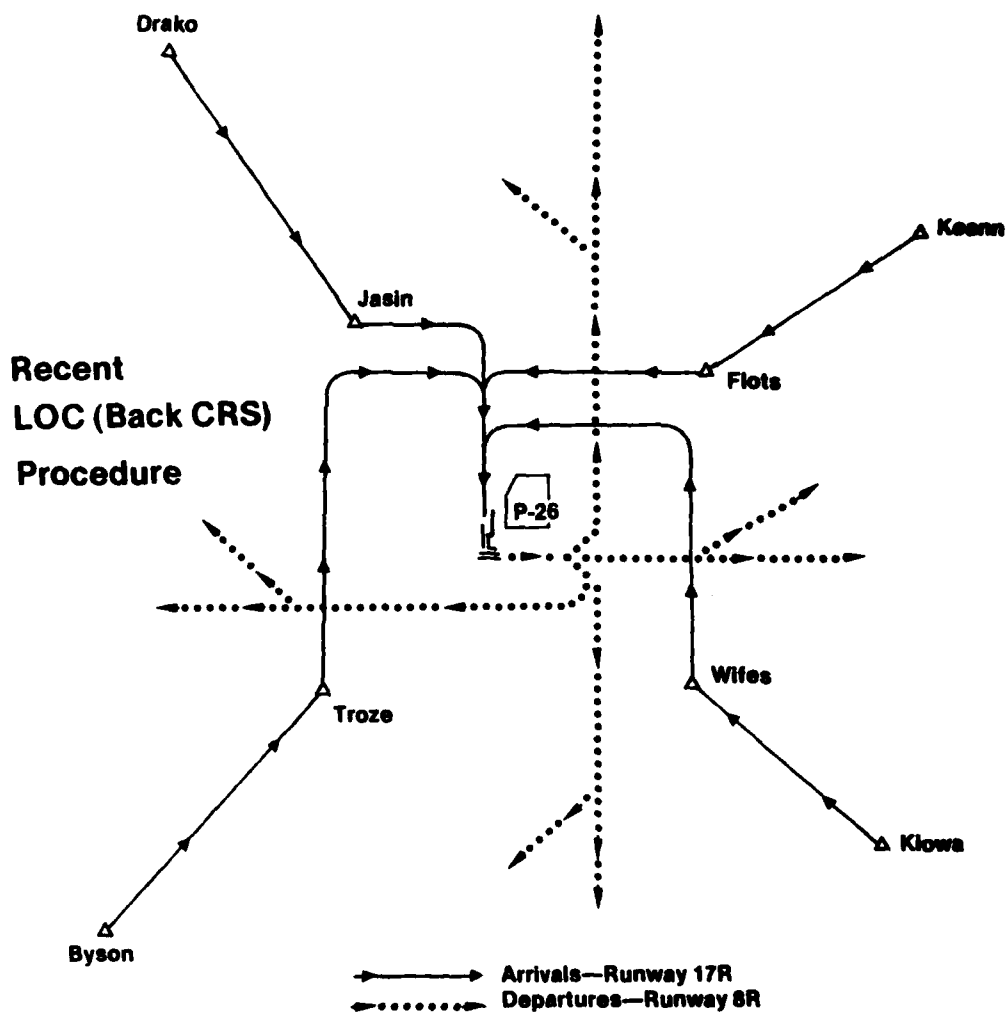

FIGURE 5-2
 PROPOSED ILS PROCEDURES LANDING NORTH,
 TAKEOFF NORTH



Consistent with Profile Descent Effective Feb. 23-79

**FIGURE 5-3
RECENT LOC (BACK CRS) PROCEDURE LANDING SOUTH,
TAKEOFF EAST**

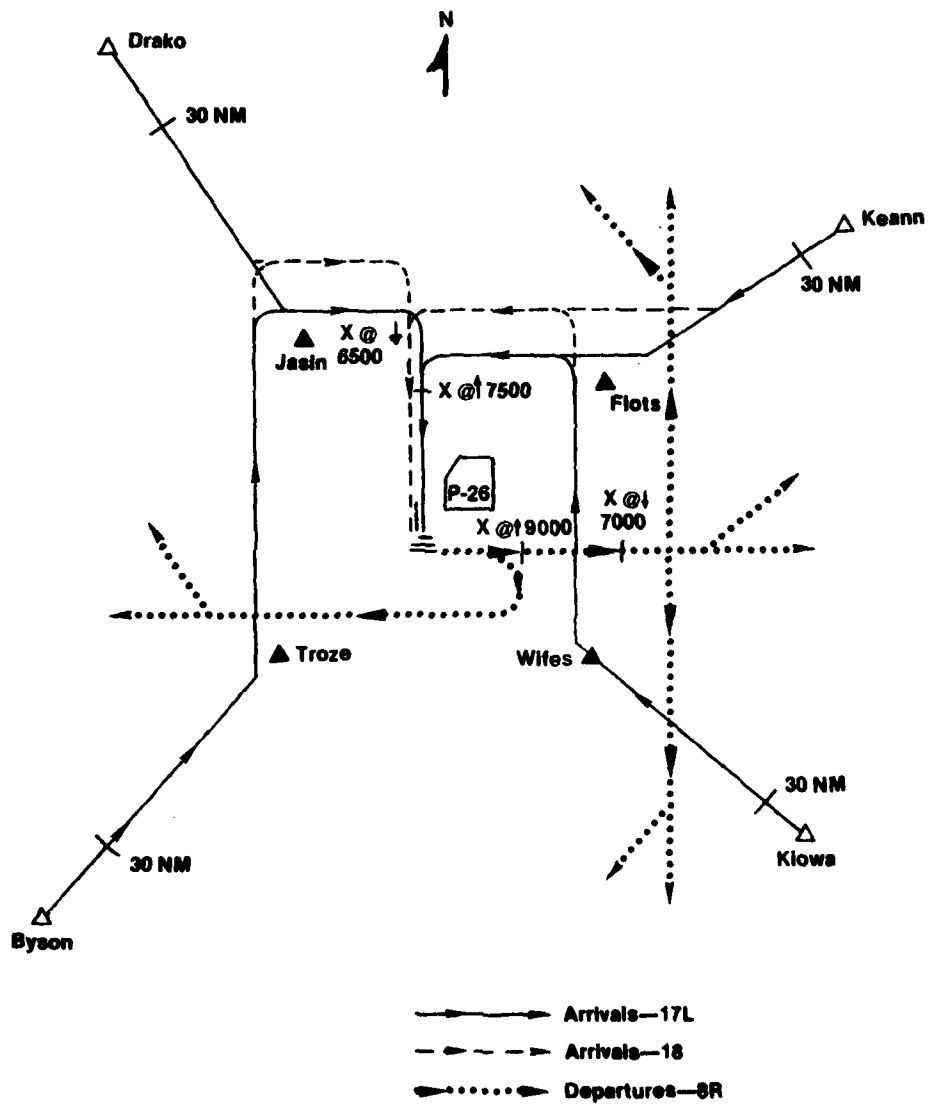

FIGURE 5-4
 PROPOSED ILS PROCEDURES LANDING SOUTH,
 TAKEOFF EAST

nmi past the downwind arrivals. This assumes that aircraft will be arriving over Kiowa at the minimum-enroute-altitude (MEA) of 8000 feet, that they will not be required to climb, and that other aircraft from Kiowa will be at or above 10,000 feet on downwind.

The turns to final are shown as curves but in reality they are as shown in Figure 5-5. The important point is that there is at least 1 nmi straight flight before a turn of less than 30° onto the final approach course. This is followed by at least 1 nmi of straight flight before glideslope interception.

It is important that the aircraft intercepting the final approach course at the lower altitude be turned onto the final approach course first. TERPS specifies that the aircraft must be separated by 1000 feet vertically or 3 nmi horizontally until both aircraft have intercepted and tracked the localizer for 1 nmi (be established on the localizer) (Reference 6). Figure 5-6 illustrates the advantage of having the lower aircraft turn onto the final approach course first. If the lower aircraft is turned-on first, the higher aircraft can start its descent as soon as it is established on the localizer. If the higher aircraft is turned-on first, it must travel 3 nmi beyond where the lower aircraft is established on the localizer before it can start its descent. Because of the higher altitude the higher aircraft must, in either case, descend for 3.15 nmi before the lower aircraft can start its descent on the GS (assuming equal final approach segments, 3° GS, and non-staggered GPIs).

5.3 Airspace Problems

5.3.1 Noise Impact

Runway 18/36 is located farther west than any of the existing runways and is, therefore, closer to Denver's city-center. The fan noise of turbofan aircraft on approach to runway 36 and the efflux noise of turbojets executing a missed approach on runway 18 may have a significant noise impact. Therefore, the specific mix of aircraft using the GA runway will be important.

5.3.2 Missed Approaches

The current procedure for missed approach when approaching runway 35R is to "Climb to 9000' via outbound DEN VOR R-352 to THORNTON NDB/DEN 5.6 DME and hold."

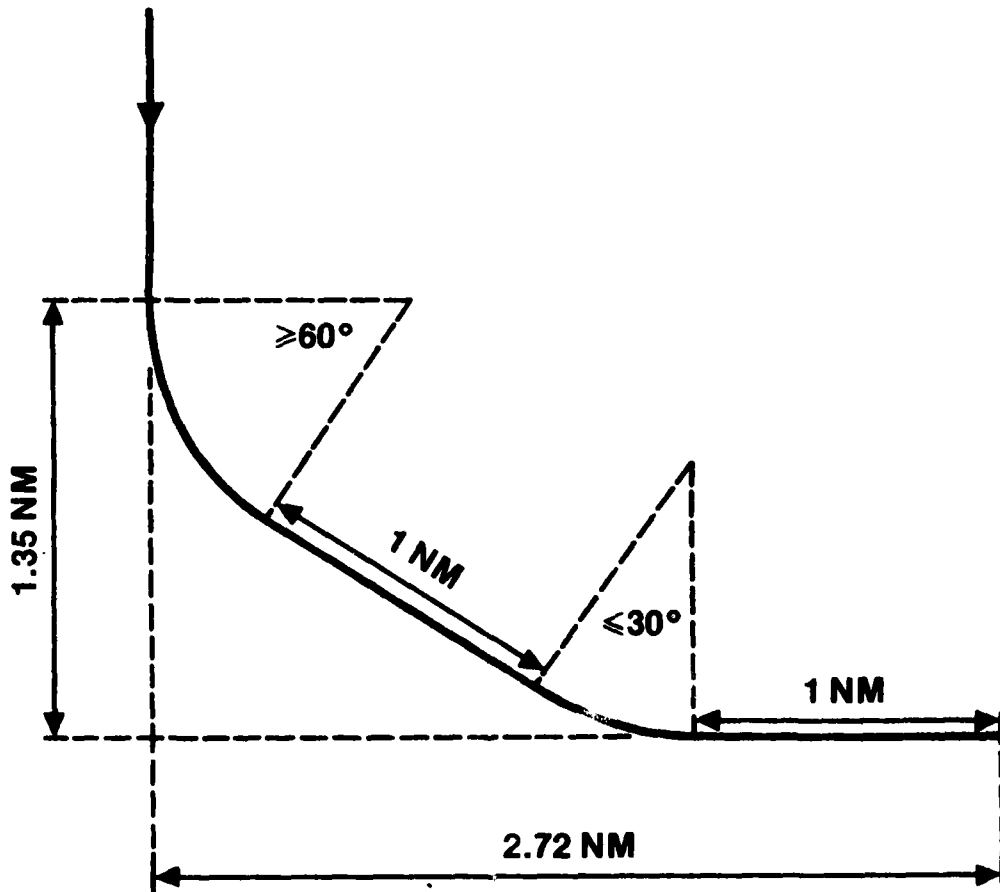
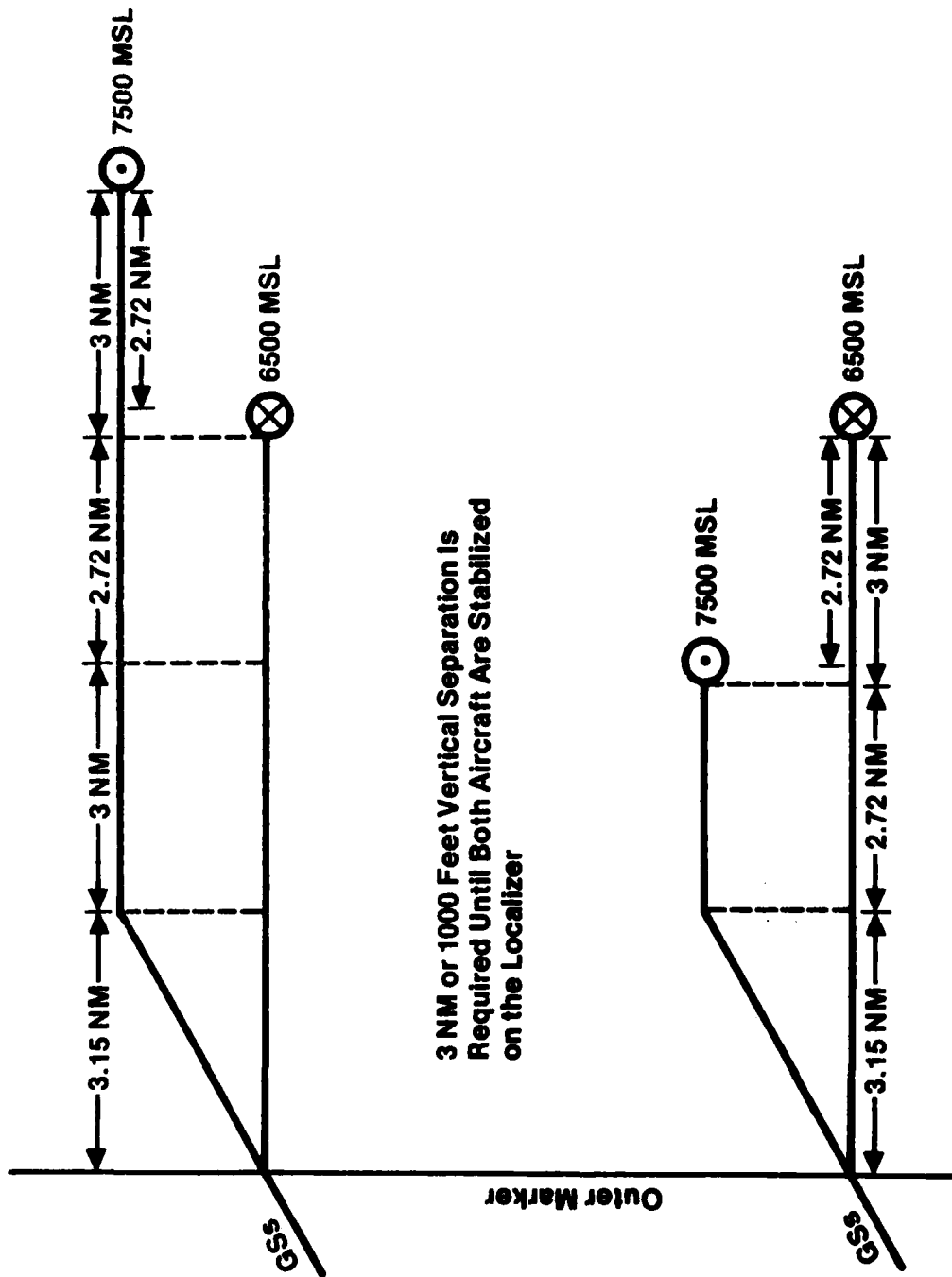

FIGURE 5-5
PLAN VIEW OF RADAR TURN-ON TO ILS (160 KTS)



3 NM or 1000 Feet Vertical Separation Is Required Until Both Aircraft Are Stabilized on the Localizer

FIGURE 5-6
TURN-ON PRIORITY STRATEGY

During simultaneous parallel ILS approaches it is proposed to retain this missed approach procedure for runway 35R and to turn missed approaches to runway 36 to the west. With this procedure, aircraft will not pass over the Rocky Mountain Arsenal (P-26) which is located approximately 1.5 nmi east of the departure end of runway 35R. This differs from the current practice at other airports where during parallel missed approaches both aircraft are turned away from the inbound course and each other. But it is consistent with TERPS (Reference 6) which says "The missed approach shall specify a straight ahead climb to at least 400 feet above the touchdown zone; then, a divergence of at least 45 degrees shall be provided between the two missed approach headings as soon as practical after reaching 400 feet and until the missed approach and/or limitation fixes are reached. A missed approach shall be established for each of the simultaneous systems and shall be the same as the missed approach for the single ILS procedure." If the missed approach to runway 35R remains the same, it is consistent with TERPS without routing missed approaches over the Rocky Mountain Arsenal. The published missed approach procedure for runway 36 would read: "Climb straight ahead to 5635' turn left to intercept DEN VOR R-240 outbound, continue climb to 7000', within 12 nmi reverse course to DEN VOR R-240 inbound, and hold, right turns."

In the event of a blunder on runway 36, an aircraft on runway 35R may still have to deviate through area P-26. If aircraft approaching 35R were required to have a rate-of-climb of 385' per nautical mile, P-26 could still be avoided, Figure 5-7. This criterion is easily met by today's air carrier aircraft in normal operations.

Currently the missed approach procedure for landings to the south on runway 17R is "Climb to 9000' on SOUTH course of ISPO LOC to ENGLE INT." It is proposed to retain this for runway 17L. There is a conflict between aircraft approaching runway 17L and departures on runway 8R. Horizontal separation is required because vertical separation cannot be assured. To guarantee 3 nmi separation, even with the straight-out missed approach, it is necessary to hold departures when an arrival is close to touchdown. Light aircraft such as Cessna Skyhawks and Skylanes and Piper Cherokees and Arrows cannot be released when an air carrier aircraft is within two minutes of touchdown. However, aircraft such as air carrier jets, Learjets, Falcon 10s or military fighters can be released when the air carrier aircraft is 20 or more seconds from touchdown. The missed approach procedure for runway 18 would read: "Climb to 5635' and turn right to intercept DEN VOR R-240 outbound, climb to 7000', within 12 nmi reverse course to DEN VOR R-240 inbound, and hold, right turns."

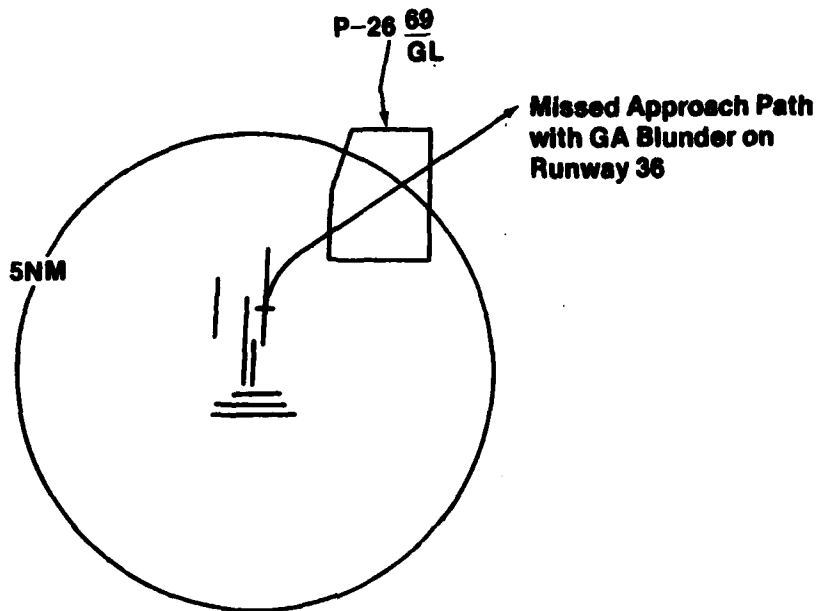

Possible Solution—Require Rate-of-Climb Greater than 385' /NM on Air Carrier Runway

**FIGURE 5-7
MISSED APPROACHES OVER P-26**

A Microwave Landing System could provide precision missed approach guidance for runway 18/36 perhaps improving the acceptability of the proposed deviation from current practice.

5.3.3 Terminal Control Area

It will be necessary with the proposed airspace design to expand the current TCA, Figure 5-8, from a radius of 20 nmi to 28 nmi to accommodate the expanded terminal airspace maneuvering. The floor of the new TCA will need to be 6500 feet at least 10 nmi southward along the approaches to runways 35R and 36, 6500 feet at least 10 nmi northward along the approaches to runways 17L and 18, and 7000 feet at least 13 nmi eastward along the departure path of runway 8R. These extensions will not be required if the vectoring of aircraft outside the TCA to final approach courses and during climb restriction is acceptable.

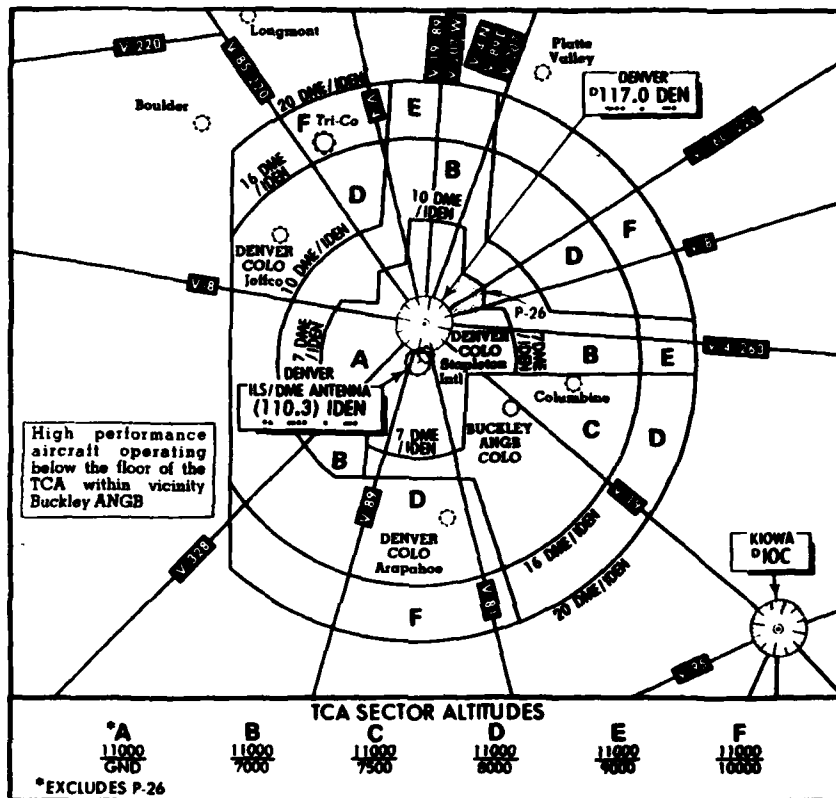

Copyright 1978, Jeppesen Sanderson, Inc., Denver, Colo., U.S.A.

Reproduced with Permission
Not to Be Used for Air Navigation

**FIGURE 5-8
CURRENT DENVER TERMINAL CONTROL AREA**

6. GROUNDSIDE DESIGN

Once the aircraft has landed and exited the active runway it is controlled by ground control both for taxiing to parking and for taxiing from parking to the runway for take-off.

6.1 Design Criteria For Taxiways And The Terminal Apron

It is as necessary on the groundside as the airside that traffic flow with as little conflict as possible. In placing the new taxiways out to runway 18/36, maximum access to the general aviation areas is required commensurate with the policy of the City of Denver that no new taxiways be built over highways. Twin, fifty-foot wide taxiways are required to allow runway use if one taxiway is blocked and to allow immediate access to the runway in event of an accident.

6.2 Configuration Analysis

6.2.1 Landings And Departures To The North

At present, runway 35R is used for arrivals and runway 35L is used for departures. Arrivals exit the runway to the left as shown in Figure 6-1 and taxi south on taxiway Z or cross runway 35L via taxiways Z6 and L9 then south on taxiway L to the terminal. Departures on runway 35L proceed directly to the queue area adjacent to the runway.

The proposed taxi pattern, Figure 6-2, has the advantage of allowing runway 35R arrivals to enter the north terminal apron for the north side of concourse D or the GA area west of the terminal by a new taxiway, GA1, extended west from taxiways Z1 and L3. This frees the congestion around the east end of concourse D. Aircraft arriving on runway 36 would be encouraged to make high-speed turnoffs by the location of the high speed taxiway GA4 relative to taxiway GA3. After joining taxiway L, aircraft would taxi south to taxiway GA1 where they would cross onto the north apron for the GA area west of the terminal. Those going to the south side of the field or to concourse A (the commuter terminal) would turn onto the apron west of taxiway L2.

If departures are also going to be conducted on runway 36, there will be a two-way flow of traffic on taxiway L between taxiways L2 or GA1 and taxiway L6. This undesirable situation can be avoided by building a GA overpass to cross the highway north of the concourses (Section 6.3).

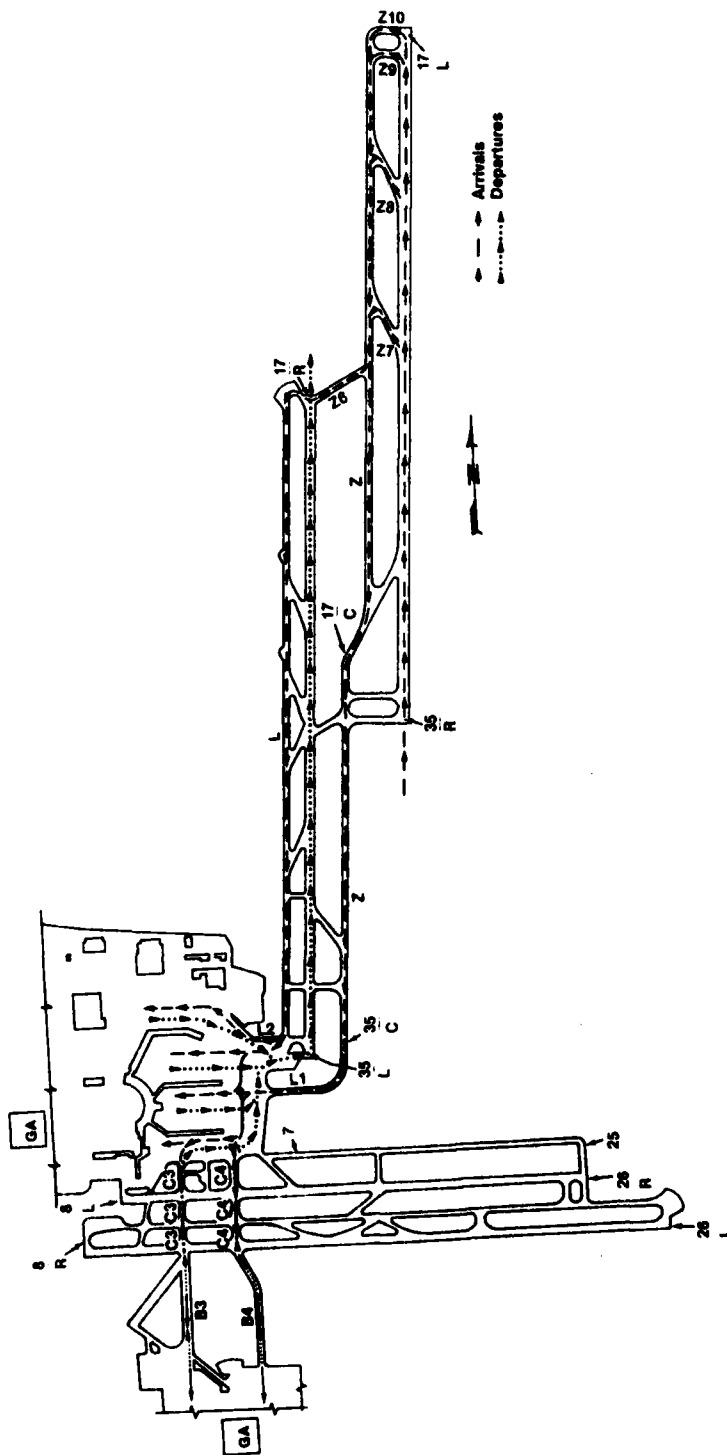

FIGURE 6-1
CURRENT TAXI PATTERNS LANDING NORTH.
TAKEOFF NORTH

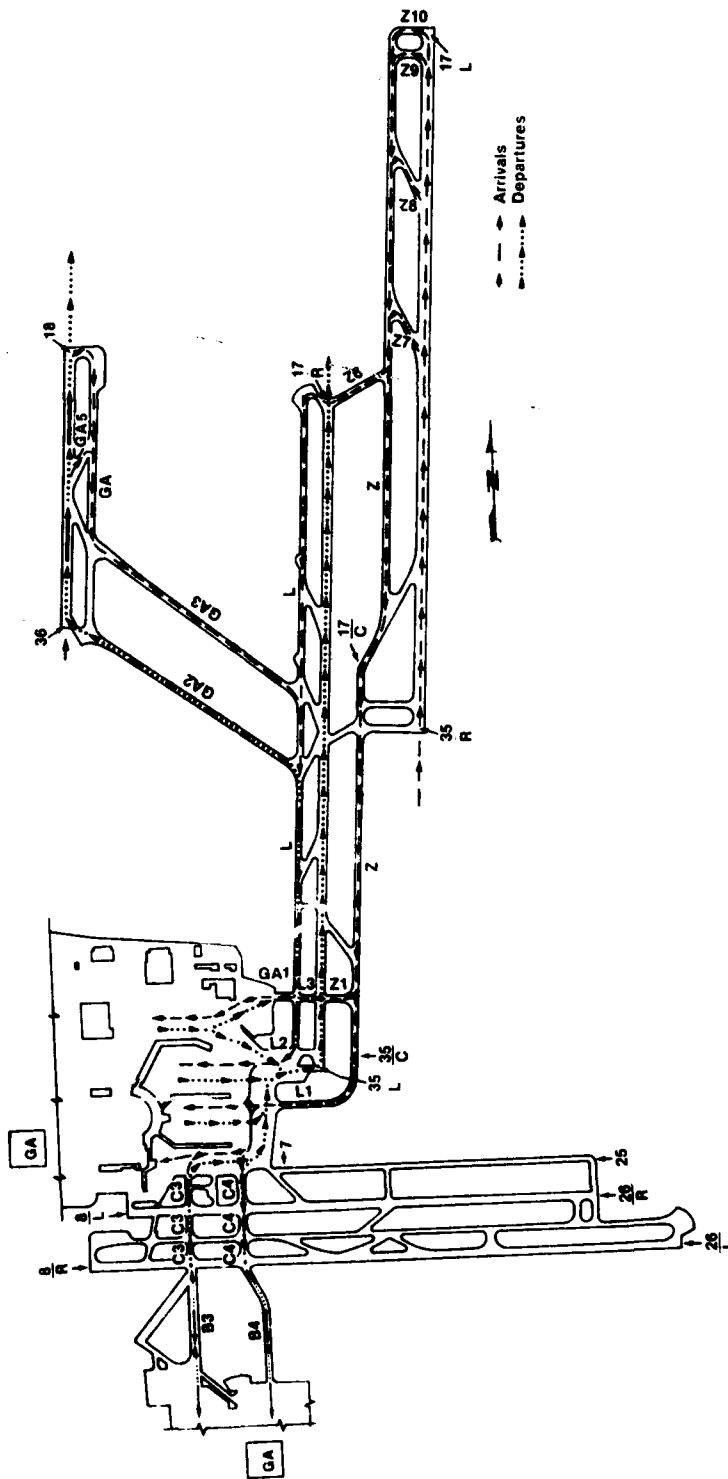

FIGURE 6-2
 PROPOSED TAXI PATTERNS LANDING NORTH,
 TAKEOFF NORTH

6.2.2 Landings To The South And Departures To The East

Currently runway 17R is used for arrivals. Arrivals exit to the right taking taxiway L to the terminal, Figure 6-3. Arrivals going to the south ramp must obtain clearance prior to crossing runway 8R via taxiway C3 or C4. Aircraft departing on runway 8R taxi via taxiways C2, C3, or C4 and queue on taxiways C or C1.

The proposed taxi pattern would move air carrier arrivals to runway 17L. Arrivals would exit to the right and taxi along Z to the terminal. Aircraft going to the north side of concourse D or the GA area west of the terminal would exit to the right and taxi along taxiway Z to taxiway Z1 crossing taxiways Z1, L3, and GA1 (Figure 6-4).

GA arrivals on runway 18 could use either taxiways GA2 or GA3 to taxiway L and then taxi south on taxiway L. Those going to the GA area west of the terminal would exit on GA1 while those going to concourse A or the south ramp would turn onto the apron opposite taxiway L2.

Taxiing for departure on runways 8R/8L is unchanged.

6.3 Groundside Problems

There is currently a bottleneck along the south side of concourse B when aircraft are being pushed back. Presumably, this affects commuter aircraft going to concourse A the most. This effect will get progressively worse as the average size of aircraft along concourse B (United Airlines) and those bound for concourse A (commuters) get larger. It is not feasible to extend the terminal apron farther south.

Bottlenecks could develop along the east side of the terminal as traffic increases even with the improved access to concourse D via taxiway GA1. This effect would be aggravated by any concourse extensions. The apron could not be extended to the east without infringing on runway 35L's critical area and/or clear zone.

If runway 36 is used for departures, the two-way flow of traffic on taxiway L between taxiways L2 or GA1 and taxiway L6 will significantly impede traffic in both directions. Two-way flow on taxiways C3 and C4 also hinders traffic movement, particularly when runway 8R is the departure runway. A solution to both these problems is to move as many GA

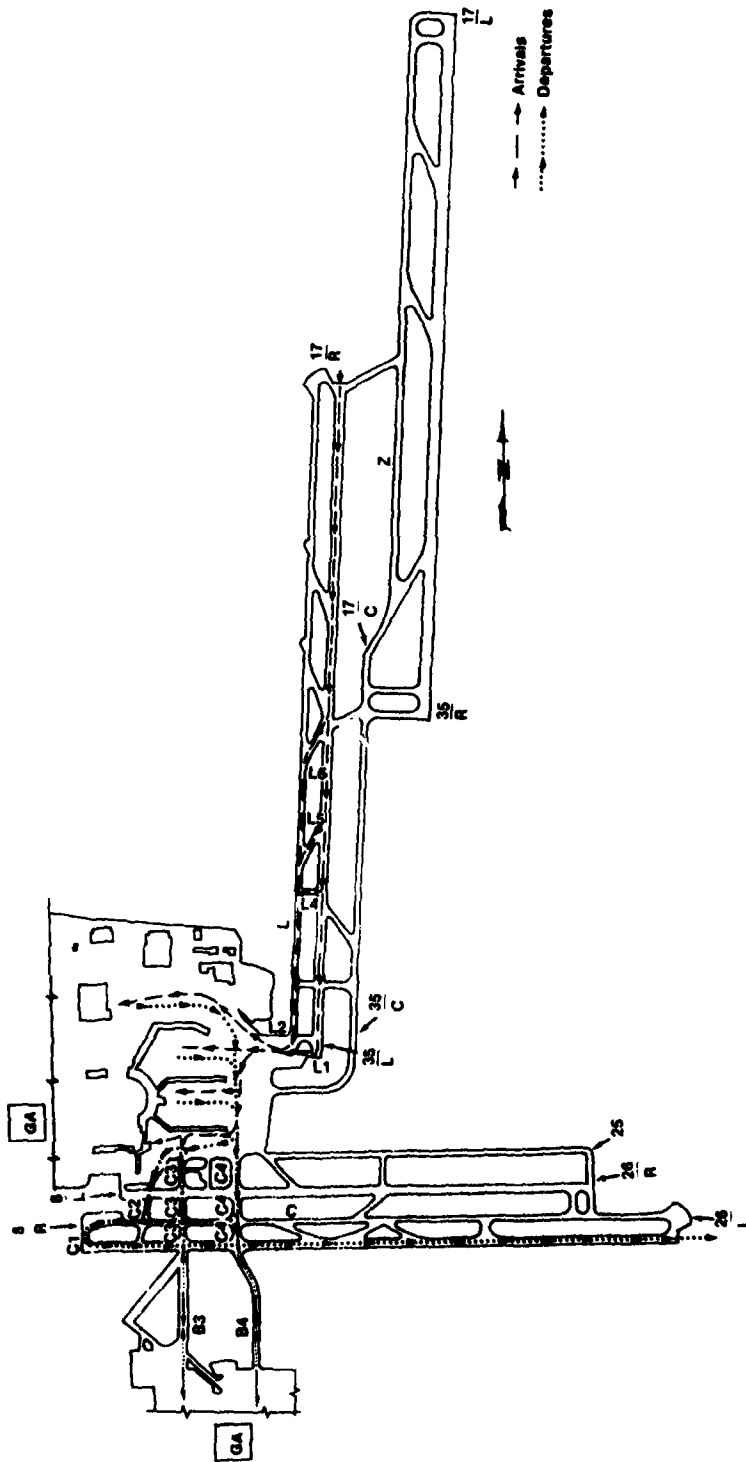

FIGURE 6-3
CURRENT TAXI PATTERNS LANDING SOUTH,
TAKEOFF EAST

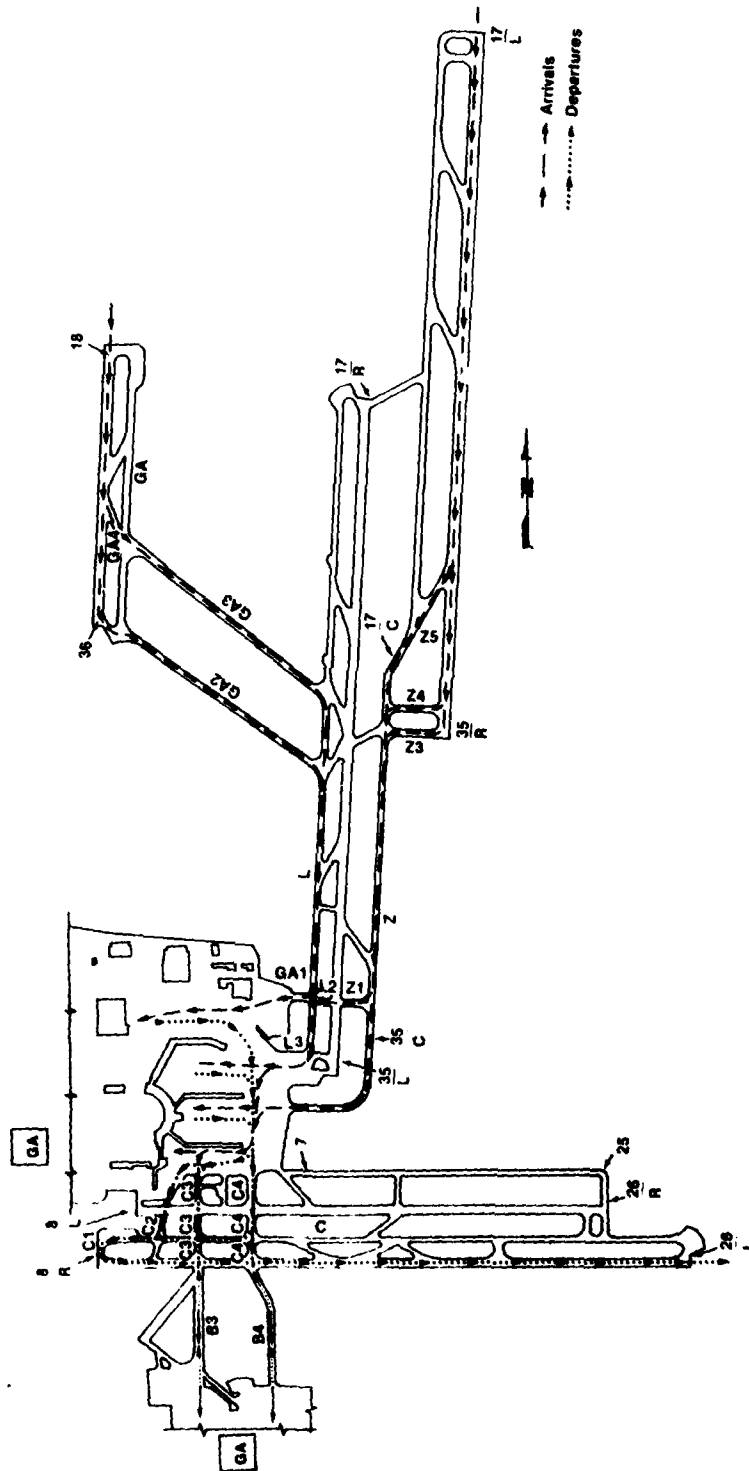

FIGURE 6-4
 PROPOSED TAXI PATTERNS, LANDING SOUTH,
 TAKEOFF EAST

operators as possible from the south side of the terminal to areas adjacent to runway 18/36. A second, partial solution, which would compliment the first, is to build an overpass across I-70 directly to the north edge of the terminal apron. While this violates a design criterion, the size and strength of an overpass required for GA traffic would be less of an engineering and financial undertaking than the current overpasses for air carrier aircraft. Solutions like these will be necessary, with increased airside capacity, to prevent groundside congestion.

7. CONCLUSIONS AND RECOMMENDATIONS

The analysis indicates that the proposed commuter/general aviation runway is feasible. It offers benefits in terms of increased capacity and reduced delay to Denver's Stapleton International Airport. These projected benefits may be reduced if fewer general aviation aircraft than forecast can use the new runway because of its short length.

The noise generated by traffic approaching to the north or executing a missed approach either to the north or to the south may be an important issue, but is beyond the scope of this study.

A Microwave Landing System may be required for runway 36 because of uneven terrain. This would require new equipment in general aviation aircraft, the segment of the industry that traditionally equips last.

It is important that excess airside demand not be translated into excess groundside demand. An additional access to the terminal apron should be built west of taxiways Z-1 and L-3. It is further recommended that as many GA operations as practical be moved adjacent to the new runway and that an overpass across I-70 for GA aircraft be considered.

Other issues such as land availability for navigational aids, critical areas, or clear zones, and the expansion of the Terminal Control Area appear not to pose any insurmountable problems.

APPENDIX A

INSTALLATION COST ESTIMATES

This appendix provides an order of magnitude estimate of the cost of installing the proposed GA runway. Actual costs based on a site survey may vary. The installation costs are in 1980 dollars. The following equipment will be required. For runways 18 and 36, complete Instrument Landing Systems at \$470,000 each and medium intensity approach light systems at \$190,000 each will be needed. Approximately 35,000 feet of taxiway lights and 10,000 feet of runway lights will be needed, \$210,000. Land will be required for one approach light system and one middle marker for runway 18, and two outer markers for runways 18 and 36, \$110,000. This totals \$1.6 million dollars for equipment and land.

The excavating and paving is estimated at \$43 per square yard for nine-inch thick concrete. There are approximately 195,000 square yards to be paved. Therefore, excavating and paving costs will be \$8.4 million. Added to the cost of equipment and land, this gives an estimated cost of \$10.0 million for the installation.

Denver Approach Control would require another final approach controller and another radar presentation for two monitoring controllers. The approach control room at Denver does not have the space required for an additional radar scope and three additional personnel; it would require expansion. The monitoring controllers would require a frequency override capability on the final approach controllers and their frequencies.

APPENDIX B

REFERENCES

1. Amodeo, F. A. and Koenig, S. E., "Potential Benefits of the Use of Separate Short Runways at Major Airports," The MITRE Corporation, Metrek Division, MTR-79W00374, September 1979.
2. Michael, R. S., "Stapleton International Airport - Managers Bulletin, 76-5, Aircraft Noise Abatement and Preferential Runway Use," City and County of Denver Department of Public Works, October 1, 1976.
3. "Stapleton International Airport, Airport Improvement Task Force, Delay Study, Final Report," November 1979.
4. "Stapleton International Airport, Airport Improvement Task Force Delay Studies," Data Package No. 5, Peat, Marwick, Mitchell & Co., September 1978.
5. National Ocean Survey "Airport Obstruction Chart Stapleton International Airport, Denver, Colorado (OC114)," U. S. Department of Commerce, June 1977.
6. Federal Aviation Administration, "United States Standards for Terminal Instrument Procedures (TERPS)," Handbook 8260.3B, Third Edition, July 1976.
7. Spingola, A. J., "Ground/Airborne Scenarios Stapleton International Airports," U. S. Department of Transportation, Report No. FAA-NA-75-191-1, June 1978.
8. "Jeppesen Instrument Procedures Charts for Stapleton International Airport," Times - Mirror, Inc., Current as of September 1979.