

12

LEVEL II

AD-E3009109

AD A089190

DNA 4799F

EARLY DEVELOPMENT OF TNF S² TEST CAPABILITY

The BDM Corporation
P.O. Box 9274
Albuquerque, New Mexico 87119

26 December 1978

Final Report for Period April 1978—November 1978

CONTRACT No. DNA 001-78-C-0245

APPROVED FOR PUBLIC RELEASE;
DISTRIBUTION UNLIMITED.

THIS WORK SPONSORED BY THE DEFENSE NUCLEAR AGENCY
UNDER RDT&E RMSS CODE B390078464 V99QAXNL12261 H2590D.

FILE COPY

Prepared for
Director
DEFENSE NUCLEAR AGENCY
Washington, D. C. 20305

DTIC
ELECTE
SEP 16 1980
S D
B

80 8 22 093

Destroy this report when it is no longer
needed. Do not return to sender.

PLEASE NOTIFY THE DEFENSE NUCLEAR AGENCY,
ATTN: STTI, WASHINGTON, D.C. 20305, IF
YOUR ADDRESS IS INCORRECT, IF YOU WISH TO
BE DELETED FROM THE DISTRIBUTION LIST, OR
IF THE ADDRESSEE IS NO LONGER EMPLOYED BY
YOUR ORGANIZATION.



12/143

18/DNA, SBIE

UNCLASSIFIED

SECURITY CLASSIFICATION OF THIS PAGE (When Data Entered)

REPORT DOCUMENTATION PAGE		READ INSTRUCTIONS BEFORE COMPLETING FORM
1. REPORT NUMBER DNA 4799F	2. GOVT ACCESSION NO. AD-A089190	3. RECIPIENT'S CATALOG NUMBER 9
4. TITLE (and Subtitle) EARLY DEVELOPMENT OF TNF S ² TEST CAPABILITY	5. TYPE OF REPORT & PERIOD COVERED Final Report, Final Apr 78 - Nov 78	
7. AUTHOR(s) G. L. Brown R. V. Hovland	K. S. Redus F. Trujillo	6. PERFORMING ORG. REPORT NUMBER BDM/TAC-78-545-TR
9. PERFORMING ORGANIZATION NAME AND ADDRESS The BDM Corporation P.O. Box 9274 Albuquerque, New Mexico 87119	10. PROGRAM ELEMENT, PROJECT, TASK AREA & WORK UNIT NUMBERS Subtask V99QAXNL122-61	8. CONTRACT OR GRANT NUMBER(s) DNA 001-78-C-0245
11. CONTROLLING OFFICE NAME AND ADDRESS Director Defense Nuclear Agency Washington, D.C. 20305	12. REPORT DATE 26 December 1978	13. NUMBER OF PAGES 142
14. MONITORING AGENCY NAME & ADDRESS (if different from Controlling Office) 4799F AD-E300 910	15. SECURITY CLASS (of this report) UNCLASSIFIED	16. DECLASSIFICATION/DOWNGRADING SCHEDULE 17) L122
16. DISTRIBUTION STATEMENT (of this Report) Approved for public release; distribution unlimited.		
17. DISTRIBUTION STATEMENT (of the abstract entered in Block 20, if different from Report)		
18. SUPPLEMENTARY NOTES This work sponsored by the Defense Nuclear Agency under RDT&E RMSS Code B390078464 V99QAXNL12261 H2590D.		
19. KEY WORDS (Continue on reverse side if necessary and identify by block number) Test and Evaluation operational Test C ³ I Weapons Delivery Systems Data Management Test Ranges Theater Nuclear Force Nuclear Weapons Test Facilities Data Management Plan Data Control Analysis Methods		
20. ABSTRACT (Continue on reverse side if necessary and identify by block number) This report addresses results derived in the early development of an operational test capability to support the Theater Nuclear Force Survivability and Security (TNF S ²) program. The framework for program test and evaluation planning activities is presented. Identification of related test programs for supporting the TNF S ² program are discussed. A generic data management system is defined. Test support facilities for execution of the program are identified and discussed.		

6

10

15

11

19

17

391884

DM

UNCLASSIFIED

SECURITY CLASSIFICATION OF THIS PAGE(When Data Entered)

19. KEY WORDS (Continued)

Test Planning
Security

Survivability
Vulnerability

Models

UNCLASSIFIED

SECURITY CLASSIFICATION OF THIS PAGE(When Data Entered)

TABLE OF CONTENTS

<u>Section</u>	<u>Page</u>
1 EXECUTIVE SUMMARY	5
1-1 INTRODUCTION	5
1-2 SUMMARY OF RESULTS	5
2 PROGRAM APPROACH	8
2-1 INTRODUCTION	8
2-2 EARLY TEST CAPABILITY TASKS	8
2-3 TECHNICAL APPROACH	8
3 RESULTS	12
3-1 INTRODUCTION	12
3-2 TEST PROGRAM DEVELOPMENT	14
3-2.1 Test and Evaluation Planning Documentation	14
3-2.1.1 Documentation Structure	14
3-2.1.2 Test Planning	15
3-2.2 Issue Analysis	17
3-2.3 TNF Operational Process	21
3-2.3.1 Overview	21
3-2.3.2 Analysis Methods	27
3-2.4 Test Related Areas of Concern	29
3-2.4.1 General	29
3-2.4.2 Discussion	29
3-2.4.3 Summary	31
3-3 RELATED TEST AND EVALUATION	31
3-3.1 General	31
3-3.2 Discussion	32
3-3.3 Summary	34
3-4 DATA MANAGEMENT SYSTEM DEVELOPMENT	34
3-4.1 General	34
3-4.2 Data Management Plan	35
3-4.3 Data Security	37
3-4.4 DMS Hardware Requirements	38
3-5 TEST/EXERCISE FACILITIES	42
3-5.1 General	42
3-5.2 Discussion	42
3-5.3 Summary	48
4 CONCLUSIONS AND RECOMMENDATIONS	49
5 REFERENCES	51

TABLE OF CONTENTS (Concluded)

<u>Appendix</u>		<u>Page</u>
A	CONCEPTS FOR THE PRELIMINARY DATA MANAGEMENT PLAN	A-1
B	TNF OPERATIONAL PROCESS DESCRIPTION	B-1
C	RANGE/EXERCISE FACILITIES	C-1
D	LIST OF ACRONYMS	D-1

ACCESSION for		
NTIS	White Section	<input checked="" type="checkbox"/>
DDC	Buff Section	<input type="checkbox"/>
UNANNOUNCED		<input type="checkbox"/>
JUSTIFICATION _____		
BY _____		
DISTRIBUTION/AVAILABILITY CODES		
Dist.	AVAIL. and/or	SPECIAL
A		

LIST OF ILLUSTRATIONS

<u>Figure</u>		<u>Page</u>
1	Task/objectives relationship	9
2	Overall test and evaluation process	11
3	Functional elements of the TNF S ² early test capability development program	13
4	TNF S ² documentation structure	16
5	TNF S ² issues/structure	18
6	TNF S ² selected issue breakdown	20
7	Issue relationships and categories of basic test concepts	22
8	TNF operational process -- detailed structure of environmental and functional attributes	26
9	Elements and major functions of DMS	36
10	Test/exercise site evaluation matrix	43
11	LORAN C coverage within CONUS	47
A-1	Manual file creation flow	A-6
A-2	Quicklook flow	A-7
A-3	Data base flow	A-9
A-4	Data base structure	A-11
A-5	Quick-look system	A-14
B-1	General structure of two generic functional activities of TNF OP	B-2
B-2	TNF operational process -- detailed structure of environmental and functional attributes	B-7
B-3	Relationship of TNF operational process functional activities and verbal description with NATO/WP TNF environmental conditions to assessment methodologies	B-10
B-4	Operational example -- hypothetical diagram of deployment route from assembly area to GDP	B-13
C-1	Fort Hood area and restricted airspace	C-3
C-2	Fort Ord and Hunter-Liggett area	C-8
C-3	HLMR with impact areas	C-9
C-4	Fort Sill areas	C-15
C-5	Fort Benning area	C-19
C-6	The Eglin AFB test complex	C-29
C-7	Fort Knox landspace, showing restricted airspace	C-35

LIST OF TABLES

<u>Table</u>		<u>Page</u>
1	Relationship of TNF S ² Service issues to operational test and evaluation of critical question areas	23
2	Computer cost comparison for DMS hardware (dollars)	41
3	Facilities summary	44
A-1	Preliminary data requirements list	A-3
B-1	Design characteristics of TNF OP system model and translation to experimental test designs	B-5
B-2	Test objective in operational example -- activity in TNF OP	B-14
B-3	Influence of variance of control variables in operational example -- input state of deployment activity in TNF OP	B-15
B-4	Control variables and associated levels of control variables in operational example -- state variables and decision variables of deployment activity in TNF OP	B-16
B-5	Covariates of operational example -- state variables of deployment activity in TNF OP	B-18
B-6	Response variables of operational example -- rewards' and returns of deployment activity of TNF OP	B-20
B-7	Influence of variance of response variables in operational example -- output state of deployment activity in TNF OP	B-22
C-1	ADTC airspace restrictions	C-34

SECTION 1
EXECUTIVE SUMMARY

1-1 INTRODUCTION.

This report presents the detailed results of the Theater Nuclear Force Survivability and Security (TNF S²) Early Test Capability Development program, one of series of programs designed to support the Defense Nuclear Agency's (DNA) TNF S² program. Department of Defense (DOD) guidance directs that the TNF S² assessments and subsequent management implementation decisions be accomplished through systematic investigations based, to the extent possible, on realistic operational testing, evaluation and analysis. The first year's work (References 1 and 2) scoped the program and defined initial issues/solutions affecting the TNF S². These TNF S² improvement options are oriented toward hardware, procedures, training, and organizational structure.

The Early Test Capability Development program was designed to provide the basic framework for operational test and evaluation of TNF S² enhancement options. Specifically, the objectives are:

1. Develop the resource and management structure necessary for coordinated and thorough planning activities.
2. Identify data sources relevant to TNF S² issues, primarily from past, current, and planned programs being conducted by from past, current, and governmental agencies.
3. Develop concepts for a Data Management System (DMS) with emphasis on the control and handling of classified program data.
4. Evaluate facilities required for conduct of TNF S² tests and evaluations.

The identification of test related deficiencies were ancillary to these primary objectives.

1-2 SUMMARY OF RESULTS.

The TNF S² Test Capability program has identified and addressed primary factors which will influence test and analysis efforts directed

at the identification, evaluation, and recommendation for implementation of identified S² enhancement measures. These factors may be grouped broadly into four question areas pertaining to TNF S² test options:

1. What resource and management requirements are necessary for effective S² test program development and execution?
2. What relevant historical, current, and planned information exists concerning S² enhancement? Where is the information and how may it be accessed?
3. Given the availability of historical and current information of test and analysis data, what is the most effective and efficient system to handle the data or information? How should this system be structured and implemented?
4. What test facilities exist in either CONUS or Europe which are available and appropriate for S² enhancement option tests or analyses?

The above questions are addressed in this report. Recognized limitations based on current TNF program development are discussed, including management of the testing of S² enhancement options; the utility of relevant information or available S² related data; the computer software required to securely access or store such data; and the physical testing environment required to collect S² enhancement related information.

Management and resource requirements for effective S² program development and execution are discussed in section 3-2. This area has been investigated with respect to:

1. Proper organization and development of test documentation.
2. Detailed identification of the inter- and intrarelations of the S² Service issues and areas of concern.
3. A first order identification and development of a methodology to assess S² enhancement measures on those activities which any TNF unit must perform to accomplish its mission.

4. Currently recognized test, analysis, and execution limitations or deficiencies.

In pursuance of these requirements, an operations research model was developed and the first Issue Evaluation Plan (IEP) was drafted and delivered.

A documentation data base consisting of test plans and resource surveys has been established to provide baseline information for the various issues which will be addressed. This baseline data will be expanded to include test data as it becomes available. The test data inputs will come not only from this program but from other agency/DOD TNF program tests and field exercises. Specifically, the types of information will include security, force training, equipment procedures, operational tactics, force-on-force evaluation, and direct and general support. Several programs where these types of data may be obtained are given in section 3-2.

The primary FY79 monitoring candidates have been established and are listed in the current Program Management Plan (PMP). Only limited monitoring efforts have been accomplished to date. The results of one effort were submitted under separate cover.

The preliminary design, to include both the structure and the required operational hardware for a secure DMS, has been defined and is discussed in section 3-4. Concepts for a preliminary Data Management Plan (DMP) are presented. The major concern in this effort has been the design of the DMS with sufficient data storage, processing, and retrieval flexibility for the use of both historical test results and dedicated TNF S² test information to assess the impact of various S² enhancement options.

CONUS and European test facilities have been investigated as to their applicability and availability for the support of TNF S² tests and evaluations. An assessment of near term requirements (without dedicated program instrumentation) and long term requirements (with dedicated instrumentation) has been included in section 3-5.

SECTION 2 PROGRAM APPROACH

2-1 INTRODUCTION.

This section presents the tasks and approaches used in satisfying the Early Test Capability Development program objectives. It has been based, to the maximum extent possible, on existing documentation and related program efforts accomplished to date. Coordinated and approved issues were not available until late in the program; therefore, only preliminary insights into those issues are presented in this report. The methodologies and approach taken in addressing tasks and objectives are generic and encompass the issues generated in References 1 and 2.

2-2 EARLY TEST CAPABILITY TASKS.

The tasks as specified in the Contract Statement of Work are:

1. Task 1 - Identify test alternatives and initiate specific test plans based on preliminary issues from TNF S² scope development.
2. Task 2 - Identify test procedures for early implementation of the test program.
3. Task 3 - Identify early testing of potential near term improvements.
4. Task 4 - Identify test related deficiencies and alternative solutions.
5. Task 5 - Identify requirements and problems associated with a secure data base.
6. Task 6 - Develop the rationale for dedicated TNF S² test exercise facilities.

The relationships of these tasks to the Early Test Capability program objectives are shown in Figure 1.

2-3 TECHNICAL APPROACH.

The basic requirements for timely and effective program execution were identified and evaluated. The approach and methodology of the

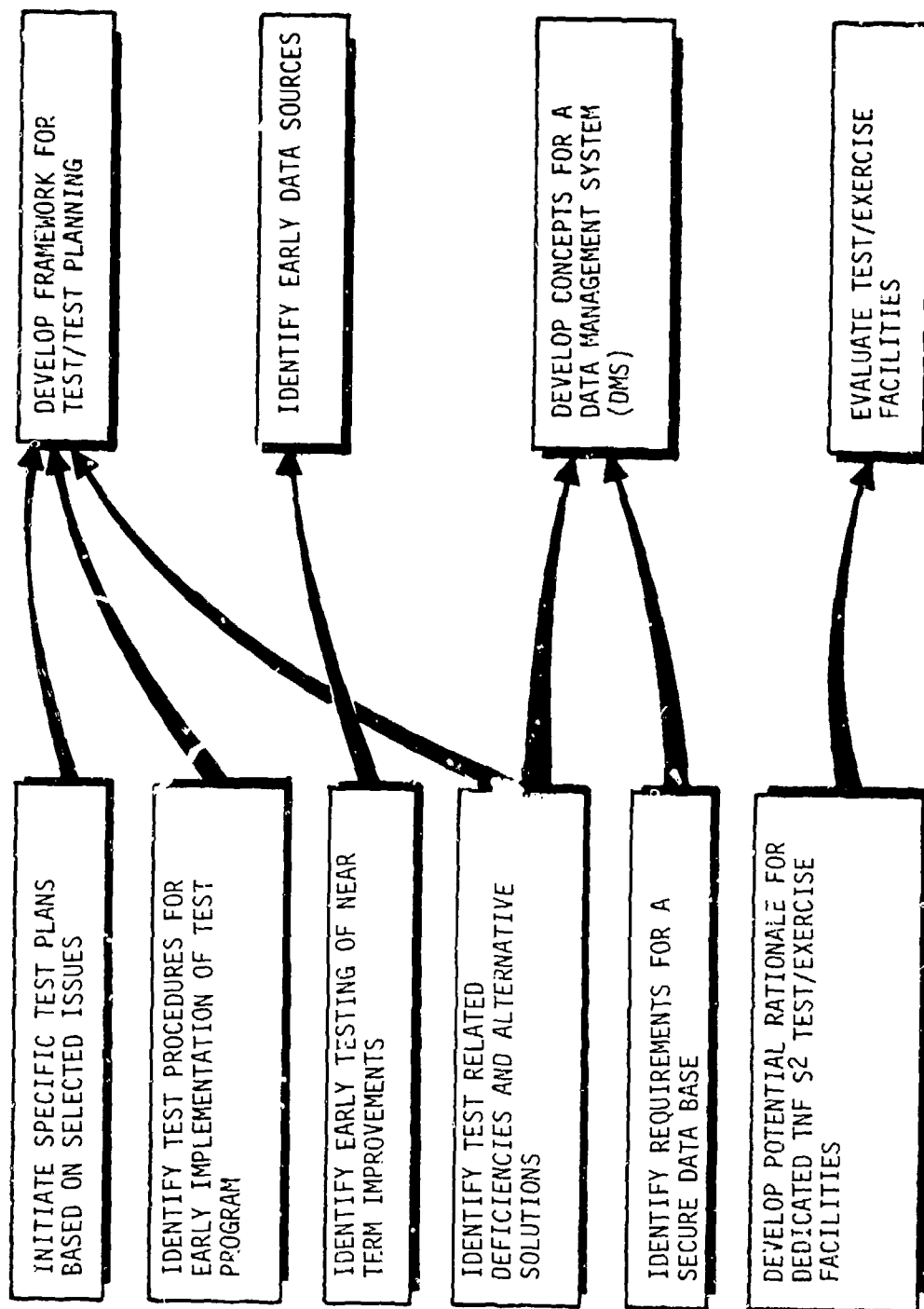

Figure 1. Task/objectives relationships.

Early Test Capability Development program is an extension of the original Scoping Phase (Reference 1). Information presented in Reference 1 served as the baseline for developing the generic elements of the test program. Test program development concepts were derived through analysis of issues with respect to TNF elements, similarities of issues, and apparent primary areas of concern. Results of the issue analyses were then applied to the overall test and evaluation process (Figure 2) to establish test planning methods for both individual issues and the overall program. The methods developed provide the flexibility for handling new/modified issues, program modification, and changes in program direction. The need for monitoring and adjunctive testing was reaffirmed and candidate programs identified.

Resource and test facility requirements for testing were further refined from the scoping phase and organized into three areas:

1. Facilities required for near term testing (without a dedicated instrumentation system).
2. Facilities for mid and far term CONUS testing (with dedicated instrumentation).
3. European facilities for limited evaluations.

A generic Data Management System was developed for early collection of TNF test data and the associated methods for handling, controlling, and insuring security of such information.

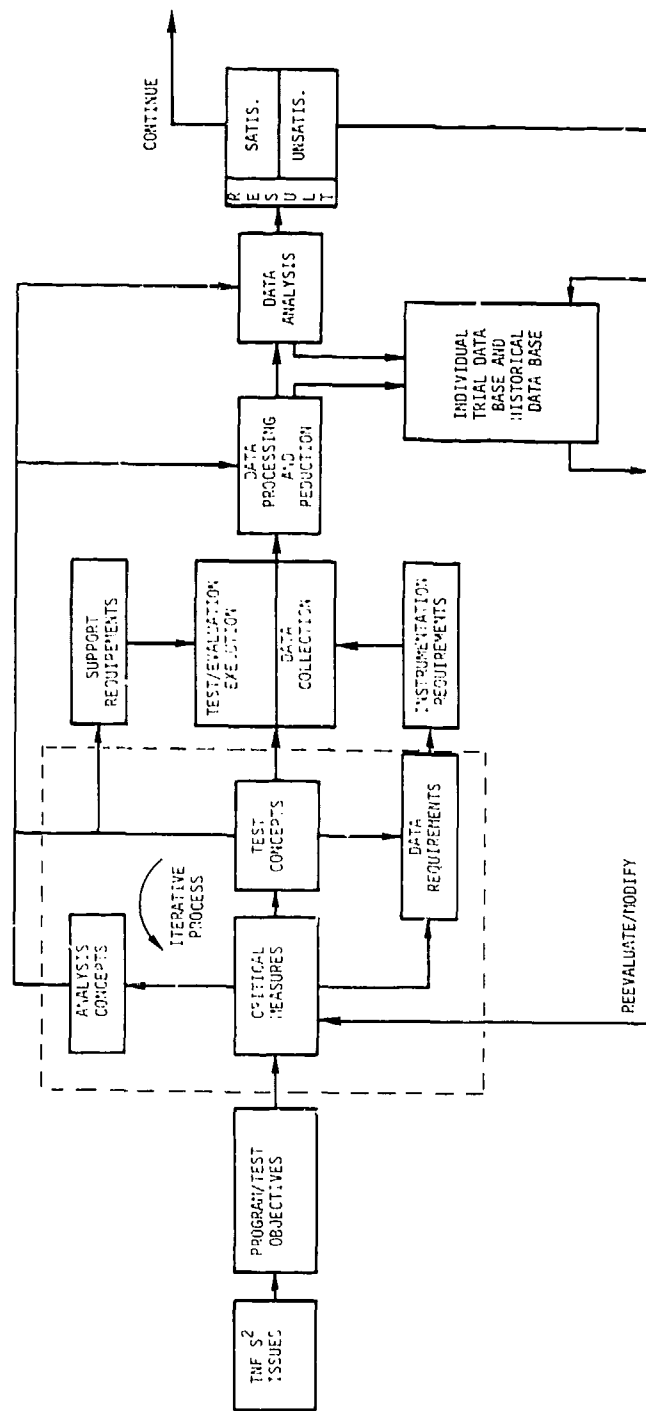

Figure 2. Overall test and evaluation process.

SECTION 3 RESULTS

3-1 INTRODUCTION.

The results of the TNF S² Early Test Capability Development program are organized into four objective areas:

1. Test Program Development
2. Related Test and Evaluation Programs
3. Data Management System Development
4. Test/Exercise Facility Requirements

Functional elements of these program objective areas are shown in Figure 3.

Test program development documents the overall program planning, test requirements, and methods for approaching detailed test and evaluation planning to assess TNF S² enhancements. Basic information is presented for planning the documentation structure, organization, and content for use as guidelines in all planning activities. Methods to provide the necessary compatibility, continuity, and traceability of program planning activities are presented (section 3-2.1). An analysis of all the current issues was accomplished to provide insight into the total program areas of concern. This analysis provided the baseline for characterizing the TNF elements, issues, and their interactions. This analysis was used in developing the operational relationship of issues to the various TNF elements (section 3-2.2 and Appendix B). The TNF characterizations represent an initial step in developing analytical techniques for use in test design, variable identification and analysis, and the analytical treatment of test data (section 3-2.3). Test related deficiencies were identified and are presented along with possible solutions (section 3-2.4).

Related test and evaluation programs were investigated for applicability to the TNF S² program (section 3-3). Generic requirements for near term monitoring and adjunctive testing are presented in this section.

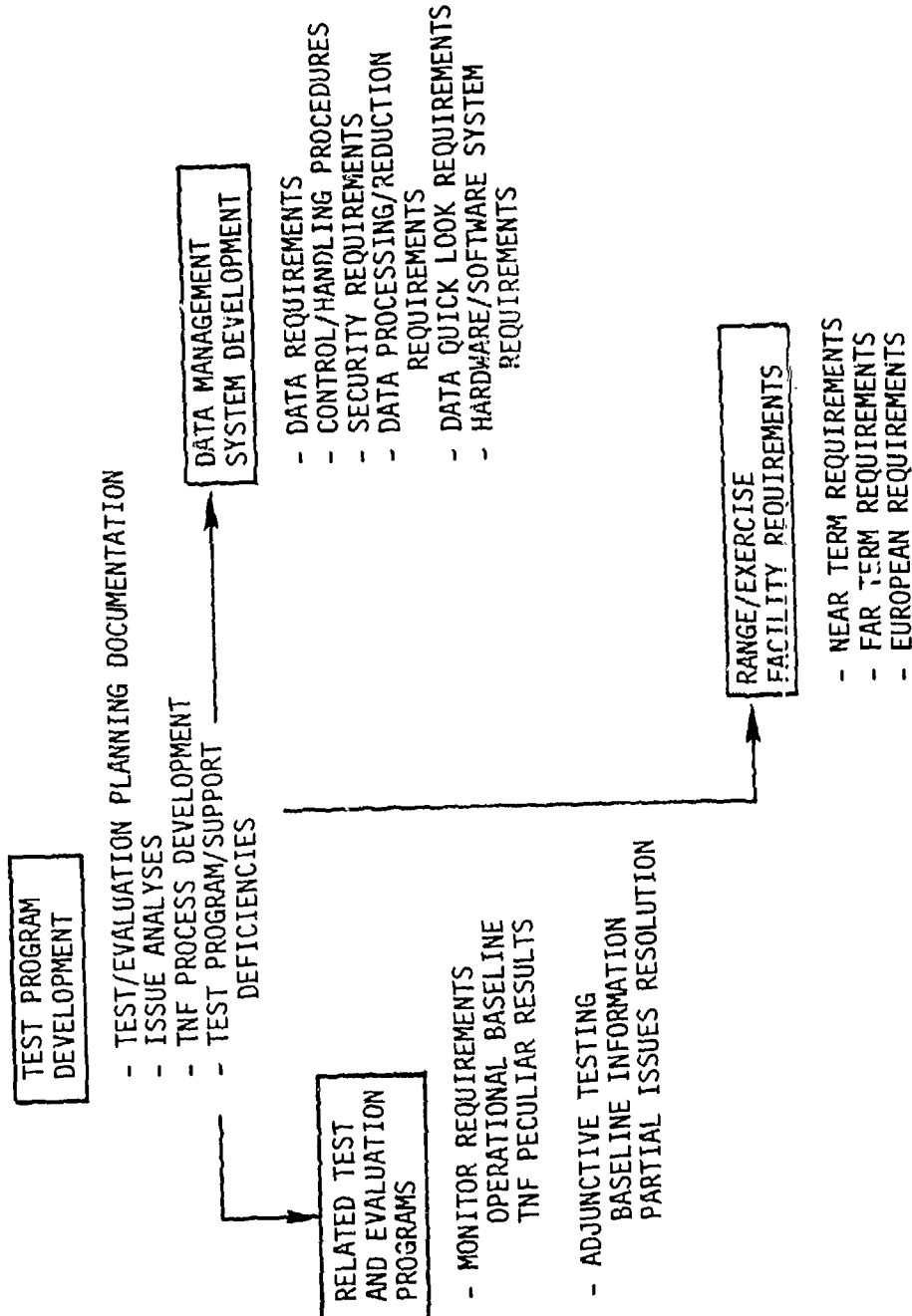

Figure 3. Functional elements of the TNFS² early test capability development program.

A Data Management System for the total TNF S² program was developed. The concepts for a preliminary DMP are presented in Appendix A. The basic requirements are discussed for data control and handling, requirements identification, security controls, processing and reduction, and quick-look. Hardware system requirements for support of the overall program were also investigated and recommendations provided (section 3-4).

An investigation of range/exercise facilities to support the TNF S² program was conducted, and detailed descriptions of likely test ranges are presented in Appendix C. The range/exercise areas are discussed in terms of physical characteristics, support capabilities, and special capabilities and limitations. Range/exercise area requirements were also investigated for near term testing, where a dedicated TNF S² instrumentation system will not be available, and far term testing, which will have a dedicated instrumentation capability (section 3-5).

3-2 TEST PROGRAM DEVELOPMENT.

3-2.1 Test and Evaluation Planning Documentation.

3-2.1.1 Documentation Structure. The basic approach applied in the development of test and evaluation documentation is defined in Reference 1. The documentation hierarchy currently consists of the Master Evaluation Plan (MEP), IEP, and detailed test, evaluation, and analysis plans. The MEP is the executive level document which provides the framework for the total evaluation program conduct and organization. Included in the MEP are the current list of issues, their priorities, preliminary evaluation methods, and data sources. The MEP serves as the primary management document for maintaining the current status of all the issues. As such, it is a working document which is periodically updated to reflect issue changes, new issues, realigned priorities, and provide direction for development of IEP's. The IEP's provide the initial guidelines for evaluation of an individual issue or group of similar issues. It includes a systematic structuring of the issue to include methods and measures of effectiveness (MOE) for evaluation.

IEP's may provide the guidelines for tests, analyses, modeling requirements, or any combination of these methods required to totally evaluate an issue.

Detailed test and test management plans are required once an IEP is coordinated and approved, and a responsible lead agency designated to direct the issue evaluation. These plans (of which several may be required to address one IEP) can be test plans, test designs, study plans, monitor plans, etc.

The complexity and sheer numbers of planning documents to be generated by many different organizations, agencies, and contractors throughout the TNF S² program dictates the need for a definitive documentation management scheme. To insure compatibility, continuity, traceability, and management control of the many planning documents, the structure for program plans shown in Figure 4 should be followed. The structure is based on a "modular" approach successfully used in other multi-faceted, complex programs. The content and organization of the initial IEP's are consistent with this outline and all subsequent IEP's should follow this basic format. Detailed planning documents, implementation plans, resource allocation plans, etc., should be attached as appendices to the IEP when applicable. This will insure that all plans relevant to an IEP are an integral part of the package. It will also provide a single package for management tracking in the MEP. Since the MEP provides numbered categorization of the issues, the IEP's and subsequent detailed plans can be controlled by the issue identification number. This method can be expanded to provide tracking of test and study reports.

3-2.1.2 Test Planning. Preliminary issues were received from USAFE in May 1978. Work was initiated on IEP's for the first three issues. These issues involved both testable and initial study/analysis issues. A draft IEP for the testable issue was developed and delivered under separate cover (Reference 3). The other IEP (soon to be delivered in draft form) will address one of the USAFE issues through study/analysis. The format is similar to the test IEP. This format is a representative example for all study or analysis type IEP's.

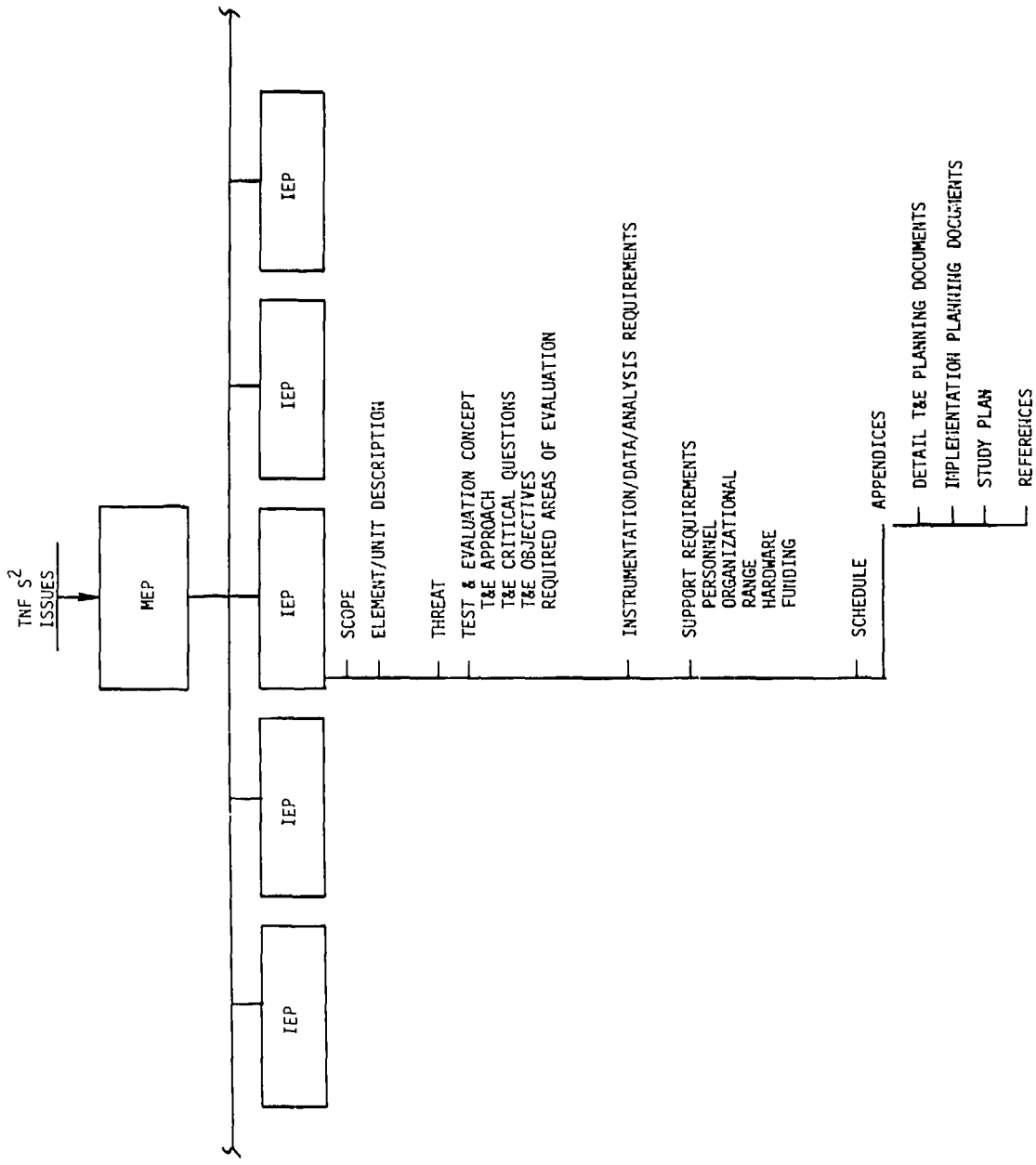

Figure 4. TNF S² documentation structure.

3-2.2 Issue Analysis.

This section presents the general procedures followed during the Early Test Capability program to:

1. Evaluate the TNF Service issues and areas of concern to determine their inter- and intrarelationships.
2. Orient such inspection and investigation of the TNF Service issues to specific TNF units and elements.
3. Determine, from an operational test, evaluation, and analysis perspective, the critical questions pertaining to the assessment of current or planned S² enhancements.
4. Identify additional critical questions pertaining to S² enhancement possibilities.
5. Define and develop a flexible working methodology to operationally assess current or planned S² enhancements.

This procedure has resulted in the development of preliminary operational descriptions of inter- and intrarelated goals and objectives of TNF unit activities required for mission accomplishment. Future expansion of this effort will be oriented toward the specific goal of developing integrated operational tests and analyses to assess the relative worth (in terms of the threat) of S² enhancement options for the TNF.

Figure 5 presents a simplified representation of the structure of the Service issues and areas of concern as it appears in the MEP. The issue structure is categorized by issue elements which are defined as:

1. Delivery Systems: The military personnel and hardware required to deliver and detonate a warhead at the designated time and place in the target area. Included are aircraft, missiles and howitzers and their crews, and ADM teams. Issues concerned with delivery systems address those S² enhancements to the delivery system hardware (existing and future) and associated organization, tactics, and training of personnel.

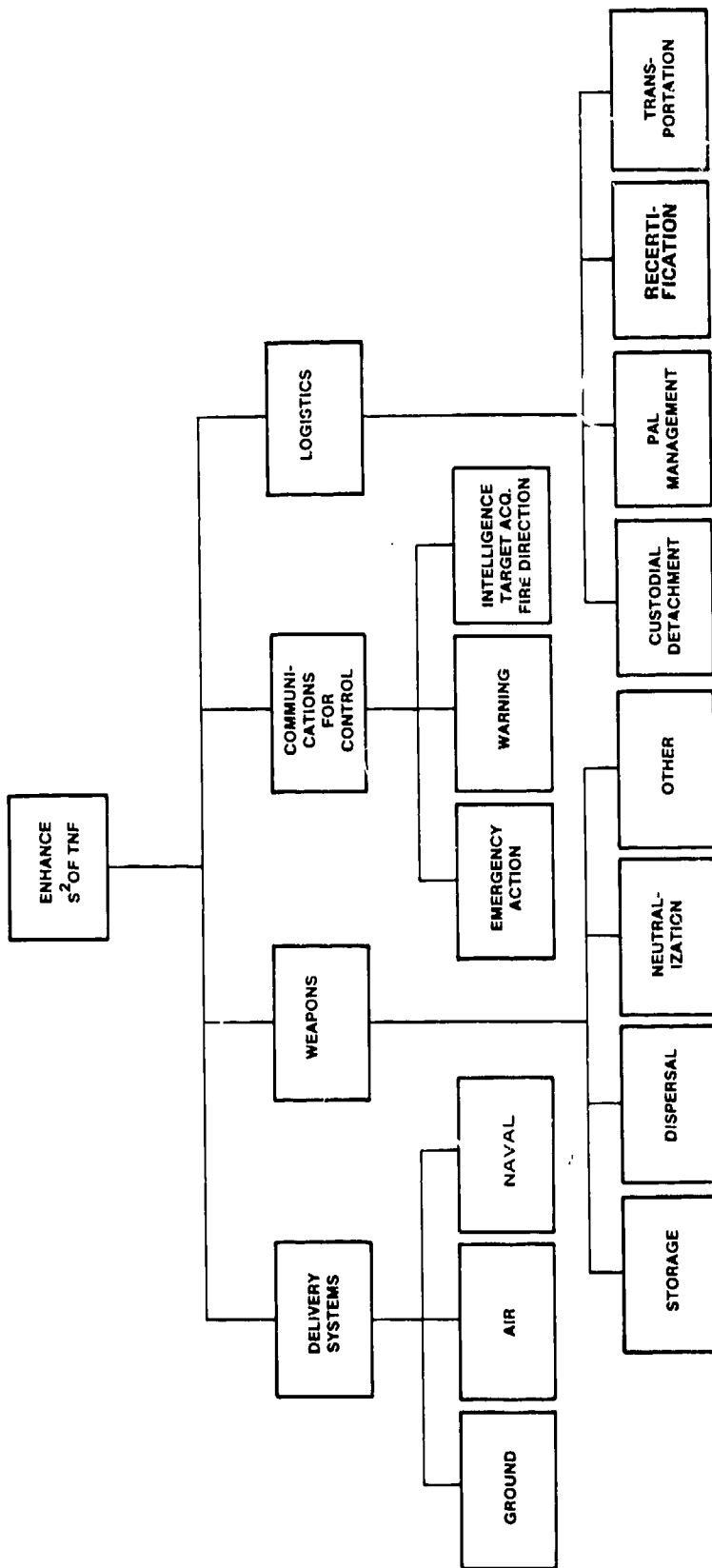

Figure 5. TNF S² issues/structure.

2. Weapons: The warheads, adaption kits, and other contiguous paraphenalia (bomb shapes, missile warhead sections, projectile bodies, and mines) necessary to assure compatibility with the delivery system(s). Issues concerned with weapons address those S^2 enhancements to the weapon hardware (existing and future) relating to the environments generated by the Stockpile to Target Sequence (STS).
3. Communications for Control: The equipment and personnel required for processing and disseminating information relating to activities essential to the peacetime and wartime functioning of the TNF. Issues concerned with communications for control address those S^2 enhancements to the hardware (existing and future) and associated organization, procedures, and training of personnel.
4. Logistics: The equipment and personnel required for the storage, maintenance, repair, and distribution of weapons to delivery systems. Included are fixed facilities, weapon (component) containers, material handling, and transport vehicles. Issues concerned with logistics address those S^2 enhancements to the hardware (existing and future), facilities and associated organization, procedures, and training of personnel.

Figure 6 presents a representative breakdown of selected Service issues or areas of concern and representative enhancements of specific weapons delivery systems. The purpose of this illustrative breakdown is to describe the type of parameters which affect the survivability of the delivery systems (or location of delivery systems). It becomes apparent that the issues identified have a common set of potential enhancements and, similarly, a common set of operational test parameters.

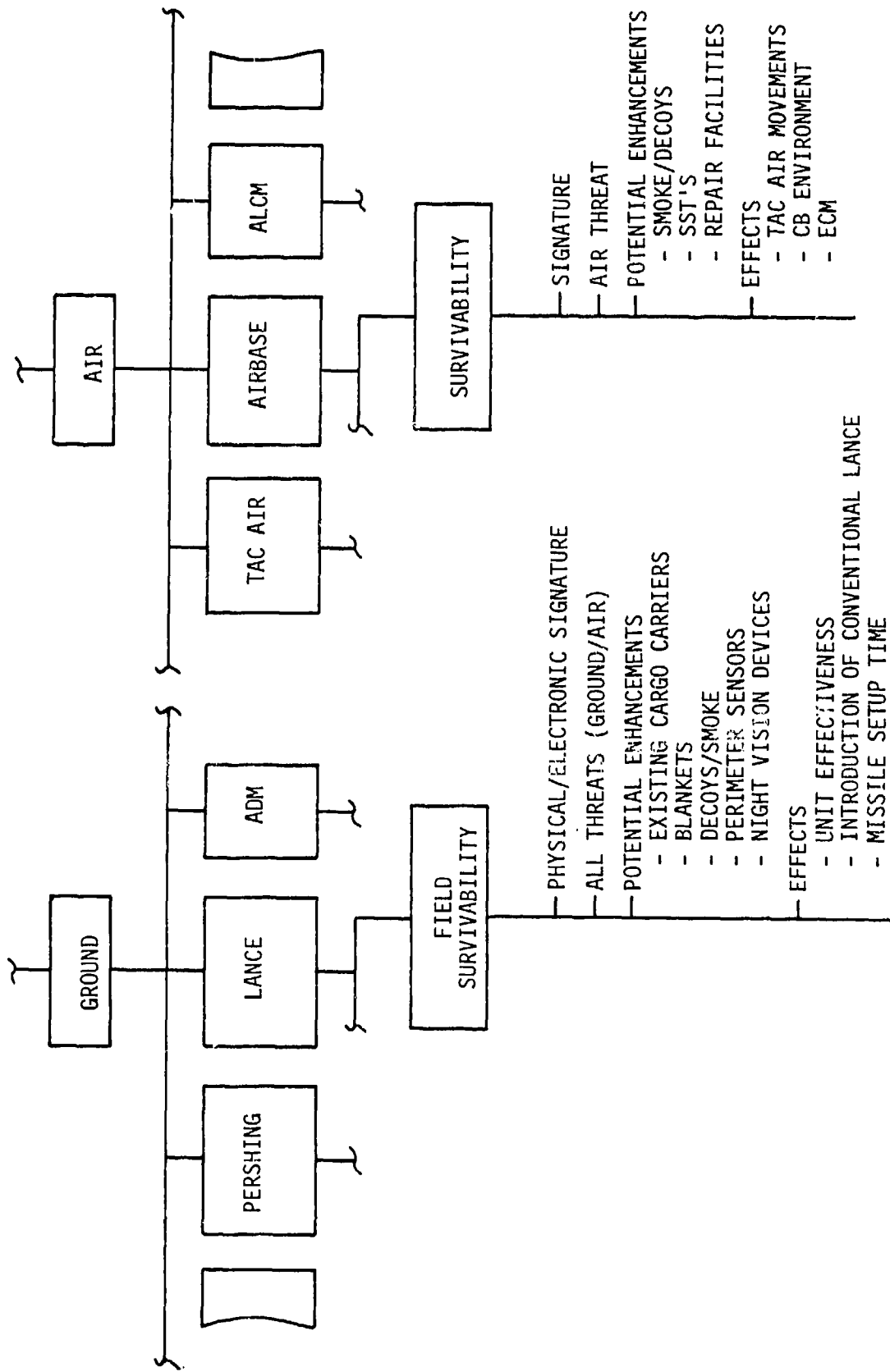

Figure 6. TNF S² selected issue breakdown.

Figure 7 illustrates the issue relationships and categories of basic test and evaluation results. This relationship facilitates formulation of test and evaluation critical questions and application of test and evaluation results in measuring the effectiveness, suitability, and deficiencies of TNF S^2 enhancements in an integrated fashion. This approach poses critical questions on operational test results related to mission performance, doctrine and organization, personnel selection and training, and vulnerability. These questions are then directed to particular Service issues and to system security, survivability, availability, and effectiveness. This approach provides direct information for assessing TNF S^2 improvement options in the related analytical assessment program.

Table 1 combines the information of Figures 6 and 7 and is used to classify issues relative to major areas of concern or critical questions. From Table 1 it is apparent that key S^2 areas of concern have not yet been addressed (e.g., survivability of C^2) and that the program must be structured to identify and accommodate such additional key issues.

Two conclusions may be drawn from an analysis of the preceding discussion:

1. The TNF service issues and areas of concern for S^2 enhancement possibilities are sufficiently inter- and intrarelated. Test, evaluation, and analysis efforts must totally assess these inter- and intrarelations.
2. The TNF operational relationships must consider the TNF characteristics of operational readiness, survivability, security, availability, and force effectiveness.

These conclusions form the basis of the definition and development of a methodology to operationally determine or assess S^2 enhancements to the TNF.

3-2.3 TNF Operational Process.

3-2.3.1 Overview. This section presents the first order definition of the TNF Operational Process (TNF OP) -- a dynamic, multistage

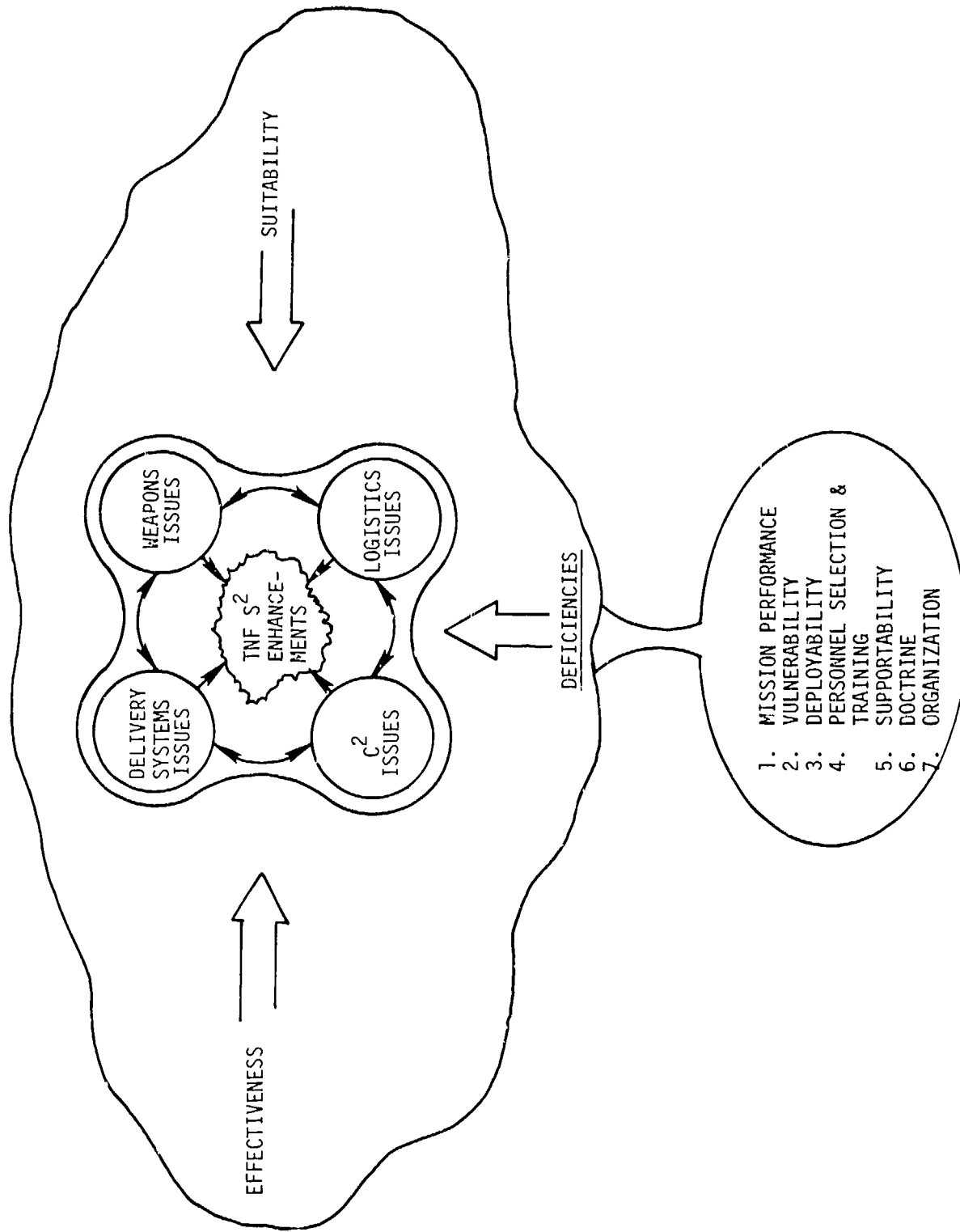

Figure 7. Issue relationships and categories of basic test concepts.

stage methodology which describes the functional elements necessary for any TNF unit to accomplish its mission.

The TNF OP is a preliminary methodology developed for the purpose of assessing the impact of a given S^2 enhancement option and its application to the total TNF through the MOE and analytical assessment programs. It should be applied during any operational test, evaluation, analysis, or study effort concerning assessments of the relative benefits of S^2 enhancement options. The methodology is, at present, sufficiently general so as to accommodate either Army or Air Force weapons systems' characteristics and the appropriate Service operation's influence on the use of such systems.

The goal in the use of the TNF OP methodology is to assist in the choice of the best set of S^2 enhancement options for recommended management implementation so as to maximize the S^2 of the TNF. This goal is constrained by operational constraints, technological constraints, and resource constraints of the TNF. The TNF OP may be viewed as a structure of functional activities and environmental conditions which are managed, coordinated, and connected in such a fashion that the available resources will be applied toward the TNF goal of mission accomplishment in an effective, efficient, and balanced manner.

The manner in which any TNF unit (Army or Air Force) performs is defined by three general variables:

1. Personnel
2. Policies
3. Machines

TNF organization and tactical units are composed of diverse personnel trained and tasked to effectively perform a complex set of actions based on their skills and training. Policies of the TNF units are those procedures, tactics, and doctrines that the personnel must adhere to in the accomplishment of their designated action-oriented tasks. The machines of the TNF are the variety of weapon systems and communication equipment which are used by the personnel in accomplishing their assigned mission.

Any TNF organization or unit operates with weighted combinations of personnel, policies, and machines; therefore, any unit's successful mission accomplishment is constrained by the associated combinations of the variables. Any enhancements to the unit's S^2 performance may be described using the TNF OP methodology by the differences obtained with various combinations of personnel, policies, and machines.

The current structure of the TNF OP methodology and state model is presented in Figure 8. It is designed around the involvement of personnel, policies, and machines in those activities required to support the accomplishment of a military mission. The activities contained in the TNF OP structure apply in varying degrees to all TNF units, whether Army or Air Force, and are illustrated in the center of Figure 8. Listed below these activities in this figure is an illustrative scenario relating the generic TNF OP activities to a set of operational activities of a TNF Army Field Artillery unit.

A detailed description of the application of the TNF OP methodology, to include accepted military definitions of TNF activities is contained in Appendix B. An operational example of TNF activities is also contained in Appendix B to illustrate the classification and identification of those operational variables influencing the mission success of a TNF 155 mm M-109 (SP) Howitzer battery. This same capability exists for air units.

The structure of the TNF OP is so designed that the degree of success of one functional activity is dependent on the degree of success of the preceding functional activity. The accomplishment of a unit's mission may then be decomposed into a series of functional activities in which limitations and enhancements are dependently related to the unit's operational activity.

The utility of such a characterization of the functional activities required for a unit's mission accomplishment is threefold:

1. Evaluation of the activities and resources required in any activity of the TNF OP allows for credible assessments of the inter-activity and connectivity of current or

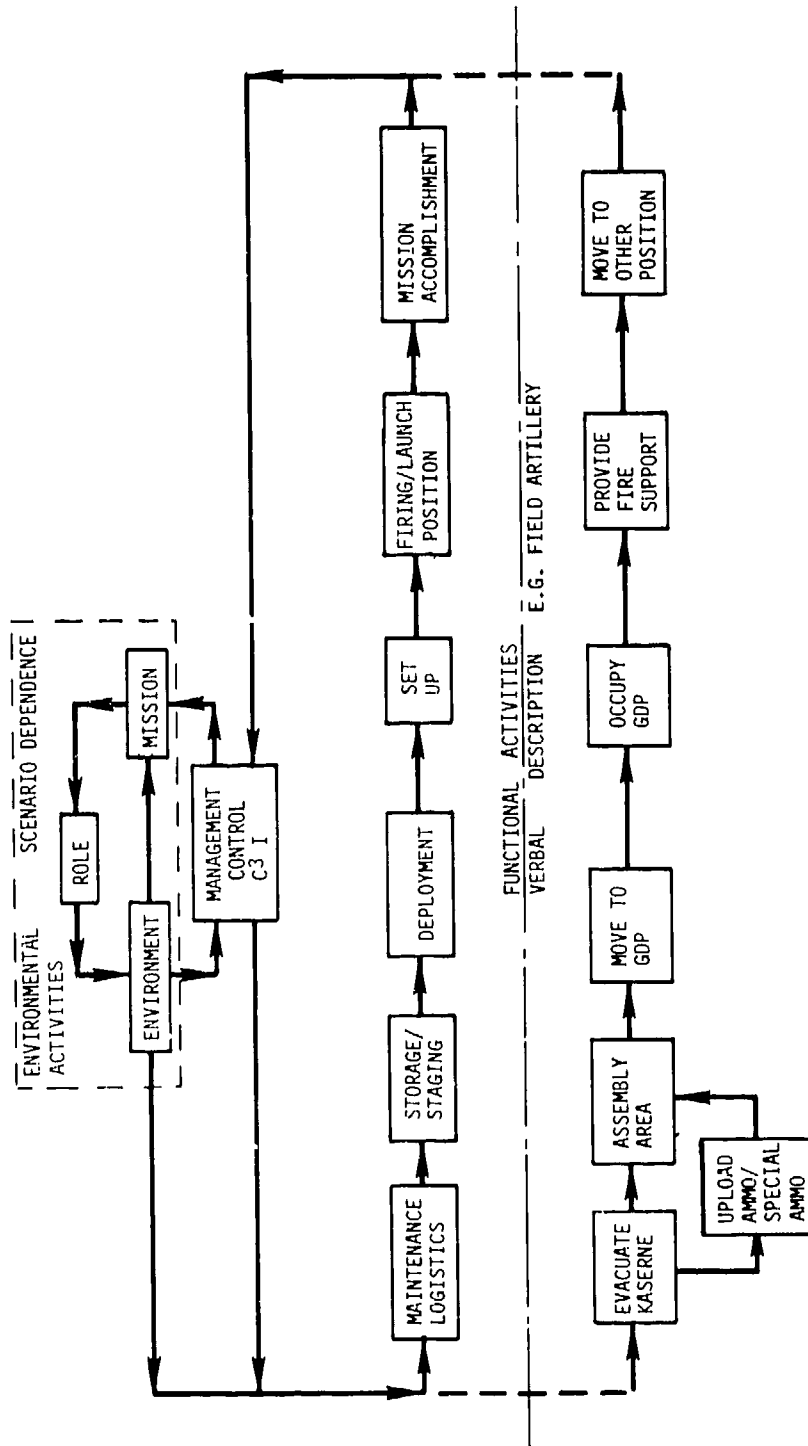

Figure 8. TNF operational process -- detailed structure of environmental and functional attributes.

projected TNF Service issues for S² enhancement. This is because the TNF S² Service issues and areas of concern are inter- and intrarelated to each other; any valid operational assessment must consider all of the interactions.

2. The multistage structure of an Army or Air Force mission is explicitly developed in the TNF OP methodology structure to accommodate functional activity dependent test design and evaluation approaches and the development of process and systemic MOE (Reference 4) to be investigated during operational testing. As such, this design principle allows for interdependent testing of service issues to be performed either concurrently or sequentially. This results in an integrated, rather than an independent, evaluation and analysis of TNF S² deficiencies, limitations, or possible enhancements.
3. The TNF OP structure is also designed to accommodate security, availability, survivability, and force effectiveness algorithms. These algorithms may apply to any unit during the performance of one or more of the identified operational activities of the TNF OP structure.

The current methodology of the TNF OP is oriented toward addressing only the first-order impacts and consequences of the extremely complex TNF system of personnel, policies, and machines. Extended development and application of this approach is intended to:

1. Provide a greater understanding of the magnitude of the activity interactions.
2. Refine the characterization of information flow from activity to activity in the TNF OP structure.

3-2.3.2 Analysis Methods. The following analysis methodologies are identified for application in the operational test, evaluation, and analysis of candidate S² enhancements to the TNF. The methodologies presented are considered relevant to assessing the utility and impact of S² enhancement options for tactics, deployment, and doctrine development.

The analysis of S^2 enhancement options may be viewed as assessments of the results obtained when the option is implemented or not implemented relative to the primary variables of policies, personnel, and machines as they affect mission accomplishment.

Statistical experimental development and design techniques will be applied during the test design phase. Basic structures of experimental designs are contained in Reference 5 and 6. Sampling techniques developed for the implementation of the experimental designs and data collection are contained in References 6 and 7.

Numerous statistical evaluation methodologies are considered relevant to the analytical assessment of S^2 enhancement options including multivariate methods (References 8, 9, and 10), multiple-attribute utility theory (Reference 11), evolutionary operation and response surface methodologies (References 5, 8, and 10), stochastic processes (References 8, 12, and 13), and game and strategy oriented practices (References 9, 13, 14, and 15). System assessment methodologies which apply directly to the analytical assessments (including the overall MOE framework) of S^2 enhancement options include dynamic programming (References 11 and 17), pattern recognition and classification (References 14 and 15), sensitivity analyses of test outcomes (References 11, 12, 13, 17, 18, and 19), incorporation of expert opinion (References 9, 11, and 20), and application of humanistic systems analysis (Reference 21).

Numerous computer software programs are available for such evaluations and analyses to be efficiently performed. These include the Bio-Medical Program Series (BMD-P), the Statistical Package for the Social Sciences (SPSS), OMNITAB, and such simulation programs as GASP-IV, Q-GERT, and SIMSCRIPT. The preceding software packages are compatible with all envisioned data management systems and may be readily applied during the test and evaluation efforts. Other software packages are to be developed within the analytical assessments program as needed for parallel support to operational tests and evaluations and for assessment and application of their results.

3-2.4 Test Related Areas Of Concern.

3-2.4.1 General. Areas of concern were identified that relate to total program test and evaluation planning activities, test and evaluation conduct, and results reporting/assessments. These areas of concern are generic in nature and not issue specific. They refer to the necessary actions and sequence of events to plan, execute, and analyze the test results. These areas of concern are discussed according to the primary areas of test planning and design, data collection, and techniques anticipated for treatment of test data. The following discussions state the area of concern, the related discussion, and recommended solution and justification.

3-2.4.2 Discussion.

1. Concern: Adequate definition of each TNF element/system.
Discussion: Planning activities for any type of test or evaluation requires a complete definition of the test item or system. Complete definition includes a detailed description of the element/system, its operation, its interfaces, and its mission. The required level of definition must indicate what and the extent that the external and internal factors influence its operation.
Recommend Solution: The characterization of TNF units provide the initial guidance to insure the definition and identification of all the necessary factors. In certain cases the effects of some of the identified factors will not be known. These unknown quantities or qualities are documented and become test constraints which can be used by higher level organizations for proper interpretation of the data.
2. Concern: Duplication of tests due to addition of new issues related to issues already evaluated.

Discussion: The possibility of additional issues being developed which are closely related to issues already addressed or planned may result in needless expenditure of resources.

Recommended Solution: By using the basic TNF OP methodology, sufficient flexibility is available in planning to allow for addition and/or modification of issues. The issues enter the TNF OP as independent variables. If a new issue appears after planning but prior to test execution, only minor changes in the test design matrix would be required. If the new issue appears after the test has been completed, sufficient information may be available to address the new issue by analytical means rather than by test repetition.

3. Concern: Control and handling of data generated during the TNF S² program.

Discussion: One of the major tasks for the Early Test Capability Development program is the identification of the requirements and problems of a secure data base for the TNF S² program. To properly assess this task it was necessary to address the total program requirements for data control. Section 3-4 of this report presents the development of a DMS to support the total program.

Recommended Solution: Section 3-4 presents the concepts and data management planning necessary to control and handle the data generated from this program.

4. Concern: Analytical treatment of TNF S² data.

Discussion: Analysis of the total issues list indicates additional analytical techniques, other than the classical techniques, for treating test data and providing assessments are required. In most of the issue areas which appear testable, data treatment will be required for combinations

of deterministic, humanistic, and probabilistic types of data. Combining these three data types to provide a total and credible assessment of specific issues will require state-of-the-art mathematical treatment. Additionally, the collection of operational baseline data would provide invaluable information in development of test plans and subsequent analysis and assessments of the improvement measure.

Recommended Solution: The MOE and Analytical Assessment Program, compatible with use of the TNF OP model, should provide the basic information and techniques for merging and treating these individual analyses. The MOE framework has been developed to the point that work can begin on data base collection and computer implementation. In addition to T&E efforts, monitoring training exercises could provide sufficient baseline information to develop and validate analytical techniques.

3-2.4.3 Summary. The areas of concern addressed in the preceding paragraphs are a first step in identification of program deficiencies. They are generic and not test or analysis specific. As test planning for individual issue analysis progresses, more test specific deficiencies will be identified and solutions and/or alternatives defined. Discussion of deficiencies in the test/exercise facilities is presented in Section 3-5.

3-3 RELATED TEST AND EVALUATION PROGRAMS.

3-3.1 General.

The primary purpose for evaluating and monitoring TNF related programs is to provide basic information, partial answers, and early data sources for specific TNF S^2 issues. Monitoring provides an inexpensive method to address portions of the TNF areas of concern and prevents duplication of efforts. The programs identified for possible

monitoring in FY78 are presented in Reference 1. TNF issue specific monitoring activities were not accomplished due to the Service delay in identifying, coordinating, and approving issues. Extensive literature searches, however, were accomplished to provide information relative to the generic set of TNF S² issues and one actual monitoring effort was conducted in the area of physical security.

Documentation from the Pershing Survivability Evaluation Program conducted in September/October 1977 is being reviewed for applicability to the TNF S² program. A TNF resource survey was initiated, as part of another TNF S² effort, which provides information relating to available TNF program related documentation and does contain specific test references. The single monitoring effort undertaken in FY78 was for the Base and Installation Security System (BISS) program which consists of over 30 separate joint service projects. The results of this monitoring effort are being submitted under separate cover as a part of the FY78 basic TNF S² program. This is the first of a series on monitoring efforts designed to initiate/ establish an operational data base for application to future test planning efforts.

3-3.2 Discussion.

The primary purpose of evaluating and reviewing test documentation from related past, present, and planned programs is to determine their applicability as early data sources for TNF specific issues. Detailed investigations into related program documentation was conducted on a limited basis. A documentation data base consisting of available test plans and results of the resource surveys has been established to provide the baseline information for use with these issues.

Several ancillary uses for monitoring activities have been developed primarily with respect to the identification of test related deficiencies presented section 3-2. Sending analysts and engineers into the field to monitor (and possibly participate in) TNF related tests, training or operational exercises is highly desirable for several reasons.

First, and most important, monitoring allows the collection of operational baseline data relative to the current issues. The use of specifically designed data questionnaires completed by participants of training or operational exercises, can provide valuable information for an operational data base. Second, monitoring activities would give planners a realistic view of TNF units and an indication of the type of constraints which would affect testing or evaluation of these units. Third, monitoring provides a firsthand view of the hardware, force structure, procedures, and internal and external controls under which the unit operates. Finally, this activity provides a vital link of personal contact between organizations.

The primary candidates for monitoring in FY79 are presented in the latest revision of the Program Management Plan. Although most of these monitoring efforts address specific issues, they are also valuable sources for establishing and supporting an operational data base. The following additional monitor efforts are suggested initiatives which should provide valuable inputs to the establishment of an operational data base.

Army Military Police training at Ft. McClellan, Alabama can provide information concerning security, force training, equipment, procedures, and tactics. Likewise, the Air Force Security Police training, primarily conducted at Camp Bullis, Texas, can provide similar information. Both of these training programs run continuously throughout the year. Both training programs include, as a part of the training syllabus, force-on-force evaluation (usually with the instructors acting as the aggressor force). Neither of these training programs have force-on-force type instrumentation and results of the training exercises are subjective.

Significant baseline information can be obtained by monitoring units at the Ft. Sill, Oklahoma, Field Artillery School and Training Center. This effort could provide basic training and procedural type information. The III Corps Artillery, also at Ft. Sill, consists of 8-inch, 155 mm, and Lance battalions (tactical units) and Pershing training

elements which could provide information relating to the General Support mission of Field artillery. Ft. Sill also houses the Field Artillery Board which is engaged in operational testing and has a limited instrumentation capability. Additional information could be obtained at Ft. Carson for field artillery units with Direct Support Missions.

Specific baseline information which could be derived from these monitor efforts include force structure and composition of units, procedures and tasks required for all aspects of the units mission, equipment and resources required by these units, insights into some of the primary variables which effect the units operation, and constraints (operational, procedural, or safety) which may effect operational testing of these units.

Additional baseline information can be obtained from the large European exercises such as REFORGER/CRESTED CAP. These exercises are candidates for FY79 monitoring as presented in the Program Management Plan; however, they are repeated here to emphasize their use in establishing an operational data base.

3-3.3 Summary.

Issue related monitoring efforts to date include only some generic issues.

It is recommended that planning, forms design, and monitoring activities begin as soon as possible to continue development of an operational data base for the TNF S² program. Near term monitoring efforts at Ft. McClellan, Camp Bullis, Ft. Sill, Ft. Carson, and Europe should be implemented as soon as possible to continue the development of an operational data base, to provide planners with a realistic view of the operational processes and constraints, and to provide personal contact between many of the organizations which are or will be involved in the TNF S² program.

3-4 DATA MANAGEMENT SYSTEM DEVELOPMENT.

3-4.1 General.

Data management, refers to the control of data from acquisition through reporting results and subsequent disposition of the data. It

encompasses activities throughout the TNF S² program including data requirements identification and tracking, physical data acquisition, data processing, data quality control, data analysis, and report preparation. To be totally effective, the DMS must be capable of controlling not only test generated data, but also information derived from studies, analysis, modeling and simulation, and must become the single-point repository for all reports generated during the program. The major elements of the DMS system are presented in Figure 9. The DMP is the vehicle by which data requirements, activities, procedures, and disciplines are defined and continuously refined to insure effective management of data in support of program operations.

The following paragraphs describe the development of the DMS including the DMP, security considerations, and DMS hardware requirements.

3-4.2 Data Management Plan.

The DMP is designed to be a working document supporting the preparation, conduct and assessments of the TNF S² program. Concepts for the plan, presented in Appendix A, are currently generic in nature; however, as the program matures, it will be updated periodically to provide the necessary guidance for control and processing program data. The DMP currently encompasses the following activities:

1. Data Acquisition. Identifies data requirements and develops Data Requirements List (DRL). The DRL identifies the detailed data element, its character, source, and procedures for acquiring it.
2. Data Collection. Describes procedures for collection, handling, and transport of data to the processing center.
3. Data Reduction/Processing. Describes procedures for translation of raw data into a structured format, including both digital type raw data and manually recorded data.
4. Data Base Management. Provides computer filing of all records, data, or elements of data generated during the program. Contains a user-end facility for direct access of all data.

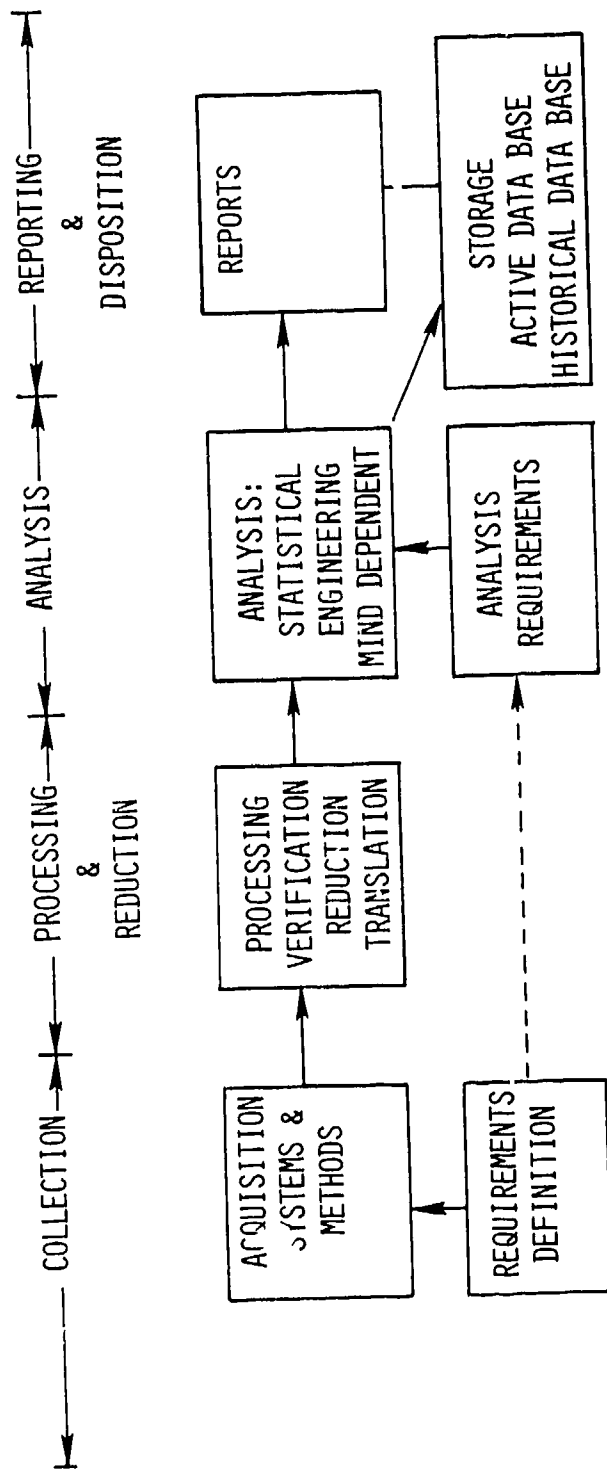

Figure 9. Elements and major functions of DMS.

5. Quality Control. Provides comprehensive procedures and processes for insuring data quality. Provides for the detection of discrepancies, tracks instrumentation system status, and establishes data validity criteria.
6. Quick-Look Analysis. Provides the basis for defining data requirements, data flow, data quality control checks, test validation procedures, and input/output requirements to meet posttest quick-look objectives.

3-4.3 Data Security.

Data security refers not only to the handling and control of classified information but also to the prevention of unauthorized access which might result in lost/misplaced data. Most important, data security minimizes the occurrence that data might be put in a compromised position (interpreted prior to justification and validations or put in an improper context). To insure security, all facets of data management must be strictly controlled. This includes acquisition and handling process, use of special codes for computer access, and secure storage/library facilities. These items are addressed in the development of the DMS and DMP.

To effectively address the control and handling of classified data, it was necessary to make some general assumptions concerning what type of data will be classified in order to determine the impacts on the DMS. These assumptions are:

1. Video film (or other audio-visual devices) of field testing for data collection or documentary purposes may be classified.
2. "First time out" improvement testing will not be run in Europe due to possible monitoring.
3. Analyzed and formatted data will be classified.
4. Raw electronically recorded data (in digital form) will be unclassified.
5. Raw manually recorded data and narratives may be classified.

6. Quick-Look data may be classified.

Based on these assumptions, certain requirements for the DMS (particularly on the operations and equipment) are evident, including:

1. Use of commercial computational or storage facilities, such as Computer Sciences Corporation's (CSC) INFONET System may be severely limited.
2. Field test site analysis areas must be secure.
3. Secure data communications lines from a test site to the main computer facility for the program may be required for long term tests or high priority tests.
4. Data processing and storage systems must be secure. This implies that possible Government computer systems (such as AFWL's CDC 6600) may not be used due to insufficient availability for classified processing time.
5. Data base storage facilities/library must be secure.

These assumptions and associated requirements are being considered in the development of the DMS, DMP. They also provide some basic guidelines for defining DMS hardware requirements.

3-4.4 DMS Hardware Requirements.

Studies have been initiated to define the optimum hardware requirements for the DMS. Initial trade-off assessments have addressed computer size, type, location, access and use requirements, and cost. The basic criteria used to evaluate these systems consisted of:

1. Capacity. The system must be able to handle large amounts of data for both the DMS and the support of computer analysis routines.
2. Responsiveness. The system must provide reasonable turn-around time for data analysis.
3. Security. The system must have provisions for processing and storing classified information and limit access to the data base.

4. Cost. Ideally the system should be low cost and able to expand, if necessary, without major cost impacts.
5. Compatibility. The system must be compatible with existing analysis software and with the basic TNF S² instrumentation system without requiring extensive software modifications.
6. Flexibility. The system must be flexible enough to handle growth, additional data and analysis requirements, and be continuously available.

The systems investigated during this study included both commercially-owned and Government-owned major computer centers which house a main frame computer system (e.g., CDC 6600, UNIVAC 1108) and some of the currently available minicomputer systems. The main frame computer systems, both commercially and Government owned, posed several immediate disadvantages. First and foremost, neither system can effectively handle large amounts of classified information. The commercial systems, such as Computer Science Corporation (CSC) INFONET System, cannot handle any classified information. Government owned systems, such as AFWL's CDC 6600 system, can handle classified information only during certain time periods. Second, both centers have very slow response time on both batch and interactive processing due to the large number of users. Third, both centers exhibit slow output turnaround times. Finally, the cost of using these centers is high. For use of the commercial center the minimum cost is \$1500.00 per CPU (Central Processor Unit) hour. On an average, approximately 3 CPU hours per week would be required for a program such as the TNF S² program. This would amount to a basic cost of \$234,000.00 per year. This cost does not include such things as data storage space rental, use of software routines, or system usage (which currently, on low priority tasks, costs 3 cents per minute). Use of a Government center, on industrial funding, costs about the same (\$1200 to \$1500 per CPU hour), which equates to \$187,200 to \$234,000 per year. Neither of these yearly cost estimates includes rental or purchase of remote terminals or supplies.

The minicomputer systems evaluated included off-the-shelf systems available from Texas Instruments (TI), Hewlett-Packard (HP), IBM, and NOVA. The most logical choice is the system planned for the TNF S² instrumentation development program. The system described in Reference 22 is based on a TI 990/10 minicomputer. With additional memory and peripherals, this system will satisfy the requirements for the DMS. Cost of additional equipment and software to support data management and data analysis is in the range of \$100,000. Even if additional memory or peripherals are required in the future, the cost is considerably less than large computer rental. The advantages of using this system (TI990/10) for the DMS include:

1. Compatibility. The system used to program the instrumentation system will be the same system used to process data from the instrumentation system.
2. Less Software Interfacing. The instrumentation programming and data processing systems will effectively be the same which will prevent excessive software requirements.
3. Security. The instrumentation system and DMS peripherals will be co-located in a secure, controlled access area.
4. Quick Response. The system, totally dedicated to the TNF S² program, will be available continuously.
5. Cost Effective. Peripherals necessary to add DMS capability to the instrumentation development system will cost approximately \$100,000. This is essentially a one-time cost for the entire program.
6. Capacity. The system can accommodate 10-12 users without system slowdown or saturation. Remote terminals to support field testing can be added without exceeding system capabilities.

It is highly recommended that the capabilities of the instrumentation development minicomputer system be expanded to handle the DMS and data analysis tasks for the reasons listed above. Table 2 presents a comparison of cost for large computer center rental versus the TI 990/10 system.

Table 2. Computer cost comparison for DMS hardware (dollars).

SYSTEM INVESTIGATED	COST PER YEAR	TOTAL COST THROUGH FY83	REMARKS
COMMERCIAL CENTER	234,000	1,170,000	DOES NOT INCLUDE STORAGE, SOFTWARE, TERMINAL RENTAL COSTS.
GOVERNMENT CENTER (INDUSTRIAL FUNDING)	187,200 TO 234,000	936,000 TO 1,170,000	DOES NOT INCLUDE TERMINAL RENTAL COSTS, SYSTEM USAGE.
GOVERNMENT CENTER (GOVERNMENT PROVIDED)	31,200 TO 128,700	156,000 TO 643,500	CDC 6600/CYBER 176 SYSTEMS. NO REMOTE CAPABILITY, SLOW RESPONSE ON CLASSIFIED DATA PROCESSING. COST DOES NOT INCLUDE SYSTEM USAGE.
TI 990/10	-	100,000 APPROX.	ONE-TIME COST OUTLAY. MAY REQUIRE ADDITIONAL PERIPHERALS. (COST INCLUDES ONLY REQUIRED DMS PERIPHERALS)

3-5 TEST/EXERCISE FACILITIES.

3-5.1 General.

Existing test and exercise facilities were surveyed to determine their capability to support TNF S² tests and evaluations. The survey was based on generic issues, and therefore the results presented in the following paragraphs apply to general program requirements. As test specific IEP's are developed, the facility requirements will be detailed. The main thrust in this survey was to determine if a dedicated facility was required for the TNF S² program. Based on the information obtained to date, a dedicated TNF S² range facility equivalent, for example, to CDEC is not required. The TNF S² program, however, can use these national assets and support unique TNF S² requirements by using the advanced instrumentation system now under development as part of the TNF S² program. There are areas within the TNF S² program, however, for which a dedicated facility may be desirable. For example, physical security improvements for nuclear storage, characterized by installation and testing of many iterations and combinations of prototype physical security systems, could require dedicated facilities for a multi-year period. As presently envisioned, a facility of this nature would make maximum use of existing storage areas available and unused on several military bases. Further investigation will determine which site would be optimum for these kinds of tests.

3-5.2 Discussion.

The basic criteria used in evaluating existing test/exercise facilities for projected TNF S² needs is presented in Figure 10. The evaluation elements and characteristics of this matrix were used as a checklist for all facilities surveyed. Facility information for the various ranges was obtained from existing range documentation (References 23, 24, and 25). It was considered premature to approach range personnel for more detailed information concerning schedule, availability, etc. without preliminary test specifics. The evaluation matrix shown in Figure 10 was used to develop the summary results matrix in Table 3

TEST/EXERCISE SITE EVALUATION - PRELIMINARY STUDY

EVALUATION ELEMENTS - CHARACTERISTICS

TEST/EXERCISE SITE EVALUATION - PRELIMINARY STUDY	EVALUATION ELEMENTS - CHARACTERISTICS		TEST SUPPORT		RANGE USE COORDINATION REQUIREMENTS		CURRENT TEST/EXERCISES		REMARKS								
	INSTRUMENTATION CAPABILITY	DATA REDUCTION CAPABILITY	DATA REDUCTION CAPABILITY	TEST SUPPORT	TEST SUPPORT	RANGE USE COORDINATION REQUIREMENTS	RANGE USE COORDINATION REQUIREMENTS	CURRENT TEST/EXERCISES									
RANGE	LOCATION	SIZE	TERRAIN	PLACED/RESI	RCA	EVENT ANNOTATION	RECORDS/RELAYS	EQUIPMENT	OT FACILITIES	RANGE AVAILABLE AREAS	CONTROL REQUIREMENTS	APPROVAL TIME	SECURITY CAPABILITY	RESTRICTION	CURRENT TEST/EXERCISES	COST/UNDING	PROJECTED PROGRAMS
FHL																	
FT. HOOD																	
NELLS RED FLAG																	
NELLS ACMI																	
TONAPAH																	
FT. HUACHUCA																	
FT. SILL																	
FT. BRAGG																	
EGLIN AFB																	
FT. BENNING																	
GERMANY																	

Figure 10. Test/exercise site evaluation matrix.

Table 3. Facilities summary.

Facility	Location	Inventory	Condition	Inspection	Remarks	Disposition	Quality of Work
500-400
Water Line
500-410
Port Building
Bank Deposits
500-420
500-430
500-440
500-450
500-460
500-470
500-480
500-490
500-500

7

which presents the results of the primary ranges/facilities under consideration for the TNF S² program. Table 3 presents a summary of some facilities and their capabilities for TNF S² test support. The facilities listed represent those considered most appropriate for supporting the TNF S² program. Detailed descriptions of some of the candidate military facilities are presented in Appendix C.

It was necessary to make some basic assumptions concerning the program progression and anticipated requirements to substantiate the need for a dedicated facility. These primary assumptions are:

1. A dedicated, stand alone portable instrumentation system for the TNF S² program will be available late FY80.
2. Rigorous testing will be conducted in a build-up manner. For example, security testing of an Army TNF element would involve (in chronological order):
 - a. Collection of qualitative baseline information by physical monitoring of Army Military Police (MP) training exercises to determine procedures, training, equipment, constraints, etc. which would affect the design of the test.
 - b. Detailed planning activities would commence after analysis of the baseline information.
 - c. Test execution would be conducted in a set sequence beginning with a period of player training and practice. This would be followed by the scenario trials for record data and would culminate in the final analysis of the test results.
 - d. Verification of CONUS results and evaluation in a European environment.
3. Testing in Europe will consist of spot checks to insure results obtained in the CONUS are valid in Europe. European evaluations would consist of monitoring exercises which will include, as a part of the exercise, improvements previously verified in the CONUS.

Based on these assumptions, the Program Management Plan and the EUCOM issue responses, initial program activity will consist primarily of monitor efforts, adjunctive tests, and studies. The primary facilities consideration for early efforts is to locate with the affected units. For example, monitor efforts and adjunctive tests concerning Field Artillery could be accomplished at Fort Sill, Oklahoma. Site Security information, as another example, could initially be obtained by monitoring training activities at Ft. McClellan (Army MP training) or Camp Bullis (Air Force SP training), both sites have mock ups of weapon storage facilities. Further and more detailed information could then be obtained by adjunctive tests or small scale tests at the Redstone Arsenal, the location of an actual storage site currently not being used. Some facility/range modification or engineering may be necessary to adapt specific test areas to TNF S² unique tests. The early instrumentation system for the TNF S² program will be based on LORAN C and therefore would limit test area in the mid to late FY80 time frame to the areas shaded in Figure 11. With a dedicated instrumentation system, available in FY81, primary facility requirements such as a range, TDY facilities, etc. would be available at most military installations such as Camp Drum, New York and Ft. Lewis, Washington. Rigorous large scale tests would require intensive planning and coordinating activities. By the time these tests are ready to be executed, a dedicated instrumentation system should be available.

There are programs within the purview at the TNF S² program for which a dedicated test facility may be highly desirable. These programs, notably the physical security and communications upgrade efforts, are currently oriented toward development and equipment/systems optimization. Range requirements for these programs are relatively constant and long term with testing or evaluations of several iterations and combinations of prototype equipment/installations on a continual basis. Development of dedicated facilities to support, for example, physical security of nuclear weapons storage sites, would make maximum use of existing and unused CONUS storage sites on military bases such as

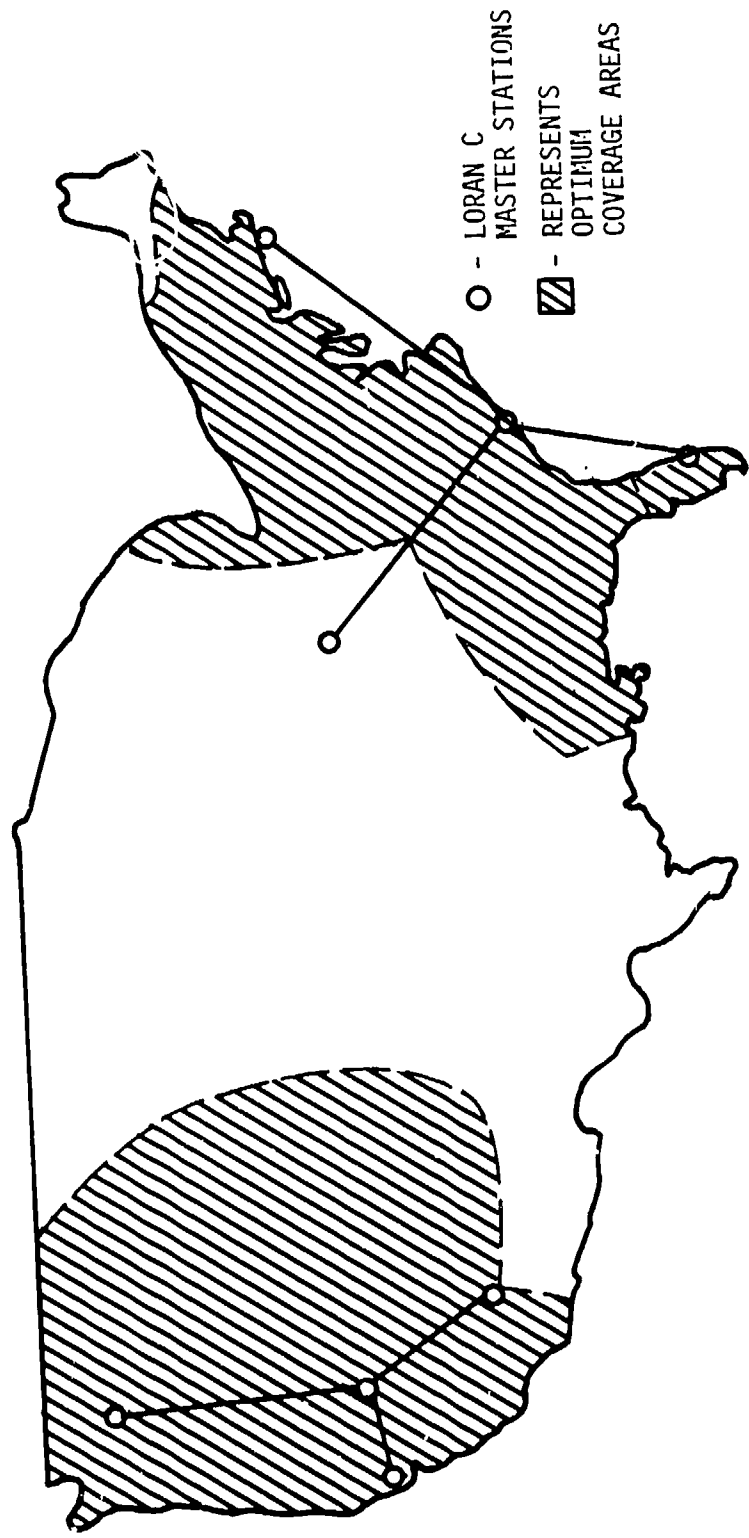

Figure 11. LORAN C coverage within CONUS.

the Redstone Arsenal. The establishment of such a facility would provide the necessary resources for installation and testing of many iterations and combinations of prototype physical security systems and also provide for the operational testing of candidate systems through instrumented force-on-force tests. Additionally, other TNF S² tests could conceivably be accomplished at a facility of this nature, including storage site load-outs, convoy movements, etc. Further investigations will determine the optimum sites for programs of this type.

3.5.3 Summary.

Dedicated TNF S² test facilities equivalent to a CDEC facility does not appear required. A majority of envisioned TNF S² tests could be conducted on existing Government facilities, especially with the availability of the dedicated TNF S² instrumentation system. Dedicated facilities for some programs under the purview of the TNF S² program, notably physical security, may be highly desirable due to their continuing nature. A facility of this nature would make maximum use of existing Government facilities.

SECTION 4
CONCLUSIONS AND RECOMMENDATIONS

The following are the conclusions and recommendations derived from the TNF S² Early Test Capability Development program:

1. The TNF S² Early Test Capability Development program was based on the total generic issues list and not specific issues. The results, therefore, are tuned to overall program concepts and methodologies.
2. Test and evaluation planning documentation must be structured to allow for effective management and tracking of issue status.
3. The IEP developed for preliminary USAFE issues provides the preliminary format which may be used as a standard for all IEP's.
4. The TNF service issues are sufficiently inter- and intra-related such that tests, evaluation, and analyses of the issues must be performed in an integrated fashion.
5. The methodology used to plan and evaluate TNF S² enhancement options must be able to assess the combined responses of operational readiness, survivability, security, availability, and force effectiveness.
6. The TNF-OP provides a methodology for characterizing the TNF elements with respect to development of analytical treatment techniques.
7. The need for monitoring and adjunctive testing is reaffirmed. In addition to partially addressing specific issues, monitoring or participation in training exercises would provide early information for the development of a TNF operational data base.
8. Monitoring of selected training exercises in the CONUS (e.g., Security force training at Ft. McClellan and Camp

Bullis, III Corps artillery exercises at Ft. Sill, etc.) should be initiated as soon as possible to continue development of an operational data base and provide a liaison between organizations.

9. Development of the TNF S² Data Management System must be continued in order to provide the vehicle for documentation, control, and the central repository for all TNF S² generated information.
10. Data requirements definition for the total program is an evolutionary task which must be continued to develop the TNF S² Data Management System.
11. The capabilities of the instrumentation development computer system (TI 990/10) should be expanded to support the requirements of the DMS and computer analysis.
12. A dedicated TNF S² range facility equivalent, for example, to CDEC does not appear justified.
13. A majority of currently envisioned tests can be conducted on existing Government facilities/ranges.
14. Range development may be desirable for specific TNF S² areas such as physical security testing which requires relatively long term facilities.

SECTION 5

REFERENCES

1. Development of Scope for Improving the Survivability and Security of the Theater Nuclear Force, The BDM Corporation. UNPUBLISHED
2. Draft Final Report on Security and Survivability of TNF Logistics Support Capabilities, JAYCOR. UNPUBLISHED
3. "USAFE TNFS² INITIATIVES." UNPUBLISHED
4. Theater Nuclear Force Survivability and Security Measures of Effectiveness, The BDM Corporation, BDM/W-78-664-TR, 30 November 1978.
5. Box, George E. P. and Norman R. Draper. Evolutionary Operation, John Wiley & Sons, Inc., New York, New York, 1969.
6. Cochran, William G. and Gertrude M. Cox. Experimental Designs, (2nd Ed.) John Wiley & Sons, Inc., New York, New York, 1957.
7. Sukhatme, P. V. and B. V. Sukhatme. Sampling Theory of Surveys with Applications, Iowa State University Press, Ames, Iowa, 1970.
8. Bishop, Yvonne M. M., S. E. Fienberg, and P. W. Holland. Discrete Multivariate Analysis: Theory and Practice, The MIT Press, Cambridge, Massachusetts, 1975.
9. Blackwell, David and M. A. Girshick. Theory of Games and Statistical Decisions, John Wiley & Sons, New York, New York, 1954.
10. Gnanadesikan, R. Methods for Statistical Data Analysis of Multivariate Observations, John Wiley & Sons, Inc., New York, New York, 1977.
11. Keeney, Ralph L. and H. Raiffa. Decisions with Multiple Objectives, John Wiley & Sons, New York, New York, 1976.
12. Tukey, John W. Exploratory Data Analysis, Addison-Wesley Publishing Co., Reading, Massachusetts, 1977.
13. Feller, William. An Introduction to Probability Theory and its Application, Vol I (3rd Ed.) and Vol. II (2nd Ed.), John Wiley & Sons, Inc., New York, New York 1968 and 1971.

14. Howard, Ronald A. Dynamic Programming and Markov Processes, The MIT Press, Cambridge, Massachusetts, 1960.
15. Nemhauser, George L. Introduction to Dynamic Programming, John Wiley & Sons, Inc., New York, New York, 1966.
16. Meisel, William S. Computer-Oriented Approaches to Pattern Recognition, Academic Press, New York, New York, 1972.
17. Polya, G. Patterns of Plausible Inference, Princeton University Press, Princeton, New Jersey, 1954.
18. Churchman, C. West. The Systems Approach, Dell Publishing Co., New York, New York, 1968.
19. Iberall, Arthur S. Toward a General Science of Viable Systems, McGraw-Hill Book Co., New York, New York, 1972.
20. Jantsch, Erich. Technological Forecasting in Perspective, Organization for Economic Co-operation and Development (OCED), 1967.
21. Zadeh, L. A. "Fuzzy Sets as a Basis for a Theory of Possibility," Fuzzy Sets and Systems, Vol. 1 (1), 1978, pp 3-28.
22. Final Report - TNFS² Instrumentation Development (Draft), The BDM Corporation, BDM/TAC-78-490-TR, October 1978.
23. Operational Test Instrumentation Guide Vol. I, II, and III, The BDM Corporation and RMC Research Corporation, January 1974.
24. Department of the Army Five Year Test Program - User Tests, (FY 1978 - 1984).
25. DARCOM Test Facilities Register. DARCOM Pamphlet 70-1.
26. Dictionary of Military and Associated Terms, Department of Defense, The Joint Chiefs of Staff, Washington, D. C., 3 September 1974.
27. Fire Support in Combined Arms Operations, Headquarters, Department of the Army Field Manual No. 6-20, 30 September 1977.

APPENDIX A
CONCEPTS FOR THE PRELIMINARY DATA MANAGEMENT PLAN

8
A-1 INTRODUCTION.

The Preliminary Data Management Plan provides for the control of test data from the point of raw data acquisition through the incorporation of test results in the report. During the preliminary stages of the TNF S² program, the Data Management Plan is generic in form and content.

The detailed Data Management Plan will be implemented through the development of a series of sections which describe in detail all of the requirements, activities, and procedures and list the required skills necessary to the successful implementation of data management. These sections consist of:

1. Data Acquisition
2. Data Collection
3. Data Reduction/Processing
4. Data Base Management
5. Quality Control
6. Quick-Look Analysis

A-2 DATA ACQUISITION.

A-2.1 Purpose.

The purpose of the data acquisition section is to identify the data requirements necessary to support the analytical assessment of the TNF S² program. The data requirements are consolidated and listed by measurand. These listings contain the measurand, abbreviated description, applicable force (or threat), and disposition of the data. It also identifies where and how the data are to be collected.

A-2.2 General.

The data acquisition section identifies each data element required to:

1. Support analysis.
2. Structure a data base management system to support analysis.

3. Identify the source.
4. Describe the data source and procedures for recording information.

A-2.3 Data Requirements.

The data requirements necessary to support TNF S² analytical assessment are in the form of quick-look data and detailed summary data. An example of a preliminary Data Requirement List (DRL), which is TNF S² peculiar, is identified in Table A-1. As test planning and design progresses, the DRL will be modified as necessary. The DRL will be automated to provide a responsive and economical method for making changes in the listings, adding or deleting measurands, preventing duplication, identifying requirements for measurands which do not presently exist, and listing by line item to verify measurands in detail.

A-3 DATA COLLECTION.

A-3.1 Purpose.

The purpose of the data collection section is to bridge the gap between the acquisition of the data and the reduction and processing of the data. The plan will provide a comprehensive guide on the procedures to be followed for collecting data from either data collectors or instrumentation system and for delivering to a data collection center for processing.

A-3.2 General.

The data collection section identifies the source of data, where the source data is located, the guidelines for collecting and handling the data, the schedule and frequency for data collection, and provide proposed forms for manually recording data.

A-3.3 Proposed Raw Data Sources.

1. Digital Data. Digital data which deal with individual participants are recorded on a manpack processor system that will provide the integrated functions of data logging, real-time annotation, kill/hit determination, and position location interpretation.

Table A-1. Preliminary Data Requirements List.

DATA MEASURAND	THREAT		DATA CLASS		DATA COLLECTION POINT			DATA SOURCE														
	AIR	GROUND	NONE (FRIENDLY)	HISTORICAL	OUTCOME	SUPPORTIVE	PREVIOUS TEST	BRIEFINGS	ACQUISITION	ATTACK	ALTHORNAAL	DEBRIEFING	EXEC.	POSTTEST	INSTRUMENTATION	DEBRIEFING	PLAYER	ENVIRONMENTAL	CRITICAL EVENT	HUMAN FACTORS	TRAINING	
																						PRETEST
TEST DESIGNATION																						
LOCATION																						
DATE																						
START TIME																						
STOP TIME																						
PLAYER ID																						
TARGET ID																						
WEAPON ID																						
POSITION DATA																						
POSTURE																						
MARKSMANSHIP																						
FIRING MODE																						
ROUND TYPE																						
ROUND NUMBER																						
TARGET POSTURE																						
RANGE TO TARGET																						
FIRST TARGET FIRE																						
FIRST PLAYER FIRE																						
FIRST PLAYER KILL																						
FIRST TARGET KILL																						
PLAYER ROUNDS FIRED																						
TARGET ROUNDS FIRED																						
TAUS (SENSOR)																						
TIME FIRST ROUND FIRED																						
TIME FIRST KILL																						
TIME SUBSEQUENT KILLS																						
DISTANCE FIRST DEF.																						
DISTANCE FIRST SHOT																						
DISTANCE FIRST KILL																						
DISTANCE SUBSEQUENT KILLS																						
TYPE OF TARGET																						
TOTAL PLAYER SHOTS																						
TOTAL PLAYER KILLS																						
VISIBILITY																						
GROUND TEMPERATURE																						
TERRAIN																						
WEATHER																						
IDF WEAPON TYPE																						
IDF ATTACKER ID																						
IDF TARGET ID																						
TYPE OF IDF																						
AREA COVERAGE IDF																						
IDF TIME OF FLIGHT																						
IDF NON-LOS																						

2. Environment Data. Weather data will be recorded and acquired from air weather service or mobile meteorological stations prior to testing.
3. Audio/Visual. A/V data will be acquired from the TV/Audio van.
4. Briefing Data. Participant debriefing data will be acquired by debriefing the participants immediately following each test.

A-4 DATA REDUCTION/PROCESSING.

A-4.1 Purpose.

The purpose of the data processing section is to provide the guidance and procedures to be used in the reduction and processing of TNF S² program data.

A-4.2 General.

The data reduction function encompasses the translation of raw data into a more structured readable format suitable for aggregation in a single medium. Thus, manually collected data and key data derived from automatic and photographic data sources will be prepared for computer processing. A minicomputer system could be used for the data processing function. Necessary computer software will be implemented as necessary to meet the demand of each test.

A-4.3 Data Management Organization.

The data management organization (DMO) will be managed by a Data Processing Manager who will have overall administrative and technical responsibility. The Data Operations and Data Base Administrators will report directly to the Data Processing Manager.

The data operations administrator will be responsible for developing and implementing job processing schedules, maintaining program and tape library facilities, and scheduling data collectors operations. The following skills will support the Operations Administrator:

1. Librarians
2. Control Clerks

3. Data Collectors
4. Computer Operator

The Data Base Administrator will be responsible for all software and analysis related to the operating software system, the data base, and the data collection and reduction process. The following skills will support the DBA:

1. System Programmers
2. Application Programmers
3. Scientific Programmers
4. Data Base Programmers
5. Data Clerks

A-4.4 Data Processing Concept.

The overall data processing concept can be divided into three major flows:

1. Manual File Creation Flow
2. Quick-Look Flow
3. Data Base Flow

The manual file creation flow is shown in Figure A-1. Manual data will be entered via cathode ray tube (CRT) directly to the computer. Data collection forms will be generated to aid in collecting the information necessary to meet the requirements for quick-look analysis. All data files will be saved according to the source and recorded on tape for backup.

The quick-look flow is shown in Figure A-2. The event, digital file, and other file will be processed to generate a quick-look analysis package that would contain the following files:

1. Statistical File
2. Processed Event File
3. Temporary Data Base File
4. Other

These files will be processed by a series of software packages which will generate reports and plots. Upon completion of each test, three 9-track tapes will be generated. Both the transaction backup tape and the data

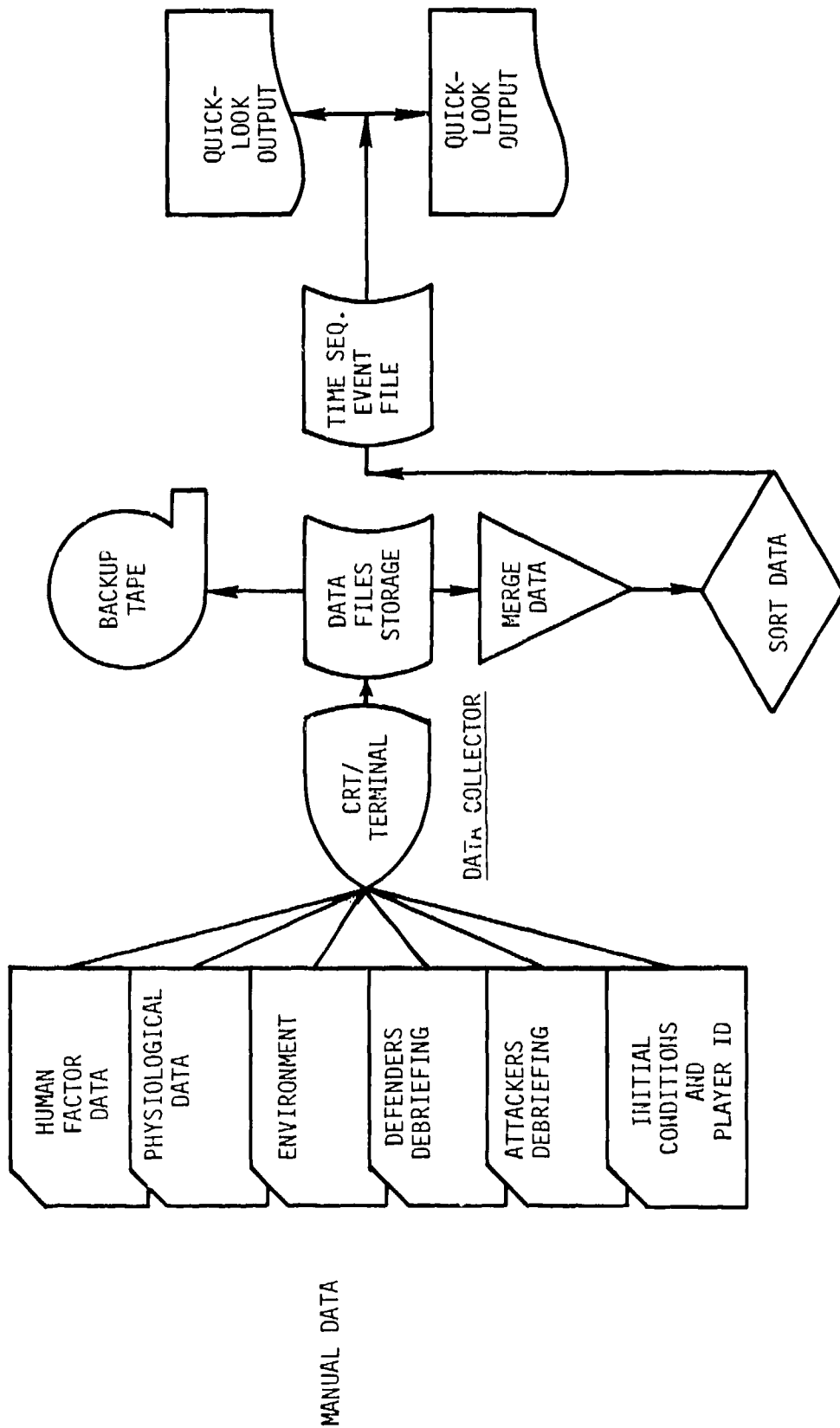

Figure A-1. Manual file creation flow.

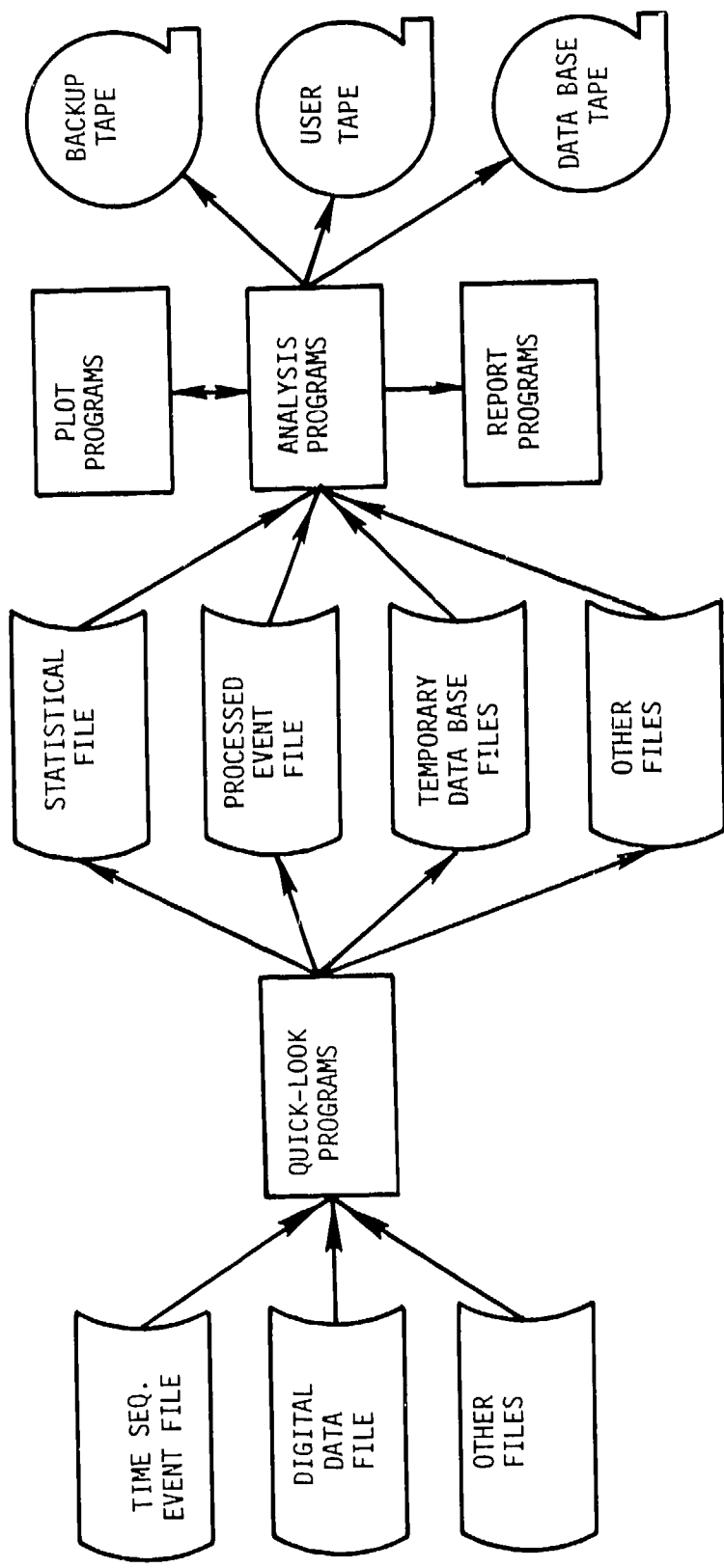

Figure A-2. Quick-look flow.

base tape will be stored in a protected area. The third will be delivered to the user, if required, for further analysis.

The data base flow is shown in Figure A-3. When all of the files have been processed for a test, the data base will be updated using the data base file output. A data base model update program will do the update, output the status of the data base, and generate a backup tape.

The data base will always have a magnetic tape duplicate. Both the update tape backup and the master data base backup tape will be stored in a protected area. If required, these tapes would be used to restore the data base.

To insure security, storage, and retrievability of test data, control personnel will establish procedures and monitor the methods for handling data at the storage facility. A library will be established to serve as the repository for all documents, manual data forms, computer listings, tapes, and film collected during any test or evaluation. The library will operate on a daily schedule, staffed by persons capable of safeguarding the filing integrity of the system. The library will have:

1. Methods of filing to insure the retrievability of all data.
2. Library users who are cleared for access, required to sign out data, and accountable for data signed out to them.
3. A secure, fireproof safe for the protection of critical records.

A-5 DATA BASE MANAGEMENT.

A-5.1 Purpose.

The purpose of the data base management (DBM) section is to file, in a logical manner, records or elements of many types, to provide a direct and immediate access from the storage media for analysis and quick-look information.

A-5.2 General.

The Data Base Management will accept as input all elements for inclusion to the data base. The DBM system (DBMS) will maintain a comprehensive end user facility designed to provide quick reaction capability

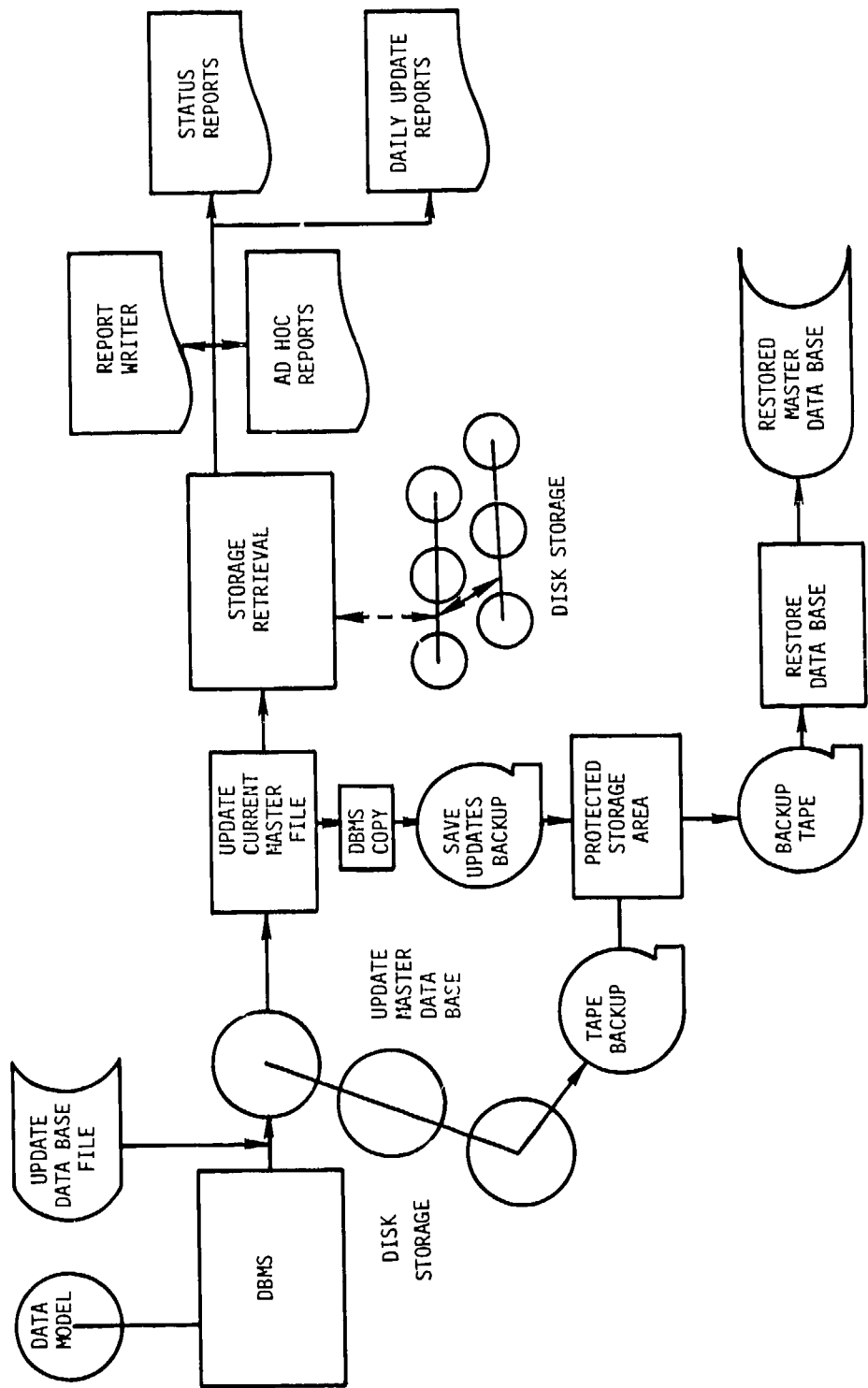

Figure A-3. Data base flow.

in satisfying the ad hoc, unplanned, spontaneous needs for information storage and retrieval.

A-5.3 Data Base Capabilities.

A comprehensive generalized DBMS with full inversion of selected elements must in fact meet the following criteria:

1. DBMS must support multiple host languages (i.e., FORTRAN, COBOL).
2. DBMS must have a variety of flexible data structures (i.e., network, tree).
3. DBMS must offer advanced recovery and concurrent access.
4. DBMS must support large data base storage.
5. DBMS must provide privacy/security features.
6. DBMS must provide immediate access and batch mode capabilities.

A-5.4 Report Writer Feature.

The DBMS should include report writer capabilities that will provide the customer with a method of obtaining an interim test report. Report writer will extract the MOE's or any other element from the data base and provide a status report in a standardized format.

A-5.5 Data Base Structure.

The data base structure is shown in Figure A-4.

A-6 QUALITY CONTROL.

A-6.1 Purpose.

The purpose of the quality control (QC) is to eliminate or reduce the uncertainties in the qualitative and quantitative data obtained by each test, and provide a process of insuring acceptability of each issue from each test. The primary objectives of the QC are:

1. To insure that each test data set meets the criteria required by the experimental design and is comparable within each test condition.
2. To provide for the prevention and ready detection of discrepancies and for the initiation of timely and responsive corrective action.

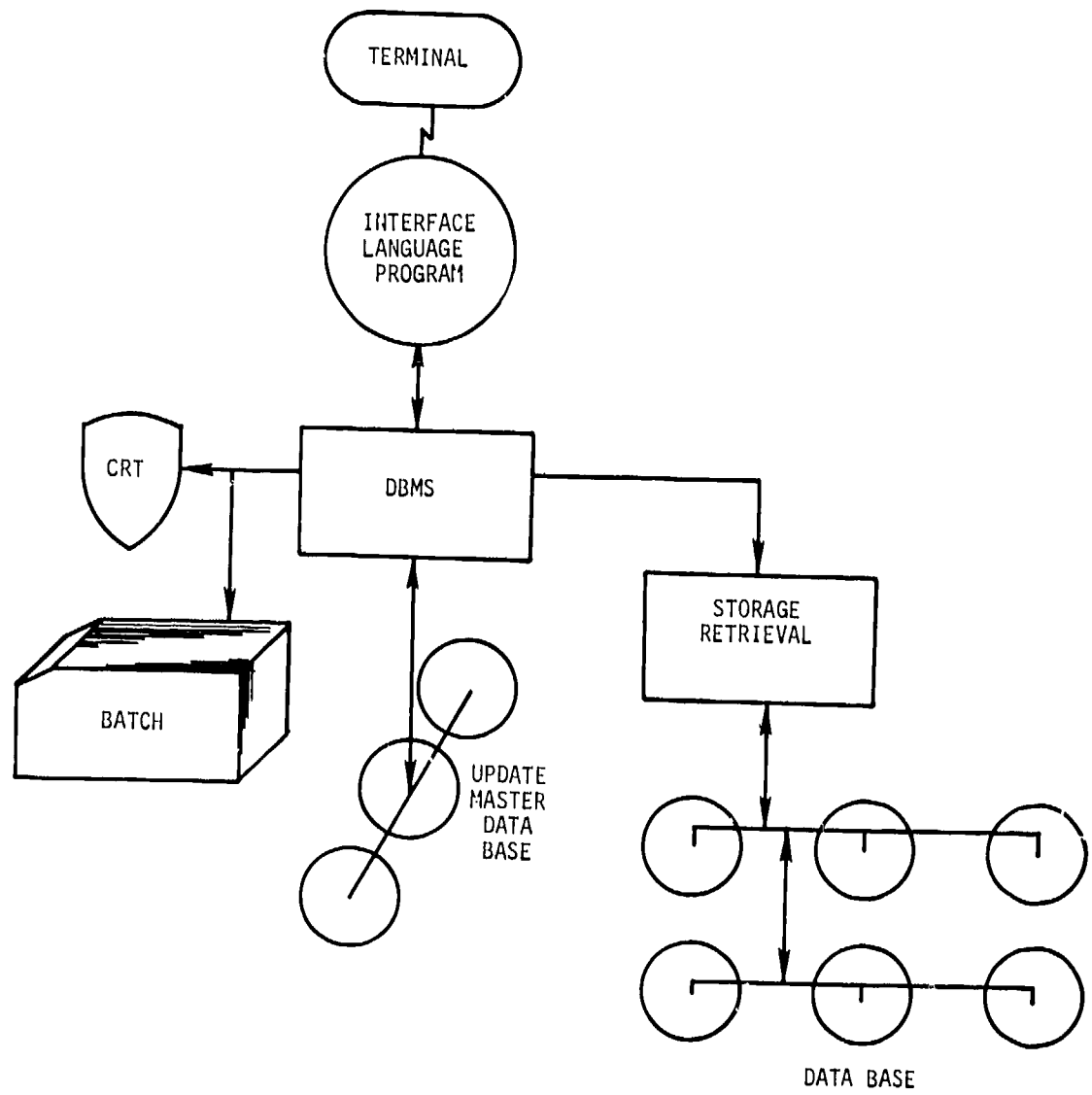

Figure A-4. Data base structure.

3. To identify malfunctions and record sufficient data where experimental design standards have not been met, in order to provide immediate feedback for corrective action.
4. To establish comprehensive quality control procedures and techniques that will enable preliminary and final determination regarding the validity of a test.

A-6.2 General.

QC should be initiated into three phases of the field test cycle:

1. Pretest and Validation
2. Test Execution and Data Acquisition
3. Posttest Data Collection, Reduction, and Analysis Phases

When developed, this section will establish the control organization and the functional tasks of QC personnel for each major activity, outlines the test acceptance criteria required for QC, and provides for the documentation, transmittal, and storage of trial data.

A-7 QUICK-LOOK ANALYSIS.

A-7.1 Purpose.

The quick-look analysis section is designed to provide a basis for defining data requirements, data flow, data quality control checks, test validation procedures, and input/output requirements necessary to meet quick-look objectives.

A-7.2 General.

In general, the quick-look analysis system is structured to provide, within a 24-hour time frame, three types of information: test validity data, test status data, and trend analysis information. The test validity data process identifies those tests which have met all criteria for inclusion in the test data base. Concurrently, the system will produce printouts indicating those missing data elements in each test. Test status information discloses data describing the number of scheduled tests that are effective and, in general, how the overall program is progressing in terms of meeting test requirements and providing system status reports. Trend analysis information, on the other hand,

provides data indicating how each of the systems being tested is currently performing. Specifically, quick-look objectives are delineated as providing data quality processing, test validation processing, data reduction/processing for quick-look analysis, and quick-look outputs. The quick-look system flowchart is shown in Figure A-5.

A-7.3 Data Quality Processing.

Data quality processing will consist of software procedures to insure that for each test, all sources of data are complete, all data forms are complete, the continuous digital data tape is suitable for replay, and there is agreement among all data sources.

A-7.3.1 Completeness of Data Forms. For each test, software programs will be developed to determine if all data sources are present. That is, data input has been processed and a disk file generated which will contain:

1. Environmental Data
2. Test Data
3. Detection Data
4. Identification Data
5. Weapon Firing Data
6. Kill Data
7. Video Data
8. Test Termination Data
9. Instrumentation Status Data

Missing data sources will be listed and corrected prior to commencing final processing.

The data quality software will scan each file to determine the validation of all data collected and to insure that:

1. All data elements are present (not blank).
2. Numeric data are numeric.
3. Events occur sequentially for each activity.

A-7.3.2 Quick-Look Analysis. Quick-Look Analysis program will exist to further assist the analysts in determining test validity. The analysis programs will include:

1. Player Positional Advantage Analysis
2. Event Analysis
3. Statistical Analysis

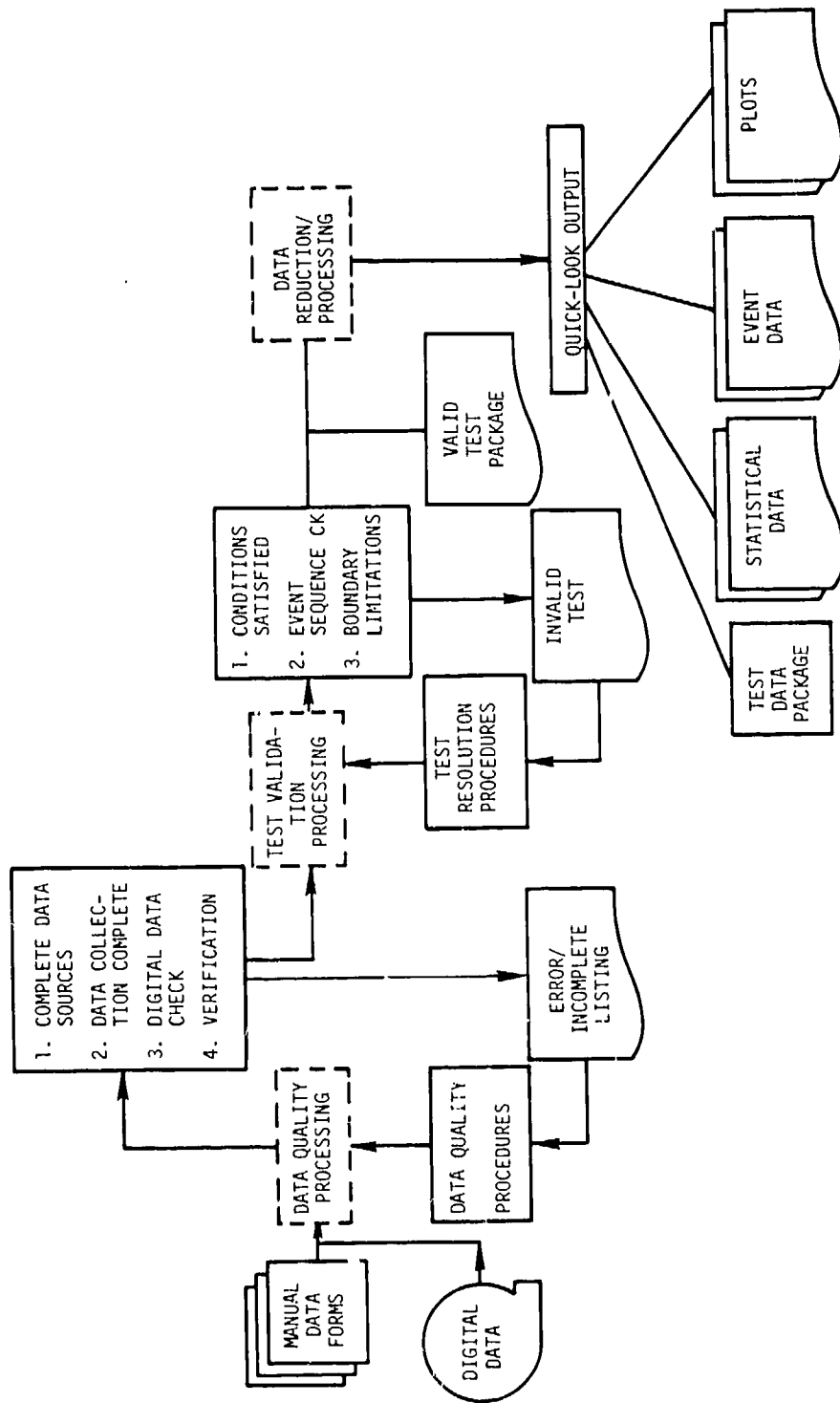

Figure A-5. Quick-Look system.

A-7.3.3 Player Positional Advantage Analysis. This analysis software will assist the analyst in determining positional advantage.

This software will determine the time of each player's change of position with respect to all targets.

The data elements generated for player positional advantage will then be passed to the event analysis package for further processing.

A-7.3.4 Event Analysis. This analysis package will allow the analyst to establish the validity of events as they relate to previous and subsequent events. The package processes all events for a single test. These events include display of time and other related data elements for the following:

1. Test Start
2. Detection
3. Identification
4. Weapon Selection
5. Positional Advantage
6. Posture
7. Location
8. Kill or Miss Notification
9. Test Termination

By using these times and the related data elements, the analyst should be able to objectively determine test validity.

A-7.3.5 Statistical Analysis. These software packages will perform predefined statistical manipulations and computer analysis using data collected by the event analysis file. Graphs and printed output will be prepared summarizing these statistics for each event.

A-7.4 Quick-Look Outputs.

Quick-look outputs will consist of computer listings, summaries, and graphics; they will provide a means for evaluating test status reports, how well the test is progressing, and trend analyses (how well the systems being tested are performing).

A-7.4.1 Detailed Data Package. The objectives of the detailed data package are:

1. A single format magnetic tape and/or listing to be distributed to all concerned agencies.
2. To begin distribution of the package within 24 hours of the end of a test.

A-8 COMPUTER CONFIGURATION DESCRIPTION.

Texas Instrument DS 990/10 minicomputer will be used for all TNF S² data management processing tasks. The TI 990/10 will operate under a DX10 disk based operating system which is especially designed for interactive, multiuser, multitasking operations. The TI DS 990/10 will be equipped with dual 50 M-BYTE disk base system for large scale software development and data base management.

The TI DS 990/10 will allow maximum flexibility in adding optional software and hardware features to the main computer system.

The following is a description of additional hardware and software inherent on the TI DS 990/10:

HARDWARE	DS50 SECONDARY KIT 979A MASTER KIT EC EXPANSION MEMORY MODEL 911 VDT EXPANSION DISPLAY AND KEYBOARD MODEL 911 VDT 1920 CHARA. DUAL CONTROLLER, 2 DISPLAYS AND KEYBOARD HOUSTON INSTRUMENTS PRINTER ELECTROSTATIC PLOTTER
SOFTWARE	DX-10 FORTRAN LICENSE PASCAL LICENSE DX-10 COBOL LICENSE DX-10 SORT/MERGE LICENSE DX-10 BASIC LICENSE 990 DIAGNOSTICS RPG-II LICENSE DX-3780 EMULATOR LICENSE

APPENDIX B
TNF OPERATIONAL PROCESS DESCRIPTION

B-1 GENERAL.

10 The TNF Operational Process (TNF OP) methodology provides for the quantification of the personnel, policies, and machine factors related to TNF S² issues and planned S² enhancements. This appendix contains a detailed discussion of the structure and the activities of the process. An operational example is presented of a 155 mm M109 Self Propelled (SP) Howitzer Battery which is in an advanced state of readiness described by the TNF OP.

B-2 DESCRIPTION OF THE STRUCTURE OF THE TNF OPERATIONAL PROCESS.

The general structure of the TNF OP methodology may be characterized as illustrated in Figure B-1. The following definitions are presented relative to Figure B-1 to illustrate, prior to the detailed discussion of the TNF OP, an operational perspective of the applicability of the TNF OP as a valid methodology from which experimental tests, analysis methodologies, and analysis implementations may be applied to the service issues and areas of concern.

1. Activity. The activity of the process is a description of the functional attribute being addressed (i.e., the location in the process--where we are).
Example: Deployment activities from an assembly area to a general defense position (GDP).
2. Input State. The input state is a description of the process at the beginning of a specific activity.
Example: Assessment of the variables influencing the degree of success of activities performed in the assembly area prior to deployment.
3. State Variables. The state variables of each activity represent the variables which influence the outcome of the activity. They are control variables or concomitant (uncontrollable) variables (covariates).

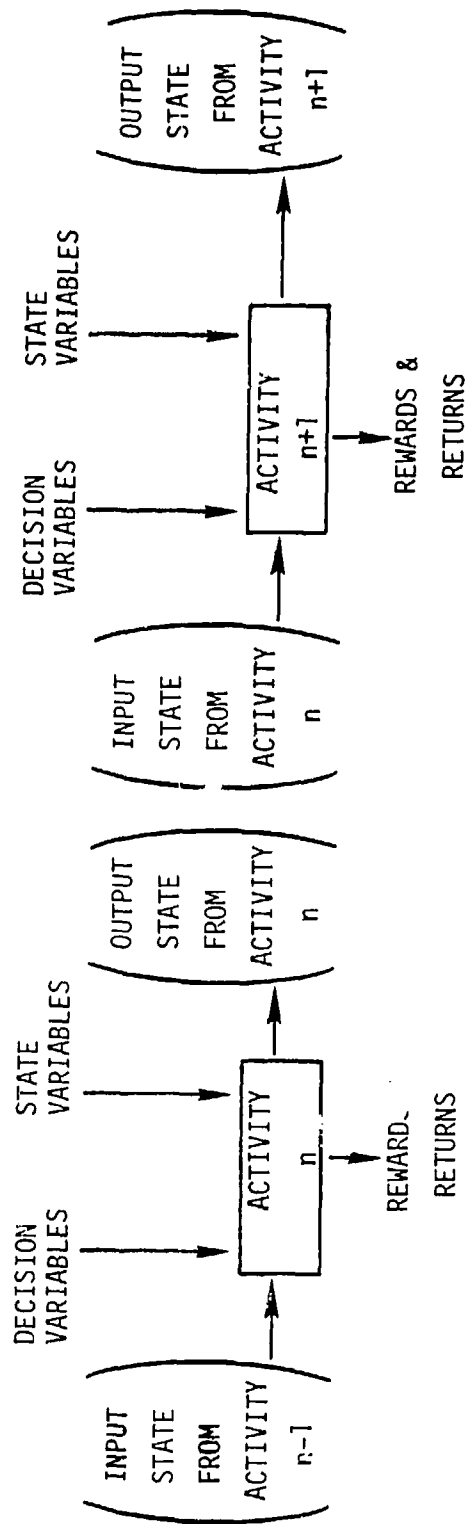

Figure B-1. General structure of two generic functional activities of TNF OP.

Example: Variables influencing deployment activities to the GDP from the assembly area.

4. Decision Variables. The decision variables are levels or categorizations of the state variables.

Example: Variables influencing the degree of success of deployment activities to the GDP.

5. Rewards and Returns. Rewards and returns are measures of the utility of the input state, the state variables, and the decision variables influencing the output of the activity.

Example: Assessment of the degree of success of deployment activities to the GDP.

6. Output State. The output state is a description of the process at the end of a specific activity.

Example: Assessment of the variables influencing the Degree of success of deployment activities to the GDP in order to occupy the GDP.

Using the following notation with respect to Figure B-1,

I_{n-1} = Input from Activity n-1 to Activity n

X_n = State Variables of Activity n

d_n = Decision Variables of Activity n

r_n = Rewards and Returns of Activity n

O_n = Output from Activity n

two conclusions may be drawn:

1. $r_n = f(I_{n-1}, (X_n, d_n), O_n)$
= Rewards and returns response function of Activity n

2. $O_n = t(I_{n-1}, (X_n, d_n))$
= Transfer function of Activity n to Activity n+1

therefore,

$$r_n = g(I_{n-1}, (X_n, d_n), t(I_{n-1}, (X_n, d_n)))$$

= Rewards and returns response function of Activity n as a function of input from Activity n-1, state variables and decision variables of Activity n, and the transfer function of Activity n to Activity n+1

It is emphasized that test and evaluation methodologies driven by the preceding definitions imply that the resultant returns or S^2 enhancements assessed for any one TNF activity are dependent on the returns of connected TNF activities.

This implication is consistent with the requisite demand that TNF S^2 enhancements be assessed in an integrated fashion for the inter- and intrarelated service areas of concern and issues.

The relationships between the preceding definitions and the test and evaluation experimental design, development, and analysis are demonstrated in Table B-1.

Application of the TNF OP methodology allows for the identification and classification of the operationally influential variables and the primary process and systematic measures of effectiveness which affect the task of mission accomplishment. Only from a detailed factor or variable identification may the variables which influence the outcome of mission accomplishment be prioritized for later application to cost-effective and statistically valid operational testing programs.

B-3 DETAILED DESCRIPTION OF THE TNF OPERATIONAL PROCESS.

Using the logic of the TNF OP methodology, the general outcome of any functional activity of the TNF OP structure is influenced by the input to the activity, the state variables impacting the decision variables of the activity, the rewards and returns of the activity, and the resultant output of the activity to the next activity. This section provides the identification and detailed description of the interconnectivity of the activities of the TNF OP structure.

Table B-1. Design characteristics of TNF OP system model and translation to experimental test designs.

TNF OP SYSTEM MODEL METHODOLOGY	TNF EXPERIMENTAL DESIGN (S)
Activity (Functional Attribute)	Test Objectives (s)
Input State	Influence of Variance of Control Variables
State Variables	Control Variables and Covariates
Decision Variables	Levels of Control Variables
Rewards & Returns	Response Variables
Output State	Influence of Variance of Response Variables

The TNF OP structure should be viewed as a dual network of environmental and functional activities that are necessary for a unit to perform and accomplish its required mission. The detailed structure of the environmental and functional activities in the TNF OP is presented in Figure B-2. For illustrative purposes, the notation of the state variables, the decision variables, and the returns and rewards is omitted; however, it is understood these parameter spaces impact on the magnitude of success of each and every environmental and functional activity.

The following paragraphs present a detailed definition and discussion of these environmental and functional activities.

The environmental activities of the TNF OP structure are:

1. Environment. The environment consists of the classical enemy, weather, and terrain characteristics, and also includes the geoeconomic and geopolitical elements of such an environment.
2. Mission. The mission of any unit is a designated and justified purposeful action oriented task.
3. Role. The role of the unit is the manner or means by which a unit will adapt and identify itself in order to best accomplish its mission.

For test, evaluation, and analysis purposes, the environmental activities act as a scenario development, and therefore an evaluation and analysis dependent function.

The functional activities for the TNF OP structure are identified in order to address the question of how and to what extent a TNF unit must endure/adapt/react to accomplish its mission. The functional activities are (operational definitions derived from Reference 26):

1. Management Control (C³ I). Management control is based on knowledge and intelligence of the perceived threat and environment. The management control activity of TNF OP consists of the continuing activities of planning, organizing, directing or commanding, coordinating, controlling,

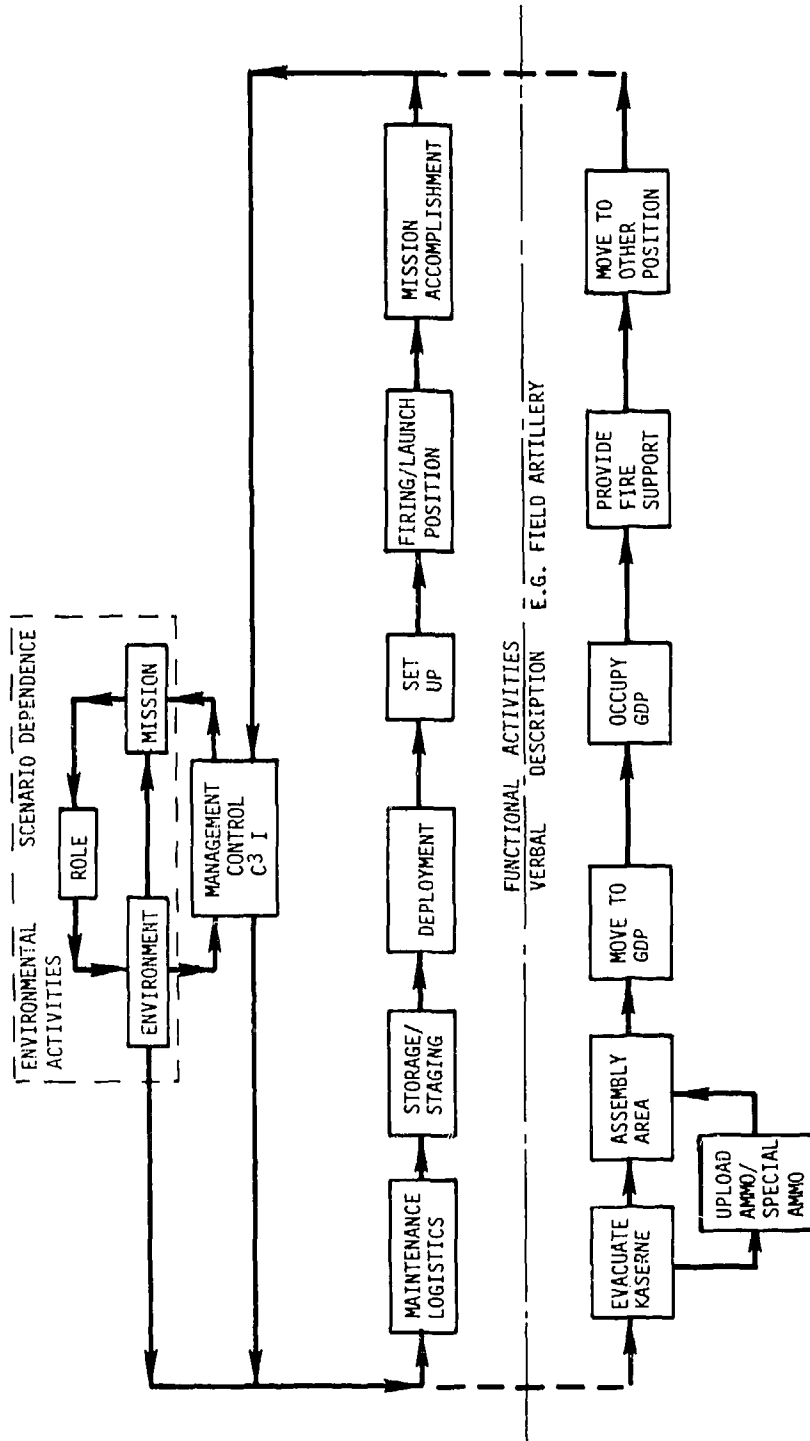

Figure B-2. TNF operational process -- detailed structure of environmental and functional attributes.

evaluating, and communicating for feedback the usage of physical, human, and financial resources perceived or required to accomplish the desired mission. The primary goal of this activity is control of resources.

2. Maintenance/Logistics. The maintenance/logistic activity addresses the activity of all action taken to retain and provide material in a serviceable condition, or restore it to serviceability, to include all maintenance, supply, and repair action taken to keep a force in condition to accomplish its mission. The primary goal of this activity is retention of material to provide service.
3. Storage/Staging. The storage/staging activity consists of the activities associated with the retention of resources in some environment for the purpose of assembling, holding, and organizing such resources for future displacement from their current environment. The primary goal of this activity is to hold resources.
4. Deployment. The deployment activity within the TNF OP encompasses all movement actions communicated and supported by movement directives and associated implementation controls, procedures, priorities, orders, requirements, and restrictions during which a designated unit relocates in order to accomplish its mission. Movement actions may include evacuation, disposition of material, and hospitalization of personnel. The primary goal of this activity is to require resources to deploy.
5. Set Up. The set up activity addresses the activities associated with the implementation and execution of all organization and movements of resources within a battle position. The primary goal of this activity is to organize resources.

6. Firing/Launch Position. The firing/launch position activity organizes all assemblages of resources and provides coordinated support to accomplish the mission. The primary goal of this activity is to provide support using the available resources.
7. Mission Accomplishment. Mission accomplishment evaluates and communicates the results of any purposeful task and such actions as may be related to the task to all activities which may consume or create a demand for resources requiring such task activity in order to plan and control anticipated tasks and subsequent results. The primary goal of this activity is to evaluate and communicate resource utilization.

Therefore, the TNF OP structure operationally relates the goal of the identification and verification of planned enhancements to the S^2 aspect of the TNF through operational tests, evaluation, and analysis efforts to the preceding environmental and functional activities any TNF unit must perform to accomplish its mission. Since all S^2 enhancement efforts are derived from inter- and intrarelated service issues, any S^2 enhancement to a TNF unit will result in an interrelated and intrarelated set of responses influencing the TNF units' mission accomplishment. The TNF OP serves as one vehicle by which the proposed enhancements may be evaluated from a relative operational result viewpoint for input to effective management implementation of such enhancements.

This characteristic is illustrated in Figure B-3 which relates the S^2 enhancement assessment methodologies and associated assessment variables to the environmental conditions with verbal descriptions of the TNF OP functional activities. Defined boundaries are omitted from the diagram; areas of environmental and functional activities' influence are demonstrated by the contraction and expansion of the illustrated response curves.

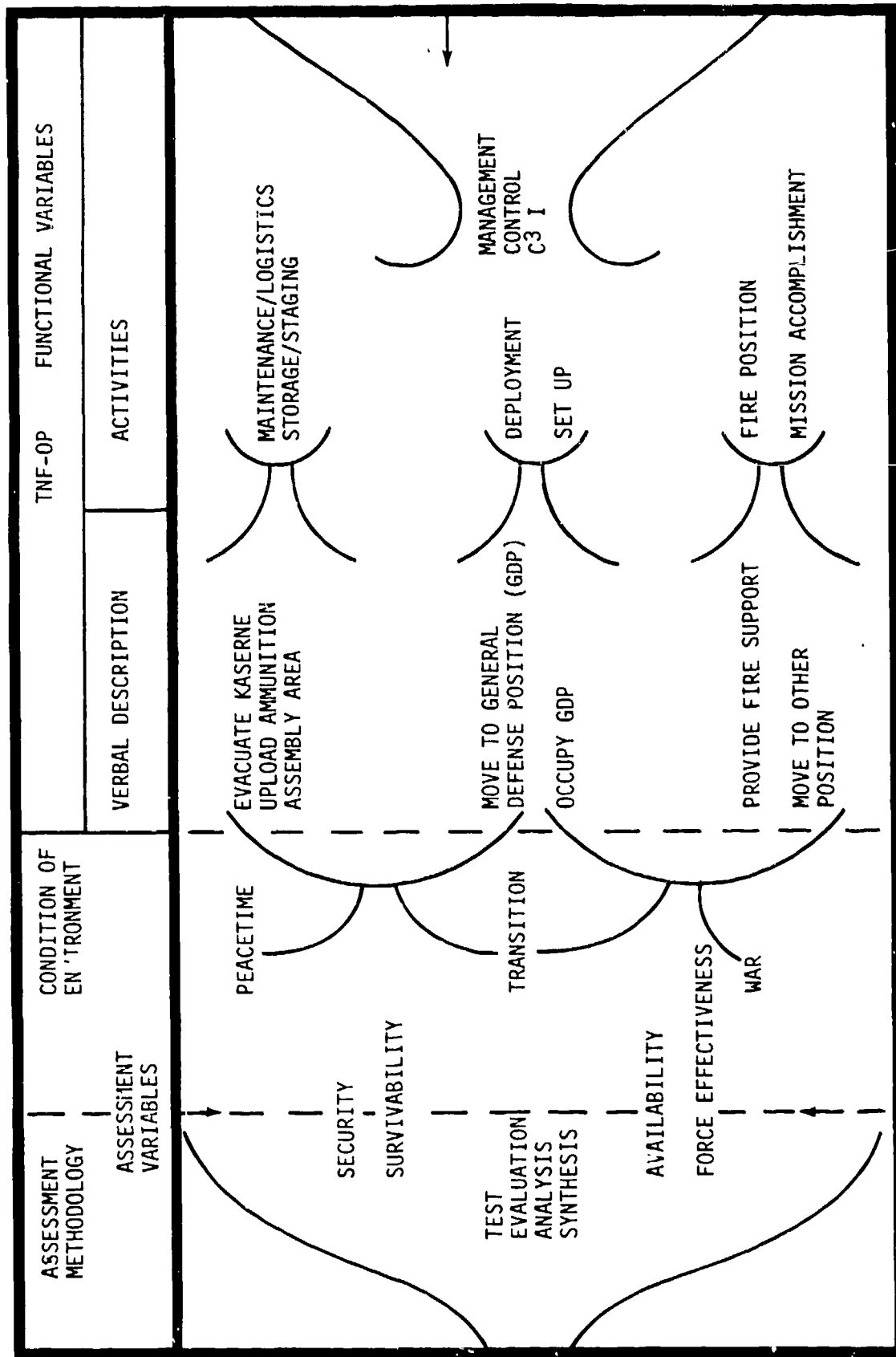

Figure B-3. Relationship of TNF operational process functional activities and verbal description with NATO/WP TNF environmental conditions to assessment methodologies.

The TNF OP structure and methodology may equivalently be viewed as a resource allocation problem in which the objective of optimizing the system is to maximize the total return of security, survivability, availability, and force effectiveness from all functional and environmental activities. From this standpoint, the objective in each activity is to determine an operationally optimal balance of resources consumed and resources still to be allocated for all activities.

B-4 OPERATIONAL EXAMPLE OF THE TNF OPERATIONAL PROCESS.

The following paragraphs present a simplistic operational example of the application of the TNF OP methodology to the assessment of enhancements and limitations in the S^2 arena of the TNF. The generic and operational definitions and interpretations of the TNF OP environmental and functional activities are from Table B-1 and Figure B-2. The elements to be presented in the following example are:

1. Test Objective (activity of TNF OP)
2. Influence of the Variance of the Control Variables (input state)
3. Control Variables and Covariates (state variables of activity)
4. Levels of the Control Variables (decision variables)
5. Response Variables (rewards and returns of the activity)
6. Influence of the Variance of the Response Variables (output state)

This example is based on information obtained from Reference 27.

Statement of the Operational Example: Evaluate the Security Effectiveness of 155 mm M109 Self Propelled (SP) Howitzer Battery during deployment from an Assembly Area to a GDP. The mission of the Battery is to provide direct support on arrival and set-up at the GDP. The battery is in a direct support battalion in the table of organization and equipment (TO&E) of a mechanized/armored division during a period of advanced state of readiness.

Figure B-4 presents a graphic portrayal of the operational example. It is assumed that the battery has arrived successfully at the assembly area and is sufficiently organized to deploy from the Assembly Area.

The test objective (stated in Table B-2) has been obtained from an analysis of:

1. The Service issue, security during deployment.
2. The Service weapon system, 155 mm M109 SP Howitzer.
3. The organizational impact of the weapons system, a 155 mm M109 SP battery.
4. The mission of the unit, direct support.
5. The policy used by the organization in the allocation of the resources, management of a mechanized/armor division in an advanced state of readiness.
6. The activity in the TNF OP structure of the unit, deployment.

The input state of deployment activity is presented in Table B-3. Note that the variables identified are for the purpose of indicating the influence of the assembly area response variables on the deployment activity control variables. Although the example addresses only one activity of the TNF OP structure, it is still necessary to identify those variables which impact the successful transfer of the 155 mm M109 SP battery from its assembly area to the deployment activity. This allows for an assessment of the variance exhibited by the variables which will be either controlled or uncontrolled during the deployment activity itself.

The state variables of deployment activity are contained in Tables B-4 and B-5. Table B-4 includes the decision variables at which the states of nature may be statistically controlled. Table B-5 indicates the state variables which cannot be controlled (the covariates). The controlled and uncontrolled variables identified in the above mentioned tables form the basis for the type of statistical experimental design to be developed and employed during the actual testing of the test objective. It may be stated, a priori, that some combination of the state variables will result in the highest "score" of security effectiveness;

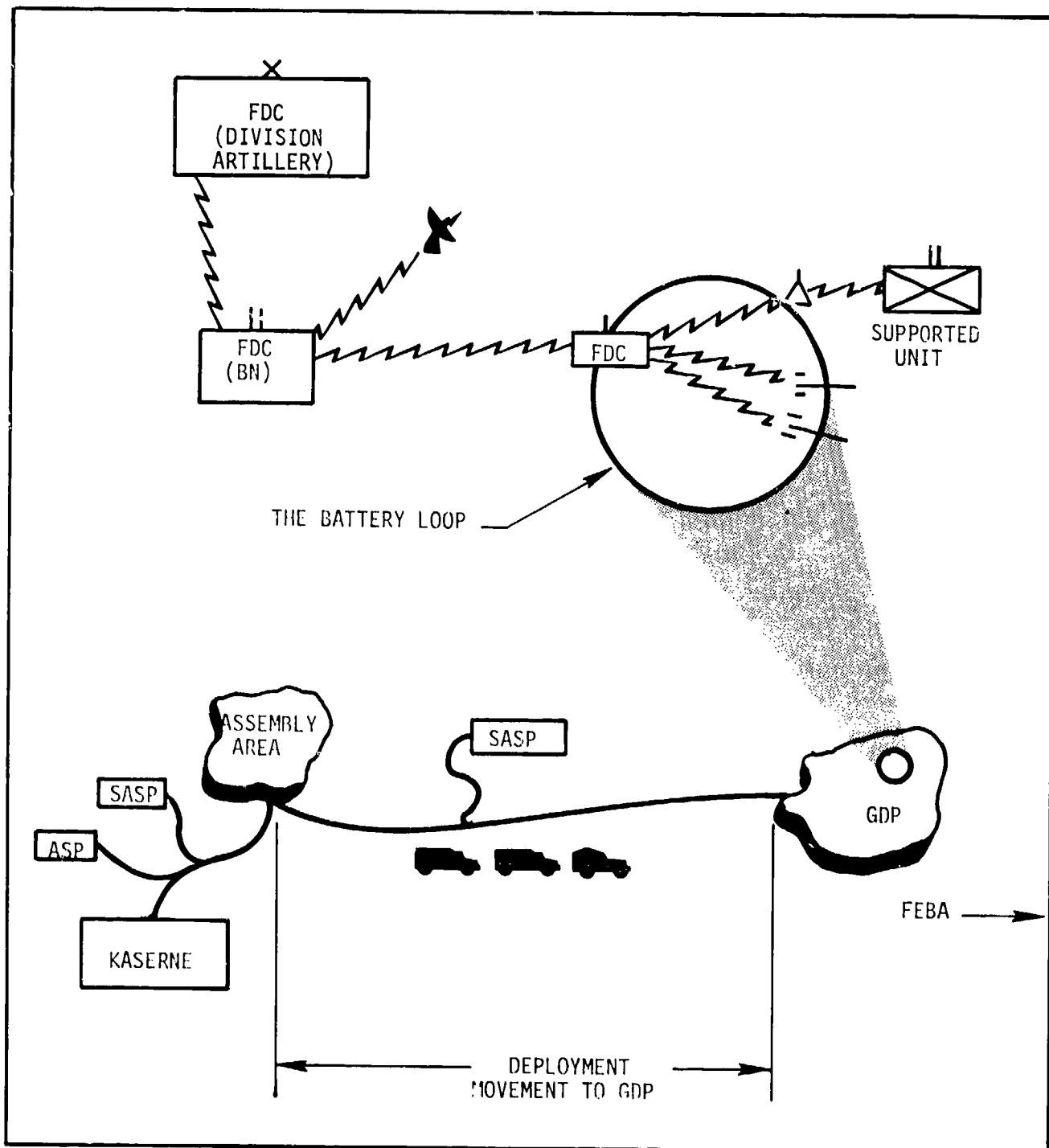

Figure B-4. Operational example -- hypothetical diagram of deployment route from assembly area to GDP.

Table B-2. Test objective in operational example --
activity in TNF OP.

TEST OBJECTIVE (ACTIVITY)

Evaluate the Security Effectiveness of a 155 MM M109 (SP)
Howitzer Battery During Deployment from an Assembly Area to
the Battery GDP.

Table B-3. Influence of variance of control variables in operational example -- input state of deployment activity in TNF OP.

INFLUENCE OF VARIANCE OF CONTROL VARIABLES
(INPUT STATE)

Availability of Key Battery Personnel at Assembly Area
Availability of Key Battery Personnel in Battery Convoy
Training History of Key Battery Personnel
Training History of All Battery Personnel
Training History of Battery Security Personnel
Higher Headquarters Deployment Controls, Directives, Priorities,
and Requirements for Common Usage of Deployment Route and Attach-
ments to Battery during Deployment
Intelligence Estimates of Threat of Assembly Area, Deployment Route,
and around GDP
Maintenance and Logistics Status of Battery Mission Essential
Equipment (to include Weapons, Ammunition, Vehicles, CBR, and
Communications Equipment) at Assembly Area
Support Requirements for Ammunition Supply (Ammunition Supply Point
(ASP) or Special Ammunition Supply Point (SASP)) at Assembly Area
Deployment Convoy Organization
Procedures and Equipment Required for Protective/Deceptive Covering
of Mission Essential Equipment at Assembly Area

Table B-4. Control variables and associated levels of control variables in operational example -- state variables and decision variables of deployment activity in TNF OP.

CONTROL VARIABLES (STATE VARIABLES)	LEVELS (DECISION VARIABLES)
Location of Key Battery Personnel in Battery Convoy	A, B, C*
Cross-Trained Status of Key Personnel	Low, High
Cross-Trained Status of Battery Security Personnel	Low, High
Threat Strength	A, B, C*
Convoy Defense/Security Strength	A, B, C*
Time of Day	Day, Night
Attachments to Battery	Yes, No
Threat Sensor/Agent Locations	A, B, C*
Battery Deployment Convoy Configuration	A, B, C*
Battery as Part of Large Convoy	Yes, No
Protective/Deceptive Covering of Weapons	Yes, No

* Levels to be determined

Table B-5. Covariates of operational example -- state variables of deployment activity in TNF OP.

AREA OF INTEREST	COVARIATE (STATE VARIABLES)
Mission and C ³	OPORD (Operation Order) Directive and Requirement of Battery Movement SOP for Battery Movement Contingency Plans for Movement Location(s) of Higher Headquarters Availability and Types of Primary Weapons/ Ammunition and Battery Equipment Maintenance Status of Mission Essential Battery Equipment Availability and Types Communication Equipment Location and Types of Radios Communications Net Structure Availability and Types of Battery Personnel Rules of Engagement Security Arrangements Location of Supported and Supporting Units Location of GDP
Intelligence Estimates	
1. Threat	Type, Location, Size, Mission of Threat Security Response to Known Threats
2. Weather and Terrain	Season, Time of Year, Time of Day/Night Precipitation Terrain Characteristics Survey Information of Terrain

Table B-5. Covariates of operational example -- state variables of deployment activity in TNF OP (Concluded).

Battery Personnel	Key Personnel Availability
	Support Personnel Availability
	Training Status of All Personnel
	Cross-Trained Status of All Personnel
	Location of Battery Control Center (BCC)
	Location of Fire Support Team (FIST)
	Location of Battery FDC
Movement Characteristics	Recon Party Information on Terrain and Route
	Route Conditions (Traffic Control, Alternative Routes)
Equipment	Number and Types of Individual and Crew Served Weapons
	Number and Types of Section Equipment (Including Survey)
	Number and Types of Special and General Purpose Vehicles
	Number and Types of Conventional and Special Ammunition
	Location of Special Ammunition Supply Points (SASPs) and Ammunition Supply Points (ASPs)

the operational test under the conditions prescribed by the state variables and the associated decision variables will allow for this interpretation.

The rewards and returns of the deployment activity are contained in Table B-6 and identified as the response variables of the operational example. Response variables are synonymous with the term Measures of Effectiveness. Since, in many cases, these are statistical parameters, the response variables under investigation may be average values, variances, or maximums or minimums. The response variables identified account for the quantitative, or, as the case might be, qualitative, representation of the 155 mm M109 SP battery's security effectiveness for a particular combination of the state and decision variables. As previously stated, some combination of the state and decision variables will result in the "best" security effectiveness, where security effectiveness is defined by the response variable representation.

The output state of the deployment activity is an assessment of the influence of the variance of the response variables (Table B-7). Identification of the output state of the deployment activity allows for the development of the transfer function which describes the security effectiveness of the 155 mm M109 SP battery as it reaches the GDP and begins the activities required and associated with the provision of direct support for the mechanized/armor division. Based upon the security effectiveness exhibited during the deployment activity, the TNF OP methodology then requires the subsequent assessment of the battery security effectiveness after the battery occupies the GDP and begins to attempt to accomplish its mission.

From the information contained in the preceding tables, an experiment may be designed, developed, planned, and accordingly implemented to satisfy the test objective. A cursory examination of the magnitude of the repeated observations required to fulfill a randomized factorial experimental design reveals that an effective approach to evaluating the test objective would obviously include the development of test subobjectives and, hence, other related experimental designs.

Table B-6. Response variables of operational example --
rewards and returns of deployment activity of TNF OP.

AREA OF RESPONSE INTEREST	RESPONSE VARIABLES (REWARDS AND RETURNS)
Detectability of Battery Movements	Number of Movements Detected Time of Movement Detection
Identifiability of Battery Movements	Number of Movements Correctly Identified as Battery Movements Time of Correct Movement Identification
Attacks on Battery Movements	Number of Battery Elements Attacked Time of Attack Type of Element Attacked
Response by Battery to Attack	Time Battery Response Force Alert to Attack Time of Battery Response Force Arrival Time of Battery Security Force Alert to Attack Time of Battery Security Force Arrival Number of Correct Responses by Battery (during which the attack was not a deception) Time of Attack Detection Time of Augmentation force Alert to Attack Time of Augmentation Force Arrival
Defense Capability of Battery	Number of Successful Attacks on Battery Number of Attacks Defeated by Battery

Table B-6. Response variables of operational example --
rewards and returns of deployment activity of TNF OP
(Concluded).

	Time(s) of Successful Attacks on Battery
	Time(s) of Attacks Defeated by Battery
Threat	Number, Location, and Type of Threat Attacking Battery
Battery Movement	Time of Departure from Assembly Area
	Time of Arrival to GDP
	Number of Halts
	Rate of Movement

Table B-7. Influence of variance of response variables in operational example -- output state of deployment activity in TNF OP.

INFLUENCE OF VARIANCE OF RESPONSE VARIABLES
(OUTPUT STATE)

Detectability of Battery Upon Arrival at GDP
Identifiability of Battery Upon Arrival at GDP
Attacks on Battery Upon Arrival at GDP
Security of Battery Upon Arrival at GDP
Availability of Battery Personnel and Equipment Upon Arrival at GDP
Intelligence Estimates of Threat at GDP
Communications of Battery to Higher Headquarters at GDP

The variables identified from the TNF OP methodology provide the necessary information to feed the evolving Data Requirements List for the Data Management System. These variables, when broken down into data measurements, also provide the guidance for selection of the analysis methods required to treat the specific data. Techniques as presented in section 3-2, and other techniques as appropriate to the problems under investigation, will be used for planning and treatment of S² enhancement option experiments, studies, and related data.

It is emphasized that the operational example is simplistic enough and sufficiently developed to assess a sizeable portion of the variables influencing Deployment of a 155 mm M109 SP Howitzer Battery. Further elaboration would incorporate the remaining activities of the TNF OP as they relate to the four primary elements of the Field Artillery System to include C³, Target Acquisition, Orientation (Gunnery), and Weapons and Ammunition.

APPENDIX C
RANGE/EXERCISE FACILITIES

C-1 GENERAL.

Issues for early testing have been identified for both Army and Air Force elements of the TNF. The following paragraphs comprise an overview of some existing facilities where specific TNF testing could occur. The items of general interest are:

1. Physical Characteristics
2. Instrumentation, Data, and General Support Capabilities
3. Special or Unique Capabilities and Limitations

The material contained in this annex has been largely summarized and paraphrased from existing documentation.

C-2 FORT HOOD.

C-2.1 Physical Characteristics.

The Post, 65 miles north of Austin, Texas, varies between 600 and 1200 feet above sea level.

The Fort Hood area, near the boundary of two major climatic zones (the semi-arid zone on the west and the warm, rainy zone on the east), has a warm, temperate, rainy climate, with dry summers. Annual precipitation averages 30 inches, mostly rain showers and thunderstorms with long periods of light rain in winter.

The terrain at Fort Hood is dominated with rolling hills. The test areas on west Fort Hood and southwest Fort Hood have rather sparse vegetation and these areas are considered to be good terrain for European theater simulation. The east Fort Hood test area has heavier vegetation and has been utilized for Asian theater simulation. The only significant body of water in the area is the Belton Reservoir.

Fort Hood occupies 218,000 acres of land area. It consists of four small inhabited areas plus large impact and maneuver areas.

All the test areas are contiguous and surround the impact area. However, practical consideration concerning mass troop movement

across Highway 190 separates the Post into a north and south area with all firing occurring in the northern area.

Figure C-1 is a map of the Fort Hood facility showing the restricted air space R-6302.

C-2.2 Support Capabilities.

C-2.2.1 Military Units. Fort Hood is the home of the III Corps, 1st Cavalry Division, 2nd Armored Division, 13th Support Brigade, and Headquarters of TRADOC Combined Arms Test Activity (TCATA). TCATA is the only tenant with a true operational test and evaluation capability.

TCATA, with the cooperation of the III Corps, is capable of evaluation in the following areas:

1. Helicopter
2. Tanks
3. Ground Mobility
4. Intelligence and Target Acquisition
5. Threat Environment
6. Camouflage
7. Command, Control and Communications
8. Airspace Control
9. Reserve Components
10. Logistics and Control

Many uncontrollable factors, along with schedules and routine requirements, limit use of troop units. Further investigation of the user requirements as a function of quantity, extent of need, and time frame required, correlated with existing or planned other user needs already scheduled for these units, will be required.

The III Corps provides the standard corps complement of equipment repair and maintenance shops. These include aircraft, automotive vehicles, combat vehicles, construction equipment, electronic and communication equipment, missiles, armament, general equipment, and calibration.

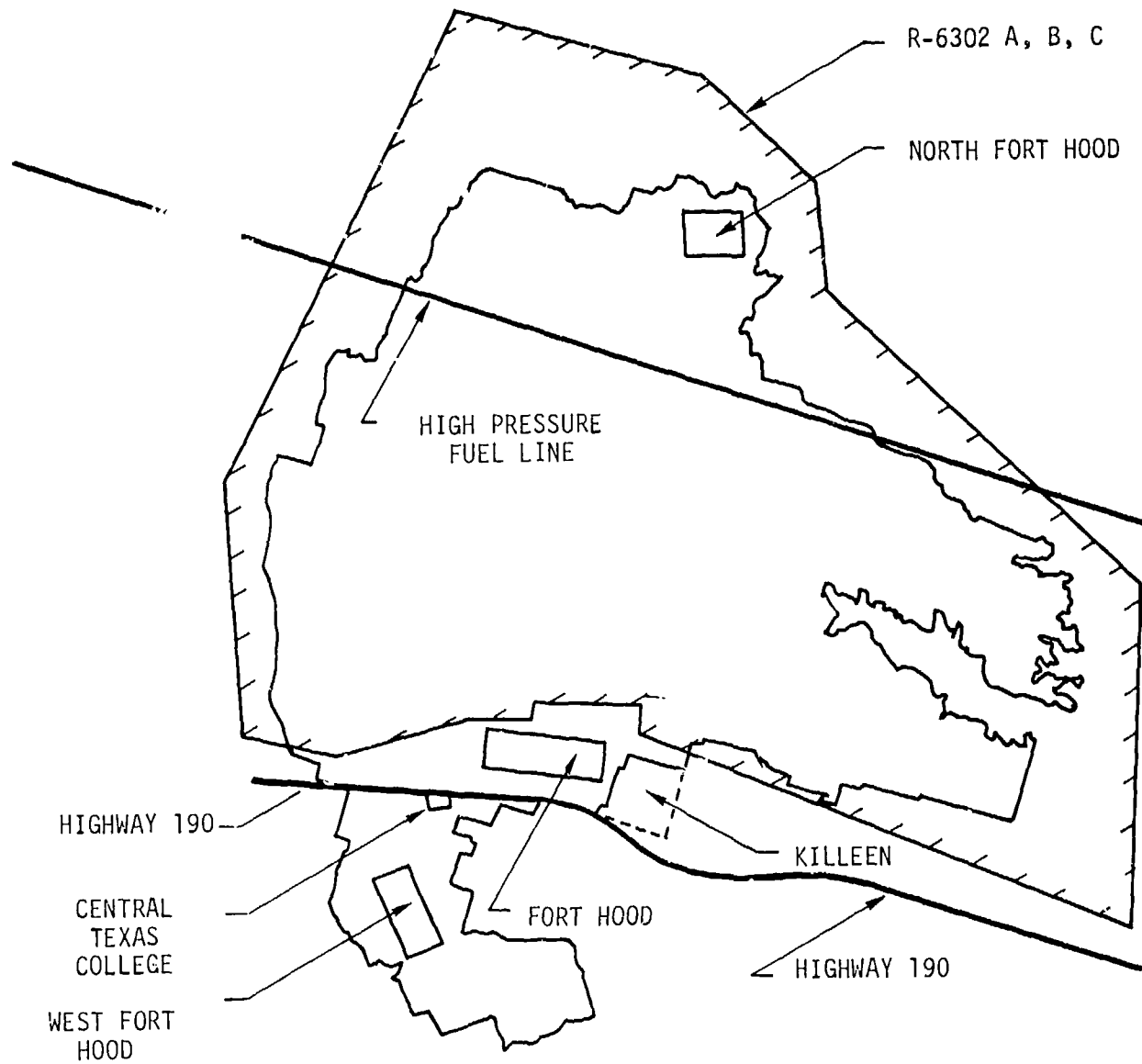

Figure C-1. Fort Hood area and restricted airspace.

Specialized maintenance support for the TCATA test instrumentation system at Fort Hood is provided by TCATA itself.

Housing and mess facilities exist at North Fort Hood for 8,000 additional troops. These facilities at North Fort Hood are used during the summer by the National Guard and Reserve Units for summer camp and are vacant the remainder of the year.

C-2.2.2 Communication. Communication is restricted to land lines on the test ranges plus the standard Corps-level radio communication. There are no special communication facilities for test purposes.

C-2.2.3 Instrumentation. The prime instrumentation source is within TCATA. The TCATA instrumentation consists of three large range instrumentation systems plus a collection of minor equipment items. The minor equipment items consist primarily of photographic equipment, meteorology equipment, photometric, audiometric, and timing equipment. The PRRS (Position Reporting and Recording System) is completely assembled and functioning. The ADCS (Automatic Data Collection System) has been completely assembled on site and is functional.

The Position Recording and Reporting System (PRRS) is a position-determining system used to monitor the position of several hundred test elements. Its primary features are:

1. Determines real-time position of Mobile Units simultaneously.
2. Mobile Units (weighing approximately 10 pounds) easily attach to jeeps, tanks and other ground vehicles, helicopters, as well as to infantry in a back-pack configuration.
3. Mobile units require essentially no attention on the part of the player personnel or vehicle to which they are attached. PRRS provides position fixing of all types of elements within a 20 x 25 mile rectangle.

4. Provides position fixing of helicopters with the degraded performance up to 50 miles from the center of the Fort Hood base.
5. Records position data for posttest review and analysis, and displays real-time position data graphically for test monitoring purposes.
6. Operates on a ground wave principle and thus its performance is not degraded by terrain masking.

Various real-time display scales from the entire Fort Hood area down to a 3.5 x 3 kilometer section can be accessed for display purposes. The display consists of a terrain background picked up from a film slide chain and camera with computer output data overlaid on the ground. The computer provides the positions of mobile units with their identification numbers on the terrain background. Symbols identify the type of player to which a mobile unit is attached. As mobile units move, they can leave a trail on the display showing the past history of their movement.

The Weapons Engagement Scoring System (WESS) provides a tool for TCATA to evaluate weapon engagement events. WESS is used to simulate various attack-target events. WESS is integrated into the present PRRS and the ADCS. The major subsystems are a Laser Weapon Simulator, Signal Processing and Control Logic Unit, and a Detector Array Subsystem. The WESS employs both ground and airborne types of laser weapon simulators.

TCATA currently has black and white TV camera/video tape recorder/monitor systems. Fort Hood has a mobile TV system which is available to TCATA. An extensive number and variety of still and motion picture cameras are available. Facilities are available at Fort Hood for the calibration of all test and measuring equipment used by III Corps or TCATA. There is no stand-alone telemetry equipment at TCATA other than that contained in the PRRS, ADCS and WESS. TCATA has a limited ability to measure sound using an octave band analyzer and sound level meters.

C-2.2.4 Data Collection and Processing. The Automatic Data Collection System (ADCS) is designed to relay data by RF and wire from various points within a test zone to a central recording system (RS) van. An RS van can support one and only one test operation and the system includes three RS vans so that three tests may take place simultaneously in different sections on the base. The messages received at the RS van are stored on magnetic tape and up to 10 BPD's data can be printed out in real-time under computer control within the RS van. In addition, the RS van has the necessary computer facilities to do calculations and data formatting for real-time printout or display on a CRT. The RS van has the capability of sending control messages.

Primary airspace surveillance is visual. However, radar surveillance of Fort Hood is possible using the Approach Surveillance Radar (ASR) located at Hood AAF or Robert Gray AAF.

C.2.3 Special Capabilities and Limitations. With support from Fort Hood facilities and the III Corps resources, TCATA can conduct tests up to the scale of battalion operations including infantry, armor, helicopter, and support elements. Instrumentation provides the capability for position fixing, automatic data collection at central sites, and weapons scoring of several hundred elements. It is possible to closely monitor simulated firing engagements of a large number of elements. This capability has been tailored particularly for monitoring engagements between large helicopter and armor forces. In addition, the position fixing and data collection capability is well suited to monitoring ground force activities since both of these systems use small field equipment that can be carried by infantry personnel and field test monitor personnel without serious impact by the instrumentation on the realism of the simulation.

Special consideration must be given in any test planning to a high-pressure fuel line that crosses Fort Hood in an east-west direction approximately 12 miles north of the Main Post area. Crossing of the

underground pipeline is allowed only at designated points. No dud munitions are allowed north of the pipeline.

Throughout the summer months, Reserve and National Guard units utilize North Fort Hood and some of the firing ranges and maneuver areas.

One noticeable test constraint resulting from the semi-arid nature of the terrain is the fact that during daylight hours, at virtually all times of the year, tracked vehicles and, to a great degree, other types of vehicles leave significant dust trails when they move. Their movement is obvious to all.

R-6302, above Fort Hood, is restricted to all aircraft to 30,000 feet above mean sea level at all times. In addition, past tests have involved helicopter operations in areas surrounding the restricted airspace. Only helicopter and light aircraft operations are permitted at Fort Hood.

Cattle grazing is allowed on most areas of Fort Hood. Some hunting and forestry is also allowed which may present some operational problems during certain times of the year.

Ranges are available on Fort Hood to support all the weapon systems used by the III Corps.

C-3 FORT ORD/HUNTER LIGGETT.

C-3.1 Physical Characteristics.

Fort Ord is located near Monterey, California and Fort Hunter Liggett is located near King City to the south (Figure C-2).

HLMR is characterized by relatively cool winters and extremely hot summers. Average annual rainfall in the HLMR area is influenced by the coastal mountains, it averages 16 inches on the coastal slopes, 15 inches at the airstrip and 11 inches at King City. Wind speeds are usually light; especially in the valleys.

HLMR (Figure C-3) averages 11 miles in width and 26 miles in length. The entire reservation is interspersed with hills and mountains. The Nacimeinto River is generally intermittent and narrow with only one

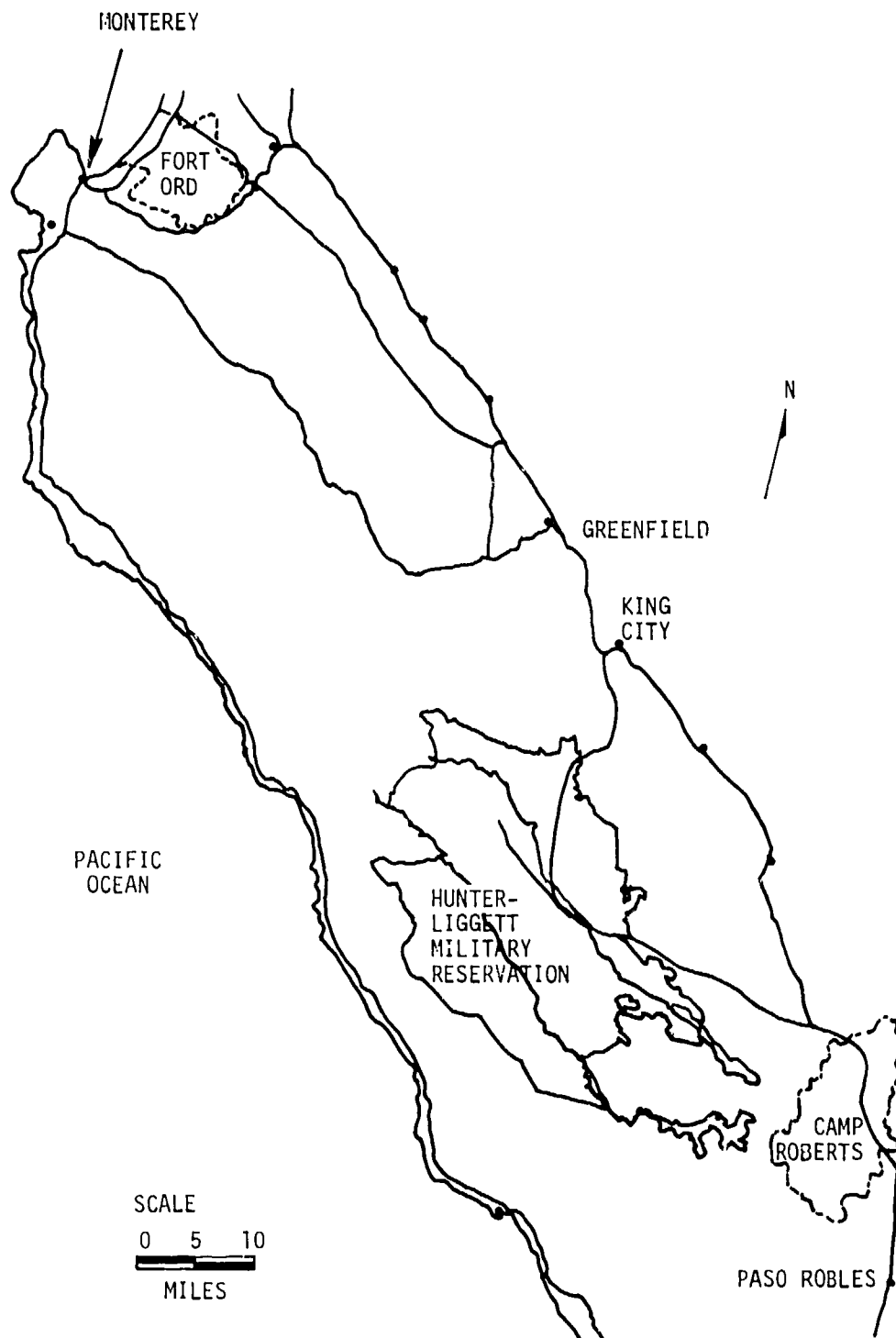

Figure C-2. Fort Ord and Hunter-Liggett area.

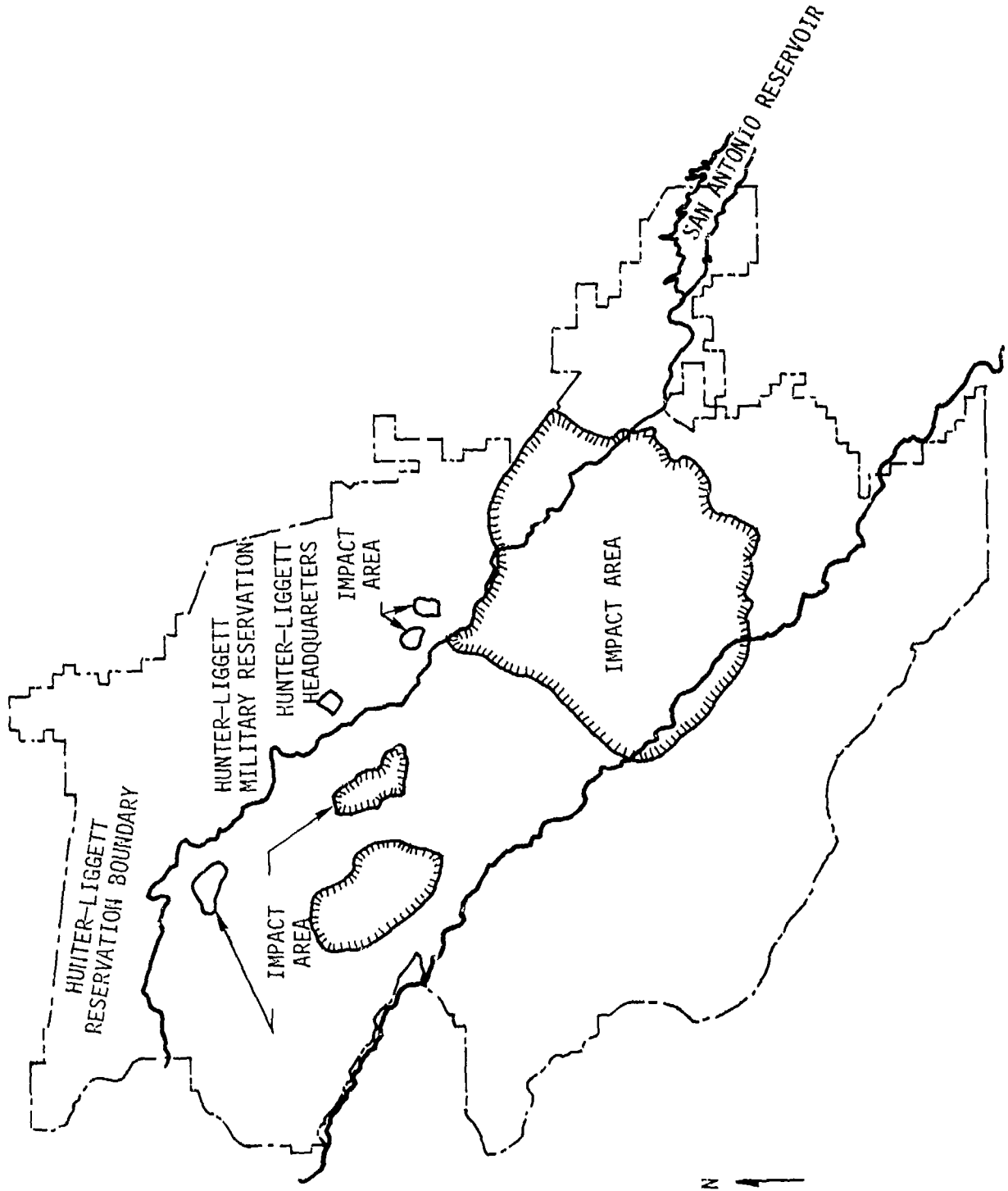

Figure C-3. HLMR with impact areas.

appreciable flood plain, the San Antonio reservoir area has a significant amount of relatively flat ground that is suitable for many uses. In addition to the San Antonio and Nacimiento Rivers, there are approximately 23 reservoirs of various sizes.

C-3.2 Support Capabilities.

C-3.2.1 Military Units. The Fort Ord complex is comprised of the 7th Infantry Training Center and two satellite installations. These are the Presidio of Monterey and Fort Hunter-Liggett (FHL). Fort Ord serves as the administrative and planning center for the U.S. Army Combat Developments Experimentation Command (CDEC) whose experiments are conducted at FHL (See Figure C-2).

CDEC is a subordinate unit to HQ TRADOC. It is a military field laboratory where TRADOC conducts experiments with combinations of men, tactics, equipment, and organizations to determine solutions to combat development problems. The Experimentation Support Command at FHL provides troop equipment and logistical support for CDEC field experimentation and participated in contingency operations as directed by CDEC.

The Engineer Company provides general engineer support of experimentation as required.

The Instrumentation Company provides command, control, administrative, and supply support for all Instrumentation Company personnel and support, as necessary, to Instrumentation personnel operating at HLMR.

The Maintenance Company provides direct support maintenance service for CDEC material except medical, chemical, quartermaster, cryptographic, instrumentation, ADPS, and aircraft items. It also provides maintenance contact teams to experimentation sites if density of equipment so warrants.

Infantry Companies A and B provide personnel and small infantry units in support of experimentation.

The Transportation Company provides vehicles to all CDEC elements for the movement of personnel and general cargo by motor transportation in support of experimentation.

The Armor Company provides Combat Vehicle Support for experimentation. The 155 Aviation Co. participates in combined arms experimentation and provides troop lift capability.

C-3.2.2 Scientific Support Laboratory (SSL). From the onset of CDEC, the experimental battlefield has been a joint military-scientific creation with a fusion of military experience with scientific methodology. The Scientific Support Laboratory, manned since 1971 by The BDM Corporation, presently employs 220 scientists, engineers, and technicians providing support in the following areas: project planning and analysis, instrumentation engineering development and support, operations and maintenance of selected instrumentation systems.

C-3.2.3 Power and Communications. Electrical power is provided to the Alamo Bivouac Area, Headquarters Airfield Area, Mission, Forest Service Area, Jolon Bivouac Area, Site Bravo, Bald Mountain, Site 32, CPSS Site, Live Fire Complex, Repeater Hill and Site 8X Complex. Other bivouac areas and CDEC experimentation sites are served by portable generating plants.

Communications are virtually unlimited.

C-3.2.4 Instrumentation The Range Measuring System (RMS) was conceived as a means of rapidly determining the timing and position of men, vehicles, and aircraft in a mock battle. The system currently consists of the following basic components: 43 "A" stations, 60 "micro B" units, 4 "C" stations, and 3 "D" stations. The A station, an interrogator station, is a semifixed

radio link between the C station and the field units (micro B units). The C station is either a fixed position hardware complex, or a mobile master control station. Event information can be transmitted from micro-B units either by manual entry or direct interfacing. Two way communications exist which allow for real-time casualty assessment. Typical accuracy of ± 5 meter in the X-Y plane is produced. Radio line-of-sight is required between any two RF communicating components. When micro-B units are used with self contained batteries as a source of power, the batteries must be changed every several hours.

The Direct Fire Simulator (DFS) is integrated with the RMS and simulation software. The mobile elements of the DFS are carried by personnel, vehicles, and helicopters. Laser beam transmitters simulate weapons fire, and laser detectors on the players register incident energy. Real-time casualty assessment is possible through the integrated system. A plug-in module concept provides instrumentation flexibility. An indirect fire system is being developed.

FHL also has a computer controlled live fire range complex with moving and pop-up targets.

Range timing is FM distributed WWV.

A laser sensitive television monitoring system is planned.

Telemetry is integral with the major systems.

Pacific missile range will send EMI surveillance teams at CDEC request.

C.3.2.5 Data Processing and Control CDEC has a Multiple Computer System (MCS) to control the test and to process data. A DEC system 1060 and 12 interfaced PDP 11/45's furnish primary computing power for real time casualty assessment force-on-force testing.

The Data Acquisition and Recording System (DARS) collects real-time data from various remote locations. The data is time tagged and organized automatically. A DEC PUP-8 computer is at the heart of DARS. An important feature of DARS is its mobility and flexibility.

C-3.3 Special Capabilities and Limitations.

CDEC, although only a tenant at Fort Ord, is the only organization at Fort Ord that possesses a true operational test and evaluation capability. The CDEC's major testing capabilities include:

1. Mounted Combat Operations
2. Dismounted Combat Operations
3. Indirect Fire Support Operations
4. Aircraft Operations
5. Combat Support Operations

The remoteness of FHL makes it an ideal site to conduct experiments in that variables attributed to man can be controlled. Simulations of combat conditions are possible over a wide variety of terrain conditions. Remote airspace above FHL permits only restricted employment of indirect fire weapons and Army aviation experiments. Nighttime experimentation is possible due to the low artificial light levels on the reservation. Radio frequency interference is minimal.

During the months of June and July, the National Guard and Army Reserve utilize FHL on a first priority basis. There are several 2-week training periods dispersed throughout these months. Presently there are no special operating restrictions governing the use of FHL.

From November to March, rainfall causes an extremely muddy condition to exist. This severely limits cross country vehicle travel. There are presently large areas leased for cattle grazing purposes.

CDEC presently has no system that can provide accurate line-of-sight data between two players in a real-time mode. However, such a system should be soon operational.

C-4 FORT SILL.

C-4.1 Physical Characteristics.

Fort Sill Military Reservation (Figure C-4), located in Comanche County, Oklahoma, is 4 miles north of Lawton. Fort Sill is the home of the U.S. Army Field Artillery School (USAFAS). The U.S. Army Field Artillery Training Center, the III Corps Artillery, and the Field Artillery Board are also located at Fort Sill.

The occupied area of the installation is built on a level plain south of Medicine Creek and west of Cache Creek with the Wichita Mountains further to the west. The Wichita Mountains Wildlife Refuge under the Department of the Interior occupies the main portion of the mountains (a tract of 61,480 acres).

The part of the reservation which lies east of the railroads and Highway 277 is rolling prairie formation, thinly wooded along the small creeks, and more densely timbered along Cache Creek. To the west of Highway 277, starting about a half-mile north of the maintained area of the installation, is the start of the Wichita Mountains, which extend in a belt about 35 miles to the west and average four miles in width.

The Fort Sill Military Reservation consists of over 90,000 acres of which more than 50,000 acres are maneuver area.

In addition to the Fort Sill Military Reservation, an area of 34,315 acres is used for training purposes, subject to the restrictions imposed by the Fish and Wildlife Service. This acreage is part of the Wichita Mountains Wildlife Refuge, under the Department of the Interior.

C-4.2 Support Capability.

C-4.2.1 Military Units. The following list of Army units located at Fort Sill will provide some insight into the facilities and capabilities available to the outside user. However, many factors such as scheduling and routing requirements may limit the use of some of the listed units.

1. U.S. Army Field Artillery School
2. U.S. Army Training Center - Field Artillery

AREA I AERIAL TRAINING ONLY
AREA II AIR MOBILE TRAINING ONLY
AREA III MANEUVER

○ APPROVED BIVOUCAC AREAS

▨ OFF LIMITS AREAS PLUS ALL PICNIC
AND COMPOSITE AREAS

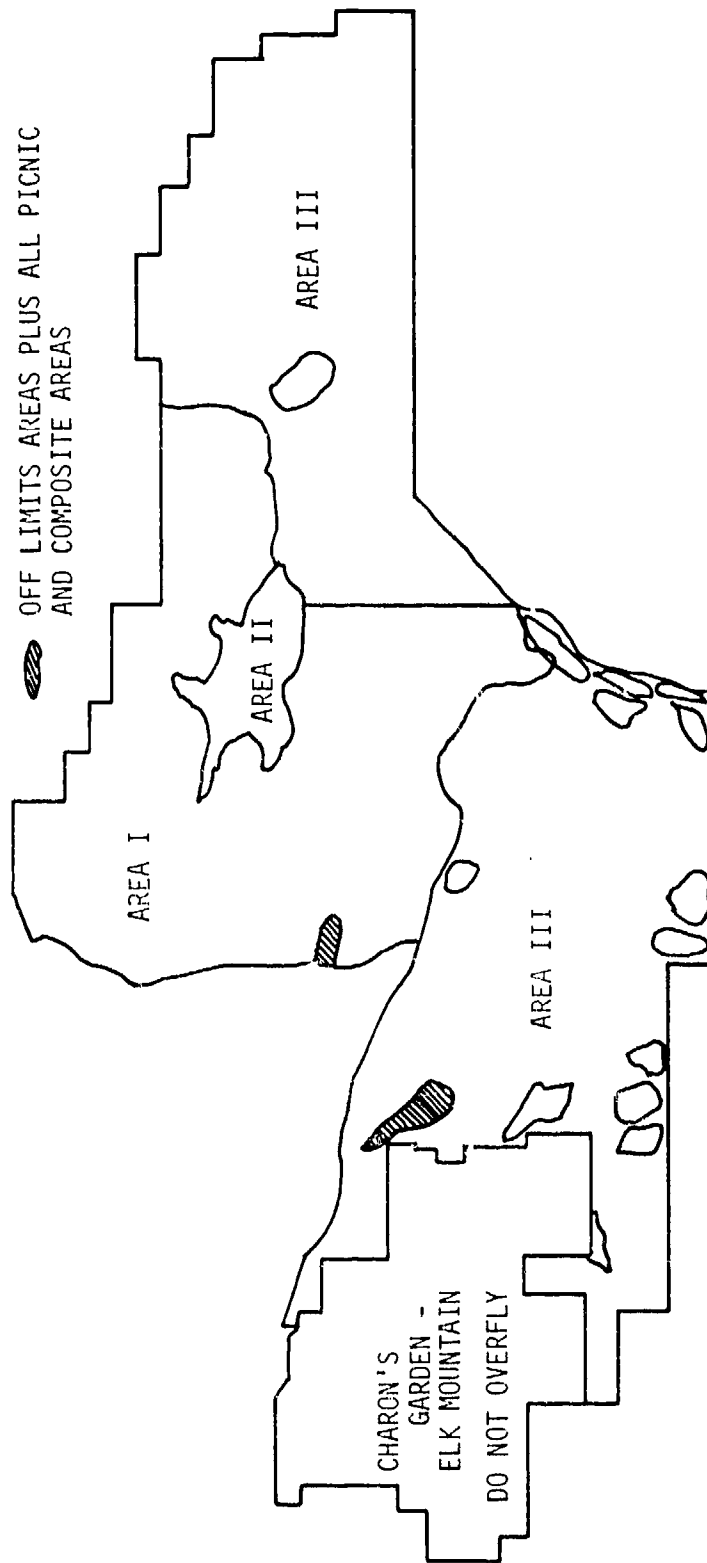

Figure C-4. Fort Sill areas.

3. III Corps Artillery
4. U.S. Army Field Artillery Board
5. 100th S&S Bn
6. 14th Aviation Battalion

C-4.2.2 Communications. All communications used by the USAFABD, artillery units, and range installations are standard military units. The Board uses both portable and/or vehicle-mounted radios of various types on a loan or in-house basis for the majority of their requirements.

C-4.2.3 Instrumentation. The Board instrumentation facilities are used primarily for testing artillery pieces, projectiles, and C³ systems. Most of the equipment used by the Board is standard "Army issue" and may not be acceptable for specific use.

The present Board capability for locating field artillery bursts is the Projectile Airburst and Impact Locating System (PAILS)--an optical triangulation system.

An AN/MPQ-4A radar set is used to adjust low-velocity field artillery fire. This is a mobile intercept-type (non-tracking) radar. An AN/MPQ-10A (tracking) radar set is used to locate and track field artillery projectiles.

The only sources of time correlation either on Post or at the Board are stopwatches. Time code generators are not used.

Limited amounts of television and photographic equipment are available, most of which are not integrated into larger data systems.

There is no telemetry capability. The meteorological system uses standard military equipment.

There is no CBR instrumentation.

C-4.2.4 Data Collection and Processing. These functions are primarily manual. There are no data storage/retrieval capabilities.

The Board has an IBM 360/20 terminal connected with the 360/50 at White Sands Missile Range (TEAM-UP West).

Ballistic data reduction is run on the Field Artillery Digital Automatic Computer.

C-4.3 Special Capabilities and Limitations.

The USAFABD at Fort Sill is the only organization whose mission is operational testing. It is a TRADOC asset. Fort Sill is primarily concerned with its training mission, but as the combat developer of the field artillery it is involved with experiments and testing of concepts and material. Scheduling for range and troops in support of tests is a routine matter.

The type of tests that have been performed on the firing ranges of Fort Sill include the following:

1. Direct Fire - rifles, machine guns, and submachine guns.
2. Indirect Fire - 8 inch, 105mm, and 175mm Howitzers and guns; surface-to-surface missiles such as LANCE, HONEST JOHN, SERGEANT, and PERSHING.
3. Airborne Systems - helicopters, helicopter weapon systems.
4. Vehicles - tanks, self-propelled Howitzers.
5. Command and Control - automated systems for the direction of artillery fire such as the Field Artillery Digital Automatic Computer (FADAC) and the more automated Tactical Fire Direction System (TACFIRE).
6. The FIREFINDER counter mortar and counterbattery radar systems.

The artillery range can accommodate firing of any standard and approved field artillery weapon and ammunition. Also available are training areas, lakes, streams, an ammunition effects field, and a cross-country vehicle test course with a fording and swimming area. There are numerous authorized field strips and designated helicopter landing sights.

One of the major activities at Fort Sill is the U.S. Army Field Artillery School, where more than 22,000 officers and enlisted men are instructed annually by six departments and trained in more than 50

courses on various phases of field artillery, howitzers, rockets, and surface-to-surface missiles. These weapons may be required to fire conventional, nuclear, or chemical warheads.

During the summer, there are reserve unit training periods. In addition, these reserve units utilize firing ranges and some "maneuver" areas.

Airspace R-5601A, adjoining Henry Post AAF and covering Fort Sill, is restricted continuously to aircraft operations from ground level to 23,000 feet.

In addition to the small arms and crew-served weapon training facilities and courses, there is also the Quanah Special Effects Field.

With the exception of the impact areas, the entire range may be used for tactical training and maneuvers. In addition, the Wichita Mountain Wildlife Refuge also contains military maneuver areas.

C-5 FORT BENNING.

C-5.1 Physical Characteristics.

Fort Benning (Figure C-5) is located adjacent to Columbus, Georgia. The Fort Benning reservation encompasses 182,247 acres. Georgia precipitation averages 49 inches a year. The rainiest months are July and August and the driest are October and November.

The Fort Benning region is a monotonous hill-land of moderate relief which is drained largely by the Chattahoochee River and its network of major and minor tributaries. On the Chattahoochee, floods may cause backwater flooding along the lower courses of its tributaries; maximum relief of the area is 600 feet. Flood plains and terrace remnants along the larger valleys comprise the most extensive areas of level terrain. Upland summits provide small areas of slight relief. Soil erosion is especially active in parts of the area where vertical-walled gullies, commonly as much as 25 or more feet deep, have been developed in the poorly consolidated sandy formations.

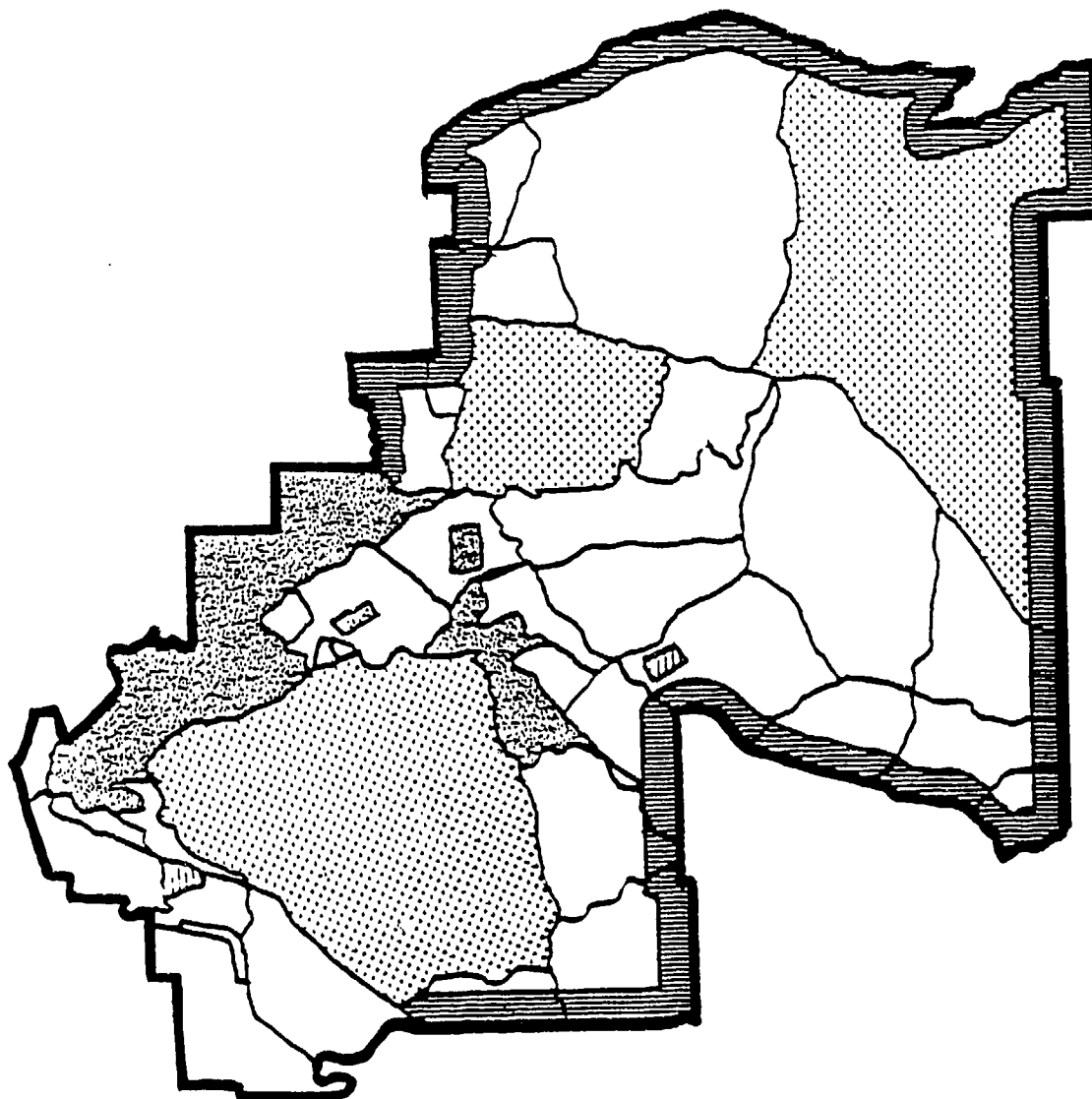

NOTE: CLEAR AREAS ARE
AREAS USED PRIMARILY
FOR TRAINING







-  AREAS PRIMARILY FOR FIRING
-  200-METER BUFFER ZONE
-  1,000-METER BUFFER ZONE
-  AMMUNITIONS STORAGE AREA
-  ADMINISTRATION & CANTONEMENT AREA
-  RECREATION AREAS

Figure C-5. Fort Benning area.

C-5.2 Support Capabilities.

C-5.2.1 Military Units. The following list of Army units presently located at Fort Benning will serve as a partial insight to the basic ability and types of support that can be obtained by an outside user.

1. The U.S. Army Infantry School.
2. The U.S. Army Infantry Board
3. Ranger and Airborne Schools
4. The 197th Infantry Brigade Contains infantry, artillery, and armor battalions and an engineer company.
5. The 931st Combat Engineer Group contains engineering and maintenance.

The Infantry Center's maintenance capabilities are very extensive, including organizational and general support for all types of maintenance/logistical support required by outside users would probably be available without major problems.

C-5.2.2 Power and Communications. No commercial electric power is available at any of the USAIB ranges or test areas except Farnsworth. The Infantry Board and Center use mobile, standard military generators to meet power requirements at the various ranges.

All communications used by the Infantry Board, Infantry Center, and range control installations are standard military equipments. The Board uses both man-portable and vehicle-mounted radios of various types on a loan basis as needed for the majority of their requirements. The Center relies on the Army supporting units for communications. Landlines for telephones are installed on most ranges.

C-5.2.3 Instrumentation. The center has no Time Space Position Instrumentation (TSPI) capability for either ground or airborne units. The Infantry Board's Quick-Fire Range is equipped with numbers of pressure pads and IR beam-breaking devices to detect the passage of test personnel. The output of these elements are fed via wire to a computer located nearby.

No radar is used by the Center or Board.

There is no primary timing capability at the Center.

The Center has limited amounts of video and photographic equipment, but no comprehensive test support capability in this area.

There is no telemetry capability at the Center. The Board acquired a short-range RF one-way system used for psychological data transmissions from test subjects.

The Board has a very limited meteorological capability.

There are no EMI or CBR instruments available.

The Center and Board capability with threats and targets in force-on-force or one-sided engagements consists entirely of stationary and moving silhouette targets. Target movement and scoring is controlled by computer with microphone and target hit inputs by RF channel.

C-5.2.4 Data Processing and Test Control. The Board has two field-use digital computers: a Digital Equipment Company PDP 15/30 system and a Hewlett-Packard 2116A system. Both are installed in air-conditioned mobile vans.

The Board also has access to the 360/65 system located at Aberdeen Proving Ground, via a 360/20 terminal.

There are no displays, plotting boards, or CRT's available.

C-5.3 Special Capabilities and Limitations.

The mission of the Fort Benning facility is to control, train, and provide administrative and logistical support for all units assigned or attached, to operate the U.S. Army Infantry School and Training Center, and furnish support to all units and activities tenanted at Fort Benning. The facilities and range areas of Fort Benning are primarily designed for and allotted to the training mission. The Infantry Board which conducts operational tests of material uses range areas jointly with the training organizations. Additionally, it does have a small instrumented area set aside for its exclusive use. Instrumentation is designed to collect data on the operational characteristics on the man/weapon system as opposed to the weapon itself.

The USAIB at Ft. Benning is the only organization whose mission is operational testing.

Ft. Benning is primarily concerned with its training mission, but as the combat developer to the infantry it is involved with experiments and testing of concepts and material. Scheduling for range and troop support for tests is a routine matter.

The USAIB's major testing responsibilities include:

1. Equipment and ancillary items to be used by infantry units for firepower, target acquisition, ground surveillance, fire control, and ground mobility.
2. Field-type clothing, equipment, and rations of individuals.
3. Antipersonnel mines and related equipment.
4. Chemical, biological, and radiological equipment for individuals.
5. Participation in operation testing as directed.
6. Plan, direct, and control a program in test methodology, test instrumentation, and test facilities needed to support current and future test requirements within assigned missions.

There are few commitments at Ft. Benning. Presently there are no ROTC programs and only weekend firings by National Guard and Reserve units. This weekend firing takes place at a yearly rate which would probably cause few schedule conflicts.

Presently there are no special operational restrictions governing users of ranges and test areas.

Operations of Army or Air Force aircraft is allowed and performed in many test areas. Forestry work and hunting are low priority items and normally do not interfere with range usage. No radiological environmental test capability exists at the Center.

C-5.3.1 Farnsworth Range. This is a "known distance" rifle range separated from the USAIB "Sandy Patch" test area by a paved highway. The 500-meter length, flat surface, and convenient location result in frequent use of this facility for other than small arms tests. The facility is not instrumented; however, instrumentation and data links to the computer can be easily installed. Farnsworth Range is used frequently for small methodology and instrumentation experiments.

C-5.3.2 Fournier Complex. This complex, located in the northwestern portion of Nolan Range is 10 Km by 15 Km in size. Used primarily as a vehicle cross-country test range with 12 surveyed points, other types of testing are possible. Six surveyed mortar firing points are available. The terrain is rolling hills with light cover and few swampy areas. No instrumentation is installed in this area.

C-6 NAVAL WEAPON CENTER.

C-6.1 Physical Characteristics.

The Naval Weapons Center (NWC) at China Lake, California, is the primary research, development, and test activity of the Naval Material Command. Located about 160 miles northeast of Los Angeles, the NWC is an integrated military/civilian complex of about 1,092,000 acres.

The yearly average rainfall at the Center is 3 inches. Wind gusts with peak velocities exceeding 40 miles per hour occur on the average of 35 days each year. The area surrounding the Naval Weapons Center is desert. Various dry lakebeds are scattered throughout the Center.

Mountain ranges with peaks up to 7,500 feet above sea level skirt the Center's western boundary. The eastern portion of the NWC is generally mountainous with peaks reaching 8,300 feet above sea level. The COSO Military Target range is located on a broad mountainous plateau in the northwest corner of NWC. The range covers an area of approximately 19,200 acres and contains various military targets at elevations of 1,000 to 8,000 feet in rolling terrain, covered with pinon pine, juniper trees, and brush.

The complex consists of two main areas. China Lake proper, the largest of the two areas, is roughly rectangular (26 miles east to west, and 42 miles north to south), and contains 640,000 acres. The second area under NWC control is located 25 miles to the southeast of China Lake and contains approximately 512,000 acres.

C-6.2 Support Capabilities.

C-6.2.1 Military Units. The Naval Air Facility at Armitage Field provides air support for NWC's development and test programs.

The Supply Department provides logistical support of all.

C-6.2.2 Power and Communications. All major test ranges have adequate power. Portable power generators are available at remote locations.

The communications facility comprises both wire and radio channels that connect the test control center at each range with its instrument sites and vehicles. Most communications are handled via an FM two-way radio network.

The system presently encompasses over 450 units in fixed, portable, and mobile stations. Communication units are available for temporary installation in special instrumentation packages used for particular test programs.

Ground-to-aircraft communications are provided in the test control centers and at radar plotting boards via UHF transmission.

C.6.2.3 Range Facilities. The Guided Missile Range is used primarily for testing of all types of air and ground launched weapons such as guided missiles, rockets, and unguided ordance. It is heavily instrumented downrange with electronic and optical instrumentation, augmented with wide variety of mobile instrumentation, and has complete telemetry and timing stations.

Aircraft Ranges consist of B-range, C-range, and the Coso military target range, collectively covering approximately 450 square miles over western half of Naval Weapons Center. Instrumentation is designed around the basic mission of each range, but ranges are not restricted to particular missions. Basically the following applies to all three ranges:

1. Each range has its own control tower or center and is equipped with a varying quantity of radars, cameras, timing instrumentation, communications networks, impact-spotting stations, and a plotting center.

2. A wide variety of targets and target areas is available; special targets can be constructed or provided when required. HE tests are restricted to specific target areas on B and C ranges unless complete recovery of duds can be assured.
3. Support facilities are available for processing film, reducing photographic and telemetered data, and measuring atmospheric phenomena.

B-Range is used primarily for developmental testing of conventional ordnance items, air-to-ground missiles, and bomb-director systems that require extensive instrumentation and camera coverage.

C-Range is used for tests needing less extensive instrumentation coverage but requiring immediate information on impacts and flight path profiles. Its primary mission is the development of flight tactics by VX-5 and the training of Fleet pilots in delivery of both conventional and special weapons, and conducting operational evaluation tests for Operational Test and Evaluation Force squadrons.

Coso Military Target Range is maintained as nearly as possible in its natural state. Presentation of targets in their natural setting provides realistic environmental conditions for development of specific weapons and weapon systems. Instrumentation is limited, relying primarily on voice communications, radar, and impact spotting. Various military targets are strategically located to simulate tactical conditions.

C.6.2.4 Instrumentation. The NWC is heavily instrumented with cinetheodolites and cameras for TSPI of ground and airborne objects. TSPI of multiple objects in a single area is extremely limited, however, as the main effort is to obtain complete records on the time history of missile flights, explosions, etc. The same could be said for radar coverage which is excellent for single airborne objects but has little capability to record or control multiple objects.

MIDAS is a trajectory, miss-distance, impact-location measurement system that can track two airborne vehicles simultaneously. There are three MIDAS sites at NWC. MIDAS uses electronic interferometers to

measure phase differences of RF signals received at antenna pairs from airborne transmitters. Signal sources are telemetry transmitters, normally installed in developmental missiles, and CW signal sources specially installed in target aircraft.

Timing services are provided routinely, usually as specified in the experiment specifications (ES) issued by the Scheduling Office. Special arrangements are seldom necessary. Timing data are transmitted 24 hours a day, primarily in IRIG-B format. They are transmitted by microwave link from the central timing station in the G-1 test control building to the main timing transmitter station on B Mountain, where the microwave data are received and processed. Timing is then retransmitted for use throughout the Center. A pulse code modulation (PCM) timing system augments the IRIG system for the control of instrumentation at downrange locations.

TV cameras are mounted on mobile tracking mounts, radars, or at fixed installations. The NWC can perform all the standard black and white and color motion picture photography.

The four main types of radio telemetry facilities at the NWC missile ranges include FM/FM, PAM, PCM, or PDM/FM. The telemetry building is headquarters for these facilities. Facilities for communicating with and monitoring launcher control, range, and other critical areas are available to the test conductor in the flight observer areas of the telemetry building. The facility also contains equipment for observing real-time data and making magnetic tape and oscillograph records.

In addition to the fixed stations, mobile stations consisting of antenna preamplifier, receivers, and two tape recorders, are available for downrange operation or for backup of the fixed stations. The magnetic tape record can be played back in the telemetry building for presentation of the data on oscillographic film or paper.

NWC has a limited IR measurement and monitoring capability, and no CBR instrumentation.

C-6.2.5 Data Processing. The NWC Computer Center's UNIVAC 1108 is located in Wing 5 of Michelson Laboratory. Various remote terminals are located throughout Michelson Laboratory, and in other laboratories at NWC.

Telemetry data recorded on magnetic tape are normally duplicated immediately after a test or, in the case of PDM and some FM/FM data, can be digitized directly for processing through the 1108.

C-6.3 Special Capabilities and Limitations

The mission of NWC is to conduct a program of warfare analysis, research, development, test evaluation, systems integration, and fleet engineering support in naval weapons systems, principally for air warfare, and to conduct investigations into related fields of science and technology.

NWC operates more than 25 test ranges and facilities primarily in support of the Center's R&D programs. These facilities have been developed over the years in response to in-house needs arising from assigned weapon R&D projects, as well as to meet the testing requirements of activities external to the Center.

The Naval Weapons Center has many outstanding features which make it a candidate for Army OT&E. These features are large landscape, extensive range instrumentation, drone capability, electronic warfare (EW) capability, command, control and communication, and a realistic target environment.

The Center's test facilities and ranges are not all in continuous operation, fully staffed and manned. Many of these facilities overlap, sharing common airspace, ground space, and instrumentation, as well as work crews.

The test effort occurs in the following general categories:

1. Flight and firing tests of conventional/tactical munitions including air-to-air, air-to-surface, and surface-to-surface.

2. Flight tests of aircraft armament and fire control systems, and electronic countermeasures systems and tactics development.
3. Various specialized tests, including high-speed track tests, CVA configuration control tests, aircraft combat damage survivability tests, and tests of lasers and electro-optical sensors.
4. Tactics development.

NWC has no recurring commitments. The only current special operating restriction is to keep all hazardous operations to that airspace over NWC property.

The restricted airspaces under the control of NWC are designated R-2505 and R-2524 and extend from the surface to unlimited altitude. An extension of R-2505, designated as R-2506, is restricted from the surface to 6,000 feet MSL in order to provide for low-altitude run-in to certain of the NWC ranges.

C-7 EGLIN AIR FORCE BASE.

C-7.1 Physical Characteristics.

The Eglin Air Force Base complex is in northwest Florida with more than 720 square miles of land test ranges and facilities. The land complex, consisting of the Main Base and six auxiliary airfields measures 51 miles across and 19 miles north to south (see Figure C-6). Areas where ground operations have normally taken place are highlighted by shading. Area "B," surrounding the Rock Hill Landing Zone, is in the same general location as the former "underbrush" range used extensively during the SEA conflict to develop new tactics and sensor usage against representative target and ground environments. There are two helicopter landing pads in this area, and it has been used as an assault landing strip.

Some of the land is flat and some gently rolling; much is covered with woods and scrub vegetation. Frequent heavy rain occurs during winter, occasionally lasting several days. There are occasional morning fogs, but freezing weather is almost nonexistent.

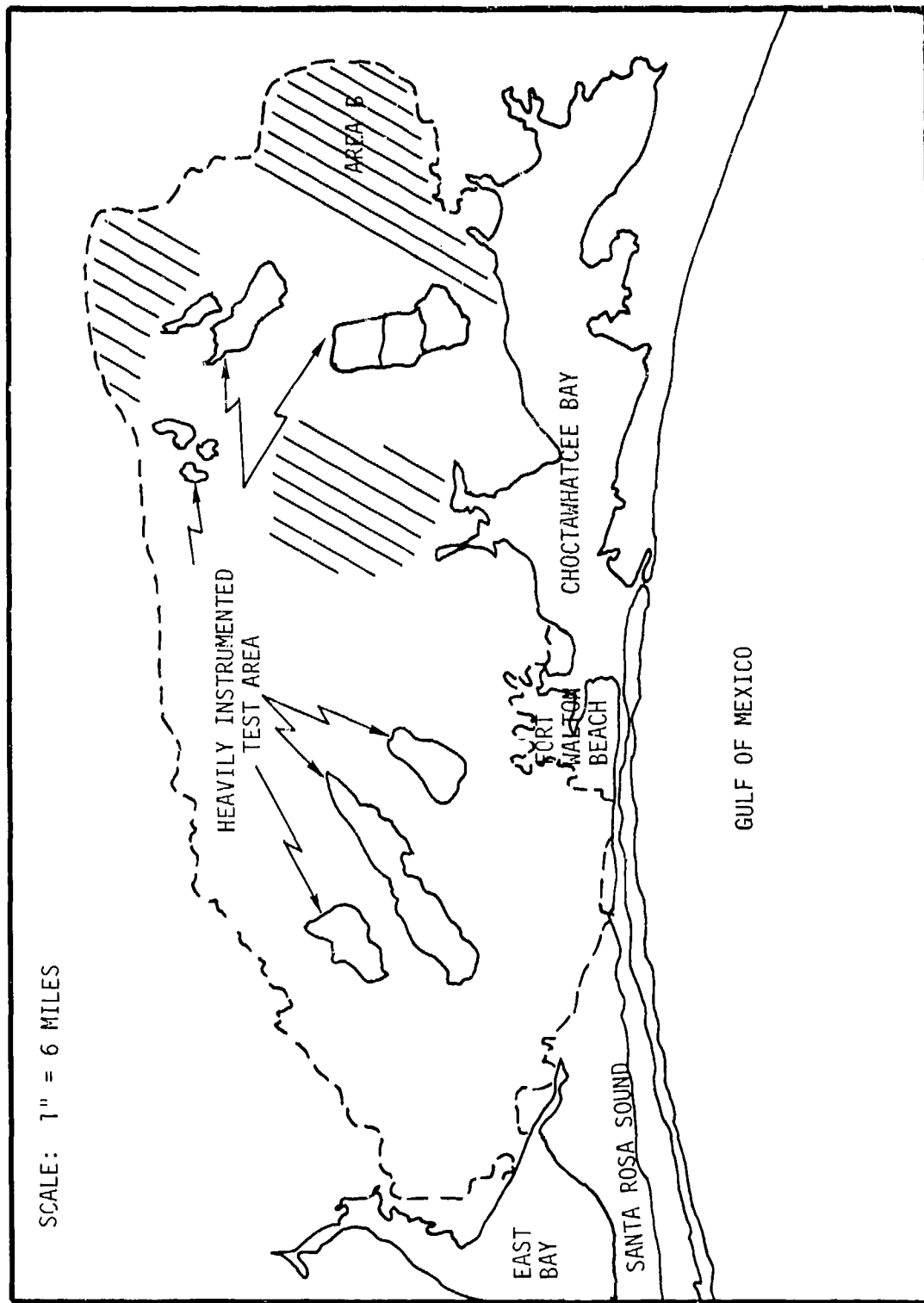

Figure C-6. The Eglin AFB test complex.

C-7.2 Support Capabilities.

C-7.2.1 Military Units. The units listed below as tenants at Eglin AFB serve as some indication of the base's overall ability to support testing.

1. Air Ground Operating School (Army)
2. Army Ranger School (Field 6)
3. Headquarters, Armament Development and Test Center (AFSC)
4. 3246th Test Wing (AFSC)
5. 3201st Air Base Group (AFSC)
6. USAF Regional Hospital (AFSC)
7. 39th Aerospace Rescue and Recovery Wing (MAC)
8. Detachment 10, 6th Weather Wing (MAC)
9. Tactical Air Warfare Center (TAC)
10. Special Operations Wing, Special Operations Force (TAC)
11. 33rd Tactical Fighter Wing (TAC)
12. 557th Civil Engineering Squadron (TAC)
13. 919th Tactical Airlift Group Reserve (TAC)
14. AGOS (Air-Ground Operations School) (TAC)
15. 20th Surveillance Squadron (ADC)
16. 1972nd Communications Squadron (AFSC)

Extensive aircraft (fixed wing) and avionic maintenance facilities are available.

C-7.2.2 Instrumentation. Planned large-scale instrumentation improvements include:

1. Multilateral time-space positioning systems, over both land and water.
2. Improved L- and S-band digital telemetry systems.
3. Improved time correlation between telemetry and multilateral systems.

Range B-70 has an AN/TPX-42 (L-band) radar mounted on a 120 foot tower to scan the whole range. While intended primarily for use on airborne elements, the AN/TPX-42 may also be used to locate ground elements on the range. Up to 128 individual objects can be identified.

Several L-band radars may have a limited capability for tracking through foliage.

The primary tracking radar subsystem is located at three sites along the Gulf (A-3, A-20, D-3) and generate object position data in digital and analog form. The radars used are six AN/FPS-16 (C-band) and three AN/MPS-19 (S-band).

There are 35 fixed and 3 mobile cinetheodolites, of which about half are digital and half are analog systems.

A system known as DIGIDOPS is in use for relative position (miss distance) data. A vector system is under development.

Twenty-one Amament Development and Test Center (ADTC) test sites are equipped with Inter-range Instrumentation Group (IRIG) Standard Time Code Generators, each independently synchronized to LORAN-C transmitted signals. IRIG time is also transmitted from Eglin Main by VHF radio, servicing approximately 120 land receivers and 22 airborne receivers. The radio transmission also includes shutter pulses and timing information for use on Contraves cameras.

There are ground TV installations at Eglin AFB used for various missions including:

1. Ground RPV control.
2. Lethal munitions surveillance and handling.
3. Reception, presentation, and recording TV signals from aircraft.

The uses of motion picture equipment at ADTC include:

1. Acquisition of time-space-position data through the use of cinetheodolites.
2. Engineering sequential photography through the use of a wide variety of camera/lens combinations, including ultra-high speed cameras with frame rates to 2.4×10^6 / sec (Beckman-Whitley Model 189). Mobile trackers with camera mounts are available.

3. Documenting photography, using numerous types of equipment, including the mobile trackers also used for engineering sequential photography.

The telemetry system currently in use at Eglin is the CORTS (System 469L). This is an L- and S-band (1435 MHz and 2200-2300MHz) FM/FM, PAM, and PDM system.

Radio frequency monitoring capabilities include a fixed installation at Site A-6 and a semi-mobile van at Site D-3, each with a frequency coverage from 15 kHz to 10.75 GHz. There is also a fixed site at B-4B with frequency coverage from 20 Hz to 18 GHz and a mobile chase van.

The Electromagnetic Test Environment (EMTE) generates a "hostile" electromagnetic environment, using radars and radar simulators.

C-7.2.3 Data Processing. The responsibilities of the ADTC Computer Sciences Laboratory include data storage and retrieval services.

Information can be extracted from film and oscillographs and automatically punched into cards using various types of reading equipment.

Telemetry data is processed by the Telemag Facility. The data may have been recorded on tape on the test vehicle, telemetered to the ground and recorded, or it may be fed directly to Telemag.

The Computer Sciences Laboratory has the following computers:

<u>Type</u>	<u>Primary Function(s)</u>
CDC 6600 (2)	Primary system for all ADTC scientific computing
PDP 15	The primary telemetry computer, handles PAM, DPM
EAI 681/693	Analog computer with hybrid interface, feeds PDP 15
SEL 810A	Used to slave radars and theodolites, and predict impacts
Burroughs 3500	Base management support computer
IBM 360/65	General purpose computer

C-7.3 Special Capabilities and Limitations.

Eglin AFB plays host to the U.S. Air Force Armament Development and Test Center (ADTC) and the Tactical Air Warfare Center (TAWC). These two organizations possess the primary local capability to support tests. In the past, testing at Eglin AFB has been primarily of Air Force systems, with limited joint Service and other Service system testing. Such testing includes: non-nuclear munitions and missiles, EW systems, command and control systems, target systems, intrusion interdiction sensors, and tactical air warfare techniques. The Special Operations Wing, Special Operations Force, located at Field 9, may be able to assist in special operations testing.

The base has no recurring ROTC or reserves commitment. Hunting is permitted on base during the latter halves of November and December. Eglin AFB is not suitable for extensive tank maneuvers because of the danger of damage to commercially harvested trees.

Each individual test area operates independently through a range control central. Integration of one or more of the test areas can be scheduled and is accomplished by means of land line and radio communication.

The Florida ranger camp has used the western area of the Eglin reservation for ground training maneuvers. The 3rd Ranger Battalion trains students in counter guerrilla operations. The only restriction on maneuvers in the western area other than standard central coordination, is that impact areas and threat radar sites must be avoided.

Airspace restrictions over Eglin AFB (see Table C-1) are located over the east and west portions of the reservation, with the central portion of the reservation from north to south left open for commercial operations into the base air terminal.

Table C-1. ADTC airspace restrictions.

<u>Area</u>	<u>Altitude Limits (feet)</u>
R2914, 15, 18, 19	0-50,000
W151, 2, 3, 4,	0-24,000+
W168	Unlimited
W470	Unlimited

No radiological testing is undertaken at ADTC.

C-8 FORT KNOX.

C-8.1 Physical Characteristics.

Fort Knox (Figure C-7) is located about 30 miles southwest of Louisville, Kentucky. It is the home of the Armor Center and School. Its tenant activities include the Army Maintenance Board, Army Medical Research Lab, and the TECOM Armor and Engineer Board. Fort Knox comprises 110,300 acres.

The terrain varies from low, rolling, wooded hills to sharp escarpments and densely wooded areas. Water areas include several lakes and accessibility to the Ohio River.

Normally, in the Fort Knox area, precipitation is evenly distributed throughout the year, with fall the driest season. During the winter, there may be periods ranging from several days to more than a week when the temperature remains almost continuously below freezing, and the ground is frozen to a depth sufficient to support a tank.

C-8.2 Support Capabilities.

C-8.2.1 Military Units. The following list of Army units presently located at Fort Knox will serve to provide partial insight to the basic ability and types of support that can be obtained by an outside user.

1. U.S. Army Armor School
2. U.S. Army Armor and Engineer Board (USAARENBD)
3. Armor School Support (includes armored, infantry, engineering, and aviation units)

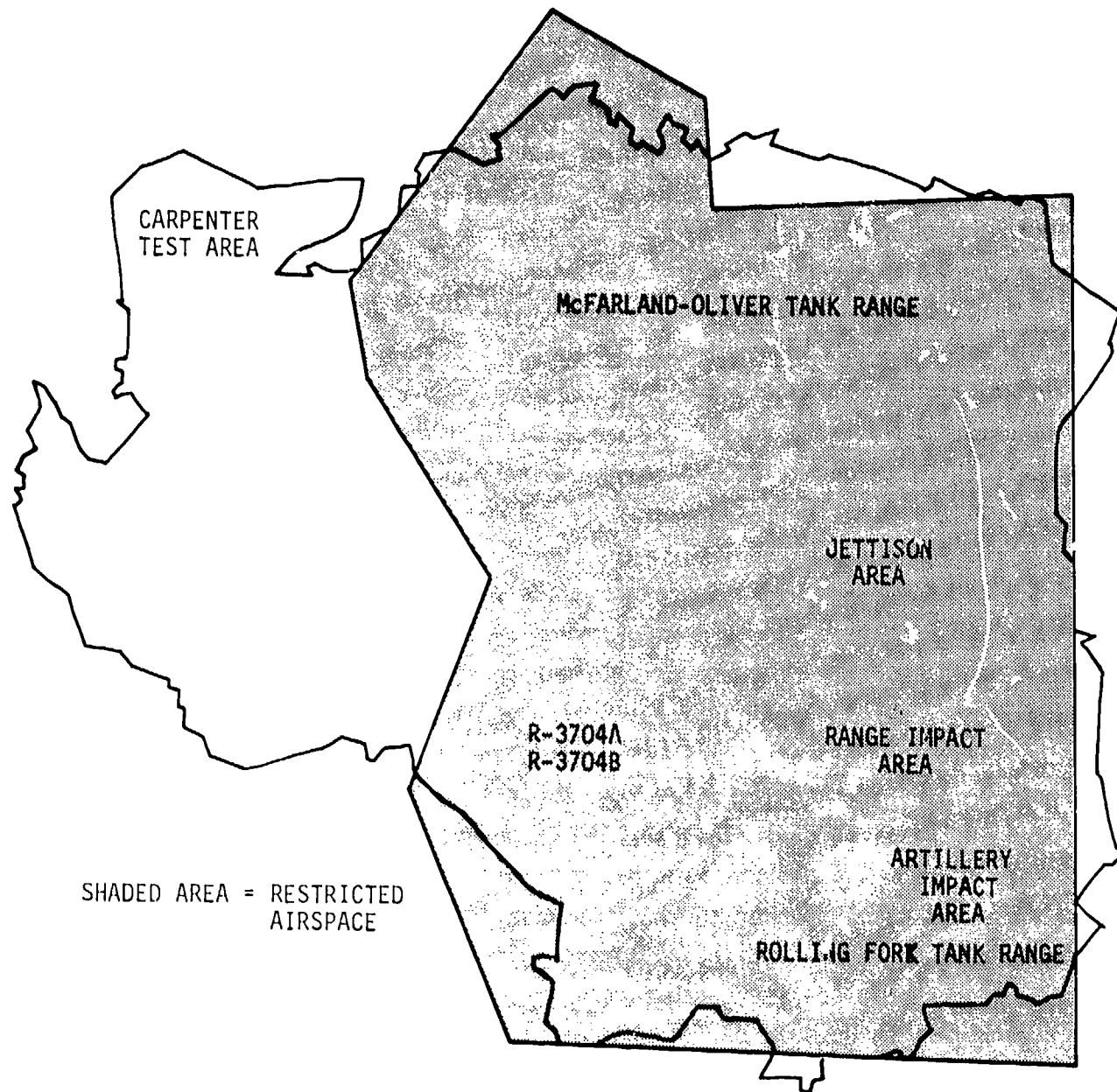

Figure C-7. Fort Knox landspace, showing restricted airspace.

C-8.2.2 Power and Communications. Mobile generators for electrical power are available both at the USAARENBD and Armor Center. Commercial electrical power, 115 volts AC-60 cycle, is available at most ranges. Some ranges are believed to have 220 volt AC capability.

All communications used by the USAARENBD, Armor Center, and range installations are standard military equipment except for a few commercial radios operating on military frequencies. The Board uses both man portable and/or vehicle mounted radios of various types on a loan basis as needed for the majority of their requirements. Landlines for telephones are installed on most ranges.

C-8.2.3 Instrumentation and Data Processing. A position location system (PLS) by Motorola is used to observe and record (on magnetic tape) the positions of up to sixteen vehicles. The PLS uses a base station, repeaters, and mobile battery operated transponders. The PLS uses time differencing (accuracy \pm 3 meters advertized). The PLS has real time scope display. IRIG time can be imposed on the record.

A video automatic target tracking system is in use. The system can track a single moving target by contrast difference.

Several movie and still cameras with IRIG time are in use. Also, there are several vehicle mounted remote control video cameras and one video telemetry link with more planned.

C-8.2.4 Data Processing Computer data processing is currently done off post. A dedicated PDP-1160 or equivalent is planned for 1979.

C-8.3 Special Capabilities and Limitations.

The mission of the Fort Knox facility is to control, train, and provide administrative and logistical support for all units assigned, or attached, to operate the U.S. Army Armor School and Training Center, and to furnish administrative and logistical support to all units and activities (including the U.S. Army Armor and Engineer Board) tenanted at Fort Knox.

The facilities and range areas of Fort Knox are oriented primarily toward the training mission. Of the more than 100,000 acres

within the reservation, some 6,400 are allotted to the Armor and Engineer Board for vehicle testing. The Board is also allotted a 2,000-meter firing range.

The USAARENBD is the only organization located at Fort Knox whose mission is operational test and evaluation. Ft. Knox is primarily concerned with its training mission, but as the combat developer of armor it is involved with experiments and tests of concepts and material. Scheduling for range and troop support for tests is a routine matter.

The USAARENBE major testing capabilities include:

1. Weapons - direct fire cannon class armament
2. Munitions/Demolitions - conventional armor-defeating antipersonnel/antimaterial, screening-type munitions, demolition kits, and cratering charges.
3. Tank-Automotive - tanks and associated tracker-type combat vehicles
4. Communications equipment or components
5. Missiles - ground-to-ground and air-to-ground
6. Engineer Equipment - all classes of engineer equipment for the Field Army
7. General Equipment - POL dispensing, handling, transporting equipment, marine and transportation equipment, industrial equipment and field service equipment
8. Night Vision Equipment - all classes of material employed for illumination, observation, and detection
9. Nuclear/Biological/Chemical Equipment - atomic demolition munitions, radiation detection equipment and CB protective shelters (simulated)
10. Helicopters, Attack - associated armament systems.

Annually, in the summer months, Fort Knox hosts ROTC and Reserve units. These reserve units utilize large amounts of range and test area during their stay. This usage plus normal school training makes availability of these ranges and areas relatively restricted during the summer months.

Presently there are no special operational restrictions governing users of ranges and test areas. There are presently no easements in effect for any of the test ranges or areas. Forestry work, and hunting are low priority items and do not normally interfere with range usage.

C-9 CAMP BULLIS.

C-9.1 Physical Characteristics.

Camp Bullis is located 7 miles north of San Antonio, Texas, and is part of Fort Sam Houston Military Reservation. Total area available is 28,000 acres, but test facilities cover 1,700 acres.

Some terrain has been cleared others have dense forest. Summers are very hot, and activity is usually suspended by early afternoon.

C-9.2 Support Capabilities.

The capability of Camp Bullis to support testing resides mainly in the existing simulated secure facilities, weapons and simulated artillery, vehicles (including APC's), and large numbers of security personnel at various stages of training.

Instrumentation and data processing facilities are nonexistent. Power is available at most test sites. Communications would have to be established by the test team, as existing jeep radio communications are inadequate.

C-9.3 Special Capabilities and Limitations.

The mission of Camp Bullis is to provide training to Air Force security forces. About 9,000 students are trained here each year. Training is as realistic as possible for an uninstrumented facility, and features force-on-force actions with blank ammunition and artillery simulators. Training scenarios are generally hostile penetration of a secure facility, with training instructors playing aggressors and umpires.

The simulated nuclear storage site, aircraft parking, site, and air base complex would be excellent props for test purposes. However, any testing would have to complement (and not impede) the year around training mission at Bullis. Training facilities include:

1. Simulated nuclear storage site (tower, 2 shacks, 9 bunkers, 6 pill box, 2 wire fences, many light poles, area approximately 200 m x 500 m.)
2. Simulated fuel storage site.
3. Simulated missile control site (minute man, 60% scale).
4. Simulated missile launch site (minute man, 60% scale).
5. Simulated aircraft parking ramp.
6. Simulated air base complex. (One and two story metal buildings--the buildings were not functional. No electricity. Internal studs were covered with target cloth.)
7. Various rifle ranges.
8. Hand grenade range.
9. Live fire exercise area.

Training is conducted both day and night, but generally not on weekends. All roads in the training area are dirt. No chemicals such as CS or CN can be used due to environmental impact.

Testing at Bullis may be complicated slightly by the situation of having an Air Force training facility on an Army reservation. C-10

EUROPEAN TEST FACILITIES.

There are no European test ranges under the direct control of U.S. Forces. It would be difficult or impossible to conduct meaningful tests or exercises without involving NATO. Near term testing in Europe does not appear feasible or even prudent.

U.S. Forces do have control over three major training areas in the FRG and access to others. Direct control is exercised over Grafenwoehr, Hohenfels, and Wildflecken. U.S. Forces use the German controlled Baumholder Range about half the available time.

The U.S. Army's major training area (MTA) headquarters is located at Grafenwoehr, near Nurnberg. The headquarters conducts, under USAREUR supervision, an annual planning conference in which all range schedules are confirmed. The major tank and artillery ranges are at Grafenwoehr.

Hoenfels, also located near Nurnberg, is used primarily for infantry maneuver training up to battalion scale. The topography is deep wooded valleys surrounding a high, treeless plateau.

Wildflecken, near Fulda, is mountainous with heavy snowfall. All types of small scale training are conducted here.

Special tests can be conducted in Europe. For example, the joint Army/Air Force test of special sensory equipment was conducted at Hohenfels during 1971-72.

All MTA's have restricted airspaces below 18,000 feet. There are no installed or mobile power sources anywhere. Telephone and FM radio nets are generally available. Instrumentation and data processing equipment is mostly nonexistent.

There are a number of other training and test areas under the control of U.S. allies, and some smaller (possibly U.S. controlled) areas. These collective areas include Grating, Meppen, Todendorf, Lichenau, and Holtern. Nothing is presently known concerning the potential for testing at these areas.

APPENDIX D
LIST OF ACRONYMS

AAF	Army Air Field
ADC	Air Defense Command
ADCS	Automatic Data Collection System
ADM	Atomic Demolition Munition
ADPS	Automatic Data Processing System
ADTC	Armament Development and Test Center
AFSC	Air Force Systems Command
APC	Armored Personnel Carrier
ASP	Ammunition Supply Point
ASR	Approach Surveillance Radar
A/V	Audio Visual
BCC	Battery Control Center
BISS	Base and Installation Security System
BMD	Biomedical Program
BPD	Basic Portable Device
C ²	Command for Control
C ³ I	Command, Control, Communications and Intelligence
CBR	Chemical, Biological, Radiological
CDEC	Combat Developments Experimentation Command
CPU	Central Processor Unit
CRT	Cathode Ray Tube
CSC	Computer Science Corporation
DARS	Data Acquisition and Recording System
DBA	Data Base Administrator
DBM	Data Base Management
DBMS	Data Base Management System
DF	Direct Fire
DFS	Direct Fire Simulator
DMO	Data Management Organization

DMP	Data Management Plan
DMS	Data Management System
DNA	Defense Nuclear Agency
DNA-FC	Defense Nuclear Agency-Field Command
DOD	Department of Defense
DRL	Data Requirements List
EMI	Electromagnetic Interference
EMTE	Electromagnetic Test Environment
EUCOM	European Command (US)
EW	Electronic Warfare
FADAC	Field Artillery Digital Automatic Computer
FDC	Fire Director Center
FHL	Fort Hunter-Liggett
FIST	Fire Support Team
FM	Frequency Modulation
FRG	Federal Republic of Germany
GDP	General Defense Position
HLMR	Hunter-Liggett Military Reservation
HP	Hewlett-Packard
ID	Identification
IDF	Indirect Fire
IEP	Issue Evaluation Plan
IR	Infrared
IRIG	Intra Range Instrumentation Group
LOS	Line of Sight
MAC	Military Airlift Command
MCS	Multiple Computer System
MEP	Master Evaluation Plan
MOE	Measure of Effectiveness
MP	Military Police
MTA	Major Training Area
NATO	North Atlantic Treaty Organization

NWC	Naval Weapons Center
OPORD	Operation Order
OT&E	Operational Test and Evaluation
PAILS	Projectile Airburst and Impact Locating System
PAM	Pulse Amplitude Modulation
PCM	Pulse Code Modulation
PDM	Pulse Duration Modulation
PL	Position Location
PLS	Position Location System
PMP	Program Management Plan
PRRS	Position Reporting and Recording System
QC	Quality Control
QL	Quick Look
R&D	Research and Development
RF	Radio Frequency
RMS	Range Measuring System
ROTC	Reserve Office Training Corps.
RS	Recording System
RT	Real Time
RTCA	Real Time Casualty Assessment
S ²	Survivability and Security
SASP	Special Ammunition Supply Point
SOP	Standard Operating Procedure
SP	Self Propelled, Security Police
SPSS	Statistical Package for the Social Sciences
SSL	Scientific Support Laboratory
SST	Safe Secure Trailer
STS	Stockpile to Target Sequence
T&E	Test and Evaluation
TAC	Tactical Air Command
TAWC	Tactical Air Warfare Center
TCATA	TRADOC Combined Arms Test Activity

TECOM	Test and Evaluation Command
TI	Texas Instruments
TNF	Theater Nuclear Force
TNF OP	Theater Nuclear Force Operational Process
TNF S ²	Theater Nuclear Force Survivability and Security
TRADOC	Training and Doctrine Command
TSPi	Time Space Position Instrumentation
TV	Television
USAARENBD	U. S. Army Armor and Engineer Board
USAFABD	U. S. Army Field Artillery Board
ASAFAS	U. S. Army Field Artillery School
USAFE	U. S. Air Force - Europe
USAIB	U. S. Army Infantry Board
USAREUR	U. S. Army - Europe
WESS	Weapons Engagement Scoring System

DISTRIBUTION LIST

DEPARTMENT OF DEFENSE

AFSOUTH
ATTN: U.S. Documents Officer

Armed Forces Staff College
ATTN: Reference & Technical Services Branch

Assistant Secretary of Defense
International Security Affairs
ATTN: Policy Plans & NSC Affairs
ATTN: P & P Nuclear Policy
ATTN: NATO Nuc. Policy Div.
ATTN: European & NATO Affairs

Assistant Secretary of Defense
Comm., Cmd., Cont. & Intell.
ATTN: Surveillance & Warning System
ATTN: Combat Support
ATTN: Intelligence Systems

Assistant Secretary of Defense
Program Analysis & Evaluation
ATTN: Strategic Programs
ATTN: General Purpose Programs
ATTN: Regional Programs

Assistant to the Secretary of Defense
Atomic Energy
ATTN: Executive Assistant

Command & Control Technical Center
ATTN: C331/NCPS

Commander-in-Chief
U.S. European Command
ATTN: J-5
ATTN: J-3
ATTN: J-6
ATTN: J-2
ATTN: J-417-LW
ATTN: J-5NPG
ATTN: J-2-ITD

Commander-in-Chief, Pacific
ATTN: J-54
ATTN: J-6
ATTN: J-2
ATTN: J-3

Defense Advanced Rsch. Proj. Agency
ATTN: TTD

Defense Communications Agency
ATTN: Director

Defense Communications Engineer Center
ATTN: R-123

Defense Intelligence Agency
ATTN: RDS-3C
ATTN: DT-1

Defense Nuclear Agency
ATTN: OASO
ATTN: STSS
4 cy ATTN: TITL

DEPARTMENT OF DEFENSE (Continued)

Field Command
Defense Nuclear Agency
ATTN: FCP-FCPRT
ATTN: FCC-FCRRK
ATTN: FCPR

Field Command
Defense Nuclear Agency
Livermore Division
ATTN: FCPRL

Field Command
Defense Nuclear Agency
Los Alamos Branch
ATTN: FCPRA

Intelligence Center, Pacific
ATTN: I-3

Interservice Nuclear Weapons School
ATTN: TTV

Joint Chiefs of Staff
ATTN: J-5, Nuclear Division
ATTN: J-3
ATTN: SAGA

Joint Strat. Tgt. Planning Staff
ATTN: JL
ATTN: JP

Secretary of Defense Representative
Mutual & Balanced Force Reduction
ATTN: R. Clarke

National Defense University
ATTN: NWCLB-CR

Director
Net Assessment
ATTN: DIR, A. Marshall

U.S. Forces, Korea
ATTN: CJ-P-G
ATTN: DJ-AM-SM

U.S. National Military Representative
SHAPE
ATTN: U.S. Documents Officer for OPS
(Nuc. Plans)

Undersecretary of Defense for Rsch. & Engrg.
ATTN: Strategic & Space Systems (OS)

DEPARTMENT OF THE ARMY

Deputy Chief of Staff for Ops. & Plans
Department of the Army
ATTN: DAMO-RQS
ATTN: DAMO-SSP
ATTN: DAMO-SSN, LTC Cooper
ATTN: DAMO-SSW
ATTN: DAMO-NCC, V. Fenwick
ATTN: DAMO-ZD, C. Williams

DEPARTMENT OF THE ARMY (Continued)

Deputy Chief of Staff for Rsch. Dev. & Acq.
Department of the Army
ATTN: Advisor for RDA Analysis, M. Gale
ATTN: DAMA-CSS-N, W. Murray
ATTN: DAMA-CSM-N

Deputy Undersecretary of the Army
ATTN: Mr. Lester (Operations Research)

Electronics Tech. & Devices Lab.
U.S. Army Electronics R&D Command
ATTN: DELEW, R. Freiberg

Harry Diamond Laboratories
Department of the Army
ATTN: DELHD-N-RBA, J. Rosado
ATTN: DELHD-N-CO, J. Ramsden
ATTN: DELHD-N-TD, W. Carter
ATTN: DELHD-N-P, F. Balicki

Measurement ECM & Support Technical Area
Department of the Army
ATTN: DRSEL-WL-M-M

Office of the Chief of Staff
Department of the Army
ATTN: DACS-DMO

U.S. Army Air Defense School
ATTN: ATSA-CD-SC

U.S. Army Armament Research & Development Command
ATTN: DRDAR-LCN-E

U.S. Army Ballistic Research Labs.
ATTN: DRDAR-BLV

U.S. Army Comb. Arms Combat Dev. Acty.
ATTN: AT 2LCA-DLT

U.S. Army Concepts Analysis Agency
ATTN: CSCA-WGG

U.S. Army Elct. Warfare Lab. (ECOM)
ATTN: DELEW-M-FM, S. Megeath

Commander-in-Chief
U.S. Army, Europe and Seventh Army
ATTN: DCSOPS-AEAGD-MM
ATTN: DCSOPS-AEAGC-O-N
ATTN: DCSOPS-AEAGB

U.S. Army Forces Command
ATTN: AFOP-COE

U.S. Army Materiel Dev. & Readiness Cmd.
ATTN: DRCDE-DM

U.S. Army Materiel Sys. Analysis Activity
ATTN: DRXSY-S
ATTN: DRXSY-DS

U.S. Army Missile Command
ATTN: DRSMI-YDR, Foreign Intelligence Office

U.S. Army Nuclear & Chemical Agency
ATTN: Library for MONA-ZB
ATTN: Library for MONA-SAL

DEPARTMENT OF THE ARMY (Continued)

U.S. Army Ordnance & Chemical Center and School
ATTN: ATSL-CCC-M

U.S. Army TRADOC Systems Analysis Activity
ATTN: ATAA-TDC, J. Hesse

U.S. Army Training and Doctrine Command
ATTN: ATORI-IT-TA

U.S. Army War College
ATTN: AWCI, R. Rogan

V. Corps
Department of the Army
ATTN: AETVFAS-F, P. Reavill

VII Corps
Department of the Army
ATTN: AETSFA-FSE
ATTN: AETSGB-I
ATTN: AETSGB-O
ATTN: AETSGC-O

DEPARTMENT OF THE NAVY

David Taylor Naval Ship R&D Ctr.
ATTN: Code 174/Code 186

Naval Academy
ATTN: Nimitz Library/Technical Rpts. Branch

Naval Material Command
ATTN: MAT-00N

Naval Ocean Systems Center
ATTN: Research Library

Naval Postgraduate School
ATTN: Code 1424

Naval Research Laboratory
ATTN: Code 4108

Naval Surface Weapons Center
ATTN: Code F31
ATTN: Code F32, W. Emberson
ATTN: Code X211

Naval War College
ATTN: Center for War Gaming
ATTN: 12

Naval Weapons Center
ATTN: Code 31707

Naval Weapons Evaluation Facility
ATTN: Code AT

Nuclear Weapons Tng. Group, Atlantic
Department of the Navy
ATTN: Technical Library

Office of Naval Research
ATTN: Code 713

Office of the Chief of Naval Operations
ATTN: OP 604

DEPARTMENT OF THE NAVY (Continued)

Headquarters Marine Corps (Code PL)
Department of the Navy
ATTN: Joint Strategic Branch

Commander-in-Chief
U.S. Atlantic Fleet
Department of the Navy
ATTN: Code J-34
ATTN: Code J-54

Commander-in-Chief
U.S. Naval Forces, Europe
ATTN: N326, R. Thomas

DEPARTMENT OF THE AIR FORCE

Aeronautical Systems Division
Air Force Systems Command
ATTN: XRO/MAR, J. Sherrod

Aerospace Defense Command
ATTN: ADCOM/INA

Air Force Armament Laboratory
ATTN: AFATL

Air Force Weapons Laboratory
Air Force Systems Command
ATTN: SUL
ATTN: NSSB
ATTN: AFWL SA
ATTN: NTN

Assistant Chief of Staff
Studies & Analyses
Department of the Air Force
ATTN: AF/SAMI

Deputy Chief of Staff
Operations Plans and Readiness
Department of the Air Force
ATTN: AFXOXF, R. Linhard
ATTN: AFXOXFM

Deputy Chief of Staff
Research, Development, & Acq.
Department of the Air Force
ATTN: AFRDQSM

Tactical Air Command
Department of the Air Force
ATTN: XPS
ATTN: XPSC
ATTN: DRA

Commander-in-Chief
U.S. Air Forces in Europe
ATTN: XPX
ATTN: XPXX
ATTN: INAT

DEPARTMENT OF ENERGY

Department of Energy
ATTN: OMA, D. Hoover

Department of Energy
ATTN: DOE/ISA

DEPARTMENT OF ENERGY CONTRACTORS

Lawrence Livermore National Laboratory
ATTN: L-9, R. Barker
ATTN: L-9, D. Blumenthal
ATTN: L-21, M. Gustavson

Los Alamos National Scientific Laboratory
ATTN: G. Best

Sandia National Laboratories
ATTN: J. Kaizur
ATTN: Sys. Studies, Div. 1313
ATTN: 1313, T. Edrington

DEPARTMENT OF DEFENSE CONTRACTORS

Advanced Research & Applications Corp.
ATTN: R. Armistead

AVCO Research & Systems Group
ATTN: G. Grant
ATTN: J. Gilmore

Battelle Memorial Institute
ATTN: D. Hamman

BDM Corp.
ATTN: J. Braddock

BDM Corp.
ATTN: T. McWilliams

General Electric Company-TEMPO
ATTN: DASIAC

General Research Corp.
ATTN: H. Schroeder
ATTN: P. Lowry

Hudson Institute, Inc.
ATTN: H. Kahn

Hughes Aircraft Co.
ATTN: H. Ward

JAYCOR
ATTN: E. Almqvist
ATTN: R. Sullivan

JAYCOR
ATTN: S. Brucker

Kaman Sciences Corp.
ATTN: F. Shelton

LFE Corp.
ATTN: M. Nathans

Lockheed-California Co.
ATTN: G. Busch

Mathematical Applications Group, Inc.
ATTN: M. Cohen

Mission Research Corp.
ATTN: D. Sowle

DEPARTMENT OF DEFENSE CONTRACTORS (Continued)

R & D Associates
ATTN: C. MacDonald
ATTN: S. Cohen
ATTN: A. Latter

R & D Associates
ATTN: R. Latter

Rand Corp.
ATTN: W. Jones
ATTN: Library

Santa Fe Corp.
ATTN: D. Paolucci

Science Applications, Inc.
ATTN: J. Martin
ATTN: M. Drake

Science Applications, Inc.
ATTN: W. Layson

SRI International
ATTN: D. Elliott
ATTN: P. Dolan

DEPARTMENT OF DEFENSE (Continued)

Defense Technical Information Center
12 cy ATTN: DD

DEPARTMENT OF DEFENSE CONTRACTORS (Continued)

SRI International
ATTN: W. Berning
ATTN: R. Foster

Systems, Science & Software, Inc.
ATTN: K. Pyatt

Systems, Science & Software, Inc.
ATTN: J. Cane

Technology Service Corp.
ATTN: S. Canby

Tetra Tech, Inc.
ATTN: F. Bothwell

TRW Defense & Space Sys. Group
ATTN: N. Lipner

Vector Research, Inc.
ATTN: S. Bonder