

AD-A088 130

NAVAL AIR DEVELOPMENT CENTER WARMINSTER PA AIRCRAFT --ETC F/6 20/4  
THE EFFECTS ON THE CENTER OF PRESSURE AND THE STATIC MARGIN OF --ETC(U)  
MAY 79 S GREENHALGH  
NADC-80045-60

UNCLASSIFIED

NL

1 of 1  
AD  
AD (99-10)



END  
DATE  
FILMED  
8-80  
DTIC

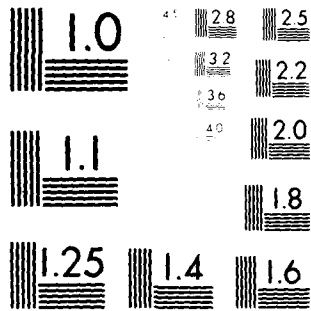

MICROCOPY RESOLUTION TEST CHART  
NBS 1963-A

REPORT NO. NADC-80045-60

② LEVEL II



AD A088130

THE EFFECTS ON THE CENTER OF PRESSURE AND THE  
STATIC MARGIN OF A TDU-34/A TARGET VEHICLE OF  
SIX DIFFERENT NOSE CONE AFTERBODY COMBINATIONS

Samuel Greenhalgh  
Aircraft and Crew Systems Technology Directorate  
NAVAL AIR DEVELOPMENT CENTER  
Warminster, Pennsylvania 18974

10 MAY 1979

FINAL REPORT  
AIRTASK NO. 6306301-001D-OW06100000

Approved for Public Release,  
Distribution Unlimited

DTIC  
ELECTE  
AUG 22 1980  
S D  
B

Prepared for  
NAVAL AIR SYSTEMS COMMAND  
Washington, DC 20361

DDC FILE COPY

80 8 22 011

NOTICES

REPORT NUMBERING SYSTEM - The numbering of technical project reports issued by the Naval Air Development Center is arranged for specific identification purposes. Each number consists of the Center acronym, the calendar year in which the number was assigned, the sequence number of the report within the specific calendar year, and the official 2-digit correspondence code of the Command Office or the Functional Directorate responsible for the report. For example: Report No. NADC-78015-20 indicates the fifteenth Center report for the year 1978, and prepared by the Systems Directorate. The numerical codes are as follows:

CODE	OFFICE OR DIRECTORATE
00	Commander, Naval Air Development Center
01	Technical Director, Naval Air Development Center
02	Comptroller
10	Directorate Command Projects
20	Systems Directorate
30	Sensors & Avionics Technology Directorate
40	Communication & Navigation Technology Directorate
50	Software Computer Directorate
60	Aircraft & Crew Systems Technology Directorate
70	Planning Assessment Resources
80	Engineering Support Group

PRODUCT ENDORSEMENT - The discussion or instructions concerning commercial products herein do not constitute an endorsement by the Government nor do they convey or imply the license or right to use such products.

CAUTION - NATIONAL SECURITY INFORMATION. UNAUTHORIZED DISCLOSURE SUBJECT TO CRIMINAL SANCTIONS.

APPROVED BY:

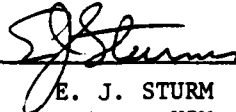
  
 E. J. STURM  
 CDR USN

DATE:

5/27/80

UNCLASSIFIED

SECURITY CLASSIFICATION OF THIS PAGE (When Data Entered)

REPORT DOCUMENTATION PAGE		READ INSTRUCTIONS BEFORE COMPLETING FORM
1. REPORT NUMBER <b>(14)</b> NADC-80045-60	2. GOVT ACCESSION NO. AD-A088430	3. RECIPIENT'S CATALOG NUMBER
4. TITLE (and Subtitle) <b>(6)</b> The Effects on the Center of Pressure and the Static Margin of a TDU-34/A Target Vehicle of Six Different Nose Cone Afterbody Combinations		5. TYPE OF REPORT & PERIOD COVERED <b>(9)</b> Final Report
7. AUTHOR(s) <b>(10)</b> Samuel Greenhalgh		6. PERFORMING ORG. REPORT NUMBER
9. PERFORMING ORGANIZATION NAME AND ADDRESS Naval Air Development Center Code 6051 Warminster, PA 18974		8. CONTRACT OR GRANT NUMBER(s) <b>(13)</b> 201
11. CONTROLLING OFFICE NAME AND ADDRESS <b>(9)</b> WO1-0		10. PROGRAM ELEMENT, PROJECT, TASK AREA & WORK UNIT NUMBERS
14. MONITORING AGENCY NAME & ADDRESS (if different from Controlling Office) <b>(11)</b> WO6100000		12. REPORT DATE 10 May 1979
		13. NUMBER OF PAGES 18
		15. SECURITY CLASS. (of this report) UNCLASSIFIED
		15a. DECLASSIFICATION/DOWNGRADING SCHEDULE
16. DISTRIBUTION STATEMENT (of this Report) Approved for Public Release; Distribution Unlimited		
17. DISTRIBUTION STATEMENT (of the abstract entered in Block 20, if different from Report)		
18. SUPPLEMENTARY NOTES		
19. KEY WORDS (Continue on reverse side if necessary and identify by block number) TDU-34/A Target Static Margin Six Different Nose Cone Afterbody Combinations		
20. ABSTRACT (Continue on reverse side if necessary and identify by block number) Calculations were made to determine the effects on the aerodynamics of six different nose cone afterbody combinations. The highest static stability margin is provided by a short nose cone on the basic "x" fin body without the boat tail afterbody.		

375000 204

**SECURITY CLASSIFICATION OF THIS PAGE (When Data Entered)**

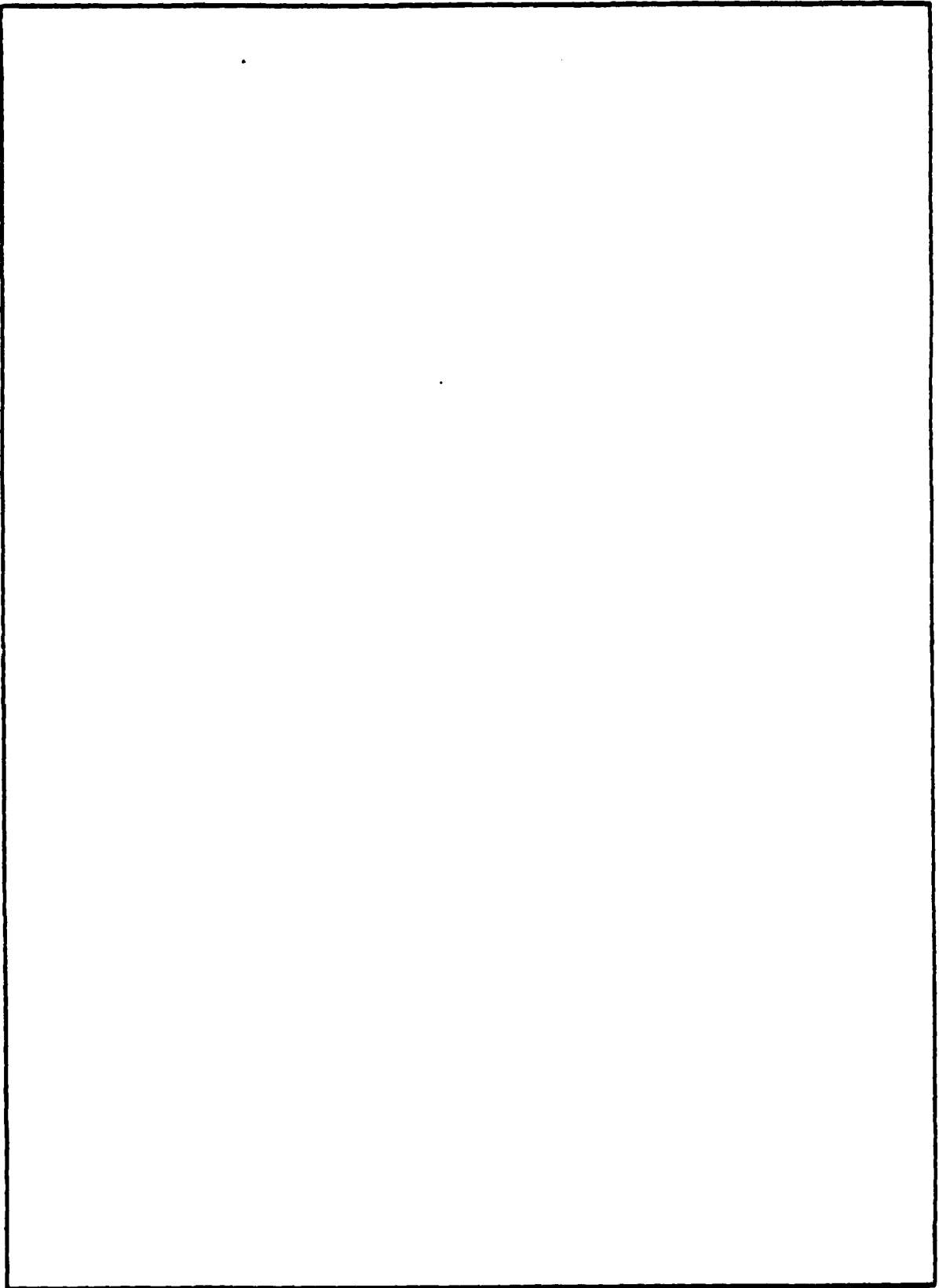

**SECURITY CLASSIFICATION OF THIS PAGE (When Data Entered)**

NADC-80045-60

S U M M A R Y

Calculations were made to determine the effects on the aerodynamics of six different nose cone afterbody combinations. The static stability margin for the six combinations is tabulated. The highest static stability margin is provided by a short nose cone on the basic "x" fin body without the boat tail afterbody.

ACCESSION for		
NIS	Write Section	<input checked="" type="checkbox"/>
DOC	B.H. Section	<input type="checkbox"/>
UNANNOUNCED		<input type="checkbox"/>
JUSTIFICATION		
BY		
DISTRIBUTION/AVAILABILITY CODES		
Dist.	AVAIL. and/or	SPECIAL
A		

T A B L E O F C O N T E N T S

	<u>Page</u>
SUMMARY . . . . .	i
LIST OF FIGURES . . . . .	iii
INTRODUCTION . . . . .	1
DESCRIPTION AND DISCUSSION . . . . .	1
OPERATING CONDITIONS . . . . .	1
RESULTS AND COMMENTS . . . . .	2
CONCLUSION AND RECOMMENDATIONS . . . . .	3
CALCULATIONS . . . . .	3
REFERENCES . . . . .	11



L I S T O F F I G U R E S

<u>Figure No.</u>		<u>Page</u>
1	TDU-34/A Basic Data . . . . .	12
2	TDU-34/A Nose Afterbody Combinations . . . . .	13
3	Graphical Calculation of the MAC and Its Position . .	14

I N T R O D U C T I O N

This technical report documents the effects on the aerodynamics of a TDU-34/A target vehicle of six different nose cone-afterbody combinations.

D E S C R I P T I O N   A N D   D I S C U S S I O N

The basic data on the TDU-34/A target vehicle is shown in Figure 1. The six nose cone-afterbody combinations are shown in Figure 2 attached to the body of the TDU-34/A.

Configuration Figure 2-(I) is the basic "X" fin-body combination with a one caliber ogive nose cone and no afterbody.

Configuration Figure 2-(II) is the basic "X" fin-body with a 3 1/3 caliber rounded tapered nose cone and no afterbody.

Configuration Figure 2-(III) is the basic "X" fin-body with the one caliber nose cone and with a 2 caliber boat tail afterbody.

Configuration Figure 2-(IV) is the basic "X" fin-body with the one caliber nose cone and with a 1 1/2 caliber boat tail afterbody.

Configuration Figure 2-(V) is the basic "X" fin-body with the 3 1/2 caliber rounded tapered nose cone and with the 2 caliber afterbody.

Configuration Figure 2-(VI) is the basic "X" fin-body combination with the 3 1/2 caliber rounded tapered nose cone and with the 1 1/2 caliber boat tail afterbody.

The problem is to calculate the zero moment, center of pressure point for each configuration due to the aerodynamic loading and so determine the static stability margin defined as the distance from the center of pressure to the vehicle center of mass.

O P E R A T I N G   C O N D I T I O N S

The speed range is Mach 0.6 to 0.8. The angle of attack perturbations are around the zero and are small in magnitude, i.e.  $(-5^\circ < \alpha < +5^\circ)$ . It is presumed that the center of mass for the total vehicle can be maintained at the same position by adding balance mass and that the center of pressure from the aerodynamic loading on the fins remains essentially at the same location.

## RESULTS AND SOME COMMENTS

CONFIGURATION	CENTER OF PRESSURE (FOR BODY ALONE) LOCATION FROM NOSE	STATIC STABILITY MARGIN
2 - (I)	13.26"	17.4"
2 - (II)	18.02"	14.9"
2 - (III)	-10.30"	17.22"
2 - (IV)	- 9.70"	17.26"
2 - (V)	-13.10"	14.8"
2 - (VI)	-12.50"	14.9"

The following is a list, in decending order, of the static stability margin

STATIC STABILITY MARGIN	CONFIGURATION SEE FIG. 2
17.4"	2 - (I)
17.26"	2 - (IV)
17.22"	2 - (III)
14.9"	2 - (II)
14.9"	2 - (VI)
14.8"	2 - (V)

It can be seen that decreasing the nose cone length improves the static stability margin and that adding the boat tail after body reduces the static margin. From configurations (III), (IV), (V), and (VI) it can be seen that the boat tail after body moves the 'body-alone' center of pressure out in front of the nose of the vehicle. This later boat tail effect is the major influence of the body shape on the static stability margin.

Comparing configurations 2 - (I) and 2 - (II) shows that shortening the nose cone improves the static stability margin.

Comparing the static margin of 2 - (III) to 2 - (IV) and 2 - (V) to 2 - (VI) it is evident that the increased boat tail length improves the static stability margin slightly.

C O N C L U S I O N S   &   R E C O M M E N D A T I O N S

1. The highest static stability margin is provided by a short, one caliber ogive nose cone on the basic "X" - fin-body without the boat tail afterbody. See configuration (I), Figure 2.
2. The addition of the boat tail afterbody reduces the static margin.
3. The longer boat tail afterbody of 2 calibers produces a very slight improvement in the static stability over the shorter boat tail of 1 1/2 caliber.
4. If the boat tail on the short nosed vehicle can be faired out the static stability margin can be increased from 17.22 inches to 17.9 inches (i.e., an increase of 0.68 inches or 4%). However reference 4, page 3-20 indicates that a small drag penalty of  $\Delta D. = 0.07$  would result from fairing out the boat tail base to a constant diameter cylindrical base.

C A L C U L A T I O N S

To find the center of pressure (i.e., the line of action of the aerodynamic lifting forces) and the static stability margins of several nose cone afterbody combinations on a TDU-34/A target vehicle.

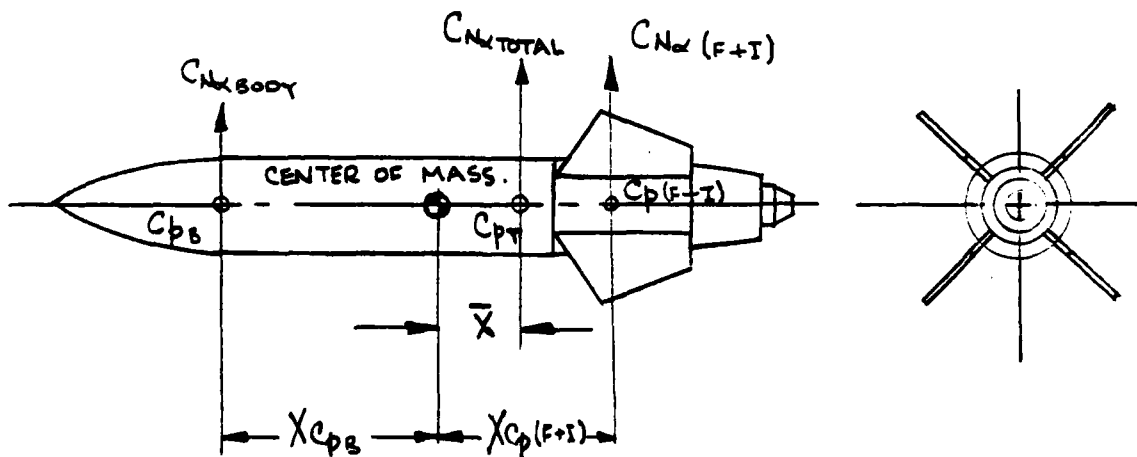

WHERE  $CN_{\alpha}$  = Normal lift coefficient vs. angle of attack derivative.  
 B → BODY → BODY ALONE  
 T → TOTAL → BODY + FINS + INTERFERENCE  
 F + I → FINS + INTERFERENCE  
 X → Position of line of action of the resultant aerodynamic force from the center of mass of total vehicle. (Defined as static stability margin).

$X_{cp}$  → Distance from center of pressure to center of mass.

TAKING MOMENTS ABOUT  $C_{pt}$ . (Clockwise positive)

$$C_{N\alpha B} (X_{cpB} + \bar{X}) = C_{N\alpha} (F+I) (X_{cp} (F+I) - \bar{X})$$

$$(C_{N\alpha B} + C_{N\alpha} (F+I)) \cdot \bar{X} = C_{N\alpha} (F+I) \cdot X_{cp} (F+I) - C_{N\alpha B} \cdot X_{cpB}$$

LET  $C_{N\alpha B} + C_{N\alpha} (F+I)$  BE DEFINED AS  $C_{N\alpha T}$

$$C_{N\alpha T} \cdot \bar{X} = C_{N\alpha} (F+I) \cdot X_{cp} (F+I) - C_{N\alpha B} \cdot X_{cpB}$$

$$\bar{X} = \frac{C_{N\alpha} (F+I) \cdot X_{cp} (F+I) - C_{N\alpha B} \cdot X_{cpB}}{C_{N\alpha T}}$$

$$C_{N\alpha} (F+I) = C_{N\alpha F} (1 + K_B(F) + K_F(B)) \text{ FROM Clark De Jonge (reference 2).}$$

WHERE  $C_{N\alpha F} = \text{FIN ALONE } C_{NX}$ .

$K_B(F) = \text{FINS ON BODY INTERFERENCE FACTOR.}$

$K_F(B) = \text{BODY ON FINS INTERFERENCE FACTOR.}$

( $K_B(F)$  AND  $K_F(B)$  ARE THE MORIKAWA INTERFERENCE FACTORS.)

$$K_F(B) = \lambda = d/b_0$$

WHERE  $d = \text{BODY DIAMETER (FT)} = 1 \text{ CALIBER.}$

$b = \text{FIN SEMI-SPAN (FT).}$

$b_0 = \text{TOTAL SPAN} = 2b + d \text{ (FT).}$

$$K_B(F) = \frac{C_{N\alpha B(F)}}{C_{N\alpha F}} = \frac{C_{LBi}}{C_{LW}} \text{ IN LOW AND STONE, reference 3.}$$

WHERE  $C_{LBi} = \text{COEFFICIENT OF LIFT OF BODY DUE TO WING (FIN) PRESENCE.}$

$C_{LW} = \text{COEFFICIENT OF LIFT OF WING (FIN).}$

WITH  $d = 12 \text{ INCHES}$

$b_0 = 36 \text{ INCHES}$

$$\lambda = \frac{12}{36} = \frac{1}{3}$$

$K_F(B) = 1/3$

AND FROM Figure 2 of LOW AND STONE (reference 1).

FOR  $b_0/d = 3 \rightarrow K_B(F) = 0.385$

HENCE  $C_{N\alpha}(F+I) = C_{N\alpha F} (1 + 0.333 + 0.385)$

$C_{N\alpha}(F+I) = 1.718 C_{N\alpha F}$

FIN ASPECT RATIO AR

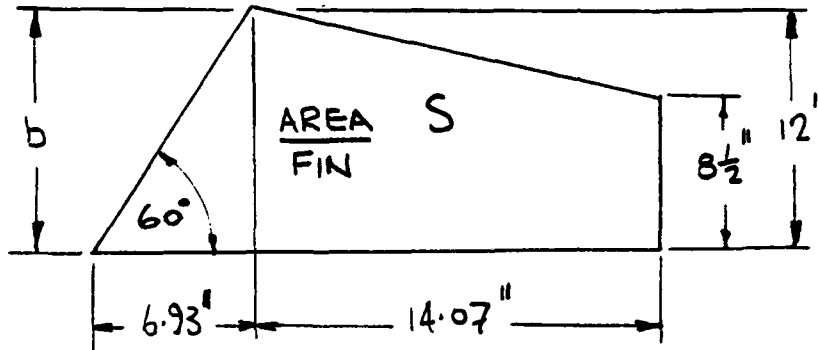

$$AR = \frac{2b^2}{S}$$

$$S = \frac{(12)(6.93)}{2(144)} + \frac{(8.5 + 12)(14.07)}{2(144)} = 1.29 \text{ FT}^2$$

$$AR = \frac{2(1)}{1.29} = 1.55.$$

THE EFFECTIVE AREA OF THE "X" FIN.

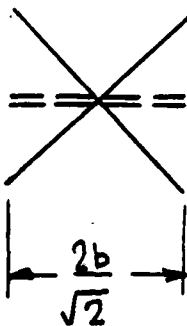
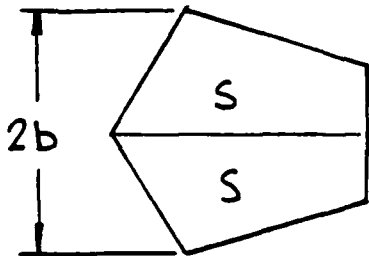

TOTAL EFFECTIVE FIN AREA

$$\Sigma A = \frac{4S}{\sqrt{2}} = 2\sqrt{2} S$$

$$\Sigma A = 3.6487 \text{ FT}^2$$

Coefficient of Normal Forces or Lift of Fins Alone. NOTE: The presumption has been made that for small angles of attack the normal force equals the lifting force. Page 13, Figure 7 in Clark De Jonge (reference 2) provides the following information for AR 1.55:

MACH#	$C_{N\alpha_F}$ (based on fin area).
0.4	2.1 / RAD
0.8	2.55 / RAD

SINCE  $C_{N\alpha(F+I)} = 1.718 C_{N\alpha_F}$

$$C_{N\alpha(F+I)} \Big|_{M=0.4} = (1.718)(2.1) = 3.608 / \text{RAD}$$

$$C_{N\alpha(F+I)} \Big|_{M=0.8} = (1.718)(2.55) = 4.3809 / \text{RAD}$$

The above are based on fin areas. To convert to the body cross sectional area as the reference area.

The area ratio is as follows:  $\frac{3.6487}{\frac{\pi (1)^2}{4}} \frac{\text{ft}^2}{\text{ft}^2}$

EFFECTIVE FIN AREA = 4.6456.  
BODY X. S. A.

Hence the fin normal force coefficients based on the body X. S. A. are:

$$C_{N\alpha(F+I)} \Big|_{\text{X.S.A. } M=0.4} = (3.6078)(4.6456) = 16.7605 / \text{RADIAN}$$

$$= \frac{16.7605}{\text{RAD.}} \frac{(2\pi)}{360} \frac{\text{RAD}}{\text{DEGREE}}$$

$$= 0.2925 / \text{DEGREE}$$

$$C_{N\alpha(F+I)} \Big|_{\text{X.S.A. } M=0.8} = (4.3809)(4.6456) = 20.3520 / \text{RADIAN}$$

$$= \frac{20.3520}{\text{RAD.}} \quad \frac{2\pi}{360} \quad \frac{\text{RAD}}{\text{DEGREE}}$$

$$= 0.3552/\text{DEGREE}$$

To Find The Position of the Center of Pressure for the Fins Alone.

Seckel (reference 5, page 8) gives the center of pressure at about 0.25 of the mean aerodynamic chord for subsonic flow. The mean aerodynamic chord (MAC) is the weighted average chord of all the wing section chords. Its length is:

$$\bar{C} = \frac{1}{S} \int_{-b/2}^{b/2} C^2 dy$$

and its position behind the root leading edge is:

$$X_{1emac} = \frac{1}{S} \int_{-b/2}^{b/2} (X_{1e})(C) dy.$$

Evaluating these two integrals graphically, see Appendix Figure 3.

gives  $\bar{C} = 17.227 \text{ ins} \rightarrow \frac{\bar{C}}{4} = 4.307 \text{ in.}$

$$X_{1emac} = 2.638 \text{ ins.}$$

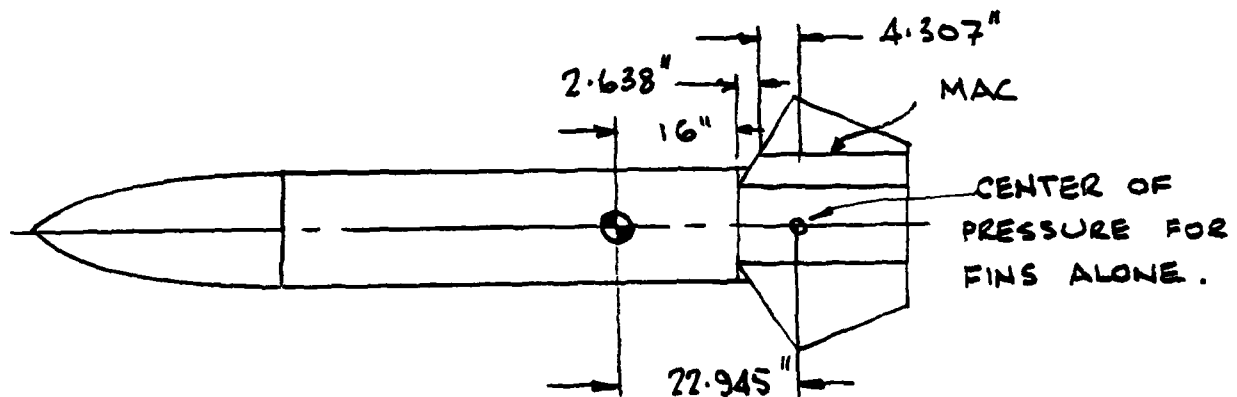

$$X_{cp(F+I)} = \frac{22.945}{12} = 1.912 \text{ FT BEHIND CENTER OF MASS.}$$



Coefficient of Lift or Normal Force for the Body Alone and The Position of the Center of Pressure. Clark De Jonge, Figure 1. (Reference 2) gives:

$$\left. \begin{aligned} C_{N\alpha B} &= 2.5/\text{RADIAN} \\ M &= 0.8 \end{aligned} \right\}$$

Horner and Borst, Page 19-17, (reference 3) gives the aerodynamic center position as:

$$\frac{\Delta x}{l} = \frac{d C_{me}}{d C_{Nb}} = \frac{0.012}{0.032} = 0.4$$

ahead of the reference point used in the particular wind tunnel tests, referred to and Figure 12 of page 19-8 gives the reference point as 0.57

Hence the aerodynamic center or the point about which the aerodynamic forces produce zero moment (true for a symmetrical body only) is as follows:

$$\frac{x}{l} = 0.57 - 0.4 = 0.17 \text{ BEHIND THE NOSE.}$$

This result is for the cylindrical body with a ogive nose cone and no afterbody. Adding a boat tail afterbody has a marked effect on the location of the body alone center of pressure. Moving it out ahead of the nose. Hoerner and Borst, Page 19-21 and page 19-17, Figure 26 reference 3 gives  $x/l = -0.1$  for boat tailed, ogive nosed cylinders (the minus sign implies that the center of pressure is in front of the nose) and  $x/l = + 0.17$  for the plain body alone. Along with this change in the center of pressure location there is a reduction in the lift coefficient derivative  $dC_{N\alpha B}/d\alpha$  from 2.5/RADIAN for the plain body alone to 1.7 /RADIAN for the boat tailed afterbody (about a 30% reduction).

For the six nose body afterbody combinations considered the location of the center of pressure for body alone is given below.

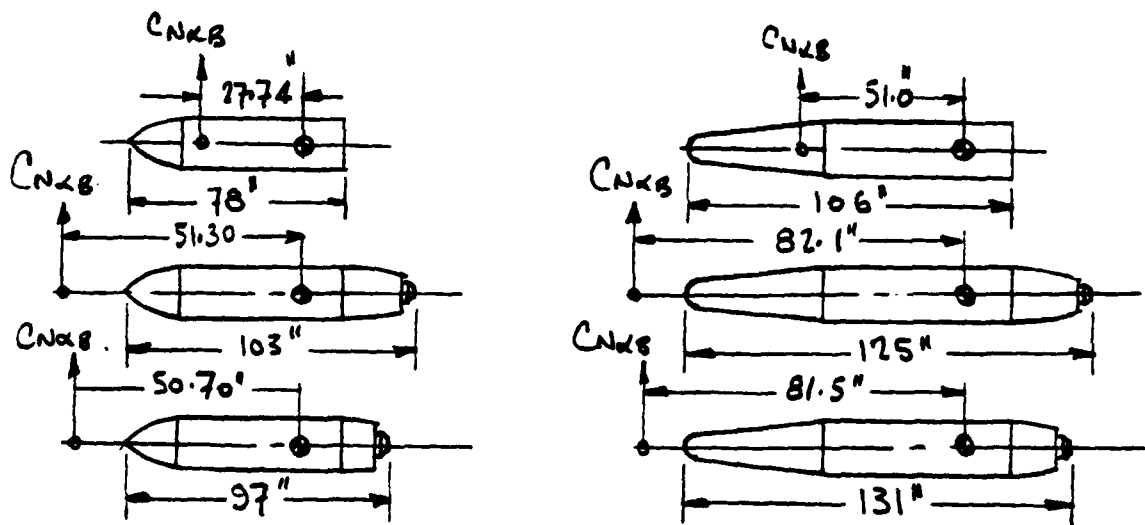

CALCULATIONS FOR THE STABILITY MARGINS FOR EACH CASE.

<p>(I)</p>	$\bar{X}_{(I)} = \frac{C_{N\alpha}(F+I) X_{cp}(F+I) - C_{N\alpha B} X_{cpB}}{C_{N\alpha TOTAL}}$ $= \frac{(20.352)(1.912) - (2.5)(2.311)}{(22.852)}$
<p>(II)</p>	$\bar{X}_{(I)} = 1.45 \text{ FT } + 17.4''$ $\bar{X}_{(II)} = \frac{(20.352)(1.912) - (2.5)(4.250)}{(22.852)}$
<p>(III)</p>	$\bar{X}_{(II)} = 1.24 \text{ FT } + 14.9''$ $\bar{X}_{(III)} = \frac{(20.352)(1.912) - (1.7)(4.275)}{(22.052)}$
<p>(IV)</p>	$\bar{X}_{(III)} = 1.435 \text{ FT } + 17.22''$ $\bar{X}_{(IV)} = \frac{(20.352)(1.912) - (1.7)(4.225)}{(22.052)}$
<p>(V)</p>	$\bar{X}_{(IV)} = 1.438 \text{ FT } + 17.26''$ $\bar{X}_{(V)} = \frac{(20.352)(1.912) - (1.7)(6.84)}{(22.052)}$
<p>(VI)</p>	$\bar{X}_{(V)} = 1.237 \text{ FT } + 14.8''$ $\bar{X}_{(VI)} = \frac{(20.352)(1.912) - (1.7)(6.79)}{(22.052)}$ $\bar{X}_{(VI)} = 1.241 \text{ FT } = 14.9''$

Considering the effect of fairing out the boat tail on configuration (III).

The center of pressure for the body alone will move from  $x/l = -0.10$  (in front of nose) to  $x/l = +0.17$  (behind the nose). But  $dC_{L\alpha}/d\alpha$  drops by about 30% by adding the boat tail (Hoerner & Borst, page 19-17, Figure 26, reference 3) from 2.5/RADIAN down to 1.7/RADIAN.

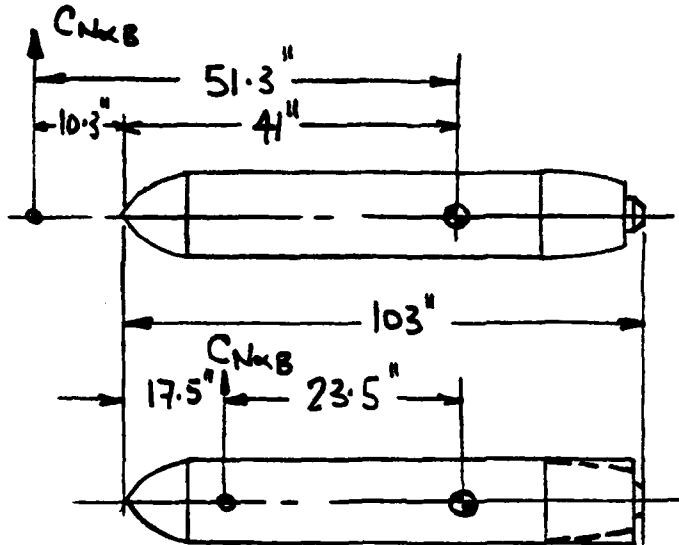

$$X_{cpB} = 51.3'' \rightarrow 4.275 \text{ FT}$$

$$X_{cpB} = 23.5'' \rightarrow 1.958 \text{ FT}$$

STATIC MARGIN FOR COMPLETE VEHICLE

$$\bar{X} = \frac{C_{N\alpha}(F+I) X_{cp}(F+I) - C_{N\alpha B} X_{cpB}}{C_{N\alpha TOTAL}}$$

$$\bar{X}_{(III) \text{ BOAT-TAIL}} = \frac{(20.352)(1.912) - (1.7)(4.275)}{(22.052)} = 1.435 \text{ FT} \rightarrow 17.22''$$

$$\bar{X}_{(III) \text{ FAIRED}} = \frac{(20.352)(1.912) - (2.5)(1.96)}{(22.852)} = 1.488 \text{ FT} \rightarrow 17.9''$$

R E F E R E N C E S

1. REPORT: "The Subsonic Aerodynamic Characteristics of Wings in Combination with Slender Bodies of Revolution." By L. Low & H. N. Stone. July. 1951. Report No. CAL/CM-679. Cornell Aeronautical Laboratory, Inc.
2. REPORT: "The Effect of Low Aspect Ratio Rectangular and Delta Cruciform Fins on the Stability of Bodies of Revolution with Tangent Ogives at Small Angles of Attack Through A Mach Number Range of 0 to 3.5." By Clark De Jonge. July 1962, Report No. RF-TR-62-1, Revised AOMC (U.S. Army Ordinance Command).
3. BOOK: "Fluid-Dynamic Lift" By Hoerner & Borst. 1975. Published by Mrs. L. A. Hoerner.
4. BOOK: "Fluid-Dynamic Drag" By Hoerner 1965. Published by the Author.
5. BOOK: "Stability & Control of Airplanes & Helicopters." By Edward Seckel, 1964, Published by Academic Press.

DATA SUMMARY.

AERO (ORIGIN AT O, TOW POINT)

$C_D = 0.5$

$C_{L\alpha} = 0.3908/\text{DEGREE} = C_{L\beta}$

$C_{L\alpha_{FI}} = 0.355/\text{DEGREE} = C_{L\beta_{FI}}$

$X_{CP} = -1.361 \text{ FT (SUBSONIC)}$

$X_{CP(FIN)} = -2.079 \text{ FT}$

$X_{CG} = -0.167 \text{ FT}$

$Z_{\dot{\alpha}} = -0.4385 \text{ FT}$

$XSA = 0.785 \text{ FT}^2$

MASS PROPERTIES

CONFIGURATION	BASIC	VTASP
WEIGHT (LBS)	90	200
$I_{xx}$ (LB-IN-SEC <sup>2</sup> )	6.4	9.2
$I_{yy} = I_{zz}$ (LB-IN-SEC <sup>2</sup> )	274.3	411.8

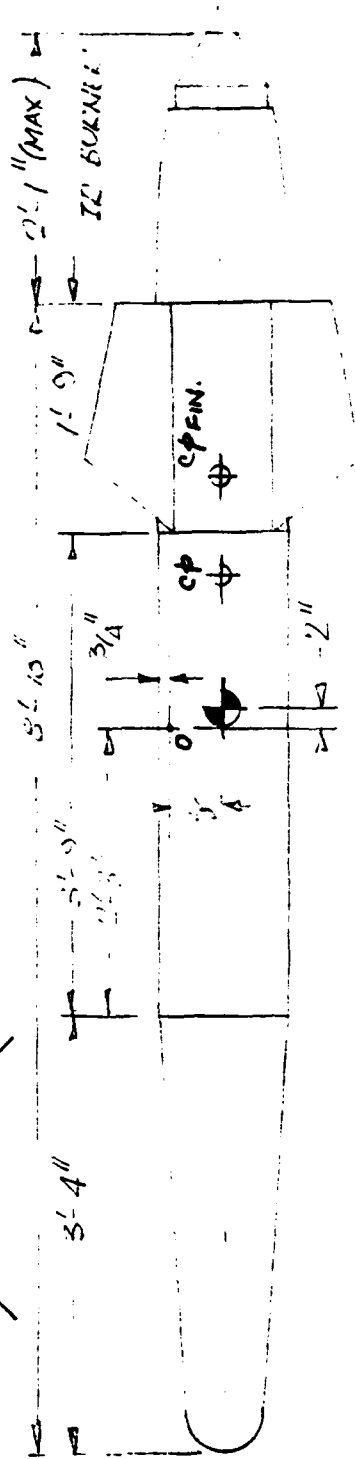
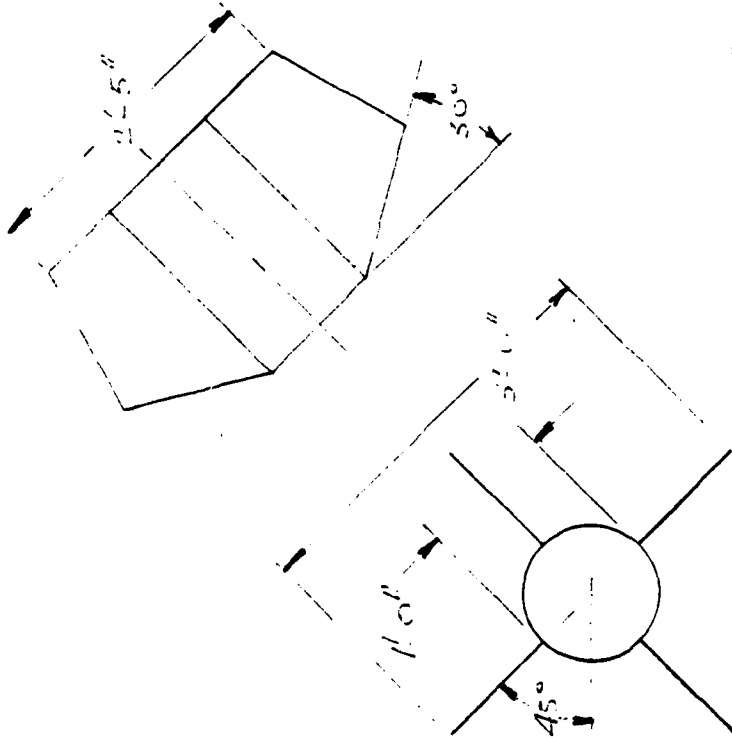

FIGURE 1. TDU-34/A BASIC DATA

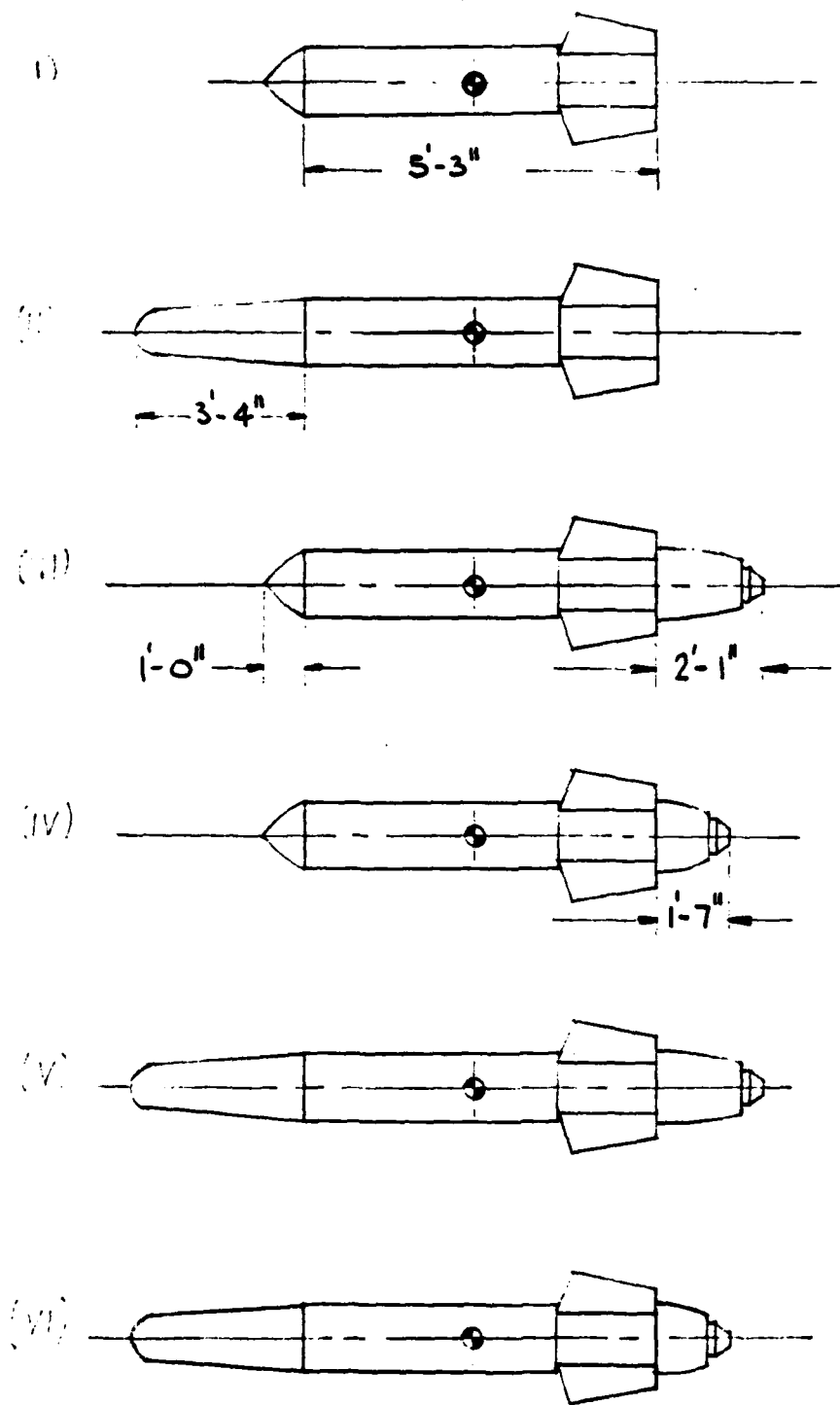
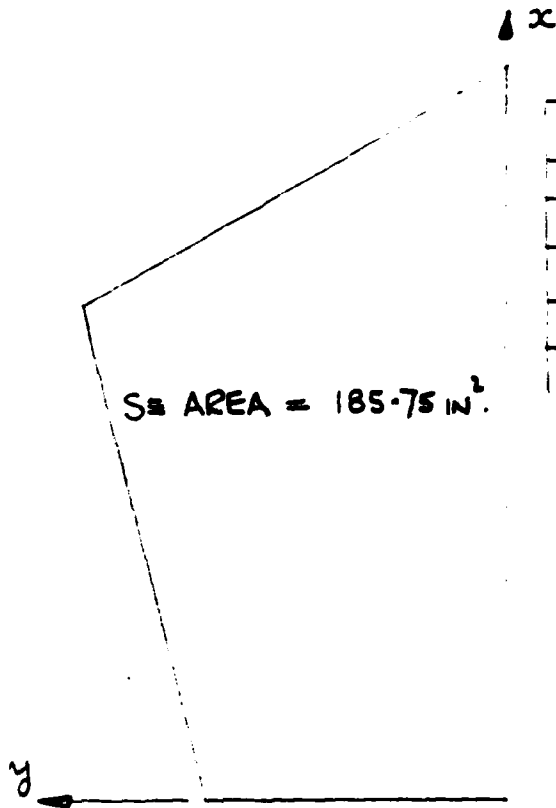

FIGURE 2. TDU-34/A NOSE-AFTERBODY COMBINATIONS



y	c	c <sup>2</sup>	x <sub>LC</sub>	Cx <sub>LC</sub>
12	0	0	6.93	0
10	8.19	67.0	5.77	47.3
8	16.38	269.3	4.62	76.67
4	18.69	349.3	2.31	43.17
0	21.00	441.0	0	0

$$\bar{c} = \frac{1}{S} \int_{-b/2}^{b/2} c^2 dy$$

$$x_{Lmac} = \frac{1}{S} \int_{-b/2}^{b/2} x_{LC} c dy$$

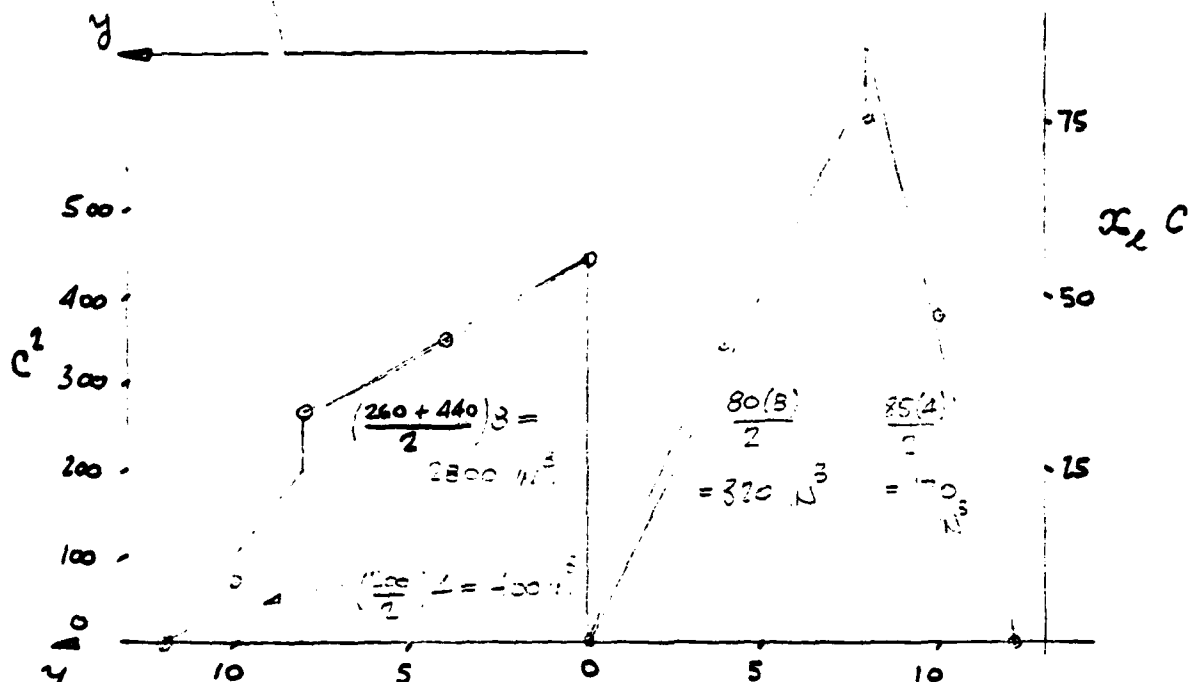

$$\bar{c} = \frac{\sum C_i^2 \Delta y_i}{S} = \frac{3200}{185.75}$$

$$\bar{c} = 17.277 \text{ IN.}$$

$$x_{Lmac} = \frac{\sum x_{LC} C \Delta y_i}{S} = \frac{490}{185.75}$$

$$x_{Lmac} = 2.638 \text{ IN.}$$

FIGURE 3. GRAPHICAL CALCULATION OF THE MAC & ITS POSITION