

**NAVAL SUBMARINE MEDICAL
RESEARCH LABORATORY
SUBMARINE BASE, GROTON, CONN.**

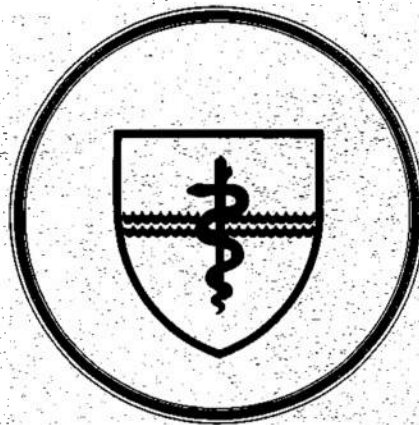

REPORT NUMBER 927

A SIMPLE DEVICE FOR ADDING OPTICAL CORRECTIONS
TO PERISCOPES

by

S. M. Luria

and

Jo Ann S. Kinney

Naval Medical Research and Development Command
Research Work Unit MF58.524.006-2195

Released by:

R. A. Margulies, CDR, MC, USN
Commanding Officer
Naval Submarine Medical Research Laboratory

3 March 1980

Approved for public release; distribution unlimited

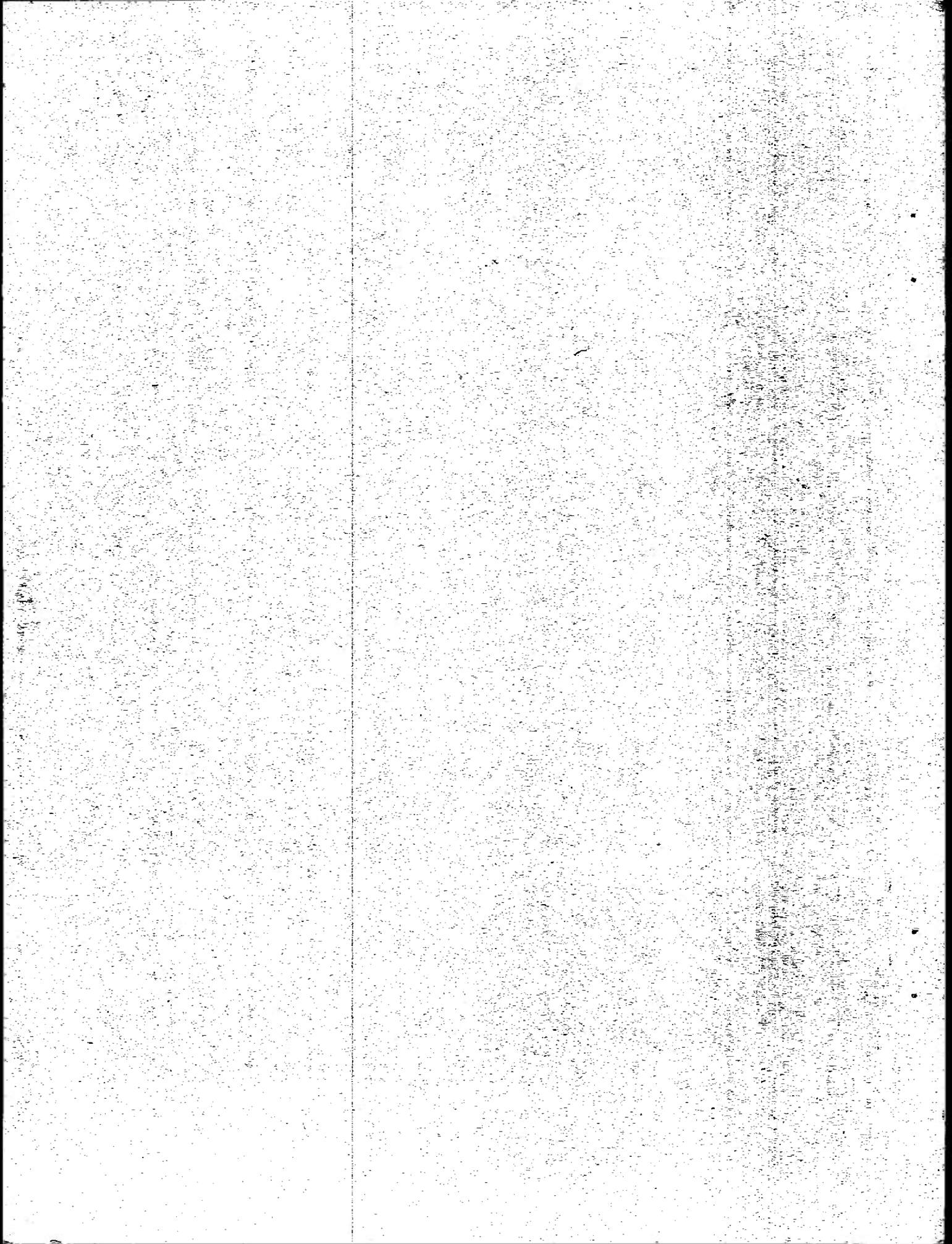

A SIMPLE DEVICE FOR ADDING OPTICAL CORRECTIONS TO PERISCOPES

by

S. M. Luria, Ph.D.

and

Jo Ann S. Kinney, Ph.D.

NAVAL SUBMARINE MEDICAL RESEARCH LABORATORY
REPORT NUMBER 927

NAVAL MEDICAL RESEARCH AND DEVELOPMENT COMMAND
Research Work Unit MF58.524.006-2195

Approved and Released by

R. A. Margulies, CDR MC USN
Commanding Officer
NavSubMedRschLab

Approved for public release; distribution unlimited

SUMMARY PAGE

PROBLEM:

To describe a simple method of introducing corrections for cylindrical errors to periscope optics which would not interfere with vision through the periscope and would not compromise the integrity of the periscope.

FINDINGS

A simple alteration in the removable eye-piece of the periscope makes it possible to insert corrective lenses whose orientation is completely defined and which do not interfere with the observer's vision through the instrument.

APPLICATION

Such a modification to the periscope, made either by the manufacturer or the ship's crew, will materially enhance the visual performance of astigmatic operators now on duty and will make it possible to relax astigmatism standards and enlarge the pool of men available for periscope duty.

ADMINISTRATIVE INFORMATION

This investigation was conducted under Naval Medical Research and Development Command Work Unit MF58.524.006-2195 -- "Feasibility of increased utilization of astigmatic periscope operators." It was submitted for review on 25 February 1980, approved for publication on 3 Mar 1980, and designated as NavSubMedRSchLab Report No. 927.

PUBLISHED BY THE NAVAL SUBMARINE MEDICAL RESEARCH LABORATORY

ABSTRACT

A simple method of introducing optical corrections for periscope operators is described which neither compromises the integrity of the periscope nor impairs the ability of the operator to look through the periscope. This method makes it feasible to correct astigmatic operators as well as individuals with high spherical error.

INTRODUCTION

The human eye exhibits two kinds of refractive error, spherical, in which the error is of the same magnitude in all meridians, and cylindrical, in which it is not. The latter results in the visual anomaly called astigmatism. Although both of these types of refractive error can be overcome with eyeglasses, it is, unfortunately, difficult to look through a periscope while wearing glasses.

Moreover, it is easy in complex optical systems to correct for spherical errors but not for cylindrical ones. Thus binoculars, microscopes, and periscopes generally provide a sizeable amount of spherical correction for the user but no correction for astigmatism. The reason is that the axis of the lens must be precisely oriented. For different individuals, then, both the magnitude of the lens and its orientation will be different. Not only is it not feasible to provide such a wide range of lenses in an optical instrument, but even if such a provision were made, it would be difficult for the user to select for himself the proper magnitude and orientation of the correction. It has been shown that individuals typically do not select their optimal spherical correction;¹ the chances of their selecting the proper cylindrical correction are much less.

Since uncorrected astigmatism may result in a significant loss of visual acuity,² visual standards for periscope operators have for many years been more stringent than standards for other Navy men.³ Yet, according to optometric authorities, astigmatism is the most widely prevalent anomaly presented for correction:⁴ it is found in more than 80 percent of all patients examined.⁵ Twenty years ago, Hofstetter reported that 14 percent of individuals in the 20 to 29 age range had astigmatism.⁶ In a recent survey of 1000 submariners--men constituting a highly selected sample who had already been screened to eliminate large amounts of astigmatism--we found that 56

percent had a measurable amount of the defect. It appears, therefore, that an appreciable percentage of otherwise qualified men is liable to be disqualified from submarine service on this account, at a time when one of the problems facing the Navy is the recruitment of a sufficient number of men.

If, however, a feasible method of introducing corrections for cylindrical errors into the periscope optics could be devised, it would be possible to relax the stringent standards for astigmatism and to make available a larger number of men suitable for periscope duty. Such a method was developed during a research project which measured the vision of astigmats through periscopes.⁷ It produced completely satisfactory results. This report describes the method.

In attempting to add corrective lenses for a specific operator to the optical system of the periscope, there are two approaches that cannot be taken. First, a cylindrical lens cannot be introduced at will into the body of the periscope, since it would disturb its complex optics or otherwise impair its integrity. Second, a lens cannot be positioned too far outside the eye-piece, since that makes it difficult to see through the periscope.

Fortunately, the design of the periscope provides another alternative which avoids both these problems. The eye-piece of the periscope is so designed that it can be easily removed and positioned in either of two configurations in order to enable the operator to look with either his right or left eye. Figure 1 shows a diagram of the eye-piece assembly from the front and the side. The side view shows that there is a rather thick plate to which the eyecup is attached. This part of the assembly is large enough to contain a spectacle lens.

All that is needed is a method for insuring that the corrective lens is always inserted in exactly the same orientation.

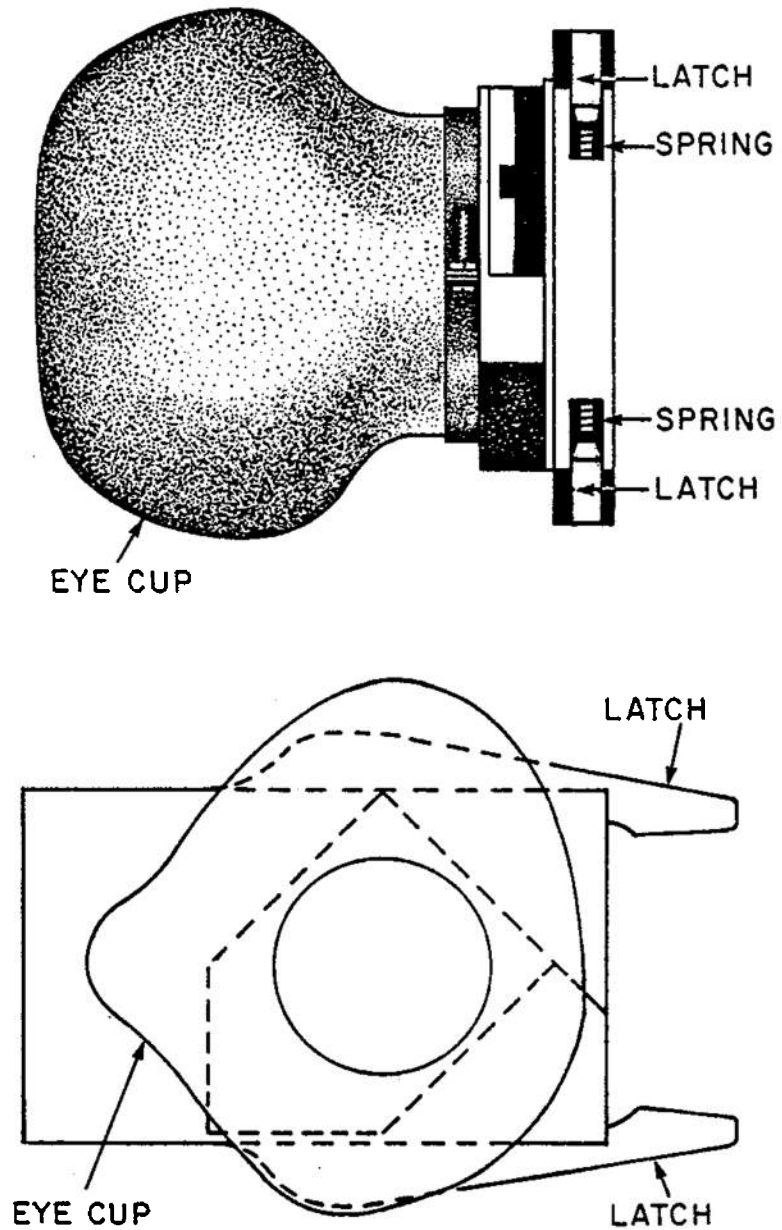

Fig. 1. Diagram of the periscope eye-piece assembly from the side (top) and the front (bottom). The black "T" shaped area in the top diagram is the slit for the lens holder. The dotted lines in the lower diagram show the position of the lens holder.

Figure 2 is a lens holder with a cylindrical lens permanently attached with the axis at 45° . The lens holder can be inserted in only one way because of its shape and the guide-ridge along the top of the holder. Once inserted, it does not interfere with the positioning of the eye in the eyecup. Such a holder with the appropriate correction for each periscope operator insures optimal vision for each man. Figure 3 is a photograph of the eye-piece and the lens holder.

In operation, each man could have his own correction in his own lens holder which could be attached near or to the periscope; when needed each operator could quickly insert his own lens.

There is one additional advantage. Spherical corrections could likewise be inserted in the same type of lens holder. This would permit the use of individuals with spherical errors that are too large to be compensated for with the current periscope corrections.

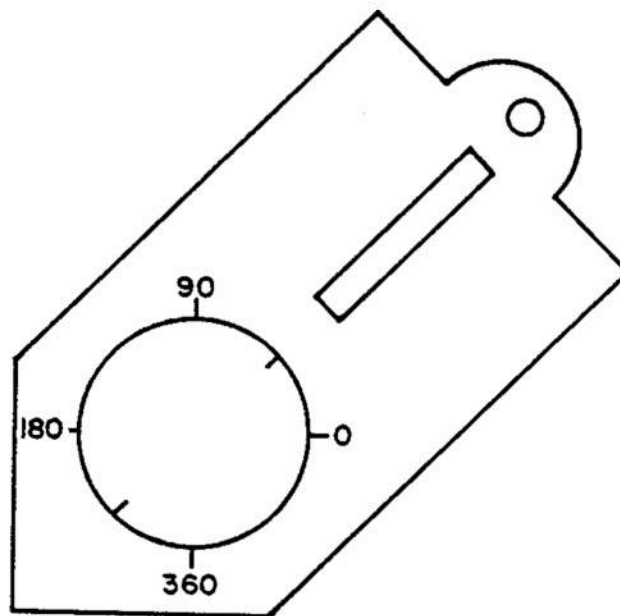

Fig. 2. Diagram of the lens holder showing the position of a cylinder lens with the axis at 45° .



Fig. 3. Photograph of the eye-piece and lens holder with a cylinder lens positioned with axis at 90° .

REFERENCES

1. Verplanck, W. S. and C. E. Osgood. Field tests of optical instruments. NavOrd Report 77-46, Washington: Navy Department, Bureau of Ordnance, March 1947, p. 197.
2. Kinney, J. A. S. and C. H. Pratt. The effect of refractive error on acuity through binoculars. NSMRL Rep. No. 245, NAVSUBMEDRSCHLAB, Groton, CT, Apr 1954.
3. Kinney, J. A. S. A history and rationale of visual acuity standards for submariners. NSMRL Memo Rep. 70-6, NAVSUBMEDRSCHLAB, Groton, CT, Aug 1970.
4. Borish, I. M. Clinical Refraction, 3rd ed., Chicago: Professional Press Inc., 1970, p.127.
5. Bannon, R. E. and R. Walsh. Repeatability of keratometric readings. Am. J. Ophthalmol. 29, 76-85, 1946.
6. Hofstetter, H. W. A keratoscopic survey of 13,395 eyes. Arch. Am. Assoc. Optom. 36, 3-11, 1959.
7. Luria, S. M., J. A. S. Kinney, C. L. Schlichting, and A. P. Ryan. The limiting effects of astigmatism on visual performance through periscopes. NSMRL Rep. No. 905, NAVSUBMEDRSCHLAB, Groton, CT, Sep 1979.

REPORT DOCUMENTATION PAGE		READ INSTRUCTIONS BEFORE COMPLETING FORM
1. REPORT NUMBER NSMRL Report Number 927	2. GOVT ACCESSION NO.	3. RECIPIENT'S CATALOG NUMBER
4. TITLE (and Subtitle) A SIMPLE DEVICE FOR ADDING OPTICAL CORRECTIONS TO PERISCOPEs		5. TYPE OF REPORT & PERIOD COVERED Interim report
		6. PERFORMING ORG. REPORT NUMBER NSMRL Report No. 927
7. AUTHOR(s) S. M. LURIA and J. A. S. KINNEY		8. CONTRACT OR GRANT NUMBER(s)
9. PERFORMING ORGANIZATION NAME AND ADDRESS Naval Submarine Medical Research Laboratory Box 900 Naval Submarine Base Groton, Connecticut 06340		10. PROGRAM ELEMENT, PROJECT, TASK AREA & WORK UNIT NUMBERS MF58.524.006-2195
11. CONTROLLING OFFICE NAME AND ADDRESS Naval Submarine Medical Research Laboratory Box 900 Naval Submarine Base Groton, Connecticut 06340		12. REPORT DATE 3 March 1980
		13. NUMBER OF PAGES 6
14. MONITORING AGENCY NAME & ADDRESS (if different from Controlling Office) Naval Medical Research and Development Command National Naval Medical Center Bethesda, Maryland 20014		15. SECURITY CLASS. (of this report) Unclassified
		15a. DECLASSIFICATION/DOWNGRADING SCHEDULE
16. DISTRIBUTION STATEMENT (of this Report) Approved for public release; distribution unlimited		
17. DISTRIBUTION STATEMENT (of the abstract entered in Block 20, if different from Report)		
18. SUPPLEMENTARY NOTES		
19. KEY WORDS (Continue on reverse side if necessary and identify by block number) periscopes; refractive corrections; visual standards; optical device		
20. ABSTRACT (Continue on reverse side if necessary and identify by block number) A simple method of introducing optical corrections for periscope operators is described which neither compromises the integrity of the periscope nor impairs the ability of the operator to look through the periscope. This method makes it feasible to correct astigmatic operators as well as individuals with high spherical error.		

UNCLASSIFIED

SECURITY CLASSIFICATION OF THIS PAGE(When Data Entered)

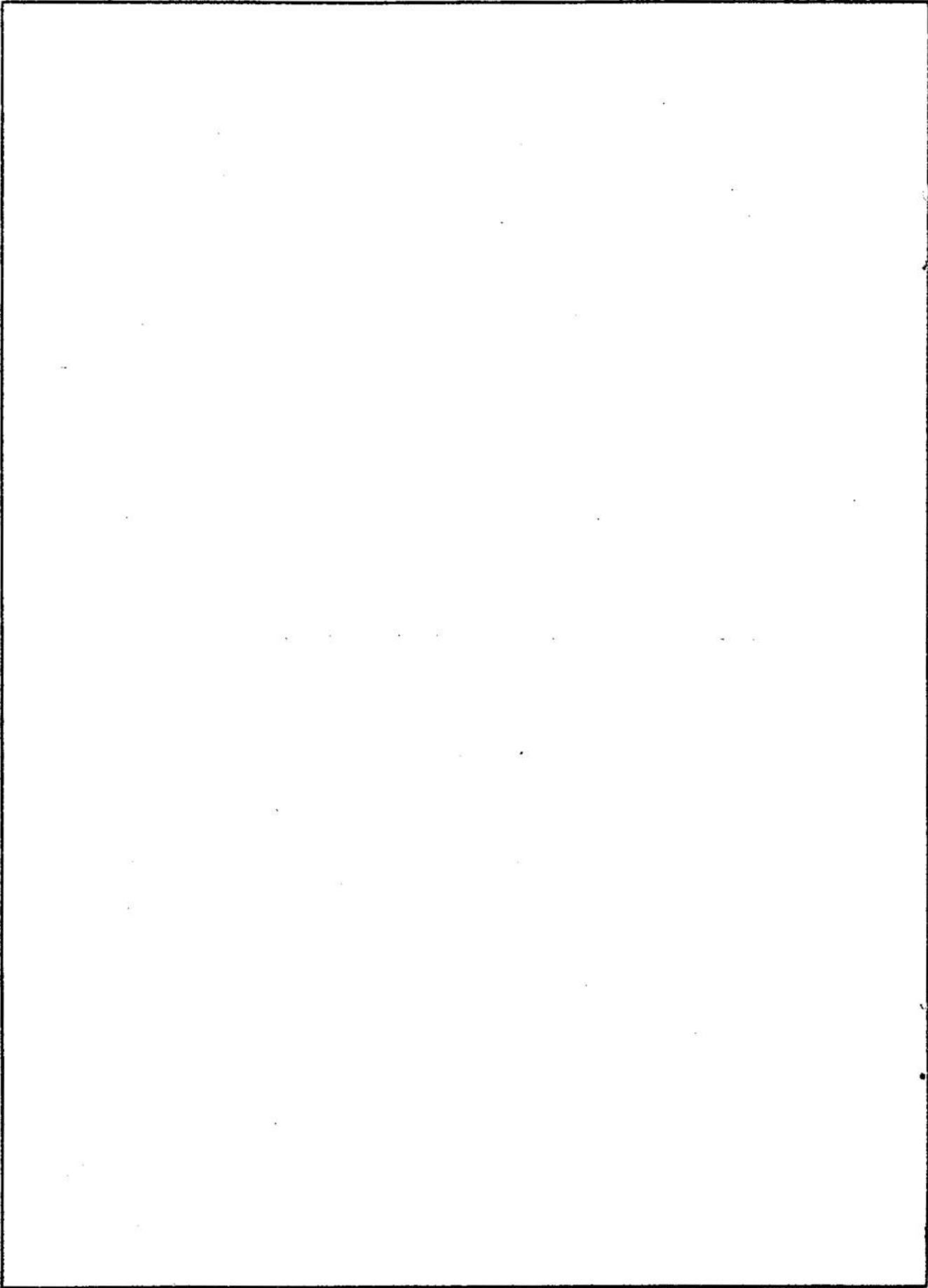

UNCLASSIFIED

SECURITY CLASSIFICATION OF THIS PAGE(When Data Entered)