

AD-A 083 866

AD-A083886

TECHNICAL REPORT ARBRL-TR-02221

DYNAMICS OF A LIQUID-FILLED GYROSCOPE:  
UPDATE OF THEORY AND EXPERIMENT

Richard D. Whiting  
Nathan Gerber

TECHNICAL  
LIBRARY

March 1980

DTC QUALITY INSPECTED 2



US ARMY ARMAMENT RESEARCH AND DEVELOPMENT COMMAND  
BALLISTIC RESEARCH LABORATORY  
ABERDEEN PROVING GROUND, MARYLAND

Approved for public release; distribution unlimited.

Destroy this report when it is no longer needed.  
Do not return it to the originator.

Secondary distribution of this report by originating  
or sponsoring activity is prohibited.

Additional copies of this report may be obtained  
from the National Technical Information Service,  
U.S. Department of Commerce, Springfield, Virginia  
22151.

The findings in this report are not to be construed as  
an official Department of the Army position, unless  
so designated by other authorized documents.

*The use of trade names or manufacturers' names in this report  
does not constitute endorsement of any commercial product.*

| REPORT DOCUMENTATION PAGE  |                             | READ INSTRUCTIONS<br>BEFORE COMPLETING FORM  |                  |                    |                 |                             |                     |                          |                       |  |                     |  |
|--|-----------------------------|--|------------------|--------------------|-----------------|-----------------------------|---------------------|--------------------------|-----------------------|--|---------------------|--|
| 1. REPORT NUMBER<br>TECHNICAL REPORT ARBRL-TR-02221  | 2. GOVT ACCESSION NO.       | 3. RECIPIENT'S CATALOG NUMBER  |                  |                    |                 |                             |                     |                          |                       |  |                     |  |
| 4. TITLE (and Subtitle)<br>DYNAMICS OF A LIQUID-FILLED GYROSCOPE: UPDATE<br>OF THEORY AND EXPERIMENT   |                             | 5. TYPE OF REPORT & PERIOD COVERED<br>Final  |                  |                    |                 |                             |                     |                          |                       |  |                     |  |
|  |                             | 6. PERFORMING ORG. REPORT NUMBER   |                  |                    |                 |                             |                     |                          |                       |  |                     |  |
| 7. AUTHOR(s)<br>Richard D. Whiting<br>Nathan Gerber  |                             | 8. CONTRACT OR GRANT NUMBER(s)   |                  |                    |                 |                             |                     |                          |                       |  |                     |  |
| 9. PERFORMING ORGANIZATION NAME AND ADDRESS<br>U.S. Army Ballistic Research Laboratory<br>(ATTN: DRDAR-BLL)<br>Aberdeen Proving Ground, Maryland 21005   |                             | 10. PROGRAM ELEMENT, PROJECT, TASK<br>AREA & WORK UNIT NUMBERS<br><br>RDT&E 1L161102AH43 |                  |                    |                 |                             |                     |                          |                       |  |                     |  |
| 11. CONTROLLING OFFICE NAME AND ADDRESS<br>U.S. Army Armament Research & Development Command<br>U.S. Army Ballistic Research Laboratory<br>(ATTN: DRDAR-BL) Aberdeen Proving Ground, MD 21005  |                             | 12. REPORT DATE<br>MARCH 1980  |                  |                    |                 |                             |                     |                          |                       |  |                     |  |
|  |                             | 13. NUMBER OF PAGES<br>51  |                  |                    |                 |                             |                     |                          |                       |  |                     |  |
| 14. MONITORING AGENCY NAME & ADDRESS (if different from Controlling Office)  |                             | 15. SECURITY CLASS. (of this report)<br><br>Unclassified                                 |                  |                    |                 |                             |                     |                          |                       |  |                     |  |
|  |                             | 15a. DECLASSIFICATION/DOWNGRADING<br>SCHEDULE  |                  |                    |                 |                             |                     |                          |                       |  |                     |  |
| 16. DISTRIBUTION STATEMENT (of this Report)<br><br>Approved for public release; distribution unlimited.  |                             |  |                  |                    |                 |                             |                     |                          |                       |  |                     |  |
| 17. DISTRIBUTION STATEMENT (of the abstract entered in Block 20, if different from Report)   |                             |  |                  |                    |                 |                             |                     |                          |                       |  |                     |  |
| 18. SUPPLEMENTARY NOTES  |                             |  |                  |                    |                 |                             |                     |                          |                       |  |                     |  |
| 19. KEY WORDS (Continue on reverse side if necessary and identify by block number)   |                             |  |                  |                    |                 |                             |                     |                          |                       |  |                     |  |
| <table border="0"> <tr> <td>Eigenfrequencies</td> <td>Coning Frequencies</td> </tr> <tr> <td>Yaw Growth Rate</td> <td>Stewartson-Wedemeyer Theory</td> </tr> <tr> <td>Liquid-Filled Shell</td> <td>Liquid-Filled Gyroscopes</td> </tr> <tr> <td>Gyroscope Experiments</td> <td></td> </tr> <tr> <td>Solid-Body Rotation</td> <td></td> </tr> </table>  |                             |  | Eigenfrequencies | Coning Frequencies | Yaw Growth Rate | Stewartson-Wedemeyer Theory | Liquid-Filled Shell | Liquid-Filled Gyroscopes | Gyroscope Experiments |  | Solid-Body Rotation |  |
| Eigenfrequencies   | Coning Frequencies          |  |                  |                    |                 |                             |                     |                          |                       |  |                     |  |
| Yaw Growth Rate  | Stewartson-Wedemeyer Theory |  |                  |                    |                 |                             |                     |                          |                       |  |                     |  |
| Liquid-Filled Shell  | Liquid-Filled Gyroscopes    |  |                  |                    |                 |                             |                     |                          |                       |  |                     |  |
| Gyroscope Experiments  |                             |  |                  |                    |                 |                             |                     |                          |                       |  |                     |  |
| Solid-Body Rotation  |                             |  |                  |                    |                 |                             |                     |                          |                       |  |                     |  |
| 20. ABSTRACT (Continue on reverse side if necessary and identify by block number) (1cb)  |                             |  |                  |                    |                 |                             |                     |                          |                       |  |                     |  |
| <p>New comparisons are made between the theory of Stewartson, as modified by Wedemeyer, and existing experimental measurements of the motion of liquid-filled gyroscopes. Errors in previous comparisons are pointed out and corrected, as are some errors in several published presentations of the theory. Because some key parameters were not recorded during the experiments, complete comparisons of theoretical predictions with observed behavior cannot be made. The limited comparisons which can be made show that predicted and measured (Continued)</p> |                             |  |                  |                    |                 |                             |                     |                          |                       |  |                     |  |

UNCLASSIFIED

SECURITY CLASSIFICATION OF THIS PAGE(When Data Entered)

20. ABSTRACT (Continued):

frequencies of greatest instability of the motion agree to within the experimental error; the growth rates at those frequencies agree to within 10% for Reynolds number  $> 10^4$ , and to within 25% for lower Reynolds number.

UNCLASSIFIED

SECURITY CLASSIFICATION OF THIS PAGE(When Data Entered)

## TABLE OF CONTENTS

|  | <u>Page</u> |
|--|-------------|
| LIST OF FIGURES . . . . .                                | 5           |
| I. INTRODUCTION . . . . .                                | 7           |
| A. Background . . . . .                                  | 7           |
| B. Purpose of This Report . . . . .                      | 8           |
| II. THEORY . . . . .                                     | 10          |
| A. Equations of Motion of the Gyroscope . . . . .        | 10          |
| B. Exponential Solutions . . . . .                       | 11          |
| C. Evaluation of the Liquid Moment . . . . .             | 12          |
| C.1. Inviscid Theory: Approximation Near Resonance . . . | 13          |
| C.2. Viscous Correction for Large Reynolds Number . . .  | 13          |
| D. Solution for $\tau$ . . . . .                         | 15          |
| E. Review of Assumptions . . . . .                       | 15          |
| III. THE EXPERIMENT . . . . .                            | 16          |
| A. Description . . . . .                                 | 16          |
| B. The Results of Karpov . . . . .                       | 18          |
| C. Results of D'Amico, Kitchens, and Frasier . . . . .   | 19          |
| IV. CONCLUDING REMARKS . . . . .                         | 20          |
| REFERENCES . . . . .                                     | 31          |
| LIST OF SYMBOLS . . . . .                                | 33          |
| APPENDIX A . . . . .                                     | 35          |
| APPENDIX B . . . . .                                     | 37          |
| DISTRIBUTION LIST . . . . .                              | 45          |

LIST OF FIGURES

| <u>Figure</u> | <u>Page</u>  |
|---------------|--|
| 1.            | Schematic Diagram of Gyroscope . . . . . 21  |
| 2.            | Schematic Diagram of Coordinates . . . . . 21  |
| 3.            | Coning Frequencies and Yaw Growth Rates for Karpov<br>Liquid # 1 Experiments ( $a = 3.150$ cm, $c = 9.691$ cm,<br>$\rho = 0.818$ g/cm <sup>3</sup> , $L = 1.968 \times 10^5$ g cm <sup>2</sup> , $\nu = 0.01$ cm <sup>2</sup> /s,<br>$\tau_n = 0.0534$ ; $n = 1, j = 1$ ) . . . . . 22 |
| 4.            | Coning Frequencies and Yaw Growth Rates for Karpov<br>Liquid # 2 Experiments ( $a = 3.150$ cm, $c = 9.691$ cm,<br>$\rho = 0.818$ g/cm <sup>3</sup> , $L = 1.968 \times 10^5$ g cm <sup>2</sup> , $\nu = 1.0$ cm <sup>2</sup> /s,<br>$\tau_n = 0.0534$ ; $n = 1, j = 1$ ) . . . . . 23  |
| 5.            | Sensitivity of Yaw Growth Rate to Change in Cylinder<br>Aspect Ratio in Karpov's Experiments ( $a = 3.150$ cm,<br>$c = 9.691$ cm, $L = 1.968 \times 10^5$ g cm <sup>2</sup> , $\tau_n = 0.0534$ ;<br>$n = 1, j = 1$ ) . . . . . 24   |
| 6.            | - $\tau_I$ vs $\tau_R$ for D'Amico's 79% Filled Cylinder<br>Experiments, $Re = 5.2 \times 10^5$ and $Re = 4.0 \times 10^4$<br>( $a = 3.153$ cm, $c = 9.500$ cm, $(b/a)^2 = 0.210$ ;<br>$n = 1, j = 1$ ) . . . . . 25   |
| 7.            | - $\tau_I$ vs $\tau_R$ for D'Amico's 79% Filled Cylinder<br>Experiments, $Re = 1.1 \times 10^4$ and $Re = 5.2 \times 10^3$<br>( $a = 3.153$ cm, $c = 9.500$ cm, $(b/a)^2 = 0.210$ ;<br>$n = 1, j = 1$ ) . . . . . 26   |
| 8.            | - $\tau_I$ vs $\tau_R$ for 100% Filled Cylinders, Experiments of<br>D'Amico and Kitchens ( $a = 3.153$ cm, $c = 9.928$ cm;<br>$n = 1, j = 1$ ) . . . . . 27  |
| 9.            | - $\tau_I$ vs $\tau_R$ for Frasier (Rod) Experiments, $Re = 5.2 \times 10^5$<br>and $Re = 1.70 \times 10^5$ ( $a = 3.153$ cm, $c = 9.030$ cm,<br>$(d/a)^2 = 0.023$ ; $n = 1, j = 1$ ) . . . . . 28   |
| 10.           | - $\tau_I$ vs $\tau_R$ for Frasier (Rod) Experiments, $Re = 4.0 \times 10^4$<br>( $a = 3.153$ cm, $c = 9.030$ cm, $(d/a)^2 = 0.023$ ;<br>$n = 1, j = 1$ ) . . . . . 29   |

LIST OF FIGURES (Continued)

| <u>Figure</u> |  | <u>Page</u> |
|---------------|--|-------------|
| 11.           | Sensitivity of $-\tau_I$ vs $\tau_R$ Curves to Change in Cylinder Aspect Ratio: (a) D'Amico 100% Filled Cylinder, $a = 3.153$ cm, $c = 9.928$ cm, $j = 1$ , $n = 1$ ;<br>(b) Frasier Cylinder With Inner Burster, $a = 3.153$ cm, $c = 9.030$ cm, $(d/a)^2 = 0.02$ , $n = 1$ , $j = 1 . . . .$ | 30          |

## I. INTRODUCTION

### A. Background

In 1959 K. Stewartson<sup>1</sup> published a theory on the motion of a top containing a rigidly-spinning inviscid liquid in a cylindrical cavity; this theory is equally applicable to shell and gyroscopes. In conjunction with this theory the gyroscope provides an excellent laboratory tool for studying the yawing motion of a spinning liquid-filled shell.

Stewartson predicted the existence of instabilities in the motion of the top due to resonances between oscillations of the liquid and nutation of the top. Ward<sup>2</sup> experimentally confirmed the presence of two of the predicted instabilities in a gyroscope, though his results differed in detail from the prediction. Experiments conducted at the BRL by Karpov<sup>3,4</sup> with liquid-filled shell and with liquid-filled gyroscopes also confirmed the presence of instabilities, but showed a strong dependence of the growth rate of the instabilities on the viscosity of the liquid. Wedemeyer<sup>5,6</sup> developed a theory of viscous corrections to Stewartson's theory which predicted viscous effects of the nature of those found by Karpov; his comparison of the theory with Karpov's experiments was flawed, as discussed below. Frasier and

- 
1. K. Stewartson, "On the Stability of a Spinning Top Containing Liquid," Journal of Fluid Mechanics, Vol. 5, Part 4, September 1959, pp. 577-592.
  2. G. N. Ward, Appendix to Reference 1.
  3. B. G. Karpov, "Dynamics of a Liquid-Filled Shell: Resonance and the Effects of Viscosity," BRL Report No. 1279, U.S. Army Ballistic Research Laboratory, Aberdeen Proving Ground, Maryland, May 1965. AD 468654.
  4. B. G. Karpov, "Liquid Filled Gyroscope: The Effect of Reynolds Number on Resonance," BRL Report No. 1302, U.S. Army Ballistic Research Laboratory, Aberdeen Proving Ground, Maryland, October 1965. AD 479430.
  5. E. H. Wedemeyer, "Dynamics of Liquid-Filled Shell: Theory of Viscous Corrections to Stewartson's Stability Problem," BRL Report No. 1287, U.S. Army Ballistic Research Laboratory, Aberdeen Proving Ground, Maryland, June 1965. AD 472474.
  6. E. H. Wedemeyer, "Viscous Corrections to Stewartson's Stability Criterion," BRL Report No. 1325, U.S. Army Ballistic Research Laboratory, Aberdeen Proving Ground, Maryland, June 1966. AD 489687.



Scott<sup>7</sup> developed a theory analogous to Stewartson's for a gyroscope with a solid rod concentric with the cylindrical cavity. They predicted that the presence of the rod primarily would change the natural frequencies of the liquid, the motion itself remaining similar to that without the rod. Frasier<sup>8</sup> applied Wedemeyer's theory of viscous corrections to this case and performed gyroscope experiments to check the theory.

Karpov and Wedemeyer used the works mentioned above, plus others, as the foundation for Ref. 9, the handbook for liquid-filled projectile design. Ref. 9 presents theoretical and experimental results as well as operational formulas intended for use by designers in assessing the stability of liquid-filled projectiles. Since the preparation of the handbook, D'Amico<sup>10</sup>, Scott and D'Amico<sup>11</sup>, and Kitchens (unpublished) have performed experiments in which growth rates of the unstable motions of liquid-filled gyroscopes were measured. The object of most of these experiments was to observe changes in growth rate with large amplitude of the motion, and no comparison has been reported between the results of these experiments and the linear, small amplitude theory of Stewartson-Wedemeyer, though such comparison is possible.

## B. Purpose of This Report

Wedemeyer's theory of viscous corrections for solid-body rotation consists of two distinct parts: (1) a theory of viscous effects on oscillations of the liquid, and (2) a theory of the response of the gyroscope to the oscillations. At the time Karpov<sup>4</sup> was reporting his final experiments, only the second part of the theory had been developed--Wedemeyer could predict the motion of the gyroscope given the oscillations of the liquid, but could not accurately predict the frequencies and damping factors of these oscillations.

7. J. T. Frasier and W. E. Scott, "Dynamics of a Liquid-Filled Shell: Cylindrical Cavity With a Central Rod," BRL Report No. 1391, U.S. Army Ballistic Research Laboratory, Aberdeen Proving Ground, Maryland, October 1968. AD 667365.
8. J. T. Frasier, "Dynamics of a Liquid-Filled Shell: Viscous Effects in a Cylindrical Cavity With a Central Rod," BRL Memorandum Report No. 1959, U.S. Army Ballistic Research Laboratory, Aberdeen Proving Ground, Maryland, January 1969. AD 684344.
9. Engineering Design Handbook, Liquid-Filled Projectile Design, AMC Pamphlet No. 706-165, U.S. Army Materiel Development and Readiness Command, Washington, D. C., April 1969. AD 853719.
10. W. P. D'Amico, "Inertial Mode Corrections for the Large Amplitude Motion of a Liquid-Filled Gyroscope," PhD Thesis, University of Delaware, Newark, Delaware, June 1977.
11. W. E. Scott and W. P. D'Amico, "Amplitude-Dependent Behavior of a Liquid Filled Gyroscope," J. Fluid Mech., Vol. 60, Part 4, October 1973, pp. 751-758.

Karpov used his measurements of the motion of the gyroscope and the second part of the theory to find the liquid frequencies and damping factors at resonance, as explained in Section 5 of Ref. 4. Fig. 3 of this reference shows the resulting damping factors. Karpov used these values and the second part of the theory (Eq. (5) in Ref. 4) to compute the growth rate of the motion of the gyroscope away from resonance. This calculated growth rate is shown by the solid curves in Figs. 4 and 5 of Ref. 4; the circles in those figures are data. Because it was necessary to use the measured resonance growth rate itself in predicting other growth rates, the theoretical results could only predict the shape of the growth rate (vs. an appropriate parameter) curve in the neighborhood of resonance. There was no check of the magnitude of the growth rate at any frequency.

Fig. 1 of Ref. 6 presents the same information as Figs. 4 and 5 of Ref. 4. Thus, despite the statements at the bottom of p. 22 of Ref. 6, these figures present only a very limited check of theory with experiment. These same diagrams are presented as Fig. 6-2 of Ref. 9; in the text preceding the figure (Section 6-4) a succinct explanation is given of the way in which the solid curves were actually computed. Note that in this explanation, the relation\*

$$[|D|/(\sigma L)]^{1/2} = 1.6 \times 10^{-3}$$

is given as descriptive of the cylinder. The meaning of this quantity will be explained later; what is of significance here is that for the reported experiment, it was not constant, varying by more than a factor of two over the experimental range. Thus, the first part of Wedemeyer's theory has not been checked at all against Karpov's data, and the second part has not been checked consistently.

Frasier modified the theory for the rodded case<sup>b</sup> by Wedemeyer's viscous correction technique. The comparison between the modified theory and experimental data is flawed, however, because the theory was not correctly evaluated. A discussion of the nature of the error is deferred until Section III.

The experiments conducted after the release of the liquid-filled projectile handbook, Ref. 9, have not been used to check Wedemeyer's theory, in part because they were intended for other purposes. Thus, because of the difficulties with Karpov's and Frasier's comparisons, the situation exists that the theory, which forms a substantial part of the handbook, has never been adequately checked against experimental data, though data are available.

The primary purpose of this report is to present a comparison of the theory with all of the data from gyroscope experiments conducted

---

\* *Definitions are given in List of Symbols section, p. 33.*

at BRL, so that a proper assessment of its validity can be made. In addition, some significant misstatements and errors in equations in Ref. 9 are pointed out and corrected.

## II. THEORY

### A. Equations of Motion of the Gyroscope

A brief sketch of the theory is given here; the reader is referred to Refs. 1, 6, 7, and 9 for details. The purpose here is to show where the theory is susceptible to experimental confirmation.

The gyroscope, shown schematically in Fig. 1, consists of (1) a rotor spinning around its symmetry axis at angular speed  $\Omega$ , and (2) mounts which allow the rotor ( $z'$ ) axis to yaw about a fixed line ( $z$ -axis) through the "point of support" (the point defined by the intersection of lines drawn through the gimbal pivots). Let the  $(x,y,z)$  coordinate system be an inertial system with the  $x$ -axis passing through the outer gimbal pivots and the  $z$ -axis parallel to gravity. Let the non-rotating  $(x',y',z')$  coordinate system be attached to the inner gimbal mount in such a way that when the  $z$  and  $z'$  axes coincide, the  $x$  and  $x'$  and  $y$  and  $y'$  axes also coincide.

Fig. 2 shows coordinates (the  $x'$  and  $y'$  axes being omitted for the sake of clarity). The  $z'$ -axis is coning about the  $z$ -axis at a small yaw angle,  $\alpha(t)$ , where  $\alpha \ll 1$ . The yawing motion of the gyroscope is described by the component angles  $\theta_x$  and  $\theta_y$  of the projection of the end point of a unit vector in the  $z'$ -direction upon the  $x$ - $y$  plane, as shown in the figure. We combine these components in the complex yaw  $\theta = \theta_x + i \theta_y$ .

The liquid is confined in a cylindrical cavity whose symmetry axis coincides with that of the rotor; the radius of the cavity is  $a$ , and the length is  $2c$ . For a partially-filled cavity, the fraction of fill is  $1 - b^2/a^2$ , where  $b$  is the inner radius of a concentric annulus with volume equal to that of the liquid. In the case of a rodded cylinder, the air core is replaced by a rigid rod of radius  $d$ .

There are two torques acting on the gyroscope, the first caused by gravity acting on the mass of the gyroscope, and the second caused by the liquid. Assuming small  $\theta$ , we denote the first moment by  $M_0 \theta$  and the second moment by  $\Gamma^* \theta$ , where  $M_0$  is a real constant ( $= 0$  when the pivot point and center of mass coincide) and  $\Gamma^*$  ( $\theta, d\theta/dt$ ) is a complex function. The equation of motion of the gyroscope when  $|\theta|$  is small (see, e.g., pp. 2-14 and 3-11 in Ref. 9) is

$$T \frac{d^2\theta}{dt^2} - iL\Omega \frac{d\theta}{dt} - M_0 \theta = - \overset{*}{\Gamma} (\theta, d\theta/dt) \theta \quad , \quad (1)$$

where  $L$  is the axial moment of inertia of the gyroscope, and  $T$  is the transverse moment of inertia about the pivot point. The moments of inertia about the  $x'$  - and  $y'$  -axes must be approximately equal here; see p. 2-13 of Ref. 9 for discussion.

Because of the dependence of  $\overset{*}{\Gamma}$  on  $\theta$ , Eq. (1) is non-linear; the solution to an initial value problem cannot in general be constructed by linear combination of independent solutions.\*

### B. Exponential Solutions

For certain values of the complex constant  $\tau$ , possible solutions of Eq. (1) are

$$\theta = \theta_0 \exp (i \tau \Omega t) \quad . \quad (2)$$

These solutions constitute the bases of the Stewartson-Wedemeyer analyses, particularly in regard to establishing criteria for stable motion. The permissible values of  $\tau$  are found by substituting Eq. (2) into Eq. (1), which gives

$$T \tau^2 - L \tau + (M_0/\Omega^2) = \overset{*}{\Gamma} (\tau)/\Omega^2 \quad . \quad (3)$$

Once the liquid moment function,  $\overset{*}{\Gamma} (\tau)$ , is provided, Eq. (3) is solved for  $\tau$ .

Let  $\tau = \tau_R + i \tau_I$ .\*\* Eq. (2) then represents an angular motion, here called coning motion, of constant frequency,  $\tau_R \Omega$ , which decays with time at the rate  $\tau_I \Omega$  if  $\tau_I$  is positive, but grows in amplitude and becomes unstable if  $\tau_I$  is negative. The quantity  $-\tau_I$  is called the "yaw growth rate", and its measurement is the primary objective of gyroscope experiments.

---

\* In this regard the statement following Eq. (4-17) in Ref. 9 is misleading.

\*\* In the original inviscid perturbation theory of Stewartson,  $\tau$  is real for certain regions in parameter space; see the un-numbered equation preceding Eq. (5.12) in Ref. 1.

The forcing term on the right-hand side of Eq. (1) is (1) zero if the gyroscope is empty, and (2) negligible if  $\tau_R$  is not near any natural frequency,  $\tau_{00}$ , of free oscillation of the liquid (see bottom p. 10 of Ref. 6), i.e., away from resonance. For either of these conditions, Eq. (3) has two real solutions, denoted by  $\tau_n$  and  $\tau_p$  (nutational and precessional frequencies, respectively, of the gyroscope):

$$\tau_n = [L/(2T)] [1 + (1 - \beta)^{1/2}] \quad (4)$$

$$\tau_p = [L/(2T)] [1 - (1 - \beta)^{1/2}]$$

where

$$\beta = 4 M_o T / (L\Omega)^2 \quad (5)$$

In these situations,  $\theta(t)$  is a linear combination of  $\exp(i \tau_n \Omega t)$  and  $\exp(i \tau_p \Omega t)$ .

The basis for the prediction of yaw growth rate is the premise that near resonance the motion of the gyroscope with liquid is dominated, over a significant time interval, by a single mode of the form

$$\theta = \theta_o \exp(i \tau_R \Omega t) \exp(-\tau_I \Omega t) \quad , \quad (6)$$

where  $\tau_I$  is negative. This premise is supported by experimental evidence and the conclusions of Stewartson-Wedemeyer theories. Then the amplitude of the yaw should behave as

$$\ln(\text{modulus } [\theta_{\text{meas}}]) \cong \text{const} - \tau_I \Omega t \quad , \quad (6a)$$

which represents a straight line whose slope provides  $\tau_I$ .

### C. Evaluation of the Liquid Moment

Determination of the moment exerted by the liquid on the gyroscope requires solving the appropriate equations of motion for the liquid, subject to boundary conditions determined by the position and motion of the rotor. The solution to these equations yield pressure; integration of the pressure, with the appropriate moment arm,



over the inner surface of the rotor would give the liquid moment.\* To the authors' knowledge no one has actually carried out this integration. The integration can be avoided in the region of resonance ( $\tau_R \approx \tau_{00}$ ) by employing an approximation of Stewartson<sup>1</sup>.

### C.1. Inviscid Theory: Approximation Near Resonance.

The moment exerted by an inviscid liquid is very small unless the coning frequency  $\tau$  is near one of the liquid natural frequencies  $\tau_0$ . If  $\tau$  is near  $\tau_0$ , i.e.,  $|\tau_R - \tau_0|$  and  $|\tau_I| \ll 1$ , then  $\Gamma$  can be approximated in Eq. (3) by

$$\Gamma(\tau) \approx \Omega^2 D(\tau_0) / (\tau - \tau_0) \quad , \quad (7)$$

where  $D$  is the residue of a Laurent series expansion about  $\tau = \tau_0$ . It is convenient to define a non-dimensional quantity  $R$ :

$$R^2 = - D(\tau_0) c / (\rho a^6) \quad . \quad (8)$$

The eigenfrequencies  $\tau_0$  and the residues  $R$  depend only on  $c/a$ ,  $b/a$ , and the azimuthal, axial, and radial wave numbers of the liquid wave:  $m$ ,  $j$ , and  $n$ . Only singly-periodic waves ( $m = 1$ ) contribute to the moment, and only they are considered hereafter.

Tables of  $\tau_0$  and  $2R$  vs  $c/[(2j + 1) a]$  and  $b^2/a^2$  are presented in Ref. 1\*\* for cylinders without a central rod, and in Ref. 7 (d replacing  $b^{***}$ ) for cylinders with a central rod. Expanded versions of both tables are presented in Ref. 9.

### C.2. Viscous Correction for Large Reynolds Number

For quantitative purposes the effect of viscosity cannot be neglected in the prediction of eigenfrequencies, and consequently, of yaw growth rates. Wedemeyer<sup>6</sup> demonstrated that for large Reynolds numbers,  $Re (\equiv a\Omega^2/\nu)$ , a viscous correction to the inviscid eigenfrequency can be derived. In the formalism of his treatment, the

---

\* We note that minus signs should appear before the integrals on the right-hand sides of Eqs. (3-31) and (3-30a) in Ref. 9.

\*\* In Ref. 1, Tables 1-5, the column labeled "R" should be labeled "2R".

\*\*\* The " $b^2/a^2$ " labeling on pp. 53-67 of Ref. 7 should be replaced by " $d^2/a^2$ ".

viscous eigenfrequency  $\tau_{OV} (\equiv \tau_{OO} + i\delta)$  is complex, with a viscous damping factor  $\delta$ ;  $\tau_{OO}$  differs from  $\tau_o$ . The presence of boundary layers on the cylinder walls effectively changes the cavity dimensions to  $a-\delta a$ ,  $c-\delta c$ , and  $d+\delta d$ , where the complex increments  $\delta a$ ,  $\delta c$ , and  $\delta d$  are given by\*:

$$\delta a/a = (2\text{Re})^{-1/2} (1+i) (1-\tau_o)^{-1/2} \quad (9a)$$

$$\delta c/c = \frac{(2\text{Re})^{-1/2}}{2(1-\tau_o)} \frac{a}{c} \left[ \frac{(1-i)(3-\tau_o)}{(1+\tau_o)^{1/2}} - \frac{(1+i)(1+\tau_o)}{(3-\tau_o)^{1/2}} \right] \quad (9b)$$

$$\delta d/d = a/d (\delta a/a) \quad (9c)$$

The viscous eigenfrequency is then obtained formally as a first-order correction to  $\tau_o$ . For a cylinder with no central rod,

$$\tau_{OV} = \tau_o + \left[ \frac{c}{a(2j+1)} \frac{\partial \tau_o}{\partial [c/a(2j+1)]} \right] \left[ \frac{\delta a}{a} - \frac{\delta c}{c} \right] + \left[ \frac{2b^2}{a^2} \frac{\partial \tau_o}{\partial (b^2/a^2)} \right] \frac{\delta a}{a} \quad (10)$$

For a cylinder with a central rod

$$\tau_{OV} = \tau_o + \frac{c}{a(2j+1)} \frac{\partial \tau_o}{\partial (ca^{-1} \{2j+1\}^{-1})} \left[ \frac{\delta a}{a} - \frac{\delta c}{c} \right] + \frac{2d^2}{a^2} \frac{\partial \tau_o}{\partial (d^2/a^2)} \left[ \frac{\delta a}{a} + \frac{\delta d}{d} \right] \quad (11)$$

---

\* Wedemeyer denotes the argument in the right-hand side of Eqs. (17) and (19) of Ref. 6 by  $\tau$ , calling it the "dimensionless frequency of oscillation". Here he is dealing with free oscillations of the liquid, so  $\tau$  should be set equal to  $\tau_o$ . In Ref. 9, Eqs. (6-13) and (6-14) also contain the argument  $\tau$ , but the succeeding statement "with  $\tau = \omega/\Omega$ , the dimensionless yawing frequency" is incorrect; however, in the example at the top of p. 6-8,  $\tau$  is properly set equal to  $\tau_o$ .

The effect of viscosity on the liquid moment is then approximated in Wedemeyer's theory by replacing  $\tau_o$  in Eq. (7) by  $\tau_{ov}$ , leading to the following new approximation to Eq. (3):

$$T \tau^2 - L \tau + (M_o/\Omega^2) = D (\tau_o) / [\tau - (\tau_{oo} + i \delta)] \quad (12)$$

#### D. Solutions for $\tau$

Eq. (12) has three complex roots. Because of the approximation, Eq. (7), made in evaluating the liquid moment, only those roots with  $\tau_R \approx \tau_{oo}$  are applicable. If  $\tau \approx \tau_p$  or  $\tau \approx \tau_n$ , the left hand side of Eq. (12) can be approximated by a linear form with an error of  $0 (\tau - \tau_p)^2$  or  $0 (\tau - \tau_n)^2$ , respectively. Then Eq. (12) becomes a quadratic. When  $\tau \approx \tau_p$ , the two roots have positive  $\tau_I$ 's; i.e., the coning motion is damped. When  $\tau \approx \tau_n$ , the solutions are:

$$\tau_R = \frac{1}{2} (\tau_n + \tau_{oo}) \mp \frac{1}{2} \text{sgn}(\hat{n}) \left[ \frac{1}{2} \{ (m^2 + \hat{n}^2)^{\frac{1}{2}} - m \} \right]^{\frac{1}{2}} \quad (13)$$

$$\tau_I = \frac{1}{2} \delta \pm \frac{1}{2} \left[ \frac{1}{2} \{ (m^2 + \hat{n}^2)^{\frac{1}{2}} + m \} \right]^{\frac{1}{2}} \quad (14)$$

where

$$\sigma = (1 - \beta)^{\frac{1}{2}}$$

$$m = - [4 D(\tau_o) / (\sigma L)] + \delta^2 - (\tau_n - \tau_{oo})^2 \text{ ---assumed } > 0$$

$$\hat{n} = 2 \delta (\tau_n - \tau_{oo}).$$

The lower signs in Eqs. (13) and (14) yield negative  $\tau_I$ , and are thus the signs to use to describe unstable motion of the gyroscope.

Eqs. (13) and (14) are presented as Eqs. (6-7) and (6-8) in Ref. 9. In Ref. 9, Eq. (6-7) is incorrect in that the factor "sgn( $\hat{n}$ )", appearing in Eq. (13), is missing from the right-hand side. Additionally, Eq. (6-6) and the definition of  $n(=\hat{n})$  are inconsistent. Appendix A presents a derivation of Eqs. (13) and (14).

#### E. Review of Assumptions

It is important to carry out experiments under conditions which do not violate the assumptions of the theory with which measurements will



be compared. It is now proper to state or restate some of the important assumptions inherent in the theory:

1. The rotor cavity is a right circular cylinder (no rounded corners).
2. The unperturbed motion of the liquid is solid-body rotation; also the spin rate is large enough so that in a partially-filled cylinder the void forms a cylinder concentric with the rotor cavity.
3. The Reynolds number of the flow,  $Re (\equiv a\Omega^2/\nu)$ , is very large. Viscous effects are thus confined to thin boundary layers.
4. The coning angle of the gyroscope,  $|\theta|$ , is small, producing a small perturbation in the solid-body rotation of the fluid.
5. The gyroscope motion is given by Eq. (6), and the perturbed liquid motion has the same exponential dependence on time. This implies that there is an interval of time in which the motion of the coupled gyroscope-liquid system is independent of the realistic initial conditions but satisfies the small amplitude restriction.
6. The coning frequency is in the neighborhood of a liquid eigenfrequency.
7. The liquid mass is much smaller than the mass of the gyroscope. This condition furnishes a simplification in the liquid moment determination.
8. The transverse moments of inertia about the  $x'$  - and  $y'$  - axes are approximately equal to each other.

### III. THE EXPERIMENTS

#### A. Description

The experiments which will be presented here are those of Karpov<sup>4</sup>, Frasier<sup>8</sup>, D'Amico<sup>10</sup>, Scott and D'Amico<sup>11</sup>, and Kitchens (unpublished). All of these experiments were performed at BRL using a gyroscope like that described in Ref. 4.

Two points to be noted are that: (1) only one flexural pivot was equipped with a strain gauge, so that only one component of the coning motion was measured; there was no check made of the assumption of circular coning (see Section II-B); (2) the coning motion of the empty gyroscope was observed to be damped. It was assumed that the observed growth rate of the coning motion of the filled gyroscope ( $\tau_{obs}$ ) could be expressed as the sum of the damping rate of the empty gyroscope ( $\tau_{empty}$ ) and the growth rate of a frictionless filled

gyroscope, i.e.

$$\tau_{\text{obs}} = \tau_{\text{empty}} + \tau_I \quad (15)$$

This assumption appears reasonable, although it neglects any interactive effect between mechanical friction and presence of fluid. Thus, the experimental values of yaw growth rate recorded in this report are  $\tau_I$ , corresponding to the theoretical  $\tau_I$  of Eq. (14), not the directly measured growth rates. Records indicate that a measured value of  $\tau_{\text{empty}} \Omega = 0.017 \text{ s}^{-1}$  was used for several of the experiments, so that  $\tau_{\text{empty}} \approx 0.324 \times 10^{-4}$  for  $\Omega = 523.6 \text{ rad/sec}$ , the value used in the experiments.

The electrical signal from the strain gauge was recorded on an oscillograph. Since the output of the strain gauge was linear with angular displacement of the flexural pivot, the oscillograph record yielded a plot of coning angle versus time. A set of amplitude readings from the oscillograph record was plotted logarithmically against time. These points fell about a straight line (Eq. (6a)), until the amplitude reached, typically, one degree. The observed yaw growth rate was determined as the slope of this line. The frequency  $\tau_R$  of the coning motion was measured by counting the number of oscillations between two known times on the oscillograph record. The rotational speed of the cylinder was measured with a stroboscope.

At this late date it is difficult to ascertain the errors of past measurements. A study of these experiments yields estimated relative errors of 2% and 3% for  $\tau_R$  and  $\tau_I$ , respectively. These are the errors indicated by the error bars in the figures in this section; the apparent scatter in the data seems to be consistent with these estimates. Estimated errors for cylinder dimensions and fluid parameters are as follows:

|   |        |
|---|--------|
| Aspect Ratio of Cylinder (c/a)                      | 1/2-1% |
| $b^2/a^2$ (or $d^2/a^2$ )                           | 2%     |
| Reynolds Number (Re)                                | 5%     |
| Liquid Density/Axial Moment of Inertia ( $\rho/L$ ) | 1%     |

Except for the error in aspect ratio, the effects of these errors on computation of  $\tau_I$  are small. The effect of the error in c/a can be significant, as discussion in Section III-B will demonstrate.

There is a division between Karpov's experiment and the others, in that Karpov used constant values of  $L$  and  $\tau_n$ , varying the fill ratio of the cylinder (hence the liquid eigenfrequency), while the other experiments varied  $L$  and  $\tau_n$  while maintaining constant fill ratio. Karpov made separate measurements of  $\tau_R$  and  $\tau_I$  as functions of  $b^2/a^2$ . The others made simultaneous measurements of  $\tau_R$  and  $\tau_I$  as functions of  $L$  and  $\tau_n$ , though unfortunately they did not measure or record  $L$  or  $\tau_n$ . This latter fact prevents a full comparison of their experimental data with the theory. The nature of the comparison which can be made is indicated in Section III-C. The Reynolds number was varied by using liquids of varying viscosity, keeping the cylinder speed fixed at 523.6 rad/s. This means that there was no check of the effect of gravity in the experiments with the partially-filled cylinder. Details of cylinder dimensions, liquid properties, moments of inertia, etc., and the measured values of  $\tau_R$  and  $\tau_I$  are tabulated in Appendix B.

## B. The Results of Karpov

Figs. 3 and 4 present  $\tau_R$  and  $-\tau_I$  for the mode  $n = j = 1$  plotted against  $b^2/a^2$  for the two liquids that Karpov used, labeled #1 ( $Re = 5.2 \times 10^5$ ) and #2 ( $Re = 5.2 \times 10^3$ ). The experimental values are indicated by circles and diamonds. The theoretical values, solid curves, are obtained from Eqs. (13) and (14). The plots of  $-\tau_I$  against  $b^2/a^2$  are analogous to Figs. 4 and 5 in Ref. 4, Fig. 1 in Ref. 6, and Fig. 6-2 in Ref. 9, where the abscissa is the parameter  $\tau_0$ . The significant difference between these figures and Figs. 3 and 4 is that the latter two contain true theoretical curves, as opposed to semi-empirical curves in the former (discussed in Section I).

The predicted trend of  $\tau_R$  seems to appear in the data, as does the "jump" at  $b^2/a^2 \approx 0.15$  for liquid #1. However, the data are consistently about 3% higher than the theoretical predictions.

For the  $Re = 5.2 \times 10^5$  case, the measured values of  $\tau_I$  agree with the predicted values to within the estimated error. For the  $Re = 5.2 \times 10^3$  case, the measured peak value of  $\tau_I$  is about 10% greater than the prediction, and there is an apparent shift of the measured curve to the left of the theoretical curve. A study of the sensitivity of  $\tau_I$  to small changes in aspect ratio was made with the intention of determining whether this shift could be explained by uncertainties in aspect ratio measurements. In Figure 5,  $\tau_I$  vs  $b^2/a^2$  curves are shown for  $c/a$  greater and less than the experimental aspect ratio by 1/2 percent. For the less viscous fluid, the curves bracket the data; the apparent discrepancy between the experimental and theoretical peaks is not significant.

For liquid #2, the conclusion is not as definite. A positive correction of 1/2 percent to the aspect ratio brings the theoretical and experimental values of  $\tau_I$  into closer agreement, including the positions of the peaks; however, the theoretical curve exhibits considerably more asymmetry about the peak than do the data.

### C. Results of D'Amico, Kitchens, and Frasier

The quantities  $\tau_n$  and L were not recorded for these experiments. Fortunately, the ring combinations used were recorded, and all of the rings, rotor, and cylinder are extant, so that measurements could be made of L. However, T (or equivalently,  $\tau_n = L/T$ ) corresponding to the experimental conditions could not be determined because the location of the counterweight used to adjust the position of the center of gravity of the gyroscope was not recorded.

In a particular set of experiments, L and  $\tau_n$  were varied for each case, so that  $\tau_n = \tau_n(L)$ . Since the  $\tau_n$ 's in these experiments were not recorded,  $\tau_R$  and  $\tau_I$  could not be evaluated by Eqs. (13) and (14) explicitly in terms of measured  $\tau_n$ . The relationship  $\tau_n(L)$  was produced indirectly by solving Eq. (13) numerically for  $\tau_n$  for all pairs of measured L and  $\tau_R$ , and fairing curves through the plotted  $\tau_n$  vs L points. In most cases, one straight line fitted the points quite well, the r.m.s. error of L about the line being about 1/2% of the mean. These points correspond to changes in the increment rings only (see Appendix B). In two experiments, however, the main ring was changed to extend the range of L, producing a discontinuity in the  $\tau_n$  vs L curve; in these cases the points were fitted with two straight lines, one for each main ring. This fit led to discontinuities in the curves of  $\tau_I$  vs  $\tau_R$  (Figs. 6 and 7).

Values of  $\tau_R$  and  $\tau_I$  were then evaluated by Eqs. (13) and (14) for each series of L's employed in the experiments, and plots of  $\tau_I$  vs  $\tau_R$  were drawn, which could be compared directly with experiment. These plots do not provide a total check of the theory, since part of the input ( $\tau_n$ ) was based on the prior assumption of the theory's validity.

It was stated in Section I that Frasier's comparison of his data<sup>8</sup> to the theory was flawed; the nature of the flaw is now clear. Since neither  $\tau_n$  nor L was measured during his experiments (except that a single "nominal" L was noted), he could not have correctly evaluated Eq. (14) to find  $\tau_I$ . It seems likely that he did what later experimenters did; namely, use  $\tau_R$  in place of  $\tau_n$  in Eq. (14).



Figs. 6 to 10 present plots of  $-\tau_I$  vs  $\tau_R$  for all of the experiments, including four different liquids at 79% fill, two liquids at 100% fill, and three liquids in a rodded cylinder. The error bars indicate  $\pm 2\%$  error in  $\tau_R$  and  $\pm 3\%$  error in  $\tau_I$ . General comments about the agreement between theory and experiment are that: (1) the amplitude at the peak value of  $\tau_I$  agrees to within 10% when  $Re \geq 4 \times 10^4$ ; (2) the amplitude at the peak agrees within 25% at lower Reynolds numbers; (3) in general, the theory predicts a more rapid decay away from the peak than was observed, particularly to the right of the peak. In most of the figures, there is a suggestion of a shifting of the predicted peak response to the left or to the right of the observed peak. However, Fig. 11, showing the effect of a  $\pm 1/2\%$  change in aspect ratio on two of the curves, demonstrates that the apparent shifts are not significant.

#### IV. CONCLUDING REMARKS

Renewed emphasis is currently being placed on research into the dynamics of liquid-filled shell, in particular by means of gyroscope experiments. In the planning of future work, it is necessary to have a clear picture of what has been accomplished in the past. Examination of available records and reports has revealed inadequacies in the results of previous investigators, such as incomplete recording of data (e.g., moments of inertia) and misleading comparisons of theoretical and experimental results. This report was written in an effort to provide a correct and unified picture of past work.

Comparisons show that predicted and measured frequencies of greatest instability of motion agree to within the experimental error; the growth rates at those frequencies agree to within 10% for  $Re > 10^4$ , and to within 25% for lower Reynolds number. All work discussed here was performed with the liquid completely spun-up; i.e., in rigid body rotation. The conclusions in Ref. 9 based on this work are valid; namely, that free-oscillation frequencies of the liquid are well-predicted by the Stewartson-Wedemeyer theory, and that coning frequencies and yaw growth rates near resonance agree qualitatively with theoretical predictions. However, the experiments on which these conclusions are based cover only a small range of coning frequencies, ratios of liquid mass to solid mass, and aspect ratios, and, additionally, only a single rotation speed. Also, no direct measurement has been made of the motion of the liquid. Therefore, further work is required in this area to obtain a more distinct quantitative picture of the effect of the liquid on the stability of the shell.

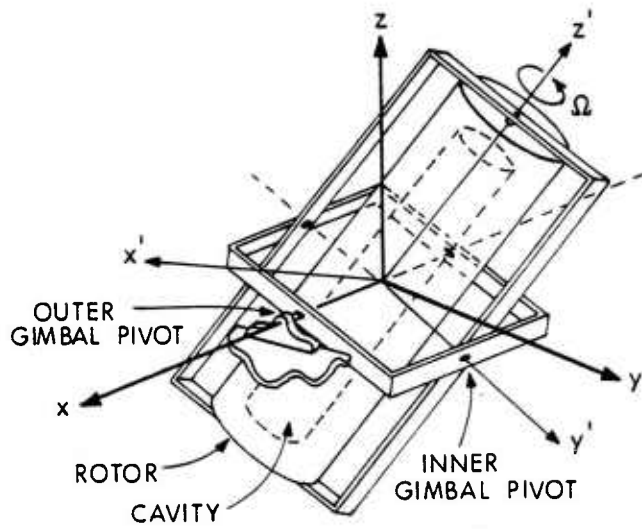

Figure 1. Schematic Diagram of Gyroscope

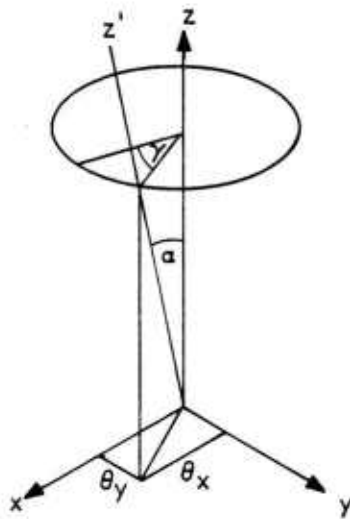

Figure 2. Schematic Diagram of Coordinates

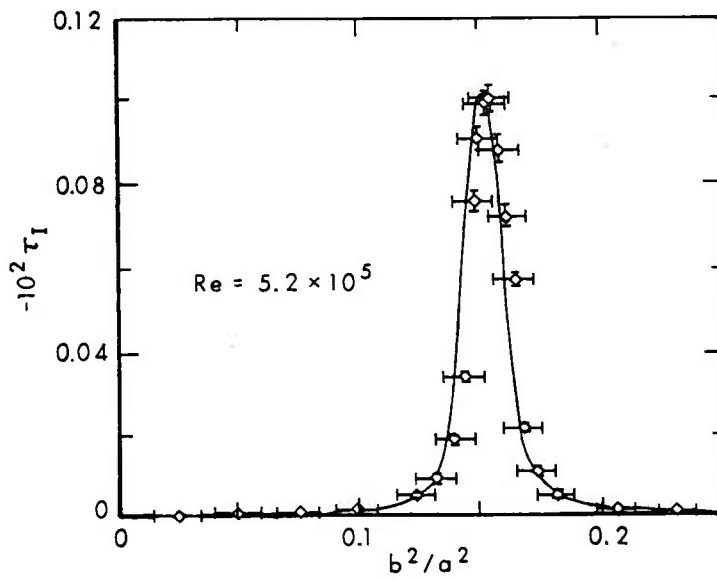
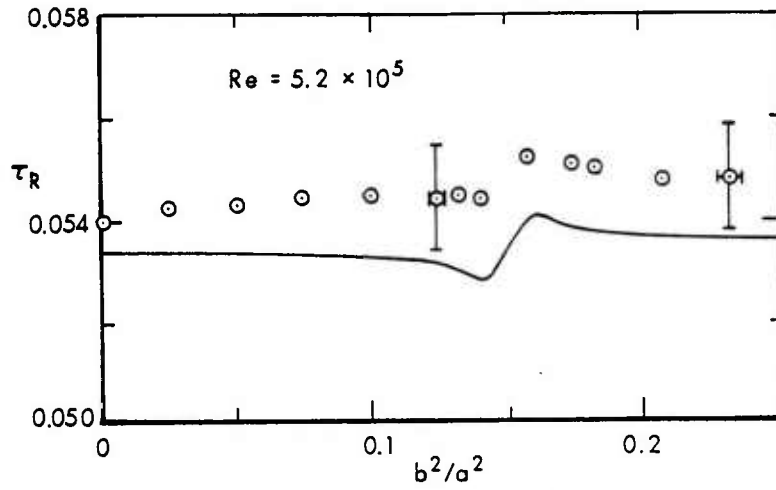

Figure 3. Coning Frequencies and Yaw Growth Rates for Karpov Liquid #1 Experiments ( $a = 3.150$  cm,  $c = 9.691$  cm,  $\rho = 0.818$  g/cm<sup>3</sup>,  $L = 1.968 \times 10^5$  g cm<sup>2</sup>,  $\nu = 0.01$  cm<sup>2</sup>/s,  $\tau_n = 0.0534$ ;  $n = 1, j = 1$ )

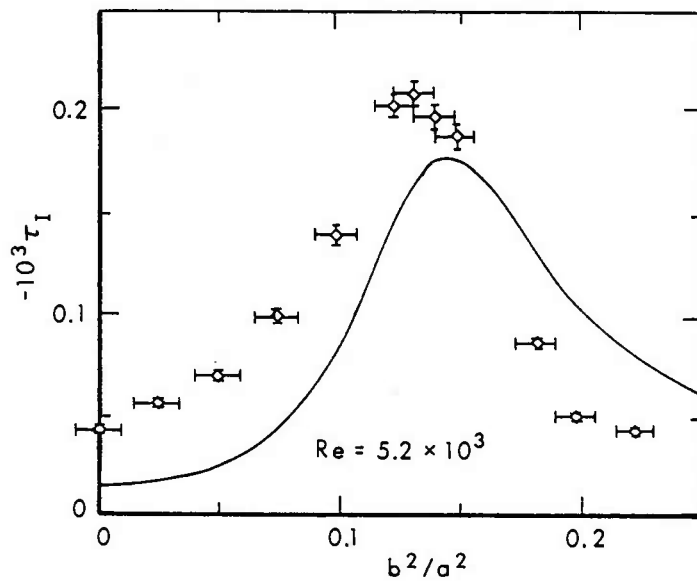
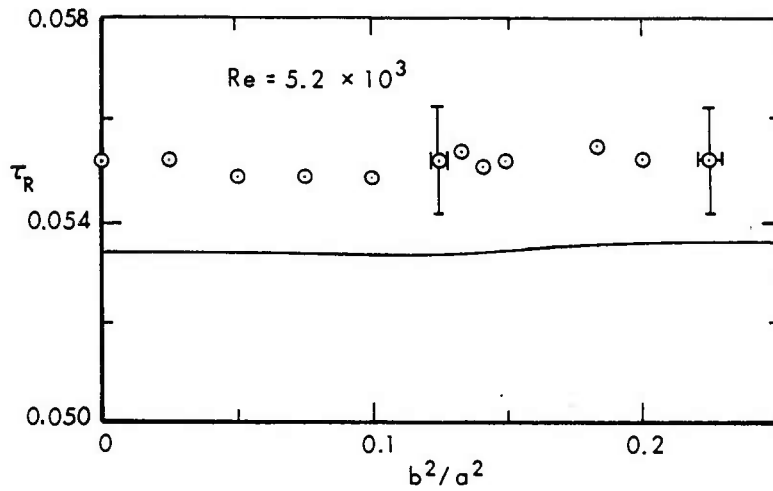

Figure 4. Coning Frequencies and Yaw Growth Rates for Karpov Liquid #2 Experiments ( $a = 3.150$  cm,  $c = 9.691$  cm,  $\rho = 0.818$  g/cm<sup>3</sup>,  $L = 1.968 \times 10^5$  g cm<sup>2</sup>,  $\nu = 1.00$  cm<sup>2</sup>/s,  $\tau_n = 0.0534$ ;  $n = 1, j = 1$ )



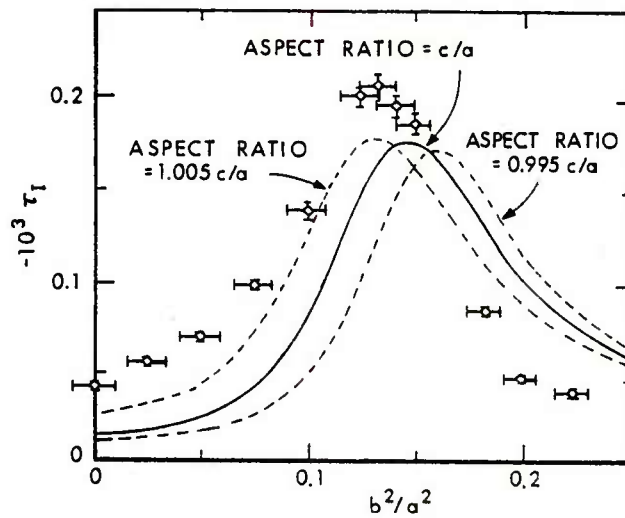
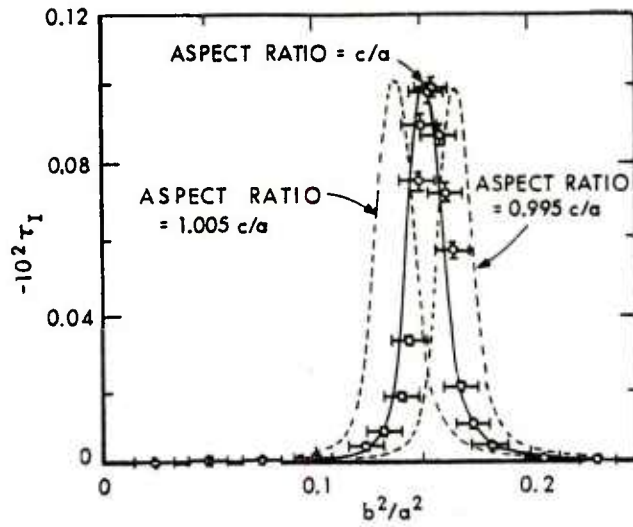

Figure 5. Sensitivity of Yaw Growth Rate to Change in Cylinder Aspect Ratio in Karpov's Experiments ( $a = 3.150$  cm,  $c = 9.691$  cm,  $L = 1.968 \times 10^5$  g cm<sup>2</sup>,  $\tau_n = 0.0534$ ;  $n = 1$ ,  $j = 1$ )

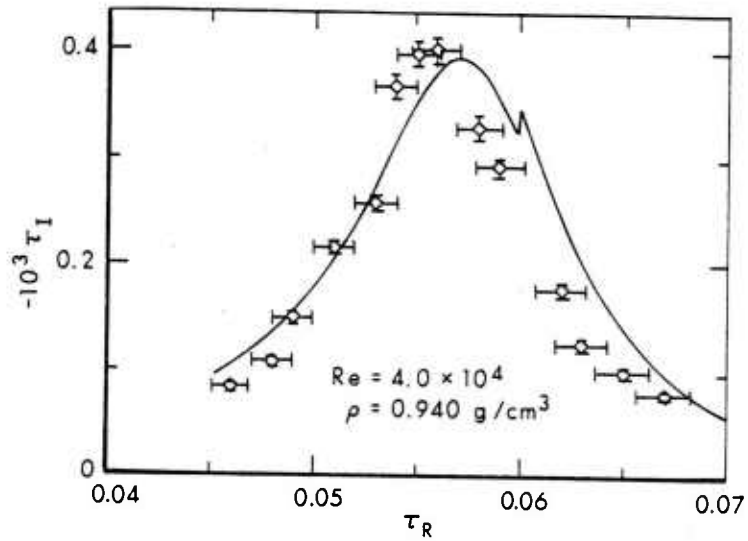
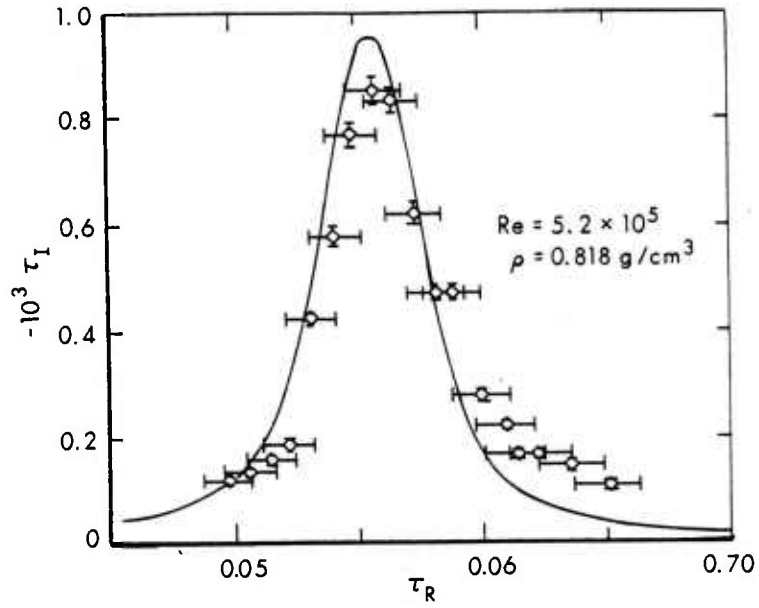

Figure 6.  $-\tau_I$  vs  $\tau_R$  for D'Amico's 79% Filled Cylinder Experiments,  $Re = 5.2 \times 10^5$  and  $Re = 4.0 \times 10^4$  ( $a = 3.153 \text{ cm}$ ,  $c = 9.500 \text{ cm}$ ,  $(b/a)^2 = 0.210$ ;  $n = 1$ ,  $j = 1$ )

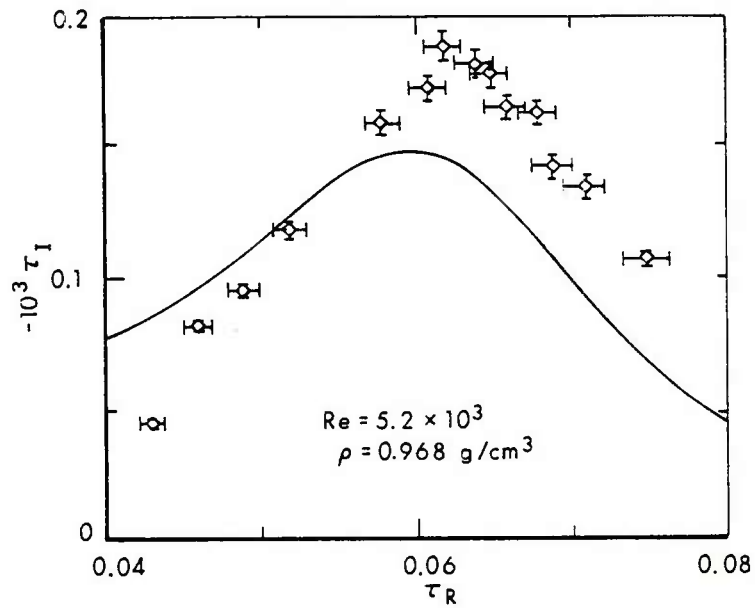
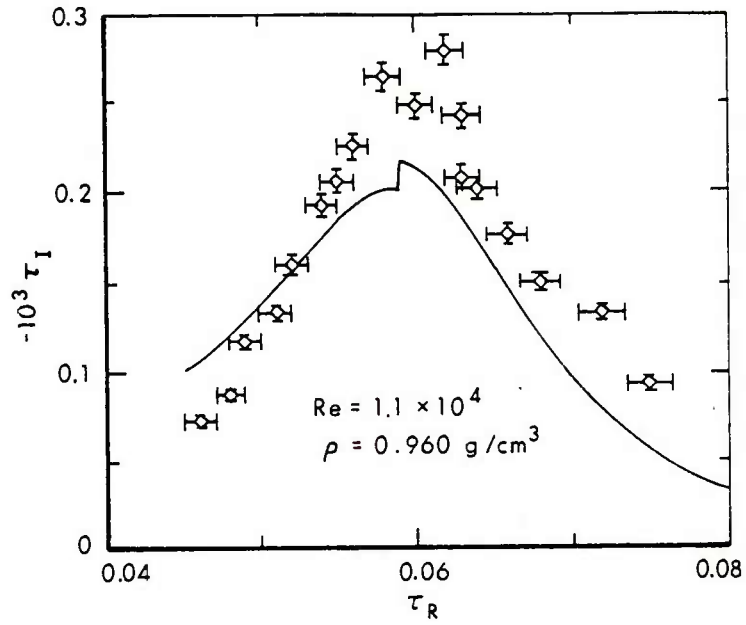

Figure 7.  $-\tau_I$  vs  $\tau_R$  for D'Amico's 79% Filled Cylinder Experiments,  $Re = 1.1 \times 10^4$  and  $Re = 5.2 \times 10^3$  ( $a = 3.153 \text{ cm}$ ,  $c = 9.500 \text{ cm}$ ,  $(b/a)^2 = 0.210$ ;  $n = 1$ ,  $j = 1$ )

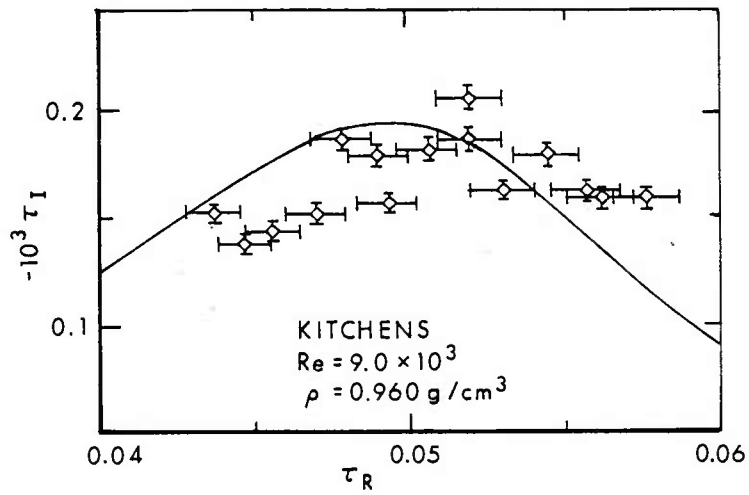
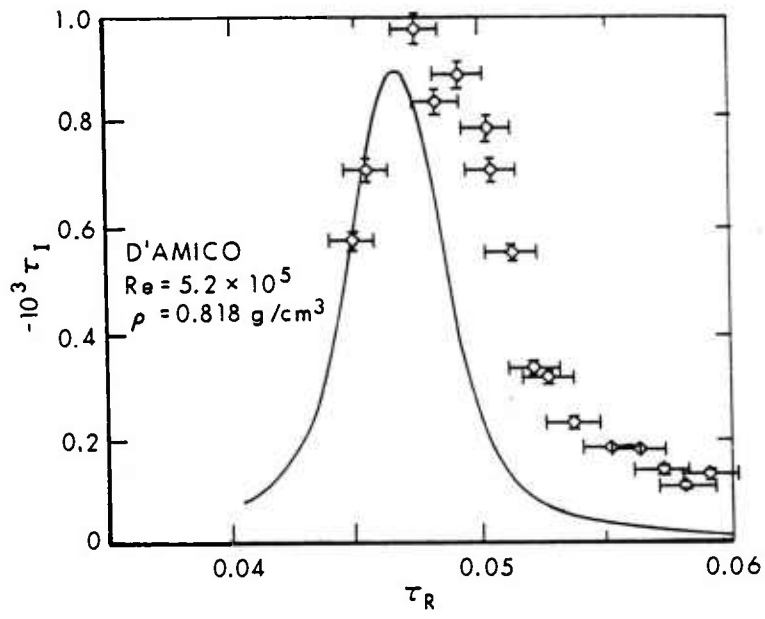

Figure 8. -  $\tau_I$  vs  $\tau_R$  for 100% Filled Cylinders, Experiments of D'Amico and Kitchens ( $a = 3.153 \text{ cm}$ ,  $c = 9.928 \text{ cm}$ ;  $n = 1$ ,  $j = 1$ )

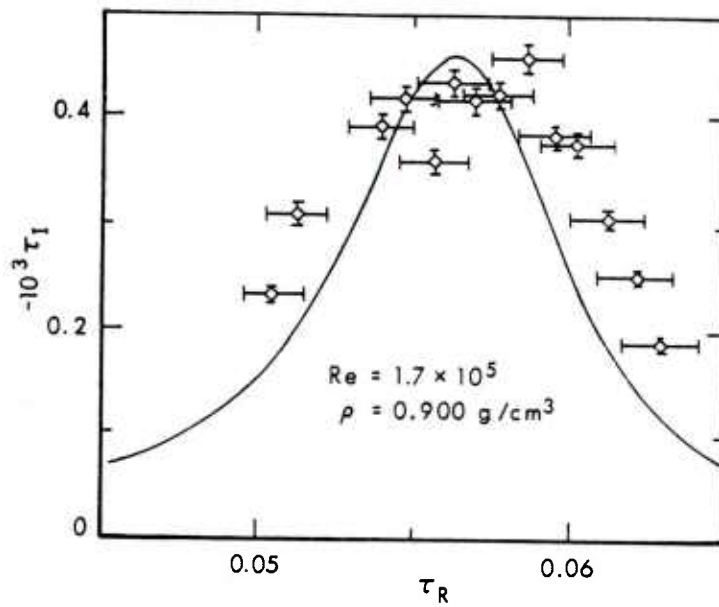
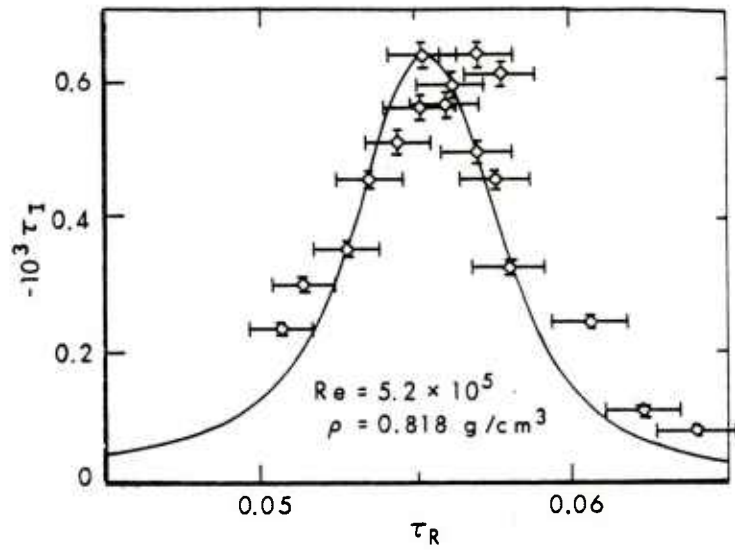

Figure 9.  $-\tau_I$  vs  $\tau_R$  for Frasier (Rod) Experiments,  $Re = 5.2 \times 10^5$   
 and  $Re = 1.70 \times 10^5$  ( $a = 3.153 \text{ cm}$ ,  $c = 9.030 \text{ cm}$ ,  
 $(d/a)^2 = 0.023$ ;  $n = 1$ ,  $j = 1$ )

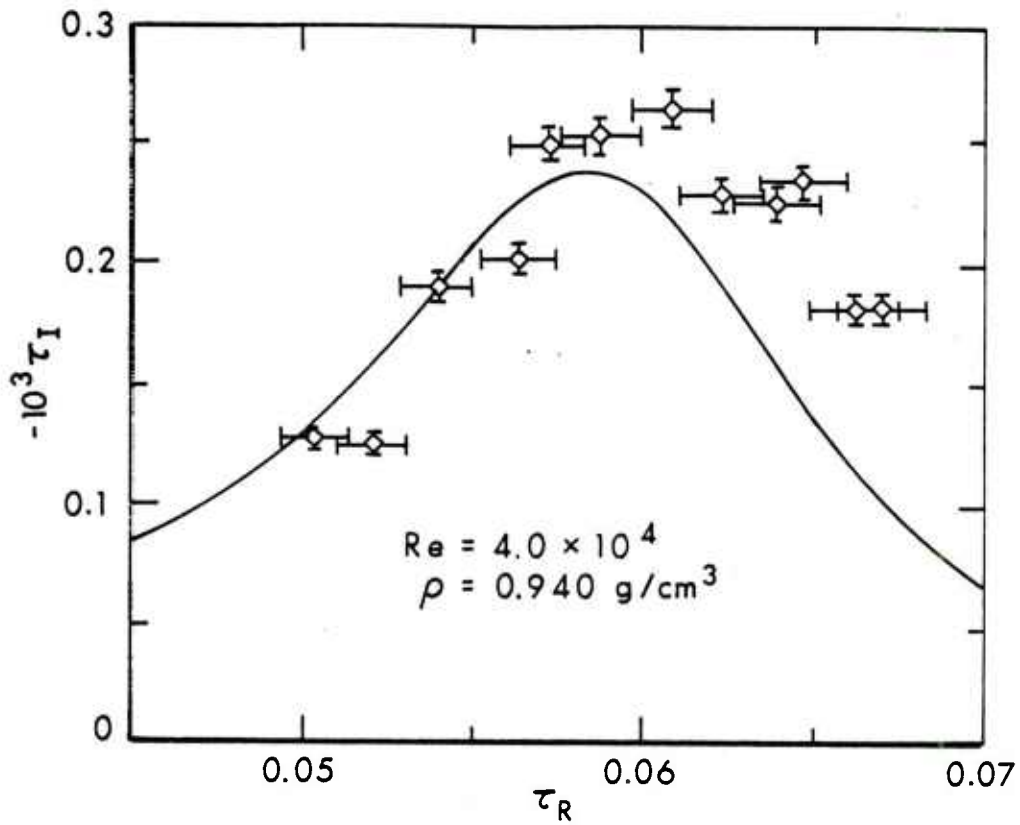
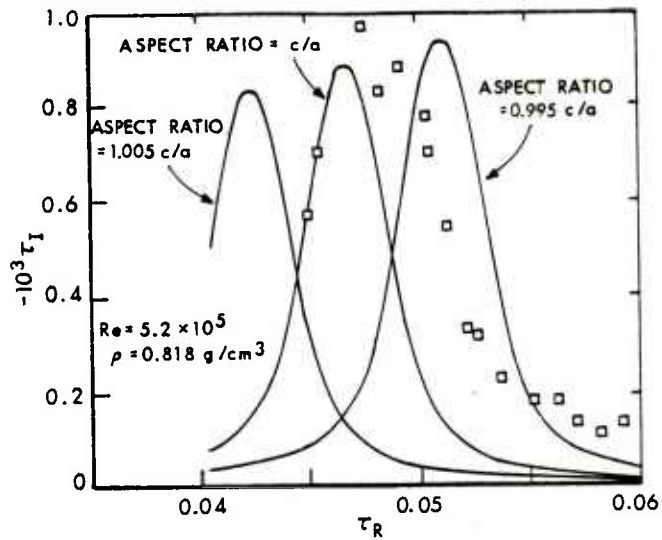
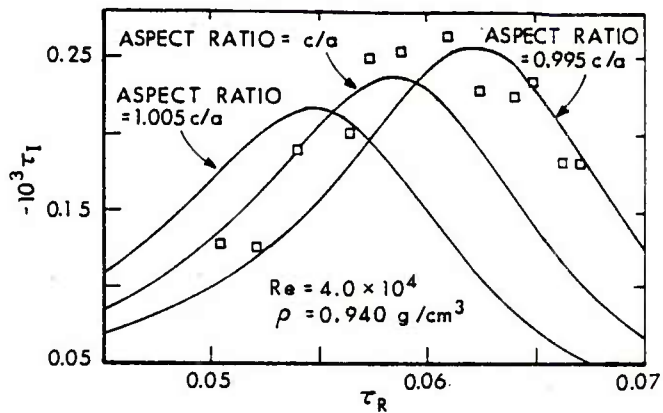

Figure 10.  $-\tau_I$  vs  $\tau_R$  for Frasier (Rod) Experiments,  $Re = 4.0 \times 10^4$   
 ( $a = 3.153 \text{ cm}$ ,  $c = 9.030 \text{ cm}$ ,  $(d/a)^2 = 0.023$ ;  $n = 1$ ,  
 $j = 1$ )



(a)



(b)

Figure 11. Sensitivity of  $-\tau_I$  vs  $\tau_R$  Curves to Change in Cylinder Aspect Ratio: (a) D'Amico 100% Filled Cylinder,  $a = 3.153 \text{ cm}$ ,  $c = 9.928 \text{ cm}$ ,  $j = 1$ ,  $n = 1$ ; (b) Frasier Cylinder With Inner Burster,  $a = 3.153 \text{ cm}$ ,  $c = 9.030 \text{ cm}$ ,  $(d/a)^2 = 0.02$ ,  $n = 1$ ,  $j = 1$

## REFERENCES

1. K. Stewartson, "On the Stability of a Spinning Top Containing Liquid," *J. Fluid Mech.*, Vol. 5, Part 4, September 1959, pp. 577-592.
2. G. N. Ward, Appendix to Reference 1.
3. B. G. Karpov, "Dynamics of a Liquid-Filled Shell: Resonance and the Effects of Viscosity," BRL Report No. 1279, U.S. Army Ballistic Research Laboratory, Aberdeen Proving Ground, Maryland, May 1965. AD 468654.
4. B. G. Karpov, "Liquid Filled Gyroscope: The Effect of Reynolds Number on Resonance," BRL Report No. 1302, U.S. Army Ballistic Research Laboratory, Aberdeen Proving Ground, Maryland, October 1965. AD 479430.
5. E. H. Wedemeyer, "Dynamics of Liquid-Filled Shell: Theory of Viscous Corrections to Stewartson's Stability Problem," BRL Report No. 1287, U.S. Army Ballistic Research Laboratory, Aberdeen Proving Ground, Maryland, June 1965. AD 472474.
6. E. H. Wedemeyer, "Viscous Corrections to Stewartson's Stability Criterion," BRL Report No. 1325, U.S. Army Ballistic Research Laboratory, Aberdeen Proving Ground, Maryland, June 1966. AD 489687.
7. J. T. Frasier and W. E. Scott, "Dynamics of a Liquid-Filled Shell: Cylindrical Cavity With a Central Rod," BRL Report No. 1391, U.S. Army Ballistic Research Laboratory, Aberdeen Proving Ground, Maryland, October 1968. AD 667365.
8. J. T. Frasier, "Dynamics of a Liquid-Filled Shell: Viscous Effects in a Cylindrical Cavity With a Central Rod," BRL Memorandum Report No. 1959, U.S. Army Ballistic Research Laboratory, Aberdeen Proving Ground, Maryland, January 1969. AD 684344.
9. Engineering-Design Handbook, Liquid-Filled Projectile Design, AMC Pamphlet No. 706-165, U.S. Army Materiel Development and Readiness Command, Washington, D. C., April 1969. AD 853719.
10. W. P. D'Amico, "Inertial Mode Corrections for the Large Amplitude Motion of a Liquid-Filled Gyroscope," PhD Thesis, University of Delaware, Newark, Delaware, June 1977.
11. W. E. Scott and W. P. D'Amico, "Amplitude-Dependent Behavior of a Liquid Filled Gyroscope," *J. Fluid Mech.*, Vol. 60, Part 4, October 1973, pp. 751-758.



## LIST OF SYMBOLS

|                                |  |
|--------------------------------|--|
| a                              | cross-sectional radius of cylindrical cavity (cm)  |
| b                              | radial coordinate of free surface in partially-filled cylinder (cm)  |
| c                              | half-height of cylindrical cavity (cm)   |
| d                              | cross-sectional radius of inner burster (cm)   |
| D                              | liquid moment residue function, Eq. (7) ( $\text{g cm}^2$ )  |
| j                              | index of axial perturbation mode   |
| L                              | axial moment of inertia of empty gyroscope ( $\text{g cm}^2$ )   |
| $M_O$                          | moment function due to displacement of center of mass from pivot point, Eq. (1) ( $\text{g cm}^2/\text{s}^2$ ) |
| n                              | index of radial perturbation mode  |
| R                              | liquid moment residue function, Eq. (8) (non-dimensional)  |
| Re                             | ( $\equiv a\Omega^2/\nu$ ) Reynolds number (non-dimensional)   |
| t                              | time (s)   |
| T                              | transverse moment of inertia of empty gyroscope about axis through pivot point ( $\text{g cm}^2$ )             |
| x, y, z                        | laboratory fixed rectangular coordinates, z-axis coinciding with unyawed cylinder axis, Figs. 1 and 2 (cm)     |
| $x', y', z'$                   | non-rotating rectangular coordinates, $z'$ -axis coinciding with yawing cylinder axis, Figs. 1 and 2 (cm)      |
| $\alpha$                       | coning angle, Fig. 2 (radians)   |
| $\beta$                        | $\equiv 4 M_O T / (L\Omega)^2$ (non-dimensional)   |
| $\delta$                       | viscous perturbation decay rate/ $\Omega$ (non-dimensional)  |
| $\delta a, \delta c, \delta d$ | effective changes to a, c, and d due to boundary layers, Eq. (9) (cm)  |
| $\Gamma$                       | liquid moment function of $\tau$ in Eq. (3) ( $\text{g cm}^2/\text{s}^2$ )                                     |
| $\Gamma^*$                     | liquid moment function in Eq. (1) ( $\text{g cm}^2/\text{s}^2$ )   |

LIST OF SYMBOLS (continued)

|  |   |
|--|---|
| $\theta (\equiv \theta_x + i\theta_y)$ | complex yaw ( $\theta_x$ and $\theta_y$ being x and y components, respectively) (non-dimensional) |
| $\nu$                                  | kinematic viscosity of liquid ( $\text{cm}^2/\text{s}$ )  |
| $\rho$                                 | density of liquid ( $\text{g}/\text{cm}^3$ )  |
| $\sigma$                               | $\equiv (1 - \beta)^{1/2}$  |
| $\tau (\equiv \tau_R + i\tau_I)$       | exponent term in exponential solution, Eq. (2)  |
| $\tau_o$                               | inviscid perturbation eigenfrequency/ $\Omega$ (non-dimensional)                                  |
| $\tau_{oo}$                            | viscous perturbation eigenfrequency/ $\Omega$ (non-dimensional)                                   |
| $\tau_{ov}$                            | $\equiv \tau_{oo} + i \delta$ , Eq. (10)  |
| $\tau_I$                               | - (yaw growth rate)/ $\Omega$ (non-dimensional)   |
| $\tau_n$                               | nutational frequency of empty gyroscope/ $\Omega$ , Eq. (4)<br>(non-dimensional)                  |
| $\tau_p$                               | precessional frequency of empty gyroscope/ $\Omega$ , Eq. (4)<br>(non-dimensional)                |
| $\tau_R$                               | coning frequency of liquid-filled gyroscope (non-dimensional)                                     |
| $\Omega$                               | spin rate of cylinder (radians/s)   |

APPENDIX A: DERIVATION OF EQUATIONS (13) AND (14)

We start with Eq. (6-2) of Ref. 9:

$$\tau = (1/2)(\tau_n + \tau_{ov}) \pm \{ [(1/2)(\tau_n - \tau_{ov})]^2 - |D|/(\sigma L) \}^{1/2} \quad (A.1)$$

Recalling that  $\tau_{ov} = \tau_{oo} + i\delta$ , Eq. (A.1) can be written

$$\begin{aligned} \tau = (1/2)(\tau_n + \tau_{oo}) + (1/2)i\delta \pm (1/2)i \{ (4|D|)/(\sigma L) + \delta^2 - (\tau_n - \tau_{oo})^2 \\ + 2i\delta (\tau_n - \tau_{oo}) \}^{1/2} \end{aligned} \quad (A.2)$$

If we now define

$$m = (4|D|)/(\sigma L) + \delta^2 - (\tau_n - \tau_{oo})^2$$

and 
$$\tilde{n} = 2\delta (\tau_n - \tau_{oo}),$$

where  $m > 0$  for the ranges of parameters considered. Eq. (A.2) can be written

$$\tau = (1/2)(\tau_n + \tau_{oo}) + (1/2)i\delta \pm (1/2)i (m + i\tilde{n})^{1/2} \quad (A.3)$$

This corresponds to Eq. (6-6) in Ref. 9, with  $\tilde{n}$  replacing  $n$ . Note that Eq. (6-6) of the reference is in error, given the definition of  $n$  there.

Let 
$$m + i\tilde{n} \equiv \lambda e^{i\theta}, \quad (A.4)$$

where

$$\lambda^2 = m^2 + \tilde{n}^2, \quad \theta = \tan^{-1}(\tilde{n}/m), \quad \text{sgn}(\theta) = \text{sgn}(\tilde{n}), \quad -\pi < \theta < \pi. \quad (A.5)$$

Then

$$\pm i (m + i\tilde{n})^{1/2} = \pm \lambda^{1/2} [-\sin(\theta/2) + i \cos(\theta/2)].$$

For 
$$-\pi/2 < \theta/2 < \pi/2,$$

$$\sin(\theta/2) = \text{sgn}(\theta) [(1 - \cos \theta)/2]^{1/2},$$

and 
$$\cos(\theta/2) = [(1 + \cos \theta)/2]^{1/2}.$$

Thus

$$\begin{aligned} \pm i (m + i \tilde{n})^{1/2} &= \pm \lambda^{1/2} [-\text{sgn}(\theta) \{(1 - \cos \theta)/2\}^{1/2} \\ &\quad + i \{(1 + \cos \theta)/2\}^{1/2}] \quad . \end{aligned} \quad (\text{A.6})$$

Using the following trigometric identity:

$$\cos (\tan^{-1} x) = (1 + x^2)^{-1/2} \quad \text{for} \quad -\pi/2 < \tan^{-1} x < \pi/2 ,$$

and Eq. (A.5), we get

$$\begin{aligned} \pm i (m + i \tilde{n})^{1/2} &= \pm 2^{-1/2} [-\text{sgn}(\tilde{n}) \{(m^2 + \tilde{n}^2)^{1/2} - m\}^{1/2} \\ &\quad + i \{(m^2 + \tilde{n}^2)^{1/2} + m\}^{1/2}] \quad . \end{aligned} \quad (\text{A.7})$$

Inserting Eq. (A.7) into Eq. (A.3) and separating real and imaginary parts, we get

$$\begin{aligned} \tau_R &= (1/2)(\tau_n + \tau_{oo}) \mp (1/2) \text{sgn}(\tilde{n}) [\{(m^2 + \tilde{n}^2)^{1/2} - m\}/2]^{1/2} \\ \tau_I &= (1/2)\delta \pm (1/2) [\{(m^2 + \tilde{n}^2)^{1/2} + m\}/2]^{1/2} \quad , \end{aligned} \quad (\text{A.8})$$

which are Eqs. (13) and (14) in this report.

## APPENDIX B. DATA FROM EXPERIMENTS

For the convenience of future investigators, relevant data from the experiments described in this report are tabulated here. All frequencies and growth rates listed here were obtained by the original researchers from the raw data; no re-reduction of raw data was performed by the present authors, except to verify the reduction methods.

In all experiments except those of Karpov, the axial moment of inertia of the gyroscope was varied by changing rings mounted on the rotor. These rings were of two types: main rings, in five sizes; and increment rings, in four sizes. At any one time, only one main ring was used, but any or all increment rings could be used. The increment rings were mounted above or below the main rings, the two positions being distinguished as "top" and "bottom" in the experimental records. The axial moments of inertia of the components of the gyroscope were measured by the present authors and are shown in Table B-1, together with the corresponding masses. There were three increment rings of size .001 and two of each of the other sizes. The values shown in Table B-1 represent mean values of the rings of each size.

TABLE B-1. AXIAL MOMENT OF INERTIA OF GYROSCOPE COMPONENTS

| Component            | Mass (g) | Axial Moment of Inertia (g cm <sup>2</sup> ) |
|----------------------|----------|--|
| Steel Rotor          | 2554     | $3.221 \times 10^4$                          |
| Plastic Cylinder     | 933      | 0.841  |
| Main Ring 1          | 1650     | 6.238  |
| Main Ring 2          | 3160     | 13.87  |
| Main Ring 3          | 4455     | 21.74  |
| Main Ring 4          | 6510     | 31.03  |
| Main Ring 5          | 7725     | 39.22  |
| Increment Ring .001  | 180      | 0.48   |
| Increment Ring .002  | 309      | 0.93   |
| Increment Ring .0025 | 367      | 1.10   |
| Increment Ring .005  | 615      | 2.12   |

In the experimental records, numbers are given which indicate the total "value" of the increment rings used. For example, in one case the increments might be recorded as "top-.003, bottom-.005". This could represent any of the combinations shown in Table B-2. Unfortunately, not all of the combinations have the same axial moment of inertia. In this work, wherever there were several possible increment combinations, the mean moment of inertia of the combinations was used. In the worst case, this led to an inaccuracy of less than one percent of the total axial moment of inertia of the gyroscope.

TABLE B-2. INCREMENT RING COMBINATIONS WHICH COULD BE LISTED AS  
 "TOP-.003, BOTTOM-.005"

| Top Increments  | Bottom Increments | Total Axial M.O.I.<br>of Increments ( $\text{g cm}^2$ ) |
|-----------------|-------------------|---|
| .001 , .002     | .005              | $3.53 \times 10^4$                                      |
| .001 , .002     | $2 \times .0025$  | $3.62 \times 10^4$                                      |
| $3 \times .001$ | .005              | $3.56 \times 10^4$                                      |
| $3 \times .001$ | $2 \times .0025$  | $3.65 \times 10^4$                                      |
|                 | Mean              | $3.59 \times 10^4$                                      |

In the following tables, the data describing each experiment are presented. The date indicated for each experiment is approximate.

TABLE B-3. THE EXPERIMENT OF KARPOV (1965)

$a = 3.150 \text{ cm}$                        $c = 9.691 \text{ m}$   
 $\tau_n = 0.0534$                          $L = 1.968 \times 10^5 \text{ g cm}^2$   
 $v = 0.01 \text{ cm}^2/\text{s}^3$                  $v = 1.0 \text{ cm}^2/\text{s}^3$   
 $\rho = 0.818 \text{ g/cm}^3$                   $\rho = 0.968 \text{ g/cm}^3$

| $b^2/a^2$ | $\tau_R$ | $-\tau_I$             | $\tau_R$ | $-\tau_I$             |
|-----------|----------|-----------------------|----------|-----------------------|
| 0         | .0540    |                       | .0552    | $.439 \times 10^{-4}$ |
| .0248     | .0542    | $.038 \times 10^{-4}$ | .0552    | .573                  |
| .0496     | .0543    | .076                  | .0548    | .707                  |
| .0744     | .0545    | .115                  | .0549    | .993                  |
| .0992     | .0545    | .153                  | .0549    | 1.394                 |
| .1240     | .0544    | .458                  | .0552    | 2.024                 |
| .1322     | .0545    | .917                  | .0554    | 2.082                 |
| .1405     | .0544    | 1.872                 | .0551    | 1.967                 |
| .1446     |          | 3.400                 |          |                       |
| .1488     |          | 7.563                 | .0552    | 1.872                 |
| .1504     |          | 9.015                 |          |                       |
| .1537     |          | 9.855                 |          |                       |
| .1554     |          | 9.969                 |          |                       |
| .1570     | .0552    |                       |          |                       |
| .1587     |          | 8.747                 |          |                       |

TABLE B-3. THE EXPERIMENT OF KARPOV (1965) (continued)

| $b^2/a^2$ | $\tau_R$ | $-\tau_I$              | $\tau_R$ | $-\tau_I$             |
|-----------|----------|------------------------|----------|-----------------------|
| .1620     |          | $7.219 \times 10^{-4}$ |          |                       |
| .1653     |          | 5.691                  |          |                       |
| .1686     |          | 2.139                  |          |                       |
| .1736     | .0551    | 1.070                  |          |                       |
| .1818     | .0550    | .477                   | .0555    | $.859 \times 10^{-4}$ |
| .1983     |          |                        | .0552    | .497                  |
| .2066     | .0548    | .095                   |          |                       |
| .2231     |          |                        | .0552    | .420                  |
| .2314     | .0548    | .038                   |          |                       |

TABLE B-4. THE EXPERIMENT OF D'AMICO (1969)

$a = 3.153 \text{ cm}$                        $c = 9.500 \text{ cm}$                        $b^2/a^2 = 0.21$

$$\nu = 0.01 \text{ cm}^2/\text{s} , \quad \rho = 0.818 \text{ g/cm}^3$$

| Main Ring | Increment Top | Rings Bottom | $L(\text{g cm}^2)$ | $\tau_R$ | $-\tau_I$ |
|-----------|---------------|--------------|--------------------|----------|-----------|
| 2         | 0.0000        | 0.0010       | 1.878E+05          | 0.0498   | 1.222E-04 |
| 2         | 0.0010        | 0.0010       | 1.926E+05          | 0.0507   | 1.375E-04 |
| 2         | 0.0020        | 0.0010       | 1.973E+05          | 0.0515   | 1.623E-04 |
| 2         | 0.0020        | 0.0020       | 2.018E+05          | 0.0522   | 1.891E-04 |
| 2         | 0.0025        | 0.0025       | 2.051E+05          | 0.0532   | 4.259E-04 |
| 2         | 0.0025        | 0.0035       | 2.099E+05          | 0.0542   | 5.806E-04 |
| 2         | 0.0035        | 0.0035       | 2.147E+05          | 0.0549   | 7.678E-04 |
| 2         | 0.0045        | 0.0035       | 2.193E+05          | 0.0558   | 8.537E-04 |
| 2         | 0.0040        | 0.0050       | 2.234E+05          | 0.0565   | 8.346E-04 |
| 2         | 0.0050        | 0.0050       | 2.276E+05          | 0.0574   | 6.226E-04 |
| 2         | 0.0050        | 0.0060       | 2.320E+05          | 0.0582   | 4.698E-04 |
| 2         | 0.0060        | 0.0060       | 2.368E+05          | 0.0589   | 4.736E-04 |
| 2         | 0.0060        | 0.0070       | 2.402E+05          | 0.0600   | 2.827E-04 |
| 2         | 0.0070        | 0.0070       | 2.448E+05          | 0.0610   | 2.215E-04 |
| 2         | 0.0075        | 0.0075       | 2.494E+05          | 0.0614   | 1.719E-04 |
| 2         | 0.0085        | 0.0075       | 2.537E+05          | 0.0623   | 1.700E-04 |
| 2         | 0.0085        | 0.0095       | 2.617E+05          | 0.0636   | 1.490E-04 |
| 2         | 0.0105        | 0.0095       | 2.711E+05          | 0.0651   | 1.089E-04 |

TABLE B-4. THE EXPERIMENT OF D'AMICO (1969) (continued)

$$\nu = 0.13 \text{ cm}^2/\text{s} \quad \rho = 0.940 \text{ g/cm}^3$$

| Main Ring | Increment Top | Rings Bottom | L(g cm <sup>2</sup> ) | $\tau_R$ | $-\tau_I$ |
|-----------|---------------|--------------|-----------------------|----------|-----------|
| 2         | 0.0000        | 0.0020       | 1.925E+05             | 0.0460   | 8.594E-05 |
| 2         | 0.0020        | 0.0020       | 2.018E+05             | 0.0480   | 1.089E-04 |
| 2         | 0.0060        | 0.0000       | 2.100E+05             | 0.0490   | 1.509E-04 |
| 2         | 0.0060        | 0.0020       | 2.189E+05             | 0.0510   | 2.177E-04 |
| 2         | 0.0050        | 0.0050       | 2.276E+05             | 0.0530   | 2.597E-04 |
| 2         | 0.0070        | 0.0050       | 2.365E+05             | 0.0540   | 3.686E-04 |
| 2         | 0.0070        | 0.0070       | 2.448E+05             | 0.0550   | 3.992E-04 |
| 2         | 0.0075        | 0.0085       | 2.537E+05             | 0.0560   | 4.030E-04 |
| 2         | 0.0095        | 0.0085       | 2.617E+05             | 0.0580   | 3.304E-04 |
| 2         | 0.0105        | 0.0095       | 2.711E+05             | 0.0590   | 2.941E-04 |
| 3         | 0.0000        | 0.0000       | 2.620E+05             | 0.0620   | 1.776E-04 |
| 3         | 0.0000        | 0.0020       | 2.715E+05             | 0.0630   | 1.261E-04 |
| 3         | 0.0020        | 0.0020       | 2.808E+05             | 0.0650   | 9.931E-05 |
| 3         | 0.0000        | 0.0060       | 2.890E+05             | 0.0670   | 8.021E-05 |

$$\nu = 0.49 \text{ cm}^2/\text{s} , \quad \rho = 0.960 \text{ g/cm}^3$$

| Main Ring | Increment Top | Rings Bottom | L(g cm <sup>2</sup> ) | $\tau_R$ | $-\tau_I$ |
|-----------|---------------|--------------|-----------------------|----------|-----------|
| 2         | 0.0020        | 0.0020       | 2.018E+05             | 0.0460   | 7.257E-05 |
| 2         | 0.0010        | 0.0050       | 2.100E+05             | 0.0480   | 8.785E-05 |
| 2         | 0.0030        | 0.0050       | 2.189E+05             | 0.0490   | 1.165E-04 |
| 2         | 0.0050        | 0.0050       | 2.276E+05             | 0.0510   | 1.337E-04 |
| 2         | 0.0070        | 0.0050       | 2.365E+05             | 0.0520   | 1.604E-04 |
| 2         | 0.0070        | 0.0070       | 2.448E+05             | 0.0540   | 1.929E-04 |
| 2         | 0.0085        | 0.0075       | 2.537E+05             | 0.0550   | 2.063E-04 |
| 2         | 0.0085        | 0.0095       | 2.617E+05             | 0.0560   | 2.254E-04 |
| 2         | 0.0105        | 0.0095       | 2.711E+05             | 0.0580   | 2.655E-04 |
| 3         | 0.0000        | 0.0000       | 2.620E+05             | 0.0600   | 2.483E-04 |
| 3         | 0.0000        | 0.0020       | 2.715E+05             | 0.0620   | 2.807E-04 |
| 3         | 0.0020        | 0.0020       | 2.808E+05             | 0.0630   | 2.426E-04 |
| 3         | 0.0000        | 0.0035       | 2.778E+05             | 0.0630   | 2.082E-04 |
| 3         | 0.0020        | 0.0035       | 2.873E+05             | 0.0640   | 2.024E-04 |
| 3         | 0.0040        | 0.0035       | 2.966E+05             | 0.0660   | 1.776E-04 |
| 3         | 0.0030        | 0.0070       | 3.073E+05             | 0.0680   | 1.509E-04 |
| 3         | 0.0070        | 0.0070       | 3.238E+05             | 0.0720   | 1.337E-04 |
| 3         | 0.0095        | 0.0105       | 3.501E+05             | 0.0750   | 9.358E-05 |



TABLE B-4. THE EXPERIMENT OF D'AMICO (1969) (continued)

$$v = 1.0 \text{ cm}^2/\text{s} , \quad \rho = 0.968 \text{ g/cm}^3$$

| Main Ring | Increment Top | Rings Bottom | L(g cm <sup>2</sup> ) | $\tau_R$ | $-\tau_I$ |
|-----------|---------------|--------------|-----------------------|----------|-----------|
| 2         | 0.0000        | 0.0000       | 1.830E+05             | 0.0430   | 4.584E-05 |
| 2         | 0.0020        | 0.0020       | 2.018E+05             | 0.0460   | 8.212E-05 |
| 2         | 0.0045        | 0.0035       | 2.193E+05             | 0.0490   | 9.549E-05 |
| 2         | 0.0060        | 0.0060       | 2.368E+05             | 0.0520   | 1.184E-04 |
| 2         | 0.0075        | 0.0085       | 2.537E+05             | 0.0580   | 1.585E-04 |
| 2         | 0.0095        | 0.0105       | 2.711E+05             | 0.0610   | 1.719E-04 |
| 3         | 0.0000        | 0.0020       | 2.715E+05             | 0.0620   | 1.891E-04 |
| 3         | 0.0020        | 0.0020       | 2.808E+05             | 0.0640   | 1.814E-04 |
| 3         | 0.0025        | 0.0035       | 2.889E+05             | 0.0650   | 1.776E-04 |
| 3         | 0.0045        | 0.0035       | 2.983E+05             | 0.0660   | 1.642E-04 |
| 3         | 0.0050        | 0.0050       | 3.066E+05             | 0.0680   | 1.623E-04 |
| 3         | 0.0050        | 0.0070       | 3.155E+05             | 0.0690   | 1.413E-04 |
| 3         | 0.0070        | 0.0070       | 3.238E+05             | 0.0710   | 1.337E-04 |
| 3         | 0.0105        | 0.0095       | 3.501E+05             | 0.0750   | 1.070E-04 |

TABLE B-5. THE EXPERIMENT OF D'AMICO (1974)

$$a = 3.153 \text{ cm} \quad c = 9.928 \text{ cm} \quad b^2/a^2 = 0$$

$$v = 0.01 \text{ cm}^2/\text{s} , \quad \rho = 0.818 \text{ g/cm}^3$$

| Main Ring | Top    | Bottom | L(g cm <sup>2</sup> ) | $\tau_R$ | $-\tau_I$ |
|-----------|--------|--------|-----------------------|----------|-----------|
| 2         | 0.0000 | 0.0000 | 1.830E+05             | 0.0450   | 5.730E-04 |
| 2         | 0.0010 | 0.0000 | 1.878E+05             | 0.0456   | 7.066E-04 |
| 2         | 0.0010 | 0.0010 | 1.926E+05             | 0.0476   | 9.778E-04 |
| 2         | 0.0020 | 0.0010 | 1.973E+05             | 0.0484   | 8.346E-04 |
| 2         | 0.0020 | 0.0020 | 2.018E+05             | 0.0493   | 8.862E-04 |
| 2         | 0.0020 | 0.0030 | 2.066E+05             | 0.0504   | 7.811E-04 |
| 2         | 0.0020 | 0.0030 | 2.066E+05             | 0.0506   | 7.028E-04 |
| 2         | 0.0030 | 0.0030 | 2.112E+05             | 0.0514   | 5.500E-04 |
| 2         | 0.0035 | 0.0035 | 2.147E+05             | 0.0523   | 3.304E-04 |
| 2         | 0.0035 | 0.0045 | 2.193E+05             | 0.0528   | 3.151E-04 |
| 2         | 0.0050 | 0.0050 | 2.276E+05             | 0.0538   | 2.292E-04 |
| 2         | 0.0050 | 0.0060 | 2.320E+05             | 0.0553   | 1.814E-04 |
| 2         | 0.0060 | 0.0060 | 2.368E+05             | 0.0564   | 1.757E-04 |
| 2         | 0.0060 | 0.0070 | 2.402E+05             | 0.0573   | 1.375E-04 |
| 2         | 0.0070 | 0.0070 | 2.448E+05             | 0.0583   | 1.089E-04 |
| 2         | 0.0070 | 0.0080 | 2.496E+05             | 0.0593   | 1.318E-04 |

TABLE B-6. THE EXPERIMENT OF KITCHENS (1976)

$a = 3.153 \text{ cm}$

$c = 9.928 \text{ cm}$

$b^2/a^2 = 0$

$\nu = 0.58 \text{ cm}^2/\text{s}$

$\rho = 0.960 \text{ g/cm}^3$

| Main Ring | Increment Top | Rings Bottom | $L(\text{g cm}^2)$ | $\tau_R$ | $-\tau_I$ |
|-----------|---------------|--------------|--------------------|----------|-----------|
| 2         | 0.0000        | 0.0010       | 1.878E+05          | 0.0437   | 1.53E-04  |
| 2         | 0.0000        | 0.0020       | 1.925E+05          | 0.0447   | 1.39E-04  |
| 2         | 0.0010        | 0.0020       | 1.973E+05          | 0.0456   | 1.45E-04  |
| 2         | 0.0020        | 0.0020       | 2.018E+05          | 0.0470   | 1.53E-04  |
| 2         | 0.0030        | 0.0020       | 2.066E+05          | 0.0478   | 1.88E-04  |
| 2         | 0.0030        | 0.0030       | 2.112E+05          | 0.0490   | 1.80E-04  |
| 2         | 0.0020        | 0.0050       | 2.147E+05          | 0.0493   | 1.58E-04  |
| 2         | 0.0030        | 0.0050       | 2.189E+05          | 0.0506   | 1.83E-04  |
| 2         | 0.0040        | 0.0050       | 2.234E+05          | 0.0519   | 2.08E-04  |
| 2         | 0.0050        | 0.0050       | 2.276E+05          | 0.0519   | 1.88E-04  |
| 2         | 0.0050        | 0.0060       | 2.320E+05          | 0.0530   | 1.64E-04  |
| 2         | 0.0060        | 0.0060       | 2.368E+05          | 0.0544   | 1.81E-04  |
| 2         | 0.0070        | 0.0060       | 2.402E+05          | 0.0557   | 1.64E-04  |
| 2         | 0.0070        | 0.0070       | 2.448E+05          | 0.0562   | 1.61E-04  |
| 2         | 0.0080        | 0.0070       | 2.496E+05          | 0.0576   | 1.61E-04  |

TABLE B-7. THE EXPERIMENT OF FRASIER (1968)

a = 3.153 cm                      c = 9.030 cm

Central Rod:  $d^2/a^2 = .023$

$\nu = 0.01 \text{ cm}^2/\text{s}$  ,                       $\rho = 0.818 \text{ g/cm}^3$

| Main Ring | Increment Top | Rings Bottom | L(g cm <sup>2</sup> ) | $\tau_R$ | $-\tau_I$ |
|-----------|---------------|--------------|-----------------------|----------|-----------|
| 2         | 0.0000        | 0.0000       | 1.830E+05             | 0.0507   | 2.349E-04 |
| 2         | 0.0010        | 0.0000       | 1.878E+05             | 0.0514   | 2.998E-04 |
| 2         | 0.0010        | 0.0020       | 1.973E+05             | 0.0528   | 3.533E-04 |
| 2         | 0.0020        | 0.0020       | 2.018E+05             | 0.0536   | 4.600E-04 |
| 2         | 0.0030        | 0.0020       | 2.066E+05             | 0.0545   | 5.138E-04 |
| 2         | 0.0025        | 0.0035       | 2.099E+05             | 0.0552   | 5.615E-04 |
| 2         | 0.0035        | 0.0025       | 2.099E+05             | 0.0553   | 6.398E-04 |
| 2         | 0.0035        | 0.0035       | 2.147E+05             | 0.0560   | 5.672E-04 |
| 2         | 0.0035        | 0.0035       | 2.147E+05             | 0.0562   | 5.940E-04 |
| 2         | 0.0035        | 0.0045       | 2.193E+05             | 0.0570   | 4.966E-04 |
| 2         | 0.0035        | 0.0045       | 2.193E+05             | 0.0570   | 6.398E-04 |
| 2         | 0.0045        | 0.0045       | 2.239E+05             | 0.0576   | 4.584E-04 |
| 2         | 0.0045        | 0.0045       | 2.239E+05             | 0.0578   | 6.092E-04 |
| 2         | 0.0050        | 0.0050       | 2.276E+05             | 0.0580   | 3.285E-04 |
| 2         | 0.0060        | 0.0060       | 2.368E+05             | 0.0606   | 2.464E-04 |
| 2         | 0.0070        | 0.0070       | 2.448E+05             | 0.0623   | 1.146E-04 |
| 2         | 0.0075        | 0.0085       | 2.537E+05             | 0.0640   | 8.212E-05 |

$\nu = 0.03 \text{ cm}^2/\text{s}$  ,                       $\rho = 0.900 \text{ g/cm}^3$

| Main Ring | Increment Top | Rings Bottom | L(g cm <sup>2</sup> ) | $\tau_R$ | $-\tau_I$ |
|-----------|---------------|--------------|-----------------------|----------|-----------|
| 2         | 0.0000        | 0.0000       | 1.830E+05             | 0.0505   | 2.311E-04 |
| 2         | 0.0000        | 0.0010       | 1.878E+05             | 0.0513   | 3.075E-04 |
| 2         | 0.0020        | 0.0020       | 2.018E+05             | 0.0540   | 3.915E-04 |
| 2         | 0.0025        | 0.0025       | 2.051E+05             | 0.0547   | 4.183E-04 |
| 2         | 0.0035        | 0.0025       | 2.099E+05             | 0.0557   | 3.591E-04 |
| 2         | 0.0035        | 0.0035       | 2.147E+05             | 0.0563   | 4.335E-04 |
| 2         | 0.0035        | 0.0045       | 2.193E+05             | 0.0570   | 4.163E-04 |
| 2         | 0.0045        | 0.0045       | 2.239E+05             | 0.0578   | 4.221E-04 |
| 2         | 0.0045        | 0.0055       | 2.287E+05             | 0.0587   | 4.584E-04 |
| 2         | 0.0050        | 0.0060       | 2.320E+05             | 0.0596   | 3.820E-04 |
| 2         | 0.0060        | 0.0060       | 2.368E+05             | 0.0603   | 3.762E-04 |
| 2         | 0.0060        | 0.0070       | 2.402E+05             | 0.0613   | 3.056E-04 |
| 2         | 0.0070        | 0.0070       | 2.448E+05             | 0.0622   | 2.502E-04 |
| 2         | 0.0070        | 0.0075       | 2.473E+05             | 0.0630   | 1.872E-04 |

TABLE B-7. THE EXPERIMENT OF FRASIER (1963) (continued)

$$\nu = 0.13 \text{ cm}^2/\text{s} , \quad \rho = 0.940 \text{ g/cm}^3$$

| Main Ring | Increment Top | Rings Bottom | L(g cm <sup>2</sup> ) | $\tau_R$ | $-\tau_I$ |
|-----------|---------------|--------------|-----------------------|----------|-----------|
| 2         | 0.0000        | 0.0000       | 1.830E+05             | 0.0504   | 1.280E-04 |
| 2         | 0.0000        | 0.0020       | 1.925E+05             | 0.0521   | 1.261E-04 |
| 2         | 0.0020        | 0.0020       | 2.018E+05             | 0.0540   | 1.910E-04 |
| 2         | 0.0035        | 0.0025       | 2.099E+05             | 0.0564   | 2.024E-04 |
| 2         | 0.0035        | 0.0045       | 2.193E+05             | 0.0573   | 2.502E-04 |
| 2         | 0.0050        | 0.0050       | 2.276E+05             | 0.0588   | 2.540E-04 |
| 2         | 0.0050        | 0.0070       | 2.365E+05             | 0.0609   | 2.655E-04 |
| 2         | 0.0070        | 0.0070       | 2.448E+05             | 0.0624   | 2.292E-04 |
| 2         | 0.0075        | 0.0085       | 2.537E+05             | 0.0640   | 2.254E-04 |
| 2         | 0.0085        | 0.0085       | 2.585E+05             | 0.0648   | 2.349E-04 |
| 2         | 0.0095        | 0.0095       | 2.663E+05             | 0.0663   | 1.833E-04 |
| 2         | 0.0105        | 0.0095       | 2.711E+05             | 0.0671   | 1.833E-04 |

DISTRIBUTION LIST

| <u>No. of</u><br><u>Copies</u> | <u>Organization</u>   | <u>No. of</u><br><u>Copies</u> | <u>Organization</u>  |
|--------------------------------|---|--------------------------------|--|
| 12                             | Commander<br>Defense Technical Info Center<br>ATTN: DDC-DDA<br>Cameron Station<br>Alexandria, VA 22314  | 1                              | Director<br>US Army ARRADCOM<br>Benet Weapons Laboratory<br>ATTN: DRDAR-LCB-TL<br>Watervliet, NY 12189   |
| 1                              | Commander<br>US Army Engineer Waterways<br>Experiment Station<br>ATTN: R. H. Malter<br>Vicksburg, MS 39180  | 1                              | Commander<br>US Army Aviation Research<br>and Development Command<br>ATTN: DRSVAV-E<br>P. O. Box 209<br>St. Louis, MO 63166                                |
| 1                              | Commander<br>US Army Materiel Development<br>and Readiness Command<br>ATTN: DRCDMD-ST<br>5001 Eisenhower Avenue<br>Alexandria, VA 22333   | 1                              | Director<br>US Army Air Mobility Research<br>and Development Laboratory<br>ATTN: SAVDL-D, W.J.McCroskey<br>Ames Research Center<br>Moffett Field, CA 94035 |
| 3                              | Commander<br>US Army Armament Research<br>and Development Command<br>ATTN: DRDAR-TSS (2 cys)<br>DRDAR-LC, Dr. J.Frasier<br>Dover, NJ 07801  | 1                              | Commander<br>US Army Communications Rsch<br>and Development Command<br>ATTN: DRDCO-PPA-SA<br>Fort Monmouth, NJ 07703                                       |
| 6                              | Commander<br>US Army Armament Research<br>and Development Command<br>ATTN: DRDAR-LCA-F<br>Mr. D. Mertz<br>Mr. E. Falkowski<br>Mr. A. Loeb<br>Mr. R. Kline<br>Mr. S. Kahn<br>Mr. S. Wasserman<br>Dover, NJ 07801 | 1                              | Commander<br>US Army Electronics Research<br>and Development Command<br>Technical Support Activity<br>ATTN: DELSD-L<br>Fort Monmouth, NJ 07703             |
| 1                              | Commander<br>US Army Armament Materiel<br>Readiness Command<br>ATTN: DRSAR-LEP-L, Tech Lib<br>Rock Island, IL 61299   | 4                              | Commander<br>US Army Missile Command<br>ATTN: DRSMI-R<br>DRSMI-YDL<br>DRSMI-RDK<br>Mr. R. Deep<br>Mr. R. Becht<br>Redstone Arsenal, AL 35809               |

DISTRIBUTION LIST

| <u>No. of<br/>Copies</u> | <u>Organization</u>   | <u>No. of<br/>Copies</u> | <u>Organization</u>  |
|--------------------------|---|--------------------------|--|
| 1                        | Commander<br>US Army Tank Automotive<br>Research & Development Cmd<br>ATTN: DRDTA-UL<br>Warren, MI 48090                    | 2                        | Commander<br>David W. Taylor Naval Ship<br>Research & Development Cmd<br>ATTN: H. J. Lugt, Code 1802<br>S. de los Santos<br>Head, High Speed<br>Aero Division<br>Bethesda, MD 20084                |
| 1                        | Commander<br>US Army Jefferson Proving<br>Ground<br>ATTN: STEJP-TD-D<br>Madison, IN 47250                                   | 1                        | Commander<br>Naval Surface Weapons Center<br>ATTN: DX-21, Lib Br.<br>Dahlgren, VA 22448  |
| 1                        | Commander<br>US Army Research Office<br>ATTN: Dr. R. E. Singleton<br>P. O. Box 12211<br>Research Triangle Park<br>NC 27709  | 5                        | Commander<br>Naval Surface Weapons Center<br>Applied Aerodynamics Division<br>ATTN: K. R. Enkenhus<br>M. Ciment<br>S. M. Hastings<br>A. E. Winklemann<br>W. C. Ragsdale<br>Silver Spring, MD 20910 |
| 1                        | AGARD-NATO<br>ATTN: R. H. Korkegi<br>APO New York 09777   | 1                        | AFATL (DLDL, Dr. D.C. Daniel)<br>Eglin AFB, FL 32542   |
| 1                        | Director<br>US Army TRADOC Systems<br>Analysis Activity<br>ATTN: ATAA-SL, Tech Lib<br>White Sands Missile Range<br>NM 88002 | 2                        | AFFDL (W.L. Hankey; J.S. Shang)<br>Wright-Patterson AFB, OH 45433  |
| 3                        | Commander<br>Naval Air Systems Command<br>ATTN: AIR-604<br>Washington, DC 20360   | 4                        | Director<br>National Aeronautics and<br>Space Administration<br>ATTN: D. R. Chapman<br>J. Rakich<br>W. C. Rose<br>B. Wick<br>Ames Research Center<br>Moffett Field, CA 94035                       |
| 3                        | Commander<br>Naval Ordnance Systems Command<br>ATTN: ORD-0632<br>ORD-035<br>ORD-5524<br>Washington, DC 20360                |                          |  |

DISTRIBUTION LIST

| <u>No. of<br/>Copies</u> | <u>Organization</u>   | <u>No. of<br/>Copies</u> | <u>Organization</u>  |
|--------------------------|---|--------------------------|--|
| 4                        | Director<br>National Aeronautics and<br>Space Administration<br>ATTN: E. Price<br>J. South<br>J. R. Sterrett<br>Tech Library<br>Langley Research Center<br>Langley Station<br>Hampton, VA 23365 | 3                        | Aerospace Corporation<br>ATTN: T. D. Taylor<br>H. Mirels<br>R. L. Varwig<br>Aerophysics Lab.<br>P.O. Box 92957<br>Los Angeles, CA 90009                      |
| 1                        | Director<br>National Aeronautics and<br>Space Administration<br>Lewis Research Center<br>ATTN: MS 60-3, Tech Lib<br>21000 Brookpark Road<br>Cleveland, OH 44135                                 | 1                        | AVCO Systems Division<br>ATTN: B. Reeves<br>201 Lowell Street<br>Wilmington, MA 01887  |
| 2                        | Director<br>National Aeronautics and<br>Space Administration<br>Marshall Space Flight Center<br>ATTN: A. R. Felix, Chief<br>S&E-AERO-AE<br>Dr. W. W. Fowlis<br>Huntsville, AL 35812             | 3                        | The Boeing Company<br>Commercial Airplane Group<br>ATTN: W. A. Bissell, Jr.<br>M. S. 1W-82, Org 6-8340<br>P. E. Rubbert<br>J. D. McLean<br>Seattle, WA 98124 |
| 2                        | Director<br>Jet Propulsion Laboratory<br>ATTN: L. M. Mack<br>Tech Library<br>4800 Oak Grove Drive<br>Pasadena, CA 91103   | 3                        | Calspan Corporation<br>ATTN: A. Ritter<br>G. Homicz<br>W. Rae<br>P.O. Box 235<br>Buffalo, NY 14221   |
| 3                        | Arnold Research Org., Inc.<br>ATTN: J. D. Whitfield<br>R. K. Matthews<br>J. C. Adams<br>Arnold AFB, TN 37389  | 1                        | Center for Interdisciplinary<br>Programs<br>ATTN: Victor Zakkay<br>W. 177th Street & Harlem River<br>Bronx, NY 10453   |
|                          |   | 1                        | General Dynamics<br>ATTN: Research Lib 2246<br>P.O. Box 748<br>Fort Worth, TX 76101  |

DISTRIBUTION LIST

| <u>No. of<br/>Copies</u> | <u>Organization</u>  | <u>No. of<br/>Copies</u> | <u>Organization</u>   |
|--------------------------|--|--------------------------|---|
| 1                        | General Electric Company, RESD<br>ATTN: R. A. Larmour<br>3198 Chestnut Street<br>Philadelphia, PA 19101  | 2                        | Sandia Laboratories<br>ATTN: F. G. Blottner<br>Tech Lib<br>Albuquerque, NM 87115  |
| 2                        | Grumman Aerospace Corporation<br>ATTN: R. E. Melnik<br>L. G. Kaufman<br>Bethpage, NY 11714   | 2                        | United Aircraft Corporation<br>Research Laboratories<br>ATTN: M. J. Werle<br>Library<br>East Hartford, CT 06108   |
| 2                        | Lockheed-Georgia Company<br>ATTN: B. H. Little, Jr.<br>G. A. Pounds<br>Dept. 72074, Zone 403<br>86 South Cobb Drive<br>Marietta, GA 30062        | 1                        | Vought Systems Division<br>LTV Aerospace Corporation<br>ATTN: J. M. Cooksey<br>Chief, Gas Dynamics<br>Lab, 2-53700<br>P.O. Box 5907<br>Dallas, TX 75222 |
| 1                        | Lockheed Missiles and Space<br>Company<br>ATTN: Tech Info Center<br>3251 Hanover Street<br>Palo Alto, CA 94304                                   | 1                        | Arizona State University<br>Department of Mechanical and<br>Energy Systems Engineering<br>ATTN: G. P. Neitzel<br>Tempe, AZ 85281                        |
| 4                        | Martin-Marietta Laboratories<br>ATTN: S. H. Maslen<br>S. C. Traugott<br>K. C. Wang<br>H. Obremski<br>1450 S. Rolling Road<br>Baltimore, MD 21227 | 3                        | California Institute of<br>Technology<br>ATTN: Tech Library<br>H. B. Keller<br>Mathematics Dept.<br>D. Coles<br>Aeronautics Dept.<br>Pasadena, CA 91109 |
| 2                        | McDonnell Douglas Astronautics<br>Corporation<br>ATTN: J. Xerikos<br>H. Tang<br>5301 Bolsa Avenue<br>Huntington Beach, CA 92647                  | 1                        | Cornell University<br>Graduate School of Aero Engr<br>ATTN: Library<br>Ithaca, NY 14850   |
| 1                        | McDonnell-Douglas Corporation<br>Douglas Aircraft Company<br>ATTN: T. Cebeci<br>3855 Lakewood Boulevard<br>Long Beach, CA 90801                  | 2                        | Illinois Institute of Tech<br>ATTN: M. V. Morkovin<br>H. M. Nagib<br>3300 South Federal<br>Chicago, IL 60616  |



DISTRIBUTION LIST

| <u>No. of</u><br><u>Copies</u> | <u>Organization</u>  | <u>No. of</u><br><u>Copies</u> | <u>Organization</u>   |
|--------------------------------|--|--------------------------------|---|
| 1                              | The Johns Hopkins University<br>ATTN: S. Corrsin<br>Dept of Mechanics and<br>Materials Science<br>Baltimore, MD 21218  | 1                              | Purdue University<br>Thermal Science & Prop Center<br>ATTN: Tech Library<br>W. Lafayette, IN 47907  |
| 3                              | Massachusetts Inst of Tech<br>ATTN: E. Covert<br>H. Greenspan<br>Tech Lib<br>77 Massachusetts Avenue<br>Cambridge, MA 02139                                    | 1                              | Rensselaer Polytechnic<br>Institute<br>Department of Math. Sciences<br>ATTN: R. C. DiPrima<br>Troy, NY 12181                              |
| 2                              | North Carolina State Univ<br>Mechanical and Aerospace<br>Engineering Department<br>ATTN: F. F. DeJarnette<br>J. C. Williams<br>Raleigh, NC 27607               | 1                              | Rutgers University<br>Department of Mechanical,<br>Industrial and Aerospace<br>Engineering<br>ATTN: R. H. Page<br>New Brunswick, NJ 08903 |
| 1                              | Notre Dame University<br>ATTN: T. J. Mueller<br>Dept of Aero Engr<br>South Bend, IN 46556  | 1                              | Southern Methodist University<br>Department of Civil and<br>Mechanical Engineering<br>ATTN: R. L. Simpson<br>Dallas, TX 75275             |
| 2                              | Ohio State University<br>Dept of Aeronautical and<br>Astronautical Engineering<br>ATTN: S. L. Petrie<br>O. R. Burggraf<br>Columbus, OH 43210                   | 1                              | Southwest Research Institute<br>Applied Mechanics Reviews<br>8500 Culebra Road<br>San Antonio, TX 78228                                   |
| 2                              | Polytechnic Institute of<br>New York<br>ATTN: G. Moretti<br>S. G. Rubin<br>Route 110<br>Farmingdale, NY 11735  | 1                              | University of California-<br>Berkeley<br>Department of Aerospace<br>Engineering<br>ATTN: M. Holt<br>Berkeley, CA 94720                    |
| 3                              | Princeton University<br>James Forrestal Research Ctr<br>Gas Dynamics Laboratory<br>ATTN: S. M. Bogdonoff<br>S. I. Cheng<br>Tech Library<br>Princeton, NJ 08540 | 1                              | University of California-<br>Davis<br>ATTN: H. A. Dwyer<br>Davis, CA 95616  |

DISTRIBUTION LIST

| <u>No. of<br/>Copies</u> | <u>Organization</u>   | <u>No. of<br/>Copies</u> | <u>Organization</u>   |
|--------------------------|---|--------------------------|---|
| 2                        | University of California-<br>San Diego<br>Department of Aerospace<br>Engineering and Mechanical<br>Engineering Sciences<br>ATTN: P. Libby<br>Tech Library<br>La Jolla, CA 92037 | 3                        | University of Southern<br>California<br>Department of Aerospace<br>Engineering<br>ATTN: T. Maxworthy<br>P. Weidman<br>L. G. Redekopp<br>Los Angeles, CA 90007 |
| 1                        | University of Cincinnati<br>Department of Aerospace<br>Engineering<br>ATTN: R. T. Davis<br>Cincinnati, OH 45221   | 1                        | University of Texas<br>Department of Aerospace<br>Engineering<br>ATTN: J. C. Westkaemper<br>Austin, TX 78712  |
| 1                        | University of Colorado<br>Department of Astro-Geophysics<br>ATTN: E. R. Benton<br>Boulder, CO 80302   | 1                        | University of Virginia<br>Department of Aerospace<br>Engineering and Engineering<br>Physics<br>ATTN: I. D. Jacobson<br>Charlottesville, VA 22904              |
| 1                        | University of Hawaii<br>Department of Ocean Engineering<br>ATTN: G. Venezian<br>Honolulu, HI 96822  | 1                        | University of Washington<br>Department of Mechanical<br>Engineering<br>ATTN: Tech Library<br>Seattle, WA 98195  |
| 2                        | University of Maryland<br>ATTN: W. Melnik<br>J. D. Anderson<br>College Park, MD 20740   | 1                        | University of Wyoming<br>ATTN: D. L. Boyer<br>University Station<br>Laramie, WY 82071   |
| 2                        | University of Michigan<br>Department of Aeronautical<br>Engineering<br>ATTN: W. W. Wilmarth<br>Tech Library<br>East Engineering Building<br>Ann Arbor, MI 48104                 | 1                        | Virginia Polytechnic Institute<br>and State University<br>Department of Aerospace<br>Engineering<br>ATTN: G. R. Inger<br>Blacksburg, VA 24061                 |
| 1                        | University of Santa Clara<br>Department of Physics<br>ATTN: R. Greeley<br>Santa Clara, CA 95053   | 1                        | Woods Hole Oceanographic Institute<br>ATTN: J. A. Whitehead<br>Woods Hold, MA 02543   |

DISTRIBUTION LIST

Aberdeen Proving Ground

Dir, USAMSAA

ATTN: DRXSY-D  
DRXSY-MP, H. Cohen

Cdr, USATECOM

ATTN: DRSTE-TO-F

Cdr/Dir, USA CSL

ATTN: Munitions Div, Bldg. E3330  
E. A. Jeffers  
W. C. Dee  
W. J. Pribyl

Dir, Wpns Sys Concepts Team

Bldg. E3516, EA  
ATTN: DRDAR-ACW  
M. Miller  
A. Flatau

USER EVALUATION OF REPORT

Please take a few minutes to answer the questions below; tear out this sheet and return it to Director, US Army Ballistic Research Laboratory, ARRADCOM, ATTN: DRDAR-TSB, Aberdeen Proving Ground, Maryland 21005. Your comments will provide us with information for improving future reports.

1. BRL Report Number \_\_\_\_\_

2. Does this report satisfy a need? (Comment on purpose, related project, or other area of interest for which report will be used.)

\_\_\_\_\_  
\_\_\_\_\_  
\_\_\_\_\_

3. How, specifically, is the report being used? (Information source, design data or procedure, management procedure, source of ideas, etc.) \_\_\_\_\_

\_\_\_\_\_  
\_\_\_\_\_

4. Has the information in this report led to any quantitative savings as far as man-hours/contract dollars saved, operating costs avoided, efficiencies achieved, etc.? If so, please elaborate.

\_\_\_\_\_  
\_\_\_\_\_

5. General Comments (Indicate what you think should be changed to make this report and future reports of this type more responsive to your needs, more usable, improve readability, etc.) \_\_\_\_\_

\_\_\_\_\_  
\_\_\_\_\_  
\_\_\_\_\_

6. If you would like to be contacted by the personnel who prepared this report to raise specific questions or discuss the topic, please fill in the following information.

Name: \_\_\_\_\_

Telephone Number: \_\_\_\_\_

Organization Address: \_\_\_\_\_

\_\_\_\_\_  
\_\_\_\_\_