

AD-A083 202

TELEDYNE CONTINENTAL MOTORS MOBILE AL AIRCRAFT PRODU--ETC F/6 21/7  
MINI-RPV ENGINE DEMONSTRATOR PROGRAM. (U)

MAR 80 B J REZY

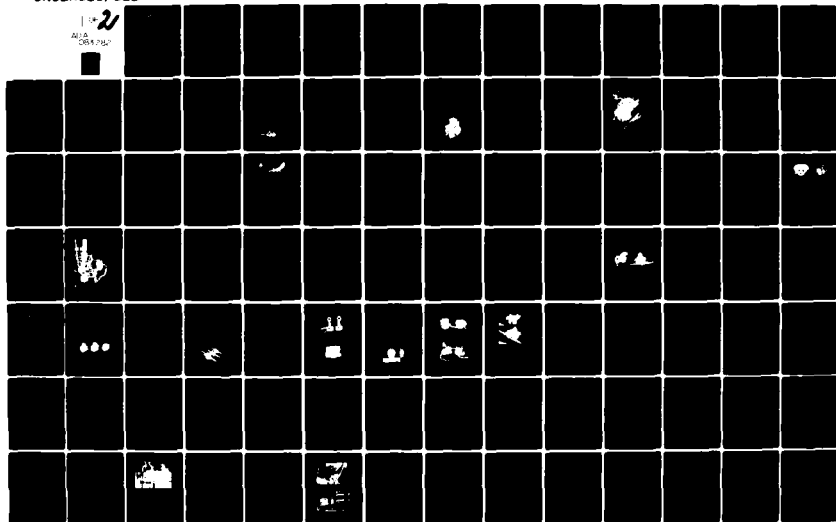
DAAJ02-77-C-0015

UNCLASSIFIED

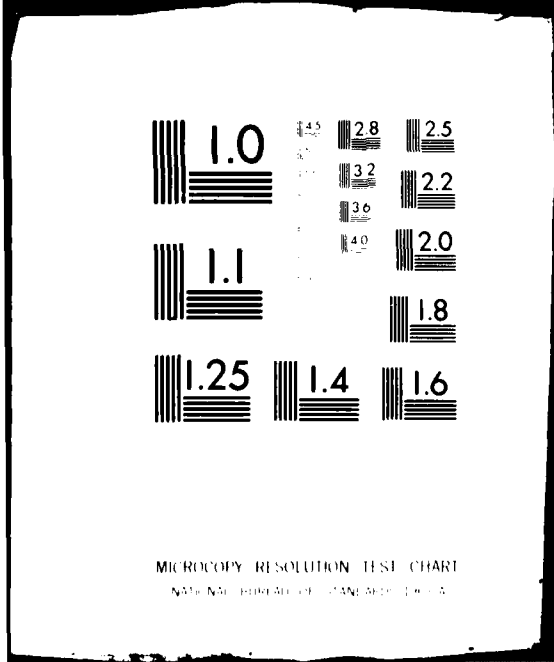
USARTL-TR-79-23

NL

2  
ALIA  
084710



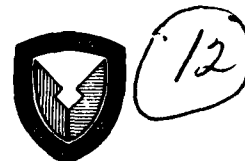
083 28



MICROCOPY RESOLUTION TEST CHART  
NATIONAL BUREAU OF STANDARDS-1963-A

USARTL-TR-79-23

**LEVEL**



**MINI-RPV ENGINE DEMONSTRATOR PROGRAM**

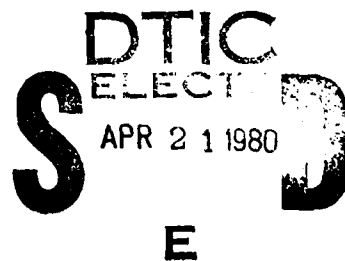
**ADA 083282**

**Bernard J. Rezy  
TELEDYNE CONTINENTAL MOTORS  
Aircraft Products Division  
P. O. Box 90  
Mobile, Ala. 36601**

**March 1980**

**Final Report for Period February 1977 - March 1979**

**Approved for public release;  
distribution unlimited.**



**Prepared for  
APPLIED TECHNOLOGY LABORATORY  
U. S. ARMY RESEARCH AND TECHNOLOGY LABORATORIES (AVRADCOM)  
Eustis, Va. 23604**

**IDG FILE COPY**

**80 4 21 017**

APPLIED TECHNOLOGY LABORATORY POSITION STATEMENT

The reported R&D effort is one of two advanced development programs for 20 hp engines to experimentally demonstrate technology for engines for mini-RPV's through the integration of high rate production components into a two-cylinder opposed two-stroke engine. The 20-hp mini-RPV demonstrator was considered to be successful in that it met the objectives of horsepower, weight per horsepower, life, low vibration and low cost. It is expected that the data from this program will be used in the upcoming Mini-RPV Full-Scale Engineering Development Program. Appropriate technical personnel of this Laboratory have reviewed this report and concur with the conclusions and recommendations contained herein.

Mr. Edward T. Johnson of Propulsion Technical Area, Aeronautical Technology Division and Mr. Kent F. Smith of Reliability, Maintainability and Mission Technology Technical Area, Aeronautical Systems Division, served as Project Engineers for this effort.

DISCLAIMERS

The findings in this report are not to be construed as an official Department of the Army position unless so designated by other authorized documents.

When Government drawings, specifications, or other data are used for any purpose other than in connection with a definitely related Government procurement operation, the United States Government thereby incurs no responsibility nor any obligation whatsoever; and the fact that the Government may have formulated, furnished, or in any way supplied the said drawings, specifications, or other data is not to be regarded by implication or otherwise as in any manner licensing the holder or any other person or corporation, or conveying any rights or permission, to manufacture, use, or sell any patented invention that may in any way be related thereto.

Trade names cited in this report do not constitute an official endorsement or approval of the use of such commercial hardware or software.

DISPOSITION INSTRUCTIONS

Destroy this report when no longer needed. Do not return it to the originator.

UNCLASSIFIED

SECURITY CLASSIFICATION OF THIS PAGE (When Data Entered)

REPORT DOCUMENTATION PAGE		READ INSTRUCTIONS BEFORE COMPLETING FORM	
1. REPORT NUMBER USARTL TR-79-23	2. GOVT ACCESSION NO. ADA083282	3. RECIPIENT'S CATALOG NUMBER	
4. TITLE (and Subtitle) MINI-RPV ENGINE DEMONSTRATOR PROGRAM		5. TYPE OF REPORT & PERIOD COVERED FINAL REPORT February 1977 - March 1978	
7. AUTHOR(s) Bernard J. Rezy		8. CONTRACT OR GRANT NUMBER(s) DAAJ02-77-C-0015	
9. PERFORMING ORGANIZATION NAME AND ADDRESS TELEDYNE CONTINENTAL MOTORS AIRCRAFT PRODUCTS DIVISION P.O. BOX 90, MOBILE, ALABAMA 36601		10. PROGRAM ELEMENT, PROJECT, TASK AREA & WORK UNIT NUMBERS 62732A 1L762732AF34 01 002 EK	
11. CONTROLLING OFFICE NAME AND ADDRESS APPLIED TECHNOLOGY LABORATORY U.S. ARMY RESEARCH & TECHNOLOGY LABORATORIES FORT EUSTIS, VIRGINIA 23604 (AVRADCOM)		12. REPORT DATE Mar 1980	
14. MONITORING AGENCY NAME & ADDRESS (if different from Controlling Office)		13. NUMBER OF PAGES 102	
		15. SECURITY CLASS. (of this report) UNCLASSIFIED	
		15a. DECLASSIFICATION/DOWNGRADING SCHEDULE	
16. DISTRIBUTION STATEMENT (of this Report)  Approved for public release; distribution unlimited.			
17. DISTRIBUTION STATEMENT (of the abstract entered in Block 20, if different from Report)			
18. SUPPLEMENTARY NOTES			
19. KEY WORDS (Continue on reverse side if necessary and identify by block number)  MINI-RPV                      REMOTELY PILOTED RPV                              TWO-STROKE ENGINE                         PROPULSION			
20. ABSTRACT (Continue on reverse side if necessary and identify by block number)  This report details the findings from a 25-month program under Army Contract DAAJ02-77-C-0015 to investigate a MINI-RPV propulsion system and to design, fabricate, test, and deliver a multicylinder, two-stroke technology demonstrative engine for Government evaluation. The work includes the development of three generations of engines: a basic feasibility engine, an engine incorporating a combined alternator-ignition system, and			

DD FORM 1 JAN 73 1473

EDITION OF 1 NOV 65 IS OBSOLETE

UNCLASSIFIED

SECURITY CLASSIFICATION OF THIS PAGE (When Data Entered)

343 426

UNCLASSIFIED

SECURITY CLASSIFICATION OF THIS PAGE(When Data Entered)

20. ABSTRACT (continued)

→ an engine incorporating an exhaust system and design improvements based on development testing of the previous engines. ←

Accession For	
NTIS GRA&I	<input checked="" type="checkbox"/>
DOC TAB	<input type="checkbox"/>
Unannounced	<input type="checkbox"/>
Justification	
By _____	
Distribution / _____	
Subject Codes	
Dist	Standard/or special
A	

UNCLASSIFIED

SECURITY CLASSIFICATION OF THIS PAGE(When Data Entered)

TABLE OF CONTENTS

	<u>PAGE</u>
List of Illustrations . . . . .	4
List of Tables. . . . .	5
Introduction. . . . .	6
First-Generation Engine Design. . . . .	7
Selection of Engine Configuration. . . . .	7
Selection of Off-the-Shelf Components. . . . .	8
Cylinder . . . . .	10
Piston . . . . .	12
Connecting Rod . . . . .	12
Carburetor . . . . .	12
Spark Plug . . . . .	14
Ignition System. . . . .	14
Propeller. . . . .	14
Design of Special Engine Parts . . . . .	15
Crankshaft . . . . .	15
Crankcase. . . . .	16
Induction System . . . . .	19
Exhaust System . . . . .	20
Engine Assembly. . . . .	20
First-Generation Engine Testing . . . . .	24
Dynamometer Stand Testing. . . . .	24
Propeller Stand Testing. . . . .	27
Endurance Stand Testing. . . . .	27
Propeller and Attachment Problems. . . . .	31
Piston-Cylinder Seizure. . . . .	32
Crankpin Bearing Cage Failures . . . . .	33
Second-Generation Engine Design . . . . .	34
Alternator-Ignition System . . . . .	34
Crankshaft . . . . .	38
Crankcase. . . . .	38
Engine Assembly. . . . .	38
Second-Generation Engine Testing. . . . .	41
Propeller Stand Testing. . . . .	41
Dynamometer Stand Testing. . . . .	41
Endurance Stand Testing. . . . .	48
Third-Generation Engine Design. . . . .	52
Exhaust System . . . . .	52
Induction System . . . . .	52
Crankcase. . . . .	54
Crankshaft . . . . .	56
Connecting Rod and Bearings. . . . .	56
Alternator-Ignition System . . . . .	59
Lubricant. . . . .	59
Engine Assembly. . . . .	59
Third-Generation Engine Testing . . . . .	64
Dynamometer Stand Testing. . . . .	64
Propeller Stand Testing. . . . .	67
Exhaust Noise Testing. . . . .	67
Endurance Stand Testing. . . . .	69

	<u>PAGE</u>
Conclusions . . . . .	72
Recommendations . . . . .	73
Appendix A - Induction System Types . . . . .	74
Appendix B - Exhaust System Considerations. . . . .	77
Appendix C - TCM Test Facility. . . . .	82
Appendix D - Engine Weight Breakdown. . . . .	90
Appendix E - Second-Generation Engine Buildup Procedure and Stocklist. . . . .	91
Appendix F - Third-Generation Engine Buildup Procedure and Stocklist. . . . .	96

LIST OF ILLUSTRATIONS

<u>FIGURE</u>		<u>PAGE</u>
1	Opposed Twin Concept . . . . .	9
2	Exploded View of Tillotson Carburetor. . . . .	13
3	MK II First Generation Crankshaft. . . . .	15
4	Crankshaft Balance Diagram . . . . .	17
5	MK II First-Generation Crankcase . . . . .	18
6	Piston Ported Induction System . . . . .	19
7	Reed Cage Induction System . . . . .	20
8	First-Generation MK II Engine. . . . .	21
9	First-Generation MK II Outline Drawing . . . . .	22
10	First-Generation MK II Exploded View . . . . .	23
11	Full Throttle Performance Curves for Piston Port and Reed Valve Induction Systems at Equal Peak Power . . . . .	25
12	Full Throttle Performance Curve First- Generation Engine . . . . .	28
13	MK II Engine Mounting Plate. . . . .	29
14	Alternator with Integrated PCU . . . . .	36
15	Rotor Construction and Flux Path . . . . .	37
16	Alternator Schematic Diagram . . . . .	37
17	Alternator Design. . . . .	38
18	MK II Crankshaft Design Changes. . . . .	39
19	MK II Crankcase Bearing Support Changes. . . . .	39
20	Second-Generation MK II Engine . . . . .	40
21	Phelon Alternator Output . . . . .	42
22	Second-Generation Engine Full Throttle Curve . . . . .	43
23	Second-Generation Engine Prop Load Curve . . . . .	45
24	Second-Generation Engine Full Throttle Curve . . . . .	46
25	Second-Generation Engine Prop Load Curve . . . . .	47
26	MK II Reed Cage Induction Configuration. . . . .	49
27	MK II Muffler. . . . .	53



<u>FIGURE</u>		<u>PAGE</u>
28	Third-Generation Piston Ported Induction System. . . . .	53
29	First-Second-Third-Generation Crankcases . . . . .	54
30	MK II Crankcase Bearing Support Changes. . . . .	55
31	First-Second-Third-Generation Crankshafts. . . . .	56
32	MK II Crankshaft Design Changes. . . . .	57
33	Connecting Rod Design Changes. . . . .	58
34	Wrist Pin Design Changes . . . . .	58
35	Crankpin Bearing Comparison. . . . .	59
36	First and Second-Generation Alternator Designs . . . . .	60
37	Third-Generation MK II Engine Specifications . . . . .	61
38	Third-Generation MK II Outline Drawing . . . . .	62
39	Third-Generation MK II Engine Details. . . . .	63
40	Third-Generation Engine Full Throttle Curve. . . . .	65
41	Third-Generation Engine Prop Load Curve. . . . .	66
42	Noise Measurement Locations. . . . .	68
C-1	Floor Plan of the Mini-RPV Area Located in Building No. 26 . . . . .	82
C-2	TCM Mini-RPV Dynamometer Test Cell . . . . .	83
C-3	TCM Mini-RPV Propeller Test Cell and Control Room . . . . .	86

LIST OF TABLES

<u>TABLE</u>		<u>PAGE</u>
1	Vendor Investigation - Engines . . . . .	10
2	Some RPV Candidates. . . . .	11
3	Propellers Selected. . . . .	15
4	Measured Noise Data. . . . .	70
5	Corrected Noise Data . . . . .	71

## INTRODUCTION

Interest in small remotely piloted vehicles (MINI-RPV's) has increased considerably in the past few years. The U.S. Army, recognizing the need to establish a dependable, qualified RPV engine development and manufacturing source, initiated a MINI-RPV engine demonstration program in 1976. Teledyne Continental Motors (TCM) responded to the U.S. Army's request and received one of the two awards to design, fabricate, test and deliver a multicylinder, two-stroke technology demonstration engine for Government evaluation.

Specific goals of the program are summarized as follows:

Gross shaft output	-	20 horsepower
Engine speed	-	7000 to 8000 rpm
Specific fuel consumption at wide open throttle	-	0.80 lbs/bhp hr.
Altitude capability	-	12,000 ft.
Weight	-	24 lbs.
Design life	-	150 hours

Also, since only limited production is anticipated for the present application, it was considered very desirable to base the demonstration engine development on the use of off-the-shelf production parts and components as far as possible and use simple tooling for any special parts required.

## FIRST-GENERATION ENGINE DESIGN

The TCM MK II engine has evolved from the U.S. Army program goals with a concerted effort to take best advantage of the unique possibilities that the two-stroke cycle offers for this engine application. This section describes in detail the design philosophy and components used on the basic feasibility engine, the TCM MK II first-generation engine. Changes from the basic design for the second and third-generation engines are covered in separate sections later in this report.

### SELECTION OF ENGINE CONFIGURATION

One of the major considerations in designing the MK II engine was the number and arrangements of the cylinders. Even though a single cylinder design might provide the minimum basic engine weight possible for the desired output, several disadvantages make this engine configuration undesirable for this application:

- (1) High vibration levels would be transmitted into the airframe even with a sophisticated vibration isolation system.
- (2) Large bore cylinders are difficult to cool and produce less bhp/in.<sup>3</sup> Longer stroke cylinders produce higher inertia loads and piston speeds at the same RPM levels.
- (3) A 150-hour life would be difficult to achieve due to the high thermal loading, cooling problems, and high mechanical stress levels.

A twin cylinder engine of either the parallel (in-line) or opposed twin variety would be more acceptable for this application because of better balancing and easier control of thermal loading problems. However, a two-cylinder in-line engine would still be unattractive for this application for the following reasons:

- (1) Cooling problems with in-line cylinders.
- (2) Excessive weight for the crankshaft caused by the necessary spacing for the cylinders.
- (3) Poor primary pitch mode and secondary vertical mode balancing of reciprocating parts, leading to unacceptably high vibration levels being fed into the airframe structure.
- (4) Greater engine assembly length, leading to airframe installation and center of gravity problems.

An opposed twin cylinder engine could be considered a very good candidate for this application but still has the following disadvantages intrinsically incorporated in its design:

- (1) The torque pulsations, which would be of a similar magnitude to those from a single, would produce high vibration levels unless suitably attenuated by an effective vibration isolation system.
- (2) These same torque pulsations could result in a relatively high idle speed of an erratic nature.

The torque pulsations emanating from a four-cylinder, horizontally opposed engine would be of considerably lesser magnitude than those from a twin-cylinder engine. With a four-cylinder engine, however, other problems are intrinsically incorporated into the design, including:

- (1) Cooling difficulties with the two rear cylinders which are shrouded from the airstream.
- (2) Excessive weight due in part to the additional crankshaft length.
- (3) Airframe installation problems due to the greater engine length.

A four-cylinder radial arrangement would be very advantageous from the standpoint of smooth torque, low vibration, good cooling and structural efficiency leading to light weight. Crankcase scavenging would involve some complications in separating the crankcases for the four cylinders. TCM does not believe that four cylinders are required to meet the specified power ratings or that this radial configuration would be justified for this application unless its very low vibration characteristics would be a decisive advantage.

With due considerations to the above configurations, TCM has pursued the development of a horizontally opposed twin-cylinder engine configuration. Figure 1 illustrates this engine arrangement.

#### SELECTION OF OFF-THE-SHELF COMPONENTS

The companies listed in Table 1 were contacted with respect to possible off-the-shelf engines and/or components that might be adapted to the engine goals. Engines for RPV, Go-Kart, Chain Saw, Snowmobile, Light Aircraft, Outboard and Motorcycle applications were investigated. Table 2 lists specifications of the engines that were evaluated.

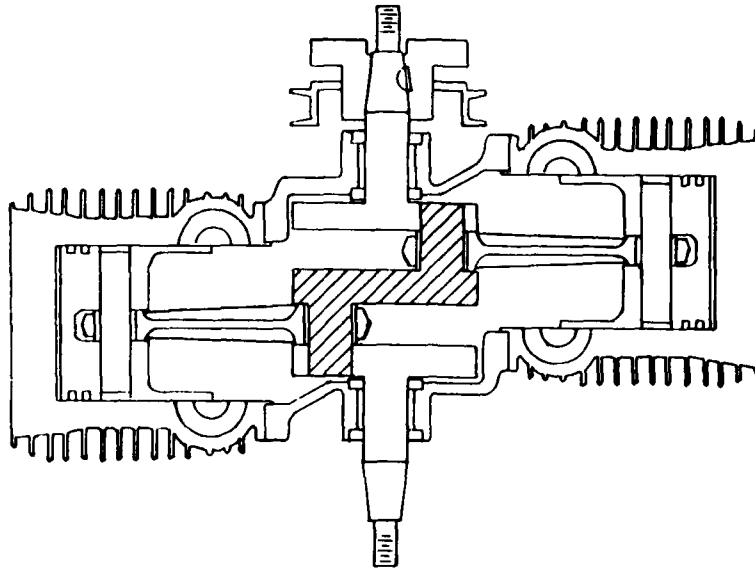


FIGURE 1. OPPOSED TWIN CONCEPT.

The current RPV engines that were investigated would require a considerable up-rating and some required special fuels that were considered undesirable. Go-Kart engines that might otherwise be applicable, had cylinders combined with crankcases, which precluded the desired two-cylinder opposed configuration. Snowmobile and Light Aircraft engine cylinders were too large and Outboard and Motorcycle cylinders were too heavy.

Chain Saw engine production remained as the sole possible source of inexpensive, proven parts that could be adapted to this RPV engine requirement. Selection narrowed to a piston displacement range from 7.5 to 9 cu. in. (125-150 cc) and the otherwise attractive McCullough MC-101 chain saw cylinder was eliminated because of the combined cylinder crankcase design.

The well developed high production Stihl 090 chain saw cylinder with piston and connecting rod assembly remained as an attractive possibility for the application.

It was recognized that incorporating a standard production cylinder into the RPV engine design would benefit the program (particularly with respect to development cost and time and the early availability of effective engines for flight vehicles) much more than any other single component. Probably such benefit would exceed the total that could be derived from all other production engine parts that might be utilized.

TABLE 1. VENDOR INVESTIGATION - ENGINES.

Acushnet	Kendrick Engineering
Arrow	Kiekhaefer Aero Marine
AVCO Lycoming	Kohler Kolbo
Barker Engines	McCulloch
Besco	Morse
Borzecki	Motion Development Company
Chrysler	Murphy
Conejo	Nelson
Curtiss-Wright	O&R
D.H. Enterprises	Onan
Deko-Grand	Outboard Marine Corporation
Diamond Chain	Parts Unlimited
Dooling Brothers	Plessey
Dorlee	Rosco Belts
Eaton	Rosspower, Incorporated
Electro-Pacific	Rotary Combustion Company
Fox Manufacturing	Sakert
Franklin Engine Company	Stihl
Fuji	Suzuki
Garrett	Tecumseh Products
Goodyear	Teledyne CAE
Harley-Davidson Motor Company	Kolbo Korp
Harry Rice	Teledyne CM
Hercules Distributing Company	Teledyne WM
Hirth	Tillotson
Homelite Corporation	Uniroyal
Honda	Vi-Star
Janowski	Walbo
JLO-Rockwell Engineering Division	Western Gear
Jordan Porche	Wiseco Piston
K&B Manufacturing	Wolf Industries
Kawasaki	Yamaha International

#### CYLINDER

Use of the Stihl cylinder would reduce the compounding of development problems and result in a considerable saving in the expenditure of time and money that would be difficult to justify until actual RPV requirements were more firmly established.

It was anticipated that the modest power uprating that would be required could be accomplished (in spite of the adverse cooling provisions) by some additional expenditure of fuel (at high power levels) for internal fuel cooling. Because of the very low weight of the Stihl 090 cylinder, this might result in a lower weight of engine plus fuel (for the mission duty cycle) than if more effective but heavier motorcycle type cylinder cooling fins were utilized.

TABLE 2. SOME RPV ENGINE CANDIDATES.

ENGINES	NO. OF CYLINDERS	STROKES/CYCLE	DISPLACEMENT IN. <sup>3</sup>	CM <sup>3</sup>	HP	POWER KW	WEIGHT LB	KG	RATED RPM	BSFC	COST 1976 \$	PRESENT APPLICATION	BASIC IGNITION	FUEL
KOLBO D2118	2	2	11.8	193	18	13.4	11	5.0	7500	N/A	\$1,000	RPV	GLO-PLUG	ALC/NIT/OIL
KOLBO D2100	2	2	9.8	160	13	9.7	9.25	4.2	7500	N/A	1,000	RPV	GLO-PLUG	ALC/NIT/OIL
KOLBO D274	2	2	7.4	121	10	7.5	9.0	4.1	7500	N/A	1,000	RPV	GLO-PLUG	ALC/NIT/OIL
McCULLOCH MC-101	1	2	7.5	123	10	7.5	12	5.5	9500	1.0+	125	GO-KART	SPARK	GAS/OIL
HOMELITE 650	1	2	6.0	98	7	5.2	8EST	3.6	N/A	N/A	100	CHAIN SAW	SPARK	GAS/OIL
CHRYSLER 820	1	2	8.2	134	8	6.0	13.5	6.1	7000	N/A	150	GO-KART	SPARK	GAS/OIL
DH ENTERPRISES DVAD274	2	2	16.7	274	16	11.9	12.6	5.7	6500	N/A	1,000	RPV	SPARK	GAS/OIL
JLO ROCKWELL 1230	1	2	13.6	223	15.5	11.6	29	13.2	N/A	N/A	120	SNOWMOBILE	SPARK	GAS/OIL
KOHLER K440-2AS	2	2	21.6	354	42	31.3	64	29.1	7500	N/A	--	SNOWMOBILE	SPARK	GAS/OIL
STIHL 090	1	2	8.36	137	8.5	6.3	12EST	5.5	8000	.9	--	CHAIN SAW	SPARK	GAS/OIL
AVCO-LYCOMING DIV 0-235-C1B	4	4	223	--	115	85.8	213	96.8	2800	N/A	--	LIGHT AIRCRAFT	SPARK	GAS
JLO ROCKWELL LR440/2	2	2	25.2	413	35	26.1	62	28.2	N/A	N/A	225	SNOWMOBILE	SPARK	GAS/OIL
FRANKLIN ENGINE CO., INC. 2A-120	2	4	--	--	60	44.8	133	60.5	N/A	N/A	--	LIGHT AIRCRAFT	SPARK	GAS
TELEDYNE CONTINENTAL MTRS 0-200-A	4	4	201	--	100	74.6	200	90.9	2750	.6	--	LIGHT AIRCRAFT	SPARK	GAS
BARKER ENGINE (VW CONVERSIONS)	4	4	98.1	1607	55	41.0	136	61.8	N/A	N/A	1,255	SPORT AIRCRAFT	SPARK	GAS
BARKER ENGINE (VW CONVERSIONS)	4	4	112.4	1842	70	52.2	136	61.8	N/A	N/A	1,435	SPORT AIRCRAFT	SPARK	GAS
BARKER ENGINE (VW CONVERSIONS)	4	4	120.1	1968	80	59.7	138	62.7	N/A	N/A	1,575	SPORT AIRCRAFT	SPARK	GAS
LON STEVENS CO. MODIFIED MERCURY OUTBOARD ENGINE (LIQUID COOLED)	4	2	44	721	80	59.7	72EST	33EST	N/A	N/A	700	AUTO & BOAT RACING	SPARK	GAS/OIL
WILLIAMS WR24-6 TURBOJET	N/A	JET	--	--	121 LB THRUST	55 KG THRUST	30	13.6	N/A	N/A	--	AIRCRAFT		JET FUEL
ROSS POWER	4	2	7.7	128	15	11.2	8	3.6	N/A	N/A			GLO-PLUG	ALC/NIT/OIL
GARRETT	2	2	15	246	25	18.7	16	7.3	8500	N/A			SPARK	GAS/OIL

The Stihl 090 cylinders are machined from low pressure die castings by Mahle of West Germany and are provided with a porous chrome-plated bore surface. The bore diameter of 2.60 in. (66 mm) combined with a stroke of 1.57 in. (40 mm) results in a per-cylinder displacement of 8.36 cu. in. (137 cc), and together with the accompanying piston and connecting rod established the basic dimensions of the TCM MK II engine.

#### PISTON

The piston for the Stihl 090 chain saw is also produced by Mahle, but in this case from a permanent mold aluminum casting. The piston is a selective fit in the cylinder bore to improve sealing and heat transfer characteristics and is supplied in a matched set with the cylinder.

#### CONNECTING ROD

The 090 connecting rod is produced by Stihl, and TCM's original intention was to use a one-piece version with a single-piece crankpin bearing cage assembled on a pressed-together crankshaft. However, the desire for simpler field replacement led to the incorporation of an alternate Stihl design with a split big end and split crankpin bearing cage. While there were some apprehensions about the required durability (at high speed) of the split bearing cage, it was anticipated that the crankshaft would be lighter and its development somewhat simplified.

#### CARBURETOR

In the interest of availability, low cost, light weight and simplicity of adjustment and control, a single HR-43A Tillotson diaphragm-type production carburetor was incorporated in the initial design. This assembly combines the major die cast aluminum components with the detail parts as shown in Figure 2. This diaphragm carburetor incorporates the normal controls and adjustments of a float-type carburetor, such as choke, throttle, idle and main mixture adjustment screws, idle speed screw and inlet valve needle and seat. Rather than being controlled by float level, however, the fuel pressure upstream of the fuel jet is held constant by the fuel pressure acting on one side of the pump diaphragm in opposition to an inlet control spring which exerts a predetermined force on the inlet control lever holding the needle on its seat. As in a float carburetor, the fuel pressure is maintained slightly below ambient to prevent flooding, and the additional venturi suction establishes the flow rate thru the jet for mixture control. The movement of the pump diaphragm in one direction draws fuel into the fuel chamber, and reverse movement forces fuel out of the fuel chamber past the inlet needle and thru the seat into the metering chamber. Diaphragm movement is caused by pressure pulsations from the engine crankcase acting on one side.



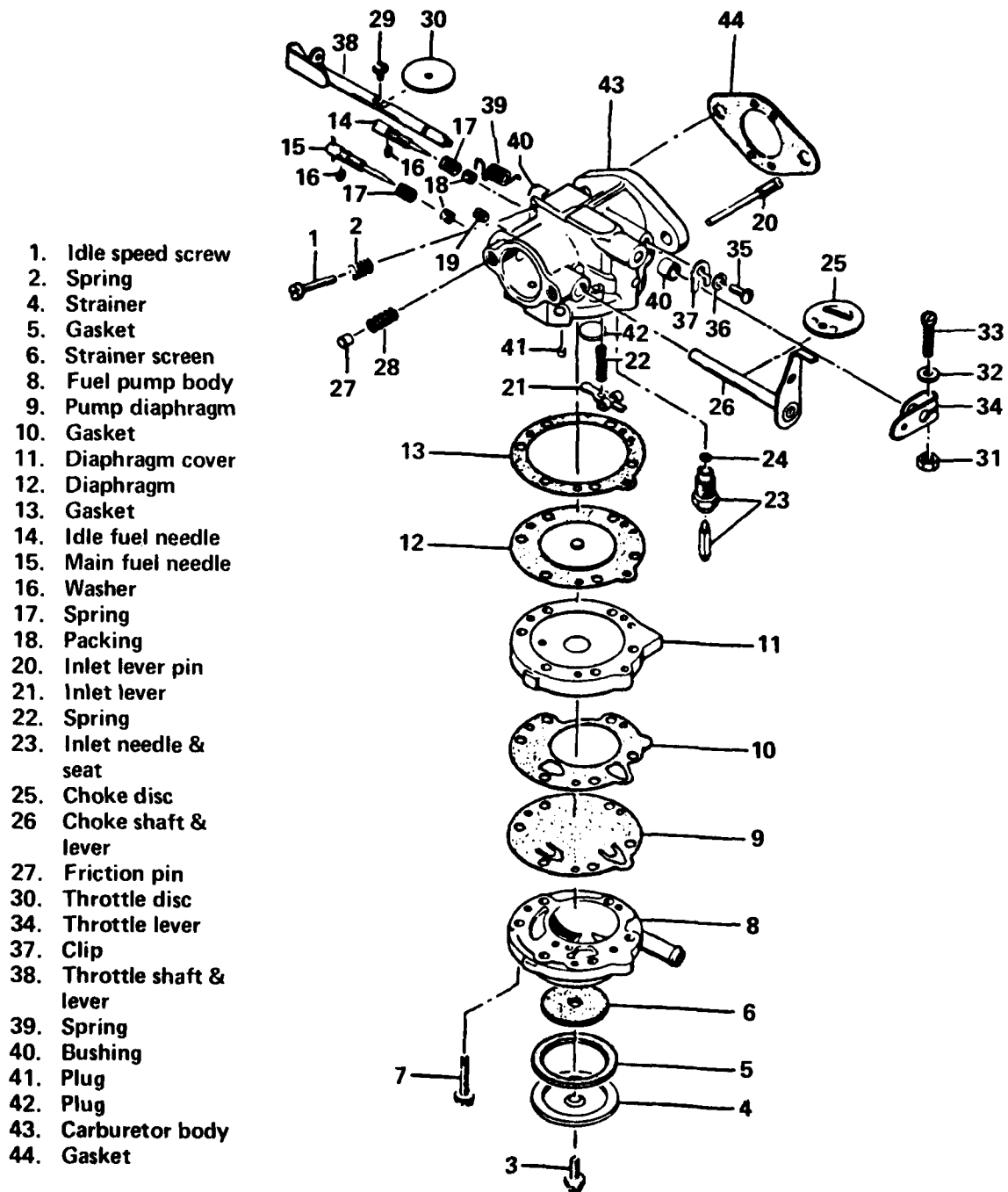


FIGURE 2. EXPLODED VIEW OF TILLOTSON CARBURETOR.

The metering diaphragm is subjected to engine vacuum on the metering chamber side and atmospheric pressure on the vented side. Atmospheric pressure on the vented side pushes the diaphragm toward the inlet control lever, against the lower fuel pressure and the control spring force, thus opening the inlet needle to allow fuel to enter the metering chamber until it restores the prescribed chamber pressure.

The carburetor also incorporates a ball check valve main nozzle. The ball check valve allows fuel to flow into the mixing passage and prevents the reverse flow of air into the metering chamber under inlet spit-back conditions.

A plastic turret-type fuel inlet connection is the cover to the fuel strainer section of the carburetor and can be rotated thru 360° for any required inlet connection location. The strainer consists of a fine mesh screen to insure a clean fuel supply into the carburetor.

#### SPARK PLUG

The readily available Model RMJ-3 Champion spark plug was selected to meet radio frequency shielding requirements and to be slightly colder in heat range than the unshielded CJ-4 Champion spark plug specified for the Stihl Model 090 chain saw engine.

#### IGNITION SYSTEM

The original ignition system was a combination by Phelon of their production low-tension magneto for one chain saw, the CDI control unit with ignition trigger for another chain saw and two high tension ignition coils of a type supplied for a production outboard motor. The high tension coils transform the magneto output of approximately 220 volts to some 20,000 to 30,000 volts across each spark plug. The trigger unit automatically provides a 15-degree spark retard at cranking speeds. The CDI system was selected for its more rapid rate of voltage rise and consequent better immunity to carbon shunt fouling of the spark plug.

#### PROPELLER

Though not a part of the RPV Engine Demonstration Program, the propeller, with respect to its loading of the engine, its attachment and its dynamic characteristics, was an important factor in the engine design.

While the propellers that were used by TCM in this program were custom made with respect to dimensional details, they were similar in design and construction to those produced in limited quantities. Table 3 presents the two-bladed propellers used during the program.

**TABLE 3. PROPELLERS SELECTED.**

<u>Manufacturer</u>	<u>Material</u>	<u>Diameter (Inches)</u>	<u>Pitch (Degrees)</u>
Warnke	Wood	27	Ground adjustable
Kolbo	Wood	28	11
Sensenich	Wood	28	15
McCauley	Fiberglass	28	10

DESIGN OF SPECIAL ENGINE PARTS

CRANKSHAFT

The crankpin journal requirements are established by the Stihl 090 cylinder, piston, connecting rod and crankpin bearing selection. The single-piece crankshaft is machined from a length of AMS 6294 steel bar stock. Surface finishes and manufacturing procedures follow typical outboard motor and chain saw engine crankshaft practice, with main and crankpin bearing journal surfaces being carburized, hardened and ground and other surfaces blanked off during carburization to retain toughness and machinability in this forging type steel. The first-generation MK II crankshaft is shown in Figure 3.

The aft end of the crankshaft was provided with a taper for attachment of the propeller hub and magneto rotor. A keyway was provided for angular location, and a threaded extension for a nut to draw the hub up on the taper. It was intended that all torsion loads should be carried by friction, at the tapered interface, in order to avoid keyway fretting as a result of the anticipated high torque reversals. For design simplicity, an identical extension was incorporated at the forward end of the crankshaft. This provided a much safer starter drive location for cranking the engine in propeller test stand operations. Also a forward drive was available for possible relocation of the ignition rotor or other accessory.



**FIGURE 3. MK II FIRST-GENERATION CRANKSHAFT.**

The inherent balance of this opposed cylinder arrangement is very good with only a primary yawing couple resulting from the offset of the opposing inertia forces produced by the reciprocating masses in the two cylinders. The rotating masses at the two crankpins plus 46% of the yawing couple were balanced by the incorporation of crankshaft counterweighting in the outer crank cheeks. Figure 4 compares the calculated balancing that was achieved to that without counterweighting. Concessions made for second harmonic effects are clearly evident.

Weight and economics do not allow for perfect balance of this engine; the small remaining unbalanced couples involved and engineering experience demonstrate that perfect balance is not required. This crankshaft arrangement permits incorporation of the best balance obtainable within the limits of a simple engine configuration.

#### CRANKCASE

The basic design of the crankcase was prescribed by the structural and dimensional requirements for the following:

- Cylinders and connecting rod
- Crankshaft bearings and seals
- Compactness for effective crankcase pumping
- Mounting of ignition components and other accessories
- Engine to airframe mounting
- Induction system considerations

For loop scavenged two-stroke cycle engines of this type it is conceivable to use any of three different forms of induction systems. Each type of induction system has its own intrinsic advantages and disadvantages and each will effect the design of the crankcase. Appendix A describes in detail the tradeoffs of the rotary valve, reed valve and piston port induction system. Since the first-generation engine crankcase was intended to be a "breadboard" to properly mount the other engine components for coordinated and representative testing during dynamometer development and propeller stand demonstrations, and since the selected cylinder has a piston inlet port, the decision was made to provide an opening in the crankcase that would accept an inlet reed valve assembly. Thus, in experimental development, either a piston ported or reed valve induction system could be investigated with unused openings being blocked off.

The major forces on the crankcase are due to gas pressure trying to separate the opposing cylinders. Relatively smaller loads due to engine torque reactions and accelerated flight conditions must be transmitted by the crankcase structure to the engine mounting points. Primary objective during design was to provide mounting simplicity and adaptability for easy modification.

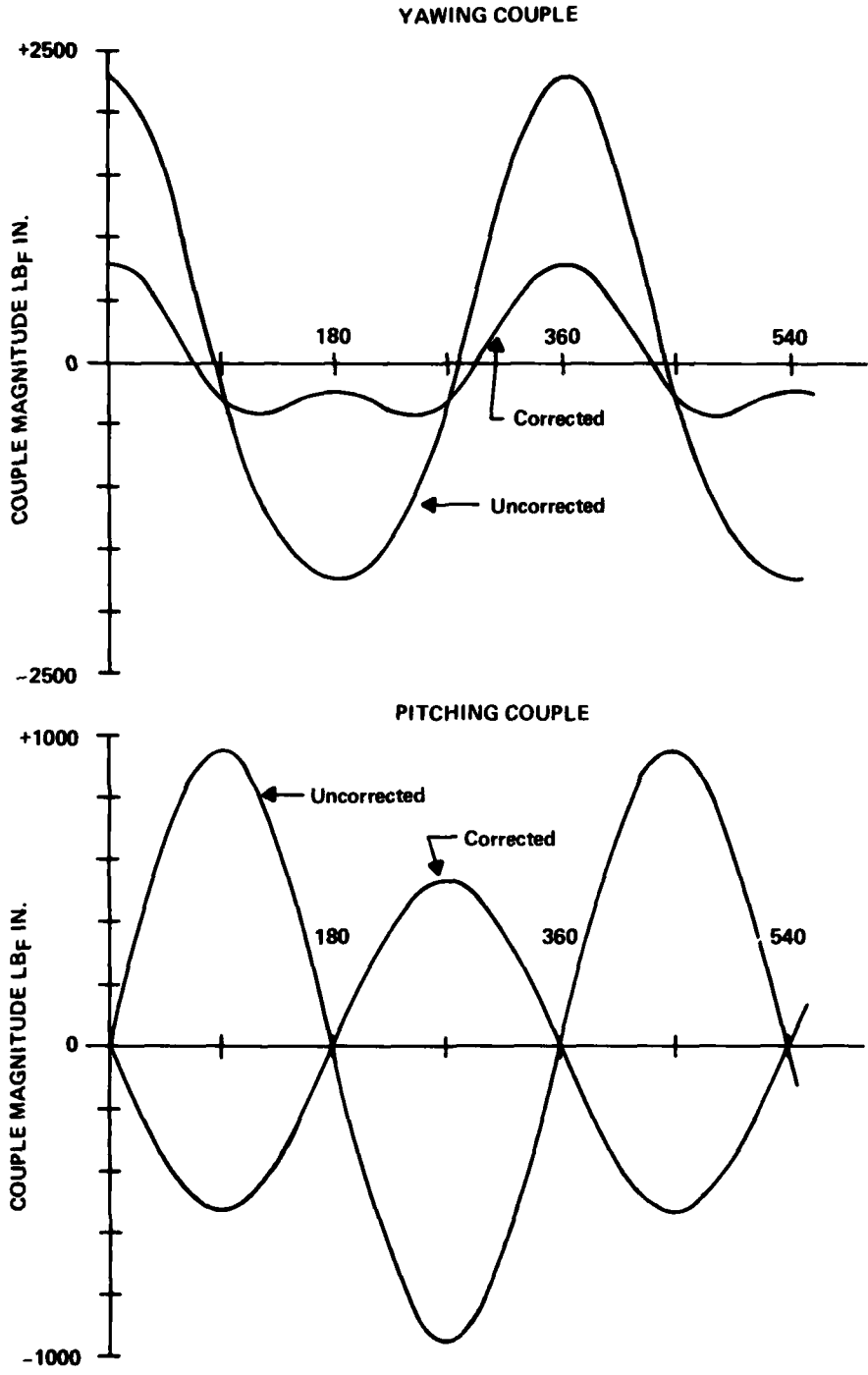


FIGURE 4. CRANKSHAFT BALANCE DIAGRAM.

Substantial structural margins were provided to minimize crankcase problems during testing and a separate engine mount and brackets for ignition components and other accessories were provided for convenience. Integration of components and improvement of crankcase structural efficiency for weight reduction would be the subject of subsequent development and demonstration. Figure 5 depicts the first-generation MK II crankcase assembly.

The crankcase was made in two halves with the central split-line perpendicular to the crankshaft axis. The two halves were machined from identical 356 aluminum alloy sandcastings which were heat treated to the T6 condition. These parts are doweled together by the four body-fit longitudinal bolts to permit line boring for the bearings and facing of the surfaces for the cylinder bases as a matched assembly. Only negligible loads need be carried across the split-line and the inter cylinder tension forces can be carried from one side to the other as direct stresses with a minimum of bending.

The crankcase was made as compact as possible to improve crankcase pumping characteristics; however, consideration was given to restrictions that might impede the inflow of fresh charge (thru either the cylinder inlet ports or the alternate reed valve opening that was provided) or its outflow thru the transfer passages.

Duplicate bosses are provided on both faces of the crankcase. These permit attachment of the engine mounting bracket and support of ignition components, speed transducer and other accessories.

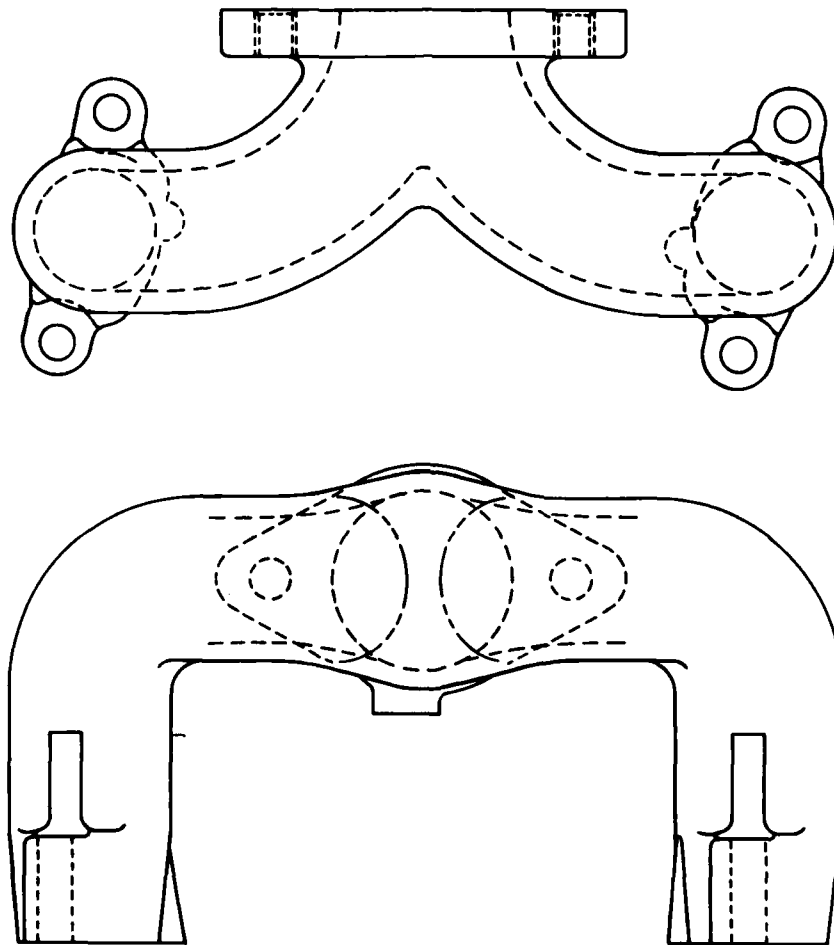


FIGURE 5. MK II FIRST-GENERATION CRANKCASE.

## INDUCTION SYSTEM

Provision of the reed inlet valve opening in the MK II crankcase and the piston controlled inlet ports incorporated in the Stihl 090 cylinders permitted both induction system types to be investigated. Unused openings were plugged to more accurately represent the internal geometry for each system being tested.

From the standpoint of simplicity of application, adjustment and control, and possibly at the sacrifice of some performance, it was considered very advantageous to use a single carburetor. This centrally mounted carburetor branched thru a simple manifold on top of the engine, to the inlet ports on the two cylinders. Figure 6 shows this inlet manifold.



**FIGURE 6. PISTON PORTED INDUCTION SYSTEM.**

In the reed valve arrangement the carburetor fed directly thru a reed cage assembly that is mounted within the inlet neck that was provided on top of the crankcase. Figure 7 shows a section thru the carburetor inlet connection and the reed valve assembly. The valve assembly is comprised of the wedge-shaped reed cage (that forms the reed seat) and two reeds with a stop plate on each side. The flexible steel reeds were 0.010 in. thick, 1/2 in. wide and 1-1/2 in. long and their opening (at the tip) was limited to 0.30 in. by the stop plate which also served to clamp the fixed ends of the reeds against the reed cage seat.

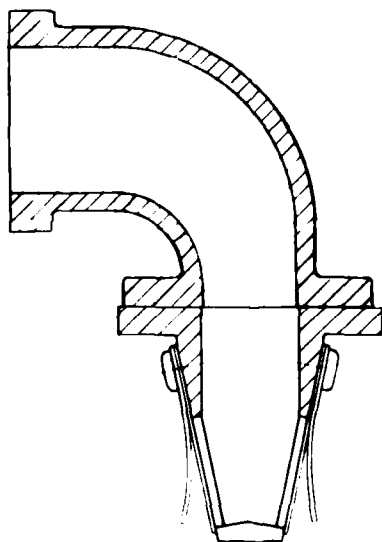
#### EXHAUST SYSTEM

With no exhaust noise requirement for the first-generation engine, individual stacks were used to accommodate the dynamometer or propeller test stand installation.

#### ENGINE ASSEMBLY

Figures 8 and 9 depict the first-generation MK II engine as configured with the reed valve induction system, while Figure 10 illustrates the components and their assembly. As can be seen in Figure 8, the complete ignition system for the first-generation engine was mounted on the propeller end of the crankshaft. The Trigger pickup and high tension coils were direct mounted to the crankcase by a common bracket which located them in suitable proximity to the magneto rotor.

The magneto rotor was bolted direct to the propeller hub for quick assembly and disassembly, and by doing so, provided more inertia to the propeller for additional flywheel effect for smooth operation at idle conditions.



**FIGURE 7. REED CAGE INDUCTION SYSTEM.**



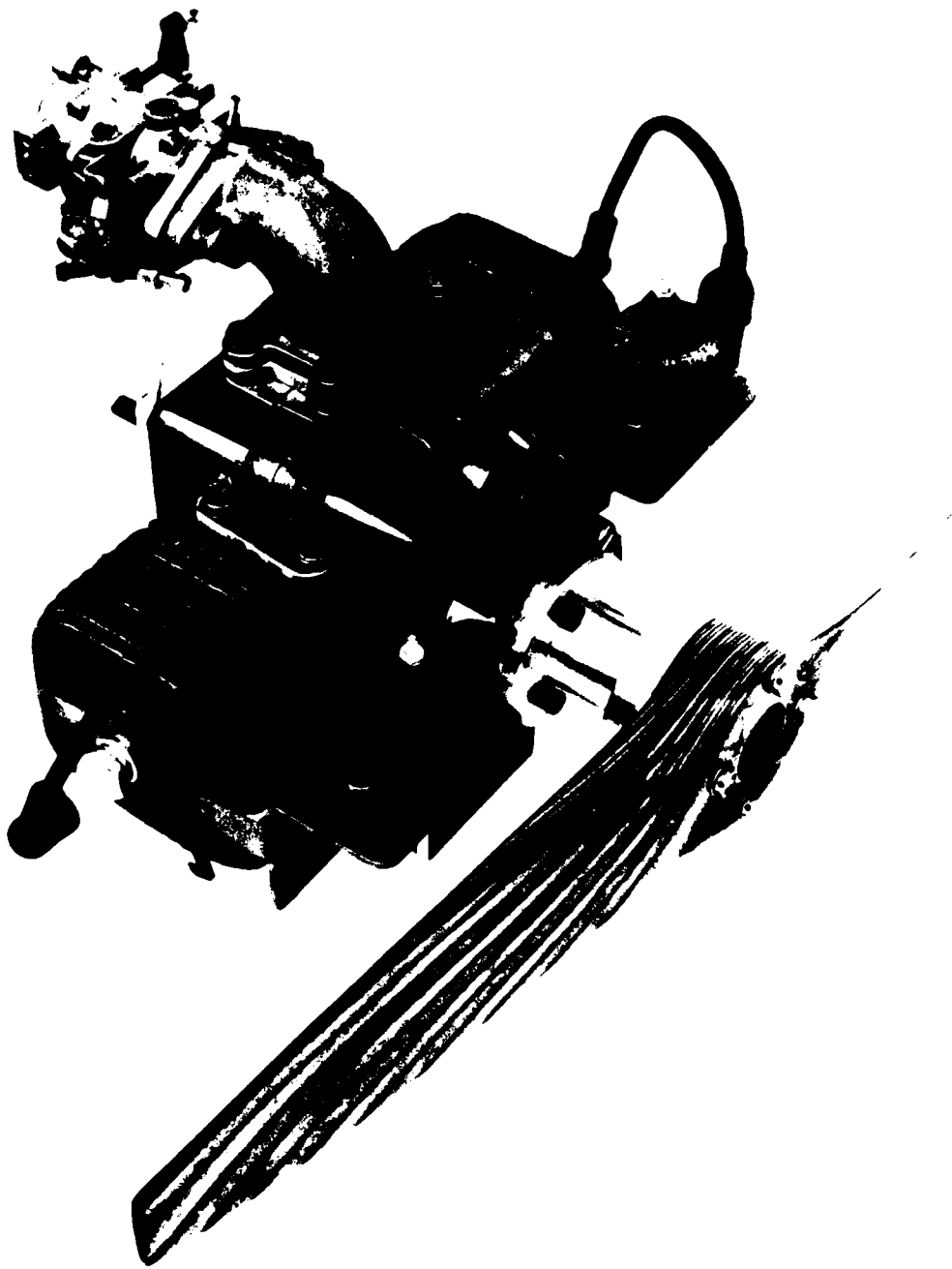


FIGURE 8. FIRST-GENERATION MK II ENGINE.

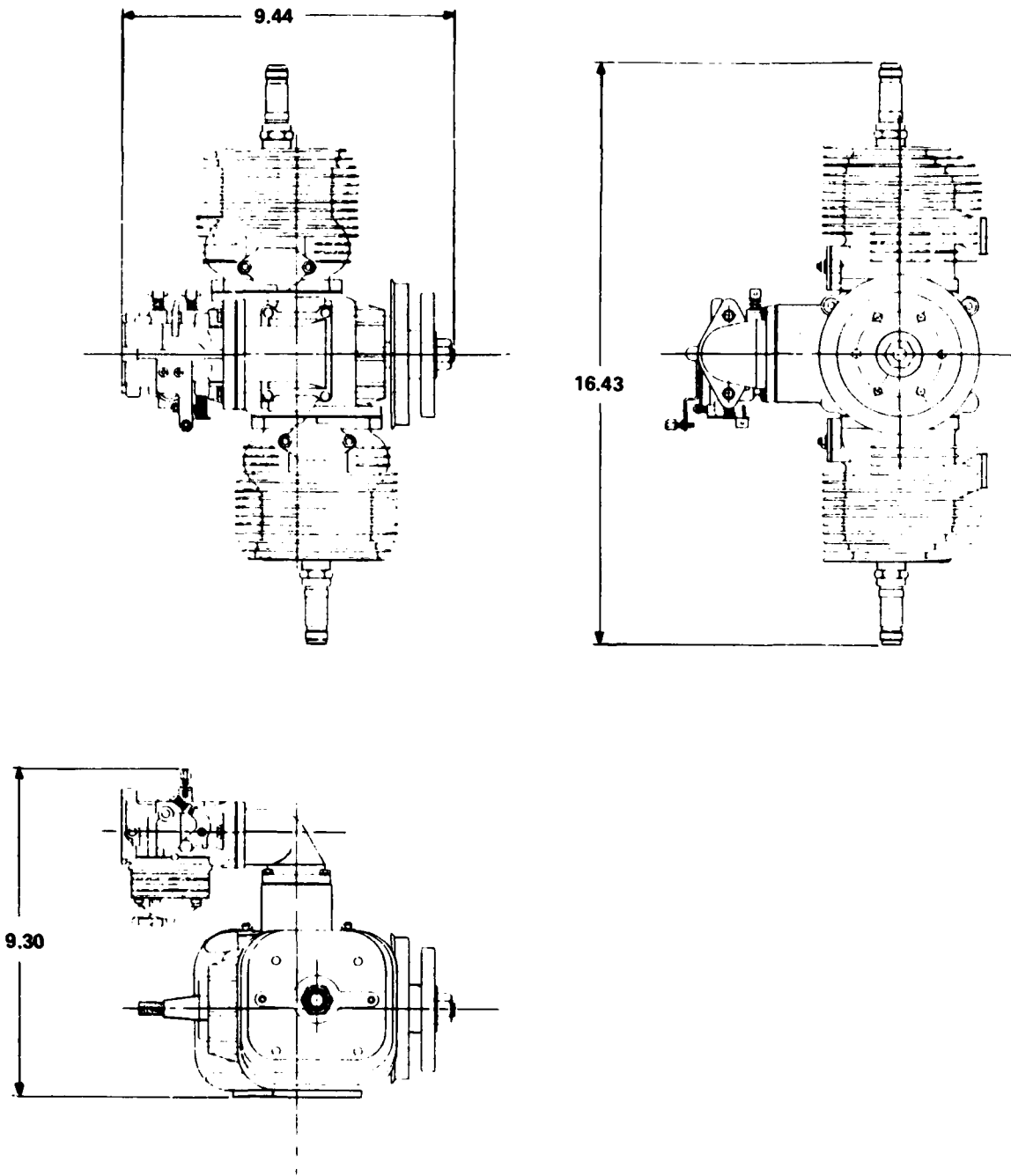


FIGURE 9. FIRST-GENERATION MK II OUTLINE DRAWING.



FIGURE 10. FIRST-GENERATION MK II EXPLODED VIEW.

## FIRST-GENERATION ENGINE TESTING

Testing of the MK II engines was conducted in a dedicated working area of the engineering development complex. Appendix C outlines the test facility and describes the instrumentation provided.

### DYNAMOMETER STAND TESTING

Testing on the dynamometer was to include selection of the induction system to be used and development of performance and operating characteristics, in relation to fuel consumption and engine cooling requirements. Initial testing used conventional mineral two-stroke cycle oil at a ratio of 20:1 fuel to oil, and regular grade automotive gasoline. The results discussed herein are based on individual test runs which best represent the test data accumulated for a given engine configuration. In all cases, horsepower data was corrected for standard day conditions. Testing of the first-generation MK II engine began with the reed inlet valve opening plugged, and the carburetor installed with the branching manifold installed for piston port induction. Figure 11 presents a WOT performance curve for an evaluation run with 24° BTDC (before top dead center) spark. Fuel/air ratio was adjusted at each speed point for best power.

For the reed valve induction system the inlet ports in the two cylinders were plugged and the reed valve system was attached to the opening on the top side of the crankcase. Preliminary testing of this installation revealed a severe flow restriction thru the reed valve assembly for operation at speeds above 6000 rpm. Removal of the reed lift stops, as a temporary expedient, reduced the flow restriction and permitted the acquisition of data (which is also presented in Figure 11) for the reed valve induction system.

Even though the piston port system developed equal power at its peak near 7000 rpm, it falls off much more rapidly at higher speed than the reed valve system. This characteristic is typical of what would be expected if the inflow wave was delayed by excessive duct length from the carburetor inlet to the cylinder port. Reducing duct length could not be conveniently remedied without two carburetors and a separate, shorter induction system for each cylinder.

For the reed valve system the power curve did not drop off as quickly at lower speed as the piston ported engine. This characteristic leads to an obvious advantage for the reed valve system. For a controllable pitch propeller application the reed valve system offers considerable engine speed reduction for equal power. Referring to Figure 11, at 90% power a reduction of 300 rpm is possible, thus creating a potential for noise reduction.

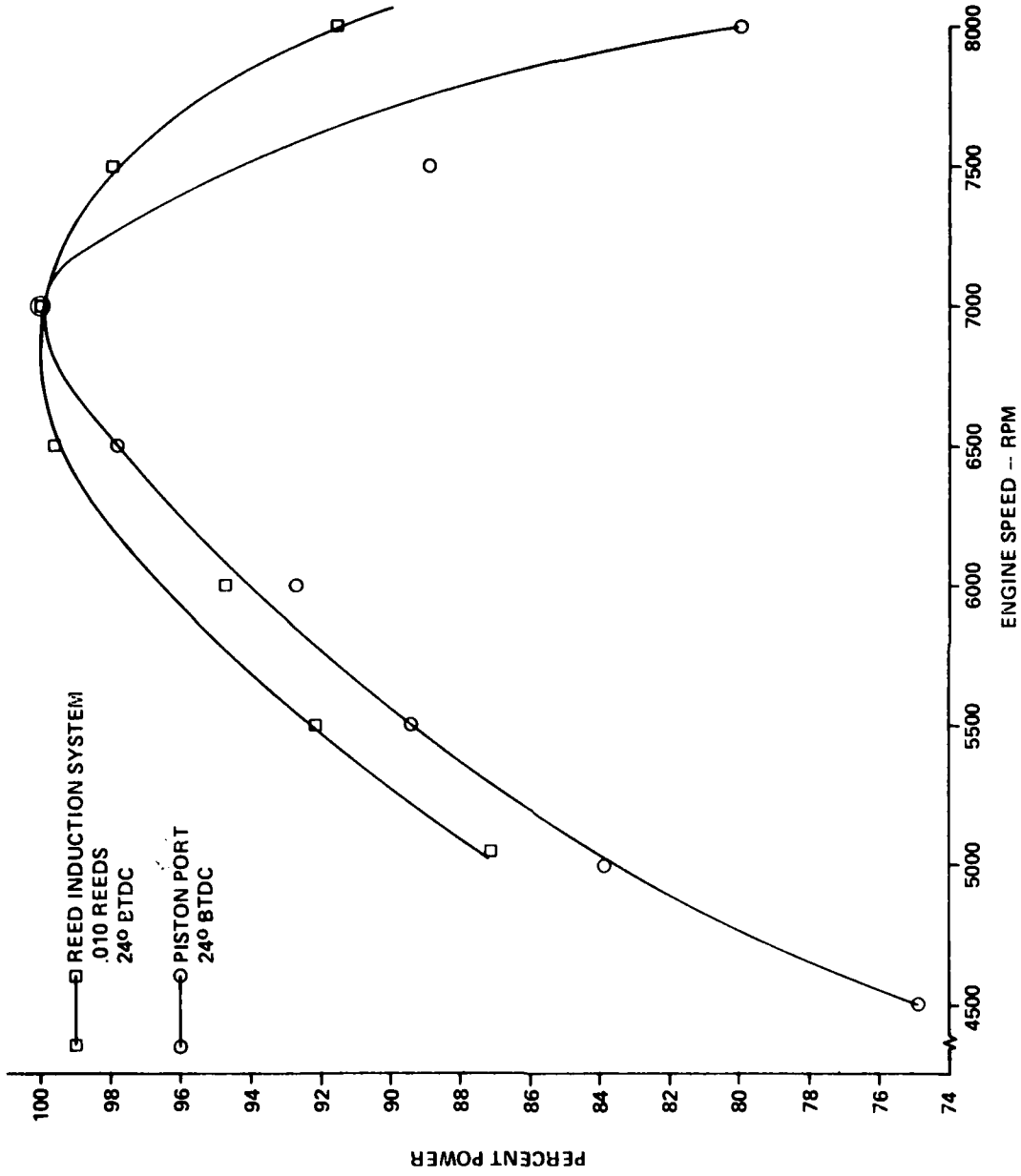


FIGURE 11. FULL THROTTLE PERFORMANCE CURVES FOR PISTON PORT & REED VALVE INDUCTION SYSTEMS AT EQUAL PEAK POWER.

The power output for the reed valve engine, in relation to delivery ratio, was somewhat higher than had been conservatively predicted, but the delivery ratio fell off more rapidly than expected. This is indicative of what would be expected if a restriction in the reed valve system reduced airflow. It was assumed, since the design of the reed cage provided freedom for flow area modifications, that the restriction in the reed valve assembly could be reduced to permit a power increase at an engine speed below 8000 rpm. To retain the simplicity of a single carburetor design the decision was thus made to select the reed valve induction system for the first-generation engine.

The following steps were investigated to increase power:

- Reed material and thickness changes
- Pyramid-shaped flow divider within the bottom of the reed cage
- Addition of side reeds on the reed cage
- Ignition timing changes

During the course of reed valve development only moderate gains in peak power were demonstrated. Results of these series of tests indicated:

- A steel reed of 0.008 thickness with backup stops of 0.300 inch appeared the best compromise for best volumetric efficiency.
- Pyramid-shaped flow divider increased peak power by only 1%.
- Addition of side reeds on the reed cage increased peak power by only 1/2%.
- Best power timing occurred at 32° BTDC, resulting in a 4% improvement in peak power.

A review of the reed inlet valve development indicates a lack of effective flow area past the open reeds. The variations in reed materials and thickness that were investigated would be expected to affect the flow during opening and closing, but the persistence of the power peak remaining near 7000 rpm suggests that the reeds were wide open against the stops during most of the flow period; hence, the flow was primarily a function of the opening area provided and relatively insensitive to the parameters that were varied. Redesign could certainly provide a substantial increase in valve flow area accompanied by a significant increase in power, but this would have constituted a major delay in engine development.

As a result of the above development tests, the first-generation engine incorporated 0.008 thick reeds with 0.300 inch

stops. Ignition timing was set at  $31^{\circ}$  BTDC, slightly retarded off of best power timing as a compromise until durability could be established through endurance testing.

Figure 12 presents a typical full throttle performance curve for the first-generation engine. Maximum power of 18.4 BHP occurred at 7000 rpm. Part throttle performance was not investigated during this period.

#### PROPELLER STAND TESTING

Testing on the propeller stand required consideration for mounting arrangements of the engine. Since the flight vehicle mounting requirements had not been defined and access to the forward crankshaft extension (for cranking) and other concessions to safety and convenience in propeller test stand operations were desirable, the mounting arrangement was devised as illustrated in Figure 13. Dynafocal mounting principles were roughly approximated with respect to torsional requirements but violated with respect to the geometry necessary for radial stiffness at the engine. Three Barry Model 5220-N vibration isolators were installed between the test stand attachment points and the engine mounting plate. The plate, in turn, was attached by four screws to bosses provided on the forward face of the crankcase.

Operational tests began with a wooden 27 inch adjustable pitch propeller in order to expeditiously define the specifications for fixed pitch propellers that would be fabricated to follow the proper cubic power to speed curve. Tests started at a coarse pitch of  $20^{\circ}$  with consecutive fining of the blades to  $10^{\circ}$  pitch. This effort was fraught with problems of thrown blades, bent crankshafts and damaged test cell equipment, but resulted in a fixed pitch wooden propeller of 28 in. diameter and  $15^{\circ}$  pitch (at 75% radius) that absorbed the contemporary maximum power of 18.7 BHP at 6900 rpm. The static thrust ratio of this propeller was 4.8 pounds per horsepower.

A series of piston scuffing was also experienced in the early propeller test stand operation. In retrospect, this was attributed to the lean mixtures inadvertently run during carburetor calibration. The high exhaust gas temperatures that can result from lean operation with reduced power were not initially measured, and as a result, the closely monitored cylinder head temperature implied a comfortable thermal margin.

#### ENDURANCE STAND TESTING

With respect to engine mounting, cooling air and starting provisions, engine controls, etc., the endurance test stand was similar to the propeller test stand described in Appendix C. However, the mounting and instrumentation did not provide for propeller thrust measurements.

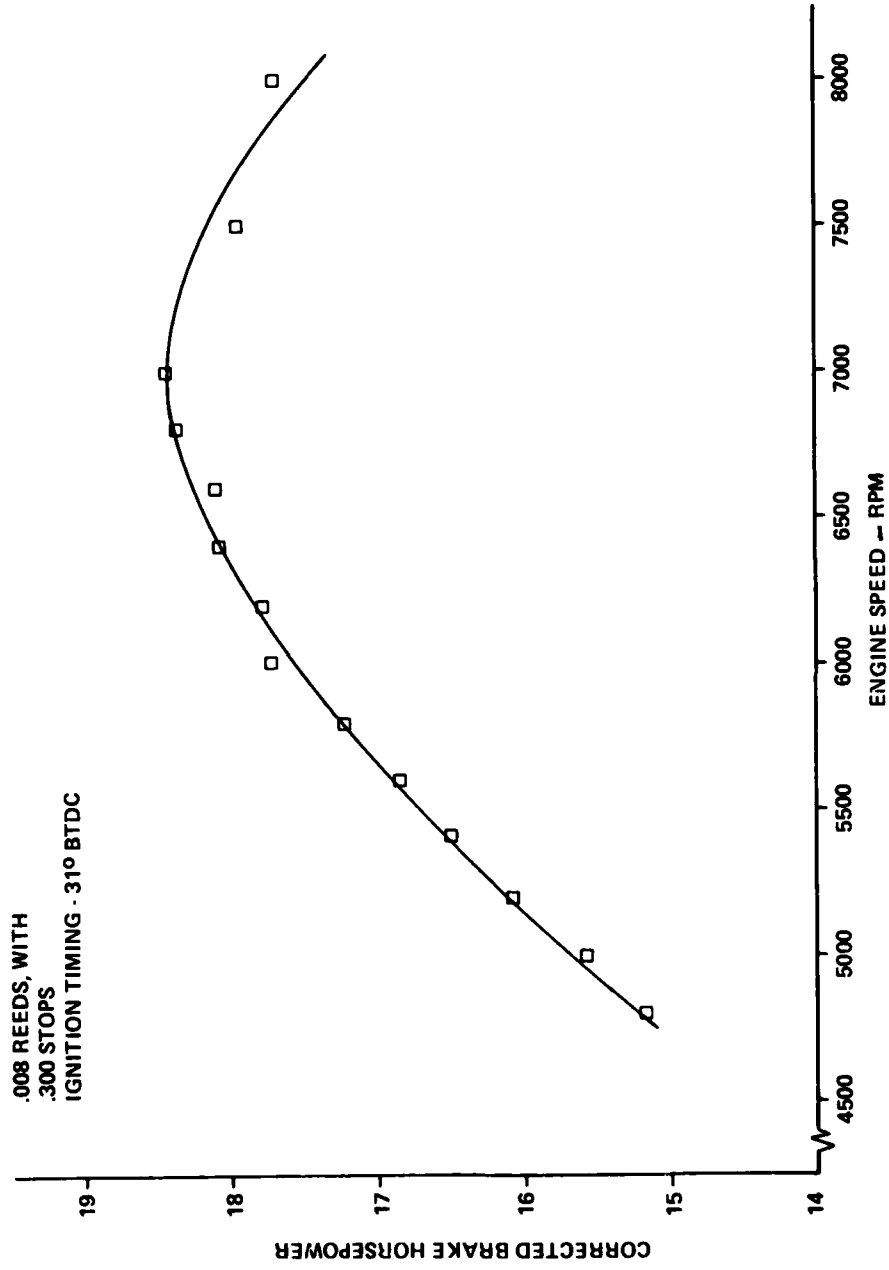


FIGURE 12. FULL THROTTLE PERFORMANCE CURVE FIRST-GENERATION ENGINE.





FIGURE 13. MK II ENGINE MOUNTING PLATE.

The objectives of the endurance testing were the accumulation of 150 hours of operation under the following duty cycle with a minimum number of failures and the elimination of those failures by component improvements and/or acceptable scheduled maintenance or replacement of critical parts.

<u>MODE</u>	<u>POWER LEVEL</u>	<u>TIME IN MODE (Min.)</u>
Start & Idle	Idle	1
Takeoff	100%	3
Climb	90%	10
Cruise	75%	60
Approach	Idle	2
Landing Abort	100%	2
Cruise	75%	2
Idle & Shutdown	Idle	2

Results from the first 150-hour endurance run are presented in the following synopsis:

● Failures causing temporary engine shutdown:

- (1) At 55.02 hours - propeller hub failure - this failure resulted in the loss of the propeller hub and a Sen-senich wooden propeller and required replacement of the ignition rotor.

- (2) At 78.19 hours - #2 cylinder crankpin bearing failure - resulted in scoring the crankshaft, however, the thrust bearing on the end of the crankcase was also replaced because of excessive heat signs.
- (3) At 96.43 hours - second propeller hub failure - resulted in loss of propeller hub and Sensenich wooden propeller, however, no engine damage occurred.
- (4) At 102.10 hours - #2 piston/cylinder seizure - resulted in loss of complete cylinder assembly. The seizure was attributed to overleaning of the fuel/air mixture as a result of carburetor adjustment.
- (5) At 128.46 hours - carburetor choke shaft broke - resulted in damage to the crankcase reed cage assembly because the choke butterfly retaining screw lodged between the reed valve and reed cage block assembly.

● Parts which survived the full 150-hour endurance test were:

- |   |   |
|---|---|
| (1) Crankcase                               | (8) Carburetor  |
| (2) Rods (Cyl. 1 - #025<br>Cyl. 2 - #010)   | (9) Intake Manifold   |
| (3) Piston Pin Bearings<br>(both cylinders) | (10) Crankshaft Main Bearings                                 |
| (4) Piston Pins<br>(both cylinders)         | (11) Thrust Bearing & Washer<br>(Propeller end)               |
| (5) Piston Rings<br>(#1 Cyl. - #037)        | (12) Crankcase Bearing Seals                                  |
| (6) Ignition Module                         | (13) #1 Piston and Cylinder<br>Assembly (#037-020)            |
| (7) Ignition Coil                           | (14) Spark Plugs - Cyl. 1 and<br>Cyl. 2<br>(Surface Gap Type) |

● Original parts which were replaced and substituted parts which finished the endurance test were:

<u>ITEM</u>	<u>HOURS</u>	<u>REMARKS</u>
(1) 1st Crankshaft #002	78.19	Replaced because of #2 rod split cage bearing failure.
2nd Crankshaft #005	71.81	Finished endurance cycle.
(2) #2 Piston and Cylinder Assembly (#045-002)	102.5	Replaced because of seizure due to lean mixture operation.
#2 Piston and Cylinder Assembly (#016-012)	47.50	Finished endurance cycle.
(3) First set of Rod Split Cage Bearings	78.19	Replaced when 1st crankshaft (#002) was replaced, the #2 split cage bearing cracked its cage.

(4)	Carburetor Choke	128.46	Replaced because of choke shaft breakage.
	2nd Carburetor Choke	21.54	Finished endurance cycle.
(5)	Carburetor Throttle Shaft	80.41	Vibration fatigue.
	2nd Throttle Shaft	69.59	Finished endurance cycle.
(6)	Reed Block Assembly	128.46	Replaced because of choke shaft failure.
	2nd Reed Block	21.54	Finished endurance cycle.
(7)	Ignition Rotor	55.02	Replaced because of prop hub failure.
(8)	Crankshaft Thrust Bearing and Washer Forward End	78.19	Replaced with #005 Crankshaft.
	2nd Thrust Bearing and Washer Forward End	71.81	Finished endurance cycle.

● Major problem areas were thus identified as follows:

- (1) Propeller and/or attachment failure.
- (2) Piston to cylinder seizure.
- (3) Crankpin bearing failure.

#### PROPELLER AND ATTACHMENT PROBLEMS

These difficulties arose from the very high cyclic torque variations that are common to this engine configuration. Excessive stress variations can induce a fatigue-type of failure and the actual cyclic torque reversals can result in progressive yielding and/or delamination.

The primary problems with the propeller installation were traceable to the difficulties encountered in maintaining adequate frictional contact between the metal hub flanges and the wood surfaces of the propeller. The compressibility of the wood invalidated various attempts to maintain a proper friction drive resulting in a loss of torque load on the clamping bolts thru the propeller. The inevitable impact loading resulted in progressive bearing failure of the wood around the bolts and/or bending failure of the bolts near the flanges.

The solution lay in providing pins shouldered in the metal flanges and passing through the propeller, thus controlling the clamping forces. The applied torque could therefore be transferred without the required normal force excessively crushing the wood.

## PISTON - CYLINDER SEIZURE

The piston seizures that were experienced during the endurance testing were attributed to one or an interrelation of the following causes:

- Insufficient external air cooling.
- Insufficient internal fuel cooling.
- Thermal distortion and lubrication.
- Piston ring sticking and resultant blow-by.

The Stihl 090 cylinders were intended for effective blower cooling in their accustomed chain saw application. It was thus anticipated that the MK II engine application would require supplemental internal fuel cooling by increasing fuel/air ratio above the minimum BSFC requirement and possibly even above that corresponding to maximum power. Until the reality that critical exhaust gas temperatures do not necessarily drop along a propeller load curve was recognized, various attempts to minimize the cruise specific fuel consumption led to thermal difficulties. Proper installation of an exhaust gas thermocouple provided a much more reliable parameter to be monitored than the formerly used spark plug base temperature. A premonition of impending seizure was thus provided, since gas temperature (which was the cause) rather than surface temperature (which was the effect) could be observed.

Piston seizure can result solely from the reduction of film strength of the lubricant, caused by high temperature or more likely by the combined effect of a diametrical expansion or thermal distortion (of the piston and/or cylinder) increasing the unit loading. Thus, not only are the average and peak temperatures of concern, but the temperature distributions throughout the entire cylinder and piston. These factors were considered in the MK II development only with respect to establishing conservative exhaust gas temperature limits. A sophisticated investigation of heat transfer from the piston to the cylinder and from the cylinder to the cooling air, and of the complex distortion of the cylindrical surfaces that results, could lead to safe operation at higher gas temperatures and lower specific fuel consumption for this air-cooled cylinder.

Initial endurance testing using Castrol brand two-stroke cycle injector type oil at a ratio of 20:1 fuel to oil resulted in a considerable problem of piston ring carbon sticking. This occurred after running for periods of from 10 to 50 hours when operating over the prescribed duty cycle. Usually this problem, after it fully developed as a stuck piston ring, would also lead to complete seizure of the piston in the cylinder. The piston seizure was caused by combustion gases escaping past the ring,

which overheated the piston and led to failure in a manner similar to the effects of thermal distortion described above.

A period of experimental tests conducted at fuel to oil ratios of 30:1 and 40:1 yielded extended intervals of running. A period of 50-60 hours of tests could be endured before removal and cleaning of the ring was required.

The insidious aspect of piston seizure is that not only are all the above listed causes potentially accumulative, but once initiated, a positive feedback effect is most likely to result. There is then an immediate seizure of the piston with a smearing of the sliding surfaces which destroys all evidence of the original cause. This situation is particularly exasperating in the testing of multicylinder engines or engines with considerable flywheel inertia, where rotation can continue for some time in spite of the rapidly rising drag.

#### CRANKPIN BEARING CAGE FAILURE

After some 40-60 hours of endurance cycling with the 40:1 fuel to oil ratio (that was used to reduce piston ring sticking to a tolerable level), failures of the split cages for the crankpin bearing rollers became evident. Split cages are notoriously unpredictable in high speed applications, and because of deflections, tolerances, lubrication or other applicational or operational differences, these cages obviously were not enjoying the chain saw engine environment for which they were designed.

Microscopic examination of a typical bearing cage, indicated that it was not receiving adequate lubrication and was wearing so thin that it would crack and break apart. This failure invariably occurred at the tip ends of the two-piece bearing cage where it was found to have the least effective heat treatment. A Rockwell hardness test conducted on the cage showed 40-50 "C" hardness in the center of the cage compared to 10-15 "C" hardness at the tip ends.

In discussing these heat treatment variations of the bearing cages with the manufacturer, it was determined that the cages TCM were using were within normal production variations. It was consequently decided that the quickest and least expensive method of reaching a solution was to provide better lubrication to the bearing by drilling additional oil holes in the connecting rod.

Propeller cell endurance tests indicated that life expectancies of 50-100 hours could be obtained by the addition of the oil hole in the rod, but that inferior heat treatment of the bearing cage still made it quite sensitive to the inevitable effects of wear.

## SECOND-GENERATION ENGINE DESIGN

Anticipating eventual RPV requirements for an on-board electrical power supply in the form of an engine driven alternator, the contract was modified to design, fabricate, and install as an integral part of the engine package an alternator that would meet the following objectives:

- (1) 900 watts minimum at cruise (nominally 7.5 hp).
- (2) 400 watts minimum at approach (4000 RPM).
- (3) Direct coupling to the engine with a maximum speed of 8000 RPM.
- (4) Design should use MIL-STD-461 Notice 6 as a guide.
- (5) Voltage power of 28 volts D.C.  $\pm 2$  volts.
- (6) Minimum life expectancy of 150 hours.
- (7) Weight of the system not to exceed 7 lbs.

### ALTERNATOR - IGNITION SYSTEM

The added alternator requirement indicated the desirability of integrating the ignition system with the alternator and electrical power conditioning package for mounting convenience and in order to reduce installed weight for the total system.

The R.E. Phelon Company was selected to provide this combined ignition and electrical power supply unit which would use high production electrical components and known state of the art to provide an assembly of light weight, yet reasonable cost, that would be suitable for general RPV application.

The ignition circuitry would receive its electrical power from one phase of the three-phase alternator system, and the specified ignition characteristics were as follows:

- (1) Output high tension voltage = 30,000 volts
- (2) Rise time @ plug = 5 microseconds
- (3) Spark plug resistance = 10,000 Ohms
- (4) Spark plug type - Champion RMJ-3
- (5) Spark current and duration = 300 MA, 75 microsec.
- (6) Timing =  $31^{\circ}$  BTDC

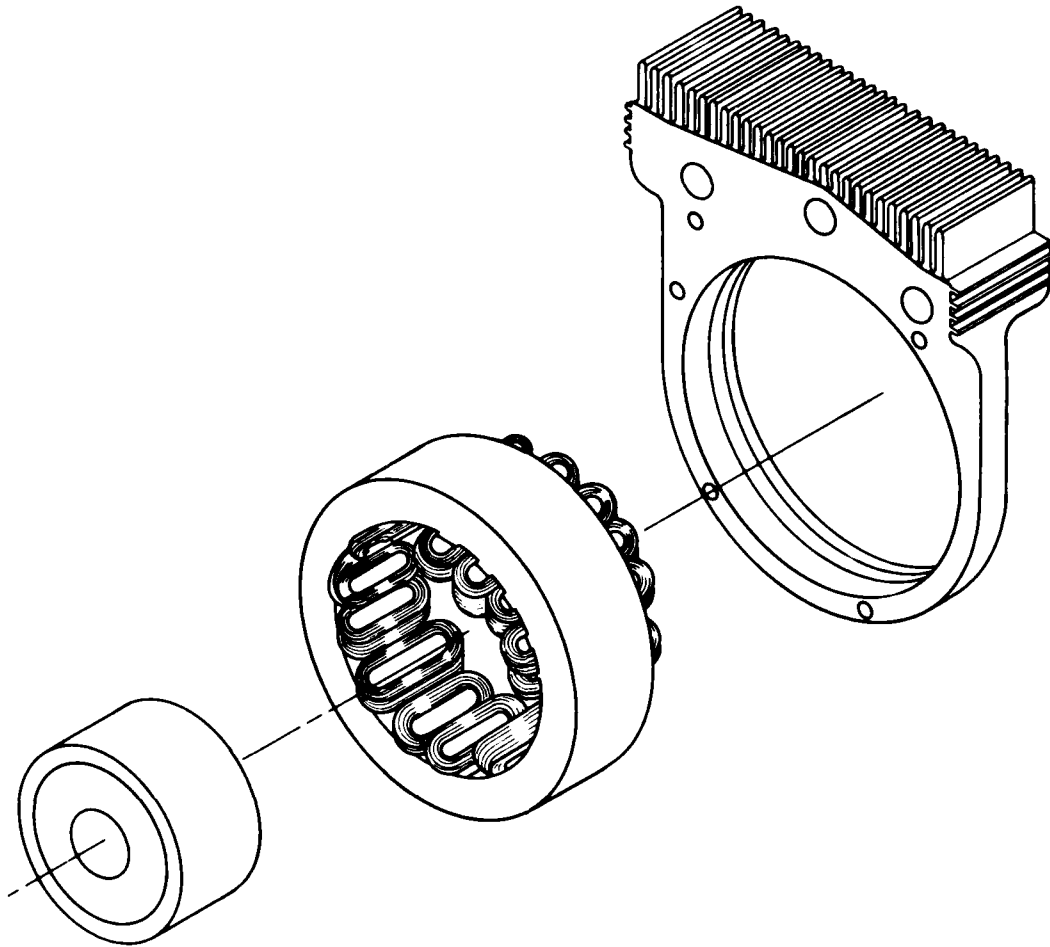
For lightweight, compact design, the alternator would use a crankshaft-mounted rotor with samarium-cobalt magnets. This would provide excitation for the three-phase delta connected stator coil assembly which would be mounted rigidly onto the engine crankcase along with the combined ignition stator and power conditioning elements. The combined system includes a rotor, stator assembly and power conditioning unit (PCU).

The rotor is a unique design with the samarium-cobalt magnets contained in a carrier, which acts as an array of pole pieces. The individual magnets are inserted into the stack of carrier stampings and then an aluminum housing is cast around this sub-assembly and a central steel hub. This solid rotor assembly is then bored to fit the crankshaft taper and machined on the outside diameter in the same lathe setup to expose the magnet carrier poles and insure concentricity of the air-gap surface.

The stator, shown in Figures 14 and 15, utilizes laminations of silicon steel to provide appropriate flux paths thru the coils. To improve efficiency, the design of this magnetic circuit provides multiple paths for flux emanating from each rotor magnet pole. This flux passes in the proper direction thru several stator coils and then returns to the opposite poles of both the same and adjacent magnets. The stack of stator laminations is welded together in longitudinal grooves along the periphery. These welds are confined within the O.D. to eliminate the necessity of extra machining. The individual stator coils are delta connected to provide the three-phase alternator output.

The stator mounting system incorporates a pilot boss on the engine which centers an intermediate stator mounting ring on its inboard side. This cast ring, in turn, pilots onto the stator and the power conditioning unit on the outboard side of the ring. The cast housing for the PCU places its components in close proximity to the alternator coils and allows electrical connections to be short and permanent. All silicon controlled rectifiers, diodes, filters and wire connections are epoxied solidly in place to improve heat transfer and minimize the effects of vibration. The PCU housing is surrounded by fins to provide sufficient cooling to keep the electrical control components well within their thermal ratings.

The PCU consists of a full wave switching bridge, a series of SCR's and diodes, a voltage sensor, and a filter to minimize electromagnetic interference (EMI). Output is regulated at 28 volts D.C. over the complete load and speed range. The PCU consists of standard production circuitry and incorporates only those installation modifications necessary to satisfy the requirements of this application. Output current is filtered to control ripple and to suppress EMI emission. The PCU is protected against short circuit output by means of its current limiting



**FIGURE 14. ALTERNATOR WITH INTEGRATED PCU.**

ability in maintaining the voltage level. A simplified block diagram of the alternator and power conditioning system is presented in Figure 16.

Figure 17 shows the integrated stator assembly and mounting, power conditioning unit and ignition system. The stator elements for the alternator and ignition system, as well as the electrical power conditioning components, had been packaged in a case to be mounted on the bosses provided on the original crankcase design. Concentricity was established by the piloting spigot around the rear main bearing seal, for an intended rotor to stator air gap of 0.015 inch.



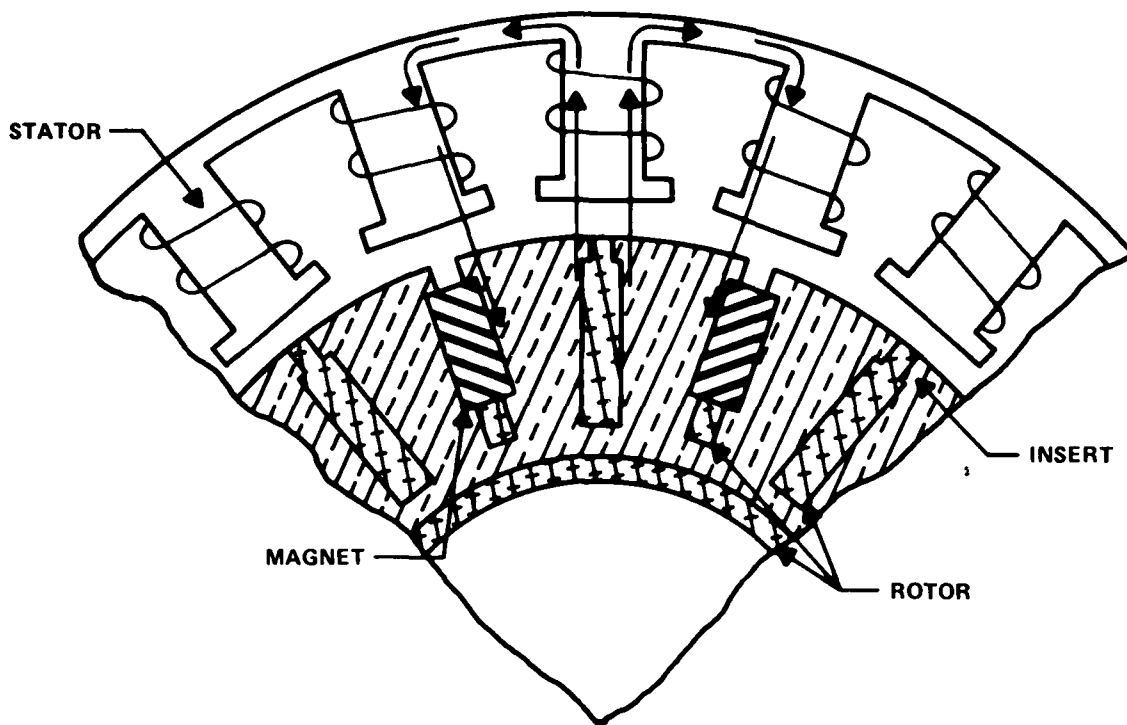


FIGURE 15. ROTOR CONSTRUCTION AND FLUX PATH.

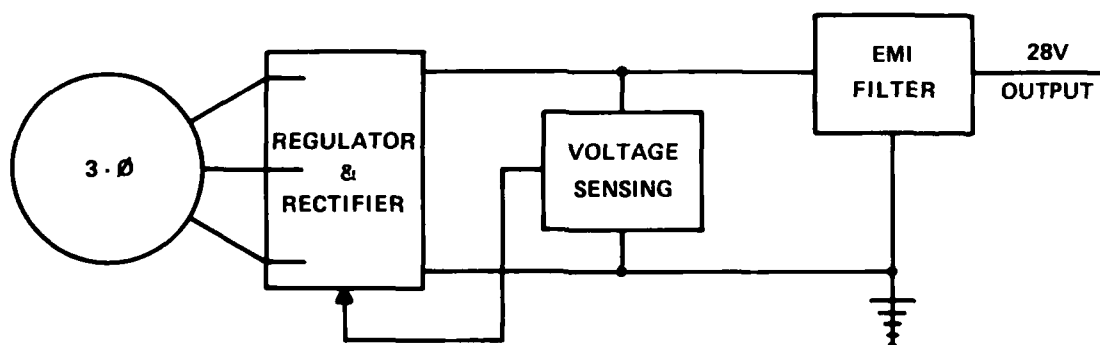


FIGURE 16. ALTERNATOR SCHEMATIC DIAGRAM.



FIGURE 17. ALTERNATOR DESIGN.

#### CRANKSHAFT

The crankshaft was lengthened (identically on both ends) and the taper angle was reduced for better attachment of the alternator/ignition rotor. The crankpins were drilled out in an attempt to minimize the weight increase in the longer shaft. This second-generation crankshaft is depicted in Figure 18.

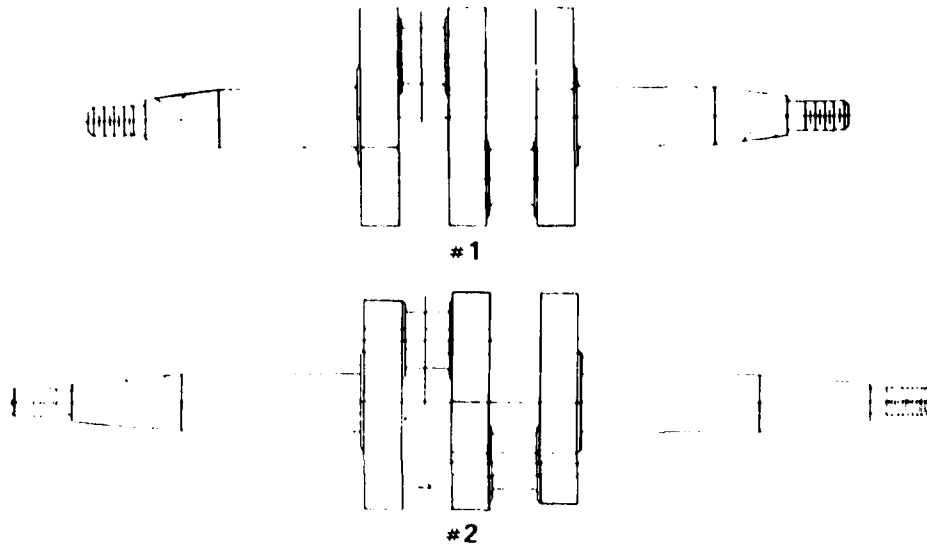
The magnet rotor assembly was mounted on the crankshaft taper and its overhanging aft extension provided a mounting face for the propeller and working clearance with respect to the stationary components of the ignition unit.

#### CRANKCASE

Due to severe rubbing between the stator and rotor elements, (covered under Second-Generation Engine Testing) the crankcase was modified with a steel bearing boss as shown in Figure 19. This pressed-in steel insert accepted longer main bearings that were more widely spaced for better crankshaft support, and reduced the moment arm of the overhung propeller and rotor mass. This reduced the deflections so that rubbing could be avoided and electrical output requirements satisfied (for starting) with an air gap clearance (static) of 0.020 inch.

#### ENGINE ASSEMBLY

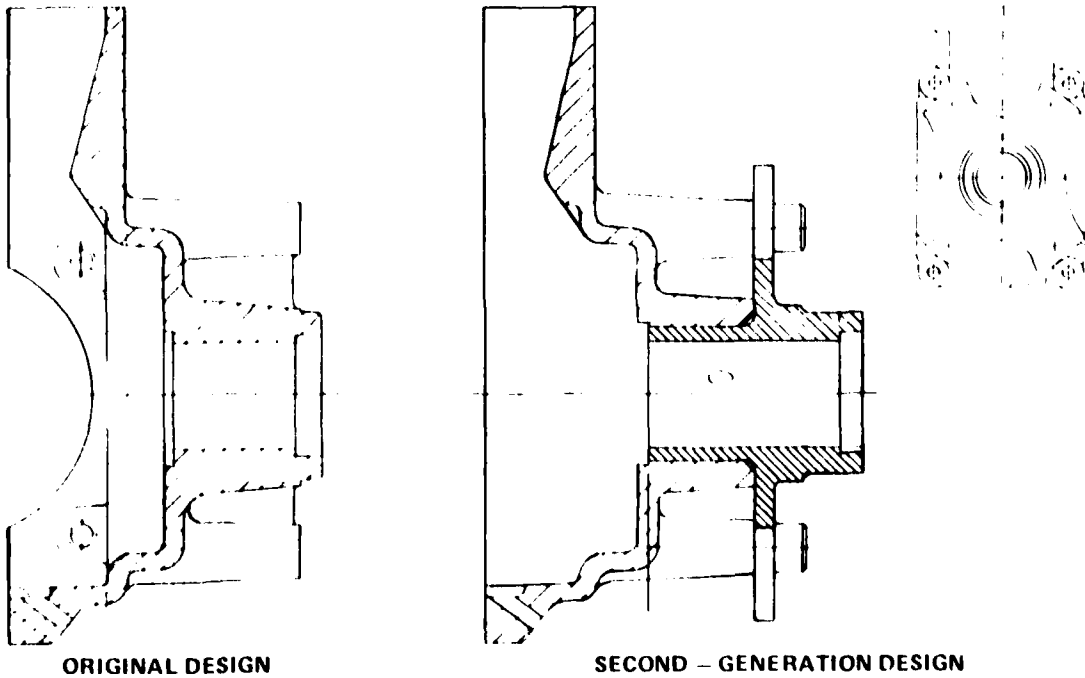
Figure 20 depicts the second-generation MK II engine as configured with the reed valve induction system, and combined alternator-ignition - PCU system. The total engine package weighed 26 pounds with external dimensions of 12.63 inches in length, 19.25 inches in width, and 9.5 inches in height.



**BASIC MODIFICATIONS**

- # 1 ORIGINAL DESIGN – 14° TAPER ON MAIN SHAFT
- # 2 EXTENDED MAIN SHAFT FOR ADDITION OF ALTERNATOR – CHANGE TO 10° TAPER

**FIGURE 18. MK II CRANKSHAFT DESIGN CHANGES.**



**ORIGINAL DESIGN**

**SECOND - GENERATION DESIGN**

**FIGURE 19. MK II CRANKCASE BEARING SUPPORT CHANGES.**

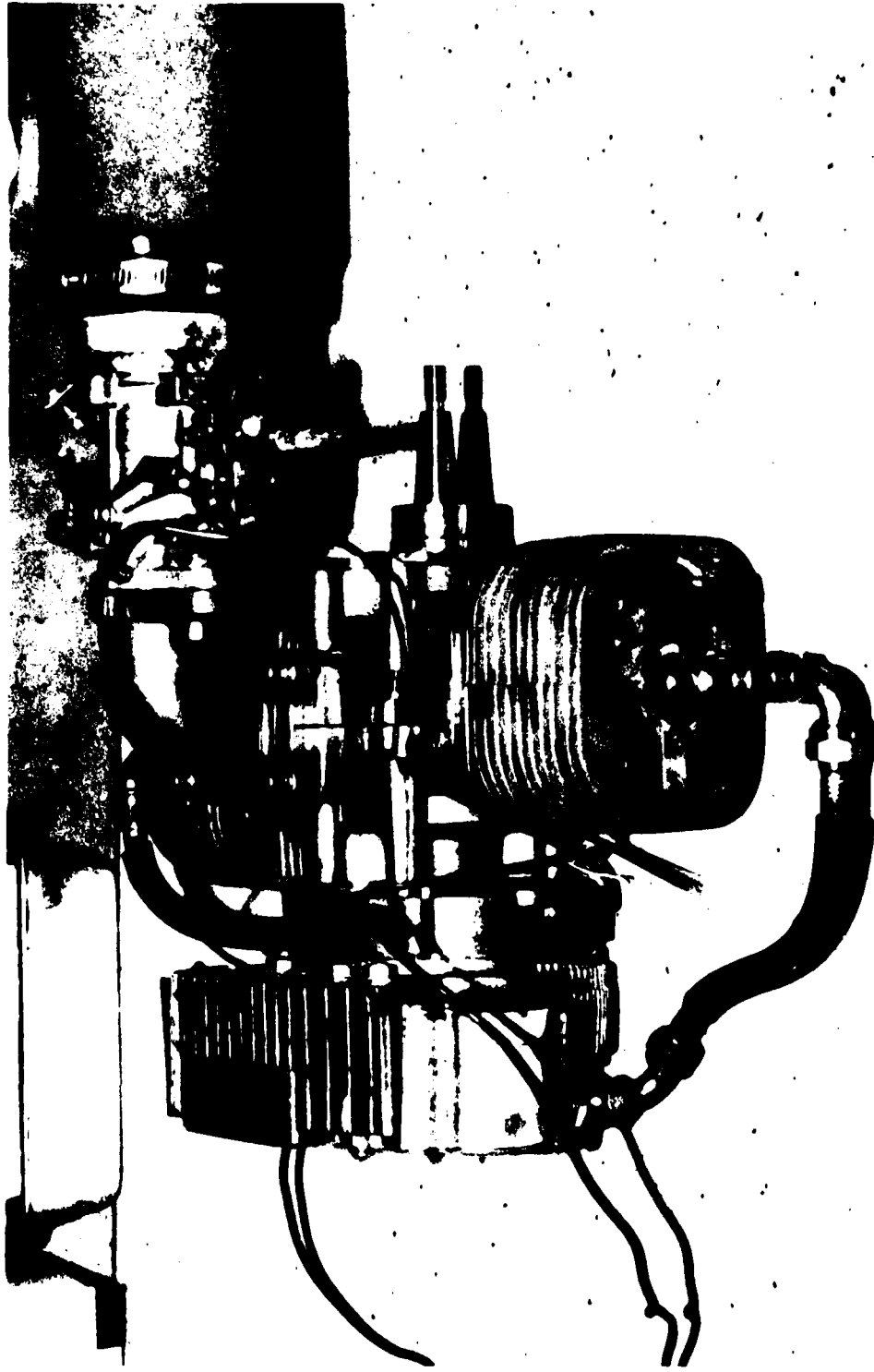


FIGURE 20. SECOND-GENERATION MK II ENGINE.

## SECOND-GENERATION ENGINE TESTING

### PROPELLER STAND TESTING

Initial running of the second-generation engine assembly on the propeller test stand revealed severe rubbing between the stator and rotor elements. In an effort to expedite the testing, the air gap clearance was increased. A static clearance of 0.030 inch was required to eliminate rubbing contact, however; at this point alternator performance had deteriorated sufficiently to make engine starting rather difficult because of low ignition voltage.

In static tests, a radial load was applied at the propeller flange to simulate the forces due to propeller unbalance. Measurements of deflection in the region where rubbing contact occurred indicated the intended air gap of 0.015 inch was nonexistent with an applied radial load of 150 pounds. Additional tests were conducted to determine which component needed to be modified. The results indicated 60% of the deflection was caused by the crankcase, while 8% and 32% were attributed to the bearing and crankshaft respectively. In an effort to minimize the crankcase deflection a steel bearing hub was designed to be pressed into the existing crankcase. In addition, the steel bearing hubs incorporated an extension of the bearing support area allowing the bearing to move outboard by 0.82 inch. Deflection tests of the modified crankcase showed approximately 50% improvement in crankcase rigidity. This reduced the deflections so that stator-rotor rubbing was completely voided.

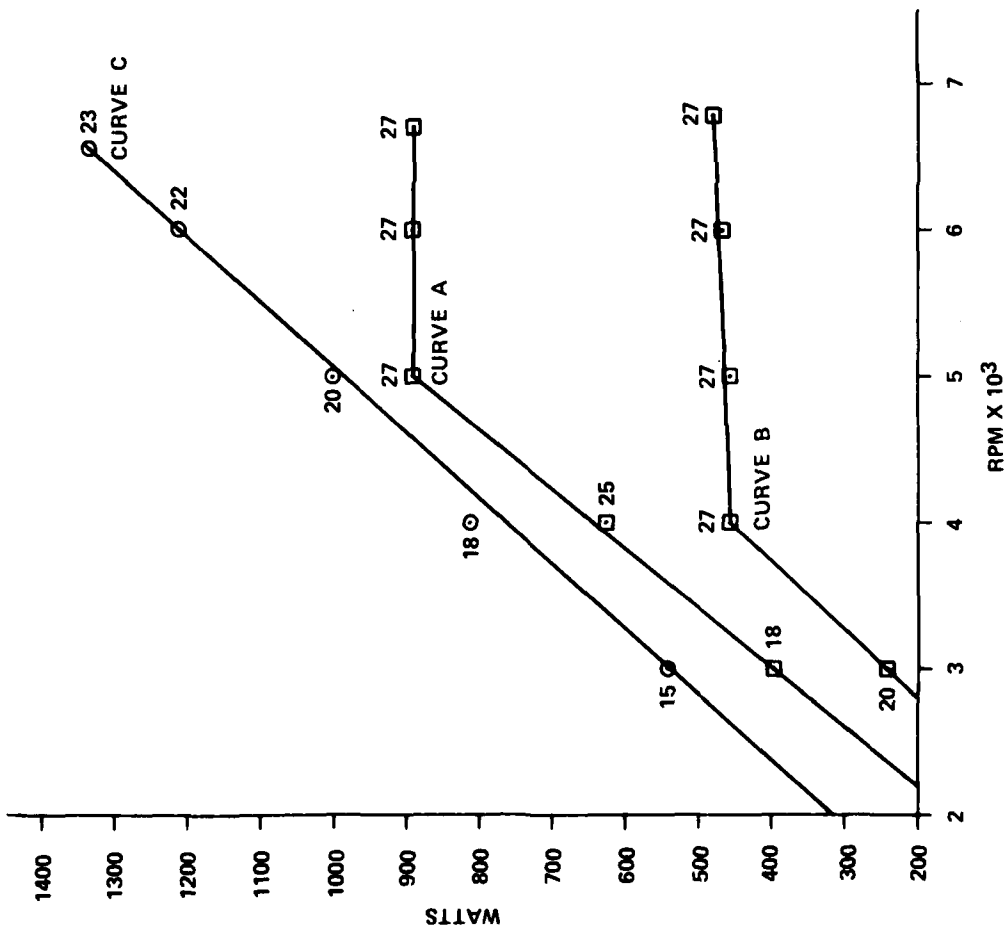
Operation on the propeller test stand was continued with the modified crankcase engine and the combined ignition, alternator and power conditioning unit installed and feeding a test cell resistance load. The system demonstrated compliance with contractual requirements as shown in Figure 21.

Curve (A) corresponds to the requirement for 900 watts minimum at cruise power (7.5 HP) at a constant 28 (+2) volts D.C. Curve (B) relates to the requirement for 400 watts minimum at engine speed during approach (4000 RPM). Curve (C) shows the electrical power and voltage output when the total available resistance load was applied.

### DYNAMOMETER STAND TESTING

Dynamometer testing of the second-generation MK II engine began with a battery ignition equipped engine so that a baseline for comparison with the combined alternator-ignition system engine would be available. Ignition timing of the engine was accomplished with a Mallory photocell switch mounted on the crankcase and a slotted disk mounted on the back of the propeller flange.

The full throttle data on Figure 22 show the relationship between corrected horsepower output and speed, fuel consumption,



□ = MEETS ARMY CONTRACT REQUIREMENTS  
 ○ = TCM TEST EQUIPMENT CAPABILITY AS MEASURED BY TCM

NUMBERS SHOWN ON CURVE ILLUSTRATE VOLTAGE OUTPUT AT THAT POINT.

5000 RPM = 7.5 BHP - PROP LOAD CURVE USING SENSENICH WOODEN PROPELLER.

FIGURE 21. PHELON ALTERNATOR OUTPUT.

air-fuel ratio, cylinder spark plug temperature and exhaust gas temperature. The data was generated maintaining a cooling air  $\Delta P$  (pressure drop) across the cylinders of 4.5 inches of water.

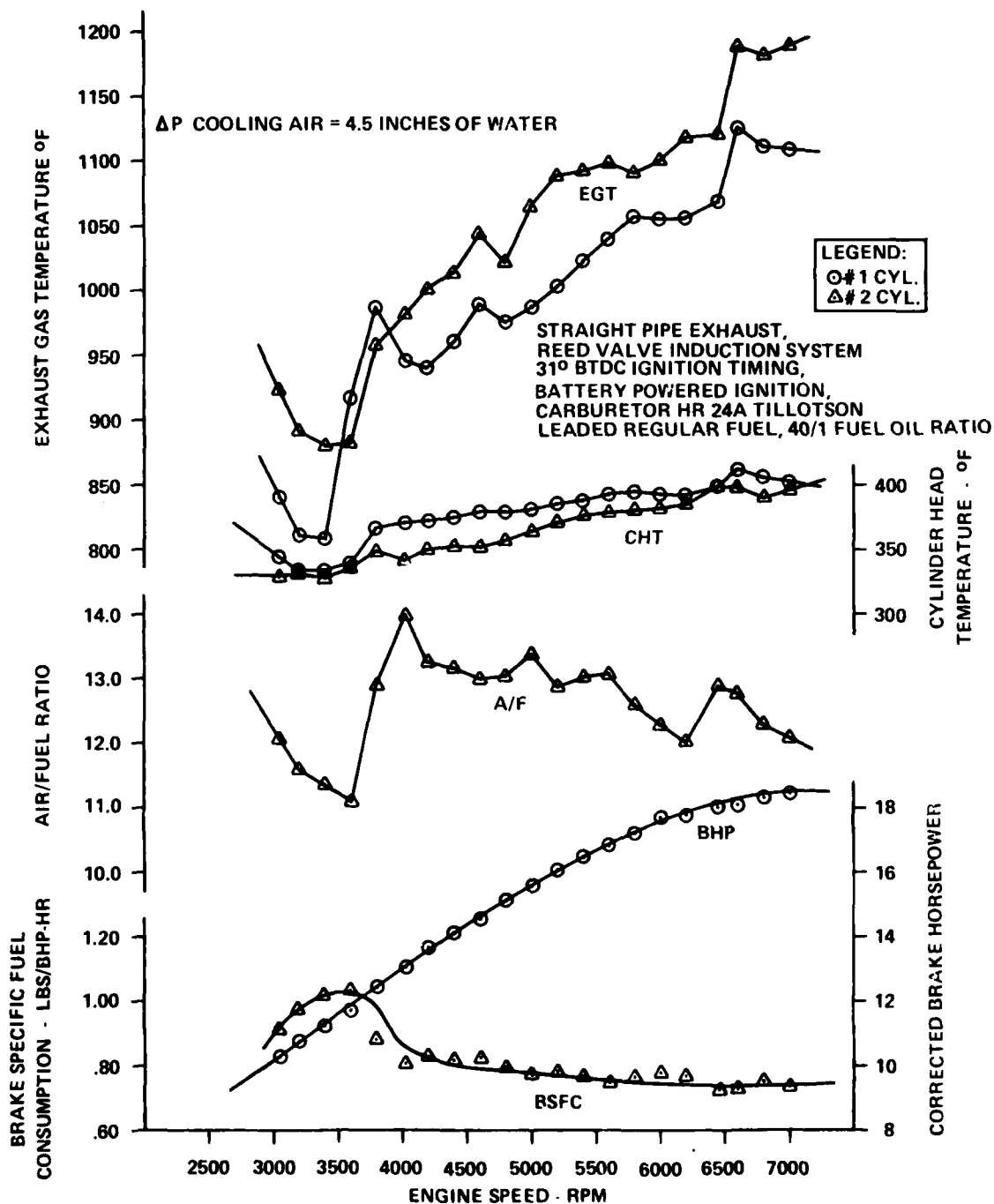


FIGURE 22. SECOND-GENERATION ENGINE FULL THROTTLE CURVE.

With this adequate external cooling airflow the WOT breathing limited power could be maintained without richening beyond the best power air-fuel ratio of approximately 12 to 1. At WOT, there is an inherent delivery ratio increase at lower speed, so more of the hot residual gas was removed, thus lowering the initial temperature before compression in spite of a higher BMEP. This and other favorable heat balance factors resulted in a reduction of exhaust gas temperature (which is very critical for the survival of piston and cylinder surfaces near the exhaust port) of some 300° F for a speed reduction from 7000 to 3000 rpm. For the same speed range the cylinder head temperature, which is normally monitored for a warning of thermal distress, dropped only some 50°.

In contrast, Figure 23 shows the effects of throttling along a simulated propeller load curve. In this case the air-fuel ratio was allowed to follow the characteristic of the carburetor with its metering jet remaining as adjusted for maximum power at 7000 rpm. With throttling, less of the hot residual gas was eliminated by the scavenging process and the initial temperature before compression rose to offset the reduced fresh charge of combustible mixture. The result, to the detriment of BSFC at cruise conditions, was that the critical exhaust gas temperature became almost solely dependent upon air-fuel ratio. If supplemental fuel cooling were required at full power, it is likely to also have been required at cruise. Furthermore, as shown in Figure 23, the monitored cylinder head temperature dropped almost 100° F for a reduction of engine speed from 7000 rpm to 5000 rpm, while exhaust gas temperature was substantially the same at these two speeds. Because of this and because of its slow response, cylinder head temperature leaves a lot to be desired as an indicator of impending thermal problems in the proximity of the exhaust port.

After the baseline engine was tested, the engine was converted with the combined alternator-ignition system and mounted on the dynamometer for determination of its performance characteristics. Figure 24 illustrates the WOT shaft and electrical outputs that were available, as a function of rpm. The corresponding BSFC's that are shown are based on net shaft power without consideration of the simultaneous parasitic electrical load.

As expected, the exhaust gas temperatures and cylinder head temperatures behaved similarly to the baseline engine. Comparing Figures 22 and 24 at a given engine speed, the efficiency of the alternator-ignition system can be determined. For example, at an engine speed of 5000 rpm the baseline engine produced 15.6 horsepower while the alternator-ignition engine loaded at 1000 watts developed 13.5 horsepower, resulting in an alternator-ignition efficiency of 64%.

Figure 25 is for the same configuration, but with throttling, from the 7000 rpm WOT point (with a constant electrical load) down along a simulated propeller load curve. Figures 23 and 25 can be compared for similarity.



STRAIGHT PIPE EXHAUST, REED VALVE INDUCTION SYSTEM  
 31° BTDC IGNITION TIMING, BATTERY POWERED IGNITION  
 CARBURETOR HR. 24A TILLOTSON  
 LEADED REGULAR FUEL, 40/1 FUEL OIL RATIO  
 ΔP COOLING AIR = 4.5 INCHES OF WATER

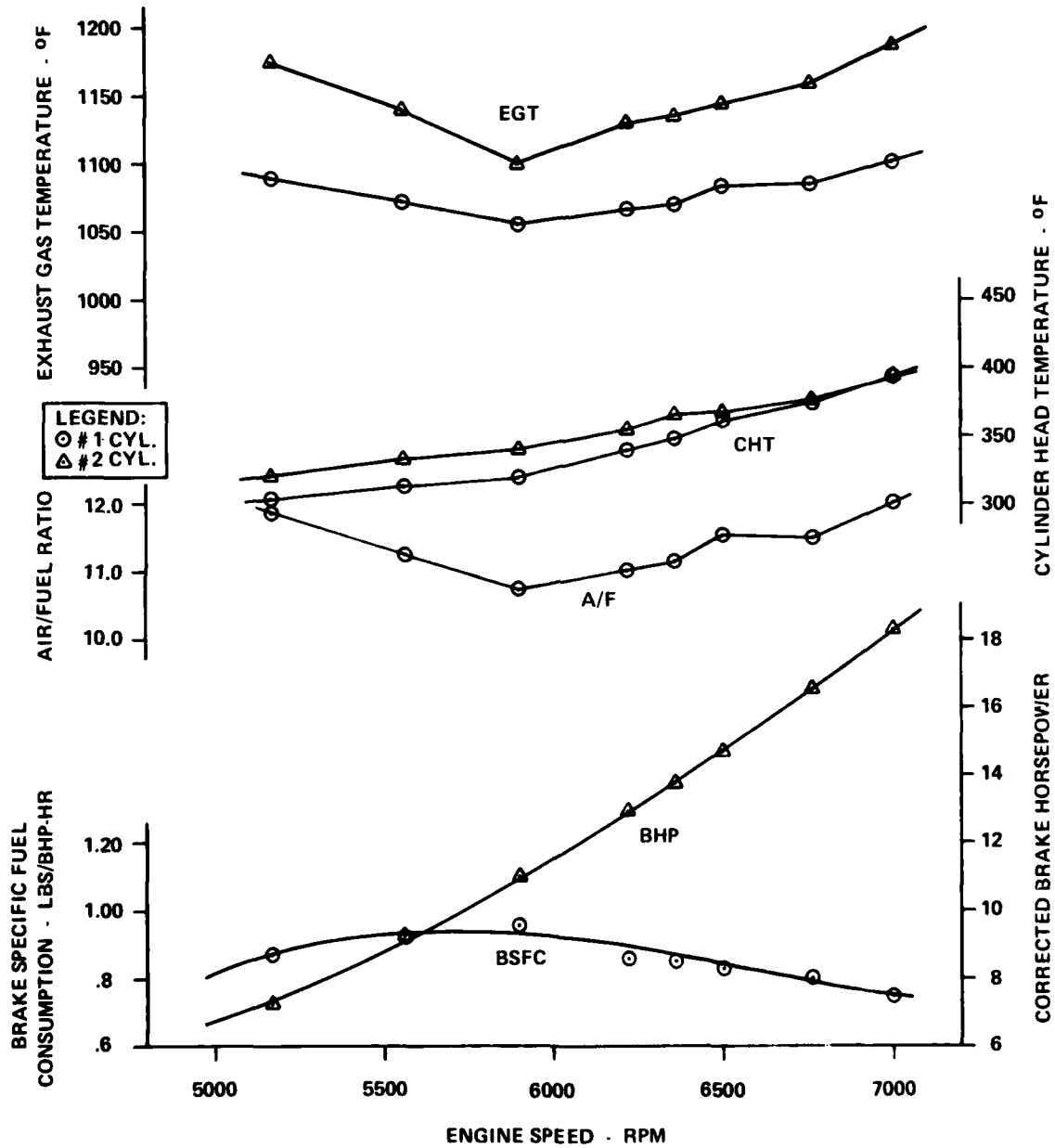


FIGURE 23. SECOND-GENERATION ENGINE PROP LOAD CURVE.

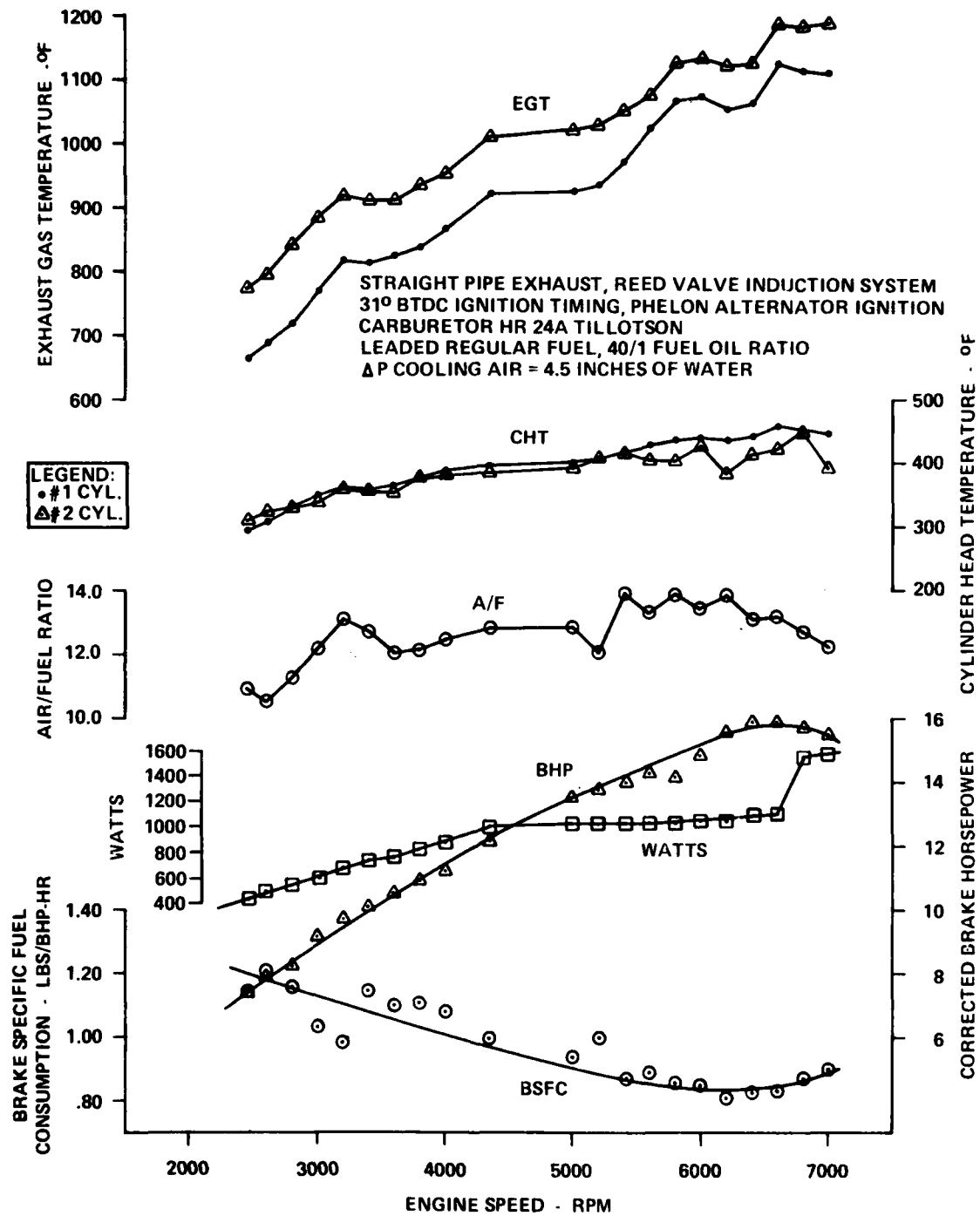


FIGURE 24. SECOND-GENERATION ENGINE FULL THROTTLE CURVE.

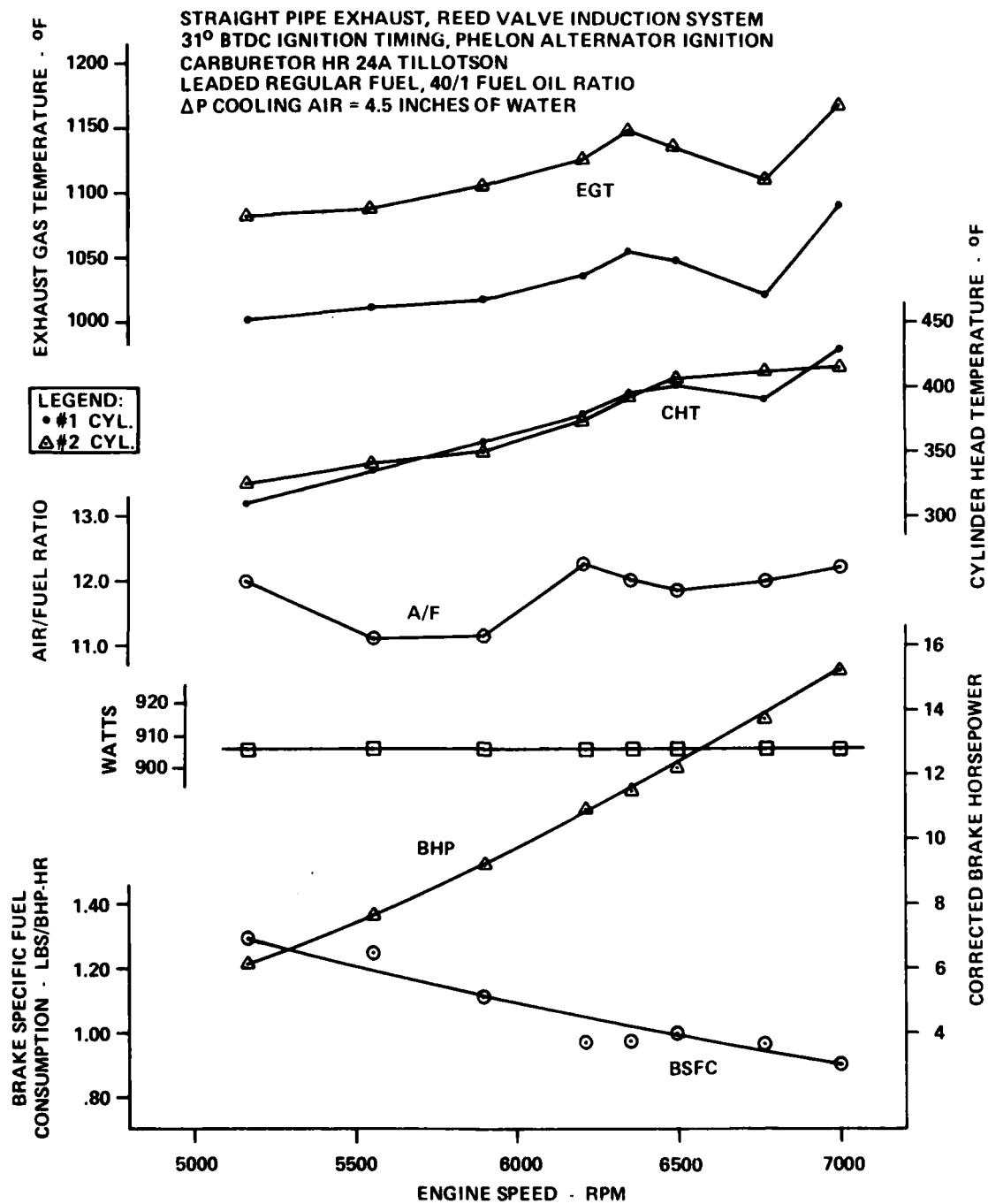


FIGURE 25. SECOND-GENERATION PROP LOAD CURVE.

## ENDURANCE STAND TESTING

The second-generation engine with propeller, as shown in Figure 26 was mounted on the TCM endurance test stand for durability evaluation under the previously described duty cycle. Results from the second 150-hour endurance run are presented in the following synopsis:

- Failures causing temporary engine shutdown:
  - (1) At 79.50 Hours - Crankshaft Failure. Due to a crack propagating from a stress concentration area at the crankshaft keyway where the alternator ignition rotor was installed. This failure necessitated replacement of the crankshaft and all associated bearings. The Phelon alternator was also damaged and had to be replaced.
  - (2) At 99.37 Hours - #2 Piston Seizure. Caused by maladjustment of the carburetor resulting in excessively lean mixture, this resulted in loss of the complete cylinder assembly. Disassembly revealed that #2 connecting rod crankpin bearing cage was broken also.
  - (3) At 120.09 Hours - #2 Connecting Rod Bearing Failure. Resulted in loss of crankshaft and #2 connecting rod.
- Parts which survived the full 150-hour endurance test were:

(1) Crankcase	(6) #1 Piston Pin Bearing
(2) #1 Connecting Rod	(7) #1 Piston Rings
(3) #1 Cylinder	(8) Complete Reed Cage Assembly
(4) #1 Piston	(9) Carburetor
(5) #1 Piston Pin	(10) Intake Manifold
- Maintenance and repair record for the engine during the endurance testing was as follows:

(0 hours of operation) All parts new except the crankcase, which had 172.48 hours prior running time.

(52.13 hours of operation) Scheduled engine shutdown to clean pistons and rings because of previous carbon stickage experience. Parts replaced:

  - (1) One ring broken in removal for cleaning.
  - (2) Cylinder gasket #2 position.

(55.05 hours of operation) Fluid leak under #2 gasket spotted during inspection. Cylinder removed, torn gasket replaced.

Decision was also made at this time to remove surface gap spark plugs (and install Champion RMJ-3 conventional electrode plugs) due to low voltage output of Phelon ignition system.



#### ENGINE CHARACTERISTICS

DISPLACEMENT	16.7 CU. IN. (274 CC)
POWER	18.4 HORSEPOWER - 900 WATT ALT = 16.9 BHP @ PROP SHAFT
WEIGHT	26 LBS. INCLUDING THE 10.5 LB. ALTERNATOR
BSFC	.74 LB/BHP @ 7000 RPM
DIMENSIONS	12.5/8" L X 19.25" W X 9.5" H
INDUCTION SYSTEM	REED VALVE
EXHAUST SYSTEM	OPEN PORT

FIGURE 26. MK II REED CAGE INDUCTION CONFIGURATION.

(79.50 hours of operation) Crankshaft breakage at ignition rotor keyway. Also #2 rod bearing was found to be broken. Parts replaced:

- (1) Crankshaft
- (2) Both connecting rod bearings
- (3) Both oil seals
- (4) All main bearings
- (5) Cylinder gaskets
- (6) Crankcase gasket
- (7) Alternator and rotor

(99.37 hours of operation) Number 2 piston seizure, during teardown #2 connecting rod bearing was also found to be broken. Parts replaced:

- (1) #2 Piston and cylinder assembly
- (2) #2 Connecting rod bearing
- (3) Cylinder gasket

The #1 piston and cylinder assembly was pulled for inspection; the rings had to be freed due to carbon stickage.

(120.09 hours of operation) Number 2 connecting rod bearing failure. Parts replaced:

- (1) #2 Connecting rod bearing
- (2) #2 Piston (not a failure, it was broken during build-up)
- (3) #2 Ring
- (4) Both thrust bearing assemblies
- (5) Crankshaft
- (6) #2 Connecting rod
- (7) Both oil seals
- (8) #1 Connecting rod bearing (precautionary, not an actual failure.)

● Major problem areas were thus identified as follows:

- (1) #2 Crankpin bearing failure
- (2) Ring stickage due to carbon deposits

The completion of this 150-hour endurance test satisfied the requirements for endurance testing of the MK II engine, however, since evidence indicated that both of the major problem areas might be chargeable to the lubricant, additional endurance tests were conducted.

The oil that is premixed with the fuel for internal lubrication of bearings and cylinder wall surfaces has a profound influence on maintenance requirements, reliability, durability and the suitability of standard production rings, pistons, cylinders and connecting rod and other bearings.

In the first- and second-generation engines a mineral two-stroke engine oil was used, and was initially premixed with a fuel to oil ratio of 20:1. This oil is intended for use in systems with load modulated oil metering pumps which normally deliver a much leaner oil to fuel ratio.

Endurance tests conducted at ratios of 30:1 and 40:1 fuel to oil yielded extended intervals of running so that 50-60 hours of tests could be conducted before removal and cleaning of the ring was required. However, at the ratio of 40:1 fuel to oil the problem became apparent with the crankpin bearing cage and after about 40-60 hours failure would occur.

Propeller cell tests indicated that cage life could be extended to 50-100 hours with better lubrication obtained by addition of the oil hole in the rod, but that the largest differences in bearing cage life were still related to the heat treatment of the cage.

The desire to use standard parts in spite of their production variations, and to extend the operating time between required cleaning of piston ring grooves, prompted the investigation of a synthetic lubricant for two-stroke engines. Premixed with a fuel to oil ratio of 40:1, this oil greatly reduced the carbon deposits formed in the spark plug and on the piston and has alleviated the piston ring sticking problems. The superior lubricating properties appear to provide for survival even of the split cage in the crankpin bearing assembly.

### THIRD-GENERATION ENGINE DESIGN

The initial RPV engine objectives and subsequent inputs were reviewed with respect to experience gained during the MK II development program to define a third-generation engine that would satisfy the final hardware delivery requirements of the contract. This design was to be suitable for further RPV application evaluation purposes, possibly including actual installation and flight testing. As a result, the contract was modified to design, fabricate and install as an integral part of the engine package an exhaust system and identify the resultant noise reduction.

#### EXHAUST SYSTEM

For loop scavenged two-stroke cycle engines of this type it is conceivable to use many different forms of exhaust systems. Each type has its own intrinsic advantages and disadvantages, as discussed in Appendix B, and each can effect the overall performance of the engine.

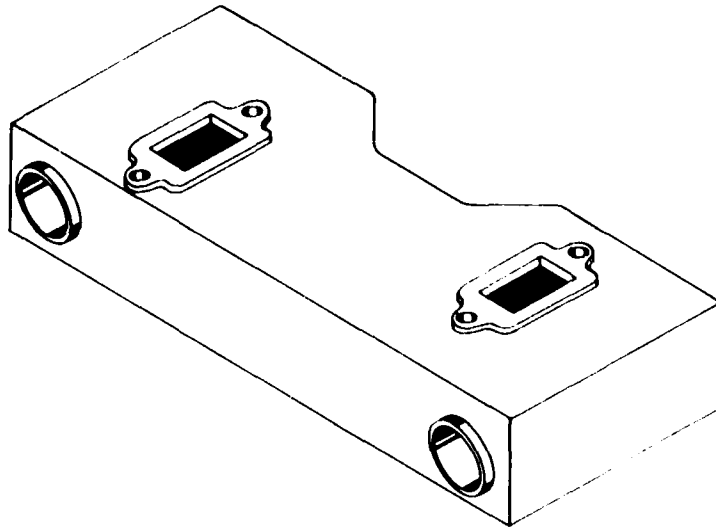
With consideration of the expected installation limitations, it was decided that the appropriate muffler envelope would be a box-shaped structure that would extend nearly the width of the cylinders and be located directly below them. The muffler would be connected to and suspended by the two standard cylinder exhaust flange attachments. The enclosed volume would encompass as much of the available space as conveniently available, but with avoidance of extensive flat surfaces that might resonate to radiate excessive mechanical noise and/or fracture as a result of bending fatigue. The dimensions of the final outlet to the atmosphere would be tailored to impose only the minimum impedance that could be justified by the overall noise level and the effect on performance.

Figure 27 shows the single chamber muffler design. The muffler was designed such that an additional separate chamber could be welded to the rear plate. The effect of an intermediate flow restriction could therefore be investigated.

#### INDUCTION SYSTEM

A review of the reed valve system development showed that while some improvement in performance had been accomplished, the desired objective of raising the peaking speed above 7000 rpm was not attainable due to the limitations of available valve flow area. Also, during the full course of the reed valve development the peak power values had only sporadically exceeded that demonstrated in the initial limited testing of the piston ported induction system. The piston ported system, with a single carburetor and branch manifold, was thus reincorporated in the new design.

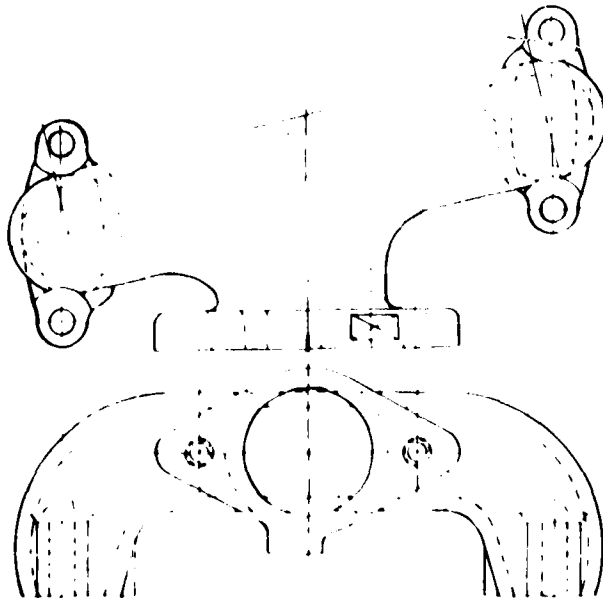




**FIGURE 27. MK II MUFFLER.**

With the obstruction on the top of the crankcase (constituted by the provisions for the reed valve assembly) removed, a shorter, more effective branch manifold could be installed. This would also be accompanied by a very desirable reduction in installation height of approximately 1.5 inches and some savings in weight.

The new manifold was designed to be made from an aluminum alloy casting and is shown in Figure 28.



**FIGURE 28. THIRD-GENERATION PISTON PORTED INDUCTION SYSTEM.**

## CRANKCASE

The crankcase casting was modified to:

- Integrate the reinforcement (that had been temporarily provided by the heavy steel flanged bushing) of the main bearing boss and improve the support of the alternator stator, so that deflections would be reduced and contact of the rotor and stator prevented.
- Eliminate the provisions on top of the crankcase for the reed inlet valve induction system.
- Effect a modest weight saving, but still retain quite conservative structural margins.

Genealogy of the MK II crankcase is shown in overall view in Figure 29 and in sectional detail in Figure 30.

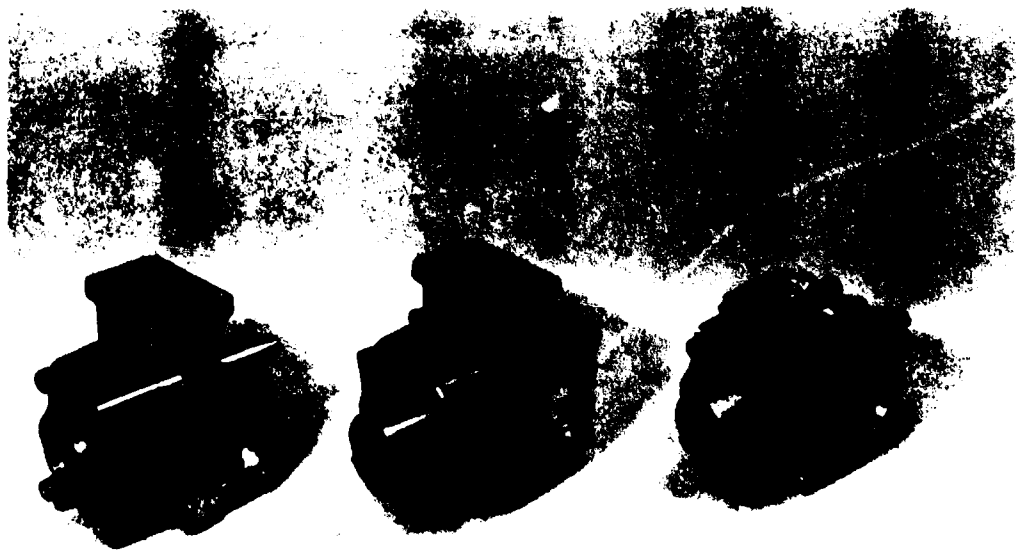


FIGURE 29. MK II FIRST SECOND THIRD GENERATION CRANKCASES.

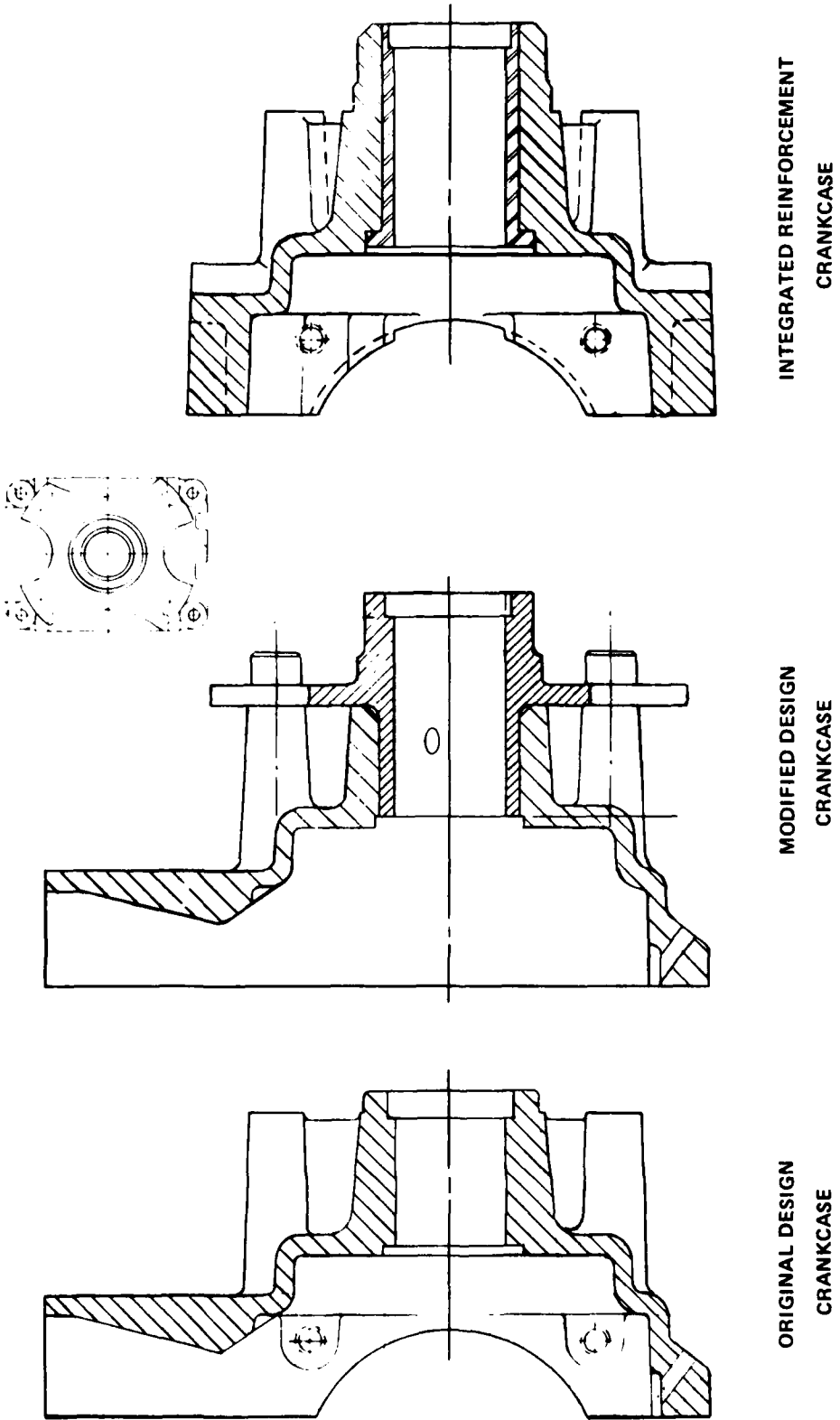


FIGURE 30. MK II CRANKCASE BEARING SUPPORT CHANGES.

## CRANKSHAFT

Changes in the crankshaft design were minor, and included:

- Reduction in taper angle to conform to an SAE standard for marine propellers and to provide better attachment for the alternator rotor and the propeller.
- Increase in thread size for better compatibility with the revised taper.
- A full circle center web for increased stiffness.
- Weight reduction in outer cheeks (any weight reduction on the crankpin side could be matched by a removal of counterweight).

TCM MK II crankshaft development is depicted in Figures 31 and 32.

## CONNECTING ROD AND BEARINGS

The connecting rod was modified by the addition of an oil hole as shown in Figure 33 to improve the oil mist lubrication of the bearing rollers. In addition, the big-end bore was slightly enlarged to accept a full complement of rollers.

The longer wristpin bearing assembly shown in Figure 34 was used to eliminate eccentric loadings that might result from the shorter bearing drifting to one side of the space provided between the opposing bosses in the piston.

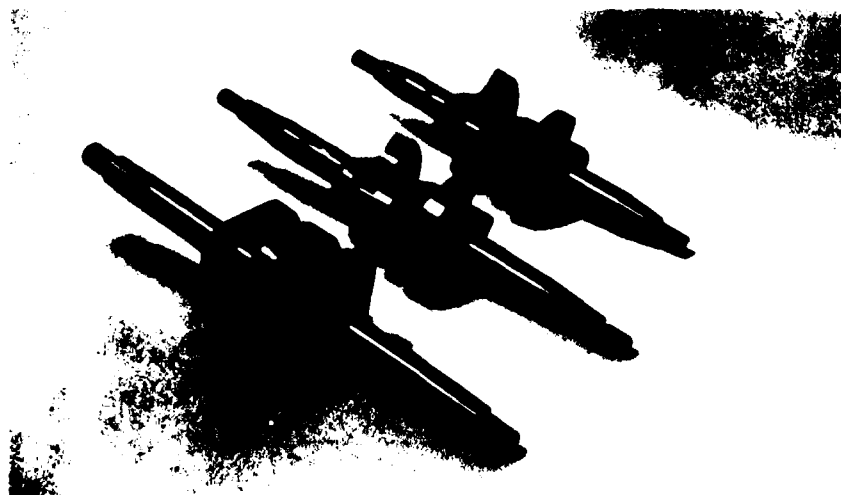
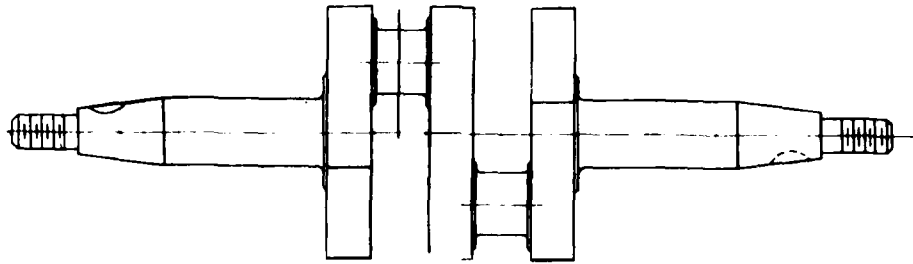
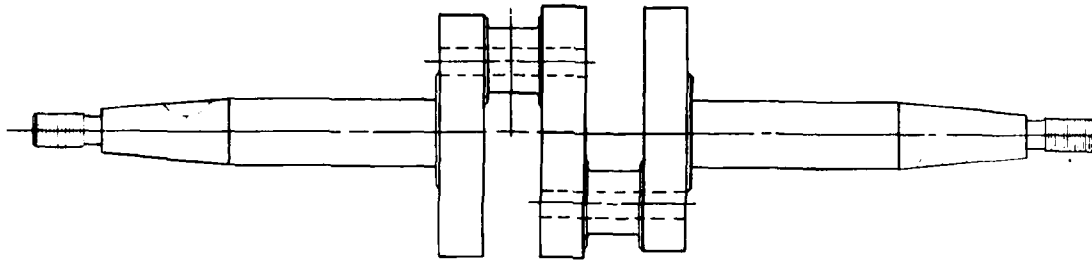


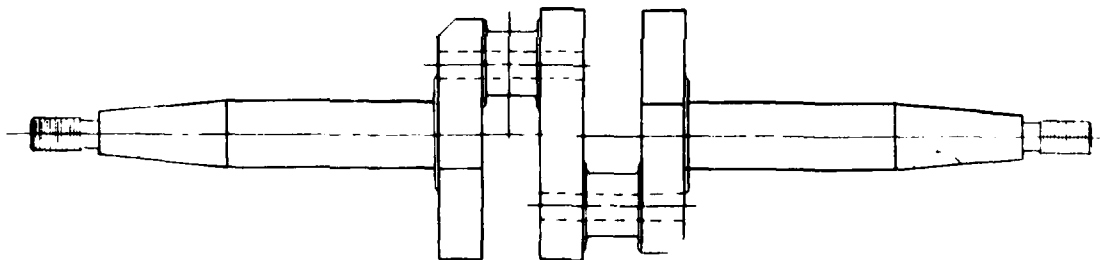
FIGURE 31. FIRST-SECOND-THIRD-GENERATION CRANKSHAFTS.



#1



#2

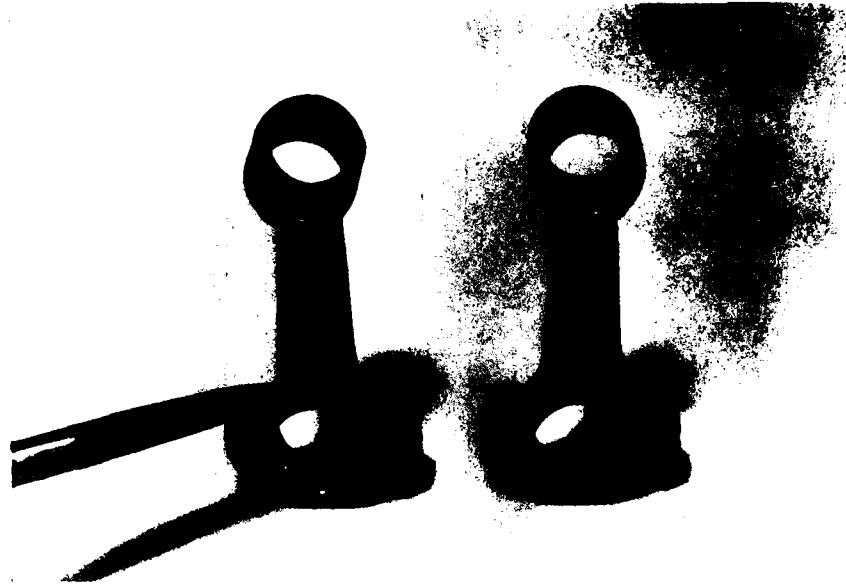


#3

**BASIC MODIFICATIONS**

- # 1 ORIGINAL DESIGN – 14° TAPER ON MAIN SHAFT
- # 2 EXTENDED MAIN SHAFT FOR ADDITION OF ALTERNATOR – CHANGE TO 10° TAPER
- # 3 EXTENDED MAIN SHAFT FOR ADDITION OF ALTERNATOR –  
 ADDED FULL CIRCLE CENTER WEB  
 CHANGED TO 3° 34' 47" TAPER – THIS IS AN SAE STANDARD TAPER  
 THREAD SIZE CHANGE FROM .375 - 24 UNF TO .500 - 200 UNF

FIGURE 32. MK II CRANKSHAFT DESIGN CHANGES.



- MODIFIED - OIL HOLE ADDED
- ORIGINAL CONNECTING ROD

FIGURE 33. CONNECTING ROD DESIGN CHANGES.



LONG AND SHORT WIDTH WRIST PIN BEARINGS

FIGURE 34. WRIST PIN DESIGN CHANGES.

Because of the endurance testing experience with the second-generation engine, the split-cage type of crankpin bearing was still considered too much of a threat to reliability (if not to durability) in this high speed application. As a consequence, the split-cage (with its sensitivity to rapid wear and fatigue) was eliminated in the third generation design. The connecting rod crankpin bore was slightly enlarged to accept the full complement of rollers illustrated in Figure 35.

#### ALTERNATOR-IGNITION SYSTEM

The combined capacitor discharge ignition system (with its trigger pickup control and high tension circuitry), alternator stator assembly, and electrical power conditioning components were repackaged as shown in Figure 36 for incorporation in the third generation MK II engine. Repositioning of some of the components permitted their incorporation in a lighter and smaller case with less interference to engine cooling airflow.

#### LUBRICANT

Based on the successful use of a synthetic lubricant in the second-generation engine, the combination of the cageless full complement of rollers and the synthetic lubricant should result in a significant reliability margin.

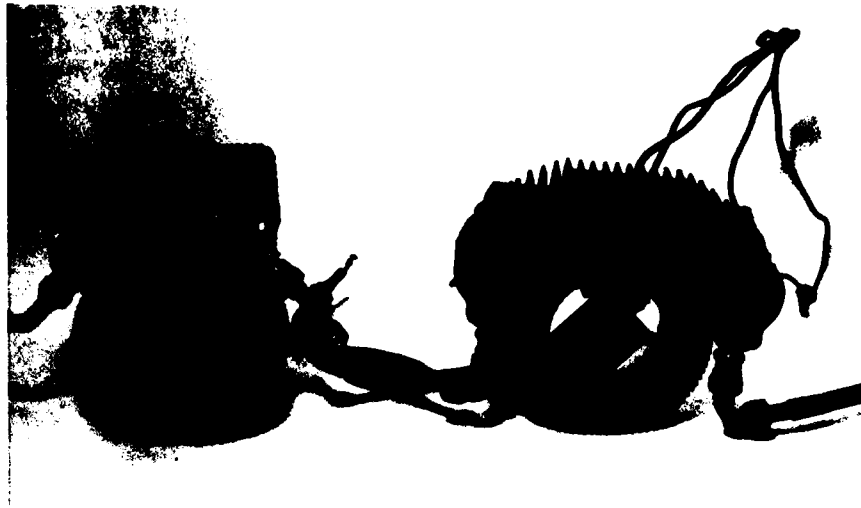
#### ENGINE ASSEMBLY

The third generation MK II engine, with propeller and muffler installed, is illustrated in Figure 37 along with a brief listing of its specifications. Three views of the assembly showing the arrangement of various components and accessories and overall dimensions are shown in Figure 38. Gaskets, fasteners, bearings, seals and all standard and special components are shown in Figure 39 in a manner intended to depict their integration into the complete assembly.



SPLIT BEARING CAGE AND FULL ROLLER COMPLEMENT

FIGURE 35. CRANKPIN BEARING COMPARISON.



NEW STYLE  
PHELON ALTERNATOR

OLD STYLE  
PHELON ALTERNATOR

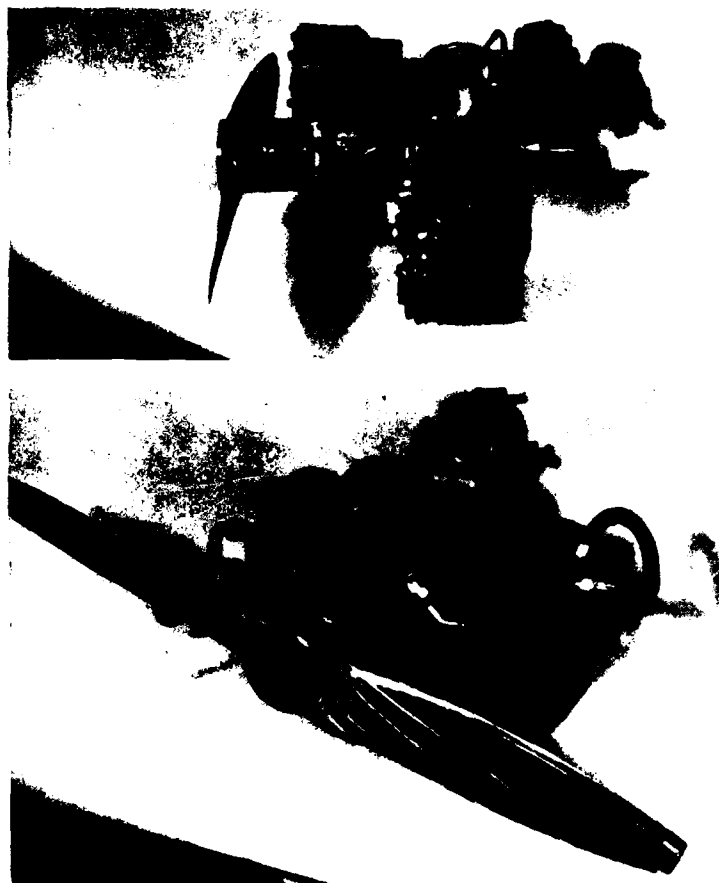
FRONT VIEW



SIDE VIEW

FIGURE 36. FIRST-AND SECOND-GENERATION ALTERNATOR DESIGN.





<b>DISPLACEMENT</b>	<b>16.7 CU. IN. (274 CC)</b>
<b>POWER</b>	<b>18.7 HORSEPOWER (ALTERNATOR UNLOADED)</b>
<b>ALTERNATOR OUTPUT</b>	<b>- 900 WATT ALT. = 17.1 BHP @ PROP SHAFT</b>
<b>MUFFLER</b>	<b>- 4% MUFFLER LOSS = 16.4 BHP @ PROP SHAFT</b>
<b>WEIGHT</b>	<b>26.2 LBS. (INCLUDING THE 10.5 LB. ALTERNATOR, IGNITION &amp; PCU SYSTEM)</b>
<b>BSFC</b>	<b>.79 LB/BHP @ 7000 RPM</b>
<b>DIMENSION</b>	<b>12.5/8" L X 19.25" W X 8" H</b>
<b>EXPECTED ENGINE LIFE</b>	<b>150 HOURS</b>
<b>INDUCTION SYSTEM</b>	<b>PISTON PORTED</b>
<b>MUFFLER (OPTIONAL)</b>	<b>EXHAUST BOX</b>

**FIGURE 37. THIRD-GENERATION MK II SPECIFICATIONS.**

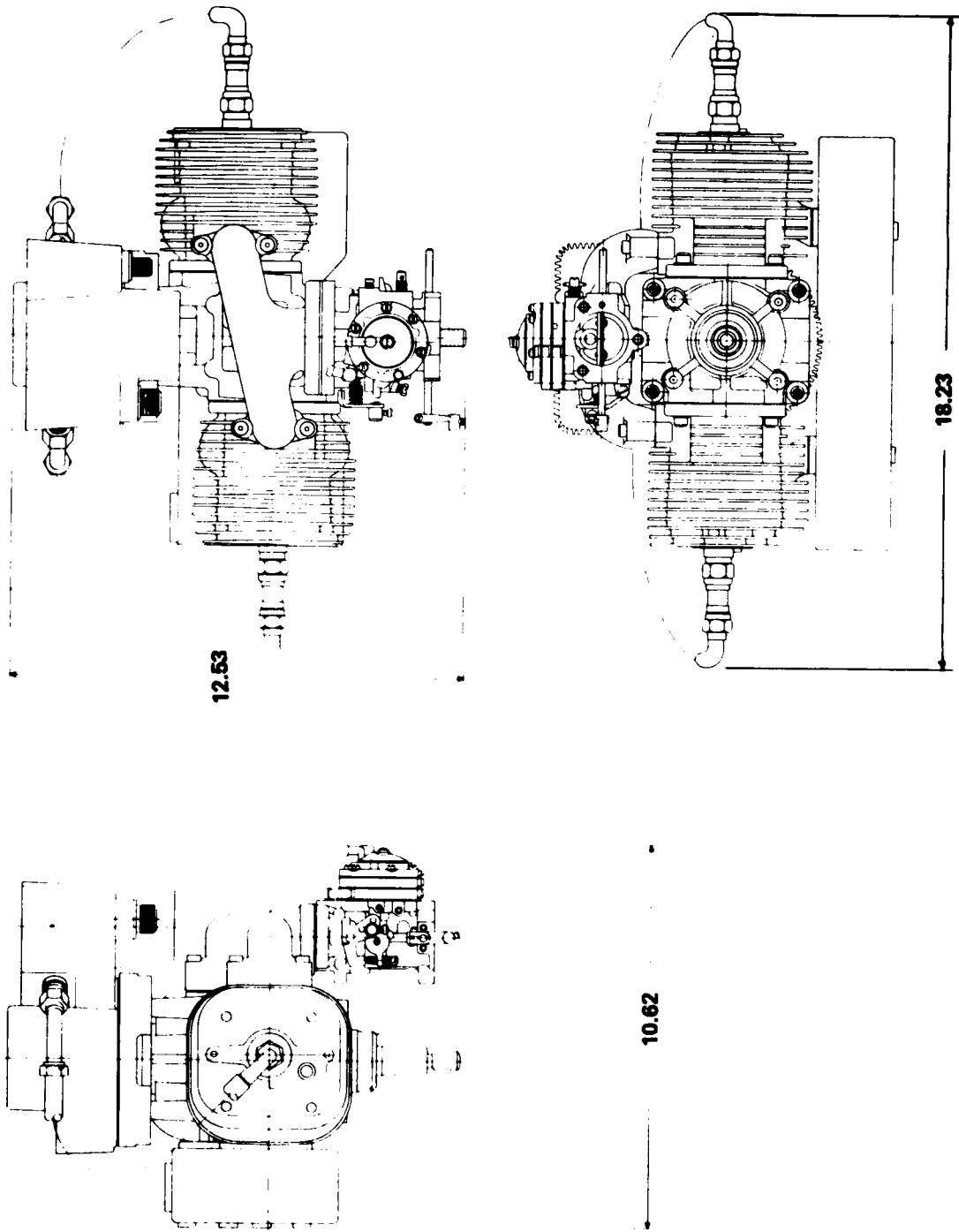


FIGURE 38. THIRD-GENERATION MK II OUTLINE DRAWING.



FIGURE 39. THIRD-GENERATION MK II ENGINE DETAILS.

## THIRD-GENERATION ENGINE TESTING

### DYNAMOMETER STAND TESTING

The power and fuel consumption of the third-generation configuration of the MK II engine was evaluated on the dynamometer without the muffler installed. This permitted direct comparison of the new piston ported induction system with the reed valve induction that had been investigated in previous developmental configurations.

Figures 40 and 41 present full throttle and propeller load results, respectively, showing power, specific fuel consumption and operating temperatures for the speed range from 5000 to 7000 rpm. These data correspond to the engine with the ignition/alternator unit installed but with no electrical load.

Unfortunately, instrumentation difficulties prevented the acquisition of reliable induction airflow data. Air-fuel ratio could thus not be directly calculated, but it is inferred from the operating techniques and the moderate BSFC and EGT data that it was never below a value of about 12:1 and excess fuel was not required for internal cooling.

The data for Figure 40 was acquired with the carburetor fuel jet adjusted, at each speed point, for maximum best power. Additional fuel would be used, if necessary, to prevent the exhaust gas temperature from exceeding a limit value of 1200° F. The low values of BSFC and EGT imply that a comfortable cooling margin is provided by the external cooling air, and represent the engine's temperance as influenced by the dynamometer operator's ability to adjust fuel flow to the minimum side of a broad torque peak.

Maximum power produced was 18.7 BHP with a corresponding 0.78 BSFC, which compares to the reed valve configuration of 18.4 BHP and 0.74 BSFC.

Figure 41 shows engine operation when throttled along a cubic power curve from a WOT point at 7000 rpm. The carburetor jet adjustment remained, throughout the run, at the setting required for maximum best power at the 7000 rpm WOT point.

The influence of external air cooling on safe engine operating limits had not been adequately established, but the safe margin of exhaust gas temperature indicated in Figure 41 implies that the specific fuel consumption could have been reduced to even lower values by mixture leaning. In this respect, however, it should be noted that because of the nature of the scavenging process, fuel economy in a two-stroke engine with carburetor will respond better to throttling than to leaning. Minimum BSFC would thus be expected at somewhat richer mixtures than with conventional four-stroke cycle operation.

STRAIGHT PIPE EXHAUST, Y MANIFOLD INDUCTION SYSTEM, 31° BTDC IGNITION TIMING  
 PHELON ALTERNATOR IGNITION SYSTEM, CARBURETOR HR43A TILLOTSON  
 LEADED REGULAR FUEL, 40/1 FUEL/OIL RATIO, SYNTHETIC OIL  
 ΔP COOLING AIR = 4.5 INCHES OF WATER

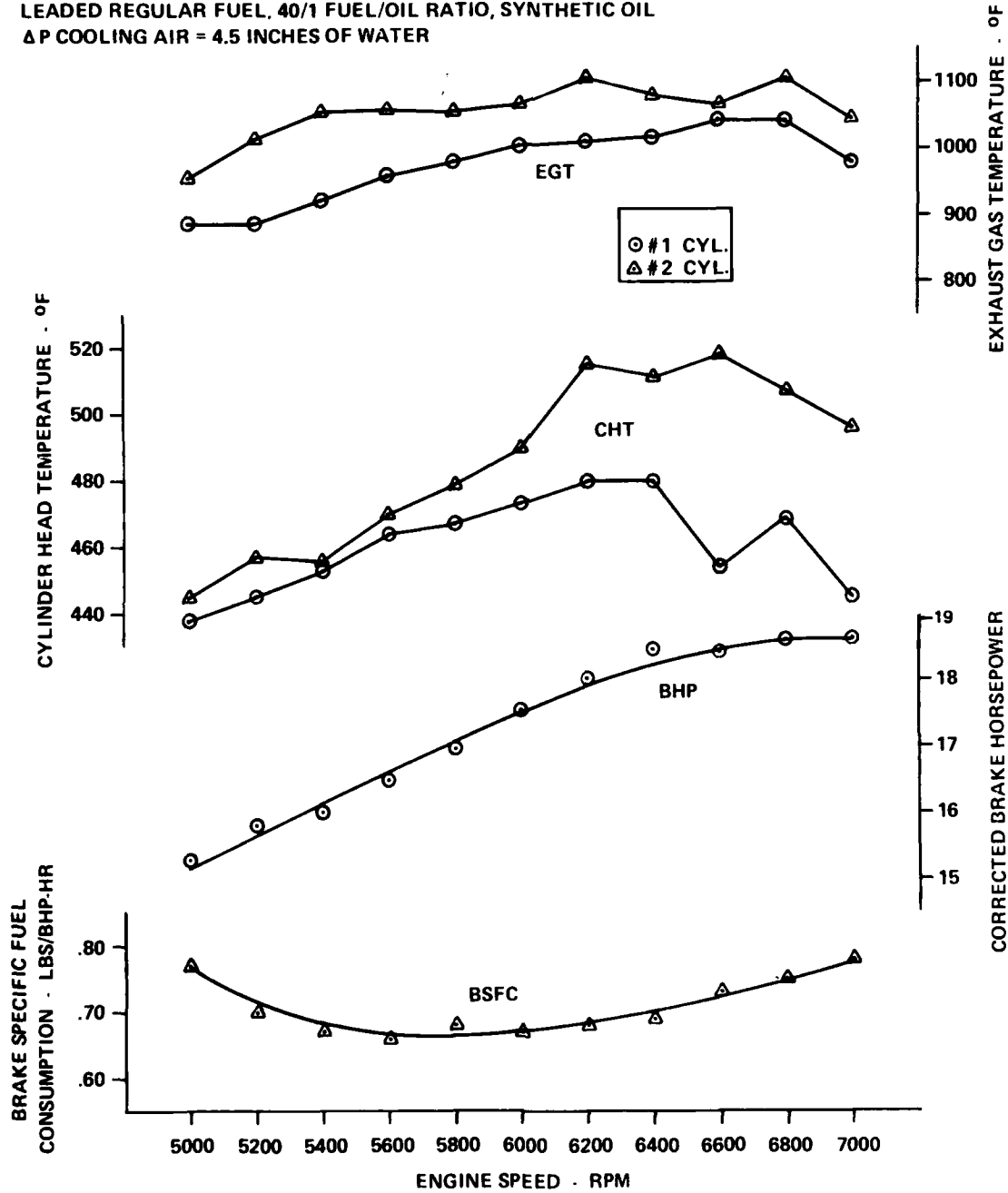


FIGURE 40. THIRD-GENERATION ENGINE FULL THROTTLE CURVE.

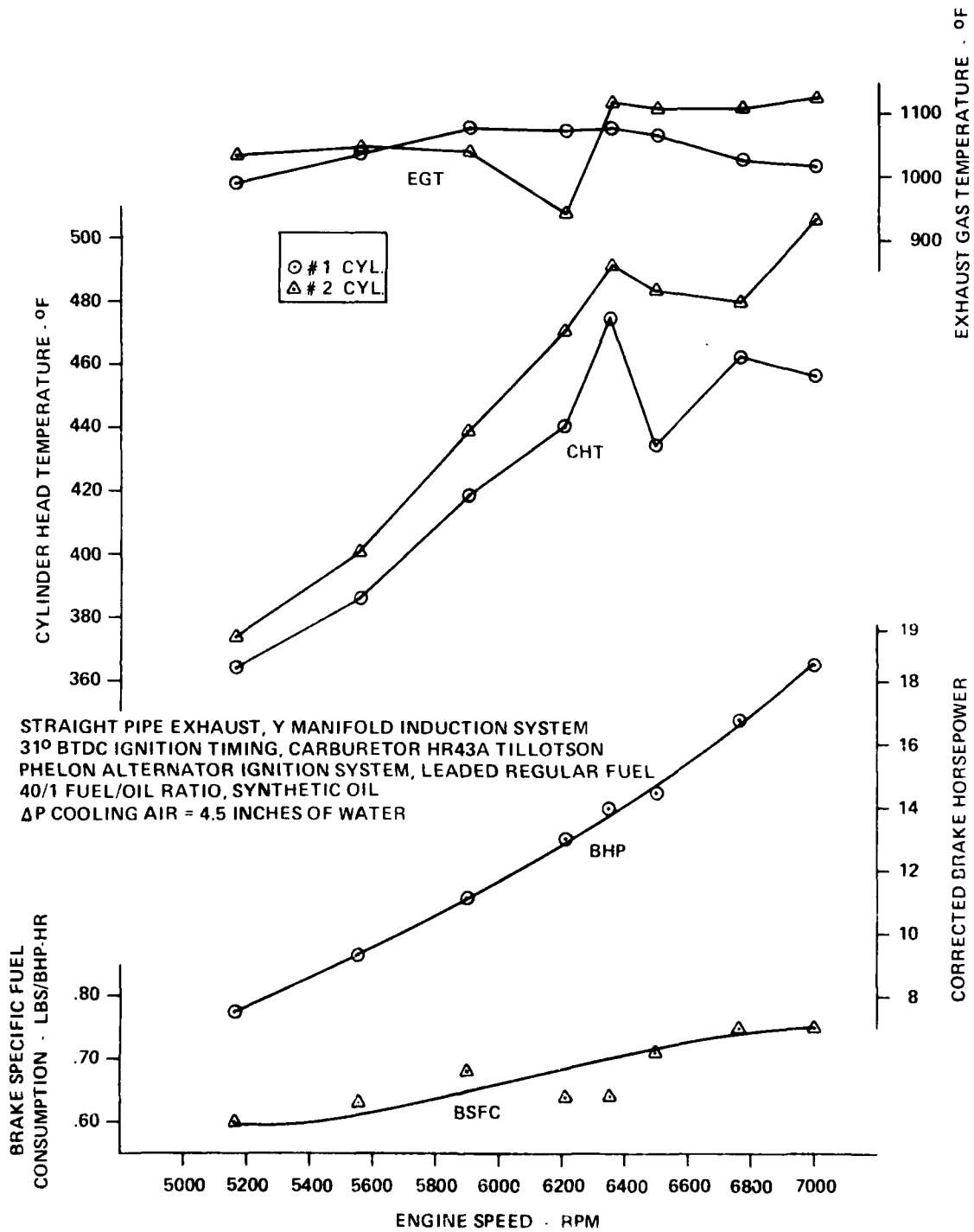


FIGURE 41. THIRD-GENERATION ENGINE PROP LOAD CURVE.

### PROPELLER STAND TESTING

The propeller test stand was used to calibrate the MK II engine and exhaust system since dynamometer running was negated due to inadequate space available under the engine to mount the exhaust system. As a result, power data was obtained by prorating engine speed measurements using the standard propeller cubic speed formula, or in equation form;

$$\% \text{ Power Change} = \left[ 1. - \left( \frac{\text{RPM}_2}{\text{RPM}_1} \right)^3 \right] * 100.$$

where,  $\text{RPM}_2$  = full throttle speed of engine with exhaust system  
and  $\text{RPM}_1$  = full throttle speed of engine with bare exhaust ports.

Tested bare, the engine achieved a full throttle speed of 7129 rpm. With the first chamber (as shown in Figure 27) of the total muffler bolted in place the full throttle speed fell to 7030 rpm, resulting in a 4.1% power loss for the system. This was sufficiently close to the design value that it was decided not to modify the first chamber of the muffler.

A duplicate first chamber was attached to a special designed second chamber by an airtight seam weld to form a complete (two-chamber) muffler. The two-chamber muffler was then bolted in place and the engine achieved a full throttle speed of 6821 rpm, equivalent to a 12.4% power loss.

This was considered excessive and inspection of the second chamber revealed that the ends of the two outlet tubes inside the box were in too close proximity to one of the outside walls and might be providing the excessive reaction evidenced by the fall in full throttle engine speed. The tubes were cut out of the box, 1 inch was cut from their internal length, and they were rewelded back into the box. This was not completed until the following day and hence the baseline had to be reestablished. With the engine bare the full throttle engine speed was 7090 rpm. With the complete muffler in place the engine speed became 6874 rpm to give a power loss of 8.9%.

This was considered close enough to the design value that no further power development was undertaken.

### EXHAUST NOISE TESTING

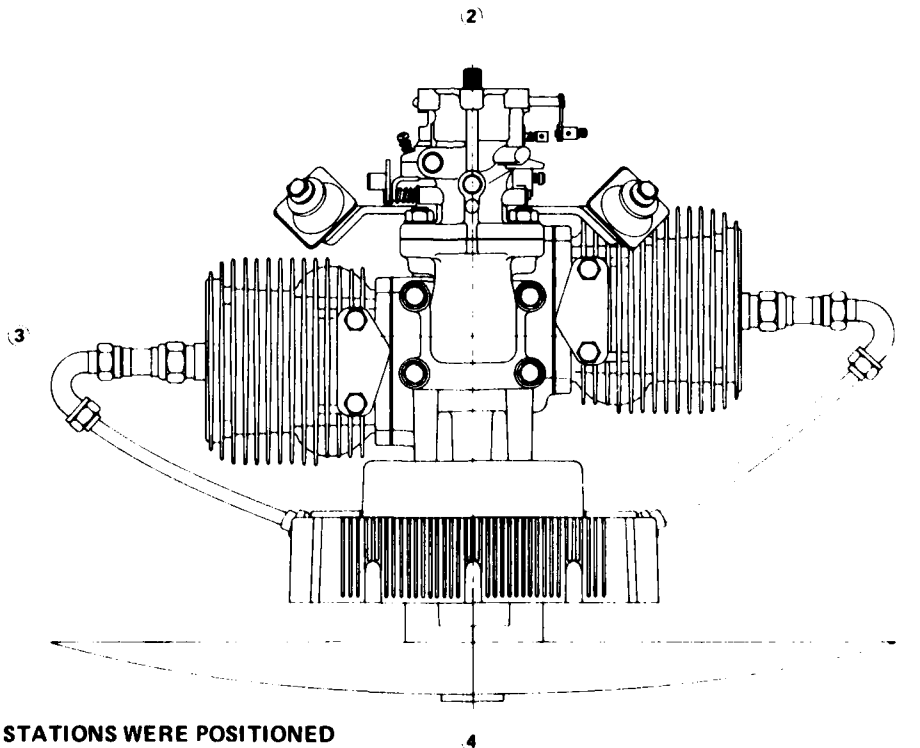
The engine was mounted on a self-contained portable propeller test stand and taken to a large open grass covered area on the TCM complex. Ambient noise readings were less than 7 dba. Sound measurements using the dba and dbc weighing scales were taken at four stations around the engine, each 25 feet from the center of

the engine, as shown in Figure 42. Microphones were positioned approximately 3 feet above ground level. Sound measurements were taken at four engine speeds: 4000, 5000, 6000 and full throttle.

Four exhaust configurations were tested -

- (1) Open exhaust - "bare"
- (2) First muffler volume only (single chamber muffler)
- (3) Complete muffler (two chamber muffler)
- (4) Remote exhaust

In the remote exhaust configuration, two exhaust ducts were attached to the engine cylinders and led off toward station (2), the position of which is shown in Figure 42, their outlets being situated approximately 2 feet inside station (2) on the engine centerline. In this configuration the exhaust noise was essentially inaudible at stations (1), (3) and (4) and for the purposes of calculation it was assumed that with the engine in this configuration the exhaust noise was not a contributor to the overall noise measured at stations (1), (3) and (4).



**NOTE:**  
SOUND STATIONS WERE POSITIONED  
25 FEET FROM THE CENTER OF THE  
ENGINE.

**FIGURE 42. NOISE MEASUREMENT LOCATIONS.**



The exhaust data taken in the field is shown in Table 4; this data is shown modified by subtraction to yield the exhaust noise levels in Table 5 in relation to the power loss evidenced by the various systems. For two of the four exhaust configurations the full throttle exhaust noise levels were proportioned to yield values at 7000 rpm so that subtraction of the various sound levels could realistically take place.

For an operational RPV the only two real engine speeds of interest are full throttle and loiter and in this case correspond to 7000 and 4000 rpm. From the calculated exhaust noise levels obtained at stations (1), (3) and (4) for these two engine speeds there would appear to be virtually no noise advantage to using the complete exhaust muffler as opposed to only the first exhaust box. In addition, the exhaust noise levels for both the complete exhaust system and the first exhaust box are at least 2 db less than the combined total of the propeller, intake, and mechanical noise levels (the propeller, intake and mechanical noise levels combine to give the remote "D" noise levels shown in the table).

As a consequence there is little to be gained in attempting to further reduce the exhaust noise levels as a means of reducing the total noise level of the complete propulsion system. Any further noise reduction effort should be aimed at the propeller noise, the intake noise and the mechanical noise.

By their very nature, sound levels measured in a free field environment using a hand-held meter are only accurate to within + 1 db; even in an acoustic chamber under ideal conditions it is difficult to improve on + 1/2 db. With this in mind, together with the highly directional nature of the exhaust noise and propeller noise, the measured nonuniform nature of the sound field around the engine is not really too remarkable.

In addition, there is little doubt that if the engine had been tested with the exhaust above rather than below the engine the amount of reflection from both the stand and the ground would have been minimized and the numerical values indicated on the sound level meter also reduced. However, the calculated insertion losses of the various exhaust systems would almost certainly not have been significantly changed.

#### ENDURANCE STAND TESTING

Unfortunately, contract schedule and funding did not allow for an additional 150-hour endurance run, however, the third-generation engine was run with synthetic lubricant approximately 50 hours at the endurance duty cycle, with no problems occurring. The engine was disassembled and there was no evidence of piston ring sticking problems or crankpin bearing failure. Based on the condition of the engine parts the expected engine life can be estimated at 150 hours.

TABLE 4. MEASURED NOISE DATA.

1.		2.		3.		4.		KRPM	
DbA	DbC	DbA	DbC	DbA	DbC	DbA	DbC		
90.5	92.0			89.0	91.0	94.0	94.5	4	Remote Exhaust
96.0	97.0			93.5	95.0	100.0	100.0	5	
101.0	101.0			100.5	101.5	104.5	105.0	6	
106.0	106.5			106.0	106.5	107.5	108.0	7.0	
92.5	95.5	91.0	95.0	91.0	95.0	96.0	96.5	4	Complete Muffler (First and Second boxes)
97.0	100.0	94.0	97.0	96.0	98.0	101.0	101.5	5	
103.0	104.5	96.0	101.0	102.0	103.5	106.0	106.0	6	
106.0	106.5	98.0	103.5	106.0	107.0	108.0	108.0	6.8	
91.0	94.5	91.0	94.0	91.0	93.0	96.0	97.5	4	First Exhaust Box Only
96.5	98.0	94.0	97.0	94.5	96.0	101.5	102.0	5	
102.0	102.5	98.0	100.5	101.0	102.0	106.5	107.0	6	
107.0	107.5	102.0	105.0	107.5	108.0	108.5	109.0	7.0	
99.0	99.5	96.0	97.0	97.0	98.0	98.0	98.5	4	Open Exhaust (No Muffler)
101.0	101.5	99.0	100.0	100.5	101.0	102.5	103.0	5	
105.0	105.5	103.0	104.0	105.0	105.5	107.0	107.5	6	
109.0	110.0	107.0	108.0	110.0	111.0	111.0	111.5	7.1	

TABLE 5. CORRECTED NOISE DATA.

STATION	KRPM	TOTAL NOISE LEVELS				EXHAUST NOISE		
		COMPLETE A	FIRST BOX B	OPEN C	REMOTE D	COMPLETE A-D	FIRST BOX B-D	OPEN C-D
1	4	92.5	91.0	99.0	90.5	88.5	81.5	98.5
	5	97.0	96.5	101.0	96.0	90.0	87.0	99.5
	6	103.0	102.0	105.0	101.0	99.0	95.0	103.3
	7	106.75	107.0	108.6	106.0	99.0	100.0	105.4
		COMPLETE A	FIRST BOX B	OPEN C	REMOTE D	COMPLETE A-D	FIRST BOX B-D	OPEN C-D
3	4	91.0	91.0	97.0	89.0	87.0	87.0	96.5
	5	96.0	94.5	100.5	93.5	93.0	87.5	99.5
	6	102.0	101.	105.0	100.5	97.0	91.5	103.8
	7	107.0	107.5	109.5	106.0	100.0	102.5	107.3
		COMPLETE A	FIRST BOX B	OPEN C	REMOTE D	COMPLETE A-D	FIRST BOX B-D	OPEN C-D
4	4	96.0	96.0	98.0	94.0	92.0	92.0	96.0
	5	101.0	101.5	102.5	100.0	94.0	96.5	99.0
	6	106.0	106.5	107.0	104.5	101.0	102.5	103.5
	7	108.5	108.5	110.6	107.5	101.5	101.5	107.6

PERCENTAGE POWER LOSS	8.9	4.1	0.0
-----------------------	-----	-----	-----

## CONCLUSIONS

In general, the engine performance that was attained, the durability that was demonstrated, and the delivery of the TCM MK II engines substantially satisfied the objectives of the program. In addition, a 900-watt alternator with combined electrical power conditioning unit and engine ignition system has been successfully integrated into the engine assembly. Exhaust noise has been reduced with the installation of a simple muffler that is compatible with the installation. The muffler attenuates the exhaust noise to a value that is concealed by the propeller and mechanical noise level background, with a power degradation of 4 percent.

In particular, the following conclusions are presented:

- (1) The reed valve configuration tested could not surpass the piston ported induction system for maximum power.
- (2) A review of the reed inlet valve development indicates a lack of effective flow area past the open reeds.
- (3) Maximum power attained by the final configuration engine (third-generation engine) was 18.7 horsepower, with simple straight exhausts. The program goal of 20 horsepower was not demonstrated.
- (4) The demonstrator goal of 31 pounds for engine and alternator was substantially improved. The MK II engine and alternator weighed 26.2 pounds.
- (5) The combined alternator-ignition system met the design goals of 900 watts at 7.5 horsepower.
- (6) The fuel consumption goal of 0.8 lb/bhp-hr at maximum power was improved by the MK II engine. At peak power a 0.78 BSFC was demonstrated. At part throttle a BSFC of 0.60 was demonstrated.
- (7) A design life of 150 hours was not demonstrated. The reed valve engine could only be rated for 50-100 hours because of bearing cage life expectancy. For the final piston ported engine, with full complement rollers on the crankpin, the design life is estimated at 150 hours.
- (8) A simple single chamber exhaust box demonstrated the capability of suppressing the exhaust noise to a level where it would not be a significant contributor to the overall noise level of the RPV propulsion system, with an engine power penalty of 4 percent.

## RECOMMENDATIONS

- (1) During the course of this program, experimental development effort was concentrated on various system components and functions that could not easily be investigated by an analytical approach. To expedite such development, the crankcase and other structural items of more predictable nature were provided with ample strength margins. These should now be pared away to limits dictated only by performance, reliability and economic considerations for the whole RPV program.
- (2) Since exhaust gas temperature provided both an earlier and a more dependable warning of impending seizure of the piston in the cylinder than cylinder head temperature, it should be closely monitored during any development testing.
- (3) The following items related to piston seizure and the ability to operate at minimum BSFC need further investigation:
  - Influence of delivery ratio and speed on critical operating temperatures.
  - Relative influence of air cooling and fuel cooling on operating temperatures.
  - Influence of lubrication on survivable temperature.
  - Influence of unit loading on survivable temperature.
  - Thermal distortion of piston and cylinder and its reduction and/or compensation.
  - Most effective cooling fin configuration.
  - Exhaust port details and the possible use of an isolating liner to reduce heat transfer to the aluminum.

## APPENDIX A

### INDUCTION SYSTEM TYPES

For loop scavenged two-stroke cycle engines of this type it would be conceivable to use any of three different forms of induction system. Each type of induction system has its own intrinsic advantages and disadvantages, and each of these must be considered with due respect to this particular engine configuration and its application.

#### ROTARY VALVE

The first type of induction system which might be considered is the rotary valve, in either barrel or disc form. Both of these valve types have been used in high performance two-stroke engines to produce very high brake mean effective pressure (BMEP) values of over 130 lb/in<sup>2</sup>. For high performance (racing) applications it is an attractive type of induction system, since it allows the efficient transfer of the requisite amounts of fresh mixture into the crankcases over a relatively wide engine speed range. However, for an RPV engine, BMEP values of 130 lb/in<sup>2</sup> are neither required nor desired; hence, the high delivery ratio for this BMEP is not necessary.

The required BMEP for this cylinder in the MK II engine, for an output of 20 horsepower, is only slightly more than 60 lb/in<sup>2</sup> at 8000 rpm, and the delivery ratio necessary to allow the engine to develop this mean effective pressure should not be over 0.54. A rotary valve is not necessary in order to achieve this delivery ratio; either a reed or piston port type induction system has more than sufficient flow capability.

In addition to the cost and weight factors, the other chief disadvantage of a rotary valve is its complication of the engine configuration. Either type of rotary valve could be expected to add significantly to any reliability problems, due not only to the increase in the number of parts but also to the small clearances that must be maintained to ensure adequate sealing at the rotor to seat interface.

#### REED VALVE

A reed valve could be considered as a serious contender for this particular induction system requirement. It has few of the disadvantages of a rotary valve and appears to have several advantages in relation to the desired performance specification and other objectives.

Reed valves are used widely in several different industrial applications with a very high degree of reliability. Their airflow capabilities do not attain the high level of the rotary valve,

but this is not required for the modest BMEP required in the MK II engine for the specified output. Reed valves have been used successfully on engines with BMEP values as high as 120 lb/in<sup>2</sup>, and hence their flow capabilities far surpass that required for this engine.

In comparison to a piston port or third port type of induction system, a reed valve has three important basic advantages which may or may not prove to apply to both an RPV engine installation and application.

The first advantage is the shape of the full throttle torque curve. Because of the asymmetrical timing inherent with a reed valve, the full throttle power curve of a reed valve engine does not drop off so quickly at lower speed as a piston ported engine. For this reason reed valves are used extensively in the chain saw industry where good full throttle low speed torque is essential. In an RPV engine application, the torque requirement at low speed is set by the shape of the propeller load curve and the requisite engine acceleration characteristic from idle to maximum power. For a fixed pitch propeller the greater low speed torque of the reed valve is not required by the propeller characteristic, however, for a controllable pitch propeller the reed valve system offers an advantage. Because of the wider torque curve the reed valve offers the possibility of operating at a lower engine speed for a given power setting, thus creating a potential for noise reduction.

The second advantage is the flexibility permitted in valve placement on the engine. As a result, the carburetor and the remainder of the induction system can be arranged advantageously in relation to inlet flow and other engine considerations.

The third advantage is in regard to easier control of the spit-back of fuel out of the carburetor inlet. This is particularly a problem with piston timed induction systems when operating at low engine speed with wide open throttle. However, a propeller load precludes steady state operation in this part of the power envelope, and thus significantly reduces the advantage of the reed valve with respect to spit-back.

#### PISTON OR THIRD PORT INDUCTION

The piston port or third port induction system, which because of its simplicity is often used on two-stroke engines with relatively low specific power output, has also been successfully used at BMEP values in excess of 120 lb/in<sup>2</sup>. Consequently, there is no doubt of its potential capability of supplying sufficient fresh charge to allow the MK II engine to develop a BMEP of 60 lb/in<sup>2</sup>.

Piston port induction is the simplest and least expensive of

all three types, since no additional parts are required. Even though both the rotary and reed valves have been made quite reliable, they still cannot approach the inherent reliability of a piston port induction system devoid of added parts.

If high torque is not required over a wide speed range (such as is the case with a fixed pitch propeller load), the inherent inlet ramming capabilities of the inlet duct leading to the piston controlled port can be exploited to advantage. With proper design, the inertia of the inflow wave will bring the pressure in the crankcase well above ambient at the time of port closing and effectively supercharge the crankcase. While a very high delivery ratio is not required here, any margin of scavenging pressure can be used to help overcome the flow resistance of an effective muffler (if required) and, possibly, to reduce fuel consumption because of higher charge density during scavenging.

The main drawback encountered with an induction system of this type in many applications is that spit-back with attendant loss of fuel out the inlet will take place under wide open throttle (WOT) application at low engine speed.

If an inlet duct system that is designed for optimum ramming at high speed is operated with WOT at a lower speed, there will be time for the inflow to reverse and reduce the crankcase pressure again before the inlet port closes. In this situation, power output may actually be increased by partial closing of the throttle so that inflow velocity drops to zero just as the port closes. With a properly designed system on a propeller load, however, the throttle is closed much further to reduce the crankcase air inflow to lower power requirement. Because of the reduced crankcase pressure, there is little chance for a flow reversal thru the inlet port. The inflow wave, however, can still be reflected at the throttle and/or the closed port and produce a spit-back of fuel residing in the duct. If this is of consequence, it can be reduced by moving the carburetor jet downstream closer to the inlet port.

Another approach is to collect the spit-back fuel from one cycle and hold it until it can be sucked into the engine on the next induction stroke. The rejected mixture would not be lost into the atmosphere and would be used during the next intake stroke to produce useful work. The simplest method of achieving this is to use an open-cell, torpedo-style air filter which will both temporarily hold the fuel droplets and allow the filtered air to pass freely into the carburetor as it picks up the fuel on the next inflow cycle.

Using both of these design approaches, it is expected that the fuel loss over the whole operating range with propeller can be reduced to the point where any advantage of the reed valve in comparison to piston port induction is not of significant importance.



## APPENDIX B

### EXHAUST SYSTEM CONSIDERATIONS

When the exhaust port of a crankcase scavenged, two-stroke engine developing  $1.2 \text{ bhp/in}^3$  at 8000 rpm (or  $60 \text{ lbf/in}^2$  bmep) is opened by the piston the pressure in the cylinder will be approximately 3.0 atmospheres. During the blowdown of the burned gas through the exhaust port, the cylinder pressure will decay to about 2.0 atmospheres by the time the transfer ports are opened. At transfer opening the crankcase pressure will be approximately 1.4 atmospheres and therefore for some period (20-30 crankshaft degrees) cylinder gas will discharge into the transfer ducts and further pressurize the crankcase to a value of about 1.7 atmospheres. After this period of 20-30 crankshaft degrees, flow reversal in the transfer ducts will take place and first burned gas and then fresh gas will begin to flow out of the transfer ports and into the cylinder.

The amount of "blowback" into the transfer ducts, the period of this blowback, the extent of the flow reversal, the mass of fresh gas transferred into the cylinder, and the mass of fresh gas actually trapped in the cylinder at exhaust port closure will be determined to a very great extent by the pressure/time history present at the plane of the exhaust port by the exhaust system. In other words, this pressure/time history, which is completely dependent on the exhaust system, is a major controlling factor in the gas exchange process occurring inside the cylinder.

In a loop scavenged two-stroke engine of this type the exhaust port is physically open during the complete period of transfer of the fresh charge into the cylinder; hence the pressure/time history (or transient pressure) at the exhaust port has a profound effect on both the cylinder pressure and the transfer process. The main gas dynamic difference between two-stroke and four-stroke engines is in regard to their exhaust systems. For a four-stroke engine the exhaust system has only a relatively minor effect on performance, whereas in a two-stroke engine it has a major influence. As a result, the exhaust system of a two-stroke engine should always be designed as an integral component of the flow system, since the gas dynamic effects which it provides impact the performance of the power unit to a very considerable degree.

### CURRENT TWO-STROKE ENGINE EXHAUST SYSTEMS

For a loop scavenged engine, a high performance exhaust system should essentially perform two functions:

- (1) It should aid the scavenging process occurring inside the cylinder, pull all the burned gas out of the cylinder, and then entrain some of the fresh charge delivered to the cylinder out in

the exhaust pipe itself. By so doing, additional air would be supplied to the cylinder and the delivery ratio would increase accordingly.

(2) It would, by means of a correctly timed positive pressure wave traveling back up the exhaust pipe toward the cylinder, push most of the otherwise wasted short circuited fresh charge in the exhaust pipe, but as little as possible of the already burned gas back into the cylinder just before exhaust port closure and create, at exhaust port closure, a cylinder pressure considerably in excess of atmospheric pressure for a substantial increase in output combined with reduced fuel consumption. To a certain extent the engine/exhaust system combination could be looked upon as "supercharging" itself. Cylinder pressures at exhaust port closure as high as 1.8 atmospheres have been measured in high output engines.

The exhaust system which can provide all these desirable features is the so-called "tuned pipe", or more correctly, the two-stroke engine expansion chamber and is currently in wide use on motorcycles, snowmobiles and some outboard motors.

One often underestimated attribute of a good expansion chamber is the help it can provide in evacuating the cylinder of burned gas. Retention of burned gas in the cylinder leads to poor scavenging, charge dilution, high operating temperatures, pre-ignition, and in some cases, end gas detonation.

Because of any one of several reasons - cost and/or space limitations, torque curve shape, power output - full expansion chambers are not used in many applications. The actual exhaust system used can take many forms but it will always be doing one thing above all else; providing a pressure/time history at the exhaust port which will either help or hinder engine performance.

In most industrial applications the exhaust system used is not really a system at all, in that it prohibits the use of any beneficial gas dynamic process due to its inability to provide an adequate length of pipe to obtain correct wave propagation and phasing. Where space is really at a premium, this type of system takes the form of a box with inadequate volume and outlet area, which is bolted directly to the exhaust flange. It is really only an exhaust pulse attenuating device (a muffler) but, if proportioned correctly with regard to itself and the rest of the power unit, will allow the engine to run fairly satisfactorily if the silencing requirements are not too severe. However, if the volume and/or outlet area are too small in relation to the remainder of the power unit, then the pressure in the box during the scavenging period can increase to the point where it will substantially reduce the flow and there will be sufficient charge dilution to cause poor performance and/or thermal problems and even engine failure.

Since the two pistons are identical and in cyclic phase with each other, it appears that this 180° opposed twin should function, gas dynamically, as a single cylinder engine with twice the displacement of one piston. Because of dimensional variations and the effects of rotation of the crankshaft, however, the flow system will not have perfect symmetry. With the common crankcase, dynamic effects in significant lengths of transfer and exhaust ducts could aggravate any influence of asymmetry and unbalance the distribution of the fresh charge transferred to the two cylinders. For a muffler requirement, separate exhaust systems (or a divider) would be utilized if a common chamber tended to compound this problem. A crankcase divider would be considered, if necessary, to completely separate the two flow systems.

#### INSTALLATION CONSTRAINTS

##### Full Expansion Chamber Exhaust System

From a review of not only the torque/speed characteristic required from the engine but also of the space constraints imposed by the vehicle installation, it appears that the use of a full expansion chamber type exhaust system is not practical. Even if the expansion chamber were to be coiled, as opposed to a conventional elongated version, it appears that the required volume would not be readily available within the confines of the vehicle.

##### Extraction System

Even though a full expansion chamber may not be applicable, it is still possible to obtain some benefit from the use of correctly timed pressure waves. An exhaust system design which has been found to be advantageous uses a short length (12-15 inches) of small angle divergent cone (2-3° total angle) attached directly to the exhaust flange of the cylinder. The effect of this cone is to propagate back to the cylinder a small amplitude (0.2-0.3 atmosphere) negative wave during and slightly after the blowdown phase and then act as a diffuser during the scavenge flow period.

During the blowdown phase, no additional flow through the exhaust port will be realized by the negative wave since the pressure ratio across the port will already be above the critical value for choked flow (approximately 1.9:0). After this pressure ratio has decreased below the critical value, the negative wave aids in the removal from the cylinder of burned gas that would otherwise remain there and dilute the new fresh charge supplied through the transfer ports.

##### Exhaust System Volume Required for Exhaust Noise Reduction

Whether the exhaust system comprises lengths of tubing and/

or an exhaust box of some form, it will have a total volume into which the exhaust gases from the cylinder can expand. In order to evolve a satisfactory exhaust system, many variables must be considered in the design. It is possible to draw up a matrix indicating the effect of changing one of these variables on the remaining parameters while still maintaining an acceptable exhaust system. Some of the variables involved in the matrix include cylinder capacity, engine speed, BMEP, exhaust system volume, exhaust system outlet area, sound level, and crankcase compression ratio. With one or more of the variables defined, the remainder can be modified within the space and torque curve constraints to provide a usable exhaust system.

As an example, it would be possible to define all the variables except the crankcase compression ratio, outlet area, and sound level. With a low crankcase compression ratio (1.25-1.35:1), the acceptable outlet area will be relatively large since the pumping pressure generated in the crankcase will be small and therefore not capable of delivering the requisite quantity of air against a high exhaust back pressure. With a high crankcase compression ratio (1.4-1.5:1), the outlet area can be made smaller since the high pumping pressure generated in the crankcase will now be capable of delivering the required amount of air against a high exhaust system pressure. The size of the outlet area for a given exhaust volume more or less directly determines the exhaust noise level due to the degree of attenuation given to the exhaust blowdown pulse before being transmitted into the atmosphere.

#### ANALYSIS OF EXHAUST BOX

The use of several different types of silencer elements are possible but only the exhaust box has been found to be practical within the space/volume constraints imposed by a RPV installation.

The exhaust box volume is dictated by both the space available and the degree of allowable propeller blockage. The outlet area is then calculated from this volume knowing the engine speed, engine capacity and muffler power loss. To achieve the optimum degree of sound reduction multi-chamber mufflers are preferred since this insures more complete expansion of the exhaust pulses.

In order to keep the total engine height to a minimum it was decided to restrict the exhaust box height to two inches and use the available volume under and between the cylinders for the primary muffler volume. A primary muffler volume of 103.5 in<sup>3</sup> was calculated from a preliminary layout. The secondary chamber attaches to the rear plate of the primary muffler and extends under the alternator mounting bracket. For the same muffler width the secondary muffler volume calculated out to be 36.8 in<sup>3</sup>.

The flow outlet areas were calculated as follows:

(1) Primary outlet area

$$\frac{\text{Muffler Volume } 103.5 \text{ in}^3}{\text{Engine Volume } 16.72 \text{ in}^3} = 6.19$$

For a known muffler/engine ratio of 6.0, a volume ratio of 0.16 in<sup>2</sup> of muffler area per in<sup>3</sup> of engine displacement has in past experience been known to give good results for an engine running at 7000 rpm producing 64 psi BMEP.

$$\begin{aligned} \text{Outlet area} &= 0.16 \text{ in}^2/\text{in}^3 \times 16.72 \text{ in}^3 \\ &= 2.675 \text{ in}^2 \end{aligned}$$

For the 2.675 in<sup>2</sup> area the following pipe sizes have been selected:

$$2 \text{ (1 } 5/16 \text{ tubes)} = 2.7 \text{ in}^2$$

(2) Secondary outlet area

$$\begin{aligned} \text{Total muffler volume} &= 103.5 \text{ in}^3 + 36.8 \text{ in}^3 \\ &= 140.3 \text{ in}^3 \end{aligned}$$

$$\frac{\text{Muffler Volume } 140.3 \text{ in}^3}{\text{Engine displacement } 16.72 \text{ in}^3} = 8.39$$

For a known muffler/engine ratio of 8.0, a volume ratio of 0.14 in<sup>2</sup> of muffler per in<sup>3</sup> of engine displacement is chosen, therefore, requiring the following outlet area:

$$\begin{aligned} \text{Outlet Area} &= .14 \text{ in}^2/\text{in}^3 \times 16.72 \text{ in}^3 \\ &= 2.34 \text{ in}^2 \end{aligned}$$

For the above 2.34 in<sup>2</sup> area the following pipe sizes were selected:

$$2 \text{ (1 } 1/4 \text{ tubes)} = 2.454 \text{ in}^2$$

## APPENDIX C

### TCM TEST FACILITY

TCM's facility used during this program is located in Building 26, which is a part of the overall engineering development complex. The area involved encompasses some 2,000 ft<sup>2</sup> of space and includes: three (3) test cells (1 dynamometer and 2 propeller type), operator control rooms, and an adjoining assembly area of 600 ft<sup>2</sup> equipped for complete assembly of RPV engines. The test cells are fully equipped and instrumented for development type engine testing functions. A floor plan of this area is shown in Figure C-1.

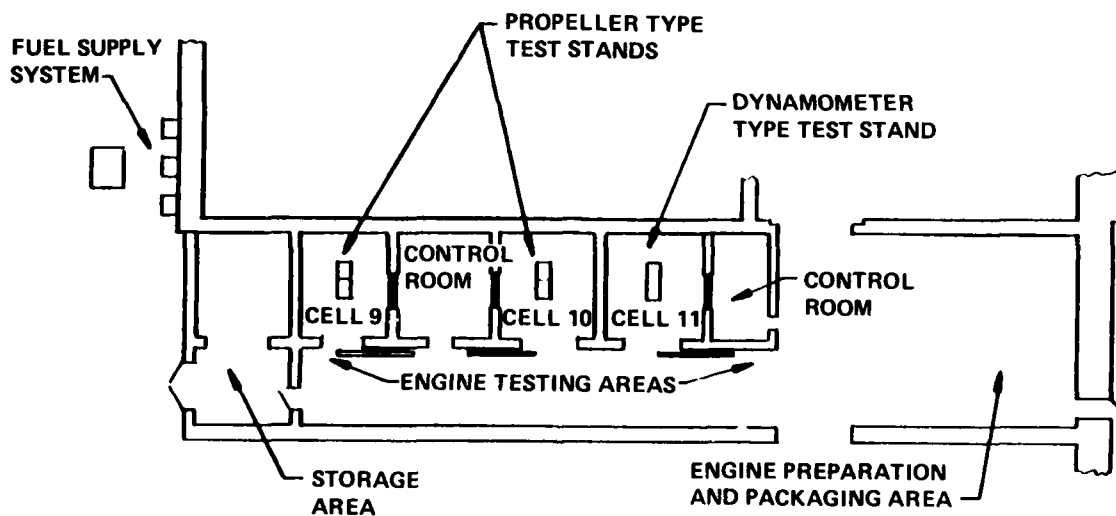


FIGURE C-1. FLOOR PLAN OF THE MINI-RPV AREA LOCATED IN BUILDING NO. 26.

#### DYNAMOMETER STAND

Engine power development was performed in the dynamometer test cell shown in Figure C-2.

The dynamometer test cell (Cell 11) is equipped with instrumentation for the following measurements:

(1) Measurement - Cooling Air

Inclined Manometer  
Model No. 442BA35WM  
Serial No. L22984  
Range: 8 to 48"  
Reads out directly in P.P.H. and C.F.M.  
Adjustable for barometer and temperature

Meriam Instrument Co.

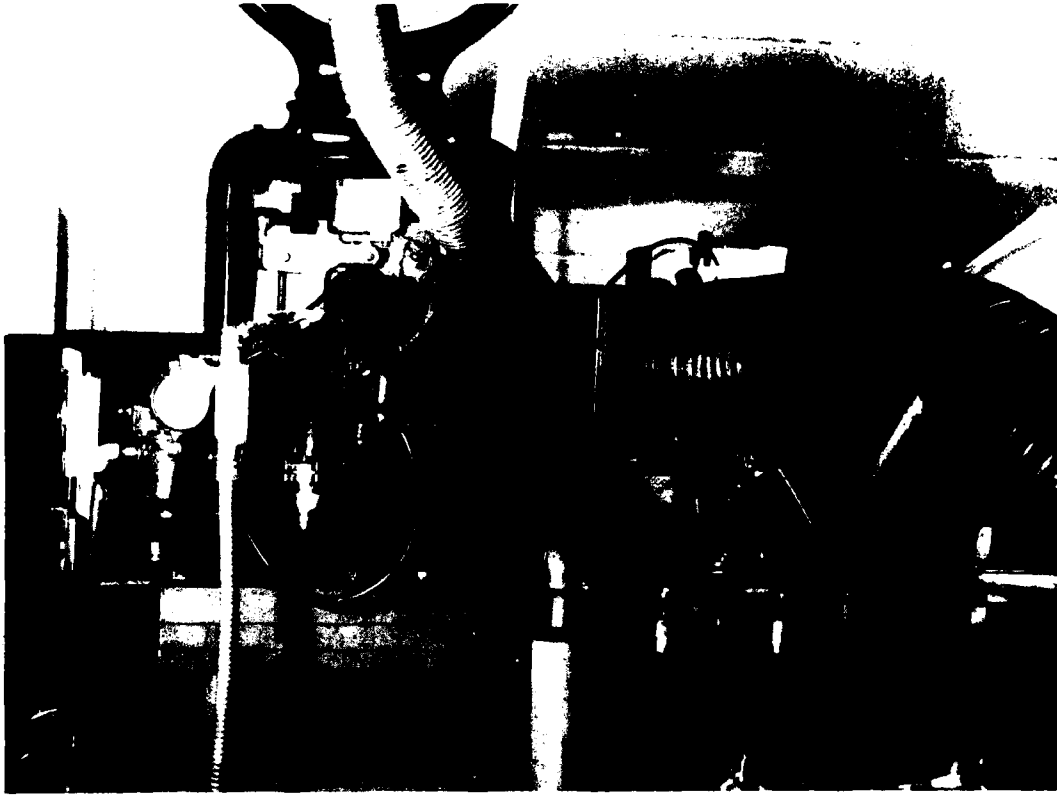


FIGURE C-2. TCM MINI-RPV DYNAMOMETER TEST CELL.

Laminar Flow Meter  
Model No. 50MC2-8                      Meriam Instrument Co.  
Serial No. L22981  
Range: 2000 CFM @ 8" H<sub>2</sub>O, 70° F and 29.92" Hg. Abs.

8" diameter rigid pipe into unit, 8" flexible  
tube to separator, 2-4" flex tube into engine.

(2) Measurement - Air Consumption

Inclined Manometer  
Model No. 442BA35WM                      Meriam Instrument Co.  
Serial No. L22985  
Range: 8 to 48"  
Reads out directly in P.P.H. and C.F.M.  
Adjustable for barometer and temperature

Laminar Flow Meter  
Model No. 50MC2-2                      Meriam Instrument Co.  
Serial No. L22982  
Range: 100 CFM @ 8" H<sub>2</sub>O, 70° F and 29.92" Hg. Abs.

55 gallon drum - 8" flex tube to engine.

(3) Measurement - Fuel Flow

Model No. 10E  
Part No. 10E66  
Serial No. 59-30  
Range: 5 to 25 P.P.H.  
115V 60HZ

Flo-Tron, Inc.

Regulator - Pressure  
Part No. 41-02  
Serial No. 62-02  
Range: 0 to 10 PSI

Flo-Tron, Inc.

(4) Measurement - Temperature

Switching Unit - 30 Position  
Model No. 3343006  
Serial No. 67095A-2

Thermo Elect. Co.

Digital Readout  
Model No. 3162000 001  
Serial No. A 40261-67095  
Range: -328 to 1712<sup>0</sup>F (J)

Thermo Elect. Co.

Thermocouples  
J Range: -328 to 1712<sup>0</sup>F

Thermo Elect. Co.

(5) Measurement - R.P.M.

Digital Readout  
Model No. CPM 700  
Serial No. 62270-A 115 B  
Range: 0 to 20000,  $\pm 1$  RPM

Anadex Instrument Co.

Alternate R.P.M. Capability  
STROBOTAC  
Type 1538-A  
Range: 110 to 150,000 RPM

General Radio Co.

(6) Measurement - Alternator Loading

Model SLB (3863)  
15 Volts - 100 Amp Single-  
phase AC DC  
Serial No. 27A762 & 27A792  
Wired in series

Sun Elect. Co.

D.C. Voltage  
Model No. 420-G  
Range: 0 to 50  
4" Square Face

Triplett Elect. Inst. Co.



D.C. Ampere  
Range: 0 to 100  
4" Square Face

Simpson Elect. Co.

(7) Measurement - Manifold Pressure

Aircraft Type  
Range: 1.0 to 200 in.Hg.  
3" Round Face

Kollsman Inst. Co.

(8) Measurement - Dyno Control

Load/Speed Controller for  
Water Cooled Eddy Current  
Absorption Dynamometer  
Serial No. 17306  
0-260 Volts 2 Amps D.C.  
Input 230/460 VAC-10

Pohl Assoc. Inc.

Amp Meter  $\pm$  10 D.C.  
Volt Meter  $\pm$  250 D.C.

Midwest Dyna Engr.  
Midwest Dyna Engr.

(9) Measurement - Dyanmometer

Model No. 4-HS-6  
Serial No. 3898  
Rating 50 hp @ 10,000 -  
25,000 R.P.M.  
DC Volts 220, 1.8 Amps

Dynamic Division -  
Eaton

Water Temperature Meter  
Range: 80 to 300<sup>o</sup>F  
No identification

Water Pressure Meter  
Range: 0 to 60 P.S.I.  
No identification

(10) Measurement - Dyna Readout

Scale  
Model No. 9600M  
Serial No. 770949  
Capacity: 70 lbs.

Toledo Scale Co.

PROPELLER STAND

The propeller test stand was arranged as illustrated in Figure C-3 Longitudinal freedom of the engine assembly, restrained by a force transducer, permitted determination of static thrust. The propeller test stand is located in Cell 10 and is

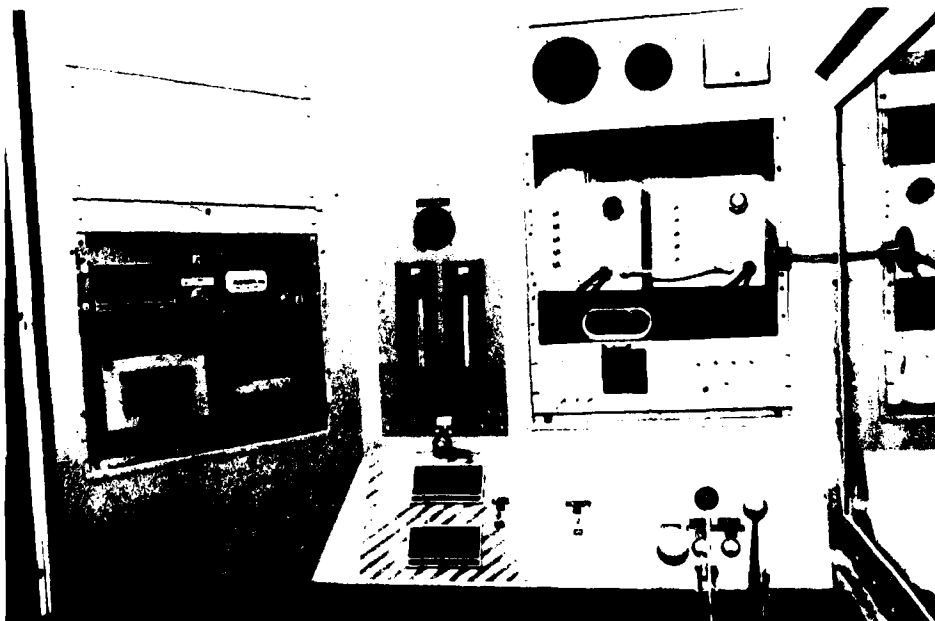
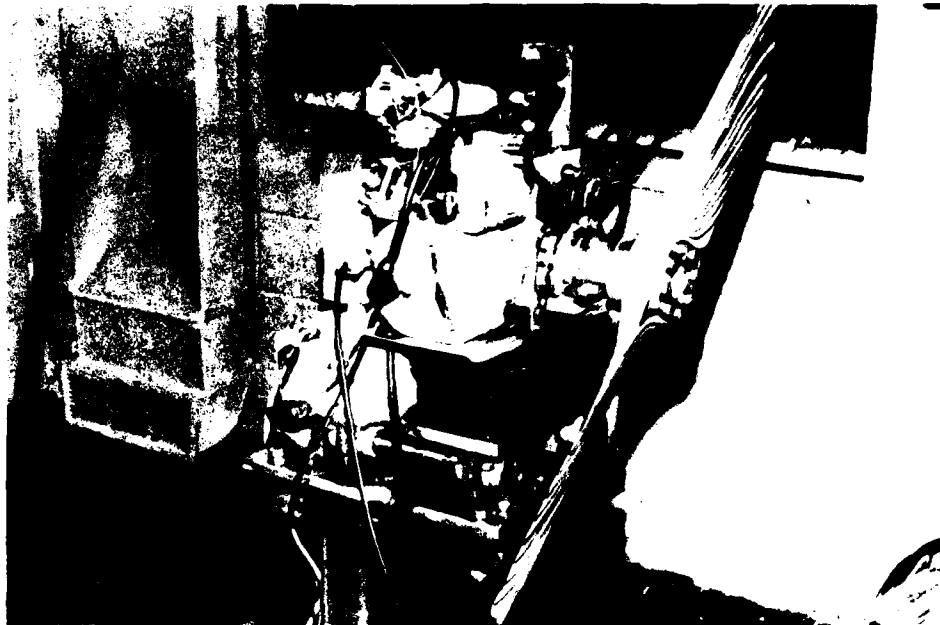


FIGURE C-3. TCM MINI-RPV PROPELLER TEST CELL AND CONTROL ROOM.

equipped with instrumentation for the following measurements:

(1) Measurement - Torque

Strain Gage Digital  
Indicator  
Model No. 700-1                      Daytronic  
Serial No. AJ8E97

(2) Measurement - Load Cell (Thrust)

Model No. 3112-500                      Lebow Assoc.  
Serial No. 279  
Capacity: 500 lbs.

(3) Measurement - Fuel Flow

Model No. 10E                              Flo-Tron, Inc.  
Serial No. 59-31  
Capacity: 5 to 25 P.P.H.

(4) Measurement - Alternator Loading

Model No. SLB                              Sun Elect. Co.  
Serial No. 16A 111 and  
                  29Δ 116  
15 Volt - 100 Amp, Single  
Phase A.C.-D.C.

D.C. Volt Meter                              Simpson Elect. Co.  
0 - 50 Volt Capability

D.C. Amp Meter                              Simpson Elect. Co.  
0 - 100 Amp Capability

(5) Measurement - Temperature

Switching Unit  
30 Position  
Model No. 3343006                      Thermo Elect. Co.  
Serial No. 64522013

Readout Unit  
Model No. 3162000 001                      Thermo Elect. Co.  
Range: -328 to +1712<sup>0</sup>F (J)

Thermocouples                              Thermo Elect. Co.  
Range - J

(6) Measurement - R.P.M.

Readout Type  
Model C.P.M. - 700                      Anadex Inst. Co.  
Serial No. 62271 (A-1150B)

(7) Measurement - Manifold Pressure

Range: 0 to 55" Hg.                      Meriam Instrument Co.

(8) Measurement - Cooling Air Pressure

U-Tube                                      Meriam Instrument Co.  
Range: 50" Water  
Blower  
Model No. 4C108                          Dayton Elect. Co.  
10-5/8" dia. Wheel

Blower Motor  
Capacitor Start, A.C.  
Model No. 6K232B 1 HP                  Dayton Elect. Co.  
115V 60 HZ

6" dia. Inlet - 5-1/2" dia.  
Outlet  
"Y" Split to double 5-1/2"  
dia. to 4" dia. at Engine.

ENDURANCE STAND

With respect to engine mounting, cooling air, engine controls, etc., the endurance test stand is similar to the propeller test stand. The endurance test stand is located in Cell 9 and is equipped with instrumentation for the following measurements:

(1) Measurement - Alternator Loading

Model No. SLB                              Sun Elect. Co.  
Serial Nos. 161 & 29A 102  
Capability 15 Volt 100 Amp  
Single phase AC-DC  
Two units in series

D.C. Volt Meter                          Simpson Elect. Co.  
0 to 50 Capability

D.C. Amp Meter                              Simpson Elect. Co.  
0 to 100 Capability

(2) Measurement - Temperature

Switching Unit - 30 Position

Model No. 3343053  
Serial No. 64522-6

Thermo Elect. Co.

Readout Unit  
Model No. 3162000 001  
Serial No. A-46496-81848  
Range: -328 to +1712<sup>0</sup>F (J)

(3) Measurement - R.P.M.

Readout Type  
Model No. C.P.M. 700  
Serial No. 62273 (A-115-B)

Anadex Inst. Co.

(4) Measurement - Cooling Air Supply

Blower  
Model No. 2C739  
12-1/2" dia. Wheel

Dayton Elect. Co.

Motor  
Model No. 3N084 2 HP  
3450 RPM  
230 Volts 5.6 Amps

Dayton Elect. Co.

6" dia. Inlet - 5-1/2" dia.  
Outlet  
"Y" Split to double 5-1/2"  
dia. to 4" dia. at Engine.

APPENDIX D

ENGINE WEIGHT BREAKDOWN

<u>PART NAME</u>	<u>QTY.</u>	<u>WEIGHT IN GRAMS</u>		<u>REMARKS</u>
		<u>Second Generation Engine</u>	<u>Third Generation Engine</u>	
Crankcase	2 Halves	(1602.0)	(1496.85)	Includes Fasteners
Seal	2	3.5(7)	3.5(7)	
Bearing J-128	2	3.8(27.6)	3.8(27.6)	
J-1212	2	20.8(41.6)	20.8(41.6)	
Gasket	1	15.0	15.0	
Crankshaft	1	(1133.98)	(1496.86)	
Thrust Bearing	2	4.6(9.2)	4.6(9.2)	
Thrust Washer	2	6.2(12.4)	6.2(12.4)	
Connecting Rod	2	119.5(239.0)	119.5(239.0)	With oil hole
Con-Rod-Bearing	2	12.5(25.0)	17(34.0)	
Piston	2	183.4(366.8)	183.4(366.8)	
Piston Pin	2	41.5(83.0)	41.5(83.0)	
Wrist Pin Bearing	2	12.8(25.6)	12.8(25.6)	
Clip Ring	4	.8(3.2)	.8(3.2)	
Piston Rings	4	5.7(22.8)	5.7(22.8)	
Int. Port Covers	2	24(48.0)	--	
Cylinder	2	997.9(1995.81)	997.9(1995.81)	With Com- pression release
Bolts & Washers	8	18.7(149.6)	18.7(149.6)	
Gasket	2	2.15(4.3)	2.15(4.3)	
Intake Manifold	1	(213.0)	(287.0)	
Carburetor	1	(466.0)	(466.0)	With gasket
Reed Block Assy	1	(127.0)	--	
Alternator	1	(3538.02)	(3492.66)	Without con- nectors, with leads
Rotor	1	(1224.7)	(1224.7)	
C-C Nut & Washer	1	(42.9)	(42.9)	
Bolt	4	(112.0)	(112.0)	
Adapter	1	(253.8)	(253.8)	
Total Engine Wt		<u>26 LBS</u>	<u>26.2 LBS</u>	

Weights in brackers ( ) indicate total weight per engine quantity.

## APPENDIX E

### SECOND-GENERATION ENGINE BUILDUP PROCEDURE AND STOCKLIST

#### ENGINE BUILDUP PROCEDURE

(1) Press in the J1212 bearing Part No. ME 10008 into the outboard end of crankcase half ME 10006. This bearing should be pressed just below the seat for the outboard seal on each end of the crankcase of .010 inch.

(2) Press in the J128 bearing into the inboard side of the crankcase. This bearing should be just below the end of the thrust washer seating surface of the cone; however, be careful not to seal off the fuel mixture lubricating hole located between the two bearings when they are installed into the crankcase.

(3) Install oil seal ME 10009 into the outboard seal area of the crankcase half ME 10006. Press this seal down into its bore location until it is flush with the crankcase end face.

(4) Install the 1/4 pipe and 1/4 straight thread tubing fitting into the bottom of crankcase half that will be the front half of the engine. Tap other hole for 10-32 X 5/16 pan head screw, install with Loctite.

(5) Install connecting rod onto crankshaft using ME 10003 rods and ME 10004 split cage bearings. Be careful to align rod cap onto rod with rod cap matching surface fitting precisely as it came apart before tightening the rod cap screws to 86 in-lbs.

(6) Put the crankshaft and rod assembly into one crankcase half at a time. This should be done by installing a thrust bearing ME 10014 onto the crankshaft followed by a .060 thick ME 10013 thrust washer and then sliding that end of the crankshaft into the main bearings of one of the crankcase halves. Turn this crankcase half with the free end of the crankshaft standing upward out of the case and install the crankcase gasket ME 10007.

(7) Install the thrust bearing ME 10014 and thrust washer ME 10013 onto the top end of the crankshaft and install the other half of the crankcase.

(8) Install the four crankcase bolts #24252 with a washer #20522 on each side of all four bolts; then place four lock washers MS 35388-44 and four nuts #2437 onto the bolts and torque them to 90-110 in-lbs.

(9) Check crankshaft end-play with dial indicator; limits are .010-.033 inch.

(10) First measure diameter of cylinder bore just above the exhaust port; from this measurement check the running clearance of the piston by measuring the piston at the places as indicated on the piston print and subtract the piston diameters from the cylinder bore diameter. Check the measured clearances against the clearances as specified by the Stihl drawing.

(11) Install piston pin bearing ME 10019 into rod, then install the piston ME 10017 onto the rod with piston pin ME 10018, secure piston pin using two piston pin retaining clips #DIN 73123. Fit two piston rings #DIN 24919 onto piston.

Make sure arrow on piston points away from reed block area of crankcase.

(12) Bend compression release clips on top of cylinder head so that end of spring touches cylinder fin. Be sure C.R. pin is seated. Install cylinder gasket ME 10010 onto cylinder ME 10022; compress piston rings with piston ring compressor and slip the cylinder over the piston assembly with the exhaust part away from reed block hole.

(13) Secure cylinder to crankcase with four MS 16995-51 screws and four MS 15795-809 flat washers against cylinder flanges, using four MS 35338-44 lock washers between screw head and flat washers. Torque screws to 86 in-lbs.

(14) Install four ME 10072 reed valves .008 thick steel with two reed supports ME 10073 and 8 reed support screws ME 10108 onto reed block ME 10071. Be careful to align reed valve parallel to reed support before tightening the support screws.

(15) Install reed block assembly (ME 10070) into crankcase with reed block gasket ME 10074 sandwiched between reed block and top of crankcase.

(16) Install manifold gasket ME 10075 and intake manifold ME 10076 on top of reed block assembly ME 10070.

Secure in place with four screws MS 16995-53 using four flat washers MS 15795-809 and four lock washers MS 35338-44. Torque manifold screws to 86 in-lbs.

(17) Install two carburetor studs #21167 into manifold ME 10076.

(18) Install carburetor gasket ME 10081 onto intake manifold studs.

Position the Tillotson carburetor ME 10082 in the exact center of the manifold ME 10076 and secure in place with two nuts MS 51968-2 using two flat washers MS 15795-809.



(19) Install 1/8 X 5/8 Woodruff key into crankshaft key slot on front of engine.

(20) Install alternator adaptor ME 10066 with MS 16995-51 screws and ME 15795-809 flat washers. Install Phelon alternator ignition rotor onto crankshaft ME 10060. Secure rotor in place by sticking together a flat washer ME 10028 with a .030 washer spacer ME 10013 and installing onto crankshaft with crankshaft nut ME 10113. Torque to 420 in-lbs.

(21) Install cooling air boxes (shroud) with four M6 X 1.0 screws.

(22) Install intake port cover ME 10080 between cooling shroud and intake port of cylinder with gasket ME 10052.

Number one cylinder intake port cover number 10080 should have fitting ME 10110 installed for connection of carburetor crankcase pulse line. When this cover is installed, punch hole in gasket ME 10052 with hole punch to .094 diameter and when installing cover use a #41 drill .094 to align gasket ME 10052 with cover plate ME 10080 and cylinder puffer post at intake location on cylinder assembly.

Oil port cover gasket before assembly.

(23) Install Tygon tube between puffer post of intake port cover on #2 cylinder and the puffer post location of the Tillotson carburetor. Secure in place with small clamp or safety wire.

STOCKLIST FOR REED CAGE MK II SECOND-GENERATION ENGINE

<u>Drawing No.</u>	<u>Part Name</u>	<u>Qty. Per Engine</u>
ME 10061	<u>Crankshaft &amp; Con-Rod Assy</u>	1
ME 10060	Crankshaft	1
ME 10003	Connecting Rod	2
ME 10004	Bearing - Split Cage	2
ME 10005	<u>Crankcase Assembly</u>	
ME 10006	Crankcase	2
ME 10008-2	Bearing-Cshaft-Outboard J-1212X3/4	2
ME 10008-3	Bearing-Cshaft-Inboard J-128X1/2	2
ME 10009	Oil Seal	
ME 10007	Gasket Crankcase	
ME 10014	Thrust Bearing	2
ME 10013	Thrust Washer TRB-122D	2
ME 10021	Fitting-Anti-Puddling 4/16-32X1/16 Pipe	1
ME 10108	Screw Plug	
ME 10020	Line Assy-Anti-Puddling	
24252	Bolt Crankcase	4
MS 21206-4	Washer - Flat 1/4	4
MS 35340-44	Washer - Lock	
AN 315-4R	Nut 1/4-28	4
ME 10200	Crankcase Mod	1
ME 10201	Adapter "Steel Hub"	2
ME 10203	Crankcase Assy Machine "Drawing"	1
	<u>Piston Assembly</u>	
ME 10017	Piston	2
ME 10018	Pin - Piston	2
ME 10012	Ring-Piston Pin Retaining DIN 73123	4
ME 10011	Ring-Piston - DIN 24919	4
ME 10019	Bearing - Piston Pin	2
	<u>Cylinder Assembly</u>	
ME 10022	Cylinder	2
ME 10010	Gasket - Cylinder	2
MS 16995-51	Screw-Cyl Mtg 1/4-20-7/8 Sock Hd	8
MS 15795-809	Washer - Flat 1/4	8
	<u>Induction System</u>	
ME 10082	Carburetor-HR-43A-Tillotson	1
ME 10081	Gasket - Carburetor	1
ME 10076	Manifold - Cylinder Intake	1
ME 10075	Gasket - Manifold	2
MS 15986-F	Stud-Manifold 1/4-20X1/4-28X1	2
	Pulse Line-Carburetor 5/16 Tygon Tubing	1
6208 Ideal	Clamp - Pulse Line	
MS 51968-2	Nut - Carburetor 1/4-28	2

AD-A083 282    TELEDYNE CONTINENTAL MOTORS    MOBILE AL AIRCRAFT PRODU--ETC    F/G 21/7  
MINI-RPV ENGINE DEMONSTRATOR PROGRAM.(U)  
MAR 80    B J REZY

DAAJ02-77-C-0015

ML

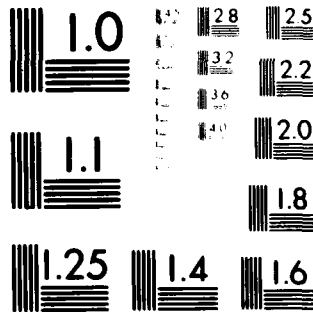
UNCLASSIFIED

USARTL-TR-79-23

2 of 2  
AD-A083 282



END DATE FILMED 5-80 DTIC
---------------------------------------



MICROCOPY RESOLUTION TEST CHART  
 NATIONAL BUREAU OF STANDARDS-1963-A

<u>Drawing No.</u>	<u>Part Name</u>	<u>Qty. Per Engine</u>
MS 16995-53	Screw-Manifold 1/4-20X1-1/4	4
MS 15795-809	Washer-Manifold-Flat 1/4	4
MS 35338-44	Washer - Lock 1/4	4
ME 10070	Reed Block Assembly	1
ME 10071	Reed Block	1
ME 10072-1	Reed - Steel .008 Thick	4
ME 10073	Support - Reed	2
ME 10074	Gasket - Reed Block	1
ME 10108	Screw - Reed 10-32X1/4 Pan Hd	4
ME 10080	Cover - Intake Port	2
ME 10052	Gasket - Intake Port	2
ME 10107-1	Bolt - Intake Port	4
MS 15795-808	Washer - Flat	4
MS 35338-44	Washer - Lock	4
<u>Alternator/Ignition System</u>		
ME 10213	Alternator - Ignition Assy.	1
ME 10211	Rotor	1
ME 10066	Adapter	1
ME 10023	Spark Plug RMJ-3	2
MS 35307-320	Bolt - Top - Alt Stator	2
MS 35307-316	Bolt - Bottom - Alt Stator	2
MS 15795-809	Washer - Flat	4
MS 35349-44	Washer O Lock	4
ME 10028-1	Washer - Rotor - Cshaft	1
	Woodruff Key - Rotor - Cshaft 1/8X5/8	1
MS 16995-51	Screw Adapter - 1/4-20-7/8 Sock Hd	4
MS 15795-809	Washer - Flat	4
MS 35349-44	Washer - Lock	4
<u>Propeller Assembly</u>		
ME 10206	Propeller	1
ME 10205	Hub - Rear Plate	1
ME 10208	Cover - Front Plate	1
ME 10207	Pin - Propeller	6
MS 35307-317	Bolt - 1/4-20-2 3/4	6
MS 15795-809	Washer - Flat	6
MS 35340-44	Washer - Lock	6
<u>Exhaust System</u>		
ME 10100	Exhaust Pipe	1
ME 10135	Gasket - Cylinder Port	2
ME 10107-1	Bolt - M6X1.00	4
MS 35338-44	Washer - Flat	4
MS 35340-44	Washer - Lock	4

## APPENDIX F

### THIRD-GENERATION ENGINE BUILDUP PROCEDURE AND STOCKLIST

#### ENGINE BUILDUP PROCEDURE

##### CRANKCASE ASSEMBLY

(1) With the assistance of an arbor press, press a Torrington bearing No. J-1212 X 3/4" (ME 10008-3) into outboard bore of crankcase half (ME 10084). Bearing must be flush to .010" below seal seat. Care must be taken that the bearing is started straight in the bearing bore.

(2) Repeat Step 1 on opposite crankcase casting.

(3) Press Torrington bearing No. J-128 X 1/2" (ME 10008-2) into inboard end of crankcase bore until flush or .010" below thrust face. Care must be taken that the bearing doesn't cover the lubrication hole in the bearing bore.

(4) Repeat Step 3 on opposite crankcase casting.

(5) Press oil seal (ME 10009) into oil seal bore at outboard end of crankcase. Seal is to press flush to the end of the case.

(6) Repeat Step 5 on opposite crankcase casting.

(7) Remove connecting rod cap from connecting rod (ME 10221). Using white grease or machining wax, cover both sections of the bore. Locate 21-Torrington JH-1312-12 bearing rollers in the greased sections. Take great care that no rollers fall out.

(8) Repeat Step 7 with second rod. WARNING: Do not mix rod caps and rods, as the rod assemblies are created by fracturing the cap section from the main section and there is only one mating section that will match. Also, note that there is only one way that the cap will match to the rod and the assembly must be assembled only in this manner. Mismatching will cause total destruction of the engine.

(9) Install rod assembly on crankshaft. Keep in mind warnings in Step 8 and make sure no rollers drop during assembly. Rod bolt torque value is 86 inch-pounds.

(10) Repeat Step 9 on opposite rod.

(11) Lubricate both oil seals with light oil. Inspect oil seals for installation damage.

(12) Slide thrust bearing (ME 10014) over end of crankshaft until it sets against crankshaft thrust face. Slide thrust washer (ME 10013) over end of crankshaft until it sets against the thrust bearing.

(13) Slide crankshaft assembly into crankcase half until thrust assembly sets against the crankcase thrust face. Take care that the loose bearings and washers do not fall off the crankshaft during this operation. Be sure that the connecting rods protrude out the proper cylinder holes in the crankcase.

(14) Run a bead of Loctite Gasket Eliminator 515 on one crankcase mating face.

(15) Slide second crankcase half over the assembly; align bolt holes.

(16) Install crankcase clamping bolts (AN 174-24) with flat washer (MS 21206-4) under the head. Place flat washer (MS 21206-4) under nut (MS 21043-4) and torque to 90-110 inch-pounds. Clean off any gasket sealer that squeezes out onto the cylinder mounting flange.

(17) Check crankshaft end-play with dial indicator mounted to the engine assembly. Push and pull crankshaft so indicator unit setting on shaft assembly measures total travel. Allowable limits are .010-.033". This can be corrected by changing thrust washers with washers of appropriate thickness. Be sure to divide change between both washers so that the crankshaft remains centered in crankcase.

(18) Check crankshaft side-play with dial indicator at small end of crankshaft taper. Extreme movement should be less than .001 inch. If excessive side-play is apparent, the assembly must be disassembled and main bearings and crankshaft inspected for run-out.

(19) Install one piston pin retaining ring (ME 10012) into piston (ME 10017) pin bore groove. Use long nose pliers to install. Inspect bore to be sure that the ring is completely in groove.

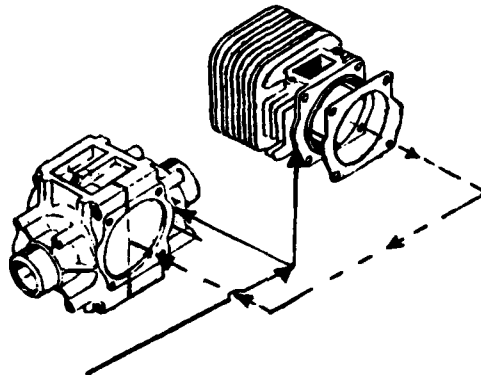
(20) Repeat Step 19 on second piston.

(21) Install piston rings (ME 10011) onto pistons. Spread rings with fingers to prevent damage of piston during installation. Make sure that the rings are orientated such that the ring ends fit around the ring locating pins in the piston grooves.

(22) Install piston-pin bearing (ME 10019) into small end of connecting rod. Be careful this bearing doesn't fall out during assembly.

(23) Slide piston-pin (ME 10018) into one piston boss; do not let it protrude into space between bosses. Slide piston over small end of connecting rod, align bores and push piston pin thru until it mates up with the piston-pin retaining ring. Install second piston-pin retaining ring into exposed groove of piston boss.

(23A) Note sketch below before installing piston on connecting rod in Step 23. Piston to connecting rod orientation must be correct to prevent the piston from being installed upside down which would allow the piston ring ends to clip into the cylinder port openings and damage the engine. At this point of assembly the only point of orientation is the cylinder deck outside configuration and the arrow on the top of the piston or the location of the ring location pins.



Deck Radius Must Match When Assembled.

(24) Repeat Steps 21-23, noting Step 23A on opposite assembly.

(25) Locate cylinder gasket (ME 10010) on either crankcase cylinder mounting pad or cylinder flange. Be sure outside configurations match each other. Locate ring ends on each side of ring locating pins in piston ring grooves and compress rings using a ring compressor or simple soft metal strap held together with the fingers. Slide oiled cylinder over piston with cylinder in proper orientation (note Step 23A) and push ring compressor out of the way. Align holes and fasten with 4 MS 16995-51, 1/4-20 X 7/8 socket head screws with MS 15795-809 flat washers under the head. Torque to 86 inch-pounds. Torquing operation requires a 3/16 X 4" straight Allen socket. Repeat torquing procedure at least twice. NOTE: Should the cylinder be slid over the piston in an improper orientation, do not attempt to rotate the cylinder around the piston. This will result in broken rings. The cylinder must be removed and replaced in a proper orientation.

(26) Repeat Step 25 on opposite cylinder.



(27) Lay engine down so that the manifold gaskets (ME 10052) can be placed on each intake port flange. Make sure that the gasket covers the pulse hole area which is not used in this engine.

(28) Install the cylinder intake manifold (ME 10088) on the above gaskets and bolt to the cylinder using M6 x 1.00 hex head bolts. Torque to 86 inch-pounds. The orientation of the manifold now determines the front and back of the engine, the manifold outlet facing away from the propeller end.

(29) Install carburetor gasket (ME 10081) over the carburetor mounting studs. Install carburetor (ME 10082) in the inverted position, with the fuel inlet on top. Bolt in position with 1/4 x 28 lock nuts.

(30) Install 5/16 Tygon tubing from fitting on top of crankcase to large metal fitting on carburetor. Use hose clamps or safety-wire to prevent any air leaks. Make sure the line does not have any kinks to block clear passage.

(31) Install anti-puddling fitting (ME 10021) into hole in bottom of the crankcase.

(32) Install anti-puddling line (ME 10020) onto fitting, locating bent line so that it fits close to the cylinder base and it ends up close to the pulse line fitting in the base of the carburetor. Tighten line fitting. Connect opening of line to carburetor fitting with small diameter plastic hose.

(33) Install alternator adapter (ME 10066) onto end of crankcase away from the carburetor. Align holes and bolt down with 1/4-20x1"L hex head machine screws torqued to 86 inch-pounds. Do not install lock washers under screw heads because of low clearance between the stator windings and the bolt heads.

(34) Install 3/16 x 3/4 Woodruff key into keyway in alternator end of crankshaft.

(35) Install alternator rotor onto keyed end of crankshaft. Install special washer (ME 10028) over rotor. Torque down 1/2-20 UNF-3 selflocking nut to 300 inch-pounds.

(36) Install alternator stator over rotor, make sure it seats well on adapter seat.

(37) Bolt stator to adapter using 1/4-20 x 3-1/2"L hex head machine screws with lock and flat washers in the upper holes and 1/4-20 x 2-1/2"L socket head machine screws with lock and flat washers in the lower holes. Torque to 86 inch-pounds. Pull down carefully to prevent improper seating of the stator. This can cause rotor-stator contact.

(38) Install spark plug leads (ME 10040) into proper plugs in end of stator.

(39) Install male cannon plugs into female receptacles on stator.

MS 3106A12-5P (Large) = Current output  
MS 3106A85-1P (Small) = Ignition kill

(40) Slip cylinder shrouds over cylinders so that the exhaust port hole matches the exhaust opening in the cylinder. Leave loose until the muffler is installed.

(41) Repeat opposite shroud.

(42) Turn engine over and locate muffler gaskets on flanges (ME 10135). Place muffler on engine with exhaust openings toward the alternator. Install M6 x 1.0 muffler bolts and torque to 86 inch-pounds. Safety wire screws to prevent loosening.

(43) Press propeller pins (ME 10207) into holes provided in propeller hub.

(44) Press front cover plate (ME 10208) and rear hub plate (ME 10205) into propeller hub making sure that they align with the pins protruding out of the hub. Note that the engine rotates in a counterclockwise direction as viewed from the propeller end and it is possible to install the propeller backwards.

(45) Line up six-bolt pattern and press propeller assembly on to alternator rotor. Install 6 - 1/4-20 x 2-3/4"L hex head machine screws with lock washers and torque to 70 inch-pounds.

(46) Safety wire bolts in patterns of three.

(47) Install Champion RMJ-3 spark plugs (ME 10023) into the spark plug holes. Torque to 50-60 inch-pounds; attach leads.

Engine is now ready for the test stand or vehicle.

STOCKLIST FOR PISTON PORTED MK II THIRD-GENERATION ENGINE

<u>Drawing No.</u>	<u>Part Name</u>	<u>Qty. Per Engine</u>
	<u>Engine Assembly</u>	
ME 10220	Assembly Drawing MK II Engine	Ref.
ME 10216	Engine Outline Drawing	Ref.
	<u>Crankshaft &amp; Con-Rod Assy</u>	
ME 10058	Crankshaft	1
ME 10221	Connecting Rod Assembly	2
ME 10218	Con-Rod Bearing-21 Torrington JH-1312-R	42
	<u>Crankcase Assembly</u>	
ME 10084	Crankcase	2
ME 10008-2	Bearing-Cshaft-Outboard J-128X1/2	2
ME 10008-3	Bearing-Cshaft-Inboard J-1212X3/4	2
ME 10009	Oil Seal	2
	Gasket Crankcase Loctite #515	
ME 10014	Thrust Bearing	2
ME 10013	Thrust Washer TRB-122D	2
ME 10021	Fitting-Anti-Puddling 5/16-32X1/16 Pipe	1
ME 10020	Line Assy-Anti-Puddling	
AN174-24	Bolt Crankcase	4
MS 21206-4	Washer - Flat 1/4	4
MS 21043-4	Nut 1/4-28	4
	<u>Piston Assembly</u>	
ME 10017	Piston	2
ME 10018	Pin - Piston	2
ME 10012	Ring-Piston Pin Retaining DIN 73123	4
ME 10011	Ring-Piston - DIN 24919	4
ME 10019	Bearing - Piston Pin	2
	<u>Cylinder Assembly</u>	
ME 10022	Cylinder	2
ME 10010	Gasket - Cylinder	2
MS 16995-51	Screw-Cyl Mtg 1/4-20-7/8 Sock Hd	8
MS 15795-809	Washer - Flat 1/4	8
	<u>Induction System</u>	
ME 10082	Carburetor-HR-43A-Tillotson	1
ME 10081	Gasket - Carburetor	1
ME 10088	Manifold - Cylinder Intake	1
ME 10052	Gasket - Manifold	2
MS 15986-F	Stud-Manifold 1/4-20X1/4-28X1	2
	Pulse Line-Carburetor 5/16 Tygon Tubing	1
6208 Ideal	Clamp - Pulse Line	
MS 51968-2	Nut - Carburetor 1/4-28	2
ME 10107-4	Bolt - Manifold M6X1.00	4
MS 15795-808	Washer - Flat	4

<u>Drawing No.</u>	<u>Part Name</u>	<u>Qty. Per Engine</u>
	<u>Alternator/Ignition Assembly</u>	
ME 10214	Alternator-Ignition Assy.	1
ME 10212	Rotor	1
ME 10066	Adapter	1
ME 10040	Leads - Spark Plug	2
MS 3106A12-SP	Lead - Current Output	1
MS 3106A8S-1P	Lead - Ignition-Kill	1
ME 10023	Spark Plug RMJ-3	2
MS 35307-320	Bolt - Top - Alt Stator	2
MS 35307-316	Bolt - Bottom - Alt Stator	2
MS 15795-809	Washer - Flat	4
MS 35349-44	Washer - Lock	4
ME 10028-2	Washer - Rotor - C'shaft	1
MS 35756-12	Key - Rotor - C'shaft	
MS 20503-820	Nut - Crankshaft	1
MS 24677-36	Screw - Socket Hd.	4
	<u>Propeller Assembly</u>	
ME 10206	Propeller	1
ME 10205	Hub-Rear Plate	1
ME 10208	Cover - Front Plate	1
ME 10207	Pins - Propeller	6
MS 35307-317	Bolts 1/4-20-2 3/4	6
MS 15795-809	Washer - Flat	6
MS 35340-44	Washer - Lock	6
	<u>Exhaust System</u>	
ME 10101	Muffler Box	1
ME 10135	Gasket - Cylinder Port	2
ME 10107-3	Bolts M6X1.00	4
MS 15795-808	Washer - Flat	4
MS 35340-44	Washer - Lock	4