

AD-A083 036

MANUFACTURING METHODS & TECHNOLOGY PROJECT EXECUTION
REPORT SECOND HALF CY79(U) ARMY INDUSTRIAL BASE
ENGINEERING ACTIVITY ROCK ISLAND IL H E WEIDNER ET AL.

1/2

UNCLASSIFIED

MAR 80

F/G 13/8

NL

The image shows a microfiche grid with 12 columns and 12 rows of frames. Several frames contain small white marks, likely artifacts or data points. The marks are located in the following frames (row, column): (1, 2), (1, 8), (2, 1), (2, 3), (3, 4), (4, 2), (4, 4), (5, 4), (5, 5), (6, 2), (6, 4), (6, 5), (6, 6), (6, 7), (6, 8), (6, 9), (6, 10), (6, 11), (6, 12), (7, 2), (7, 3), (7, 4), (7, 5), (7, 6), (7, 7), (7, 8), (7, 9), (7, 10), (7, 11), (7, 12), (8, 2), (8, 3), (8, 4), (8, 5), (8, 6), (8, 7), (8, 8), (8, 9), (8, 10), (8, 11), (8, 12), (9, 2), (9, 3), (9, 4), (9, 5), (9, 6), (9, 7), (9, 8), (9, 9), (9, 10), (9, 11), (9, 12), (10, 2), (10, 3), (10, 4), (10, 5), (10, 6), (10, 7), (10, 8), (10, 9), (10, 10), (10, 11), (10, 12), (11, 2), (11, 3), (11, 4), (11, 5), (11, 6), (11, 7), (11, 8), (11, 9), (11, 10), (11, 11), (11, 12), (12, 2), (12, 3), (12, 4), (12, 5), (12, 6), (12, 7), (12, 8), (12, 9), (12, 10), (12, 11), (12, 12).

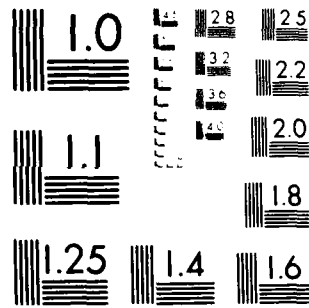

MICROCOPY RESOLUTION TEST CHART
NATIONAL BUREAU OF STANDARDS-1963-A

U.S. ARMY
MATERIEL DEVELOPMENT
AND READINESS COMMAND

12

ADA 083036

~~LEVEL~~

DTIC
DIRECTORATE
C



MANUFACTURING
METHODS &
TECHNOLOGY

**PROJECT EXECUTION
REPORT**

This document has been approved
for public release and sale; its
distribution is unlimited.

SECOND CY 79

UNCLASIFIED COPY

PREPARED BY

MARCH 1980

USA INDUSTRIAL BASE ENGINEERING ACTIVITY

MANUFACTURING TECHNOLOGY DIVISION

ROCK ISLAND, ILLINOIS 61299

80

4 15 022

UNCLASSIFIED

SECURITY CLASSIFICATION OF THIS PAGE (When Data Entered)

REPORT DOCUMENTATION PAGE		READ INSTRUCTIONS BEFORE COMPLETING FORM
1. REPORT NUMBER SECOND CY 79	2. GOVT ACCESSION NO.	3. RECIPIENT'S CATALOG NUMBER
4. TITLE (and Subtitle) MANUFACTURING METHODS & TECHNOLOGY PROJECT EXECUTION REPORT. <i>Second half CY 79.</i>		5. TYPE OF REPORT & PERIOD COVERED Semiannual Report, 1 Jul 79 - 31 Dec 79.
6. AUTHOR(s) Mr. H. E. Weidner Ms. L. S. Hancock		6. PERFORMING ORG. REPORT NUMBER
9. PERFORMING ORGANIZATION NAME AND ADDRESS US Army Industrial Base Engineering Activity ATTN: DRXIB-MT Rock Island, IL 61299		8. CONTRACT OR GRANT NUMBER(s) N/A
11. CONTROLLING OFFICE NAME AND ADDRESS US Army Industrial Base Engineering Activity ATTN: DRXIB-MT Rock Island, IL 61299		10. PROGRAM ELEMENT, PROJECT, TASK AREA & WORK UNIT NUMBERS N/A <i>(12/79)</i>
14. MONITORING AGENCY NAME & ADDRESS (if different from Controlling Office) US Army Materiel Development & Readiness Command ATTN: DRCMT, Office of Manufacturing Technology 5001 Eisenhower Avenue Alexandria, VA 22333		12. REPORT DATE Mar 1980
16. DISTRIBUTION STATEMENT (of this Report) DISTRIBUTION UNLIMITED		13. NUMBER OF PAGES 208
17. DISTRIBUTION STATEMENT (of the abstract entered in Block 20, if different from Report) DISTRIBUTION UNLIMITED		15. SECURITY CLASS. (of this report) UNCLASSIFIED
18. SUPPLEMENTARY NOTES N/A		15a. DECLASSIFICATION/DOWNGRADING SCHEDULE N/A
19. KEY WORDS (Continue on reverse side if necessary and identify by block number) Manufacturing Methods & Technology MMT		
20. ABSTRACT (Continue on reverse side if necessary and identify by block number) This document is a summary compilation of the Manufacturing Methods and Technology Program Project Status Reports (RCS DRCMT-301) submitted to IBEA from DARCOM major subordinate commands and project managers. Each page of the computerized section lists project number, title, status, funding, and projected completion date. Summary pages give information relating to the overall DARCOM program.		

DD FORM 1 JAN 73 1473 EDITION OF 1 NOV 65 IS OBSOLETE

UNCLASSIFIED

SECURITY CLASSIFICATION OF THIS PAGE (When Data Entered)

415713



DEPARTMENT OF THE ARMY
US ARMY INDUSTRIAL BASE ENGINEERING ACTIVITY
ROCK ISLAND, ILLINOIS 61299

DRXIB-MT

13 MAR 1980

SUBJECT: Manufacturing Methods and Technology (MMT) Program Project
Execution Report, Second Half CY79

SEE DISTRIBUTION

1. Reference Logistics, Army Industrial Preparedness Program, dated 10 March 1977, paragraph 3-8e(1) of AR 700-90.
2. The Project Execution Report is a summary compilation of the MMT Program Project Status Reports (RCS DRCMT-301) submitted to IBEA from DARCOM subordinate major commands (SUBMACOM) and project managers. This document is used as a management tool for monitoring the progress of MMT projects. There are separate sections in the report showing projects that are new, active, and completed. Also, included is a section on project slippage.
3. Persons who are interested in the details of an individual project should contact the manufacturing technology representative at the SUBMACOM. A list of those representatives is included in Appendix III to this report. Project officers for this task were Ms. Hancock and Mr. Weidner, AV 793-6521.

James W. Carstens

JAMES W. CARSTENS
Acting Director
Industrial Base Engineering Activity

Accession For	
NTIS GRA&I	<input checked="" type="checkbox"/>
DIC TAB	<input type="checkbox"/>
Unannounced	<input type="checkbox"/>
Justification	
By _____	
Distribution/	
Availability	
Dist	Acquisition special
A	

TABLE OF CONTENTS

	<u>Page</u>
INTRODUCTION	1
DISCUSSION	5
PROJECT SLIPPAGE STUDY	17
PROJECTS ADDED 2nd HALF, CY79	21
PROJECTS COMPLETED 2nd HALF, CY79	51
SUMMARY PROJECT STATUS REPORTS	65
<i>communications are provided</i> Test and Evaluation Command ,	67
Aviation R&D Command ,	75
Armament R&D Command	
Armament Materiel Readiness Commands (Ammunition)	85
Armament R&D Command	
Armament Materiel Readiness Command (Weapons) ,	115
Mobility Equipment R&D Command ,	127
Communications R&D Command ,	131
Electronics R&D Command ,	135
Army Material and Mechanics Research Center - Materiel Development & Readiness Command ,	145
Natick R&D Command ,	161
Missile Command ,	165
Tank-Automotive R&D Command	
Tank-Automotive Materiel Readiness Command ,	179
APPENDICES	187
I - Command Identification	189
II - User's Guide	193
III - Army MMT Program Representatives	197
DISTRIBUTION	203

INTRODUCTION

BACKGROUND

The Army Manufacturing Methods and Technology (MMT) Program was established in 1964 as a part of the Army Production Base Support (PBS) Program. The MMT Program has goals of improving existing manufacturing technology, translating new technology into production line processes, and supporting the modernization and expansion of the military hardware production base. Army Regulation 700-90, C1, paragraph 3-6, describes the objectives of the MMT Program as follows:

To develop, on a timely basis, manufacturing processes, techniques, and equipment for use in production of Army materiel. In achieving this objective, strong consideration will be given to efforts that insure producibility, reduce costs or lead times, relieve critical materiel/materials shortages, enhance safety, provide for abatement of pollutants, improve product quality and reliability, and advance the state-of-the-art in manufacturing methods and equipment.

AUTHORIZATION

This MMT Project Execution Report provides the status summaries of 646 active projects with an authorized cost of \$286,191,900. The report is compiled, edited, and published for HQ, DARCOM by the Manufacturing Technology Division of the Army Industrial Base Engineering Activity (IBEA) according to AR 700-90, C1, paragraph 3-8e(1).

Distribution of this report is extended to Army materiel developers and users and to counterparts in the Navy and the Air Force. Inquiries on the detailed technical aspects of any individual project may be answered by the MMT Program representative of the action command under which the project was completed or is being executed. Inquiries or suggestions may also be directed to the Manufacturing Technology Division of IBEA.

COMPOSITION OF THE REPORT

The report is composed of five major sections:

Discussion. A summary of important information that relates to the overall DARCOM program. This section discusses changes in funding and includes data on expenditures of funds.

Project Slippage Study. A study of the trends in the timeliness of MMT project execution.

Projects Added 2nd Half, CY79. A list divided by organization of all projects funded during the second half of CY79. Included is a narrative of the problem for each project.

Projects Completed 2nd Half, CY79. A list divided by organization of all projects completed during the second half of CY79. Included is a narrative of the final status for each project.

Summary Project Status Report. These reports are divided by organization and include a summary of funding by fiscal year and a narrative status for each project.

MMT PROGRAM

DISCUSSION



PRECEDING PAGE BLANK-NOT FILMED

MANUFACTURING METHODS AND TECHNOLOGY PROGRAM

This discussion will summarize the overall MMT project reporting and funding status for the 2nd half of CY79. The summary includes data from the DARCOM Major Subordinate Commands (MSC) that have active projects and the AMMRC and DARCOM sponsored projects. Cumulative figures are provided relative to the number of projects by fiscal years, and the distribution and expenditures of funds on contract and in-house. Completed projects are not included in this section. They are listed in a separate section on page 51 which gives the final work status for each project that was completed during this reporting period.

A summary of the MMT program (Figure 1) indicates that the number of active projects has increased by 19%. This increase resulted from the addition of 172 FY80 projects and the completion of 71 projects. Numerically, the largest increases were in Ammunition, Weapons, Aviation, and Tank-Automotive. ARRADCOM/ARRCOM (Ammunition) reflects the largest increase in funding level with additional authorized funds of \$14.9 million. This is due to the release of \$30.4 million in FY80 funds and a close-out of \$15.5 million in prior year funds.

A breakout of the active projects by fiscal year is shown in Figure 2. These figures reflect a relatively small change from the previous period. The median fiscal year for the active projects is FY78, which is the same as last report period. Also, the total span of the active MMT program remains at seven years. The one remaining FY73 project has been given a time extension to September 1980. This is to allow for debugging of the equipment.

Figure 3 indicates at what rate the project funds are being expended. The percent of contract funds expended has increased by 4% from the previous period. The percent of in-house expenditures is down because of the additional FY80 funds. The recent release of FY80 funds also contributes to the high percentage of funds remaining in-house. Excluding FY80 funding, approximately 56% of the funds have been contracted to private industry.

PRECEDING PAGE BLANK-NOT FILMED

Accuracy of project information depends on the quality of the project status reports submitted to IBEA from the commands. Efforts were again made this period to improve the quality of individual reports. Any report containing significant errors or inadequate description of accomplishments was sent back to the command for correction.

Accuracy also depends on a complete submission of all the project status reports for each command. In December a call letter was mailed out to each MSC. Inclosed with this letter was a computerized listing of the projects for which a semiannual report was required for this reporting period. There were 64 reports, which seven weeks after the due date, were not submitted. This is similar to the number of delinquent reports during the last report period. This delinquency creates a void in the information presented in the compiled report. Sixty-two of these delinquent reports were from the Aviation Research and Development Command (AVRADCOM). AVRADCOM has been informed of the earlier publication date of this report. In the future, AVRADCOM will be expected to provide a more timely submission of status reports. This will insure a more useful review of the progression of the MMT Program.

PRECEDING PAGE BLANK-NOT FILMED

MMT PROGRAM SUMMARY

Organization	Number of Projects			Funding Status		
	Previous Period	This Period	Percent Change	Previous Period	This Period	Percent Change
TECOM	3	4	+33	2,479,800	3,267,400	+32
AVRADCOM	72	93	+29	21,343,400	25,216,600	+18
ARRADCOM/ARRCOM (Ammo)	201	229	+14	118,162,700	133,051,800	+17
ARRADCOM/ARRCOM (Weapons)	72	96	+33	12,375,300	17,335,600	+40
MERADCOM	20	21	+ 5	5,184,000	6,353,000	+23
CORADCOM	10	10	0	5,052,100	4,443,600	-12
ERADCOM	45	48	+ 7	24,535,500	28,148,100	+15
AMMRC/DARCOM	16	13	-19	24,236,000	20,671,900	-15
NARADCOM	4	5	+25	853,100	1,506,600	+77
MICOM	62	74	+19	24,560,000	28,979,300	+18
TARADCOM/TARCOM	38	53	+39	12,231,000	17,218,000	+41
TOTAL	543	646	+19	251,012,900	286,191,900	+14

Figure 1

PRECEDING PAGE BLANK-NOT FILMED

ACTIVE PROJECTS BY FISCAL YEAR

Organization	73	74	75	76	77	77	78	79	80	TOTAL
TECOM						1	1	1	1	4
AVRADCOM		1	7	6		10	19	27	23	93
ARRADCOM/ARRCOM (Ammo)		4	6	17	4	29	52	62	55	229
ARRADCOM/ARRCOM (Weapons)	1		2	1		18	21	23	30	96
MERADCOM						1	5	9	6	21
CORADCOM				3		1	2	2	2	10
ERADCOM				7		14	6	10	11	48
AMMRC/DARCOM				1	1	2	3	3	3	13
NARADCOM				2		1		2		5
MICOM				1		6	23	23	21	74
TARADCOM/TARCOM				2	1	3	9	19	19	53
TOTAL	1	5	15	40	6	86	141	181	171	646

Figure 2

PRECEDING PAGE BLANK-NOT FILMED

**PROGRAM FUNDING EXPENDITURES
(MILLIONS)**

Organization	Projects	Authorized Funding	Contractor		In-House	
			Amount	Expended	Remaining	Expended
TECOM	4	\$ 3.3	\$ 0.2	\$*0.2 (84%)	\$ 3.0	\$ 1.6 (54%)
AVRADCOM	93	25.2	9.2	3.1 (33%)	16.1	2.9 (17%)
ARRADCOM/ARRCOM (Ammo)	229	133.1	54.3	31.9 (58%)	78.7	30.0 (38%)
ARRADCOM/ARRCOM (Weapons)	96	17.3	4.1	2.2 (54%)	13.3	3.9 (29%)
MERADCOM	21	6.4	4.1	2.1 (50%)	2.3	0.5 (21%)
CORADCOM	10	4.4	3.0	2.2 (71%)	1.4	0.2 (17%)
ERADCOM	48	28.1	16.9	11.3 (66%)	11.3	1.4 (12%)
AMMRC/DARCOM	13	20.7	6.0	4.9 (81%)	14.6	9.3 (63%)
NARADCOM	5	1.5	1.3	*0.5 (42%)	0.2	*0.2 (97%)
MICOM	74	29.0	14.8	8.8 (59%)	14.1	4.0 (28%)
TARADCOM/TARCOM	53	17.2	6.9	2.8 (40%)	10.3	1.2 (11%)
TOTAL	646	\$286.2	\$120.8	\$70.0 (58%)	\$165.3	\$55.2 (33%)

Figure 3

*All values rounded to one decimal place.

PRECEDING PAGE BLANK-NOT FILMED

MMT PROGRAM
PROJECT SLIPPAGE STUDY



PRECEDING PAGE BLANK-NOT FILLED

PROJECT SLIPPAGE STUDY

The purpose of this study is to monitor trends in the timeliness of the MMT Project execution. Figure 1 is a slippage profile for each command and for the program as a whole. This is the fourth time that this data has been presented in this format with the data now covering a period of approximately two years. No significant trends have developed during this time period. The only observations are that the projects with twelve months or less of projected slippage have dropped by three percentage points (from 72 to 69) and projects with 19-24 months of slippage have increased by four percentage points (from 6 to 10).

The IBEA detailed study of the project execution phase has been temporarily suspended, therefore additional information relating to the reasons for project slippage are difficult to ascertain. The previous comment stating that the twelve month average contract award time seems to be an important factor is still valid.

Another administrative problem affecting slippage is tardiness in submitting the final status report. Some project engineers are waiting for financial close-out to submit the final status report. This adds several months to the duration of the project. The final status report should be submitted when the technical work has been completed. This submission of a final status report has no effect on the fiscal close-out of a project.

PROJECT SLIPPAGE STUDY

COMMAND	NO. ACTIVE PROJECTS	PROJECT SLIPPAGE DISTRIBUTION (PERCENT)						
		NO DATA	0 MO	1-6 MO	7-12 MO	13-18 MO	19-24 MO	25+ MO
DARCOM	6		33			17	17	33
MERADCOM	21	14	33	24	19		10	
CORADCOM	10	20	10	10	10	10	20	20
ERADCOM	48	2	35	19	8	21	6	8
AMMRC	7	14	43	14			29	
NARADCOM	5		40				20	40
MICOM	74	22	22	19	14	9	9	5
TARADCOM-TARCOM	53	28	21	13	8	15	8	8
TECOM	4	25		50		25		
AVRADCOM	93	22	37	4	8	6	8	16
ARRADCOM-ARRCOM (AMM())	229	19	24	9	14	8	10	15
ARRADCOM-ARRCOM (WPNS)	96	30	11	18	10	5	10	15
	----	----	----	----	----	----	----	----
TOTALS (DARCOM WIDE)	646	20	25	13	11	9	10	13
PREVIOUS PERIOD TOTALS	563	17	30	13	12	10	6	12

Figure 1 - Slippage Profile

MMT PROGRAM
PROJECTS ADDED 2nd HALF, CY79



PRECEDING PAGE BLANK-NOT FILMED

PROJECTS ADDED IN 2ND HALF, CY79

DARCUM

D 80 5052

ARMY ENGINEERING DESIGN HANDBOOKS FOR PRODUCTION SUPPORT

TECHNICAL SCIENTIFIC AND ENGINEERING DATA IS CONTINALLY BEING GENERATED WITHIN THE ARMY AND NEEDS TO BE COLLECTED IN APPROPRIATE DOCUMENTS.

MERADCOM

E 80 3605

TRANSCALANT (HIGH POWER) TRANSISTOR

CURRENTLY AVAILABLE SOLID STATE POWER DEVICES OF REQUIRED RATINGS AND THEIR HEATSINKS OFTEN ARE TOO HEAVY AND BULKY TO BE CONVENIENTLY USED IN COMPACT LIGHTWEIGHT POWER CONDITIONERS.

E 80 3708

COATED FABRIC COLLAPSIBLE FUEL TANK PROGRAM - CIRCULAR SEAM

TO IMPROVE THE RELIABILITY AND ENDURANCE OF FABRIC PILLOW TANKS BY ELIMINATING THE LONGITUDINAL SEAMS WHICH ARE VULCANIZED TOGETHER, THESE SEAMS ARE THE MOST LIKELY CAUSE OF CATASTROPHIC FAILURE.

E 80 3709

CONTINUOUS LENGTH FUEL HOSE

PRESENT FUEL RESISTANT CONTINUOUS LENGTH HOSE IS MANDREL FABRICATION. FIFTY OR A HUNDRED FEET LENGTH OF HOSE IS FIRST MANDREL MADE AND THEN SECTIONS ARE SPLICED TOGETHER FOR THE DESIRED LENGTH. SPLICING IS LABOR INTENSIVE.

E 80 3716

PRODUCTION OF KOCITE (R) DERIVED ELECTRODES FOR FUEL CELLS

SIGNIFICANT REDUCTION IN FUEL CELL COSTS CAN BE REALIZED THROUGH REDUCTION IN NOBLE METAL CATALYST LOADINGS. ELECTRODES UTILIZING MINIMUM CATALYST LOADINGS ARE CURRENTLY PRODUCED IN SMALL BATCHES, SUBJECT TO VARIABILITY IN CHARACTERISTICS AND COST.

E 80 3717

HIGH TEMPERATURE TURBINE NOZZLE FOR 10 KW POWER UNIT

SUPER ALLOY METALS USED IN HOT COMPONENTS OF GAS TURBINES ARE LIMITED IN OPERATING TEMPERATURE AND ARE SUBJECT TO PREMATURE FAILURE IN DUSTY OR CORROSIVE ATMOSPHERE. ALLOY METALS ARE STRATEGIC MATERIALS AND ARE COSTLY TO MANUFACTURE.

PROJECTS ADDED IN 2ND HALF, CY79
(CONTINUED)

E 80 3747

LIGHTER, LACV-30, SKIRT AND FINGER COMPONENTS

FABRICATION OF SKIRT, FINGERS AND CONES IS CURRENTLY HIGHLY LABOR INTENSIVE, LEADING TO HIGH COMPONENT REPLACEMENT COSTS.

CORADCOM

F 80 3032

CONNECTOR TERMINATED STRIPE GEOMETRY INJECTION LASERS

NO PRODUCTION CAPABILITY EXISTS FOR PRODUCING THESE LASERS INTO CONNECTOR TERMINATED HERMETICALLY SEALED PACKAGES.

F 80 3036

CAD/CAM OF SPECIAL ELECTRONIC CIRCUITS

SEMICONDUCTOR INTEGRATED CIRCUITS NEEDED FOR SPECIAL COMMUNICATIONS EQUIP. MUST BE CUSTOM DESIGNED FOR EACH NEW APPLICATION. EACH IC REQUIRES SEVERAL MASK SETS AND A NUMBER OF IC ARE REQUIRED FOR EACH DEVICE. CONSIDERABLE ARTWORK IS REQUIRED.

F 79 9835

INTEGRATED THIN FILM TRANSISTOR DISPLAY

SEMICONDUCTOR DISPLAY ARRAYS REQUIRE COMPACT YET COMPLEX DRIVE CIRCUITS. A MULTI-STAGE VACUUM METALLIZING SYSTEM IS NEEDED.

ERADCOM

H 80 3009

10 MICRON WAVEGUIDE LASERS

LASERS CONSTRUCTED IN UNIT QUANTITIES ARE EXPENSIVE AND VARY IN CHARACTERISTICS. LASERS IN THE FUTURE WILL NEED PULSED AND CW CAPABILITIES

H 80 3010

MILLIMETER-WAVE SOURCES FOR 60, 94, AND 140 GHZ

TO ESTABLISH A MANUFACTURING CAPABILITY FOR PRODUCTION OF IMPATT DIODES WHICH ARE UNIFORM ENOUGH TO BE FIELD REPLACEABLE IN ARMY SYSTEMS.

PROJECTS ADDED IN 2ND HALF, CY79
(CONTINUED)

H 80 3012

INFRA-RED SOURCE FOR AN/ALQ-144

PRESENT INFRARED SOURCE FOR THE AN/ALQ-144 DOES NOT EMIT ENOUGH RADIATION IN BAND NO. 4.

H 80 3023

TUBULAR PLASMA PANEL

PRESENT DISPLAY DEVICE FOR TACFIRE AND TOS HAS TOO SMALL AN ACTIVE AREA, INSUFFICIENT INTERACTIVE AND MAP CAPABILITY. TUBULAR PLASMA PANEL CAN BE USED BUT IS HIGH IN COST DUE TO EXTENSIVE LABOR IN PARTS, INSP, ASSEMBLY, AND FINAL INSPECTION.

H 80 3026

HIGH PRESSURE OXIDE IC PROCESS

CONVENTIONAL OXIDATION OF THICK SILICON DIOXIDE LAYERS REQUIRES EXCESSIVE TIME OR TEMPERATURE. FOR OXIDE-ISOLATED BIPOLAR CIRCUITS, 1200 DEGREES FOR OVER 12 HOURS IS REQUIRED. FOR MOS/SOS, THE TEMPERATURES ARE EXCESSIVE.

H 80 3031

10.6 UM CO2 TEA LASERS

LASERS CONSTRUCTED IN UNIT QUANTITIES ARE EXPENSIVE AND VARY IN SPECIFICATIONS. PRESENT RANGE FINDER LASERS HAVE REDUCED ALL WEATHER CAPABILITIES AND ARE INEFFECTIVE AGAINST COUNTERMEASURE SMOKES.

H 80 3501

THIRD GENERATION PHOTOCATHODE ON FIBER OPTIC FACEPLATE

FORM, FIT AND FUNCTION REPLACEMENT OF 2ND GEN. 18 MM AND 25 MM DEVICES WITH 3RD GEN PRODUCT IMPROVEMENT WILL REQUIRE THAT A PRODUCTION TECHNIQUE BE AVAILIABLE FOR FABRICATING GA-AS PHOTOCATHODES ON FIBER OPTIC FACEPLATES.

H 80 3510

TRANSDUCER PROCESS TECHNOLOGY FOR MW DELAY LINES

THE PARAMETERS FOR DESCRIBING THE ACTUAL PROCESSES REQUIRED FOR HIGH-QUALITY TRANSDUCERS HAVE NOT BEEN DOCUMENTED. THIS RESULTS IN PRODUCTION HALTS AND LOW YIELD.

PROJECTS ADDED IN 2ND HALF, CY79
(CONTINUED)

H 80 9563

MINATURE HIGH VOLTAGE POWER SUPPLYS FOR NIGHT VISION GOGGLES

PRESENT IMAGE INTENSIFIER POWER SUPPLIES DO NOT MEET 3RD
GEN. SHAPE AND SIZE REQUIREMENTS.

H 80 9588

THIRD GENERATION LOW COST IMAGE INTENSIFIER TUBES

TYPICAL MANUFACTURING METHODS REQUIRE THE USE OF AN
EXCESSIVE AMOUNT OF HAND LABOR WHICH CONTRIBUTES TO HIGH
UNIT COSTS FOR THE INTENSIFIER TUBE.

H 79 9783

PRODUCTION OF HIGH RESISTIVITY SILICON MATERIAL

THERE IS NO DOMESTIC SOURCE OF ULTRA PURE SILICON. THE
DEPENDABILITY OF SUPPLY AT PRESENT IS UNRELIABLE.

H 80 9897

SURFACE ACOUSTIC WAVE RESONATOR + REFLECTIVE ARRAY DEVICES

PRODUCTION TECHNIQUES FOR ACHIEVING DEVICE REPRDUCIBILITY,
FREQUENCY TUNABILITY AND LOW COST FOR SAW RESONATORS AND
REFLECTIVE ARRAY DEVICES ARE NOT AVAILABLE.

AMMRC

M 80 6350

MATERIALS TESTING TECHNOLOGY

DESTRUCTIVE AND CERTAIN CONVENTIONAL NON-DESTRUCTIVE
TESTING TECHNIQUES ARE RESPECTIVELY UNSUITED AND INADEQUATE
OR HARD TO BE ADAPTED TO ON-LINE PRODUCTION TESTING USAGE.

M 80 6390

MMT PROGRAM IMPLEMENTATION AND INFORMATION TRANSFER

THE SUCCESS OF THE MMT PROGRAM IS VERY DEPENDENT ON WHETHER
THE RESULTS OF MMT WORK GET IMPLEMENTED. THIS IN TURN IS
DEPENDENT ON WHETHER INFORMATION CONCERNING THE MMT
TECHNOLOGY IS MADE AVAILABLE AND USED BY CONCERNED PARTIES.

NARADCOM

Q 79 8063

IMPROVED METHODS OF MFG OF BUTYL RUBBER HANDWEAR

THE PRESENT METHOD OF STANDARD BUTYL RUBBER GLOVE FUR ON
PROTECTION IS BY A SOLE SOURCE DIPPING PROCESS WHICH
REQUIRES CLOSE QUALITY AND ENVIRONMENTAL SUPERVISION
INCREASED COST AND LIMITED DURABILITY AND PROTECTION.

PROJECTS ADDED IN 2ND HALF, CY79
(CONTINUED)

Q 79 8066

CONTINUOUS FILAMENT HELMET PREFORM

CONVENTIONAL MODE OF MOLDING THE PASGT HELMET I.E. WEAVING KEVLAR YARNS INTO FABRIC CUTTING PREFORM AND LAYING UP, IS VERY WASTEFUL.

MICUM

R 80 1018

IMPROVED MFG. PROCESSES FOR DRY TUNED ACCELEROMETERS (CAM)

THERE IS A NEED TO ESTABLISH MANUFACTURING METHODS NECESSARY TO INCREASE YIELD AND REDUCE COST OF DRY TUNED ACCELEROMETERS. THE PRESENT METHOD IS LABOR INTENSIVE AND PRONE TO ERROR.

R 80 1021

COMPUTERIZED PROD PROCESS PLAN F/MACHINED CYLINDRICAL PARTS

MANUAL METHODS FOR PRODUCTION PROCESS PLANNING RESULT IN HIGH COSTS

R 80 1023

DIGITAL FAULT ISOLATION F/HYBRID MICROELECTRONIC MODULES

HYBRID MICROELECTRONIC MODULES REQUIRE-A SIGNIFICANT INCREASE IN DIGITAL FAULT ISOLATION CAPABILITY. INTERNAL PROBING IS OFTEN NECESSARY TO DIAGNOSE PROBLEMS

R 80 1024

MMT RADIO FREQUENCY STRIPLINE HYBRID COMPONENTS

THE TREND IN STRIPLINE TECHNOLOGY IS TO INTEGRATE WITHIN THE STRIPLINE ELEMENT DISCRETE COMPONENTS BOTH ACTIVE AND PASSIVE. TWO PROBLEMS NEED RESOLUTION - (1) NEED FOR EXTREME DIMENSIONAL ACCURACY, (2) COMPENSATION VARIABLE DIELECTIC THICKNESS.

R 80 1026

LOW COST MANUF TECH F/THE HIGH PROD OF MISSILE VANES

METAL CONTROL VANES, FINS AND MISSILE FAIRINGS CAUSE HIGH COST, WEIGHT PENALTIES AND LONG LEAD TIME

PROJECTS ADDED IN 2ND HALF, CY79
(CONTINUED)

- R 80 1030
AUTO TEST, MOUNTING, + STACKING OF LOCASERT

PRESENT METHODS OF MOUNTING AND TESTING PARTS USING
LOCASERTS ARE 10PCT HIGHER THAN THEY WOULD BE WITH
AUTOMATED METHODS.
- 3 80 3115
ENGINEERING FOR METROLOGY AND CALIBRATION

MEASUREMENT SCIENCES OR METROLOGY MUST BE CONTINUALLY
ADVANCED IN RELEVANT TECHNOLOGY AREAS TO KEEP PACE WITH
MANY ARMY PROGRAMS.
- R 80 3139
PROD METHODS F/MILLIMETER SEEK F/TERMINAL HOMING APPLICATION

LOW QUANTITY PRODUCTION IS TOO COSTLY FOR THE SYSTEM
REQUIREMENTS.
- R 80 3142
PRODUCTION METHODS F/LOW COST PAPER MOTOR COMPONENTS

HIGH VOLUME MISSILES AND ROCKETS USE HIGH STRENGTH TO
WEIGHT METAL MOTOR CASES WHICH ARE A COSTLY ITEM,
- R 80 3186
IMPROVED MFG PROCESSES FOR INFRARED INDIRECT FIRE SEEKERS

LOW YIELD OF SEEKER COMPONENTS IS DUE TO HANDLING AND
CHECKOUT OF GYRO OPTICS.
- R 80 3219
AUTOMATIC POLYMER ATTACHMENT PRODUCTION METHODS

PRESENT TECHNOLOGY EMPLOYS A POLYMER DISPENSING MACHINE
WHICH IS OPERATED MANUALLY, A TIME CONSUMING AND COSTLY
PROCESS.
- R 80 3254
LOW COST SEMI-FLEXIBLE THIN FILM SEMICONDUCTORS (CAM)

PRESENT CIRCUIT BOARDS LACK THE PACKING DENSITY AND
STRINGENT PACKAGING QUALITIES PROJECTED FOR FUTURE MISSILE
ELECTRONIC SYSTEMS.

PROJECTS ADDED IN 2ND HALF, CY79
(CONTINUED)

- R 80 3263
PRINTED WIRE BOARDS UTILIZING LEADLESS COMPONENTS

THE VOLUME, WEIGHT, QUANTITY, RELIABILITY AND COST OF PCB USING WIRE LEADS CAN BE SUBSTANTIALLY IMPROVED.
- R 80 3260
MANUFACTURING PARAMETERS FOR THERMAL BATTERIES

SLIGHT VARIATIONS IN MANUFACTURING PARAMETERS HAVE GREATLY MAGNIFIED EFFECT ON FINAL BATTERY PERFORMANCE AS A RESULT REJECTION RATES ARE HIGH.
- R 80 3294
PRODUCTION PROCESSES FOR ROTARY ROLL FORMING

MECHANICALLY JOINING OR WELDING A CONVENTIONAL CLOSURE TO COMMERCIAL TUBING IS EXPENSIVE.
- R 80 3396
INJECTION MOLDING OF LOW COST-ONE PIECE NOZZLES

ROCKET MOTORS AS ALTERNATIVES TO TUBE ARTILLERY ARE TOO COSTLY.
- R 80 3411
MFG OF NON PLANAR PRINTED CIRCUIT BOARDS

USE OF FLAT CIRCUIT BOARDS RESULTS IN COMPLEX AND EXPENSIVE INTERCONNECTIONS WITH LOWERED RELIABILITY.
- R 80 3435
SIMPLIFICATION OF HIGH-POWER THICK FILM HYBRIDS

THE PRESENT METHOD OF COOLING HIGH POWER HYBRID CIRCUITS INVOLVES A COMPLEX AND EXPENSIVE PROCEDURE USED ONLY ON LIMITED PRODUCTION ITEMS. USE OF A SINGLE BERYLLIA SUBSTRATE HAS BEEN DEMONSTRATED BUT NEEDS FURTHER DEVELOPMENT.
- R 80 3436
CERAMIC CIRCUIT BOARDS + LARGE AREA HYBRIDS

ADVANCED WEAPONS SYSTEMS NOW REQUIRE GREATER COMPLEXITY AND PACKAGING DENSITY THAN CAN BE PRODUCED BY CONVENTIONAL HYBRID TECHNOLOGY WITH SUITABLE COST AND RELIABILITY TRADEOFFS.

PROJECTS ADDED IN 2ND HALF, CY79
(CONTINUED)

R 80 3444

FULLY ADDITIVE MANUFACTURING FOR PRINTED WIRING BOARDS

THE PRESENT SUBTRACTIVE METHOD OF PRODUCING CIRCUIT BOARDS IS WASTEFULL OF COPPER SLOW AND EXPENSIVE.

R 80 3445

PRECISION MACHINING OF OPTICAL COMPONENTS

EXISTING PRECISION MACHINING FACILITIES CANNOT KEEP UP WITH THE DEMAND, MEET OPTICAL DESIGN REQUIREMENTS, MEET PRODUCTION SCHEDULES, AND STAY WITHIN REASONABLE COST BOUNDARIES.

TARADCOM

T 80 4264

TRACK INSERTS AND FILLERS FOR TRACK RUBBER PADS (PHASE II)

TRACK PADS CUT AND CHUNK IN ROCKY OR FROZEN GROUND RESULTING IN REDUCED PAD LIFE AND INCREASED COSTS AND MAINTENANCE.

T 80 4389

PROD OF FOLDABLE PLASTIC TOPS FOR SUFT TOP TRUCK CABS

CANVAS TOPS AND HACKS AFFORD MINIMUM COMFORT AND ENVIRONMENTAL PROTECTION. REPLACEMENT IS OFTEN NECESSARY.

T 80 4586

IMPROVED LARGE ARMOR STEEL CASTING (PHASE 2)

PRESENT CASTING TECHNIQUES NEED UPDATING IN ORDER TO EXPLOIT THE ADVANTAGE OF CASTING PROCESS.

T 80 5002

MFG METHODS FOR FABRICATING TORSION BAR SPRINGS FROM STEEL

ENGINEERING ALLOY STEELS CAN BE HEAT TREATED TO A MAXIMUM WORKING HARDNESS WHICH REQUIRES LARGE DIAMETER BARS THEREBY INTERFERING WITH DESIGN FITS AND INCREASING WEIGHT.

T 80 5006

PRODUCTION OF LIGHTWEIGHT STEEL CAST TRACK SHOES

THE MOST COSTLY ITEM TO MAINTAIN PER MILE OF TRACKED VEHICLE OPERATION IS THE TRACK.

PROJECTS ADDED IN 2ND HALF, CY79
(CONTINUED)

- T 80 5007
ADVANCED TECHNOLOGY BRAKE LINING MATERIALS (PHASE II)

BRAKE LINING MATERIALS ARE SUBJECT TO THERMAL SHOCK AND MECHANICAL WEAR AND MUST HAVE GOOD DAMPENING CAPACITY, THIS IS DIFFICULT TO ACHIEVE. WEAR SYSTEMS ARE SACRIFICED, CONTAMINATION BY FOREIGN SUBSTANCES CAUSES BRAKE FAILURE,
- T 80 5019
STORAGE BATTERY, LOW MAINTENANCE-PHASE III

THE MAJOR CAUSE OF TACTICAL VEHICLE BATTERY FAILURE IS BATTERY CONTAINER BREAKAGE,
- T 80 5045
SPALL SUPPRESSIVE ARMOR FOR COMBAT VEHICLES (PHASE II)

CURRENT METALLIC ARMOR DOES NOT SUPPRESS FLYING SHRAPNEL WITHIN THE VEHICLE CREW COMPARTMENT,
- T 80 5054
LASER SURFACE HARDENED COMBAT VEHICLE COMPONENTS (PHASE 2)

PRESENT METHODS OF SURFACE HARDENING INPUTS HEAT OVER LARGE SURFACE AREA,
- T 80 5067
PLASTIC BATTERY BOX (PHASE II)

METALLIC BATTERY BOXES ARE SUBJECT TO CORROSION, THEREBY, DAMAGING THE VEHICLE,
- T 80 5068
NEW ANTI-CORROSIVE MATERIALS AND TECHNIQUES (PHASE 1)

METALLIC COMPONENTS ARE DETERIORATED BY THE ENVIRONMENT,
- T 80 5075
MILITARY ELASTOMERS FOR TRACK VEHICLES (PHASE 1)

TRACK LIFE IS HELD AT ITS PRESENT LEVEL BY FAILURE OF RUBBER COMPONENTS SUCH AS BUSHINGS, PADS AND BLOCKS,
- T 80 5080
FABRICATION METHODS FOR ALUMINUM TRANSMISSION CASES

TRANS CASES ARE BULKY AND NEED COMPLEX FABRICATION AND MACHINING,

PROJECTS ADDED IN 2ND HALF, CY79
(CONTINUED)

T 80 5081

FABRICATION OF FRICTION RINGS AND REACTION PLATES

FAB OF FRICTION RINGS AND REACTION PLATES RESULTS IN LARGE AMOUNTS OF SCRAP MATERIAL THUS CONTRIBUTING TO HIGH COST,

T 80 5082

FLEXIBLE MACHINING SYSTEM, PILOT LINE FOR TCV COMPONENTS

PARTS FOR TRACKED COMBAT VEHICLES ARE TYPICALLY NOT MANUFACTURED IN LARGE QUANTITIES. BECAUSE OF THIS, MASS PDN TECHNOLOGIES THAT RESULT IN LOWER PDN COSTS ARE NOT USED.

T 80 5088

HIGH POWER ELECTRON BEAM WELDING IN AIR (PHASE 2)

USE OF ELECTRON BEAM HAS NOT BEEN EXPLOITED.

T 80 5090

IMPROVED AND COST EFFECTIVE MACHINING TECHNOLOGY (PHASE 2)

MACHINE DATA ON NEWER MATERIALS AND NEW REMOVAL RATES ARE NOT ESTABLISHED.

T 80 6000

LIGHT WEIGHT TILT-UP HOOD FENDER ASSEMBLY (PHASE II)

CURRENT HOOD/FENDER ASSEMBLY MADE FROM STEEL STAMPINGS ARE TOO HEAVY FOR ONE MAN TO LIFT.

T 80 6028

PRODUCTION QUALITY CONTROL BY AUTOMATED INSPECTION EQUIPMENT

THE INCREASED COMPLEXITY OF COMBAT VEHICLES HAS RESULTED IN EXCESSIVE TIME AND HIGH SKILL LEVEL REQUIREMENTS FOR INSPECTION AND TEST.

TECUM

O 80 5071

PRODUCTION TEST METHODOLOGY

ARTILLERY, VEHICLE AND ELECTRONIC CONVENTIONAL TEST CAPABILITIES NEED TO BE UPGRADED TO PROVIDE MORE TIMELY ACCURATE TEST DATA FOR THE TEST AND EVALUATION PROCESS.

PROJECTS ADDED IN 2ND HALF, CY79
(CONTINUED)

AVRADCOM

1 80 7052

ULTRASONICALLY-ASSISTED COLD FORMING OF TITANIUM NOSE CAPS

NOSE CAPS USED ON LEADING EDGE OF ROTOR BLADES ARE CURRENTLY BEING HOT FORMED, A TECHNIQUE WHICH REQUIRES LONG PROCESSING TIMES, COSTLY TOOLING, AND EXPENSIVE CHEMICAL ETCHING.

1 80 7113

COMPOSITE REAR FUSELAGE MANUFACTURING TECHNOLOGY

APPLICATION OF COMPOSITE MATERIALS TO AIRFRAME FUSELAGE COMPONENTS POSSESSES A LARGE POTENTIAL FOR COST AND WEIGHT SAVINGS. HOWEVER, PRODUCTION MANUFACTURING PROCESSES HAVE NOT BEEN ESTABLISHED FOR LARGE, FULL-SCALE, COMPOUND CURVATURE, COMPONENTS.

1 80 7119

NON-DESTRUCTIVE EVAL TECHNIQUES FOR COMPOSITE STRUCTURES

IMPLEMENTATION OF COMPOSITE STRUCTURES IN THE ARMY AIRCRAFT IS DEPENDANT UPON THE ABILITY TO DETECT AND EVALUATE DEFECTS.

1 80 7155

COST EFFECTIVE MANUFACTURING METHODS FOR HELICOPTER GEARS

DEMAND IN HELICOPTER OPERATION OF GREATER RELIABILITY OF HIGH PERFORMANCE GEARS AT LOWER COST HAS REQUIRED THAT IMPROVED PROCESSING AND EVALUATION TECHNIQUES BE INSTITUTED.

1 80 7183

SEMI-AUTO COMPOSITE MANUFAC SYSTEM HELICOPTER SECONDARY STRU

HELICOPTER FUSELAGE STRUCTURES HAVE HIGH MANUFACTURING COST DUE TO HIGH PART COUNT AND HIGH ASSEMBLY COSTS. METHODS OF COMPOSITE FABRICATION HAVE BEEN INVESTIGATED BUT HAND OPERATIONS RESULT IN HIGH LABOR COSTS.

1 80 7197

FARRICATION OF INTEGRAL ROTORS BY JOINING

CURRENT GAS TURBINE ROTORS ARE EITHER INTEGRALLY CAST OR THE BLADES AND DISKS ARE SEPARATE UNITS. THE BLISK CONCEPT DOES NOT PERMIT OPTIMUM MECHANICAL PROPERTIES OF THE UNIT AND THE OTHER METHOD REQUIRES COMPLEX AND EXPENSIVE MACHINING.

PROJECTS ADDED IN 2ND HALF, CY79
(CONTINUED)

- 1 80 7199
SURFACE HARDENING OF GEARS, BEARINGS AND SEALS BY LASERS

CASE CARBURIZING IS EXPENSIVE, REQUIRING MUCH ENERGY,
QUENCHING DIES, AND FINAL GRINDING.
- 1 80 7200
COMPOSITE ENGINE INLET PARTICLE SEPARATOR

CURRENTLY, FABRICATION OF THE T700 INLET PARTICLE SEPARATOR
(IPS) INVOLVES MACHINING OF CASTINGS AND FORGINGS AND THE
JOINING OF THESE PARTS BY WELDING AND BRAZING. THIS IS
COSTLY IN TERMS OF BOTH MATERIAL AND LABOR.
- 1 80 7202
APPLICATION OF THERMOPLASTICS TO HELICOPTER SECONDARY STRUCS

FORMING FIBER REINFORCED THERMOPLASTIC COMPONENTS INTO
COMPLEX, MULTI-CURVED STRUCTURAL CONFIGURATIONS, WITH
UNIFORM FIBER DISTRIBUTION, MINIMUM WARPAGE, AND ACCEPTABLE
DIMENSIONAL TOLERANCES HAS NOT BEEN ESTABLISHED FOR
AIRCRAFT COMPONENTS.
- 1 80 7240
MACHINING METHODS FOR ESR 4340 STEEL FOR HELICOPTER APPL.

MANY CRITICAL HELICOPTOR PARTS REQUIRE HIGH BALLISTIC
TOLERANCE CHARACTERISTICS. THESE COMPONENTS ARE BEING
FABRICATED FROM ESR 4340 STEEL. HOWEVER, THE MACHINING OF
THIS NEW MATERIAL IS NOT CLEARLY DEFINED AND, THEREFORE, IS
OVERLY EXPENSIVE.
- 1 80 7243
MACHINING OPERATIONS ON KEVLAR LAMINATED CONSTRUCTIONS

PRESENT METHODS OF MACHINING KEVLAR LAMINATES TEND TO CAUSE
DELAMINATION AND EXCESSIVE FUZZING OR FRAYING OF THE CUT
EDGES. THIS NECESSITATES THE USE OF TIME CONSUMING AND
REPETITIVE TECHNIQUES TO ACHIEVE ACCEPTABLE MACHINED
SURFACES.
- 1 80 7285
CAST TITANIUM COMPRESSOR IMPELLERS

CURRENT CENTRIUGAL COMPRESSOR IMPELLERS ARE FABRICATED BY
MACHINING THE FLOWPATH AND BLADE SURFACES FROM A FORGING.
THIS RESULTS IN A SUBSTANTIAL LOSS OF MATERIAL AND
EXPENSIVE MACHINING OPERATIONS.

PROJECTS ADDED IN 2ND HALF, CY79
(CONTINUED)

- 1 80 7286
HIGH QUALITY SUPERALLOY POWDER PRODUCTION FOR TURB. COMP.
WITH THE COMMITMENT OF GAS TURBINE ENGINE MANUFACTURERS TO THE PRODUCTION OF ENGINE HARDWARE FROM SUPER-ALLOY POWDER THE NEED TO IMPROVE POWDER CLEANLINESS HAS BEEN RECOGNIZED.
- 1 80 7288
DETERMINATION OF OPTIMAL CURING CONDITIONS FOR COMPOSITES
CURRENT METHODS OF CURING COMPOSITES ARE BASED ON EMPIRICAL DETERMINATION OF REQUIRED PROCESSING CONDITIONS. A TRIAL AND ERROR PROCEDURE IS FOLLOWED UNTIL THE MANUFACTURER IS REASONABLY SATISFIED WITH MECHANICAL PROPERTIES.
- 1 80 7291
TITANIUM POWDER METAL COMPRESSOR IMPELLER
WHEN COMPLEX CONFIGURATIONS, SUCH AS CENTRIFUGAL IMPELLERS AND COMPRESSOR ROTORS ARE UTILIZED IN GAS TURBINE ENGINES, TYPICALLY HIGH MANUFACTURING COST ARE ENCOUNTERED.
- 1 80 7292
MICROPROCESSOR AND LSI FAULT ISOLATION AND TESTING
TESTING OF CPU CARDS INTERMITTENT MICROPROCESSOR PART FAILURES ARE MOST DIFFICULT PROBLEMS TO SOLVE. STD AUTOMATIC TEST EQPT BECOMES INEFFICIENT, OR UNPREGNABLE, WHEN CMPLX INTEGRATED CKTS ARE PORTIONS OF THE PRINTED CKT CARD TESTED.
- 1 80 7298
HIGH TEMPERATURE VACUUM CARBURIZING
GEAR CARBURIZING IS PRESENTLY CARRIED OUT WITH A RELATIVELY SLOW ENDOTHERMIC PROCESS, TYPICALLY AT 1700 DEG F, WHICH REQUIRES SURFACE PROTECTION AGAINST DECARBURIZING DURING THE CYCLE OR A POST HEAT TREAT REMOVAL OF THE DECARBURIZED LAYER.
- 1 80 7338
COMPOSITE TAIL SECTION
THE POTENTIAL COST AND WEIGHT ADVANTAGES OF COMPOSITES FOR AIRFRAME COMPONENTS HAVE NOT BEEN FULLY DEMONSTRATED DUE TO FABRICATION LIMITATIONS RELATED TO CONFIGURATION RESTRAINTS, FOR EXAMPLE, IN-PLACE WINDING, COMPLEX CONTOURS, AND CO-CURING.

PROJECTS ADDED IN 2ND HALF, CY79
(CONTINUED)

1 80 7339

FILAMENT WOUND COMPOSITE FLEXBEAM TAIL ROTOR

FILAMENT WINDING FROM A SOLID FLEXBEAM TO AN OPEN SPAR SECTION, WINDING TO NET SHAPE, IMPROVED RESIN CONTROL AND TOLERANCE CONTROL MUST BE OBTAINED TO ENHANCE THE COST EFFECTIVENESS OF FLEXBEAM TAIL ROTORS.

1 80 7340

COMPOSITE MAIN ROTOR BLADE

CURRENT PRODUCTION COMPOSITE BLADE PROGRAMS HAVE NOT BEEN ORIENTED TOWARD OPTIMIZING MANUFACTURING TECHNIQUES/PROCESSES RELATED TO BLADE CONFIGURATIONS, FABRICATION METHODS, AND IMPROVED STRUCTURAL RELIABILITY.

1 80 7341

STRUCTURAL COMPOSITES FABRICATION GUIDE

THE NEED EXISTS TO DOCUMENT INDUSTRY EXPERIENCE IN COMPOSITES SO THAT COST AND MANUFACTURING COMPARISONS CAN BE MADE.

1 80 7342

PULTRUSION OF HONEYCOMB SANDWICH PANELS

FABRICATION OF HONEYCOMB SANDWICH PANELS IS LABOR INTENSIVE AND FACE-TO-CORE BONDING OFTEN TAKES TWO CURE OPERATIONS. PULTRUSION CAN BE USED FOR CONTINUOUS PRODUCTION BUT COMMERCIAL PARAMETERS AND TOOLING ARE NOT SUITABLE FOR MILITARY USE.

1 79 7371

INTEGRATED BLADE INSPECTION SYSTEM (IBIS)

INSPECTION OF TURBINE ENGINE BLADES AND VANES NECESSITATES HIGH ACCURACY. THE EFFORT IS TIME CONSUMING AND SUSCEPTIBLE TO ERROR.

ARRAUCOM-ARRCOM (AMMO)

5 80 0900

AUTOMATED MULTIPLE FILTER LIFE TESTER

THERE IS A LOW TEST RATE CAPACITY AND AN INCREASING VOLUME OF TESTING FOR THE CURRENT FILTER LIFE TEST EQUIPMENT

PROJECTS ADDED IN 2ND HALF, CY79
(CONTINUED)

5 80 1001

PILOT LINE FOR FUZE FLUIDIC POWER SUPPLIES

FLUIDIC GENERATORS ARE COMPLEX AND COSTLY TO PRODUCE. IN PRODUCTION, CLOSE TOLERANCES AND SMALL PART ASSEMBLY ARE REFLECTED IN HIGH COST AND LOW YIELD.

5 80 1003

LOW COST MOLDED PACKAGING FOR HYBRID ELECTRONICS

FOAM OR EPOXY POTTED HYBRID CIRCUITS USED IN SMALL CALIBER ARE NOT SURVIVING HI G LEVELS. HERMETIC PACKAGES ARE NOT USED DUE TO COST CONSIDERATIONS.

5 80 1005

CERAMIC-METAL SUBSTRATES FOR HYBRID ELECTRONICS

ALL THICK FILM HYBRIDS ARE FABRICATED ON A CERAMIC SUBSTRATE WHICH IS FRAGILE AT HIGH G SHOCK LEVELS AND MUST BE ADEQUATELY SUPPORTED IN ORDER TO SURVIVE. THIS IS A COSTLY PROCEDURE.

5 80 1296

MANUFACTURING TECHNOLOGY FOR CB FILTERS

EXISTING FILTER PRODUCTION FACILITIES ARE OBSOLETE, INEFFICIENT AND EXPENSIVE TO OPERATE.

5 80 1318

EST CHEMICAL PROD + FILL CLOSE + LAPT TECH F/PROJ 811 VX-2

THE QL PROCESS FOR VX BINARY MFG RESULTS IN LARGE QUANTITIES OF PASTE, AND ORGANIC PHOSPHOROUS COMPOUNDS. PRIOR PROCEDURES FOR DISPOSAL (DEEP WELL) ARE NO LONGER ACCEPTABLE. NEW TECHNIQUES ARE REQUIRED.

5 80 1345

BIOLOGICAL WARNING SYSTEM

THERE IS NO BIOLOGICAL AGENT DETECTOR MASS PRODUCTION CAPABILITY.

5 80 1348

SUPER TROPICAL BLEACH

THERE IS A MAJOR SHORTFALL BETWEEN THE FY78 REQUIREMENTS FOR THIS ITEM AND THE QUANTITY OF IMPORTED CHLORINATED LIME KNOWN TO BE AVAILABLE.

PROJECTS ADDED IN 2ND HALF, CY79
(CONTINUED)

5 80 1354

SLUDGE VOLUME REDUCTION AND DISPOSAL PROCESS STUDY

MCA POLLUTION ABATEMENT FACILITIES UNDER CONSTRUCTION AT PINE BLUFF ARSENAL DISCHARGE INTO A SETTLING LAGOON HAVING A FIVE YEAR CAPACITY BUT NO CLEAN OUT OR SLUDGE DISPOSAL EQUIPMENT. TO EXTEND LAGOON LIFE-SPAN, SLUDGE VOLUME MUST BE MINIMIZED.

5 80 1355

MANUFACTURING PLANTS TOXIC EFFLUENT/EMISSION PRETREATMENT

THE POLLUTANT DISCHARGE PERMIT PROGRAM REQUIRES THE USE OF BEST AVAILABLE TECHNOLOGY FOR THE TREATMENT OF DESIGNATED TOXIC WASTES BY 1984. PINE BLUFF ARSENAL WASTE TREATMENT FACILITY DOES NOT EMPLOY BEST AVAIL. TECH. FOR THESE POLLUTANTS.

5 80 1902

MFG METHODS OF GEL FUEL FOR FAE BOMBS BLU-95/B AND BLU-96/B

A PROCESS TO PRODUCE LARGE QUANTITIES OF THIXOTROPIC FUEL CONTAINING PROPYLENE OXIDE DOES NOT EXIST. THE FUEL, DUE TO ITS FLAMMABLE AND THIXOTROPIC PROPERTIES, PRESENTS MAJOR PROBLEMS IN THE AREAS OF MIXING, STORAGE, PUMPING, AND LOADING.

5 80 1903

DIE CAST TAIL CONE + DESIGN MACHINE FOR BLU-96/B

CURRENT ROLL FORMING EQUIPMENT IS LIMITED TO SIX FEET. BLU-96/B SKIN IS TEN FEET AND IS GROOVED. LIMITED EXPERIENCE EXISTS IN BUILDING A DIE FOR THE BLU-96/B TAILCONE WHICH IS 26 INCHES IN DIAMETER AND WEIGHS IN EXCESS OF 70 LBS.

5 80 3961

IMPR (3-0) VIB ACCEPT TSTNG F ART FUZES AND S/A MECHANISMS

CURRENT METHODS ARE COSTLY AND TIME CONSUMING, RARELY EXPOSE THE TEST ITEM TO TRUE SERVICE ENVIRONMENTS, AND REQUIRE THREE TESTS TO ACCOUNT FOR ALL TEST AXES.

5 80 4000

AUTOMATED M55 DETONATOR PRODUCTION EQUIPMENT

LAP OF DETONATORS IS LABOR INTENSIVE. PERSONNEL EXPOSURE IS EXTENSIVE. M08 RATES ARE EXTREMELY HIGH.

PROJECTS ADDED IN 2ND HALF, CY79
(CONTINUED)

- 5 80 4027
COMBINED SOLVENT RECOVERY/DRYING OF S-8 PROPELLANT

PRESENTLY SOLVENT RECOVERY, WATER DRY, AND AIR DRY OPERATIONS ARE ACCOMPLISHED IN 3 SEPARATE TANKS, ONE TANK IS USED FOR EACH OPERATION. THESE OPERATIONS ARE BOTH LABOR AND ENERGY INTENSIVE AND GENERALLY INEFFICIENT.
- 5 80 4033
CAUSTIC RECOVERY FROM SODIUM NITRATE SLUDGE

MOLSTON IS CURRENTLY LOSING \$80 FOR EACH TON OF SODIUM NITRATE BY-PRODUCT SOLD. SODIUM NITRATE IS EXTREMELY DIFFICULT TO DISPOSE OF BECAUSE OF COMPETITION FROM OTHER FERTILIZERS ON THE MARKET.
- 5 80 4037
PROCESS IMPROVEMENT FOR PLASTIC-BONDED EXPLOSIVES

PRESENT METHODS OF PRODUCING PBX COMPOSITIONS ARE JOB-SHOP ORIENTED AND UNECONOMICAL FOR LARGE SCALE PRODUCTION PROJECTED IN THE FUTURE.
- 5 80 4061
NITROGUANIDINE PROCESS OPTIMIZATION

A NITROGUANIDINE FACILITY IS UNDER CONSTRUCTION AT SAAP AND IS TO BE OPERATIONAL IN FY80, IT UTILIZES PROCESSES NOT PREVIOUSLY USED COMMERCIALY AND IT CONTAINS MANY RECIRCULATION AND SUPPORT LOOPS, THE OPERATION OF WHICH ARE STRONGLY INTERDEPENDENT.
- 5 80 4062
AUTO MANUFACTURE SYS F/MORTAR INCREMENT CONTAINERS

THE MANUFACTURE AND ASSEMBLY OF THE 60/81MM PROP CHARGE INCREMENT CONTAINER IS LABOR INTENSIVE AND DOES NOT MEET PRODUCTION REQUIREMENTS.
- 5 80 4071
EXPLOSIVE DUST HAZARDS IN MUNITIONS PLANTS

POTENTIALLY HAZARDOUS CONDITIONS EXIST IN DRY DUST COLLECTION SYSTEMS THROUGHOUT THE MUNITIONS PRODUCTION BASE. PRESENT DATA ON DETONATION CHARACTERISTICS OF EXPLOSIVE, PROPELLANT OR PYROTECHNIC DUST ARE INCOMPLETE/INADEQUATE TO IMPROVE SAFETY.

PROJECTS ADDED IN 2ND HALF, CY79
(CONTINUED)

5 80 4084

OPACITY/MASS EMISSION CORRELATION

FURGING OPERATIONS FOR LARGE CALIBER AMMUNITION PRODUCE SMOKE THAT IS REGULATED FOR BOTH OPACITY AND MASS OF THE EMISSIONS.

5 80 4086

REPROCESSING EXPLOSIVE FINES AND DRILL SCRAP

FINELY DIVIDED EXPLOSIVE SCRAP GENERATED IN CAVITY DRILLING AND RISER CRUSHING OPERATIONS IS CURRENTLY BURNED AS WASTE. IT CANNOT BE REPROCESSED IN ITS GENERATED STATE DUE TO HANDLING PROBLEMS AND AGGLOMERATION WHEN INTRODUCED INTO MELT SYSTEMS.

5 80 4131

SHELL HOLOGRAPHIC INSPECTION AND EXAMINATION LINE DEVICE

THERE IS NO COMPLETE AUTOMATIC NONDESTRUCTIVE INSPECTION SYSTEM FOR TESTING SHELLS AT 100 PERCENT PRODUCTION RATE.

5 80 4137

AUTOMATED LOADING OF CENTER CORE IGNITERS

LOADING OF THE LONG SLENDER CLOTH BAG IS AN AREA WHICH REQUIRES HIGH LABOR COSTS AND SUBJECTS A LARGE NUMBER OF PERSONNEL TO HAZARDOUS OPERATIONS.

5 79 4150

NEW MANUFACTURING PROCESSES FOR SMALL CALIBER PENETRATORS

MANUFACTURE OF PENETRATORS INTO BALL BULLETS IS VERY COSTLY.

5 80 4150

NEW MANUFACTURING PROCESSES FOR SAWS AMMUNITION

MANUFACTURE OF PENETRATORS INTO BALL BULLETS IS VERY COSTLY.

5 80 4182

PROCESS IMPROVEMENTS AND AUTO TEST FOR RAAM, GEMSS, GATOR

NO EQUIPMENT EXISTS TO TEST MAGNETOMETER CORES, AUTOMATE MAGNETIC COUPLING DEVICE. PC BOARD WARPING OCCURS DURING WAVE SOLDERING. NO DIAGNOSTIC TESTER EXIST FOR FAMILY OF SCATTERABLE MINE ELECTRONIC LENS.

PROJECTS ADDED IN 2ND HALF, CY79
(CONTINUED)

- 5 80 4189
HIGH FRAGMENTATION STEEL PRODUCTION PROCESS
THE CURRENT PRODUCTION PROCESS FOR MANUFACTURING HF1 PROJECTILES IS EXTREMELY EXPENSIVE. PROPRIETARY PRODUCTION PROCESSES DEVELOPED BY PRIVATE INDUSTRY ARE NOT AVAILABLE.
- 5 80 4200
TNT CRYSTALLIZER FOR LARGE CALIBER MUNITIONS
TNT MELT LOADING REQUIRES AN OPTIMUM RATIO OF MOLTEN AND SOLID TNT IN THE EXPLOSIVE MIX AT THE TIME OF POUR. THE RATIO IS OBTAINED BY THE ADDITION OF FLAKE TNT TO A QUANTITY OF MOLTEN TNT BASED ON OPERATOR JUDGEMENT.
- 5 80 4210
DRY CUTTING OF ENERGETIC MATERIALS
BENITE STRANDS ARE CUT TO REQUIRED LENGTHS USING A MILLING MACHINE WITH TWO CIRCULAR SAWS. THIS IS UNDULY COSTLY BECAUSE OF EXCESSIVE HANDLING, AND ADDITIONAL DRYING AND INSPECTION OPERATIONS.
- 5 80 4225
RED WATER POLLUTION ABATEMENT SYSTEM
RED WATER PRODUCED IN VOLUME FROM THE PURIFICATION OF TNT IS A POLLUTANT FOR WHICH A SATISFACTORY DISPOSAL METHOD DOES NOT EXIST.
- 5 80 4226
ON-LINE MONITORS FOR WATER POLLUTANTS
AAP'S DISCHARGE MANY MILITARY UNIQUE POLLUTANTS THAT THE SURGEON GENERAL HAS FOUND TO BE MORE TOXIC THAN EXPECTED. AMENDMENTS TO 1977 WATER POLLUTION CONTROL ACT STIPULATE THAT ALL POLLUTANTS BE MONITORED.
- 5 80 4231
IN-PLANT REUSE OF POLLUTION ABATED WATERS
MORE STRINGENT STANDARDS FOR MILITARY UNIQUE POLLUTANTS. 1985 GOAL OF ZERO DISCHARGE. EXPENSE OF TREATING POLLUTION. CONTINUE THIS REUSE OF TREATED WATER IN OTHER PROCESSES.
- 5 80 4236
AUTO LACE JACKETS FOR CENTER CORE CHARGES
THE MANUAL THREADING AND TIGHTENING OF THE LACING IS EXTREMELY TIME CONSUMING AND REQUIRES LABOROUS HIGH COST OPERATIONS WHILE PROVIDING POOR QUALITY PRODUCT.

PROJECTS ADDED IN 2ND HALF, CY79
(CONTINUED)

- 5 80 4253
AUTO HIGH-RATE UNPACK EQUIP FOR MORTAR PROP CHGS

HANDPACKING ON THE MORTAR PROP CHGS M204 AND 205 LAP LINE
RESULTS IN UNSAFE CONDITIONS AND DAMAGE TO PARTS.
- 5 80 4266
MFG, IHSP AND TEST EQUIPMENT FOR MAGNETIC POWER SUPPLY

PIEZOELECTRIC POWER SUPPLIES USED IN HEAT AMMO HAVE BEEN
OBSERVED TO HAVE UNDESIRABLE VOLTAGE GENERATION IMPRESSED
ON THE ELECTRICAL CIRCUITING OF THE ROUND DUE TO SHOCK
VIBRATIONS RESULTING DURING FLIGHT WHICH MAY CAUSE
PREMATURES.
- 5 80 4274
RECOV + REGEN OF PROPL MFG SOLVENTS BY AUTO CONTROL

ACTIVATED CHARCOAL SOLVENT RECOVERY SYSTEMS OPERATE ON
TIMED CYCLE OPEN LOOP CONTROLLED BASIS. CYCLES ESTABLISHED
BY CALCULATIONS. SOLVENT CONTENT OF AIR PASSED THRU BEDS
VARIES WIDELY. RESULTS IN INEFFICIENT SOLVENT RECOVERY
UNNECESSARY ENERGY USAGE
- 5 80 4281
CONSERVATION OF ENERGY AT ARMY AMMUNITION PLANTS

PETROLEUM MAY NOT BE AVAILABLE IN FUTURE TO MEET PRODUCTION
REQUIREMENTS.
- 5 80 4285
TNT EQUIVALENCY TESTING FOR SAFETY ENGINEERING

PRESENT CRITERIA FOR BLAST RESISTANT STRUCTURES IS IN TERMS
OF SURFACE BURST OF HEMISPHERICAL TNT. IN STRUCTURAL
DESIGN, TO PROTECT FROM THE OUTPUT OF OTHER ENERGETICS, THE
DESIGNERS MUST HAVE DATA PERTINENT TO THE MATERIAL IN
QUESTION.
- 5 80 4288
EXPLOSIVE SAFE SEPARATION AND SENSITIVITY CRITERIA

DATA IS REQUIRED TO UPGRADE PROCESSES AND MATERIAL FOR THE
MAXIMUM SAFETY OF PERSONNEL AND EQUIPMENT AGAINST EXPLOSION
PROPAGATION.

PROJECTS ADDED IN 2ND HALF, CY79
(CONTINUED)

5 80 4291

BLAST EFFECT IN THE MUNITION PLANT ENVIRONMENT

MOST OF THE DESIGN EFFORT IS IN THE AREA OF LACE REINFORCED STRUCTURES FOR CLOSED IN AREAS TO AN EXPLOSION. WE MUST ATTEMPT TO UTILIZE COM CONSTRUCTION MATERIAL.

5 80 4298

EVALUATION OF HEXAMINE RECYCLE ON HAAP B-LINE

HAAP'S AMMONIA COLUMN (B-LINE) EFFLUENT CONTAINS HEXAMINE WHICH IS NOT READILY BIODEGRADABLE NOR CHEMICAL DECOMPOSABLE. HEXAMINE IS ALSO CARCINOGENIC USE OF WET OXIDATION IN HAAP'S NEW LWTF WOULD BE QUITE EXPENSIVE TO BUILD AND OPERATE.

5 80 4309

PROPELLANT PROCESS DEVELOPMENT FOR 120MM TANK AMMUNITION

MASS PRODUCTION IN THE US OF W. GERMAN 120MM TANK AMMUNITION POSES PROBLEMS IN FOUR FUNCTIONAL AREAS - METAL PARTS, PROPELLANT, FUZE, AND LAP.

5 80 4310

DMSO RECRYSTALLIZATION OF RDX/HMX

THE CURRENT METHOD OF RECRYSTALLIZING HMX/RDX IS INEFFICIENT AND UNECONOMICAL. IT REQUIRES LARGE AMOUNTS OF RAW MATERIALS (ESP CYCLOHEXANONE OR ACETONE), PROCESS VESSELS, AND MANPOWER.

5 80 4312

INJECTION MOLDING FOR PRODUCTION EXPLOSIVE LOADING

MELT LOADING OF SMALL EXPLOSIVE ITEMS NORMALLY REQUIRES LARGE SURPLUSES OF MOLTEN EXPLOSIVE TO OBTAIN GOOD FILLING CHAR. SURPLUS RISER MATERIAL CAN BE TWICE THE AMOUNT LOADED INTO END ITEMS. VERY SMALL ITEMS CANNOT BE EFFECTIVELY MELT LOADED AT ALL.

5 80 4322

CHARACTERIZE DORMANCY EFFECT ON ELECTRONIC EQUIPMENT

UNCERTAINTY OF THE EFFECT OF LONG TERM STORAGE DURING PLANT LAYAWAY ON ELECTRONIC CONTROL SYSTEMS AND THE ASSOCIATED IMPACT ON PRODUCTION BASE LEAD TIME.

PROJECTS ADDED IN 2ND HALF, CY79
(CONTINUED)

5 80 4341

IMPROVED NITROCELLULOSE PURIFICATION PROCESS

EXISTING NITROCELLULOSE PURIFICATION FACILITIES WERE BUILT IN EARLY 1940'S AND ARE IN DETERIORATED CONDITION. THE PROCESS USED DATES BACK TO WWI AND CONSUMES LARGE QUANTITIES OF ENERGY AND WATER.

5 80 4344

ESTAB OF WASTE DISPOSAL TECH FOR M687 BINARY PROJECT

LARGE QUANTITIES OF SOLID WASTES ARE GENERATED DURING DF MFG. THERE IS NO ACCEPTABLE DISPOSAL METHOD. DRUM STORAGE IS NOT FEASIBLE AND LANDFILL MAY REQUIRE SPECIAL PREPARATION.

5 80 4405

ULTRASONIC TEST EQUIPMENT FOR 155MM XM795

PREVIOUSLY, METAL PARTS CONTRACT WAS USED AS THE VEHICLE FOR DEVELOPMENT AND FABRICATION OF ULTRASONIC TEST EQUIPMENT. THIS APPROACH HAS PROVEN UNSATISFACTORY AS IT IS NOT TIMELY WITH REGARD TO SUPPORTING PRODUCTION SCHEDULES.

5 80 4454

AUTO INSP DEVICE EXPLOS CHARGE SHELL (AIDECs)

THE PRESENT METHOD OF INSPECTION LOADED PROJECTILE UTILIZES A STANDARD RADIOGRAPHIC FILM METHOD. LABOR AND MATERIAL (FILM) ARE COSTLY. DETERMINATION OF CRITICAL DEFECT IS SUBJECT TO HUMAN JUDGEMENT, FATIGUE, AND ERROR.

5 80 4462

FORCED AIR DRY FOR MULTI-BASED PROPELLANTS

FORCED AIR DRYING PROCESS AND FACILITIES MUST BE MODIFIED TO REDUCE THE POLLUTION EMISSIONS AND AT THE SAME TIME RECOVER VALUABLE PROPELLANT MATERIAL.

5 80 4469

AUTOMATIC INSERTION OF GRENADE LAYERS

THE MANUAL INSERTION GRENADE LAYERS INTO PROJECTILES IS A HIGHLY MANUAL, COSTLY AND HAZARDOUS OPERATION.

5 80 4498

DEV METH FOR CONSOL AND AUTO ASSY OF SMALL MINES

OFF-LINE OPERATIONS AND MULTIPLE HANDLING IS REQUIRED FOR THE PREDOMINATELY MANUAL LAP OPERATIONS.

PROJECTS ADDED IN 2ND HALF, CY79
(CONTINUED)

5 80 4508

PROCESS IMPROVEMENT OF PRESSABLE ROX COMPOSITIONS

HSAAP IS HINDERED WITH PROCESS BOTTLENECKS IN MANUFACTURING A COMPS. PROCESSING USES JOB SHOP TECHNIQUES AND IS LABOR INTENSIVE. OVERALL PRODUCTION FACILITIES ARE SEVERELY CONSTRAINED AND OPERATE UNDER SAFETY WAIVERS DUE TO OUTDATED TECHNOLOGY USED.

5 80 6736

TECH READINESS ACCEL THRU COMPUTER INTEGRATED MFG (CAM)

THE LEAD TIME REQUIRED TO BRING PRODUCTION LINES TO MOBILIZATION MAXIMUM IS INTOLERABLY EXCESSIVE. A CRITICAL DETERRENT IS THE EXTREME SHORTAGE OF TOOLMAKERS AND MACHINISTS.

5 80 6738

ULTRA-HIGH SPEED METAL REMOVAL, ARTILLERY SHELL

DUE TO THE LOW METAL REMOVAL RATES OF THE CURRENT CONVENTIONAL MACHINING OPERATIONS, A GREATER NUMBER OF MACHINES ARE REQUIRED TO PRODUCE ARTILLERY PROJECTILES.

ARRADCOM-ARRCOM (WPNS)

6 80 3901

MANUFACTURE OF FLUIDIC AMPLIFIERS BY COLD FORMING (PHASE 2)

PRESENT METHODS OF MANUFACTURING FLUIDIC AMPLIFIERS ARE COSTLY AS THEY REQUIRE 100 PER CT INSPECTION BECAUSE OF UNSATISFACTORY REPEATABILITY IN DIMENSIONS AND FINISHES.

6 80 7605

CHEMICALLY BONDED SAND FOR CLOSE TOLERANCE CASTING

PRESENT METHODS OF MOLDING AND CORE MAKING ARE COSTLY, ENERGY WASTEFUL, AND UNSUITABLE FOR HOLDING CLOSE TOLERANCES.

6 80 7730

MANUFACTURE OF SPLIT RING BREECH SEALS

SPLIT RINGS REQUIRE PRECISE MFG. PRESENT METHODS ARE OUTDATED AND COSTLY REQUIRING MUCH HAND FINISHING BY HIGHLY SKILLED WORKERS. REJECTION RATE HIGH WITH MUCH REWORK.

PROJECTS ADDED IN 2ND HALF, CY79
(CONTINUED)

6 80 7920

CONSERVATION OF CRITICAL MATERIALS FOR GUN TUBES

GUN STEEL REQUIRES ALLOY SUCH AS CHROMIUM WHICH IS BECOMING IN SHORT SUPPLY AND WHICH MUST BE OBTAINED FROM OUT OF COUNTRY AND FROM A RELATIVELY FEW NATIONS. THERE IS A NEED FOR MATERIALS AND PROCESSES WHICH USE LESS OF CRITICAL ELM SUCH AS CHROMIUM.

6 80 7925

BORE EVACUATOR BORING

BOTH ENDS OF THE BORE EVACUATOR HAVE SIMILAR DIAMETER BORES AND REQUIRE ALMOST EQUAL MACHINING WITH HIGH COST OF MACHINING TIME. REDUCTION OF MACHINING TIME IS IMPERATIVE. ORIENTATION OF THE BORES IS IN RELATION TO EACH OTHER.

6 80 7926

HOT ISOSTATIC PRESSING OF LARGE ORDNANCE COMPONENTS

MANY HOURS ARE REQUIRED TO MACHINE THE BREECH BLOCK FORGING TO THE FINISHED PART. MORE THAN 25% OF FORGING BECOMES CHIPS. WITH HIGH COST OF ALLOY STEEL, THIS BECOMES A VERY COSTLY WASTE OF MATERIAL.

6 80 7927

GENERATION OF BASE MACHINING SURFACES

TO OBTAIN A DISTR OF STOCK ON A ROUGH CAST COMPONENT, IT IS CURRENTLY NECESSARY TO 'DRAW' THE FINISHED COMPONENT ON THE MATERIAL USING HT GAGE AND LAYOUT TEMPLATES. THIS IS DONE ON A TABLE FROM WHICH THE PART MOVES TO A MACHINE FOR SIMILAR SET-UP.

6 80 7948

ESTABLISH CUTTING FLUID CONTROL SYSTEM

THE LACK OF A CONTROLLED PROGRAM FOR THE USE OF CUTTING FLUIDS RESULTS IN HIGH MACHINING COSTS AND STOCKING OF MANY FLUIDS.

6 80 7949

APPLICATION OF GROUP TECHNOLOGY TO RIA MFG (CAM)

PRESENT PLANNING, SCHEDULING, AND MANUFACTURE OF WEAPON ASSEMBLIES AND COMPONENTS ARE BY SEPARATE LOTS AND PARTS WHICH REQUIRE MULTIPLE, MACHINING OPERATIONS, SET-UPS AND CHANGES OF TOOLING, AND CAUSE LOSS OF TIME AND MONEY.

PROJECTS ADDED IN 2ND HALF, CY79
(CONTINUED)

6 80 7963

GROUP TECHNOLOGY FOR FIRE CONTROL PARTS AND ASSEMBLIES

FIRE CONTROL MANUFACTURING HAS RESULTED IN THE PROLIFERATION OF MANUFACTURING INFORMATION, LONG SET-UP TIMES OR MULTIPLE RESETTING OF MACHINES, UNDER-UTILIZATION OF MACHINES, LONG AND UNCERTAIN THROUGHPUT TIMES, AND HIGH WORK-IN-PROGRESS.

6 80 7985

SMALL ARMS WEAPONS NEW PROCESSES PRODUCTION TECHNOLOGY

GUN BARREL MFG PROCEDURES REFLECT ANTIQUATED TECHNOLOGY AND RELY ON MASS REMOVAL OF MATERIAL BY CONVENTIONAL MACHINING METHODS. CURRENT EQUIP REPRESENTS 1940-50 TECHNOLOGY. NEW MATERIALS COMPOUND THE PROBLEM.

6 79 7990

IMPROVED FABRICATION AND REPAIR OF ANODES

THE PURCHASE OF NEW OR THE REPAIR OF ANODES IS EXPENSIVE AND TIME CONSUMING. CURRENTLY USED MELTED ON LEAD CLADDING IS INFERIOR TO ELECTRODEPOSITED LEAD BECAUSE OF VARIATIONS OF THICKNESS AND OXIDE INCLUSIONS.

6 80 8004

CO-DEPOSITION OF SOLID LUBRICANTS DURING ANODIZING

LOW FRICTION, HARDCOST SURFACES ARE NEEDED FOR ALUMINUM COMPONENTS.

6 80 8010

PRODUCTION OF ACOUSTIC MICROWAVE FILTERS (CAM)

ACOUSTIC MICROWAVE FILTERS CAN BE PRODUCED UNDER LABORATORY CONDITIONS AT THE RATE OF 1 TO 2 PER MONTH. A PRODUCTION METHOD CAPABLE OF PRODUCING APPROXIMATELY 30 PER DAY IS NEEDED.

6 80 8017

POLLUTION ABATEMENT PROGRAM

MORE STRINGENT ENVIRONMENTAL REQUIREMENTS ARE BEING ESTABLISHED FOR AIR AND WASTE WATER DISCHARGE.

6 80 8024

HIGH SPEED ABRASIVE BELT GRINDING

SLIDE SURFACE DIAMETER AND FINISH IS PRESENTLY PRODUCED ON CYLINDRICAL GRINDING MACHINES USING ABRASIVE WHEELS. THE TIME IT TAKES FOR THIS OPERATION CAN BE SIGNIFICANTLY REDUCED.

PROJECTS ADDED IN 2ND HALF, CY79
(CONTINUED)

- 6 80 8026
APPLICATION OF SYNTHETIC QUENCHANTS TO GUN TUBES

QUENCHANTS ARE NOT SATISFACTORY FROM BOTH THE THERMAL AND SAFETY STANDPOINT.
- 6 80 8030
MANUFACTURING GUIDE FOR ELASTOMERIC SEALS

CONSTANT PROBLEMS IN THE PROCUREMENT OF SATISFACTORY SEALS FOR WEAPONS SYSTEMS, I.E., M140, M127, ETC., ARE EXPERIENCED WITH RESULTAANT SOLE SOURCE PURCHASES.
- 6 80 8034
MANUFACTURING SHOP FLOOR FEEDBACK SYSTEM (CAM)

ROCK ISLAND ARSENAL'S CURRENT METHOD OF COLLECTING SHOP FLOOR DATA IS COSTLY, UNRELIABLE AND DOES NOT PROVIDE ENOUGH DATA FOR PROPER CONTROL OF PRODUCTION.
- 6 80 8035
COATING TUBE SUPPORT SLEEVES WITH BEARING MATERIALS

METALLIZED COATINGS ON SUPPORT SLEEVES FOR GUN MOUNTS ARE BRITTLE AND LACK BOND STRENGTH.
- 6 80 8047
PASS THRU STEADY RESTS FOR TUBE TURNING

ROLLER RESTS PROVIDE NECESSARY SUPPORT FOR GUN TUBE TURNING BUT IT WILL NOT ALLOW TURNING FULL LENGTH IN 1 SET UP. PRESENT METHOD IS TO USE 2 LATHES WITH 2 SET UPS OR LATHE MUST HAVE 2 CARRIAGES.
- 6 80 8054
OPTICAL SCRATCH AND DIG STANDARDS FOR FIRE CONTROL SYSTEMS

PRESENT OPTICAL SCRATCH AND DIG STANDARDS ARE DIFFICULT AND EXPENSIVE TO MANUFACTURE, CALIBRATE, AND MAINTAIN
- 6 80 8057
DUAL RIFLING BROACH REMOVAL SYSTEM

LATE START. INFORMATION COMING.
- 6 80 8059
SALVAGE OF CANNON COMPONENTS BY ELECTRODEPOSITION

COMPONENTS AND GUN TUBES HAVE BEEN REJECTED AND CONDEMNED DUE TO EXCESS STOCK REMOVAL OR MISHMACHINING.

PROJECTS ADDED IN 2ND HALF, CY79
(CONTINUED)

- 6 80 8060
IMPROVED MFG PROCESSES FOR FINAL INSPECTION OF CANNON TUBES
THE CURRENT INSPECTION PROCESS FOR GUN TUBES IS SLOW AND
AWKWARD.
- 6 79 8104
IMPROVED BREACH BLOCK MANUFACTURING
THE WIDE VARIETY OF MACHINE TABLE STANDARDS INVOLVES
EXPENSIVE AND SPACE WASTING ALTERNATIVES TO SPECIFICALLY
DESIGNED MANUFACTURING PROCESSES.
- 6 80 8105
ESTABLISH ROUGH THREAD BLANKS, 8-INCH M201 BUSHING
A SINGLE POINT TOOL IS NOW USED TO PRODUCE THE ROUGH FORMED
BLANK FOR STEP THREADS ON STEP BLOCKS. CURRENT TIME VALUE
IS 13.9 HOURS.
- 6 80 8106
LARGE CALIBER POWDER CHAMBER BORING
POWDER CHAMBERS PRODUCTION ON LARGE BORE CANNON 8" M201
CURRENTLY REQUIRES 14 HRS TO ACCOMPLISH BOTH ROUGH AND
FINISH OPERATIONS.
- 6 80 8107
CREEP FEED CRUSH FORM GRINDING
THE BRACKET SLOT ON THE 105MM M68 BREACH RING IS A HIGH
COST OPERATION. IT IS CURRENTLY MILLED WITH FORM TOOLS IN
TWO OPERATIONS-ROUGH AND FINISH.
- 6 80 8208
MATERIAL HANDLING
A STUDY MADE ON THE 105MM M68 GUN TUBE PRODUCTION LINE
REVEALED 12% OF TIME TO PRODUCE THE TUBE WAS 'CONSUMED IN
MOVING THE TUBE ABOUT' ANOTHER 20% OF THE MFG TIME SPENT IN
MAKING THE TUBE READY AND TAKING THE TUBE DOWN FROM THE
MACHINES.
- 6 80 8341
HOLLOW CYLINDER CUT OFF MACHINE
ESTAB. CYL LENGTH IS DONE 1 OF 2 WAYS. PARTED OFF IN A
LATHE AND FACED TO LENGTH OR SAWED OFF AND THEN SET UP IN A
LATHE FOR FACING TO FINAL LENGTH DIMENSIONS. IN EITHER
CASE, THE OPERATION REQUIRES DOUBLE HANDLING OR SLOW
OPERATING PROCEDURES.

PROJECTS ADDED IN 2ND HALF, CY79
(CONTINUED)

6 80 8342

KEYWAY MILLING MACHINE

155MM M185 REQUIRES 3 KEYWAYS BE MILLED ON C/L TO CLOSE
DIMENSIONS AND TOLERANCES. PRESENTLY MILLED IN 3 DIFFERENT
MACHINES REQUIRING 3 SET UPS AND 3 MOVES.

TOTAL PROJECTS ADDED IN 2ND HALF, CY79 178

MMT PROGRAM
PROJECTS COMPLETED 2nd HALF, CY79



PROJECTS COMPLETED IN 2ND HALF, CY79

DARCOM

4 74 5052

ARMY ENGINEERING DESIGN HANDBOOK FOR PRODUCTION SUPPORT

WORK CONTINUING ON FINAL DRAFT MANUSCRIPT OF
SERVOMECHANISMS.

4 75 5052

ARMY ENG DESIGN HANDBOOKS FOR PRODUCTN SUPPORT.

NO WORK ACCOMPLISHED WITH THIS YEARS FUNDS BUT WORK
CONTINUING ON SEVEN MANUALS.

MERADCOM

E 78 3587

SLUFAE ROCKET MOTOR

THE USEFUL POTLIFE OF THE HTPB PROPELLANT MIX PRIOR TO
CASTING HAS BEEN ACHIEVED. SOME PROGRESS TOWARD REDUCTION
OF CURING TIME HAS ALSO MADE. A COMPLETE TECHNICAL REPORT
HAS BEEN WRITTEN. THE USEFUL POTLIFE WAS DOUBLED TO SIX
HOURS.

E 77 3592

IMPROVED GRAPHITE REINFORCEMENT

LASER AND INDUCTION HEATING FURNACES WERE EVALUATED FOR
THEIR EFFICIENCY IN PRODUCING A REACTION BETWEEN GRAPHITE
FIBERS AND BORON VAPOR. THIS PROJECT PRODUCED A FIBER
SUPERIOR TO THOSE AVAILABLE ON THE MARKET. WORK WILL
CONTINUE WITH PROJECT E793592

E 78 3605

TRANSCALANT-HIGH POWER-TRANSISTOR

RCA COMPLETED THE FY78 PORTION OF THE CONTRACT. FINAL
REPORT WILL FOLLOW COMPLETION OF THE FY79 EFFORT.

CORADCOM

2 76 9679

NUMERICAL CONTROL LATHE LANGUAGE EVALUATION

THIS PROJECT HAS PERFORMED AN UNBIASED STUDY THAT HAS
SUMMARIZED THE CURRENT STATUS OF NC LATHE PROGRAMMING
LANGUAGES AVAILABLE. THE CAPABILITIES OF LANGUAGE
PROCESSORS AVAILABLE TO THE GENERAL PUBLIC EXCEED THOSE
CURRENTLY IN USE BY DOD COMPONENTS.

PROJECTS COMPLETED IN 2ND HALF, CY79
(CONTINUED)

2 76 9758

PROCESSES FOR METAL NITRIDE OXIDE SEMICONDUCTORS FOR BORAM

WESTINGHOUSE BALTIMORE BUILT LARGE SCALE MNOS ICs FOR MEMORY MODULES. THEY ARE USED IN AVRADCOM ACCIDENT DATA SYSTEM + F-16 RADAR. EACH HYBRID MODULE CONTAINS 16 MEMORY CHIPS. THEY ARE BEING EVALUATED FOR NAVY "HARPOON" RADAR, P-3 AIRCRAFT, + A COMPUTE

F 79 9891

ARCTIC (-55 C) ELECTRICAL CABLE JACKET

THIS PROGRAM HAS BEEN CANCELLED. NO BIDDERS RESPONDED TO THE RFO.

ERADCOM

2 75 9525

HOT PRESSING OF PIEZO CERAMIC ELEMENTS FOR HV TRANSFORMERS

HONEYWELL APPLIED HOT PRESSING, SEMI AUTOMATIC SILK SCREENING, + SEMI AUTOMATIC DISK POLARIZATION TO MAKE LEAD ZIRCONATE-LEAD TITANATE CERAMIC ELEMENTS FOR PIEZO CERAMIC TRANSFORMERS. ARE NOT COST EFFECTIVE VS FERROMAGNETIC CORE TRANSFORMERS.

2 76 9631

IC FABRICATION USING ELECTRON BEAM TECHNOLOGY

TI COMPLETED WORK ON THE 256 BIT BIPOLAR RANDOM ACCESS MEMORY USING ELECTRON BEAM EXPOSURE OF TI RESIST ON THE WAFER, AND SELECTIVE PLASMA ETCHING. TI DEMONSTRATED 4U DESIGN RULES FOR NEXT GENERATION VLSI DEVICES. YIELD IMPROVEMENTS WEREN'T CONCLUSIVE

2 76 9754

CONTIN CYCLE PROC OF SHOCK RESISTANT QUARTZ CRYSTAL UNITS

GEND DEVELOPED A SEMIAUTOMATIC IN-LINE ULTRAHIGH VACUUM FABRICATION CHAMBER FOR ULTRA-VIOLET CLEANING, BAKING, PLATING + SEALING HIGH SHOCK RESISTANT QUARTZ CRYSTALS. PHASE I OPER TESTS MET ALL SPECS. WORK IS CONTINUING UNDER 2 77 9754 + H 79 9807.

2 76 9774

IMP PLATED-THRU HLS BY ALTERING DRILL GEOMETRY + FINISH

VARIOUS TECHNIQUES OF DETECTING DRILL WEAR WERE EVALUATED. DRILL FINISHES AND POINT GEOMETRIES WERE EVALUATED USING IR SENSORS. THE CONTRACTORS FINAL REPORT HAS BEEN DISTRIBUTED.

PROJECTS COMPLETED IN 2ND HALF, CY79
(CONTINUED)

M 79 9963

LOW COST E-BEAM EQUIPMENT

THE ADVISORY GROUP ON ELECTRON DEVICES ADVISED AGAINST PERFORMING THIS PROJECT. BIDS FROM THREE LEADING ELECTRON BEAM EQUIPMENT MANUFACTURERS WERE RETURNED UNOPENED. MANY KNOWLEDGABLE PERSONS FEEL THIS IS A LOSS TO INDUSTRY NOT TO HAVE THIS EQUIPMENT.

AMMRC

M 77 6350

MATERIALS TESTING TECHNOLOGY (MTT)

THIS PROJECT HAS BEEN COMPLETED.

M 75 6350

MATERIALS TESTING TECHNOLOGY (MTT)

THIS PROJECT HAS BEEN COMPLETED.

M 76 6350

MATERIALS TESTING TECHNOLOGY (MTT)

THIS PROJECT HAS BEEN COMPLETED.

M 76 6350 1807

NOT EQPT FOR RESIDUAL STRESS MEASUREMENTS

THE BREADBOARD CONFIGURATION FOR THE "DETECTOR ASSEMBLY", X-RAY HEAD ASSEMBLY FOR BOTH THE CU AND CR TUBES AND "THE HIGH VOLTAGE POWER SUPPLY ASSEMBLY" HAVE BEEN PRODUCED AND OPERATED. THE SOFTWARE IS ESSENTIALLY COMPLETE.

M 78 6390

PROGRAM IMPLEMENTATION AND INFORMATION TRANSFER

PREPARED DARCOM WIDE TECH NOTES FOR DISSEMINATION.

NARADCOM

A 74 200N

MFG OF TURNING SHOE LASTS USING NUMERICAL CONTROL.

THE CONTRACT WAS TERMINATED DUE TO THE FAILURE OF THE CONTRACTOR TO MEET STATED REQUIREMENTS. ANOTHER ATTEMPT TO SOLVE THE BASIC PROBLEM SHOULD BE SUCCESSFUL.

PROJECTS COMPLETED IN 2ND HALF, CY79
(CONTINUED)

MICOM

R 77 3091

APPLICATION OF CAN TO AFFIXING ELEC CONNECTORS TO CABLES

MARTIN MARIETTA DEMONSTRATED ITS COMPUTER CONTROLLED WIRE ROUTING MACHINE. IT CAN INSERT A PIN TERMINATED WIRE IN A CONNECTOR AND THEN ROUTE THE WIRE OVER A HARNESS LAYOUT BOARD, FLEX ITS WIRE, AND INSERT THE OTHER PIN IN ANOTHER CONNECTOR.

R 78 3116

ROSETTE AIR OFFENSE SEEKER OPTICS AND DETECTORS

GENERAL DYNAMICS COMPLETED PRODUCTION ENGINEERING THE STRINGER SEEKER OPTICS AND DETECTOR. THIS INCLUDES UV/IR SANDWICH DETECTOR, OPTICS, IR FILTER, CRYOGENIC INTERFACE, + PREAMPLIFIER. OPTICAL ALIGNMENT AND SECURING STRUCTURE WERE ALSO ENGINEERED.

R 78 3136

IMP. MANUFACTURING PROCESSES FOR COMPLIANT BEARING CYRDS

NONE REPORTED EXCEPT THAT THIS TASK IS NOW COMPLETED.

R 78 3140

IMP MANUFACTURING PROCESSES FOR SILICON VIDICONS

MARTIN MARIETTA EVALUATED THE NEW CERAMIC TV CAMERAS PRODUCED BY RCA ON PROJ 3763170. ADVANCEMENTS MADE BY RCA IN SILICON DIODE ARRAY VIDICON TARGETS WERE NOTEWORTHY. ALSO, COST WAS CUT FROM \$5000 IN 1975 TO \$620 IN 1980 IN QUANTITY OF 2500.

R 77 3160

CLEANLINESS + PROCESS CRITERIA FOR CIRCUIT BOARDS

LACK OF FUNDS HALTED WORK. MICOM IS IN THE PROCESS OF EXTENDING THE CONTRACT SO THAT MARTIN MARIETTA CAN CONTINUE TO DEVELOP A METHOD TO IDENTIFY, QUANTIFY AND REMOVE CONTAMINANTS FROM PCBs. MARTIN BOUGHT A LIQUID CHROMATOGRAPH WITH COMPANY FUNDS.

R 78 3204

INTERNAL SHEAR FORGING PROCESSES FOR MISSILE PRIME STRUCT

HOT ROLLING EXPERIMENTS WERE CONDUCTED ON ALUMINUM ALLOY 2014-0 TO ASCERTAIN ITS RESPONSE TO MECHANICAL PROCESSING AND SUBSEQUENT HEAT TREATMENT. TOOLING AND EQUIPMENT FABRICATION WAS COMPLETED.

PROJECTS COMPLETED IN 2ND HALF, CY79
(CONTINUED)

R 78 322A

PRODUCTION METHODS FOR EXTRUDABLE HTPB PROPELLANT

THE PROCESS SELECTED AS A RESULT OF THE EFFORT CONSISTS OF AUTOMATING CONVENTIONAL PROCESSING STEPS, WHICH TAKES ADVANTAGE OF QUICK CURE TECHNOLOGY. PRODUCTION EQUIPMENT IS CURRENTLY BEING BUILT AS A RESULT OF THIS COMPLETED PROJECT.

R 78 3268

AUTOMATIC CONTROL OF PLATING (CAM)

PHASE I HAS BEEN COMPLETED.

R 78 3372

MANUFACTURING METHODS FOR MAGNETIC MATERIALS

NO WORK STATED OTHER THAN THAT THIS IS A FINAL REPORT.

TARADCOM

T 78 4575

LASER WELDING TECHNIQUES FOR MILITARY VEHICLES(PHASE I)

THIS COMPLETED EFFORT DEMONSTRATED THAT LASER WELDING OF ARMOR IS FEASIBLE AND APPEARS TO BE COST EFFECTIVE.

T 78 5062

PRODUCTION OF ARMORED VEHICLE VISION BLOCKS

BALLISTIC TESTS ON SETS OF TRANSPARENCIES SELECTED BY AMMRC ESTABLISHED MATERIAL COMBINATIONS FOR BEST BALLISTIC PROTECTION VERSUS COST. MATERIALS INCLUDE HARD GLASS, SAPHIRE, POLYCARBONATE AND ANNEALED GLASS, WILL BE USED IN VISION BLOCKS.

T 79 5081

FABRICATION OF FRICTION RINGS AND REACTION PLATES- PHASE 2

NO BIDS WERE RECEIVED ON THE RFP. THE PROGRAM WAS CANCELLED, FUNDS WILL BE REPROGRAMMED INTO HIGHER PRIORITY PROJECTS.

T 77 5085

PRODUCTION TECHNIQUES FOR FABRICATION OF TURBINE RECUPERATOR

THE LASER WAS DELIVERED AND WORK ON PHASE I WAS COMPLETED.

PROJECTS COMPLETED IN 2ND HALF, CY79
(CONTINUED)

AVRADCOM

1 76 7164

FILAMENT WINDING PRECISION RESIN IMPREGNATION SYSTEM

PROJECT WORK IS COMPLETED. AET FILAMENT WINDING MACHINE WAS DEVELOPED THAT MET THE PROGRAM OBJECTIVE OF PRODUCING RUVING WITH APPROX 2% RESIN CONTENT BY WEIGHT. NO COST ADVANTAGES WERE GAINED. COMMERCIAL MACHINE IS AVAILABLE WITH PROJECT IMPROVEMENTS.

ARRADCOM-ARRCOM (AMMO)

5 77 1337

ENGR STUDY F/ADAPT TRF OF UK TECH-LCHR SYS W/RP/BUTYL GREN

PROCESS BASELINE PREPARED, COORDINATED AND FINALIZED FOR PRODUCTION OF SMOKE PELLET FOR LBA1 RP GRENADE. TECHNICAL REPORT ASCSL-TR-79063 PUBLISHED IN OCT 79 ON WORK EFFORT.

5 74 4000

AUTOMATED MSS DETONATOR PRODUCTION EQUIPMENT

FINAL STATUS REPORT WAS SUBMITTED.

5 75 4009

AUTO OF EQUIP FOR A/P OF SMALL SHAPED CHARGE ROCKETS

FINAL STATUS REPORT WAS SUBMITTED.

5 78 4139

APPLICATION OF RADAR TO BALLISTIC ACCEPTANCE TEST OF AMMO

THIS IS A FINAL REPORT. NO SPECIFIC EFFORTS CAN BE IDENTIFIED FROM THE STATUS REPORT BUT THIS FY OF EFFORT WAS USED PRIMARILY TO CORRECT DEFICIENCIES AND TO TEST THE SYSTEM. TESTING IS CONTINUING WITH FY79 FUNDS.

5 76 4280

M577 FUZE AUTOMATIC PROCESS CONTROL PROTOTYPE EQUIPMENT

THIS PROJECT IS COMPLETE. SEE PROJECT 5 77 4280 FOR IMPLEMENTATION INFORMATION.

PROJECTS COMPLETED IN 2ND HALF, CY79
(CONTINUED)

5 77 4280

M577 FUZE AUTOMATIC PROCESS CONTROL PROTOTYPE EQUIPMENT

THIS PROJECT IS COMPLETE. AUTOMATIC REGULATION EQUIP AND AUTOMATIC POISING EQUIP FOR THE M577 FUZE WAS SUCCESSFULLY DESIGNED AND FABRICATED. ADDITIONAL MACHINES ARE BEING BOUGHT FOR PDN. THE TDP IS BEING CHANGED TO REQUIRE MANDATORY USE OF EQUIP.

5 76 4281

ENERGY SAVING AT ARMY AMMO PLANTS

SEE THE FOLLOWING INDIVIDUAL TASKS FOR WORK STATUS.

5 76 4281 A01

PROCESS ENERGY INVENTORY

THE FIRST YR OF A TWO YR PROCESS ENERGY AUDIT OF RAAP, S MFG OPNS HAS BEEN COMPLETED. EFFORTS INCLUDED THE ESTAB OF AUDIT METH, PROCUREMENT AND INSTALLATION OF ENERGY MEASURING INSTRU, AND ACQUISITION OF DATA FROM KEY PROCESSING AREAS.

5 76 4281 A04

WASTE HEAT FROM CHEMICAL REACTIONS

AN ANAL WAS COMPLETED OF THE ENERGY-INTENSIVE PROCESS OPNS AT RAAP, HAAP, AND VAAP FOR THE PURPOSE OF IDENTIFYING THOSE PROCESSES WHICH COULD BE MADE TO FUNCTION EFFECTIVELY WITH SUBSTANTIALLY LESS ENERGY.

5 76 4281 B01

PROCESS ENERGY INVENTORY FOR METAL PARTS

A SURVEY OF ENERGY USE AT SCRANTON AAP WAS CONDUCTED AND A FINAL REPORT WAS PUBLISHED. ENERGY USE PATTERNS WERE DETERMINED, OBVIOUS ENERGY WASTING PROCESSES WERE IDENTIFIED, AND A DATA BASE WAS DEVELOPED FOR IMPLEMENTING ENERGY CONSERVATION MEASURES.

5 76 4281 B02

REDUCED FORGING TEMPERATURE

PILOT QUANTITIES OF 155MM PROJ WERE FORGED AT PROGRESSIVELY REDUCED TEMP TO ESTAB THE LOWER LIMITS OF FORGING TEMPS WHICH WOULD STILL PRODUCE ACCEPTABLE FORGINGS. IT WAS FOUND THAT FORGING TEMPERATURES COULD BE REDUCED TO 2000 F.

PROJECTS COMPLETED IN 2ND HALF, CY79
(CONTINUED)

5 77 4285

TNT EQUIVALENCY TESTING FOR SAFETY ENGINEERING.

CONDUCTED TESTS ON M26E1 PROP AND PUBLISHED REPORT
ARLCD-CR-79-10 ON EFFORT. CONDUCTED TESTS ON BALL POWDER
WC-844 AND M6 PROP. PUBLISHED REPORT ARLCD-TR-79026 ON TNT
EQUIVALENCY OF R284 TRACER COMP AND 1559 AND 1560 IGNITER
MIX.

5 77 4289

HAZARD CLASSIFICATION OF PROPELLANTS AND EXPLOSIVES

FRICTION, IMPACT, ELECTROSTATIC CHARGE AND HEATING
IDENTIFIED MOST PROBABLE CAUSES OF AN ACCIDENT. SENSITIVITY
CRITERIA DERIVED FOR FRICTION, IMPACT AND ELECTROSTATIC
CHARGE STIMULI. HAZARDS CLASSIFICATION PROCEDURE WAS
DEVELOPED

5 77 4302

ACCEPTANCE CRITERIA FOR CONTINUOUS SINGLE BASE PROPELLANT

THE FINAL REPORT AND SPECS HAVE BEEN RECEIVED FROM RADFORD
AAP.

5 76 4302

ACCEPTANCE CRITERIA FOR CONTINUOUS SINGLE BASE PROPELLANT

THE FINAL REPORT AND INPUT TO TDP WERE COMPLETED.

5 76 4303

ACCEPTANCE OF CONTINUOUSLY PRODUCED BLACK POWDER

PCRL COMPLETED ITS WORK ON THE TEST DEVICE.

5 77 4303

ACCEPTANCE OF CONTINUOUSLY PRODUCED BLACK POWDER

BALLISTIC RESEARCH LAB FABRICATED STATIC TEST DEVICE TO
EVALUATE BLACK POWDER.

5 77 4304

SPIN TEST FOR ACCEPTANCE OF ROCKET GRAINS-STARG

PROJECT WAS TERMINATED. THE CONTRACTOR PROPOSAL EXCEEDED
THE PROJECT FUNDING LEVEL BY APPROXIMATELY \$180K. AS A
RESULT OF THIS SHORT FALL THE PROJECT WAS TERMINATED. \$100K
IS BEING RETURNED TO PBM FOR REPROGRAMMING.

PROJECTS COMPLETED IN 2ND HALF, CY79
(CONTINUED)

- 5 76 4311
AUTO PROD EQUIP FOR LAP OF XM 692 MINE DISPENSING SYSTEM
FINAL STATUS REPORT SUBMITTED FOR FY76 EFFORT. EFFORT CONTINUING WITH FY77 FUNDS.
- 5 77 4410
MFG TUNGSTEN PENETRATORS TO SHAPE BY TAPER SWAGING
PROJECT IS COMPLETE. RESULTS WILL NOT BE IMPLEMENTED BECAUSE THE ITEM WILL GO OUT OF PRODUCTION IN MAY 80.
- 5 77 4431
AUTOMATED EQUIPMENT FOR MORTAR IGNITION CARTRIDGES
FMC CONTRACT TERMINATED IN FEB 79. CONTRACTOR IS IN PROCESS OF FINALIZING COST AND PROVIDING REPORT.
- 5 78 4431
AUTOMATED EQUIPMENT FOR MORTAR IGNITION CARTRIDGES
FMC CONTRACT TERMINATED IN FEB 79. CONTRACTOR IS IN PROCESS OF FINALIZING COST AND PROVIDING REPORTS.
- 5 77 4457
MULTI-TOOLED IOWA DETONATOR LOADING MACHINE
FINAL STATUS REPORT WAS SUBMITTED. THIS PROJECT INSTALLED A PROTOTYPE MULTI-TOOLED DETONATOR LOADER AT IOWA AAP WHERE IT IS CURRENTLY PRODUCING DETONATORS. FINAL ADJUSTMENTS TO IMPROVE QUALITY ARE UNDERWAY AS PART OF MMT PROJECT 4000.
- 5 75 6211
SINTERED STEEL PREFORMS FOR WORKING INTO FRAG SHELL BODIES
PROJECT IS COMPLETE. NO IMMEDIATE PLANS FOR IMPLEMENTATION.
- 5 75 6558
CAM-ADAPTATION OF AUTOMATIC DYNAMIC/STATIC FUZE REGULATION
EQUIPMENT PROVE OUT WAS NOT SUCCESSFUL. ADDITIONAL TESTING IS REQUIRED. CURRENT PDN IS ALMOST COMPLETE. THE EQUIPMENT WILL BE LAID AWAY AS IS AND THE CONTRACT TO FINISH THE MT WORK WILL BE CANCELLED.
- 5 74 6571
ENGR SUPPORT OF MORTAR AMMO MPTS MODERNIZATION
PROJECT COMPLETED. HOT CUP-COLD COIN MANUFACTURE HAS BEEN ESTABLISHED FOR 81MM AND 60MM PROJECTILES. LETHALITY TESTING METHODOLOGY AND BASELINE HAVE BEEN ESTABLISHED FOR 81MM. 60MM LETHALITY TESTS INDICATE THAT TOP CAN BE CHANGED TO LOWER MPTS COST.

PROJECTS COMPLETED IN 2ND HALF, CY79
(CONTINUED)

5 76 6596

BALL PROPELLANT PILOT PLANT STUDIES

WORK ON THIS PROJ INCLUDED FACILITY RENOVATION, BATCH STILL COMPLEX, MATLS, LACQUER RHEUMETER, SALT AND COLLOID, EQUIPMT EVAL, CONTINUOUS NET LINE DESIGN, AND CYCLE TIME STUDIES. 1977 AND 1978 FOLLOW-ON PROJECTS CONTINUE MOST OF THESE STUDIES.

5 76 6632

AUTO INSPECTION DEVICES FOR ART PROJECTILES IN MOD PLANTS

PROJECT HAS BEEN CONSIDERED COMPLETE. PBM HAS WITHDRAWN FUNDS FOR THE COMPLETION OF THIS TASK. THE RATIONALE FOR THIS CLOSE OUT IS THAT THE NECESSARY REWORK REQ. MAY NOT PROVIDE A WORKABLE SYSTEM

5 76 6640

PROD CONTROL/QA OF SHAPED CHG LINERS BY AUTO X-RAY ANAL

PROJECT WAS COMPLETED. THE QUANTITIES MEASURED FROM THE FLASH RADIOGRAPH WERE JET TIP VELOCITY, BREAK-UP TIME AND JET PARTICLE LENGTHS AND TOTAL JET LENGTH. THE TECH REPORT IS TO BE COMPLETED THIS QUARTER.

5 77 6716

MATH MODEL OF FORMING OPERATIONS FOR ARTILLERY DESIGN

FINAL RCS-301 REPORT RECEIVED.

5 76 6759

FEAS F/AUTO TRANSFER-HOT FORMING PRESSES F/MORTAR AMMO

A TOTAL OF 500 81MM FORGINGS MANUFACTURED FROM AISI 1340 STL WERE PRODUCED ON A HOT FORMER OWNED BY NATIONAL MACHINERY. THE PROJECT ESTABLISHED THE CAPABILITY TO PRODUCE HIGH QUALITY 81MM FORGINGS. THIS PROJECT HAS BEEN COMPLETED.

ARRADCOM-ARRCOM (WPNS)

6 77 7213

HIGH SPEED CHROME PLATING TECHNIQUE

A FULL LENGTH ROTATING NON-CONFORMING ANODE INCORPORATED WITH A PUMP THROUGH ELECTROLYTE WAS DETERMINED TO BE THE MOST SUITABLE APPROACH FOR ACHIEVING A HIGH SPEED PLATING TECHNIQUE. THIS APPROACH WILL FORM THE BASIS FOR AN FY79 PROJECT FOR PROTOTYPE.

PROJECTS COMPLETED IN 2ND HALF, CY79
(CONTINUED)

- 6 76 7241
IMPROVEMENT- HONING EQUIPMENT AND PROCEDURES,

IMPROVEMENTS TO HONING MACHINE AND SUPPORTING HAVE BEEN COMPLETED AND A FINAL REPORT HAS BEEN PREPARED.
- 6 77 7707
AUTOMATED PROCESS CONTROL FOR MACHINING (CAM)

THIS IS A FINAL REPORT, THE SYSTEM DEVELOPED IS COMPLETE AS A SEPERATE ENTITY FOR USE IN THE AUTOMATED PLANNING AND CONTROL OF TURNING OPERATIONS AT ROCK ISLAND ARSENAL. IMPLEMENTATION WILL CONTINUE IN THE NC PROGRAMMING AND METHODS/STANDARDS AREAS.
- 6 77 7722
IMPLEMENTATION OF THE 8 INCH XN201 ON ROTARY FORGE LINE

PROJECT IS COMPLETE, DUE TO HIGH PRODUCTION RATES ALREADY PLANNED FOR THE GFM ROTARY FORGE, THIS PROJECT WILL NOT BE IMMEDIATELY IMPLEMENTED.
- 6 77 7727
RECYCLING OF SCRAP GUN TUBES BY ROTARY FORGING

PROJECT IS COMPLETE, WORK IS CONTINUING UNDER PROJECT 6 78 7727.
- 6 77 7733
ELIMINATION OF EXTERIOR TUBE MACHINING PRIOR TO SKAGE AUTO.

PROJECT IS COMPLETE AND HAS BEEN IMPLEMENTED ON THE 8 INCH X201.
- 6 78 8017
POLLUTION ADJATEMENT PROGRAM

THIS PROJECT HAS BEEN COMPLETED. STUDIES OF NON-CYANIDE CADMIUM AND COPPER PLATING BATHS HAVE BEEN COMPLETED AND BATHS TO REPLACE CYANIDE PLATING SOLUTIONS WERE SELECTED. NON-CYANIDE DERUSTING BATHS ARE NOW USED FOR PRECLEANING OF VARIOUS WPN PARTS.

TOTAL PROJECTS COMPLETED IN 2ND HALF, CY79 71

MMT PROGRAM
SUMMARY PROJECT STATUS REPORT



PRECEDING PAGE BLANK-NOT FILLED

MANUFACTURING METHODS AND TECHNOLOGY PROGRAM

SUMMARY PROJECT STATUS REPORT

The Summary Project Status Report for each Major Subordinate Command (MSC) is preceded by the tabulated MSC MMT project funding status. The accuracy of funding amounts is based on the individual semiannual status reports. The status as reported here is the IBEA condensation of information contained in the report or other comments as deemed useful. If a status report was not provided, a pertinent comment was made so that the project would be printed.

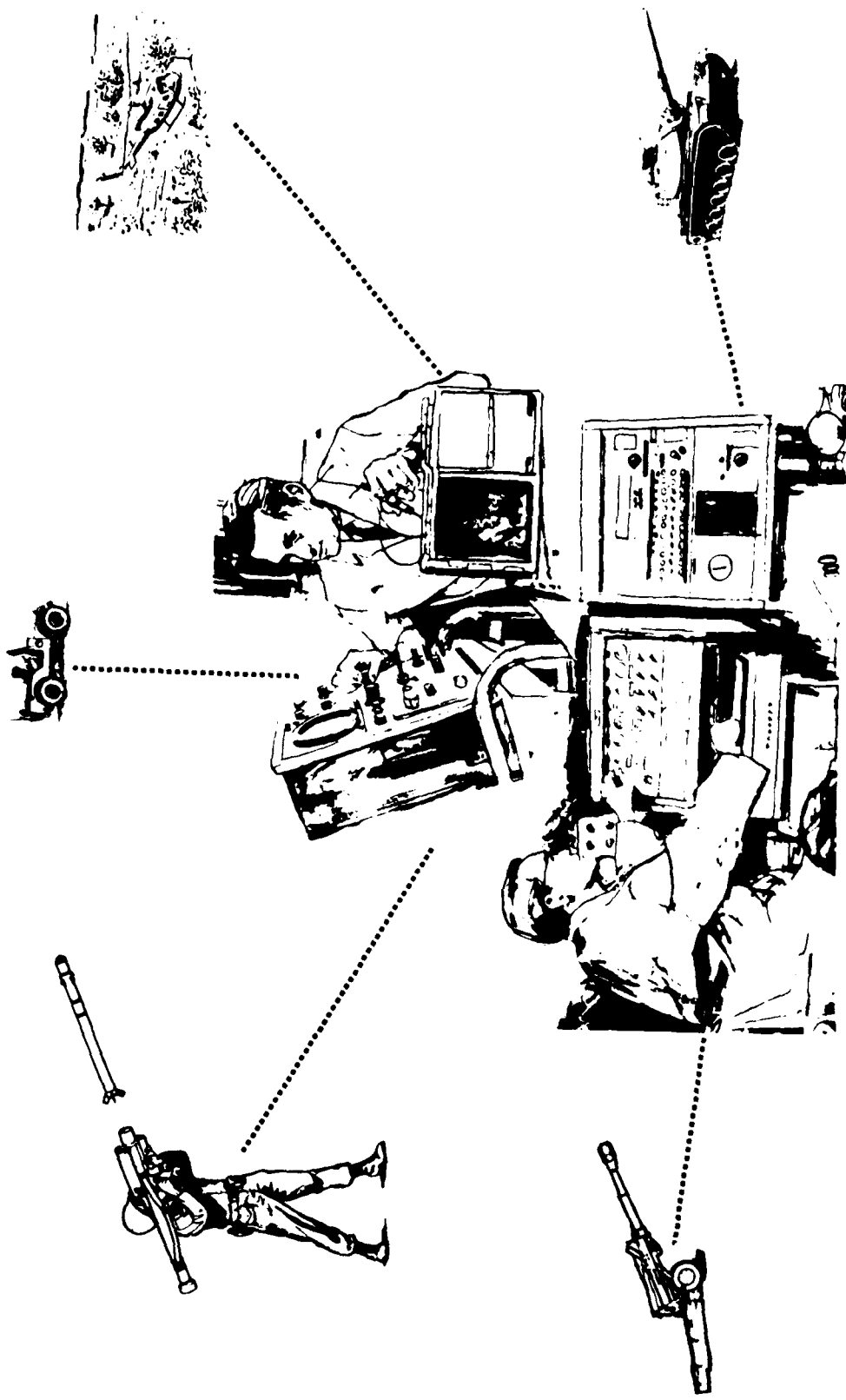

**TEST AND EVALUATION COMMAND
(TECOM)**

TEST AND EVALUATION COMMAND
CURRENT FUNDING STATUS, 2ND CY79

FISCAL YEAR	NO. OF PROJECTS	AUTHORIZED FUNDS (\$)	* CONTRACT FUNDS ALLOCATED (\$)	* CONTRACT FUNDS EXPENDED (\$)	* INHOUSE REMAINING (\$)	* INHOUSE FUNDS EXPENDED (\$)
77	1	829,400	4,000	0 (0%)	824,600	756,700 (91%)
78	1	735,000	159,500	129,900 (81%)	575,500	563,200 (97%)
79	1	881,000	57,000	57,000 (100%)	824,000	329,700 (40%)
80	1	822,000	0	0 (0%)	822,000	0 (0%)
81	0	0	0	0 (0%)	0	0 (0%)
82	0	0	0	0 (0%)	0	0 (0%)
TOTAL	4	3,267,400	221,300	186,900 (84%)	3,046,100	1,649,600 (54%)

AUTHORIZED FUNDING CONTRACT ALLOCATED 7% INHOUSE REMAINING 93%

S U M M A R Y P R O J E C T S T A T U S R E P O R T
 2ND SEMI ANNUAL SUBMISSION CY 79 RCS DRGMT-301

MANUFACTURING METHODS AND TECHNOLOGY PROGRAM

PROJ NO.	TITLE + STATUS	AUTHORIZED (8000)	CONTRACT VALUES (8000)	EXPENDED LABOR AND MATERIAL (8000)	ORIGINAL PROJECTED COMPLETE DATE	PRESENT PROJECTED COMPLETE DATE
0 77 5071	IMPROVEMENT OF PRODUCTION TEST METHODOLOGY FOR PROJECT STATUS SEE SUBTASKS BELOW.	829.4	4.8	756.7	DEC 78	JUN 80
0 77 5071 03	BACKSPALLING CHARACTERISTICS TEST FIRINGS WERE COMPLETED ON 2 TYPES OF DUAL HARDNESS STEEL ARMOR PLATE. ALSO, BALLISTIC TESTS WERE CONDUCTED AND IMPACT DAMAGE WAS RECORDED AND PHOTOGRAPHED. THE TASK HAS BEEN EXPANDED TO INCLUDE OTHER COMBINATIONS OF PLATE.					JUN 80
0 77 5071 07	SMALL CALIBER WEAPON COOK-OFF TESTING A SUITABLE FACILITY HAS BECOME AVAILABLE FOR CONDUCTING FIRING TRIALS. THE PROJECT HAS BEEN REFUNDED + WILL BE COMPLETED IN FY80.					JUN 80
0 77 5071 09	RISK IN ACCEPTING MATERIAL NOT CONFORMING TO EMI REQUIREMENT THE RISK ASSESSMENT TECHNIQUE USE AT THE EPG SATISFIES AFG REQ, DATA AND SOFTWARE REQUIREMENTS HAVE BEEN ESTABLISHED FOR THE MAGNETIC TAPE DATA INTERCHANGE WITH EPG, THE FINAL REPORT WILL BE PUBLISHED IN FEB 1980.					JUN 80
0 77 5071 11	COOLING CAPACITY OF AIR CONDITIONS PREVIOUSLY UNEXPLAINED VARIATIONS IN THE COEFFICIENT OF DISCHARGE (CD) VALUES WERE FOUND TO BE DUE TO MINUTE AIR LEAKAGE BETWEEN THE LAMINAR FLOW ELEMENTS AND THE NOZZLES, THE LEAKS WERE SEALED AND THE (CD) VALUES NOW CONFORM TO ASHRAE STANDARDS.					JUN 80
0 77 5071 14	SMOKE-OBSCURANTS THE FINAL REPORT OF THE SMOKE TRANSPORT MODEL BY HEADQUARTERS, THE RESULTS OF THIS TASK WERE BRIEFED TO JTCCG/ME SMOKE AEROSOL WORKING GROUP, THE RESPONSE TO THE RESULTS OF THIS STUDY WAS FAVORABLE.				DEC 78	JUN 80
0 77 5071 17	SALT FOG TEST PROCEDURES SUBTASK WAS COMPLETED, THE FINAL REPORT HAS BEEN PUBLISHED.				DEC 78	JUN 80
0 77 5071 18	GUN ATR DEFENSE SYSTEM TEST AND EVALUATION A REVIEW OF RECENT TESTS OF AIR DEFENSE SYSTEMS HAS BEEN COMPLETED, COMPUTER PROGRAMS TO BE USED IN THE DATA ANALYSIS EFFORTS HAVE BEEN DEVELOPED, DATA ANALYSIS AND THE FINAL REPORT IS UNDER WAY.				DEC 78	JUN 80
0 77 5071 22	PRODUCTION TEST RANGE FIRST PHASE OF THE INDUSTRIAL ENGINEERING CONTRACT HAS BEEN COMPLETED.				DEC 78	JUN 80

MANUFACTURING METHODS AND TECHNOLOGY PROGRAM
SUMMARY PROJECT STATUS REPORT
2ND SEMI ANNUAL SUBMISSION CY 79 RCS ORCMT-301

PROJ NO.	TITLE + STATUS	AUTHORIZED (\$000)	CONTRACT VALUES (\$000)	EXPENDED LABOR AND MATERIAL (\$000)	ORIGINAL PROJECTED COMPLETE DATE	PRESENT PROJECTED COMPLETE DATE
0 77 5071 28	IMPACT SENSITIVITY OF FUZES THE LITERATURE SEARCH HAS BEEN COMPLETED. PROPOSALS FOR FIELD EVALUATION OF SEVERAL METHODS FOR SIMULATING THE EFFECTS OF RAIN AND BRUSH DURING PRODUCTION TESTING OF PROJECTILES ARE BEING CONSIDERED.					JUN 80
0 77 5071 29	AUTOMATIC DATA COLLECTION SYSTEMS FOR AIR CONDITIONERS NEW ELECTRONIC ANALOG INSTRUMENTATION HAS BEEN ACQUIRED. DISCREPANCIES BETWEEN THE NEW AND OLD INSTRUMENTATION EXISTS. THE NEW INSTRUMENTATION HAS EXCELLENT REPEATABILITY. THE ELECTRONIC ANALOG INSTRUMENTATION HAS BEEN RECALIBRATED.					JUN 80
0 77 5071 30	RADIATION DOSIMETRY FEASIBILITY OF THE NEUTRON ACTIVATION TECHNIQUE FOR SPECTRUM CHARACTERIZATION AT DISTANCES UP TO 170M HAS BEEN DEMONSTRATED. ALSO, A TECHNIQUE HAS BEEN DEVELOPED USING TISSUE EQUIVALENT IONIZATION CHAMBERS FOR MEASURING TOTAL NEUTRON AND GAMMA DOSE.					JUN 80
0 78 5071	IMPROVEMENT OF PRODUCTION TEST METHODOLOGY SEE SUBTASKS BELOW FOR PROJECT STATUS.	735.0	159.5	563.2	DEC 79	MAY 80
0 78 5071 10	TEST OPERATIONS PROCEDURES DURING THE REPORTING PERIOD COVERED BY THIS REPORT, TEN TEST OPERATING PROCEDURES WERE PUBLISHED.					MAY 80
0 78 5071 31	GEUAC AND CONVENTIONAL INSTRUMENTATION DATA CORRELATION THE TECHNICAL DEFINITION REQUIREMENT FOR TESTING GENERATOR PER MIL-STD-705 WERE ESTABLISHED. COMPUTER PROGRAMS HAVE WRITTEN TO COMPUTE THE HARMONIC CONTENT AND WAVEFORM DEVIATION OF THE TEST GENERATOR WAVEFORM.					MAY 80
0 78 5071 32	ELECTROSTATIC GENERATION AND PRECIPITATION DATA FROM THE FARADAY CAGE EXPERIMENTS INDICATED THAT THIS IS AN ACCEPTABLE METHOD FOR MEASURING ELECTROSTATIC CHARGE. THE CONSTRUCTION OF A MAN-SIZED FARADAY CAGE HAS BEEN DELAYED DUE TO LACK OF FUNDS.					MAY 80
0 78 5071 34	GUN AIR DEFENSE SYSTEM LASER TECHNIQUES TASK WAS SUSPENDED DUE TO SHORTAGE OF TECHNICAL MANPOWER. THE PRELIMINARY STUDY INDICATED THAT A SIGNIFICANT IMPROVEMENT CAN BE REALIZED WITH A NEW TRACKING SYS. FUTURE WORK WILL BE COORDINATED WITH THE ALL-WEATHER FIRE CONTROL SYS INST. EVALUATION.					MAY 80
0 78 5071 35	PROJECTILE EDDY CURRENT INSPECTION AN EDDY CURRENT INSPECTION INSTRUMENT AND SCANNER HAS BEEN EVALUATED AND ITS CRACK DETECTION CAPABILITY HAS BEEN ESTABLISHED. TESTS HAVE SHOWN THAT A HANDLING SYS IS REQ. TO ACCOMPLISH THE LOW COST PER PROJECTILE INSPECTION.					MAY 80

MANUFACTURING METHODS AND TECHNOLOGY PROGRAM
 S U M M A R Y P R O J E C T S T A T U S R E P O R T
 2ND SEMI-ANNUAL SUBMISSION CY 79 RCS DRGMT-301

PROJ NO.	TITLE + STATUS	AUTHOR- RIZED	CONTRACT VALUES	EXPENDED LABOR AND MATERIAL (\$000)	ORIGINAL PROJECTED COMPLETE DATE	PRESENT PROJECTED COMPLETE DATE
0 78 5071 36	IN-9URE RADIOGRAPHY TECHNIQUE APPLICATION AN ALIGNMENT LASER DEVICE AND A DETECTOR BASE TUBE HAVE BEEN ADDED TO FACILITATE ALIGNMENT AND ELECTRONIC SENSING. A FEASIBILITY STUDY OF INTERNAL IMAGING STRUCTURE OF 8" BINARY ROUND WAS CONDUCTED. THE FINAL REPORT IS SCH. FOR COMPLETION JUNE 1980.					MAY 80
0 78 5071 37	MILITARY VEHICLE ROLL OVER TESTS A CONTRACT TO ANALYZE THE OPERATIONS THAT CONTRIBUTE TO THE PROPENSITY OF MILITARY VEHICLES TO ROLL DURING TEST MANEUVERS WAS COMPLETED ACCOMPANIED BY A FINAL REPORT. PRACTICAL FIELD TEST WILL BE EVALUATED FOR ROLLOVER PROPENSITY.					MAY 80
0 78 5071 39	TRANSDUCER VELOCITY MEASUREMENT A CONTRACT SCOPE OF WORK HAS BEEN FORWARDED TO PROCUREMENT. THIS CONTRACT IS A FEASIBILITY STUDY OF ACOUSTICAL TRANSDUCER SYSTEM DESIGN AND DEVELOPMENT FOR USE IN VELOCITY MEASUREMENTS.					MAY 80
0 78 5071 40	DIRECT FIRE WEAPON ADVANCED MUZZLE BORE SIGHT AN IMPROVED OPTICAL BORESIGHT IS UNDER DEVELOPMENT. THIS INST. WILL INCORPORATE THE DESIRED FEATURES OF THE PRESENT APG SIGHT WITH INCREASED ACCURACY AND VERSATILITY. THE ACCURACY GOAL OF THIS SIGHT IS TOR=05 MIL.					MAY 80
0 78 5071 41	MICROMAVE SKY SCREEN TASK WAS TERMINATED AND FUNDS WERE REALLOCATED. SUFFICIENT TECHNICAL PERSONNEL WERE NOT AVAILABLE TO ACCOMPLISH THE PLANNED WORK.					MAY 80
0 78 5071 42	IMPROVED CRUSHER GAGES COMPARATIVE PRESSURE TESTS OF THE NEW GAGES AND MILL CRUSHER GAGE ARE IN PROGRESS. UPON COMPLETION OF THESE TESTS, FIELD WEAPON TESTS INCLUDING HIGH AND LOW TEMPERATURES ARE PLANNED.					MAY 80
0 78 5071 43	TEST AUTOMATION DEVELOPMENT WORK HAS STARTED IN THE FOLLOWING AUTOMATION AREAS. A. AVIONICS TEST AUTOMATION. B. ANTENNA PATTERN AUTOMATION. C. SCIENTIFIC AND ENGINEERING PROCESSING. D. TEST SITE TEST AUTOMATION. OTHER AREAS THAT REQUIRE AUTOMATION HAVE BEEN IDENTIFIED.					MAY 80
0 78 5071 45	AEROSOL BIOLOGICAL PARTICLE SIZE MEAS. STANDARDIZATION THE REQ PPSNEL TRAINING HAS BEEN COMPLETED. AS A RESULT, AGREEMENT BETWEEN VISUAL AND AUTOMATIC COUNTING AND SIZING OF PARTICLES HAS BEEN ACHIEVED AND A DATA REDUCTION SYSTEM WITH A COMPUTER HAS BEEN ESTABLISHED.					MAY 80

SUMMARY PROJECT STATUS REPORT
 MANUFACTURING METHODS AND TECHNOLOGY PROGRAM
 2ND SEMIANNUAL SUBMISSION CY 79 HCS DRCHT-301

PROJ NO.	TITLE + STATUS	AUTHORIZED (\$000)	CONTRACT VALUES (\$000)	EXPENDED LABOR AND MATERIAL (\$000)	ORIGINAL PROJECTED COMPLETE DATE	PRESENT PROJECTED COMPLETE DATE
0 78 5071 46	FERMENTATION METHODOLOGY SUCCESSFUL REACTIVATION OF FERMENTOR AND REPLACEMENT OF NEEDED PARTS AND REPAIRS IN THE FERMENTATION FACILITY WERE ACCOMPLISHED. SIX LOTS OF S. MARCESCENS, TWO LOTS OF E. COLI AND ONE EXPERIMENTAL LOT OF MS-2 COLIPHAGE WERE PRODUCED.	(9000)				MAY 80
0 78 5071 47	AVIRULENT VEE VIRUS STRAIN STANDARDIZATION SOME SUCCESS HAS BEEN ACHIEVED IN ESTABLISHING A CONTINUOUS CELL SYSTEM. VERO CELLS WERE ESTABLISHED. THE BAKER LABORATORY FUNCTION IS PLANNED TO BE RELOCATED TO THE DPG CHEMISTRY COMPLEX.					MAY 80
0 78 5071 48	TANK MAIN WEAPON FIRING INHIBITOR AN OPTICAL INHIBITOR SYSTEM USING DETECTION OF CODED LIGHT HAS BEEN DESIGNED. A BREADBOARD MODEL HAS DEMONSTRATED THE EFFECTIVENESS FOR 2000M. THE RANGE REQ HAS BEEN EXTENDED TO 3000M. A REDESIGN USING LASER DIODES IS UNDERWAY TO ACHIEVE THIS RANGE.					MAY 80
0 78 5071 49	IMPROVED TRANSPORTABILITY/CONTAINER TEST CAPABILITY PRELIMINARY PLANS AND COST ESTIMATES HAVE BEEN COMPLETED FOR THE LANDSHIP MATERIAL HANDLING TEST FACILITY. PREPARATION OF THE CONSTRUCTION DOCUMENTS ARE IN PROGRESS. THIS TASK WAS TEMPORARILY SUSPENDED WHEN THE P.I. WAS TRANSFERRED.					MAY 80
0 79 5071	TECON TEST METHODOLOGY ENGINEERING MEASURES SEE SUBTASKS BELOW FOR PROJECT STATUS.	981.0	57.0	329.7	SEP 80	DEC 80
0 79 5071 01	ACCEPTANCE TEST PROCEDURES FOUR ATPS WERE PREPARED BY OTHER AGENCIES AND REVIEWED FOR TECHNICAL CONTENT. TWO ATPS WERE PREPARED BY APG AND PUBLISHED. THOSE PUBLISHED COVERED THE ACCEPTANCE TESTING OF THE 4.2-INCH MORTAR AND 81-MM MORTAR.				SEP 80	DEC 80
0 79 5071 10	TEST OPERATION PROCEDURES ELEVEN TOPS WERE PUBLISHED. TWELVE ARE AWAITING PUBLICATION. TWENTY THREE ARE IN THE PROCESS OF BEING WRITTEN.				SEP 80	DEC 80
0 79 5071 50	TOXIC GAS MEASUREMENTS DURING WEAPON FIRINGS WEAPONS AND AMMUNITION WERE OBTAINED AND PLANS COMPLETED FOR TEST FIRINGS FROM AN M60A1 TANK. A TEST MATRIX HAS BEEN DESIGNED WHICH WILL ASSESS TOXIC-GAS BUILDUP WHILE FIRING FROM BOTH A STATIONARY AND MOVING VEHICLE.				SEP 80	DEC 80
0 79 5071 51	SAFETY EVALUATION OF AMMUNITION APG INVESTIGATIONS OF SECURED CARGO VIBRATION TEST IS NOT AN ADEQUATE SIMULATION OF THE ACTUAL TRANSPORT ENVIRONMENT OF MILITARY MUNITIONS. SUBSEQUENT INVESTIGATION ARE SCM, TO IDENTIFY ACTUAL TRANSPORT ENVIRONMENT.				SEP 80	DEC 80

MANUFACTURING METHODS AND TECHNOLOGY PROGRAM
 S U M M A R Y P R O J E C T S T A T U S R E P O R T
 2ND SEMI-ANNUAL SUBMISSION CY 79 RCS DRCHT-301

PROJ NO.	TITLE + STATUS	AUTHORIZED (\$000)	CONTRACT VALUES (\$000)	EXPENDED LABOR AND MATERIAL (\$000)	ORIGINAL PROJECTED COMPLETE DATE	PRESENT PROJECTED COMPLETE DATE
0 79 5071 52	SHOCK AND BLAST EFFECTS FROM STABALLOY PENETRATION THE LITERATURE SEARCH WAS COMPLETED. A TEMPORARY ENCLOSURE WAS CONSTRUCTED AND INSTRUMENTED TO TEST SHOCK AND BLAST LEVELS OF THE STABALLOY PROJECTILES ON ARMOR TARGETS.				SEP 80	DEC 80
0 79 5071 53	CERTIFICATION OF LOOSE CARGO BOUNCE TEST AN UNSOLICITED PROPOSAL WAS RECEIVED TO CONDUCT THIS WORK.				SEP 80	DEC 80
0 79 5071 54	ON-LINE SEMI CONDUCTOR TESTING IN NUCLEAR ENVIRONMENT NO EFFORT HAS BEEN EXPENDED ON THIS EFFORT SINCE LAST REPORT DUE TO LACK OF AVAILABLE PERSONNEL.				SEP 80	DEC 80
0 79 5071 55	FAST BURST REACTOR EFFORT HAS BEEN DEVOTED TO THE EVALUATION OF THE EFFECTS OF REFLECTING MATERIALS ON THE OUTPUT CHARACTERISTICS OF REACTORS, PARTICULARLY THE ROLE OF VARIOUS REFLECTORS IN CHANGING THE NATURE OF THE OUTPUT RADIATION FROM THE CORE.				SEP 80	DEC 80
0 79 5071 56	LIDAR FEASIBILITY TEST TESTS WERE CONDUCTED TO MEASURE SMOKE/OBSCURANT CHARACTERISTICS AND BEHAVIOR, DURING THESE TEST, LIDAR TYPE EQUIPMENT WAS OPERATED.				SEP 80	DEC 80
0 80 5071	PRODUCTION TEST METHODOLOGY THIS PROJECT WAS JUST FUNDED. NO STATUS REPORT IS REQUIRED.			622.0		

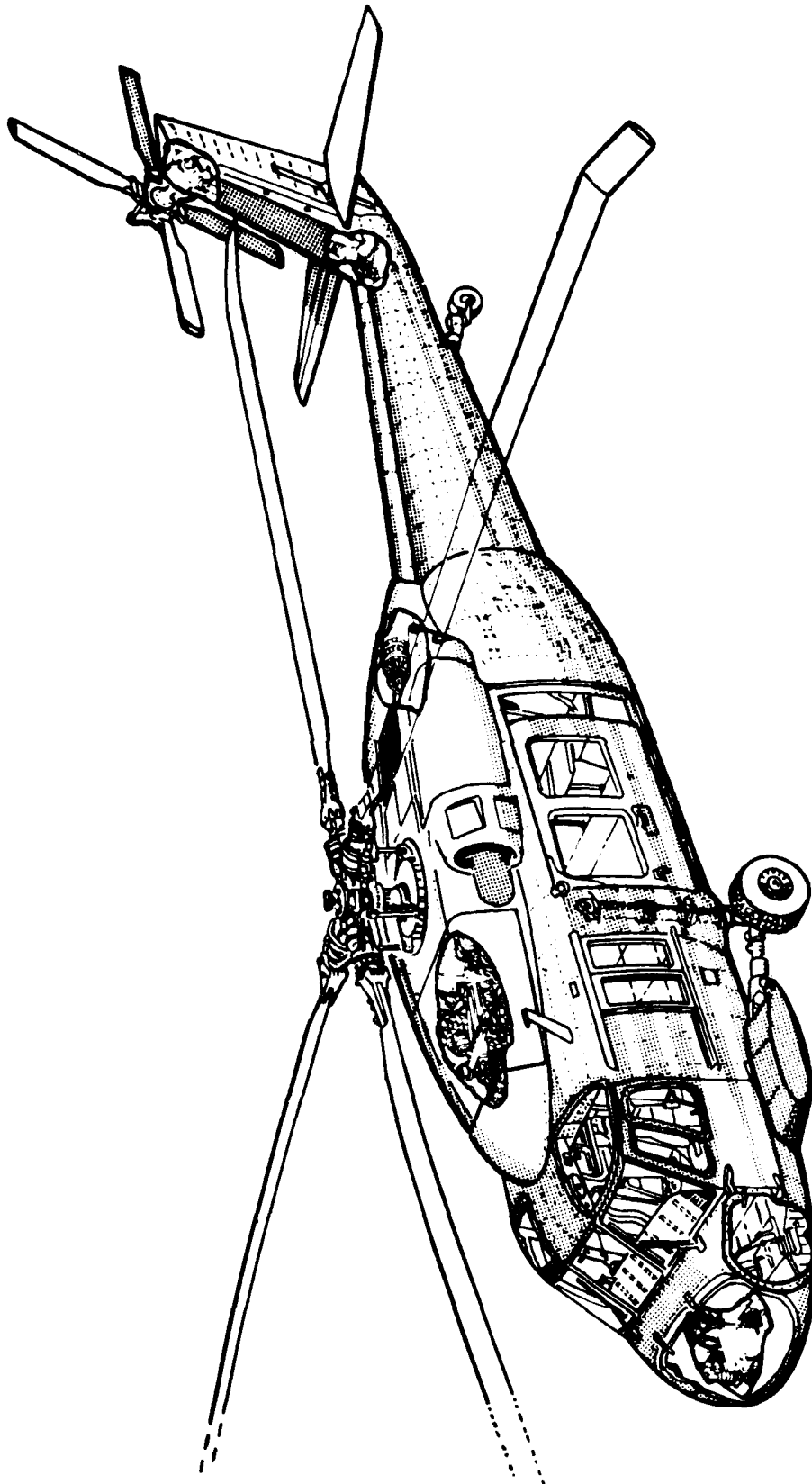

AVIATION R&D COMMAND
(AVRADCOM)

A V I A T I O N R + D C O M M A N D
CURRENT FUNDING STATUS, 2ND CY79

FISCAL YEAR	NO. OF PROJECTS	AUTHORIZED FUNDS (\$)	C O N T R A C T A L L O C A T E D (\$)	F U N D I N G E X P E N D E D (\$)	I N M O U S E R E M A I N I N G (\$)	F U N D I N G E X P E N D E D (\$)
74	1	125,000	97,000	30,000 (30%)	28,000	28,000 (100%)
75	7	1,436,900	990,400	853,600 (86%)	446,500	409,500 (91%)
76	6	1,220,000	586,700	433,000 (73%)	633,300	465,300 (73%)
77	0	0	0	0 (0%)	0	0 (0%)
77	10	2,072,600	853,900	452,300 (52%)	1,218,700	829,900 (68%)
78	19	3,761,000	2,019,700	407,800 (20%)	1,741,300	600,700 (34%)
79	27	7,741,600	4,615,300	894,200 (19%)	3,126,300	533,100 (17%)
80	23	8,859,500	0	0 (0%)	8,859,500	0 (0%)
81	0	0	0	0 (0%)	0	0 (0%)
82	0	0	0	0 (0%)	0	0 (0%)
TOTAL	93	25,216,600	9,163,000	3,070,900 (33%)	16,053,600	2,866,300 (17%)

AUTHORIZED FUNDING CONTRACT ALLOCATED 36% INHOUSE REMAINING 63%

S U M M A R Y P H O J E C T S T A T U S R E P O R T
 2ND SEMI ANNUAL SUBMISSION CY 79 MCS DRCMT-301

MANUFACTURING METHODS AND TECHNOLOGY PROGRAM

PROJ NO.	TITLE + STATUS	AUTUMN- RIZED (\$000)	CONTRACT VALUES (\$000)	EXPENDED LABOR AND MATERIAL (\$000)	ORIGINAL PROJECTED COMPLETE DATE	PRESENT PROJECTED COMPLETE DATE
1 78 7036	ISOTHERMAL ROLL-FORGING OF COMPRESSOR BLADES ***** DELINQUENT STATUS REPORT *****	300.0	250.0	49.0	JUN 79	JUN 80
1 79 7036	ISOTHERMAL ROLL-FORGING OF COMPRESSOR BLADES ***** DELINQUENT STATUS REPORT *****	275.0		1.6		
1 76 7042	MICROWAVE CURE OF COMPOSITE ROTOR BLADE SPARS ***** DELINQUENT STATUS REPORT *****	250.0	50.0	136.0	FEB 77	JUN 80
1 75 7052	FEAS OF ULTRASONIC ASSISTED FORMATION OF TITANIUM NOSE CAP ***** DELINQUENT STATUS REPORT *****	209.4	171.4	38.0	JUN 76	JUN 80
1 77 7052	FEAS OF ULTRASONIC ASSISTED FORMATION OF TITANIUM NOSE CAP ***** DELINQUENT STATUS REPORT *****	556.0	347.3	86.0	SEP 79	APR 81
1 80 7052	ULTRASONICALLY-ASSISTED COLD FORMING OF TITANIUM NOSE CAPS FUNDS OF 180,000 DOLLARS BEING FORWARDED TO AMMRC.	200.0			APR 80	APR 80
1 78 7055	ULTRASONIC WELDING OF HELICOPTOR FUSELAGE STRUCTURES ***** DELINQUENT STATUS REPORT *****	441.0			JAN 79	DEC 80
1 75 7070	CAST COMPRESSOR COMPONENTS ***** DELINQUENT STATUS REPORT *****	195.0	171.3	23.7	OCT 77	JUN 80
1 76 7079	BRAIDING OF REINFORCED PLASTIC STRUCTURAL COMPONENT ***** DELINQUENT STATUS REPORT *****	156.0	139.6	16.4	JAN 78	JUN 80
1 78 7086	ABRADABLE SEALS FOR COMPRESSOR BLADE TIP APPLICATIONS ***** DELINQUENT STATUS REPORT *****	91.0	72.4	10.7	JUN 79	JUN 80
1 79 7086	ARMADABLE SEALS FOR COMPRESSOR BLADE TIP APPLICATIONS ***** DELINQUENT STATUS REPORT *****	90.0		6.3	SEP 80	SEP 80
1 78 7091	PROCESSING AIRCRAFT COMPONENTS USING PULTRUDED MATERIALS ***** DELINQUENT STATUS REPORT *****	320.0	150.0	112.3	SEP 80	AUG 80
1 77 7104	T700 TURBINE ENGINE NOZZLE MANUFACTURING PROCESS ***** DELINQUENT STATUS REPORT *****	33.4	33.2		JUN 79	JUN 80
1 78 7104	T700 TURBINE ENGINE NOZZLE MANUFACTURING PROCESS ***** DELINQUENT STATUS REPORT *****	32.0	23.7	8.3	MAR 78	JUN 80
1 77 7108	MANUFACTURING TECHNIQUES FOR TRANSMISSION SHAFT SEALS CARBON RINGS AND GATEW SPRINGS HAVE BEEN FABRICATED, BUT PROBLEMS WITH VARIABLE SHRINKAGE RATES IN THE ELASTOMERIC MOLDING PROCESS HAVE BEEN EXPERIENCED. THE TEST HEADS AND THE INSPECTION AND ASSEMBLY FIXTURES ARE READY FOR USE.	135.0	111.8	13.5	AUG 79	JUN 80

SUMMARY PROJECT STATUS REPORT
2ND SEMI-ANNUAL SUBMISSION CY 79 RCS DRCHT-301

MANUFACTURING METHODS AND TECHNOLOGY PROGRAM

PROJ NO.	TITLE + STATUS	AUTHORIZED (\$000)	CONTRACT VALUES (\$000)	EXPENDED LABOR AND MATERIAL (\$000)	ORIGINAL PROJECTED COMPLETE DATE	PRESENT PROJECTED COMPLETE DATE
1 79 7113	COMPOSITE FUSELAGE MANUFACTURING TECHNOLOGY ***** DELINQUENT STATUS REPORT *****	250.0	200.0	33.0	SEP 80	SEP 81
1 80 7113	COMPOSITE REAR FUSELAGE MANUFACTURING TECHNOLOGY FUNDS ARE IN THE PROCESS OF BEING FORWARDED TO ATL.	1,000.0				
1 76 7114	IMPROVED MFG TECH FOR INFRARED SUPPRESSION ON AIRCRAFT ***** DELINQUENT STATUS REPORT *****	79.0		79.0	SEP 77	JUN 80
1 77 7114	MFG TECHNIQUES FOR INFRARED SUPPRESSION AIRCRAFT COMPONENTS ***** DELINQUENT STATUS REPORT *****	264.0	95.0	164.0	APR 78	JUN 80
1 77 7119	NON-DESTRUCTIVE EVALUATION TECH FOR COMPOSITE STRUCTURES ***** DELINQUENT STATUS REPORT *****	475.0	17.6	435.1	SEP 80	JUN 80
1 78 7119	NON-DESTRUCTIVE EVALUATION TECH FOR COMPOSITE STRUCTURES ***** DELINQUENT STATUS REPORT *****	96.0		91.1	SEP 80	JUN 80
1 79 7119	NON-DESTRUCTIVE EVALUATION TECH FOR COMPOSITE STRUCTURES ***** DELINQUENT STATUS REPORT *****	400.0	160.0	42.7	JUN 80	JUN 80
1 80 7119	NON-DESTRUCTIVE EVAL TECHNIQUES FOR COMPOSITE STRUCTURES PROJECT FUNDS WERE JUST RELEASED.	400.0				
1 78 7121	INTEGRALLY HEATED + PRESSURIZED TOOLING F/UTIAS MOTOR BLADES ***** DELINQUENT STATUS REPORT *****	234.0	125.0	7.7	JUN 79	SEP 80
1 78 7123	CONTINUOUS BALANCING OF HELICOPTOR SHAFTING ***** DELINQUENT STATUS REPORT *****	120.0	90.0	10.0	JUN 79	JUN 80
1 77 7144	T700 ENGINE NOZZLE IMPROCESS INSPECTION ***** DELINQUENT STATUS REPORT *****	66.6	59.0	8.6	APR 79	OFC 80
1 78 7144	T700 ENGINE NOZZLE IMPROCESS INSPECTION ***** DELINQUENT STATUS REPORT *****	67.0	65.8	1.2	NOV 79	JUN 80
1 78 7155	MFG METHODS FOR IMPROVED HIGH PERFORMANCE HELICOPTER GEARS ***** DELINQUENT STATUS REPORT *****	461.0	360.0	57.4	NOV 80	AUG 81
1 80 7155	COST EFFECTIVE MANUFACTURING METHODS FOR HELICOPTER GEARS FUNDS ARE BEING TRANSFERRED TO AMARC.	200.0				
1 76 7156	ULTRASONICALLY ASSISTED MACHINING FOR SUPERALLOYS. ***** DELINQUENT STATUS REPORT *****	300.0	207.1	72.9	MAY 78	JUN 80

S U M M A R Y P R O J E C T S T A T U S R E P O R T
 2ND SEMIANNUAL SUBMISSION CY 79 RCS DRCT-301

PROJ NO.	TITLE * STATUS	AUTHORIZED (\$000)	CONTRACT VALUES (\$000)	EXPENDED LABOR AND MATERIAL (\$000)	ORIGINAL PROJECTED COMPLETE DATE	PRESENT PROJECTED COMPLETE DATE
1 78 7183	SEMI-AUTO COMPOSITE MFG SYS- HELICOPTER FUSELAGE STRUCTURES ***** DELINQUENT STATUS REPORT *****	245.0	191.0	54.0	MAR 81	JUN 80
1 79 7183	SEMI-AUTO COMPOSITE MFG SYS-HELICOPTER FUSELAGE STRUCTURES ***** DELINQUENT STATUS REPORT *****	100.0	80.0	5.0	MAY 81	MAY 81
1 80 7183	SEMI-AUTO COMPOSITE MANUFAC SYSTEM HELICOPTER SECONDARY STRU FUNDS ARE IN THE PROCESS OF BEING FORWARDED TO ATL.	155.0				
1 77 7197	FABRICATION OF INTEGRAL ROTORS BY JOINING ***** DELINQUENT STATUS REPORT *****	300.0	240.0	55.0	DEC 80	JUN 80
1 79 7197	FABRICATION OF INTEGRAL ROTORS BY JOINING ***** DELINQUENT STATUS REPORT *****	100.0				
1 80 7197	FABRICATION OF INTEGRAL ROTORS BY JOINING FUNDS OF 100,000 DOLLARS BEING FORWARDED TO THE APPLIED TECHNOLOGY LAB.	100.0			SEP 81	SEP 81
1 78 7199	LASER HARDENING OF GEARS, BEARINGS AND SEALS ***** DELINQUENT STATUS REPORT *****	180.0	100.0	28.0	SEP 78	JUN 80
1 79 7199	LASER HARDENING OF GEARS, BEARINGS AND SEALS ***** DELINQUENT STATUS REPORT *****	200.0	200.0		UCT 80	OCT 81
1 80 7199	SURFACE HARDENING OF GEARS, BEARINGS AND SEALS BY LASERS FUNDS OF 225,000 DOLLARS ARE BEING FORWARDED TO ATL AT FT EUSTIS.	250.0			SEP 81	SEP 81
1 79 7200	COMPOSITE ENGINE INLET PARTICLE SEPARATOR ***** DELINQUENT STATUS REPORT *****	400.0		38.0	SEP 80	SEP 80
1 80 7200	COMPOSITE ENGINE INLET PARTICLE SEPARATOR FUNDS ARE IN THE PROCESS OF BEING FORWARDED TO ATL.	100.0				
1 79 7202	APPLICATION OF THERMOPLASTICS ***** DELINQUENT STATUS REPORT *****	202.5	164.5	37.5	JUN 80	JUN 80
1 80 7202	APPLICATION OF THERMOPLASTICS TO HELICOPTER SECONDARY STRUCS FUNDS ARE IN THE PROCESS OF BEING FORWARDED TO ATL.	225.0				
1 77 7236	PRECISION FORGED ALUMINIUM POUWER METALLURGY PAPER PRODUCTION, VACUUM SYSTEM CONSTRUCTION, DURABILITY ANALYSIS, AND PROCESS OPTIMIZATION WAS COMPLETED. WORK WAS STARTED ON THE PROTOTYPE FURGING PHASE.	72.6	50.0	21.4	MAR 79	MAR 80

S U M M A R Y P H O J E C T S T A T U S R E P O R T
2ND SEMIANNUAL SUBMISSION CY 79 RES DRCMT-301

PROJ NO.	TITLE + STATUS	AUTOMATIZED (\$000)	CONTRACT VALUES (\$000)	EXPENDED		PRESENT PROJECTED COMPLETE DATE
				LABOR AND MATERIAL (\$000)	ORIGINAL PROJECTED COMPLETE DATE	
1 79 7238	PRECISION FORGED ALUMINUM POWDER METALLURGY EFFORTS TO SELECT A HELICOPTER SUB CONTRACTOR ARE STILL IN PROGRESS.	398.7	350.0	27.9	APR 81	APR 81
1 78 7240	ESR 4340 MACHINING METHODS FOR HELICOPTER APPLICATIONS ***** DELINQUENT STATUS REPORT *****	130.0	98.5	20.7	SEP 78	JUN 80
1 79 7240	ESR 4340 MACHINING METHODS FOR HELICOPTER APPLICATIONS ***** DELINQUENT STATUS REPORT *****	75.0	47.6		AUG 80	AUG 80
1 80 7240	MACHINING METHODS FOR ESK 4340 STEEL FOR HELICOPTER APPL. FUNDS ARE BEING TRANSFERRED TO AMRC.	124.0				
1 78 7241	HOT ISOSTATIC PRESSING OF TITANIUM CASTINGS ***** DELINQUENT STATUS REPORT *****	113.0	100.0	13.0	MAR 79	
1 79 7241	HOT ISOSTATIC PRESSING OF TITANIUM CASTINGS ***** DELINQUENT STATUS REPORT *****	600.0	520.0		SEP 81	SEP 81
1 80 7241	HOT ISOSTATIC PRESSES TITANIUM FUNDS OF 100,000 DOLLARS ARE BEING FORWARDED TO AMRC.	250.0			JUL 80	JUL 80
1 79 7243	MACHINING OPERATIONS ON KEVLAR LAMINATED CONSTRUCTIONS ***** DELINQUENT STATUS REPORT *****	104.0	87.0		NOV 79	JUN 80
1 80 7243	MACHINING OPERATIONS ON KEVLAR LAMINATED CONSTRUCTIONS FUNDS ARE IN THE PROCESS OF BEING FORWARDED TO ATL.	150.0				
1 77 7258	THIN WALL MANTECH FUM RPV SENSOR DOWES ***** DELINQUENT STATUS REPORT *****	35.0		16.2	AUG 80	JUN 80
1 77 7281	SURVEY OF COMPOSITE MANTECH F/ARMY AIRCRAFT STRUCTURES ***** DELINQUENT STATUS REPORT *****	135.0	100.0	30.1	SEP 78	JUN 80
1 78 7284	SUPERPLASTIC FUMMING/DIFFUSION BONDING OF TITANIUM ***** DELINQUENT STATUS REPORT *****	120.0	118.3		JUL 81	UCT 81
1 79 7284	SUPERPLASTIC FUMMING/DIFFUSION BONDING OF TITANIUM ***** DELINQUENT STATUS REPORT *****	400.0	322.2	70.0	UCT 82	UCT 82
1 78 /285	CAST TITANIUM COMPRESSOR IMPELLERS ***** DELINQUENT STATUS REPORT *****	135.0	100.0	29.0	JUN 78	JUN 80
1 79 7285	CAST TITANIUM COMPRESSOR IMPELLERS ***** DELINQUENT STATUS REPORT *****	300.0	200.0	10.0	FEB 80	JUN 80

MANUFACTURING METHODS AND TECHNOLOGY PROGRAM
 SUMMARY PROJECT STATUS REPORT
 2ND SEMIANNUAL SUBMISSION CY 79 RCS DRCHT-301

PROJ NO.	TITLE + STATUS	AUTHORIZED (\$000)	CONTRACT VALUE (\$000)	EXPENDED LABOR AND MATERIAL (\$000)	ORIGINAL PROJECTED COMPLETE DATE	PRESENT PROJECTED COMPLETE DATE
1 80 7285	CAST TITANIUM COMPRESSOR IMPELLERS FUNDS OF 270,000 DOLLARS ARE BEING FORWARDED TO ATL.	300.0			SEP 81	SEP 81
1 78 7286	SUPERALLOY POWDER PRODUCTION FOR TURBINE COMPONENTS ***** DELINQUENT STATUS REPORT *****	220.0	175.0	41.0	SEP 79	FEB 81
1 79 7286	SUPERALLOY POWDER PRODUCTION FOR TURBINE COMPONENTS ***** DELINQUENT STATUS REPORT *****	322.0	210.0	35.0	FEB 81	FEB 81
1 80 7286	HIGH QUALITY SUPERALLOY POWDER PRODUCTION FOR TURB. COMP. FUNDS OF 11,000 DOLLARS ARE BEING FORWARDED TO AMMRC.	120.0			MAR 81	MAR 81
1 78 7287	PRODUCTION METHODS FOR MULTI-ELEMENT MODULES FOR ANTENNAS ***** DELINQUENT STATUS REPORT *****	240.0		58.0	DEC 80	DEC 80
1 79 7287	PRODUCTION METHODS FOR MULTI-ELEMENT MODULES FOR ANTENNAS ***** DELINQUENT STATUS REPORT *****	225.0		24.0	DEC 81	DEC 81
1 79 7288	OPTIMAL CURING COND. FOR PROCESS FIBER-REINFORCED COMPOSITES ***** DELINQUENT STATUS REPORT *****	112.5		2.6	MAY 80	JUN 80
1 80 7288	DETERMINATION OF OPTIMAL CURING CONDITIONS FOR COMPOSITES FUNDS ARE IN THE PROCESS OF BEING FORWARDED TO AMMRC.	200.0				
1 79 7291	TITANIUM POWDER METAL COMPRESSOR IMPELLER ***** DELINQUENT STATUS REPORT *****	240.0		25.0	SEP 80	SEP 80
1 80 7291	TITANIUM POWDER METAL COMPRESSOR IMPELLER FUNDS IN THE AMOUNT OF 216000 DOLLARS HAVE BEEN FORWARDED TO THE APPLIED TECHNOLOGY LAB AT FORT EUSTIS	240.0			JUN 81	JUN 81
1 79 7292	IMPROVED PROC TO REDUCE COST OF TESTING MICROPROCESSOR ***** DELINQUENT STATUS REPORT *****	53.4				
1 80 7292	MICROPROCESSOR AND LSI FAULT ISOLATION AND TESTING FUNDS ARE BEING RETAINED AT AVRADCOM FOR PROBABLE REPROGRAMMING LATER IN FY80. THE EFFORT ORIGINALLY SCHEDULED FOR THE FY80 EFFORT IS BEING RESCHEDULED FOR FY81.	150.0				
1 79 7297	PROD-INSTALL OF URETHANE EDGE GUARDS ON ROTOR BLADES ***** DELINQUENT STATUS REPORT *****	183.0		11.3	JUN 80	JUN 80
1 79 7298	HIGH TEMPERATURE VACUUM CARBURIZING ***** DELINQUENT STATUS REPORT *****	125.0	100.0	0.7		

MANUFACTURING METHODS AND TECHNOLOGY PROGRAM
 S U M M A R Y P R O J E C T S T A T U S R E P O R T
 2ND SEMIANNUAL SUBMISSION CY 79 RCS DRCMT-301

PROJ NO.	TITLE + STATUS	AUTHORIZED (\$000)	CONTRACT VALUES (\$000)	EXPENDED LABOR AND MATERIAL (\$000)	ORIGINAL PROJECTED COMPLETE DATE	PRESENT PROJECTED COMPLETE DATE
1 80 7298	HIGH TEMPERATURE VACUUM CARRORIZING 14000 DOLLARS BEING FORWARDED TO AMHRC.	150.0			SEP 80	SEP 80
1 79 7315	LHM GUST MANUFACTURE OF POISE GIMBAL ***** DELINQUENT STATUS REPORT *****	202.0		10.7		
1 79 7338	COMPOSITE TAIL SECTION PROGRAM IS BEING HELD IN ABEYANCE PENDING A REDESIGN OF THE TAIL SECTION BY HUGHES HELICOPTER.	980.0	893.0	87.0	JUL 80	JUL 80
1 80 7338	COMPOSITE TAIL SECTION FUNDS ARE IN THE PROCESS OF BEING FORWARDED TO THE CONTRACTING OFFICER AND SUPPORTING ACTIVITIES.	975.0				
1 79 7339	FILAMENT WOUND COMPOSITE FLEXBEAM TAIL ROTOR FABRICATION REFINEMENT AND TOOL DESIGN HAVE BEEN COMPLETED.	452.0	442.0		AUG 80	AUG 80
1 80 7339	FILAMENT WOUND COMPOSITE FLEXBEAM TAIL ROTOR FUNDS ARE IN THE PROCESS OF BEING FORWARDED TO THE CONTRACTING OFFICER AND TO THE SUPPORTING ACTIVITIES.	1,355.0				
1 79 7340	COMPOSITE MAIN ROTOR BLADE FIVE BLADES HAVE BEEN FABRICATED. ONLY MINOR CHANGES WERE REQUIRED IN THE TOOLING AND PROCEDURE AFTER BLADE 1. SECTIONING AND INSPECTION OF BLADE 2 SHOWED THE BLADE TO BE STRUCTURALLY SOUND AND DIMENSIONALLY ACCURATE. STRUCTURAL TESTING WILL BE NEXT.	739.0	639.0	100.0	NOV 80	JUN 80
1 80 7340	COMPOSITE MAIN ROTOR BLADE FUNDS IN THE AMOUNT OF \$2030K ARE IN THE PROCESS OF BEING FORWARDED TO THE CONTRACTING OFFICER AND SUPPORTING ACTIVITIES.	2,030.5				
1 80 7341	STRUCTURAL COMPOSITES FABRICATION GUIDE FUNDS ARE BEING RETAINED AT AVRADCOM FOR OBLIGATION UP REPROGRAMMING LATER IN THE YEAR.	70.0				
1 80 7342	PULTRUSION OF MONOCOMB SANDWICH PANELS FUNDS IN THE AMOUNT OF \$12,000 ARE IN THE PROCESS OF BEING TRANSFERRED TO AMHRC.	115.0				
1 78 7348	LHM COMPOSITE FASTENING SYS FOR COMPOSITE HELICOPTER COMPTS ***** DELINQUENT STATUS REPORTS *****	216.0		20.0	JUN 80	JUN 80
1 79 7371	INTEGRATED BLADE INSPECTION SYSTEM (IBIS) A MILITARY INTERDEPARTMENTAL PURCHASE REQUEST (MIPR) WAS FORWARDED TO THE AIR FORCE APL. THIS PROJECT IS BEING JOINTLY FUNDED BY THE AIR FORCE AND ARMY.	212.5			MAR 82	MAR 82

MANUFACTURING METHODS AND TECHNOLOGY PROGRAM
 S U M M A R Y P R O J E C T S T A T U S R E P O R T
 2ND SEMIANNUAL SUBMISSION CY 79 RCS DRGMT-301

PROJ NO.	TITLE + STATUS	AUTHORIZED (\$000)	CONTRACT VALUES (\$000)	EXPENDED LABOR AND MATERIAL (\$000)	ORIGINAL PROJECTED COMPLETE DATE	PRESENT PROJECTED COMPLETE DATE
1 75 8017	EROSION RESISTANT LEADING EDGE FOR HELICOPTOR ROTOR BLADES ***** DELINQUENT STATUS REPORT *****	268.5	209.1	48.0	MAY 76	JUN 80
1 74 8035	PROD OF TRANSPARENT FORMS OF POLYOLEFIN FOR LTMT ARMOR APPLN ***** DELINQUENT STATUS REPORT *****	125.0	97.0	28.0	JUN 75	JUN 80
1 75 8035	PROD OF TRANSPARENT FORMS OF POLYOLEFIN FOR LTMT ARMOR APPLN ***** DELINQUENT STATUS REPORT *****	114.0	31.0	83.0	SEP 76	JUL 80
1 76 8045	FIBER-REINFORCE PLASTIC HELICOPTER TAIL ROTOR ASSEMBLY ***** DELINQUENT STATUS REPORT *****	285.0	156.0	49.0	FFB 7A	JUN 80
1 75 8120	IMPRVD HCPTR SKIN MATERIAL BY CNTRLD SOLIDIFICATION + TMT A DRAFT OF THE FINAL REPORT HAS BEEN RECD FROM THE CONTRACTOR AND IS BEING REVIEWED.	250.0	175.0	49.2	JUN 7A	APR 80
1 75 8129	COLUMBIUM ALLOY TURBINE ENGINE COMPONENTS ***** DELINQUENT STATUS REPORT *****	250.0	169.4	80.6	APR 7A	JUN 80
1 75 8136	HIGH STRENGTH FLEXIBLE CARGO RESTRAINT DEVICES ***** DELINQUENT STATUS REPORT *****	150.0	63.2	86.8	AUG 75	SEP 80
1 76 8140	PROCESSING ADVANCED GEAR MATERIALS ***** DELINQUENT STATUS REPORT *****	150.0	34.0	112.0	DEC 7A	JUN 80

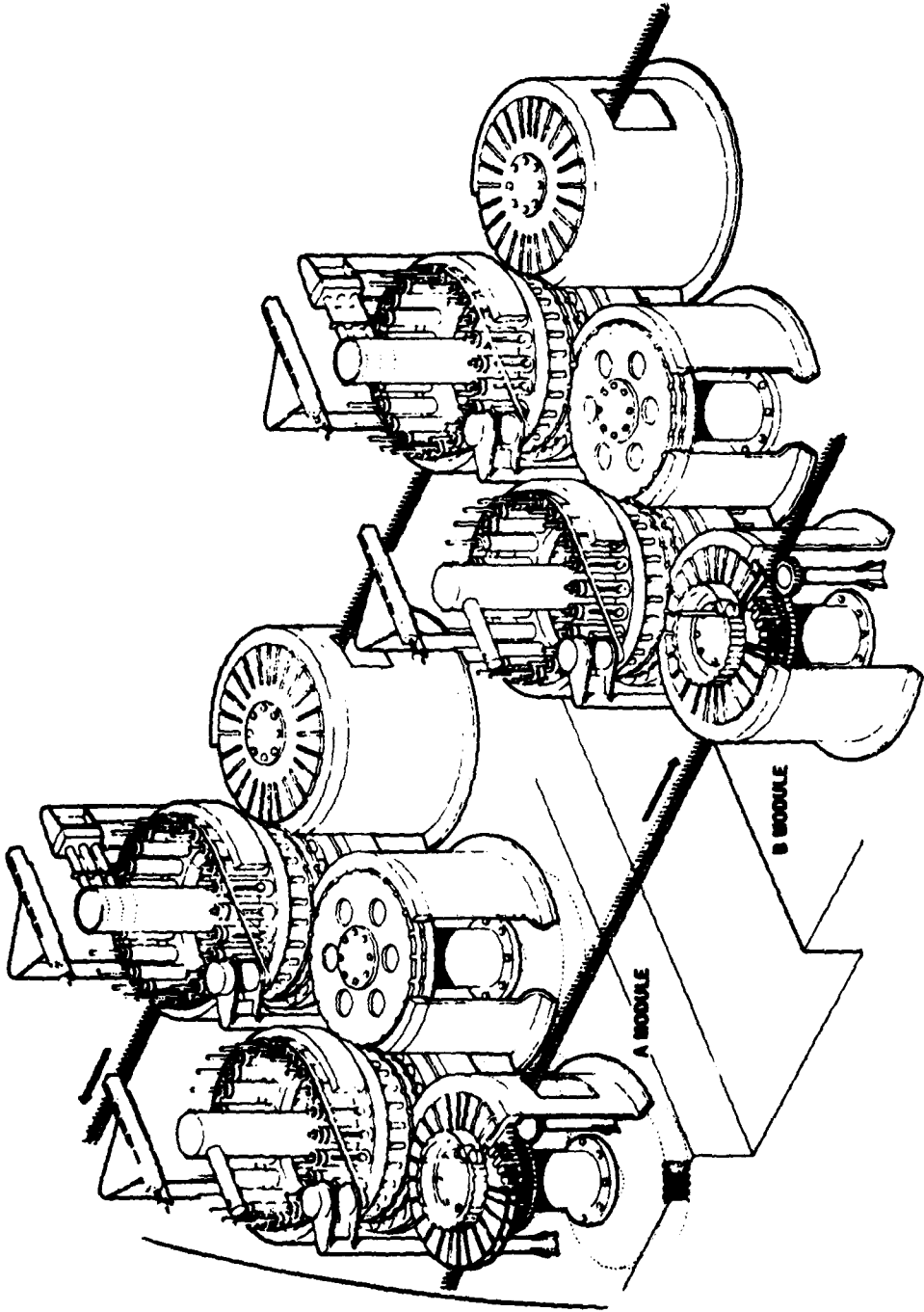

**ARMAMENT R&D COMMAND
ARMAMENT MATERIEL READINESS COMMAND
(ARRADCOM, ARRCOM)
(AMMUNITION)**

PRECEDING PAGE BLANK-NOT FILLED

A R R C O M - A R R A D C O M (AMMUNITION)

CURRENT FUNDING STATUS, 2ND CY79

FISCAL YEAR	NO. OF PROJECTS	AUTHORIZED FUNDS (\$)	* * ALLOCATED (\$)	C O N T R A C T F U N D I N G EXPENDED (\$)	* * REMAINING (\$)	I N H O U S E F U N D I N G EXPENDED (\$)
74	4	2,965,600	2,317,300	2,111,600 (91%)	644,300	614,900 (94%)
75	6	12,078,500	5,981,400	5,786,500 (96%)	6,097,100	3,492,300 (57%)
76	17	14,918,000	6,452,400	5,752,900 (89%)	8,485,600	5,965,300 (70%)
77	4	2,448,000	1,209,700	1,036,400 (85%)	1,238,300	737,300 (59%)
77	29	19,315,900	9,930,200	8,278,500 (83%)	9,385,700	6,683,900 (71%)
78	52	22,709,600	12,282,400	6,805,700 (55%)	10,427,200	7,170,000 (68%)
79	62	28,199,200	13,860,900	1,510,300 (10%)	14,338,300	4,892,600 (34%)
80	55	30,417,000	2,270,000	658,100 (28%)	28,147,000	449,000 (1%)
81	0	0	0	0 (0%)	0	0 (0%)
82	0	0	0	0 (0%)	0	0 (0%)
TOTAL	229	133,051,800	54,304,300	31,940,000 (58%)	78,747,500	30,005,300 (38%)

AUTHORIZED FUNDING CONTRACT ALLOCATED 41% INHOUSE REMAINING 59%

MANUFACTURING METHODS AND TECHNOLOGY PROGRAM
 S U M M A R Y P R O J E C T S T A T U S R E P O R T
 2ND SEMI-ANNUAL SUBMISSION CY 79 HCS DRCHT-303

PROJ NG.	TITLE * STATUS	AUTHO- RIZED (\$000)	CONTRACT VALUES (\$000)	EXPENDED LABOR AND MATERIAL (\$000)	ORIGINAL PROJECTED COMPLETE DATE	PRESENT PROJECTED COMPLETE DATE
5 80 0900	AUTOMATED MULTIPLE FILTER LIFE TESTER THIS PROJECT WAS JUST FUNDED. NO STATUS REPORT IS REQUIRED.	252.0				
5 80 1001	PILOT LINE FOR FUZE FLUIDIC POWER SUPPLIES THIS PROJECT WAS JUST FUNDED. NO STATUS REPORT IS REQUIRED.	253.0			MAY 81	MAY 81
5 80 1003	LOW COST MOLDED PACKAGING FOR HYBRID ELECTRONICS THE CONTRACT IS NOT YET AWARDED. PROJECT WILL APPLY INJECTION MOLDING, ENCAPSULATION AND SEALING TECHNIQUES USED FOR DUAL-IN-LINE PLASTIC PACKAGES TO LARGER HYBRID CIRCUITS. OBJECTIVE IS SHOCK AND SEALING PROTECTION FOR ELECTRONIC PROXIMITY FUSES.	243.0				
5 80 1005	CERAMIC-METAL SUBSTRATES FOR HYBRID ELECTRONICS THE CONTRACT IS NOT YET AWARDED. RFC BID PACKAGE IS SCHEDULED FOR RELEASE FEB 80. PROJECT WILL ESTABLISH PRODUCTION PROCESSES, RATES AND EQUIPMENT FOR BUILDING THICK FILM HYBRID CIRCUITS ON PORCELAIN-COATED STEEL SUBSTRATES.	319.0			OCT 81	OCT 81
5 75 1284	IMPROVEMENT * MOD OF INSP AIDS F/DEF * PROT ITEMS THE CONTRACTOR HAS PROVIDED ADDITIONAL FUNDING TO COMPLETE THE DOCUMENTATION. DRAFTS OF THE DOCUMENTATIONS HAVE BEEN REVIEWED. AN EVALUATION TEST PLAN HAS BEEN FINALIZED AND WILL BE EXECUTED DURING THE 2D FY80.	424.0	300.0	90.0	JUN 77	FEB 80
5 77 1295	MODERNIZATION OF CHARCOAL FILTER TEST EQUIPMENT SEE PROJECT NO 5 79 1295 FOR STATUS.	240.0	175.0	42.0	AUG 78	JUN 81
5 79 1295	MODERNIZATION OF CHARCOAL FILTER TEST EQUIPMENT THE DESIGN STUDY REPORT HAS BEEN COMPLETED. THE FILTER SYSTEM DESIGN IS CONTINUING. A FILTER SYSTEM DESIGN APPROACH INCLUDES A CONVEYOR * TRANSPORTER, HEAT SEALABLE DISPOSABLE CONTAINER AND FILTER PACKAGING.	860.0	550.0		DEC 80	JUN 81
6 78 1296	WT FOR CB FILTERS SP2 EVALUATION OF PERFORATED PLATE FILLING MACHINE COMPLETE. SP3 FILTER PULSE TESTING EMT BUILT AND INSTALLED. SP4 CONTRACT FOR DATA TO DETERMINE SAFE DUST LEVEL IN CHARCOAL FILTER MFG PLANTS IS 90 PERCENT COMPLETE.	654.0	318.4	335.6	MAR 79	DEC 79
5 79 1296	WT FOR CB FILTERS SP2 CONCEPT FOR SIDE-FILLING OF FILTER CELLS IDENTIFIED. BREADBOARD FILLING MACHINE HAS DESIGNED, BUILT, AND OPERATED. SP3 STUDIES ON ESTABLISHING VELOCITY TRANSVERSE AND LASER INDUCED FLUORESCENCE METHODS OF MEAS UNIFORMITY OF GAS PENETRATION.	400.0	75.0	266.5	MAY 80	DEC 80

S U M M A R Y P R O J E C T S T A T U S R E P O R T
2ND SEMI ANNUAL SUBMISSION CY 79 RCS ORCMT-301

PROJ NO.	TITLE + STATUS	AUTHORIZED (\$000)	CONTRACT VALUES (\$000)	EXPENDED LABOR AND MATERIAL (\$000)	ORIGINAL PROJECTED COMPLETE DATE	PRESENT PROJECTED COMPLETE DATE
5 80 1296	MANUFACTURING TECHNOLOGY FOR CB FILTERS THIS PROJECT WAS JUST FUNDED, NO STATUS REPORT IS REQUIRED.	404.0				
5 76 1311	M229 REFIL KIT COMPONENT-CHEMICAL AGENT ALARM ESSENTIALLY NO PROGRESS ON CONTRACT SINCE LAST STATUS RPT. ATTEMP REMENT WAS SENT LTR TO CTR, IND DESIGN LABS THAT CONTRACT MAY BE TERMINATED FOR DEFAULT.	570.0	177.0	362.0	DEC 77	OCT 80
5 77 1312	PAPER, CHEMICAL AGENT DETECTOR M8 ION RETENTION AIDS HAVE DETERMINED WHICH WILL DECREASE AMOUNT OF ONE LOST DURING DETECTOR PAPER FORMATION. METHODS OF INSURING ENVIRONMENTAL PROTECTION DURING PILOT PRODUCTION RUNS BEING DEVELOPED.	118.0		95.0	MAR 78	MAR 80
5 79 1318	CHEMICAL PRODUCTION FILL, CLUSE AND LAP FOR 8 IN XM736 PROJ EVALUATION OF POTENTIAL WASTE TREATMENT METHODS WAS INITIATED DURING THE PERIOD. M8S FOR THE PROJECT WAS ESTABLISHED.	398.0		1.0	MAR 81	OCT 80
5 80 1318	EST CHEMICAL PROD + FILL CLOSE + LAP TECH F/PROJ 811 VX-2 THIS PROJECT WAS JUST FUNDED. NO STATUS REPORT IS REQUIRED.	484.0				
5 77 1320	PILOT STATIONS FOR FILLING + CLOSING IMPROVED M8 MUNITIONS THE INERTIA WELDER WAS INSTALLED ON THE M8 DRY FILL LINE, THE ELECTRICAL AND HYDRAULIC HOOKUPS WERE COMPLETED. THE DRILL AND PIN MACHINE IS BEING FABRICATED. THE CONTRACTOR EXPECTS TO BE READY TO TEST THE MACHINE IN EARLY JAN 80.	374.0	257.0	116.0	JUL 78	JAN 80
5 78 1320	PILOT STATIONS FOR FILLING + CLOSING IMPROVED M8 MUNITIONS THE MACHINE TO TORQUE THE WARHEAD TO THE ROCKET MOTOR WAS REC'D BY PBA. A TRANSFER SYSTEM FOR THE LAP LINE IS BEING FABRICATED. EQUIPMENT INSTALLATION, DEBUGGING, AND ACCEPTANCE WILL SLIP 3 TO 4 MONTHS BECAUSE OF THE DELIVERY DATE OF THE D AND P MACH	375.0	47.0	144.0	SEP 79	JUN 80
5 77 1327	IMPROVEMENT AND MODERNIZATION OF GAS MASK LEAKAGE TESTING DESIGN REVIEW HELD ON TESTER AT SRI. CONTRACT AMENDED TO PERMIT TESTERS TO BE BUILT AS PROTOTYPES. WORK CONTINUED ON SHOP DRAWINGS, HAZARD ANALYSIS, TEST PLAN, AND INSTRUCTION MANUAL.	305.0	193.0	41.0	MAR 79	DEC 80
8 78 1335	M8 TECH FOR NEW PROTECTIVE MASK SRI'S PROTECTIVE MASK SOLICITATION HAVE BEEN EVALUATED. ADDITIONAL FUNDS WILL BE REQUIRED. PROCESS ENGINEERING WORK FOR COATING AUTOMATION COMPLETE. CONTINUING PREP OF WC PLAN.	724.0		214.5	JUN 79	JUN 81
5 79 1335	M8 TECH FOR NEW PROTECTIVE MASK SCOPE IS BEING REVISED AS A RESULT OF OCT 79 IPR. ADDITIONAL FUNDING WILL BE REQUIRED TO SUPPORT EXPANDED PILOT FACILITY.	629.0		336.6	OCT 82	OCT 82

S U M M A R Y P R O J E C T S T A T U S R E P O R T
2ND SEMI-ANNUAL SUBMISSION CY 79 RCS DRCMT-301

PROJ NO.	TITLE + STATUS	AUTHORIZED (\$000)	CONTRACT VALUES (\$000)	EXPENDED LABOR AND MATERIAL (\$000)		PRESENT PROJECTED COMPLETE DATE
				ORIGINAL PROJECTED COMPLETE DATE	EXPENDED LABOR AND MATERIAL (\$000)	
8 78 1339	PREPARATION OF 8-1 DYE EQUIPMENT TO PRODUCE 8-1 DYE USING THE TUBIAS ACID PROCESS HAS BEEN INSTALLED. PARTICLE ANALYSIS OF THE SPRAY DRIED 8-1 DYE HAS INDICATED THAT IT IS FINER THAN REQUIRED.	461.0	44.0	384.0	JUN 79	MAR 80
8 78 1345	BIOLOGICAL MARKING SYSTEM PEEL STRENGTH AND ALIGNMENT TESTS FOR THE TAPE HAVE BEEN DEVELOPED BY SRI. TAPE MARKING EQUIPMENT HAS BEEN INSTALLED BY INTER-MARK. BE-DIX EPID HAS EXPERIENCED DELAYS IN OBTAINING 3M19 BREADBOARDS. TAPE CASSETTE AND CEM 810 STERILITY STUDIES COMPLETE.	480.0	237.0	210.0	JAN 80	JUN 80
5 79 1345	BIOLOGICAL MARKING SYSTEM CHEMILUMINESCENCE CELL FABRICATED BY CSC. ALL PARTS FOR INJECTOR PUMP RECEIVED EXCEPT MANIFOLD BLOCK. SOURCES FOR THERMO-ELECTRIC COOLERS HAVE BEEN FOUND. FIVE NEW PUMP CONCEPTS HAVE BEEN CONFIGURED BY CSC.	525.0	262.0	164.0	DEC 80	DEC 80
5 80 1345	BIOLOGICAL MARKING SYSTEM THIS PROJECT WAS JUST FUNDED. NO STATUS REPORT IS REQUIRED.	463.0				
5 80 1348	SUPER TRIPICAL BLEACH THIS PROJECT WAS JUST FUNDED. NO STATUS REPORT IS REQUIRED.	202.0				
5 78 1353	SMOKE MIX PROCESS (GLATT) MANUFACTURED END ITEM WITH GLATT PYROTECHNIC MIXTURES FOR SAFETY TESTING AT NSL. BINDER STUDIES INITIATED.	390.6	15.0	105.0	OCT 80	OCT 80
5 79 1354	SLUDGE VOLUME REDUCTION AND DISPOSAL PROCESS STUDY COLLECTION AND EVALUATION OF MONITORING DATA PARAMETERS FOR WASTE TREATMENT EFFLUENT CONTINUED. ROTARY VACUUM FILTRATION PILOT EQUIP PREPARED FOR OPERATION. DESIGN OF SLUDGE Dewatering FACILITY PREPARED. CORE SAMPLES COLLECTED FROM FUTURE LANDFILL.	172.0		59.8	SEP 80	SEP 80
5 80 1354	SLUDGE VOLUME REDUCTION AND DISPOSAL PROCESS STUDY FUNDS JUST RECEIVED. NO STATUS REPORT IS REQUIRED.	256.0				
5 79 1355	MANUFACTURING PLANT TOXIC EFFLUENT/EMISSION PRETREATMENT IDENTIFIED TOXIC SUBSTANCES AT PBA. DEVELOPED AND APPLIED MONITORING METHOD TO DETERMINE TOXICITY OF PBA EFFLUENTS. CONDUCTED BATCH CARRUA TREATMENT OF PBA INDUSTRIAL WASTE. AWARDED CONTRACT TO BATTELLE LABS TO CONDUCT TESTING OF PBA EFFLUENTS.	104.0	51.7	52.3	JAN 81	SEP 80
5 80 1355	MANUFACTURING PLANTS TOXIC EFFLUENT/EMISSION PRETREATMENT FUNDS JUST RECEIVED. NO STATUS REPORT IS REQUIRED.	222.0				

SUMMARY PROJECT STATUS REPORT
 MANUFACTURING METHODS AND TECHNOLOGY PROGRAM
 2ND SEMI-ANNUAL SUBMISSION CY 79 RCS DRCHT-301

PROJ NO.	TITLE + STATUS	AUTHORIZED (\$000)	CONTRACT VALUES (\$000)	EXPENDED LABOR AND MATERIAL (\$000)	ORIGINAL PROJECTED COMPLETE DATE	PRESENT PROJECTED COMPLETE DATE
5 79 1403	IMPROVED PROC/SUBSTITUTION OF NONTOXIC DYES-M18 SMK GRENADES CHEMICALS, GRENADE HARDWARE AND FUZES WERE ORDERED AND RECEIVED. PYROTECHNIC MIXING, AND LOADING EQUIPMENT HAS BEEN LOCATED AND MOVED TO BLOC E3580.	315.0	21.0	21.0	JUN 81	JUN 81
5 80 1902	WFG METHODS OF GEL FUEL FOR FAE 80M88 BLU-95/B AND BLU-96/B THIS PROJECT WAS JUST FUNDED. NO STATUS REPORT IS REQUIRED.	305.0				
5 79 1903	DIE CAST TAILCONE + DESIGN MACHINE FOR BLU-96/B CONTRACT HAS BEEN AWARDED TO HONEYWELL. THE CONTRACT VALUE WAS NOT REPORTED. SUBCONTRACTS BETWEEN HONEYWELL AND DOELMER JARVIS AND KURT WFG ARE IN PROCESS.	450.0	20.0	20.0		
5 80 1903	DIE CAST TAILCONE + DESIGN MACHINE FOR BLU-96/B WORK NOT INITIATED.	1,176.0			MAR 81	MAR 81
5 79 1905	PBX CONTINUOUS CASTING FOR MUNITIONS LOADING WORK STATEMENTS WERE PREPARED FOR NAVY ORGANIZATIONS. WORK BEGUN IN PROCESS DELINEATION, EXPL CHARACTERIZATION, EQUIP SURVEY, EA, HAZARDS ANALYSIS, + INERT SIMULANT DEV. A SCOPE OF WORK FOR TECHNICAL SUPPORT TO BE PROVIDED BY CONTRACT WAS PREPARED.	250.0	30.1	30.1	DEC 80	DEC 80
5 76 3062	PELLET THERMAL POWER SUPPLY TECHNOLOGY GEL POWDERS ARE NOW BEING MADE IN-HOUSE WITH NEW EQUIPMENT. SEVERAL LOTS PREPARED USING VARIOUS PROCESSING TECHNIQUES. PROTOTYPE BATTERIES MADE WITH IN-HOUSE POWDERS ARE BEING MADE AND TESTED. FINAL REPORT STARTED.	150.0		150.0	JAN 78	MAR 80
5 77 3905	P8127 RESERVE POWER SUPPLY WFG FOR THE XMS87 FUZE TOOLING, ELECTRODE PUNCHING AND SEPARATORIES, ELECTRODE EDGE-PAINTING DEVICE, STACKING FIXTURE AND STACKING PART TOOLING WERE MADE AND OLV D TO EPL. SAMPLE BATTERIES MADE AND TESTED AT WOL WITH SATISFACTORY RESULTS.	375.0	300.0	50.0	NOV 78	FEB 80
5 78 3907	XMS80 COUNTER-MEMORY CIRCUIT FOR FUZES THE FIRST 3 PHASES HAVE BEEN COMPLETED. THE 4TH PHASE OF EVALUATING THE MANUFACTURING PROCESS AND RESULTS IS BEING PERFORMED.	300.0	273.6	15.0	SEP 79	FEB 80
5 79 3913	MECHANICAL JOINING OF MINIATURIZED ELECTRONIC COMPONENTS POL LASER WELDED DIAGRAMS TO LIQUID-FILLED BATTERY CUPS. WILL DEVELOP LASER PROCESS PARAMETERS INTO A DESIGN GUIDE. SHOULD WELD OTHER COMPONENTS, PCB'S, HYBRIDS, AND SEMICONDUCTORS.	89.0	45.6	6.0	DEC 79	MAY 80
5 77 3947	THICK FILM HYBRID CIRCUITS FOR XMS67E2/X-724 FUZES HONEYWELL BUILT 700 HYBRID OSCILLATORS AND DRAFTED A FINAL REPORT. BOTH WIRE BONDS AND TAPE BONDING WERE USED. RCA BUILT 800 HYBRID INTERFACE AND FIRING CIRCUITS. THEY WERE UNABLE TO BUILD 1200 CIRCUITS. P. TH FILM'S DRAFTED FINAL REPORTS.	150.0	120.0	30.0	SEP 79	JUN 80

SUMMARY PROJECT STATUS REPORT
 MANUFACTURING METHODS AND TECHNOLOGY PROGRAM
 2ND SEMIANNUAL SUBMISSION CY 79 RCS DRMT-301

PROJ NO.	TITLE + STATUS	AUTHORIZED (\$000)	CONTRACT VALUES (\$000)	EXPENDED LARGER AND MATERIAL (\$000)	ORIGINAL PROJECTED COMPLETE DATE	PRESENT PROJECTED COMPLETE DATE
5 78 3947	THICK FILM HYBRID CIRCUITS FOR M587E2/M724 FUZES SEE SUBTASKS A AND B. PRODUCTION PROBLEMS ILLUSTRATE DIFFICULTIES TRANSITIONING FROM R&D TO PRODUCTION.	556.0	529.7	28.0	JUL 79	JUN 80
5 78 3947 A	THICK FILM HYBRID CIRCUITS--MONEYWELL MONEYWELL DELIVERED ONLY 700 HYBRID OSCILLATOR CIRCUITS OF THE 2000 CONTRACTED FOR. MONEYWELL IS WORKING TO PERFECT THE TAPE AUTOMATED HANDLING SYSTEM. FINAL REPORT SHOULD BE READY IN EARLY 1980. THE COST OVERRUN WAS PARTIALLY FUNDED.	297.0	288.1	11.0	JUL 79	JUN 80
5 78 3947 B	THICK FILM HYBRID CIRCUITS--RCA RCA BURLINGTON SHIPPED ONLY 800 OF 2000 INTEGRATED ARMING AND FIRING CIRCUITS CONTRACTED FOR. THIS SHOWS THE PROBLEMS OF GOING FROM R&D TO VOLUME PRODUCTION. UNITS ARE TO BE GUN TESTED AT MDL.	263.0	241.6	11.0	JUL 79	JUN 80
5 79 3960	PROTOTYPE PCB EQUIP FOR PRINTED CIRCUIT BOARDS MDL IS INSTALLING COMMERCIAL CIRCUIT BOARD DRILLING, ETCHING, PLATING AND LASINATING EQUIPMENT FOR REALISTIC MANUFACTURE OF MULTIPLE BOARDS. WILL PROVIDE OR DISPROVE TECH DATA PACKAGES. PHOTOPLATTER IS STILL IN PROCUREMENT. SOLDER REFLOW UNIT RECEIVED.	405.0	205.0	35.0	DEC 79	SEP 80
5 79 3961	IMPROVED 3-IN VIBRATION ACCEPTANCE TEST FOR ART FUZES ONLY ONE CONTRACTOR RESPONDED TO THE RFP. THIS RESPONSE WAS NOT ACCEPTABLE. AFTER 2.5 MONTHS OF NEGOTIATIONS, AN ACCEPTABLE RESPONSE WAS PROVIDED. THE CONTRACT WAS AWARDED 31 DEC 1979. THE PROJECT SLIPPED DUE TO THE EXTENDED CONTRACT NEGOTIATIONS.	282.0	192.0	37.0	SEP 81	UCT 80
5 80 3961	I-PR (3-J) VIR ACCEPT TESTING F ART FUZES AND S/A MECHANISMS THIS PROJECT WAS JUST FUNDED. NO STATUS REPORT IS REQUIRED.	605.0				
5 77 4000	AUTOMATED M55 DETONATOR PRODUCTION EQUIPMENT MULTI-TOoled LHAUER HAZARD ANALYSIS PROGRAM AWARDED TO ALLEGANY BALLISTICS LAB (ABL). ABL VISITED IAAP FOR AN ACTUAL MACHINE REVIEW.	1,000.0	444.2	554.0	FFB 80	JUN 80
5 78 4000	AUTOMATED M55 DETONATOR PRODUCTION EQUIPMENT SONOBOND HAS ULTRASONIC WELDED 3K DETONATORS. CUP INSPECT MODULE HAS BEEN REQUESTED SUCCESSFULLY. DETAILED DESIGN REVIEW OF CRITICAL INSPECT MODULE OBTAINED APPROPRIATE APPROVAL. 4500 DETONATORS WERE LACQUERED AT LSAAP FOR COMPANISON TESTS.	1,250.0	693.9	404.1	DEC 79	JUN 80
5 79 4000	AUTOMATED M55 DETONATOR PRODUCTION EQUIPMENT ASSEMBLY OAG HAS BEEN COMPLETED FOR A CONTINUOUS PALLET INDEXER TO FEED THE INSPECTOR MODULE. SPECS FOR PROGRAMMABLE CONTROLLER IS NEAR COMPLETION. TEST CONDUCTED ON CHAMLEE + BALL LOADER. PA-130 TASK HAS BEEN REPLACED BY TASK TO LOOK AT OTHER MIXES	1,600.0	365.0	422.7	MAR 81	MAR 81

MANUFACTURING METHODS AND TECHNOLOGY PROGRAM
 S U M M A R Y P R O J E C T S T A T U S R E P O R T
 2ND SEMI-ANNUAL SUBMISSION CY 79 RCS DRCHT-301

PROJ NO.	TITLE + STATUS	AUTOMATIZED (\$000)	CONTRACT VALUES (\$000)	EXPENDED LABOR AND MATERIAL (\$000)	ORIGINAL PROJECTED COMPLETE DATE	PRESENT PROJECTED COMPLETE DATE
5 80 4000	AUTOMATED #55 DETONATOR PRODUCTION EQUIPMENT FUNDS RECEIVED 16 NOV 79. NO WORK ACCOMPLISHED.	475.0	131.0		MAR 81	MAR 81
5 74 4009	AUTO OF EQUIP FOR A/P OF SMALL SHAPED CHARGE ROCKETS NO ACTION TAKEN DURING REPORTING PERIOD.	1,040.7	825.1	215.6	MAY 75	DEC 80
5 76 4009	AUTO OF EQUIP FOR A/P OF SMALL SHAPED CHARGE ROCKETS NO ACTION TAKEN DURING PERIOD.	780.0	519.5	216.3	MAR 77	DEC 80
5 75 4012	FINAL ROLL MILL/PAID-MAKEUP MACHINE FOR MORTAR INCREMENTS THE AS BUILT FINAL ROLL AND PAID MAKE-UP LINE FOR MORTAR SHEET PROPELLANT WAS CHECKED OUT WITH INERT COMPOSITION. ALL MAJOR TOOLING MODIFICATIONS TO THE FOUR-ROLL CALENDER WERE COMPLETED.	700.0	606.3	89.6	JUN 76	JUN 80
5 79 4024	DSN OF V HLD PROT COMP AND AUTO ASSY MACH M223 FZ A CONTRACT WAS AWARDED TO INNOVA INC. THE CONTRACTOR WILL DESIGN, FABRICATE, AND TEST A PROTOTYPE AUTOMATED ASSEMBLY SYSTEM CAPABLE OF PRODUCING 90 PER MINUTE, ACCEPTABLE FUSES.	1,132.0	945.1	27.0	SEP 81	SEP 81
5 80 4027	COMBINED SOLVENT RECOVERY/DRYING OF S-B PROPELLANT THIS PROJECT WAS JUST FUNDED. NO STATUS REPORT IS REQUIRED.	307.0				
5 80 4033	CAUSTIC RECOVERY FROM SODIUM NITRATE SLUDGE THIS PROJECT WAS JUST FUNDED. NO STATUS REPORT IS REQUIRED.	153.0				
5 80 4037	PROCESS IMPROVEMENT FOR PLASTIC-BONDED EXPLOSIVES THIS PROJECT WAS JUST FUNDED. NO STATUS REPORT IS REQUIRED.	236.0				
5 78 4041	AUTO EQUIP FOR ASSY OF MORTAR COMPONENTS FABRICATION + ASSEMBLY OF LINE HAS BEEN COMPLETED. PRELIMINARY DEBUG WAS NEAR COMPLETION WHEN OPERATIONAL PROBLEMS WERE ENCOUNTERED. ADDITIONAL FUNDS WERE APPROVED TO RESOLVE PROBLEMS. UPON RECEIPT OF FUNDS, REDESIGN, DEBUG + TEST WILL BE DONE.	759.0	566.1	140.7	JUL 79	JUL 80
5 79 4046	QUANTITATIVE ANAL. OF BLENDED EXPLOS. SAMPLES UPDATED PRIORITIZED LISTING OF EXPLOSIVES TO BE ANALYZED PREPARED. DRAFT TR OF RAPID CHEM ANAL OF NOL-130 PRIMER MIX USED FOR TRNG. SCOPE OF WORK AMENDED TO INCL A QUALITATIVE UPERG AND SUPPORT HAZARDS ANAL OF RAPID CHEM ANALYSIS EQUIPMENT.	307.0	70.0	39.8	NOV 80	NOV 80
5 75 4050	AUTOMATED LOADING OF PROPELLANT FLASH MEDICERS. APPROX. \$100K REQUESTED ADDITIONAL FUNDING TO DEBUG AND TEST LEADERS.	1,067.4	847.9	218.2	MAR 76	JUN 80
5 79 4051	IMPROVED MASTER CONTROL FOR ACID PLANTS A DRAFT OF A FINAL REPORT HAS BEEN PREPARED CONTAINING RECOMMENDED INSTRUMENTATION TO REPLACE DEFICIENT INSTRUMENTS, COSTS TO REPLACE CHARTS FOR IND METHODS OF PROCESS ANALYSIS, AND LIST OF CONTROL INSTR WHICH ARE OBSOLETE AT GOCF ACID PLANTS.	157.0		135.6	DEC 79	DEC 79

MANUFACTURING METHODS AND TECHNOLOGY PROGRAM
 SUBMITTAL REPORT STAFF REPORT
 TWO SEMIANNUAL SUBMISSION CY 79 MCS DRCMT-301

PROJECT NO. TITLE + STATUS

PROJECT NO.	TITLE + STATUS	AUTHORIZED (\$000)	CONTRACT VALUES (\$000)	EXPENDED LABOR AND MATERIAL (\$000)	CRITICAL PROJECT COMPLETE DATE	PRESIDENT PROJECT COMPLETE DATE
5 74 4054	PROC IMPROVED ENG F/PROCAST OF ARTY PROP CHARGE MFR CLOTH AND PRINT INSPECTION PROTOTYPE MACHINE HAS BEEN SHIPPED TO INDIA. AAP. CONTRACTUAL ACTION IS BEING TAKEN TO SHIP THE 3-D BAG MANUFACTURING PROTOTYPE MACHINE TO ANRADCOM. IT IS EXPECTED THAT THE MACHINE WILL BE SHIPPED DURING JAN. 80.	700.1	412.6	270.1	MAR 75	JAN 75
5 79 4059	OPTIMIZATION - NITROGUANADINE IN M30 PROPELLANT TAD MICROTRAC PARTICLE SIZE ANALYZERS WERE ORDERED. ONE WILL BE USED FOR THE CRYSTALLIZED SLURRY, THE OTHER FOR THE FINAL PRODUCT AS IT LEAVES THE DRYER. THE EQUIPMENT HAS ARRIVED AT SFAAP. A HAZ ANAL IS BEING CONDUCTED BY ABL.	250.0	225.0	7.3	APR 81	JAN 81
5 80 4061	NITROGUANADINE PROCESS OPTIMIZATION THIS PROJECT WAS JUST FUNDED. NO STATUS REPORT IS REQUIRED.	260.0				
5 79 4062	AUTO MFG SYSTEM FOR MORTAR INCREMENT CONTAINERS PROJECT IS CURRENTLY IN HOLD STATUS AWAITING OUTCOME OF 1ST ARTICLE TESTING AND GUIDANCE FROM PW/PH. A MINIMAL EFFORT IS CONTINUING AND PROJECT CAN MOVE FORWARD IMMEDIATELY IF PROBLEMS ARE RESOLVED. MILESTONES WILL BE REVISED WHEN PROJECT RESTARTED.	507.0	11.0	82.1	APR 82	AUG 82
5 80 4062	AUTO MANUFACTURE SYS F/MORTAR INCREMENT CONTAINERS THIS PROJECT WAS JUST FUNDED. NO STATUS REPORT IS REQUIRED.	895.0				
5 79 4064	AUTO CAP OPERATIONS FOR 105MM TANK CARTRIDGES A CONTRACT FOR THE DEVELOPMENT STUDY + THE DESIGN PROGRAM WAS AWARDED RSI INDUSTRIES. THEY WERE PROVIDED TECH DATA ON CURRENT METHODS + EQUIPMENT USED AT MAAP.	1,262.0	919.7	80.8	SEP 80	SEP 80
5 80 4071	EXPLOSIVE DUST HAZARDS IN MULTIPLE PLANTS THIS PROJECT WAS JUST FUNDED. NO STATUS REPORT IS REQUIRED.	252.0				
5 79 4084	OPACITY/MASS EMISSION CORRELATION STACK MODIFICATIONS WERE MADE ON THE ERIE FORGE AT SCRANTON AAP. JACA CORP HAS COMPLETED SITE SURVEY AND SAMPLE COLLECTION.	121.0	92.5	12.8	JUN 81	JUN 81
5 80 4084	OPACITY/MASS EMISSION CORRELATION THIS PROJECT WAS JUST FUNDED. NO STATUS REPORT IS REQUIRED.	111.0				
5 80 4086	REPROCESSING EXPLOSIVE FINES AND DRILL SCRAP THIS PROJECT WAS JUST FUNDED. NO STATUS REPORT IS REQUIRED.	357.0				
5 77 4105	AUTO INCREMENT L/A OF PROP CHARGE + CENTRAL CORE IGNITERS INSTALLATION OF PHASE 3 LOADING AND ASSEMBLY MODULES WAS COMPLETED AT CHARGE. EQUIPMENT WAS NOT ACCEPTED BECAUSE OF DEFICIENCIES IN WELDS, BARRIERS AND STEEL ROLLER CHAINS.	1,384.9	1,053.2	331.7	MAY 78	SEP 80

SUMMARY REPORT
 MANUFACTURING METHODS AND TECHNOLOGY PROGRAM
 STAFF REPORT
 2ND SEMIANNUAL SUBMISSION CY 79 RES DRCMT-301

PROJ NO.	TITLE + STATUS	AUTHORIZED RIZED (\$000)	CONTRACT VALUES (\$000)	EXPENDED LARGE AND MATERIAL (\$000)	ORIGINAL PROJECTED COMPLETE DATE	PRESENT PROJECTED COMPLETE DATE
5 77 4114	POLLUTION ABATEMENT METHODS FOR P+E SEE PROJECT 5 77 4114.	500.0		225.0	SEP 78	MAY 80
5 75 4114	METHODS TO MINIMIZE ENVIRONMENTAL CONTAMINATION SEE PROJECT 5 77 4114.	5,947.1	2,007.2	1,400.5	MAY 78	MAY 80
5 76 4114	METHODS TO MINIMIZE ENVIRONMENTAL CONTAMINATION SEE PROJECT 5 77 4114.	5,200.0	1,429.5	1,575.5		APR 80
5 77 4114	DEVELOPMENT OF POLLUTION ABATEMENT TECHNOLOGY SEE FOLLOWING INDIVIDUAL TASKS FOR WORK STATUS.	1,007.0	100.4	597.0	NOV 79	JUN 80
5 77 4114 P01	IDENT + CONTROL OF POLLUTION - PRESENT REQTS STUDIES WERE CONDUCTED ON DISCHARGES TO THE SCRANTON MUNICIPAL SEWER. A COMPREHENSIVE WASTE WATER INVENTORY FOR MISS AAP WAS PREPARED.	59.0		59.0	SEP 77	FEB 79
5 77 4114 P01	PROGRAM CONTROL, COMBINATION AND SUPPORT A FINAL REPORT TITLED EMISSIONS VS CAPACITIES HAS BEEN FORWARDED FOR PUBLICATION.	176.5	26.9	149.6	SEP 78	SEP 79
5 77 4114 P04	NOX ABATEMENT METHODS FINAL TECH REPORT FOR THE MOLECULAR SIEVE EVALUATION PROJECT AT AAP HAS REVISED.				NOV 79	NOV 79
5 77 4114 P06	PROPELLANT AND EXPLOSIVE WASTE INCINERATION VERTICAL INCINERATOR WAS CONVERTED TO A FLUIDIZED BED INCINERATOR. EFFECTIVENESS OF ROTARY KILN INCINERATOR WAS TESTED.				JUN 77	JUN 79
5 77 4114 P08	DISPOSAL OF RED WATER FROM TMT PURIFICATION FINAL REPORT ON SOURCE ASSESSMENT OF EMISSIONS FROM MULTI-HEARTH FURNACE TESTS WAS RECEIVED FROM APMA.				JUN 77	JUN 79
5 77 4114 P10	DISPOSAL OF WASTES FROM PROPPELLANT MFG SAMPLES OF WASTES FROM THE PLANT WERE RUN THROUGH THE PLATE AND FRAME EXTRACTION UNIT TO REMOVE AND RECOVER THE SPENT GLASSES.				MAR 79	APR 80
5 77 4114 P12	ELIMINATION OF ORGANIC WASTES SUCH AS SOLVENT DRYING TESTS OF MULTIPHASE PREPARATIONS WERE COMPLETED. TWO PRELIMINARY TESTS FOR SOLVENT DISPOSAL WERE OUTLINED.				AUG 77	SEP 79
5 77 4114 P16	PROCESS WATER WASTEWATER TREATMENT FINAL REPORT FOR THE MISS AAP WAS WHEN APPROPRIATE.	377.0	62.0	282.4	NOV 77	AUG 79

S U M M A R Y P R O J E C T S T A T U S R E P O R T
 2ND SEMI-ANNUAL SUBMISSION, CY 79 RCS DRCHT-301

MANUFACTURING METHODS AND TECHNOLOGY PROGRAM

PROJ NO.	TITLE + STATUS	AUTOMATIZED (\$000)	CONTRACT VALUES (\$000)	EXPENDED		PRESENT PROJECTED COMPLETE DATE
				LABOR AND MATERIAL (\$000)	ORIGINAL PROJECTED COMPLETE DATE	
5 77 4114 P19	METHODS + EGPT TO MONITOR AND CONTROL POLLUTANTS EVALUATION OF THE NO MONITOR AND CONTROL SYSTEM HAS BEEN COMPLETED. THE CARBON AND SULFIDE MONITORS ARE OPERATIONAL. THE VAPOR MONITOR IS BEING MODIFIED.	377.0	62.0	282.4	JAN 79	MAR 80
5 77 4114 P27	SOLID WASTE SOIL DISPOSAL TECHNIQUES SMALL AMOUNTS OF COMPOSTED TYP RESIDUE HAVE BEEN PREPARED FOR TOXICITY STUDIES.				MAR 78	APR 81
5 77 4114 P34	OXIDATION OF NITROBODIES FINAL REPORT RECEIVED CONCERNING THE TREATMENT OF PINK WATER UTILIZING WHITE OIL SOLVENT EXTRACTION.	176.5	11.5	165.0	MAY 78	NOV 79
5 76 4122	PRODUCTION LINE MODERNIZATION FOR CRU REAPONS TECHNICAL DATA PACKAGE REQUESTS FOR CRU 25, 46, 52, 58, 71, AND 75 HAVE BEEN WRITTEN. INCORPORATING APPROXIMATELY 90 PERCENT OF ALL REVIEW COMMENTS TO DATE. CERTAIN TOP VOLUMES WILL BE RESUBMITTED FOR BASELINING AFTER ALL MODIFICATIONS.	721.0	128.0	574.3	MAR 77	APR 80
5 79 4124	FABRICATION OF CONTROL ACTIVATION SYSTEM HOUSINGS CHANDLER-PALMS AND ITS MAJOR SUBCONTRACTOR ARE DEVELOPING DATA FOR A MASTER PLAN REVIEW. THIS PROJECT HAS ALREADY SLIPPED 5 MONTHS DUE TO CONTRACT AWARD DELAYS. ADDITIONAL SLIPPAGE IS ALMOST CERTAIN DUE TO THE OPTIMISTIC SCHEDULING.	930.0	786.2	14.0	JUN 80	DEC 80
5 80 4131	SHELL MOLOGRAPHIC INSPECTION AND EXAMINATION LINE DEVICE THIS PROJECT WAS JUST FUNDED. NO STATUS REPORT IS REQUIRED.	556.0				
5 75 4136	DEVELOPMENT OF A GENERALIZED MATH MODEL CANNOT DETERMIN THE STATUS OF THIS PARTICULAR FY OF EFFORT. SEE PROJECT 5 7A 4136.	180.0		180.0	JAN 74	JUL 79
5 76 4136	DEVELOPMENT OF A GENERALIZED MATH MODEL MODEL DEVELOPMENT IS CONTINUING. FORMULAS FOR COMPUTATION OF LINE AVAILABILITY IN TERMS OF STATION AVAILABILITY WERE DERIVED FOR SEVERAL HYPOTHESIZED MODELS. A FINAL REPORT WAS RECEIVED BY ARRABCO ON 30 NOV 79.	150.0	21.5	128.5	JUN 77	DEC 79
5 79 4137	AUTOMATED LOADING OF CENTER CORE IGNITERS A FEASIBILITY STUDY AT INDIANA AAP HAS BEEN ADDED TO THE PROJECT. FIVE BASIC CONCEPTS FOR AUTOMATED LOADING HAVE BEEN IDENTIFIED AT ARRABCO AND THAT BE THESE WILL BE SELECTED FOR INTENSIVE STUDY.	205.0	91.0	47.7	OCT 79	APR 80
5 80 4137	AUTOMATED LOADING OF CENTER CORE IGNITERS THIS PROJECT WAS JUST FUNDED. NO STATUS REPORT IS REQUIRED.	967.0				

MANUFACTURING METHODS AND TECHNOLOGY PROGRAM
 S U M M A R Y P R O J E C T S T A T U S R E P O R T
 2ND SEMIANNUAL SUBMISSION CY 79 RCS DRMT-301

PROJ NO.	TITLE + STATUS	AUTOM- RIZED (\$000)	CONTRACT VALUES (\$000)	EXPENDED LABOR AND MATERIAL (\$000)	ORIGINAL PROJECTED COMPLETE DATE	PRESENT PROJECTED COMPLETE DATE
5 79 4139	APPL OF RADAR TO BALLIST ACC TESTG OF AMMO-ARBAT. THIS FY OF FUNDING WAS TO CONTINUE TESTING AND CORRECT DEFICIENCIES. ARRADCUM HAS DISCONTINUED SUPPORT OF THIS SYSTEM AND TURNED IT OVER TO TECOM FOR FINAL DEBUGGING AND INSTALLATION.	265.0	236.8	16.0	SEP 79	JAN 80
5 78 4143	WFG OF CASTERS AND COMP F/M259 + M264 ROCKETS AN INTERIM RPT WAS SUBMITTED AND APPROVED FOR PHASE I CONTRACTOR EFFORTS. THIS REPORT INCLUDED A COST BREAKDOWN FOR EACH CANDIDATE MANUFACTURING PROCESS. THE SOM WAS CHANGED TO REQUIRE THE INCORPORATION OF THE BEST QUALITIES OF 3 DESIGNS INTO 1 DESIGN	160.0	82.2	48.5	MAR 80	JUN 80
5 74 4147	COMPUTER CONTROL APPLICATION TO CONTINUOUS TNT MANUFACTURE INSTALLATION OF THE ANALOG FIELD EQUIPMENT WAS NEARING COMPLETION. THE CONTROL ROOM EQUIPMENT WAS LOCATED IN THE GUNLINE ELECTRICAL INTERCONNECTION BETWEEN THE RACKS WAS COMPLETED BUT CONNECTION OF FIELD SIGNALS TO THE CONTROL ROOM ELECTRONICS HAS NOT.	901.0	655.0	30.0	NOV 75	NOV 80
5 78 4149	LOADING OF 30MM ADEN/DEFA HEDP AMMUNITION AN IN-HOUSE MALFUNCTION IN THE R&D PROGRAM HAS PUT THIS PROJ IN A HOLD STATUS EXCEPT FOR COMPLETING EXISTING INVESTIGATIONS WHICH ARE MINIMAL. ALL PHASES OF THIS PROGRAM WILL BE ADJUSTED BASED ON W&D FINDINGS.	500.0	405.7	68.4	MAY 79	APR 80
5 78 4150	NEW MANUFACTURING PROCESSES FOR SAMS AMMUNITION A CONTRACT FOR ROLL FORMING WAS LET TO KINEFAC CORP. THE CATEGORY PARREL CONTRACT FOR COLD HEADING IS IN PROCESS. A NEW SCHEDULE WITH AT LEAST 2 MONTHS SLIPPAGE IS INDICATED.	61.4	21.4	26.5	SEP 80	JUN 81
5 79 4150	NEW MANUFACTURING PROCESSES FOR SMALL CALIBER PENETRATORS A SCOPE OF WORK HAS PREPARED, APPROVED AND FORWARDED TO PROCUREMENT. THIS IS NOT A COMPLETE PROJECT. THERE IS NO INDICATION OF HOW THE EFFORT WILL BE IMPLEMENTED EVEN IF IT IS SUCCESSFUL.	376.0	220.0	40.0	MAR 81	MAR 81
5 80 4152	NEW MANUFACTURING PROCESSES FOR SAMS AMMUNITION THIS PROJECT HAS JUST FUNDED. NO STATUS REPORT IS REQUIRED.	489.0				
5 78 4153	INERTIA HEADER FOR THE M509 AND M483 PROJECTILES ASKED CONTRACTORS TO VERIFYING ULTRASONIC SCAN INSPECTION ON INERTIA HEADED BARRIS.	350.0	225.0	10.0	AUG 80	AUG 80
5 79 4163	CONTROLLED PRODUCE LEADING SYS F/105MM HEAT-T M456A1 SWP CHANGES TO INCLUDE DESIGN OF PHOTOTYPE SYSTEM TO LOAD M456A1 AT MILAN. 32 TEST PLANS WERE MADE. A SUCCESSFUL PROCESS FOR LEADING THE M456 PROJECT WAS ESTABLISHED.	390.7	320.2	320.2	DEC 79	JAN 80

S U M M A R Y P H O J E C T S T A T U S R E P O R T
2ND SEMI-ANNUAL SUBMISSION CY 79 RCS DRGMT-301

MANUFACTURING METHODS AND TECHNOLOGY PROGRAM

PROJ NO.	TITLE + STATUS	AUTHORIZED (\$000)	CONTRACT VALUES (\$000)	EXPENDED LABOR AND MATERIAL (\$000)	ORIGINAL PROJECTED COMPLETE DATE	PROJECTED COMPLETE DATE
5 80 4182	PROCESS IMPROVEMENTS AND AUTO TEST FOR WAAK, GEMSS, GATOR THIS PROJECT WAS JUST FUNDED. NO STATUS REPORT IS REQUIRED.	200.0				
5 79 4189	HIGH FRAGMENTATION STEEL PRODUCTION PROCESS A CONTRACT WAS LET TO SCRANTON, SCRANTON HAS ISSUED PURCHASE ORDERS TO BETHLEHEM STEEL AND REPUBLIC STEEL FOR ONE HEAT EACH OF #61.	533.0	377.0	105.8	JUN 80	JUN 80
5 80 4189	HIGH FRAGMENTATION STEEL PRODUCTION PROCESS SCOPE OF WORK HAS BEEN PREPARED AND SENT TO ARCCUM FOR AWARD.	848.0			JAN 81	JAN 81
5 79 4194	IMPROVED PROCESS F/PRESSING LX-14 EXPL CHARGES TEST EQUIPMENT AND MATERIALS WERE ORDERED AND SOME RECEIVED. DESIGN AND DRAWINGS WERE PREPARED FOR MODIFIED PRESSING TOOLS. PRESSES AND BUILDINGS TO BE USED AT ARHADCOM FOR THIS OPERATION ARE BEING REPAIRED.	327.0	16.0	34.4	JAN 81	JAN 81
5 80 4200	7.7 CRYSTALLIZER FOR LARGE CALIBER MUNITIONS THIS PROJECT WAS JUST FUNDED. NO STATUS REPORT IS REQUIRED.	304.0				
5 77 4202	PRUDED F/CONT AUTO PROD OF SOLVENT- TYPE MULTI-BASE PROP THE FINAL REPORT HAS BEEN FORWARDED TO ARHADCOM FOR EDITING.	505.0	307.8	176.3	MAR 78	APR 80
5 80 4210	DRY CUTTING OF ENERGETIC MATERIALS THIS PROJECT WAS JUST FUNDED. NO STATUS REPORT IS REQUIRED.	497.0				
5 77 4211	MOD OF PROCESS CONTROL OF EXPLOSIVE COMPOSITIONS EVALUATION OF ROXTRIT COMPOSITION ANALYZER IS COMPLETE. CONTRACT FOR DEVELOPMENT OF AUTO IMPACT TESTER WILL NOT BE IMPLEMENTED. WORK WILL BE DONE IN HOUSE. DEVICE TO TEST FOR IMPACT SENSITIVITY IS UNDER CONSTRUCTION	427.0	124.3	189.8	AUG 78	DEC 80
5 78 4214	POLLUTION ENGINEERING FOR 1983-85 REQUIREMENTS SEE FOLLOWING INDIVIDUAL TASKS FOR WORK STATUS.	1,180.0	516.2	633.4	SEP 79	SEP 80
5 78 4214 P1	TECHNOLOGY REQUIREMENTS RELATED WOD AND MCA PROGRAMS HAVE BEEN REVIEWED, A SOM FOR CHEMICAL ASSESSMENT HAS BEEN IMPLEMENTED.	211.7		184.4	SEP 79	SEP 80
5 78 4214 P2	IMPLANT RELSE OF POLLUTION ABATED WATERS PHASE 1 AND PHASE 2 OF THE CSL REVISED AMMONIA RECOVERY PROCESS HAVE BEEN COMPLETED. FEASIBILITY OF REUSING EFFLUENT FROM THE SAR TREATMENT FACILITY WAS STUDIED.	377.0	150.3	245.4	JUL 79	SEP 80
5 78 4214 P3	LOW COST SYSTEM TO ABATE NITROGEN POLLUTION A PILOT SCALE CONTINUOUS FLOW EXTRACTOR HAS BEEN ASSEMBLED AT IOWA AAP. CONTRACT AWARDED TO HAZARDS RESEARCH CORP TO EVALUATE USE OF SUPPLACANT TECHNOLOGY FOR REMOVAL OF TNT AND RDX.	355.0	235.9	118.9	JUL 79	SEP 80

S U M M A R Y P H O J E C T S T A T U S R E P O R T
 2ND SEMI ANNUAL SUBMISSION CY 79 RCS DRCHT-301

PROJ NO.	TITLE + STATUS	AUTHORIZED (\$000)	CONTRACT VALUES (\$000)	EXPENDED LABOUR AND MATERIAL (\$000)	ORIGINAL PROJECTED COMPLETE DATE	PRESENT PROJECTED COMPLETE DATE
5 78 4214 P4	NG-NITRATE ESTER REMOVAL BY ADSORPTION/RECYCLE BENCH SCALE ADSORPTION TESTS WERE RESUMED AFTER COMPLETION OF A SAFETY FIELD REVIEW AND APPROVAL OF UNIT OPERATING PROCEDURE.	236.0	150.0	84.8	JUL 78	JUL 80
5 79 4214	POLLUTION ENGINEERING FOR 1983-85 REQUIREMENTS SEE FOLLOWING INDIVIDUAL TASKS FOR WORK STATUS.	1,269.0	553.0	381.4	SEP 80	NOV 80
5 79 4214 P1	TECHNOLOGY REQUIREMENTS BENCH SCALE STUDIES OF ACETONE/ETHANOL SOLVENTS HAVE BEEN INITIATED.	367.0	142.0	71.2	SEP 79	NOV 80
5 79 4214 P2	IN-PLANT REUSE OF POLLUTION ABATED WATERS STUDIES WERE INITIATED TO DETERMINE PROCESS WATER REQUIREMENTS.	449.0	296.0	153.0	JUL 80	NOV 80
5 79 4214 P3	LOW COST SYSTEM TO ABATE NITROBODY POLLUTION EVALUATION OF UV-OZONE UNIT AT TUNA AWP WAS CONTINUED. AN UV-OZONE UNIT WAS LEASED BY KANSAS AAP.	325.0	45.0	123.8	MAR 80	AUG 80
5 79 4214 P4	NG-NITRATE ESTER REMOVAL BY ADSORPTION/RECYCLE WASTEWATERS CONTAINING NG AND ONG WERE PASSED THROUGH AN ADSORPTION COLUMN CONTAINING XAD-4 RESIN.	128.0	70.0	33.4	SEP 80	SEP 80
5 74 4215	AUTO THE CONTINUOUS INT PROD FACILITY PROCESS CONTROLS THE EVALUATION OF THE LIQUID CHROMATOGRAPH SYSTEM HAS BEEN COMPLETED. A ROUGH DRAFT FINAL REPORT HAS BEEN PREPARED.	323.8	224.8	99.2	MAY 75	MAR 80
5 77 4223	APPLICATION OF ULTRASONIC ENERGY TO DOUBLE-PHASE PROP PROC THE FACILITY MAINTENANCE PROGRAM TO CORRECT BREAKDOWNS IN THE EXTRUDER SYSTEM WAS COMPLETED. HOT SPOT ON SLEEVE PIECE WAS CORRECTED.	363.0	59.0	266.9	SEP 78	JUN 80
5 79 4225	RED WATER POLLUTION ABATEMENT SYSTEM MASS BALANCE ANALYSES WERE MADE ON THE MULTI-HEARTH PILOT FURNACE AT RAAP. RED WATER FROM VAPOR WAS SUCCESSFULLY CONCENTRATED AT CHETRON USING A ROTATOR-TURBA-FILM EVAPORATOR. ADDITIONAL PROCESS DATA OBTAINED ON SONGOO SULFITE RECOVERY PROCESS.	350.0	230.0	23.6	OCT 80	OCT 80
5 80 4225	RED WATER POLLUTION ABATEMENT SYSTEM THIS PROJECT WAS JUST FUNDED. NO STATUS REPORT IS REQUIRED.	155.0				
5 80 4226	ON-LINE MONITORS FOR WATER POLLUTANTS THIS PROJECT WAS JUST FUNDED. NO STATUS REPORT IS REQUIRED.	405.0				
5 78 4228	AUTOMATED BAG LADING/CHARGE ASSEMBLY + PACKOUT-155MM/BIN FINAL REPORT HAS BEEN SUBMITTED. TOP FOR THE PACKOUT WAS COMPLETED.	137.4		136.6	AUG 78	FEB 80

MANUFACTURING METHODS AND TECHNOLOGY PROGRAM
 S U M M A R Y P R O J E C T S T A T U S R E P O R T
 2ND SEMIANNUAL SUBMISSION CY 79 RCS DRCMT-301

PROJ NO.	TITLE + STATUS	AUTHORIZED (\$000)	CONTRACT VALUES (\$000)	EXPENDED LABOR AND MATERIAL (\$000)	ORIGINAL PROJECTED COMPLETE DATE	PRESENT PROJECTED COMPLETE DATE
5 80 4231	IN-PLANT REUSE OF POLLUTION ABATED WATERS THIS PROJECT WAS JUST FUNDED. NO STATUS REPORT IS REQUIRED.	558.0				
5 80 4236	AUTO LACE JACKETS FOR CENTER CORE CHARGES THIS PROJECT WAS JUST FUNDED. NO STATUS REPORT IS REQUIRED.	612.0				
5 78 4237	CONTINUOUS TNT PROCESS ENGINEERING *WORK HAS BEEN AT A STANDSTILL SINCE \$170K WAS WITHDRAWN FROM FY78 FUNDS IN JAN 79. ONLY THE FINAL REPORT HAS TO BE PREPARED. THE CONTRACTOR IS DELAYING HIS SUBMISSION OF A FINAL REPORT BECAUSE OF SOME UNFINISHED WORK IN THE RDX PILOT PLANT.	130.0	9.0	121.0	FEB 79	MAY 80
5 78 4249	SEPARATION OF EXPLOSIVES FROM SPENT ACID/WATER SLURRIES ADDITIONAL FUNDS FOR COMPLETING INSTALLATION AND EVALUATION OF BIRD PANNEVIS FILTER HAS NOT BEEN RECEIVED. NAVY HAS INDICATED NO OBJECTIONS TO THE USE OF BIRD PANNEVIS FILTER FOR MFR OF HMX.	250.0	220.0	24.7	DEC 78	APR 81
5 77 4252	IMPROVE PRESENT PROCESSES FOR THE MANUFACTURE OF RDX + HMX FINAL REPORT NO. HOC-47-78 WAS PUBLISHED ON *DRX ACCOMPLISHED. INERT CHECKOUT AND BATCH SIMULATED RUN OF RDX HMX PILOT PLANT AT ARRADCOM WAS COMPLETED. YIELDS AND PURITY OF HMX PRODUCED WERE COMPARABLE TO THAT PRODUCED AT HOLSTON AAP.	864.2	653.1	231.1	DEC 77	JAN 80
5 78 4252	IMPROVE PRESENT PROCESSES FOR THE MANUFACTURE OF RDX + HMX BENCH SCALE STUDIES ON THE HMX SIMMER PROCESS WERE COMPLETED TO OBTAIN BASELINE DATA. STUDIES INCLUDED EFFECTS OF TIME, TEMPERATURE AND CONCENTRATION OF NITRIC AND ACETIC ACID. STATISTICAL ANALYSIS IN PROCESS ON COMBINED EFFECTS.	281.0	57.0	68.4	MAY 80	APR 80
5 80 4253	AUTO HIGH-RATE UNPACK EQUIP FOR MORTAR PROP CMGS THIS PROJECT WAS JUST FUNDED. NO STATUS REPORT IS REQUIRED.	502.0				
5 76 4263	AUTO PILOT LINE FOR CONTROLLED COOL/PROCESSING HE LOAD PROJ PROJECT EFFORT COMPLETE. FINAL STATUS REPORT WILL BE SUBMITTED BY 30 JUN 80.	1,144.9	778.6	365.8	JUN 77	JUN 80
5 77 4263	AUTO PILOT LINE FOR CONTROLLED COOL/PROCESSING HE LOAD PROJ PROJECT EFFORT COMPLETE. FINAL STATUS REPORT WILL BE SUBMITTED BY 30 JUN 80.	900.0	153.4	739.9	SEP 78	JUN 80
5 78 4263	AUTO PILOT LINE FOR CONTROLLED COOL/PROCESSING HE LOAD PROJ PROJECT EFFORT COMPLETE. A FINAL STATUS REPORT WILL BE SUBMITTED BY 30 JUN 80.	257.0	56.4	200.6	OCT 78	JUN 80
5 79 4263	AUTO PILOT LINE FACULT COOL AND PROC OF HE LO PROJ EXPLOSIVE LOADING OPERATIONS WERE INITIATED AT EXPANDED MELT-LOAD PILOT PLANT. INITIAL LOADING STUDIES ARE BEING CONDUCTED USING COMP B GRADED 455-1107.	329.0	25.0	133.7	JUL 80	JUL 80

SUMMARY PROJECT STATUS REPORT
 2ND SEMIANNUAL SUBMISSION CY 79 RCS DRGMT-301

PROJ NO.	TITLE + STATUS	AUTHORIZED (\$000)	CONTRACT VALUES (\$000)	EXPENDED LABOR AND MATERIAL (\$000)	ORIGINAL PROJECTED COMPLETE DATE	PRESENT PROJECTED COMPLETE DATE
5 80 4266	MFG, INSP AND TEST EQUIPMENT FOR MAGNETIC POWER SUPPLY THIS PROJECT WAS JUST FUNDED, NO STATUS REPORT IS REQUIRED.	345.0				
5 77 4267	CONTINUOUS PROCESS FOR GRANULAR COMPOSITION B LOVE STAR MAP WAS SELECTED AS SITE FOR GRANULAR COMP B PILOT PLANT FACILITY. SITE PLAN FOR PRILLING TOWER COMPLETED. SCOPE OF WORK REVISED TO INCLUDE DESIGN EFFORT AND INITIAL PROCUREMENT OF EQUIPMENT.	500.0	429.3	70.7	SEP 79	JUN 80
5 78 4267	CONTINUOUS PROCESS FOR GRANULAR COMPOSITION B SCOPE OF WORK PREPARED TO COMPLETE ALL WORK AND TOTAL INSTALLATION. DECISION MADE TO USE SEMI-REMOTE BATCH OPERATION WITH PUMPING. SYSTEM WILL BE PURGED AT CONCLUSION OF EACH RUN.	56.0	9.0	42.7	MAR 81	JFC 81
5 80 4274	RECOV + REGEN OF PROPL MFG SOLVENTS BY AUTO CONTROL THIS PROJECT WAS JUST FUNDED, NO STATUS REPORT IS REQUIRED.	253.0				
5 77 4281	ENERGY SAVING AT ARMY AMMO PLANTS SEE THE FOLLOWING INDIVIDUAL TASKS FOR WORK STATUS.	997.6	540.2	396.1	SEP 79	MAY 81
5 77 4281 A01	PROCESS ENERGY INVENTORY STEAM USAGE MEASUREMENTS AT MAP ARE CONTINUING. OPEN AIR DRY TANKS REQUIRE 126 LBS OF STEAM TO DRY EACH LB OF M6 99 PROPELLANT. IN FORCED AIR DRY BUDGS. 8.1 KG OF STEAM ARE REQUIRED TO DRY EACH KG OF M30 AND AMM PROPELLANTS.	351.8	262.6	84.6	JUN 79	JUL 80
5 77 4281 A04	WASTE HEAT FROM CHEMICAL REACTIONS ALL WORK CONDUCTED WITH FY77 FUNDING HAS BEEN COMPLETED.	192.3	64.2	129.0	AUG 79	MAY 81
5 77 4281 A08	CAVITATIONAL REMOVAL OF EXPLOSIVES THE FINAL CONTRACTORS REPORT WAS PUBLISHED. REMOVAL OF EXPLOSIVES FROM PROJECTILES USING A CAVITATING JET WAS DEMONSTRATED TO BE SAFE AND CONSIDERABLY MORE EFFICIENT THAN COMPETING METHODS. OVER 200 SAFETY TESTS WERE PERFORMED AT OPER AND HIGHER PRES	297.9	162.4	135.5	SEP 79	DEC 77
5 77 4281 B02	REDUCED FORGING TEMPERATURE REDUCTION OF THE FORGING TEMP TO 2000F PRODUCED ACCEPTABLE 155MM PROJECTILES. ENERGY USAGE WAS SIGNIFICANTLY REDUCED FROM 21,500 SHP/HR AT 2200F TO 16,000 SHP/HR AT 2000F FOR A 25 PER CENT ENERGY SAVINGS UNDER PRODUCTION OPERATION.	98.0	51.0	47.0	SEP 79	DEC 79
5 78 4281	ENERGY SAVING AT ARMY AMMO PLANTS SEE THE FOLLOWING INDIVIDUAL TASKS FOR WORK STATUS.	1,059.5	817.6	168.0	MAR 80	SEP 81

S U M M A R Y P H O J E C T S T A T U S R E P O R T
 MANUFACTURING METHODS AND TECHNOLOGY PROGRAM
 2ND SEMIANNUAL SUBMISSION CY 79 RCS DRANT-301

PROJ NO.	TITLE + STATUS	AUTOMATIZED (\$000)	CONTRACT VALUES (\$000)	EXPENDED LABOR AND MATERIAL (\$000)	ORIGINAL PROJECTED COMPLETE DATE	PRESENT PROJECTED COMPLETE DATE
5 78 4281 A01	PROCESS ENERGY INVENTORY ENERGY MEASUREMENTS ON THE #7242 LAW LINE WERE SUSPENDED BECAUSE PRODUCTION WAS TERMINATED. REPROGRAMMING OF FUNDS IS BEING COMPLETED. ELECTRICAL AND AIRFLOW MEASUREMENTS ARE BEING MADE AT KAAP.	178.0	118.0	60.0	JUL 80	JUL 80
5 78 4281 A04	ENERGY RECOVERY FROM WASTE HEAT THE PROJECT DSN CONCEPT FOR RECOVERING HEAT FROM NC BOILING TUBS WAS COMPLETED. THE SYSTEM PIPING AND TANK DSNs WERE COMPLETED AND ENGR DRAWINGS ARE BEING PREPARED. FOAMGLAS INSULATION WILL BE USED ON THE STORAGE TANKS.	325.0	272.0	51.2	JUN 81	JUN 81
5 78 4281 A05	ENERGY RECOVERY FROM WOOD WASTE THE FEASIBILITY STUDY OF USING WOOD WASTE AS AN ALTERNATIVE ENERGY SOURCE IS COMPLETE EXCEPT FOR THE FINAL REPORT. THE STUDY CONCLUDED THAT WOOD WASTE IS A VIABLE ALTERNATIVE TO FOSSIL FUELS AT NSTL/MSAAP.	75.0	75.0		APR 79	APR 79
5 78 4281 A08	CAVITATIONAL REMOVAL OF EXPLOSIVES CONTRACTOR REPS VISITED IOWA AAP IN JUL 79 TO DISCUSS THE SPECIFICS OF THE PHASE I EFFORT. THE PHASE I DESIGN EFFORTS HAVE BEEN COMPLETED. PROCUREMENT AND FABRICATION OF SYSTEM COMPONENTS HAVE BEEN INITIATED. IT IS EXPECTED TO BE COMPLETED IN MAR 80.	295.0	275.0	17.5	SEP 81	SEP 81
5 78 4281 B04	WASTE HEAT RECOVERY THE CONTRACTOR'S COPY OF THE FINAL REPORT WAS RECEIVED. THE RPT INDICATES THAT THE RILLET HEATING FURNACES AT SCRANTON AAP ARE THE SINGLE LARGEST CONSUMERS OF ENERGY AND ALSO WASTE THE MOST HEAT. A WASTE HEAT BOILER RECOVERY SYSTEM WAS RECOMMENDED.	117.7	77.6	39.3	MAY 80	MAY 80
5 79 4281	CONSERVATION OF ENERGY AT ARMY AMMUNITION PLANTS SEE THE FOLLOWING INDIVIDUAL TASKS FOR WORK STATUS.	1,285.0	767.3	363.2	JUL 80	MAY 81
5 79 4281 A01	PROCESS ENERGY INVENTORY DURING THIS FIRST YEAR AT IAAP, THE MOST ACTIVE LINE WILL BE SURVEYED. WORK COMPLETED TO DATE INCLUDES THE ESTAB OF AUDIT METH, PROCUREMENT OF INSTRUMENTATION INCLUDING A VELOMETER AND INDUSTRIAL ANALYZER, AND INITIATION OF A MELT-POUR SURVEY.	193.0	142.9	22.3	JUL 80	JUL 80
5 79 4281 A02	OPTIMIZED INSULATION A RESIN IMPREGNATED FIBERGLASS MATERIAL (EGAMGLAS) HAS BEEN SELECTED AS THE MOST PROMISING MATL BECAUSE OF ITS NON-FLAMMABLE QUALITIES AND ITS NON-SPARKING CHARACTERISTICS. A MASTIC THAT WILL NOT BECOME BRITTLE WITH AGE OR TEMPERATURE VARIATIONS WAS PICKED.	193.0	103.0	41.8	OCT 79	SEP 80

S U M M A R Y P R O J E C T S T A T U S R E P O R T
 2ND SEMIANNUAL SUBMISSION CY 79 RCS DRCT-301

MANUFACTURING METHODS AND TECHNOLOGY PROGRAM

PROJ NO.	TITLE + STATUS	AUTHORIZED (\$000)	CONTRACT VALUES (\$000)	EXPENDED LABOR AND MATERIAL (\$000)	ORIGINAL PROJECTED COMPLETE DATE	PRESENT PROJECTED COMPLETE DATE
5 79 4281 A03	SYNTHETIC NATURAL GAS FOR PROCESS OPERATIONS MOB GAS USAGE RATES WERE ESTABLISHED FOR THE SAR PLANT, NAC/SAC, INVERT GAS GENERATION AND RED WATER TREATMENT OPNS. THE USAGE WAS CALCULATED IN BTU/HR SO THAT THE QUANTITY OF GAS CAN BE ESTABLISHED FOR ANY GAS INDEPENDENT OF ITS CALORIFIC CONTENT.	257.0	239.0	3.0	SEP 79	AUG 80
5 79 4281 A04	ENERGY RECOVERY FROM WASTE HEAT EQUIPMENT FOR THE SYSTEM TO RECOVER WASTE HEAT FROM VC BOILING TUBS WAS ORDERED.	515.0	239.0	254.1	JUN 80	MAY 81
5 79 4281 A04	WASTE HEAT RECOVERY A CONTRACT WITH THREE PHASES WAS LET FOR THE DESIGN OF A WASTE HEAT BOILER SYSTEM, PHASE 1, FACILITIES REVIEW AND WASTE HEAT MEASUREMENTS, HAVE BEEN INITIATED.	127.0	44.0	42.0	AUG 79	MAY 80
5 80 4281	CONSERVATION OF ENERGY AT ARMY AMMUNITION PLANTS THIS PROJECT WAS JUST FUNDED. NO STATUS REPORT IS REQUIRED.	1,234.0				
5 78 4285	TNT EQUIVALENCY TESTING FOR SAFETY ENGINEERING REPORT PREPARED ON TNT EQUIVALENCY OF COMP A3 AND COMP C4. TESTING COMPLETED FOR BULK AND PRESSED BILLETS OF LX14.	394.0	100.0	100.0		
5 79 4285	TNT EQUIVALENCY TESTING FOR SAFETY ENGINEERING TESTING AND REPORT COMPLETED ON M42 GRENADES AND M783 PROJECTILES. TEST PLANS PREPARED FOR OCTOL 75/25, HMX AND RDX. ARRCDH SAFETY APPROVED OF OCTOL AND HMX TEST PLANS.	425.0				
5 80 4285	TNT EQUIVALENCY TESTING FOR SAFETY ENGINEERING NO WORK PERFORMED DURING THIS PERIOD.	414.0				
5 78 4288	EXPLOSIVE SAFE SEPARATION AND SENSITIVITY CRITERIA SAFE SEPARATION TESTS WERE COMPLETED FOR FLAKE TNT, 168 LBS AND 155MM M883 HE PROJECTILE TRANSFER PALLET. OTHER TESTS SCHEDULED AWAITING DELIVERIES OF EXPLOSIVES.	611.0				
5 79 4288	EXPLOSIVE SAFE SEPARATION AND SENSITIVITY CRITERIA TESTING WAS COMPLETED ON CASED TNT IMPACTED WITH PRIMARY AND SECONDARY FRAGMENTS, SAFE SEPARATION TESTS FOR PROJECTILES, GRENADE RING PACKS AND MINES ARE IN-PROCESS ON AWAITING PLAN FINALIZATION OR DELIVERY OF NECESSARY QUANTITIES.	611.0				
5 80 4288	EXPLOSIVE SAFE SEPARATION AND SENSITIVITY CRITERIA THIS IS THE SIXTH PROJECT FUNDED FOR THE 4288 EFFORT, THE SIX TOTAL FUNDS AUTHORIZED ARE OVER \$3.5 MILLION.	767.0				

S U M M A R Y P R O J E C T S T A T U S R E P O R T
 MANUFACTURING METHODS AND TECHNOLOGY PROGRAM
 2ND SEMI-ANNUAL SUBMISSION CY 79 RCS DRCHT-301

PROJ NO.	TITLE + STATUS	AUTHO- RIZED (\$000)	CONTRACT VALUES (\$000)	EXPENDED LABOR AND MATERIAL (\$000)	ORIGINAL PROJECTED COMPLETE DATE	PRESENT PROJECTED COMPLETE DATE
5 78 4269	HAZARD CLASSIFICATION OF PROPELLANTS AND EXPLOSIVES DRAFTS OF FINAL REPORTS ON HAZARDS CLASSIFICATION OF AVTD MULTI-BASE DRYER AND IN-PROCESS MATERIALS WERE PREPARED. SCALED-UP DUST REACTION TESTS WERE CONDUCTED ON IGNITER AND TRACER COMPOSITIONS.	214.0	115.0	84.8	DEC 78	MAR 80
5 77 4291	BLAST EFFECTS IN THE MUNITIONS PLANT ENVIRONMENT TESTS WERE COMPLETED TO VALIDATE OVER PRESSURE DESIGNS ON A STRENGTHENED STEEL STRUCTURE. FINAL REPORT IS BEING PREPARED	350.0	176.0	144.0	JUN 78	JAN 80
5 79 4291	BLAST EFFECTS IN THE MUNITIONS PLANT ENVIRONMENT CONTRACT WAS AWARDED FOR PREPARATION OF STEEL DESIGN MANUAL, SAFETY CRITERIA AND DESIGN PROCEDURES FOR ALTERNATE CONSTRUCTION MATERIALS.	235.0	80.0	25.3	SEP 80	SEP 80
5 80 4291	BLAST EFFECT IN THE MUNITION PLANT ENVIRONMENT THIS PROJECT WAS JUST FUNDED. NO STATUS REPORT IS REQUIRED.	404.0				
5 80 4298	EVALUATION OF HEXAMINE RECYCLE ON MAAP 8-LINE THIS PROJECT WAS JUST FUNDED. NO STATUS REPORT IS REQUIRED.	455.0				
5 77 4301	ACCEPT PLAN FOR CONTINUOUSLY PROD MULTIBASE CANNON PROP-CAM BALLISTIC TESTS OF M30 LOTS OF PROPELLANT FOR THE M456 CARTRIDGE, 105MM, HAVE BEEN COMPLETED AT ARRADCOM. LATEST DESIGN OF THE DYNAGUN HAS BEEN ASSEMBLED.	110.0	15.0	95.0	JAN 77	JUN 80
5 76 4301	ACCEPT PLAN- CONT PRODUCTION MULTI-BASE CANNON PROPELLANTS M30 BALLISTIC TESTING HAS BEEN COMPLETED.	395.0	180.0	215.0	OCT 76	NOV 79
5 77 4301	ACCEPT PLAN-CONT PRODUCTION MULTI-BASE CANNON PROPELLANTS THE LATEST DESIGN OF THE DYNAGUN HAS BEEN FABRICATED AND ASSEMBLED. M30 PROPELLANT IS BEING MANUFACTURED AT RAAP.	500.0	230.0	270.0	MAY 78	JUN 80
5 79 4305	PON TECH FOR IMPROVED WP 155MM SMOKE MUNITION (XM825) COMPLETION OF DETAIL DRAWINGS OF THE NOZZLES AND VOLUMETRIC CYLINDERS WAS DELAYED BECAUSE THE FINAL DESIGN SELECTION FOR THE XM825 HAS NOT BEEN MADE AND THE VOL OF WP REQUIRED CANNOT BE FINALIZED UNTIL THAT DECISION IS MADE.	265.0		90.0	JUN 80	JUN 80
5 79 4309	PROCESS DEVELOPMENT FOR 120MM TANK AMMUNITION THE MANUFACTURE OF NC WAS SUCCESSFULLY COMPLETED IN THE FIRST ATTEMPT. BOILING TIMES WERE RELATED TO VISCOSITY. THE LOADING PROCESS PARAMETERS AND METHODS DEVELOPED BY THE R&D LOADING STUDIES WERE ANALYZED.	795.5	464.0	131.0	NOV 80	NOV 80

MANUFACTURING METHODS AND TECHNOLOGY PROGRAM
 S U M M A R Y P R O J E C T S T A T U S R E P O R T
 2ND SEMIANNUAL SUBMISSION CY 79 RCS DRCHT-301

PROJ NO.	TITLE + STATUS	AUTHORIZED (\$000)	CONTRACT VALUES (\$000)	EXPENDED LABOUR AND MATERIAL (\$000)	ORIGINAL PROJECTED COMPLETE DATE	PRESENT PROJECTED COMPLETE DATE
5 80 4309	PROPELLANT PROCESS DEVELOPMENT FOR 120MM TANK AMMUNITION THIS PROJECT WAS JUST FUNDED, NO STATUS REPORT IS REQUIRED.	3,726.0				
5 78 4310	DMSO RECRYSTALLIZATION OF MMX/RDX UNIT DRIVE OUT TESTS WERE CONDUCTED ON THE EVAPORATOR/RECTIFIER COLUMN, CRYSTALLIZERS, AND WASHER SCREENERS OF THE DMSO PILOT PLANT. A NUMBER OF DEFICIENCIES WERE NOTED AND MODIFICATIONS WERE MADE TO PROVIDE ACCEPTABLE OPERATION.	196.0	170.0	26.0	AUG 79	MAR 80
5 79 4310	DMSO RECRYSTALLIZATION OF MMX/RDX CONTINUOUS OPERATION OF THE DMSO PILOT LINE WAS SUCCESSFULLY DEMONSTRATED. ALL PLANNED CLASSES OF RDX AND MMX WERE PRODUCED WITH SOME PROCESS MODIFICATIONS. PILOT PLANT CLEAN UP AND DECONTAMINATION ACCOMPLISHED TO PREPARE FOR NEXT PHASE.	483.0	294.0	39.0	DEC 81	MAY 80
5 80 4310	DMSO RECRYSTALLIZATION OF RDX/MMX THIS PROJECT WAS JUST FUNDED, NO REPORT REQUIRED.	278.0			JUN 81	JUN 81
5 77 4311	DEVELOP AUTOMATED PRODUCTION EQUIPMENT FOR XM 692 THE WOLING MACHINE AND PLUG PULLER ARE BEING INSTALLED. THE OVERLAY/KILL MECHANISM ASSEMBLY MACHINE AND THE DETONATING CURD WRAP MACHINE DEBUGGING IS 90% COMPLETE.	1,452.9	1,184.6	217.1	AUG 78	JUL 80
5 79 4312	INJECTION MOLDING FOR PRODUCTION EXPLOSIVE LOADING CONTRACT AWARDED TO KANSAS AAP TO TEST AND EVALUATE PROTO INJECTION MOLDING DEVICE. EQUIPMENT WAS SHIPPED TO KAAP, INERT TESTING OF MODEL 1 WAS ACCOMPLISHED WITH CANDLE WAX AND PLASTER OF PARIS. SATISFACTORY RESULTS WERE OBTAINED WITH BOTH.	261.0	181.2	58.5	JUN 80	MAR 81
5 80 4312	INJECTION MOLDING FOR PRODUCTION EXPLOSIVE LOADING SCOPE OF WORK PREPARED FOR FOLLOW ON EFFORT AT KANSAS AAP IN WHICH TEST LOADING AND PRODUCTION DESIGN WILL BE ACCOMPLISHED.	279.0			JUL 81	JUL 81
5 78 4322	CHARACTERIZE DORMANCY EFFECT ON ELECTRONIC EQUIPMENT THE FOURTH REACTIVATION OF AN ELECTRONIC CONTROL SYSTEM FOR A CONTINUOUS TNT LINE WAS COMPLETED BY THIRD PARTY OPERATOR USING A START UP PROCEDURE MANUAL. THE PROCEDURE MANUAL AND VIDEOTAPE ARE AVAILABLE AS A PERMANENT RECORD OF THE STARTUP PROCEDURE	185.0	87.0	98.0	MAR 79	MAR 80
5 79 4322	W-T DESIGN/CHAR OF ELEC CONT SYST FOR PROJ FAC CONTACTS AND/OR VISITS WERE MADE AT SEVERAL ARMY AMMO PLANTS TO DISCUSS SCOPES OF WORK OR TECHNOLOGY APPROPRIATE TO METHODOLOGY. CONTRACT ESTABLISHED WITH DOD RELIABILITY ANALYSIS CENTER, FAILURE REPORTING PROCEDURE AND MULTI SITE DOCUMENT STORAGE REV	609.0	199.0	143.0	FEB 80	SEP 81

S U M M A R Y P R O J E C T S T A T U S R E P O R T
 MANUFACTURING METHODS AND TECHNOLOGY PROGRAM
 2ND SEMIANNUAL SUBMISSION CY 79 RCS DRGMT-301

PROJ NO.	TITLE + STATUS	AUTHORIZED (\$000)	CONTRACT VALUES (\$000)	EXPENDED LABOR AND MATERIAL (\$000)	ORIGINAL PROJECTED COMPLETE DATE	PRESENT PROJECTED COMPLETE DATE
5 80 4322	CHARACTERIZE DURMENCY EFFECT ON ELECTRONIC EQUIPMENT THIS PROJECT WAS JUST FUNDED. NO STATUS REPORT IS REQUIRED.	515.0				
5 79 4332	IMPROVEMENTS FOR POTTING ELECTRONIC ASSEMBLY FOR GATOR AEORJET WILL USE NEW POTTING MATERIALS AND ESTABLISH IMPROVED POTTING METHODS FOR BLU 92/8 GATOR MINE. ELECTRONIC ASSY DESIGN REVIEW WAS HELD. GOALS ARE TO INCREASE YIELDS AND REDUCE LABOR. COMPONENT PACKAGING AND ALTERNATE TOOLING WILL BE EXAMINED.	83.0	78.0		APR 80	JUL 80
5 79 4335	ALTERNATIVE PROC F/TITANIUM GYROSCOPE COMPONENTS=COPPERHEAD THE CONTRACTOR'S PROPOSAL IS IN THE NEGOTIATION STAGE WITH FINAL DEFINITIO. TO BE COMPLETED IN DEC 79.	394.0	394.0		FEB 81	MAY 81
5 76 4337	ALTERNATE MATERIALS FOR CURING/MOLDING PROCESS F/AP MINES CONTRACT FOR STUDY OF ACT-3 TO ACCELERATE CURING AWARDED. CONTRACTOR ORGANIZED RESEARCH TEAM AND OBTAINED TEST MATL. IN SITU BONDING STUDY COMPLETED. OVERALL PROJECT WAS RE-DEFINED AND EFFORTS CONCENTRATED, AS A RESULT COMPLETION OF PROJECT ADVANCED.	218.0	33.0	124.7	AUG 78	FEB 81
5 76 4338	DEV AUTO PROCESS + PRTO EQUIP FOR LAP OF M483 155MM PROJ THE 30 PPM MACHINE IS SCHEDULED TO BE COMPLETED AND READY FOR SHIPMENT TO KAAP BY 1 FEB 80. THE COST OF THE MACHINE EXCEEDED ORIGINAL EXPECTATIONS. THE PBM DECIDED TO ABORT THE MAT EFFORT ON A 90 PPM PENDING THE OUTCOME OF THIS PROJECT.	833.6	654.5	166.4	MAR 79	MAY 80
5 78 4341	IMPROVED NITROCELLULOSE PURIFICATION PROCESS THE PLANNED SITE FOR THE INSTALL OF THE CONICELL UNIT IS THE H-LINE AT RAAP. TWO 24-INCH ATTRITION MILLS WILL PREPARE THE NC PRIOR TO ITS PROCESSING IN THE CONICELL. ADDITIONAL FUNDING WAS REQUIRED TO PURCHASE THE CONICELL BECAUSE OF EACH RATE INCREASE	664.9	574.9	90.0	APR 79	JAN 80
5 79 4341	IMPROVED NITROCELLULOSE PURIFICATION PROCESS INFORMATION PERTAINING TO TOTAL OPERATIONAL AND TOTAL DOWNTIME DUE TO MAINTENANCE AND REPAIR OF THE CONICELL WAS OBTAINED FROM A USER. COORDINATION WITH THE OTHER SERVICES WERE INITIATED IN REGARD TO THE REVISION OF THE NC SPECIFICATION.	742.0	673.0	38.4	NOV 80	DEC 80
5 80 4341	IMPROVED NITROCELLULOSE PURIFICATION PROCESS THIS PROJECT WAS JUST FUNDED. NO STATUS REPORT IS REQUIRED.	583.0				
5 77 4343	IMPROVED NITROCELLULOSE PROCESS CONTROL LAB STUDIES HAVE BEEN CONCLUDED. FINAL REPORT HAS BEEN SUBMITTED.	302.0	117.0	185.0	JUL 78	JAN 80
5 78 4343	IMPROVED NITROCELLULOSE PROCESS CONTROL FINAL REPORT IS BEING REVIEWED.	15.0		15.0	JUN 79	JAN 80

MANUFACTURING METHODS AND TECHNOLOGY PROGRAM
 S U M M A R Y P H O J E C T S T A T U S R E P O R T
 2ND SEMIANNUAL SUBMISSION CY 79 MCS DRCMT-301

PROJ NO.	TITLE + STATUS	AUTHORIZED (\$000)	CONTRACT VALUES (\$000)	EXPENDED LABOR AND MATERIAL (\$000)	ORIGINAL PROJECTED COMPLETE DATE	PRESENT PROJECTED COMPLETE DATE
5 80 4344	ESTAB OF WASTE DISPOSAL TECH FOR #607 BINARY PROJECT THIS PROJECT WAS JUST FUNDED. NO STATUS REPORT IS REQUIRED.	108.0				
5 78 4349	MODERNIZATION OF PRESS LOADING FOR MFP PROJECTILES INSTALLATION IS APPROXIMATELY 60 PERCENT COMPLETE. MOST ITEMS ARE IN PLACE. HYDRAULIC SYSTEM PIPING IS INCOMPLETE DUE TO LATE PURCHASE OF TUBING AND FITTINGS. THE LAST ITEM ON CONTRACT, THE FIRST INCREMENT NET-WEIGHER, IS BEING DELIVERED.	250.0		186.4	JUN 80	JUL 80
5 77 4362	REPEAT OF LARGE CAL PROJECTILES TO ELIMINATE BASE SEPARATE MFCAPS WAS BRIEFED ON THE PILOT PLANT STUDY TO DEVELOP A COOLING PROCESS FOR LOADING XM795 DT II TEST QUANTITIES. 205 XM795 PROJ WERE LOADED AT LAAP USING THE PROCESS. PROBLEMS ENCOUNTERED WITH REPEAT + FINNPLS. 160 SEPT TO YUMA FOR DT II TESTING.	394.0	22.8	367.9	APR 78	APR 80
5 80 4405	ULTRASONIC TEST EQUIPMENT FOR 155MM XM795 THIS PROJECT WAS JUST FUNDED. NO STATUS REPORT IS REQUIRED.	523.0				
5 77 4444	BODY FOR #42/M46 GRENADE TWO PROCESSES HAVE BEEN SELECTED FOR FUTURE WORK.	536.0	448.7	86.3	SEP 77	MAR 80
5 78 4444	BODY FOR #42/M46 GRENADE TWO SCOPES OF WORK HAVE BEEN PREPARED. CONTRACTS ARE DUE TO BE AWARDED IN JAN 80.	626.0		151.0	JUN 79	OCT 80
5 79 4444	BODY FOR #42/M46 GRENADE CONTRACTS ARE DUE TO BE AWARDED IN JAN 80.	563.0	231.0	14.8	SEP 80	OCT 81
5 78 4447	VITROQUANTATIVE PROCESS CONTROL ANALYTICAL SYSTEMS A GAS CHROMATOGRAPHY METHOD WAS DEVELOPED TO DETERMINE CARBONATE. WORK IN POLAROGRAPHIC METHOD FOR DETERMINATION OF SULFUR WAS COMPLETED.	470.0	20.0	320.3	JUL 79	JUL 80
5 78 4449	PROCESS IMPROVEMENT FOR COMPOSITION C-4 EXPERIMENTAL LOTS OF COMP C-4 WERE MANUFACTURED AT HOLSTON AAP AND SHIPPED TO LOUISIANA AAP FOR EXTRUSION, TESTING AND EVALUATION.	917.0	780.0	31.1	OCT 79	MAY 78
5 78 4454	AUTO INSPECTION DEVICE FOR EXPLOSIVE CHARGE IN SHELL-CAM SEE PROJECT NO. 5 80 4454 FOR STATUS. THE 78 FUNDING FOR THIS EFFORT IS INCLUDED IN THE FY 80 AUTHORIZED FUNDS.				JUL 80	APR 82
5 79 4454	AUTO INSPECTION DEVICE FOR EXPLOSIVE CHARGE IN SHELL-CAM SEE PROJECT NO. 5 80 4454 FOR STATUS. THE 79 FUNDING FOR THIS EFFORT IS INCLUDED IN THE FY 80 AUTHORIZED FUNDS.				DEC 81	APR 80

AD-A083 036

MANUFACTURING METHODS & TECHNOLOGY PROJECT EXECUTION
REPORT SECOND HALF CY79(U) ARMY INDUSTRIAL BASE
ENGINEERING ACTIVITY ROCK ISLAND IL H E WEIDNER ET AL.

22

UNCLASSIFIED

MAR 80

F/G 13/8

NL

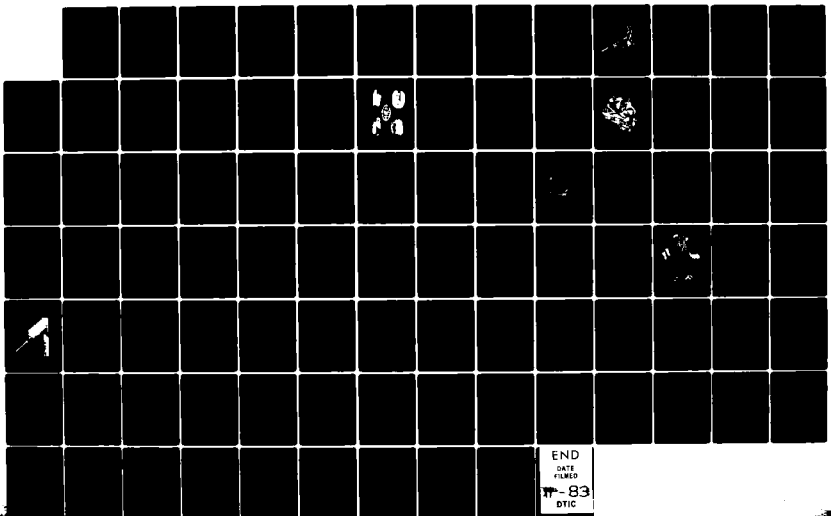

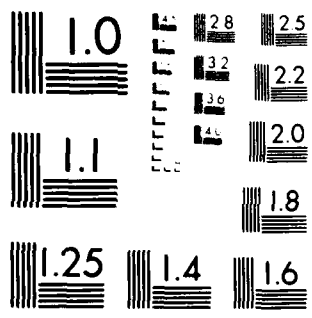

MICROCOPY RESOLUTION TEST CHART
NATIONAL BUREAU OF STANDARDS-1963-A

MANUFACTURING METHODS AND TECHNOLOGY PROGRAM
 S U M M A R Y P H U J E C T S T A Y U S R E P O R T
 2ND SEMI-ANNUAL SUBMISSION CY 79 RCS DRCHT-301

PROJ NO.	TITLE + STATUS	AUTOM- RIZED (\$000)	CONTRACT VALUES (\$000)	EXPENDED LABOR AND MATERIAL (\$000)	ORIGINAL	PRESENT
					PROJECTED COMPLETE DATE	PROJECTED COMPLETE DATE
5 80 4454	AUTO INSP DEVICE EXPLOS CHARGE SHELL (AIDECS) SEE SUBTASKS BELOW FOR PROJECT STATUS.	3,274.0	1,505.0	469.0	APR 82	APR 82
5 80 4454 01	AUTOMATIC INSPECTION DEVICE FOR EXPLOSIVE CHARGE IN SHELL (A THE MIT ENGINEERING MODEL DEMONSTRATION WAS COMPLETED 15 NOV 79. THE PRODUCTION PROTOTYPE DESIGN CONCEPT WAS SUBMITTED NOV 79 FOR REVIEW. THE DESIGN EFFORT IS BEING RESTRUCTURED TO INCORPORATE VERIFICATION TESTS, DOCUMENTATION AND COMPUTER HARDWARE.				APR 82	APR 82
5 80 4454 02	AUTOMATIC X-RAY INSPECTION SYSTEM (AXIS) THE CONTRACTORS COST INCREASE PROPOSAL HAS BEEN COMPLETED AND THE AWARD IS FORTHCOMING. IT HAS BEEN DETERMINED THAT A FINER RESOLUTION WILL BE NECESSARY TO DETECT TRANSVERSE CRACKS. OTHER SPECIAL METHODS FOR DETECTING THESE DEFECTS MAY BE REQUIRED.				AUG 80	AUG 80
5 79 4460	CONT MIXER-ILLUMINANT COMP ANAL + CONTROL SYSTEM ESTABLISHED THAT ON-LINE ANALYSIS IS NOT FEASIBLE BECAUSE OF SPACE LIMITATIONS. TEST MATLS ARE BEING EVALD BY X-RAY FLOURESCENCE. NEUTRON ACTIVATION ANALYTICAL CONCEPT NOW BEING INVESTIGATED AND TESTED. PRESENT FUNDS ONLY SUFFICIENT FOR PROCUREMENT.	236.0	114.0	73.9	DEC 80	JUN 80
5 78 4462	MODERNIZED FAD FOR MULTI-BASE PROPELLANTS EXTENSIVE REWORK FINISHED IN THE RAY AREA. TWO BIDS WERE RECEIVED FOR CAUSTIC SCRUBBERS. HAZARDS ANALYSIS STUDY WAS CONTINUED TO CONSIDER VARIOUS CONCEPT DESIGNS.	592.0	502.0	87.2	AUG 79	MAR 80
5 79 4462	MODERNIZED FAD FOR MULTI-BASE PROPELLANTS SOM WAS REVISED, RESUBMITTED AND APPROVED. A PRELIM MATERIAL AND HEAT BALANCE OF THE PROPOSED PROCESS WAS PREPARED.	528.0	396.0	71.1	JUL 80	SEP 80
5 80 4462	FORCED AIR DRY FOR MULTI-BASE PROPELLANTS FINAL VERSION OF SOM HAS BEEN FORWARDED TO PCO AT ARRCUM.	850.0	509.0		SEP 80	SEP 80
5 78 4466	VAL TNT, CYCLOTOL, AMATEX, OCTOL IN MELT POUR FACILITIES CHECKING OF MELT-POUR PILOT PLANT CONTINUED. A BROOKFIELD VISCOMETER WAS LOCATED BUT FOUND TO BE NOT EXPLOSION PROOF. SEARCH CONTINUES FOR EXPLOSION PROOF MODEL. JOB ORDER FOR TNT TESTING OF PERCENT SOLIDS + VISCOSITY IS BEING REVIEWED BY SAFETY.	200.0	31.3	139.7	DEC 78	MAR 80
5 79 4466	VAL TNT, CYCLOTOL, OCTOL IN MELT-POUR FACILITY CONTRACT AWARDED FOR DEVELOPMENT OF CONTINUOUS MIXER. K-TRON WEIGHFEEDER WAS SELECTED TO FEED TNT TO THE MIXER. PRELIMINARY DESIGNS OF CONTINUOUS MIXER WERE SUBMITTED FOR APPROVAL.	461.0	125.8	89.3	APR 81	APR 81

MANUFACTURING METHODS AND TECHNOLOGY PROGRAM
SUMMARY PROJECT STATUS REPORT
2ND SEMI-ANNUAL SUBMISSION CY 79 RCS DRGHT-301

PROJ NO.	TITLE + STATUS	AUTOMATIZED (8000)	CONTRACT VALUES (8000)	EXPENDED LABOR AND MATERIAL (\$000)		PRESENT PROJECTED COMPLETE DATE	
				ORIGINAL PROJECTED COMPLETE DATE	PROJECTED COMPLETE DATE		
5 78 4469	AUTOMATED INSERTION OF GRENADE LAYERS. EFFORT WAS CONCEN ON THE FAB OF CONCEPT MODELS OF INSPECTION DEVICES FOR THE AUTO INSERTION SYSTEM. DEVICES WERE SUCCESSFULLY DEMONSTRATED. FINAL CONCEPT DRAWINGS FOR INSERTION SYSTEMS ARE BEING PREPARED BY THE CONTRACTOR.	502.0	288.0	211.1	APR 79	NOV 80	
5 79 4469	AUTOMATIC INSERTION OF GRENADE LAYERS. CONTRACTS WERE ISSUED FOR BOTH THE PREPACK ASSEMBLY EQUIP AND THE INSERTION EQUIP. THE CONTRACTS INCLUDE PROVISIONS FOR UNTOOLED STATIONS FOR THE M509 PROJECTILE. A MTG WAS HELD TO COORDINATE EFFORTS OF TWO CONTRACTORS AND TO OBTAIN INPUT F/ THE USER	1,150.0	871.0	17.4	JAN 80	NOV 80	
5 80 4469	AUTOMATIC INSERTION OF GRENADE LAYERS. FUNDS RECEIVED AND FUNDING AWARDS ARE IN PROGRESS.	350.0	125.0		JAN 81	JUL 81	
5 78 4472	DEV EQUIP/ PROC FOR AUTO/MECH FAB OF CENTER CORE PROP BAG. CONTRACTOR HAS COMPLETED FEASIBILITY STUDY AND RECOMMENDED AUTOMATION BE LIMITED TO THE WEB, LINER AND BODY ASSEMBLY. BASED ON AN ROI OF 54 PERCENT IT WILL BE RECOMMEND THAT PM/PBM BUILD AN AUTOMATIC MACHINE FOR THIS ITEM. FY79 FOLLOWON IS CANCELLED.	215.0	147.8	86.0	JAN 79	JUN 80	
5 79 4474	DEHUMIDIFIED AIR FOR DRIVING SINGLE-BASE PROPELLANT ENGINEERING STUDIES OF PREVIOUS INVESTIGATIONS HAVE BEEN INITIATED.	175.0	100.0	14.2	AUG 80	AUG 80	
5 78 4498	CONSOLIDATION + AUTOMATIC ASSEMBLY OF SMALL MINES. IAMP DETERMINED THAT AT MINE AUTOMATION IS NOT COST EFFECTIVE. IN LIEU, SEVERAL LAP OPERATIONS HAVE BEEN SELECTED FOR MECHANIZATION. SOL FOR REVISED TASK I HAS BEEN APPROVED FOR MECHANIZATION OF 4 OPERATIONS.	325.0	130.0	125.0	DEC 80	JUN 80	
5 79 4498	CONSOLIDATION + AUTOMATIC ASSEMBLY OF SMALL MINES. PAD HAS REVIEWED AND APPROVED TECHNICAL SPECIFICATIONS FOR ELECTRONICS LENS TESTER.	572.0	480.0	14.0	SEP 80	MAY 81	
5 80 4498	DEV METH FOR CONSOL AND AUTO ASSY OF SMALL MINES. THIS PROJECT WAS JUST FUNDED. NO STATUS REPORT IS REQUIRED.	592.0					
5 78 4508	PROCESS IMPROVEMENT OF PRESSABLE ROX COMPOSITIONS. FLOWSHEETS WERE PREPARED FOR THE MANUFACTURE OF PILOT BATCHES. A PYSMONT DRYER WAS REQUISITIONED. BATCHES OF COMP A-5 WITH CLASS 1 ROX WERE PRODUCED.	300.0	241.0	56.1	NOV 78	APR 80	
5 79 4508	PROCESS IMPROVEMENT OF PRESSABLE ROX COMPOSITIONS. THE MODIFIED A-7 DRYER SYSTEM WAS EVALUATED. A-7 FINES WERE REDUCED TO ACCEPTABLE LIMITS.	357.0	289.0	47.6	DEC 79	DEC 80	

S U M M A R Y P R O J E C T S T A T U S R E P O R T
2ND SEMIANNUAL SUBMISSION CY 79 RCB DRCHT-301

PROJ NO.	TITLE + STATUS	AUTHORIZED (\$000)	CONTRACT VALUES (\$000)	EXPENDED LABOR AND MATERIAL (\$000)	ORIGINAL PROJECTED COMPLETE DATE	PRESENT PROJECTED COMPLETE DATE
5 80 4503	PROCESS IMPROVEMENT OF PRESSABLE RDX COMPOSITIONS THIS PROJECT WAS JUST FUNDED. NO STATUS REPORT IS REQUIRED.	506.0				
5 76 6200	SMALL CALIBER AMMO PROCESS IMPROVEMENT PROGRAM LOAD + ASSEMBLY NO 1 + 2 WERE ACCEPTED. TESTING ON THE CARTRIDGE MEASUREMENT AND EJECTION SYSTEM WAS COMPLETED. A FINAL REPORT WILL BE COMPLETED IN JAN 80.	1,300.0	298.0	1,002.0	AUG 76	JAN 80
5 77 6200	SMALL CALIBER AMMO PROCESS IMPROVEMENT PROGRAM GULF + WESTERN HAS PRODUCED 1 MILLION CUPS. THESE WILL BE SENT TO LCAAP FOR 5.56 MANUFACTURE. THE FINAL REPORT WAS SUBMITTED.	1,218.5	1,087.2	44.3	FEB 78	JAN 80
5 76 6872	APPLN OF ALT PROCES FOR FAB OF PRECIS METAL PARTS FOR RTFUZE BAYLETTE IS IN THE PROCESS OF FABRICATING THE DIE INSERTS FOR THE REMAINING PINION CONFIGURATIONS TO BE EVALUATED. EVALUATION OF THE AM724 PINION HAS BEEN ADDED TO THE PROJECT SCOPE.	400.0	339.7	44.5	FEB 78	SEP 80
5 77 6894	NEW CONCEPTS FOR MFR AND INSPECT OF 20MM 25MM 30MM AMMO INDIVIDUAL WORK EFFORTS CANNOT BE IDENTIFIED TO SPECIFIC FISCAL YEARS OF FUNDING. THE TASKS ARE THEREFORE ARBITRARILY ASSIGNED TO A FISCAL YEAR AND REPORTED ON BELOW.	1,302.0	746.0	331.0	AUG 79	JUN 80
5 75 6894	MANUFACTURE AND INSPECTION OF CAL.50, 20MM, AND 30MM AMMO FUSE TO PROJECTILE ASSEMBLY- DUE TO AN ANTICIPATED SIGNIFICANT COST GROWTH THIS EFFORT IS BEING REEVALUATED FOR POSSIBLE TERMINATION.	3,760.0	2,220.0	1,514.0	DEC 76	JUN 80
5 76 6894	MANUFACTURE AND INSPECTION OF CAL.50, 20MM, AND 30MM AMMO HEI CHARGING MACHINE- THE TIME SCHEDULES FOR COMPLETION HAVE SLIPPED TO THE POINT THAT THE NEED FOR COMPLETION OF THIS EFFORT TO SUPPORT A FY81 FACILITIES PROJECT IS QUESTIONABLE. ALL PROCUREMENT EFFORT HAS BEEN HALTED.	1,200.0	758.0	439.0	DEC 77	JUN 80
5 77 6894	NEW CONCEPTS FOR MFR AND INSPECT OF 20MM 25MM 30MM AMMO BALLISTIC TEST SUBMODULE- TESTING OF THE TRACE DETECTORS TO SOLVE CIRCUITRY PROBLEMS IS IN PROCESS. A COST ESTIMATE TO CONDUCT A COMPARISON TEST BETWEEN THE BISH AND PRESENT METHODS HAS BEEN SUBMITTED.	2,220.0		581.4	JUN 79	JUL 80
5 79 6553	ADAPT ACOUSTIC ANALYSIS/INSPECT WELDED OVERLAY BANDS-ARTYSHL CONTRACT PROPOSAL HAS BEEN REVIEWED AND APPROVED. PREPARATION OF OPERATING INSTRUCTIONS AND CALIBRATION PROCEDURES ARE 30 PERCENT COMPLETE.	95.0		16.5	MAY 80	MAY 80
5 76 6557	CONTINUOUS PROPELLANT DRYING SALT COATING AND GLAZING. EXTENSIVE TESTING OF THE FEED SYSTEM USING PVC AS AN INERT SIMULANT FOR BALL PROPELLANT HAS CONFIRMED THE OPERABILITY OF MOST OF THE FEED SYSTEM AND HAS IDENTIFIED PROBLEM AREAS AS WELL. PROJ SUSPENDED TO 1 APR 80 TO AVOID HIGH USAGE AND COST OF STEAM	862.0	811.0	51.0	DEC 76	JUL 80

MANUFACTURING METHODS AND TECHNOLOGY PROGRAM
 S U M M A R Y P R O J E C T S T A T U S R E P O R T
 2ND SEMIANNUAL SUBMISSION CY 79 RCB DRGNT-301

PROJ NO.	TITLE + STATUS	AUTHOR- RIZED	CONTRACT VALUES	EXPENDED LABOR AND MATERIAL	ORIGINAL PROJECTED COMPLETE DATE	PRESENT PROJECTED COMPLETE DATE
3 77 6596	BALL PROPELLANT PILOT PLANT STUDIES THE CONTINUOUS WET LINE IS INSTALLED AND BEING CHECKED OUT. HAZARD ANALYSIS COMPLETED. COMPUTER DATA LOGGING AND DISPLAY CHECKED OUT AND MODIFIED. FINAL REPORT WILL BE ISSUED DURING THE FIRST HALF OF 1980.	1,095.0	894.0	161.0	JUL 78	MAR 80
5 78 6596	BALL PROPELLANT PILOT PLANT STUDIES THE FEASIBILITY OF USING AN EXTERNAL LACQUER MIXER WAS DEMONSTRATED ON LACQUERS WITH UP TO 70 PCT H2O. THIS IS EQUIV TO 235 PCT H2O ON A NC BASE. THE 10 GAL SCALING SUBTASK WAS COMPLETED. DUP OF YIELDS FROM 100 GAL AND PROD STILLS WAS NOT OBTAINED.	1,618.0	1,075.0	36.0	JAN 79	JUL 81
5 76 6599	2ND GENER ELEC-OPTC PROJ CAVITY INS EG FOR 155-175MM PROJUS TWENTY-FOUR #107, 155MM PROJECTILE BODIES WITH INTERNAL DEFECTS FOR USE AS STANDARDS HAVE BEEN RECEIVED BY ARRADCOM. EIGHT BODIES WITH NO DEFECTS HAVE BEEN SHIPPED TO THE CONTRACTOR.	243.5	125.5	7.4	SEP 77	MAY 80
5 76 6628	AUTOMATED INSPECT OF MAT, FUZE COMPONENTS-MOVE, PLATES- CONTRACTOR HAS REPROGRAMMED THE MACHINE AND BUILT FIXTURES TO INSPECT THE #577, #180 FUZE PLATES. PROBLEMS ARE BEING EXPERIENCED WITH THE COMPUTER WHICH IS DELAYING THE COMPLETION OF THIS PROJECT	250.0	198.6	43.4	JAN 77	SEP 80
5 77 6632	AUTO INSPECTION DEVICES FOR ART PROJECTILES IN MOD PLANTS DUE TO COST OVERRUN OF THE EDDY CURRENT SYS, AN ADDITIONAL REQUEST FOR FUNDS WAS PRESENTED TO ARRADCOM. THE OGIVE SYSTEM HAS BEEN DEMONSTRATED BY THE CONTRACTOR. THIS SYSTEM IS BEING SHIPPED TO ARRADCOM.	589.0	395.5	135.5	SEP 78	MAR 80
5 76 6634	MFG DU ALLOYS FOR LARGE CALIBER ARMOR DEFEATING PROJECTILE FINAL REPORT BEING PREPARED.	500.0		499.5	AUG 77	JAN 80
5 77 6634	MFG DU ALLOYS FOR LARGE CALIBER ARMOR DEFEATING PROJECTILE SEE STATUS OF PROJECT 5 79 6634.	698.9	312.4	386.3	JAN 78	APR 81
5 78 6634	MFG DU ALLOYS FOR LARGE CALIBER ARMOR DEFEATING PROJECTILE FINAL REPORT IS BEING PREPARED.	400.0	240.0	79.5	FEB 79	MAR 80
5 79 6634	MFG DU ALLOYS FOR LARGE CALIBER ARMOR DEFEATING PROJECTILE THE FEASIBILITY OF THREAD ROLLING THE BUTTRESS GROOVES HAS BEEN DEMONSTRATED.	542.0	25.0	69.4	AUG 80	APR 81
5 77 6640	PROD CONTROL/QA OF SHAPED CHG LINERS BY AUTO X-RAY ANAL THE CONTRACT TO DIAMOND MACHINE, LOAD, AND STATICALLY TEST FIRE HAS BEEN AWARDED. PRELIMINARY MACHINING IS CURRENTLY UNDERWAY TO REMOVE EXCESS MATERIAL IN THE GEN LINERS. THE ARRACOM DETONATORS AND EXPLOSIVE IS SCHEDULED TO ARRIVE IN MID JAN 1980.	165.0	49.7	96.8	JUN 78	MAR 80

S U M M A R Y P R O J E C T S T A T U S R E P O R T
 2ND SEMIANNUAL SUBMISSION CY 79 RCS DRGMT-301

PROJ NO.	TITLE + STATUS	AUTHORIZED (\$000)	CONTRACT VALUES (\$000)	EXPENDED LABOR AND MATERIAL (\$000)	ORIGINAL PROJECTED COMPLETE DATE	PRESENT PROJECTED COMPLETE DATE
5 78 6654	NOT FOR QC IN MFR OF ADVANCED FRAGMENTING STEEL SHELLS THE DESIGN AND FABRICATION AND CHECK-OUT OF THE PROTOTYPE HAS PROGRESSED SATISFACTORILY. TWO PROBLEMS HAVE BEEN ENCOUNTERED, HYD SYSTEM MOTOR IS TOO SMALL, NOSE GRIP ALLOWS TOO GREAT OF DEFLECTION IN THE MAGNETIC FIELD.	500.0	540.0	14.6	JAN 80	JAN 80
5 77 6678	EVALUATION OF AQUA QUENCH UNDER PRODUCTION CONDITIONS PRODUCTION TESTING OF VARIOUS SYNTHETIC QUENCHANTS IS CONTINUING.	299.9	275.7	24.2	MAR 78	MAR 80
5 78 6681	PROCESS PARAMETERS FOR PRODUCTION FORMING OF PROJECTILES ROTARY FORGING TRIALS HAVE BEEN CONDUCTED. SQUEEZE CASTING TRIALS HAVE ALSO BEEN CONDUCTED.	600.0	243.3	207.8	JUN 79	MAY 80
5 79 6682	SIMULATION OF AMMUNITION PRODUCTION LINES DATA WAS COLLECTED FOR A PERIOD OF 20 DAYS ON THE OPERATION OF METAL PARTS PRODUCTION LINE(155MM M483). DATA WAS ANALYZED AND VALUES WERE DETERMINED FOR MEAN TIME BETWEEN FAILURE AND MEAN TIME TO REPLACEMENT FOR EQUIPMENT. LINE SIMULATED USING GENMOD.	170.0		89.0	NOV 80	FEB 81
5 77 6683	PRODUCTION OF TUNGSTEN BASE ALLOY PENETRATORS FOR AP MUNIT TUNGSTEN CORE PROCESS PARAMETERS HAVE BEEN STATISTICALLY LINKED TO MECHANICAL PROPERTIES AND SCALED BALLISTIC PERFORMANCE.	500.0	275.0	142.9	APR 78	FEB 80
5 78 6683	PRODUCTION OF TUNGSTEN BASE ALLOY PENETRATORS FOR AP MUNIT THE LAST M 735 SMALL SCALE BALLISTIC TEST SAMPLES HAVE BEEN SUBMITTED FOR TESTING.	927.0	330.0	104.0	AUG 79	APR 80
5 78 6693	BALL PROPELLANT DETERRENT COATING-CAM RELATED ADDITIONAL DATA ON VOL CONCENTRATION OF DBP VS DBP GLOBULE SIZE WILL BE INCLUDED IN REPORT. BIDDERS FOR CONTROL SYSTEM PROCUREMENT WERE 3 TO 7 TIMES THE GOVT EST. SINCE DISCREPANCY SO LARGE SCOPE OF WORK HAS BEEN REVISED AND SIMPLIFIED.	167.0		132.0	AUG 80	SEP 80
5 79 6693	BALL PROPELLANT DETERRENT COATING-CAM RELATED A SERIES OF DETERRENT COATING RUNS HAS STARTED TO QUANTIFY THE EFFECT OF TEMP ON THE DEPTH OF DETERRENT IMPREGNATION AT 3 DIFF. CONCENTRATIONS. INITIAL RESULTS SHOW INCREASING NONLINEARITY BETWEEN PEN DEPTH AND TEMP AT INCREASING DETERRENT CONCENTRS.	171.0	28.0	49.0	NOV 80	JAN 81
5 79 6716	MATH MODEL OF FORMING OPERATIONS FOR ARTILLERY DESIGN CONTRACT WAS PLACED WITH BATTELLE COLUMBUS LABORATORIES.	306.0	269.7	10.2	JUN 80	AUG 80
5 78 6725	AUTOMATED INERTIA BANDING MACHINE FOR ARTILLERY MUNITIONS OPTIMIZATION OF INERTIA FEEDING PARAMETERS CONTINUES.	325.0	250.0	55.0	APR 80	FEB 80

MANUFACTURING METHODS AND TECHNOLOGY PROGRAM
 S U M M A R Y P H O T O C O P Y S T A T U S R E P O R T
 2ND SEMIANNUAL SUBMISSION CY 79 RCB DRGMT-301

PROJ NO.	TITLE + STATUS	AUTHOR- RIZED (8000)	CONTRACT VALUES (8000)	EXPENDED LABOR AND MATERIAL (8000)	ORIGINAL PROJECTED COMPLETE DATE	PRESENT PROJECTED COMPLETE DATE
5 78 6736	TECH READINESS ACCEL THRU COMPUTER INTEGRATED MFG (CAD) NO NEW ACCOMPLISHMENTS TO REPORT FOR THIS REPORT PERIOD, UNDER THIS FISCAL YEAR OF FUNDING. REFERENCE IS MADE TO PROJECT 6796736.	100.0	31.0	69.0	NOV 78	JUN 80
5 79 6736	TECH READINESS ACCEL THRU COMPUTER INTEGRATED MFG (CAD) PRIME CONTRACTOR, JAMES J. CHILDS ASSOC. INC., HAS DEVELOPED ARCHITECTURE DIAGRAMS COVERING THE MANUFACTURING STRUCTURE OF TWO AMMUNITION METAL PARTS PRODUCERS. ONE COMPONENT PATH OF EACH HIERARCHICAL TREE HAS BEEN PREPARED AND DIAGRAMS REVIEWED.	256.0	155.0	49.6	SEP 79	SEP 81
5 80 6736	TECH READINESS ACCEL THRU COMPUTER INTEGRATED MFG (CAM) THIS PROJECT HAS JUST FUNDED. NO STATUS REPORT IS REQUIRED.	290.0				
5 79 6738	USE OF ULTRA-HI SURFACE SPEEDS F/METAL REMOVAL, ARTY SHELL PLASMA ARC EQUIP DELIVERED 19 NOV 79. INSTALLATION AND TRIALS ARE EXPECTED DURING DEC 79. CONTRACT PLACED 19 NOV 79 FOR CONDUCT OF HIGH SPEED MACHINING STUDIES.	181.0	149.1	18.1	SEP 80	SEP 80
5 80 6738	ULTRA-HIGH SPEED METAL REMOVAL, ARTILLERY SHELL THIS PROJECT HAS JUST FUNDED. NO STATUS REPORT IS REQUIRED.	354.0				
5 78 6748	SCAMP POLLUTION ABATEMENT WASTE SAMPLES HAVE BEEN TAKEN AND ANALYZED TO CONFIRM COMPOSITION AND LOADING. LANCY HAS PURCHASED OR ORDERED ALL MAJOR EQUIPMENT ITEMS FOR THE SYSTEM. SITE PREPARATION HAS BEEN INITIATED	310.0	193.6	46.7	JAN 81	AUG 80
5 79 6748	SCAMP POLLUTION ABATEMENT SEE STATUS OF 5 78 6748.	77.0	50.1	21.0	AUG 80	OCT 80
5 78 6753	METHODS FOR ORIENTING AND FEEDING SMALL CAL AMMO INSUFFICIENT FUNDS REMAIN TO COMPLETE THIS PROJECT. DRGMT APPROVED A \$75,000 CUST INCREASE TO ALLOW THIS PROJECT TO CONTINUE. THIS PROJECT SEEMS TO BE BEHIND SCHEDULE BUT IT IS IRRELEVANT SINCE THE ACTUAL EFFORT IS COMPLETELY DIFFERENT THAN PROPOSED	400.0	322.0	76.0	MAR 79	JUN 80
5 78 6760	DRYING OF LOW DENSITY BALL PROPELLANT THE LOWEST DENSITY PROPELLANT ACHIEVED THUS FAR IS 0.546/CC VS A GOAL OF 0.36/CC. FURTHER BATCHES WILL BE MADE WITH HIGHER ETHYL ACETATE TO NITROCELLULOSE RATIOS. A HAZARDS ANALYSIS OF THE SMALL FLUID BED DRYER REMAINS TO BE CARRIED OUT IN THIS PROJ	118.0	4.8	94.7	AUG 81	MAR 80
5 79 6760	DRYING OF LOW DENSITY BALL PROPELLANT AFTER EVALUATION, A 7-MON CONTRACT WAS AWARDED FOR A SMALL FLUID BED DRYER. THE PRELIMINARY PROCESS DESIGN WAS REVIEWED. OTHER MINOR REVISIONS WERE MADE IN THE FORMAL SUBMISSION RECD IN NOV. A DETAILED REVIEW OF THE PRELIMINARY DESIGN IS IN PROGRESS.	101.0	18.0	40.3	JAN 81	JAN 81

MANUFACTURING METHODS AND TECHNOLOGY PROGRAM
 S U M M A R Y P H O J E C T S T A T U S R E P O R T
 2ND SEMI-ANNUAL SUBMISSION CY 79 RCS ORCMT-301

PROJ NO.	TITLE + STATUS	AUTMO- RIZED (\$000)	CONTRACT VALUES (\$000)	EXPENDED ORIGINAL		PRESENT	
				LABOR AND MATERIAL (\$000)	PROJECTED COMPLETE DATE	PROJECTED COMPLETE DATE	PROJECTED COMPLETE DATE
5 78 6774	MANUFACTURING METHODS FOR APDS PROJECTILE THE SCOPE OF THIS PROJECT HAS BEEN REDUCED TO INJECTION HOLDING OF THE DISCARDING SABOT. A MOLD CONCEPT HAS BEEN DEVELOPED AND CONTROL REQUIREMENTS ESTABLISHED. THIS PROJECT IS APPROXIMATELY ONE AND A HALF YEARS BEHIND SCHEDULE.	300.0	249.0	50.0	NOV 79	JAN 81	
5 79 6774	MANUFACTURING METHODS FOR APDS PROJECTILE NONE OF THE MILESTONES ASSOCIATED WITH THIS FY OF THE EFFORT HAVE BEEN STARTED.	695.0	712.0	43.0	NOV 79	JAN 81	

A R R C O M - A R R A D C O M (WEAPONS)

CURRENT FUNDING STATUS, 2ND CY79

FISCAL YEAR	NO. OF PROJECTS	AUTHORIZED FUNDS (\$)	* CONTRACT ALLOCATED (\$)	* FUNDING EXPENDED (\$)	* INHOUSE REMAINING (\$)	* FUNDING EXPENDED (\$)
73	1	536,000	369,900	369,900 (100%)	166,100	113,800 (68%)
74	0	0	0	0 (0%)	0	0 (0%)
75	2	270,000	193,100	193,100 (100%)	76,900	73,500 (95%)
76	1	350,000	285,400	214,700 (75%)	64,600	30,600 (47%)
77	0	0	0	0 (0%)	0	0 (0%)
77	16	4,157,300	1,733,400	684,400 (39%)	2,423,900	1,891,600 (78%)
78	21	2,910,800	1,003,700	682,900 (68%)	1,907,100	853,100 (44%)
79	23	3,330,000	496,100	76,500 (15%)	2,833,900	899,100 (31%)
80	30	5,781,500	0	0 (0%)	5,781,500	0 (0%)
81	0	0	0	0 (0%)	0	0 (0%)
82	0	0	0	0 (0%)	0	0 (0%)
TOTAL	96	17,335,600	4,081,600	2,221,500 (54%)	13,254,000	3,861,700 (29%)

AUTHORIZED FUNDING CONTRACT ALLOCATED 24% INHOUSE REMAINING 76%

PRECEDING PAGE BLANK-NOT FILLED

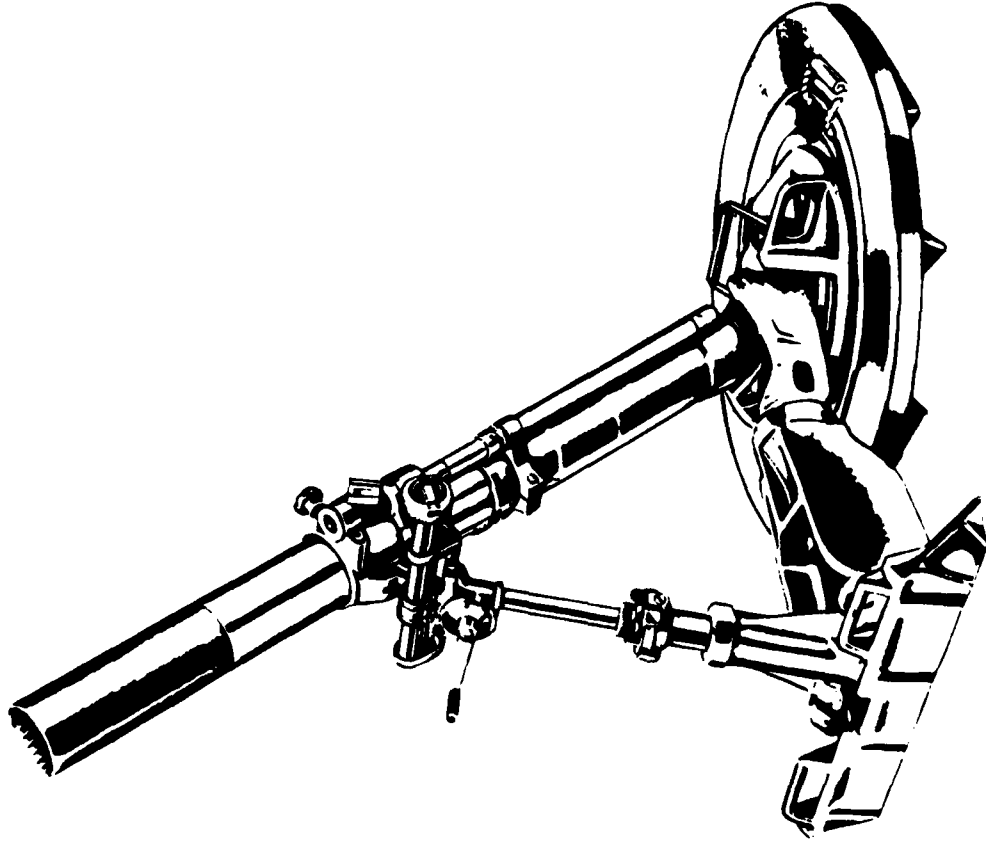

**ARMAMENT R&D COMMAND
ARMAMENT MATERIEL READINESS COMMAND
(ARRADCOM, ARRCOM)
(WEAPONS)**

MANUFACTURING METHODS AND TECHNOLOGY PROGRAM
 S U M M A R Y P R O J E C T S T A T U S R E P O R T
 2ND SEMIANNUAL SUBMISSION CY 79 MCS DRCMT-301

PROJ NO.	TITLE + STATUS	AUTOMO- RIZED (8000)	CONTRACT VALUES (8000)	EXPENDED LABOR AND MATERIAL (8000)	ORIGINAL PROJECTED COMPLETE DATE	PRESENT PROJECTED COMPLETE DATE
6 78 3901	MANUFACTURE OF FLUIDIC AMPLIFIERS BY COLD FORMING THE PILOT PRODUCTION UN WAS ACCOMPLISHED. IT APPEARS THAT AT LEAST TWO BONDING TEMPERATURES 5 DEG. APART, WILL BE REQUIRED DUE TO LAMINATE THICKNESS DIFFERENCE. PARTS FOR ALL TEST FIXTURES HAVE BEEN COMPLETED. WRITTEN TEST PROCEDURES ARE BEING WRITTEN.	290.0	166.0	88.0	SEP 79	MAY 80
6 80 3901	MANUFACTURE OF FLUIDIC AMPLIFIERS BY COLD FORMING (PHASE 2) THIS PROJECT WAS JUST FUNDED. NO STATUS REPORT IS REQUIRED.	343.0				
6 73 7067	APPL. OF HIGH FREQ. INDUCTION HEATING FOR HOT COIL SPRINGS EQUIPMENT HAS BEEN INSTALLED AND MADE OPERATIONAL. PROCESS PARAMETERS ARE NOW BEING ESTABLISHED FOR THE M100 RECOIL SPRING.	536.0	369.9	113.6	JUL 75	SEP 80
6 77 7201	ARTILLERY WEAPON FIRING TEST SIMULATOR ALL THE EQUIP FOR THE SECOND SIMULATOR WITH THE EXCEPTION OF A COMPUTER HAS BEEN DELIVERED. ACCEPTANCE TESTING SHOULD BE COMPLETED BY JUN 80.	820.0	710.3	61.6	OCT 78	MAY 80
6 79 7213	HIGH SPEED CHROME PLATING TECHNIQUE SPECIFICATIONS FOR AUTOMATED SOLUTION FLOW CONTROL SYSTEM HAVE BEEN ESTABLISHED AND PROCUREMENT HAS BEEN INITIATED AND APPROXIMATELY 80 PERCENT OF THE EQUIP HAS BEEN RECD. HEATING AND COOLING EQU	199.0	70.0	117.1	DEC 81	AUG 81
6 77 7313	SIMULATOR FOR PRODUCTION TESTS OF WEAPONS- CAM THIS PROJECT IS ALMOST COMPLETE. A FINAL TECHNICAL REPORT IS BEING PREPARED. 5 AND OPTO-ACOUSTICAL DEVICES. SYSTEM DESIGN OF PILOT PRODUCTION	205.0	85.0	120.0	DEC 77	JUN 80
6 79 7317	OPTIMIZATION OF STEP THREAD TOOLING AN IMPROVED CONFIGURATION WAS DESIGNED FOR MORE EFFICIENT GRINDING OF CUTTER BLADES FOR STEP THREADING. THREE DIFFERENT MATERIALS WERE TESTED IN THREADING OPERATIONS AND ONE WAS SELECTED BASED ON TEST RESULTS.	75.0	18.1	3.9	NOV 80	APR 81
6 79 7482	MODIFIED RIBBON RIFLING GENERATING MACHINE A SPECIFICATION FOR THE PURCHASE OF EQUIPMENT WAS COMPLETED AT THE END OF AUGUST. IT WAS ACCEPTED BY PROCUREMENT IN NOV 1979. BIDS WILL BE OPENED UN 3 FEB 80. CONTRACT AWARD IS SCHEDULED FOR LATE MAY 1980.	136.0		11.9	APR 81	AUG 81
6 77 7485	APPLICATION OF CHEMICAL PROCESSES TO IMPROVE SURFACE FINISH RESULTS OF MANY ELECTROPOLISH CYCLES WERE EVALUATED. THE SYSTEM WAS FOUND TO BE COMPATIBLE WITH GOOD WFR PRACTICES. A CONFORMING ANODE HAS BEEN FAB AND ELECTROPOLISHING TESTS HAVE BEEN INITIATED. FURTHER REFINEMENT VIA COMPUTER CONTROL WILL OCCUR.	309.0		289.0	FEB 78	SEP 80

MANUFACTURING METHODS AND TECHNOLOGY PROGRAM
 S U M M A R Y P R O J E C T S T A T U S R E P O R T
 2ND SEMI-ANNUAL SUBMISSION CY 79 RCB DRG-MT-301

PROJ NO.	TITLE + STATUS	AUTHO- RIZED (8000)	CONTRACT VALUES (8000)	EXPENDED LABOR AND MATERIAL (8000)	ORIGINAL PROJECTED COMPLETE DATE	PRESENT PROJECTED COMPLETE DATE
6 75 7532	SINGLE POINT CUTTING FOR METAL + PLASTIC OPTICS THE ULTRA PRECISION CURVE GENERATOR-MILLING MACHINE DEVELOPED BY PREMO PRECISION INC HAS BEEN DELIVERED TO INTOP DIV, KULLMORGEN COMP, WALLINGFORD, CN. EVALUATIONS WILL BEGIN SOMETIME AFTER APRIL 1980, AS INTOP IS RELOCATING ITS OPERATING FACILITY.	140.0	98.1	40.5	JUN 76	AUG 80
6 79 7555	DYNAMIC PRESSURIZATION STAND, SLIDE BLOCK BRECH MECH THE PURCHASE DESCRIPTION FOR THE INSTRUMENTATION PACKAGE WAS COMPLETED IN JULY 1979. CONTRACT AWARD IS PROJECTED FOR THE FIRST WEEK OF JAN 1980. DYNAMIC PRESSURIZATION STAND=50 PERCENT OF THE STRUCTURE AND 20 PERCENT OF THE HYDRAULICS ARE INSTALLED.	121.0	24.9	0.7	SEP 81	SEP 81
6 76 7580	PILOT AUTO SHOP LOADING AND CONTROL SYSTEM= CAM THE INVENTORY/OPEN ORDER MODULE WAS IMPLEMENTED. SOFTWARE PROGRAMMING CONTINUED ON THE MATERIAL REQUIREMENTS AND CAPACITY PLANNING MODULE. EFFORTS ON THE COST MONITORING AND CONTROL MODULE HAVE BEEN DELAYED PENDING IMPLEMENTATION OF OTHER MODULES.	350.0	285.4	30.6	SEP 78	NOV 80
6 77 7588	ROTARY FORGE INTEGRATED PRODUCTION TECHNOLOGY A NEW PRODUCTION PROBLEM HAS ARISEN. STEEL FROM A NEW VENDOR HAS NOT REACTED THE SAME. A 40 PERCENT REMOURA RATE THROUGH HEAT TREAT IS BEING EXPERIENCED. CURRENT PROJECT EFFORT IS BEING AIMED AT THAT PROBLEM.	260.0	5.8	203.4	DEC 78	SEP 80
6 75 7589	AUTO TARGETING SYS FOR PRODUCTION TEST OF AUTO MPN + AMMO THE FINAL DEBUGGING OF THE TARGETING SYSTEM HAS BEEN DELAYED AS THE ROCK ISLAND ARSENAL FACILITIES HAS NOT RESPONDED TO 16 APR 1979 REQUEST TO ACOUSTICALLY TREAT RANGE NO. 4.	130.0	95.0	33.0	SEP 76	MAR 80
6 79 7605	CHEMICALLY BONDED SAND FOR CLOSE TOLERANCE CASTING DELAYS HAVE BEEN ENCOUNTERED IN CONTRACTING FOR EQUIPMENT.	127.0		20.6	MAR 80	AUG 80
6 80 7605	CHEMICALLY BONDED SAND FOR CLOSE TOLERANCE CASTING THIS PROJECT WAS JUST FUNDED. NO STATUS REPORT IS REQUIRED.	130.0				
6 77 7644	APPLICATION OF INTEGRAL COLOR ANODIZE FOR ALUMINUM SINCE THE LAST REPORTING PERIOD, TREATED COUPONS FROM COOPERATING INTEGRAL COATING ANODIZERS WERE EVALUATED RELATIVE TO CORROSION RESISTANCE, LIGHT FASTNERS AND TABER ABRASION RESISTANCE.	75.0		55.4	APR 78	MAR 80
6 78 7649	COMPUTERIZED PUMPER METALLURGY FURGING DESIGN=CAM COMPUTER PROGRAM IS CONTINUING TO BE DEVELOPED.	102.0	92.1	5.7	AUG 79	APR 80
6 77 7652	COOLANT CHIP EJECTOR, MULTI-OPERATION TOOLING TEST COUNTERBORING HEAD WAS RECEIVED AND INSPECTED. TECHNICAL EVALUATION OF SKIVING WAS COMPLETED, AND AN ENGINEERING SEMINAR WAS SCHEDULED TO PRESENT NEW ROLLER-BURNISHING TOOL DESIGNS AND CAPABILITIES.	65.0		38.2	AUG 78	MAR 80

MANUFACTURING METHODS AND TECHNOLOGY PROGRAM
 S U M M A R Y P R O J E C T S T A T U S R E P O R T
 2ND SEMIANNUAL SUBMISSION CY 79 RCS DRCMT-301

PROJ NO.	TITLE + STATUS	AUTHOR- RIZED (8000)	CONTRACT VALUES (8000)	EXPENDED LABOR AND MATERIAL (8000)	ORIGINAL PROJECTED COMPLETE DATE	PRESENT PROJECTED COMPLETE DATE
6 77 7655	APPLICATION - THERMOARC SPRAY NEAR COATINGS NEAR TESTING OF COMPONENTS HAS BEEN COMPLETED.	70.0	49.9	19.4	MAR 78	DEC 79
6 78 7655	APPLICATION - THERMOARC SPRAY NEAR COATINGS SEE STATUS OF PROJECT 6 77 7655.	62.0	50.0	8.3	AUG 78	MAR 80
6 78 7710	INJECTION MOLDING OF RUBBER OBTURATOR PADS DIFFERENT INJECTION TIME/TEMP CYCLES WERE STUDIED TO DETERMINE OPTIMUM MOLDING CYCLE PARAMETERS. THE NEOPRENE COMPOUND HAS BEEN SUCCESSFULLY INJECTION MOLDED.	77.0		13.5	JUL 79	SEP 80
6 77 7711	ELECTROPOLISHING PROCESS MODELS FOR SMALL BORE WEAPONS WORK TO DATE HAS REVEALED THE IMPORTANCE OF IRON IN THE BATH AS WELL AS THE CORRECT AMOUNT OF WATER, WHICH CAN BE CONTROLLED WITH THE ADDITION OF PHOSPHOROUS PENTOXIDE. ALSO, POSITION OF THE BARREL IN THE BATH AFFECTS METAL REMOVAL.	75.0		74.3	FEB 78	AUG 80
6 77 7714	MULTI-MODE WEAPON + MOUNT IMPEDANCE SIMULATOR (CAM) UNAVOIDABLE DELAYS HAVE BEEN ENCOUNTERED DUE TO FUNDING SHORTAGES. ADDITIONAL FUNDS HAVE BEEN RECEIVED AND THE CONTRACTOR IS EXPECTED TO DELIVER THE SIMULATOR IN JUNE 80. AFTER ACCEPTANCE TESTING A TECH DATA PACKAGE WILL BE PREPARED.	335.0	245.0	40.0	OCT 79	SEP 80
6 77 7716	PROTOTYPE PROD LINE FOR PRESSURE PHOSPHATE COATINGS SEE STATUS OF PROJECT 6 78 7716.	115.0	70.0	43.7	APR 78	MAY 80
6 78 7716	PROTOTYPE PROD LINE FOR PRESSURE PHOSPHATE COATINGS PROCESS HAS BEEN SCALED UP. PIECES HAVE BEEN COATED AND COMPARED TO EARLIER RESULTS.	77.0	50.0	19.5	DEC 79	MAY 80
6 79 7724	GROUP TECHNOLOGY OF WEAPON SYSTEMS DRAWINGS AND ROUTINGS HAVE BEEN CODED. FILES HAVE BEEN ESTABLISHED BASED ON QUANTITIES MANUFACTURED AND PURCHASED. A MACHINE TOOL FILE HAS BEEN ESTABLISHED. ANALYSIS PROGRAMS ARE BEING RUN TO IDENTIFY MACHINING MODULES.	83.0	25.4	3.0	FEB 80	FEB 80
6 77 7726	APPLICATION OF COLD AND WARM ROTARY FORGING DELAYS HAVE BEEN ENCOUNTERED DUE TO PROBLEMS WITH THE GFM ROTARY FORGE.	592.0	312.9	278.9	MAY 79	JUN 80
6 78 7726	APPLICATION OF COLD AND WARM ROTARY FORGING DELAYS HAVE BEEN ENCOUNTERED DUE TO EQUIPMENT PROBLEMS WITH THE GFM ROTARY FORGE.	110.0	9.7	25.8	SEP 79	DEC 80
6 79 7726	APPLICATION OF COLD AND WARM ROTARY FORGING DELAYS HAVE BEEN ENCOUNTERED DUE TO EQUIPMENT PROBLEMS ENCOUNTERED WITH THE GFM ROTARY FORGE.	108.0	29.5	9.6	SEP 80	DEC 80

S U M M A R Y P R O J E C T S T A T U S R E P O R T
2ND SEMIANNUAL SUBMISSION CY 79 RCB DRGMT-301

PROJ NO.	TITLE + STATUS	AUTHORIZED (\$000)	CONTRACT VALUES (\$000)	EXPENDED LABOR AND MATERIAL (\$000)	ORIGINAL PROJECTED COMPLETE DATE	PRESENT PROJECTED COMPLETE DATE
6 79 7727	RECYCLING OF SCRAP GUN TUBES BY ROTARY FORGING PAD HAS ACCEPTED THE USE OF PREFORMS MADE FROM 8 INCH M2A2 SPENT TUBES FOR PRODUCING THE 105 MM M68. WORK HAS BEEN INITIATED FOR MAKING 155 M185 TUBES FROM 175 MM M113 SPENT TUBES.	237.0	7.5	81.6	JUL 81	MAY 81
6 79 7730	MANUFACTURE OF SPLIT RING BREECH SEALS SIX PARTIALLY MACHINED SPLIT RINGS WERE PROCURED, FOUR WERE MACHINED AND TWO WERE SPLIT. EDM SHOWS POTENTIAL IMPROVEMENT OVER EXISTING METHODS OF SPLITTING RINGS. THE CRIMPING PROCESS SHOWS LACK OF UNIFORMITY. A MECH CRIMPING METHOD WILL BE REVIEWED.	157.0		44.9	JUN 80	AUG 81
6 80 7730	MANUFACTURE OF SPLIT RING BREECH SEALS THIS PROJECT WAS JUST FUNDED. NO STATUS REPORT IS REQUIRED.	453.0				
6 77 7741	IMPR INST/INSPECT ANGLE + LINEARITY OF F C INSTS THE LASER FOR THE BREADBOARD ALIGNMENT TEST FIXTURE WAS INSTALLED BUT IT WAS NOT ALIGNED OR OPERATED BECAUSE THE LASER SAFE AREA WHERE IT WILL BE USED IS NOT COMPLETED. WILL USE UNIAIXIAL CRYSTALS + POLARIMETRY TECHNIQUES FOR ALIGNMENT.	130.0	47.3	59.5	APR 78	JUL 80
6 78 7741	IMPR INST/INSPECT ANGLE + LINEARITY OF F C INSTS ARRADCOM ESTABLISHED TEST REQUIREMENTS AND DECIDED PREPARED AN INTERIM DESIGN FOR THE TEST SET. HARDWARE FOR BREADBOARDING THE BIREFRINGENT ANGULAR ALIGNMENT SENSOR WAS RECEIVED.	54.0		42.4	DEC 79	OCT 80
6 78 7743	APPLICATION OF ANTI-FOG CONDUCTIVE FILMS PICATINNY USED RF SPUTTERING TO APPLY INDIUM TIN OXIDE FILMS ON GLASS WINDOWS. CONTACTS WERE DEPOSITED OF GOLD OVER CHROME. 12 VOLTS WERE APPLIED TO HEAT AND DEFOG THE WINDOW. THE FILM ALSO MET DURABILITY REQUIREMENTS. INVENTION DISCLOSURE WAS FILED.	70.0		68.0	FEB 79	SEP 80
6 77 7744	IMPROVED MFG PARAMETERS FOR OPTICS A RESTRUCTURED APPROACH IS NEEDED FOR REVISION OF SPEC MIL-D-13830. THE PAD IS PREPARING A NEW FINAL REPORT. WORK INDICATES THAT SPEC REVISION MUST WAIT UNTIL THE OTHER PROJECTS IN THE SCRATCH AND DIG AREA ARE COMPLETED.	165.0		154.9	APR 78	MAY 80
6 77 7745	DIAMOND TOOL FABRICATION CAPABILITY PERF REQ HAVE BEEN ESTAB, DIAMOND PELLET TOOLS DESIGNED, THE GEOMETRY OF PELLETS ESTAB, TEST LENSES SELECTED, AND SPOT BLOCKS FOR MOUNTING THE LENS BLANK DESIGNED AND FAB. AN UNSOLICITED PROPOSAL FROM ITEK IS BEING EVALUATED.	112.0	50.0	61.3	MAR 78	OCT 80
6 77 7746	IMPROVE DURABILITY HIGH EFFICIENCY REFLECT FILMS NO WORK HAS PERFORMED BECAUSE FUNDS RAN OUT. HAS DEVELOPED A METHOD TO APPLY SILVER TO GLASS WITH ADHERING QUALITY EQUAL TO THAT OF ALUMINUM TO GLASS. DID NOT DEVELOP A COATING TO PROTECT THE SILVER. MULTI-LAYER DIELECTRIC COATING WAS NOT DEVELOPED.	89.0		89.0	MAY 78	JFC 79

MANUFACTURING METHODS AND TECHNOLOGY PROGRAM
 S U M M A R Y P R O J E C T S T A T U S R E P O R T
 2ND SEMIANNUAL SUBMISSION CY 79 ACS DRCHT-301

PROJ NO.	TITLE + STATUS	AUTHOR RIZED	CONTRACT VALUES	EXPENDED ORIGINAL LABOR PROJECTED AND COMPLETE	PRESENT PROJECTED COMPLETE
		(8000)	(8000)	(8000)	DATE
6 77 7753	NOISE SUPPRESSOR FOR PUMPER TYPE RECOIL MECHANISM TESTING MA PROPOSALS TO FABRICATE A NOISE REDUCTION DEVICE ARE BEING EVALUATED.	80.0	60.0	1.9	FEB 80
6 78 7802	ESTABLISH MACHINE TOOL PERFORMANCE SPECIFICATIONS WORKPIECE INSPECTION AND QUAL ASSURANCE PROCEDURES WERE REVIEWED RELATIVE TO MACHINE TOOL PERFORM WITH RESPECT TO ACCURACIES AND MALFUNCTION. MAINT PROCEDURES AND RECORD KEEPING PRACTICES WERE CHECKED IN DETAIL. PREVENTIVE PRACTICES WERE REVIEWED.	195.0	161.5	24.1	DEC 79
6 79 7802	ESTABLISH MACHINE TOOL PERFORMANCE SPECIFICATIONS COMPUTER METHODS DEVELOPED IN FIRST YEAR EFFORT WERE APPLIED IN ANALYZING AND COMPARING MACHINING CYCLE TIMES OF VARIOUS MAKES AND MODELS OF NC MACHINES USED FOR 194 DIFFERENT PARTS OF THE M198 MOUNTZER.	282.0	41.3	0.9	JUN 81
6 78 7807	PROGRAMMED OPTICAL SURFACING EQUIPMENT AND METHODOLOGY (CAM) THIS PROJECT IS FOR DESIGN AND FABRICATION OF A CURVE GENERATING/RADIUS TRUING MACHINE. PROJECT 6 79 7807 IS FOR A GRINDING/POLISHING MACHINED. SEE PROJECT 6 79 7807.	134.0		21.6	DEC 79
6 79 7807	PROGRAMMED OPTICAL SURFACING EQUIPMENT AND METHODOLOGY (CAM) SEE PROJECT 6 78 7807. A PROPOSAL FOR DESIGNING AND FABRICATING THIS MICRO-COMPUTER CONTROLLED EQUIPMENT AS A JOINT EFFORT BETWEEN A MACH TOOL BUILDER, THE INSTITUTE OF OPTICS, AND THE ARMY IS BEING EVALUATED.	139.0		4.9	JUN 80
6 78 7808	LEAK DETECTION TECHNIQUES FOR SMALL SEALED FIRE CON ASSM FABRICATION OF A PROTOTYPE LEAK DETECTION TEST FIXTURE IS PARTIALLY COMPLETE. THE TEST FIXTURE WILL PERMIT THE APPLICATION OF CONTROLLED PRESSURE DIFFERENTIALS BETWEEN THE INTERIOR AND EXTERIOR OF THE SEALED FIRE CONTROL ASSEMBLY. NEED MORE FUNDS, SEE STATUS OF 6 78 7814.	86.0		78.2	APR 79
6 77 7814	SYNTHETIC QUENCHANT FOR HEAT TREATING WEAPON COMPONENTS SEE STATUS OF 6 78 7814.	77.0	20.9	53.4	FEB 78
6 78 7814	SYNTHETIC QUENCHANT FOR HEAT TREATING WEAPON COMPONENTS TESTS ARE UNDERWAY TO DETERMINE THE PROPER QUENCH BATH MAKE-UP FOR RIMS PRODUCTION REQUIREMENTS.	51.0	20.9	11.0	JUN 79
6 78 7825	ELIMINATION OF FACILITATING MOUNTING OPERATIONS BURNISHING WILL IMPROVE SURFACE FINISH AND MEET THE REQUIREMENT. IF INITIAL SURFACE FINISH IS KEPT BELOW 200 RMS, THIS MAY BE DIFFICULT TO ACCOMPLISH.	133.0	12.2	102.0	JUN 79

MANUFACTURING METHODS AND TECHNOLOGY PROGRAM
S U B M A R Y P H O D J E C T S T A T U S R E P O R T
2ND SEMIANNUAL SUBMISSION CY 79 MCS DRCHT-301

PROJ NO.	TITLE + STATUS	AUTHORIZED (\$000)	CONTRACT VALUES (\$000)	EXPENDED LABOUR AND MATERIAL (\$000)	ORIGINAL PROJECTED COMPLETE DATE	PRESENT PROJECTED COMPLETE DATE
6 78 7840	PORTABLE MULTI-DEGREE-OF-FREEDOM SIMULATOR THE SCOPE OF WORK FOR PROCUREMENT OF THE SIMULATOR WAS GENERATED. A REQUEST FOR PROPOSAL WAS PREPARED.	309.0	35.0	35.0	JUN 80	DEC 82
6 80 7820	CONSERVATION OF CRITICAL MATERIALS FOR GUN TUBES THIS PROJECT WAS JUST FUNDED. NO STATUS REPORT IS REQUIRED.	236.0				
6 80 7825	BORE EVACUATOR BORING THIS PROJECT WAS JUST FUNDED. NO STATUS REPORT IS REQUIRED.	111.0				
6 80 7826	HOT ISOSTATIC PRESSING OF LARGE ORDNANCE COMPONENTS THIS PROJECT WAS JUST FUNDED. NO STATUS REPORT IS REQUIRED.	216.0				
6 80 7827	GENERATION OF BASE MACHINING SURFACES THIS PROJECT WAS JUST FUNDED. NO STATUS REPORT IS REQUIRED.	66.0				
6 78 7833	CENTRAL COOLANT SYSTEMS SYSTEM SPECIFICATIONS ARE BEING FINALIZED. THE SYSTEM WILL CONSIST OF A 20000 GAL TANK, MAIN AND BACKUP PUMPS, FIXED COULANT LINES WITH FLEXIBLE HOSES TO THE MACHINES, A SELF CLEANING AUTOMATIC CENTRIFUGE, AND A LIQUID PROPORTIONER.	58.0	49.3	49.3	SEP 79	FEB 80
6 77 7843	ANALYSIS FOR MODERNIZATION OF INDUSTRIAL OPERATIONS PROJECT DEVELOPMENT BROCHURE AND RELATED DOCUMENTATION FOR MILITARY CONSTRUCTION ARMY PROJECTS FOR FY 83/84, AS WERE PREPARED IN SU	563.3	76.3	247.5	FEB 78	DEC 80
6 78 7843	ANALYSIS FOR MODERNIZATION OF INDUSTRIAL OPERATIONS CONTRACT COMPLETED FOR THE DEVELOPMENT OF A MASTER PLAN FOR THE MODERNIZATION OF ROCK ISLAND ARSENAL MANUFACTURING PLANT. ADDITIONAL DATA HAS BEEN ADDED AND A REVISED MASTER PLAN HAS BEEN PREPARED.	441.8	393.8	28.0	JUL 79	DEC 80
6 79 7848	ESTABLISH CUTTING FLUID CONTROL SYSTEM THE SURVEY OF ROCK ISLAND ARSENAL CUTTING FLUID INVENTORY HAS BEEN COMPLETED. A FORMAL AUDIT OF THE PROPOSED CONTRACTOR IS CAUSING SLIPPAGE. THIS PROJECT IS APPROXIMATELY 6 MONTHS BEHIND SCHEDULE	150.0	107.9	20.4	FEB 80	AUG 80
6 80 7848	ESTABLISH CUTTING FLUID CONTROL SYSTEM THIS PROJECT WAS JUST FUNDED. NO STATUS REPORT IS REQUIRED.	158.0				
6 79 7849	APPLICATION OF GROUP TECHNOLOGY TO RIA (CAM) THE MICLASS CLASSIFICATION AND COING SOFTWARE ALONG WITH ANALYSIS MODULES HAVE BEEN IMPLEMENTED ON IN-HOUSE COMPUTER HARDWARE. PERSONNEL HAVE BEEN TRAINED TO USE THE COING SOFTWARE. PARTS ARE BEING CODED AND ADDITIONAL TRAINING IS PLANNED.	127.0	91.5	13.3	FEB 80	MAR 80

MANUFACTURING METHODS AND TECHNOLOGY PROGRAM
 S U M M A R Y P R O J E C T S T A T U S R E P O R T
 2ND SEMIANNUAL SUBMISSION CY 79 RCS ORCMT-301

PROJ NO.	TITLE + STATUS	AUTHORIZED (\$000)	CONTRACT VALUES (\$000)	EXPENDED LABOR AND MATERIAL (\$000)	ORIGINAL PROJECTED COMPLETE DATE	PRESENT PROJECTED COMPLETE DATE
6 80 7989	APPLICATION OF GROUP TECHNOLOGY TO RIA 4FG (CAM) THIS PROJECT WAS JUST FUNDED. NO STATUS REPORT IS REQUIRED.	155.0				
6 79 7983	GROUP TECH CELLULAR MFG FOR FC COMPONENTS ASSEMBLIES THE FIRE CONTROL GROUP IS RELOCATING THE GROUP TECHNOLOGY DATA CENTER. THIS HAS HAMPERED RUNNING THE ANALYSIS PROGRAMS, ANOTHER ANALYSIS PROGRAM FOR PROCESS PLANNING IS BEING BOUGHT.	188.0	80.0	18.5	JUL 80	DEC 80
6 80 7983	GROUP TECHNOLOGY FOR FIRE CONTROL PARTS AND ASSEMBLIES THIS PROJECT WAS JUST FUNDED. NO STATUS REPORT IS REQUIRED.	303.0				
6 79 7985	DIFFERENTIAL SCATTEROMETRY FOR MICROFINISH SURFACES PERFORMANCE REQ. WERE ESTABLISHED. DESIGN HAS BEEN COMPLETED. THE COMPONENTS HAVE BEEN RECEIVED AND THE ASSEMBLY OF THE BREADBOARD ASSEMBLY STARTED.	100.0		80.0	MAR 80	MAR 80
6 80 7985	SMALL ARMS WEAPONS NEW PROCESSES PRODUCTION TECHNOLOGY SCOPE OF WORK FOR THE PROCUREMENT PACKAGE IS BEING PREPARED.	349.5			MAY 81	MAY 81
6 79 7990	IMPROVED FABRICATION AND REPAIR OF ANODES THE DESIGN WORK FOR ALTERATIONS TO THE PIT AREA IS IN PROGRESS. PURCHASE REQUIREMENTS FOR EQUIPMENT AND MATERIALS ARE BEING REVIEWED AND PURCHASE ORDERS PREPARED.	250.0		15.2	JUN 81	JUN 81
6 79 8004	CO-DEPOSITION OF SOLID LUBRICANTS DURING ANODIZING TEST PIECES HAVE BEEN COATED UNDER VARIOUS PROCESSING CONDITIONS. THESE TEST PIECES WILL BE REAR TESTED.	120.0			JAN 80	JAN 80
6 80 8004	CO-DEPOSITION OF SOLID LUBRICANTS DURING ANODIZING THIS PROJECT WAS JUST FUNDED. NO STATUS REPORT IS REQUIRED.	121.0				
6 79 8005	ESTABLISHMENT OF THE SPACE MECHANICAL PLATING PROCESS PARTS HAVE BEEN PLATED AND SOME INITIAL TESTS PERFORMED.	150.0		90.3	DEC 79	MAY 80
6 79 8010	PRODUCTION OF ACOUSTIC MICROWAVE FILTERS THIS IS AN INTENSIVE EFFORT. COMPUTER CONTROLLED ELECTRON BEAM LITHOGRAPHY + ION MILLING WILL BE USED TO PRODUCE FILTERS, RESONATORS AND OPTO-ACOUSTICAL DEVICES. SYSTEM DESIGN OF PILOT PRODUCTION FACILITY HAS COMPLETED. CUMM RESISTS WERE EVALUATED.	233.0		228.0	JUN 80	JUL 80
6 80 8010	PRODUCTION OF ACOUSTIC MICROWAVE FILTERS (CAM) THIS PROJECT WAS JUST FUNDED. NO STATUS REPORT IS REQUIRED.	150.0				
6 79 8017	POLLUTION ABATEMENT PROGRAM ADDITIONAL CHEMICALS FOR BOTH NON-CYANIDE CADMIUM AND COPPER PLATING BATHS HAVE BEEN PROCURED FOR SCALE UP TO PRODUCTION PLATING. APPROPRIATE ANODES AND ZIRCONIUM RACKS HAVE BEEN PURCHASED. TECHNIQUES FOR BLEECHING CYANIDE CHLRS FROM LINES WERE PLANNED.	61.0		11.2	DEC 79	JAN 80

S U M M A R Y P R O J E C T S T A T U S R E P O R T
 MANUFACTURING METHODS AND TECHNOLOGY PROGRAM
 2ND SEMI-ANNUAL SUBMISSION CY 79 RCB DRGNT-301

PROJ NO.	TITLE + STATUS	AUTOMATED RIZED (8000)	CONTRACT VALUES (8000)	EXPENDED LABOR AND MATERIAL (8000)	ORIGINAL PROJECTED COMPLETE DATE	PRESENT PROJECTED COMPLETE DATE
6 80 8017	POLLUTION ABATEMENT PROGRAM THIS PROJECT HAS JUST FUNDED. NO STATUS REPORT IS REQUIRED.	171.0				
6 80 8024	HIGH SPEED ABRASIVE WHEEL GRINDING THIS PROJECT HAS JUST FUNDED. NO STATUS REPORT IS REQUIRED.	324.0				
6 79 8025	ELECTRONIC PROFILE HEADOUT GAGE FOR POWDER CHAMBER CONTROLS SEVERAL GAGING MANUFACTURERS OF BOTH CONTACTING AND NON-CONTACTING TYPE GAGES HAVE DEMONSTRATED THEIR PRODUCTS. MATERIELLIT HAS SELECTED THE CONTACTING TYPE AND ARE WRITING A SPECIFICATION. THIS PROJECT IS AT LEAST 4 MONTHS BEHIND SCHEDULE.	106.0		21.4	JUL 80	JUN 81
6 80 8026	APPLICATION OF SYNTHETIC QUENCHANTS TO GUN TUBES THIS PROJECT HAS JUST FUNDED. NO STATUS REPORT IS REQUIRED.	143.0				
6 80 8030	MANUFACTURING GUIDE FOR ELASTOMERIC SEALS THIS PROJECT HAS JUST FUNDED. NO STATUS REPORT IS REQUIRED.	100.0				
6 80 8034	MANUFACTURING SHOP FLOOR FEEDBACK SYSTEM (CAM) THIS PROJECT HAS JUST FUNDED. NO STATUS REPORT IS REQUIRED.	84.0				
6 80 8035	COATING TUBE SUPPORT SLEEVES WITH BEARING MATERIALS THIS PROJECT HAS JUST FUNDED. NO STATUS REPORT IS REQUIRED.	140.0				
6 78 8043	IMPROVED MACHINING PROCEDURES FOR DOVETAILS THE MACHINE SPECIFICATION FOR A BED TYPE DUPLEX MILLING MACHINE WITH TRAVELING COLUMNS HAS BEEN COMPLETED. IT IS BEING REVIEWED BY INDUSTRIAL ENGINEERING PRIOR TO PROCUREMENT ACTION.	100.0		75.0	JUN 79	FEB 80
6 78 8045	IMPROVED TUBE STRAIGHTENING ELECTRONIC EQUIPMENT HAS BEEN PURCHASED.	125.0	30.0	28.5	MAR 80	AUG 80
6 78 8047	PASS THRU STEADY RESTS FOR TUBE TURNING ENG REQUIREMENTS FOR ESTAB HYDRAULIC PRESSURE TO SAFELY SUPPORT AND RETAIN VARIOUS GUN TUBES HAVE BEEN COMPLETED. SURVEY TO DETERMINE AVAILABILITY OF COMMERCIAL SYSTEMS HAS BEEN COMPLETED. ENG STUDY HAS PRODUCED A VARIETY OF CONCEPTS FOR EQUIP DESIGN.	139.0	15.0	52.3	SEP 80	AUG 80
6 80 8047	PASS THRU STEADY RESTS FOR TUBE TURNING THIS PROJECT HAS JUST FUNDED. NO STATUS REPORT IS REQUIRED.	269.0				
6 78 8048	IMPROV INSPECTION TECH F/INOTS + PREFORMS F/ARTARY FORGING EVALUATING CONTRACTS HAVE BEEN AWARDED TO 3 CONTRACTORS. THE RESULTS FROM THESE CONTRACTS ARE SCHEDULED TO BE SUBMITTED 15 JAN 80. UPON RECEIPT OF THE EVALUATION RESULTS, A RFQ WILL BE ISSUED.	113.0	1.5	54.1	SEP 80	APH 81

S U B P A R Y P R O J E C T S T A T U S R E P O R T
2ND SEMIANNUAL SUBMISSION CY 79 RCS DRCHT-301

PROJ NO.	TITLE + STATUS	AUTHOR- RIZED (\$000)	CONTRACT VALUES (\$000)	EXPENDED		PRESENT	
				LABOUR AND MATERIAL (\$000)	PROJECTED COMPLETE DATE	PROJECTED COMPLETE DATE	PROJECTED COMPLETE DATE
6 78 8049	MANUFACTURING PROCESSES ENERGY CONSERVATION PROGRAM AN ENERGY AUDIT HAS BEEN COMPLETED ON THREE RIFLING MACHINES AND APPROX 25% OF THE MACHINERY ENGAGED IN MFG OPNS. A PROPOSAL FOR IMPROVING THE EFFICIENT USE OF ENERGY IN ROTARY FORGING OF GUN BARRELS HAS REVIEWED AND FAVORABLY VIEWED.	104.0	1.0	22.6	DEC 79	SEP 80	SEP 80
6 80 8054	OPTICAL SCRATCH AND DIG STANDARDS FOR FIRE CONTROL SYSTEMS THIS PROJECT WAS JUST FUNDED. NO STATUS REPORT IS REQUIRED.	185.0					
6 80 8057	DUAL RIFLING BROACH REMOVAL SYSTEM THIS PROJECT WAS JUST FUNDED. NO STATUS REPORT IS REQUIRED.	215.0					
6 80 8059	SALVAGE OF CANNON COMPONENTS BY ELECTRODEPOSITION THIS PROJECT WAS JUST FUNDED. NO STATUS REPORT IS REQUIRED.	152.0					
6 80 8060	IMPROVED MFG PROCESSES FOR FINAL INSPECTION OF CANNON TUBES THIS PROJECT WAS JUST FUNDED. NO STATUS REPORT IS REQUIRED.	268.0					
6 79 8104	IMPROVED BREACH BLOCK MANUFACTURING BREACH BLOCK DRAWINGS AND MFG PRODUCTION ROUTE SHEETS WERE STUDIED TO ASSESS EACH MACHINING OPERATION THAT WILL BE PERFORMED BY THE FLEXIBLE MACHINING SYSTEM.	100.0	1.3	JAN 81	JAN 81	JAN 81	JAN 81
6 80 8105	ESTABLISH RUGH THREAD BLANKS, 8-INCH #201 RUSHING THIS PROJECT WAS JUST FUNDED. NO STATUS REPORT IS REQUIRED.	88.0					
6 80 8106	LARGE CALIBER POWDER CHAMBER BORING THIS PROJECT WAS JUST FUNDED. NO STATUS REPORT IS REQUIRED.	59.0					
6 79 8107	CREEP FEED CRUSH FURN GRINDING TEST PART HAS BEEN SELECTED. SCOPE OF WORK FOR CONTRACT HAS BEEN PREPARED.	82.0	36.3	MAY 80	SEP 80	SEP 80	SEP 80
6 80 8107	CREEP FEED CRUSH FURN GRINDING THIS PROJECT WAS JUST FUNDED. NO STATUS REPORT IS REQUIRED.	388.0					
6 80 8208	MATERIAL HANDLING THIS PROJECT WAS JUST FUNDED. NO STATUS REPORT IS REQUIRED.	113.0					
6 80 8301	HOLLOW CYLINDER CUT OFF MACHINE THIS PROJECT WAS JUST FUNDED. NO STATUS REPORT IS REQUIRED.	69.0					
6 80 8342	KEYWAY MILLING MACHINE THIS PROJECT WAS JUST FUNDED. NO STATUS REPORT IS REQUIRED.	242.0					

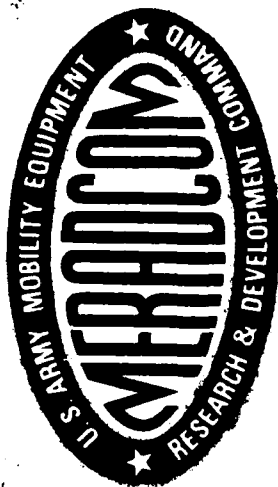
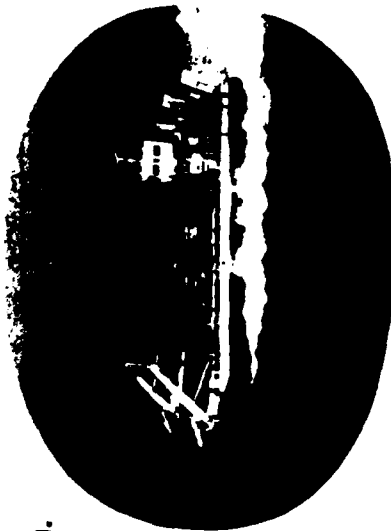

Fort Belvoir, Va.

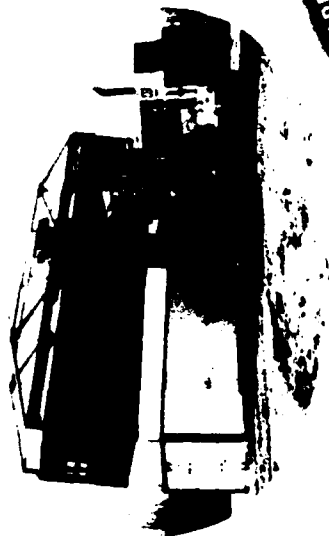

PRECEDING PAGE BLANK-NOT FILLED

MOBILITY EQUIPMENT RESEARCH AND DEVELOPMENT COMMAND
CURRENT FUNDING STATUS, 2ND CY79

FISCAL YEAR	NO. OF PROJECTS	AUTHORIZED FUNDS (\$)	CONTRACT FUNDS ALLOCATED (\$)	CONTRACT FUNDS EXPENDED (\$)	IN-HOUSE FUNDS REMAINING (\$)	IN-HOUSE FUNDS EXPENDED (\$)
77	1	750,000	742,000	700,000 (94%)	8,000	0 (0%)
78	5	1,368,000	1,096,600	830,600 (75%)	271,400	268,400 (98%)
79	9	2,866,000	2,272,500	537,500 (23%)	593,500	107,600 (18%)
80	6	1,369,000	0	0 (0%)	1,369,000	100,000 (7%)
81	0	0	0	0 (0%)	0	0 (0%)
82	0	0	0	0 (0%)	0	0 (0%)
TOTAL	21	6,353,000	4,111,100	2,068,100 (50%)	2,241,900	476,000 (21%)

AUTHORIZED FUNDING CONTRACT ALLOCATED 65% IN-HOUSE REMAINING 35%

MANUFACTURING METHODS AND TECHNOLOGY PROGRAM
 S U M M A R Y P R O J E C T S T A T U S R E P O R T
 2ND SEMIANNUAL SUBMISSION CY 79 RCS DRCHT-301

PROJ NO.	TITLE + STATUS	AUTHORIZED (8000)	CONTRACT VALUES	EXPANDED LABOR AND MATERIAL (8000)	ORIGINAL PROJECTED COMPLETE DATE	PRESENT PROJECTED COMPLETE DATE
E 78 3532	MOLTEN SALT LI/LCL BATTERY A NEW 9/CELL BATTERY DESIGNED FOR MODULE INSULATING ENCLOSURE. HARDWARE IMPROVEMENTS INCL INCREASED STIFFNESS OF CELL TRAY TO PREVENT CELL SWELLING, ALSO HIGHLY FLEXIBLE INTERCELL CONNECTIONS TO ALLEVIATE STRESSES ON THE CELL FEEDTHROUGHS.	120.0	105.0	14.0	DEC 78	JUL 80
E 79 3532	MOLTEN SALT LI/LCL BATTERY BATTERY WILL NOW BE CONSTRUCTED WITH FELT RATHER THAN FABRIC ON SEPARATORS IN THE CELLS, ON FELT WITH GREATLY IMPROVED PHYS PRUPS AND LOWER MFG COSTS NOW POSSIBLE. BATTERY DESIGN WILL ALSO INCLUDE HARDWARE IMPROVEMENTS NOW UNDER TEST IN THE MODULE.	295.0	280.0		AUG 80	APR 81
E 79 3592	IMPROVED GRAPHITE REINFORCEMENT-PHASE 3 A CONTRACT WAS NEGOTIATED AND PLACED THAT WILL CONTINUE THE WORK PERFORMED IN PHASE 1. OBJECTIVE OF PHASE 2 WILL BE TO DEVELOP A GRAPHITE FIBER WITH TENSILE STRENGTH OF 750,000 PSI. INDUCTION HEATING CAN ACHIEVE ECONOMIES OVER PLASMA ARC HEATING.	282.0	247.5	3.1	SEP 80	SEP 80
E 78 3604	SOLID STATE POWER SWITCH DELTA ELECTRONICS DELAYED THE WORK BECAUSE OF FINANCIAL PROBLEMS. DELTA IS PACKAGING TRANSISTOR CHIPS AND CONTROL CIRCUITRY ON A COMMON HEAT SINK. PRE-ENGINEERING SAMPLES WERE BUILT AND TESTED. DELAY WILL NOT AFFECT COST OF THE FIXED-PRICE CONTRACT.	350.0	295.0	55.0	JUN 80	SEP 80
E 79 3604	SOLID STATE POWER SWITCH FOLLOW-ON TO ABOVE. SEE STATUS ABOVE.	85.0	54.0	21.0	JUN 81	SEP 80
E 79 3605	TRANSCALENT-HIGH POWER-TRANSISTOR FOLLOW ON TO ABOVE. RCA WORKED OUT A METHOD FOR PLATING AND ETCHING AN INTERDIGITATED METALLIZATION ONTO A SILICON TRANSDUCER WAFER. BALLAST RESISTORS OF SIMILAR CONFIGURATION WERE THEN JOINED TO IT. ENG + CONFIRMATORY SAMPLES WERE DELIVERED.	453.0	374.0	45.0	MAR 82	SEP 81
E 80 3605	TRANSCALENT (HIGH POWER) TRANSISTOR FOLLOW ON TO ABOVE. FUNDS WERE RECEIVED 31 DEC AND NOTHING WAS DONE. FY80 EFFORT IS INTENDED TO COMPLETE THIS THREE YEAR EFFORT WITH TEST AND APPLICATION OF THE TRANSISTORS.	61.0			MAR 82	MAR 82
E 78 3606	250 AMP TRANSCALENT (HIGH POWER) RECTIFIER RCA IS DEVELOPING PROCESS CONTROLS FOR APPLYING OR ETCHING A VARIABLE THICKNESS METALLIZATION TO A DIODE WAFER FOR UNIFORM CURRENT DISTRIBUTION.	360.0	305.0	55.0	JUN 80	JUN 81
E 79 3606	250 AMP TRANSCALENT (HIGH POWER) RECTIFIERS ENGINEERING AND CONFIRMATORY SAMPLES WERE DELIVERED, AND SOME ARE BEING EVALUATED BY POTENTIAL USERS.	85.0	55.0	25.0	JUN 81	JUL 81

MANUFACTURING METHODS AND TECHNOLOGY PROGRAM
 S U M M A R Y P H O J E C T S T A T U S R E P O R T
 2ND SEMIANNUAL SUBMISSION CY 79 MCS DRCHT-301

PROJ NO.	TITLE + STATUS	AUTHORIZED (\$000)	CONTRACT VALUES (\$000)	EXPANDED LABOR AND MATERIAL (\$000)	ORIGINAL PROJECTED COMPLETE DATE	PRESENT PROJECTED COMPLETE DATE
E 78 3613	VEHICLE-MOUNTED ROAD MINE DETECTOR SYSTEM ANTENNAS DESIGN RECOMMENDATIONS HAVE BEEN MADE AND APPROVED. THE TECHNIQUE ASSESSMENT HAS BEEN COMPLETED AND THE REPORT HAS BEEN SUBMITTED FOR REVIEW.	195.0	163.0	30.0	JUN 80	JUN 80
E 79 3613	VEHICLE-MOUNTED ROAD MINE DETECTOR SYSTEM ANTENNAS TECHNIQUE ASSESSMENT AND EVALUATION HAS BEEN COMPLETED. A REPORT ON THE ASSESSMENT IS BEING PREPARED. PILOT PRODUCTION OF ANTENNAS HAS BEEN INITIATED.	163.0	99.0		JUN 80	JUN 80
E 79 3708	COATED FABRIC COLLAPSIBLE FUEL TANK-CIRCULAR SEAM WEAVING CONTRACT PACKAGE PREPARED. NEGOTIATIONS IN PROCESS WITH CONTRACTOR IN TEXTILE INDUSTRY. AWARD ANTICIPATED FOR FEB 1980.	97.0		7.0	AUG 79	JUL 81
E 80 3708	COATED FABRIC COLLAPSIBLE FUEL TANK PROGRAM - CIRCULAR SEAM CONTRACT PACKAGE PREPARED. NEGOTIATIONS IN PROCESS WITH CONTRACTOR IN TEXTILE INDUSTRY. CONTRACT WILL BE MODIFIED TO INCLUDE PERFECTION OF AUTOMATED COATING OF SEAMLESS TUBES. AWARD ANTICIPATED FOR SEPT 1980.	150.0			SEP 81	SEP 81
E 79 3709	CONTINUOUS LENGTH FUEL HOSE CONTRACT NEGOTIATIONS ARE PROCEEDING.	245.0		6.5	SEP 81	SEP 81
E 80 3709	CONTINUOUS LENGTH FUEL HOSE THIS PROJECT WAS JUST FUNDED. NO STATUS REPORT IS REQUIRED.	329.0				
E 80 3716	PRODUCTION OF KOCITE (R) DERIVED ELECTRODES FOR FUEL CELLS THIS PROJECT WAS JUST FUNDED. NO STATUS REPORT IS REQUIRED.	238.0				
E 78 3717	HIGH TEMPERATURE TURBINE NOZZLE FOR 10 KW POWER UNIT THE FOUR SUPPLIERS SUBMITTED SAMPLE VANES AND TEST BARS. ALL SAMPLES PASSED VISUAL INSPECTION, BUT SOME PROBLEMS IN ACHIEVING REQUIRED SURFACE FINISH AND DIMENSIONAL TOLERANCES WERE EXPERIENCED. TEST PREPARATIONS HAVE BEEN COMPLETED.	343.0	228.6	114.4	SEP 79	SEP 80
E 80 3717	HIGH TEMPERATURE TURBINE NOZZLE FOR 10 KW POWER UNIT THIS PROJECT WAS JUST FUNDED. NO STATUS REPORT IS REQUIRED.	400.0				
E 79 3743	COMPOSITE SPUN MATERIAL LAUNCHING BEAM FOR BRIDGES THE CONTRACT HAS BEEN PLACED.	1,161.0	1,161.0		SEP 80	MAY 81
E 80 3747	LIGHTER, LACV-30, SKIRT AND FINGER COMPONENTS THE INITIAL ANALYSIS OF THE PROGRAM HAS BEEN COMPLETED.	191.0		100.0	NOV 80	NOV 80
E 77 3749	HYDRAULIC ROTOR ACTUATORS TEN UNITS HAVE BEEN FABRICATED, BENCH TESTED. VEHICLE TESTS HAVE BEEN INITIATED.	750.0	742.0		MAY 79	MAR 80



**COMMUNICATIONS R&D COMMAND
(CORADCOM)**

COMMUNICATIONS R + D COMMAND
CURRENT FUNDING STATUS, 2ND CY79

FISCAL YEAR	NO. OF PROJECTS	AUTHORIZED FUNDS (\$)	* ALLOCATED (\$)	* CONTRACT FUNDING EXPENDED (\$)	* REMAINING (\$)	* INHOUSE FUNDING EXPENDED (\$)
76	3	1,474,300	1,353,200	1,307,800 (96%)	121,100	120,000 (99%)
77	0	0	0	0 (0%)	0	0 (0%)
77	1	448,800	398,800	398,800 (100%)	50,000	50,000 (100%)
78	2	816,500	745,900	385,700 (51%)	70,600	69,600 (98%)
79	2	1,110,000	545,000	79,600 (14%)	565,000	1,300 (0%)
80	2	594,000	0	0 (0%)	594,000	0 (0%)
81	0	0	0	0 (0%)	0	0 (0%)
82	0	0	0	0 (0%)	0	0 (0%)
TOTAL	10	4,443,600	3,042,900	2,171,900 (71%)	1,400,700	240,900 (17%)

AUTHORIZED FUNDING CONTRACT ALLOCATED 68% INHOUSE REMAINING 31%

S U B M A N Y P H O J E C T S T A T U S R E P O R T
 MANUFACTURING METHODS AND TECHNOLOGY PROGRAM
 2ND SEMIANNUAL SUBMISSION CY 79 RCS DRCMF-301

PROJ NO.	TITLE + STATUS	AUTHORIZED (\$000)	CONTRACT VALUES (\$000)	EXPANDED LABOR AND MATERIAL (\$000)	ORIGINAL PROJECTED COMPLETE DATE	PRESENT PROJECTED COMPLETE DATE
F 80 5032	CONNECTOR TERMINATED STRIPE GEOMETRY INJECTION LASERS THIS PROJECT WAS JUST FUNDED. NO STATUS REPORT IS REQUIRED.	400.0				
F 80 3036	CAD/CAM OF SPECIAL ELECTRONIC CIRCUITS THIS PROJECT WAS JUST FUNDED. NO STATUS REPORT IS REQUIRED.	194.0				
2 78 9773	COMPUTER AIDED F/PREP OF AUTO ANALOG CIRCUIT PROD TEST PROG INSTALLATION OF THE PROGRAMMING STATION AT THE CONTRACTOR'S PLANT WAS COMPLETED. WORK WAS COMPLETED ON COMPONENT NETWORKS FOR ATLAS CODING AND COMPILATION OF ATLAS PROGRAMS/GENERATION OF INTERACTIVE SPECS, INTERFACE DEVICE DESIGN, INPUT + OUTPUT CODE.	500.0	453.4	45.6	NOV 79	SEP 80
2 76 9776	FAB METHODS FOR LOW COST HYBRID SILICON PHOTODETECTOR MODULE RCA WUREC DEMONSTRATED ITS SEMI-AUTOMATIC PILOT LINE ON 27 NOV 79. THE UNIT ALLIGNS FIBER OPTICS TO THE PHOTODETECTOR. ONLY 1 DETECTOR FIRM SAW THE DEMO. 17 FIRMS WERE INVITED BUT ONLY 5 ATTENDED. PHOTODETECTOR MODULE FOR GVS-5 LASER RANGE FINDER.	446.5	411.4	35.0	AUG 78	FEB 80
2 76 9778	LONG LIFE LIGHT EMITTER FOR FIBER OPTICS SEE INDIVIDUAL SUBTASKS FOR STATUS.	437.6	392.8	45.0	AUG 78	MAY 81
2 76 9778 A	LONG LIFE LIGHT EMITTER FOR FIBER OPTICS LASER DIODE LAD MADE SINGLE STRIPE INJECTION LASER DIODES FOR FIBER OPTIC COMMUNICATIONS. THEY FAILED BURN-IN TESTS. REPLACEMENTS ARE IN PROCESS FOR RE-TESTING. LIQUID PHASE EPITAXIAL SYNTHESIS, PHOTOLITHOGRAPHY AND CHEMICAL ETCHING ARE UTILIZED.	437.6	193.8	45.0		MAY 81
2 76 9778 B	LONG LIFE LIGHT EMITTER FOR FIBER OPTICS LASER DIODE LAB ESTABLISHED A SELECTIVE DIFFUSION PROCESS USING A FINED LASER EMITTING SPOT. THE CHIP IS SOLDERED TO THE HEADER WITH A CREAM SOLDER FOR A LOW RESISTANCE, LOW LOSS CONTACT	437.6	194.9	45.0		MAY 81
2 76 9781	THIN FILM TRANSISTOR ADDRESSED DISPLAY SEE SUBTASKS A AND B BELOW.	590.0	549.0	40.0	AUG 78	MAY 80
2 76 9781 A	THIN FILM TRANSISTOR ADDRESSED DISPLAY TESTINGHOUSE EXPENDED ALL CONTRACT FUNDS WITHOUT ACHIEVING ITS GOALS. EIGHT TFT DISPLAY PANELS WERE FABRICATED, BUT NONE OPERATE PERFECTLY. ALL WORK WAS HALTED EXCEPT FOR WRITING THE FINAL REPORT. IT WILL DETAIL PROGRESS AND NOTE PITFALLS TO AVOID.	345.0	310.0	35.0		MAY 80
2 76 9781 B	THIN FILM TRANSISTOR ADDRESSED DISPLAY A FOLLOW-ON CONTRACT AT TESTINGHOUSE PROVIDED NEW METALLIZATION METHODS AND NEW MASKS DESIGNS TO REDUCE PROCESS STEPS AND TIME. ALL FUNDS WERE EXHAUSTED AND WORK STOPPED EXCEPT FOR COMPLETION OF FINAL REPORT.	245.0	239.0	6.0		MAY 80

MANUFACTURING METHODS AND TECHNOLOGY PROGRAM
 S U M M A R Y P R O J E C T S T A T U S R E P O R T
 2ND SEMIANNUAL SUBMISSION CY 79 RCS DRCHT-301

PROJ NO.	TITLE + STATUS	AUTHOR- RIZED (\$000)	CONTRACT VALUES (\$000)	EXPENDED ORIGINAL LABOR AND MATERIAL (\$000)	ORIGINAL PROJECTED COMPLETE DATE	PRESENT PROJECTED COMPLETE DATE
2 77 9835	INT CONTL CRCT FOR THIN FILM TRANSISTR DISPLAY AER/JET HAD PROBLEMS MAKING TFT EL PANEL DISPLAYS. FUNDS WERE DEPLETED WITHOUT ACHIEVING GOALS. WORK TO ETCH THIN FILM CIRCUITS WITH 0.1 MIL TOLERANCE ON 4 INCH MASKS WILL CONTINUE ON FOLLOW-ON 279 9835. A SMALLER DISPLAY PACKAGE WILL RESULT.	448.0	398.8	50.0	MAR 79	AUG 81
F 79 9835	INTEGRATED THIN FILM TRANSISTOR DISPLAY AER/JET FOLLOW-ON TO 2 77 9835. A MODIFICATION OF THE TFT EL ARRAY WILL ALLOW USE OF AVAILABLE ICS FOR THE DISPLAY PERIPHERAL SCANNING CIRCUITRY. WORK WILL ESTABLISH COMPATIBILITY AMONG 23 THIN FILM LAYERS, INSULATING MATERIALS AND PROCESSES.	600.0	545.0		AUG 81	AUG 81
2 78 9898	RUGGEDIZED TACTICAL FIBER OPTIC CABLES ITT ELECTRO-OPTICS INSTALLED NEW HIGH SPEED OPTICAL CABLE STRANDER-SERVING LINE AND POLYURETHANE JACKET EXTRUSION LINE WITH FULL AUTOMATIC CONTROL. IT FABRICATES RUGGEDIZED FIBER OPTIC CABLE PROBLEMS: EACH FIBER IS OPT TESTER PRIOR TO STRANDING.	316.5	292.5	24.0	NOV 79	JUL 81
F 79 9938	THREE COLOR LIGHT EMITTING DIODE DISPLAY UNIT A PROCUREMENT PACKAGE HAS BEEN SUBMITTED. BIDS ARE DUE ON 21 JAN 80. THIS PROJECT HAS NOT BEEN STARTED AND 13 MONTHS OF SLIPPAGE ARE ALREADY PROJECTED. PROBLEMS WITH THE PACING ROD ARE CITED AS THE REASON FOR THE SLIPPAGE.	510.0		1.3	SEP 81	FAM 82

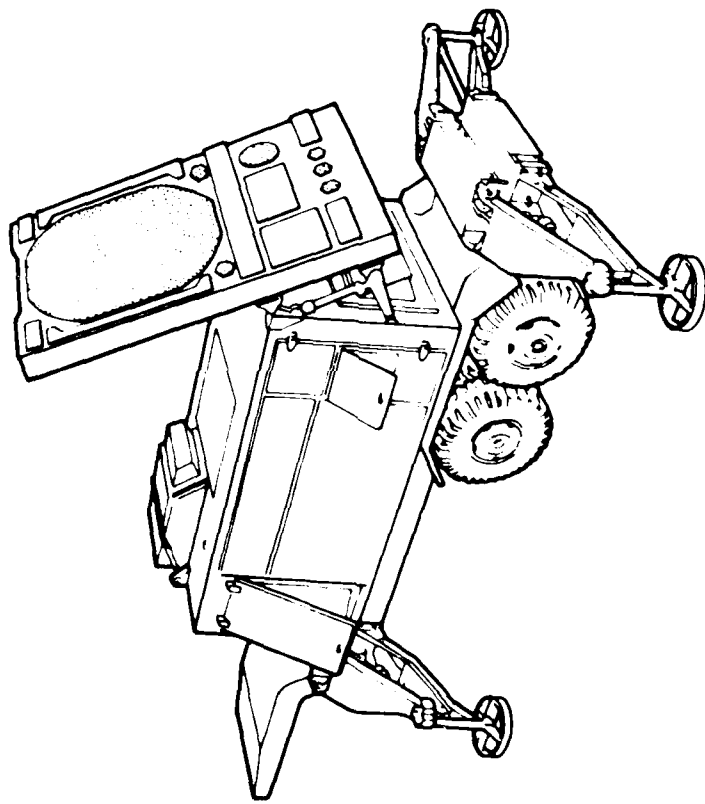

**ELECTRONICS R&D COMMAND
(ERADCOM)**

ELECTRONICS H + D COMMAND

CURRENT FUNDING STATUS, 2ND CY79

FISCAL YEAR	NO. OF PROJECTS	AUTHORIZED FUNDS (\$)	C O N T R A C T A L L O C A T E D (\$)	F U N D I N G E X P E N D E D (\$)	I N H O U S E R E M A I N I N G (\$)	F U N D I N G E X P E N D E D (\$)
76	7	2,601,000	2,342,200	2,215,400 (94%)	258,800	241,700 (93%)
77	0	0	0	0 (0%)	0	0 (0%)
77	14	10,294,400	8,708,200	7,275,600 (83%)	1,586,200	885,600 (55%)
78	6	3,482,800	2,828,200	1,503,300 (53%)	654,600	155,500 (23%)
79	10	4,753,400	3,003,300	311,100 (10%)	1,750,100	88,200 (5%)
80	11	7,016,500	0	0 (0%)	7,016,500	15,000 (0%)
81	0	0	0	0 (0%)	0	0 (0%)
82	0	0	0	0 (0%)	0	0 (0%)
TOTAL	48	28,148,100	14,881,900	11,305,400 (66%)	11,266,200	1,346,000 (12%)

AUTHORIZED FUNDING CONTRACT ALLOCATED 60% INHOUSE REMAINING 40%

MANUFACTURING METHODS AND TECHNOLOGY PROGRAM
 S U M M A R Y P R O J E C T S T A T U S R E P O R T
 2ND SEMI-ANNUAL SUBMISSION CY 79 RCS DRCHT-301

PROJ NO.	TITLE + STATUS	AUTHORIZED (\$000)	CONTRACT VALUES (\$000)	EXPENDED LABOR AND MATERIAL (\$000)	ORIGINAL PROJECTED COMPLETE DATE	PRESENT PROJECTED COMPLETE DATE
M 80 3009	10 MICRON WAVEGUIDE LASERS A CONTRACTOR WILL ESTABLISH PRODUCTION TECHNIQUES FOR FABRICATING CRITICAL PARTS OF THE LASER TO PRECISE TOLERANCES WITH A HIGH YIELD AT REDUCED COST UTILIZING MATERIALS STABLE AT ENVIRONMENTAL EXTREMES. MINIMUM RATE WILL BE 60 UNITS PER MONTH.	500.0			MAR 82	MAR 82
M 80 3010	MILLIMETER-WAVE SOURCES FOR 60, 94, AND 140 GHz PROJECT IS JOINTLY FUNDED WITH AIR FORCE. A CONTRACTOR WILL APPLY COMPUTER CONTROL TO EPITAXIAL GROWTH SYSTEM AND DEVICE PROCESSING. WILL MAKE AND TEST IMPATT DIODES FOR RADAR, TARGET DETECTION, AND HOMING. AF CONTRIBUTED \$600K.	830.0		5.0	JUL 82	JUL 82
M 80 3012	INFRA-RED SOURCE FOR ANALG-144 THE CONTRACT WAS NOT YET AWARDED. THE OBJECT IS TO ESTABLISH PRODUCTION PROCESSES FOR MACHINING THE BURON NITRIDE RADIATOR, GRINDING THE SAPPHIRE LENSE, ASSEMBLING, BURN-IN, AND TEST. APPLICATION IS AN INFRARED SOURCE.	350.0			JAN 81	LCT 81
M 80 3023	TUBULAR PLASMA PANEL A PROCEDURE PACKAGE WAS PREPARED AND WAS SENT OUT ON 13 DEC 80. BIDS ARE TO BE RECEIVED BY 31 JAN 80.	800.0			APR 82	APR 82
M 80 3026	HIGH PRESSURE OXIDE IC PROCESS A P&D PACKAGE WAS SENT TO PROCUREMENT IN NOV. AWARD SHOULD BE IN MAY. A FIRM WILL INDUSTRIALIZE THE AUTOCLAVE PROCESS FOR PRESSURE OXIDATION OF SILICON WAFERS. THIS WILL PERMIT FASTER GROWTH AT 300C LOWER TEMPERATURE AND REDUCE INTERNAL STRESS	912.5		5.0	MAY 82	MAY 82
M 80 3031	10.6 UM CO2 TEA LASERS THE CONTRACTOR WILL ESTABLISH PRODUCTION TECHNIQUES AND WILL DESIGN TOOLS TO FABRICATE CRITICAL PARTS FOR THE LASER TO TIGHT TOLERANCES AT REDUCED COST USING MATERIAL STABLE OVER ENVIRONMENTAL EXTREMES. TARGET PRODUCTION IS 60 UNITS PER MONTH MINIMUM	550.0			MAR 82	MAR 82
M 80 3501	THIRD GENERATION PHOTOCATHODE ON FIBER OPTIC FACEPLATE A CONTRACTOR WILL SET METHODS FOR HANDLING HIGH PURITY GALLIUMARSENIDE STARTING MATERIAL, FUM PHOTOCATHODE PRODUCTION, FOR FIBER OPTIC REFRACTIV INDEX CUTTING AND BONDING, FOR OPTIMIZING ANTI-REFLECTIVE COATING, AND FOR ELECTRICAL CONTACT PLATING.	830.0		5.0	MAR 82	MAR 82
M 79 3504	ADV METH F/FAHM CALCOGENIDE GL IP LENS BMS A-ORPHEUS MATERIALS INC IS ESTABLISHING CASTING PROCESSES FOR PRODUCING UNIFORM GE-AS-SE GLASS IN 10 INCH DIAMETER PLATES FOR IMPREGATED SYSTEMS. SOME MIXING CHAMBERS WERE DESIGNED AND USED. QUARTZ OVEN, REACTOR FURNACE AND GLASS WAS ORDERED.	273.5	230.0	13.2	MAY 81	JUL 81

S U M M A R Y P R O J E C T S T A T U S R E P O R T
2ND SEMIANNUAL SUBMISSION CY 79 HCS DRCDT-301

PROJ NO.	TITLE + STATUS	AUTOM- RIZED (\$000)	CONTRACT VALUES (\$000)	EXPENDED LABOR AND MATERIAL (\$000)	ORIGINAL PROJECTED COMPLETE DATE	PRESNT PROJECTED COMPLETE DATE
H 80 3510	TRANSDUCER PROCESS TECHNOLOGY FOR MW DELAY LINES A CONTRACTOR WILL ESTABLISH MANUFACTURING TECHNIQUES FOR FABRICATING HIGH QUALITY ZINC OXIDE TRANSDUCERS WITH A YIELD OF OVER 50 PERCENT. A STATEMENT OF WORK WAS PREPARED AND A LITERATURE SEARCH BEGUN.	509.0			AUG 82	AUG 82
H 78 3511	FAB OF SUBMICRON PHOTOMASKS FOR INTEGRATED CIRCUIT DEVICES HEWLETT-PACKARD IS USING SHORTER WAVELENGTH UV OPTICS + AN IMPROVED UV LIGHT SOURCE TO DEVELOP SUBMICRON GEOMETRIES FOR VERY LARGE SCALE CIRCUITRY. ON-LINE SOFTWARE PATTERN REVERSAL PROGRAM THAT ORBITATES CHEMICAL REVERSAL OF RETICLES PUT INTO USE.	385.0	58.1	20.0	SEP 81	JUN 81
H 79 3516	CRYOGENIC COOLER HYBRID MOTOR CIRCUIT AEROFLEX WILL ESTABLISH HIGH VOLUME, HIGH YIELD, LOW COST MANUFACTURING METHODS FOR PRODUCING SMALL HYBRID ELECTRONIC CIRCUITS FOR USE IN CRYOGENIC COOLERS. A PROTECTIVE COATING WILL ALLOW IMMERSION OF THE CIRCUIT IN THE LIQUID HELIUM.	175.9	147.8	5.0	JUN 81	MAR 81
H 79 5000	PRODUCTION NOT FURGING OF ALKALI HALIDE LENSES MONEYWELL WILL ESTABLISH TECHNIQUES TO MOUNT FORRE POTASSIUM BROMIDE INTO LENS ELEMENTS IN BATCHES AT LOW TEMPERATURE. MONEYWELL IS OPTIMIZING PARAMETERS TO MAXIMIZE PRODUCTION WITHOUT COMPROMISING QUALITY. WILL REPLACE ZINC SELENIDE LENSES.	594.0	544.0	22.0	SEP 81	SEP 81
H 79 5042	LARGE DIAMETER ND LITTON WILL USE THE CZUCHRALSKI METHOD FOR GROWING LARGER 50 MM DIAMETER ND:YAG BOWLES. THIS NEW PRODUCTION SIZE WILL IMPROVE LASER RND YIELD. RAW MATERIALS WERE TESTED AND FOUND ACCEPTABLE. OPTIMUM GROWTH TEMP GRADIENTS WERE DETERMINED.	350.0	303.0	5.0	JUL 81	JUL 81
H 80 9563	MINATURE HIGH VOLTAGE POWER SUPPLYS FOR NIGHT VISION GOGGLES NO PROGRESS WAS REPORTED.	535.0			JUN 82	JUN 82
H 80 9588	THIRD GENERATION LOW COST IMAGE INTENSIFIER TUBES THE CONTRACT WAS NOT YET AWARDED. A FIRM WILL DEVELOP OPTIMUM ASSEMBLY, INSPECTION AND SALVAGE METHODS FOR TGC II TUBES. VACUUM PROCESSES WILL INCLUDE PREBAKE AND ELECTRON DESORPTION OF MICROCHANNEL PLATE + PHOSPHOR SCREEN, GETTER FLASH, + SEAL.	900.0			APR 83	APR 83
2 76 9738	EPITAXIAL + METALLIZATION PROCESSES FOR GaAs IMPATT DIODES MICROWAVE ASSOCIATES IS MAKING A PILOT RUN OF GALLIUM ARSENIDE IMPATT DIODES. EARLIER SAMPLES MET THE SPECS. CONTRACT WAS EXTENDED 7 MOS. AT NO COST. AUTOMATIC CONTROLS WERE APPLIED TO THE EPITAXIAL REACTOR BUT PROBLEMS OCCURRED WITH SEQUENTIAL GROW-	248.8	248.8		JUN 77	FFH 80

MANUFACTURING METHODS AND TECHNOLOGY PROGRAM
 S U M M A R Y P R O J E C T S T A T U S R E P O R T
 2ND SEMI-ANNUAL SUBMISSION CY 79 RCS DRCHT-301

PROJ NO.	TITLE + STATUS	AUTHORIZED (\$000)	CONTRACT VALUES (\$000)	EXPENDED LABOR AND MATERIAL (\$000)	ORIGINAL PROJECTED COMPLETE DATE	PRESENT PROJECTED COMPLETE DATE
H 78 9738	PULSED GALLIUM ARSENIDE IMPATT DIODES FOLLOW-ON TO ABOVE. MICROWAVE ASSOCIATES HAD PROBLEMS WITH SEQUENTIAL GROWTH OF P-TYPE AND THEN N-TYPE EPY LAYERS IN THE SAME REACTOR. SOME DIODES WERE RUN SEQUENTIALLY IN TWO REACTORS TO MEET SAMPLE DELIVERY SCHEDULES. CONTRACT WAS EXTENDED 7 MOS.	500.0	441.2	25.0	JUN 80	OCT 80
2 76 9746	THIN FILM AL OXIDE ION BARRIERS FOR 18MM MICROCHANNEL PLATES. ITT MADE A PILOT RUN TO DEPOSIT THE ALUMINUM OXIDE FILM ON THE INPUT SURFACE OF THE MICROCHANNEL PLATE. BUT THE WAFER IMAGE TUBES USED TO TEST THE MCPs GAVE LIFE TEST PROBLEMS. ITT IS NOW ALLOWED TO USE EXISTING TUBES FOR 4,000 HOUR LIFE TEST.	480.0	432.0	45.0	JUL 79	APR 80
2 77 9751	MFG METHODS FOR FABRICATION OF YAG LASER RODS. NEW BATCH GRINDING AND POLISHING PROCESSES YIELD LASER RODS EXCEEDING SPEC SC9-507. NEW TOOLING AND PROCESSES WERE USED TO PRODUCE 150 RODS PER MONTH FOR THE MORE STRINGENT AN/GVS-5 LASER RANGEFINDER.	142.0	64.5	24.0	JAN 79	MAR 80
2 77 9754	CONTIN CYCLE PROC OF SHOCK RESISTANT QUARTZ CRYSTAL UNITS FOLLOW-ON TO 2 76 9734. DEMO IS BUILDING A PILOT LINE WITH CAPABILITY OF PRODUCING 55 HIGH SHOCK RESISTANT QUARTZ CRYSTALS A DAY. CONFIRMATORY SAMPLE FABRICATION WAS STARTED. A COST OVERRUN IS HIGHLY PROBABLE.	1,469.4	1,426.4	63.0	DEC 79	FEB 81
2 76 9766	DEPOSITION OF A HIGHVOLTAGE INSULATING LAYER FOR THICK FILM ERIE TECH WAS UNABLE TO BUILD A WORKABLE MULTIPLIER MODULE. NEW CONFIGURATION WAS ACCEPTED AND CONTRACT WILL BE MODIFIED. SUCCESSFUL SAMPLES MUST BE SUBMITTED BY DEC 80 OR CONTRACT WILL BE TERMINATED. NEW CONFIGURATION INVOLVES NO ADDED COSTS.	162.9	126.5	35.0	AUG 78	AUG 81
2 76 9767	DEPOSITION OF THICK FILM CIRCUITS FOR CRYSTAL OSCILLATORS. HAYTHEON HAD A \$97K COST OVERRUN WITHOUT ACHIEVING THE TECHNICAL GOALS. LASER TRIM, EUTECTIC DIE AND CHIP WIRE BONDING WERE USED IN THICK FILM CIRCUIT FABRICATION. CONTRACT WILL BE TERMINATED FOLLOWING APPROVAL OF THE FINAL REPORT.	392.7	360.7	31.5	AUG 78	MAY 80
2 76 9771	LOW TEMP PROCESS OF BULK SEMICONDUCTOR SWITCHES + LIMITERS. MICROWAVE ASSOCIATES PILOT RUN OF DIOD LIMITERS WAS ACCEPTABLE BUT ITS DRAFT FINAL REPORT WAS NOT. A DEMO WAS MADE IN AUG 79. SOLID STATE LIMITERS WILL HAVE 10000 HOUR LIFE AND REPLACE 300 HOUR TUBES IN HAWAII FRONT ENDS.	380.0	347.5	32.5	AUG 78	APR 80
2 76 9783	PRODUCTION OF HIGH RESISTIVITY SILICON MATERIAL. SEE SUBTASKS A AND B. WORK WAS JOINTLY FUNDED WITH THE AIR FORCE. AFML CONTRIBUTED \$457.1 AND MONITORED THE TWO CONTRACTS. WORK IS COMPLETE. TECHES PROPOSED FOLLOW-ON WORK TO AUTOMATE THE PROCESS AND REDUCE LABOR COST.	591.0	534.1	57.7	AUG 78	DEC 79

S U M M A R Y P R O J E C T S T A T U S R E P O R T
 2ND SEMI-ANNUAL SUBMISSION CY 79 KCS DRCONT-301

PROJ NO.	TITLE + STATUS	AUTOM- RIZED (8000)	CONTRACT VALUES (8000)	EXPENDED LABOR AND MATERIAL (\$000)	ORIGINAL PROJECTED COMPLETE DATE	PRESENT PROJECTED COMPLETE DATE
2 76 9783 A	PRODUCTION OF HIGH RESISTIVITY SILICON MATERIAL HUGHES DEMONSTRATED ITS ZONE REFINING EQUIPMENT FOR PURIFYING HIGH RESISTIVITY SILICON FOR DETECTORS, COST DROPPED FROM \$30 PER GRAM TO \$10. BUT HACKER OF GERMANY CUT THEIR PRICE TO \$4 TO SOME CUSTOMERS BUT \$30 TO THE US GOVT.	506.4	457.1	49.3		DEC 79
2 76 9783 R	PRODUCTION OF HIGH RESISTIVITY SILICON MATERIAL UNIV. OF DAYTON RESEARCH INST. IMPROVED MEASURING TECHNIQUES FOR CHARACTERIZING HIGH RESISTIVITY (20000 OHM-CM) MATERIAL. CONTRACT IS COMPLETED.	85.4	77.0	8.4		DEC 79
M 79 9783	PRODUCTION OF HIGH RESISTIVITY SILICON MATERIAL ***** DELINQUENT STATUS REPORT *****	600.0	533.0	10.0		
2 76 9788	FAB OF LOW VOLTAGE START SEALED BEAM ARC LAMPS. ***** DELINQUENT STATUS REPORT *****	324.0	290.6	40.0	AUG 78	
2 77 9792	POW OF FUNNELLED MCPS WITH HIGH SECONDARY EMITTING COATING GALILEO MADE GOOD PROGRESS TOWARD REDUCING FIBER SIZE AND CHANNEL SPACING, FUNNELING FOR GREATER ELECTRON INPUT, AND DEPOSITING HIGH SECONDARY ELECTRON EMISSION COATING, BUT ALUMINUM OXIDE ION BARRIER FILM SOMETIMES CRACKS, NO-COST TIME EXTENSION IS OK.	600.0	471.7	128.3	MAR 80	JAN 81
M 78 9793	PRODUCTION OF INTAGLIATED FIBER OPTIC PHOSPHOR SCREEN ITT (GEOD) ESTABLISHED METHODS TO ETCH OUT CURES OF OPTIC FIBERS. METALIZE THE WALLS AND DEPOSIT PHOSPHOR TO COMPLETELY FILL ETCH PITS. ALL EXPERIMENTAL SAMPLES WERE ACCEPTED AND THREE OF THEM ARE BEING ASSEMBLED INTO TUBES FOR COMPATIBILITY TESTS.	200.0	177.1	24.0	DEC 79	APR 80
2 77 9805	AUTO MICROCIRCUIT BRIDGE POW MEASURE OF QUARTZ CRYSTALS HUGHES IS DEVELOPING AN ADVANCED SYSTEM FOR PRODUCTION TESTING OF QUARTZ CRYSTALS. THE CRYSTAL GYM WAS TESTED AND MET ALL SPECS. COMPUTER INTERFACES ARE BEING BREADBOARDED + SOFTWARE IS BEING WRITTEN. TECHNIQUES WILL BE USED ON MIL-C-309A.	680.0	580.0	75.0	JAN 79	JUL 80
1 79 9805	QUARTZ CRYSTAL PARAMETER TESTING DID REEVALUATION DELAYED SOLE SOURCE CONTRACT AWARD. PROJECT IS A FOLLOW-ON TO 277 9805. CONTRACTOR WILL BUILD MULTICRYSTAL TEMP CHAMBERS FOR AUTOMATICALLY ACQUIRING FREQ/TEMP + AGING DATA. WILL RAISE TEST CAPACITY FROM 25 TO 200 CRYSTALS/DAY.	400.0			JUN 80	NOV 81
1 79 9807	PROCESSING HIGH STABILITY QUARTZ CRYSTAL UNIT PHASE III. FOLLOW-ON TO 276 9754 + 277 9754. GEND. A GOCC FACILITY OF JOE, WILL EXTEND PILOT LINE CAPABILITY TO INCLUDE HIGH STABILITY QUARTZ CRYSTALS. DOE PROGRAM COST ESTIMATE WAS \$750K HIGH. WORK START IS AWAITING RECEIPT OF REVISED QUOTATION.	760.0	702.0		MAR 81	SEP 81

S U M M A R Y P R O J E C T S T A T U S R E P O R T
2ND SEMI ANNUAL SUBMISSION CY 79 HCS DRCMT-301

MANUFACTURING METHODS AND TECHNOLOGY PROGRAM

PROJ NO.	TITLE + STATUS	AUTOMATED RIZED (\$000)	CONTRACT VALUES (\$000)	EXPENDED LABOR AND MATERIAL (\$000)	ORIGINAL PROJECTED COMPLETE DATE	PRESENT PROJECTED COMPLETE DATE
2 77 9808	AUTO IMPROCESS EVAL OF THICK FILM PRINT + HYBRID CKT ASSY RCA DEVELOPED A RETURN BEAM VIDICON CAMERA-COMPUTER COMPARISON SYSTEM FOR AUTOMATIC HYBRID INSPECTION, A "TESTING" SYSTEM SOFTWARE FEATURE WAS USED TO WRITE AND STORE INSPECTION CONDITIONS. GOVT AUTHORIZED TWO COST INCREASES TO COMPLETE THE WORK.	576.3	531.3	43.0	AUG 78	MAY 80
2 77 9809	MEAS TECHNIQ FOR CHEMICALS IN MFG PROC FOR SOLID ST MICROWAVE MICROWAVE ASSOCIATED HAS RESUMED TRANSMITTING DATA, ADDITIONAL COST OVER-RUN MAY BE EXPERIENCED.	651.6	644.6	7.0	NOV 78	DEC 80
2 77 9812	SPLIT CYCLE STIRLING COOLER MARTIN MARIETTA COMPLETED 6 CONFIRMATORY SAMPLE COOLERS WHICH PASSED ALL PERFORMANCE AND ENVIRONMENTAL TESTS. RELIABILITY TESTS ARE IN PROCESS + COMPLETED 900 HOURS. REVISION B OF SPEC MWT-779812 WAS DEVELOPED AND APPROVED, FOR TAS-4E5 GLDS.	795.0	439.9	65.0	JAN 80	JUN 80
2 77 9813	RUGGEDIZED LOW COST QUADRIANT DETECTOR FOR CLGP. TI CORRECTED PROBLEMS IN WAFER DIFFUSION LINE THAT HAD FORCED A SHUT DOWN FOR CLEANING. THE LINE IS NOW OPERATIONAL PRODUCING QUADRIANT DETECTORS FOR ANOTHER PROGRAM AT A HIGH YIELD. THE CONTRACT WAS EXTENDED 4 MONTHS. IS FOR COPPERHEAD DETECTORS.	375.0	159.0	40.0	JAN 80	JUN 81
2 77 9827	PROCESSING XP ARMOR FOR RADAR HARDENING APPLICATIONS CONTRACTOR RESUMED WORK IN OCT 79 AFTER CONTRACT RENEGOTIATED. THE NUMBER OF SAMPLES REDUCED FROM 20 TO 8. CONTRACTOR MOLDED 24 X 34 INCH PANELS IN BOTH 0.375 AND 1 INCH THICKNESSES. THEY WILL BE CUT TO SIZE AND SHIPPED FOR TESTING.	588.0	360.9	227.1	JUL 79	DEC 80
2 77 9834	FABRICATION- SERIES TRANSDUCER ACOUSTIC DELAY LINES TESTINGHOUSE CORRECTED WAFER BREAKAGE BY SCRIBING, AND HIGH RESISTIVITY CAUSED BY POLYIMIDE SUBSTITUTION. POUR 2ND YIELD (LESS THAN 25 PERCENT) CAUSED 3 MONTHS SLIPPAGE. METAL MASKS USED TO OBTAIN TRANSDUCERS WERE RECEIVED.	270.6	227.0	43.6	MAR 79	JUN 80
H 79 9838	MINIATURE CATHODE RAY TUBES NO PROGRESS WAS REPORTED ON THIS PROJECT. THE 1006 INITIATING THIS PROJECT WAS DATED 21 MAR 79. IT SEEMS THAT SOME PROGRESS COULD HAVE BEEN REPORTED FROM 10 MONTHS OF EFFORT.	300.0		8.0	AUG 81	AUG 81
H 78 9841	ZINC SELENIDE WINDOWS AND OPTICAL ELEMENTS RAYTHEON MADE PILOT PRODUCTION RUN TO DEMONSTRATE A RATE OF 481 ZINC SELENIDE LENS PLANKS PER MONTH. CHEMICAL VAPOR DEPOSITION WITH AUTOMATIC ZINC WIRE FEED WAS USED. IMPROVED STRENGTH CAME FROM SMALLER GRAIN SIZE. OPTICAL QUALITY EXCEEDS THE SPEC.	156.4	140.4	15.0	OFC 79	JAN 80

S U M M A R Y P R O J E C T S T A T U S R E P O R T
 2ND SEMI-ANNUAL SUBMISSION CY 79 RCS DRGHT-301

MANUFACTURING METHODS AND TECHNOLOGY PROGRAM

PROJ NO.	TITLE + STATUS	AUTHORIZED (\$000)	CONTRACT VALUES (\$000)	EXPENDED LABOR AND MATERIAL (\$000)	ORIGINAL PROJECTED COMPLETE DATE	PRESENT PROJECTED COMPLETE DATE
2 77 9842	THIRD GENERATION .9 MICRON PHOTOCATHODE SEE SUBTASKS A AND B.	1,893.0	1,771.1	0.8	DEC 79	FEB 80
2 77 9842 A	VARIAN WORK VARIAN USE COMPLETED ALL REQUIRED SAMPLES. THEY MET ALL REQUIREMENTS OF THE 0.9 MICRON PHOTOCATHODE SPECIFICATION. VARIAN USED THE PUSH-PULL EPITAXIAL MULTI-GROWTH SYSTEM AND ILLUSTRATED IT IN A VIDEO TAPE.	1,893.0	963.0	0.8	DEC 79	OCT 79
2 77 9842 B	ITT WORK ITT MADE 15 SAMPLE PHOTOCATHODES USING LIQUID PHASE EPITAXY AND PREPARED A PRELIMINARY TEST REPORT. THE SAMPLE WAS ACCEPTABLE. ITT IS MAKING AND TESTING THE 30 REQUIRED PILOT RUN SAMPLES AND IS 4 MONTHS LATE.	1,893.0	808.1	0.8	DEC 79	FEB 80
M 79 9844	CHS CIRCUITS USING SILICON ON SAPPHIRE -SUS-TECHNOLOGY THERE WAS NO RESPONSE TO A RFQ FOR A CONTRACT TO DEFINE RIBBON SAPPHIRE GROWTH. PROJECT WAS REDIRECTED TOWARD PROBLEMS IN SILICON-SAPPHIRE TECHNOLOGY. P-16 REVISION IS NEEDED. WILL STRESS EPITAXIAL FILM GROWTH AND CMOS-SUS CIRCUIT FABRICATION.	700.0		11.0	NOV 81	JUN 82
2 77 9845	NUMERICALLY CONTROLLED OPTICAL FABRICATION HONEYWELL IS MAKING VACUUM CHUCKS TO MOLD HALF FINISHED LENSES DURING ASPHERIC TURNING. THE MOUNT FOR DIAMOND TURNING THE FOUR ALUMINUM MIRRORS IS COMPLETED. SOFTWARE FOR COMPUTER GENERATED MOLOGRAMS IN PROCESS. \$2 + SAVING PREDICTED.	333.2	304.2	22.1	OCT 77	JAN 81
2 77 9857	AUTO SEPARATION, CARRIER MOUNTING + TESTING OF SEMI-COT DICE HONEYWELL BUILT 54 COMMUTATOR MODULES, 60 MEMORY SUBSTRATES AND 68 SINGLES CIRCUITS. USE OF TAPE CARRIER PERMITTED PRE-TEST OF SEMICONDUCTOR CHIPS BUT THERE WERE OTHER PROBLEMS-CIRCUIT COMPLEXITY, LACK OF TAPES, COST OF DEVELOPING BONDING UNITS.	1,275.0	1,129.3	119.7	OCT 79	MAR 81
M 78 9860	PDN TECHNIQUE-GALLIUM ARSENIDE NIMAY FIELD EFFECT TRANSISTORS HUGHES BUILT GAS-AS FET TRANSISTORS ON A PRODUCTION LINE AND THEY HAD GOOD ELECTRICAL PROPERTIES. UNITS PACKAGED IN A TYPE I PACKAGE TESTED ON TYPE II PACKAGES WILL BE DELIVERED NEXT. PROCESS MANUAL IS INADEQUATE. HUGHES ASKED FOR 4 MONTHS EXTENSION.	469.3	399.3	6.5	NOV 80	FEB 81
2 77 9873	ANTENNA PATTERN MEASUREMENTS USING NEARFIELD TECHNIQUES THE NEAR FIELD MEASUREMENT SYSTEM HAS BEEN INSTALLED. THE INITIAL TECH. MEASUREMENTS ON THE HORN, AND VERT. PROBE POSITIONING ACCURACIES ARE ENCOURAGING. THIS PROJECT COULD SLIP 9 MO. AS THE ANTYP037 ANTENNA WILL NOT BE AVAILABLE UNTIL NOV 1980.	625.3	598.3	27.0	OCT 79	FEB 80

MANUFACTURING METHODS AND TECHNOLOGY PROGRAM
 SUMMARY REPORT
 2ND SEMIANNUAL SUBMISSION CY 79 RCS DRCHT-301

PROJ NO.	TITLE + STATUS	AUTHORIZED (\$000)	CONTRACT VALUES (\$000)	EXPENDED LABOR AND MATERIAL (\$000)	ORIGINAL PROJECTED COMPLETE DATE	PRESENT PROJECTED COMPLETE DATE
M 79 9877	LIGHT EMITTING DIODE ARRAY COMMON MODULE SPECTRONICS IS MODIFYING TWO COMPANY-OWNED REACTORS TO GROW GALLIUM ARSENIDE PHOSPHIDE MATERIAL FLIGHT EMITTING DIODES. NEW PHOTO MASKS WERE ORDERED FOR IMPROVED ARRAY LEAD GEOMETRY. METALLIZED CERAMIC HEADERS WERE CONFIGURED REACTOR 1 SEMIAUTOMATIC.	600.0	550.5	14.0	APR 81	MAR 81
M 78 9889	THIRD GENERATION 0.9 MICRON WAFER INTENSIFIER TUBE SEE TASKS A AND B BELOW.	1,772.1	1,612.1	65.0	JUN 81	JUN 81
M 78 9899 A	THIRD GENERATION 0.9 MICRON WAFER INTENSIFIER TUBE (ITT) (EOPD) COMPLETED DESIGN OF PROCESS AUTOMATION EQUIPMENT AND ORDERED PARTS. FIXTURING FOR THE 12-TUBE PROCESS CHAMBER WAS INSTALLED AND IS BEING VACUUM BAKED. TO BE OPERATIONAL IN JAN 80. 5 MONTH DELAY IN TUBE DELIVERY CAUSED BY LACK OF CATHODES.	712.1	632.1	50.0	JUN 81	JAN 81
M 78 9899 B	THIRD GENERATION 0.9 MICRON WAFER INTENSIFIER TUBE (VARIAN) VARIAN COMPLETED ITS BATCH PROCESS SYSTEM AND TUBE TEST FACILITY. SAMPLE TUBES PROCESSED IN THE NEW VACUUM SYSTEM DEMONSTRATED THE BATCH PROCESS CAPABILITY. BUT 3 MONTH DELAY WAS CAUSED BY SHORTAGE OF GOOD ION BARRIER FILMED MICRO CHANNEL PLATES.	1,060.0	980.0	15.0	JUN 81	JUN 81
M 80 9897	SURFACE ACOUSTIC WAVE RESONATOR + REFLECTIVE ARRAY DEVICES A PRELIMINARY WORK PACKAGE HAS BEEN SUBMITTED. CONTRACT AWARD IS EXPECTED IN MAY 80. FREQUENCY TRIMMING AND MAINTAINING A LOW AGING RATE ARE THE MAJOR PROBLEMS THAT ARE EXPECTED.	300.0			AUG 82	AUG 82

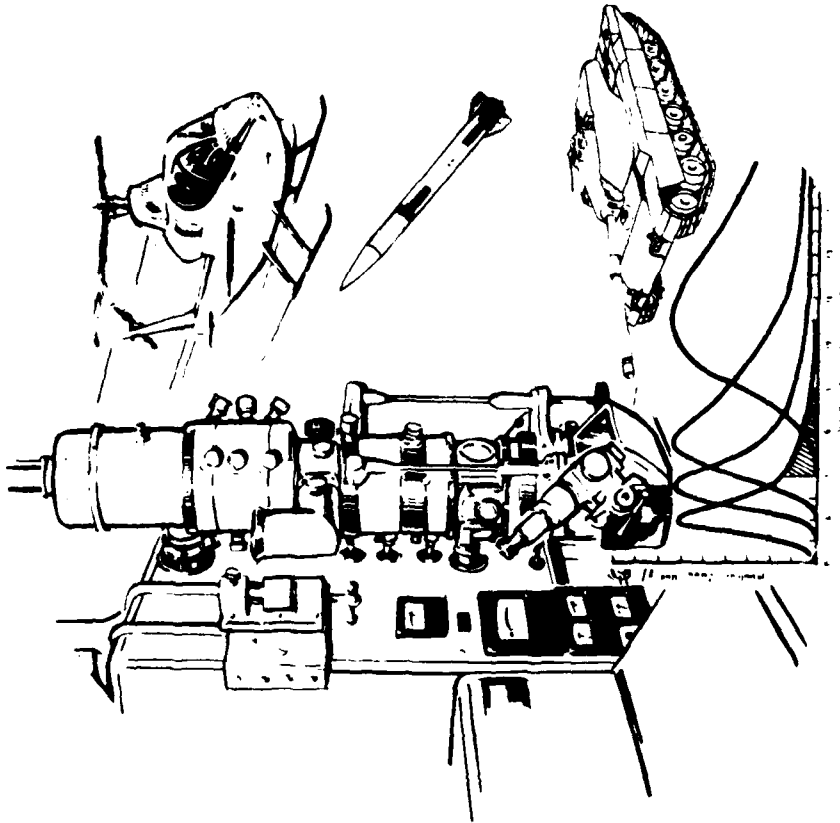

**MATERIALS AND MECHANICS RESEARCH CENTER
(AMMRC)**

**US ARMY MATERIEL DEVELOPMENT AND READINESS COMMAND
(DARCOM)**

PRECEDING PAGE BLANK-NOT FILLED

HEADQUARTERS-DARCOM * ARMY MATERIALS AND MECHANICS RESEARCH CENTER

CURRENT FUNDING STATUS, 2ND CY79

FISCAL YEAR	NO. OF PROJECTS	AUTHORIZED FUNDS (\$)	* CONTRACT FUNDS ALLOCATED (\$)	* CONTRACT FUNDS EXPENDED (\$)	* CONTRACT FUNDS REMAINING (\$)	* FUNDING EXPENDED (\$)	* FUNDING REMAINING (\$)
76	1	449,900	449,900	434,800 (96%)	0	0 (0%)	0 (0%)
77	1	383,000	383,000	211,400 (55%)	0	0 (0%)	0 (0%)
77	2	4,305,000	1,259,500	1,131,100 (89%)	3,045,500	3,045,400 (99%)	3,045,400 (99%)
78	3	5,205,000	1,710,200	1,262,700 (73%)	3,494,800	3,371,300 (96%)	3,371,300 (96%)
79	3	5,215,000	2,220,100	1,847,300 (82%)	2,986,900	2,862,300 (95%)	2,862,300 (95%)
80	3	5,114,000	0	0 (0%)	5,114,000	0 (0%)	0 (0%)
81	0	0	0	0 (0%)	0	0 (0%)	0 (0%)
82	0	0	0	0 (0%)	0	0 (0%)	0 (0%)
TOTAL	13	20,671,900	6,030,700	4,887,300 (81%)	14,641,200	9,279,000 (63%)	9,279,000 (63%)

AUTHORIZED FUNDING CONTRACT ALLOCATED 29% INHOUSE REMAINING 70%

MANUFACTURING METHODS AND TECHNOLOGY PROGRAM
 S U M M A R Y P R O J E C T S T A T U S R E P O R T
 2ND SEMI-ANNUAL SUBMISSION CY 79 RCS DRCHT-301

PROJ NO.	TITLE + STATUS	AUTHO- RIZED (\$000)	CONTRACT VALUES (\$000)	EXPENDED		PRESENT PROJECTED COMPLETE DATE
				LABOR AND MATERIAL (\$000)	PROJECTED COMPLETE DATE	
M 77 6350	MATERIALS TESTING TECHNOLOGY (MTT) SEE THE SUBTASK BELOW FOR PROJECT STATUS.	4,000.0	1,051.5	2,946.5	MAY 78	APR 80
M 77 6350 1642	NOT OF DOD FILTER IN BANNER ENGINEERING CORP PLANT NO SEMI-ANNUAL STATUS REPORT RECEIVED.					
M 77 6350 2007	MEAS GAGE DEPTH OF CARBURIZED GEARS BY ELECTROMAG TECH THE CONTRACT WAS AWARDED 21 MAY 79, THE EQUIP. AND INSTRUMENTATION HAS BEEN DELIVERED TO THE CONTRACTOR. THE MACHINING OF 80 GEARS WAS COMPLETED AND THE CARBURIZING SCH HAVE BEEN ESTABLISHED. THE DESIGN FOR THE PROBE COIL WAS COMPLETED.	94.0		6.4	JUN 80	JUN 80
M 77 6350 2009	IMPROVED ULTRASONIC TEST INSTRUMENTATION A FAST SCANNING PROTOTYPE ULTRASONIC INSPECTION SYS WAS BUILT. THIS TECHNIQUE HAS BEEN DEMONSTRATED TO BE A VALUABLE TOOL FOR INSP. ROTATING BANDS. THIS TECH. IS BEING CONSIDERED FOR INERTIA WELDED HANDS ON THE 483 PROJECTILE.	120.0		120.0		DEC 79
M 77 6350 2014	PORTABLE NEUTRON RADIOGRAPHY SYS - ENGR MODEL THE EVALUATION OF THE SYS. IS PROGRESSING THROUGH THE RADIOGRAPHY OF SELECTED SPECIMENS AT THE CONTRACTOR'S PLANT. THE INCREASED TRI-SERVICE INTEREST HAS LED TO EXPAND THE VALIDATION EFFORT WHICH WILL REQUIRE ADDITIONAL FUNDING.	525.0	515.0	9.5	AUG 80	AUG 80
M 77 6350 2028	GUN TUBE CHAMBER PROFILE INSPECTION SYSTEM THE GAGING SYS HAS BEEN ACCEPTED WITH THE EXCEPTION OF THE BODY. SEVERAL PHY. DIMENSIONS WERE NOT CORRECT. AS A RESULT, THE GAGE WAS RETURNED TO THE CONTRACTOR. DUE TO THE SE PROBLEMS, A TIME EXTENSION FOR THIS TASK HAS BEEN REQUESTED.	60.0	61.3	1.6	MAY 80	MAY 80
M 77 6350 2029	MINI COMPUTER MAPPING OF FATIGUE CRACKS IN THREADS SUB TASK HAS BEEN COMPLETED. THIS WORK IS BEING CONTINUED UNDER SUBTASK NO. 2429. FOR STATUS SEE PROJECT NO M 79 6350 SUBTASK NO 2429.	66.0		66.0	NOV 79	NOV 79
M 77 6350 2054	ESTAB OF ULTRASONIC STANDARDS PROCUR OF ARMOR PLATE THE FRACTURE SAMPLES WERE CUT AND THE FRACTURE TEST WAS PERFORMED. THE LAMINATIONS WERE FOUND TO BE FAR LARGER THAN INDICATED BY THE ULTRASONIC EXAMINATION. IT APPEARS THAT THE LAMINATIONS GREW DURING THE FRACTURE TEST.	46.0		46.0	DEC 79	DEC 79
M 77 6350 2215	RADAR METHOD FOR SENSING AND OUTPUT TESTING OF DETONATOR A COMPUTER PROGRAM HAS BEEN WRITTEN TO ANALYZE THE RADAR DIGITAL DATA FORMAT. THE PROGRAM IS BEING USED ON A SERIES OF SIMULATED RADAR SIGNALS. THESE SIMULATIONS WILL BE USED FOR ESTABLISHING THE PARAMETERS THAT ARE REQ FOR FRAG VELOCITY RESOLUTION.	210.0	66.0	13.0	JAN 81	JAN 81

S U M M A R Y P R O J E C T S T A T U S R E P O R T
 2ND SEMIANNUAL SUBMISSION CY 79 RCB DRCMT-301

MANUFACTURING METHODS AND TECHNOLOGY PROGRAM

PROJ NO.	TITLE + STATUS	AUTHORIZED	CONTRACT VALUES	EXPENDED LABOR AND MATERIAL (\$000)	ORIGINAL PROJECTED COMPLETE DATE	PRESENT PROJECTED COMPLETE DATE
M 77 6350 2403	IMPROVED STANDARDIZED WEAPON CHAMBER PRE-SURE MEAS THE GAGES HAVE ORDERED. 80 PERCENT OF THE EQUIP HAS BEEN RECEIVED. 50 PERCENT OF THE MOUNTING ADAPTORS HAVE BEEN DESIGNED AND MACHINED. 90 PERCENT OF THE TEST PLAN HAS BEEN WRITTEN. ARRANGEMENTS HAVE BEEN MADE FOR 175MM GUN AND AMO FOR FIELD TESTING.	90.0	28.6	28.6	SEP 80	SEP 80
M 77 6350 2421	INSPECT FOR THREADS UN M223 FUZE A LONGER THAN ANTICIPATED PROCUREMENT CYCLE DELAYED THE COMPLETION DATE OF THIS EFFORT BY ONE YEAR. THE CONTRACT WAS AWARDED AUG 1979.	195.0	120.0	35.0	JAN 81	JAN 81
M 77 6350 2431	COMPUTERIZED COLOR MATCHING SYSTEM THE CONTRACT HAS BEEN COMPLETED AND A DRAFT REPORT SUBMITTED. AN RFP FOR A TWO-UNIT SYSTEM IS BEING PREPARED. WITH MODIFICATIONS, THE THREE INSTRUMENTS TESTED WILL CONFORM TO THE STATED RFP REQ.	420.0	236.9	236.9	APR 81	APR 81
M 77 6350 2450	ADHESION OF CHROMIUM + COATINGS WITH GUN STEEL THE DESIGN SPECIFICATIONS FOR THE CONSTRUCTION OF AN ULTRACENTRIFUGAL ADHESION TESTER WAS ESTABLISHED. POTENTIAL VENDORS WERE CONTACTED TO DETERMINE THE AVAILABILITY OF THEIR SERVICES, FACILITIES AND TECHNICAL CAPABILITIES.	23.9	3.5	3.5	OCT 80	OCT 80
M 78 6350	MATERIALS TESTING TECHNOLOGY (MTT) SEE SUBTASK BELOW FOR PROJECT STATUS.	4,500.0	1,204.7	3,295.3	JUN 79	APR 81
M 78 6350 2034	NOT FOR E-BEAM FOIL WINDOWS THIS SUBTASK HAS BEEN COMPLETED. THE FINAL REPORT IS BEING PREPARED AND IS SCHEDULED FOR PUBLICATION 29 FEB 1980.	93.8	55.0	38.8	OCT 79	DEC 79
M 78 6350 2200	SIZING AND COUNTING CONTAMINANTS IN RECOIL HYDRAULIC AN EFFORT TO CONTRACT THE REMAINDER OF THE WORK FOR THIS PROJECT IS UNDERWAY. THE CONTRACT APPROACH IS BEING PURSUED DUE TO THE LACK OF PERSONNEL.	90.0	33.5	25.1	APR 80	APR 80
M 78 6350 2201	HOT ROTARY FORGED TUBE LASER GAGE MEASUREMENT THE FAB OF THE SYSTEM HAS STARTED. THE FAB OF THE LASER'S LARGE PARABOLIC MIRROR HAS BECOME PROBLEM. THE MIRROR SUBCONTRACTOR HAS HAD TO DELAY THE DELIVERY TWICE DUE TO WORKLOAD AND PERSONNEL PROBLEMS. A TIME EXTENSION HAS BEEN GRANTED.	115.0	96.0	9.2	JUN 80	JUN 80
M 78 6350 2202	DYNAMIC T-1ST MEASUREMENT OF RIFLING MACHINES THE ENVELOPE AND CONTROLLING CALCULATOR HAVE BEEN RECEIVED. THE ROTARY ENCODER WAS RETURNED THE 2ND TIME TO CORRECT THE ERROR IN THE MEASUREMENT ACCURACY. THIS HAS CAUSED A DELAY IN THE PROJECT. AN EXTENSION HAS BEEN GRANTED BY AMMRC.	36.0	5.9	24.0	APR 80	APR 80

SUMMARY PROJECT STATUS REPORT
2ND SEMI-ANNUAL SUBMISSION CY 79 RCS DRCHT-301

MANUFACTURING METHODS AND TECHNOLOGY PROGRAM

PROJ NO.	TITLE + STATUS	AUTHORIZED (\$000)	CONTRACT VALUES (\$000)	EXPENDED LABOR AND MATERIAL (\$000)	ORIGINAL PROJECTED COMPLETE DATE	PRESENT PROJECTED COMPLETE DATE
M 78 6350 2203	BALLISTIC IMPACT TEST SHATTERING RESISTANCE OF ARMOR MIL-DUCTILITY BALLISTIC IMPACT TESTS HAVE BEEN COMPLETED ON 16 UP3 PERCENT N1 MODIFIED 4335 STEEL, EIGHT AMMRC ESR MEAT NO 54 AND 8 AMMRC ESK MEAT NO 35 WERE BALLISTICALLY IMPACTED FROM ROOM TEMPERATURE TO -95F WITH 20MM PROOF PROJECTILE.	75.0		33.2	SEP 80	SEP 80
M 78 6350 2205	MOLOGRAPHIC INSPECTION OF ROTARY FORGED PREFORMS THE SOLE SOURCE CONTRACTING EFFORT HAS BEEN TERMINATED DUE TO THE BANKRUPTCY OF THE FIRM. AN EFFORT IS UNDERWAY TO ESTABLISH A NEW SOURCE. THIS BANKRUPTCY HAS DELAYED THE PROJECT BY 10 MONTHS.	80.0		16.0	NOV 80	NOV 80
M 78 6350 2206	OPTICAL DETERMINATION OF DIMENSIONAL GAPS ON TANK PROJECTILE THE EFFORT IS ON SCHEDULE. THE CONTRACTOR IS SCHEDULED TO COMPLETE THE FAB EFFORT 31 DEC 79. A COST OVER RUN OF APPROX 23K HAS BEEN INCURRED. AMMRC HAS BEEN REQUESTED TO PROVIDE THESE ADDITIONAL FUNDS.	100.0	65.5	15.0	MAY 80	MAY 80
M 78 6350 2208	ON-LINE MISTUREPROOFNESS VERIFIER /EXPL FUZE TRAIN COMPARE DUE TO EQUIP MALFUNCTIONS, THE FINAL LAB TESTS ON LIVE DETONATORS HAVE NOT BEEN COMPLETED. THESE TESTS WILL BE CONDUCTED CONCURRENTLY WITH THE M-55 DETONATOR. THE TESTING IS NEARING COMPLETION AND THE DATA ANALYSIS IS IN-PROCESS.	38.0	9.0	24.3	MAR 80	MAR 80
M 78 6350 2211	STABILITY PENETRATION AUTOMATIC INSPECTION SYSTEM THIS WAS A PARALLEL EFFORT TO DEVELOP AN AUTOMATIC STABILLY CORE INSP. SYST. SINCE THE INCEPTION OF THIS EFFORT, AN ACCEPTABLE INSP. SYS HAS BEEN DEVELOPED BY ANOTHER CONTRACTOR. THEREFORE THERE IS NOT ANY PLAN TO CONTINUE THIS EFFORT.	256.0		35.0	DEC 79	DEC 79
M 78 6350 2212	MEAS STATISTIC DETONATED ME MORTOR PROJ WITH RADAR IT WAS DETERMINED FROM THE PRELIMINARY RESULTS THAT THIS PROJECT COST WOULD EXCEED THE AVAILABLE FUNDS. THEREFORE, IT WAS CANCELLED.	80.0		38.0	DEC 79	DEC 79
M 78 6350 2213	LASER INTERFEROMETER CALIBRATION STATION THE SYS WAS DELIVERED IN OCT 1979. AT THIS TIME OTHER FIXTURES ARE BEING FAB. AND TESTED. THE LATE DELIVERY OF THE SYS HAS REQUIRED AN EXTENSION OF THE PROJECT. AMMRC HAS GRANTED AN EXTENSION.	60.0	5.8	38.0	APR 80	APR 80
M 78 6350 2214	ELECTROTHERMAL ANALOG RESPONSE INSP OF EEDIS ARRADCOM 12-78 SEE PROJECT NO M 79 6350 SUBTASK NO 2414 FOR STATUS.	75.0	50.0	20.0	OCT 80	OCT 80
M 78 6350 2218	COMPUTER AIDED AUTO TEST OF HYBRID SUBSTRATES FURTHER INVESTIGATION INTO THE CHARGE DISPERSAL PROBLEM IS CONTINUING. VARIOUS METHODS OF MINIMIZING THE PROBLEM HAVE BEEN REVIEWED INCLUDING SEQUENCING TO OTHER CONDUCTOR SURFACES TO ALLOW TIME FOR THE CHARGE TO DISSIPATE.	100.0		79.2	FEB 80	FEB 80

MANUFACTURING METHODS AND TECHNOLOGY PROGRAM
 S U M M A R Y P H A S E C Y S T A T U S M F P U M T
 2ND SEMIANNUAL SUBMISSION CY 79 KCS URCMT-301

PROJ NO.	TITLE + STATUS	AUTOMATIZED (\$000)	CONTRACT VALUES (\$000)	EXPENDED LABOR AND MATERIAL (\$000)	ORIGINAL PROJECTED COMPLETE DATE	PRESENT PROJECTED COMPLETE DATE
M 78 6350 2220	MECHANICAL TEST FOR COMPOSITES IN TUBULAR SHAPES THE FLAWS DETECTION OF ARTIFICIALLY FLAWED SPECIMENS HAS NOT BEEN REALIZED USING MOULOGRAPHIC OR ELECTRO-MECH METHODS. THE COMPUTER CODES CAN NOT RELIABLY PREDICT STRESS STATES BEYOND THE YIELD STRESS.	75.0		72.0	JUL 80	JUL 80
M 78 6350 2221	RAPID METH DET BALLISTIC CHAR OF PROPELLANT SURTASK HAS BEEN COMPLETED. THE USE OF A CLOSED VESSEL TO DETERMINE THE BURN RATE OF UNCURED PROPELLANT HAS BEEN DEMONSTRATED. THIS METHOD CAN BE USED DURING THE PROPELLANT MFG PROCESS THAT WILL ALLOW ADJUSTMENTS TO INSURE THE REQUIRED BURN RATE.	90.0	3.0	86.5	DEC 79	DEC 79
M 78 6350 2224	AUTOMATED ANTENNA PATTERN MEASUREMENT THE ACTIVITIES DURING THIS REPORTING PERIOD WERE DIRECTED TOWARDS FABRICATION AND TESTING OF INTERFACES, ASSEMBLY AND TESTING OF MEASUREMENT SYSTEM HARDWARE AND GENERATION OF SYSTEM SOFTWARE.	45.0		45.0	DEC 79	DEC 79
M 78 6350 2225	3-D SHOCK/VIBRATION TEST FOR MISSILE ARTLY FUZE MAIL ONLY ONE CONTRACTOR WAS RESPONSIVE TO THE RFP. THIS PROPOSAL WAS EXTREMELY HIGH IN COSTS. NEGOTIATIONS WILL BE HELD TO ACHIEVE AS A MINIMUM THE REQUIRED OBJECTIVES WITHIN THE AVAILABLE FUNDS. THESE NEGOTIATIONS WILL DELAY THE COMPLETION OF THE PROJ.	69.6		16.0	NOV 80	NOV 80
M 78 6350 2226	AIR FLUM TEST EQUIPMENT ALL OF THE MAJOR COMPONENTS HAVE BEEN RECEIVED. THE TEST CHAMBER, CONTROLLER ELECTRONICS HAVE BEEN FABRICATED. THE SOFTWARE HAS BEEN MODIFIED. A TEST PROGRAM HAS BEEN WRITTEN. DUE TO PROCUREMENT DELAYS, THE TASK HAS SLIPPED 6 MONTHS.	65.0		60.1	AUG 80	AUG 80
M 78 6350 2227	SETBACK DRAG TESTER FOR SAA DEVICES PHOTOGRAPHS WERE TAKEN OF TEST SHOTS. ANALYSIS OF THE PHOTOGRAPHIC DATA CONFIRMED THAT THE IMPACT PHASE OF THE TEST PRODUCES MAJOR SETBACK FORCES FROM 3600 TO 4700G. TO DATE, 12 TEST FIRINGS HAVE BEEN MADE IN THE SIMULATION.	86.0		52.0	JUN 80	JUN 80
M 78 6350 2229	ANALYSIS OF CHITIN IN CONTAMINATED JET AIRCRAFT FUELS THE LITERATURE SEARCH INDICATED THAT LITTLE WORK HAS BEEN DONE IN THIS AREA. THE NAVY INDICATED THAT THERE IS A FUNGI PROBLEM WITH FUELS USED IN MARINE APPLICATIONS. COMMERCIAL AIRLINES CONTROL THEM BY ADDING DIACIDES.	40.0	0.6	21.3	JUN 80	JUN 80
M 78 6350 2230	ANALYSIS OF SYNTHETIC OIL CRANKCASE LUBRICANTS A REQUEST FOR AN ADDITIONAL IQA WAS SUBMITTED TO CONTINUE THIS TASK. DIFFICULTIES HAVE BEEN ENCOUNTERED IN DETECTING MAJOR COMPONENTS OF OIL SAMPLES USING THE EXISTING VAV. DETECTOR. AN INFRA-RED DETECTOR WILL BE REQ. TO CONTINUE THIS TASK.	70.0		70.0	DEC 79	JUL 80

SUMMARY PROJECT STATUS REPORT
2ND SEMIANNUAL SUBMISSION CY 79 KCS DRGWT-301

MANUFACTURING METHODS AND TECHNOLOGY PROGRAM

PROJ NO.	TITLE + STATUS	AUTHORIZED (\$000)	CONTRACT VALUES (\$000)	EXPANDED LABOR AND MATERIAL (\$000)	ORIGINAL PROJECTED COMPLETE DATE	PRESENT PROJECTED COMPLETE DATE
M 78 6350 2233	TRACK BUSHING TEST MACHINE THE BUSHING TESTING PORTION OF THE PROJECT IS IN PROGRESS. THE TEST SAMPLES HAVE BEEN EXPANDED FROM 24 TO 48. FUNDS HAVE BEEN MADE AVAILABLE TO BUILD TWO MACHINES.	105.0		167.0	FEB 80	FEB 80
M 78 6350 2235	ACOUSTIC EMISSION FELD INSPECTION TASK HAS BEEN COMPLETED, THE REVIEW OF THE FINAL REPORT IS IN PROGRESS. THIS REPORT IS SCHEDULED TO BE COMPLETED IN JAN. 1980.	40.0	33.0	5.2	NOV 79	NOV 79
M 78 6350 2236	HOT CORROSION RIG TESTING STANDARDIZATION A FINAL REPORT IS BEING PREPARED. RESULTS HAVE DEMONSTRATED THAT HOT CORROSION PENETRATION MEASUREMENT IS A FEASIBLE METHOD BY WHICH HIGH TEMPERATURE ALLOYS CAN BE RANKED AS TO THEIR RESISTANCE TO HOT CORROSION.	75.0		75.0	NOV 79	FEB 80
M 78 6350 2237	UNIDIRECTIONAL COMPOSITE MATERIALS NO SEMI ANNUAL STATUS REPORT RECEIVED.					
M 78 6350 2241	DIELECTRIC TECH FOR 40E NON-CONDUCTING CERAMIC MATL THE PROCUREMENT ACTIVITY IS NEARING COMPLETION. THE SCOPE OF THE CONTRACT INCLUDES, ADEPTING THE CAPABILITIES OF ELECTROMAGNETIC FIELD PROBES FOR SURFACE DEFECTS & ACQUIRE CERAMIC TEST PLATES CONTAINING Voids, INCLUSIONS AND CRACKS.	850.0		6.0	JUL 81	JUL 81
M 78 6350 2245	NONDESTRUCTIVE EVALUATION OF CERAMIC MATERIALS A REVIEW OF FLAWS, TYPE AND LOCATION, REQUIRED TO BE DETECTED IN THE VARIOUS CERAMIC MATL, AS PRODUCED BY VARIOUS FAP, PROCESSES HAS BEEN COMPLETED. ALSO, A REVIEW OF NDT TECHNIQUES FOR CERAMICS AS WELL AS ADVANCED NOT HAS BEEN COMPLETED.	150.0		2.7	DEC 80	DEC 80
M 78 6350 2247	ULTRASONIC SPECTROSCOPY INSPECT ADHESIVE BUNDED STRUCT A CONTRACT WAS AWARDED IN SEPT. 1979 TO INVESTIGATE THE USE OF ULTRASONIC SPECTROSCOPY FOR BOND STRENGTH DETERMINATION IN COMPOSITE HELICOPTER BLADES. SINCE THE PROGRAM JUST STARTED, NO SIGNIFICANT PROGRESS HAS BEEN MADE YET.	100.0	44.0	50.0	SEP 81	SEP 81
M 78 6350 2248	FAST ULTRASONIC INSPECTION OF ARTILLERY SHELLS THE LINEAR ARRAY TECHNIQUE IS AN EXCELLENT APPROACH FOR INSPECTING INERTIA WELDED ROTATING BANDS. A DECISION WHETHER TO CONTINUE THE INERTIA WELDING OF M403 ROTATING BAND WILL BE MADE THIS SUB-FP. WORK OF THE VERSATILE ELECTRONIC PACKAGE IS CONTINUING.	50.0		3.0		SEP 80
M 78 6350 2250	CHEMICAL CHARACTERIZATION OF GRAPHITE FIBERS MANY PROBLEMS HAVE BEEN ENCOUNTERED IN ATTACKING SAMPLE FOR DISSOLUTION. IT IS NOT EXPECTED THAT REMAINING FUNDS WILL PERMIT EMISSION SPECTROGRAPHIC TESTING. IT APPEARS THAT AN ADDITIONAL \$5K WILL BE REV. TO SUCCESSFULLY COMPLETE THIS TASK.	30.0		23.3	APR 80	APR 80

S U M M A R Y P R O J E C T S T A T U S R E P O R T
 2ND SEMIANNUAL SUBMISSION CY 79 RCS DRCMT-301
 MANUFACTURING METHODS AND TECHNOLOGY PROGRAM

PROJ NO.	TITLE + STATUS	AUTHORIZED VALUES (\$000)	CONTRACT VALUES (\$000)	EXPENDED LABOR AND MATERIAL (\$000)	ORIGINAL PROJECTED COMPLETE DATE	PRESENT PROJECTED COMPLETE DATE
M 78 6350 2251	CHEMICAL CHARACTERIZATION BY ESCA, AES, AND SIMS SUBTASK WAS COMPLETED AND A FINAL SUMMARY REPORT WAS SUBMITTED. THE TEST PROCEDURES, SAMPLE PREPARATION RECOMMENDATIONS, SAMPLE MOUNTING AND SPECTROMETER MEASUREMENT TECH, USING ESCA, AES, SIMS ARE AVAILABLE FOR SURFACE PROCUREMENT SPECIFICATIONS.	55.0		55.0	SEP 78	DEC 79
M 78 6350 2252	INSPECTION PROCEDURES FOR COMP OF HYDRAULIC FLUIDS SUBTASK HAS BEEN COMPLETED. A FINAL TECHNICAL REPORT HAS BEEN WRITTEN, TWO PAPERS WERE WRITTEN AND ACCEPTED FOR 1980 PUBLICATIONS BY JOURNAL OF LIQUID CHROMATOGRAPHY AND LUBRICATION ENGINEERING.	7.2	1.4	6.7	JUN 79	DEC 79
M 78 6350 2253	SEGREGATION TEST BY X-RAY FLOURESCENCE ANALYSIS SUBTASK HAS BEEN COMPLETED. METHODS HAVE BEEN ESTABLISHED TO DETERMINE THE FEASIBILITY OF SEGREGATION STUDIES FOR MATLS RANGING FROM VERY HOMOGENEOUS ESR LOW ALLOY STEELS TO HIGHLY SEGREGATED WELD COMPONENTS.	50.0		50.0	NOV 79	DEC 79
M 78 6350 2254	ELECTROMAGNETIC TECH FOR DETERMINATION OF STRESS GEAR PROBE FIXTURE DESIGN AND FAB, FOR MEASURING RESIDUAL STRESS IN ROOT AREAS OF GEAR TEETH WAS COMPLETED. ADDITIONAL INSTRUMENTATION WAS PROCURED TO INCREASE THE VERSATILITY OF THE TEST TECHNIQUE.	65.0	17.2	39.6	FEB 80	FEB 80
M 78 6350 2258	FUZE TEST MACHINE NO SEMI ANNUAL STATUS REPORT RECEIVED.					
M 78 6350 2402	INSP PROC - TEST INSTRU F/MASS PROO SCATTERABLE MINES MICRO THE MICROPROCESSOR DEVELOPMENT LABORATORY HAS BEEN RECEIVED. PLAN TO ESTABLISH A PRODUCT ASSURANCE DIVISION EMBEDDED PROCESSOR EVALUATION GROUP HAS BEEN ANNOUNCED. THE FINAL REPORT IS SCHEDULED TO BE PUBLISHED 2ND QTR, FY80.	38.0	30.0	4.7	JAN 82	JAN 82
M 78 6350 2411	EVAL + APPL PYROELECTRIC VIVICON TO SHELTER PANELS THE TECHNICAL EVALUATION OF THE PROTOTYPE PYROELECTRIC VIDICON SYSTEM IS IN-PROCESS. THE SYSTEM IS BEING COMPARED WITH COMMERCIAL IN-FRARED IMAGING SYSTEM FOR SENSITIVITY AND EASE OF OPERATION.	115.0		27.0	JUL 80	JUL 80
M 78 6350 2423	INSP. OF K-ORL FOR 155MM M549 RAP A CONTRACT WITH A REDUCED SCOPE OF WORK WAS AWARDED SEPT 29 1979. ADDITIONAL FUNDS HAVE BEEN REQUESTED TO RESTORE THIS PROJECT TO THE ORIGINAL OBJECTIVES-A SEMI-AUTOMATED SYS SUITABLE FOR PRODUCTION. AN ADDITIONAL FUNDS REQ IS EST. TO BE 95 TO 127K.	162.0	115.0	35.1	OCT 80	OCT 80

S U M M A R Y P R O J E C T S T A T U S R E P O R T
 2ND SEMIANNUAL SUBMISSION CY 79 RCS DRGCMT-301

MANUFACTURING METHODS AND TECHNOLOGY PROGRAM

PROJ NO.	TITLE + STATUS	AUTHORIZED (\$000)	CONTRACT VALUES (\$000)	EXPENDED LABOR AND MATERIAL (\$000)	ORIGINAL PROJECTED COMPLETE DATE	PRESENT PROJECTED COMPLETE DATE
M 78 6350 2434	<p>RAPID NOT FOR DOPANT DENSITY AND DISTRIBUTION A ROD MEASUREMENT PROGRAM IS BEING CONDUCTED AT FT. BELVOIR. CORRELATIONS WERE MADE WITH MODS USED BY SIEMENS, WEST GERMANY. THE RESULTS OBTAINED WERE EXCELLENT. THE 2ND GENERATION MEASUREMENT SET-UP IS BEING IMPLEMENTED.</p>	19.0	19.0	19.0	MAR 80	MAR 80
M 78 6350 2442	<p>APPLICATION OF RADIOGRAPHIC TESTING PROCEDURES IN THE X-RAY AREA, A TECHNICAL REPORT TITLED "EVALUATION OF COMPOSITE RADIOGRAPHIC SCREENS" WAS COMPLETED. NEUTRON RADIOGRAPHIC AND ACTIVATION TECHNIQUES WERE DEVELOPED TO SORT VARIOUS TYPES OF SMELLS CONTAINING PHOSPHOROUS.</p>	140.0	70.0	70.0	JUN 80	JUN 80
M 78 6350 2443	<p>ULTRASONIC CLEANLINESS RATING OF STEEL THE MICROCOMPUTER FOR THIS PROGRAM WAS RECEIVED. THE COMPUTER CONTROLLED PULSER-RECEIVER HAS BEEN AWARDED AND DELIVERY IS SCH. FOR FEB 1980. TO DATE, A NUMBER OF COMPUTER PROGRAMS HAVE BEEN WRITTEN FOR THIS PROJECT.</p>	125.0	115.0	115.0	SEP 80	SEP 80
M 78 6350 2449	<p>GENERAL PURPOSE RESIDUAL STRESS ANALYZER THE RESIDUAL STRESS ANALYZER WAS TESTED USING A STEEL STD. THE TESTS WERE SATISFACTORY IN THAT THEY AGREED WITH PREVIOUS RESULTS OBTAINED FROM THE DIVERGENT BEAM CALIBRATION. THE COMPUTER PROGRAMS FOR AUTOMATIC OPERATION WERE TESTED.</p>	25.0			JUN 80	JUN 80
M 79 6350	<p>MATERIALS TESTING TECHNOLOGY (MTT) SEE SUBTASK HELDM FOR PROJECT STATUS.</p>	4,470.0	1,648.8	2,821.2		APR 82
M 79 6350 2025	<p>AUTO INSPECTION DEVICE FOR EXPLOSIVE CHARGE IN SHELL THE FAB OF THE ENGR. MODEL WAS ESSENTIALLY COMPLETED. SEVERAL MECHANICAL FAILURES OCCURRED WHICH HAS REQ. AN EXTENSION OF TIME. THE PROGRAM WAS HALTED SEVERAL WKS. WHILE NEGOTIATIONS WERE UNDERWAY TO RESOLVE THE COST ISSUE ASSOCIATED WITH THE FAILURE</p>	531.5	228.3		JAN 80	JAN 80
M 79 6350 2209	<p>HOLOGRAPHIC DEFECT DETECTION BY PRESSURE STRESSING THE LITERATURE SEARCH INDICATED THAT THE OBJECTIVES OF THIS EFFORT WOULD BE MORE READILY MET USING THE LOCAL REFERENCE BEAM HOLOGRAPHIC TECH. THE PROTOTYPE EQUIP WAS FAB, BUT DOES NOT DUPLICATE THE LAB. RESULTS. LAB WORK IS REQ TO RESOLVE THE PROBLEM</p>	150.0	7.0	143.0	JAN 80	JAN 80
M 79 6350 2401	<p>CANNON TUBE AUTOMATIC MAGNETIC BURESCOPE INSPECTION CONTRACT WITH SOUTHWEST RESEARCH INSTITUTE FOR TWO MRR SYSTEMS WAS AWARDED 1 OCT 79. THE CONTRACT IS SCHEDULED FOR COMPLETION JUNE 1980. THE ADDITIONAL FUNDS OF 106K WAS MADE AVAILABLE BY APG AND MATERVELLET.</p>	191.0	161.0	21.5	JUL 80	JUL 80

S U M M A R Y P R O J E C T S T A T U S R E P O R T
 2ND SEMIANNUAL SUBMISSION CY 79 RCS DRCHT-301

MANUFACTURING METHODS AND TECHNOLOGY PROGRAM

PROJ NO.	TITLE + STATUS	AUTOMATIZED (\$000)	CONTRACT VALUES (\$000)	EXPANDED LABOR AND MATERIAL (\$000)	ORIGINAL PROJECTED COMPLETE DATE	PRESENT PROJECTED COMPLETE DATE
M 79 6350 2404	AUTO MEASUREMENT OF J-INTEGRAL FRACTURE TOUGHNESS THE TEST SPECIMENS HAVE BEEN RECEIVED. THE INITIAL TEST RESULTS INDICATE THE SPECIMEN REPRESENT A WIDE RANGE OF MECH. PROPERTIES OF CANNON COMPONENTS. THE EXISTING X-Y RECORDER FAILED. A REPLACEMENT HAS BEEN ORDERED. SO TEST WILL BE REPEATED.	80.0	22.0	46.0	DEC 80	DEC 80
M 79 6350 2405	BURN TIME TEST FOR ZIRCONIUM POWDER IN THERMAL BATTERY THE REVIEW AND ANALYSIS OF VARIOUS EXISTING OPEN TRAIN BURN TIME TECHNIQUES HAS BEEN COMPLETED. THE DESIRABLE FEATURES ARE BEING INCORPORATED INTO THE NEW SYS. THE AREAS OF CONCENTRATION ARE MEASURING THE ACTUAL BURN TIME AND POWDER PREPARATION.	54.0	11.0	30.0	MAR 80	MAR 80
M 79 6350 2407	LIQUID CHROMATOGRAPHY FOR EPOXY RESIN FORMULATION TEST PROCEDURES FOR MONITORING EPOXY RESIN PREPREGS HAVE BEEN PREPARED AND ARE BEING EVALUATED ON SP250 PREPREGS. ALSO PREPREG SAMPLING PROCEDURES WERE OPTIMIZED AND CRITERIA WERE ESTABLISHED FOR REPRESENTATIVE SAMPLING.	90.0		63.4	MAR 80	MAR 80
M 79 6350 2408	CHEMICAL ANALYSIS OF SILICON NITRIDE THE SILICON NITRIDE SAMPLES WERE EXAMINED FOR YTTRIUM CONTENT BY EMISSION SPECTROSCOPY. SAMPLES CONTAINED 14-16 PERCENT YTTRIUM. SILICON CONTENT WAS CHECKED BY ATOMIC ABSORPTION.	160.0		150.3	MAR 80	MAR 80
M 79 6350 2409	EMISSION SPECTROGRAPH ANAL WARGING STEEL PLASMA EXCIT THE INSTRUMENT VENDOR HAS COMPLETED THE PROFILING OF 40 SLITS AND IS CURRENTLY IN THE PROCESS OF CALIBRATING THE INSTRUMENT. DELIVERY IS SCH. FOR DEC. TO DATE THERE HAVE NOT BEEN ANY MAJOR PROBLEMS.	70.0		67.0	MAY 81	MAY 81
M 79 6350 2410	ULTRASONIC TRANSDUCER EVALUATION INSTRUMENT A SOLE SOURCE CONTRACT WAS AWARDED IN DEC 1979 FOR A PROTOTYPE TRANSDUCER. THE DELIVERY OF THIS TRANSDUCER IS SCHEDULED MARCH 1980.	65.0		23.4	AUG 81	AUG 81
M 79 6350 2412	MODAL ANALYSIS OF STRUCTURES ADDITIONAL CONTRACTORS FOR MODEL ANALYSIS TESTING OF HONEYCOMB PANELS ARE BEING CONSIDERED. THE PROCUREMENT OF TESTING SERVICES IS TAKING MORE TIME THAN ORIGINALLY ANTICIPATED. THE PROJECT COMPLETION DATE HAS BEEN ADJUSTED TO REFLECT THIS DELAY.	52.0		20.1	SEP 80	SEP 80
M 79 6350 2413	TESTING OF TIRES AND ELASTOMERIC PRODUCTS A PAPER, "TIRE INSPECTION", ARMY NEEDS AND REQUIREMENTS, WAS PRESENTED AT A ASTM P-9 SUBCOMMITTEE MEETING. THE PAPER EMPHASIZED THE RELATIONSHIP OF TIRE FAILURES AND RETREADING DIFFICULTIES WITH AR 750-36 TIRE REPLACEMENT RETREAD REQUIREMENT OF 75%					

S U M M A R Y P R O J E C T S T A T U S R E P O R T
 2ND SEMIANNUAL SUBMISSION CY 79 RCS DRCHT-301

ROJ NO.	TITLE + STATUS	AUTHORIZED (8000)	CONTRACT VALUES (8000)	EXPENDED LABOR AND MATERIAL (8000)	ORIGINAL PROJECTED COMPLETE DATE	PRESENT PROJECTED COMPLETE DATE
79 6350 2414	ELECTROTHERMAL ANALOG RESPONSE INSP OF EEO'S THE CONTRACT TO DEVELOP AND CHECKOUT THE APPARATUS WITH NON-EXPLOSIVE DEVICES, THE CONTRACT WAS AMENDED TO INCLUDE EXPLOSIVE DEVICE TESTING. THE EFFORT APPEARS TO BE PROMISING, A PY81 MMT PROJECT P-16 HAS BEEN PREPARED.	85.0	45.0		OCT 80	OCT 80
79 6350 2418	HALF LIFE OF TRITIUM LUMINOUS LAMPS THE SCOPE OF WORK TO STUDY THE "BURN-IN" ACCEPTANCE TECHNIQUE HAS BEEN COMPLETED AND SUBMITTED TO ARADCOM PROCUREMENT. THE 2ND ACCEPTANCE TECHNIQUE, SPECTRAL SHIFT WITH AGE, HAS BEEN OUTLINED AND THE NECESSARY MEASUREMENT EQUIP HAS BEEN ORDERED.	125.0	71.5	26.6	SEP 81	SEP 81
79 6350 2419	OBJECTIVE TECH + INSTR FOR INSPECT OF IR COMPONENTS THE INSTRUMENTATION HAS BEEN TENTATIVELY SELECTED.	60.0			DEC 81	DEC 81
79 6350 2419	OBJECTIVE TECH + INSTR FOR INSPECT OF IR COMPONENTS A PROPOSAL FOR THE APPLICATIONS STUDY IS FORTHCOMING. UPON RECEIPT OF THE PROPOSAL, AN APPLICATION STUDY CONTRACT WILL BE AWARDED.	35.0	25.0	10.0	DEC 81	DEC 81
79 6350 2420	CALIBRATION FOR OPTICAL SCRATCH/DYE STDS FOR FIRE CONT THE INSTRUMENTATION HAS BEEN TENTATIVELY SELECTED.	60.0	13.0	4.2	DEC 80	DEC 80
79 6350 2422	INSPECT/MES METHOD FOR SPHERICAL SURFACED COMPONENTS THE TECHNICAL STUDY, ENGINEERING MODEL AND SOFTWARE DEVELOPMENT SCOPES OF WORK HAVE BEEN COMPLETED. THE MOIRE TECHNIQUE FEASIBILITY STUDY IS NEAR COMPLETION. THE RESULTS AND FINDINGS WILL BE VERIFIED IN JAN 80.	106.7	77.0	15.0	MAR 81	MAR 81
79 6350 2424	AUTOMATIC GEAR TOOTH CONTOUR INSPECTION SYSTEM THE CONTRACT STATEMENT OF WORK HAS BEEN COMPLETED. THE JUSTIFICATION OF AUTHORITY TO NEGOTIATE HAS BEEN COMPLETED AND FORWARDED TO DARCOM.	98.0			MAY 81	MAY 81
79 6350 2425	OPTICAL TESTING OF FAR INFRARED MATERIALS THE TEST SAMPLES FOR THIS PROJECT WERE RECEIVED. ELATIONS WERE MADE WITH RCOs USED BY SIEMENS, WEST GERMANY. THE RESULTS OBTAINED WERE EXCELLENT. THE 2ND GENERATION MEASUREMENT SET-UP IS BEING IMPLEMENTED.	85.0		23.7	SEP 80	SEP 80
79 6350 2426	CRYOGENIC COOLER HELIUM LEAK RATE TEST SET RIGS ARE DUE IN JAN 80. IT IS ANTICIPATED THAT THE CONTRACT WILL BE AWARDED IN FEB 80. THIS PROGRAM SHOULD BE COMPLETED WITHIN ONE YEAR AFTER AWARD. THE CONTRACTOR WILL DEVELOP A PROCEDURE FOR TESTING COMMON MODULE COOLERS.	120.0		10.7	DEC 80	DEC 80

S U M M A R Y P R O J E C T S T A T U S R E P O R T
 MANUFACTURING METHODS AND TECHNOLOGY PROGRAM
 2ND SEMI-ANNUAL SUBMISSION CY 79 RCS ORCMT-301

PROJ NO.	TITLE + STATUS	AUTHORIZED (\$000)	CONTRACT VALUES (\$000)	EXPENDED LABOR AND MATERIAL (\$000)	ORIGINAL PROJECTED COMPLETE DATE	PRESENT PROJECTED COMPLETE DATE
M 79 6350 2427	SYSTEM FOR TESTING SLIDE FASTENERS - ZIPPER SYSTEM THE INSTRUMENTATION MODIFICATIONS WERE COMPLETED. PROCEDURES HAVE BEEN DEVELOPED. FOUR ZIPPERS HAVE BEEN TESTED UNDER VARIOUS LOADS. RESULTS INDICATED SIGNIFICANT DIFFERENCES IN PERFORMANCE AMONG VARIOUS MFG. THE PROJECT IS ON SCHEDULE.	26.2		6.0	APR 80	APR 80
M 79 6350 2428	2-CHANNEL TELEMETRY FOR 3-INCH SPIN AIR GUN RECEIPT OF ALL COMPONENTS HAS BEEN MUCH SLOWER THAN ANTICIPATED. A 5 MONTH DELAY IN THE DELIVERY OF THE TRANSMITTER AND A 3 MONTH DELAY IN THE DELIVERY OF THE 36-PIN PROGRAMMER HAS BEEN EXPERIENCED.	60.0		27.0	MAY 80	MAY 80
M 79 6350 2429	MINI COMPUTER MAPPING AN RFP SOLICITING A COMPUTER CONTROLLED ULTRASONIC FLAW DETECTOR HAS BEEN INITIATED. THREE PROPOSALS WERE RECEIVED, NONE OF THESE PROPOSALS MET THE SPECIFICATION, A 2ND RFP WAS INITIATED. THE PROPOSALS ARE SCHEDULED TO BE SUBMITTED 4 DEC 1979.	53.0		6.1	OCT 80	OCT 80
M 79 6350 2430	ACCEPT TESTER FOR COMMON MODULE SCANNER PERFORMANCE THE CONTRACTOR RESPONSES TO THE RFP WERE RECEIVED 9 NOV 79 AND ARE IN THE PROCESS OF BEING EVALUATED. THE PERFORMANCE PERIOD FOR THE CONTRACT WILL BE ELEVEN MONTHS AND WILL RESULT IN A COMPLETE SET OF TEST EQUIPMENT AND SPECIFICATIONS.	100.0		84.8	SEP 80	SEP 80
M 79 6350 2432	INSPECTION LEAK TEST APPARATUS NO SEMI-ANNUAL STATUS REPORT RECEIVED.					
M 79 6350 2433	POWER SUPPLY TEST CONSOLE FOR 2ND GEN IMAGE INTENSIFIER THE CONTRACTOR PROPOSALS HAVE BEEN EVALUATED. THE LOWEST QUALIFIED BIDDER IS 65K OVER THE ESTIMATE. 26K OF THIS SHORT FALL HAS BEEN OBTAINED. A REQUEST FOR 39K HAS BEEN SUBMITTED TO AMRRC.	159.0		12.0	FEB 80	FEB 80
M 79 6350 2435	DIFFERENTIATION BETWEEN SB253 + SB203 IN PAINT PIGMENTS PROJECT HAS BEEN COMPLETED. IT APPEARS THAT THE METHOD DEVELOPED IS SUSPECT. THE METHOD DETECTS SB253 WHEN THIS UNDESIRABLE PIGMENT IS PRESENT. THIS METHOD WILL BE USED WHEN SB HAS BEEN DETECTED BY X-RAY SPECTROMETRY.			10.0	AUG 79	DEC 79
M 79 6350 2436	ANALYTICAL CHEMICAL METHODS FOR MIL-C-14460 PROCEDURES FOR THE EXTRACTION OF INA.OMETA WERE REVIEWED. A METHOD FOR EXTRACTION AND ESTERIFICATION HAS BEEN ADOPTED. SOME REFINEMENTS ARE REQ. TO SHORTEN AND IMPROVE THE RELIABILITY. UPDATE NO PROBLEMS OF ANY SIGNIFICANCE HAVE BEEN ENCOUNTERED.	40.0		33.1	FEB 80	FEB 80
M 79 6350 2437	DIMENSIONAL INSPECTION FOR PRECISION ELECTROMAGNETIC COMP NO SEMI-ANNUAL STATUS REPORT RECEIVED.					

MANUFACTURING METHODS AND TECHNOLOGY PROGRAM
 S U M M A R Y P R O J E C T S T A T U S R E P O R T
 2ND SEMIANNUAL SUBMISSION CY 79 RCS DREMT-301

PROJ NO.	TITLE + STATUS	AUTHORIZED (8000)	CONTRACT VALUES (8000)	EXPENDED LABOR AND MATERIAL (8000)	ORIGINAL PROJECTED COMPLETE DATE	PRESENT PROJECTED COMPLETE DATE
M 79 6350 2438	HIGH PERF LIQUID CHROMATOGRAPHIC TEST OF AZIRIDINES TO DATE VERY LITTLE PROGRESS HAS BEEN MADE DUE TO THE UNAVAILABILITY OF CRITICAL EXISTING EQUIPMENT AND PERSONNEL. THE PURCHASED EQUIPMENT AND CHEMICALS HAS BEEN RECEIVED, EXISTING PROCEDURE HAS BEEN REVIEWED IN AN EFFORT TO MINIMIZE DUPLICATION.	79.0		14.9	JEC 80	DEC 80
M 79 6350 2439	SPECS FOR COMPOSITE PROPELLANT BINDERS THE DERIVATING AGENT HAS BEEN SELECTED AS 3,5 DINITROBENZOYL CHLORIDE. THE UV RESPONSE WAS CALIBRATED WITH DERIVATES OF UNDECYL ALCOHOL AND VERIFIED WITH CAREFULLY PREPARED SAMPLES OF HTPB-R45M POLYMER.	55.0		15.7	JUN 80	JUN 80
M 79 6350 2440	GAS-LIQUID CHROMATOGRAPHIC TESTING OF MC-BASED PROP THE GAS CHROMATOGRAPH AND LIQUID SAMPLER WERE EVALUATED AND FOUND TO HAVE INSTRUMENTATION PROBLEMS. THE EQUIPMENT WAS RETURNED AND HAS SINCE BEEN RECEIVED IN SATISFACTORY CONDITIONS. THIS HAS DELAYED THE PROJECT APPROX. TWO MONTHS.	85.0	6.7	27.3	SEP 80	SEP 80
M 79 6350 2441	WELD EVALUATION BY ACOUSTIC EMISSION TECHNIQUE THE TECHNICAL DATA PACKAGE HAS BEEN PREPARED. THIS WILL BE A SOLE SOURCE PROCUREMENT. THE CONTRACTOR HAS BEEN SELECTED BUT THE CONTRACT HAS NOT BEEN AWARDED.	125.0			SEP 80	SEP 80
M 79 6350 2444	ULTRASONIC TESTING OF ROADWHEELS THE CONTRACT WAS AWARDED IN SEPTEMBER. THE M40 ROADWHEEL HAS BEEN SELECTED FOR THIS TESTING PROJECT. 10 ROADWHEELS WERE SHIPPED TO THE CONTRACTOR. PRELIMINARY ARRANGEMENTS HAVE BEEN MADE FOR PIGGY-BACK TESTING ON PIP MAGAL TANKS.	55.0	41.5	3.8	SEP 80	SEP 80
M 79 6350 2445	ULTRASONIC TIRE INSPECTION THE ULTRASONIC TDM INSPECTION OF TIRES BEGAN 12 JUN 79. 350 OF THE 1800 TIRES HAVE BEEN INSPECTED AND FIELDED. THE PROJECT WAS DELAYED APPROX. 2.5 MONTHS BY PERSONNEL PROBLEMS.	79.0	65.2		DEC 80	DEC 80
M 79 6350 2446	BLACKLIGHT TV SYSTEM DUE TO A LARGE WORK LOAD THIS PROJECT CAN NOT BE ACCOMPLISHED AS ORIGINALLY PLANNED. IT HAS BEEN DECIDED TO COMBINE THIS PROJECT WITH WHITE LIGHT INSPECTION SYS. THE PROJECT WOULD BE JOINT EFFORT OF AMARC AND WATERVLIET.	30.0		0.6	AUG 80	JUN 82
M 79 6350 2447	AEROSOL TEST APPARATUS FOR BIOLOGICAL DETECT + WARNING THE CONTRACTORS RESPONSES TO THE RFP HAS BEEN EVALUATED. NEGOTIATIONS ARE UNDERWAY TO RESOLVE THE COST DISPARITY. UPON RESOLUTION, THE CONTRACT WILL BE AWARDED.	130.0		12.8	NOV 80	NOV 80

MANUFACTURING METHODS AND TECHNOLOGY PROGRAM
SUMMARY PROJECT STATUS REPORT
2ND SEMI-ANNUAL SUBMISSION CY 79 RCS DRCHT-301

PROJ NO.	TITLE + STATUS	AUTHORIZED (\$000)	CONTRACT VALUES (\$000)	EXPENDED LABOR AND MATERIAL (\$000)	ORIGINAL PROJECTED COMPLETE DATE	PRESENT PROJECTED COMPLETE DATE
M 79 6350 2448	IMPROVED GB SIMULANT A REVIEW OF THE GAS LIFE DATA FROM GB TESTING OF CHARCOAL AND GAS FILTERS HAS BEEN CONDUCTED. A PRELIMINARY SCREENING OF SIMULANT CHEMICALS HAS BEEN PERFORMED. HALOGEN SUBSTITUTED HYDROCARBONS AND LOW MOLECULAR WEIGHT ESTERS APPEARS TO BE BEST SUITED	112.0			DEC 80	FEB 80
M 79 6350 2451	GUN TUBE ROUNDNESS MEASUREMENT A T40 PART SYS IS REQ-(1) TWO-POINT AND THREE POINT BORE MEASUREMENT FIXTURE WHICH ALLOWS SIMULTANEOUS MEASUREMENTS(2) COMPLEX HEAD TO DEFINE THE EXACT PROFILE OF THE TUBE BORE. HEAD ASSY DRAWINGS HAS BEEN COMPLETED, COMPONENTS SELECTED.	65.0	6.0	4.5	SEP 80	SEP 80
M 79 6350 2452	ILLUM OF CANNON TUBE BORE SURFACES FOR VISUAL INSPECT A SYSTEM CONCEPT AND DRAWINGS HAVE BEEN COMPLETED. A RFP FOR THE DESIGN HAS BEEN ADVERTISED. SOME DELAYS HAVE BEEN EXPERIENCED DUE TO M4 BORESCOPE PRIORITY. FOR THE MOST PART, THE PROJECT IS PROGRESSING SATISFACTORILY.	60.0		8.0	SEP 80	SEP 80
M 79 6350 2453	THICKNESS MEASUREMENT OF NON-MAGNETIC COATINGS AFTER INVESTIGATING THICKNESS MEASUREMENT EQUIP. MANUFACTURERS, IT WAS DETERMINED THAT THEY DO NOT OFFER SPECIAL PROBE NOR DO THEY INCORPORATE THEIR EQUIP. INTO MEASUREMENT SYSTEMS. THEREFORE, SOME FIXTURING WILL BE DONE IN HOUSE.	80.0		4.9	DEC 80	DEC 80
M 79 6350 2454	IMPROVEMENT OF BORE EROSION GAGE THE CENTERING MECHANISMS WERE MODIFIED SO THAT GAGE WILL PRODUCE REPRODUCIBLE RESULTS. MEASUREMENTS WERE MADE ON A 105MM M48. THE MEASUREMENT RESULTS PROVED THE MOD. TO BE VERY SUCCESSFUL. THE GAGE IS PLANNED FOR IMMEDIATE SERVICE FOR 105MM M48.	20.0	10.0	2.0	FAM 80	MAY 80
M 79 6350 2455	QUENCH CRACK DETECTION DIFFICULTIES HAVE BEEN EXPERIENCED IN ESTABLISHING AUTOMATED CONCEPTS. THIS HAS RESULTED IN A DELAY IN THE PROCUREMENT OF EQUIPMENT. A CONTRACT FOR DESIGN SUPPORT HAS BEEN INITIATED. THIS WILL ACCELERATE THE EFFORT.	125.0		13.2	DEC 80	DEC 80
M 79 6350 2456	TEST SYSTEM FOR REAL TIME MECHANICAL WEAR ASSESSMENT ARRANGEMENTS HAVE BEEN MADE WITH THE 94TH AVIATION DETACHMENT TO OBTAIN OIL SAMPLES FOR FERROGRAPHIC ANALYSIS. A NUMBER OF UM-1 AND UM-58 HELICOPTER ENGINES, TRANSMISSIONS AND MOTORS ARE ASSIGNED TO THIS PROGRAM. PERIODIC OIL SAMPLES WILL BE TAKEN.	70.0	5.0	55.0	UCT 80	UCT 80
M 80 6350	MATERIALS TESTING TECHNOLOGY THE FUNDING FOR THE PROJECT WAS JUST RELEASED.	4,604.0			APR 83	APR 83

MANUFACTURING METHODS AND TECHNOLOGY PROGRAM
 S U M M A R Y P R O J E C T S T A T U S R E P O R T
 2ND SEMI ANNUAL SUBMISSION CY 79 RCS DRCMT-301

PROJ NO.	TITLE + STATUS	AUTHO- RIZED (8000)	CONTRACT VALUES (8000)	EXPENDED ORIGINAL LABOR AND MATERIAL (8000)	ORIGINAL PROJECTED COMPLETE DATE	PRESENT PROJECTED COMPLETE DATE
M 78 6370	OPTIMIZATION OF MMT PROGRAM EFFECTIVENESS LITERATURE SEARCH COMPLETE. REVISED SURVEY FORM MAILED. INFO REQUESTED FROM MTF. CONTACTED SRE ABOUT ORGANIZING AND CO-SPONSORING A SEMINAR ON RESULTS OF THIS PROJECT.	35.0	33.5		FEB 80	MAY 80
M 79 6390	PROGRAM IMPLEMENTATION AND INFORMATION TRANSFER CONTRACT IS COMPLETE, FINAL REPORT HAS BEEN ACCEPTED. MT TECH NOTES HAVE BEEN PREPARED FOR THE REPORTING PERIOD.	250.0	191.5	12.8	JUN 80	JUN 80
M 80 6390	MMT PROGRAM IMPLEMENTATION AND INFORMATION TRANSFER RECEIVED FUNDS IN DEC 79.	250.0			MAR 81	MAR 81

S U M M A R Y P R O J E C T S T A T U S R E P O R T
 2ND SEMIANNUAL SUBMISSION CY 79 RCS DRCMT-201

PROJ NO.	TITLE + STATUS	AUTHOR- RIZED (\$000)	CONTRACT VALUES (\$000)	EXPENDED		ORIGINAL PROJECTED COMPLETE DATE	PRESENT PROJECTED COMPLETE DATE
				LABOR AND MATERIAL (\$000)	(\$000)		
4 77 5052	ARMY ENGINEERING DESIGN HANDBOOK FOR PRODUCTION SUPPORT FINAL DRAFT MANUSCRIPT COMPLETED ON THE DESIGN GUIDE FOR PRODUCTIBILITY. CONTINUED WORK ON DYNAMICS OF BALLISTIC IMPACT PART 1 + 2, DEVELOPMENT GUIDE FOR RELIABILITY PART 5 AND CONTRACTING FOR RELIABILITY.	383.0	383.0			JUN 78	MAY 81
4 76 5052	ARMY ENG DESIGN HANDBOOKS FOR PRODUCTN SUPPORT COMPLETED WORK ON ARMY WEAPONS SYSTEMS ANALYSIS, PART 2 HANDBOOK,	449.9	449.9			JUN 78	OCT 79
4 77 5052	ARMY ENGINEERING DESIGN HANDBOOK FOR PRODUCTION SUPPORT WORK CONTINUED ON HANDBOOK NO. 706. WITH RECOIL SYSTEMS MANUAL COMPLETED, DIELECTRIC EMBEDDING OF ELECTRICAL OR ELECTRONIC COMPONENTS PUBLISHED AND AN OUTLINE PREPARED ON MAINTAINABILITY GUIDE FOR DESIGN.	305.0	208.0	96.9		SEP 79	JUN 81
0 78 5052	ARMY ENGINEERING DESIGN HANDBOOK FOR PRODUCTION SUPPORT HIGH PRIORITY EFFORT ON NEW HANDBOOKS TO SUPPORT PROGRAM IN MATERIAL DETERIORATION PREVENTION AND CONTROL. MORTAR SYSTEM HANDBOOK EFFORT CANCELLED. RECEIVED ADDITIONAL \$120K FUNDS FOR NEW EFFORT.	670.0	472.0	76.0		NOV 79	JAN 82
0 79 5052	ARMY ENGINEERING DESIGN HANDBOOK FOR PRODUCTION SUPPORT COMPLETED DRAFT REPORT ON DESIGN GUIDANCE FOR PRODUCTIBILITY AND OUTLINE OF MATERIALS ENGINEERING FOR PLASTIC PRODUCT DESIGN.	495.0	387.6	28.3		MAY 83	MAY 83
0 80 5052	ARMY ENGINEERING DESIGN HANDBOOKS FOR PRODUCTION SUPPORT NO ACCOMPLISHMENTS DUE TO LATE RECEIPT OF FUNDS.	460.0				JAN 83	JAN 83

RUBBER HANDWARE



CLOTHING PATTERNS

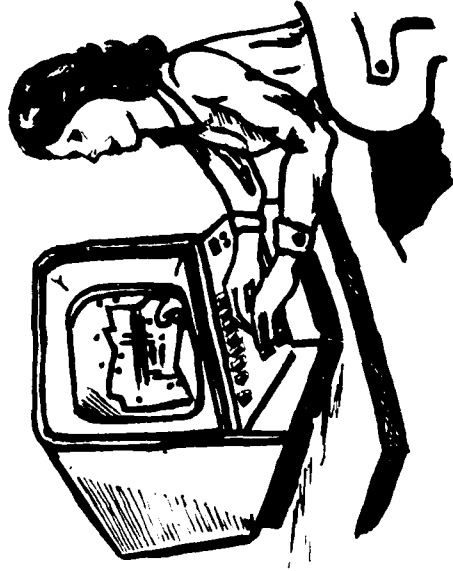

HELMETS

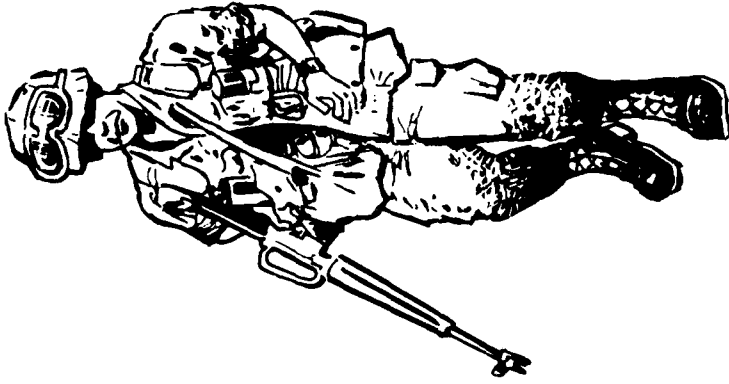

NATICK R&D COMMAND
(NARADCOM)

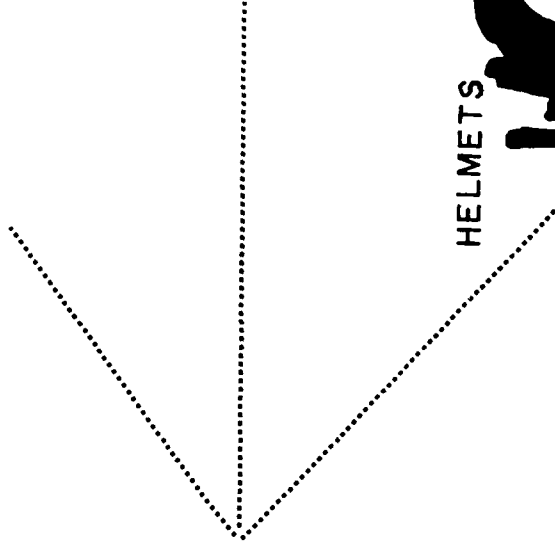

NATICK RESEARCH AND DEVELOPMENT COMMAND
CURRENT FUNDING STATUS, 2ND CY79

FISCAL YEAR	NO. OF PROJECTS	AUTHORIZED FUNDS (\$)	CONTRACT FUNDS ALLOCATED (\$)	CONTRACT FUNDS EXPENDED (\$)	PERCENTAGE (%)	INHOUSE FUNDS REMAINING (\$)	INHOUSE FUNDS EXPENDED (\$)	PERCENTAGE (%)
76	2	527,700	404,800	401,800	(99%)	122,900	122,900	(100%)
77	0	0	0	0	(0%)	0	0	(0%)
77	1	218,500	160,900	146,500	(91%)	57,600	56,500	(98%)
78	0	0	0	0	(0%)	0	0	(0%)
79	2	760,400	726,800	0	(0%)	33,600	26,700	(83%)
80	0	0	0	0	(0%)	0	0	(0%)
81	0	0	0	0	(0%)	0	0	(0%)
82	0	0	0	0	(0%)	0	0	(0%)
TOTAL	5	1,506,600	1,292,500	548,300	(42%)	214,100	208,100	(97%)

AUTHORIZED FUNDING CONTRACT ALLOCATED 86%

INHOUSE REMAINING 14%

MANUFACTURING METHODS AND TECHNOLOGY PROGRAM
 SUMMARY REPORT
 STATUS REPORT
 2ND SEMI-ANNUAL SUBMISSION CY 79 RCS DRG-MT-301

PROJ NO.	TITLE + STATUS	AUTHOR- RIZED (\$000)	CONTRACT VALUES (\$000)	EXPENDED LABOR AND MATERIAL (\$000)	ORIGINAL PROJECTED COMPLETE DATE	PRESENT PROJECTED COMPLETE DATE
7 76 8035	AUTOMATED PRODUCTION OF INSULATED FOOTWEAR THIS PROJECT IS COMPLETE. THE FINAL TECHNICAL REPORTS WILL BE DISTRIBUTED IN THE NEAR FUTURE. BOOTS ARE CURRENTLY BEING TESTED IN ALASKA.	390.0	320.5	69.5	OCT 76	JUL 80
7 76 8036	NUMERICALLY CONTROLLED HELMET DIE STAMPING THIS PROJECT WAS NOT SUCCESSFUL. A REPORT COVERING WORK PERFORMED AT ARRADCOM HAS BEEN DISTRIBUTED. A FINAL TECH REPORT SUMMARIZING THE ENTIRE PROJECT IS BEING PREPARED.	137.7	84.3	53.4	SEP 77	DEC 80
0 77 8053	CADAM OF PARACHUTE HARDWARE NO TAPES HAVE BEEN PREPARED AND TESTED. A COMPUTER PROGRAM HAS BEEN DEVELOPED THAT WILL DESIGN FORGING DIES. THIS TECHNOLOGY GREATLY REDUCES THE ART OF DESIGNING FORGING DIES TO A SCIENCE. THE NEXT STEP IS TO REFINE THE SOFTWARE.	218.5	160.9	56.5	MAR 78	JUN 81
0 79 8063	IMPROVED METHODS OF MFG OF BUTYL RUBBER HANDWEAR TWO CONTRACTS WERE AWARDED. ONE WILL INVESTIGATE INJECTION MOLDING AND FABRICATION OF HOLDS AND SAMPLE ITEMS. THE OTHER WILL INVESTIGATE LATEX DIPPING.	457.7	429.1	28.7	JUN 82	JUN 82
0 79 8066	CONTINUOUS FILAMENT HELMET PREFORM CONTRACT AWARDED JUST BEFORE END OF YEAR. GOVT ACCEPTANCE/REJECTION OF 250 HELMETS WILL OCCUR ON OR BEFORE 30 SEP 80. IT WILL BE BASED ON RANDOM SELECTION AND BALLISTIC TESTING OF FIVE HELMETS.	302.7	297.7		MAR 81	MAR 81

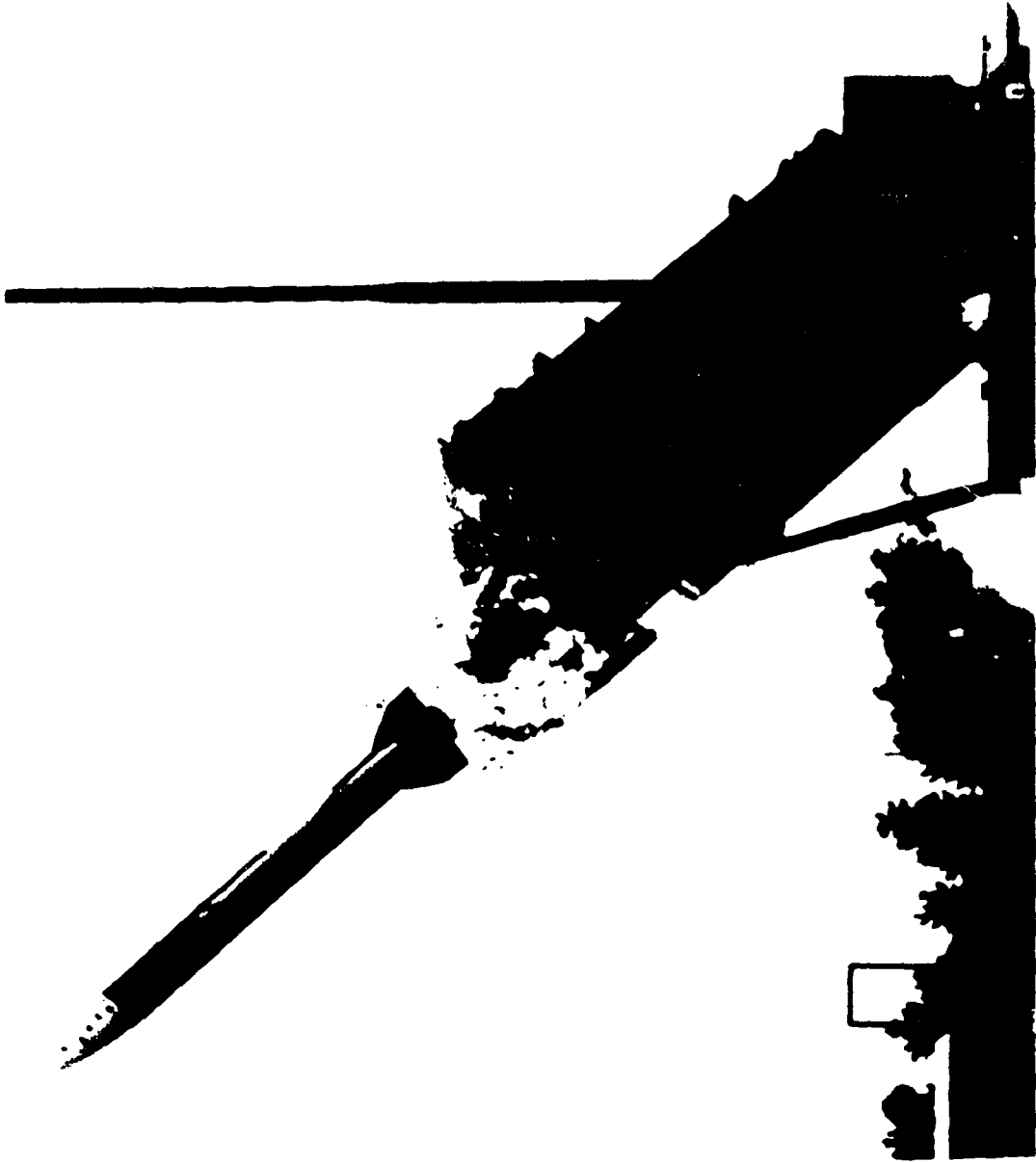

MISSILE COMMAND
(MICOM)

PRECEDING PAGE BLACK-OUT FILLED

M I S S I L E C O M M A N D
CURRENT FUNDING STATUS, 2ND CY79

FISCAL YEAR	NO. OF PROJECTS	AUTHORIZED FUNDS (\$)	CONTRACT ALLOCATED (\$)	CONTRACT FUNDING EXPENDED (\$)	CONTRACT FUNDING EXPENDED (%)	INHOUSE REMAINING (\$)	INHOUSE FUNDING EXPENDED (\$)	INHOUSE FUNDING EXPENDED (%)
76	1	550,000	411,000	399,200	(97%)	139,000	138,800	(99%)
77	0	0	0	0	(0%)	0	0	(0%)
77	6	5,384,000	3,878,900	3,632,100	(93%)	1,505,100	609,000	(40%)
78	23	6,993,300	4,430,400	3,058,600	(69%)	2,562,900	1,831,900	(71%)
79	23	8,830,000	6,114,200	1,755,900	(28%)	2,715,800	1,402,300	(51%)
80	21	7,222,000	0	0	(0%)	7,222,000	0	(0%)
81	0	0	0	0	(0%)	0	0	(0%)
82	0	0	0	0	(0%)	0	0	(0%)
TOTAL	74	28,979,300	14,834,500	8,845,800	(59%)	14,144,800	3,982,000	(28%)

AUTHORIZED FUNDING CONTRACT ALLOCATED 51%

INHOUSE REMAINING 46%

S U M M A R Y P R O J E C T S T A T U S R E P O R T
2ND SEMI-ANNUAL SUBMISSION CY 79 RCS DRCHMT-301

PROJ NO.	TITLE + STATUS	AUTNO- RIZED (8000)	CONTRACT VALUES (8000)	EXPENDED LABOR AND MATERIAL (8000)	ORIGINAL PROJECTED COMPLETE DATE	PRESENT PROJECTED COMPLETE DATE
R 80 1010	IMPROVED MFG. PROCESSES FOR DRY TUNED ACCELEROMETERS (CAM) THIS PROJECT WILL DEVELOP EDM METHODS FOR PRODUCING LOW COST ACCELEROMETERS. A CONTRACT IS BEING PREPARED AND WILL BE AWARDED IN APR 1980.	380.0			MAR 81	MAR 81
R 80 1021	COMPUTERIZED PROD PROCESS PLAN F/MACHINED CYLINDRICAL PARTS THIS EFFORT WILL BE DIRECTED TOWARD DEVELOPING A COMPUTERIZED PROCESS PLANNING SYSTEM. WORK HAS JUST STARTED. THE PROCUREMENT PACKAGE IS BEING PREPARED.	240.0			OCT 82	OCT 82
R 80 1023	DIGITAL FAULT ISOLATION F/HYBRID MICROELECTRONIC MODULES THIS PROJECT WAS JUST FUNDED. NO STATUS REPORT IS REQUIRED.	300.0				
R 80 1024	HMT RADIO FREQUENCY STRIPLINE HYBRID COMPONENTS THIS PROJECT WAS JUST FUNDED. NO STATUS REPORT IS REQUIRED.	400.0				
R 80 1026	LOW COST MANUF TECH F/THE HIGH PROD OF MISSILE VANES THE CONTRACT PACKAGE HAS BEEN COMPLETED AND SUBMITTED TO PROCUREMENT FOR PLACEMENT.	305.0			JUN 81	JUN 81
R 80 1030	AUTO TEST, MOUNTING, + STACKING OF LOCASERT THIS PROJECT WAS JUST FUNDED. NO STATUS REPORT IS REQUIRED.	230.0				
R 79 1041	LSI FABRICATION METHODOLOGY IMPROVEMENT MARTIN MARIETTA IS WORKING ON LSI PREAMPLIFIER TOPOLOGY, PROCESSING, AND TESTING TO OBTAIN YIELD IMPROVEMENT ON 3 COMPETITIVE DESIGNS- HARRIS, RCA, AND MARTIN. ALSO WORKING ON SUM-LIMIT LSI CIRCUIT FOR YIELD IMPROVEMENT. UNITS ARE FOR CLGP + HELLFIRE	1,000.0	997.0	3.0	SEP 80	NOV 80
R 78 3075	INFRARED TESTING OF PC BOARDS AND MICROCIRCUITS A FINAL REPORT HAS BEEN PREPARED AND AN INDUSTRY DEMONSTRATION WAS HELD. INFRARED TESTING WAS FOUND USEFUL FOR TESTING MATCHED TRANSISTORS, PLATED THRU HOLES, HYBRID BONDING, AND FAULT ISOLATION.	335.0	230.7	60.3	AUG 79	NOV 79
R 77 3112	MFG MULTILAYER RIGID-FLEX HARNESS MC DONNELL DOUGLAS FOUND 2 GOOD COMBINATIONS. EPOXY/GLASS BOARD AND B STAGE ADHESIVE WITH POLYIMIDE FLEX MATERIAL, AND POLYIMIDE/GLASS BOARDS AND ACRYLIC ADHESIVE WITH POLYIMIDE FLEX MATERIAL. ALSO USED RF PLASMA ETCHING FOR SNEAR REMOVAL FROM HOLES.	350.0	164.4	183.0	SEP 78	JUN 80
3 77 3115	ENGINEERING FOR METROLOGY AND CALIBRATION SEE SUBTASKS BELOW FOR PROJECT STATUS.	594.0	206.0	369.0	SEP 78	JUN 80

S U M M A R Y P R O J E C T S T A T U S R E P O R T
 2ND SEMIANNUAL SUBMISSION CY 79 RCS DRCHT-301

MANUFACTURING METHODS AND TECHNOLOGY PROGRAM

PROJ NO.	TITLE + STATUS	AUTHO- RIZED VALUES (\$000)	CONTRACT VALUES (\$000)	EXPENDED LABOR AND MATERIAL (\$000)	ORIGINAL PROJECTED COMPLETE DATE	PRESENT PROJECTED COMPLETE DATE
3 77 3115 08	REPEATABILITY STUDY OF LOW FLOW TURBINE METERS SUBTASK IS COMPLETE. WHEN THE FLOWMETER TEST RESULTS WERE ANALYZED ON A COMPOSITE CURVE, THE CURVE FIT VALUES VARIED FROM SLIGHTLY LESS THAN 0.5% OF READING TO VALUES LARGER THAN 5% OF READING.					DEC 79
3 77 3115 09	MODULAR EQUIPMENT CONFIGURATION FOR CALIBRATION ANALYSIS THE MECCA SIGNAL GENERATOR CALIBRATOR IS A LONG LEAD ITEM AND SERIOUSLY BEHIND SCHEDULE DUE TO CONTRACTOR PRODUCTION PROBLEMS. STEPS ARE BEING TAKEN TO SPEED UP DELIVERY. IF THESE STEPS FAIL, THE CONTRACT WILL BE CANCELED.					JUN 80
3 78 3115	ENGINEERING FOR METROLOGY AND CALIBRATION SEE SUBTASKS BELOW FOR PROJECT STATUS.	661.0	234.0	370.0	SEP 79	DEC 80
3 78 3115 07	MICROPROCESSOR TECHNOLOGY SUBTASK IS COMPLETE. WORK WILL BE CONTINUED IN FY79 AND FY80. A PROTOTYPE DIFFERENTIAL AND ABSOLUTE THERMOMETER HAS BEEN TESTED AND USED SATISFACTORILY UNDER VARIOUS OPERATING CONDITIONS. THE PREVIOUSLY USED SOFTWARE HAS BEEN MODIFIED.					DEC 80
3 78 3115 16	TURBINE FLOWMETER DATA HANDLING UNIT FUNCTIONAL TESTING HAS STARTED WITH RUNS MADE IN THE AUTOMATIC MODE AT TWO DIFFERENT VISCOSITIES FOR THE TWO SIZES OF TURBINE METERS. THE PRELIMINARY RESULTS ARE GOOD.					DEC 80
3 78 3115 17	DYNAMIC MEASUREMENT AND STIMULI SUBTASK IS COMPLETE. THIS WORK WILL BE CONTINUED BY PROJECT NO 3 79 3115. THE AN/USM/410 SYSTEM CALIBRATION REQ WERE ESTABLISHED. N89 COMPLETED THE PROTECTIVE CIRCUIT MODIFICATION TO THE DAC CURRENT SOURCES.					DEC 79
3 78 3115 21	ELECTRO-OPTICAL (E=O) AND LASER SYSTEM STANDARDS SUBTASK IS COMPLETE. THE WORK WILL CONTINUE BY PROJECT NO 3 80 3115. ALL THE GOALS WERE ACHIEVED FOR THE CO2 LASER OPTICAL ATTENUATOR/REFLECTANCE STD, PROTOTYPE LASER TRANSCIEVER CALIBRATOR, AND NEAR MILLIMETER WAVE FREE FIELD POWER ENERGY STANDARD.					DEC 79
3 79 3115	ENGINEERING FOR METROLOGY AND CALIBRATION SEE SUBTASKS BELOW FOR PROJECT STATUS.	693.0		526.0	SEP 80	SEP 80
3 79 3115 01	JOSEPHSON EFFECT VOLTAGE STANDARD NOISE PROBLEMS HAVE BEEN ENCOUNTERED FROM THE MICROWAVE SOURCE. BAD SOLDER CONNECTION MAYBE THE CAUSE OF THIS PROBLEM. THIS WILL BE FURTHER INVESTIGATED WHEN THE REMAINING SYSTEMS ARE PUT INTO OPERATION DURING THE 1ST QUARTER 1980.				SEP 80	SEP 80

SUMMARY PROJECT STATUS REPORT
 2ND SEMI-ANNUAL SUBMISSION CY 79 RCS DRCHMT-301

MANUFACTURING METHODS AND TECHNOLOGY PROGRAM

PROJ NO.	TITLE + STATUS	AUTHORIZED	CONTRACT VALUES	EXPENDED LABOR AND MATERIAL (\$000)	ORIGINAL PROJECTED COMPLETE DATE	PRESENT PROJECTED COMPLETE DATE
3 79 3115 03	LOW FREQUENCY RMS VOLTMETER HARDWARE, PROTOTYPE INSTR. HAVE BEEN FAB. AND TESTED. SOFTWARE HAS BEEN WRITTEN AND TESTED FOR THE AUTO-RANGE FUNCTION. A FORMAL OPERATING HANDBOOK HAS BEEN WRITTEN INCLUDING PARTS LISTS, SCHEMATICS, THEORY, AND OPERATING INSTRUCTIONS.	(8000)	(8000)	(8000)	SEP 80	JAN 80
3 79 3115 04	AUTOMATIC AC/DC THERMAL VOLTAGE MEASUREMENT SYSTEM HARDWARE, SOFTWARE AND INTERFACE PROBLEMS HAVE BEEN ENCOUNTERED. EVEN THOUGH THESE PROBLEMS ARE SEVERE, IT IS FELT THAT THEY CAN BE OVERCOME OR ALTERNATE COURSES ARE AVAILABLE. USE OF A DUAL GAIN PROGRAMMABLE AMPLIFIER IS BEING CONSIDERED.				SEP 80	SEP 80
3 79 3115 14	SIX-PORT MEASUREMENT SYSTEM THE SIX-PORT NETWORKS WERE DELIVERED TO NBS IN DEC, FOUR MO. BEHIND SCHEDULE. COMPUTER PROGRAMS HAVE BEEN WRITTEN FOR TESTING THE NETWORKS. A REG. TEMP.-CONTROLLED HOUSING FOR TESTING THE NETWORKS IS BEING FABRICATED.				SEP 80	SEP 80
3 79 3115 17	DYNAMIC ELECTRICAL MEASUREMENTS AND STANDARDS ANALOG COMPARATOR COMPONENTS STABILITY AND ACCURACY CHARACTERISTICS WERE EVALUATED.					SEP 80
3 79 3115 18	BAROMETRIC PRESSURE MEASUREMENT CALIBRATION AND DETERMINATION OF THE ULTIMATE SENSITIVITY OF THE MEASURING SYSTEM HAS BEEN COMPLETED. A SURVEY OF LOCATIONS IS BEING CONDUCTED TO DETERMINE THE REG. BEFORE THE MEASUREMENT SYSTEM TECHNIQUES ARE FINALIZED.				SEP 80	SEP 80
3 79 3115 19	MILLIMETER WAVE STANDARDS THE MICROCALORIMETER EVALUATION HAS NOT BEEN COMPLETED DUE TO A SIGNAL-SOURCE FAILURE. THE MILLIMETER WAVE SIX-PORT INTEGRATED NETWORKS WERE RECEIVED BY NBS FOR TESTING LATE IN THIS REPORTING PERIOD.				SEP 80	SEP 80
3 79 3115 20	OPTICAL COMMUNICATION SYSTEM STANDARDS DELIVERY OF THE CRITICAL SYS COMPONENTS FOR THE INITIAL OPTICAL FIBER MEASUREMENT HAS BEEN DELAYED UNTIL 2ND QTR, FY80.				SEP 80	SEP 80
3 79 3115 21	ELECTRO-OPTICAL (E/O) AND LASER SYSTEM STANDARDS CO2 OPTICAL ATTENUATOR INITIAL CALIBRATION OF THE SPUN-AL INTEGRATING SPHERE WAS ACCOMPLISHED. PROTOTYPE LASER TRANSCIEVER CALIBRATOR'S CONTRACT AWARD IS SCH FOR 15 FEB, WITH DELIVERY IN SEP.					SEP 80
3 79 3115 22	PHYSICAL MEASUREMENTS * /TRANSDUCER AND *MICROPROCESSOR ASSEMBLY LANGUAGE PROGRAMMING OF THE PRESSURE CALIBRATION SYS. CONTINUED, WITH MOST WORK BEING DONE ON THE SYSTEM TO MEASURE RATE-OF-CLIMB. A MODIFICATION TO PERMIT AIR SPEED MEASUREMENTS WILL BE PROGRAMMED IN THE FUTURE.					SEP 80

MANUFACTURING METHODS AND TECHNOLOGY PROGRAM
 SUMMARY PROJECT STATUS REPORT
 2ND SEMIANNUAL SUBMISSION CY 79 RCS DRCMT-301

PROJ NO.	TITLE + STATUS	AUTHORIZED	CONTRACT VALUES	EXPENDED LABOR AND MATERIAL	ORIGINAL PROJECTED COMPLETE DATE	PRESENT PROJECTED COMPLETE DATE
		(8000)	(8000)	(8000)		
3 79 3115 23	CONTROL TECHNOLOGY THE MODEM HARDWARE IS OPERATIONAL. THE MULTIPLE REMOTE WORKSTATIONS TIED TO A PROCESS CONTROL SYSTEM HAS PROVEN TO BE EFFECTIVE WITH VIRTUALLY NO DEGRADATION IN THE OPERATION OF THE HARDWARE. THE PRINTER ARE SCH. FOR DELIVERY 1 FEB 80.	747.0				SEP 80
3 80 3115	ENGINEERING FOR METROLOGY AND CALIBRATION THIS PROJECT WAS JUST FUNDED. NO STATUS REPORT IS REQUIRED.					
R 79 3116	ROSETTE AIR DEFENSE SEEKER OPTICS AND DETECTORS GENERAL DYNAMICS INITIATED FABRICATION OF LONG LEAD ITEMS INCLUDING PRIMARY MIRRORS AND ALL DETECTOR PARTS. WILL VALIDATE THEIR PRODUCTION, TEST, AND ALIGNMENT METHODS. WILL ALSO FABRICATE AND TEST SIX ROSETTE SCAN SEEKERS AND VALIDATE PERFORMANCE.	750.0	639.6	19.0	SEP 79	OCT 80
R 78 3121	APPLICATION AND NOT OF LINE PIPE FOR MOTOR COMPONENTS THE PROJECT HAS BEEN EXTENDED 10 MOS DUE TO THE DIFFICULTY IN OBTAINING THE "WELD PIPE. THE PIPE HAS BEEN RECEIVED AND THE PROJECT IS ON THE NEW SCHEDULE.	300.0	239.3	55.0	SEP 79	MAY 80
R 78 3126	PROCESSING OF LASER OPTICAL CERAMICS AMRC USED ITS IMPROVED TEMP GRADIENT FURNACE TO GROW NEDDINIUM DOPED YAG. BUT IT WAS NOT LASER QUALITY + WAS LACED WITH SECOND PHASE INCLUSIONS AND SUFFERED FROM GROWTH INTERFACE BREAKDOWN. SCALE-UP FROM 7 TO 10 CM WAS NOT ATTEMPTED. NOT LASER QUALITY.	122.0		122.0	AUG 79	MAR 80
R 78 3133	LITHIUM FERRITE PHASE SHIFTER FOR PHASED ARRAY RADAR RAYTHEON USED TUNGSTEN CARBIDE PINS, ACCURATELY BLENDED CERAMIC PRETRIMMED IN ITS GREEN STATE, AND WELL CONTROLLED FIRING TEMPERATURES TO MAKE LITHIUM FERRITE TOROIDS. TIGHT PROCESS CONTROL AND ACCURATE GRINDING GAVE UNIFORM WALL THICKNESS. GOOD 301.	315.0	208.3	66.6	SEP 79	JUN 80
R 77 3135	PROCESS DEVELOPMENT FOR CARBORANE MANUFACTURE EQUIPMENT AND PROCESS DEBUGGING WAS INITIATED IN JUN 79. PROB WITH TEFLON SEALS WERE CORRECTED. EXPANSION BELLOWS IN THE B10 REACTOR HAD TO BE REPLACED. INITIAL RUNS ARE SCHEDULED FOR JAN/FEB 80. WITH A DEMONSTRATION PLANNED FOR MARCH 80.	2,000.0	2,000.0		SEP 78	JUL 80
R 79 3136	IMPROVED PER PROCESSES FOR COMPLIANT BEARING GYRO SAME AS THE LAST REPORT PERIOD EXCEPT ONE GYRO WAS SUCCESSFULLY TEST FIRED.	350.0	289.5	24.5	JUL 80	MAY 80

MANUFACTURING METHODS AND TECHNOLOGY PROGRAM
 S U M M A R Y P R O J E C T S T A T U S R E P O R T
 2ND SEMI-ANNUAL SUBMISSION CY 79 RCB DRCMT-301

PROJ NO.	TITLE + STATUS	AUTOM- RIZED (8000)	CONTRACT VALUES (8000)	EXPENDED LABOR AND MATERIAL (8000)	ORIGINAL PROJECTED COMPLETE DATE	PRESENT PROJECTED COMPLETE DATE
R 80 3139	PROD METHODS F/MILLIMETER SEEK F/TERMINAL HOVMING APPLICATION THIS PROJECT WAS JUST FUNDED, NO STATUS REPORT IS REQUIRED.	415.0				
R 79 3142	PRODUCTION METHODS FOR LOW COST PAPER MOTOR COMPONENTS RAR MATL AND PAPER STRIP PREPARATION STUDIES CARRIED OUT, PAPER DIRECTIONALITY, WIDTH, THICKNESS, STRENGTH LEVEL AND EDGE PREPARATION LOOKED INTO. STUDY OF AUTO STRIP WINDING AND ADHESIVE APPLICATION OPERATION BEGUN.	275.0	242.8	15.0	JUL 80	JUL 80
R 80 3142	PRODUCTION METHODS F/LOW COST PAPER MOTOR COMPONENTS THIS IS THE 2ND YEAR EFFORT OF A 2-YEAR PROJECT. IT WILL BE CARRIED OUT AS AN OPTION TO THE BASIC CONTRACT. WORK WILL BEGIN IN AUGUST, 1980.	200.0			JUN 82	JUN 82
R 79 3146	HIGH DENSITY MULTILAYER THICK FILM HYBRID MICRO CIRCUITS MICROELECTRONICS ENGR CORP IS EVALUATING MATERIALS AND PROCESSES FOR MAKING FINE LINE HIGH DENSITY MULTILAYER HYBRID CIRCUITS. PROJECT IS AIMING FOR 3 MIL LINES AND 3 MIL SPACES IN GENERAL AND 1 MIL LINES AND 1MIL SPACES AT THE LEAD-INS TO IC PADS.	350.0	240.0	22.3	JUN 80	JAN 81
R 78 3147	ADDITIVE PROCESSES FOR FABRICATION OF PRINT CIRCUIT BOARDS INVESTIGATION OF ELECTROLESS COPPER BATHS, SELECTION OF LAMINATES, AND SCREENING OF PHOTORESIST MATERIALS WAS CONDUCTED.	250.0	170.1	79.9	JUN 78	SEP 80
R 78 3150	DEVEL METHOD FOR UTILIZING UV CURED CONFORMAL COATINGS THE THREE CANDIDATE MATERIALS HAVE BEEN REDUCED TWO. ONE CANDIDATE MATERIAL HAS PASSED ALL OF THE TESTS AND THE OTHER IS UNDERGOING HUMIDITY TESTING. A NO-COST TIME EXTENSION HAS BEEN REQUESTED TO ALLOW THE TESTING OF ADDITIONAL MATERIALS.	126.0	79.4	46.5	SEP 78	JAN 80
R 79 3160	CLEANLINESS + PROCESS CRITERIA FOR CIRCUIT BOARDS FOLLOW ON TO ABOVE. MARTIN WILL DEVISE A MEANS TO IDENTIFY, QUANTIFY AND REMOVE CONTAMINANTS REMAINING ON PCBs AFTER PROCESSING AND NORMAN CLEANING. MARTIN EXPECTS TO IDENTIFY CONTAMINANTS IN CONCENTRATIONS BELOW 100 PARTS PER MILLION.	150.0	89.3	3.1	MAR 80	MAR 80
R 78 3165	PRODY PROCESS + TECHNIQUES FOR SEALING HYBRID MIC-CIR PACK THE FINE LEAK TEST APPARATUS WAS NEARLY COMPLETED. TWO MICROCIRCUIT CAROUSELS WERE COMPLETED. A NEW GROSS LEAK TESTING CONCEPT WAS INVESTIGATED. THE CUSTOM DRY BOX SYSTEM WAS RECEIVED AND INSTALLED AT MICOM.	220.0	211.0	9.0	NOV 79	OCT 80
R 78 3167	PRCO CONTROLS TO PREVENT PLATED-THROUGH HOLE CRACKING HUGHES IS EVALUATING SEL-REX, HARSHAK, AND PYROPHOSPHATE COPPER PLATING BATHS. 18 EPOXY AND 18 POLYIMIDE MULTILAYER BOARD COUPONS ARE TESTED FROM EACH DAY'S RUNS. MINIMUM ANALYSIS IS NEEDED TO MAINTAIN THE BATHS. DUPONT'S COR-LAM ALSO BEING TESTED.	223.0	114.1	107.6	MAR 79	MAR 81

SUMMARY PROJECT STATUS REPORT
 2ND SEMI-ANNUAL SUBMISSION CY 79 RCS DRCHT-301

PROJ NO.	TITLE + STATUS	AUTHORIZED (\$000)	CONTRACT VALUES (\$000)	EXPANDED LABOR AND MATERIAL (\$000)	ORIGINAL PROJECTED COMPLETE DATE	PRESENT PROJECTED COMPLETE DATE
R 77 3169	AUTO OPTICAL INSPECTION OF PC BOARDS AND COMPONENTS (CAM). A ONE YEAR EXTENSION IS REQ TO COMPLETE THIS PROJECT. THE PROTOTYPE IS IN THE FINAL STAGES OF ASSEMBLY. THE CONTRACTOR PLAN TO IMPLEMENT THIS SYS IN THEIR FACILITIES AND MARKET THE SYSTEM COMMERCIALY.	275.0	268.6	6.4	SEP 78	DEC 80
R 78 3171	AUTO MONITOR AND CONTROL FOR WAVE SOLDERING MACHINES. WASHINGTON IS DESIGNING MICROPROCESSOR CONTROLLED SYSTEM TO MON TURE, SOLDER WAVE HEIGHT, CLEANING SOLUTION TEMP. AND FLUX QUANTITY. ALL SOUND ALARMS IF PRE-SET LIMITS ARE EXCEEDED.	450.3	355.1	94.6	SEP 80	JUL 80
R 77 3183	IMPROVED PROCESSES FOR INERTIAL GRADE G-FLEX ACCELEROMETER SUNSTRAND ESTABLISHED PROCEDURES TO PRODUCE INERTIAL GRADE ACCELEROMETERS AT IMPROVED YIELD WITH VERY STABLE BIAS CHARACTERISTICS AND REDUCED COST. THE SAMPLES WERE USED FOR DIAGNOSTIC TESTS ON LANCE G-FLEX ACCELEROMETER QUALIFICATION PROGRAM.	165.0	114.4	50.6	DEC 78	MAR 80
R 78 3183	IMPROVED PROCESSES FOR INERTIAL GRADE G-FLEX ACCELEROMETER SUNSTRAND BUILT TWO TYPES OF ACCELEROMETERS WITH INVAR EXCITATION RINGS. BOTH HAD LOWER THERMAL HYSTERESIS THAN THE STANDARD G-FLEX DESIGN. A THIRD TYPE IS BEING CONSTRUCTED. MYSOL PC-17 SEALING MATERIAL IS BEING INVESTIGATED.	180.0	115.6	64.4	JUL 80	SEP 80
R 80 3188	IMPROVED MFG PROCESSES FOR INFRARED INDIRECT FIRE SEEKERS THIS PROJECT WAS JUST FUNDED. NO STATUS REPORT IS REQUIRED.	500.0				
R 78 3188	INFRARED IMAGING SEEKERS FOR THERMAL HOMING MISSILES TEXAS INSTRUMENTS PRODUCED TEN SEEKER HEADS USING TECHNIQUES DETERMINED DURING EARLIER EFFORTS. SEEKERS MET ALL SPECS AND WERE DELIVERED TO MICOM. TECHNICAL REPORTS WERE DELIVERED TO DDC. TI ISSUED CONFIDENTIAL REPORT. IS A CONTINUATION OF R773188.	500.0	449.9	25.0	MAR 79	JUN 80
R 79 3204	INTERNAL SHEAR FORMING OF MISSILE STRUCTURES NO WORK REPORTED FOR THIS SEMI-ANNUAL PERIOD.	200.0	150.1	25.1	SEP 80	SEP 80
R 79 3217	AUTOMATED PRODUCTION METHODS FOR TRAVELING WAVE TUBES LITTON BUILT AND TESTED 8 TUBES. SEVERAL WERE ACCEPTED. PILOT LINE WILL BE RUN TO BUILD 20 TUBES FROM 26 LR FEWER STARTS. TUBES MUST PASS 300 FAST START TEST AND 300 HOUR LIFE TEST. SOME TUBES WERE MADE WITH LOWER COST PARTS, SAVING \$600 PER TUBE.	740.0	564.9	125.0	JUL 80	SEP 80
R 78 3218	REDUCE THE FINISHING COST OF FUSED SILICA RADOMES FOUR ADDITIONAL RADOMES (15 TOTAL) WERE CAST. TWO WERE DAMAGED BY THE LOSS OF INTERNAL SEALS DURING CASTING. THE SEALING SYSTEM WAS UPGRADED. TWO CASTINGS WERE MADE SATISFACTORILY. PROBLEMS DURING SINTERING SUGGESTED IMPROVEMENTS TO KILN CONTROLS.	300.0	12.7	281.7	OCT 79	

MANUFACTURING METHODS AND TECHNOLOGY PROGRAM
SUMMARY PROJECT STATUS REPORT
2ND SEMIANNUAL SUBMISSION CY 79 RCS DRCHT-301

PROJ NO.	TITLE + STATUS	AUTHORIZED VALUES (8000)	CONTRACT VALUES (8000)	EXPENDED ORIGINAL LABOR AND MATERIAL (8000)	PROJECTED COMPLETE DATE	PRESENT PROJECTED COMPLETE DATE
R 79 3219	AUTOMATIC POLYMER ATTACHMENT PRODUCTION METHODS A CONTRACT HAS BEEN AWARDED FOR DEVELOPMENT OF BONDING OF CHIPS.	200.0	140.0	60.0	AUG 79	SEP 80
R 80 3219	AUTOMATIC POLYMER ATTACHMENT PRODUCTION METHODS THIS PROJECT WAS JUST FUNDED. NO STATUS REPORT IS REQUIRED.	200.0				
3 76 3227	LOW COST PROD METH FOR HAND HYBRID CHIP W/TAPE CAR LEAD FR SEE SUBTASKS A-D BELOW. AN OPTION II FOR \$22K IS EXPECTED TO BE SIGNED BY 15 MARCH. HONEYWELL WILL BUILD 75 SYNCHRONOUS COUNTER CIRCUITS FOR USE IN THE B-52, DDA COST STUDY, AND RUN A DEMONSTRATION. 1 YEAR IS ALLOWED TO COMPLETE THIS EFFORT.	550.0	411.0	138.8	NOV 77	FEB 81
3 76 3227 A	HONEYWELL WORK HONEYWELL COMPLETED THIS CONTRACT.	200.0	149.9	50.1		JUN 80
3 76 3227 B	DETEX SYSTEMS WORK DETEX SYSTEMS WORK IS COMPLETED. THEY DEVELOPED UTILIZATION TECHNIQUES.	43.0	32.0	11.0		OCT 79
3 76 3227 C	HONEYWELL MODIFICATION HONEYWELL MODIFICATION. THE FIRM ACCUMULATED COST DATA. RCA STOPPED SUPPLYING WAFERS OF THE TYPE NEEDED TO COMPLETE THE CIRCUITS SPECIFIED BY THE CONTRACT. WORK WAS TERMINATED ON THIS PORTION.	72.4	54.1	18.3		OCT 79
3 76 3227 D	HONEYWELL OPTION HONEYWELL OPTION. HONEYWELL PREVIOUSLY RELEASED PROCESS SPECS FOR WAFER METALLIZATION, SUBSTRATE WFR, TAPE CARRIER WFR, DIE SEPARATION, INNER LEAD BONDING, OUTER LEAD BONDING, DIE-ON-TAPE TESTING, AND REMARK. THIS PORTION IS COMPLETE.	234.6	175.0	59.6		JUN 80
R 78 3229	METHODOLOGY FOR PRODUCING LOW COST/ DISPOSABLE MANDELS A SET OF MANDELS WAS MADE. SIX BEST MANDELS WERE CHOSEN AND LOADED INTO CASES SUPPLIED UNDER THE LOW COST INTEGRATED MOTOR PROGRAM. ONE MOTOR WAS STATIC TESTED AND THE IGNITION AND MANDEL EXTRUSION PHASE WENT WELL. A FINAL REPORT WAS DRAFTED.	150.0	44.9	72.2	SEP 79	JUN 80
R 78 3242	DIGITAL FAULT ISOLATION OF PRINTED CIRCUIT BOARD HUGHES AIRCRAFT SURVEYED INDUSTRY CIRCUIT BOARD BUILDERS TO DETERMINE BOARD TESTABILITY AND TESTER FEATURES. THEY USED THE DATA AND WROTE A "TEST ENGINEER'S CHECKLIST FOR TESTABILITY". MARTIN ISSUED AN INTERIM REPORT IN AUG 79.	425.0	277.6	146.1	SEP 79	JUN 80
R 79 3242	DIGITAL FAULT ISOLATION OF PRINTED CIRCUIT BOARD HUGHES AIRCRAFT WROTE A TEST SYSTEM SPEC BASED ON TEST SYSTEM CAPABILITY DATA OBTAINED FROM INDUSTRY ON A QUESTIONNAIRE CIRCULATED WITH PREVIOUS PROJECT FUNDS. A TESTER WAS ORDERED. SIGNATURE ANALYSIS TESTING OF MICROPROCESSORS WAS CONTEMPLATED.	425.0	425.0		APR 80	JUL 80

SUMMARY PROJECT STATUS REPORT
 2ND SEMIANNUAL SUBMISSION CY 79 RCB DRCMT-301

PROJ NO.	TITLE + STATUS	AUTHORIZED (8000)	CONTRACT VALUES (8000)	EXPENDED LABOR AND MATERIAL (8000)	ORIGINAL PROJECTED COMPLETE DATE	PRESENT PROJECTED COMPLETE DATE
R 78 3253	HIGH CURRENT DENSITY CATHODES SPERRY USED PLASMA ETCH TO FORM A DEEP EMITTER STRUCTURE + A RAISED GATE GRID-LIKE STRUCTURE OF MOLY ON A SILICON DIOXIDE WAFER. PLASMA ETCH GAVE 1.5 MICRON HOLES USING STANDARD SEMICONDUCTOR TECHNIQUES. ELECTRON BEAM LITHOGRAPHY ALSO USED. WORK COMPL	175.0	124.7	50.3	JUN 80	DEC 79
R 79 3253	HIGH CURRENT DENSITY CATHODES SPERRY UNIVAC IS REPLACING WET CHEMICAL ETCHING WITH DRY GAS ETCHING TO REDUCE CATHODE OUTGASSING. PLASMA ETCHING ALSO REDUCED UNDERCUTTING AND IMPROVES ADHESION OF SILICON DIOXIDE TO MOLY CATHODES. ALSO USED ELECTRON BEAM LITHOGRAPHY FOR PATTERN GEN	175.0	124.3	31.7	JUN 80	NOV 80
R 76 3254	SEMI-FLEXIBLE THIN FILM SEMICONDUCTORS MICROELECTRONICS ENGR CORP IS DESIGNING A THIN FILM FACILITY FOR COMPUTER CONTROLLED PROCESSING OF THIN FILM CIRCUITRY. THE APPARATUS MUST BE ABLE TO DEPOSIT CONDUCTOR, RESISTORS AND TRANSISTORS ON SEMI-FLEXIBLE FILMS. HISTORY SHOWS THIS IS VERY RISKY.	400.0	321.7	3.3	JUN 79	SEP 80
R 80 3254	LOW COST SEMI-FLEXIBLE THIN FILM SEMICONDUCTORS (CAM) THIS PROJECT WAS JUST FUNDED. NO STATUS REPORT IS REQUIRED.	315.0				
R 80 3263	PRINTED WIRE BOARDS UTILIZING LEADLESS COMPONENTS THIS PROJECT WAS JUST FUNDED. NO STATUS REPORT IS REQUIRED.	250.0				
R 79 3268	AUTOMATIC CONTROL OF PLATING (CAM) AN AUTOMATIC PWB PLATING LINE SENSING AND CONTROL SYSTEM HAS BEEN DEVELOPED. A PHASE II TESTING OF ALL CRITICAL SOLUTIONS AND IMPLEMENTATION OF THE INVENTORY CONTROL SYSTEM HAS BEGUN.	450.0	209.5	240.5	SEP 80	SEP 80
R 79 3272	FLEX PRINTED CIRCUITS WITH INTEGRAL MOLDED CONNECTORS WESTINGHOUSE IS ESTABLISHING PROCESSES TO FABRICATE FLEXIBLE PRINTED CIRCUITS WITH MOLDED CONNECTORS. 5 WORKING PROTOTYPES OF CONNECTORS WERE MOLDED. FIRST TOOLING WAS PREPARED FOR WELDING. KAPTON INSULATION REMOVED BY CO2 LASER IN AN INERT ATMOSPHERE.	217.0	193.6	15.0	OCT 81	JUL 80
R 79 3280	ENGR ANALYSIS OF MFG PARAMETERS FOR THERMAL BATTERIES TECHNICAL REQUIREMENTS WERE SUBMITTED TO LEGAL FOR APPROVAL. APPROVAL GRANTED 21 JAN 80. PLAN FOR CONTRACT AWARD SECOND QUARTER 1980.	145.0			SEP 80	JUN 81
R 80 3280	MANUFACTURING PARAMETERS FOR THERMAL BATTERIES THIS PROJECT WAS JUST FUNDED. NO STATUS REPORT IS REQUIRED.	340.0				

MANUFACTURING METHODS AND TECHNOLOGY PROGRAM
 S U M M A R Y P R O J E C T S T A T U S R E P O R T
 2ND SEMI-ANNUAL SUBMISSION CY 79 RCS DRCHT-301

PROJ NO.	TITLE + STATUS	AUTHO- RIZED (8000)	CONTRACT VALUES (8000)	EXPENDED ORIGINAL LARGER AND MATERIAL (8000)	ORIGINAL PROJECTED COMPLETE DATE	PRESENT PROJECTED COMPLETE DATE
R 79 3287	PRODUCTION METHODS FOR LOW COST STRIP LAMINATE MOTOR CASES FULL SCALE MOTOR CONCEPT DEMONSTRATED. REPRODUCIBILITY DEMONSTRATION WITH PRODUCTION CONTRACTOR MADE. DELIVERY OF PRODUCTION COMPONENTS FOR TEST FIRING BEGUN.	250.0	198.8	43.0	APR 80	APR 80
R 80 3294	PRODUCTION PROCESSES FOR ROTARY ROLL FORMING CONTRACTOR TO BE SELECTED. PROCUREMENT PACKAGE DELIVERED TO PROCUREMENT DIRECTORATE IN DECEMBER, 1979.	600.0			DEC 81	DEC 81
R 79 3372	MANUFACTURING METHODS FOR MAGNETIC MATERIALS THREE METHODS OF ENCAPSULATING TRANSFORMERS- TRANSFER MOLDING, INJECTION MOLDING, AND LIQUID INJECTION MOLDING (LIM) HAVE BEEN INVESTIGATED. THE LIM METHOD SEEMS MOST PROMISING DUE TO THE PRESSURE INVOLVED.	610.0	520.0		OCT 79	APR 81
R 78 3376	TESTING ELECTRO-OPTICAL COMPONENTS AND SUBSYSTEMS PRELIMINARY ANALYSIS INDICATED THAT THE THROUGHPUT LIMITATIONS AND PHASE MEASUREMENT COMPLICATIONS MAYBE IMPROVED BY COMBINING THE TECH USED FOR PROCESSING RADAR SIGNAL DATA WITH LINEAR SCANNING. THIS WILL PROVIDE RAPID CHARACTERIZATION OF DEFECTS.	375.0	174.3	16.0	DEC 80	JUL 80
R 79 3381	LOW COST, IMPROVED 2-D HEAT SHIELDS A DESIGN UTILIZING 5 ENDS PER CARRIER WITH A 45 DEGREE BRAID ANGLE HAS BEEN CHOSEN AND FABRICATED. PROCESS SPECIFICATIONS ARE BEING ESTABLISHED.	500.0	384.0		MAR 80	DEC 81
R 78 3396	INJECTION MOLDING OF ONE PIECE NOZZLES A CONTRACT WAS AWARDED ON 19 JUNE 1979. PHASE 1 WORK WAS COMPLETED, AND RESULTED IN THE SELECTION OF A CARBON FILLED PHENOLIC COMPOSITE OF THE 25 THERMOSETTING AND THERMOPLASTIC COMPOSITES TESTED.	180.0	157.2	6.0	MAR 80	FEB 80
R 80 3396	INJECTION MOLDING OF LOW COST-ONE PIECE NOZZLES FUNDS WERE RECEIVED IN MID-DECEMBER 79.	180.0				
R 79 3410	PRODUCTION METHOD FOR HEAT PIPES FOR HYBRID/LSI HUGHES IS FABRICATING HEAT PIPES FOR HYBRID LSI CIRCUITS. A VACUUM SYSTEM WILL BE USED FOR EVACUATION, FILL AND SEAL. TEST FIXTURES WERE COMPLETED. THERMAL AND PROCESSING TESTS, AND POWDER WICK FORMING METHODS WERE INITIATED.	250.0	208.9	6.1	SEP 79	JUN 81
R 80 3411	MFG OF NON PLANAR PRINTED CIRCUIT BOARDS THIS PROJECT HAS JUST FUNDED. NO STATUS REPORT IS REQUIRED.	220.0				
R 80 3435	SIMPLIFICATION OF HIGH-POWER THICK FILM HYBRIDS THIS PROJECT HAS JUST FUNDED. NO STATUS REPORT IS REQUIRED.	350.0				

MANUFACTURING METHODS AND TECHNOLOGY PROGRAM
 S U M M A R Y P R O J E C T S T A T U S R E P O R T
 2ND SEMIANNUAL SUBMISSION CY 79 RCS DRCHT-301

PROJ NO.	TITLE + STATUS	AUTHOR RIZED	CONTRACT VALUES	EXPENDED LABOR AND MATERIAL	ORIGINAL PROJECTED COMPLETE DATE	PRESENT PROJECTED COMPLETE DATE
R 78 3436	DEVELOPMENT OF CERAMIC CIRCUIT BOARDS AND LARGE AREA HYBRIDS GENERAL DYNAMICS-PROBLEMS WITH INNER LEAD BONDING + HERMETIC SEALING ARE HAMPERING THE PROGRAM. MARTIN-MARIETTA-PROCUREMENT LEAD TIMES ARE CAUSING PROGRAM DELAYS. BOTH CONTRACTORS HAVE REQUESTED A NO-COST EXTENSION OF THE CONTRACTS.	325.0	271.6	53.1	DEC 79	OCT 79
R 80 3436	CERAMIC CIRCUIT BOARDS + LARGE AREA HYBRIDS THIS PROJECT WAS JUST FUNDED. NO STATUS REPORT IS REQUIRED.	450.0				
R 79 3438	DELIDDING, PARALLEL SEAM SEALED HYBRID MICROELECT PACKAGES EIGHT PROPOSALS WERE EVALUATED. CONTRACTOR WILL ESTABLISH COST EFFECTIVE TECHNIQUES FOR DELIDDING AND RESEALING PARALLEL SEAM SEALED HYBRID MICROELECT PACKAGES. A MESA DIAMOND LAP WILL BE USED FOR DELIDDING.	200.0		25.0	OCT 79	JUL 81
R 78 3440	PRODUCTION TESTING OF CONTROL SYSTEMS FOR GUIDED WEAPONS A COMPUTER SYSTEM TRADE-OFF STUDY WAS CONDUCTED. THE COPPERHEAD CONTROL SECTION TEST REQ CHANGED ADDING TEST THAT WILL EFFECT BOTH THE COST AND DELIVERY OF THIS EQUIPMENT.	550.0	490.4	47.5	APR 80	MAY 80
R 79 3441	APPLICATION OF HIGH ENERGY LASER MANUFACTURING PROCESSES ALL WORK EXCEPT COST ANALYSIS AND FINAL REPORT IS COMPLETED.	400.0	200.0	192.0	SEP 79	MAR 80
R 79 3444	FULLY ADDITIVE MANUFACTURING FOR PRINTED WIRING BOARDS THE PROGRAM HAS BEEN DELAYED DUE TO A FIRE THAT DESTROYED THE PLATING LINE AT THE CONTRACTOR'S FACILITY. THE PLATING LINE HAS BEEN RECONSTRUCTED AND EFFORT IS UNDERWAY TO GET THE PROGRAM BACK ON SCHEDULE.	200.0	120.0	26.0	SEP 79	SEP 80
R 80 3444	FULLY ADDITIVE MANUFACTURING FOR PRINTED WIRING BOARDS THIS PROJECT WAS JUST FUNDED. NO STATUS REPORT IS REQUIRED.	200.0				
R 79 3445	PRECISION MACHINING OF OPTICAL COMPONENT ASSEMBLY AND TABULATION OF DATA ON INFRARED OPTICS HAS BEGUN. THIS DATA IS BEING EXAMINED FOR COMPONENTS AMENABLE TO DIAMOND TURNING. SELECTION AGAINST CONVENTIONAL METHODS IS BEING MADE ON A COST-PERFORMANCE BASIS.	300.0	176.9		OCT 81	OCT 81
R 80 3445	PRECISION MACHINING OF OPTICAL COMPONENTS THIS PROJECT WAS JUST FUNDED. NO STATUS REPORT IS REQUIRED.	400.0				
R 77 3452	LOW COST QUANTITY PRODUCTION TECHNIQUES FOR LASER SEEKERS MARTIN MARIETTA BUILT TOOLING TO INTEGRATE THE ALTERNATE MELLFIRE HEAD WITH COPPERHEAD ELECTRONICS PACKAG. HAD PROBLEMS WITH G-SENSITIVE DRIFT, GUIDANCE NOISE AND COLLIMATION OF ROTOR AND ASPHERIC MIRROR. A PILOT LINE WAS ASSEMBLED.	2,000.0	1,125.5		SEP 79	SEP 79

MANUFACTURING METHODS AND TECHNOLOGY PROGRAM
 SUMMARY REPORT
 2ND SEMI-ANNUAL SUBMISSION CY 79 RCS DRCHT-301

PROJ NO.	TITLE + STATUS	AUTHORIZED (\$000)	CONTRACT VALUES (\$000)	EXPENDED LABOR AND MATERIAL (\$000)	ORIGINAL PROJECTED COMPLETE DATE	PRESENT PROJECTED COMPLETE DATE
R 78 3453	GROUND LASER LOCATOR DESIGNATOR PRODUCTION IMPROVEMENTS NAVAL WPNs CTR AT CHINA LAKE WILL ESTABLISH ECONOMICAL PRODUCTION METHODS FOR THE LASER OPTICAL TRAIN AND COMPONENTS IN THE GROUND LASER DESIGNATOR. LENS CLEANLINESS IS NOW A PRODUCTION PROBLEM. FUNDS WERE WIPED TO NWC, CHINA LAKE.	211.0			DEC 80	MAR 81
R 78 3454	LO COST - HI VOLUME RADIOGRAPHIC INSPECTION THE IMAGE PROCESSOR WHICH IS SCHEDULED FOR DELIVERY IN DEC 79 IS 4 MONTHS OVER DUE. ALL THE SOFTWARE HAS BEEN MODIFIED TO OPERATE ON THE PRIME 500 COMPUTER. REVISION TO THE ROLAND INSPECTION PLAN HAS BEEN REVIEWED TO ASSURE IMPLEMENTATION.	200.0	147.6	52.4	FEB 80	JUN 80

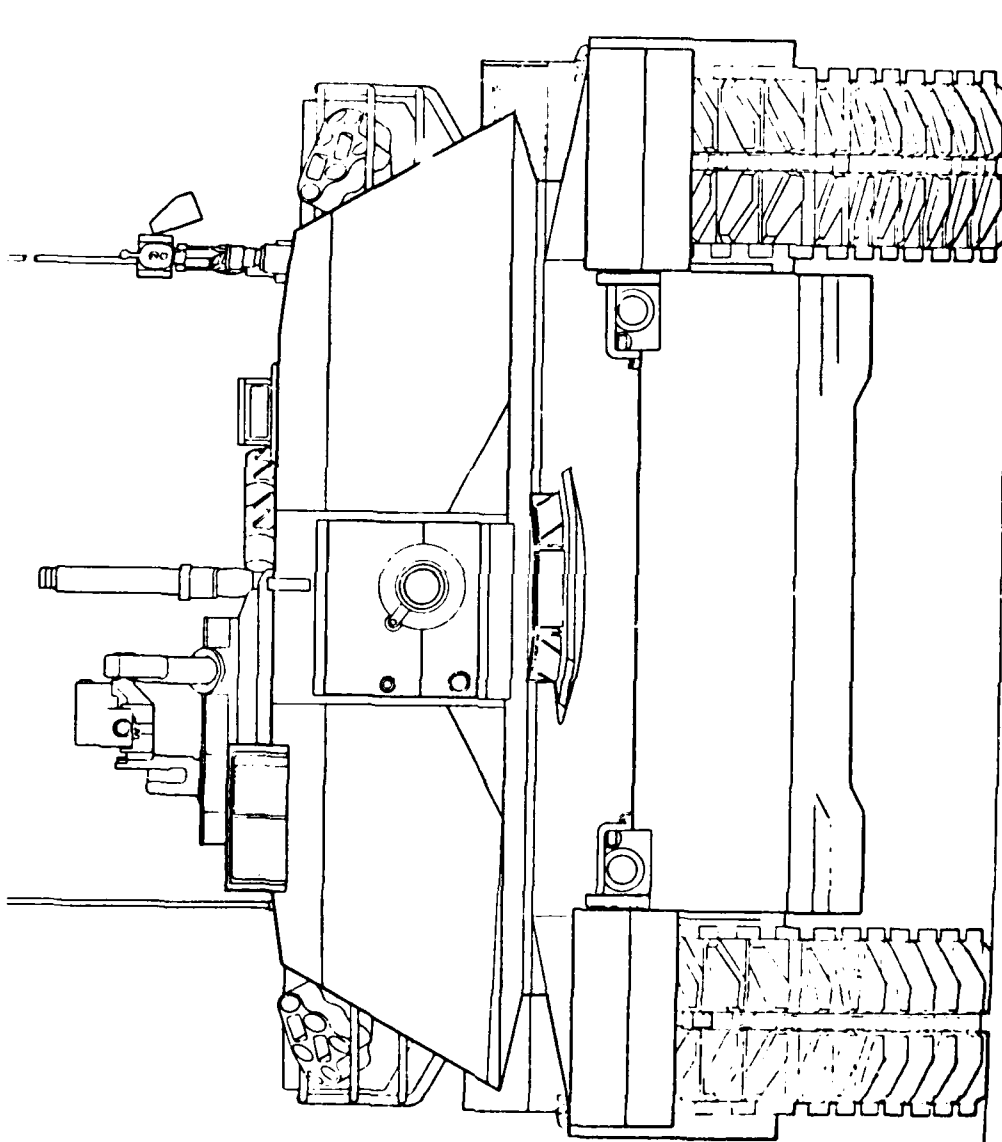

TANK-AUTOMOTIVE R&D COMMAND
(TARADCOM)

TANK-AUTOMOTIVE MATERIEL READINESS COMMAND
(TARCOM)

TANK-AUTO R+D COMMAND AND TANK-AUTO MATERIEL READINESS COMMAND
 CURRENT FUNDING STATUS, 2ND CY79

FISCAL YEAR	NO. OF PROJECTS	AUTHORIZED FUNDS (\$)	* ALLOCATED (\$)	* CONTRACT FUNDING EXPENDED (\$)	* REMAINING (\$)	* INHOUSE FUNDING EXPENDED (\$)
76	2	450,000	127,000	104,000 (61%)	323,000	200,000 (61%)
77	1	500,000	473,400	311,500 (65%)	26,600	26,600 (100%)
77	3	1,150,000	967,000	534,000 (55%)	163,000	166,000 (101%)
78	9	4,442,000	3,152,700	1,287,700 (40%)	1,289,300	464,300 (36%)
79	19	5,104,000	2,170,800	535,000 (24%)	2,933,200	354,900 (12%)
80	19	5,572,000	0	0 (0%)	5,572,000	2,000 (0%)
81	0	0	0	0 (0%)	0	0 (0%)
82	0	0	0	0 (0%)	0	0 (0%)
TOTAL	53	17,218,000	6,890,900	2,772,200 (40%)	10,327,100	1,233,600 (11%)

AUTHORIZED FUNDING CONTRACT ALLOCATED 40% INHOUSE REMAINING 59%

S U M M A R Y P R O J E C T S T A T U S R E P O R T
 2ND SEMI-ANNUAL SUBMISSION CY 79 RCS DRGMT-301

PROJ NO.	TITLE + STATUS	AUTHORIZED (\$000)	CONTRACT VALUES (\$000)	EXPENDED LABOR AND MATERIAL (\$000)	ORIGINAL PROJECTED COMPLETE DATE	PRESENT PROJECTED COMPLETE DATE
T 78 4264	TRACK INSERTS AND FILLERS FOR TRACK RUBBER PADS M103A2 TEST BED VEHICLE AND SUPPORT PARTS OLVD. A TOTAL OF 950 MILES ACCUMULATED ON PAVED TEST COURSE. TEST EQUIPMENT TO SUPPORT PAD THERMAL FATIGUE PROPERTY EVALUATION HAS BEEN ORDERED. TRACK RUBBER SPEC MIL-T-11891 NOW BEING CHANGED.	520.0	197.3	159.3	JAN 81	FEB 81
T 80 4264	TRACK INSERTS AND FILLERS FOR TRACK RUBBER PADS (PHASE II) THIS PROJECT WAS JUST FUNDED. NO STATUS REPORT IS REQUIRED.	125.0				
T 79 4389	POW OF FOLDABLE PLASTIC TOPS FOR SDPT TOP TRUCK CABS-PH 1 USATRODC WAS QUERIED RELATIVE TO EXISTING/FUTURE REQTS FOR FOLDABLE CAB TOPS FOR WHEELED TACTICAL VEHICLES. INFO RECD INDICATED SUCH CONFIGURATION UNDESIRABLE. HENCE THIS PROG WILL BE TERMINATED AND AVAILABLE FUNDS REPROGRAMMED TO HIGHER PRIORITIES.	225.0	30.0	30.0	SEP 81	JAN 80
T 80 4389	PROD OF FOLDABLE PLASTIC TOPS FOR SDPT TOP TRUCK CABS THIS PROJECT WAS JUST FUNDED. NO STATUS REPORT IS REQUIRED.	150.0				
4 76 4392	JOINING DISSIMILAR METALS-PHASE 2- BALLISTIC SAMPLES ARE COMPLETE BUT PROJECT WAS EXHAUSTED FUNDING. ADDITIONAL FUNDS ARE BEING SOUGHT TO COVER BALLISTIC TESTS AND EVALUATION AND FINAL REPORT.	125.0	125.0	125.0	SEP 77	DEC 79
4 76 4563	ROTATIONAL MOLDING OF LARGE CAPACITY FUEL TANKS. CONTRACTOR COULD NOT MAKE SERVICEABLE M88 FUEL TANKS, HENCE NO TESTING YET. CONTRACTOR REMAKING THEM, ALL M551 FUEL TANKS RETURNED TO CONTRACTOR FOR AIR VENT INSTALLATIONS, FUNDS EXPIRED 30 SEPT 79 AND MUST BE RE-JUSTIFIED.	325.0	127.0	75.0	JUN 77	SEP 80
T 79 4575	LASER WELDING TECHNIQUES FOR MILITARY VEHICLES WORK HAS STARTED ON OPTIMIZATION OF PARAMETERS DEVELOPED IN PHASE 1. LIAISON IS ESTABLISHED WITH CHRYSLER TO ASSURE COORDINATION WITH XM1.	375.0	280.1	14.0	JUL 81	FEB 81
T 79 4586	IMPROVED LARGE ARMOR STEEL CASTINGS- PHASE 1 DUAL CONTRACTS WERE AWARDED ROCKWELL AND BLAW-KNOX. EACH WAS MADE AND TESTED THEIR FIRST PARTS, AND SHIPPED TO APG. TWO ROCKWELL PLATES HAVE BEEN BALLISTICALLY TESTED. ONLY ONE SHOWED BALLISTIC IMPROVEMENT, MATERIAL DIFFERENCES BEING STUDIED.	900.0	422.7	39.0	OCT 80	APR 81
T 80 4586	IMPROVED LARGE ARMOR STEEL CASTING (PHASE 2) THIS PROJECT WAS JUST FUNDED. NO STATUS REPORT IS REQUIRED.	1,160.0				
T 79 5002	FABRICATING TORSION SPRINGS FROM HIGH STRENGTH STEELS FMC IS IN THE PROCESS OF DEVELOPING AN UNSOLICITED PROPOSAL.	150.0		26.0	FEB 81	JUN 81

MANUFACTURING METHODS AND TECHNOLOGY PROGRAM
 SUMMARY PROJECT STATUS REPORT
 2ND SEMIANNUAL SUBMISSION CY 79 RGS DRCHT-301

PROJ NO.	TITLE + STATUS	AUTHO- RIZED (8000)	CONTRACT VALUES (8000)	EXPENDED LABOR AND MATERIAL (8000)	ORIGINAL	PRESENT
					PROJECTED COMPLETE DATE	PROJECTED COMPLETE DATE
T 80 5002	MFG METHODS FOR FABRICATING TORSION BAR SPRINGS FROM STEEL THIS PROJECT WAS JUST FUNDED. NO STATUS REPORT IS REQUIRED.	275.0				
T 79 5006	PRODUCTION OF LIGHTWEIGHT STEEL CAST TRACK SHOES MOLD DESIGNS AND PATTERNS ARE COMPLETE. CASTING IS UNDERWAY WITH TEN CASTINGS COMPLETED.	200.0			APR 80	JUN 80
T 80 5006	PRODUCTION OF LIGHTWEIGHT STEEL CAST TRACK SHOES PHASE 2 WORK HAS NOT BEGUN. WORK IS PROCEEDING UNDER PHASE 1. THE FUNDS AUTHORIZED HAVE BEEN REDUCED BY 198,000 DOLLARS. THE US	150.0			DEC 80	DEC 80
T 79 5007	ADVANCED TECHNOLOGY BRAKE LINING MATERIALS-PHASE 2 9 UN SCHEDULE.	190.0	137.0	10.0	JUN 81	JUN 81
T 80 5007	ADVANCED TECHNOLOGY BRAKE LINING MATERIALS (PHASE II) THIS PROJECT WAS JUST FUNDED. NO STATUS REPORT IS REQUIRED.	190.0				
T 77 5014	IMPROVED FOUNDRY CASTINGS UTILIZING CAM WORK ON THE FLUID FLOW SIMULATION HAS BEGUN. INSTRUMENTATION FOR THE CASTING TESTS HAS BEEN DEBugged, AND TESTS ARE IN PROGRESS.	560.0	490.0	70.0	SEP 79	OCT 80
T 78 5014	IMPROVED FOUNDRY CASTINGS UTILIZING CAM WORK ON THE FLUID FLOW SIMULATION HAS BEGUN. INSTRUMENTATION FOR THE CASTING TESTS HAS BEEN DEBugged, AND TESTS ARE IN PROGRESS.	415.0	195.5	15.0	JAN 81	MAR 82
4 78 5019	PLASTIC CONTAINER FOR LOW MAINTENANCE DRY CHARGED BATTERY EARLY BATTERY LEAKAGE PROBLEMS REQUIRED PROTOTYPE MODIFICATIONS. MODIFIED SAMPLES RESUBMITTED TO CTCR AND YPG FOR CONTINUED FIELD EVALUATION. TESTING NOW IN PROGRESS. ALSO EVALUATION OF PROTOTYPE PERFORMANCE IS IN PROGRESS.	160.0		70.0	SEP 79	JUL 80
T 80 5019	STORAGE BATTERY, LOW MAINTENANCE-PHASE III THIS PROJECT WAS JUST FUNDED. NO STATUS REPORT IS REQUIRED.	290.0				
T 78 5024	CAM GEAR DIE DESIGN AND MANUFACTURING PHASE I. THIS STATUS REPORT WAS SENT BACK TO THE COMMAND FOR CORRECTION OF FUNDING. IT WAS NOT BEEN RETURNED.	200.0	112.7		JUN 80	JAN 82
T 79 5024	GEAR DESIGN WFG UTILIZING COMPUTER TECHNOLOGY, CAM-PH2 THIS STATUS REPORT WAS SENT BACK TO THE COMMAND FOR CORRECTION OF FUNDING. IT WAS NOT BEEN RETURNED.	205.0	160.0	14.0	JUN 80	JAN 82
T 79 5045	SPALL SUPPRESSIVE ARMOR FOR COMBAT VEHICLES-PHASE I A SOLE SOURCE PROCUREMENT REQUEST WAS WRITTEN AND ISSUED. A PROPOSAL WAS RECEIVED AND EVALUATED. NEGOTIATIONS WITH THE CONTRACTOR ARE IN THEIR FINAL PHASE.	150.0	92.0	9.0	DEC 79	FEB 81

S U M M A R Y P R O J E C T S T A T U S R E P O R T
 2ND SEMI-ANNUAL SUBMISSION CY 79 RCS DRCHT-301

MANUFACTURING METHODS AND TECHNOLOGY PROGRAM

PROJ NO.	TITLE + STATUS	AUTHORIZED (\$000)	CONTRACT VALUES (\$000)	EXPENDED LABOR AND MATERIAL (\$000)	ORIGINAL PROJECTED COMPLETE DATE	PRESENT PROJECTED COMPLETE DATE
T 80 5045	SPALL SUPPRESSIVE ARMOR FOR COMBAT VEHICLES (PHASE II) A SOLE SOURCE PROCUREMENT REQUEST WAS WRITTEN AND ISSUED. A PROPOSAL WAS RECEIVED AND EVALUATED. NEGOTIATIONS WITH THE CONTRACTOR ARE IN THEIR FINAL PHASE.	190.0			NOV 81	NOV 81
T 79 5054	LASER SURFACE HARDENED COMBAT VEHICLE COMPONENTS=PHASE 1 CONTRACTOR HAS SELECTED THE FIRST COMPONENTS TO BE LASER HEAT TREATED. HEAT TREAT IS TO BEGIN IN JANUARY 1980.	175.0	103.0	3.0	JUL 80	UCT 80
T 80 5054	LASER SURFACE HARDENED COMBAT VEHICLE COMPONENTS (PHASE 2) PROJECT JUST FUNDED.	175.0			JUN 81	JUN 81
T 79 5064	LIGHT WEIGHT SADDLE TANK=PHASE 2 5-TON FUEL TANK TRIAL INSTALLATION COMPLETED AT TECOM TEST SITES. FEASIBILITY TESTING NOW IN PROGRESS. 2.5 TON FUEL TANKS MUST BE REDESIGNED TO ACCOMMODATE EXISTING 2.5 TON CARGO VEHICLES. TESTING RESCHEDULED FOR APRIL 1980.	140.0		55.0	FEB 81	SEP 81
T 79 5067	PLASTIC BATTERY BOX PR ADVERTISED TWICE FOR SOLICITATION. ONE WAS NON-RESPONSIVE TO THE RFP AND THE OTHER WAS 400 PCT OF INDEP GOVT COST EST. REGMT FOR NEW PR IS NOW BEING RECONSTRUCTED FOR SOLE SOURCE NEGOTIATIONS. EXTENSION OF PROJECT THRU FY81 REQUESTED.	60.0		15.0	UCT 79	SEP 81
T 80 5067	PLASTIC BATTERY BOX (PHASE II) THIS PROJECT WAS JUST FUNDED. NO STATUS REPORT IS REQUIRED.	60.0				
T 80 5068	NEW ANTI-CORROSIVE MATERIALS AND TECHNIQUES (PHASE 1) THIS PROJECT WAS JUST FUNDED. NO STATUS REPORT IS REQUIRED.	200.0				
T 80 5075	MILITARY ELASTOMERS FOR TRACK VEHICLES (PHASE 1) THIS PROJECT WAS JUST FUNDED. NO STATUS REPORT IS REQUIRED.	200.0				
T 79 5080	HIGH STRENGTH NEAR NET SHAPE ALUMINUM TRANSMISSION CASES THIS STATUS REPORT WAS SENT BACK TO THE COMMAND FOR CORRECTION OF FUNDING AND ACCOMPLISHMENTS. IT HAS NOT BEEN RETURNED.	325.0		34.0	JUL 81	SEP 82
T 80 5080	FABRICATION METHODS FOR ALUMINUM TRANSMISSION CASES THIS STATUS REPORT WAS SENT BACK TO THE COMMAND FOR CORRECTION OF FUNDING AND ACCOMPLISHMENTS. IT HAS NOT BEEN RETURNED.	150.0			MAR 84	MAR 84
T 80 5081	FABRICATION OF FRICTION RINGS AND REACTION PLATES THIS PROJECT WAS JUST FUNDED. NO STATUS REPORT IS REQUIRED.	210.0				
T 79 5082	FLEXIBLE MACHINING SYSTEMS PILOT LINE FOR TCV COMPONENTS A SIGNIFICANT EFFORT HAS BEEN EXPENDED IN IDENTIFYING AND GUIDING POTENTIAL NEW USERS OF THE TECHNOLOGY.	440.0	395.0	12.0	MAR 80	MAR 80

MANUFACTURING METHODS AND TECHNOLOGY PROGRAM
 SUMMARY PROJECT STATUS REPORT
 2ND SEMIANNUAL SUBMISSION CY 79 HCS DRGCMT-301

PROJ NO.	TITLE + STATUS	AUTO- RIZED (\$000)	CONTRACT VALUES (\$000)	EXPENDED LABOR AND MATERIAL (\$000)	ORIGINAL PROJECTED COMPLETE DATE	PRESENT PROJECTED COMPLETE DATE
T 80 5082	FLEXIBLE MACHINING SYSTEM, PILOT LINE FOR TCV COMPONENTS THE PHASE II CONTRACT IS BEING NEGOTIATED, SEE PHASE I-MMT PROJECT T 79 5082.	800.0		2.0		
T 77 5083	UPSCALING OF POWDERED METALLURGY PROCESSES THE DIE BLOCK WAS CHANGED TO ACCEPT EIGHT CARTRIDGE HEATERS INSTEAD OF FOUR, TRIAL RUN OF ISOTHERMAL FORGING OF SPUR GEARS WAS MADE.	215.0	152.0	66.0	MAY 79	NOV 80
T 78 5083	UPSCALING OF POWDERED METALLURGY PROCESSES A DIE WITH CHANGEABLE INSERTS TO ACCOMMODATE DIFFERENT GEARS IS BEING DESIGNED AS A COST SAVING MEASURE.	293.0	179.0	96.0	MAR 79	SEP 81
T 79 5083	UPSCALING OF ADVANCED POWDERED METALLURGY PROCESSES-PH 3 PHASES 1 AND 2 TEST GEARS ARE SCHEDULED FOR COMPLETION MARCH 31, 1980. PHASE 3 VEHICLE TESTING WILL THEN BEGIN.	175.0	105.0	7.0	MAR 81	MAR 81
T 78 5085	PRODUCTION TECHNIQUES FOR FABRICATION OF TURBINE RECUPERATOR THERMOPHYSICAL PROPERTIES OF EQUIPMENT MALFUNCTIONS IN THE POWER SUPPLY AND MIRROR SYSTEM, THE EQUIPMENT WAS RETURNED TO ENGLAND FOR REPAIR AND IT APPEARS REPAIR HAS BEEN ACHIEVED.	485.0	448.0	15.0	JAN 80	OCT 81
T 79 5088	HIGH POWER ELECTRON BEAM WELDING IN AIR PHASE 1 RFP FAILED TO GENERATE INTEREST DUE TO PRESENT STATE OF THE ART. THE FUNDS AUTHORIZED HAVE BEEN REDUCED BY 198,000 DOLLARS. THE USE OF REMAINING FUNDS IS BEING REVIEWED.	55.0		17.0	SEP 80	JUN 80
T 80 5088	HIGH POWER ELECTRON BEAM WELDING IN AIR (PHASE 2) THIS PROJECT WAS JUST FUNDED. NO STATUS REPORT IS REQUIRED.	250.0				
T 79 5090	IMPROVED AND COST EFFECTIVE MACHINING TECHNOLOGY METCHO HAS ESTABLISHED CONTACT WITH SMI PMO AND IS PREPARING TO DEVELOP SOLUTIONS FOR CRITICAL MACHINING PROBLEMS WHICH ARE ALREADY KNOWN.	340.0	326.0	2.5	FEB 81	MAY 81
T 80 5090	IMPROVED AND COST EFFECTIVE MACHINING TECHNOLOGY (PHASE 2) THIS PROJECT WAS JUST FUNDED. NO STATUS REPORT IS REQUIRED.	289.0				
T 79 5094	ARMOR STEEL TREATED WITH RARE EARTH ADDITIONS A RFP WAS ISSUED ON 3 SEPARATE OCCASIONS WITH NO RESPONSE. MAYELLE HAS LEARNED OF THE PROJECT TOO LATE TO PREPARE A FORMAL RESPONSE TO THE RFP AND IS IN THE PROCESS OF PREPARING AN ALTERNATIVE PROPOSAL.	480.0		16.0	SEP 80	MAY 81
T 77 5097	INTERMEDIATE CAST LOW COST COMPRESSOR PHASE I HAS BEEN SUCCESSFULLY COMPLETED. THE FINAL REPORT FOR PHASE I WILL BE SUBMITTED AT THE END OF PHASE 2.	375.0	325.0	50.0	JUN 79	OCT 82

MANUFACTURING METHODS AND TECHNOLOGY PROGRAM
 S U M M A R Y P R O J E C T S T A T U S R E P O R T
 2ND SEMI-ANNUAL SUBMISSION CY 79 RCS DRCMT-301

PROJ NO.	TITLE + STATUS	AUTO- RISED VALUES (\$000)	CONTRACT VALUES (\$000)	EXPENDED ORIGINAL		PRESENT		
				LABOR AND MATERIAL (\$000)	PROJECTED COMPLETE DATE	PROJECTED COMPLETE DATE	PROJECTED COMPLETE DATE	
T 78 5097	INTEGRALLY CAST LOW COST COMPRESSOR (PHASE II) INITIAL CASTING EVALUATION HAS BEEN STARTED BY THE CONTRACTOR AVCO LYCOMING PLANS TO SUBCONTACT FIRST AND SECOND STAGE CASTING. SCHEDULE HAS BEEN CHANGED TO REFLECT CHANGES IN DETAILS.	342.0	287.0	55.0	JUN 80	55.0	JUN 80	SEP 81
T 79 6000	LIGHT WEIGHT TILT-UP HOOD FENDER ASSEMBLY-PHASE I CONTRACT LET TO DETERMINE MATERIALS AND BUILD PROTOTYPE TOOLING FOR PRELIM BUILD-UP TO DETERMINE PROBLEMS WITH FULL SCALE PRODUCTION. IN NOV CONFIGURATION CHANGED TO 5-TON TRUCK SINCE NO 2. 5-TON TRUCKS WILL BE PROCURED OR AVAILABLE FOR TEST.	200.0	150.0	16.0	SEP 81	16.0	SEP 81	SEP 81
T 80 6000	LIGHT WEIGHT TILT-UP HOOD FENDER ASSEMBLY (PHASE II) THIS PROJECT WAS JUST FUNDED. NO STATUS REPORT IS REQUIRED.	350.0						
T 78 6023	FABRICATION OF FLAT THIN GAGE ALLOY STEEL PLATE THE ORIGINAL CONTRACT PRODUCED FLATNESS TOLERANCES WITHIN PROGRAM OBJECTIVES. A SUPPLEMENTAL CONTRACT WAS AWARDED FOR A SIMILAR EFFORT WITH HIGHER HARDNESS PLATES. THIS IS 10 PERCENT COMPLETE.	195.0	123.2	54.0	OCT 79	54.0	OCT 79	SEP 80
T 80 6028	PRODUCTION QUALITY CONTROL BY AUTOMATED INSPECTION EQUIPMENT THIS PROJECT WAS JUST FUNDED. NO STATUS REPORT IS REQUIRED.	278.0						
T 78 6035	ESTABLISH ON-LINE NOT FOR TRACKED COMBAT VEHICLES (PHASE I) THIS PROJECT IS 57% COMPLETE COMPARED TO THE SCHEDULED 65%. OF THE 12 TASKS, ONE HAS BEEN COMPLETED, 3 ARE ON SCHEDULE, 6 ARE BEHIND SCHEDULE. THE EVALUATION OF AUTOMATIC ULTRASONIC SYSTEM IS THE FARTHEST BEHIND SCHEDULE, 18 WEEKS.	1,832.0	1,630.0		APR 81		APR 81	APR 81
T 79 6038	HIGH DEPOSITION WELDING CONTRACT BEING NEGOTIATED.	319.0		33.0	JUL 80		JUL 80	DEC 81

MANUFACTURING METHODS AND TECHNOLOGY PROGRAM
 SUMMARY PROJECT STATUS REPORT
 2ND SEMI-ANNUAL SUBMISSION CY 79 R8 DRMT-301

PROJ NO.	TITLE + STATUS	AUTHORIZED	CONTRACT VALUES (\$000)	EXPENDED LABOR AND MATERIAL (\$000)	ORIGINAL PROJECTED COMPLETE DATE	PRESENT PROJECTED COMPLETE DATE
4 77 4566	TECH DATA/CONFIGURATION MANAGEMENT SYSTEM (TD/CMS) CONTRACT HAS BEEN EXTENDED TO 31 MAY 80, AN IN-PROCESS REVIEW REVIEW (IPR) WAS HELD AT THE CONTRACTOR'S PLANT. WORK IS PROGRESSING SATISFACTORILY.	500.0	473.4	26.6	JUN 79	JUN 80

APPENDICES

APPENDIX I: Command Identification

PRECEDING PAGE BLANK-NOT FILMED

APPENDIX I: ARMY ACTION COMMAND/ACTIVITY IDENTIFICATION

<u>Action Command</u>	<u>Acronym</u>	<u>Command Identifier</u>
Test & Evaluation Command	TECOM	0
Aviation R&D Command	AVRADCOM	1
Communications & Electronics Command	CERCOM	2
Tank-Automotive Materiel Readiness Command	TARCOM	4
Armament Materiel Readiness Command (Munitions)	ARRCOM (Ammo)	5
Armament R&D Command (Munitions)	ARRADCOM (Ammo)	8
Armament Materiel Readiness Command (Weapons)	ARRCOM (Wpns)	6
Armament R&D Command (Weapons)	ARRADCOM (Wpns)	9
Troop Support & Aviation Materiel Readiness Command	TSARCOM	7
Materiel Development & Readiness Command	DARCOM	D
Mobility Equipment R&D Command	MERADCOM	E
Communications R&D Command	CORADCOM	F
Electronics R&D Command	ERADCOM	H
Army Materials and Mechanics Research Center	AMMRC	M
Natick R&D Command	NARADCOM	Q
Missile Command	MICOM	R
Tank-Automotive R&D Command	TARADCOM	T

NOTE: Abbreviation - R&D Research and Development

APENDIX II: User's Guide

MANUFACTURING METHODS AND TECHNOLOGY PROGRAM
 SUMMARY REPORT
 2ND SEMI-ANNUAL SUBMISSION CY 79 MCS DACM1-301

PROJ NO.	TITLE + STATUS	AUTUM- RIZED (\$000)	CONTRACT VALUES (\$000)	EXPENDED ORIGINAL LARGR AND MATERIAL (\$000)	ORIGINAL PROJECTED COMPLETE DATE	PRESENT PROJECTED COMPLETE DATE
2 77 9835	INT CTRL CRCT FOR THIN FILM TRANSISTR DISPLAY AERJET HAD PROBLEMS MAKING TFT EL PANEL DISPLAYS, FUNDS WERE DEPLETED WITHOUT ACHIEVING GOALS. WORK TO ETCH THIN FILM CIRCUITS WITH 0.1 MIL TOLERANCE ON 4 INCH MASKS WILL CONTINUE ON FOLLOW-ON 279 9835. A SMALLER DISPLAY PACKAGE WILL RESULT.	448.8	398.8	50.0	MAR 79	AUG 81
F 79 9835	INTEGRATED THIN FILM TRANSISTOR DISPLAY AERJET FOLLOW-ON TO 2 77 9835. A MODIFICATION OF THE TFT EL ARRAY WILL ALLOW USE OF AVAILABLE ICS FOR THE D/SPRAY PERIPHERAL SCANNING CIRCUITRY. WORK WILL ESTABLISH COMPATIBILITY AMONG 23 THIN FILM LAYERS, INSULATING MATERIALS AND PROCESSES.	600.0	545.0		AUG 81	AUG 81
2 76 9898	RUGGEDIZED TACTICAL FIBER OPTIC CABLES ITT ELECTRO-OPTICS INSTALLED NEW HIGH SPEED OPTICAL CABLE STRANDER/SERVING LINE AND POLYURETHANE JACKET EXTRUSION LINE WITH FULL AUTOMATIC CONTROL. IT FABRICATES RUGGEDIZED FIBER OPTIC CABLE PROBLEMS. EACH FIBER IS OPT TESTER PRIOR TO STRANDING.	316.5	292.5	24.0	NOV 79	JUL 81
F 79 9938	THREE COLOR LIGHT EMITTING DIODE DISPLAY UNIT A PROFORMANT PACKAGE HAS BEEN SUBMITTED. BIDS ARE DUE ON 21 JAN 80. THIS PROJECT HAS NOT BEEN STARTED AND 13 MONTHS OF SLIPPAGE ARE ALREADY PROJECTED. PROBLEMS WITH THE PACING RWD ARE CITED AS THE REASCA FOR THE SLIPPAGE.	510.0		1.3	SEP 81	MAR 82

(1) (2) (3) (4) (5) (6) (7) (8) (9)

THIS FORM IS USED FOR SUMMARIZING
 THE MMT PROGRAM PROJECTS' STATUS.
 USER'S GUIDE BELOW EXPLAINS THE
 SIGNIFICANCE OF EACH COLUMN HEREIN.

USER'S GUIDE
to
SUMMARY PROJECT STATUS REPORT

COLUMN 1. PROJECT NUMBER

A project is identified by the first and last four digits which corresponds to the project title for the life of its execution. However, for accounting and reporting purposes, a project is recognized by the totality of its seven-digit numeral or alphanumeric number. Example:

3 75 6241

Project identifying number, which corresponds to the project title and is designated by action command.

Fiscal year of funding - the only two digits that may vary according to funding frequency (7T for FY transition).

Action command (see list in Appendix I).

COLUMN 2. Subtask identifier, if any.

COLUMN 3. PROJECT TITLE

The title descriptive of project effort.

COLUMN 4. An abstract of project status taken from the Project Status report. Whenever possible, technical accomplishments during the reporting period were summarized.

COLUMN 5. AUTHORIZED

The total amount of funds authorized in dollars, to complete the project.

COLUMN 6. CONTRACT VALUES

The portion of authorized funds actually expended or obligated for work performed by private industry.

COLUMN 7. EXPENDED LABOR AND MATERIAL

The portion of authorized funds actually expended in-house, namely within the Government.

COLUMN 8. ORIGINAL PROJECTED COMPLETION DATE

Calendar date clearly given in, or the nearest calendar month and year as could be read from the Milestone Chart of, the very first Project Status Report, RCS DRCMT-301.

COLUMN 9. PRESENT PROJECTED COMPLETION DATE

Calendar date clearly given in, or the nearest calendar month and year as could be read from the Milestone Chart of, the latest Project Status Report, RCS DRCMT-301.

APPENDIX III: Army MMT Program
Representatives

PRECEDING PAGE BLANK-NOT FILLED

ARMY MMT PROGRAM REPRESENTATIVES

HQ, DARCOM

US Army Materiel Development and Readiness Command

ATTN: DRCMT

5001 Eisenhower Avenue

Alexandria, VA 22333

C: 202 274-8284/8298

AV: 284-8284/8298

AVRADCOM

US Army Aviation R&D Command

ATTN: DRDAV-EXT, Mr. Robert Vollmer

12th & Spruce Streets

St. Louis, MO 63166

C: 314 263-1625

AV: 693-1625

CERCOM

US Army Communications & Electronics Materiel Readiness Command

ATTN: DRSEL-LE-R, Mr. Martin Ides

Fort Monmouth, NJ 07703

C: 201 532-4950

AV: 992-4950

CORADCOM

US Army Communications R&D Command

ATTN: DRDCO-PPA-TP, Mr. Al Feddeler/Sam Esposito/Burton Resnic

Building 2700

Fort Monmouth, NJ 07703

C: 201 535-2418/4262/4026

AV: 995-2418/4262/4026

ERADCOM

US Army Electronics R&D Command

ATTN: DELET-R, Mr. Joseph Key/Joan Teti

Fort Monmouth, NJ 07703

C: 201 544-4258

AV: 995-4258

MICOM

US Army Missile Command

ATTN: DRSMI-ET, Mr. Ray Farrison

Redstone Arsenal, AL 35809

C: 205 876-1835

AV: 746-1835

TARADCOM

US Army Tank-Automotive R&D Command

ATTN: DRJTA-KP, DRDTA-RCK, Dr. Jim Chevalier

Warren, MI 48090

C: 313 573-2065/1814/2467

AV: 273-2065/1814/2467

TARCOM

US Army Tank-Automotive Materiel Readiness Command

ATTN: DRSTA-EM, Ms. Vivian Buarkhalter

Warren, MI 48090

C: 313 573-2485

AV: 273-2485

ARRCOM

US Army Armament Materiel Readiness Command

ATTN: DR SAR-IRB, Mr. August Zahatko

Rock Island Arsenal

Rock Island, IL 61299

C: 309 794-4485/3730

AV: 793-4485/3730

ARRADCOM

US Army Armament R&D Command

ATTN: DRDAR-PML, Mr. Donald J. Fischer
Dover, NJ 07801

C: 201 328-6714/6715
AV: 880-6714/6715

TSARCOM

US Army Troop Support and Aviation Materiel Readiness Command

ATTN: DRSTS-PLP(2), Mr. Don G. Doll
4300 Goodfellow Blvd.
St. Louis, MO 63120

C: 314 263-3040
AV: 693-3040

MERADCOM

US Army Mobility Equipment R&D Command

ATTN: DRDME-UPE, Mr. S. O. Newman
Fort Belvoir, VA 22060

C: 703 664-5530
AV: 354-5530

NARADCOM

US Army Natick R&D Command

ATTN: DRDNA-EZM, Mr. Frank Civilikas
Natick, MA 01760

C: 617 653-1000, x2793/4
AV: 955-2349/2351

TECOM

US Army Test & Evaluation Command

ATTN: DRSTE-AD-M, Mr. Grover Shelton
Aberdeen Proving Ground, MD 21005

C: 301 278-3677
AV: 283-3677

AMMRC

US Army Materials & Mechanics Research Center

ATTN: DRXMR-PT, Mr. Raymond Farrow
Watertown, MA 02172

C: 617 923-3150
AV: 955-3150

HDL

Harry Diamond Laboratories

ATTN: DELHD-PP, Mr. Julius Hoke
2800 Powder Mill Road
Adelphi, MD 20783

C: 202 394-1551
AV: 290-1551

Rock Island Arsenal

ATTN: SARRI-ENM, Mr. Joseph DiBenedetto
Rock Island, IL 61299

C: 309 794-4627/4584
AV: 793-4627/4584

Watervliet Arsenal

ATTN: SARWV-PPI, Mr. L. A. Jette
Watervliet, NY 12189

C: 518 266-5318
AV: 794-5318

US Army Munitions Production Base Modernization Agency

ATTN: SARPM-PBM, Mr. Joseph Taglairino
Dover, NJ 07801

C: 201 328-6708
AV: 880-6708

AMRDL

US Army Air Mobility R&D Laboratories

ATTN: SAVDL-EU-TAS, Mr. L. Thomas Mazza
Fort Eustis, VA 23604

C: 804 878-5732
AV: 927-5732

IBEA

US Army Industrial Base Engineering Activity

ATTN: DRXIB-MT, Mr. James Carstens
Rock Island, IL 61299

C: 309 794-5113
AV: 793-5113

DCSRDA

ATTN: DAMA-CSM, Mr. Rod Vawter
Room 3C400, The Pentagon
Washington, DC 20310

C: 202 695-0506/07/08
AV: 225-0506/07/08

DCSRDA (PA 1497, Aircraft)

ATTN: DAMA-WSA, LTC Jay B. Bisbey
Room 3B454, The Pentagon
Washington, DC 20310

C: 202 695-1362
AV: 225-1362

DCSRDA (PA 2597, Missiles)

ATTN: DAMA-WSM-A, Mr. John Doyle
Room 3B485, The Pentagon
Washington, DC 20310

C: 202 695-8740
AV: 224-8740

DCSRDA (PA 3297, Weapons; PA 3197, Tracked Combat Vehicles)

ATTN: DAMA-WSW, MAJ Gordon Winder
Room 3D455, The Pentagon
Washington, DC 20310

C: 202 697-0106
AV: 227-0106

DCSRDA (PA 5297, Communications/Electronics)

ATTN: DAMA-CSC-BU, COL Higgins
Room 3D440, The Pentagon
Washington, DC 20310

C: 202 695-1881
AV: 225-1881

DCSRDA (Other Procurement Activities:

PA 5197, Tactical and Support Vehicles)

ATTN: DAMA-CSS-P, LTC L. R. Hawkins
Room 3D416, The Pentagon
Washington, DC 20310

C: 202 694-8720
AV: 224-8720

DCSRDA (Other Procurement Activities:

PA 5397, Other Support)

ATTN: DAMA-CSS-P, LTC P. K. Linscott
Room 3D418, The Pentagon
Washington, DC 20310

C: 202 694-8720
AV: 224-8720

DCSRDA (PA 4950, Ammunition)

ATTN: DAMA-CSM-DA, COL Jack King
Room 3C444, The Pentagon
Washington, DC 20310

C: 202 694-4330
AV: 224-4330

DCSRDA (PA 4950, Ammunition)

ATTN: DAMA-CSM-P, Mr. John Mytryshyn
Room 3C444, The Pentagon
Washington, DC 20310

C: 202 694-4330
AV: 224-4330

DISTRIBUTION

PRECEDING PAGE BLANK-NOT FILMED

DRXIB-MT
DISTRIBUTION:

Defense Documentation Center:

Document Processing Division, Attn: DDC-DDA-2, Mr. Richard Matthews (12 cys)

Department of Defense:

DIRSO, Attn: Mr. Charles Downer (3 cys)
OUSD (R&D), The Pentagon, Attn: Dr. Lloyd L. Lehn (2 cys)

Department of the Army:

HQDA, OASARDA, The Pentagon, Attn: Mr. Eugene S. Davidson
HQDA, ODCSRDA, The Pentagon, Attn: DAMA-PPM-P, Mr. Rod Vawter

HQ DARCOM:

Cdr, DARCOM, Attn: DRCCG
Cdr, DARCOM, Attn: DRCDMD
Cdr, DARCOM, Attn: DRCDMR
Cdr, DARCOM, Attn: DRCPD
Cdr, DARCOM, Attn: DRCPD-I (3 cys)
Cdr, DARCOM, Attn: DRCDL
Cdr, DARCOM, Attn: DRCDT (20 cys)

Project/Product Managers:

PM, Advanced Attack Helicopter, Attn: DRCPM-AAH (AVRADCOM)
PM, Aircraft Survivability Equipment (ASE), Attn: DRCPM-ASE (AVRADCOM)
PM, Amphibians and Watercraft (AWC), Attn: DRCPM-AWC (TSARCOM)
PM, Armored Combat Vehicle Technology (ACVT), Attn: DRCPM-CVT (TARADCOM)
PM, Army Tactical Communications Systems (ATACS), Attn: DRCPM-ATC (CORADCOM)
PM, Army Tactical Data Systems (ARTADS), Attn: DRCPM-TDS (CORADCOM)
PM, Automatic Test Support Systems, Attn: DRCPM-ATSS (CORADCOM)
PM, Blackhawk, Attn: DRCPM-BH (AVRADCOM)
PM, Cannon Artillery Weapons Systems, Attn: DRCPM-CAWS (ARRADCOM)
PM, CH-47 Mod. Program, Attn: DRCPM-CH47M (AVRADCOM)
PM, CHAPARRAL/FAAR, Attn: DRCPM-CF (MICOM)
PM, Chemical Demilitarization & Installation Restoration, Attn: DRCPM-DR (APG)
PM, COBRA, Attn: DRCPM-CO (TSARCOM)
PM, Division Air Defense (DIVAD) Gun, Attn: DRCPM-ADG (ARRADCOM)
PM, Family of Military Engr. Construc. Equip. (FAMECE)/Univsl. Engr. Tractor (UET), Attn: DRCPM-FM (MERADCOM)
PM, Fighting Vehicle Armament, Attn: DRCPM-FVA (TARADCOM)
PM, Fighting Vehicle Systems, Attn: DRCPM-FVS (TARADCOM)
PM, FIREFINDER, Attn: DRCPM-FF (ERADCOM)
PM, General Support Rocket System, Attn: DRCPM-RS (MICOM)
PM, Ground Laser Designators, Attn: DRCPM-LD (MICOM)
PM, HAWK, Attn: DRCPM-HA (MICOM)
PM, Heavy Equipment Transporter (HET), Attn: DRCPM-HT (TARCOM)
PM, Heliborne Laser Fire and Forget (HELLFIRE) Missile System, Attn: DRCPM-HE (MICOM)

DRXIB-MT
DISTRIBUTION (Cont'd):

Project/Product Managers (Cont'd):

PM, High Energy Laser System, Attn: DRCPM-HEL (MICOM)
PM, Improved TOW Vehicle, Attn: DRCPM-ITV (TARADCOM)
PM, LANCE, Attn: DRCPM-LC (MICOM)
PM, M60 Tank Development, Attn: DRCPM-M60TD (TARCOM)
PM, M60 Tank Production, Attn: DRCPM-M60TP (TARCOM)
PM, M110E2 Weapon System, Attn: DRSAR-HA (ARRCOM)
PM, M113/M113A1 Family of Vehicle Readiness, Attn: DRCPM-M113 (TARCOM)
PM, Mobile Electric Power, Attn: DRCPM-MEP (Springfield, VA)
PM, Multi-Service Communications Systems, Attn: DRCPM-MSCS (CORADCOM)
PM, Navigation Control Systems (NAVCON), Attn: DRCPM-NC (ERADCOM)
PM, Nuclear Munitions, Attn: DRCPM-NUC (ARRADCOM)
PM, PATRIOT, Attn: DRCPM-MD (MICOM)
PM, PERSHING, Attn: DRCPM-PE (MICOM)
PM, Remotely Monitored Battlefield Sensor Systems (REMBASS), Attn: DRCPM-RBS (ERADCOM)
PM, 2.75 Rocket System, Attn: DRCPM-RK (MICOM)
PM, SATCOM, Attn: DRCPM-SC (ERADCOM)
PM, Selected Ammunition, Attn: DRCPM-SA (ARRADCOM)
PM, Signal Intelligence/Electronic Warfare (SIGINT/EW), Attn: DRCPM-SIEW (CERCOM)
PM, Single Channel Ground and Airborne Radio Subsystem (SINGGARS), Attn: DRCPM-GARS (CORADCOM)
PM, Smoke/Obscurants (SMOKE), Attn: DRCPM-SMK (APG)
PM, Special Electronic Mission Aircraft (SEMA), Attn: DRCPM-AE (TSARCOM)
PM, Stand-off Target Acquisition System, Attn: DRCPM-STA (ERADCOM)
PM, STINGER, Attn: DRCPM-MP (MICOM)
PM, TOW-DRAGON, Attn: DRCPM-DT (MICOM)
PM, Training Devices, Attn: DRCPM-TND (Orlando, FL)
PM, US ROLAND, Attn: DRCPM-ROL (MICOM)
PM, VIPER, Attn: DRCPM-VI (MICOM)
PM, XM-1 Tank System, Attn: DRCPM-GCM (TARADCOM)

Project Officers:

PO, M60A1 Tank Camouflage Pilot Program, Attn: DRXFB-RT
PO, SLUFAE/SLUMINE, Surface Launch Unit Fuel Air Explosive (SLUFAE) Mine Neutralization System/Surface Launched Unit Mine (SLUMINE) Dispensing System, Attn: DRDME-NS (Ft. Belvoir)
PO, Stand-Off Target Acquisition/Attack System (SOTAS), Attn: DRSEL-CT
PO, Test, Measurement, and Diagnostic Equipment, Attn: DRCRE-T (DARCOM)
PO, Tactical Shelters, Attn: DRXNM-UBS

Major Subcommands:

Cdr, ARRCOM, Attn: DRSAR-CG
Cdr, ARRADCOM, Attn: DRDAR
Cdr, AVRADCOM, Attn: DRDAV
Cdr, CERCOM, Attn: DRSEL

DRXIB-MT
DISTRIBUTION (Cont'd):

Major Subcommands (Cont'd):

Cdr, CORADCOM, Attn: DRDCO
Cdr, DESCOM, Attn: DRSDS
Cdr, ERADCOM, Attn: DRDEL
Cdr, MICOM, Attn: DRSMI
Cdr, TARADCOM, Attn: DRDTA
Cdr, TARCOM, Attn: DRSTA
Cdr, TECOM, Attn: DRSTE
Cdr, TSARCOM, Attn: DRSTS
Cdr, MERADCOM, Attn: DRDME
Cdr, NARADCOM, Attn: DRDNA
Dir, USAILCOM, Attn: DRCIL

Arsenals:

Cdr, Pine Bluff Arsenal (PBA), Attn: SARPB
Cdr, Rock Island Arsenal (RIA), Attn: SARRI-CO
Cdr, Rocky Mountain Arsenal (RMA), Attn: SARRM-IS (2 cys)
Cdr, Watervliet Arsenal (WVA), Attn: SARWV

Army Ammunition Plants:

Cdr, Crane AAP, Attn: SARCN
Cdr, Hawthorne AAP, Attn: SARHW
Cdr, Holston AAP, Attn: SARHO
Cdr, Indiana AAP, Attn: SARIN
Cdr, Iowa AAP, Attn: SARIO
Cdr, Kansas AAP, Attn: SARKA
Cdr, Lake City AAP, Attn: SARLC
Cdr, Lone Star AAP, Attn: SARLS
Cdr, Longhorn AAP, Attn: SARLO
Cdr, Louisiana AAP, Attn: SARLA
Cdr, McAlester AAP, Attn: SARMC-FD
Cdr, Milan AAP, Attn: SARMI
Cdr, Mississippi AAP, Attn: SARMS
Cdr, Radford AAP, Attn: SARRA
Cdr, Riverbank AAP, Attn: SARRB
Cdr, Scranton AAP, Attn: SARSC

Depots:

Cdr, Anniston Army Depot, Attn: SDSAN-MD
Cdr, Corpus Christi Army Depot, Attn: SDSCC-MPI
Cdr, Letterkenny Army Depot, Attn: SDSLE-MM
Cdr, New Cumberland Army Depot, Attn: SDSNC-ME
Cdr, Red River Army Depot, Attn: SDSRR-MO
Cdr, Sacramento Army Depot, Attn: SDSA-MPE
Cdr, Seneca Army Depot, Attn: SDSSE-OP
Cdr, Sharpe Army Depot, Attn: SDSSH-R

DRXIB-MT
DISTRIBUTION (Cont'd):

Depots (Cont'd):

Cdr, Sierra Army Depot, Attn: SDSSI-EM
Cdr, Tobyhanna Army Depot, Attn: SDSTO-M
Cdr, Tooele Army Depot, Attn: SDSTE-MAN

Depot Activities:

Cdr, Lexington-Blue Grass Army Depot Activity, Attn: SDSLE
Cdr, Navajo Army Depot Activity, Attn: SDSTE-N
Cdr, Pueblo Army Depot Activity, Attn: SDSTE-PUM
Cdr, Savanna Army Depot Activity, Attn: SDSLE-VM
Cdr, Umatilla Army Depot Activity, Attn: SDSTE-UM
Cdr, Fort Wingate Army Depot Activity, Attn: DRXFW

DARCOM Laboratories and Schools:

Cdr, Army Ballistic Research Labs (BRL), Attn: DRDAR-BL
Cdr, Army Equipment Authorizations Review Acty. (EARA), Attn: DRXEA-C
Cdr, Army Harry Diamond Labs (HDL), Attn: DELHD
Dir, Army Human Engineering Labs (HEL), Attn: DRXHE
Cdr, Army Logistics Management Ctr. (ALMC), Attn: DRXMC-AL, DRXMC-ITC-E,
Mr. Reinecke
Cdr, Army Maintenance Management Ctr., Attn: DRXMD
Dir, Army Management Engineering Training Acty. (AMETA), Attn: DRXOM-SE,
Dr. Shallman
Cdr, Foreign Science and Technology Ctr. (FSTC), Attn: Mr. James Wamsley
Cdr, Joint Military Packing Training Ctr., Attn: DRXPP-A
Cdr, Night Vision Labs (NVL), Attn: DRSEL-NV-PA/IO
Cdr, Watervliet Arsenal, ATTN: DRDAR-LCB-S, Mr. M. L. Slawsky

Army Organizations:

Dir, AMMRC, Attn: DRXMR, DRXMR-M (3 cys)
Dir, AMMRC, Attn: DRXMR-EO, Dr. Morton Kliman
Cdr, APG, Attn: STEAP-MT-M, Mr. J. L. Sanders
Cdr, Army Research Office (ARO), Attn: DRXRO-AO
Cdr, Army Weapons Support Center, Crane, IN
Cdr, ARRCOM, Attn: DRSAR-IRW, Mr. Arne Madsen
Cdr, ARRCOM, Attn: DRSAR-LEP, R. F. Tumasonis (6 cys)
Cdr, ARRADCOM, Attn: DRDAR-TDA, Mr. Joe Blick
Cdr, CORADCOM, Attn: DRDCO-PE-EC-I, Mr. Stan Sokolove
Cdr, DESCOM, Attn: DRSDS-PMI, Mr. Allen Updegrave, DRSDS-EI (NC/CAM); SAD
Cdr, ERADCOM, Attn: DRDEL-ED, Mr. Robert Ruth/Mr. Harold Garson
Dir, Installations & Services Activity (I&SA), Attn: DRCIS-RI

MT Representatives:

Cdr, ARRADCOM, Attn: DRDAR-PML, Mr. Donald J. Fischer (7 cys)
Cdr, ARRCOM, Attn: DRSAR-IRB, Mr. August Zahatko (5 cys)
Cdr, AVRADCOM, Attn: DRDAV-EXT, Mr. Robert Vollmer
Cdr, CERCOM, Attn: DRSEL-LE-R, Mr. Martin Ides
Cdr, CORADCOM, Attn: DRDCO-PPA-TP, Mr. Al Feddeler/Sam Esposito/Burton Resnic

DRXIB-MT

DISTRIBUTION (Cont'd):

MT Representatives (Cont'd):

Cdr, ERADCOM, Attn: DELET-R, Mr. Joseph Key/Bernard Reich
Cdr, MERADCOM, Attn: DRDME-UPE, Mr. S. O. Newman
Cdr, MICOM, Attn: DRSMI-ET, Mr. Ray Farrison
Cdr, NARADCOM, Attn: DRDNA-EZM, Mr. Frank Civilikas
Cdr, TARADCOM, Attn: DRDTA-KP, DRDTA-RCK, Dr. Jim Chevalier
Cdr, TARCOM, Attn: DRSTA-EM, Ms. Vivian Buarkhalter
Cdr, TECOM, Attn: DRSTE-AD-M, Mr. Glover Shelton
Cdr, TSARCOM, Attn: DRSTS-PLEP (2), Mr. Don G. Doll
Dir, AMMRC, Attn: DRXMR-PT, Mr. Raymond Farrow
Cdr, HDL, Attn: DELHD-PP, Mr. Julius Hoke
Cdr, AMRDL, Attn: SAVDL-EU-TAS, Mr. L. Thomas Mazza
Cdr, RIA, Attn: SARRI-ENM, Mr. Joseph DiBenedetto
Cdr, WVA, Attn: SARWV-PPI, Mr. L. A. Jette
PM, MPBM&E, Attn: DRCPM-PBM-DP, Mr. Joseph Taglairino
DCSRDA, Attn: DAMA-WSA, LTC Jay B. Bisbey
DCSRDA, Attn: DAMA-WSM-A, Mr. John Doyle
DCSRDA, Attn: DAMA-WSW, MAJ Gordon Winder
DCSRDA, Attn: DAMA-CSC-BU, COL Higgins
DCSRDA, Attn: DAMA-CSS-P, LTC L. R. Hawkins, LTC P. K. Linscott
DCSRDA, Attn: DAMA-CSM-P, Mr. John Mytryshyn
DCSRDA, Attn: DAMA-CSM-DA, COL Jack King

Navy Activities:

Cdr, NAVMAT, Attn: CPT F. B. HOLLICK, Code 064
Cdr, NAVMIRO, Attn: Officer-In-Charge
Cdr, NAVSEA, Attn: T. E. Draschil, Code C-0354
Cdr, NAVAIR, Attn: D. S. Henderson, Code ESA-824
Cdr, NAVLEX, Attn: C. A. Rigdon, Code ELEX-504512
Cdr, Naval Surface Weapons Ctr/White Oak Lab, Attn: Code E345, Mr. Chas. McFann
Cdr, Naval Surface Weapons Ctr/Dahlgren Lab, Attn: Code CM-51
Cdr, Naval Weapons Ctr, Attn: D. M. Bullat, Code 36804

Air Force Activities:

Cdr, HQ, USAF/RDXI, The Pentagon, Attn: MAJ D. Mackintosh
Cdr, AFSC/DLF, Andrew AFB
Cdr, AFSC/DLFF, Andrew AFB
Cdr, AFSC/PPD, Andrew AFB
Cdr, AFSC/PPDE, Andrew AFB
Cdr, AFML/LT, Wright-Patterson AFB
Cdr, AFML/LTE, /LTM, /LTN, Wright-Patterson AFB
Cdr, AFML/MX, Wright-Patterson AFB
Cdr, San Antonio Air Logistics Ctr, Kelly AFB, Attn: E. Boisvert, MMEWA

LMED
8