

AD-A080 819

FOREIGN TECHNOLOGY DIV WRIGHT-PATTERSON AFB OH
HIGH-VOLTAGE VARIABLE CAPACITANCE CAPACITOR, (U)
MAR 79 I I KALYATSKIY, V I KURETS

F/G 9/1

UNCLASSIFIED

FTD-ID(RS)T-0261-79

NL

1 of 1
AC 1080819



END
DATE
FILMED
3-80
ADIC

PHOTOGRAPH THIS SHEET

ADA 080819

DTIC ACCESSION NUMBER

LEVEL

INVENTORY

FTD-ID(RS)T-0261-79
DOCUMENT IDENTIFICATION

DISTRIBUTION STATEMENT A
Approved for public release;
Distribution Unlimited

DISTRIBUTION STATEMENT

ACCESSION FOR	
NTIS	GRA&I <input checked="" type="checkbox"/>
DTIC	TAB <input type="checkbox"/>
UNANNOUNCED	<input type="checkbox"/>
JUSTIFICATION	
BY	
DISTRIBUTION /	
AVAILABILITY CODES	
DIST	AVAIL AND/OR SPECIAL
A	

DDC
RECEIVED
FEB 19 1980
D

DATE ACCESSIONED

DISTRIBUTION STAMP

DATE RECEIVED IN DTIC

PHOTOGRAPH THIS SHEET AND RETURN TO DTIC-DDA-2

ADA 080819

FTD-ID(RS)T-0261-79

FOREIGN TECHNOLOGY DIVISION



HIGH-VOLTAGE VARIABLE CAPACITANCE CAPACITOR

by

I. I. Kalyatskiy, V. I. Kurets, et al.

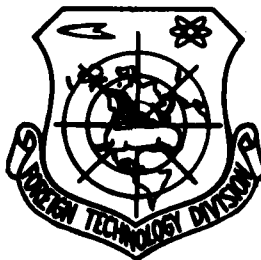

Approved for public release;
distribution unlimited.

79 08 20 179

EDITED TRANSLATION

FTD-ID(RS)T-0261-79

14 March 1979

MICROFICHE NR: *AD-79-C-000395*

HIGH-VOLTAGE VARIABLE CAPACITANCE CAPACITOR

By: I. I. Kalyatskiy, V. I. Kurets, et al.

English pages: 2

Source: USSR Patent Nr. 337837, 5 May 1972,
pp. 1-2

Country of origin: USSR

Translated by: SCITRAN

F33657-78-D-0619

Requester: FTD/TQTD

Approved for public release; distribution
unlimited.

THIS TRANSLATION IS A RENDITION OF THE ORIGINAL FOREIGN TEXT WITHOUT ANY ANALYTICAL OR EDITORIAL COMMENT. STATEMENTS OR THEORIES ADVOCATED OR IMPLIED ARE THOSE OF THE SOURCE AND DO NOT NECESSARILY REFLECT THE POSITION OR OPINION OF THE FOREIGN TECHNOLOGY DIVISION.

PREPARED BY:

TRANSLATION DIVISION
FOREIGN TECHNOLOGY DIVISION
WP-afb, OHIO.

U. S. BOARD ON GEOGRAPHIC NAMES transliteration SYSTEM

Block	Italic	Transliteration	Block	Italic	Transliteration
А а	А а	A, a	Р р	Р р	R, r
В в	В в	B, b	С с	С с	S, s
В в	В в	V, v	Т т	Т т	T, t
Г г	Г г	G, g	У у	У у	U, u
Д д	Д д	D, d	Ф ф	Ф ф	F, f
Е е	Е е	Ye, ye; E, e*	Х х	Х х	Kh, kh
Ж ж	Ж ж	Zh, zh	Ц ц	Ц ц	Ts, ts
З з	З з	Z, z	Ч ч	Ч ч	Ch, ch
И и	И и	I, i	Ш ш	Ш ш	Sh, sh
Й й	Й й	Y, y	Щ щ	Щ щ	Shch, shch
К к	К к	K, k	Ъ ъ	Ъ ъ	"
Л л	Л л	L, l	Ы ы	Ы ы	Y, y
М м	М м	M, m	Ь ь	Ь ь	'
Н н	Н н	N, n	Э э	Э э	E, e
О о	О о	O, o	Ю ю	Ю ю	Yu, yu
П п	П п	P, p	Я я	Я я	Ya, ya

*ye initially, after vowels, and after ъ, ь; e elsewhere.
When written as ё in Russian, transliterate as yë or ë.

RUSSIAN AND ENGLISH TRIGONOMETRIC FUNCTIONS

Russian	English	Russian	English	Russian	English
sin	sin	sh	sinh	arc sh	sinh ⁻¹
cos	cos	ch	cosh	arc ch	cosh ⁻¹
tg	tan	th	tanh	arc th	tanh ⁻¹
ctg	cot	cth	coth	arc cth	coth ⁻¹
sec	sec	sch	sech	arc sch	sech ⁻¹
cosec	csc	csch	csch	arc csch	csch ⁻¹

Russian	English
rot	curl
lg	log

Committee on Inventions
and Discoveries
in the USSR Council of
Ministers

DESCRIPTION OF INVENTION
For the Inventor's Patent
Subject to Patent No. _
Applied for 13.X.1967 (No. 1189985/26-9)
accompanied by application form No. _
Priority _
Published 05.V.1972. Bulletin No. 15
Date of publication of description
1.VI.1972

Inventors: I. I. Kalyatskiy, V. I. Kurets, V. N. Ponomarev, V. N. Safronov and V. A. Tsukerman
Applicant: The Tomsk S. M. Kirov Order of the Red Banner of Labor Polytechnical Institute

HIGH-VOLTAGE VARIABLE CAPACITANCE CAPACITOR

1

The invention belongs to the field of radio engineering, in particular to the shaping of high-voltage pulses of voltage and current.

High-voltage variable capacitance capacitors which consist of two cylindrical plates with a conducting rod and control capacitances are well known.

The purpose of the invention is smooth regulation of the capacitance of the capacitor when the intrinsic inductance is constant.

The proposed capacitor is shown in the drawing.

The high-voltage capacitor consists of the cylindrical plate 1 with ground and the plate 2 connected to the conducting rod 3 which has polyethylene insulation. A high-voltage pulse is fed to the rod.

1

The air-tightness of the capacitor is maintained by the insulated bottom 4 and the insulating cover 5. Coaxiality of the cylinders is ensured due to threaded fastening of the conducting rod 3 in the cover 5. Transformer oil serves as a dielectric in the upper part of the capacitor, and glycerin in the lower part.

The volume occupied by the transformer oil and the glycerin is regulated smoothly by means of the reservoirs 6 and 7 through the tubing 8 and 9. The required magnitude of the capacitor capacitance is calculated from the conditions for the equality of the volumes occupied by the glycerin and the transformer oil.

Subject of the Invention

The high-voltage variable capacitance capacitor consisting of two cylindrical casings with a conducting rod and control capacitances is distinguished by the fact that in order to regulate smoothly the magnitude of the capacitance of the capacitor when the intrinsic inductance is constant, two liquids are used as dielectrics. These liquids do not mix, they have different dielectric and physical properties, and their volumes are regulated in the capacitor.

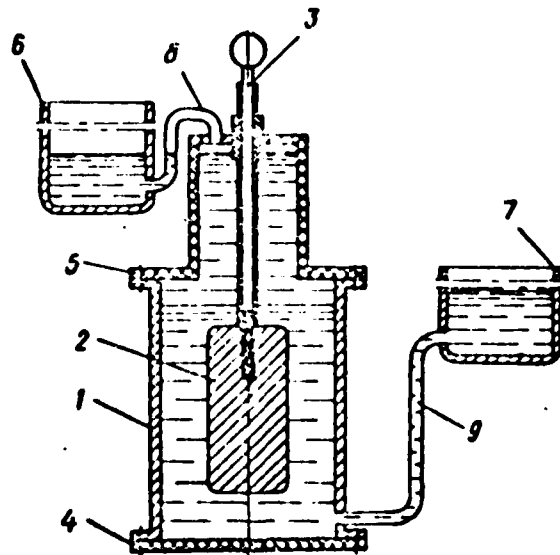

DISTRIBUTION LIST

DISTRIBUTION DIRECT TO RECIPIENT

<u>ORGANIZATION</u>	<u>MICROFICHE</u>	<u>ORGANIZATION</u>	<u>MICROFICHE</u>
A205 DMATC	1	E053 AF/INAKA	1
A210 DMAAC	2	E017 AF/RDXTR-W	1
B344 DIA/RDS-3C	9	E403 AFSC/INA	1
C043 USAMIIA	1	E404 AEDC	1
C509 BALLISTIC RES LABS	1	E408 AFWL	1
C510 AIR MOBILITY R&D LAB/FIO	1	E410 ADTC	1
C513 PICATINNY ARSENAL	1	FTD	
C535 AVIATION SYS COMD	1	CCN	1
C591 PSTC	5	ASD/FTD/NIIS	3
C619 MIA REDSTONE	1	NIA/PHS	1
D008 NISC	1	NIIS	2
H300 USAICE (USAREUR)	1		
P005 DOF	1		
P050 CIA/CRB/ADD/SD	1		
NAVORDSTA (50L)	1		
NASA/KSI	1		
AFIT/LD	1		
ILL/Code I-389	1		
NSA/1213/TDL	2		