

12  
B.S.

AD

TECHNICAL REPORT  
NATICK/TR-80/008

ADA 080263

LEVEL

**ROTATABLE CLAMP  
FOR BALLISTIC TESTING OF FABRIC**

by

Frank Figucia

DDC FILE COPY

DDC  
RECEIVED  
FEB 6 1980  
A

Approved for public release;  
distribution unlimited.

September 1979

UNITED STATES ARMY  
NATICK RESEARCH and DEVELOPMENT COMMAND  
NATICK, MASSACHUSETTS 01760



Clothing, Equipment and Materials  
Engineering Laboratory  
CEMEL-204

80 2 5 196

Approved for public release; distribution unlimited.

Citation of trade names in this report does not constitute an official indorsement or approval of the use of such items.

Destroy this report when no longer needed. Do not return it to the originator.

REPORT DOCUMENTATION PAGE		READ INSTRUCTIONS BEFORE COMPLETING FORM
1. REPORT NUMBER NATICK/TR-80/008	2. GOVT ACCESSION NO.	3. REPORT'S CATALOG NUMBER 9
4. TITLE (and Subtitle) ROTATABLE CLAMP FOR BALLISTIC TESTING OF FABRIC	5. DATE OF REPORT & PERIOD COVERED Technical Report Oct 78 - Sep 79	
7. AUTHOR(s) FRANK/FIGUCIA	6. PERFORMING ORG. REPORT NUMBER 14 CEMEL-204 7. CONTRACT OR GRANT NUMBER(s) 16	
9. PERFORMING ORGANIZATION NAME AND ADDRESS US Army Natick Research & Development Command Kansas Street Natick, MA 01760	10. PROGRAM ELEMENT, PROJECT, TASK AREA & WORK UNIT NUMBERS 62723A 1L162723AH98 CC 009	
11. CONTROLLING OFFICE NAME AND ADDRESS Fiber & Fabric Technology Branch Textile Research & Engineering Division, CEMEL US Army Natick R&D Command, Natick, MA 01760	12. REPORT DATE 14 September 1979 17 CC	
14. MONITORING AGENCY NAME & ADDRESS (if different from Controlling Office) 18 NATICK	13. NUMBER OF PAGES 15 12 17	
15. SECURITY CLASS. (of this report) UNCLASSIFIED		15a. DECLASSIFICATION/DOWNGRADING SCHEDULE
16. DISTRIBUTION STATEMENT (of this Report) Approved for public release; distribution unlimited. 19 TR-80/008		
17. DISTRIBUTION STATEMENT (of the abstract entered in Block 20, if different from Report)		
18. SUPPLEMENTARY NOTES		
19. KEY WORDS (Continue on reverse side if necessary and identify by block number) BALLISTICS ROTATABLE FABRIC CLAMP BALLISTIC TESTING FIRING TESTS (ORDNANCE) FABRICS STRESS STRAIN RELATIONS YARNS CLAMPS		
20. ABSTRACT (Continue on reverse side if necessary and identify by block number) Description of the structural and functional features of a newly designed test fixture is presented. Test device is used as a research tool for holding small fabric specimens in position for low velocity ballistic impact tests. Rotational capability allows for five replicate firings against single fabric swatch.		

408 902

JOB

## Table of Contents

	Page
I. Introduction	3
II. Transient Deformation Range	3
III. Rotatable Fabric Clamp	4
A. Description	4
B. Advantages	7
IV. Conclusions	7
Appendix	9

SEARCHED  
SERIALIZED  
INDEXED  
FILED

APR 19 1964

FBI - MEMPHIS

A

## List of Figures

	<b>Page</b>
Figure 1. Transient Deformation Range	3
Figure 2. Rotatable Fabric Clamp Components	4
Figure 3. Top and Bottom Plates	5
Figure 4. One Layer of Fabric Ready for Clamping	5
Figure 5. Several Layers of Fabric Ready for Clamping	5
Figure 6. Fabric Holder Plates Clamped Together	5
Figure 7. Fabric Stand Base and Holder Mount	6
Figure 8. Holder Mount Lowered and Rotated	6
Figure 9. Unit Loaded for Firing at Center Hole	6
Figure 10. Unit Lowered and Rotated	6
Figure 11. Rear View Raised Position	7
Figure 12. Rear View Lowered and Rotated	7
Figure A-1. Fabric Stand Assembly	10
Figure A-2. Fabric Stand Base	11
Figure A-3. Fabric Stand Holder Mount	12
Figure A-4. Fabric Holder Assembly	13
Figure A-5. Fabric Holder (Top Plate)	14
Figure A-6. Fabric Holder (Bottom Plate)	15

## ROTATABLE CLAMP FOR BALLISTIC TESTING OF FABRIC

### I. Introduction

During Fiscal Year 1976, new test methodology was developed at this Command to facilitate in-house ballistic research efforts. A test apparatus was designed through which stress-strain behavior of single yarns could be evaluated during low-velocity transverse impact. The system consists of an air actuated missile launching barrel and appropriate instrumentation to characterize physical yarn responses.

More recently, interest in single yarn behavior has been expanded to include translational effects brought about by the incorporation of single yarn strands into higher ordered woven forms. In keeping with this change, the test facility was modified by the addition of a newly designed holding clamp for small woven fabric samples.

The objective of this report is to describe in detail the constructional and functional features of the sample holder.

The all aluminum test fixture was named the *Rotatable Fabric Clamp*. Two basic considerations were stressed in its design, namely, compatibility with the already established test facility, and accuracy of results.

Results obtained under research task CC, work unit 009, of project 1L162723AH98 showed that these requirements were met successfully. Details of that work will be published in a separate report.

### II. Transient Deformation Range

The ballistic range in which the Rotatable Fabric Clamp is used is a scaled-down version of a standard ballistic firing range, many of which are in operation in Government and private installations throughout the world. Figure 1 shows the NARADCOM setup in very basic schematic form.

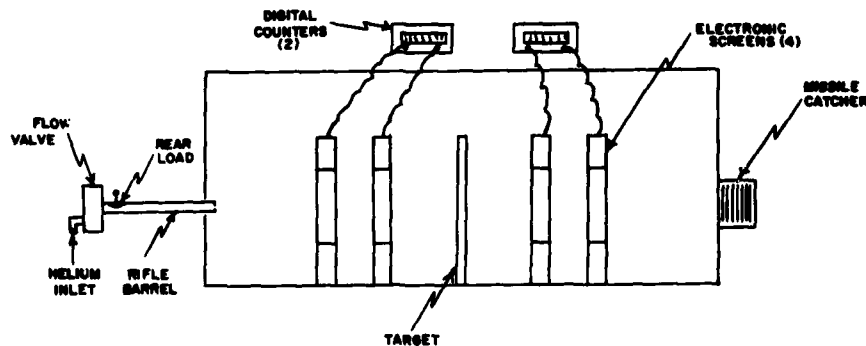

Figure 1. Transient Deformation Range

The projectile used is a 17-grain fragment simulating missile which is propelled by compressed helium gas. The velocity capability with helium is less than attainable with gun powder, such as is used in conventional ranges. However, the maximum achievable velocity of approximately 427 m/s (1400 ft/s) is adequate for the intended purpose and certain dangers associated with the use of gun powder are eliminated. The missile is breech-loaded and propelled down range by the expansion of the helium gas through an appropriate flow valve.

The total length of the range from barrel tip to missile catcher is only 1.3 m (53 in). This places all operational procedures practically within arm's reach and greatly increases efficiency. The flight of the missile is monitored by electronic screens whose output signals activate digital counting devices. Through the use of this system, striking and residual velocities and corresponding energies may be calculated for the missile before and after impact with the target.

### III. Rotatable Fabric Clamp

#### A. Description

Figure 2 shows the Rotatable Fabric Clamp components, consisting of the fabric holder, A, and the fabric stand assembly. The fabric stand assembly is made up of fabric stand holder mount, B, and fabric stand base, C (See design drawings in Appendix).

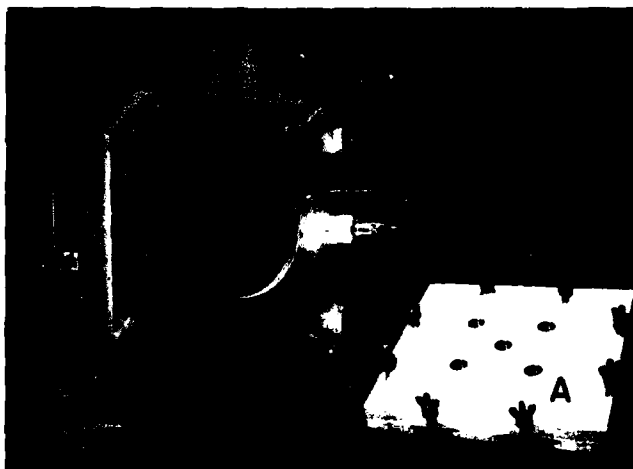
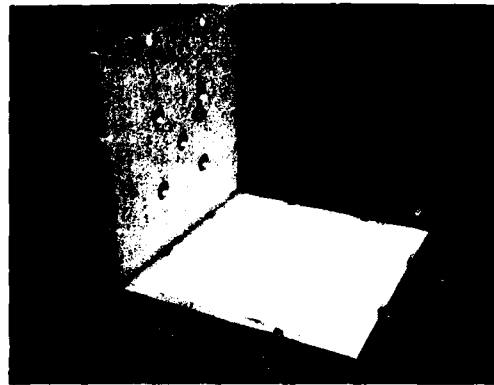

Figure 2. Rotatable Fabric Clamp Components

The fabric holder, A, is shown in closer detail in Figures 3-6. Figure 3 shows top and bottom plates separated. Figures 4 and 5 show one layer and several layers of fabric respectively placed on the bottom plate ready to be clamped. Figure 6 shows the fabric holder with both plates clamped together by the wing nuts.



**Figure 3. Top and Bottom Plates**



**Figure 4. One Layer of Fabric Ready for Clamping**

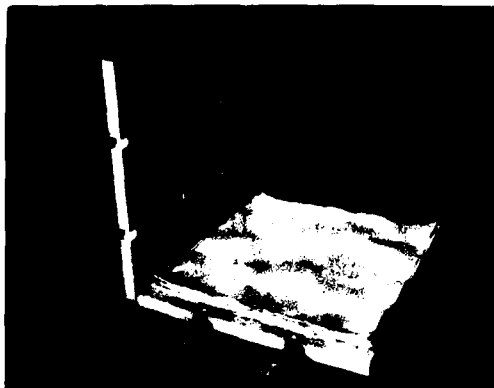

**Figure 5. Several Layers of Fabric Ready for Clamping**



**Figure 6. Fabric Holder Plates Clamped Together**



The fabric holder, when loaded with material, is mounted in the four corner support blocks of the fabric stand holder mount, B, shown in Figure 7. The fabric holder is secured to the holder mount by a Detroit Stamping Co. Model 202 Pressure Clamp, D. The entire fabric stand assembly is placed in the path of the missile and bolted securely. The fabric stand holder mount is held in the position shown in Figure 7 by pin, E. When this pin is removed, the holder mount is lowered 76 mm (3 in) vertically with relation to the fabric stand base, C. While in the lowered position, the holder mount may be rotated to any desired position. Figure 8 shows the holder mount after the pin has been removed and the holder mount lowered 76 mm (3 in) and rotated 45°. Notice that support block, F, has contacted the spring loaded stop, G.

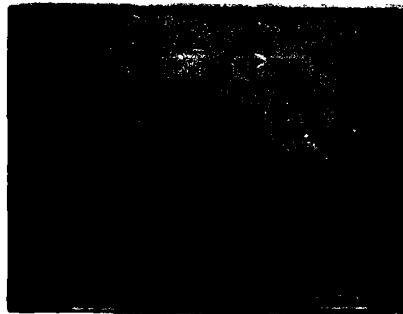

Figure 7. Fabric Stand Base and Holder Mount



Figure 8. Holder Mount Lowered and Rotated

Figures 9 and 10 show the entire unit loaded for firing. In Figure 9, with the holder mount in the raised position (pin in place), the center hole is in the path of the missile. In Figure 10, the pin has been removed and the fabric holder mount, with fabric holder clamped to it, has been lowered and rotated 45°, thereby presenting hole, H, to the path of the missile. Subsequent clockwise 90° rotations will allow for shots through holes J, K, and L.



Figure 9. Unit Loaded for Firing at Center Hole



Figure 10. Unit Lowered and Rotated

Figures 11 and 12 show the Rotatable Fabric Clamp from the rear, in both the raised position (Figure 11), for firing through the center hole, and the lowered position (Figure 12). The Figures show the annular ring portion, M, of the holder mount, which provides the mechanism for vertical and rotational motion.



Figure 11. Rear View Raised Position

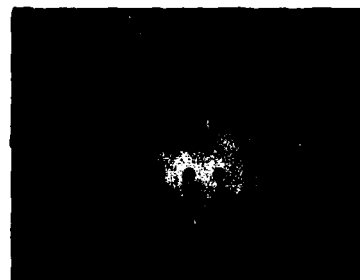

Figure 12. Rear View Lowered and Rotated

#### B. Advantages

The data obtained in the aforementioned research task were applied to predict  $V_{50}$  potential of materials from considerably smaller samplings of fabric than are necessary in actual  $V_{50}$  firings. A more thorough narration of the method will be presented in a later report, where it will be shown that use of the Rotatable Fabric Clamp provides distinct advantages over conventional  $V_{50}$  testing methods. Among these are cost savings due to reduced use of material and time, improvement in reproducibility of results, and elimination of adverse effects of previously strained yarns on subsequent firings.

#### IV. Conclusions

A viable system has been developed for testing ballistic materials. The system features the Rotatable Fabric Clamp. Initial studies have proven highly successful and additional studies will be conducted to test further the accuracy and validity of the system.

**APPENDIX**

**DRAWINGS**

**Note: Conventional units used conform with US  
Customary machine tool processing.**

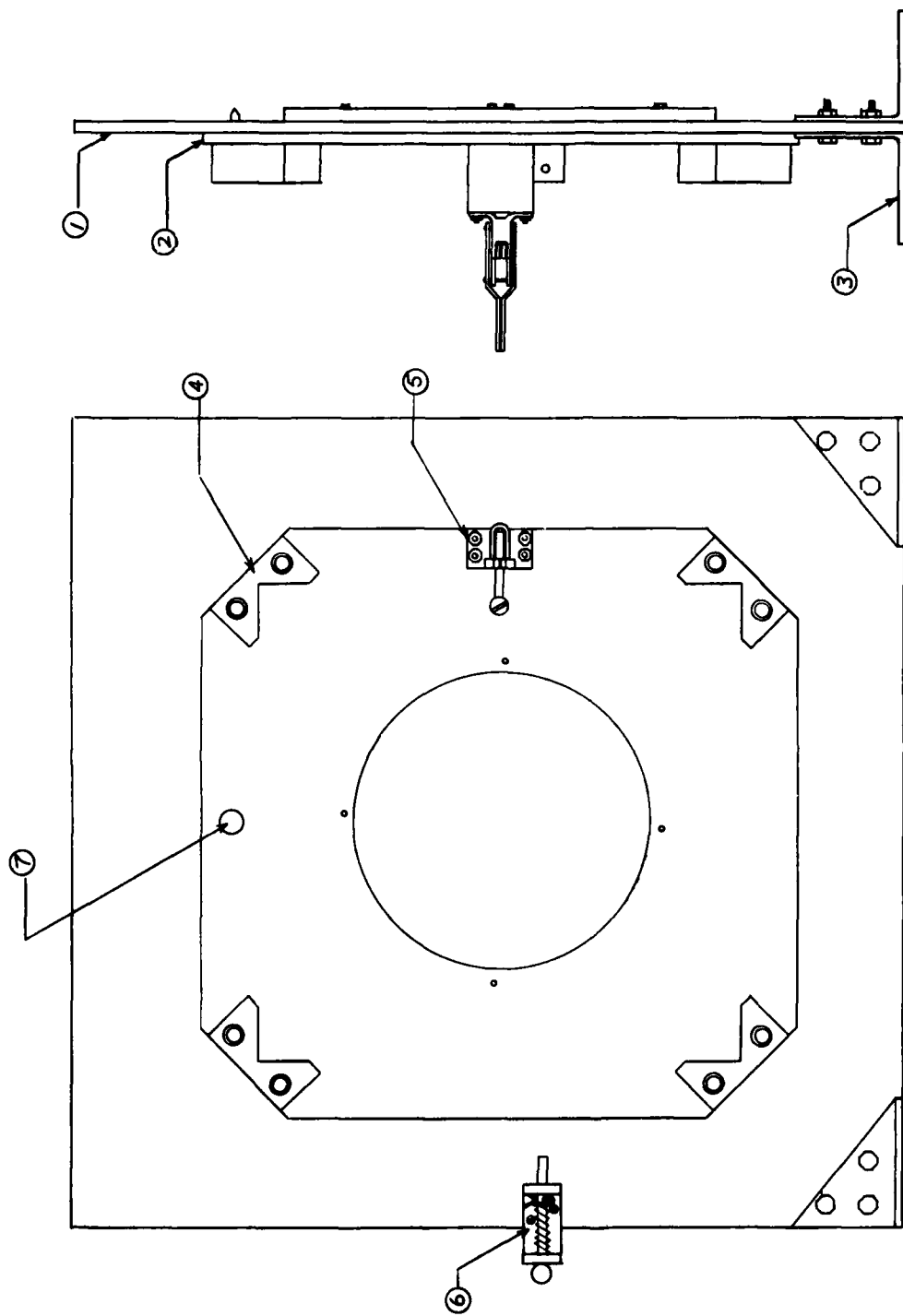

- 1 BASE
- 2 HOLDER MOUNT
- 3 FOOT
- 4 SUPPORT BLOCK
- 5 CLAMP
- 6 STOP
- 7 PIN

Figure A-1. Fabric Stand Assembly

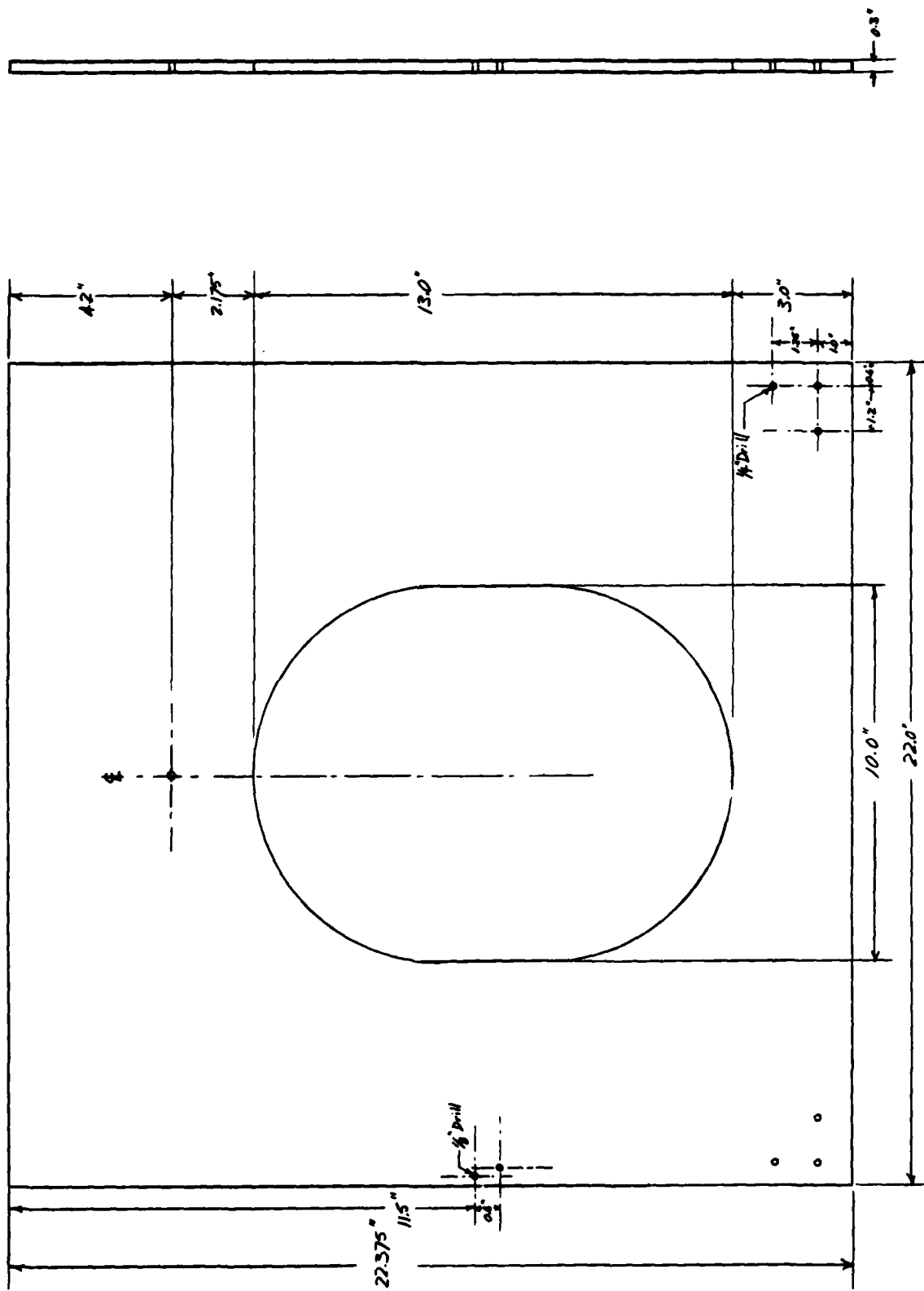

Figure A-2. Fabric Stand Base

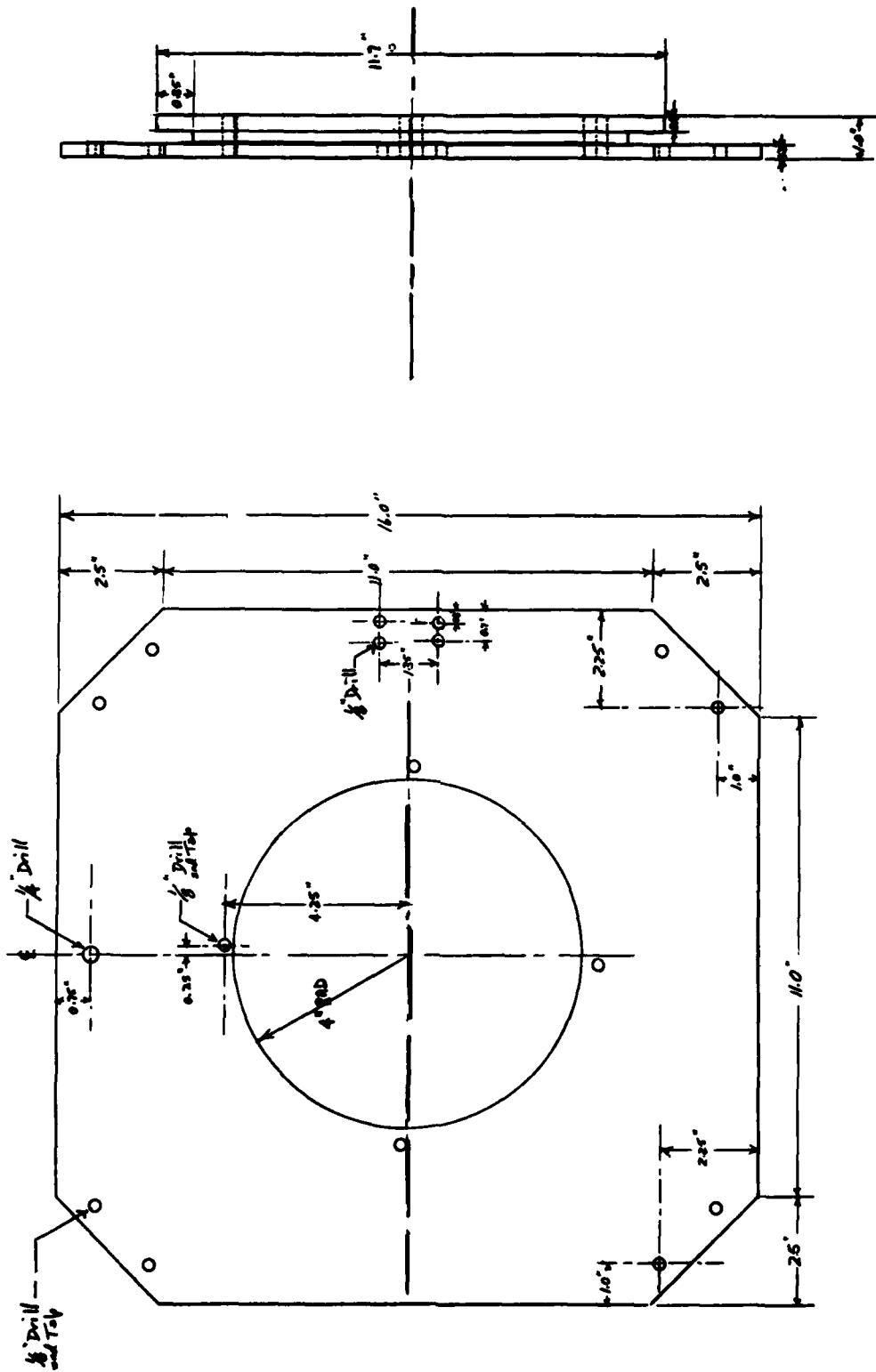

Figure A-3. Fabric Stand Holder Mount

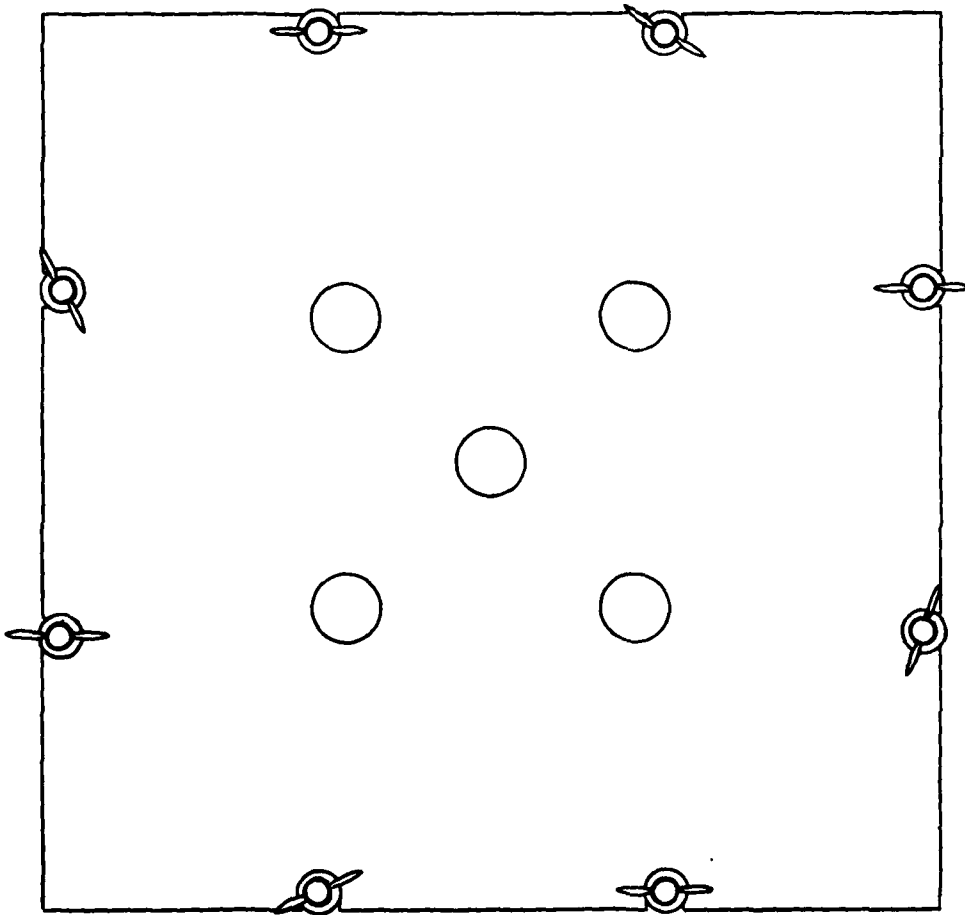
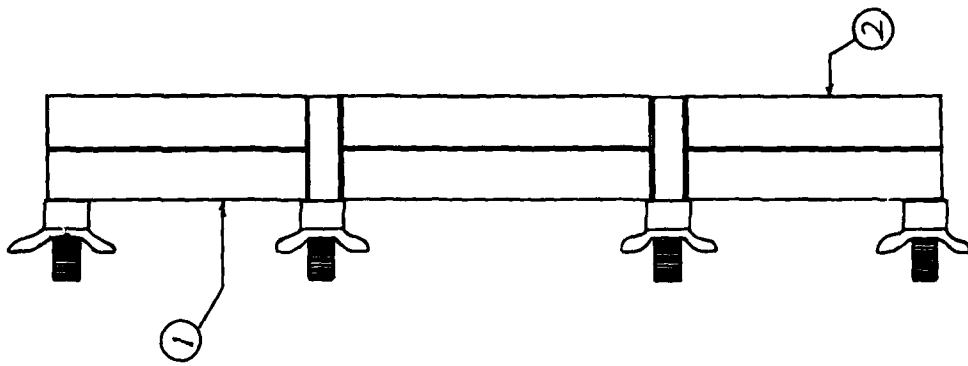

Figure A-4. Fabric Holder Assembly

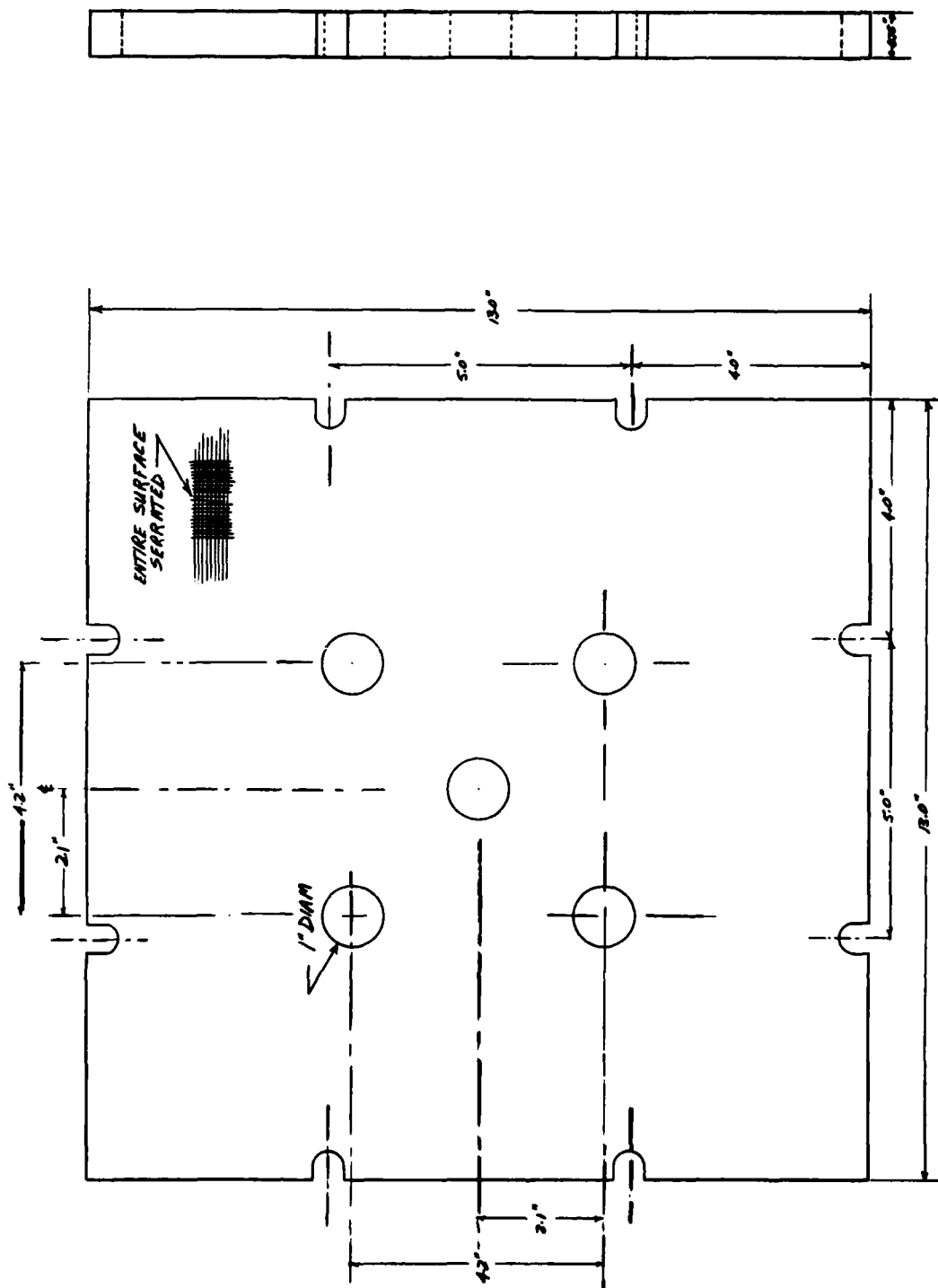

Figure A-5. Fabric Holder (Top Plate)



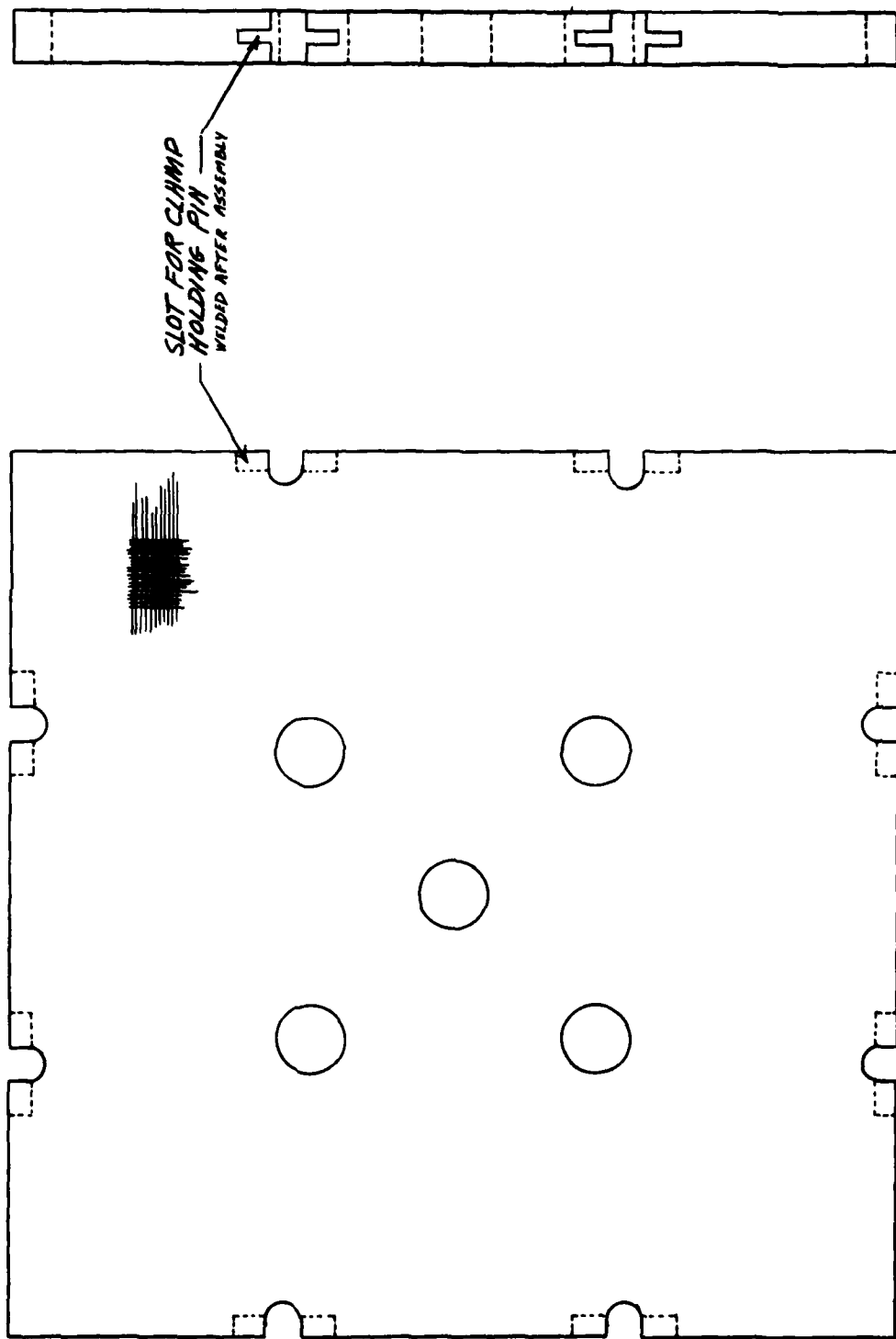

Figure A-6. Fabric Holder (Bottom Plate)