

REPORT DOCUMENTATION PAGE		READ INSTRUCTIONS BEFORE COMPLETING FORM
1. REPORT NUMBER	2. GOVT ACCESSION NO.	3. RECIPIENT'S CATALOG NUMBER
4. TITLE (and Subtitle) Life Study of RF Excited Hg Arc Lamps and CO <sub>2</sub> Waveguide Lasers		5. TYPE OF REPORT & PERIOD COVERED Annual Progress Report
7. AUTHOR(s) U. Hochuli		6. PERFORMING ORG. REPORT NUMBER
9. PERFORMING ORGANIZATION NAME AND ADDRESS Electrical Engineering Department University of Maryland College Park, MD 20742		8. CONTRACT OR GRANT NUMBER(s) N00014-79-C-0312
11. CONTROLLING OFFICE NAME AND ADDRESS ONR		10. PROGRAM ELEMENT, PROJECT, TASK AREA & WORK UNIT NUMBERS 61153N RR011-07-04 NR 379-042
14. MONITORING AGENCY NAME & ADDRESS (if different from Controlling Office)		12. REPORT DATE January 1985
		13. NUMBER OF PAGES 23
		15. SECURITY CLASS. (of this report) Unclassified
		15a. DECLASSIFICATION/DOWNGRADING SCHEDULE
16. DISTRIBUTION STATEMENT (of this Report) Approved for public release; distribution unlimited.		
17. DISTRIBUTION STATEMENT (of the abstract entered in Block 20, if different from Report)		
18. SUPPLEMENTARY NOTES		
19. KEY WORDS (Continue on reverse side if necessary and identify by block number) High Pressure Mercury Arc Lamp Electrodeless General Electric BH-6 Type 2.45 GHz RF excited CO <sub>2</sub> Waveguide Lasers, 2W CW, Lifetest results RF gas conductance measurements		
20. ABSTRACT (Continue on reverse side if necessary and identify by block number) An air cooled, electrodeless, high pressure Hg-arc lamp, excited with 800 W 2.45 GHz RF power, has delivered full output for the first 1000 hours. After 5000 hours, the 366 nm output power was 40 percent of the initial output. 140 MHz RF excited 2W CW CO <sub>2</sub> waveguide lasers have shown life of 10,000 to 20,000 hours. This result was achieved with CO as well as with N <sub>2</sub> bearing gas mixtures and for structures with internal electrodes as well as with capaci- tive wall coupling. One laser still had 60 percent of its original power left after 50,000 10-minute on-off cycles. Preliminary RF gas conductance		

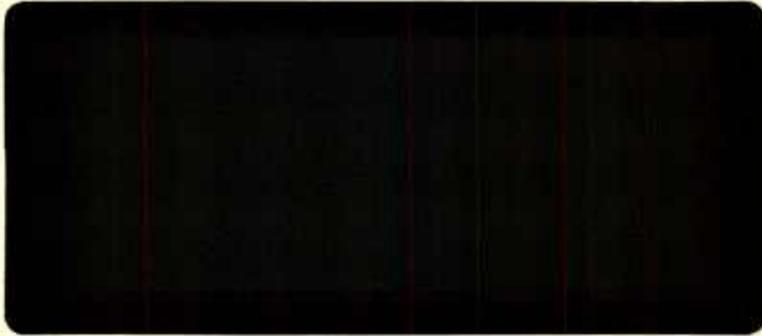

# Electrical Engineering Department

UNIVERSITY OF MARYLAND, COLLEGE PARK, MD 20742



// maryland, University.



COLLEGE OF ENGINEERING: GLENN L. MARTIN INSTITUTE OF TECHNOLOGY

LIFE STUDY OF RF EXCITED  
Hg ARC LAMPS  
and  
CO<sub>2</sub> WAVEGUIDE LASERS

N00014-79-C-0312

Progress Report

Submitted to

Dr. V. O. Nicolai  
ONR

by

U. Hochuli

January 1985

## Introduction

The development of a laser, from its invention to a practical and reliable device is an extremely difficult, time-consuming task. From the thousands of lasing transitions found, there are roughly a dozen commercially viable lasers available on the market. Thus, it is not surprising that the Navy's requirements for a practical and viable blue-green laser still has not been met more than twenty years after the invention of the first laser. All the suitable candidates seem to have difficulties that are hard to overcome, from the short life of the corrosive Hg-Br laser, the lack of suitable diode arrays to excite the frequency doubled Nd-Yag laser, to the missing crystal rod that could directly lase in the blue-green region of the spectrum. Work is being done in all of these areas, including the latter one, and progress is very slow. Although progress in the development of a suitable crystal is being made, it still requires a good excitation source. It has been shown (1) that the high pressure Hg-arc lamp can be excited to produce most of its output in the desired range around 3600 Å. However, the lifetime of these lamps is quite short, even under normal working conditions. We have started to look into this life problem and, at the same time, we are continuing our efforts to improve the life of the RF excited CO<sub>2</sub> laser. Fortunately, we can report excellent results in both of these areas.

## Hg-Arc Lamp

To our own surprise, we have been able to extend the life of a high pressure mercury arc lamp of the BH6 type, formerly manufactured by General Electric, by two orders of magnitude. As Figure 1 shows, our lamp still radiates 40 percent of its original power (at 3660 Å in the radial direction) after 5000 hours of service.

This result was achieved by using electrodeless 2.45 GHz microwave lamp excitation. Evidently, our previous assumption, that darkening of the lamp walls from electrode sputtering and successive wall temperature increase had to be avoided, was correct. The photographs in the appendix show that the lamp envelope hardly

undergoes any change during the first 1000 hours of its life. After 1500 hours, we start to observe a gradual transformation of the clear inside surface of the envelope into a frosty, snow-white band around the lamp's central region. At room temperature, condensed mercury droplets can still be observed after 5000 hours of service. It is, of course, difficult to judge if the total amount of liquid mercury still amounts to the original 13 mg or if some mercury has been transformed into other mercury compounds. A suitable explanation of why the 3660 Å power output dropped to 40 percent for the same input power will be addressed in the next phase. Comparison with a new lamp will reveal whether the spectral power distribution has changed or if the walls are simply less transparent to or scatter more of the 3660 Å radiation.

We definitely had to spend more time for maintaining the equipment than we expected. Breakdowns occurred in the water chiller used to cool the waveguide walls and in most of the safety circuits, from the reflected power meter to the water flow monitoring switches in the transmitter. Replacement of the switches only cured the problem for two additional months, and we finally had to redesign them ourselves. The starter switch of the air compressor did not last either, and finally the compressor itself failed. The replacement compressor has thus far worked but produces so much more water and oil in the air line that one of our fine filters was destroyed. A dryer has now been installed in the air line.

All in all, the mercury arc lamp worked only about half of the time and had to be restarted more than 50 times over the 5000-hour period monitored by an hour meter.

Our CW test results are unquestionably excellent. Nevertheless, we realize that it will take considerably more effort to match the discharge to the proper pulse source. This source will have to keep the discharge alive at the 500 W power level and also feed it with several microsecond-long 1 MW microwave power pulses for a total input power of nearly 1 KW.

Very little knowledge is available on the DC discharge mode and even less on the transient pulsed mode. However, we do know that during the pulse mode, the plasma impedance decreases and the plasma current increases by two or three order of magnitude. Whether or not reasonable matching conditions can be maintained during this process remains to be seen. It may even be necessary to cool the arc lamp with fluorocarbon liquid in order to avoid air breakdown problems.

Lack of approval for equipment funding has thus far prevented us from running the arc lamp in a pulsed mode.

Instead, we have tried to get a feeling for the matching problem by trying to solve the simpler boundary value problem of a conducting cylinder, with top and bottom air gaps, at the origin of a radial transmission line. This requires one-dimensional matching with eigenmodes that are not orthogonal. The field solution is not convergent due to the sharp edge of the conducting cylinder. An alternate approach was tried by placing the lamp along the axis of a cylindrical resonator. Galerkin's eigenmode expansion has the advantage of dealing with the orthogonal eigenmodes of the empty lossless cavity and the disadvantage of dealing with modes in two dimensions. This rapidly leads to very large matrices and does not avoid the singularity of the sharp edge of the conducting cylinder. This singularity can be avoided by rounding the cylinder edge, which leads to much more complicated calculations, or by arbitrarily breaking of the expansion. At the present time, we do not have sufficient confidence in the latter approach.

However, the calculations show that ohmic contacts are required to maintain the current flow in the axial direction. This flow sustains the TEM mode responsible for the uniform radiation pattern we observe in the electrode-fed DC or 60 Hz discharge. Figure 2 compares the relative, radially radiated power output measured along the axis of the 60 Hz electrode-excited lamp with the one obtained from the electrodeless 2.45 GHz excited lamp.

Axial current flow at 2.45 GHz requires planar electrodes and not long, thin, ribbon feed-through connections with their large impedances. Such planar electrodes are very hard and perhaps impossible to achieve with quartz envelopes that have to work with internal pressures up to 4500 PSI and are at the same time subject to a tremendous temperature gradient across the walls.

### CO<sub>2</sub> Laser Research

At the present time, we are able to produce RF excited 2 to 3W CW CO<sub>2</sub> waveguide lasers with lifetimes of the order of 10<sup>4</sup> to 2.10<sup>4</sup> hours. These results have been achieved with CO and N<sub>2</sub> bearing gas mixtures and with internal as well as external discharge electrodes. It should be carefully noted that these tests have been conducted with unstabilized lasers which drift around in their signatures. For this reason, the average power output was reduced to about one-half of the highest peak power output in the signature.

A very important contribution is the fact that one of the lasers, #1.1, still shows 60 percent of its original output power after it was cycled on and off every ten minutes for more than 50,000 cycles.

We have also begun to measure the starting voltage and driving point impedance of the RF excited gas discharge structure for different gas pressures and mixtures. This type of data will later serve as a basis for the matching and starting network optimization.

### LIFE TEST RESULTS

Life test results are shown in Figures 3 to 10, and the design parameters of the lasers involved are shown in Table 1. Failure analysis results of some of the lasers, such as laser #8, which could not be restarted, will follow in our next report.

We have come to the conclusion that a proper failure analysis requires complete gas analysis results and should cover all of the original mixture

constituents as well as possible impurities, such as  $H_2O$ . This analysis has to be performed in suitable intervals as the laser ages. Proposals for purchasing the required equipment to accomplish this task have been submitted.

#### RF IMPEDANCE MEASUREMENTS

These measurements are intended to furnish data that will serve as a basis for the matching and starting network calculations.

#### TEST PROCEDURES

The actual laser discharge is first matched with a helical auto-transformer and  $\pi$ -network to the 50 ohm line. Matching is achieved by adjusting the  $\pi$ -network until the apparent SWR on the slotted line is better than 1.01 for each given input power level. Figure 11 shows the equipment used for this measurement. The auto-transformer is then removed from the laser and attached to a test fixture that closely duplicates the laser structure and brings the driving point connection out through the HP 11566A 10 cm precision airline as shown in Figure 12. Photographs of the coupling networks, test fixture, and laser with observation window are shown in the appendix.

Both the  $\pi$ -network and 10 cm airline have APC-7 precision connectors that serve as the two reference planes for the S-parameter measurements. These measurements are performed on HP 8409 or HP 8510 network analyzers.

The four S-parameters allow one to calculate the efficiency, driving point voltage, and impedance of the network at the input power level that the network was tuned for. Figures 13 and 14 show the preliminary curves of the input conductance for two different gas mixtures.

The calculated voltage is then used to calibrate the voltage measured with the probe of an HP 8405A vector voltmeter. This probe is coupled through stray capacitance to the driving point of the laser as indicated in Figure 10. This calibrated probe can now be used to measure the voltage required for starting the discharge.

Figures 15 and 16 show this starting voltage and the minimum power required to spread the discharge over the full bore length for different pressures and gas compositions.

#### MEASUREMENT ACCURACY

We have varied each one of the amplitudes and phases individually in order to determine how much S-parameter amplitude and phase errors affect the calculated load impedance and network efficiency. Data for variations around a set of four typical S-parameters is presented in Table 2. These results show that the  $S_{21}$  parameter's amplitude precision is extremely important. Our variation of 0.1 db is realistic and perhaps even optimistic in view of the fact that the National Bureau of Standards is capable of measuring  $S_{12}$  and  $S_{21}$  parameters with 0.03 db and  $S_{11}$  and  $S_{22}$  parameters with 0.05 db precision. The network analyzer's source mismatch and a network that has to be measured under almost totally reflecting conditions are the main causes for this error.

It can be shown that errors caused by the remaining SWR after tuning the networks are less important.

We have also measured the current waveform through a test discharge tube. The tube was designed with two parallel, 20 mm long, 1.5 mm nickel wire electrodes, with 3.5 mm center-to-center spacing. Its gas filling consisted of 125 torr He:CO<sub>2</sub>:CO:Xe in the ratios 3:1:1:0.25. A parallel inductance tuned out the capacitive current through the 2 pf electrode capacitance.

The 70 MHz discharge current waveform is shown in Figure 17 and clearly indicates some distortion in the peaks. Figure 17 also shows that this mostly odd order harmonic distortion is not present in the transmitter output. Because of this inherent distortion, it does not make sense to spend a great deal of effort to further reduce the network analyzer errors.

#### NETWORK EFFICIENCY

Lack of impedance data forced us to design our network empirically. Our

choice of reasonably good components generally resulted in network efficiencies on the order of 80 percent to 90 percent. We have also found that large circulating currents are sometimes present, which will lower the efficiency to 70 percent or less. This result was not simply due to network analyzer error as there was a substantial temperature rise of some of the network components. This can be seen in the photograph in the appendix which shows the discolored, oxidized, tin-plated copper coil in the  $\pi$ -network. The input power used was only 30 watts at 140 MHz. This result should serve as a warning that an improperly designed network, placed inside the laser and surrounded by the gas mixture, can actually reduce the laser life by consuming oxygen for its oxidation.

We have found that minor design changes, such as varying the tap of the auto-transformer by a fraction of a turn, can improve the efficiency to an acceptable value.

#### References

P. Dal Pozzo, R. Polloni, and O. Svelto, Appl. Phys. 6, 1975.

Electrodeless B-H6 Hg-Arc Lamp  
Filling: 13 mg Hg, 20 Torr A  
Power Input: 800 W at 2.45 GHz; Airflow: 9 l/s

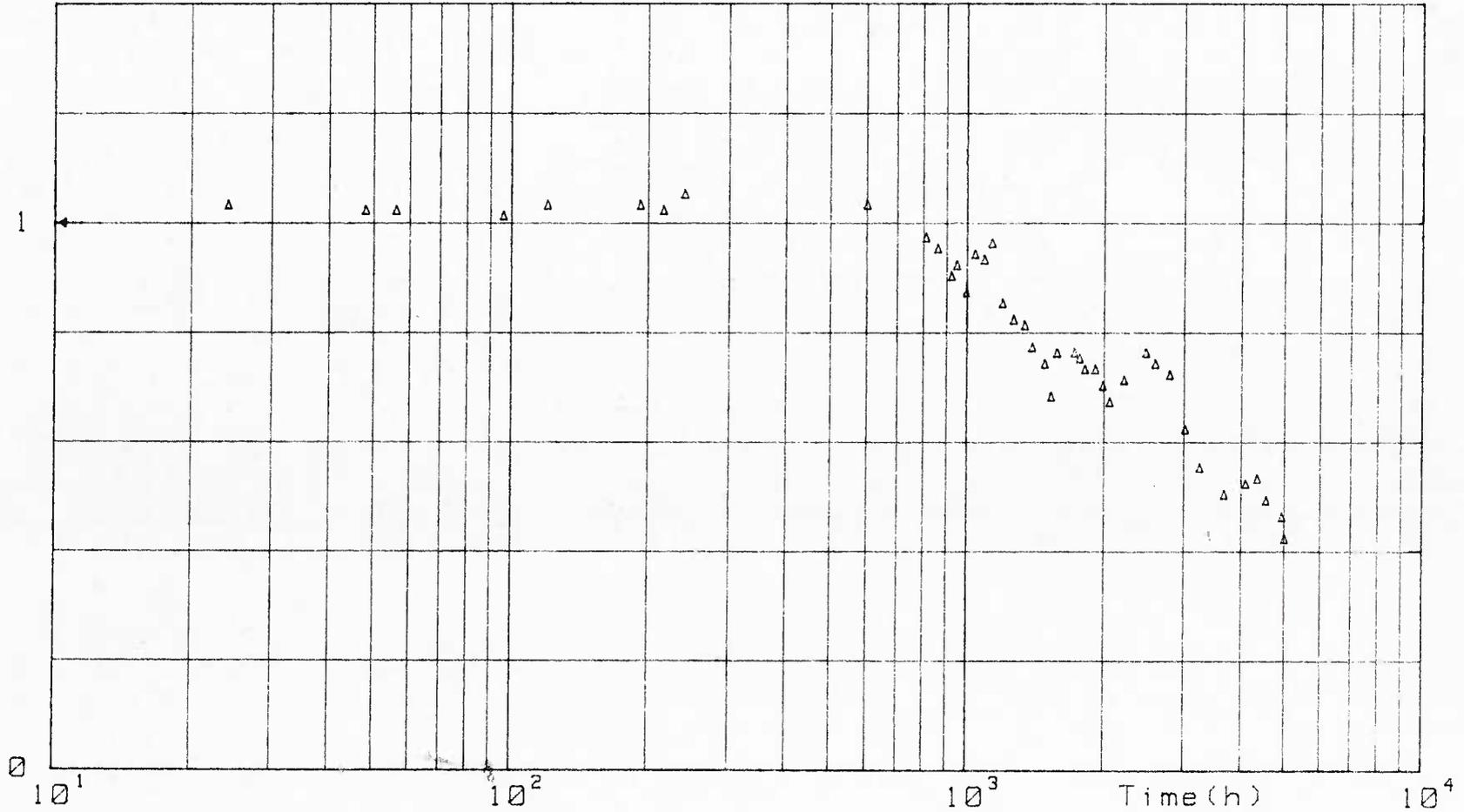
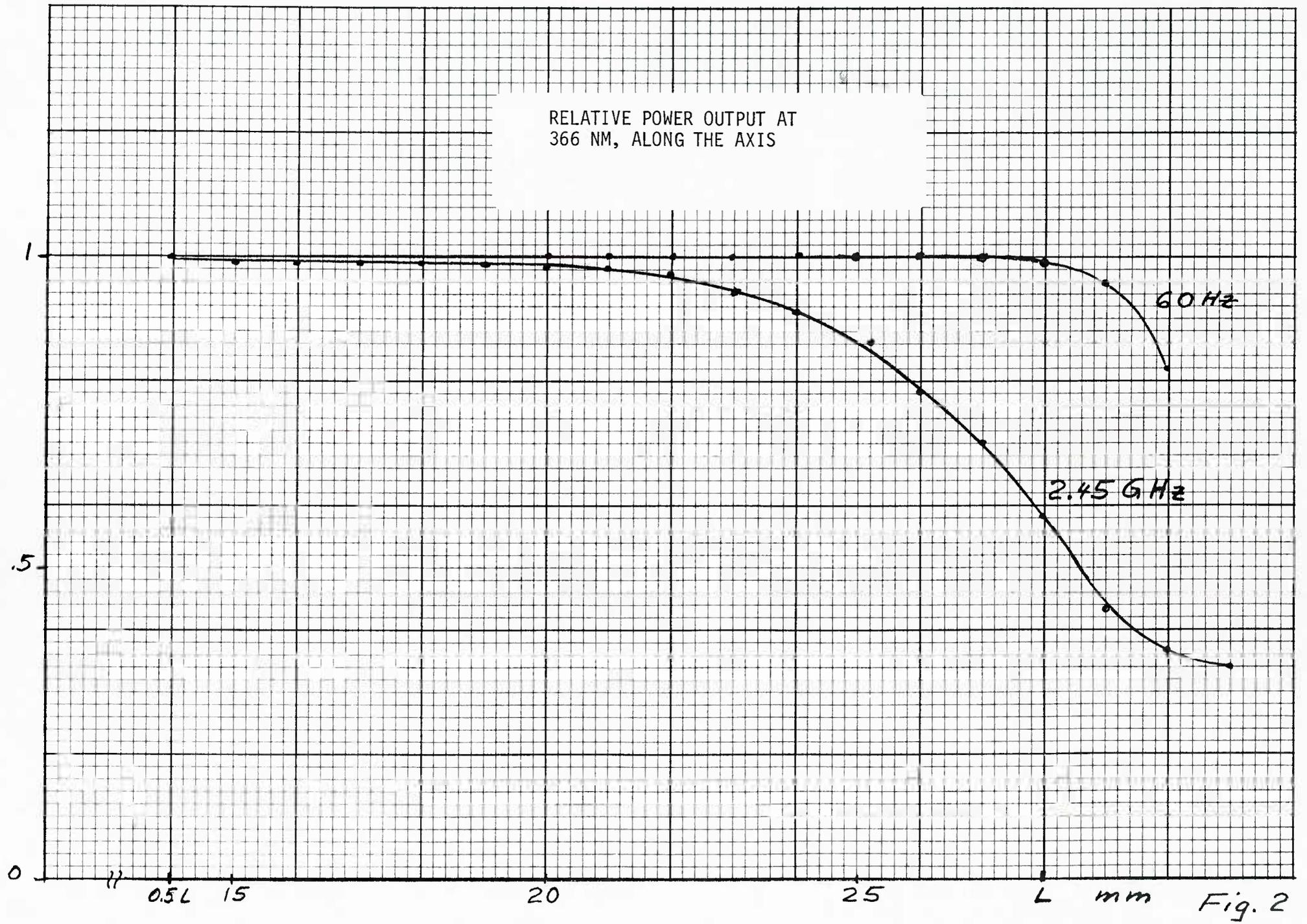

Fig.1, Normalized 366 nm Output Power vs Time

RELATIVE POWER OUTPUT AT  
366 NM, ALONG THE AXIS



60 Hz

2.45 GHz

Fig. 2

Laser#1.1

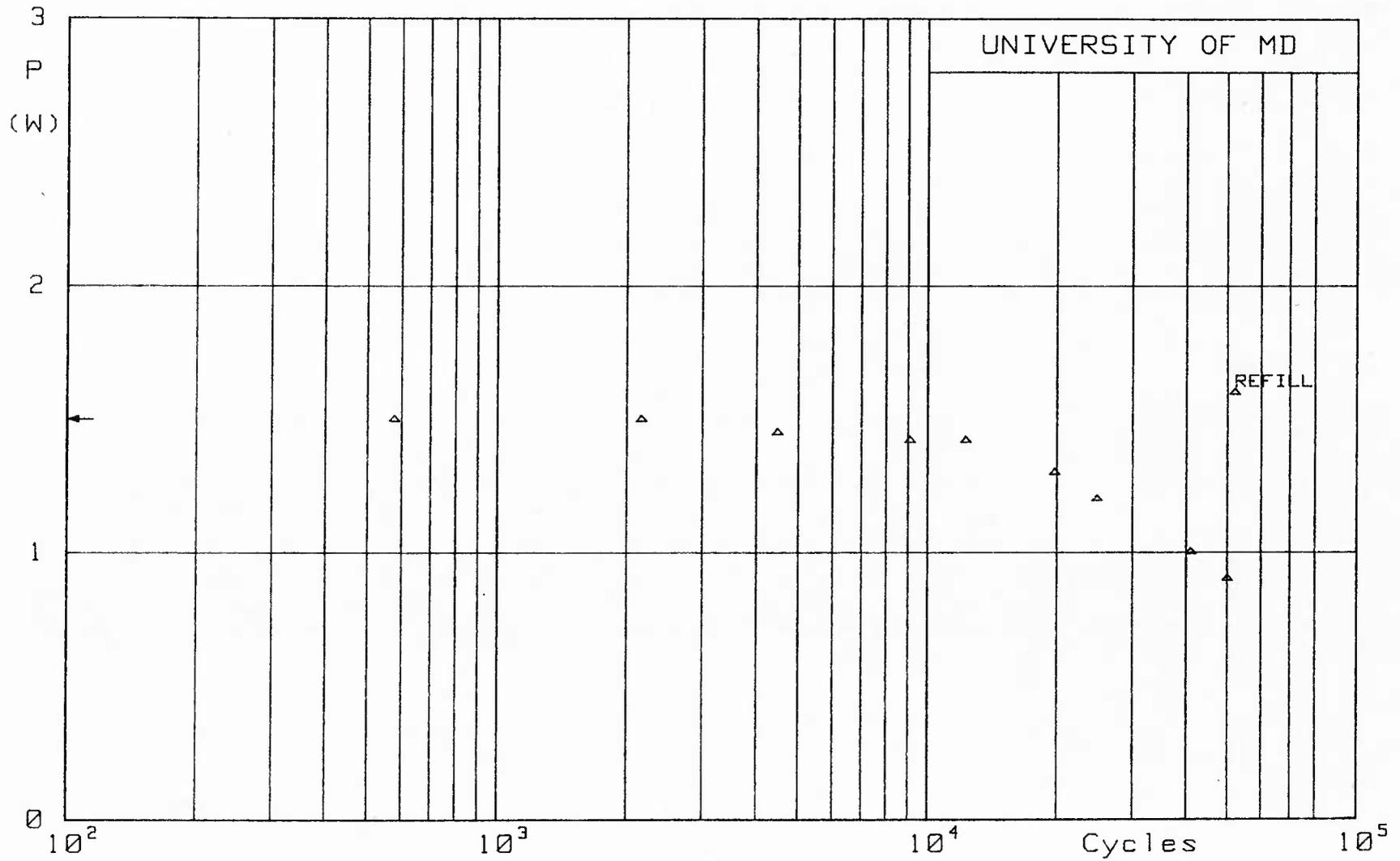

Fig.3 ,Power Output vs # of Cycles (5 min.ON,5 min.OFF)

Laser #2

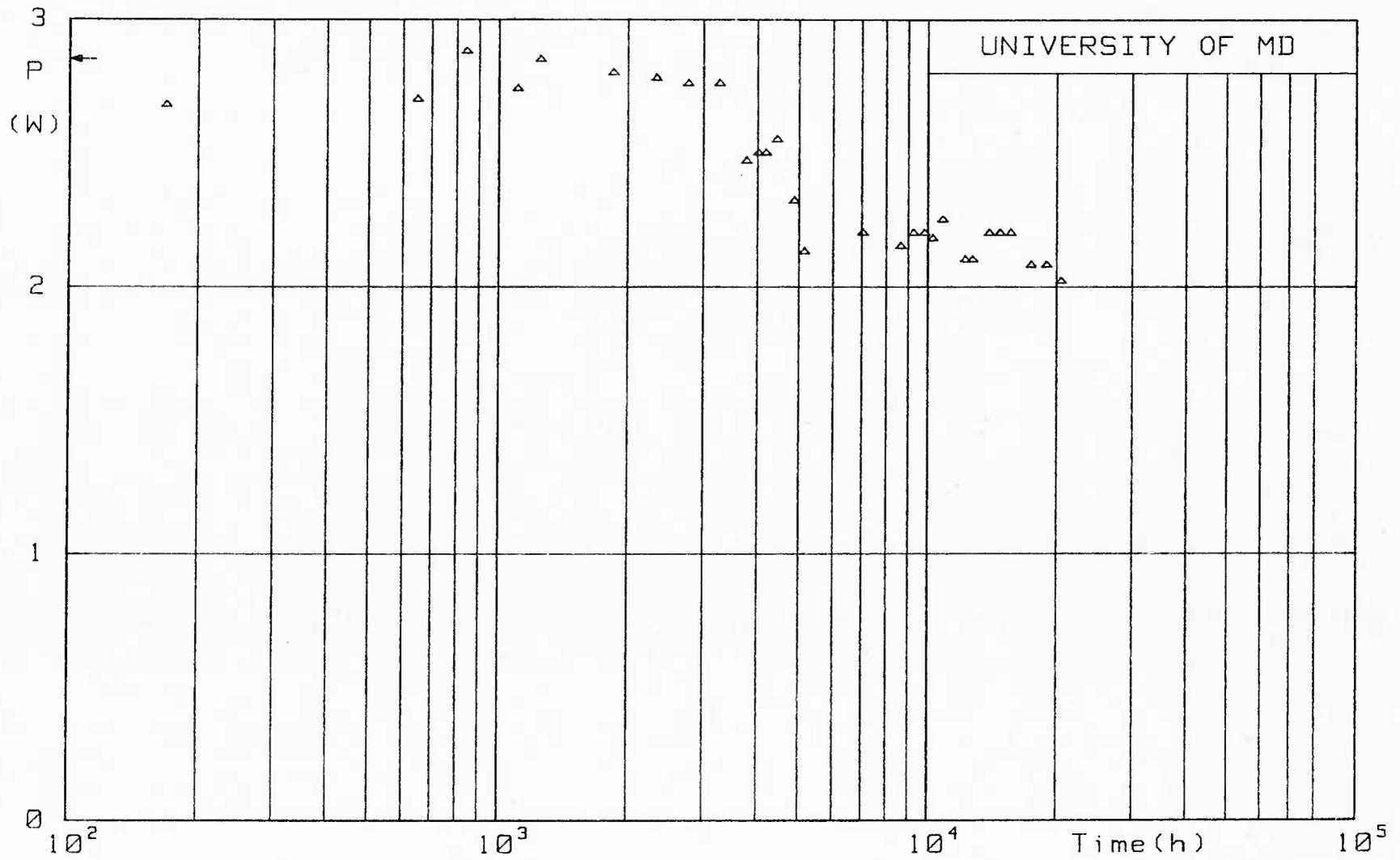

Fig.4 , Output Power vs Time

Laser#5

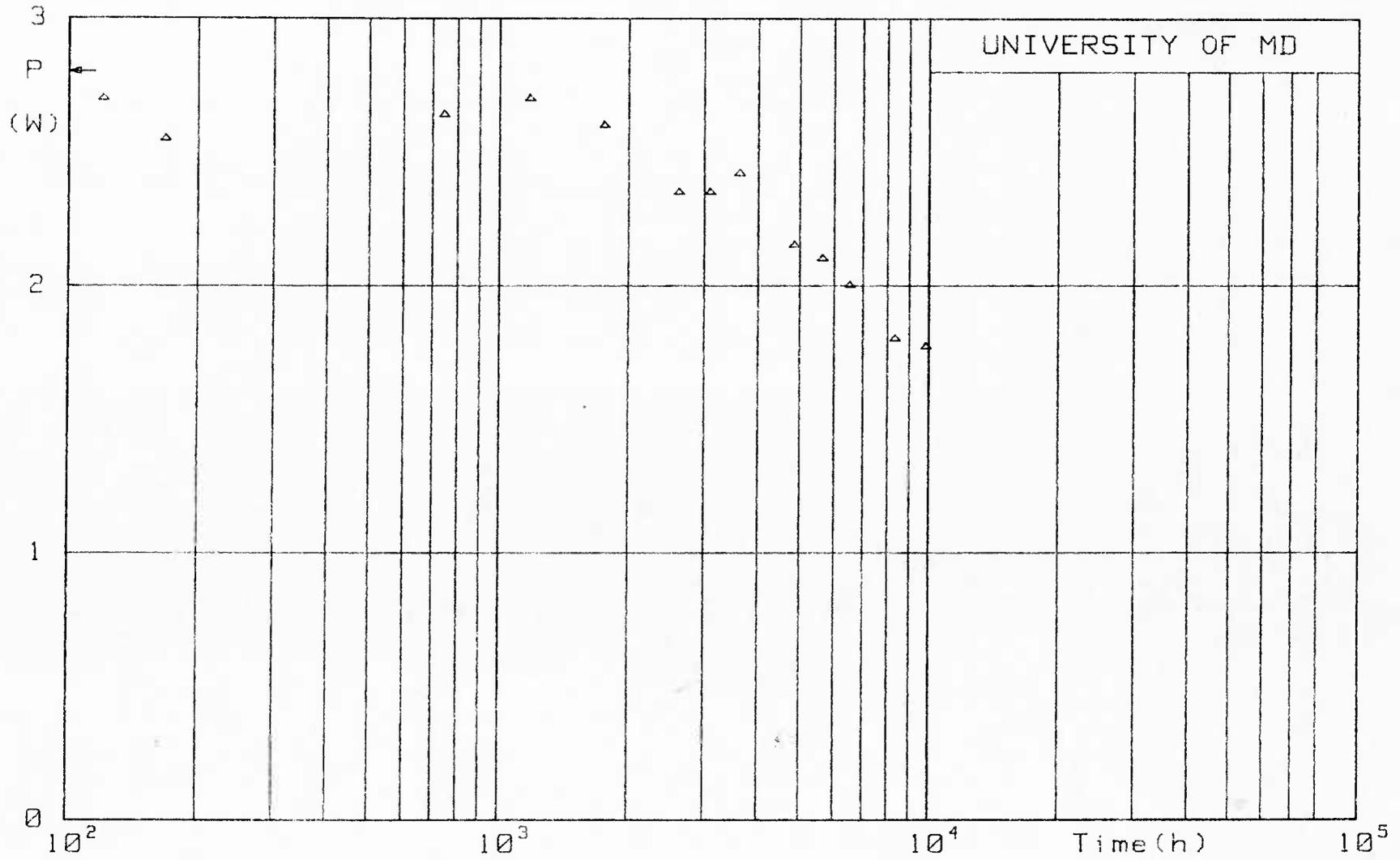

Fig.5 , Output Power vs Time

Laser #6

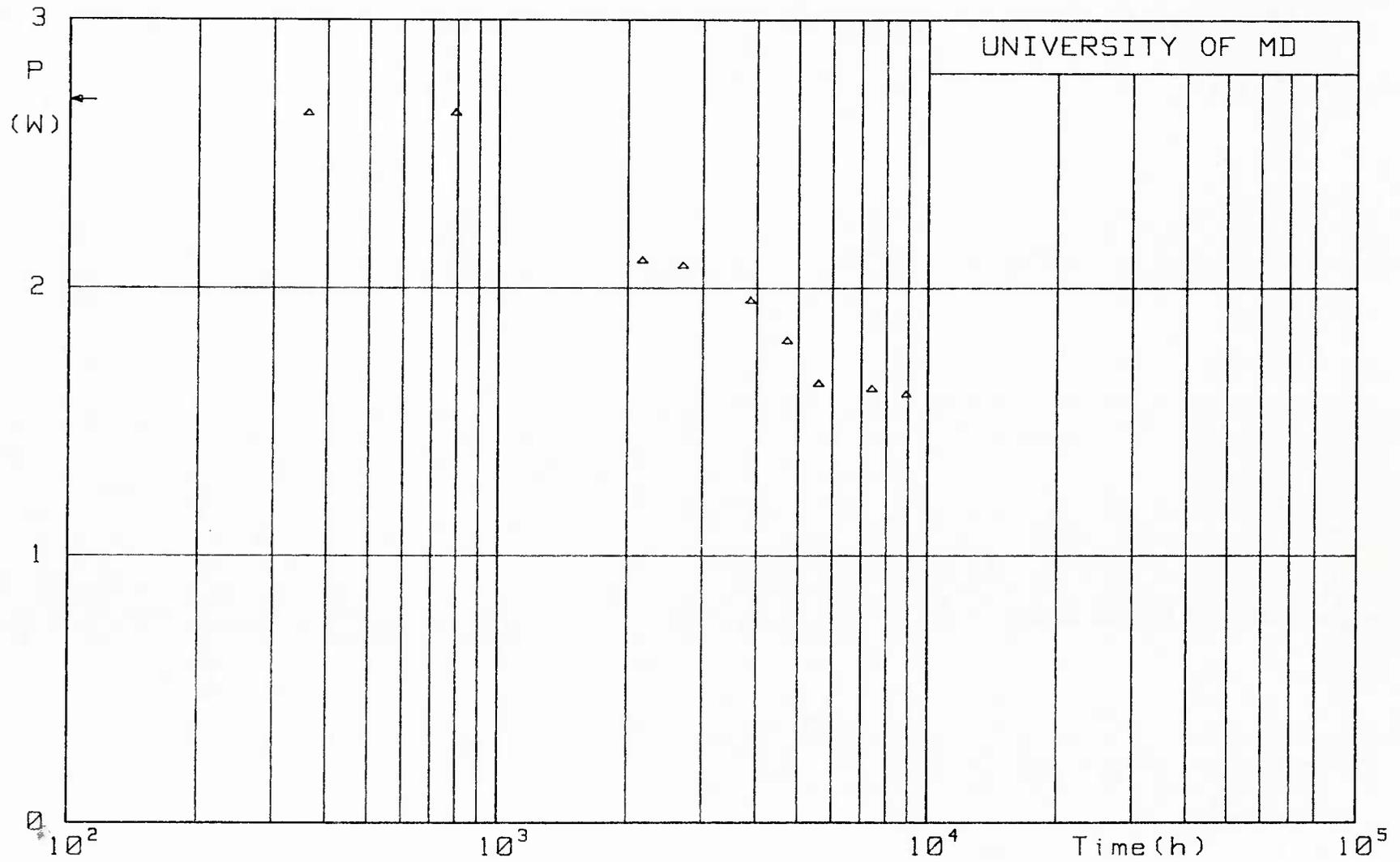

Fig.6 , Output Power vs Time

Laser#7.1

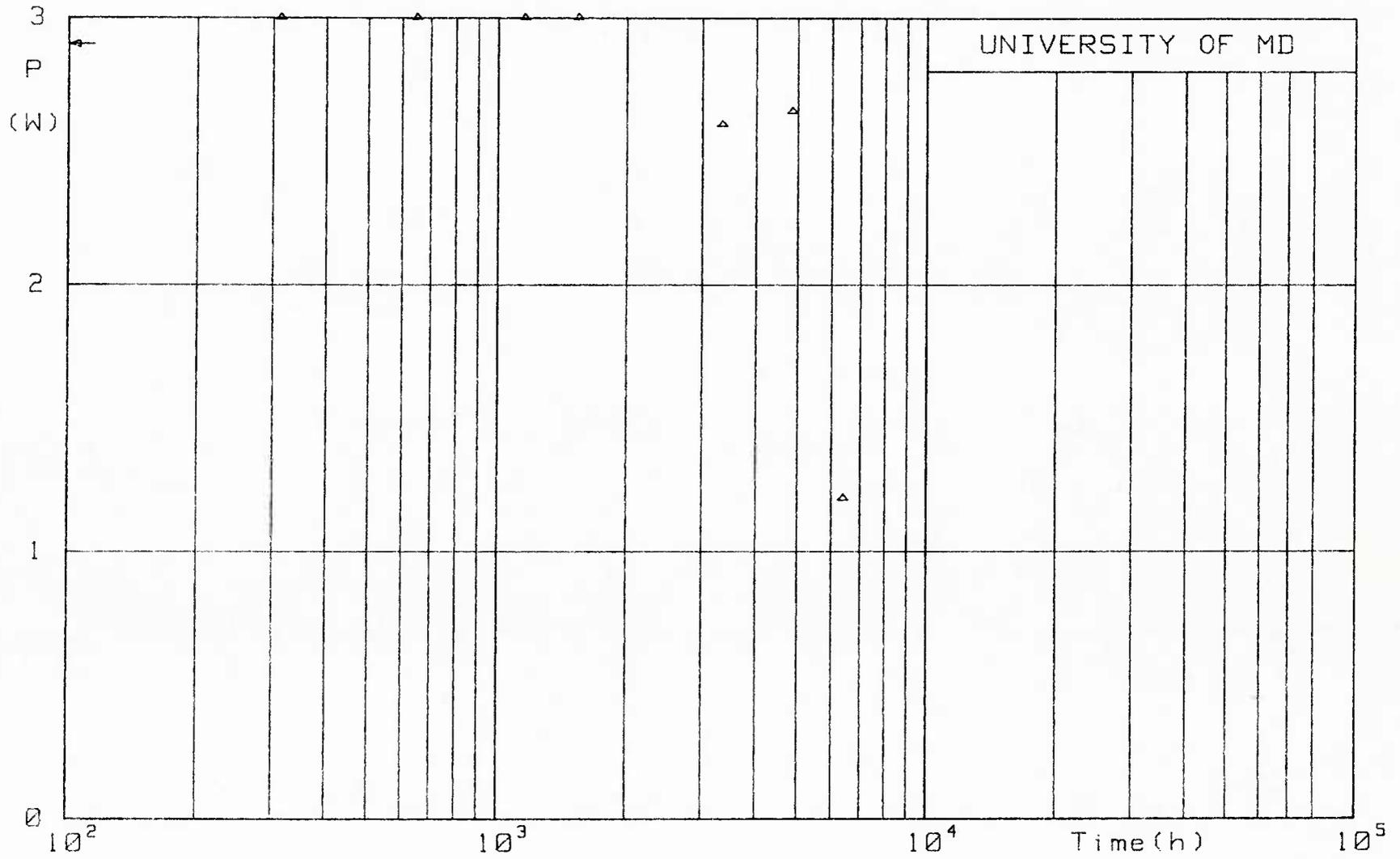

Fig.7 , Output Power vs Time

LASER#8

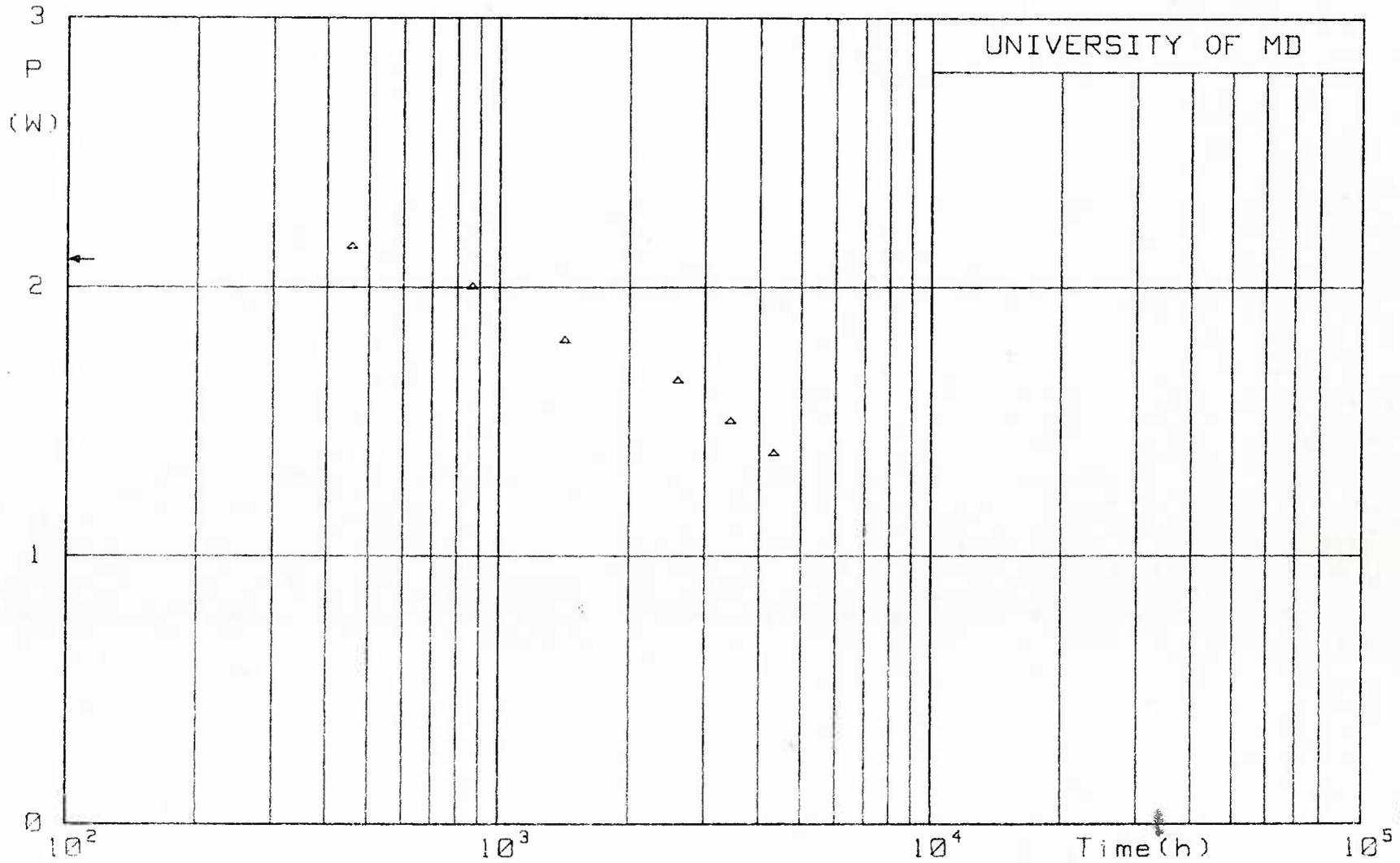

Fig.8 , Output Power vs Time

# Laser #9

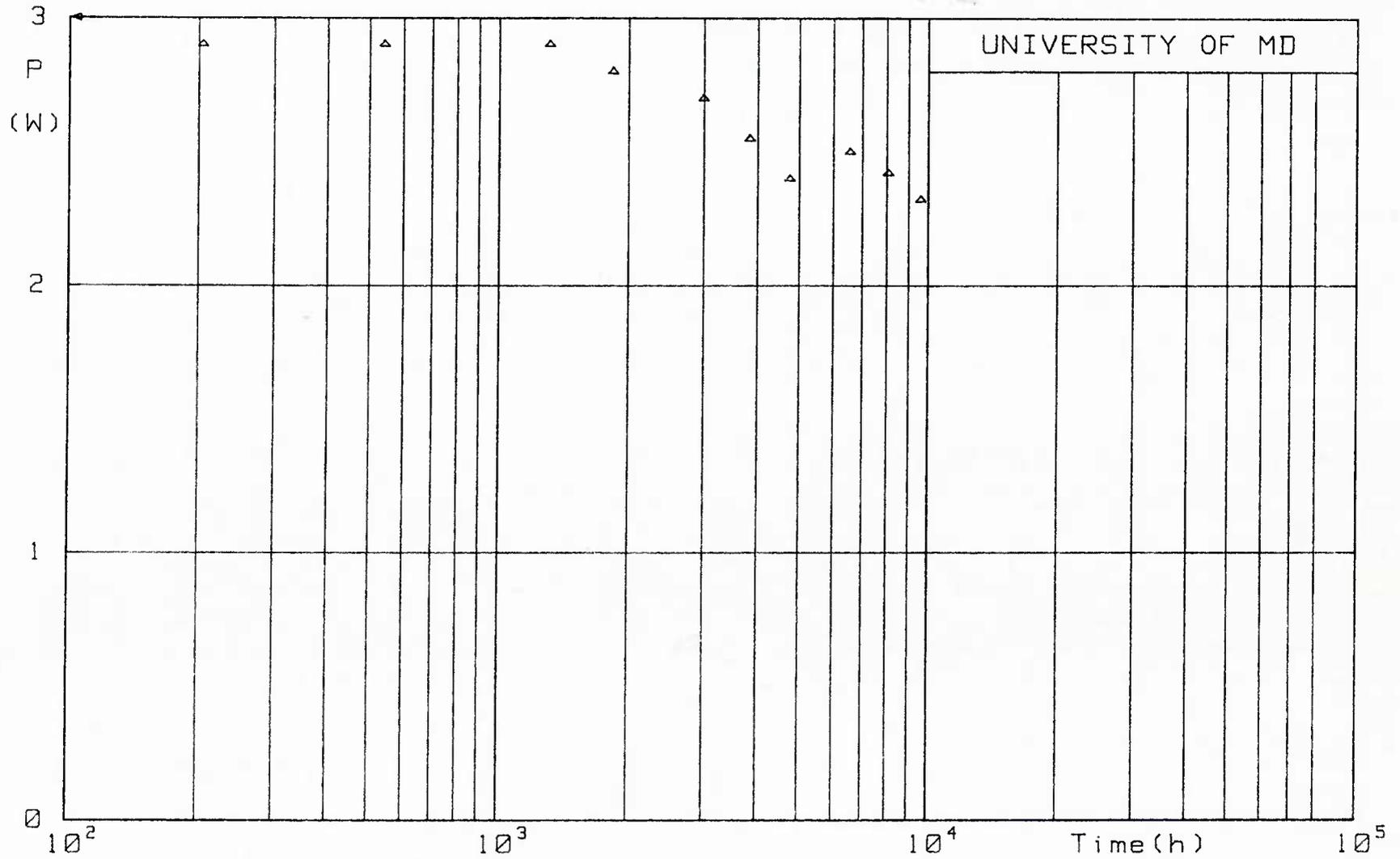

Fig.9 , Output Power vs Time

Laser#10

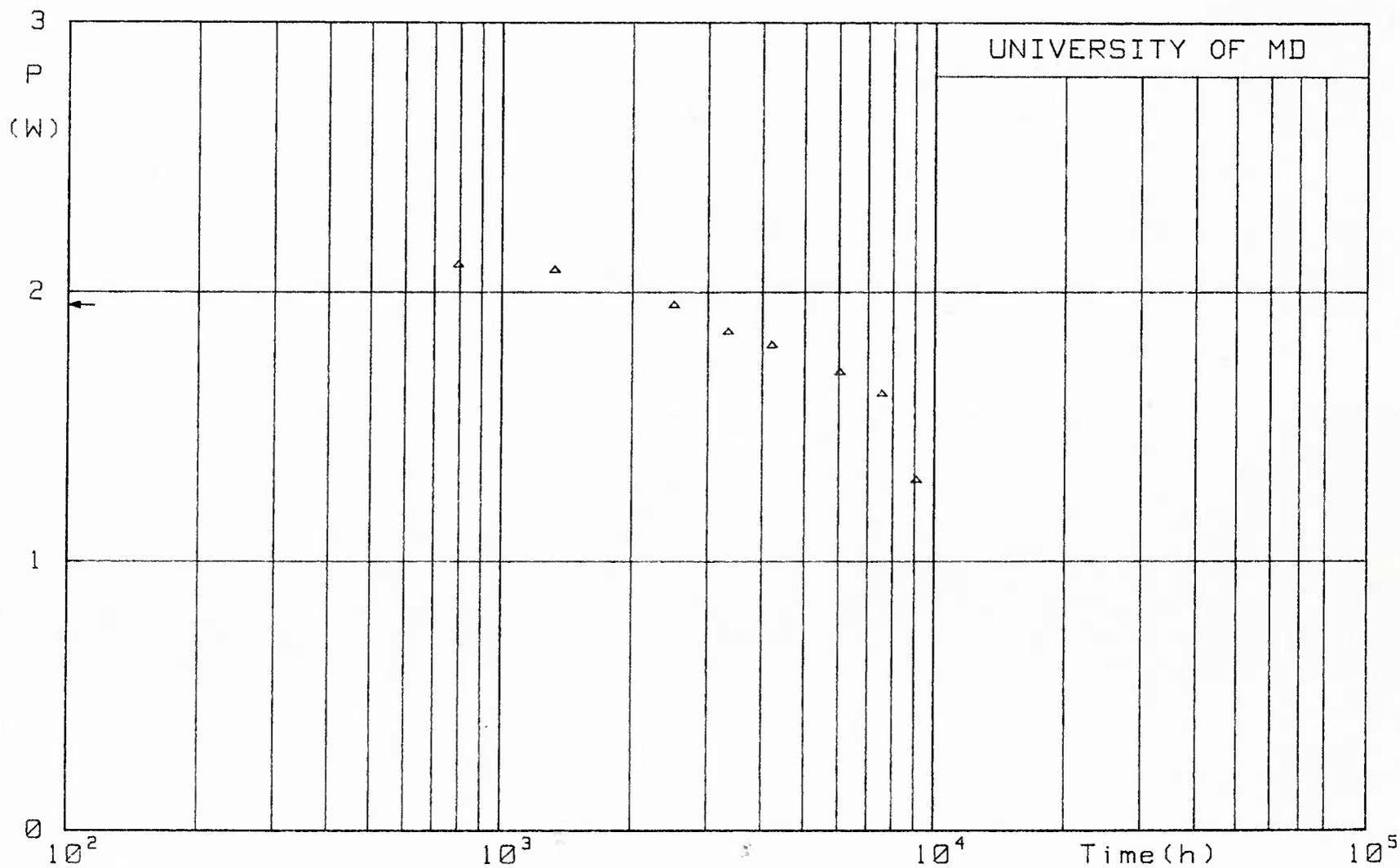

Fig.10, Output Power vs Time

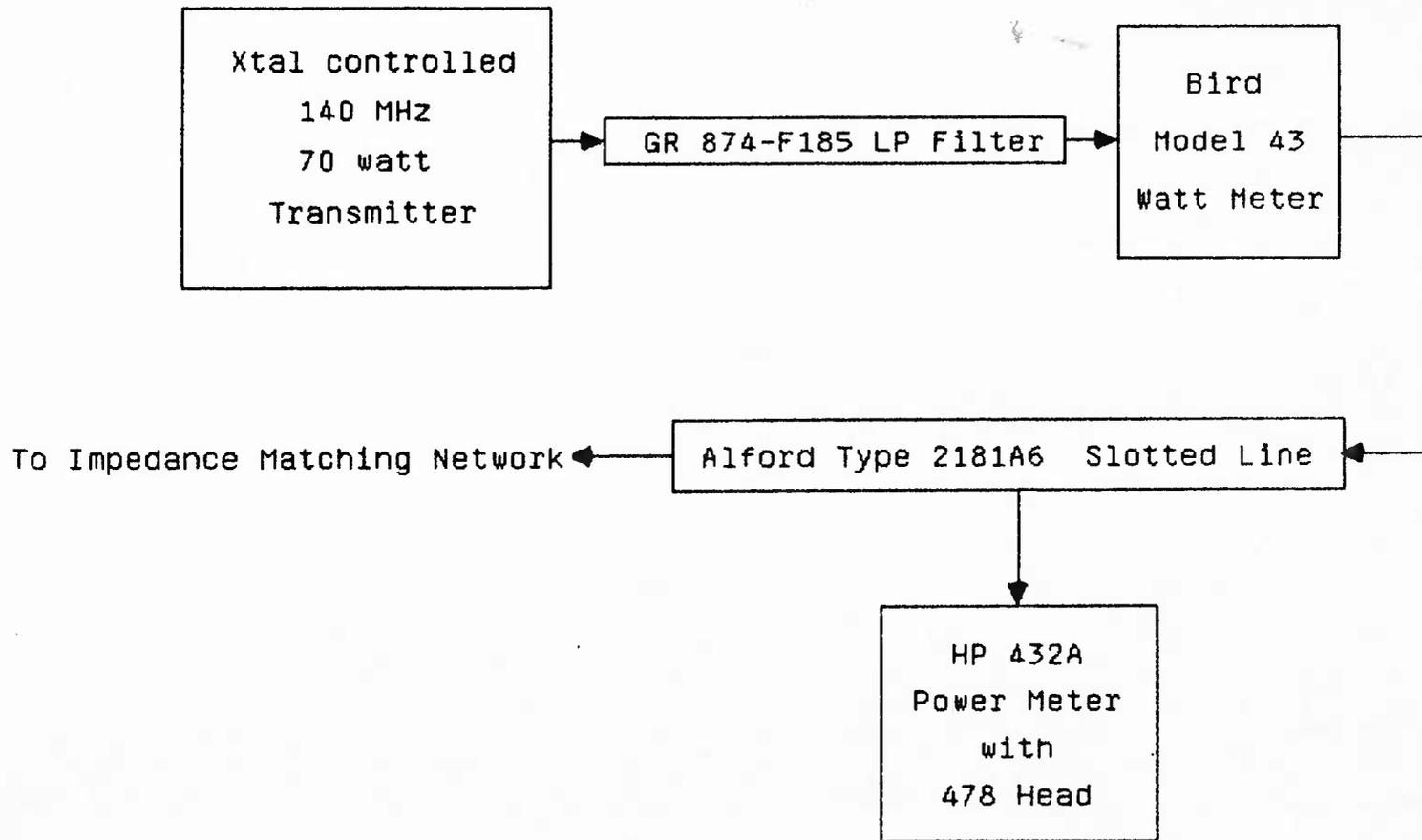

Figure 11 , Equipment configuration for SWR measurement

# Plasma Impedance Measurement

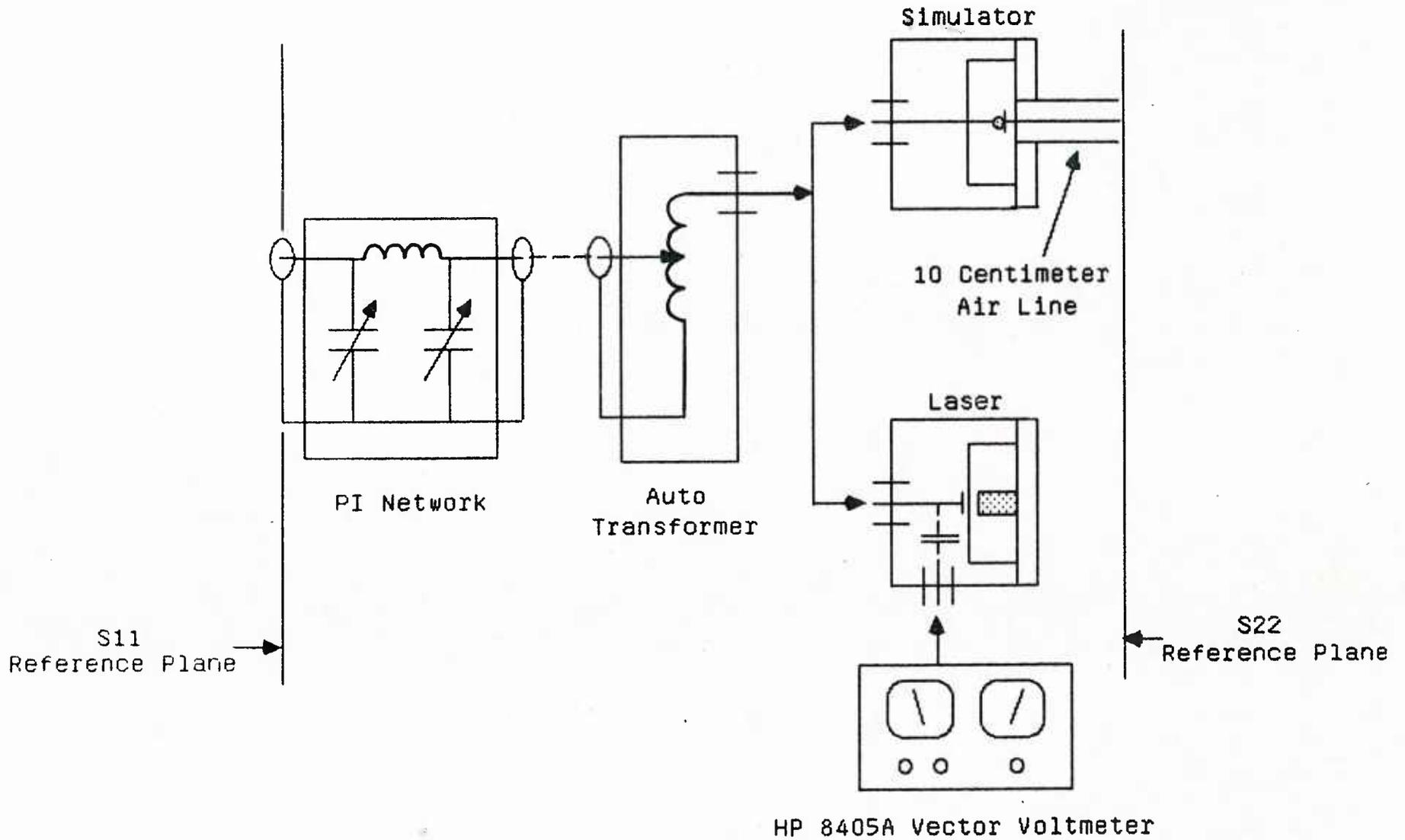

Figure 12 , Experimental Setup

He:CO<sub>2</sub>:CO:Xe ; 3:1:1:.25

Laser bore:1.5mm wide,1.65mm high,152.4mm long,127mm center-excited at 140 MHz

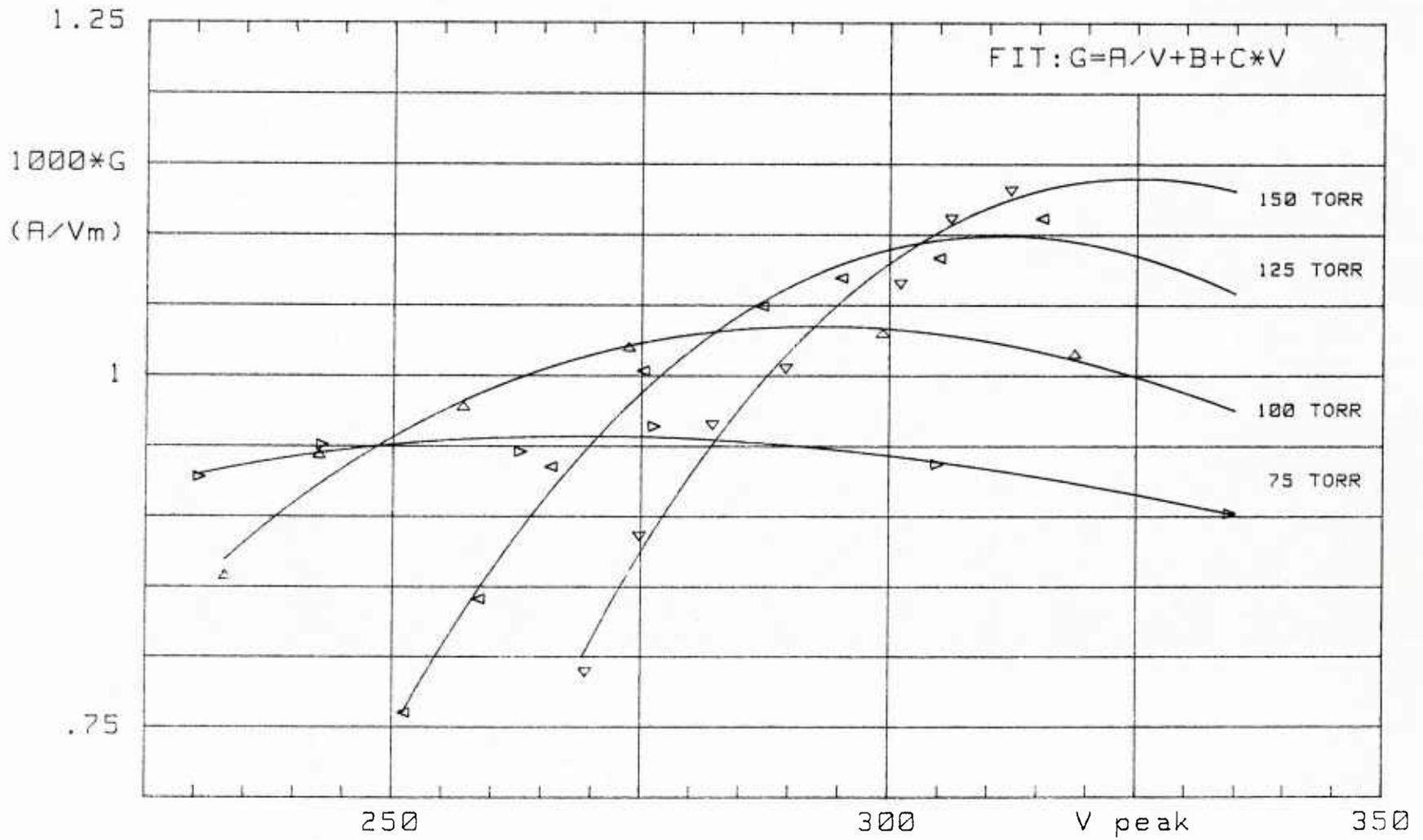

Fig.13, CENTER RF-CONDUCTANCE

He:CO<sub>2</sub>:N<sub>2</sub>:Xe ; 3:1:1:.25

Laser bore:1.5mm wide,1.65mm high,152.4mm long,127mm center-excited at 140 MHz

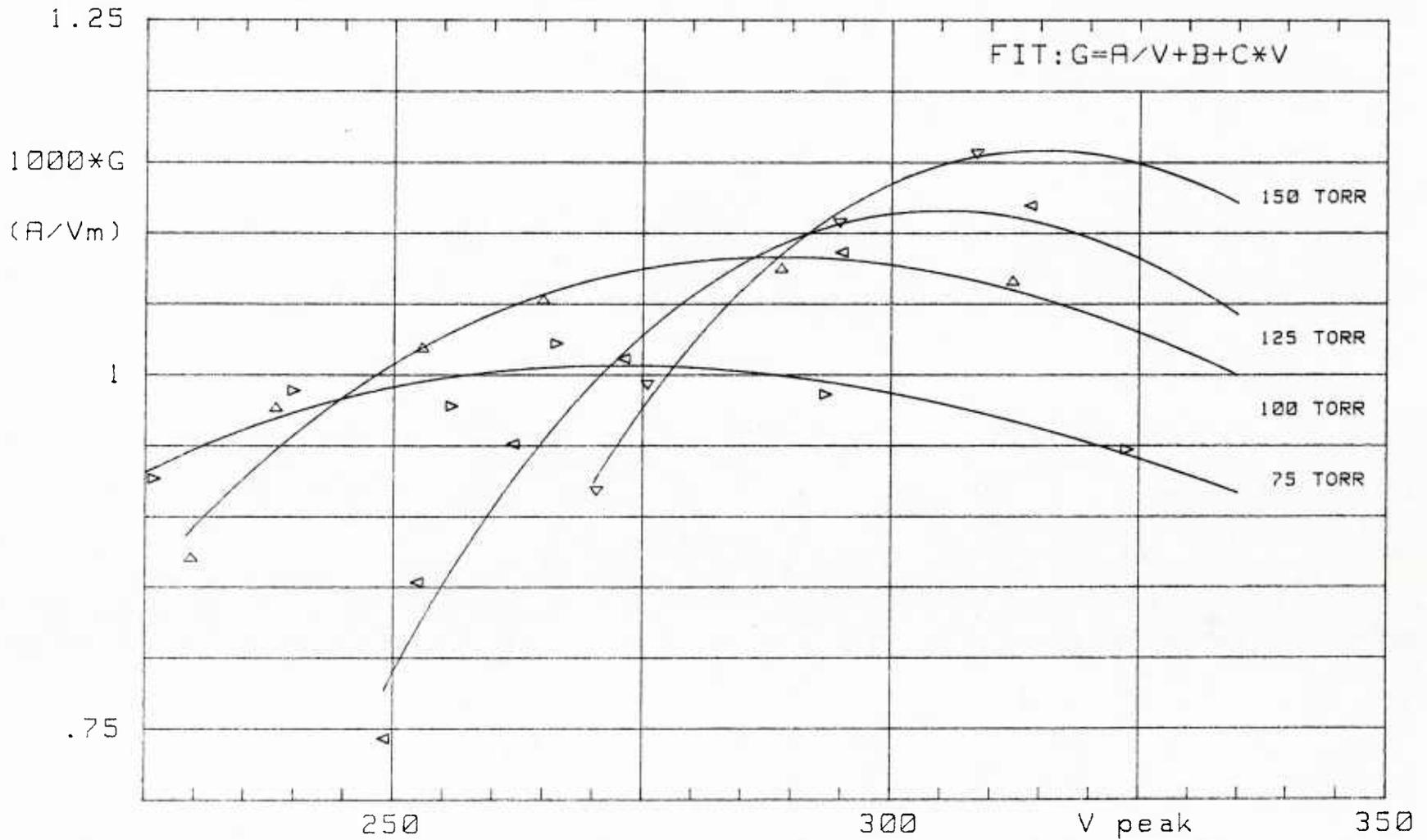
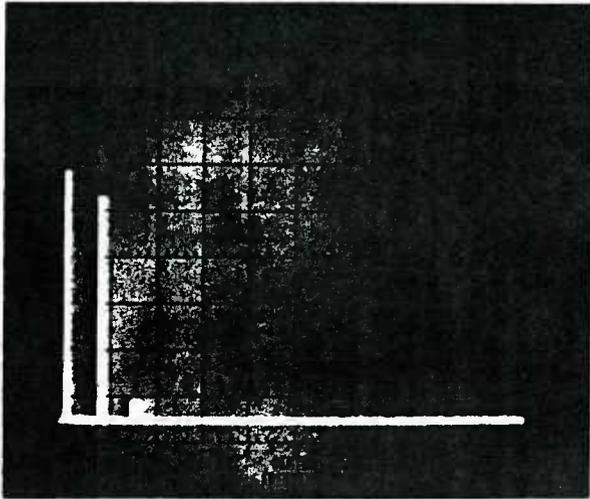
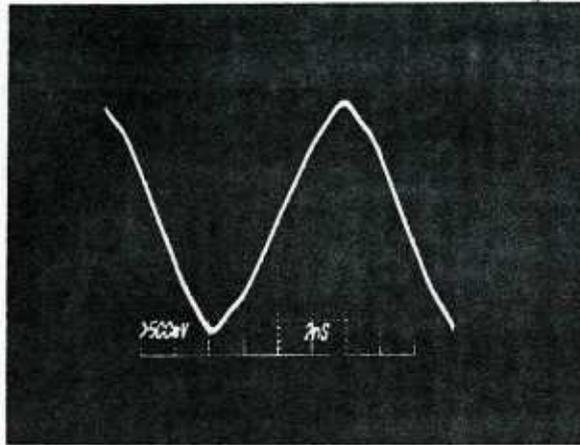

Fig.14, CENTER RF-CONDUCTANCE



70 MHz Transmitter: Output spectrum  
10db per div.



Discharge: Current waveform

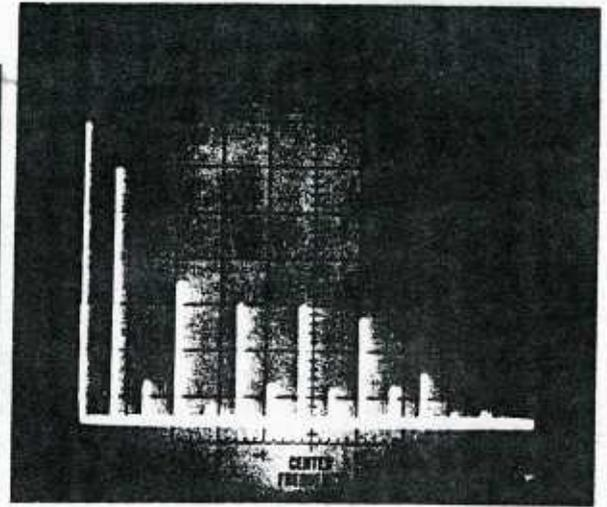

Discharge: Current Spectrum  
10db per div.

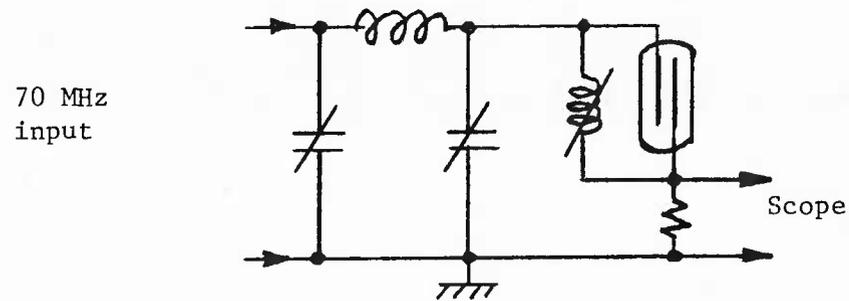

Figure15 DISCHARGE CURRENT WAVEFORM

# APPENDIX

