

AD A 073466

DDC ACCESSION NUMBER

III
LEVEL

DATA SHEET

PHOTOGRAPH

THIS SHEET

1

INVENTORY

AEWES-TR-6-654
DOCUMENT IDENTIFICATION

DISTRIBUTION STATEMENT A
Approved for public release;
Distribution Unlimited

DISTRIBUTION STATEMENT

Accession For	
NTIS GRA&I	<input checked="" type="checkbox"/>
DDC TAB	<input type="checkbox"/>
Unannounced	<input type="checkbox"/>
Justification	
<i>per FL-88 on file</i>	
By _____	
Distribution/_____	
Availability Codes	
Dist	Avail and/or special
<i>A</i>	

DISTRIBUTION STAMP

DDC
RECEIVED
SEP 6 1979
RECEIVED
E

DATE ACCESSIONED

79 09 04 005

DATE RECEIVED IN DDC

PHOTOGRAPH THIS COPY

**INVESTIGATION OF INSTRUMENTS FOR
MEASURING PORE PRESSURES IN CONCRETE**

**LITERATURE REVIEW AND PRELIMINARY
LABORATORY TESTS**



TECHNICAL REPORT NO. 6-654

Report 1

August 1954

**U. S. Army Engineer Waterways Experiment Station
CORPS OF ENGINEERS
Vicksburg, Mississippi**

T
11
6 34

THE CONTENTS OF THIS REPORT ARE NOT TO BE
USED FOR ADVERTISING, PUBLICATION, OR
PROMOTIONAL PURPOSES

PREFACE

The work reported herein constitutes one phase of an investigation authorized by letter from the Office, Chief of Engineers, dated 27 October 1954, subject, "Development of Instruments for Prototype Testing - Item CW 025."

The investigation is being conducted in the Concrete Division, U. S. Army Engineer Waterways Experiment Station, under the general supervision of Messrs. Thomas B. Kennedy and Bryant Mather, and under the immediate supervision of Messrs. E. E. McCoy, Jr., and E. C. Roshore, coauthors of this report.

Directors of the Waterways Experiment Station during the conduct of this work and preparation of this report were Col. Carroll H. Dunn, CE, Col. A. P. Rollins, Jr., CE, Col. Edmund H. Lang, CE, and Ccl. Alex G. Sutton, Jr., CE. Technical Director was Mr. J. B. Tiffany.

CONTENTS

	<u>Page</u>
PREFACE	iii
SUMMARY	vii
PART I: PURPOSE OF INVESTIGATION AND SCOPE OF THIS REPORT	1
PART II: REVIEW OF AVAILABLE DATA AND DESCRIPTION OF INSTRUMENTS . .	2
The Basic Problem	2
Observations of Pore Water and Instrument Installations in Concrete Structures	3
Instruments Available for Measurement of Pore-Water Pressure in Concrete	6
PART III: LABORATORY TESTS AND FIELD INSTALLATION	11
Laboratory Tests	11
Prototype Installation	22
PART IV: SUMMARY OF RESULTS AND CONCLUSIONS	24
REFERENCES	26
TABLES 1-7	

SUMMARY

It is customary to design a gravity dam so that the resultant of all forces acting on it will fall within the middle one-third of the dam. Accurate and economical design, therefore, calls for advance information on the magnitude of the pore pressures that will act in the concrete and in the foundation, and from which the uplift force is to be computed.

From a review of the literature relating to (a) failures of structures, (b) the need for pore-pressure measurements, and (c) experimental techniques, it was concluded that pore-pressure theory alone is not sufficient to assure accurate and economical design; that field measurements should be made, if possible, using several types of instruments that have been found satisfactory for measuring pore pressures; and that laboratory work should be done to improve both techniques and instruments.

To develop information on equipment and techniques for measuring pore pressures in concrete, four types of pressure-measuring instruments were installed in small concrete cylinders and tested at various ages of the concrete under a hydrostatic head of 200 psi. In the tests, all four instruments gave comparable readings. The tests disclosed certain precautions that should be used in installing the meters to ensure accurate readings.

On the basis of these tests, three of the instruments (WES pressure cell, Carlson pressure cell, and piezometer tip) were selected for installation in Hartwell Dam, Savannah River, where results will be observed for several years.

INVESTIGATION OF INSTRUMENTS FOR MEASURING
PORE PRESSURES IN CONCRETE

LITERATURE REVIEW AND PRELIMINARY LABORATORY TESTS

PART I: PURPOSE OF INVESTIGATION AND
SCOPE OF THIS REPORT

1. The comprehensive investigation, one phase of which is reported herein, has as its purpose the development of information on equipment and techniques for making pore-pressure measurements in concrete. Since another part of the investigation involved installation of pore-pressure measuring instruments in Hartwell Dam, Savannah River, during construction, and since information readily available on the selection, installation, and operation of such instruments was very scant, a rather thorough search of the literature on measuring pore pressures in concrete was made. Specific information relating to instruments was found to be scarce; that which was found is summarized in Part II of this report.

2. This report also describes a number of instruments other than those mentioned in the literature which have been or could be used to measure pore pressures in concrete, together with pertinent details concerning their installation and operation. Four instruments were selected for testing in the laboratory, and the tests and results are discussed in Part III. Part IV presents conclusions derived from this phase of the overall investigation.

PART II: REVIEW OF AVAILABLE DATA AND DESCRIPTION
OF INSTRUMENTS

The Basic Problem

3. To preclude development of tensile stresses at the upstream face of a concrete gravity dam, it is customary to design the dam so that the resultant of all forces acting on it will fall within the middle one-third of the dam. The basic problem in using uplift data in concrete dam design computations is determining the value to use for the pore pressure at various points in the foundation and in the dam, by either theoretical computation or experimental measurements; the latter should confirm the former. Ideal fluid theory is applicable to the flow of water through porous media,^{2*} though in reality the flow, which would be microscopic at any given point, would no doubt be very difficult to describe in simple ideal terms. The movement of seepage water underneath an impervious dam resting on a pervious foundation that is isotropic with respect to permeability is depicted by a flow net² consisting of confocal ellipses and hyperbolas.⁷ The pressure varies almost linearly from heel to toe. The assumption of linearity in this particular ideal case permits the obtaining of a value for total pressure which, although not theoretically exact, can be used in design computations. However, conditions seldom approach the ideal in a dam. Since concrete is not impervious, a study of pressure distribution in a dam might be made by means of the flow-net technique, but a review of the literature indicated that actual measurement of pressures in the concrete is desirable. A thorough study of the available literature on the subject of pore pressure and uplift pressures was made for the purposes of this investigation. References containing information on pore-pressure measurement, especially in regard to details of construction and installation of pressure-measuring devices, were very rare.

* Raised numbers refer to similarly numbered items in the list of references at end of text.

Observations of Pore Water and Instrument
Installations in Concrete Structures

Definition and description
of hydrostatic pore pressure

4. Prior to general acceptance of the fact, numerous authors over a long period of time presented information to the effect that concrete is a completely porous and permeable material.^{1,11,17} The advent of the high-pressure test to determine the air content of hardened concrete¹⁶ leaves no doubt that all capillary spaces, as well as other void spaces in concrete, are interconnected. Consequently, since concrete normally is "wet" by water, saturation occurs by capillary action and by flow following Darcy's law approximately.^{4,6} The latter type of activity suggests the presence of differential hydrostatic head, and though flow and saturation may be a slow process, the reservoir head will eventually affect the pressure in the water at any point in the saturated part of a dam, degree depending upon the various conditions of flow. It is this hydrostatic head that any acceptable pore-water pressure-measuring instrument must measure.

Pressure measurements
with piezometer tubes

5. Piezometer tubes have been used for at least 38 years to measure the intensity of the uplift pressure at the foundation of a dam. As reported by Keener,⁵

Beginning in 1925 at American Falls Dam in Idaho systems of vertical wells have been placed across the contacts of the bases of concrete dams with the foundation rock. The number of holes placed to date (1950) is 360 at fifteen dams, an average of 24 holes for each dam.

The pressures so measured thus include the effects of joints or cracks in the foundation rock, rock-concrete bond, and permeability of the foundation material as well as the permeability characteristics of the concrete itself. (In contrast, the piezometer application visualized for purposes of this investigation will measure at a given point in the concrete the pressure due only to concrete permeability.) Piezometer tubes were used to measure uplift pressure at the foundation in Fontana, Hiwassee, and Norris Dams of

the Tennessee Valley Authority,¹⁰ and at some Ontario Hydro-Electric Commission structures,³ as well as numerous United States Bureau of Reclamation (USBR) and Corps of Engineers structures.

6. The intensity of pore pressures within the concrete at various levels above the foundation has been the subject of increasing interest and investigation for approximately 30 years. "Sacks of gravel were embedded in the concrete around the open ends of 1/2-in. diameter pipe, which led to a small vertical shaft where measurements of seepage or uplift could be made..." according to Keener.⁵ Installations of this type were made at Gibson, Owyhee, and Hoover Dams.^{5, p 1218} After 11 years, with no appreciable signs of moisture in any of the units, observations at Gibson Dam were discontinued (1942) except for check readings. Observations at Owyhee Dam since May 1943 had shown no uplift pressure "or even any indication of moisture" by 1950. The 36 uplift units installed at horizontal construction joints within the mass concrete of Hoover Dam "with almost negligible exceptions" showed no uplift pressure or accumulation of moisture (presumably between August 1935 and the time of the report in 1950). This method also yielded no results at Norris Dam.¹⁰

Pressure measurements with piezometer tips

7. An obvious precursor of the present-day piezometer tip was the pore-pressure cell of another type installed in the concrete at Norris Dam.^{10, p 1240} Serafim,¹¹ in his discussion of early attempts to measure pore pressure in concrete, considered the Norris Dam arrangement "a system a little more rational but which still required inflow of much water to be able to measure pressures."

8. According to Riegel,¹⁰ "These cells consisted of porous concrete blocks 12 in. square, each of which was connected with an observation point in a gallery by two small pipes." It would appear that the purpose of the extra tube was to facilitate filling the porous block with water and bleeding off air, as in the present type, so as to reduce the lag in response; however, "During a period of four years no pressures were ever observed on 16 of these 18 cells." Pressure indications given by two cells were believed to have resulted from, in one case, a crack extending to the water surface, which subsequently closed, and in the other, from a crack

extending to water in an expansion joint. As Riegel¹⁰ concluded, "In short, no definite values of pore pressure were obtained in this dam during the four-year period of observation."

Hiwassee and Fontana Dam installations

9. In these two dams three types of instruments--a USBR cell, piezometer tips, and a Carlson-Terzaghi cell, all of which are described subsequently in this report--were used with marked success. The results have been discussed widely^{9,10,12} and, in general, show that pressures increased with time, and that the magnitude of the pressures depended upon the distance of the instrument from the face of the dam.

10. At Hiwassee Dam the pressure measurements were made with only the USBR (Goldbeck, Walker-Pulli) instrument, which is described in paragraph 24. No special trouble was encountered with these meters at Hiwassee Dam.

11. At Fontana Dam, USBR pore-pressure cells of the same kind as those used at Hiwassee were installed together with piezometer tips and a single Carlson-Terzaghi cell. As reported by Riegel,^{10,p 1241} "...the pore pressure cells showed a rather rapid rise and then began to fall--apparently from overstress. The USBR stated that these cells were to be limited to 200 ft of water pressure and this limit seems to be somewhat on the high side." The piezometer tip, however, gave a good record of the pore pressures in Fontana Dam, as did the Carlson-Terzaghi cell, although some trouble was experienced with the piezometer tips, reported by Riegel¹⁰ as follows:

The tips should have been connected with the gages by copper tubing, but, since the installation was made during wartime, the copper tubing could not be obtained and a plastic tubing was substituted. This tubing had to be bent outside the concrete to make satisfactory connection with the gages. After about eighteen months, the plastic tubes began to fail from the combined effects of flexure and pressure. Repairs were finally made on five of the six cells by substituting copper tubing.

12. The normal pool elevation was 1710 ft, and the elevation of the piezometer tips was 1319 ft. Tips were located at the following distances from the dam face: 0.5, 1.0, 2.0, and 3.0 ft. The Carlson-Terzaghi cell was 1.5 ft from the face. Pressures as high as 95 percent

of head were measured by one of the tips near the face of the Carlson cell.

13. In closing, Riegel¹⁰ states:

The history of these measurements indicates some of the difficulties that must be anticipated in making measurements of this kind; and such investigations are much needed....It can be stated, however, that these measurements have demonstrated that pore pressures of material intensity do exist in the region adjacent to the reservoir water and that a gradient is apparent between the reservoir and drainage openings or galleries.

Instruments Available for Measurement of Pore-Water Pressure in Concrete

14. Wells, simple pipes, or tubes generally are not satisfactory for the accurate determination of pore-water pressure in concrete because of the time lag involved in their use. The time lag is caused by the relatively large volumes of seepage water necessary in their operation, and seepage flow rates are too small to provide the volumes of water needed in a reasonable period of time. Time lag can become very excessive when instruments of these types are used for measurements in concrete of low permeability. To prevent this lag in the reading of the instruments, tubes used to transmit water pressure from the point of measurement to external instruments must first be filled with water. Some instruments which have been used or suggested for use in concrete are described in the following paragraphs.

Piezometer tubes

15. Small glass tubes, which can rightly be called piezometer tubes, as well as metal pipes as large as 1/2 in. in diameter are suitable for measuring pore pressure in studies of laboratory models of structures when lag is unimportant. Larger pipes, 1-1/2 in. in diameter, are usually placed in dams so that a tape can be lowered into the pipe to determine the water level if necessary, or pressure gages can be attached if the inspection gallery is below the level of the rising water.

Piezometer tip

16. The piezometer tip, illustrated in fig. 1, is perhaps the simplest in operation of all the instruments described herein. The tip consists of a plastic or metal cylindrical cell with a porous plug at one end

for the admission of water, and entrance and exit tubes at the other end. The exit tube connects externally to a Bourdon pressure gage which has a bleeder valve on the end of the Bourdon tube. The entrance tube is provided

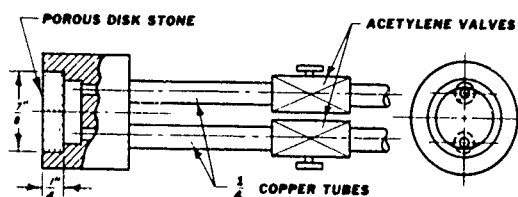

Fig. 1. Piezometer tip

with a stopcock through which the system is filled with water. After installation of the tip has been completed, water is flushed through the system, including the Bourdon gage, so that air bubbles which cause sluggish response will not remain in the system. Piezometer tips are generally very accurate if the tubing does not leak. The head of water between tip and gage must be added to all measurements, and pressures less than this head cannot be measured effectively.

Walker-Pulli cell

17. This instrument, covered by U. S. Patent No. 2,645,128, is il-

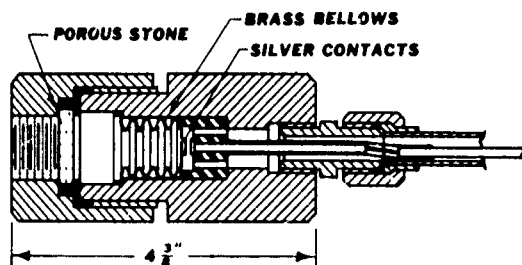

Fig. 2. Walker-Pulli cell

lustrated in fig. 2. It is similar in appearance to the piezometer tip but is essentially different in operation. Water passes through the porous plug and actuates a metal bellows, the movement of which causes an electrical contact to be made. The contact points are connected by a wire passing

through a watertight tube to a signal light, the tube itself serving as one conductor. Air or some other gas under pressure, the pressure of which is indicated on a Bourdon gage, is connected to the cell through the tube and produces a back pressure on the bellows. When the signal light goes off, the pressure indicated by the gage is approximately the same as the water pressure in the cell. To obtain a more accurate measurement, the pressure is decreased and increased several times and the differential between "on" and "off" readings noted and considered. In tests at the U. S. Army Engineer Waterways Experiment Station (WES), described later, apparently the variability of required contact pressure introduced an error too large to be tolerated in measurements of the relatively small pressures of interest in this study.

Carlson-Terzaghi cell

18. Water enters the Carlson-Terzaghi cell (fig. 3) through a porous

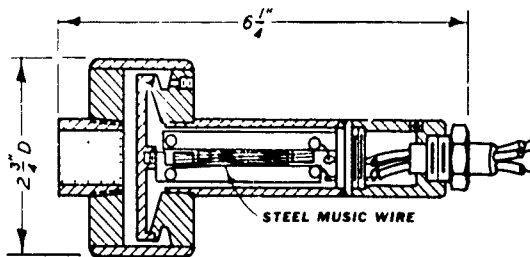

Fig. 3. Carlson-Terzaghi cell

plug. The pressure of the water acts on a steel diaphragm, the deflection of which is measured by an unbonded strain meter. A three-conductor cable connects the instrument to an external test bridge. Temperature measurements also are part of the routine procedure

for measurements with this instrument. Tests at WES with this instrument have been satisfactory (see Part III).

WES hydrostatic pressure cell

19. In this instrument (covered by U. S. Patent No. 2,360,886), the strain induced in a metal diaphragm by water pressure is measured by means of bonded resistance-wire strain gages. This cell (shown in fig. 4) gave satisfactory results when tested at WES. Prior to the tests at WES, the instrument had been used in earth masses (e.g. at Dorena Dam) but not in concrete.

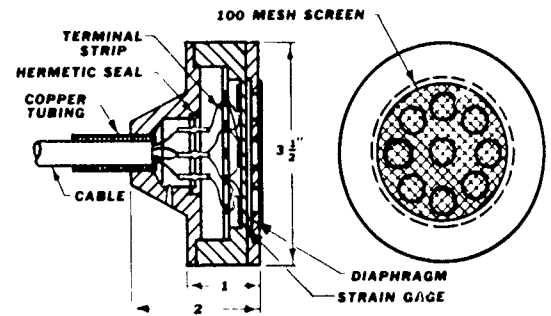

Fig. 4. WES hydrostatic pressure cell

Readings are taken with a standard SR-4 strain indicator. A four-conductor cable connects the full-bridge SR-4 circuit to the external indicator. The WES cell, as well as the Carlson-Terzaghi cell, can be installed in concrete with very little difficulty, since standard conductor cables are used. However, splices must be waterproof. Vulcanization of splices is recommended.

WES force balance cell

20. Operating somewhat on the principle of the Walker-Pulli cell, this instrument depends upon balancing by the application of internal pneumatic pressure on a diaphragm the external fluid pressure on the other side, balance being indicated by electrical signal. Though it has not been tested in concrete, there appears to be no reason why the instrument should not operate properly in this medium since the similar Walker-Pulli

instrument gave satisfactory results except as previously noted (paragraph 17). The WES force balance cell has the advantages of small volume change, low cost, and independence of the cell with regard to the elastic properties of the material of which the diaphragm is made.

WES unbonded cell

21. In this instrument deflections of a flat diaphragm are measured by means of unbonded resistance-wire strain gages. It is a new design, having the advantages of small volume change and small size, being only 1 in. in diameter and 2-1/2 in. long. This cell is a modification of a cell produced by Consolidated Electrodynamics Company, Pasadena, Calif.

WES differential transformer

22. WES has another new design in which the deflection of a bellows is measured by a linear variable differential transformer. This instrument has not been tested in concrete.

Los Angeles cell

23. The U. S. Army Engineer District, Los Angeles, has developed a pore-water pressure measuring device which departs appreciably from others in design. It consists of a mercury-in-glass transducer inclosed in a metal housing. The variable resistance of the transducer depends on the length of mercury contact with a colloidal graphite-coated glass capillary. The transducer is similar in appearance to a mercury-in-glass thermometer except that the bulb is larger and flattened endwise. This instrument, developed in 1940 and materially improved in 1950, is reputed to have given better results than were obtained with several other types of instruments tested in soils by the Los Angeles District.¹³

USBR type I cell

24. The operating principle of this instrument is the same as or similar to that of the Walker-Pulli instrument described previously. Hydrostatic pressure on one side of a diaphragm and back pressure of air from an external source control the movement of the diaphragm, which, by means of an electrical contact, actuates an external signal light or buzzer. The back pressure is measured by means of a Bourdon tube gage. A portable air supply can be used. As stated earlier, instruments of this type were installed, during construction, in Fontana and Hiwassee

Dams (see paragraphs 9-13). They are not recommended for pressures in excess of about 75 psi, and are not regarded as being reliable for long periods at pressures above 50 psi. Also, excessive care is required in reading them.

USBR type II cell

25. This instrument is the same as the USBR type I cell, with the addition of a flushing or purging tube. As far as is known, this instrument has not been used in concrete dams.

Statham hydrostatic pressure cell

26. The deflection of a diaphragm in this cell is measured by an unbonded resistance-wire strain gage. There is no record of use of this instrument in concrete, but it has been used to measure hydrostatic pressures in soil at Dorena Dam, U. S. Army Engineer District, Portland, CE.

Telemac hydrostatic pressure cell

27. Deflections due to pressure on a flat diaphragm change the vibrating frequency of a taut wire, and the frequency is measured by an acoustical null method. This instrument has been used in Europe in concrete dams and tunnels. Data on its use can be obtained from Telemac, Paris, France. A laboratory examination of a similar instrument is described by Muhs and Campbell-Allen.⁸

PART III: LABORATORY TESTS AND FIELD INSTALLATION

Laboratory TestsPurpose and scope

28. In order to select instruments for comparative testing in a dam (tests to be conducted at a later date, see paragraph 58), representative types of instruments were tested in the laboratory at WES. The specific purposes of these tests were to determine calibration and operational characteristics prior to installation of some or all of the instruments in a dam. The instruments were first calibrated for accuracy of reading in water. Then three series of tests were made with the instruments installed at the midplane of concrete cylinders of a type used in permeability tests. Variables in these tests were: cement content and age of concrete; position of porous face of instrument (down, up, and vertical); pressure cell chambers empty, or filled with petroleum jelly to prevent time lag in pressure reading; and pressures of (a) 200 psi at the top and zero at the bottom, or (b) 200 psi at both top and bottom of test cylinder.

Instruments tested

29. One each of the following four pore-pressure measuring instruments, together with necessary gages and test sets, were procured for the tests.

<u>Pore-Pressure Instrument</u>	<u>Test Set or Gage</u>
Piezometer tip	Heise pressure gage
Walker-Pulli pressure cell	Heise pressure gage
Carlson pressure cell	Carlson test set
WES hydrostatic pressure cell	SR-4 strain indicator

These instruments are illustrated in figs. 1-4 (pages 7 and 8).

Calibration of instruments

30. The four instruments were calibrated by use of permeability test equipment;¹⁵ known hydrostatic loads were applied to each instrument in nominal 20-psi increments up to approximately 200 psi, and the indicated pressures were recorded. These calibration data are given in table 1. The deviations of the pressures indicated by the four instruments from the nominal applied pressure were determined and are listed in table 2 and plotted

in fig. 5. The average deviations disregarding signs were:

Piezometer tip	0.02 psi	WES cell	1.55 psi
Walker-Pulli cell	0.79 psi	Carlson cell	1.26 psi

The calibration tests were for comparative purposes only, and no corrections were applied to the indicated pressure data collected during the conduct of the subsequent test series.

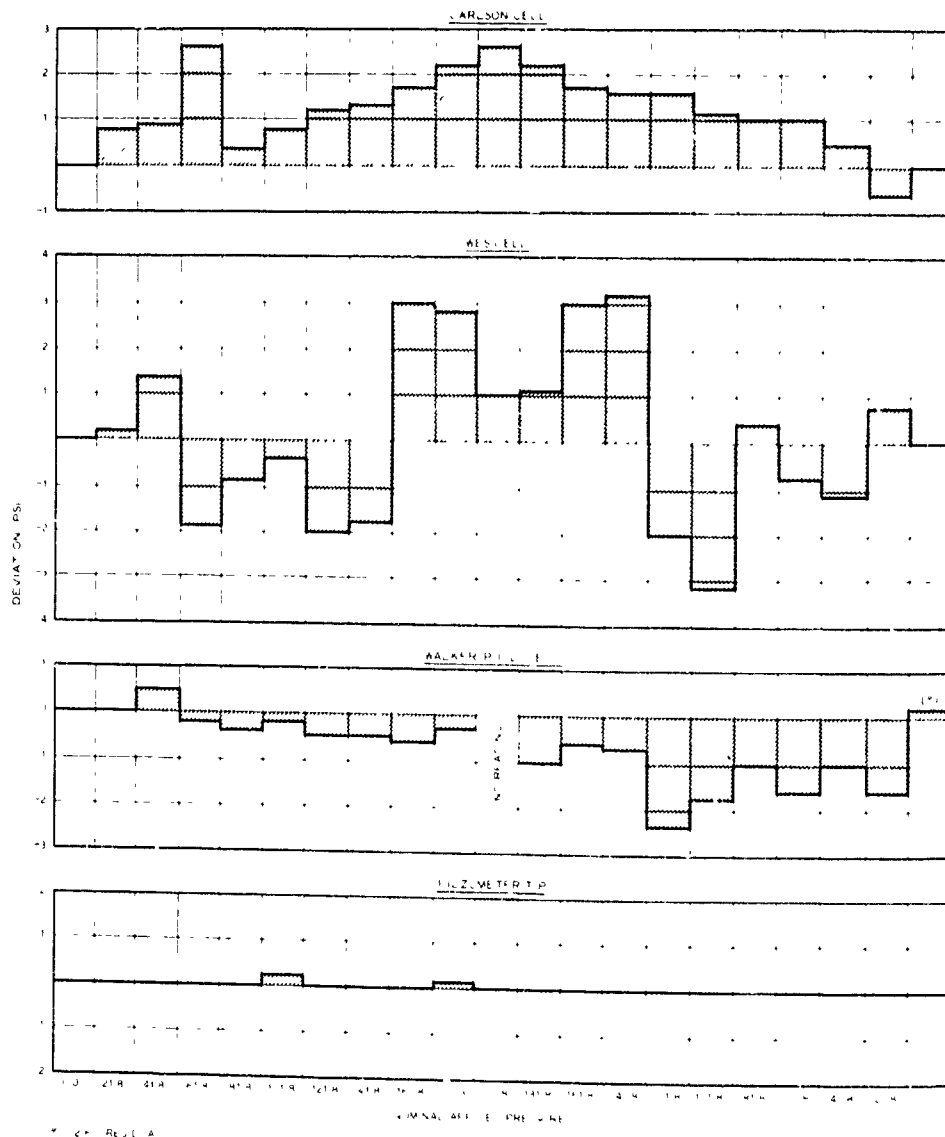

Fig. 5. Deviation of instrument indications from nominal applied pressure

The various pressure cells had inherent precision limits. The least scale division for a reading of the Carlson cell corresponded to 0.8 psi, and

that for the WES cell 0.7 psi. The precision of the piezometer tip was approximately that of the pressure gage to which it was connected, or ± 0.25 psi. The same was true for the Walker-Pulli gage, though some difficulty was experienced with electrical contacts.

First test series (instrument porous face down)

31. Test specimens. Four permeability specimens (14-1/2 in. in diameter by 15 in. high)¹⁴ were made using 3-in. maximum size crushed limestone. The water-cement ratio of the concrete was 0.5 by weight; the cement factor was 4.5 bags per cu yd. One pore-pressure instrument was installed in each specimen before the concrete hardened; the instrument was placed with its porous face down at the horizontal midplane of the specimen. The face of the porous plug of each instrument was covered with a fine-woven cloth. Sheet-metal forms without tops were used. The lead wire and piezometer tubing passed out through a snug-fit hole at the horizontal midplane. The specimens were allowed to remain in the vertical position during hardening, and were cured in fog until time of test. No covers were placed on the forms during the curing period.

32. When the specimens reached 12 days age, the forms were taken off and laitance was removed from the top surface and glaze from the bottom surface by wire brush and sandblasting. The specimens were prepared for testing in the same manner¹⁴ as are other permeability specimens of the same size, except that a vacuum was not used to evacuate air from the specimen.

33. Tests of 14-day-old specimens. At 14 days age, the specimens were covered with water in the permeability test apparatus and an air pressure of 200 psi (nominal) was applied. Pressure and permeability readings were then taken approximately daily for a period of 16 days.

34. After 16 days of testing, the outlet valve of the permeability test apparatus was closed and the instruments were observed simultaneously to determine the effect of the valve closure. The bypass valve was then opened to apply pressure of 200 psi on both top and bottom surfaces of the test specimens. Readings were taken for approximately one week; the pressure was then released, but the

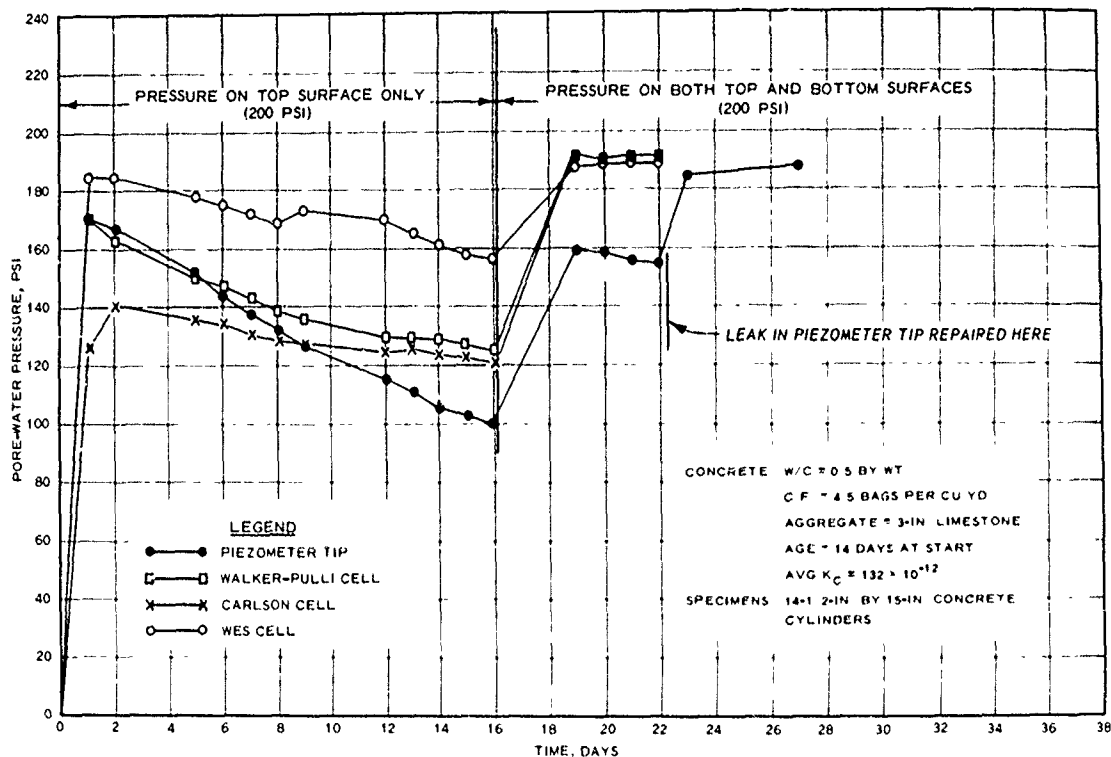

Fig. 6. Pressures measured in first test series with porous face of instruments down; concrete cylinders 14 days old at start of test

specimens remained in the apparatus at atmospheric pressure until they were 97 days old (discussed in paragraph 36).

35. Fig. 6 and table 3 show the pressure readings at all four instruments during these tests. Fig. 6 indicates that pressures considerably higher than 100 psi were measured during the first 16 days of the test, reaching a maximum on the first or second day, and then diminishing. During the last week of the tests a leak in a connection of the tube leading from the piezometer tip to the pressure gage was detected. The leak, though so small that it was not immediately noticed, allowed passage of sufficient water to cause a reduction in the indicated pressure. The importance of a leakproof system for piezometer measurements is well illustrated by this experience. The leak was repaired on the twenty-second day of the test. Thereafter, the piezometer-tip pressure increased to a value which was approximately the same as the pressures indicated by the other three instruments. It is considered that there was very good agreement between the four recorded pressures at the conclusion of these tests.

36. Tests of 97-day-old specimens. At 97 days age, the specimens

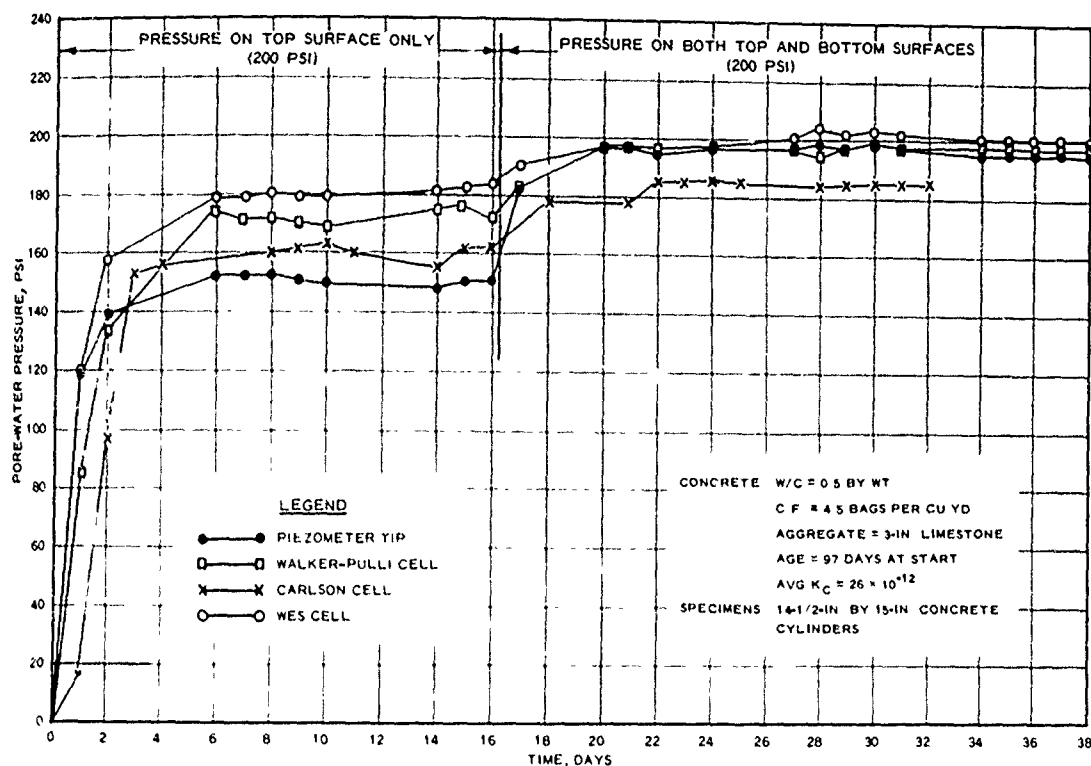

Fig. 7. Pressures measured in first test series with porous face of instruments down; concrete cylinders 97 days old at start of test

were retested in the same manner as at 14 days age except that last portion of test was continued for about three weeks. Fig. 7 and table 4 show the pressure increase obtained in the tests of the 97-day-old specimens. It appears that there was satisfactory agreement between the pressures read on three of the four instruments at the conclusion of the test, with the Carlson-cell pressure being about 11 to 16 psi lower than the others. However, absence of petroleum jelly, which is usually placed in the pressure chamber of the Carlson cell and the WES cell to transmit pressure instantly when water penetrates the porous face, may have prevented the obtaining of valid zero readings between tests. It was therefore decided to repeat the tests later with the pressure chambers of these cells filled with petroleum jelly. Apparently lag in readings can be appreciable in concrete of very low permeability without this precaution.

37. Permeability constants. The permeability constants obtained in the 14- and 97-day tests are given in the tabulation on the following page.

Permeability, $K_c \times 10^{12}$, cfs/ft² (ft head per ft)

Specimen Containing	Permeability, $K_c \times 10^{12}$, cfs/ft ² (ft head per ft)	
	14 days Age	97 days Age
Walker-Pulli cell	83	20
Piezometer tip	241	38
Carlson cell	93	27
WES cell	<u>113</u>	<u>19</u>
	Avg 132	Avg 26

Second test series (instrument porous face up)

38. For this test series, two of the cylindrical concrete specimens fabricated for the first series of tests (+those containing the WES cell and piezometer tip) were inverted in the permeability test containers, but otherwise tested (at 174 days age) as in the first series of tests with pressure applied to one face only. This inversion caused the porous face of the instruments to be up at the horizontal midplane of the specimen. Permeability and pore-pressure readings were taken for a period of approximately 60 days. Fig. 8 and table 5 give these pressure readings.

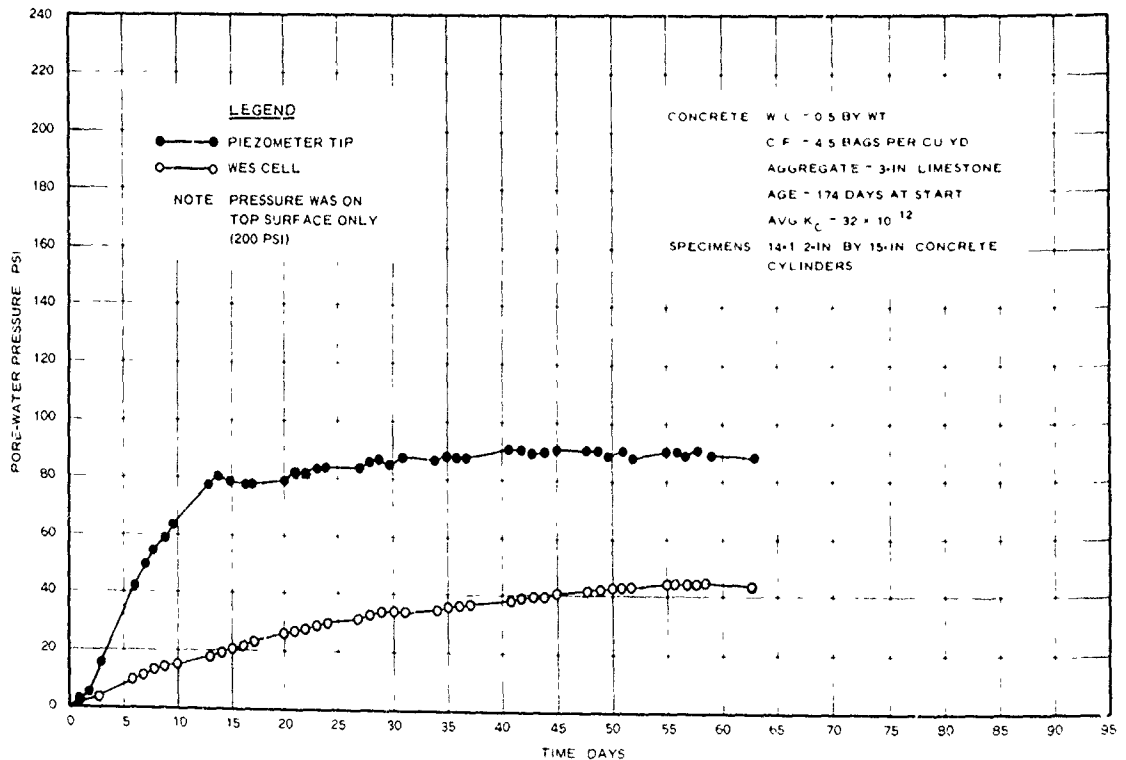

Fig. 8. Pressures measured in second test series with porous face of instruments up; concrete cylinders 174 days old at start of test

39. The pressure increases indicated by the two instruments differed sharply, with the final indicated pressures being: WES cell, 44.0 psi; piezometer tip, 88.5 psi.

40. The permeability constants obtained in this series of tests were:

<u>Specimen Containing</u>	<u>Permeability, $K_c \times 10^{12}$, cfs/ft² (ft head per ft)</u> <u>174 days Age (Inverted in Containers)</u>
Piezometer tip	27
WES cell	<u>37</u>
Avg	32

Recovery of instruments

41. At the conclusion of the second series of tests, all pore-pressure instruments were carefully removed from the encasing concrete cylinders, using a hammer and chisel to break pieces of concrete out away from the pore-pressure cells. After removal, all instruments were found to be in good working condition.

Third test series (instrument porous face vertical)

42. Test specimens. Three permeability specimens (14-1/2 in. in diameter by 15 in. high) were fabricated using a concrete mixture containing crushed limestone graded up to 3 in., having a water-cement ratio of 0.8 by weight, and a cement factor of 3 bags per cu yd. One of the recovered pore-pressure instruments, except the Walker-Pulli cell, was installed in each specimen during fabrication; the instrument was placed so that the porous face was in a vertical position at the horizontal midplane of the specimen. Wires were brought out through the packing glands so that pressure could be applied either to top or to both top and bottom simultaneously. The face of the porous plug of each instrument was covered with a fine-woven cloth. The Walker-Pulli cell was not tested because poor electrical contacts made readings difficult to obtain. The pressure chambers of the WES and Carlson cells were filled with petroleum jelly prior to installation in the concrete. The specimens, in sheet-metal forms without tops, were allowed to remain in the vertical position during hardening and were cured in fog until time of test. No covers were placed on the forms

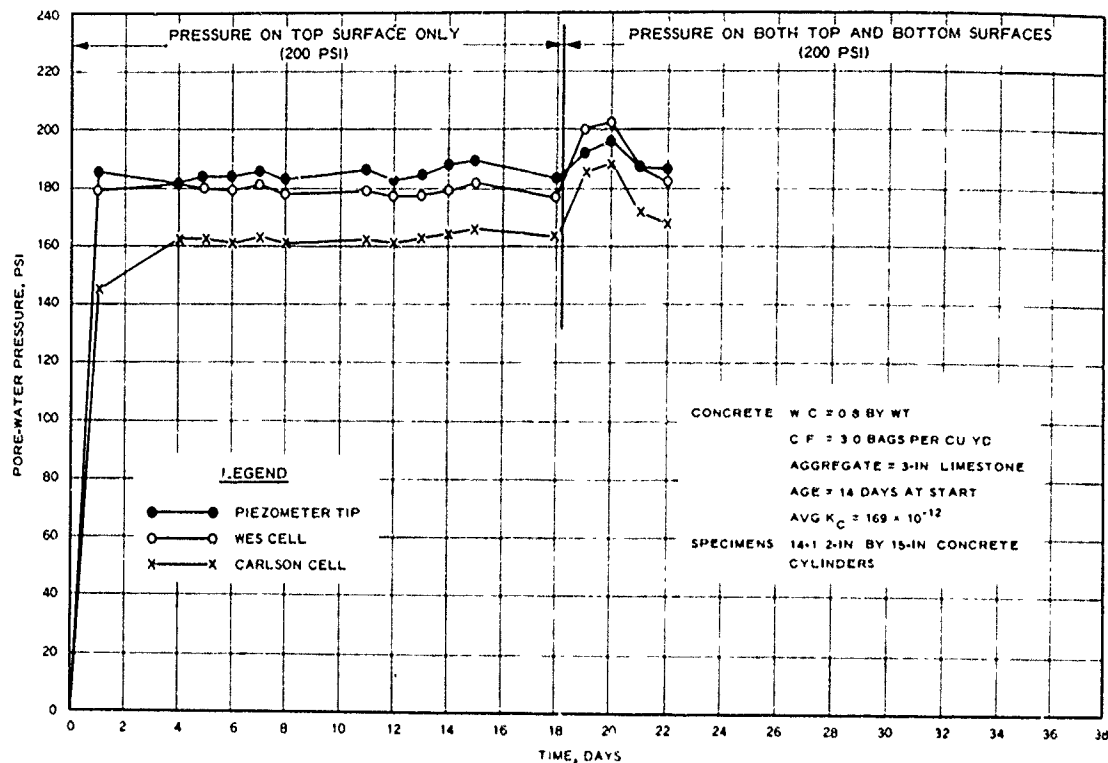

Fig. 9. Pressures measured in third test series with porous face of instrument vertical; concrete cylinders 14 days old at start of test

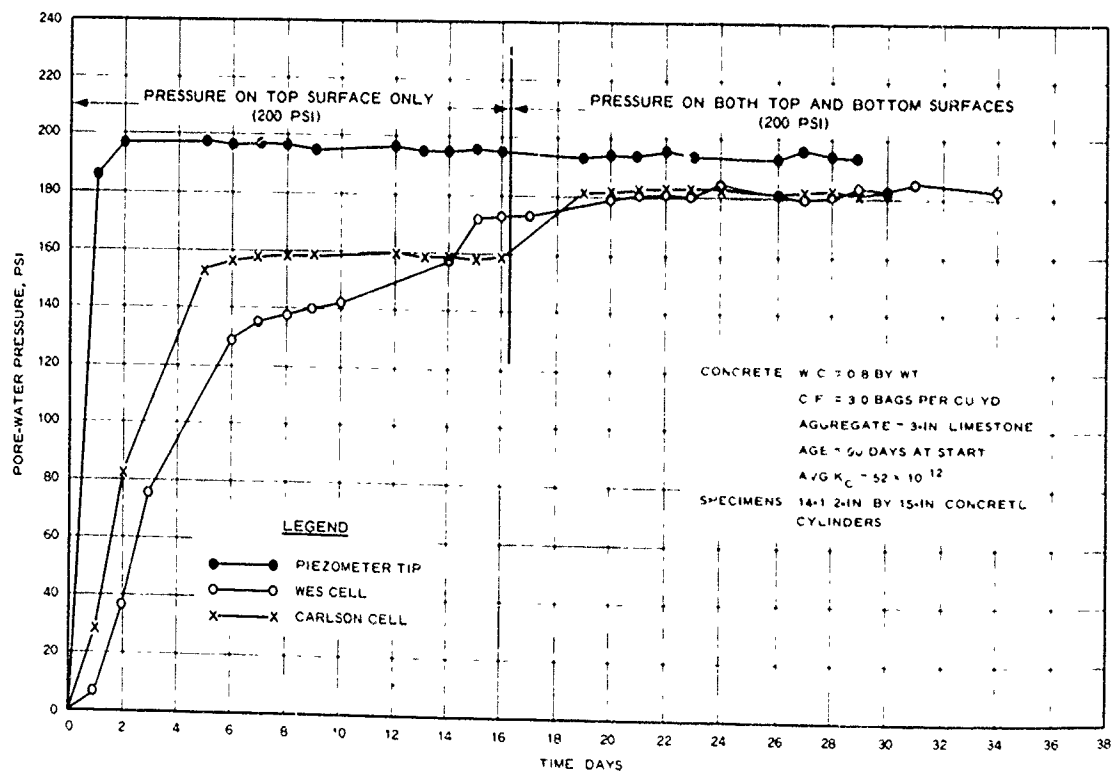

Fig. 10. Pressures measured in third test series; concrete cylinders 90 days old at start of test

during the curing period. The three specimens were tested at 14 and 90 days age following the same testing sequences and applied pressures as in the first series of tests.

43. Tests. In the 14-day tests, permeability and pressure readings were taken as before. Pressures measured are shown in fig. 9 and table 6.

44. In the 90-day tests, the same readings taken in the 14-day tests were obtained. Data obtained are given in fig. 10 and table 7.

45. Results. Table 6 shows that at the conclusion of the 14-day tests there was a spread of 17.5 psi in the pressures indicated on the three instruments under test. Table 7 shows that there was a spread of 10.5 psi in the pressures read on the three instruments at the conclusion of the 90-day tests.

46. The permeability constants obtained in these 14- and 90-day tests were:

<u>Specimen Containing</u>	<u>Permeability, $K_c \times 10^{12}$, cfs/ft² (ft head per ft)</u>	
	<u>14 days Age</u>	<u>90 days Age</u>
Piezometer tip	216	53
Carlson cell	109	52
WES cell	<u>182</u>	<u>51</u>
	Avg 169	Avg 52

Discussion

47. One consideration in the design of a dam is the allowance to be made for uplift due to pore pressure. The intensity of pore pressure depends upon the permeability of the concrete, the depth of the reservoir, and the length of time the reservoir remains filled. Permeability is influenced by cement content, among other things, and since the tendency in dam construction is toward leaner mass concrete, with resulting increasing pore pressures and uplift, the actual determination of pore pressures becomes more important and desirable.

48. There seems to be considerable difference of opinion as to the rapidity with which pore pressures develop, since permeability of concrete decreases both with age and saturation. It has been estimated that it would take 400 years for water under 400 ft of head to penetrate through 200 ft of good, air-entrained concrete that contained even as little as 2 bags of cement per cubic yard.

49. Instruments to measure pore pressure should be accurate, dependable, rugged, and long-lived. The investigation just described was not intended to develop new instruments, but to select and test promising instruments in the laboratory as a basis for selection of instruments for a test installation in the field.

50. In the first test series (cement factor 4.5 bags per cu yd, all four instruments placed horizontally and face down), observations of the specimens under 200-psi hydrostatic pressure were begun when they were 14 days old. As shown in fig. 6, pressure built up very rapidly at the positions of most of the pressure cells, possibly because of channeling, either along the lead wires or through relatively more porous channels through the concrete. It appears that these conditions were transient to a very considerable extent. A small leak was discovered in one of the pipes of the piezometer system, which may have had an effect on pressure changes in this system.

51. All instruments registered peak pressures at one to two days (see fig. 6). Pressures declined gradually from then until 16 days when the bottoms of the chambers were closed and pressure was applied top and bottom. At the peak, all instruments registered considerably more pressure than the 100 psi expected at the middepth of the specimen. The excess pressure above that anticipated probably resulted from the effect of higher permeability in the upper half of the specimen.

52. The point in time when pressure was applied to the bottom is evident by the upturn in the curves at 16 days (fig. 6). The point where the leak was repaired in the piezometer system is apparent at 22 days. Pressures indicated on the piezometer rose thereafter, and at 27 days had risen to 188.5 psi; the highest pressure measured on the other instruments (for which tests ceased 5 days earlier) was 191.0 psi. The range in maximum pressures thus was only 2.5 psi; this is very good agreement between the instruments.

53. With pressure only on the top surface, the gradual diminution of pressure with time is believed to be a result of nonuniform time-variation of the permeability at various depths in the specimen. This phenomenon was not noticeable in the results of tests of the same specimens at a later age (see fig. 7).

54. The Walker-Pulli cell gave some indication of faulty or dirty electrical contacts in the circuit of the signal light. In time, corrosion might impair operation of the signal light. It was often necessary to take several readings with this instrument, starting alternately with high and low back pressure, in order to get a satisfactory reading. When the specimens had been tested for 22 days (27 for the piezometer-tip specimen), pressure was shut off and allowed to subside in all specimens for 60 days, at which time residual pressure still remained in some instruments.

55. When the specimens were retested at the age of 97 days, pressures generally rose to equilibrium, as shown in fig. 7, without appreciable reduction in pressure thereafter as had been the case in the 14-day tests. After 16 days, when pressure was applied to the bottom of the specimens also, the pressures rose from an average equilibrium value of 167 psi to a new equilibrium 6 days later of 192 psi, with a very slight increase in most pressures read thereafter. The range in pressures after 22 days of test was 11.5 psi, residual zero pressure possibly accounting for some of the error. Better agreement in permeability values was obtained on the 97-day-old than on the 14-day-old specimens, as shown in the tabulation in paragraph 37, though equilibrium pressure values indicate that a substantial difference in permeability prevailed between the upper and lower halves of the specimens.

56. In the second series of tests, the first-series specimens containing the piezometer tip and WES cell were again tested, but in an inverted position so that the porous faces of the instruments were up. These tests were begun when the specimens were 174 days old. As shown in fig. 8, neither instrument indicated appreciable pressure for two days. After two days, pressure built up in the piezometer tip, leveling off at about 90 psi after six weeks. Pressure in the WES cell started building up after two days and climbed slowly for about eight weeks, leveling off at about 45 psi. The fact that neither instrument indicated the expected 100-psi pressure showed possible relief of pressure due to (a) channeling along the tubing and leads, (b) different permeability of the concrete above and below the instruments, or (c) leakage in the piezometer system; the latter is not believed likely because the only detectable leak had been repaired. Over a period of years, in permeability tests for other programs, results of

tests of a large number of specimens of a different size (6- by 12-in. cylinders) sawed laterally in half showed generally that upper halves are more permeable than lower halves. The results of the second test series were generally consistent with the pressure values observed in the first series, both with respect to possible channel flow along the leads and the difference in permeability between the upper and lower halves of the specimens. Thus the effect, if any, of orientation of the cell face was not apparent.

57. In the third test series (cement factor 3 bags per cu yd, three instruments placed vertically, and chambers of WES and Carlson cells filled to reduce time lag in pressure readings), pressure rose sharply in the 14-day-age tests for one day, as shown in fig. 9, then rose gradually to an equilibrium value of approximately 170 psi, again unexpectedly high. In the test of the 90-day-old specimens, fig. 10, the piezometer responded rapidly, but pressure rise in the other cells was more gradual than in the tests of the 14-day-old specimens; the piezometer pressure of 197 psi indicated severe channeling, especially since this pressure did not increase after pressure was applied to top and bottom of the specimen. With pressure on top and bottom, the range in pressures read on all instruments after 29 days was 10.5 psi.

Prototype Installation

58. The WES cell, the piezometer tip, and the Carlson cell were selected for installation in Hartwell Dam on the Savannah River (see fig. 11).

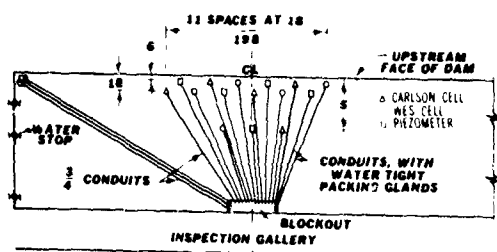

Fig. 11. Pore-pressure meter layout (plan), Hartwell Dam

The Walker-Pulli meter was not selected because of the difficulty that had been experienced with the electrical contacts in the laboratory tests. The piezometer tip provides a mechanical system in parallel with the two electrical cells. During the summer of 1959, six cells of each type (18 in all) were installed at elevation 483 near the bottom of the reservoir, and six more of each type at elevation 558. Maximum head over the lower instruments (which have a range of 100 psi) is expected to be

about 182 ft (79 psi), and over the upper instruments (which have a range of 50 psi) 107 ft (46 psi) when the water rises in the reservoir. It is expected that the installation will remain operative for many years.

PART IV: SUMMARY OF RESULTS AND CONCLUSIONS

59. A review of the pertinent literature revealed that, while the theory of fluid pressure and flow should be thoroughly understood by persons responsible for pore-pressure measurements and the analysis of the data, the application of theory alone is not sufficient to provide completely accurate information on the effective pore pressure at various points in a dam.

60. The laboratory tests reported herein were designed to determine the relative worth of several types of instruments and their suitability for installation in a prototype structure. The instruments tested were: the WES pressure cell, the Carlson-Terzaghi pressure cell, the Walker-Pulli pressure cell, and the piezometer tip. The first two have basically electrical circuits and the third depends upon a back pressure to actuate an electrical indicator; the fourth simply depends on the action of the water pressure exerted through tubes to register on the indicator. All of these instruments had been used previously in prototype structures with at least qualitative success. They were found satisfactory for measurement of pore-water pressures in concrete in these tests. However, it is cautioned that in using instruments of the Walker-Pulli type, care should be taken to ensure that the instrument has clean, noncorroding contacts and that the highest pressures to be measured will not damage the bellows.

61. The data obtained in the laboratory tests indicated rather clearly the difficulties that might be encountered in field installations because of channeling along the leads from the instruments. If the small chambers in front of the diaphragms of the electrical instruments are filled with petroleum jelly and if the piezometers are properly flushed and primed on installation, they will all immediately register the pressure wave due to permeating water; however, if there is channeling along the leads, water will be conducted away from the meter and the full magnitude of the pressure in the pores of the concrete in the neighborhood of the meter will not be registered.

62. In the use of the piezometer tip it is essential that tubes, valves, and connections be leakproof. The amount of water that passes through the concrete and into the piezometer tip is so small that any loss

of water in the pressure system might greatly affect the pressure indication.

63. The average of the pressures indicated by three instruments (WES cell, Carlson cell, and piezometer tip) was 9 psi higher after 14 days of test with faces of the instruments vertical than it was with the faces horizontal (first series at 97 days age and third series at 90 days age). A larger difference in the same direction may be noted for results of tests beginning at 14 days age (figs. 6 and 9). With faces vertical, the porous plug of the instrument was partly above the center of the specimen. The instruments apparently would thus tend to measure pressures representative of the uppermost levels contacted by the plugs. It can hardly be concluded, however, because of the test variables mentioned throughout the report, that the differences in the average pressures noted were caused by instrument orientation.

64. In view of the large differences in permeability values for different parts of the test specimens which were revealed in the tests, in practice some consideration might be given to proper instrument location within a lift of concrete in a gravity structure. Although the hydrostatic pore pressure gradient in a dam is normal to the variations in permeability which might exist within a single lift, it would seem logical to expect higher pore pressures to exist in the top portion of a lift than near the bottom.

REFERENCES

1. Ballester, R. E., discussion of "The significance of pore pressure in hydraulic structures." Transactions, American Society of Civil Engineers, vol 114 (1949), pp 243-245.
2. Daugherty, R. L., and Ingersoll, A. C., Fluid Mechanics, with Engineering Applications, 5th ed. McGraw-Hill Book Co., Inc., New York, N. Y., 1954, pp 45, 65, 66.
3. Gibson, W. L., "Some experiences in investigating stresses and forces in massive structures." The Canadian Mining and Metallurgical Bulletin, vol 49, No. 528 (April 1956), pp 241-253.
4. Harza, L. F., "The significance of pore pressure in hydraulic structures." Transactions, American Society of Civil Engineers, vol 114 (1949), pp 193-214.
5. Keener, K. B., "Uplift pressures in concrete dams." Transactions, American Society of Civil Engineers, vol 116 (1951), pp 1218-1237.
6. Meyer, A. A., discussion of "The significance of pore pressure in hydraulic structures." Transactions, American Society of Civil Engineers, vol 114 (1949), pp 218-222.
7. Muckleston, H. B., discussion of "The action of water under dams." Transactions, American Society of Civil Engineers, vol 80 (1916), pp 453-454.
8. Muhs, H., and Campbell-Allen, D., "A laboratory examination of an electrical pore pressure gauge for use in earth dams." Journal of the Institution of Engineers, Australia, vol 27, No. 9 (September 1955), pp 241-245.
9. Riegel, R. M., "Structural features of hydraulic structures." Transactions, American Society of Civil Engineers, vol 111 (1946), pp 1160-1174.
10. _____, discussion of "Uplift pressures in concrete dams." Transactions, American Society of Civil Engineers, vol 116 (1951), pp 1238-1242.
11. Serafim, J. L., A Subpressao nas Barragens (Uplift Pressures in Dams). Report No. 35, Ministry of Public Works, National Laboratory of Civil Engineering, Lisbon, 1954. Note: Bibliography lists 204 references.
12. Tennessee Valley Authority, The Fontana Project. Technical Report No. 12, Government Printing Office, Washington, D. C., 1950.
13. U. S. Army Engineer District, Los Angeles, CE, Test of Los Angeles Type Pore Pressure Gage. Final Report, Control Symbol ENGKW-68, July 1959.
14. U. S. Army Engineer Waterways Experiment Station, CE, "Method of test for water permeability of concrete." Method CRD-C 48-55, in Handbook for Concrete and Cement, Vicksburg, Miss. (August 1949).

15. U. S. Army Engineer Waterways Experiment Station, CE, Permeability and Triaxial Tests of Lean Mass Concrete. Technical Memorandum No. 6-380, Vicksburg, Miss., March 1954, revised July 1955.
16. _____, High-Pressure Test for Determining Air Content of Hardened Concrete. Miscellaneous Paper No. 6-286, Vicksburg, Miss., October 1958.
17. Wiley, A. J., "Past experience with high dams and outlook for the future." Transactions, American Society of Civil Engineers, vol 95 (1931), pp 130-138.

Table 1

Pressures Indicated in Calibration Tests

Applied Pressure (Nominal) psi	Average* Indicated Pressure, psi			
	Piezometer Tip	Walker-Pulli Cell	WES Cell	Carlson Cell
0.0	0.0	0.0	0.0	0.0
21.8	21.8	21.8	22.0	22.6
41.8	41.8	42.3	43.2	42.7
61.8	61.8	61.6	59.9	64.4
81.8	81.8	81.4	80.9	82.2
101.8	102.0	101.6	101.4	102.6
121.8	121.8	121.3	119.8	123.0
141.8	141.8	141.3	140.0	143.1
161.8	161.8	161.2	164.8	163.5
181.8	181.9	181.5	184.6	184.0
201.8	201.8	**	202.8	204.4
181.8	181.8	180.8	182.9	184.0
161.8	161.8	161.2	164.8	163.5
141.8	141.8	141.1	145.0	143.4
121.8	121.8	119.4	119.8	123.4
101.8	101.8	100.0	98.6	102.9
81.8	81.8	80.8	82.2	82.8
61.8	61.8	60.2	61.0	62.8
41.8	41.8	40.8	40.7	42.3
21.8	21.8	20.2	22.6	21.2
0.0	0.0	0.2	0.0	0.0

* Average of two runs.

** Not enough pressure in line to balance Walker-Pulli cell.

Table 2

Variations in Pressures Indicated in Calibration Tests

Applied Pressure (Nominal) psi	Average* Deviation from Applied Pressure, psi			
	Piezometer Tip	Walker-Pulli Cell	WES Cell	Carlson Cell
0.0	0.0	0.0	0.0	0.0
21.8	0.0	0.0	+0.2	+0.8
41.8	0.0	+0.5	+1.4	+0.9
61.8	0.0	-0.2	-1.9	+2.6
81.8	0.0	-0.4	-0.9	+0.4
101.8	+0.2	-0.2	-0.4	+0.8
121.8	0.0	-0.5	-2.0	+1.2
141.8	0.0	-0.5	-1.8	+1.3
161.8	0.0	-0.6	+3.0	+1.7
181.8	+0.1	-0.3	+2.8	+2.2
201.8	0.0	--	+1.0	+2.6
181.8	0.0	-1.0	+1.1	+2.2
161.8	0.0	-0.6	+3.0	+1.7
141.8	0.0	-0.7	+3.2	+1.6
121.8	0.0	-2.4	-2.0	+1.6
101.8	0.0	-1.8	-3.2	+1.1
81.8	0.0	-1.0	+0.4	+1.0
61.8	0.0	-1.6	-0.8	+1.0
41.8	0.0	-1.0	-1.1	+0.5
21.8	0.0	-1.6	+0.8	-0.6
0.0	0.0	+0.2	0.0	0.0

* Average of two runs.

Table 3

Pressures Indicated in First Series of Tests
Specimens 14 Days Old

Applied Pressure (Nominal) psi	Point on Specimen at Which Pressure Applied	Days of Test	Indicated Pore-Water Pressure, psi (to Nearest 0.5 lb)			
			Walker-Pulli Cell	Piezometer Tip	WES Cell	Carlson Cell
0		0	0.0	0.0	0.0	0.0
200	Top	1	169.0	170.0	183.5	125.0
200	Top	2	162.5	166.5	183.0	139.5
200	Top	5	149.0	150.5	177.0	134.5
200	Top	6	146.0	143.5	174.0	133.0
200	Top	7	141.5	137.5	171.5	129.0
200	Top	8	137.5	131.0	167.5	128.0
200	Top	9	135.0	127.0	172.0	126.5
200	Top	12	128.5	115.5	169.0	124.0
200	Top	13	128.0	110.5	164.0	125.0
200	Top	14	128.5	105.0	160.0	122.5
200	Top	15	126.0	102.5	157.0	122.0
200	Top	16	123.0	100.0	155.0	120.0
200	Top and bottom	19	191.0	160.0	187.0	190.5
200	Top and bottom	20	189.5	158.5	188.0	189.0
200	Top and bottom	21	191.0	156.5	188.5	190.5
200	Top and bottom	22	191.0	155.5	188.5	190.5
200	Top and bottom	23	---	185.0*	---	---
200	Top and bottom	27	---	188.5	---	---

* Piezometer tip was found to be leaking and was repaired.

Table 4

Pressures Indicated in First Series of Tests
Specimens 97 Days Old

Applied Pressure (Nominal) psi	Point on Specimen at Which Pressure Applied	Days of Test	Indicated Pore-Water Pressure, psi (to Nearest 0.5 lb)			
			Walker-Pulli Cell	Piezometer Tip	WES Cell	Carlson Cell
0		0	0.0	0.0	0.0	0.0
200	Top	1	85.5	119.5	120.0	15.5
200	Top	2	134.0	139.0	158.0	97.0
200	Top	3	---	---	---	153.5
200	Top	4	---	---	---	156.0
200	Top	6	174.0	152.5	178.5	---
200	Top	7	171.5	152.5	178.5	---
200	Top	8	171.5	153.0	180.0	160.0
200	Top	9	170.5	151.0	179.0	161.5
200	Top	10	168.5	149.5	179.0	163.0
200	Top	11	---	---	---	160.5
200	Top	14	174.5	148.5	181.5	155.5
200	Top	15	176.0	150.5	181.5	162.0
200	Top	16	172.5	150.5	182.5	162.0
200	Top and bottom	17	182.0	184.0	190.0	---
200	Top and bottom	18	---	---	---	177.5
200	Top and bottom	20	196.0	196.5	197.0	---
200	Top and bottom	21	196.0	197.5	197.5	177.5
200	Top and bottom	22	195.5	194.0	195.5	184.0
200	Top and bottom	23	---	---	---	184.5
200	Top and bottom	24	196.0	196.0	197.5	185.5
200	Top and bottom	25	---	---	---	184.5
200	Top and bottom	27	196.0	196.5	199.5	---
200	Top and bottom	28	193.5	198.5	203.0	183.0
200	Top and bottom	29	196.0	197.0	200.5	184.0

(Continued)

Table 4 (Concluded)

Applied Pressure (Nominal) psi	Point on Specimen at Which Pres- sure Applied	Days of Test	Indicated Pore-Water Pressure, psi (to Nearest 0.5 lb)			
			Walker- Pulli Cell	Piezometer Tip	WES Cell	Carlson Cell
200	Top and bottom	30	197.0	197.5	202.0	184.5
200	Top and bottom	31	196.5	197.0	201.0	184.0
200	Top and bottom	32	---	---	---	184.0
200	Top and bottom	34	195.5	195.5	199.5	---
200	Top and bottom	35	196.0	195.0	199.5	---
200	Top and bottom	36	196.5	195.0	199.5	---
200	Top and bottom	37	196.0	195.5	199.5	---
200	Top and bottom	38	196.5	195.0	199.5	---

Table 5

Pressures Indicated in Second Series of Tests
Specimens 174 Days Old and Inverted in Containers

Applied Pressure (Nominal) psi	Point on Specimen at Which Pressure Applied	Days of Test	Indicated Pore-Water Pressure, psi (to Nearest 0.5 lb)	
			WES Cell	Piezometer Tip
0		0	0.0	0.0
200	Top	1	1.0	0.0
200	Top	2	1.5	3.5
200	Top	3	3.0	14.5
200	Top	6	9.0	42.0
200	Top	7	11.0	48.5
200	Top	8	12.5	53.5
200	Top	9	13.5	58.5
200	Top	10	14.5	62.5
200	Top	13	18.0	77.0
200	Top	14	19.5	79.5
200	Top	15	20.5	77.5
200	Top	16	21.5	77.0
200	Top	17	22.5	77.0
200	Top	20	25.5	78.5
200	Top	21	27.0	81.5
200	Top	22	28.0	81.5
200	Top	23	28.5	82.5
200	Top	24	30.0	83.0
200	Top	27	31.5	83.0
200	Top	28	32.5	85.0
200	Top	29	33.5	86.0
200	Top	30	33.5	84.5
200	Top	31	34.0	87.0
200	Top	34	35.0	86.5

(Continued)

Table 5 (Concluded)

Applied Pressure (Nominal) psi	Point on Specimen at Which Pressure Applied	Days of Test	Indicated Pore-Water Pressure, psi (to Nearest 0.5 lb)	
			WES Cell	Piezometer Tip
200	Top	35	36.0	87.5
200	Top	36	36.5	87.0
200	Top	37	37.5	87.5
200	Top	41	39.0	90.5
200	Top	42	40.0	90.5
200	Top	43	40.0	89.5
200	Top	44	40.0	89.5
200	Top	45	41.0	90.5
200	Top	48	42.5	90.5
200	Top	49	42.5	90.5
200	Top	50	43.0	89.5
200	Top	51	43.5	90.0
200	Top	52	43.5	88.0
200	Top	55	44.5	90.5
200	Top	56	45.0	90.0
200	Top	57	45.0	89.0
200	Top	58	45.0	90.0
200	Top	59	45.0	89.0
200	Top	63	44.0	88.5

Table 6

Pressures Indicated in Third Series of Tests

Specimens 14 Days Old

Applied Pressure (Nominal) psi	Point on Specimen at Which Pres- sure Applied	Days of Test	Indicated Pore-Water Pressure, psi (to Nearest 0.5 lb)		
			Piezometer Tip	WES Cell	Carlson Cell
0		0	0.0	0.0	0.0
200	Top	1	184.0	180.0	146.0
200	Top	4	183.0	182.5	163.0
200	Top	5	183.5	182.0	163.0
200	Top	6	183.5	180.5	161.5
200	Top	7	185.5	181.5	163.5
200	Top	8	182.5	179.0	162.0
200	Top	11	186.0	180.0	163.0
200	Top	12	182.5	178.0	162.0
200	Top	13	184.0	178.5	163.5
200	Top	14	187.5	180.5	165.0
200	Top	15	189.0	182.0	167.0
200	Top	18	183.5	178.0	164.0
200	Top and bottom	19	192.0	200.5	187.5
200	Top and bottom	20	197.0	203.0	190.0
200	Top and bottom	21	188.0	188.0	172.5
200	Top and bottom	22	185.5	183.0	168.0

Table 7

Pressures Indicated in Third Series of Tests

Specimens 90 Days Old

Applied Pressure (Nominal) psi	Point on Specimen at Which Pressure Applied	Days of Test	Indicated Pore-Water Pressure, psi (to Nearest 0.5 lb)		
			Piezometer Tip	WES Cell	Carlson Cell
0		0	0.0	0.0	0.0
200	Top	1	184.5	3.5	25.5
200	Top	2	197.0	35.0	82.5
200	Top	3	---	74.5	---
200	Top	5	197.0	---	152.5
200	Top	6	196.0	128.0	156.0
200	Top	7	197.0	134.0	157.0
200	Top	8	196.0	136.0	157.5
200	Top	9	195.0	138.5	157.5
200	Top	10	---	141.0	---
200	Top	12	196.0	---	159.0
200	Top	13	195.0	---	158.5
200	Top	14	195.0	159.0	158.5
200	Top	15	196.0	170.5	158.5
200	Top	16	195.0	171.5	158.5
200	Top and bottom	17	---	172.0	---
200	Top and bottom	19	193.5	---	181.0
200	Top and bottom	20	194.0	178.0	180.5
200	Top and bottom	21	193.5	180.0	181.0
200	Top and bottom	22	195.0	181.0	181.0
200	Top and bottom	23	193.5	181.0	181.0
200	Top and bottom	24	---	182.5	---
200	Top and bottom	26	192.0	---	180.5
200	Top and bottom	27	195.0	179.0	180.5
200	Top and bottom	28	194.0	181.5	182.5
200	Top and bottom	29	193.0	183.0	182.5
200	Top and bottom	30	---	181.0	---
200	Top and bottom	31	---	184.5	---
200	Top and bottom	34	---	182.0	---