

AD-A073 329

OREGON STATE UNIV CORVALLIS SCHOOL OF OCEANOGRAPHY
EXPOSURE. A NEWSLETTER FOR OCEAN TECHNOLOGISTS. VOLUME 7. NUMBER 1
JUL 79 R MESECAR

F/6 13/3

NUMBE--ETC(U)

N00014-79-C-0004

NL

UNCLASSIFIED

| OF |

AD
A073329



END
DATE
FILMED
10-79
DOC

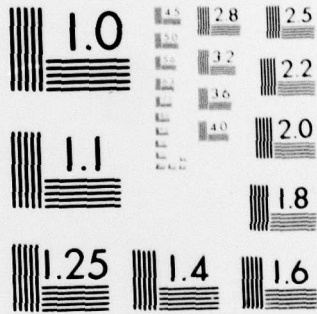

MICROCOPY RESOLUTION TEST CHART
 NATIONAL BUREAU OF STANDARDS-1963-A

12

EXPOSURE

D D C
R
AUG 29 1979
C

vol. 7 no. 3 **LEVEL** a newsletter for ocean technologists

A070453 See 1473 in back

A Portable Data Collection Winch Without Slip Rings For Arctic Use

Experience gained in the Arctic, working in both winter and summer, from rubber boats, aeroplanes landing on the sea ice, ships, and Skidoo-type vehicles prompted the development of a portable, self-contained winch for shallow waters (250 m). Our particular requirements dictated a number of unusual features, resulting in this winch being developed "in-house," as no suitable commercial product was available. The concept kept in mind was that the winch was to be self-contained, portable, virtually noise-free from electrical/mechanical interference, and that cables, sensors, and recording packages could be easily changed according to the task.

Winch Description

The winch is mounted on a 24-inch x 25-inch base, (see Figure 1). The center of gravity is kept low by supporting the outrigger boom on the side of small boats, "hi-lining" it to a ship's side, or "stiff-legging" it to the ice. The winch is quite stable and requires little in the way of hold-down support. The minimum outrigger pulley diameter was selected for the mechanical bending properties of the selected cable. Recording electronics, heaters, and insulation (for Arctic use) are contained inside the 12-inch-diameter winch drum, eliminating the need for slip rings. The 12 V dc rewind motor, clutch, gearing, sprockets, and chains are all commercially available. One end of the winch allows access to the data collection system. The 2 inches between the printer face and the plastic Lexan splash shield allow space for the printed tape to collect. This shield is easily removed by releasing a retaining ring, which

July 1979

- 1 -
79 08 27 096

AD A 073329

DDC FILE COPY



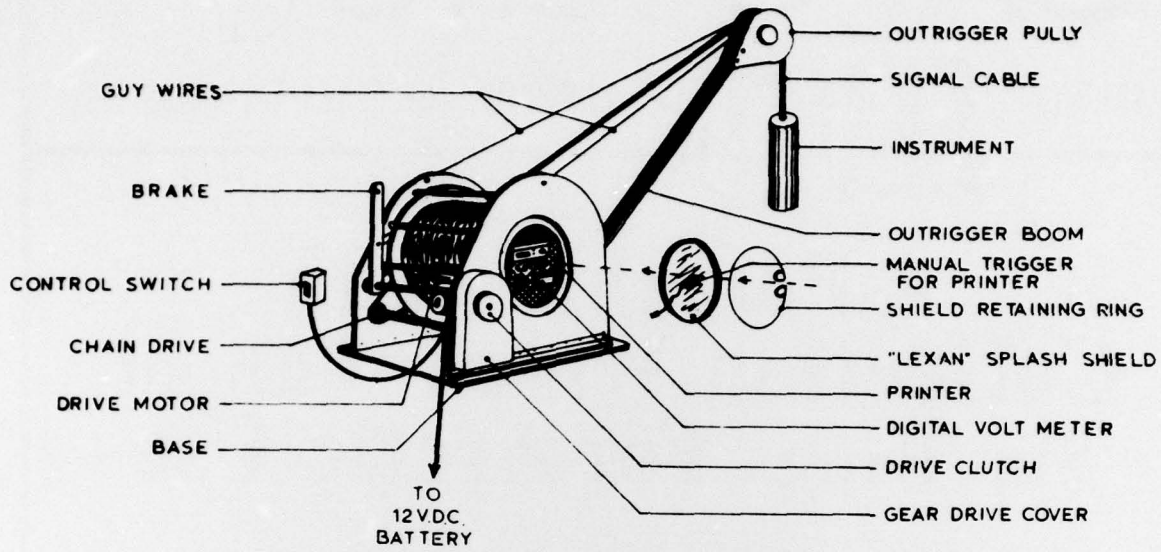

data collection winch

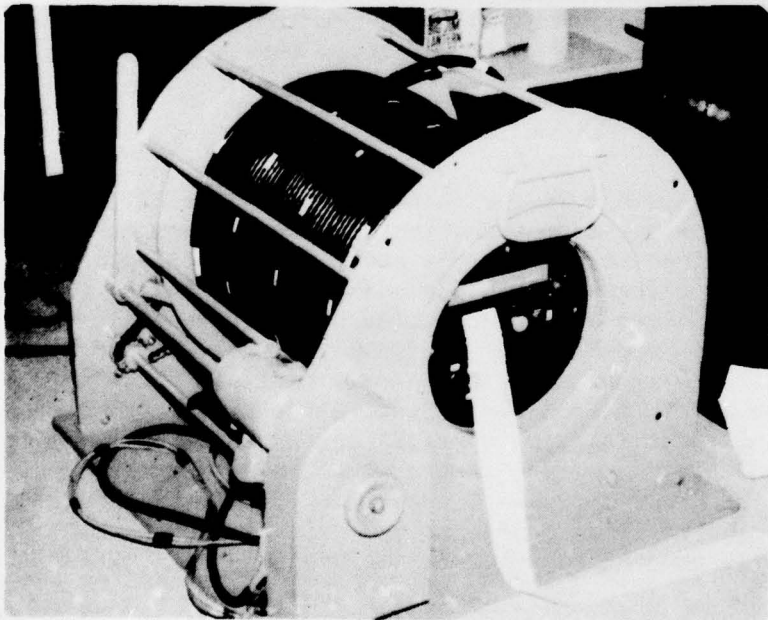

figure
1

Unclassified

SECURITY CLASSIFICATION OF THIS PAGE (When Data Entered)

REPORT DOCUMENTATION PAGE		READ INSTRUCTIONS BEFORE COMPLETING FORM
1. REPORT NUMBER Vol. 7, No. 3	2. GOVT ACCESSION NO.	3. RECIPIENT'S CATALOG NUMBER
4. TITLE (and Subtitle) <u>EXPOSURE</u> A newsletter for ocean technologists, Volume	5. TYPE OF REPORT & PERIOD COVERED <u>9</u> technical report	6. PERFORMING ORG. REPORT NUMBER
7. AUTHOR(s) <u>10</u> Roderick/Mesecar	8. CONTRACT OR GRANT NUMBER(s) <u>15</u> N00014-79-C-0004	
9. PERFORMING ORGANIZATION NAME AND ADDRESS School of Oceanography Oregon State University, Corvallis 97331	10. PROGRAM ELEMENT, PROJECT, TASK AREA & WORK UNIT NUMBERS NR 083-103	
11. CONTROLLING OFFICE NAME AND ADDRESS <u>12</u> 9 P.	12. REPORT DATE <u>11</u> July 1979	13. NUMBER OF PAGES 8
14. MONITORING AGENCY NAME & ADDRESS (if different from Controlling Office)	15. SECURITY CLASS. (of this report) (U)	15a. DECLASSIFICATION/DOWNGRADING SCHEDULE
16. DISTRIBUTION STATEMENT (of this Report) Approved for public release; distribution unlimited		
17. DISTRIBUTION STATEMENT (of the abstract entered in Block 20, if different from Report)		
18. SUPPLEMENTARY NOTES Published every two months by the School of Oceanography Oregon State University, Corvallis, OR 97331		
19. KEY WORDS (Continue on reverse side if necessary and identify by block number) Ocean technology; instrumentation		
20. ABSTRACT (Continue on reverse side if necessary and identify by block number) A Portable Data Collection Winch Without Slip Rings For Arctic Use A Transmissometer for the Measurement of Suspended Sediment Concentration and Transport		

272 268

slr

allows access for maintenance, the removal of the data tape, or the connection of the thermostatically controlled, 110 V ac, heater line, which also charges the batteries supplying the internal electronics. An external 12 V dc source can also be used to charge the batteries. Both the 110 V ac and the 12 V dc lines must be disconnected before use. The drum is chain-driven and supported on that end by a flange-mounted bearing and stub shaft. The other end of the drum is supported on the exterior by nylon or aluminum rollers. The aluminum rollers proved a little noisy, but quite satisfactory, and to date no excess wear has been noted. During descent, the winch free-wheels out, easily controlled by the overly generous handbrake. It may be locked at desired depths by a deadbolt lock or by the motor clutch. The entire winch, complete with 200 m of wire, weighs approximately 120 lb, making it easily handled in and out of small boats. Some difficulty has been experienced with wire separation in the data cable; this appears to be mechanical damage due to bending the cable too tightly in handling.

Data Collection System

This consisted of a multiplexer preceding a Newport Model 2003, 4-figure, digital voltmeter (DVM) coupled to a Datal DPP7 Printer--the whole system being powered by 5 V dc. Our first application was to do profiles of conductivity/temperature using a cell designed and developed within the group. Profile triggering was accomplished by manual triggering with the press button in the center of the Lexan shield when the premeasured, marked data signal cable was stopped at desired depths. Magnetic tape recording was discussed, and may well be used in future projects, but it was felt that the visual digital meter and printed tape gave more immediate results to allow in-field adjustments during trials.

Conclusion

The winch satisfactorily handles the sensors weighing up to 50 lb, exclusive of cable weight, which will cover most sensors we normally use. We have used the winch while operating from Zodiac rubber boats in the summer and through 12-inch holes in the Arctic sea ice during winter. It has proven compact enough for our use, and to date has suffered no mechanical failures other than the cable. The drum will hold approximately 200 m of 3/8-inch cable and the spooling angle makes it easy to handfeed the cable onto the drum at its nominal 0.5 m/s rewind rate. A single 60-Ah, 12-V battery will allow approximately 5 hours of rewind spooling.

FOR FURTHER INFORMATION, CONTACT:

Dennis Richards
Frozen Sea Research Group
Institute of Ocean Sciences
Patricia Bay
9860 West Saanich Road, Box 6000
Sidney, B.C. CANADA
V8L 4B2



Dennis Richards has been a member of the Frozen Sea Research Group for the past 9 years, working primarily in the Canadian High Arctic. A machinist by trade, his primary function is the designing and building of electro/mechanical equipment for the Frozen Sea Research Group.

A Transmissometer For The Measurement Of Suspended Sediment Concentration And Transport

The optical oceanography group at Oregon State University has developed a beam transmissometer with a 25 cm light path to measure suspended sediment concentration in water.

The instrument measures beam transmission, a well-defined optical parameter, so that the theoretical relationship between particle parameters (size, shape, and index of refraction) and the optical parameter via Mie's theory is straightforward. The instrument is designed for maximum repeatability and minimum power requirements.

The light intensity in a well-collimated beam of light decreases exponentially as given by

$$I(r) = I(0) e^{-cr}, \quad (1)$$

where $I(r)$ is the light intensity at distance r from the source and c is the beam attenuation coefficient. If

$cr = 1$, the light intensity will have decreased by $1/e$ when it is measured. A beam transmissometer tends to be most accurate in the region where c is on the order of $1/r$, since in this region cr is not too close to zero and, on the other hand, the signal is also large enough that one is not trying to measure very low light intensities. Since the instrument is designed for relatively shallow depths (300 m maximum), r was set at 25 cm, giving optimum performance within one and a half orders of $c = 4 \text{ m}^{-1}$.

The light source is a light emitting diode (LED) with a wavelength of 660 nm. This wavelength choice was generated by our desire to eliminate attenuation due to dissolved humic acids (the so-called "yellow matter"). The yellow matter absorbs light strongly at the shorter wavelengths, but this effect can be ignored for wavelengths larger than 660 nm.

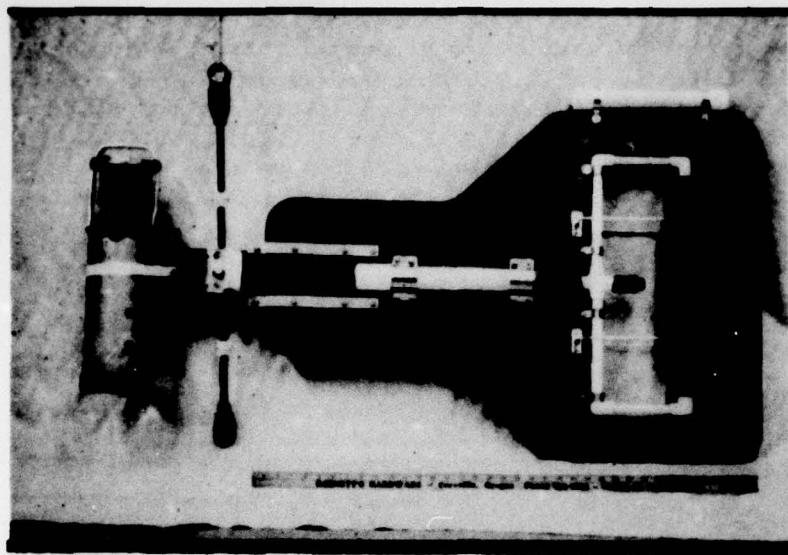

figure
1

Figure 1 shows the transmissometer mounted in an Aanderaa current meter vane. This configuration permits the direct measurement of sediment transport.

The transmissometer pressure housing has a 300-m depth capability and is constructed from standard P.V.C. tubing to minimize costs and eliminate problems with corrosion. A collimated light source and optical receiver are located 25 cm apart and are connected by three stainless steel threaded rods. Optical alignment is accomplished by adjusting the length of each connecting rod. Two light stops are placed between the receiver and light source to prevent receiver saturation by direct sunlight entering the receiver. Input power and output signals are fed through a multipin marine connector located at the top of the pressure housing. The P.V.C. surfaces adjacent to the light path are painted with antifouling paint to prevent blocking of the light path by marine growth.

Optical design of the collimated light source is very simple: the lens used is both the pressure window and collimating element. The plano-convex lens (diameter = 22.4 mm,

focal length = 40 mm) is installed so that the flat side is in contact with the water. A LED and a temperature-sensing diode are potted into a threaded assembly so that the LED can be positioned at the lens focal point in order to collimate the light source. Electro-optical characteristics of the LED, MV5020, are: lens color, clear; lens radius, 2 mm; peak wavelength, 660 nm; spectral line half width, 20 nm; half power point, 45° ; and apparent area (circular), $0.828 \times 10^{-3} \text{ cm}^2$. The resultant light source beam parameters are: beam diameter, 20 mm; beam divergence, 0.5° ; and radiated output power, 3×10^{-7} watt.

The optical receiver consists of a lens having identical characteristics to the one used in the light source with a silicon photovoltaic detector located at the focal point. The detector is potted into a threaded assembly to enable alignment of the detector. The detector used is an EG&G, Inc., PV100A, and has the following characteristics: active area, 5.1 mm^2 ; spectral range, 350-1150 nm; and responsivity at 660 nm, 0.33 amp/watt. Receiver parameters are: aperture, 20 mm; and acceptance angle, 1.82° .

The transmissometer electronics, shown schematically in Figure 2, supplies regulated power, generates a modulated, temperature-compensated, drive voltage to the LED and synchronously detects the amplified detector signal.

Power requirements for the transmissometer are 8 to 15 V dc at approximately 10 mA, which is normally supplied by a 12 V dc lattern battery. Power is fed through a blocking diode (D1) to prevent damage to the circuitry in case reverse polarity is applied to the power terminals. The + 7.5 V regulated supply consists of FET(Q1), operational amplifier (A2A), a

2.5 V dc reference (VR), and resistors R1 and R2. An astable multivibrator (IC1), in conjunction with FET switch (IC2), and the diode rectifier filter (D2, D3, C5, C6), generate a negative voltage which is regulated to -2.5 V dc by A2B, R3, and R4.

LED drive voltage is supplied by A1B through R13. The input signal to A1B is the sum of the + 2.5 V dc reference voltage (VR) and the negative output from the temperature compensation circuit (A1A, D5, and R6). The resistor-divider ratio of R7, R8 and R9 is adjusted to temperature compensate the radiated output power of the LED. Modulation

figure 2

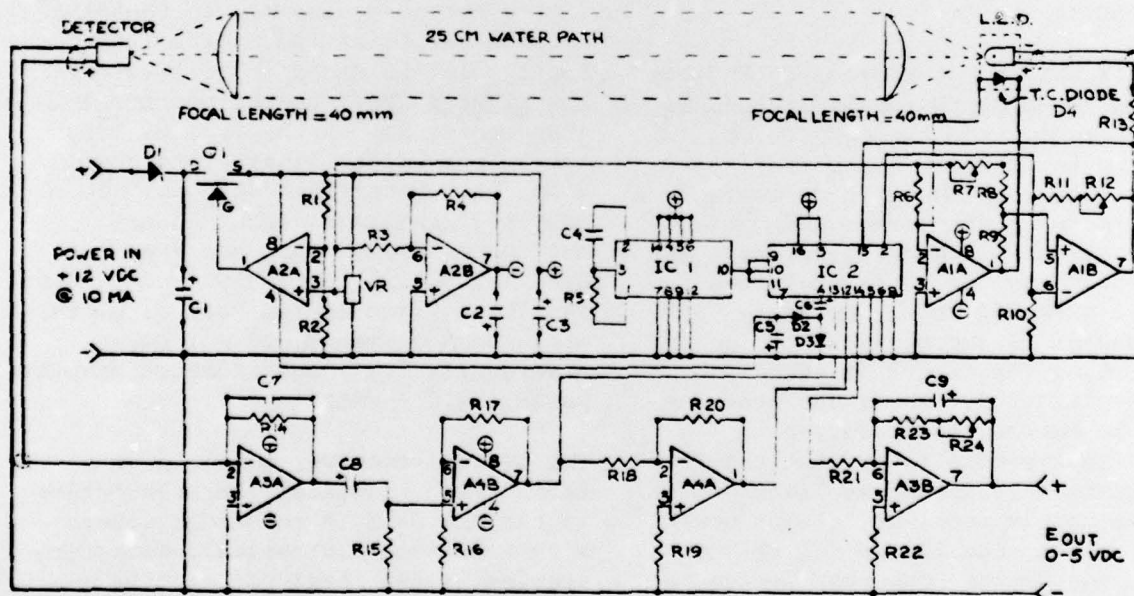

R1, R3, R4, R6, R15, R16, R21 - 20 K ohm
 R2, R18, R20 - 10 K ohm
 R5, R14 - 499 K ohm
 R7 - 1 K ohm potentiometer
 R8, R11 - *4.99 K ohm (nominal)
 R9, R19 - 4.99 K ohm
 R10, R12 - 1 K ohm
 R13 - 470 ohm
 R17 - *499 K ohm (nominal)
 R22 - 16.9 K ohm
 R23 - 82.5 K ohm
 R24 - 20 K ohm potentiometer
 C1, C8-10 μ F, 25 VDC
 C2, C3, C9-1 μ F, 35 VDC

C4 - 1000 PF
 C5, C6 - 15 μ F, 16 VDC
 C7 - 5 PF
 D1, D2, D3 - 1N270
 D4 - 1N4454
 A1, A2, A3, A4 - LM358N
 IC1 - CD4047AE
 IC2 - CD4053BE
 Q1 - 2N5434
 VR - AD580M
 DETECTOR - PV100A
 LED - MV5020
 LENS - PLANO-CONVEX, F.L. 40 MM
 * These resistors are selected at test.

of the LED output is accomplished by switching the gain of A1B with a FET switch in IC2.

The detector output current is amplified by the current to voltage converter (A3A, R14, C7), and then ac coupled by capacitor C8 to remove any dc component in the received signal caused by ambient light incident on the detector. Amplifiers A4B and A4A then produce "0°" phase and "180°" phase signals which are synchronously detected by a SPDT-FET switch in IC2. The output from the synchronous detector is then amplified and filtered by A3B, R21, R22, R23, R24, and C9. The output voltage from A3B is calibrated by R24 so that 0 to 5 V dc corresponds to 0 to 100 percent transmission in water.

Calibration of the transmissometer includes alignment, temperature compensation, and adjustment of the receiver gain to obtain an output voltage corresponding to 90 percent transmission in filtered distilled water.

Alignment in air is achieved by first collimating the light source so that the transmitted beam at 25 cm is slightly smaller than the receiving aperture and is centered on the receiver lens; the receiver is aligned next to obtain maximum output. During alignment, the LED drive voltage, at the output of A1B, is set to 4.5 V peak. After the light source and optical receiver have been aligned, R17 is selected to obtain -1 V dc at pin 14 of IC2. The transmissometer is then installed in a temperature-control chamber and, with R7 and R12 set in the middle of their range, temperature is cycled between 0°C and 25°C. R8 is then selected to temperature compensate the LED and R11 is selected to maintain a 4.5 V peak drive to the LED at pin 7 of A1B.

After the transmissometer has been aligned and temperature compensated, it is immersed in filtered, distilled water, $\beta(45^\circ)$ at $550 \text{ nm} \leq 7 \times 10^{-4} \text{ m}^{-1} \text{ ster}^{-1}$. The transmission of this water was 65.5 percent as measured by a 1-m beam transmissometer. By applying equation (1) we convert from transmission readings on the 1-m transmissometer, $T(1 \text{ m})$, to readings on the 25-cm transmissometer, $T(0.25 \text{ m})$. Since

$$T(1 \text{ m}) = e^{-c}, \quad c = -\ln T(1 \text{ m})$$

and hence

$$T(0.25 \text{ m}) = e^{(0.25) \ln T(1 \text{ m})} \quad (2)$$

A reading of 65.5 percent transmission on the 1-m beam transmissometer is found by means of equation (2) to correspond to a 90.0 percent transmission reading on the 25-cm transmissometer.

After the instrument has been immersed, the receiver gain, R24, is set so that the output voltage is 4.50 V dc which, for this transmissometer, corresponds to 90.0 percent transmission in water. The unit is then removed from water and the voltage reading in air is recorded. This air reading can be checked periodically to verify that the instrument calibration is stable over a period of time.

The transmissometer overall error due to electronics, temperature compensation, and instability is less than 0.5 percent.

Recently, the transmissometer has been redesigned (see Figure 3) to permit installation in a standard Aanderaa vane without changing the total area of the vane. The electronics is the same as in the previous design; the optics has been improved by using achromatic lenses (60 mm focal length) and windows in place of the single plano-convex

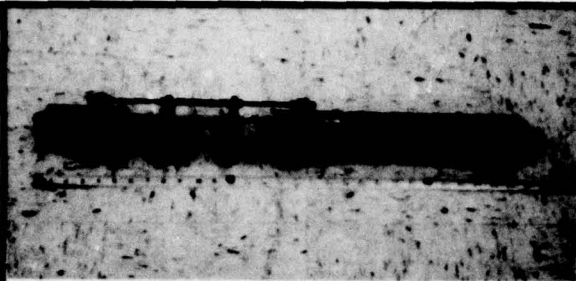

figure 3

lenses. The depth capability of the instrument has been increased to 750 m. The new design does not, however, permit the incorporation of temperature and depth probes in the same housing.

Details regarding this instrument and its interface to an Aanderaa current meter and CTD systems are available from the authors.

REFERENCE:

Bartz, Zaneveld, and Pak, "A Transmissometer for Profiling and Moored Observations in Water," *SPIE* Vol 160 Ocean Optics V, 1978.

FOR FURTHER INFORMATION, CONTACT:

Robert Bartz, J. Ronald V. Zaneveld,
or Hasong Pak
Optical Oceanography Group
School of Oceanography
Oregon State University
Corvallis, OR 97331

Telephone (503) 754-2692

T A B L E O F C O N T E N T S

Page	Article	Author
1	A Portable Data Collection Winch Without Slip Rings For Arctic Use	Richards
4	A Transmissometer For The Measurement Of Suspended Sediment Concentration And Transport	Bartz/ Zaneveld/ Pak

Dr. Rod Mesecar, Editor
E X P O S U R E
School of Oceanography
Oregon State University
Corvallis, OR 97331

Telephone: (503) 754-2206

Accession For	
NTIS GRAB	<input checked="" type="checkbox"/>
DDO TAB	<input type="checkbox"/>
Unannounced	<input type="checkbox"/>
Justification	<input type="checkbox"/>
By _____	
Distribution/	
Availability Codes	
Dist	Avail and/or special
A	

FIRST CLASS