

DTNSRDC-SME-78/77

ULTRAFILTRATION OF BLACKWATER FOR MARINE VESSEL APPLICATION

ADA 071 618

DDC FILE COPY

B.S.

# DAVID W. TAYLOR NAVAL SHIP RESEARCH AND DEVELOPMENT CENTER



Bethesda, Maryland 20884

# LEVEL

## ULTRAFILTRATION OF BLACKWATER FOR MARINE VESSEL APPLICATION

By  
L. R. Harris and M. Sandate

APPROVED FOR PUBLIC RELEASE: DISTRIBUTION IS UNLIMITED.

DDC  
RECEIVED  
JUL 25 1979  
RESOLIVE  
A

SHIP MATERIALS ENGINEERING DEPARTMENT  
RESEARCH AND DEVELOPMENT REPORT

July 1979

Best Available Copy DTNSRDC-SME-78/77

79 07 24 005

## MAJOR DTNSRDC ORGANIZATIONAL COMPONENTS

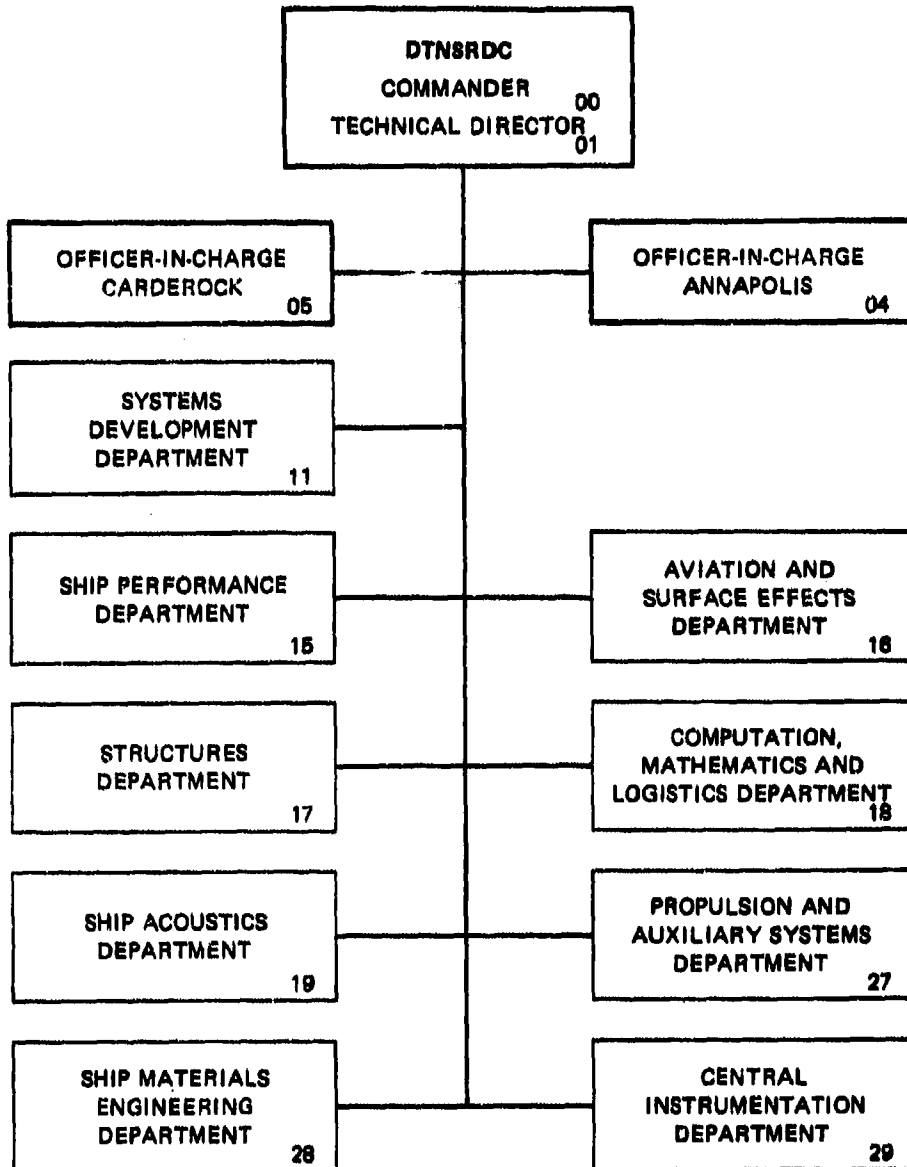

UNCLASSIFIED

SECURITY CLASSIFICATION OF THIS PAGE (When Data Entered)

REPORT DOCUMENTATION PAGE

READ INSTRUCTIONS BEFORE COMPLETING FORM

1. REPORT NUMBER DTNSRDC/SME-78/77		2. GOVT ACCESSION NO.		3. RECIPIENT'S CATALOG NUMBER 9	
4. TITLE (and Subtitle) ULTRAFILTRATION OF BLACKWATER FOR MARINE VESSEL APPLICATION				5. TYPE OF REPORT & PERIOD COVERED Final Report	
7. AUTHOR(s) L. R. Harris and M. Sandate				8. CONTRACT OR GRANT NUMBER(s) MIPR A-7178	
9. PERFORMING ORGANIZATION NAME AND ADDRESS David W. Taylor Naval Ship R&D Center Annapolis, MD 21402				10. PROGRAM ELEMENT, PROJECT, TASK AREA & WORK UNIT NUMBERS 672720, 1F762720D048, 07 WU 1-2861-508	
11. CONTROLLING OFFICE NAME AND ADDRESS U. S. Army Mobility Equipment R&D Command Petroleum & Environmental Technology Division Fort Belvoir, VA 22060				12. REPORT DATE Jul 79	
14. MONITORING AGENCY NAME & ADDRESS (if different from Controlling Office) 35 p.				13. NUMBER OF PAGES 31	
				15. SECURITY CLASS. (of this report) UNCLASSIFIED	
				15a. DECLASSIFICATION/DOWNGRADING SCHEDULE	
16. DISTRIBUTION STATEMENT (of this Report) APPROVED FOR PUBLIC RELEASE: DISTRIBUTION UNLIMITED.					
17. DISTRIBUTION STATEMENT (of the abstract entered in Block 20, if different from Report)					
18. SUPPLEMENTARY NOTES					
19. KEY WORDS (Continue on reverse side if necessary and identify by block number) Ultrafiltration                      Suspended solids Tubular membrane                  Fecal coliform bacteria Sewage Anaerobic					
20. ABSTRACT (Continue on reverse side if necessary and identify by block number) The United States Army currently is investigating waste treatment technology for processing marine vessel wastewater. This has become necessary in order to satisfy Environmental Protection Agency marine discharge regulations. As an interim measure, the Army is installing collection, holding, and transfer tanks aboard their watercraft. Because of physical limitations, many of the collection, holding, and transfer tanks do not provide adequate holding capacity.					

(Continued on reverse side)

cont  
mit



## TABLE OF CONTENTS

	<u>Page</u>
LIST OF FIGURES . . . . .	iii
LIST OF TABLES . . . . .	iv
LIST OF ABBREVIATIONS . . . . .	v
ABSTRACT . . . . .	1
ADMINISTRATIVE INFORMATION . . . . .	1
INTRODUCTION . . . . .	2
OBJECTIVE . . . . .	2
BACKGROUND . . . . .	2
INVESTIGATION . . . . .	3
DESCRIPTION OF MEMBRANES . . . . .	3
DESCRIPTION OF TEST SYSTEM . . . . .	4
RESULTS AND DISCUSSION . . . . .	5
FLUX PERFORMANCE . . . . .	5
MEMBRANE REJECTION OF SUSPENDED SOLIDS AND FECAL COLIFORM BACTERIA . . . . .	8
PRETREATMENT AND CLEANING OPERATIONS . . . . .	9
PARAMETRIC STUDY . . . . .	9
REQUIREMENTS FOR PROTOTYPE SYSTEM . . . . .	11
SUMMARY OF FINDINGS AND CONCLUSIONS . . . . .	13
REFERENCES . . . . .	25

### LIST OF FIGURES

1 - Ultrafiltration Test System Schematic . . . . .	15
2 - Test Setup . . . . .	16
3 - Effect of Pressure on Initial Water Flux . . . . .	17
4 - Flux Vs Time Performance of Half-Inch Tubular Ultrafiltration Membranes Processing Nonaerated Raw Sewage . . . . .	17
5 - Comparison of Tubular (TI) Membranes Processing Nonaerated Raw Sewage . . . . .	18
6 - Flux Performance of Tubular Membranes TI(C), TII(B), and the Effect of Suspended Solids, Test 2 . . . . .	18
7 - Effect of Pressure on Flux of TII(B) at Constant Circulation Rate and 70° F (21°C) . . . . .	19
8 - Effect of Pressure on Flux of TII(B) at Constant Circulation Rate and 80° F (27°C) . . . . .	19

	<u>Page</u>
9 - Effect of Pressure on Flux of TII(B) at Constant Circulation Rate and 100° F (38° C) . . . . .	20
10 - Effect of Pressure on Flux of TII(B) at Constant Temperature and 5 Gal/Min (19 L/Min) . . . . .	20
11 - Effect of Pressure on Flux of TII(B) at Constant Temperature and 7.5 Gal/Min (28 L/Min) . . . . .	21
12 - Effect of Pressure on Flux of TII(B) at Constant Temperature and 10 Gal/Min (38 L/Min) . . . . .	21
13 - Effect of Pressure on Flux of TII(B) at Constant Temperature and 15 Gal/Min (57 L/Min) . . . . .	22
14 - Effect of Temperature on Flux of TII(B) at Constant Pressure and 5 Gal/Min, 7.5 Gal/Min . . . . .	22
15 - Effect of Temperature on Flux of TII(B) at Constant Pressure and 10 Gal/Min, 15 Gal/Min . . . . .	23
16 - Effect of Pressure on Flux of TI(C) at Constant Circulation Rate and Temperature . . . . .	23
17 - Effect of Temperature on Flux of TI(C) at Constant Pressure and Circulation Rate . . . . .	24
18 - Effect of Temperature on Flux of TI(C) at Constant Pressure and Circulation Rate . . . . .	24

LIST OF TABLES

1 - Characteristics of Tubular Membranes . . . . .	4
2 - Membrane Operating Limits . . . . .	4
3 - Summary of Feed Tank and Permeate Quality . . . . .	8
4 - Recovered Membrane Flux After Completion of Parametric Study . . . . .	11
5 - Estimated Requirements for Ultrafiltration Blackwater Marine Vessel Treatment System . . . . .	13

## LIST OF ABBREVIATIONS

CHT	Collection, holding, and transfer tank
cm	Centimeter
cm <sup>3</sup>	Cubic centimeter
°C	Degree Celsius
°F	Degree Fahrenheit
DTNSRDC	David W. Taylor Naval Ship R&D Center
EPA	Environmental Protection Agency
et al	And others
ft	Foot
ft <sup>2</sup>	Square foot
gal/ft <sup>2</sup> /day	Gallon per square foot per day
gal/min	Gallon per minute
ID	Inside diameter
i.e.	That is
kPag	KiloPascal gage
kW-hr	Kilowatt-hour
l/min	Liter per minute
m	Meter
m <sup>3</sup>	Cubic meter
m <sup>2</sup>	Square meter
m <sup>3</sup> /m <sup>2</sup> /day	Cubic meter per square meter per day
mg/l	Milligram per liter
ml	Milliliter
No.	Number
ppm	Part per million
psi	Pounds per square inch

PVC Polyvinyl chloride  
UF Ultrafiltration  
U.S. United States  
H<sub>2</sub>S Hydrogen sulfide

I  
I  
I  
I  
I  
I  
I  
I  
I  
I  
I  
I



## ABSTRACT

The United States Army currently is investigating waste treatment technology for processing marine vessel wastewater. This has become necessary in order to satisfy Environmental Protection Agency marine discharge regulations. As an interim measure, the Army is installing collection, holding, and transfer tanks aboard their watercraft. Because of physical limitations, many of the collection, holding, and transfer tanks do not provide adequate holding capacity. Concentration is one method of extending holding tank capacity. A candidate system is ultrafiltration.

Two manufacturers' ultrafiltration membranes were evaluated with blackwater. Half-inch (1.2 centimeter) tubular membrane configurations were investigated. Membrane TI was commercially available. Membrane TII was specially prepared for this evaluation using half-inch tubular supports. In order to satisfy Army maintainability and reliability requirements, no pretreatment, aeration or cleaning were provided for either membrane. Depressurization of the membranes overnight or over the weekend provided sufficient flux recovery that membrane cleaning was unnecessary.

Experimental results indicated that Membrane TII produced a 3-fold higher flux than Membrane TI. Both membranes' effluents satisfied marine discharge regulations for suspended solids and fecal coliform bacteria. Steady state fluxes observed for the membranes were probably due to conducting the test anaerobically. Hydrogen sulfide produced during ultrafiltration-anaerobic processing of blackwater may present a problem for Army watercraft.

An economic comparison of the membranes could not be made because of the commercial nonavailability of the TII membrane. Although the power requirements of this membrane were approximately 15-fold less than Membrane TI, the commercial price of TII will ultimately determine the tradeoff between the two membranes.

## ADMINISTRATIVE INFORMATION

This work was funded by the United States Army Mobility Equipment Research and Development Command under MIPR A-7178. The technical monitor for the Army was Mr. D. S. Lent. Two preliminary copies of this report have been forwarded to the Army under DTNSRDC ltr 2861:LRH, 9593 of 2 August 1978. Work Unit number was 1-2861-508.

## INTRODUCTION

### OBJECTIVE

The objective was to evaluate the performance of 0.5 inch (1.25 cm)\* tubular UF membranes for processing blackwater (raw sewage) under anaerobic conditions.

### BACKGROUND

The U. S. Army is currently investigating available technology for processing marine vessel wastewater in order to develop shipboard systems that will allow the vessels to comply with existing and future environmental regulations. Various commercially available treatment system designs which performed satisfactorily in land based applications do not meet Army vessel requirements. Some of the problems encountered include excessive weight, space, treatment capacity, poor reliability and maintainability, and cost. Many of these systems also require the services of a trained operator. Because the complement on Army vessels have specific assignments, a marine treatment system must be capable of unattended operation for extended periods.

Current EPA regulations for marine sanitation devices discharging into navigable water<sup>1\*\*</sup> require the effluent to have a fecal coliform bacteria density <1000/100 ml and no visible floating solids. By January 1980, the effluent must have a fecal coliform density <200/100 ml and a suspended solids content <150 mg/l. The regulations further state that there will be no discharge of untreated blackwater in inland waters.

The Army has elected to install CHT's aboard their watercraft as an interim measure. The tanks are designed to collect and to hold blackwater until it can be transferred to a dedicated barge or to a shore-side facility. However, in many cases, the vessels do not have adequate holding

---

\*Definitions of abbreviations may be found on page v.

\*\*A complete listing of references can be found on page 25.

capacities because of physical limitations. As a result, the vessel would have to discharge wastes in violation of the regulations. It is apparent, then, that a process is required which can extend the CHT tank holding capacity. One way is by waste concentration, discharging an effluent complying with the marine discharge criteria. A candidate system is one based upon UF, a pressure-driven membrane process.

Recent investigations of UF have established its feasibility for processing blackwater under aerobic<sup>2-5</sup> and anaerobic conditions.<sup>6</sup> A 1-inch (2.5 cm) tubular UF membrane was shown to be more effective in processing blackwater than other available membrane configurations, including spiral wound, hollow fiber, and plate and frame.<sup>2,5</sup> These studies suggested that higher packing density (surface area/volume) tubular membrane systems, requiring minimum if any pretreatment, would be even more attractive for marine application. The present study evaluates the performance of two manufacturers' 0.5 inch (1.2 cm) tubular UF membranes processing nonaerated blackwater.

## INVESTIGATION

### DESCRIPTION OF MEMBRANES

One tubular membrane configuration, hereafter designated as TI, is commercially available. All membranes evaluated of this type in the present study were supported by specially fabricated 0.75-inch (1.9 cm) PVC tubular housings. A second membrane is commercially available but only in spiral wound or 1-inch (2.5 cm) tubular configurations. The tubular membranes of this type, (TII), were specially prepared on 0.5-inch (1.2 cm) ID tubular supports and fitted into 1-inch (2.5 cm) ID housings.

Three TI membranes were evaluated. These are designated TI(A), TI(B), and TI(C). Two of the TII membranes were evaluated. These are designated as TII(A) and TII(B).

Table 1 summarizes the characteristics of the two different non-cellulosic tubular membranes. Plastic adapters were used to connect the TI membranes to the test loop. These fittings reduced the inlet and outlet of each TI membrane to approximately 0.8-cm ID. Each adapter was approximately 2.5 cm long. No adapters were required for the TII membranes.

TABLE 1 - CHARACTERISTICS OF TUBULAR MEMBRANES

Membrane Designation	Approximate Molecular Weight Cutoff	Length of Tube ft (m)	Effective Surface Area per Tube ft <sup>2</sup> (m <sup>2</sup> )
TI	10,000	6.5 (2.0)	0.86 (0.08)
TII	20,000	5.0 (1.5)	0.65 (0.06)

Because all TI tubes received from the manufacturer were damaged in transit, tubes were cut to 6.5 feet (2.0 meters) lengths. TI tubes are manufactured 8.0 feet (2.4 meters) long with a surface area of 1.05 ft<sup>2</sup> (0.1 m<sup>2</sup>) per tube.

The operating limits of each tubular system are summarized in Table 2.

TABLE 2 - MEMBRANE OPERATING LIMITS

Membrane Designation	Maximum Temperature °F (°C)	Maximum Pressure psig (MPa)	pH Range
TI	104 (40)	150 (1.05)	2-11
TII	180 (82)	60 (0.42)	2-13

#### DESCRIPTION OF TEST SYSTEM

Figure 1 is a schematic of the test system used to evaluate the tubular membranes. A photograph of the test setup is shown in Figure 2. The feed tank's capacity was 30 gallons (114 liters). This tank initially was filled with tap water and the initial water flux of each membrane was determined. Although TI was evaluated at higher pressures (3-8 fold) than TII under the same operating conditions, its tighter membrane produced a lower initial water flux. Figure 3 compares the initial water flux of the two membranes over a range of pressures.

Blackwater was obtained from an office complex at DTNSRDC/Annapolis. This wastewater was transferred to the feed tank and processed by the membranes. The concentrates were returned to the tank and the permeates were discharged to the drain. A level of approximately 25 gallons (95 liters)

was maintained in the feed tank. Circulation rates for membrane TI, at elevated pressure, were obtained with a progressive cavity pump in series with a centrifugal pump. Membrane TII required only a centrifugal pump to provide an identical circulation rate at lower pressure.

Cooling coils maintained a constant feed tank temperature of 100° F (38° C). The feed tank was not aerated. Neither membrane received pretreatment (such as coarse screening) prior to processing blackwater. Accordingly, potential reliability and maintainability problems were eliminated. The membranes were evaluated under the most severe conditions. A vent in the tank was also used as a sample port for measuring hydrogen sulfide. Operating parameters were selected based on information supplied by the manufacturers and from previous experience evaluating the membrane systems. These parameters were:

Operating Pressure, TI	80-150 psig (0.56-1.05 MPag)
Operating Pressure, TII	5-40 psig (0.035-0.28 MPag)
Circulation Rate	5-15 gal/min (19-57 l/min)
Temperature	100°F (38° C)
pH	Unadjusted (6.2-8.4)

Temperature within the test loop, inlet and outlet pressures, circulation rates, and permeate flow rates (flux) were recorded. Feed tank and permeate samples were analyzed for total suspended solids and fecal coliform bacteria. All analyses were performed according to Standard Methods.<sup>7</sup>

A hydrogen sulfide (H<sub>2</sub>S) meter was used periodically to measure H<sub>2</sub>S build-up in the feed tank.

## RESULTS AND DISCUSSION

### FLUX PERFORMANCE

Figure 4 shows the performance of the 0.5-inch (1.2 cm) tubular UF membranes processing nonaerated raw sewage. This figure is divided into two sections, Test 1 and Test 2. The abrupt peaks (spikes) shown in the figure are due to daily start-ups after the system had been shut down overnight. Depressurization of the membranes during this time period may account for the flux recovery.

Experimental errors invalidate some of the flux data for both membranes in Test 1. The temperature in the feed tank rose to 160° F (71° C) approximately 40 hours into the test. One hour was required for the temperature to return to 100° F (38° C). The temperature excursion probably affected the membranes structure because membrane TI(A) has a maximum operating temperature of 104° F (40° C). Although membrane TII(A) has a maximum operating temperature of 180° F (82° C), the manufacturer advised against operating this membrane over 125° F (52° C) and would offer no assurance of its performance above that temperature. It appears that the temperature rise also affected this membrane, as noted by the sharp flux decline after 40 hours in Test 1, Figure 4. A new membrane, TI(B), was installed after approximately 46 hours in Test I, Figure 4. The TII(A) membrane was not replaced. A plastic turbulence promoter was observed in the inlet to TI(A) when that membrane was removed from the test loop. This had been inadvertently left in the membrane. Fibrous material had accumulated around this plastic insert and reduced the flow path. This could account for the sharp flux decline (slope -0.15) of membrane TI(A). The smaller flux decline (slope -0.05) of TI(B) indicates the plastic turbulence promoter contributed to membrane TI(A)'s flux decline.

Membrane TII(A) initially showed no adverse effects processing sewage. However, a sharp flux decline is noted for the TII(A) membrane in Test 1, Figure 4, after the temperature rise. It is noted that the flux drops below that shown for membrane TI(B). An attempt to increase flux by raising the average operating pressure to 28 psig (196 kPag) at 92 hours in Test 1, Figure 4, produced a temporary flux increase. This latter operating pressure was used for the TII(B) membrane in Test 2, Figure 4.

Two new membranes, TI(C) and TII(B), were installed in the test loop. This is designated as Test 2 in Figure 4. Approximately 10 gallons (38 liters) of septic blackwater were added to the concentrated blackwater remaining in the feed tank from Test 1. Initially, the circulation rate for both membranes was reduced to 5 gal/min (19 l/min) to determine performance at the lower circulation rate and to decrease power consumption. At this circulation rate, TII(B) showed a much sharper flux decline than TI(C), Test 2, Figure 4.

After approximately 6 hours of Test 2, (166 hours in Figure 4) the circulation rate of each tubular membrane was increased to 7.5 gal/min (28 l/min) for the remainder of the evaluation. Operating pressures and temperature were the same as those used in Test 1. The rapid flux recovery due to the increased circulation rate can be observed in Figure 4. The flux decline rate of TI(C) (slope  $-0.044$ ), at the 7.5 gal/min (28 l/min) circulation rate, is comparable to TI(B) (slope  $-0.050$ ), which was evaluated at a circulation rate of 10 gal/min (38 l/min). Flux performance curves of the TI membranes for Tests 1 and 2 are compared in Figure 5. The previously described problems with TI(A) account for the sharper flux decline of this membrane. Comparable flux decline rates of TI(B) and TI(C) are more readily observed in this figure. This similarity is interesting. The 25 percent lower circulation rate used for TI(C) does not affect this membrane's flux decline rate. This circulation rate is more desirable because of its lower energy consumption.

Figure 6 expands the results shown in Test 2, Figure 4. This figure also shows the effect of suspended solids on flux (see Suspended Solids Section). Whenever a peak appears on the curve for TI(C), a corresponding peak is observed for TII(B). Similar performance is noted in Test 1, Figure 4, for TI(A), TI(B), and TII(A) membranes. It appears that both membrane types respond similarly while processing blackwater although the TII membrane shows more abrupt changes. This may be because the TII membrane is more porous, thinner, or a combination of the two. TII(B) shows approximately a 3-fold higher flux than TI(C) throughout Test 2, Figure 6. However, only the relative flux declines of each membrane type should be compared and not the absolute flux because both membranes were evaluated under different operating pressures. Only the temperature and circulation rate were kept constant.

After approximately 85 hours of Test 2, 15 gallons (57 liters) of feed tank blackwater were replaced with an equal volume of fresh blackwater. This resulted in an increase in flux for both membranes and a decrease in feed tank suspended solids. The flux of both membranes as well as the suspended solids in the feed tank remained relatively constant through the completion of the test. Anaerobic conditions prevailed in the feed tank. Approximately 140 gallons (530 liters) of additional blackwater

was added between 85 and 160 hours. This represents more than 500 grams of suspended solids added to the feed tank. A steady-state appears to have been established, as noted by the relatively constant flux of both membranes in Figure 6.

#### MEMBRANE REJECTION OF SUSPENDED SOLIDS AND FECAL COLIFORM BACTERIA

Table 3 shows that the TI and TII type UF membranes rejected suspended solids and fecal coliform bacteria throughout Tests 1 and 2 and produced effluents that satisfied the 1980 EPA marine discharge regulations. Tests 1 and 2 refer to Figure 4. All permeates were amber in color. A faint H<sub>2</sub>S odor was detected in all samples. Although anaerobic conditions appear to produce favorable UF performance, at steady state, the amount of H<sub>2</sub>S generated when the system is not operating represents a potential but controllable hazard.

TABLE 3 - SUMMARY OF FEED TANK AND PERMEATE QUALITY

Test No.	Membrane Designation	Average Total Suspended Solids mg/l		Fecal Coliform Bacteria No. of Colonies/100 ml	
		Feed	Permeate	Feed Range	Permeate
1	TI(A),(B)	2000	14	1 x 10 <sup>4</sup> -	<10
	TII(A)		12	1.9 x 10 <sup>8</sup>	<10
2	TI(C)	3650	15	2 x 10 <sup>7</sup> -	<10
	TII(B)		15	5.4 x 10 <sup>8</sup>	<10
1980 EPA Marine Discharge Regulation		≤ 150		≤ 200	

The test system of this investigation was operated 8-10 hours per day. Hydrogen sulfide concentrations of 100-500 mg/l were produced in the feed tank overnight or over the weekends. In confined spaces or with inexperienced operators, these H<sub>2</sub>S concentrations could be extremely hazardous in terms of explosivity and toxicity. Lower and upper explosive



limits of hydrogen sulfide in air are 4.3 or 46.0 percent by volume, respectively.<sup>8</sup> A toxic threshold limit value for H<sub>2</sub>S is reported as 10 ppm (cm<sup>3</sup> vapor/m<sup>3</sup> air).<sup>9</sup> Consequently, anaerobic operation of a UF blackwater processing system for shipboard application would not be feasible unless provisions for adequate ventilation were installed. This would mean additional costs and reliability and maintainability problems.

#### PRETREATMENT AND CLEANING OPERATIONS

Prior to this study, it had been established that tubular UF membranes, smaller than 0.6 cm ID, would plug with fibrous material if water pretreatment were not provided for processing macerated blackwater.<sup>2</sup> Larger tubular systems, 1-inch (2.5 cm) ID, were shown to be capable of processing macerated blackwater without pretreatment of the water.<sup>2,3</sup> The present study now has demonstrated that 0.5 inch (1.2 cm) ID tubular UF membranes can also process macerated blackwater for extended periods (over 200 hours) without pretreatment. The smaller tubular diameter membranes provide greater surface area per system volume than the 1-inch (2.5 cm) membranes. This is most significant where space limitations are critical, particularly on a military vessel.

The membranes were not cleaned during this evaluation to determine if tubular membranes could process macerated blackwater for extended periods without requiring maintenance. Previously, Harris<sup>5</sup> showed that flux could be maintained for over 1 month without cleaning operations when aerated blackwater was processed. The present study has demonstrated that membrane flux can be maintained for more than 1 month under anaerobic conditions as well. Furthermore, under these nonaerated conditions, feed tank suspended solids can be held relatively constant.

#### PARAMETRIC STUDY

A parametric study was conducted with UF membranes TI(C) and TII(B) upon completion of Test 2, Figure 4, to determine the effect of temperature, circulation rate, and pressure on membrane flux. This study was undertaken because the membranes had attained steady-state, a condition not generally

observed for a membrane system. The additional tests consisted of processing 60 gallons (227 liters) of blackwater in approximately 50 hours. Results are shown in Figures 7-15 for TII(B) and in Figures 16-18 for TI(C).

Initially, the feed tank temperature was held constant at 100° F (38° C). The effect of pressure on membrane flux at constant circulation rate and temperature was observed. These results are shown in Figures 7-9 for TII(B) and Figure 16 for TI(C). It is noted that within the scope of the studies TII(B)'s flux is highly dependent on circulation rate at a given pressure and constant temperature. TI(C)'s flux does not exhibit this dependency. When TI(C)'s circulation rate is varied at a given pressure and constant temperature, approximately a linear relationship exists with pressure and flux. This is why TI(C)'s data is shown in a single figure. Increasing the temperature from 70°-80° F (21°-27° C) produces little flux change for TI(C) as shown in Figure 16. However, a 30-40 percent increase in flux is observed when the temperature is increased to 100° F (38° C). Figures 10-13 show a similar effect for TII(B). However, for this membrane, the effect of increasing the circulation rate at a given pressure and constant temperature results in as much as a 100 percent flux change (see Figures 10 and 13). Operating membrane TII(B) at 5 gal/min (19 l/min) results in the poorest membrane performance of all the conditions investigated (see Figures 7-10). At this low circulation rate, the membrane follows the traditional flux-pressure curve, i.e., flux increases with pressure to a maximum and then declines.

The effect of temperature on flux is shown in Figures 14 and 15 and in Figures 17 and 18 for TII(B) and TI(C), respectively. In general, flux increases with temperature at a specific pressure and circulation rate. One exception is observed in Figure 14 where the flux of TII(B) increases to a maximum and then decreases at high pressure and low circulation rate. This indicates that under these conditions, pressure has a compaction effect on TII(B)'s flux which is independent of temperature.

After each of the data points shown in Figures 7-18, operating conditions of both membranes were returned to those shown in Figure 6, where steady state had been attained. In every case, membrane flux of each membrane was equivalent to the respective steady state flux of Figure 6.

This is significant in that after an additional 50 hours of testing with 60 gallons (227 liters) of blackwater, each tubular membrane's flux has not changed from its steady state value. Such results have not been previously reported. The fact that the evaluation was conducted anaerobically may explain the steady-state condition. If the blackwater were processed by the UF membranes at a rate equivalent to anaerobic degradation in the feed tank, then the suspended solids concentration would remain constant. Consequently, all other conditions being equal, flux, which is dependent on solids concentration, should exhibit constant behavior. This was observed during the last 50 hours of Test 2.

At the conclusion of the parametric study both tubular membranes were flushed with tap water for 15 minutes. Operating conditions then were returned to the steady state conditions of Figure 6. The resulting membrane flux is shown in Table 4.

TABLE 4 - RECOVERED MEMBRANE FLUX\*  
AFTER COMPLETION OF PARAMETRIC STUDY

Tubular Membrane	Steady State Flux, gal/ft <sup>2</sup> /day (m <sup>3</sup> /m <sup>2</sup> /day)	Recovered Flux gal/ft <sup>2</sup> /day (m <sup>3</sup> /m <sup>2</sup> /day)	% Recovery of Steady State Flux
TI(C)	16 (0.64)	26 (1.0)	64
TII(B)	45 (1.8)	93 (3.7)	106

\*Measured at 100° F (38° C), 7.5 gal/min (28 l/min), 105 psig (735 kPag) for TI(C) and 28 psig (196 kPag) for TII(B).

Table 4 shows that TII(B) recovers a greater percentage of its steady state flux after tap water flushing than TII(B). No further testing was conducted.

#### REQUIREMENTS FOR PROTOTYPE SYSTEM

Based on the results of this study, requirements for a prototype system can be projected. Additional data would be required to adequately design an UF-blackwater system for marine vessel application. Although pretreatment and cleaning operations were unnecessary in the present

investigation, consideration of these requirements would be necessary for an optimally designed system. Furthermore, control of hydrogen sulfide buildup during nonprocessing periods has to be demonstrated if the UF-blackwater treatment is to be operated anaerobically. This study clearly demonstrated the advantage of anaerobic operation.

A preliminary estimate of the requirements for a marine treatment system is shown below. It is noted that the TII membrane is unavailable commercially. This membrane was specially fabricated on 0.5 inch (1.2 cm) tubular supports for this study. It is anticipated that when the TII membranes are produced commercially the \$300 cost per tube will decrease below the manufacturer's cost for fabricating its 1-inch (2.5 cm) tubular membranes. This assumption is based on the TII supports being smaller and requiring less membrane material per tube than the 1-inch membranes. The larger diameter membranes currently cost \$80 per tube with a replacement price of \$50 per tube upon return of the original tubular membrane. TI's manufacturer currently charges \$6 per tube with no replacement offered.

The following assumptions are made for projecting the preliminary requirements of a marine UF-blackwater system:

1. U.S. Army vessel with a complement of 20.
2. Blackwater Generation Rate: 15 gal (57 liters)/capita per day or 300 gallons (1.1 m<sup>3</sup>) per day.
3. System processes blackwater 24 hours per day.
4. Average membrane flux based on Test 2 of this study.
5. Commercially produced TII membranes would provide same results as TII membrane used in this study.
6. Tubular membranes process blackwater in parallel (without specifying module size).
7. Length of TI membrane is 8 feet (2.4 meters). (Not the 6.5 feet (2.0 meters) used in this study.)
8. Circulation Rate: 7.5 gal/min/tube (28 l/min/tube).
9. Average Operating Pressure: TI - 105 psig (735 kPag)  
TII - 28 psig (196 kPag)
10. Operating Temperature: 100° F (38° C)
11. Marine Vessel Power Cost: \$0.08/kW-hr.

Using these assumptions, Table 5 shows the projected requirements for processing 300 gal/day (1.1 m<sup>3</sup>/day) of blackwater.

TABLE 5 - ESTIMATED<sup>1</sup> REQUIREMENTS FOR MARINE VESSEL  
BLACKWATER ULTRAFILTRATION SYSTEM

Tubular Membrane Type	Average Flux gal/ft <sup>2</sup> /day (m <sup>3</sup> /m <sup>2</sup> /day)	Surface Area ft <sup>2</sup> (m <sup>2</sup> )	No. Tubes Required	Initial Tube Cost, \$	Replacement <sup>2</sup> Cost, \$/day	Power Consumption	
						kW	Cost \$/day
TI	16 (0.64)	18.8 (1.7)	18	96 <sup>(3)</sup>	0.13 <sup>(3)</sup>	26.4	0.50
TII	45 (1.8)	6.7 (0.6)	11	880 <sup>(4)</sup>	0.75 <sup>(5)</sup>	1.6	0.03

<sup>1</sup> Assuming that operation and maintenance costs are the same for TI and TII.

<sup>2</sup> Assuming 2-year life expectancy.

<sup>3</sup> Based on new or replacement TI cost of \$6 per tube.

<sup>4</sup> Assuming \$80 per tube for TII which is current cost of new 1-inch tube.

<sup>5</sup> Assuming \$50 per tube which is current replacement price for 1-inch tube.

The membrane costs in Table 5 are preliminary figures and are shown as a relative indication of the requirements for both membranes. More accurate costs for TII cannot be made at this time. Although the power requirements of this membrane are significantly lower than TI, the commercial price of the membrane will ultimately determine the tradeoff between the two membranes.

#### SUMMARY OF FINDINGS AND CONCLUSIONS

1. Half-inch (1.2 cm) UF membranes can process macerated blackwater, producing an effluent which satisfies the 1980 EPA marine discharge regulations for suspended solids and fecal coliform bacteria.

2. Pretreatment is not required when half-inch (1.2 cm) tubular UF membranes process macerated blackwater. However, a coarse screen would be recommended for prolonged operations to protect the membrane from abrasive materials.

3. Depressurization of half-inch (1.2 cm) tubular UF membranes overnight, through system shutdown, is sufficient to maintain membrane flux for extended periods without a cleaning operation.

4. Steady-state membrane performance may be attained with anaerobic operation.

5. Unless  $H_2S$  production can be safely controlled during anaerobic UF-processing of blackwater, marine application of this system will not be feasible. The alternative would be aerobic processing, which has been demonstrated with 1-inch (2.5 cm) tubular UF membranes.

6. Low flux (tight) UF membranes consume greater power and produce less effluent (permeate) than higher flux (porous) UF membranes.

7. Tight UF membranes are less sensitive (show less effluent rate variations) to changes in circulation rate compared with more porous UF membranes, which are highly sensitive (show large variations in effluent rate).

8. Both tight and porous tubular UF membranes respond similarly when processing macerated blackwater, i.e., when one exhibits increased flux, the other shows the same behavior. The converse is also true.

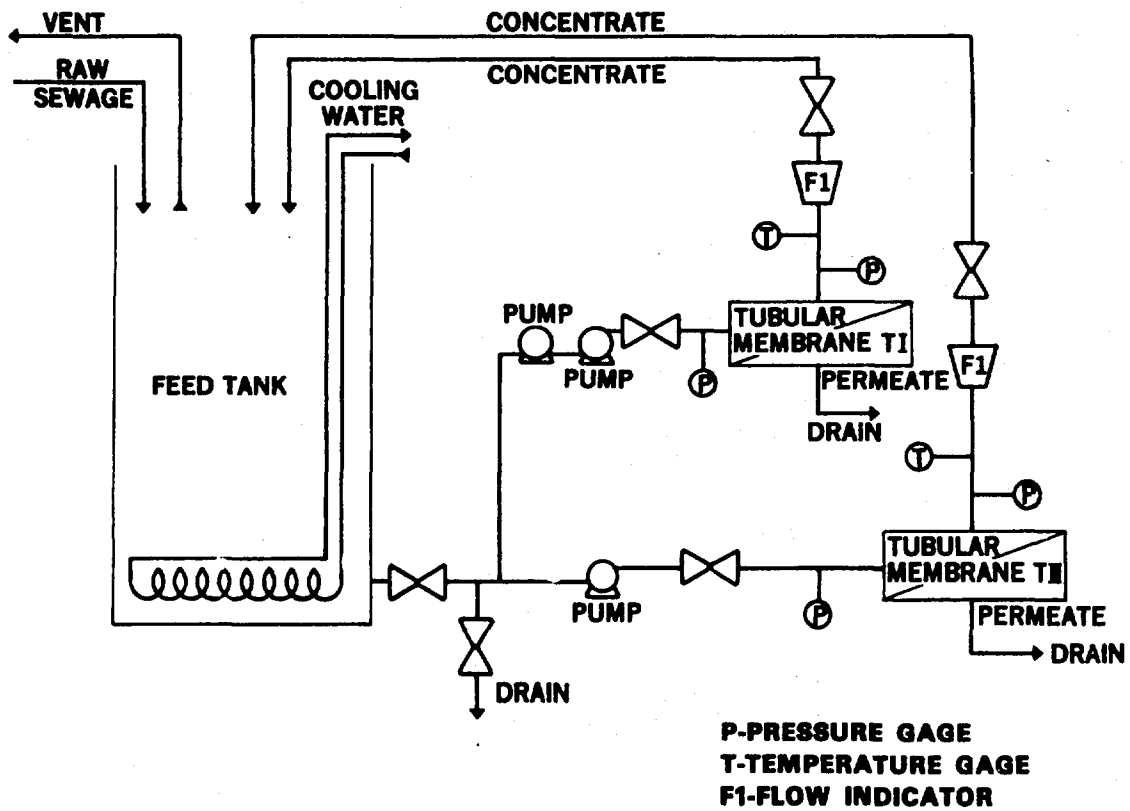

**FIGURE 1 UTRAFILTRATION TEST SYSTEM SCHEMATIC**

Figure 1 - Ultrafiltration Test System Schematic

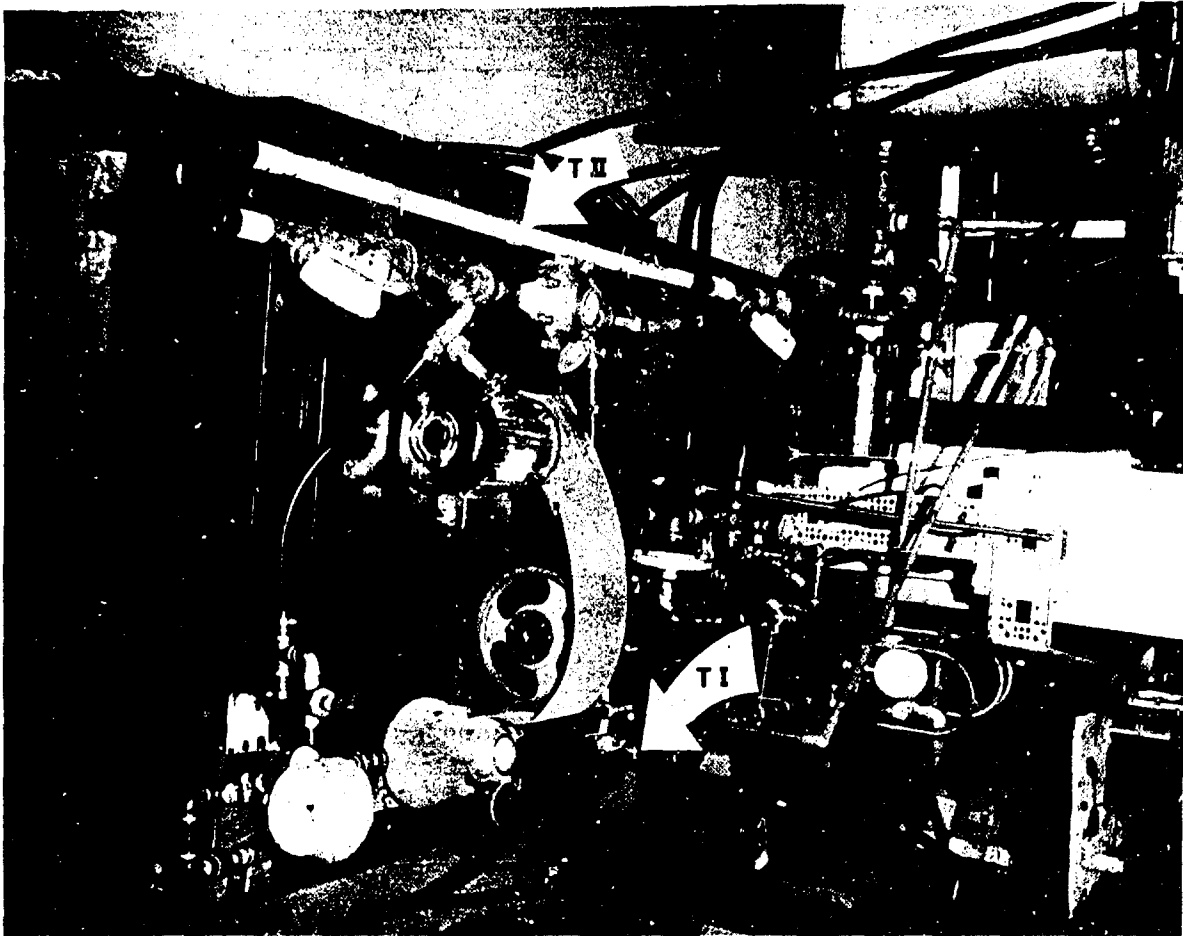

Figure 2 - Test Setup

1  
1  
1



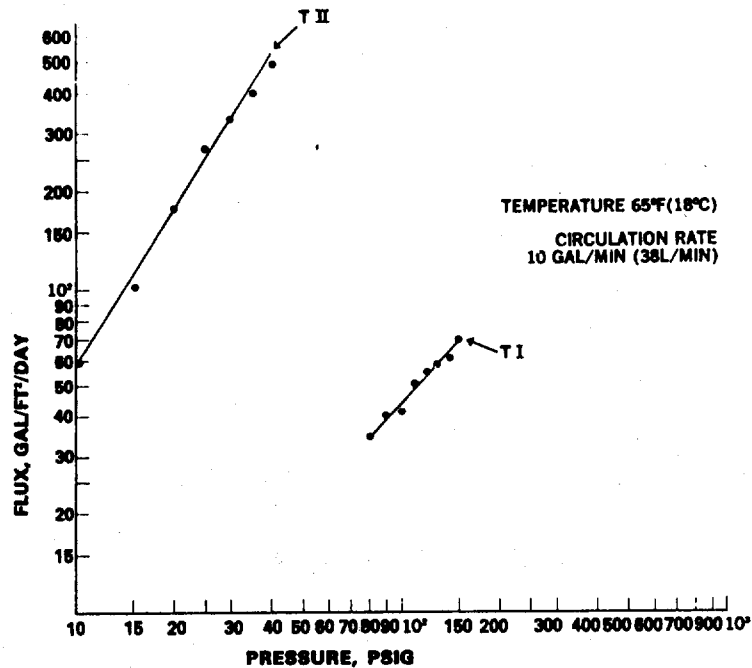

Figure 3 - Effect of Pressure on Initial Water Flux

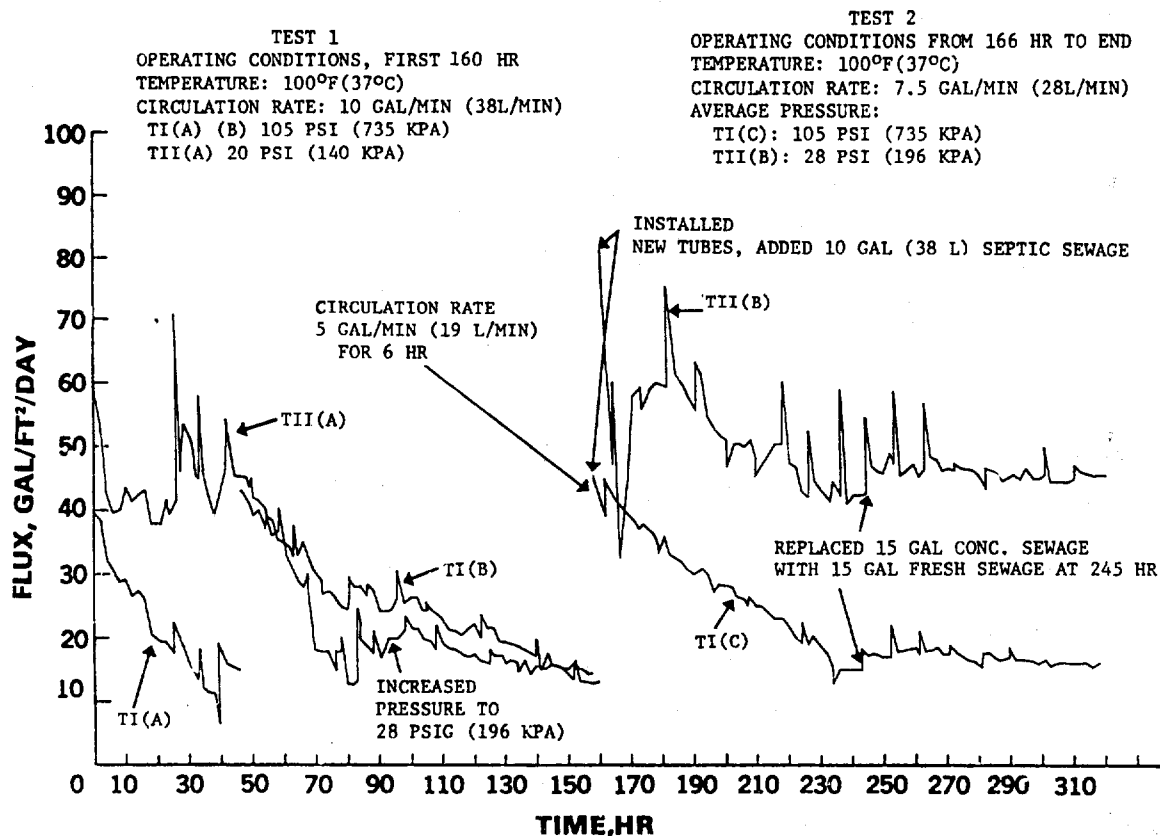

Figure 4 - Flux Vs Time Performance of Half-Inch Tubular Ultrafiltration Membranes Processing Nonaerated Raw Sewage

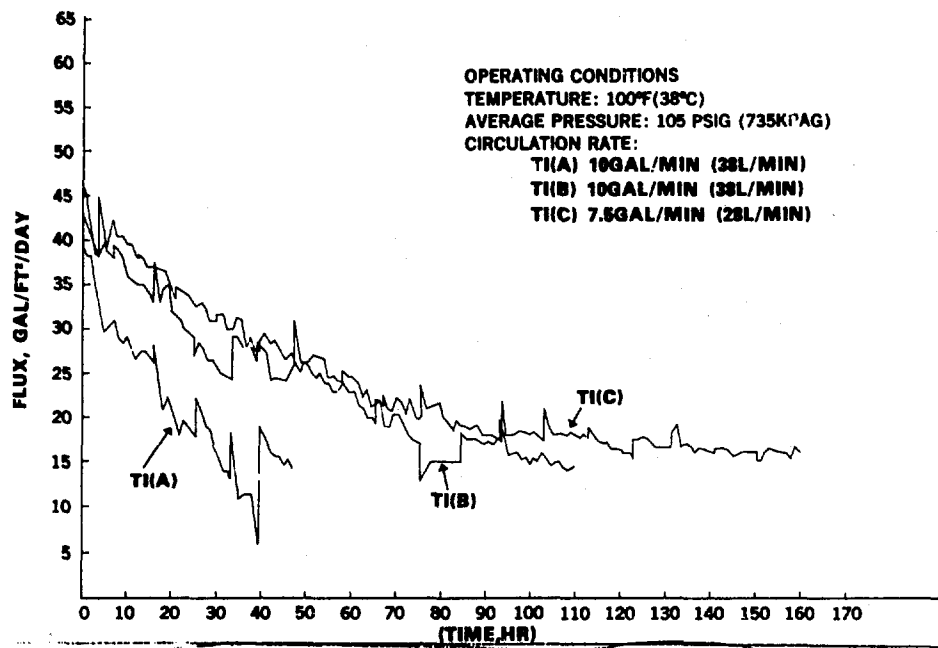

Figure 5 - Comparison of Tubular (TI) Membranes Processing Nonaerated Raw Sewage

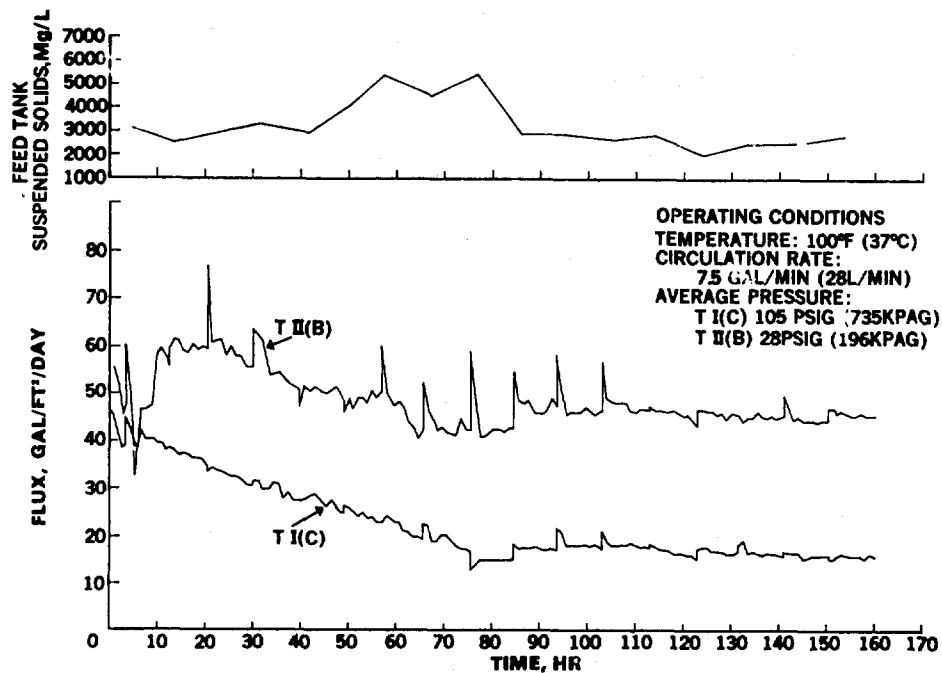

Figure 6 - Flux Performance of Tubular Membranes TI(C), TII(B), and the Effect of Suspended Solids, Test 2

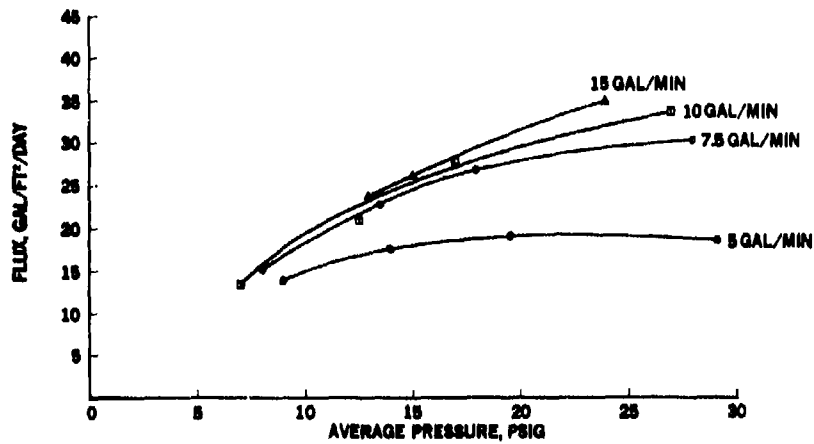

Figure 7 - Effect of Pressure on Flux of TII(B)  
at Constant Circulation Rate and 70° F (21° C)

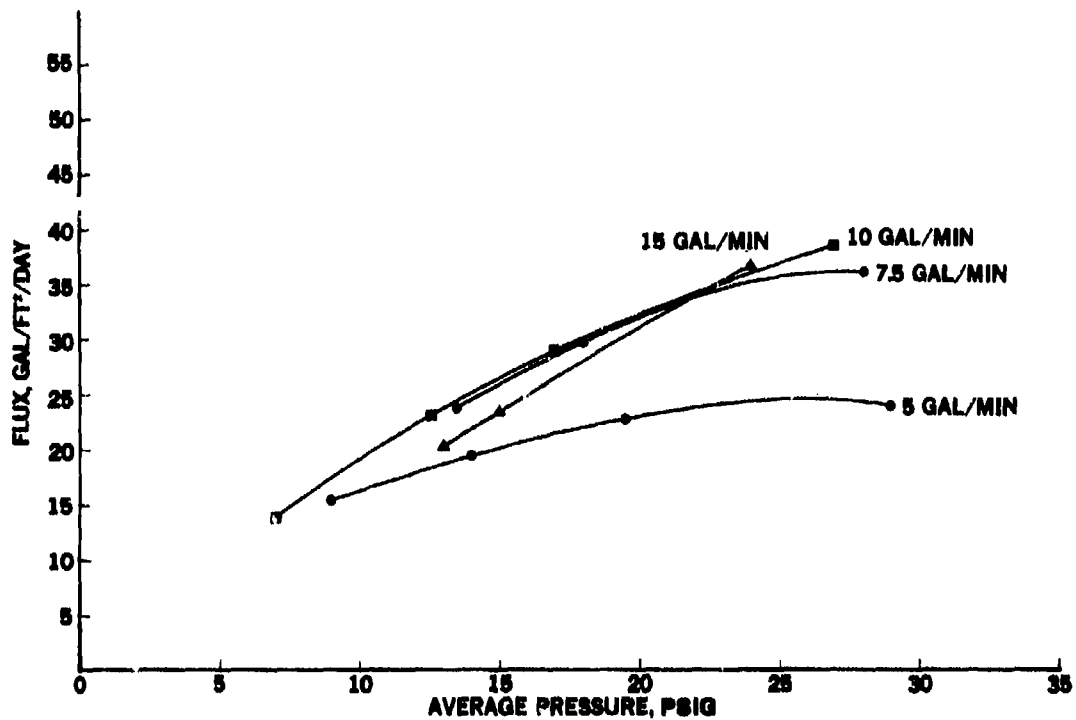

Figure 8 - Effect of Pressure on Flux of TII(B)  
at Constant Circulation Rate and 80° F (27° C)

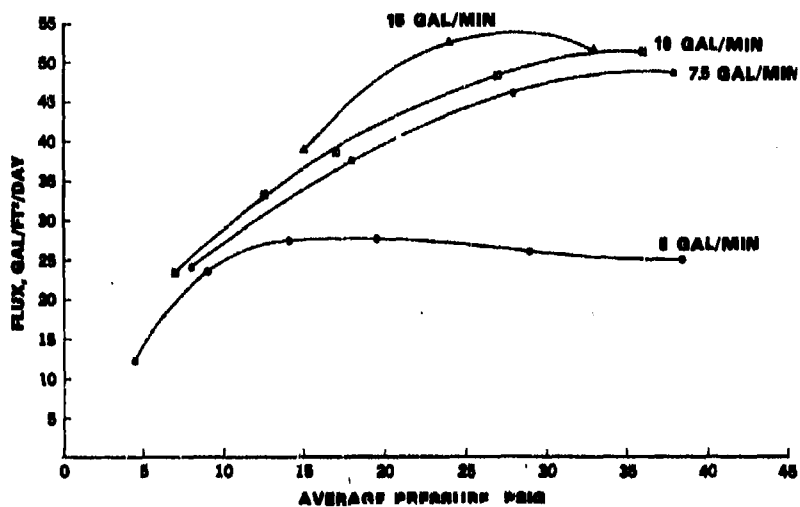

Figure 9 - Effect of Pressure on Flux of TII(B)  
at Constant Circulation and Rate of 100° F (38° C)

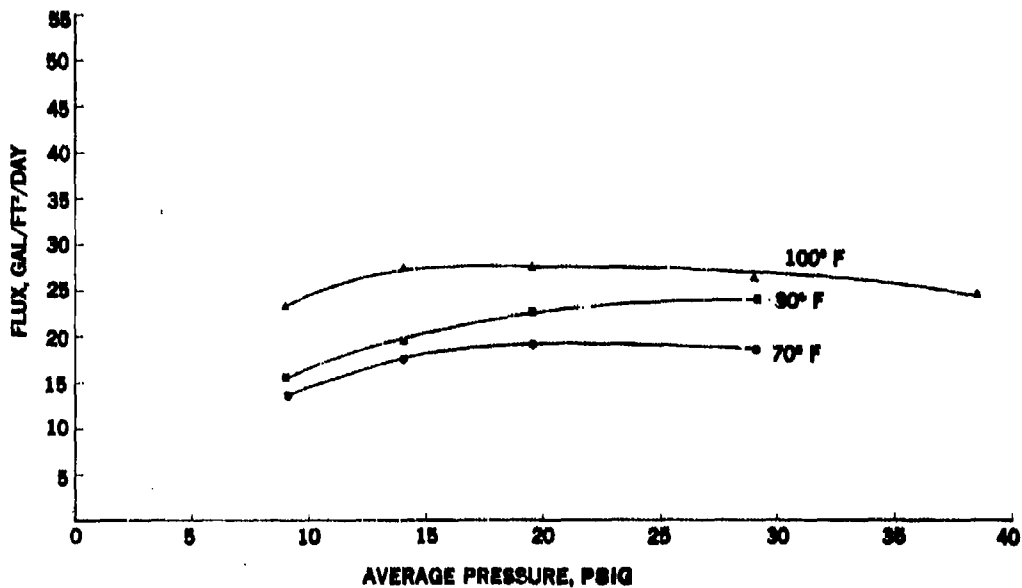

Figure 10 - Effect of Pressure on Flux of TII(B)  
at Constant Temperature and 5 Gal/Min (19 L/Min)

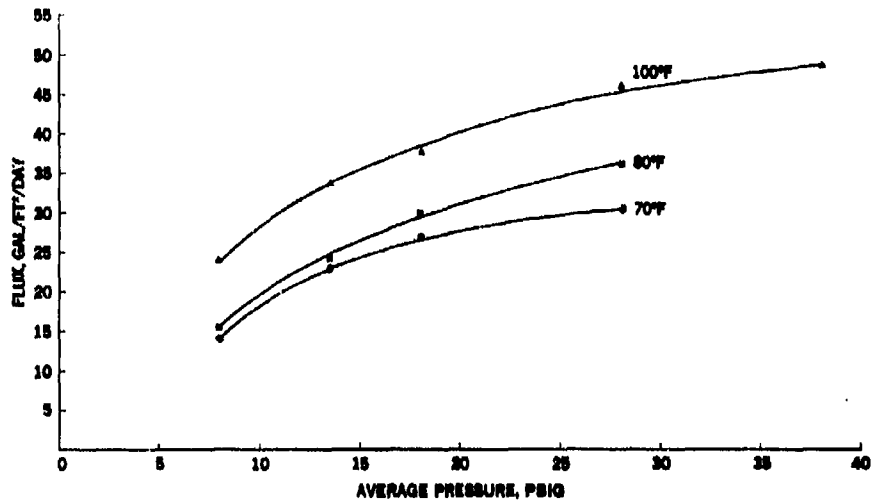

Figure 11 - Effect of Pressure on Flux of TII(B)  
at Constant Temperature and 7.5 Gal/Min (28 L/Min)

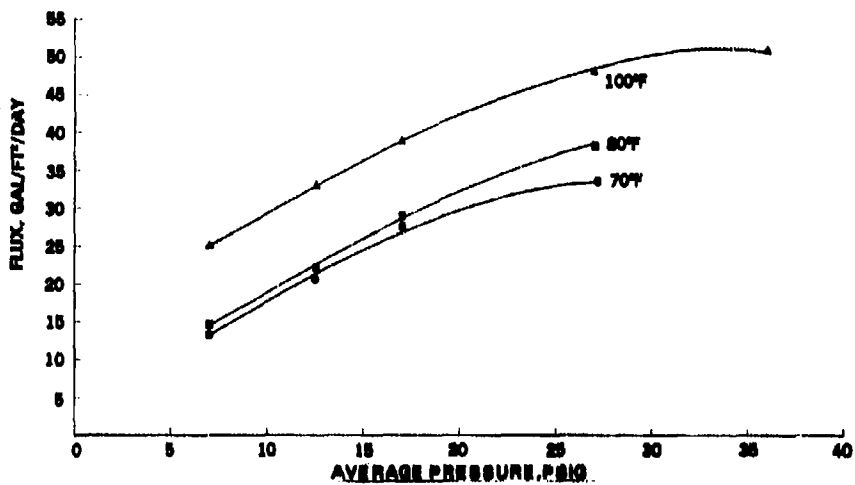

Figure 12 - Effect of Pressure on Flux of TII(B)  
at Constant Temperature and 10 Gal/Min (38 L/Min)

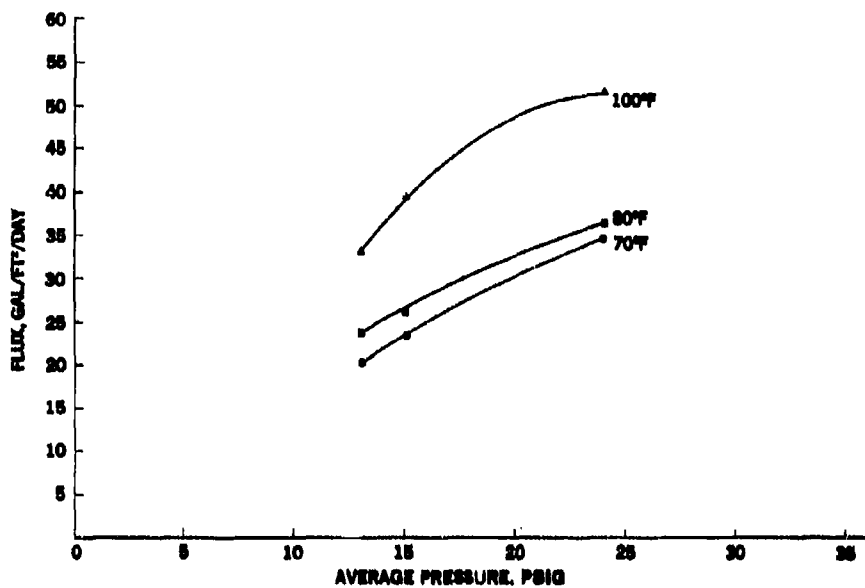

Figure 13 - Effect of Pressure on Flux of TII(B) at Constant Temperature and 15 Gal/Min (57 L/Min)

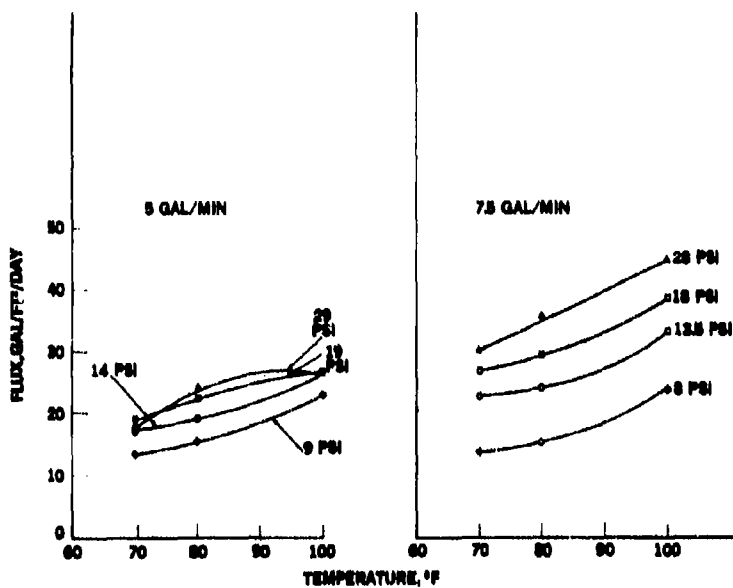

Figure 14 - Effect of Temperature on Flux of TII(B) at Constant Pressure and 5 Gal/Min, 7.5 Gal/Min

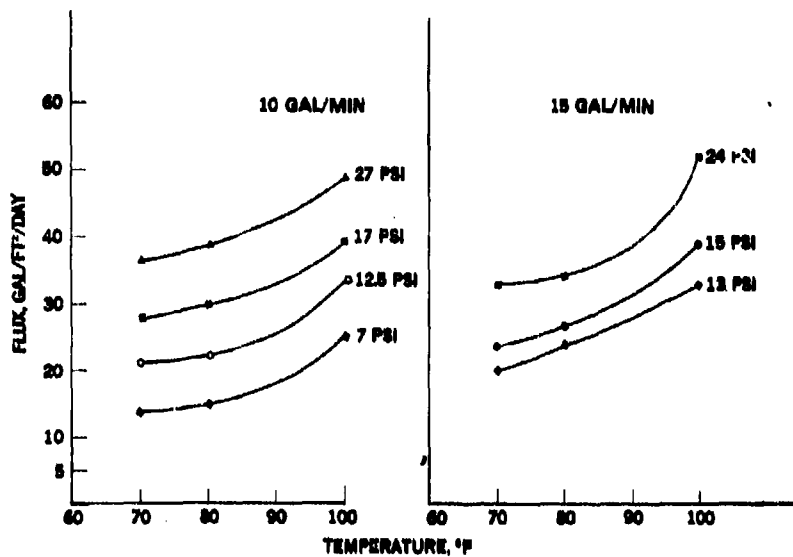

Figure 15 - Effect of Temperature on Flux of TII(B) at Constant Pressure and 10 Gal/Min, 15 Gal/Min

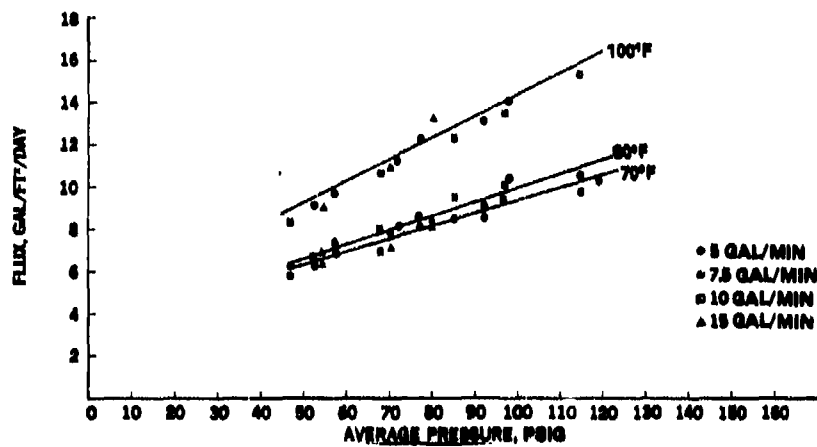

Figure 16 - Effect of Pressure on Flux of TI(C) at Constant Circulation Rate and Temperature

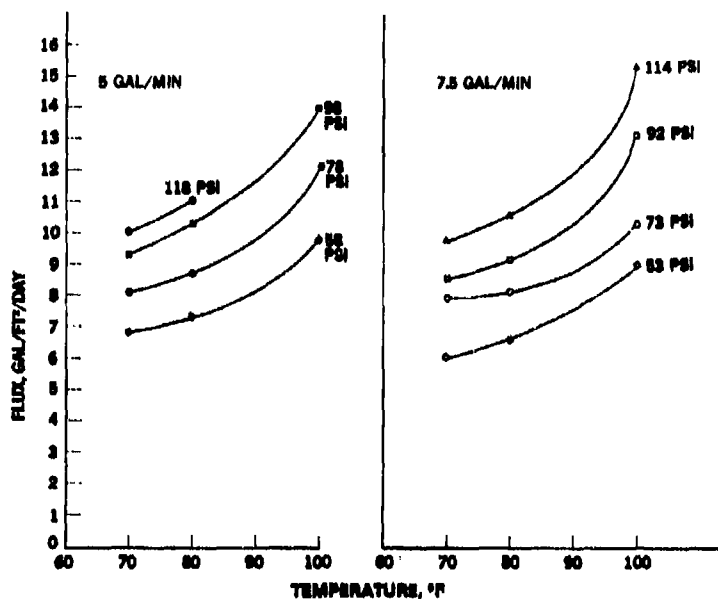

Figure 17 - Effect of Temperature on Flux of TI(C) at Constant Pressure and Circulation Rate

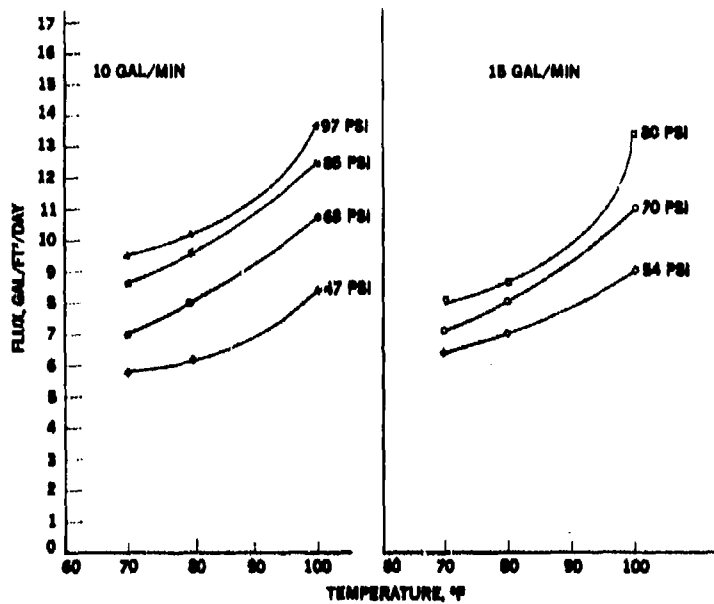

Figure 18 - Effect of Temperature on Flux of TI(C) at Constant Pressure and Circulation Rate



#### REFERENCES

1. Federal Register, Vol. 41, No. 71, p. 15324 (12 Apr 1976)
2. Harris, L. R. and C. M. Adema, "Processing Raw Sewage with Ultrafiltration," DTNSRDC Rept MAT-77-79 (Apr 1977)
3. Harris, L. R., et al, "Ultrafiltration of Black and Grey Wastewater," presented at the Intersociety Conference on Environmental Systems, San Francisco, California (11-14 July 1977)
4. Bailey, J. R., "Phase I Final Report, Shipboard Sewage Treatment System," Navy Contract N00029-71-G5329, Rept AD 733,082 (Nov 1971)
5. Harris, L. R., "Ultrafiltration of Activated Sludge: A Comparison of Three Membrane Configurations," DTNSRDC Rept SME-78-1
6. Hoover, P. R., et al, Walden Div. of Abcor, Inc., "Evaluation of Ultrafiltration and Disinfection for Treatment of Blackwater," under U.S. Army Contract DAAG53-76-0083 (Mar 1977)
7. Standard Methods for Examination of Water and Waste Water, 14th Ed., American Public Health Association, Washington, D. C. (1977)
8. The Merck Index, 8th Ed., Merck and Co., Rahway, N.J., p. 546 (undated)
9. Ariens, E. J., et al, Introduction to General Toxicology, Academic Press, New York (1976)

INITIAL DISTRIBUTION

Copies		CENTER DISTRIBUTION	
		Copies	Code
2	NAVMAT (MAT 0341)	1	28
5	US Army MERADCOM	1	280
	DRX FB-GS	1	2802
	Ft. Belvoir, VA 22060	4	286
	Attn: Mr. G. Eskelund	5	2861
		1	2863
1	USAMBRDL	1	2864
	SGRD-UBG	1	5222
	LTC L. Reuter	2	5231
	Ft. Detrick		
	Frederick, MD 21701		
6	NAVSEA		
	1 SEA 03C		
	2 SEA 0331F		
	1 SEA 04F		
	2 SEA 09G32		
1	National Bureau of Standards		
	Building Services Section		
	Building 226, Rm B-306		
	Wash., D.C. 20234		
	Attn: Ms. D. Brown		
1	Dept of Interior		
	Office of Water R&T		
	Wash., D.C. 20240		
	Attn: Dr. K. C. Channabasappa		
1	Environmental Protection Agency		
	Industrial Pollution Control Div.		
	Organic Chemicals and Products Branch		
	5555 Ridge Avenue		
	Cincinnati, OH 45268		
	Attn: Mr. R. Turner		
1	CEL		
12	DDC		

**DTNSRDC ISSUES THREE TYPES OF REPORTS**

1. DTNSRDC REPORTS, A FORMAL SERIES, CONTAIN INFORMATION OF PERMANENT TECHNICAL VALUE. THEY CARRY A CONSECUTIVE NUMERICAL IDENTIFICATION REGARDLESS OF THEIR CLASSIFICATION OR THE ORIGINATING DEPARTMENT.

2. DEPARTMENTAL REPORTS, A SEMIFORMAL SERIES, CONTAIN INFORMATION OF A PRELIMINARY, TEMPORARY, OR PROPRIETARY NATURE OR OF LIMITED INTEREST OR SIGNIFICANCE. THEY CARRY A DEPARTMENTAL ALPHANUMERICAL IDENTIFICATION.

3. TECHNICAL MEMORANDA, AN INFORMAL SERIES, CONTAIN TECHNICAL DOCUMENTATION OF LIMITED USE AND INTEREST. THEY ARE PRIMARILY WORKING PAPERS INTENDED FOR INTERNAL USE. THEY CARRY AN IDENTIFYING NUMBER WHICH INDICATES THEIR TYPE AND THE NUMERICAL CODE OF THE ORIGINATING DEPARTMENT. ANY DISTRIBUTION OUTSIDE DTNSRDC MUST BE APPROVED BY THE HEAD OF THE ORIGINATING DEPARTMENT ON A CASE-BY-CASE BASIS.