

2000

7744

MOST Project - 4

ADA 071350

BS

# APPLIED RESEARCH LABORATORIES

# LEVEL

## THE UNIVERSITY OF TEXAS AT AUSTIN

8 May 1974

Copy No. 7

### TECHNICAL AND MATERIAL SUPPORT FOR THE AN/FQM-10(V) SONAR TEST SET AND NAVAL SHIPYARD TRANSDUCER REPAIR FACILITY TEST SITES

Quarterly Progress Report No. 7 under Contract N00126-72-C-1748  
27 December 1973 - 26 March 1974

James E. Stockton  
Gary G. Warren

NAVAL SHIP ENGINEERING CENTER  
Contract N00126-72-C-1748  
Proj. Ser. No. N65539-2137-0045

DDC FILE COPY.

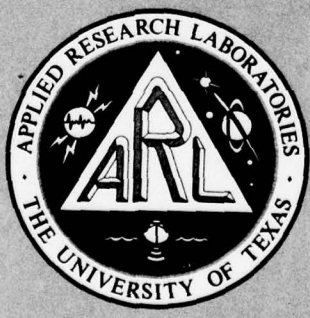

DDC  
RECEIVED  
JUL 19 1979  
A

48-15

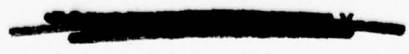

DISTRIBUTION STATEMENT E  
Approved for public release;  
Distribution Unlimited

11

8 May 1974

12 33p.

6

**TECHNICAL AND MATERIAL SUPPORT FOR THE AN/FQM-10(V) SONAR TEST SET AND NAVAL SHIPYARD TRANSDUCER REPAIR FACILITY TEST SITES.**

Quarterly Progress Report, No. 7, under Contract N00126-72-C-1748  
27 December 1973 - 26 March 1974

9

6006 094L

10

James E. Stockton  
Gary G. Warren

15

NAVAL SHIP ENGINEERING CENTER  
Contract N00126-72-C-1748  
Proj. Ser. No. N65539-2137-0045

Accession For	
NTIS GRA&I	<input checked="" type="checkbox"/>
DDC TAB	<input type="checkbox"/>
Unannounced	<input type="checkbox"/>
Justification	<i>File on file</i>
By	
Distribution/	
Availability Codes	
Dist.	Avail and/or special
<b>A</b>	

APPLIED RESEARCH LABORATORIES  
THE UNIVERSITY OF TEXAS AT AUSTIN  
AUSTIN, TEXAS 78712

404 434

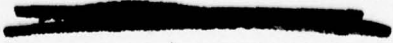

LB

ABSTRACT

ARL repaired and calibrated a PVIM from NAVSHIPYDPTSMH and received a new PVIM from Scientific-Atlanta. ARL personnel have produced an addendum to the PVIM instruction manual and have traveled to Atlanta, Georgia, to discuss with Scientific-Atlanta personnel the reprinting of the operators' manuals. ARL personnel have attended STEP Working Group Meeting No. 15 and have traveled to NAVSHIPYDPTSMH to repair units of the AN/FQM-10(V) test sets. ARL continues to provide technical and material support for the AN/FQM-10(V) sets and the TRF test sites.

TABLE OF CONTENTS

	<u>Page</u>
ABSTRACT	iii
I. INTRODUCTION	1
II. SUMMARY OF PROGRESS	3
III. DETAILS OF PROGRESS	5
A. New PVIM from Scientific-Atlanta	5
B. Repair and Calibration of NAVSHIPYDPTSMH PVIM	6
C. Visit to Scientific-Atlanta, Incorporated, in Atlanta, Georgia	8
D. Addendum to PVIM Instruction Manual	9
E. STEP Working Group Meeting No. 15 at ARL from 12 through 15 February 1974	9
F. Repair of Units of the AN/FQM-10(V) at NAVSHIPYDPTSMH	10
1. Aboard the YFNX-21 sonar test barge	10
2. Aboard the YFNX-15 sonar test barge	11
APPENDIX	13
ADDENDUM TO INSTRUCTION MANUAL FOR MODEL 1170 PULSE VECTOR IMMITTANCE METER	13
I. SPECIFICATIONS OF MODEL BC 801 3 MHz POLARITY AND CONTROL MODULE	15
A. General	15
B. Specifications	15
II. SPECIFICATIONS OF MODEL BC 803 3 MHz BIDIRECTIONAL DECADE COUNTER MODULE	17
A. General	17
B. Specifications	17

## I. INTRODUCTION

Applied Research Laboratories (ARL) was awarded Contract N00126-72-C-1748, effective 27 June 1972. The contract was modified, effective 24 May 1973, by modification P-00003. Work under this contract and its modification is concerned with providing technical and material support for the seven AN/FQM-10(V) sonar test sets located at the three Naval shipyards that have transducer repair facilities (TRFs); NAVSHIPYDPTSMH (two sets), NAVSHIPYDMARE (two sets), NAVSHIPYDPEARL (two sets), and ARL (pilot system).

This quarterly progress report will contain, in Chapter II, a summary of progress during the quarter. Chapter III will give a detailed description of the progress. The addendum to the instruction manual for the model 1170 pulse vector immittance meter is included as an appendix.

## II. SUMMARY OF PROGRESS

ARL's progress during the quarter can be summarized as follows.

1. ARL received a new PVIM from Scientific-Atlanta to be used as a spare.
2. ARL repaired and calibrated the PVIM from NAVSHIPYDPTSMH.
3. ARL personnel visited Scientific-Atlanta and discussed the reprinting of the AN/FQM-10(V) operators' manuals.
4. ARL produced an addendum to the PVIM instruction manual; the addendum describes the digital readout display modules.
5. ARL personnel attended STEP Working Group Meeting No. 15, held at ARL in Austin, Texas, from 12 to 15 February 1974.
6. ARL personnel traveled to NAVSHIPYDPTSMH to repair units of the AN/FQM-10(V) test set.

### III. DETAILS OF PROGRESS

#### A. New PVIM from Scientific-Atlanta

On 4 January 1974, ARL received a new Pulse Vector Immittance Meter (PVIM), unit No. 27, from Scientific-Atlanta, Incorporated, to be used as a spare. The purchase of this unit was mentioned in Quarterly Progress Report No. 4 under Contract N00126-72-C-1748.

The PVIM consists of three units.

1. Main Frame Model No. 1170-1-0, Ser 15
2. Range Selector Model No. 1170-2-0, Ser 15
3. Sampler Model No. 1170-3-0, Ser 20

Mr. Gary G. Warren of ARL examined the new PVIM for proper operation. The following changes were made before the PVIM was ready for use.

#### Main Frame 1170-1-0 Ser 15

A BNC connector was installed on the rear panel for a sample pulse test point.

#### Sampler 1170-3-0 Ser 20

The signal into the sampler current amplifier line driver was distorted. The gain of the line driver had been raised to achieve proper output amplitude. The high and low sides of the signal into the line driver had been reversed at the factory.

The leads were switched to their proper places. The output level was then greater in amplitude and was undistorted. The gain resistor was changed to its proper value and the line driver waveforms were good at both input and output.

This change of high and low sides of the line driver input resulted in a 180° error in the phase readout in the main frame.

The two current sampling coils were removed from the sampler and turned 180° so that the current would flow in the proper direction through the coils. The main frame then had the proper readout.

The new PVIM was sent to Portsmouth Naval Shipyard to be used there while the PVIM aboard the YFNX-15 sonar test barge was being repaired and calibrated at ARL.

B. Repair and Calibration of NAVSHIPYDPTSMH PVIM

The Pulse Vector Immittance Meter (PVIM), unit No. 27, aboard the YFNX-15 sonar test barge was sent to ARL to be repaired and calibrated.

The PVIM consists of three units.

1. Main Frame Model 1170-1-0, Ser 2
2. Range Selector Model 1170-2-0, Ser 4
3. Sampler Model 1170-3-0, Ser 4

Mr. Gary Warren of ARL received the PVIM and performed the following maintenance tasks on the three units.

Main Frame 1170-1-0 Ser 2

1. Removed all PC boards from the main frame.
2. Cleaned all parts in freon bath.
3. Resoldered broken wire to sample pulse test point.
4. Installed new ON/OFF power switch.
5. Sprayed all switches with contact cleaner.
6. Lubricated all mechanical parts.
7. Polished all PC board contacts.



8. Installed missing stand-off for capacitor C8 on PC board A7.
9. Replaced charred resistor R12 of PC board A2 ( $\pm 15$  V supply).
10. Replaced bad transistor Q6 and bad integrated circuit G6 on PC board A55.
11. Repaired bad solder joint where wire connects to connector XA19 pin 17.

Range Selector 1170-2-0 Ser 4

1. Disassembled unit.
2. Cleaned all parts in freon bath.
3. Polished all PC board contacts.
4. Sprayed all switches with contact cleaner.
5. Lubricated all mechanical parts.
6. Resoldered broken wire at pin A on connector for PC board A4.
7. Reassembled unit.
8. Checked all diodes in switching network.
9. Exchanged wires on switch S2 in order to switch through the higher voltages first when in operation.

Sampler 1170-3-0 Ser 4

1. Disassembled unit.
2. Cleaned all parts in freon bath.
3. Polished all PC board contacts.
4. Reassembled unit.
5. Replaced relay K6.
6. Replaced transistor Q6 in the current amplifier line driver.
7. Replaced resistors R4, R5, R6, R7, R8, and R9 with other values in order to achieve the proper relation between X1, X2, and X5 on the range selector.

The three units of the PVIM were interconnected and calibrated and then shipped back to NAVSHIPYDPTSMH.

C. Visit to Scientific-Atlanta, Incorporated, in Atlanta, Georgia

Mr. Jim Stockton, Mr. Gary Warren, and Mr. H. A. Hamblin of ARL were in Atlanta, Georgia, from 28 through 30 January 1974. They met with Mr. Jim Cox, Mr. Joe Pape, and Mr. Johnny Floyd of Scientific-Atlanta to discuss the reprinting of the AN/FQM-10(V) operators' manuals.

The overall layout of the manuals was considered first. Included in this layout was the lack of parallelism between lists of switch settings, detailed instructions in some sections, the lack of detailed instructions in other sections, the inconsistency of names of individual units of the test set, and also typographical errors and nearly incomprehensible sentences.

Several technical problems in the operators' manuals were also discussed. At several places in the manuals, the procedure required that the operator advance the gain of the drive signal to twice its test level with the projector attached to the output. At other places in the manuals the procedure required that the operator place the initial setting of the E I normalizer, unit No. 13, servo motor indicator, at its maximum gain, so that when the E I normalizer motor was switched ON the normalizing action would attenuate to the desired level from its maximum output.

Such questionable procedures as the two examples given were judged to be oversights in the original printing.

Another topic reviewed at the meeting was the instruction manual for the Pulse Vector Immittance Meter (PVIM), unit No. 27. Corrections to the original text and additional aids for troubleshooting, generated by ARL from previous PVIM alignments, were discussed.

It was concluded that since Scientific-Atlanta did not have a group assigned specifically to edit such material, ARL would accept the responsibility of the changes, additions, and editing of the manuals. When ARL is satisfied with the manuals, they will be sent to Scientific-Atlanta for printing.

D. Addendum to PVIM Instruction Manual

Scientific-Atlanta's Pulse Vector Immittance Meter (PVIM), unit No. 27, instruction manual contained no information on the unit's digital readout display.

Information has been gathered for an addendum to the PVIM instruction manual, as stated in the Quarterly Progress Report No. 3 under Contract N00126-72-C-1748.

Mr. Gary Warren of ARL organized the material and ARL's Technical Reports Office edited and printed the addendum, which is included as the appendix of this report.

E. STEP Working Group Meeting No. 15 at ARL from 12 through 15 February 1974

Mr. James E. Stockton of ARL attended STEP Working Group Meeting No. 15 held at ARL from 12 through 15 February 1974. A brief progress report was given which covered the technical and material support of the AN/FQM-10(V) and the TRF test sites since the last STEP Working Group meeting. A list of attendees and a complete list of the topics discussed at the meeting can be found in Meeting Report NAVSHIPS Sonar Project Technical Support Program (STEP) Working Group Meeting No. 15, to be published.

F. Repair of Units of the AN/FQM-10(V) at NAVSHIPYDPTSMH

Mr. E. J. Comeau of NAVSHIPYDPTSMH contacted Mr. Gary Warren of ARL to inform him that the units of the AN/FQM-10(V) sonar test set aboard the YFNX-21 sonar test barge were cleaned and reinstalled in the console.

Mr. Comeau requested that Mr. Warren be available at Portsmouth for repair work when the ac power was applied to the test set.

During Mr. Warren's visit to NAVSHIPYDPTSMH, from 4 through 22 February 1974, the following repairs to the set were made.

1. Aboard the YFNX-21 sonar test barge
  - a. Broken sample cables on the Pulse Vector Immittance Meter (PVIM), unit No. 27, were repaired and a missing ground cable was added. After some minor adjustments were made in the sampling unit, unit No. 30, and the range selector, unit No. 29, the PVIM operated properly.
  - b. The cables attached to the rear of the Sampling Digital Voltmeter (SDVM), unit No. 74, were separated from other cables, bundled, and labeled. All PC board contacts were polished and the switches were sprayed with contact cleaner. Relay K4 was replaced and the SDVM was back in operation.
  - c. Broken sample cables on the E I normalizer, unit No. 13, were repaired. Capacitor C73 on the servo amplifier board was replaced. The unit was aligned and returned to operation.

- d. The spare E I normalizer, unit No. 13, was aligned after replacing component  $V_1$ . The unit then operated properly.
- e. The PEN GAIN and TACH were adjusted on the polar recorder, unit No. 17, and the recorder traced properly.
- f. The PEN GAIN and TACH and the CHART DRIVE GAIN and TACH were adjusted on the rectangular recorder, unit No. 24, and the unit was returned to operation.
- g. The frequency tracking servo, unit No. 4, operated properly after the unit was aligned.
- h. The x-axis pen drive cable was restrung on the X-Y recorder, unit No. 48, and the unit was returned to operation.
- i. The line follower, unit No. 49, was adjusted so that it would operate properly.
- j. Preamplifier No. 1, unit No. 5, on the transmit side of the test set was calibrated.
- k. Differential preamplifier, unit No. 6, on the receive side of the console was calibrated.

2. Aboard the YFNX-15 sonar test barge

- a. Transistor Q10 was replaced in the polar recorder's detector, unit No. 19, and the unit was returned to operation.

- b. All PC boards were removed from the SDVM, unit No. 74, and the contacts were polished. Relay K5 on the attenuator board was replaced, and the SDVM operated properly.
- c. The PEN GAIN and TACH were adjusted on the polar recorder, unit No. 17, which returned the unit to operation.
- d. The PEN GAIN and TACH and the CHART DRIVE GAIN and TACH were adjusted on the rectangular recorder, unit No. 24. The unit then operated properly.
- e. The frequency tracking servo, unit No. 4, was aligned to give the proper output on each range.
- f. The differential preamplifier, unit No. 6, on the receive side was calibrated for proper operation.
- g. A broken wire inside the E I normalizer, unit No. 13, was resoldered. The unit was aligned and returned to operation.
- h. The new PVIM, unit No. 27, from ARL was installed and checked for proper readouts.
- i. Six console cooling fans were installed in the console.

APPENDIX

ADDENDUM TO INSTRUCTION MANUAL  
FOR MODEL 1170 PULSE VECTOR IMMITTANCE METER

The instruction manual for the model 1170 PVIM contains no description of the digital readout display portion of the Pulse Vector Immittance Meter (PVIM), depicted in Fig. 1.

In an effort to assist troubleshooting of this unit, Applied Research Laboratories, The University of Texas at Austin, has obtained all available related information from Dob Corporation, the manufacturer of the display, and has compiled this addendum to the instruction manual.

Edward F. Walsh, president of Dob Corporation, has offered to provide test equipment and replacement parts in addition to repair services for the modules. 



The digital readout display consists of eight modules; six of the modules are model BC 803, which are 3 MHz bidirectional decoder counter modules, and the remaining two are model BC 801, which are 3 MHz polarity and control modules.

I. SPECIFICATIONS OF MODEL BC 801  
3 MHz POLARITY AND CONTROL MODULE

A. General

The model BC 801 provides noncomplementary counting and polarity display. It accepts incoming up count and down count pulses and gates them with counter polarity information within the module to provide output forward and backward count pulses to drive the BC 803 Bidirectional Counter Module. Count gates are incorporated within the BC 801 so that both forward and backward output counts can be inhibited while the counter is being reset or preset. An additional count enable input to these count gates is provided; it permits gating of the forward and backward output signals by an external time base. For a photograph, see Fig. 2.

B. Specifications

Count Rate

0 to 3 MHz forward, backward, through zero, periodic, or aperiodic

Logic Levels

Logic zero -  $\leq +0.3$  V

Logic one -  $\geq +4.3$  V, typical with  $E_c = +5.0$  V

Input Signals

Up Count, Down Count - Logic one level present for 160 nsec minimum

Counter Decade Zero - 1 through 9 decade zero inputs



B. Specifications (Cont'd)

Count Gates

Reset (button) - Logic one inhibits forward and backward outputs; logic zero or open circuit enables forward and backward outputs.

Reset - Logic zero enables forward and backward outputs; logic one inhibits forward and backward outputs.

Preset - Function and loading similar to reset

Count Enable - Logic one or open circuit enables forward and backward outputs; logic zero inhibits forward and backward outputs.

Outputs

Sign Flip-Flop - Bipolar outputs

Counter Zero - Logic one when counter at zero

Forward Count,    Signals have same phase and pulsewidth as  
Backward Count - up count and down count, but they are gated by polarity logic.

Sign Logic

Up Count and Counter Zero = + Sign,  
Down Count and Counter Zero = - Sign.

Polarity Logic

Up Count and + Sign or Down Count and - Sign = Forward Count  
Down Count and + Sign or Up Count and - Sign = Backward Count Out

Propagation Time

(Up/Down Inputs to Forward Backward Outputs): 40 nsec maximum

Display

In-line "+" and "-" characters are 5/8 in. high.

Power Requirements

$E_c = +5$  Vdc,  $\pm 10\%$ , 90 mA maximum

$E_d = +180$  Vdc,  $\pm 5\%$ , 3.5 mA maximum with respect to common

Operating Temperature Range

-10°C to +60°C

## II. SPECIFICATIONS OF MODEL BC 803 3 MHz BIDIRECTIONAL DECADE COUNTER MODULE

### A. General

The BC 803 is a quasisimultaneous forward/backward decade counter and display. Each of the four DTuL flip-flops is clocked simultaneously with the received up and down inputs. The up and down inputs are gated with the counter states of 9 and 0, respectively, producing forward or backward carry outputs; this eliminates flip-flop delay times from the forward and backward carry outputs. Because the up and down inputs are dc gated to the flip-flops, pulses may not arrive simultaneously on these two lines; when one line is being used, the other must be at logic "0".

A common reset line is provided to reset the counter to zero. Each flip-flop has a set input which enables the counter to be set to any arbitrary number. These set and reset lines must be grounded when they are not being used.

The counter also provides a  $\overline{\text{zero}}$  output which indicates that the counter is at zero. The long-life, 10-line gas discharge display tube is driven by an all silicon discrete component decoder driver. For a photograph, see Fig. 3.

### B. Specifications

#### Logic Convention

0 V + 0.3 V = logic zero

4 V ± 0.5 V = logic one

A,B,C,D = 1,2,4,8 bits, respectively

B. Specifications (Cont'd)

Input Signals

Reset - Logic one resets all flip-flops  
A,B,C,D outputs to logic zero  
(160 nsec minimum)

Set - Logic one sets corresponding flip-flop to logic one  
(160 nsec minimum)

Up Count - Pulsed logic one adds one to the counter state  
(160 nsec minimum)  
6 mA sink load nominal

Down Count - Pulsed logic one subtracts one from the counter state  
(160 nsec minimum)  
6 mA sink load

Outputs Signals

Forward Carry Out - Pulsed logic one = up count input  
Will drive 10 mA sink load

Backward Carry Out - Pulsed logic one = down count input  
Will drive 10 mA sink load

$\bar{O}$  Out - Logic zero is the active signal  
Will drive 10 mA sink load

The unbarred flip-flop output is reset to logic zero.  
The barred flip-flop output is reset to logic one.

Power

+5 V at 150 mA nominal

+180 V at 3 mA nominal

Mating Connector: Janus 30 P or equivalent

Size

6-3/4 in. long x 3 in. high x 1 in. wide

Circuitry

All silicon semiconductor and integrated circuits

Operating Temperature

-10°C to +60°C

PARTS LIST BC 803 3 MHz FORWARD-BACKWARD COUNTER

Component Designation	Description	Manufacturers Part No.
<u>Drawing No. 1</u>		
	PC Board	B9000-514
	Display Tube	NL 803
	Case	D9000-030
	Case	D9000-031
	Socket (14 pin)	RTS 11
C1	Capacitor 0.1 $\mu$ F 10 V	
R1	Resistor 1/4 W, 5%	470 $\Omega$
R2	Resistor 1/4 W, 5%	470 $\Omega$
R3	Resistor 1/4 W, 5%	470 $\Omega$
R4	Resistor 1/4 W, 5%	470 $\Omega$
R5	Resistor 1/4 W, 5%	470 $\Omega$
R6	Resistor 1/4 W, 5%	1 k $\Omega$
R7	Resistor 1/4 W, 5%	1 k $\Omega$
R8	Resistor 1/4 W, 5%	470 $\Omega$
R9	Resistor 1/4 W, 5%	2.7 k $\Omega$
R10	Resistor 1/4 W, 5%	2.7 k $\Omega$
R11	Resistor 1/4 W, 5%	470 $\Omega$
R12	Resistor 1/4 W, 5%	2.7 k $\Omega$
R13	Resistor 1/4 W, 5%	2.7 k $\Omega$
R14	Resistor 1/4 W, 5%	470 $\Omega$
R15	Resistor 1/4 W, 5%	4.7 k $\Omega$
R16	Resistor 1/4 W, 5%	4.7 k $\Omega$
R17	Resistor 1/4 W, 5%	4.7 k $\Omega$
R18	Resistor 1/4 W, 5%	4.7 k $\Omega$
R19	Resistor 1/4 W, 5%	4.7 k $\Omega$
R20	Resistor 1/4 W, 5%	4.7 k $\Omega$
R21	Resistor 1/4 W, 5%	330 $\Omega$
R22	Resistor 1/4 W, 5%	4.7 k $\Omega$
R23	Resistor 1/4 W, 5%	10 k $\Omega$
R24	Resistor 1/4 W, 5%	27 k $\Omega$
CR 1	Diode	1N 914
CR 2	Diode	1N 914
CR 3	Diode	1N 914
CR 4	Diode	1N 914
CR 5	Diode	1N 914
CR 6	Diode	1N 914
CR 7	Diode	1N 914
Q1	Transistor	S1 5857
Q2	Transistor	S1 5857
Q3	Transistor	S1 5857
Q4	Transistor	S1 5857
Q5	Transistor	S1 5857
Q6	Transistor	S1 5857

PARTS LIST BC 803 3 MHz FORWARD-BACKWARD COUNTER (Cont'd)

Component Designation	Description	Manufacturers Part No.
-----------------------	-------------	------------------------

Drawing No. 1

Q7	Transistor	2N 3568
Q8	Transistor	2N 3568
Q9	Transistor	2N 3568
Q10	Transistor	2N 3568
Q11	Transistor	2N 3568
Q12	Transistor	2N 3568
Q13	Transistor	2N 3568
Q14	Transistor	2N 3568
Q15	Transistor	2N 3568
Q16	Transistor	2N 3568
Q17	Transistor	2N 3568
Q18	Transistor	2N 3568
F-F1	Integrated Circuit	C 7551K
F-F2	Integrated Circuit	C 7551K
F-F3	Integrated Circuit	C 7551K
F-F4	Integrated Circuit	C 7551K
G5	Integrated Circuit	C 7545K
G6	Integrated Circuit	C 7545K

Drawing No. 1A

R1	Resistor 1/4 W, 5%	2.7 k $\Omega$	
CR 1	Diode		1N 914
CR 2	Diode		1N 914
CR 3	Diode		1N 914

Drawing No. 1B

R1	Resistor 1/4 W, 5%	2.7 k $\Omega$	
CR 1	Diode		1N 914
CR 2	Diode		1N 914
CR 3	Diode		1N 914
CR 4	Diode		1N 914

PARTS LIST BC 801 3 MHz POLARITY AND CONTROL MODULE

Component Designation	Description	Manufacturers Part No.
	PC Board	B9000-445
	Display Tube	NL-811
	Case	D9000-030
	Case	D9000-031
	Socket (14 pin)	RTS 11
C1	Capacitor 0.1 $\mu$ F 10 V	
C2	Capacitor 12 pF	
C3	Capacitor 12 pF	
C4	Capacitor 0.1 $\mu$ F 10 V	
C5	Capacitor 12 pF	
R1	Resistor 1/4 W, 5%	15 k $\Omega$
R7	Resistor 1/4 W, 5%	4.7 k $\Omega$
R8	Resistor 1/4 W, 5%	4.7 k $\Omega$
R9	Resistor 1/4 W, 5%	330 $\Omega$
R10	Resistor 1/4 W, 5%	470 $\Omega$
R11	Resistor 1/4 W, 5%	4.7 k $\Omega$
R12	Resistor 1/4 W, 5%	47 k $\Omega$
R13	Resistor 1/4 W, 5%	4.7 k $\Omega$
R14	Resistor 1/4 W, 5%	470 $\Omega$
R15	Resistor 1/4 W, 5%	4.7 k $\Omega$
R16	Resistor 1/4 W, 5%	4.7 k $\Omega$
R17	Resistor 1/4 W, 5%	470 $\Omega$
R18	Resistor 1/4 W, 5%	1 k $\Omega$
R19	Resistor 1/4 W, 5%	470 $\Omega$
R20	Resistor 1/4 W, 5%	1 k $\Omega$
R21	Resistor 1/4 W, 5%	4.7 k $\Omega$
R22	Resistor 1/4 W, 5%	1 k $\Omega$
R23	Resistor 1/4 W, 5%	470 $\Omega$
R24	Resistor 1/4 W, 5%	2.7 k $\Omega$
R25	Resistor 1/4 W, 5%	4.7 k $\Omega$
R26	Resistor 1/4 W, 5%	1 k $\Omega$
R27	Resistor 1/4 W, 5%	270 $\Omega$
R28	Resistor 1/4 W, 5%	470 $\Omega$
R29	Resistor 1/4 W, 5%	2.7 k $\Omega$
R30	Resistor 1/4 W, 5%	4.7 k $\Omega$
R31	Resistor 1/4 W, 5%	1 k $\Omega$
R32	Resistor 1/4 W, 5%	270 $\Omega$
R33	Resistor 1/4 W, 5%	470 $\Omega$
R34	Resistor 1/4 W, 5%	470 $\Omega$
R35	Resistor 1/4 W, 5%	470 $\Omega$
Q1	Transistor	2N 3568
Q2	Transistor	2N 3568
Q3	Transistor	2N 4274
Q4	Transistor	2N 4274

PARTS LIST BC 801 (Cont'd)

Component Designation	Description	Manufacturers Part No.
-----------------------	-------------	------------------------

Drawing No. 2

Q5	Transistor	S1 5857
Q6	Transistor	S1 5857
Q7	Transistor	2N 4274
Q8	Transistor	2N 4274
Q9	Transistor	2N 4274
Q10	Transistor	2N 4274
IC 1	Integrated Circuit	C 7545K
IC 2	Integrated Circuit	C 7545K
IC 3	Integrated Circuit	C 7549K
IC 4	Integrated Circuit	C 7545K

Drawing No. 2A

R1	Resistor 1/4 W, 5%	2.7 k $\Omega$	
CR 1	Diode		1N 914
CR 2	Diode		1N 914
CR 3	Diode		1N 914

Drawing No. 2B

R1	Resistor 1/4 W, 5%	2.7 k $\Omega$	
CR 1	Diode		1N 914
CR 2	Diode		1N 914
CR 3	Diode		1N 914
CR 4	Diode		1N 914

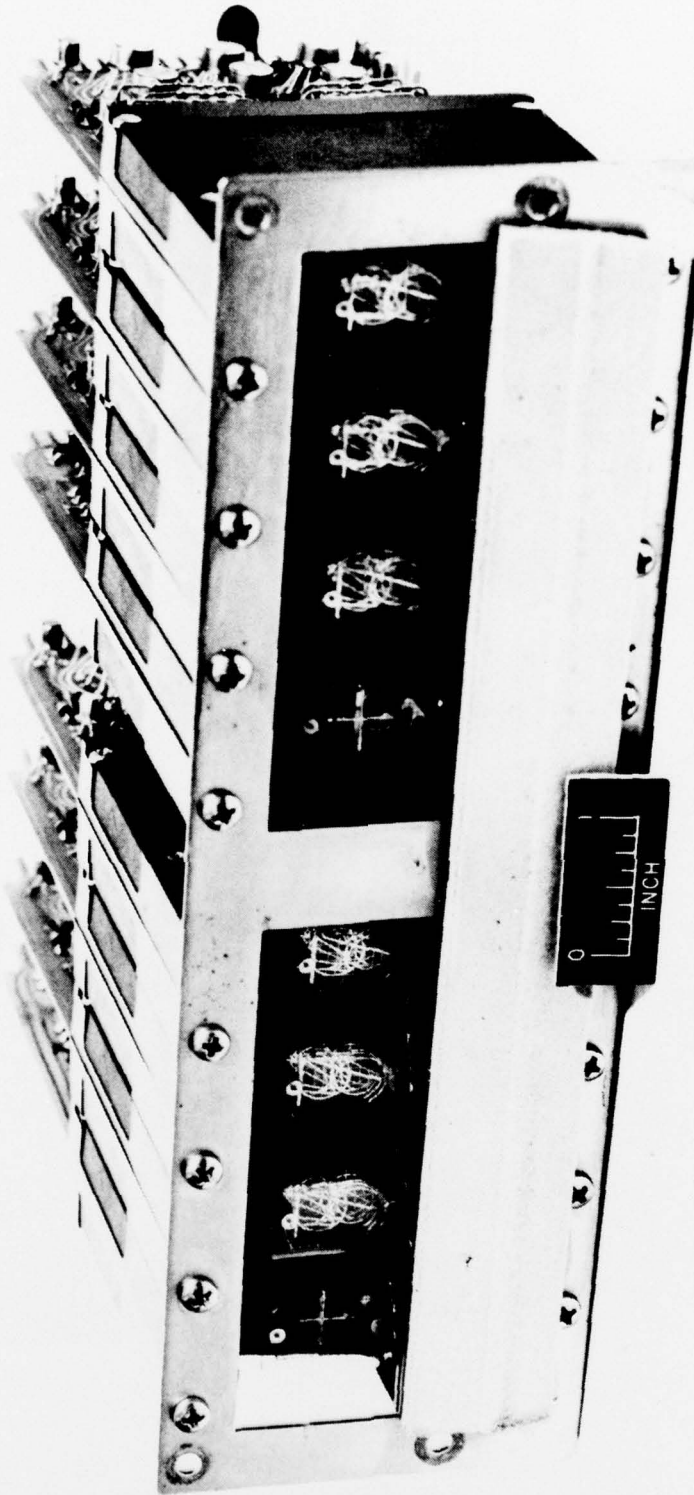
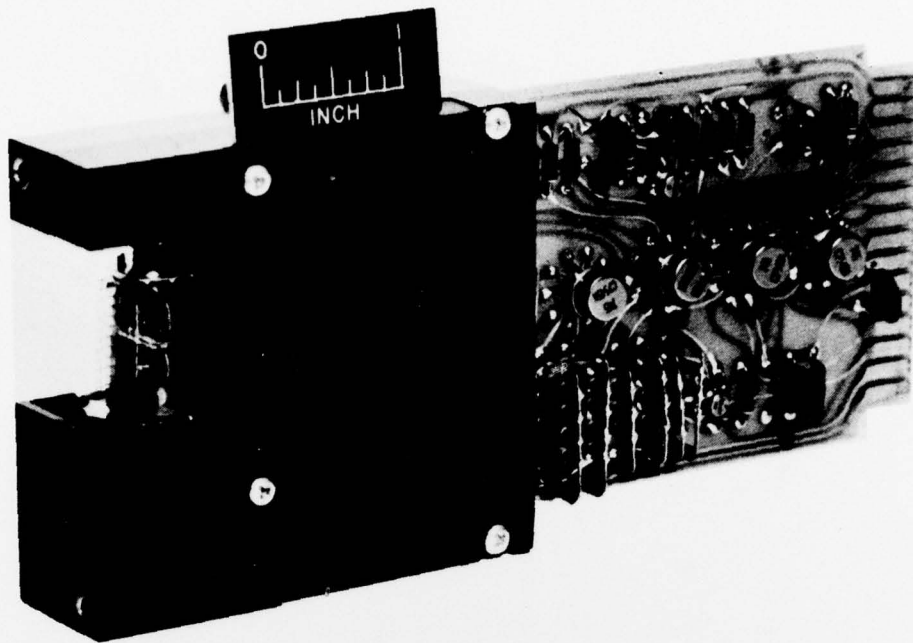
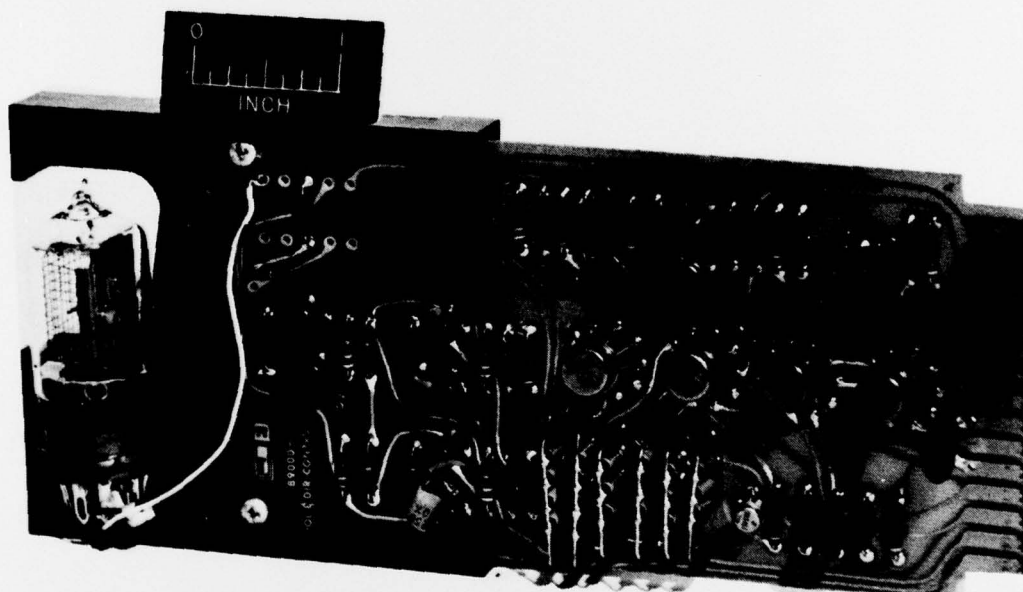

FIGURE 1  
DIGITAL READOUT DISPLAY PORTION OF  
THE PULSE VECTOR IMMITTANCE METER





WITH COVER



WITHOUT COVER

FIGURE 2  
MODEL BC 801  
3 MHz POLARITY AND CONTROL MODULE

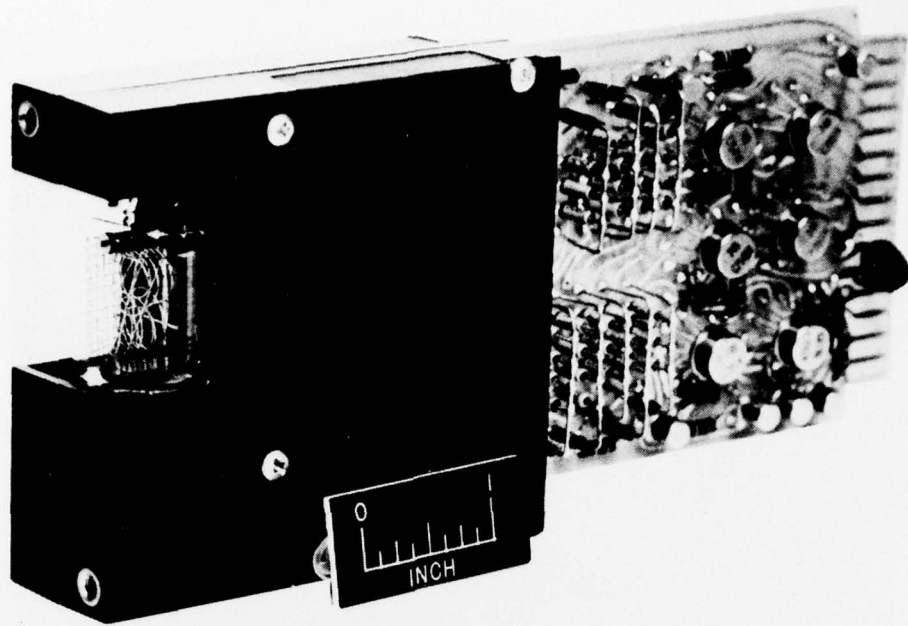

WITH COVER

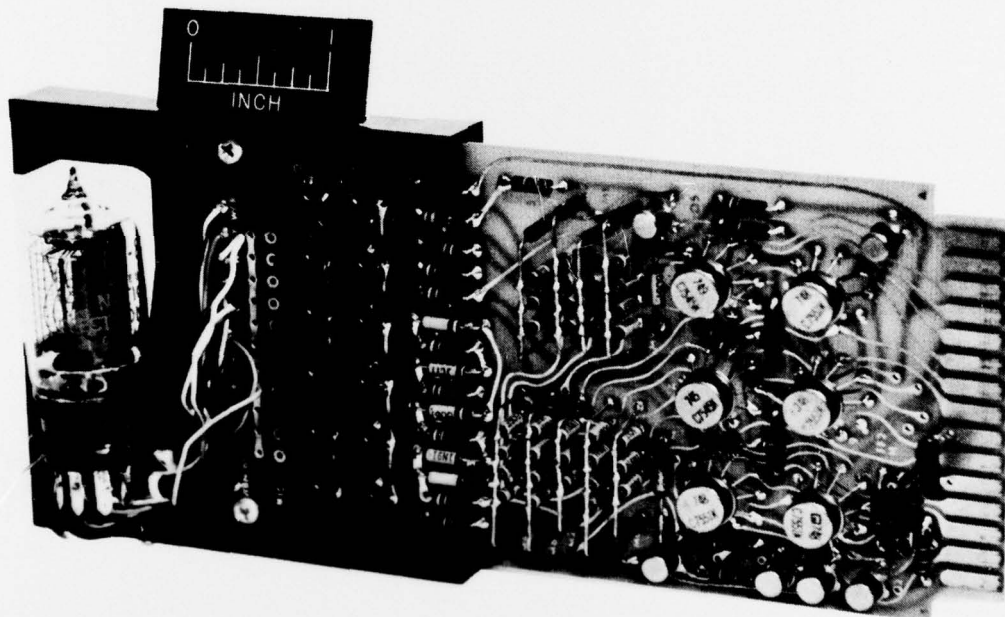

WITHOUT COVER

FIGURE 3  
MODEL BC 803  
3 MHz BIDIRECTIONAL DECADE COUNTER MODULE

25

~~FOR OPTIONAL USE ONLY~~

1748-6

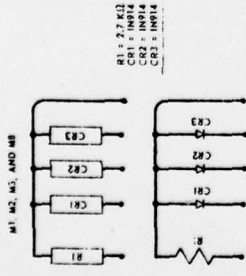

DRAWING No. 1-A

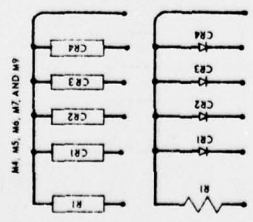

DRAWING No. 1-B

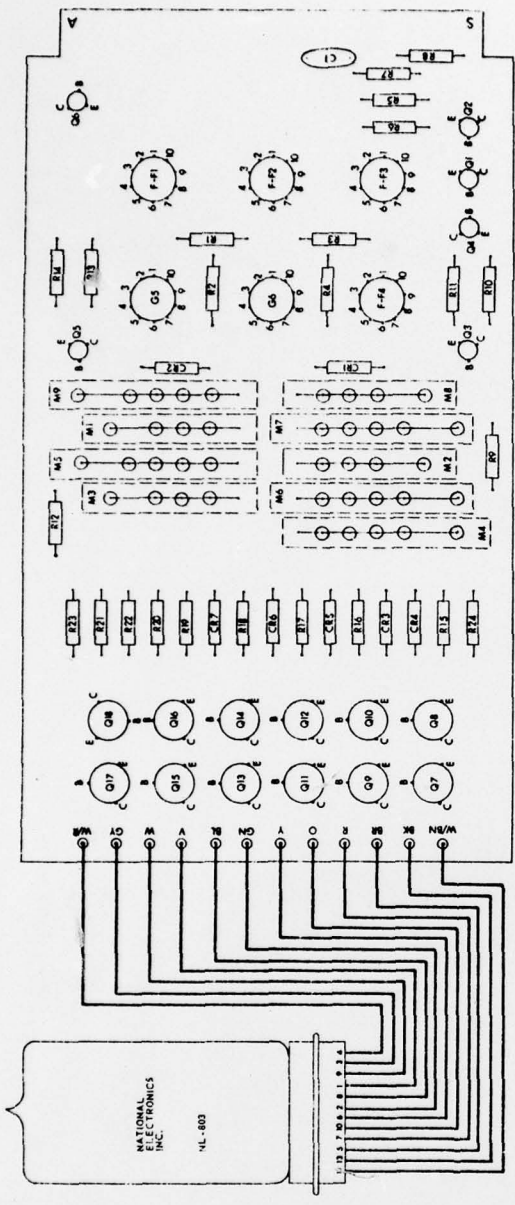

DRAWING No. 1

- C1 = 0.1 μF, 10V  
 CR1 = 10KΩ  
 CR2 = 10KΩ  
 CR3 = 10KΩ  
 CR4 = 10KΩ  
 CR5 = 10KΩ  
 CR6 = 10KΩ  
 CR7 = 10KΩ  
 CR8 = 10KΩ  
 CR9 = 10KΩ  
 CR10 = 10KΩ  
 CR11 = 10KΩ  
 CR12 = 10KΩ  
 CR13 = 10KΩ  
 CR14 = 10KΩ  
 CR15 = 10KΩ  
 CR16 = 10KΩ  
 CR17 = 10KΩ  
 CR18 = 10KΩ  
 CR19 = 10KΩ  
 CR20 = 10KΩ  
 CR21 = 10KΩ  
 CR22 = 10KΩ  
 CR23 = 10KΩ  
 CR24 = 10KΩ  
 C2 = 0.1 μF, 10V  
 C3 = 0.1 μF, 10V  
 C4 = 0.1 μF, 10V  
 M1 = 74C90  
 M2 = 74C90  
 M3 = 74C90  
 M4 = 74C90  
 M5 = 74C90  
 M6 = 74C90  
 M7 = 74C90  
 M8 = 74C90  
 O1 = 74C90  
 O2 = 74C90  
 O3 = 74C90  
 O4 = 74C90  
 O5 = 74C90  
 O6 = 74C90  
 O7 = 74C90  
 O8 = 74C90  
 F-F1 = 74C90  
 F-F2 = 74C90  
 F-F3 = 74C90  
 F-F4 = 74C90  
 R1 = 2.7 KΩ  
 R2 = 2.7 KΩ  
 R3 = 2.7 KΩ  
 R4 = 2.7 KΩ  
 R5 = 2.7 KΩ  
 R6 = 2.7 KΩ  
 R7 = 2.7 KΩ  
 R8 = 2.7 KΩ  
 R9 = 2.7 KΩ  
 R10 = 2.7 KΩ  
 R11 = 2.7 KΩ  
 R12 = 2.7 KΩ  
 R13 = 2.7 KΩ  
 R14 = 2.7 KΩ  
 R15 = 2.7 KΩ  
 R16 = 2.7 KΩ  
 R17 = 2.7 KΩ  
 R18 = 2.7 KΩ  
 R19 = 2.7 KΩ  
 R20 = 2.7 KΩ  
 R21 = 2.7 KΩ  
 R22 = 2.7 KΩ  
 R23 = 2.7 KΩ  
 R24 = 2.7 KΩ  
 TUBE = HL 803

NOTE: ALL RESISTORS 1/4 W, 5% TOLERANCE.  
 R1 = 2.7 KΩ  
 R2 = 2.7 KΩ  
 R3 = 2.7 KΩ  
 R4 = 2.7 KΩ  
 R5 = 2.7 KΩ  
 R6 = 2.7 KΩ  
 R7 = 2.7 KΩ  
 R8 = 2.7 KΩ  
 R9 = 2.7 KΩ  
 R10 = 2.7 KΩ  
 R11 = 2.7 KΩ  
 R12 = 2.7 KΩ  
 R13 = 2.7 KΩ  
 R14 = 2.7 KΩ  
 R15 = 2.7 KΩ  
 R16 = 2.7 KΩ  
 R17 = 2.7 KΩ  
 R18 = 2.7 KΩ  
 R19 = 2.7 KΩ  
 R20 = 2.7 KΩ  
 R21 = 2.7 KΩ  
 R22 = 2.7 KΩ  
 R23 = 2.7 KΩ  
 R24 = 2.7 KΩ

COMPONENT LAYOUT OF PC CARD B9000-514  
 FOR JANUS MODULE BC 803  
 3 MHz BIDIRECTIONAL DECADE COUNTER MODULE

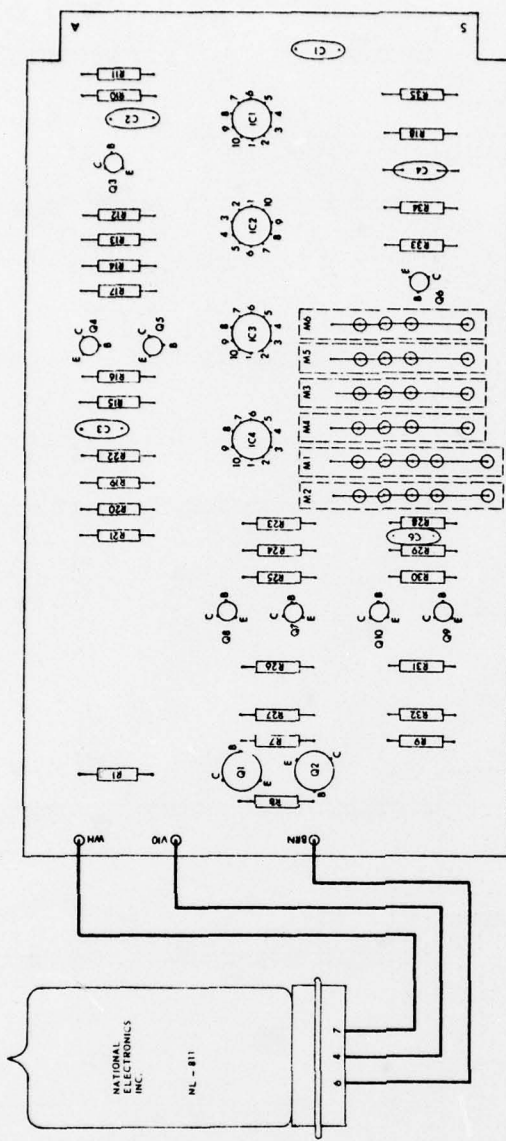

- DRAWING No. 2
- C1 = 0.1 μF 10 V  
 C2 = 10 μF  
 C3 = 10 μF  
 C4 = 0.1 μF
- IC1 = C2545 K  
 IC2 = C7545 K  
 IC3 = C7545 K  
 IC4 = C2545 K
- D1 = 2N3568  
 D2 = 2N3568  
 D3 = 2N4274  
 D4 = 2N4274  
 D5 = 2N4274  
 D6 = 2N4274  
 D7 = 2N4274  
 D8 = 2N4274  
 D9 = 2N4274  
 D10 = 2N4274
- TUBE = NL 811

- R1 = 15 KΩ  
 R2 = 4.7 KΩ  
 R3 = 4.7 KΩ  
 R4 = 4.7 KΩ  
 R5 = 330 Ω  
 R6 = 2.7 KΩ  
 R7 = 2.7 KΩ  
 R8 = 1 KΩ  
 R9 = 1 KΩ  
 R10 = 2.7 KΩ  
 R11 = 2.7 KΩ  
 R12 = 4.7 KΩ  
 R13 = 4.7 KΩ  
 R14 = 470 Ω  
 R15 = 4.7 KΩ  
 R16 = 4.7 KΩ  
 R17 = 470 Ω  
 R18 = 1 KΩ  
 R19 = 470 Ω  
 R20 = 470 Ω  
 R21 = 4.7 KΩ  
 R22 = 4.7 KΩ  
 R23 = 4.7 KΩ  
 R24 = 4.7 KΩ  
 R25 = 4.7 KΩ
- NOTE: ALL RESISTORS 1/4 W. 5% TOLERANCE

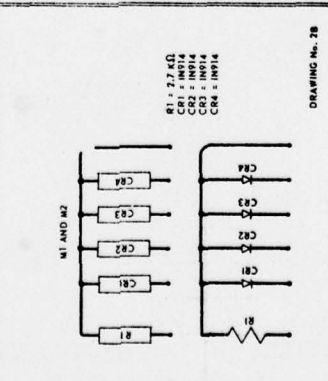
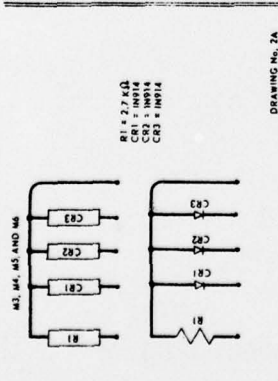

COMPONENT LAYOUT OF PC CARD B9000-445  
 FOR JANUS MODULE BC 801  
 3 MHz POLARITY AND CONTROL MODULE

FOR OFFICIAL USE ONLY

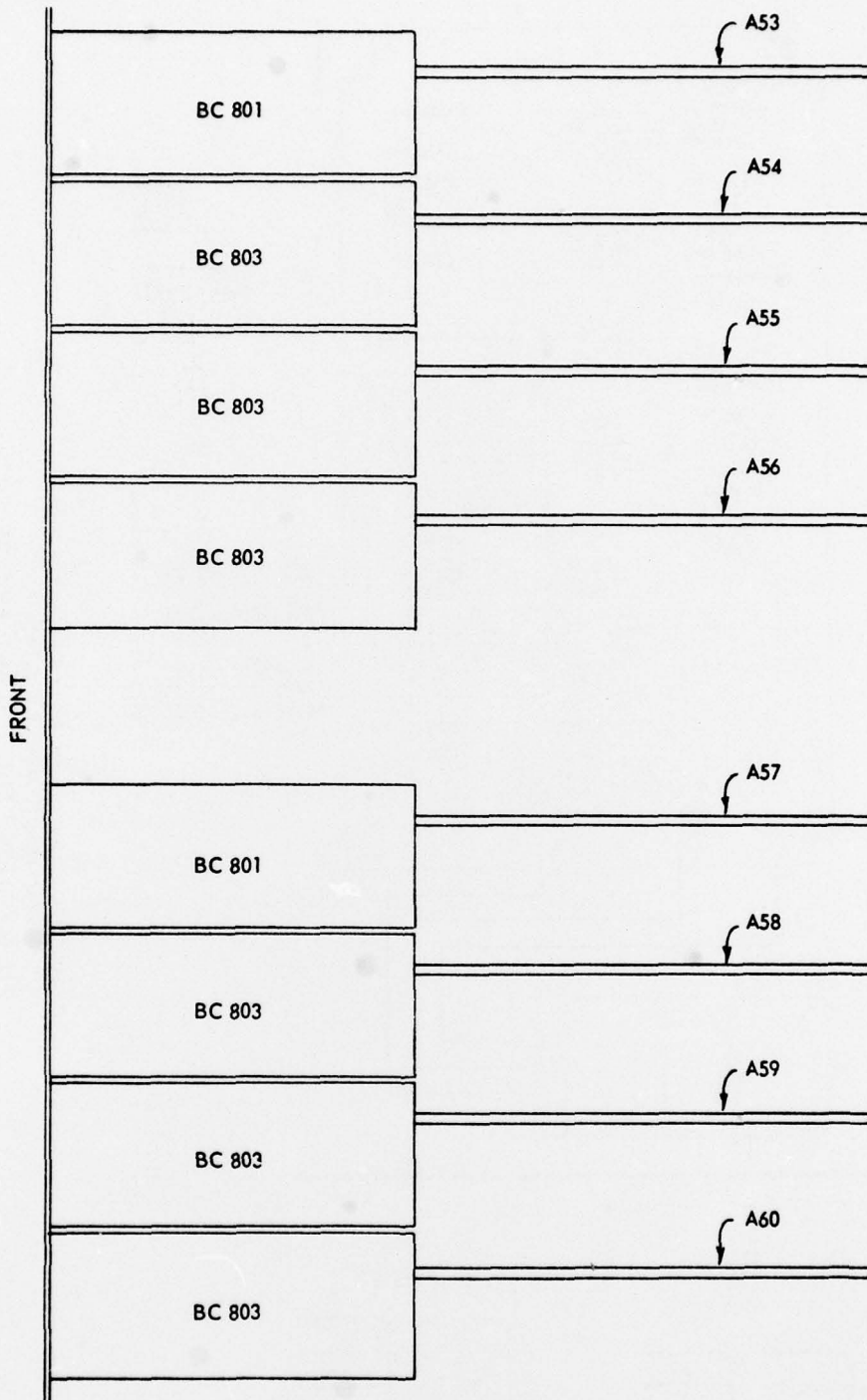

TOP VIEW OF READOUT ASSEMBLY

PC BOARD LAYOUT OF THE DIGITAL READOUT DISPLAY  
DRAWING No. 3

ARL - UT  
AS-73-940  
GGW - DR  
9 - 20 - 73

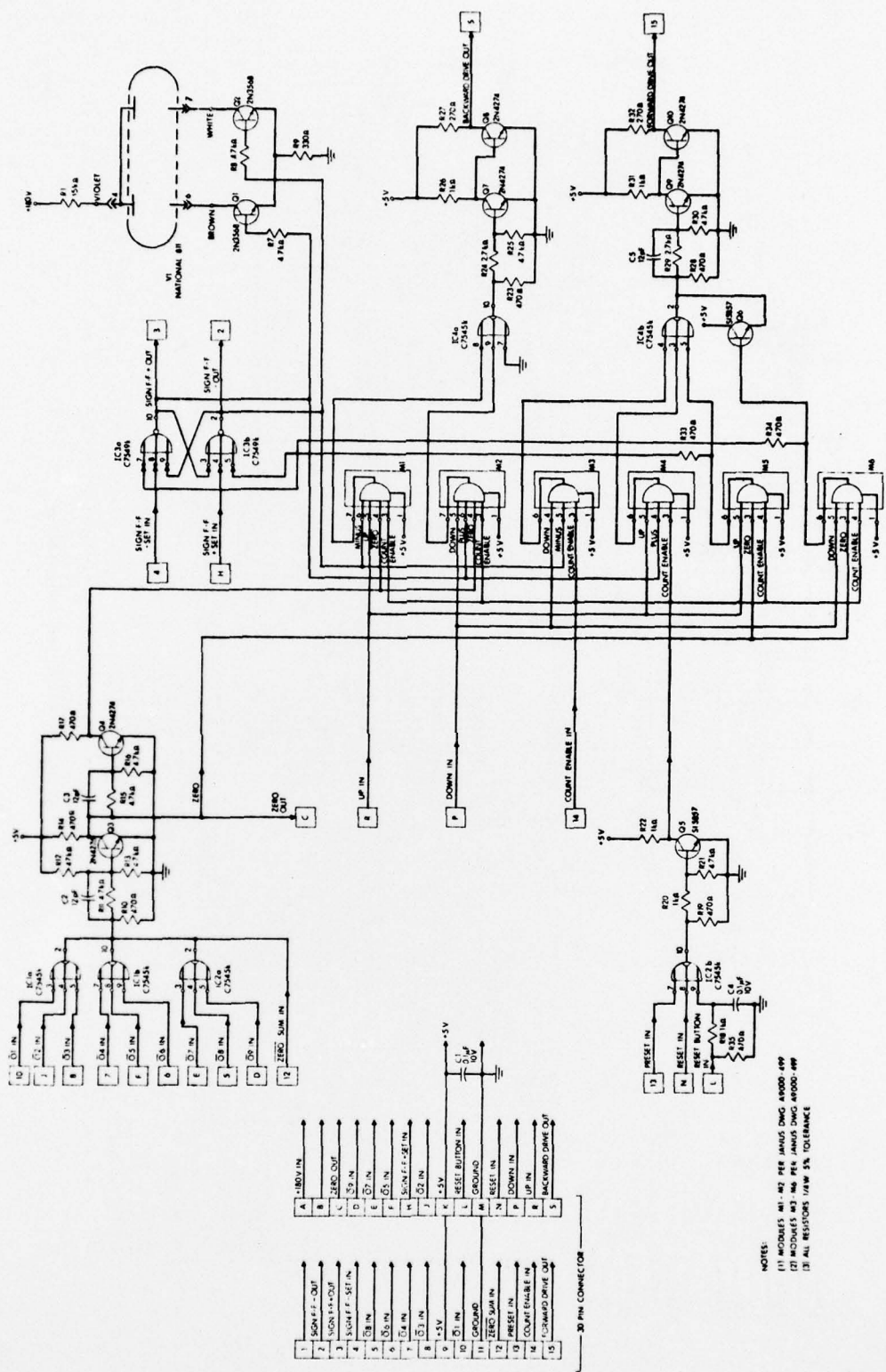

DRAWING No. 4

SCHEMATIC 3 MHz POLARITY AND CONTROL MODULE

- NOTES:
- (1) MODULES M1, M2 PER JANGS DNG A9000-499
  - (2) MODULES M3, M6 PER JANGS DNG A9000-499
  - (3) ALL RESISTORS 1/4W 5% TOLERANCE

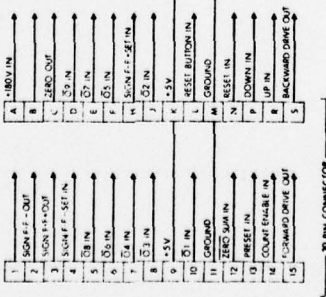

~~FOR INTERNAL USE ONLY~~

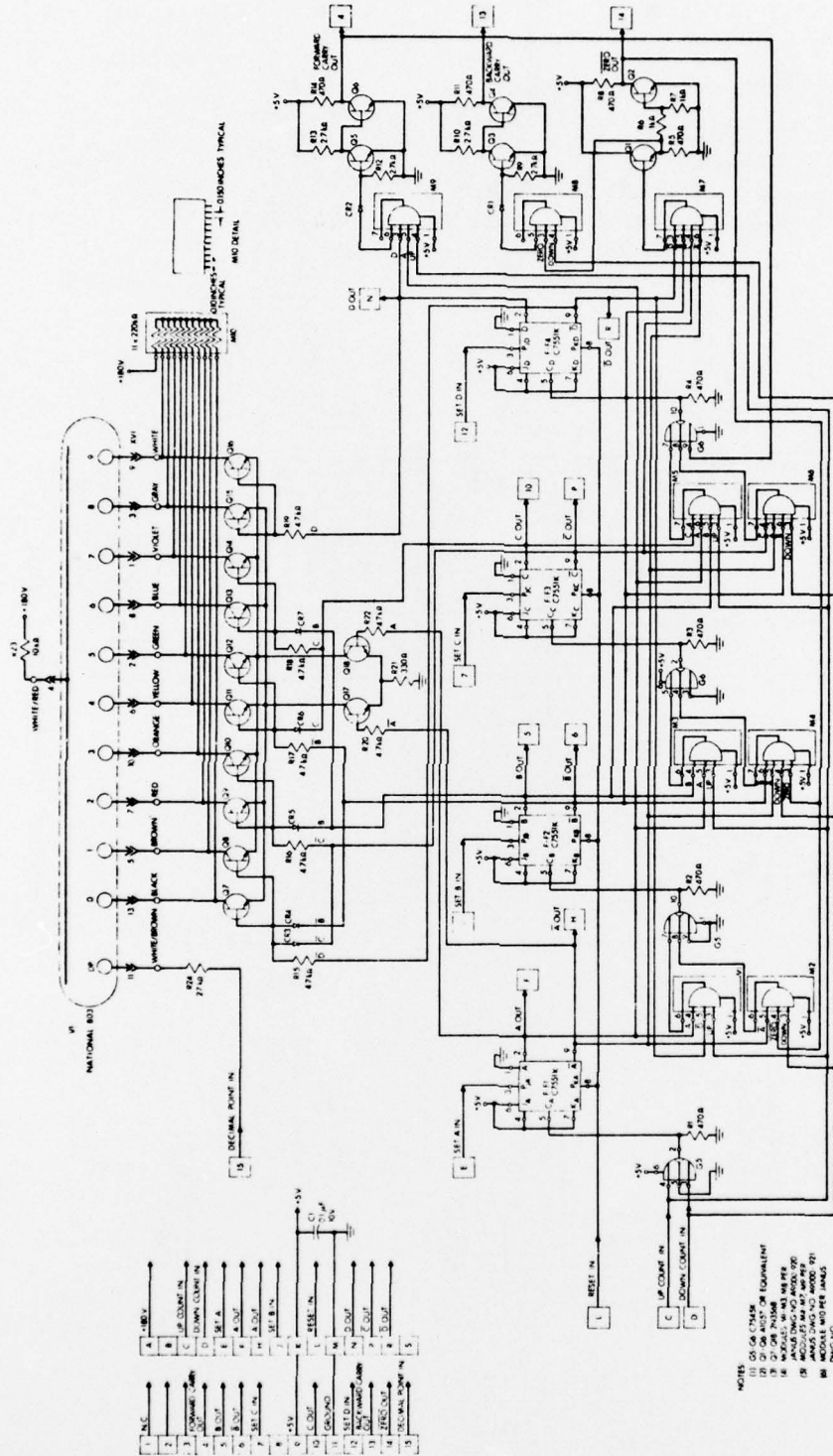

TEST NUMBER	CHARACTER
1	BC 801 IN 801
2	BC 802 IN 802
3	BC 803 IN 803
4	BC 804 IN 804
5	BC 805 IN 805
6	BC 806 IN 806
7	BC 807 IN 807
8	BC 808 IN 808
9	BC 809 IN 809
10	BC 810 IN 810

3 MHz FORWARD-BACKWARD COUNTER WITH TEN LINE DISPLAY

DRAWING No. 3

NOTE:  
 (1) USE OF CHECK  
 (2) USE OF ADJUST OR EQUIPMENT  
 (3) USE OF ADJUST OR EQUIPMENT  
 (4) USE OF ADJUST OR EQUIPMENT  
 (5) USE OF ADJUST OR EQUIPMENT  
 (6) USE OF ADJUST OR EQUIPMENT  
 (7) USE OF ADJUST OR EQUIPMENT  
 (8) USE OF ADJUST OR EQUIPMENT  
 (9) USE OF ADJUST OR EQUIPMENT  
 (10) USE OF ADJUST OR EQUIPMENT  
 (11) USE OF ADJUST OR EQUIPMENT  
 (12) USE OF ADJUST OR EQUIPMENT  
 (13) USE OF ADJUST OR EQUIPMENT  
 (14) USE OF ADJUST OR EQUIPMENT  
 (15) USE OF ADJUST OR EQUIPMENT  
 (16) USE OF ADJUST OR EQUIPMENT  
 (17) USE OF ADJUST OR EQUIPMENT  
 (18) USE OF ADJUST OR EQUIPMENT  
 (19) USE OF ADJUST OR EQUIPMENT  
 (20) USE OF ADJUST OR EQUIPMENT

13 May 1974

DISTRIBUTION LIST FOR  
QUARTERLY PROGRESS REPORT NO. 7  
CONTRACT NO0126-72-C-1748  
27 December 1973 - 26 March 1974  
FOR OFFICIAL USE ONLY

Copy No.

1 - 6	Commander Naval Ship Systems Command Department of the Navy Washington, DC 20362 Attn: Mr. Herman Evans, PMS 302-7D
7	Procurement Contracting Officer Ships Parts Control Center Mechanicsburg, PA 17055 Attn: Code 774
8	Office of Naval Research Resident Representative Room 582, Federal Building 300 East 8th Street Austin, TX 78701
9	Dudley D. Baker, ARL/UT
10	James E. Stockton, ARL/UT
11	Gary G. Warren, ARL/UT
12	Library, ARL/UT



UNCLASSIFIED

SECURITY CLASSIFICATION OF THIS PAGE (When Data Entered)

REPORT DOCUMENTATION PAGE		READ INSTRUCTIONS BEFORE COMPLETING FORM
1. REPORT NUMBER	2. GOVT ACCESSION NO.	3. RECIPIENT'S CATALOG NUMBER
4. TITLE (and Subtitle) TECHNICAL AND MATERIAL SUPPORT FOR THE AN/FQM-10(V) SONAR TEST SET AND NAVAL SHIPYARD TRANSDUCER REPAIR FACILITY TEST SITES		5. TYPE OF REPORT & PERIOD COVERED quarterly progress report 27 Dec 1973 - 26 Mar 1974
7. AUTHOR(s) James E. Stockton Gary G. Warren		6. PERFORMING ORG. REPORT NUMBER
9. PERFORMING ORGANIZATION NAME AND ADDRESS Applied Research Laboratories The University of Texas at Austin Austin, Texas 78712		8. CONTRACT OR GRANT NUMBER(s) N00126-72-C-1748
11. CONTROLLING OFFICE NAME AND ADDRESS Naval Ship Engineering Center Department of the Navy Washington, D. C. 20360		10. PROGRAM ELEMENT, PROJECT, TASK AREA & WORK UNIT NUMBERS Proj. Ser. No. N65539-2137-0045
14. MONITORING AGENCY NAME & ADDRESS (if different from Controlling Office)		12. REPORT DATE 8 May 1974
		13. NUMBER OF PAGES 31
		15. SECURITY CLASS. (of this report) UNCLASSIFIED
		16. DECLASSIFICATION/DOWNGRADING SCHEDULE
16. DISTRIBUTION STATEMENT (of this Report) <del>UNCLASSIFIED</del>		
17. DISTRIBUTION STATEMENT (of the abstract entered in Block 20, if different from Report)		
18. SUPPLEMENTARY NOTES		
19. KEY WORDS (Continue on reverse side if necessary and identify by block number) AN/FQM-10(V) Sonar Test Set Transducer Repair Facility (TRF) Pulse Vector Immittance Meter (PVIM) Sampling Digital Voltmeter (SDVM)		
20. ABSTRACT (Continue on reverse side if necessary and identify by block number) ARL repaired and calibrated a PVIM from NAVSHIPYDPTSMH and received a new PVIM from Scientific-Atlanta. ARL personnel have produced an addendum to the PVIM instruction manual and have traveled to Atlanta, Georgia, to discuss the reprinting of the operators' manuals. ARL personnel have attended STEP Working Group Meeting No. 15 and have traveled to NAVSHIPYDPTSMH to repair units of the AN/FQM-10(V) test sets. ARL continues to provide technical and material support for the AN/FQM-10(V) sets and the TRF test sites. (U)		

DD FORM 1473  
1 JAN 73EDITION OF 1 NOV 65 IS OBSOLETE  
S/N 0102-014-6601

UNCLASSIFIED

SECURITY CLASSIFICATION OF THIS PAGE (When Data Entered)