

AD-A070 964

BOEING AEROSPACE CO SEATTLE WASH  
CYCLOPHORIA AND PILOT PREDICTION OF THE RUNWAY PLANE.(U)  
FEB 79 C L KRAFT, C D ANDERSON, H VON TOBEL

F/G 5/10

UNCLASSIFIED

AFOSR-TR-79-0830

NL

1 of 2

AD  
A070 964

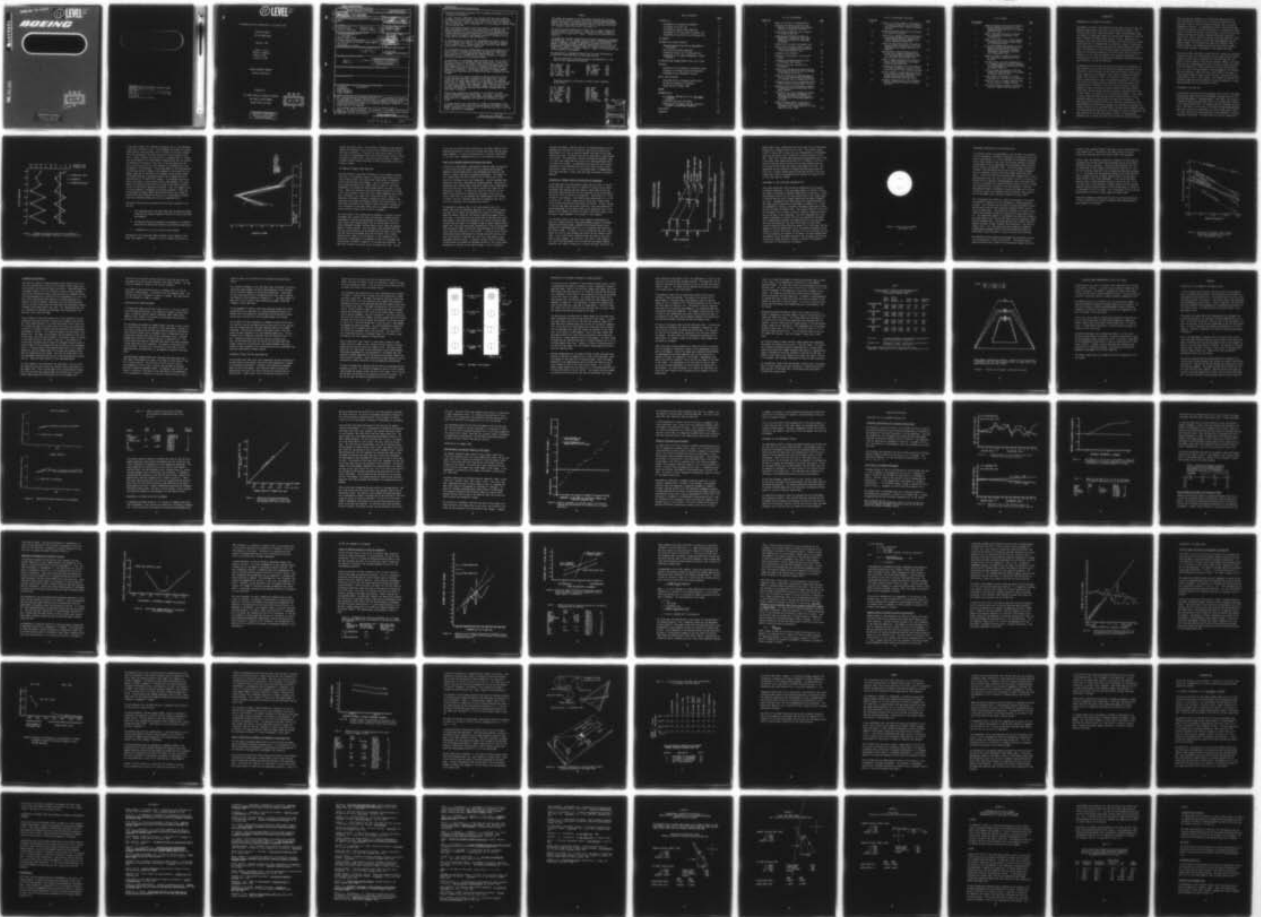

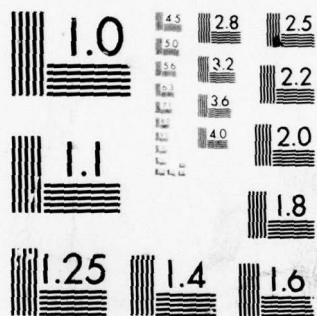

MICROCOPY RESOLUTION TEST CHART  
NATIONAL BUREAU OF STANDARDS-1963-A



AFOSR-TR-79-0830



LEVEL II

**BOEING**

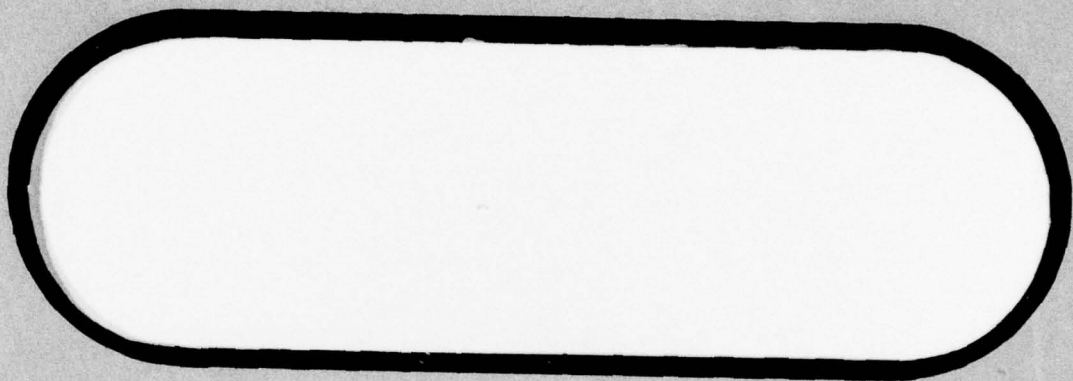

A070964

UUC FILE COPY

DDC  
RECEIVED  
JUL 10 1979  
RECEIVED

B

DISTRIBUTION STATEMENT A  
Approved for public release;  
Distribution Unlimited

79 07 09 006

**AIR FORCE OFFICE OF SCIENTIFIC RESEARCH (AFSC)  
NOTICE OF TRANSMITTAL TO DDC**

This technical report has been reviewed and is  
approved for public release IAW AFR 190-12 (7b).  
Distribution is unlimited.

**A. D. BLOSE**  
Technical Information Officer

**LEVEL II**

CYCLOPHORIA AND PILOT PREDICTION OF THE RUNWAY PLANE

TECHNICAL REPORT

LIFE SCIENCES/AFOSR

February, 1979

Conrad L. Kraft  
Charles D. Anderson  
Helen von Tobel  
Jeffery D. Kosan

BOEING AEROSPACE COMPANY

Seattle, Washington

Prepared for

AIR FORCE OFFICE OF SCIENTIFIC RESEARCH

AIR FORCE SYSTEMS COMMAND

UNITED STATES AIR FORCE

DDC  
RECEIVED  
JUL 10 1979  
RECEIVED  
B

**DISTRIBUTION STATEMENT A**

Approved for public release;  
Distribution Unlimited



UNCLASSIFIED

SECURITY CLASSIFICATION OF THIS PAGE (When Data Entered)

19 REPORT DOCUMENTATION PAGE		READ INSTRUCTIONS BEFORE COMPLETING FORM	
1. REPORT NUMBER	2. GOVT ACCESSION NO.	3. RECIPIENT'S CATALOG NUMBER	
AFOSR-TR-79-0830			
4. TITLE (and Subtitle)		5. TYPE OF REPORT & PERIOD COVERED	
CYCLOPHORIA AND PILOT PREDICTION OF THE RUNWAY PLANE.		Final Report, March 1978 - Dec 1978	
7. AUTHOR(s)		6. PERFORMING ORG. REPORT NUMBER	
Conrad L. Kraft Charles D. Anderson			
Helen von Tobel Jeffrey D. Kosan		8. CONTRACT OR GRANT NUMBER(s)	
		F49620-78-C-0052	
9. PERFORMING ORGANIZATION NAME AND ADDRESS		10. PROGRAM ELEMENT, PROJECT, TASK AREA & WORK UNIT NUMBERS	
The Boeing Aerospace Co. P. O. Box 3999 Seattle, Wash. 98124		61102F 2313/A2	
11. CONTROLLING OFFICE NAME AND ADDRESS		12. REPORT DATE	
Air Force Office of Scientific Research (NL) Building 410 Bolling AFB, D.C. 20332		February 1979	
14. MONITORING AGENCY NAME & ADDRESS (if different from Controlling Office)		13. NUMBER OF PAGES	
(12) 99p.		98	
		15. SECURITY CLASS. (of this report)	
		Unclassified	
		15a. DECLASSIFICATION/DOWNGRADING SCHEDULE	
16. DISTRIBUTION STATEMENT (of this Report)			
Approved for public release; Distribution unlimited.		DISTRIBUTION STATEMENT A Approved for public release; Distribution Unlimited	
17. DISTRIBUTION STATEMENT (of the abstract entered in Block 20, if different from Report)			
18. SUPPLEMENTARY NOTES			
19. KEY WORDS (Continue on reverse side if necessary and identify by block number)			
Cyclophoria                      Cyclotorsion Cyclorotation Runway Perception Visual Perception			
20. ABSTRACT (Continue on reverse side if necessary and identify by block number)			
This investigation had two primary objectives: (1) to determine the direction and magnitude of cyclophoria resting states in a sample of observers taken from a select population (AF pilots); (2) to determine whether the magnitude of cyclophoria found had the potential of affecting the pilots' perception of the runway plane on final approach.  The Circle/Bar test was administered to 12 pilots under 0,5 and 10 degrees of instrument convergence. The increases in convergence significantly			

059610

Har

Increased the measured cyclophoria from .01 degrees encyclophoric to .65 and .82 degrees excyclophoric.

A second, previously developed, test (the ARC test) was used to measure cyclophoria under conditions of a more complex and structured image than the Circle/Bar test. The ARC test was given with zero and  $\pm$  two degrees of image cyclorotation, which corresponded to  $\pm$  114 arc seconds of induced disparity into the ARC test.

Image cyclorotation produced significant effects in responses on the ARC test, with observed shifts, in the expected direction from the non-rotated condition, of 13.5 and 13.6 arc seconds for two degrees excyclo-rotation and encyclo-rotation respectively. The magnitude of this shift is only about 12 percent of the induced disparity, a reflection of the interaction of the complex stimulus pattern.

An unexpected result in the ARC test responses was an overall shift of 11.5 arc seconds (encyclophoric) in the ARC test responses as compared with the physical null. Review of data from a previous study showed a similar shift, as yet not fully understood.

Also unexpected, and not yet understood, was the low and negative correlation (-.34 N.S.) between the individual cyclophorias as measured by the Circle/Bar test and those derived from the ARC test. It is suspected that this is a reflection of a complex interplay of cyclophoria and central processing of the disparate images.

The technique of  $\pm$  two degrees image cyclorotation was also utilized in the test of the pilot's perception of the runway plane. In this test, photographic images of CGI runways, taken on a three degree glide slope, were presented in pairs, the first as a standard, non-cyclorotated (on glide slope) image and the second as a comparison with zero, or  $\pm$  two degrees of cyclorotation. The observer was asked to indicate whether the comparison image was above or below glide slope as compared with the standard.

As with the ARC test, image cyclorotation produced significant effects in the predicted direction in responses to the runway test. Encyclo-rotation of the runway image resulted in 61 percent of the responses being "high" or "above glide slope," while two degrees of excyclo-rotation yielded only 41 percent "high" responses. Other conditions, such as day vs. night runway scenes, three different runways, and different distances to the runway, had non-significant effects although there were some trends in the data.

These results substantiate the potential of cyclophoria to affect a pilot's perception of the runway plane. The pilots' individual cyclophorias and their perception of the runway plane appear to be correlated, but not in a magnitude sufficient to be statistically significant.

To further establish this relationship, a method of measurement of the perception of the runway plane with greater degrees of freedom is recommended. Subsequently a direct test in a flight simulator with a real time visual scene was also recommended.

PREFACE

This report was prepared by the Crew Systems Technology and Simulators Organization of Logistics Support and Services, Boeing Aerospace Company, Seattle, Washington. The work was done under USAF contract F 49620-78-C-0052 for the Life Sciences Directorate of the Air Force Office of Scientific Research (AFSC), Bolling Air Force Base, D.C.

The authors are most appreciative of Major Jack A. Thorpe's support and advice as monitor of this contract. Thanks are also due Dr. Charles L. Elworth for his reviews and Dr. James S. Briggs for his consultation on statistics.

The authors are especially appreciative of the most cooperative assistance of McChord AFB. Lt. Col. Perdue, Assistant Chief, Aircrew Standards/Evaluation, 62 MAW/DOV, arranged for quarters for the data collection at McChord, discussed with and arranged for participation of all pilots, and maintained all schedules among all other activities of the base and the needs of the contract. His special effort, in behalf of this contract work, is most gratefully acknowledged.

Our appreciation is extended to these pilots for their participation, without which these data would not have been possible.

Those participating in the Survey and Main Experimentation, in the order of their scheduled participation.

Capt. Upchurch	8th.	Capt. Blackman	8th.
Capt. Hodges	8th.	Capt. Odle	4th.
Lt. Col. Dahl	4th.	Major. Robbins	62nd.
1st. Lt. Berg	36th.	Capt. Lamphear	8th.
1st. Lt. Barrowclough	36th.	Lt. Robinson	4th.
Capt. Steele	8th.	1st. Lt. Coil	36th.
Capt. Griffiths	36th.		

Those participating in the Survey in order of their scheduled participation.

Lt. Col. Barnett	4th.	Capt. Brown	8th.
1st. Lt. Smith	4th.	Capt. Kent	4th.
1st. Lt. Woodbury	4th.	Capt. Olsen	62nd.
Capt. Jaques	8th.	Major. Baughman	Wing.
Lt. Col. Clyde	62nd.	Capt. Markham	4th.
Lt. Withers	36th.	Capt. Stevens	
Lt. Hagen	36th.	Capt. Collins	36th.
Capt. Peterson	4th.	1st. Lt. Williams	36th.
2nd. Lt. Hager	4th.		

ON for		
DDC	White Section	<input checked="" type="checkbox"/>
UNANNOUNCED	Buff Section	<input type="checkbox"/>
JUSTIFICATION _____		
BY _____		
DISTRIBUTION/AVAILABILITY CODES		
Dist.	AVAIL	and/or SPECIAL
<b>A</b>		



## TABLE OF CONTENTS

	<u>Page</u>
INTRODUCTION	1
BACKGROUND OF CYCLOPHORIA DEVELOPMENTS	1
CYCLOPHORIA IN THE ARC TEST	2
THE PROBLEM OF RUNWAY PLANE PERCEPTION	8
DEVELOPMENT OF THE CIRCLE/BAR CYCLOPHORIA TEST	12
EXPERIMENTAL APPLICATION OF THE CIRCLE/BAR TEST	14
THE PROBLEM	17
EQUIPMENT AND STIMULUS MATERIALS	18
TROSCOPE MODIFICATION FOR THE MEASUREMENT OF CYCLOPHORIA	18
MODIFICATION OF SECOND TROSCOPE	20
ALTERNATIVE STIMULI FOR THE CIRCLE/BAR TEST	21
PREPARATION OF THE RUNWAY PHOTOGRAPHIC STIMULUS MATERIALS	24
ALTERNATING RAMP CHROMOSTEREOPSIS (ARC) TEST STIMULI	29
PROCEDURE	30
EVALUATION OF THE ALTERNATIVE CYCLOPHORIA STIMULI	30
SCREENING OF AIR FORCE PILOTS FOR CYCLOPHORIA	34
PROCEDURES IN THE EXPERIMENTAL SESSION	40
RESULTS AND DISCUSSION	41
CIRCLE/BAR TEST OF CYCLOPHORIA RESTING STATE	41
THE ARC TEST MEASURE OF CYCLOPHORIA	50
PERCEPTION OF THE RUNWAY PLANE	58
SUMMARY	69
RECOMMENDATIONS	72
AS A POSSIBLE CONTRIBUTION TO THE " <u>DUCK UNDER</u> " PHENOMENON	72
CYCLOPHORIA AND GLIDE SLOPE ANGLE	73
PERCEPTION OF THE RUNWAY PLANE AND TRAINING OF VOLUNTARY CYCLOTORSIONAL MOVEMENTS	75
BIBLIOGRAPHY	76
APPENDICES	81

LIST OF ILLUSTRATIONS

<u>Figure No.</u>		<u>Page</u>
1	Model for ARC Test of Chromostereopsis	3
2	Response Distribution by Row Pairs for Observer #1 on Achromatic and Chromatic Versions of Format B of ARC Test	5
3	Distribution of Responses on Six Formats of Achromatic ARC Test	7
4	Generated and Estimated Altitudes for Approaches to Contiguous City Flight Pattern as a Function of Topography and Runways	11
5	Format of the Circle/Bar Cyclophoria Test	13
6	Prediction of Altitude at 8220' Distance From Pilot's Perception of Verticality in the Fronto-Parallel Plane	16
7	Cyclophoria Test Patterns	23
8	Patterns of the Runways in the Pictorial Stimuli	28
9	Estimates of Cyclophoria Resting State by Different Test Patterns	31
10	Quotidian and Diurnal Variability of Cyclophoria	33
11	Prediction of Average Cyclorotation Resting State Based on 20 Trials From the Average of the 10th to 15th Trials	35
12	Range of Cyclophoria in Screening Sample of 30 Pilots as Inferred From Cyclorotation of Circle/Bar Test to Achieve Verticality	38
13	Cyclophoria Data by Trial 12 Observers During Both Screening and Experimental Sessions	42
14	Regression Lines for the Cyclophoria Data on 12 Observers During Screening and Experi- mental Sessions	42
15	The Effect of 0, 5 and 10 Degrees of Conver- gence in Troposcope (Stereoscope) on Cyclorotation Settings to Verticality in Circle/Bar Test (for Selected Sample of 12 Pilots)	43
16	Comparisons Among Several Investigator's Data on the Effect of Convergence on Cyclophoria (All except Kraft, et al. data taken from Allen, 1954)	45



LIST OF ILLUSTRATIONS (Continued)

<u>Figure No.</u>		<u>Page</u>
17	Effects of 5 and 10 degrees of Convergence on Circle/Bar Settings for Each of 12 Observers (Plotted Against 0 degree Convergence Settings)	46
18	Relationship Between Magnitude of Cyclophoria and Intertrial Variance	48
19	Effects of + 2 degrees of Image Cyclorotation on Responses on ARC Test for Each of 12 Pilots (Plotted Against 0 degrees Cyclorotation Responses as Baseline)	51
20	Effects of Image Cyclorotation on Perceived Crossover Point (Verticality) in Arc Test Compared With the Induced Disparity (12 Observers)	52
21	Observed Versus Predicted Response Shifts on ARC Test (0 degrees Convergence) for 12 Pilots Based Upon Cyclophoria Resting Point Inferred From Circle/Bar Test	57
22	Effect of Image Cyclorotation on the Percentage of "High" Responses on the Runway Glideslope Perception Test	59
23	Influence of Cyclorotation on the Proportion of "Higher" Estimates of Aircraft's Altitude as Length of Visual Features Decreases	61
24	The Main Effects of Time-of-Day and Distance on the Percent "Correct" Responses on the Runway Glide-Slope Perception Test (neither main effect was significant)	64
25	Conceptual Interpretation of How Cyclophoria Effects Binocular Perception of the Runway Plane	66

LIST OF TABLES

<u>Table Number</u>		<u>Page</u>
1	Comparison Between the Desired and Obtained Angular Widths of the Runways in the Photographic Reproduction of the Computer Generated Images	27
2	ANOVA of Quotidian and Diurnal Variables and Cyclophoria as Measured by the Circle/Bar Test	34
3	ANOVA for the Effect of 0, 5 and 10 degree Convergence on Cyclophoria Measurements for 12 Selected Pilots	43
4	Correlations Between the Measures of Cyclophoria for the Screening Condition (0 degrees) and the 0, 5 and 10 degree Convergence. Experimental Conditions (for 12 Selected Pilots)	44
5	ANOVA for Effects of Image Cyclorotation on Cyclophoria as Measured With the ARC Test	52
6	The Mean Shifts in ARC Test Responses for + 2 degrees Image Cyclorotation Compared With the Responses on the Non-Cyclorotated (0 degrees) Condition	50
7	Effect of Image Cyclorotation on the Percentage of "High" Responses on the Runway Glideslope Perception Test	59
8	Runway Length and Frequency of "Higher" Responses as a Function of Cyclorotation	60
9	ANOVA for Results on Runway Perception Test Scored on Basis of Number "Correct"	64
10	Correlations Among Circle/Bar, ARC and Perception of Runway Plane Test Results	67

## INTRODUCTION

### BACKGROUND OF CYCLOPHORIA DEVELOPMENTS

Cyclophoria, or wheel-like torsion of the eye about the visual axis, has been described by early researchers of eye movements (Donders, 1847; Listing, 1854; Hering, 1868; and Landolt, 1876), and had become a popular subject of debate when Landolt's classical data appeared in von Helmholtz' "Treatise on Physiological Optics" in 1925. These early researchers found that with one eye occluded, when the direction of regard of the other eye is changed either in elevation, azimuth, or obliquity, both eyes appeared to suffer some degree of rotation about their optical axes. The difficulty in describing the complex eye movements contributed to a continuing controversy over "false" and "real" torsion until Glenn Fry, et al. (July and October 1947) proposed the adoption of a standard system of axes for analyzing eye movements which would simplify and, hopefully, resolve the confusion.

Although much of this early work dealt with monocular eye movements, it was recognized early on that cyclotorsional movement took place (in the interest of single binocular vision) when the horizontal lines or patterns, observed in a stereoscope, were rotated in opposite directions (Nagel, 1861; Helmholtz, 1865). In discussions of binocular cyclophoria, excyclotorsion is used to describe the condition in which the top of each eye rotates outward or temporally (positive values), and incyclotorsion to rotation of the top of the eyes inward or nasally (negative values). Cyclotorsion occurs normally under many binocular situations, acting to align the eyes to provide or maintain fusion and, in this regard, is referred to as "cyclofusional movement." Ogle (cited in Cibis, 1952) described the most salient characteristics of cyclofusional mechanisms by association with their early developers: "(1) Both eyes perform essentially equal, but opposite, cyclotorsional movements (Hoffman and Bieschowsky, [1900]); (2) Cyclofusional movements are limited entirely to the so-called Panum's fusional areas (Verhoeff [1934]); (3) The cyclofusional amplitude is unaffected by vertical divergence of the eyes enforced at the same time (Herzau, [1929]); (4) Cyclofusional movements vary in amount and reaction time with the individual subject."



These cyclofusional movements are distinguished from the naturally occurring monocular rotations which Listing's Law (Helmholtz, 1910) describes in the fact that the former are induced, that is, they are compensatory reactions. In experimental settings, these cyclofusional rotations are produced using similar patterns in a stereoscope or haploscope, or by the use of prism or mirror devices, in which the individual images to the eyes are rotated in opposite directions around their optical axes. After a short lag, the eyes follow the rotation of these images, with the amplitude of cyclotorsion being dependent upon the amount of detail in the patterns used (Ogle and Ellerbrock, 1946). A simple horizontal line produced the least amplitude while a complex print or photo resulted in attainment of the highest amplitudes.

Ogle and Ellerbrock noted that a single vertical line was not considered suitable for study since contrarotation of such images produced retinal disparities which, with no cyclotorsion of the eyes, made the line appear to incline toward or away from the observer. However, this phenomenon was used to advantage by Ogle and Ellerbrock to study the effects of various antagonistic stimulus patterns on cyclofusional movements. Also, it is one of the key concepts in the development of this proposal. Ogle and Ellerbrock, (1946), and later, Cibis (1952) in his study of "Faulty Depth Perception Caused by Cyclotorsion," used vertically separated points of light in their studies. Our interest in the effects of cyclophoria began quite coincidentally from results gathered in a quasi-depth perception test utilizing similar stimuli.

#### CYCLOPHORIA IN THE ARC TEST

Following some early work (Kraft and Anderson, 1973 a and b), the Boeing investigators, under contract with AFSC/AMRL, developed a test for the precision measurement of "chromostereopsis" (Vos, 1966), the illusion of differential depth experienced when stimuli of different hues, located in the fronto-parallel plane, are viewed binocularly (Anderson and Kraft, 1977). The stimuli for this test, the Alternating Ramp Chromostereopsis (ARC) test, consisted of photographs of a physical model board (figure 1), taken from left and right-eye positions, and presented in a Wottring Troposcope (stereoscope). The model board held rows of aluminum rods

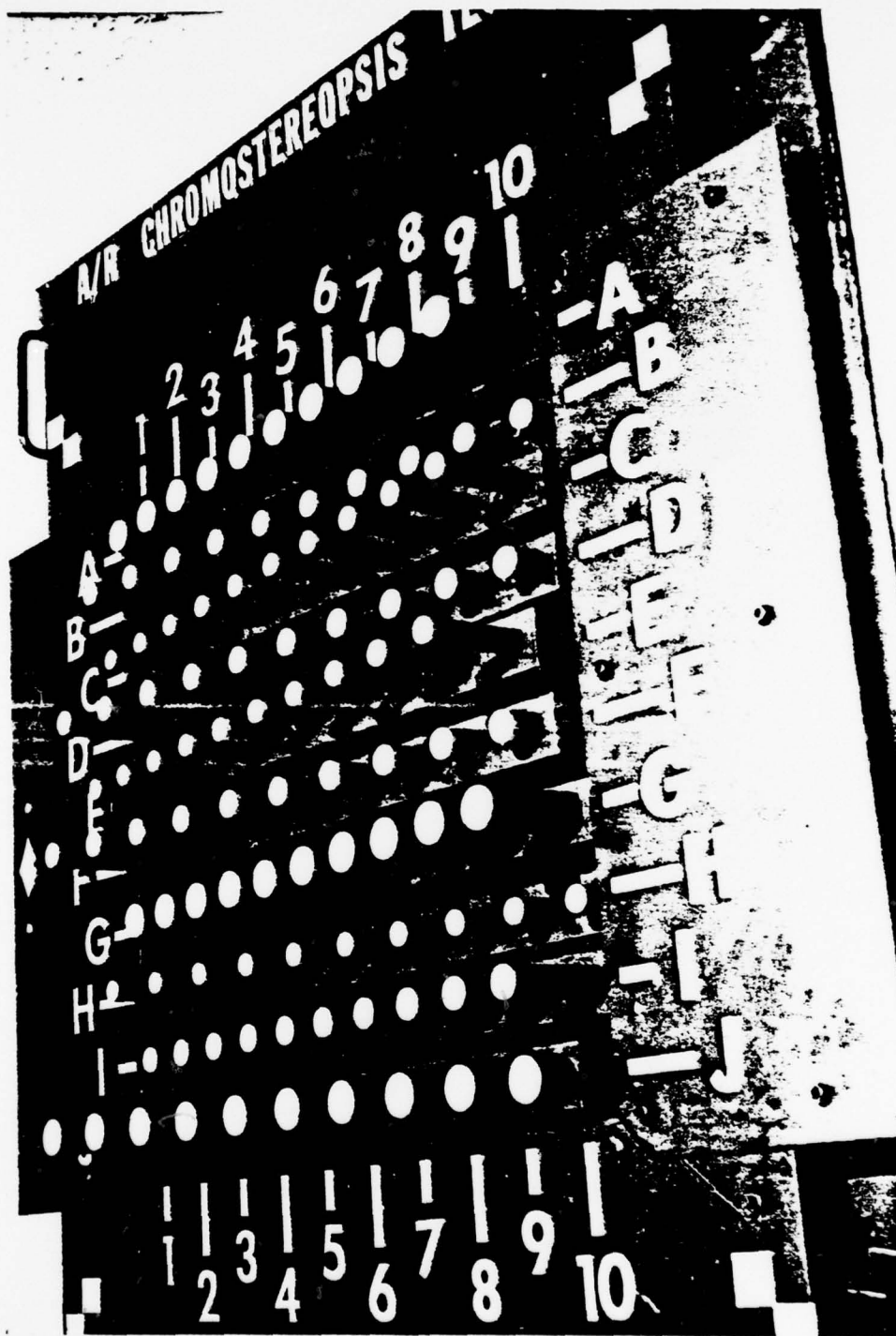

Figure 1. Model for ARC Test of Chromostereopsis

(of which only the polished end surfaces showed up in the photographs) which were of increasing lengths across the row, i.e., ordered in a stepwise linear ramp function. The direction of the ramp alternated from row to row so that when any two rows were compared, they would present a pair of alternating ramps of clear discs on a black background.

In presenting the test to the observer, the photographic transparencies of discs were transilluminated with alternating rows being saturated red or blue (an achromatic version was used as a control condition). The observer was asked to compare each pairing of rows (A with B, B with C, etc.) of different hues and opposing ramp function. The task was to locate the column position at which the two discs (one from each row) appeared to be equidistant from the observer. This point was called the "crossover" point and could fall at, or between, any column from #2 to #9.

The degree of chromostereopsis appears to be normally distributed in the observer population, with over 200 arc seconds of hue-induced disparity having been measured between extreme "red-advancing" and "blue-advancing" observers (Anderson and Kraft, 1977). For an observer with some degree of chromostereopsis, the crossover point will appear to shift from the null or true crossover position, either left or right, (depending upon the directions of the ramp functions and the observer's chromostereopsis) in direct proportion to the severity of the observer's chromostereopsis. The measure of the chromostereopsis effect is taken, then, as the difference between the responses to the achromatic and chromatic versions of the test. The response distribution of one observer on one of the six formats of the ARC test is given in figure 2.

A curious response pattern was noticed as prevalent in almost all observers, and can readily be seen in figure 2. The responses on the achromatic form of the test tended to follow a rhythmic pattern around the "null" position, and this pattern was duplicated with the chromatic stimuli. In searching for the cause of this anomaly, the one constancy over all conditions was that 11 of 12 observers responded as though they perceived the top row of the two they were comparing as being displaced further back than its true position, thus effecting a shift in the apparent crossover point. Since with each pair of rows, the direction

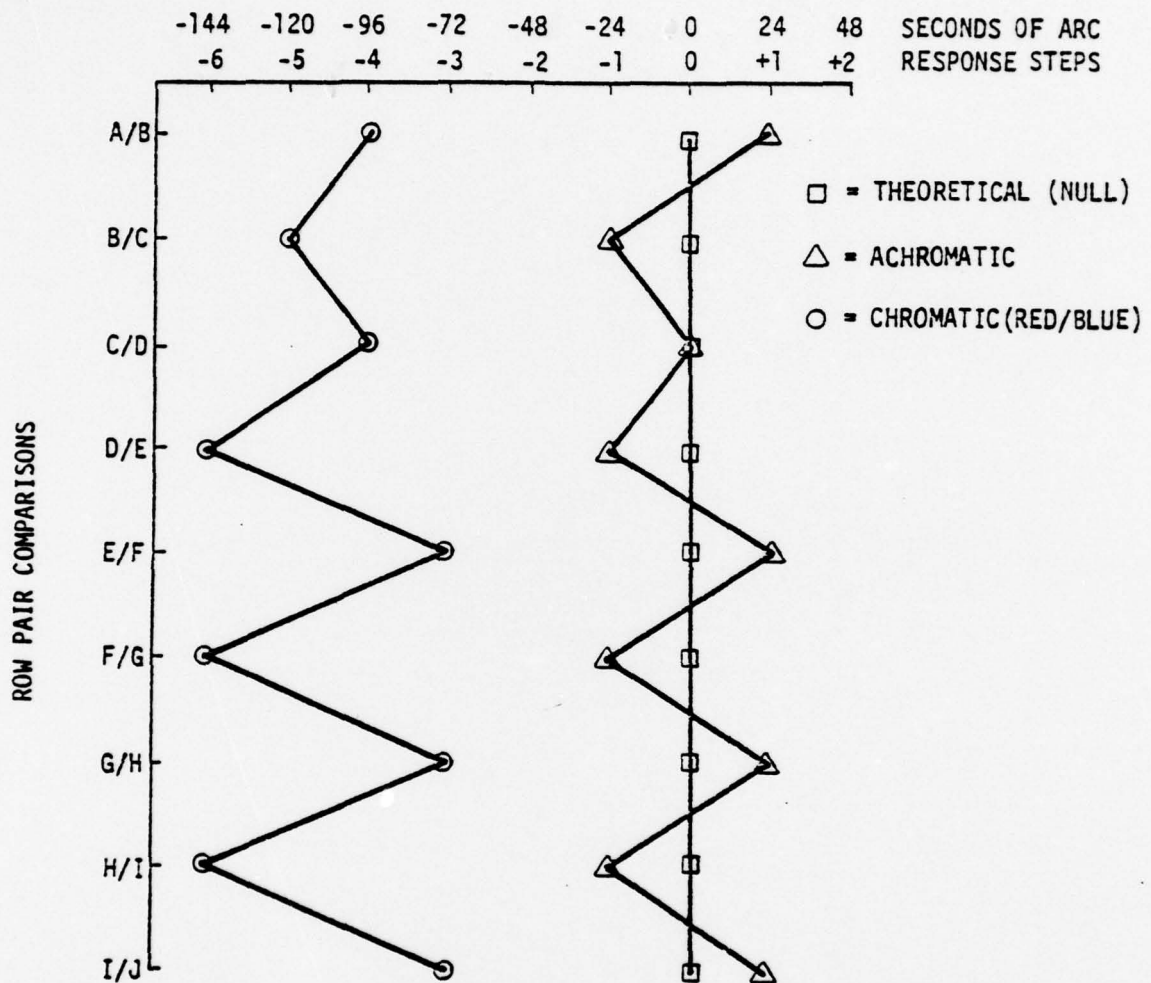

Figure 2. Response Distribution by Row Pairs for Observer #1 on Achromatic and Chromatic Versions of Format B of ARC Test



of the ramp reverses, this produced the rhythmic shift in the responses, rather than a unilateral shift. This phenomenon was termed the "layback" effect and was quite consistent over all formats of the test, although there was considerable individual variability in the strength of the shift. Figure 3 depicts the distribution of responses over all formats, with the average shift for 648 observer responses being 20.7 arc seconds. In searching for the cause of this shift it was discovered that the effect could be nullified, or even reversed, by contrarotation of the two images in the Troposcope. A surprising aspect of this procedure was the fact that, within a range of  $\pm$  two degrees of cyclorotation of the images, there was no significant tilt (layback) of the overall image, even though there was a perceived disparity shift between vertically adjacent discs of at least 40 arc seconds. If accumulated over the 10 rows of the format (a visual angle of about eight degrees), this would amount to a disparity from the vertical plane of over 360 arc seconds. Yet tilt of the overall image was not noticed. Thus, this appears to be a striking example of incomplete cyclofusional movement, in which the cycloincongruity between images and eye meridians was small enough to provide fusion and perceptual verticality, but large enough to produce significant disparity between the vertically separated discs.

There were three possible explanations for the results observed in the ARC test:

1. The Troposcope and/or the image mounts may have been misaligned, producing cyclorotated images and resulting in the cyclofusional eye movements.
2. The observers may have possessed varying amounts of cyclophoria which were not completely overcome by cyclofusional compulsions.
3. A combination of (1) and (2) may have been present.

Examination of the Troposcope indeed uncovered a small amount of rotational misalignment ( $< .5$  degrees) in one arm, though insufficient to



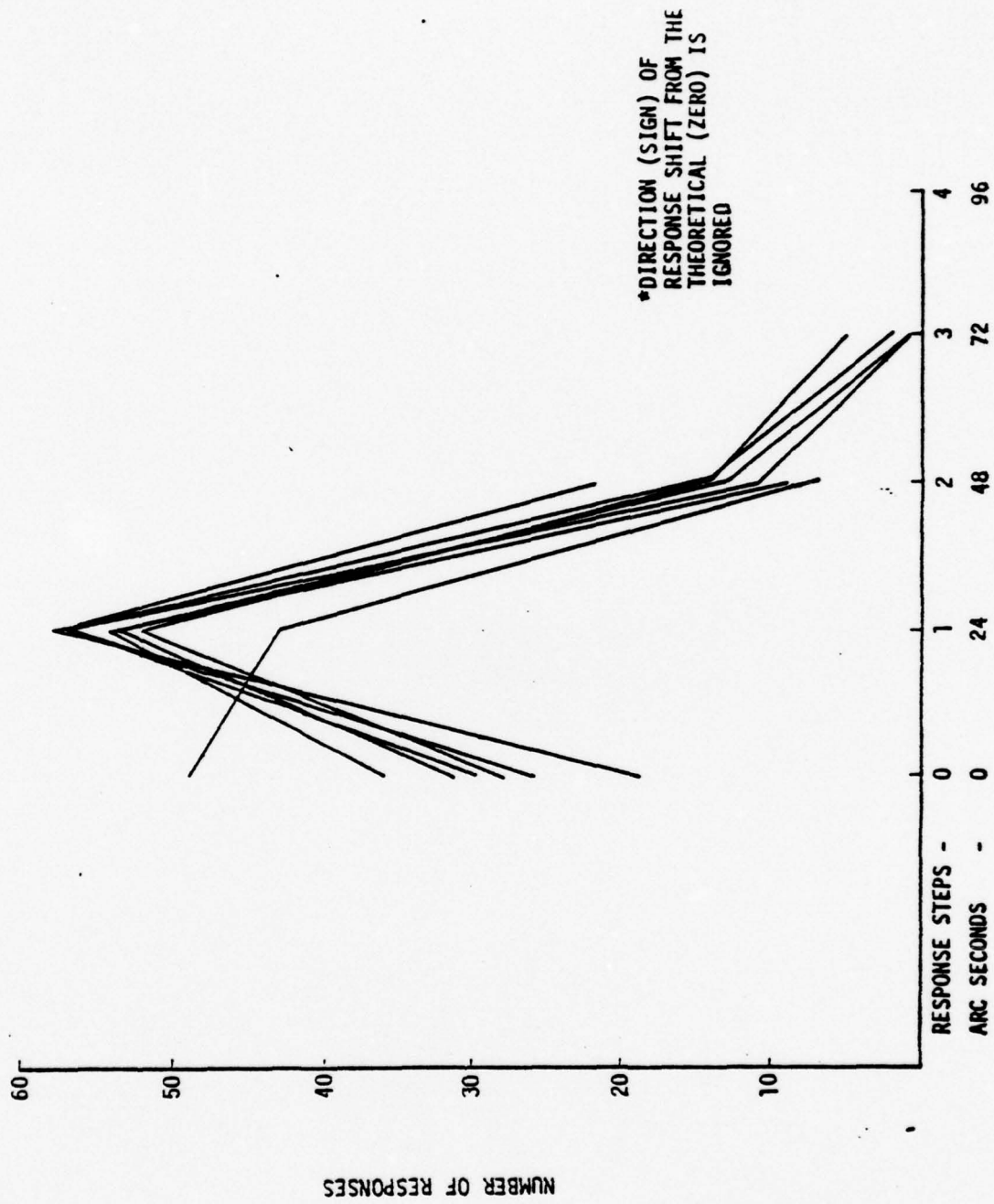

Figure 3. Distribution of Responses on Six Formats of Achromatic ARC Test\*

produce the effects shown. The individual differences of the observers supports the hypothesis that a portion of the induced shift was due to individual cyclophoria. It may well be that, just as there is a "resting state" of accommodation which falls inside relaxed (infinity) focus (Leibowitz and Owens, 1975), individuals may also exhibit a residual cyclophoria under viewing conditions in which cyclofusional stimuli are minimal or absent.

#### THE PROBLEM OF RUNWAY PLANE PERCEPTION

The significance of individual differences in the cyclophoria resting state lies in its potential effect in situations where there are vertically oriented stimuli with insufficient field pattern to completely control cyclotorsional eye movements. One such situation faces the pilot making an approach to a runway either at night, or with other homogeneous field conditions (snow-covered ground, over water, in fog, etc.). Under such conditions, there are minimal distance and altitude visual cues available to the pilot. Since runway dimensions vary a great deal, the shape of the runway itself cannot be reliably used as an indicator of altitude or distance, although the rate of change in the shape (when correlated with approach velocity) may be more useful. In a preliminary laboratory study, Hasbrook (1975) found that "professional pilot estimates of flight path angle (using only computer-generated runway outlines) showed a wide variation in judgment."

The significance of this problem may be extended to situations in which cyclophoria may interact with other cyclotorsional (induced) effects. Convergence of the eyes and some degrees of depression of the line of sight induce larger cyclorotations than the resting state. Pilots in making instrument letdowns, through overcast skies, spend the greatest amount of time on the ADI. This instrument, which provides both altitude and relative position on the azimuth and glide slope, is 28 inches from their eyes and 35 degrees below the horizontal line of sight. Therefore with a head tilt of 15 degrees, a visual depression of 10 degrees and a convergence of five degrees to read this instrument the cyclotorsional influence is generally to increase excyclorotation. The additional rotation of the eyes will be dissipated with time. As the

pilot looks up to gain a visual reference to the runway, however, initial momentary perception of the aircraft's height may differ from the subsequent judgments. If such an influence exists, a possible contribution to the "duck under" phenomenon may exist in cyclorotation of the eyes.

#### Night Visual Approach Research and Runway Visual Angle

A series of 16 experimental investigations conducted under the auspices of the Military Aircraft Systems Division of Boeing and the Boeing Commercial Aiplane Company led to the development and testing of the effect of runway visual angle on approach performance. The impetus for this research came from four crashes of the 727-100 series as they were first introduced into airline operations. The four accidents had a commonality that really described the research problem. They were all approaches over darkness toward large well-lighted cities, under weather conditions where the pilot could clearly see the city lights but not necessarily a horizon. In every case, the pilot called thru to the tower and got permission to change from instrument flight rules to visual flight rules for the approach and landing phase of the flights. In three of the four instances, there was no recognition that the aircraft was exceedingly low or descending too rapidly.

The hypothesis tested was that if the light patterns were truly random, they would not adequately describe (in a visual sense) terrain that had hills or slopes, and therefore the visually filled space between the nearest lights and the farthest lights would appear to be a flat plane. If the runway and the airport were on the near side of the light pattern, the pilots could descend to too low an altitude at some distance from the runway in an attempt to make an upward sloping terrain appear flat. The visual angle under consideration is the inclusive angle from the nearest lights to the pilot's eye and thence to the farthest light along the flight path of the aircraft. If the pilot were flying a fixed-wing airplane, maintaining his altitude and overflying the city, this visual angle will increase until the first lights begin to pass underneath the glare shield. If however, he were flying a helicopter, and maintained his distance but descended vertically, this visual angle decreases as a function of the lower altitude. So on a fixed wing



approach and descent, these two factors, an increasing angle due to the approach and a decrease of the angle by lowering the altitude, could approximate a null, and an excessive descent rate might not be recognized by the pilot if he were flying over an area with no lights beneath the aircraft. The experimental findings confirmed the hypothesis that it is the visual angle that the pilots use in making approaches from 4-1/2 miles out or beyond. An unexpected result was that in the control conditions, it was determined that the pilots flew a slightly curved path which is really an arc of a circle whose center is somewhat above the flight path when, in fact, they think they are making a straight-in approach.

#### Perception of "Runway" Plane in Aircraft Carrier Approaches

It was some years later than Wulfeck, Queen and Kitz (1974) in investigating the toed-in versus parallel lighting of aircraft carrier decks, determined that observers who were asked to report when the ship was horizontal, made the same kind of discriminations as the pilots made in the earlier Kraft and Elworth investigations. The Wulfeck et al. study differed in two respects. The distances they studied were .5, 1.0, and 1.5 miles out. In none of these cases did they have a dynamic simulation in which the aircraft moved toward the carrier. Of most interest is the fact that these two studies found that visual discrimination of the horizontalness of the forward plane can be determined within  $\pm$  one minute of arc. Whether cyclophoria can have a significant impact on the accuracy of these judgments is the subject of this proposal.

In a follow-on study to the night visual approach investigations of 1968, Drs. Elworth and Kraft investigated whether runways of different lengths and different widths, combined with different slopes, would modulate pilot performance when the city illuminances were low (Kraft and Elworth, 1969). In figure 4 it will be noted that the final visual angles at 4.5 miles from touchdown were within two arc minutes of each other. This is particularly interesting when one looks at the variations of these runways. The 10,000 ft. long, 300 ft. wide runway on flat terrain had the highest final altitude and the largest standard deviation. The 7,500 ft. runway with a width of 200 feet, and with a 1.5

GENERATED ALTITUDE

CONTIGUOUS LIGHT PATTERN

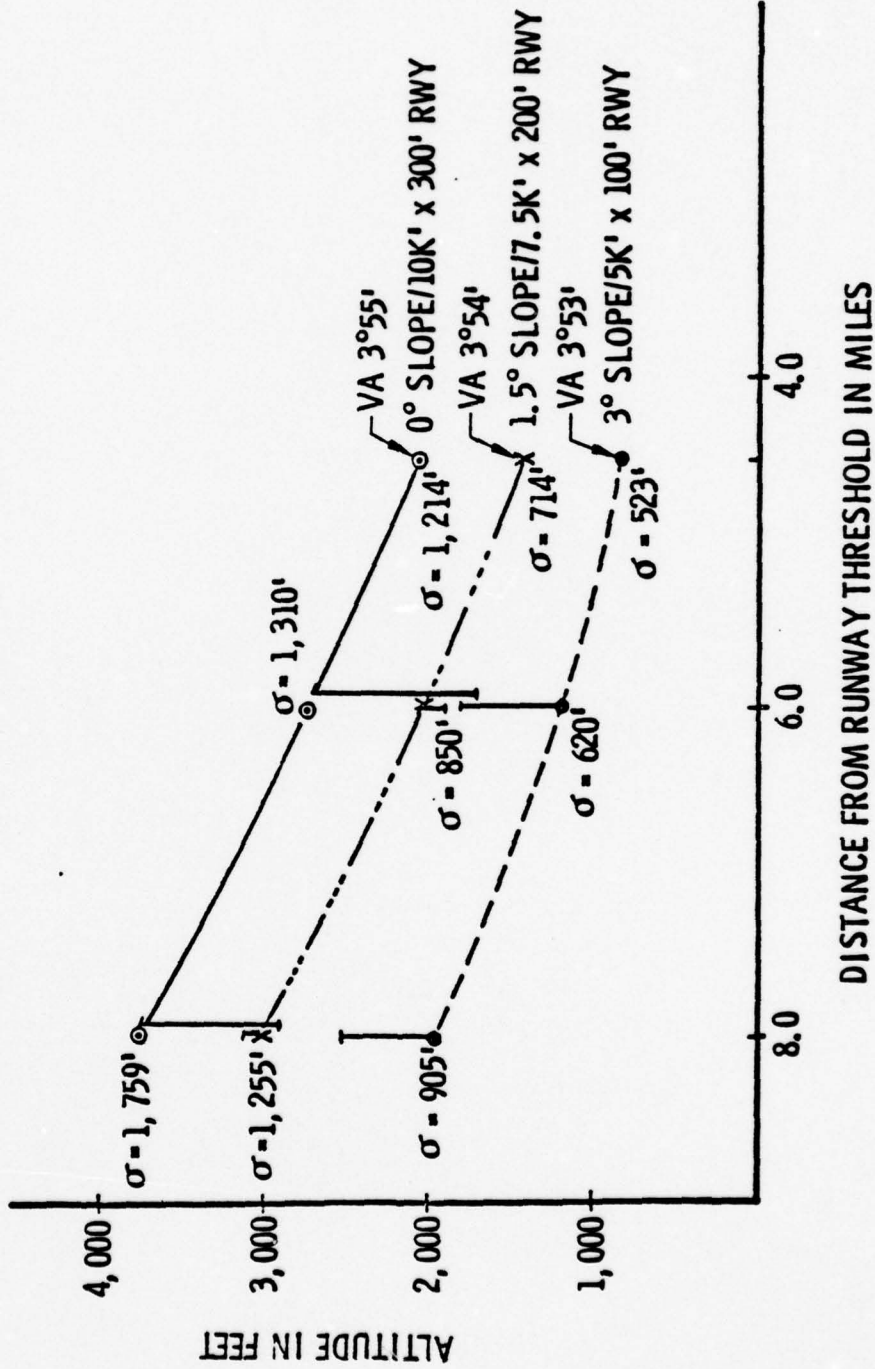

Figure 4. Generated and Estimated Altitudes for Approaches to Contiguous City Flight Pattern as a Function of Topography and Runways

degree upward slope, produced the same visual angle with an intermediate altitude and a standard deviation of 714 feet. The smallest runway, 5,000 ft. long by 100 ft. wide, which was represented on a three degree slope, had the lowest final altitude and a standard deviation of 523 feet. These final altitudes were generated by experienced pilots flying to the three visual scenes without the aid of altimetry. At this distance the relative motion cue would not have been operating and the pilots were flying to make the forward scene appear to be flat. The explanation for the variation in standard deviation may be that the pilots fly in a more relaxed fashion to the most familiar, long, flat runway (10k x 300 ft) and become much more precise in flying to difficult and less familiar runways.

#### DEVELOPMENT OF THE CIRCLE/BAR CYCLOPHORIA TEST

Under these conditions, the pilot may be susceptible to any residual cyclophoria compulsion. Since the runway image is at optical infinity and identical (assuming no windshield aberration) to both eyes, a slight excyclophoria would act to add false stereo effect to the runway image, tilting the top (far end of runway) forward and the bottom (threshold end) back. Accompanying this effect would be an altered perception of the runway plane, proportional to the amount of induced tilt. To test the phenomenon of residual cyclophoria, the Boeing investigators developed the Circle/Bar Cyclophoria test. The stimulus format for the Circle/Bar Cyclophoria test is shown in figure 5 (identical images are presented to both eyes in the Troposcope). With the Troposcope set at zero degrees convergence, at optical infinity, and adjusted for the observer's interpupillary distance, the image holders can be cyclorotated. With the excyclorotation, the fused circle remains in the fronto-parallel plane while the vertical bar appears to tilt back away from the observer at the top (behind the circle), and toward the observer at the bottom (in front of the circle). The task is to line up the bar with the circle by adjusting the rotation of the images. The error between where the observer aligns the images (average of the two images) and the true vertical (no image rotation) is taken as a measure of the observer's "free field" or "resting point" cyclophoria.



Figure 5. Format of the Circle/Bar  
Cyclophoria Test



## EXPERIMENTAL APPLICATION OF THE CIRCLE/BAR TEST

In preliminary efforts to experimentally test the effect of cyclophoria on pilot performance, the Boeing investigators included this test in two recent investigations. In a Pilot Acceptance and Performance Evaluation of the visual system for the flight crew training simulators at Boeing, the new General Electric Compuscene was the equipment under evaluation (Kraft, Elworth, and Anderson, 1976). One of the aspects that was not included in the publication was the use of the Circle/Bar cyclophoria test as a predictor of which pilots flew highest against the night scene. It was found that the cyclorotation test, combined with a form of the duochrome test of the size of the chromatic interval of the eye, and the ARC test as a measure of chromostereopsis, gave a rank order correlation of .85 between this combined ranking and the 747 pilots' altitude over threshold and at .6 nautical miles from touchdown. This data encouraged the Boeing investigators to extend the same kind of testing for the pilots used in a windshield quality evaluation study done for the Air Force/AMRL (Kraft, Anderson, Elworth, and Larry, 1977).

This investigation was primarily a study of the effects of four levels of windshield distortions on pilot performance in making approaches/landings. The Circle/Bar test was given the eight participating pilots, and the results used to predict approach altitude at 8220' from the visual touchdown point. The eight pilots differed as to how much cyclorotation was necessary to make the fronto-parallel plane appear vertical. The proportional amount of cyclorotation correction was related to the height these pilots flew with the "good" quality windscreen at 8220' from the touchdown mark. The relationship was less strong at near and greater distances; at 8220' distance, the correlation is .46, while at 16,560', the  $r = .39$ . The correlation would probably be highest at distances where movement parallax did not contribute and where the runway details were sufficient to judge the ground plane projection.

The windscreen quality attenuations decreased the correlation, but not in direct proportion to their scaled quality. The negative sign of these correlations was a product of how the authors ordered the cyclo-



rotation values, greatest negative (top back) value to the greatest plus (top forward) value. Perception of the frontal plane with the top forward was associated with flying lower at 8220' from touchdown.

Figure 6 shows the regression prediction of approach altitude from the cyclophoria data for day versus night approaches and for the different windshield quality conditions. Looking at night approaches only, for all windscreens at this distance, the correlation rises to .72. Prediction for the day scene only with all windscreen conditions decreases to .11. The direction of the perceived tipping of the frontal-parallel plane is common with that of upward sloping terrain, and they have a mutual effect on night visual approaches. If the top of the fronto-parallel plane is perceived nearer the pilot, and he required, in the Circle/Bar test in the Troposcope, clockwise rotation of the right-eye image and counterclockwise rotation of the left-eye image to correct for his perception, he will fly lower. This is equivalent to his seeing the ground plane with the most distant objects on higher ground.

These data suggested a relationship that the Life Sciences Directorate of the Air Force Office of Scientific Research asked the Boeing Aerospace Company to investigate.

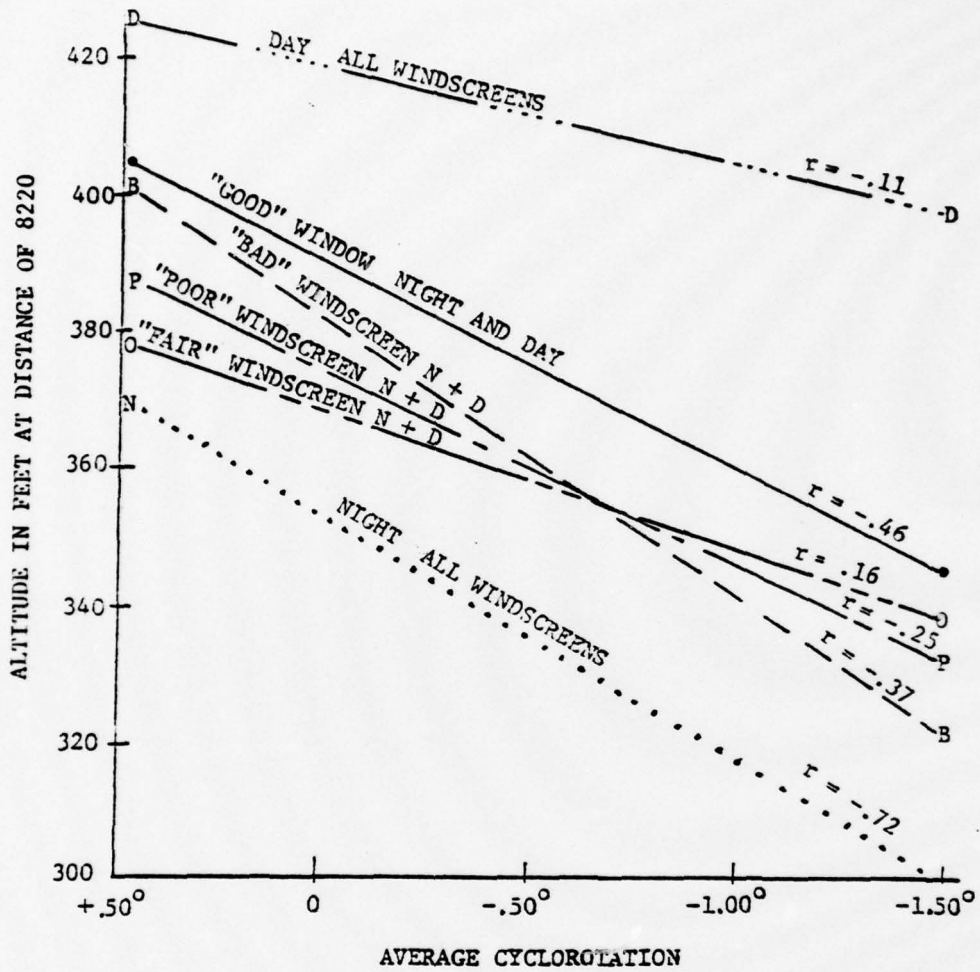

Figure 6. Prediction of Altitude at 8220' Distance From Pilot's Perception of Verticality In the Fronto-Parallel Plane

## THE PROBLEM

The problem was to determine if perception of the runway plane by pilots was associated with the cyclophoric resting state of the eyes. In the course of this activity to gain an estimate of the distribution of cyclophoria among pilots, the reliability of the measure, and the variability among and within days. To develop a set of stimuli useful in a stereoscopic display device that might be used in screening a population for cyclophoria. To develop and test procedures to use these stimuli as visual performance tests. To provide statistical estimates of the quality of the data collected, make theoretical interpretation of the results, recommend possible applications.

The problem was not to conduct a definitive study, but to establish a reasonable experimental data base to answer the question of whether cyclophoria might be involved with pilot training, perceptual differences and air safety. If the evidence was positive to provide USAF/OSR with recommendations for continued research. The long term goal of such recommendations is to provide a step wise assessment of the importance cyclophoria among the other perceptual information sources for pilots' performance in flight, factors which modulate cyclophoria, the role of training in such modulation and the transfer of such training to operational flight performance.

## EQUIPMENT AND STIMULUS MATERIALS

### TROPSCOPE MODIFICATION FOR THE MEASUREMENT OF CYCLOPHORIA

Prior work in measurement of cyclophoria indicated a need for measurement of greater precision, a device that was observer controlled, and, for the experimenter, a digital readout. An American Optical Wottering Troposcope Model Number 13300, Serial Number V1195 was modified for this purpose. This instrument was loaned to the contract by Washington State University.

The modifications began with powering the rotatable slide holder and lamp house assembly. A geared arc was attached to the lamp house. The rotation was driven by a direct drive from two small electric motors, one for each of the lamp houses. The geared arcs transmitted the rotation directly to an idler gear which activated a smaller gear providing a three to one gain in rotation to two precision potentiometers, one assembly for each lamp house. Conventional Boston gears were used for this application and an anti-backlash control was imposed by weighed pulley arrangements.

The direction and speed of the motors could be controlled by either the observer or the experimenter through a pair of joy sticks. Control could be switched to either one of the joy sticks, but not both simultaneously. When the observer had the control, both lamp houses moved simultaneously in counterrotating directions. The experimenter could select which lamp house he could control or have both of them together. He also had control of the gain for each. The experimenter's joy stick was primarily for initial setting or to balance the two settings whenever a disparity in position occurred.

The readouts for the potentiometer were fed through an amplification system so that their product was on display to the experimenter on two Intersil Evaluation Kits, Model ICL 7106. This provided digital readouts with a range of plus or minus 1999 units. The gains were set so that these units were equivalent to 21 arc seconds or .0058 of a degree.



### Alignment and Calibration

Two identical precision slides were made on glass plates of 3-1/4 by 4 inch size representing a circle of 43 millimeters inside diameter and having vertical and horizontal double cross hairs. These were made with a Borrowdale camera with a 12:1 reduction from the original drawings. The original drawings were done to specifications by a computer controlled coordinatograph with a precision of one thousandths of an inch. The glass plate reproductions were measured in the Mann Comparator to a accuracy of 0.001 millimeter. Assurances that the glass plate would rest in a vertical plane within the lamp housing was obtained by special grinding of the bottom edge of the slide. This improved edge was used as a reference for measuring the horizontal and verticalness of the precision lines within the image.

The two identical slides were placed, one in each lamp house, and the Troposcope positioned such that it would cast an image on the vertical wall with a magnification of 11.6 times the original size of the slide. This placed the image of the outer ring of the slides just outside the tick mark of a compass rose which had been enlarged to 49.8 centimeters and mounted on the wall. This precision compass rose was scaled in half degree units. The center of the compass rose was marked by cross hairs and two other cross hairs were located in a horizontal plane 1.25 inches to the right and left of the central cross hair. The purpose of the two ancillary crosshairs was to assure the alignment of parallelness of the eye pieces of the Troposcope with the zero point on the convergence scale. If the eye pieces of the Troposcope were set at 2-1/2 inches of separation, then the images should fall on these two crosshairs which were also separated by 2-1/2 inches. This was the calibration of the zero convergence reference point as well as the interpupillary distance setting. These two scales interact in the Troposcope design.

For the alignment of the rotation of the lamp houses, first the right eye image was moved over so that the crosshairs were on the center of the compass rose. Then, with the power units and the method of adjustment, the zero point was obtained when the horizontal bar in the projected image matched the 270-90 degree axis of the compass rose.

Ten trials by a practiced observer were used to get the zero point for the image and to set the zero readings on the digital readout. The same thing was repeated to establish the left eye reference.

The product of the calibration gave us a constant error of 0.595 arc minutes or 0.00135 degree. The variable error was somewhat larger. The left eye was 2.45 arc minutes or 0.0012 of a degree. The right eye was 3.91 arc minutes or 0.0208 of a degree.

#### MODIFICATION OF SECOND TROPOSCOPE

To display the runway and ARC test stimuli with  $\pm 2^\circ$  and zero rotations with both speed and accuracy it was necessary to modify a second Troposcope. An American Optical Company Troposcope, Model 13300, Serial Number AJ 1872, loaned to the contract by Washington State University was used to provide this display.

The instrument was mounted on a wooden 16x14x1 inch base to gain a rigid and fixed position of the instrument in three coordinates. Attached to this base 14 inches behind the eye pieces were two vertical aluminum bar stock (1/8x1x13 inches) posts. Attached to each of these posts were two eccentrically mounted disks that served as adjustable stops. Centered between these vertically displaced stops was a registration pin. Contacting these three physical references were twelve inch levers attached to each lamp house of the Troposcope. The center of rotation was 10.5" from the stops. Therefore 0.18" of motion up or down from the center registration pin was equivalent to  $\pm$  one degree of rotation of the lamp house.

The experimenter standing behind the Troposcope could move these two 12 inch levers simultaneously up, down, or to center to effect the  $\pm 2^\circ$  and  $0^\circ$  of rotation desired. The precision of positioning was fixed by the alignment pin for the 'zero' rotation, and the stops or physical barriers to upward and downward motion. The observer could not tell the extent or direction of the motion of the lamp house's drive mechanisms nor the experimenter's movements as these were shielded from his view by

foam-core panels cut to obstruct his view beyond the protruding eye pieces.

The rotational movements of the lamp houses were always made in the four second dark phase between the three second exposures of the "standard" and the "variable" members of the paired presentations. These timed intervals were controlled by a Tandem Recycling Timer, Type A, made by the Industrial Timer Corporation of Newark, N. J. The three second 'on' phase half of this interval timer controlled the power to the lamp filaments in each lamp house.

This arrangement of controls, timer and Troposcope allowed the 72 pair presentations to be completed in an elapsed presentation time of 14 minutes, with five minutes for instructions and two sessions of seven minutes each; the total test could be administered in 20 minutes.

The calibration of the instrument as to whether the zero position was a true vertical, and the two degree rotations were precisely the expected value was accomplished with the same technique used for the powered Troposcope. The precision alignment slides were placed in the lamp houses and back projected on to a wall-mounted compass rose. The two enlarged (11.6x) images were centered, then the three positions, 0, + 1, and -1 degree were checked against the large wall-mounted reference. The zero point was first set and the 12 inch levers were then locked in position. Following this, the maximum movement stops were rotated on their eccentrics until the desired position was obtained; then they were locked against further rotation.

#### ALTERNATIVE STIMULI FOR THE CIRCLE/BAR TEST

The Circle/Bar Test used in our prior experiments had been considered an original design by the authors, and had not been subjected to a systematic program of optimization. Therefore, some comparative knowledge about its merits was needed. The literature search disclosed that George Harker had used a very similar design with the same logic 19 years earlier. Harker wrote, "The circle provides stimulation for



lateral and vertical fusion, but not for cyclotorsional fusion." Harker also used a variation in that he always had a central dot about which he rotated the stimuli. This was one of the considerations that we wanted to include in our alternative stimuli.

The cyclophoria test patterns used in this investigation are included in figure 7. They were four in number with two alternatives, without and with a center dot. The number one pattern, which was titled "two dots with triple circle" was planned to test whether the cyclophoria estimates would be of equal magnitude when the two movable stimuli were very close to the fovea. The number two design was a plain bar with a circle. We had noticed in some of our observations that the segments beyond the outside edge of the circle did not always appear to contribute to precise judgments, thus this alternative. The third design was the circle bar with a short segment, the short segment being a 26 minute extension of the vertical bar beyond the perimeter of the outside edge of the circle. The fourth design was a circle bar with a long segment. The segment was about one degree. The outside dimensions ranged from 8.8 degrees to 10.8 degrees (see figure 7). Therefore, all designs fell within the anatomical area of the parafovea. The center dot in this alternative was about .29 degrees (about 17 arc minutes) as was the width of the clear segments in these drawings.

Each of these was a clear figure in a dark field, printed on glass plates 3-3/4 by 4 inches in size, having very high contrast, the background varying from the figure by a gamma of five. They were copied down from a 12 times larger figure constructed on the coordinatograph. Calibration measurements to one thousandth of a millimeter were completed on the Mann Comparator and the rotation corrections ranged from zero to 2.82 arc minutes. These constant errors were reduced to zero by subtracting or adding constants to the experimentally obtained data.

The work of George Gogel indicated that we should be concerned with the adjacency principle. We therefore attempted to maintain similar separations between the movable stimuli and the circle's edge. In all but the two dot test, the minimum of the adjacency was 8.86 arc minutes. For the two dot test, the smallest adjacency was 4.22 arc minutes.



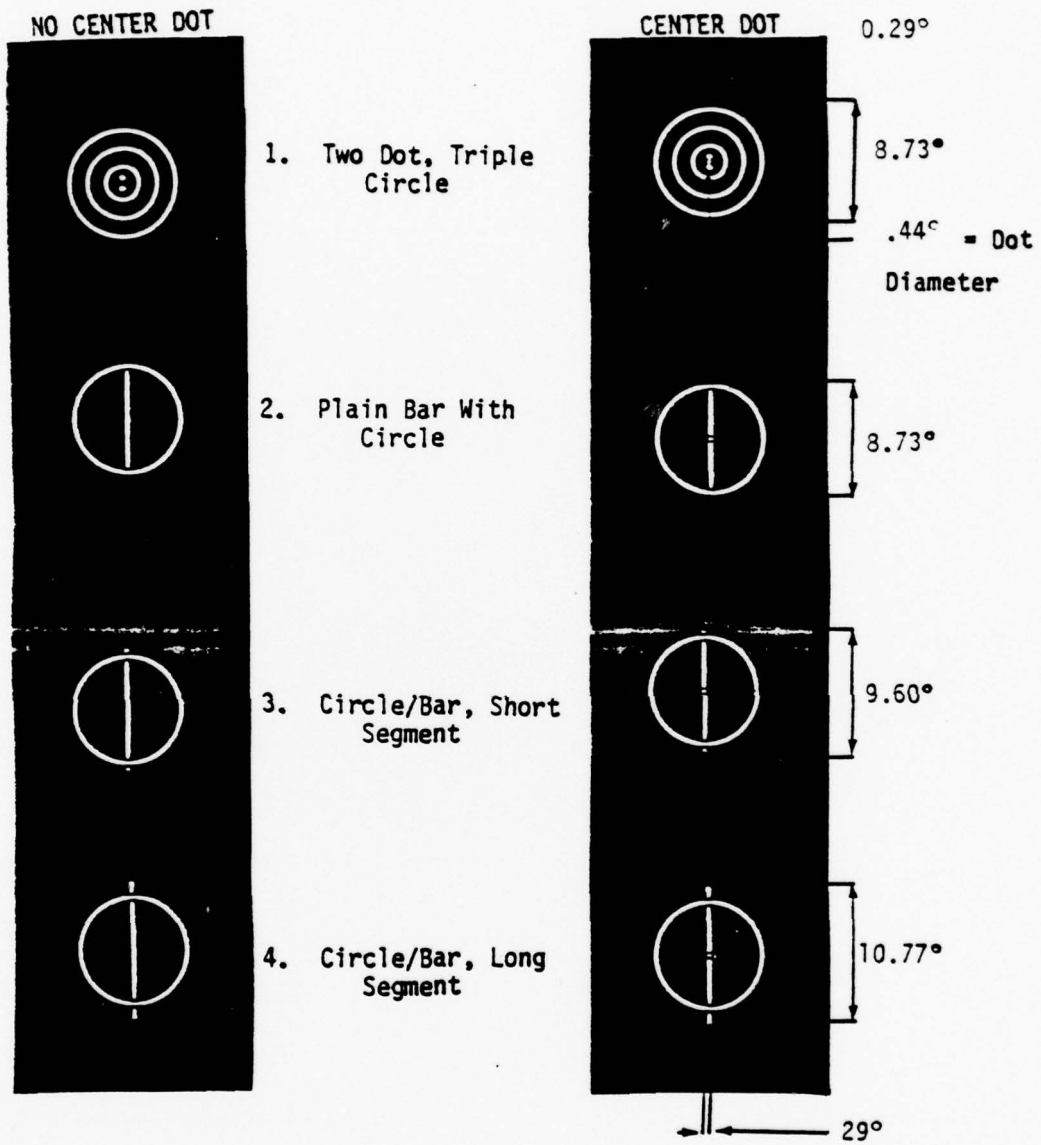

Figure 7: Cyclophoria Test Patterns

## PREPARATION OF THE RUNWAY PHOTOGRAPHIC STIMULUS MATERIALS

To test the pilot's perception of the horizontal forward plane, a series of photographs were made of the General Electric Compuscene's computer-generated image. Three of five available runways were chosen; 321 on the MWH or Moses Lake data base, which is 13,500 feet long and 300 feet wide. This represents a B-52 runway on flat topography with only two buildings on the left side of the runway. The second choice was Boeing Field International with its 200 foot wide, 10,000 foot long runway and the approach to runway 13R. This represents a runway with frequent buildings on both sides and a good deal of ground detail. The third runway was Yakima, 270, with a 150 foot width and 6,607 feet in length, viewed on a green field with two buildings on the right.

The decision was to portray each of these runways with the same visual angle representing the width at the threshold of the runway. To select the visual angle, the size of a 200 foot wide runway as viewed from 3,000 feet from touchdown marker and 157 feet of altitude was computed. This is equivalent to a three degree glide slope angle that originates from the touchdown mark 1,000 feet beyond the threshold of the runway and a visual angle of 5.6932 degrees. Each of the other runways then were made to match this visual angle by selecting a slant range that would depict a runway threshold width of 5.69 degrees. The wider runway at Moses Lake was therefore depicted at a greater distance, but still on the three degree glide slope. Yakima, at a shorter distance because of its 150 foot wide runway, still maintained a three degree glide slope from the 1,000 foot mark.

Colored transparencies of a minimum of 55.5mm in width and height were required to provide a 15 degree field of view in the Troposcope. Duplicate images for the right and left eyes were made. One of the image generators of the Compuscene was used to display the image on the 25" color cathode ray tube in the visual control center. A 4 x 5 Crown Graphic camera loaded with high speed 2-1/4 x 2-1/4 Ektachrome 400 color film was positioned in front of the CRT. The distance from the cathode ray tube was such that the 200 foot width of the Boeing Field runway

would subtend the same angular size in the Troposcope as it would in the real world from the approach distance selected. This meant that the CGI image was reproduced at about 20.63mm in width for the 200 foot width of the BFI runway 13. The image size was measured with precision calipers on the ground glass in the Crown Graphic.

Time exposures longer than 30 seconds were chosen to avoid partial refresh or frame rate problems. The exposure was measured with a Weston Master II area meter which gave exposure values for the day scenes of 1/5 of a second at f/11. (effective aperture of f/16.) and for the night scene 1/2 second at f/11. Positioning of the CGI scene was done from prior calculations (see Appendix 1) by introducing them into the computer-associated typewriter. The computer inputs were the x and y values in feet representing true north, south and west positions, a true heading of the runway (not the magnetic heading) and inserting the altitude that had been calculated for the three degree slope.

For each of the runways a day and night scene were taken. In every case the image was reproduced with almost no atmospheric attenuation. The visibility was 315 miles and the RVR was 240,000 feet. This provided for the pilot an extended visual projection of the horizontal plane in the imagery. The end product was 24 transparencies representing two copies each of 12 scenes; a night and day scene of three runways from two groups of distances.

These films were processed commercially without any effort to push the film and packaged in transparent sleeves so that measurements could be made on the imagery. Each of the images were subjected to photogrammetric measurements with a Mann Comparator that has the capability of reading in microns, or thousands of a millimeter. Measurements were made of the width at threshold, the far end and the length of the image of the runway. Five measurement trials were made for each of these values and the most homogeneous four were selected for computation of the averages. The linear distances in millimeters and the values divided by the focal length of the Troposcope give the tangent of the subtended angle.



Table 1 is a comparison between the desired and obtained angular widths of the runways in the photographic reproductions of the computer-generated images. The right hand columns give the percent error and the residual error. The residual error occurs when you subtract out a slight overall enlargement of the image due to too distant placement of the camera. The reader may note that the residual errors are generally below three percent with two exceptions. It probably is more meaningful to compare the sizes of these errors with the size (in percent) of one element of resolution in the CGI system. It is only in the case of one picture that the percent error exceeds that due to one element on the CGI system.

Reference also should be made to figure 8 which shows the pattern in terms of trapezoids of the three runways in each of the two series, the "3000" and "6000" foot series. This figure shows the relationship of the width at the far end and the length when the threshold width is a constant. One will notice that the largest pattern is from the smallest runway; Yakima for the 3000 series. The intermediate size of the image belongs to Moses Lake, (13,500 feet). The smallest image is for the 1000 foot runway of Boeing Field. This relationship does not hold for the "6000" foot distance. Here, the longest is Moses Lake (13,500 feet).

The relative shapes of these different runways become more homogeneous the greater the distance out the pilot is from the runway. This technique of making the stimulus material representative of a common three degree glide slope and a common threshold width gave us a representative range of distances out from the threshold of 1499 feet to 7499 feet. In terms of visual angle of the length of the runway, the range is from 2.2 to 4.5 degrees. The altitudes represented run from 131 feet to 446 feet.

For presentation, these slides were mounted in double glass slide mounts with a circular aperture such that the center of rotation could be the 1000 foot mark, or the point that a three degree glide slope would intercept the runway surface.

TABLE 1

Comparison Between the Desired and Obtained Angular Widths  
of the Runways in the Photographic Reproduction  
of the Computer Generated Images

	Theo- retical Std.	Empiri- cal Mea- surement	$\Delta$	Percent Error	Size* Error	Residual** Error
<u>Group 3 Near Width</u>						
BFI	5.6932°	5.7380°	0.0448°	0.79 %	0.8 %	0.01 %***
MWH	5.6929	5.8620	0.1691	3.00	3.0	0.00
YKM	5.6928	5.8290	0.1368	2.40	2.41	0.01
<u>Group 3 Far Width</u>						
BFI	0.9548°	0.9825°	0.0024°	2.52 %	0.8 %	1.72 %
MWH	1.0414	1.0580	0.0166	1.59	3.0	-1.40
YKM	1.05990	1.1546	0.0948	8.94	2.41	6.53
<u>Group 6 Near Width</u>						
BFI	2.2860°	2.2842°	0.0020°	-0.09 %	0.8 %	0.89 %
MWH	2.2856	2.4150	0.1294	5.66	3.0	2.66
YAK	2.2856	2.4047	0.1191	5.21	2.41	2.80
<u>Group 6 Far Width</u>						
BFI	0.7160°	0.7308°	0.0148°	2.07 %	0.8 %	1.27 %
MWH	0.8184	0.8106	0.0079	-0.96	3.0	-3.96
YKM	0.8295	0.8780	0.0485	5.85	2.41	2.35

\*Size error = The percent enlargement of the image above the desired size due to the camera to CRT distance error.

\*\*Residual Error = Percent error of width - size error or a correction due to enlargement of image by camera position.

\*\*\*One element resolution of CGI system in percent for each group;  
Group 3 Near = 0.88, Group 3 Far = 4.9; Group 6 Near = 2.19; Group 6 Far = 6.34.

LEGEND: MWH; L = 13,500', W = 300'  
BFI; L = 10,000', W = 200'  
YKM; L = 6,607', W = 150'

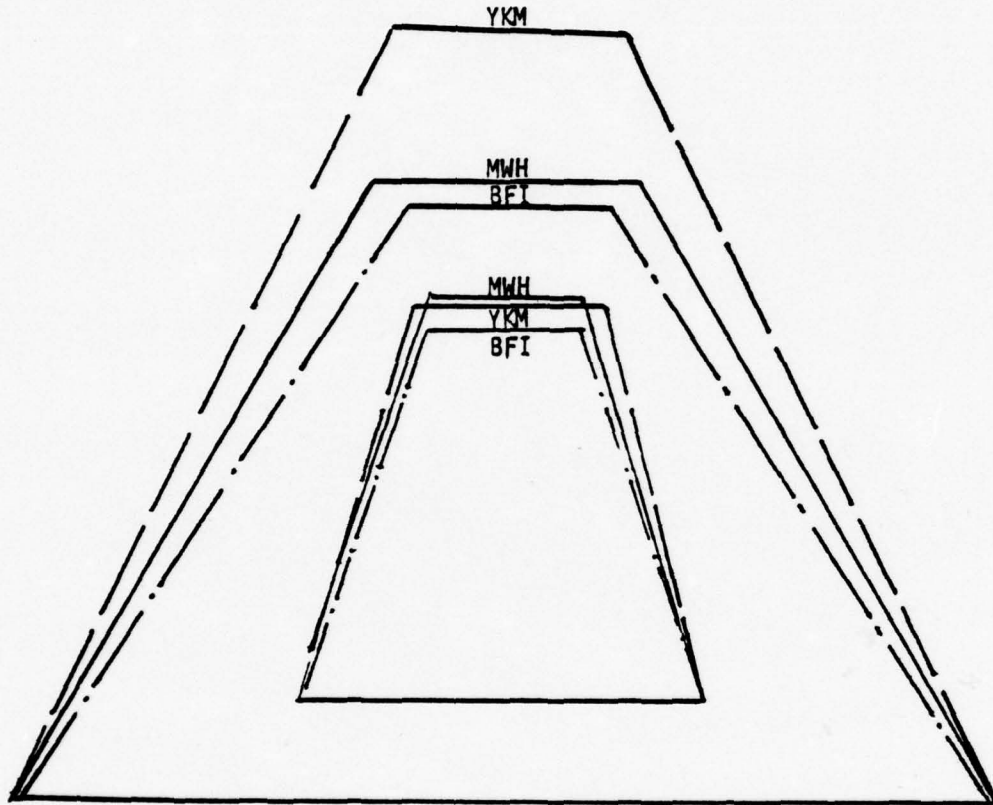

Three runways illustrated as trapezoids, matched as to the runway width at threshold ( $5.69^\circ$  and  $2.28^\circ$  of angular width), as viewed from  $3^\circ$  glide slope originating at the 1000' marker.

Figure 8 : Patterns of the Runways in the Pictorial Stimuli



## ALTERNATING RAMP CHROMOSTEREOPSIS (ARC) TEST STIMULI

A description of this test is included in the introduction and a picture of the model is figure 1. In figure 1 the ten ramps are identified with letters A through J. The number of responses per format (stereo pair) is nine; one for each of the nine adjacent row pairs. The ten columns and eight half values were available to make 18 possible responses per row.

The complete test has six different disk size and disparity formats. There are therefore 54 separate responses required of the observer. The disk size x disparity formats were photographed as masks on Kodalith achromatic film and were translighted with low color temperature tungsten illuminance in this application.

The six disk size x disparity formats were designed such that two subsets of three formats each are available and complete in themselves, either of which could be utilized in testing where time is a limiting factor. To keep testing time within a two hour period the subset with formats B, D and F were used.

The three stereoscopic pairs representing formats, B, D and F were printed on glass lantern slide plates. A special jig was made to register the unexposed plates for contact printing. The specific requirement of the reproduction of these masks is that no rotation was part of the visual stimulus. A number of copies were made until matched stereoscopic pairs of slides were obtained. Verification was obtained by photometric measurement with the Mann Comparator.

The stimulus subset used had a between disk relative separation of 23.7 arc seconds.

## PROCEDURE

### EVALUATION OF THE ALTERNATIVE CYCLOPHORIA STIMULI

It was anticipated that the eight alternative stimuli would probably give us different mean estimates of the cyclophoria and different variances among the individual trials. The procedure was to use four of the laboratory personnel as observers in preliminary tests of the advantages and disadvantages of these stimuli. Three of these four individuals had extensive experience with psychophysical investigations particularly in the field of vision. The fourth person had not participated in such experiments before.

The observer was seated before the Troposcope and the interpupillary distance was matched to the individual and the convergence was set to zero. The vertical centering of the exit pupil of the instrument to the center of the pupil of the eye was accomplished by the chin rest adjustment. The room illumination was lowered to approximately 1-1/2 foot-Lamberts. There was a combination of indirect fluorescent and tungsten illumination.

After a few adjustments to become familiar with the stimuli, the observer was asked to make 20 settings. He was asked to reset the stimuli above or below the null and then to proceed to return the alignment to the null, by using short bursts of rotation. The task was to align the moving stimuli, the dots or the bar, to be exactly in the same frontal parallel plane as the circle. Twenty trials could be generally accomplished within 20 to 30 minutes.

The results indicated that the average estimate of cyclophoria as a resting state by these different test patterns are shown in the following figure 9. Note that the smallest estimate was by design #4, the bar with the long segments. The largest estimate was with design #3, the circle bar with the short segments. These two designs also showed the greatest difference between the variations with and without the center dot. The most consistent estimate between those with and without the









	AVE.	AVERAGE VARIANCE		AVE.	AVERAGE VARIANCE
	83.5	528.2		70.2	751.6
	92.2	266.1		96.0	300.1
	122.1	407.6		86.5	616.7
	76.2	378.5		64.5	363.4
NO CENTER DOT			WITH CENTER DOT		

Figure 9: Estimates of Cyclophoria Resting State by Different Test Patterns



center dot was with the plain bar and circle design. However, the measure of reliability, the average variance, indicated the advisability of using the plain Circle/Bar test. This test, without the center dot had the lowest average variance, indicating that 68% of the trials would fall within plus or minus 14.3 arc minutes.

Comments from the observers indicated that they found it difficult to make a judgment of the null when there was a bar and a segment. It appeared that the interval of precise alignment was perceptually very narrow. That is, with the narrow separation between the end of the bar and the segment, the circle could be easily seen in front or behind the plane of the bar, but seldom perfectly aligned. All observers noted that they had a good deal of variability with the two dot test, and this was reflected in the much higher measure of variance. So the plain Circle/Bar stimuli, without a center dot, was chosen for the remainder of the experimental investigation.

#### Quotidian and Diurnal Variability of the Cyclophoria Resting State

To determine the amount of variability that might occur within one day and among days, three of the laboratory personnel were given the cyclophoria test in the morning and the afternoon for five consecutive days. Figure 10 shows that two tenths of a degree would encompass all of the variability that occurred among the days. For day two through day five, the variability for these observers would have been encompassed by four hundredths of a degree. In the diurnal variability, the morning and afternoon estimates of cyclophoria were all within two tenths of a degree.

An ANOVA (table 2) was completed to ascertain if the variables, time of day (T) or different days (D) or the differences among the observers (S) were significant. The mean differences among days or between times of day could be attributed to chance. The differences among the observers could be due to chance less than once in one thousand replications.

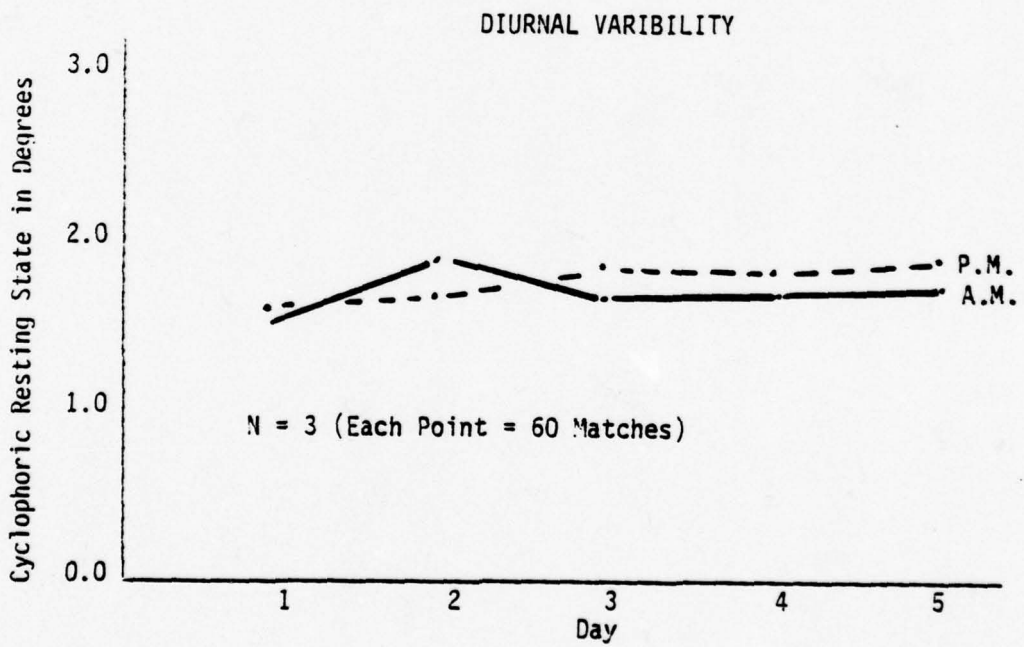
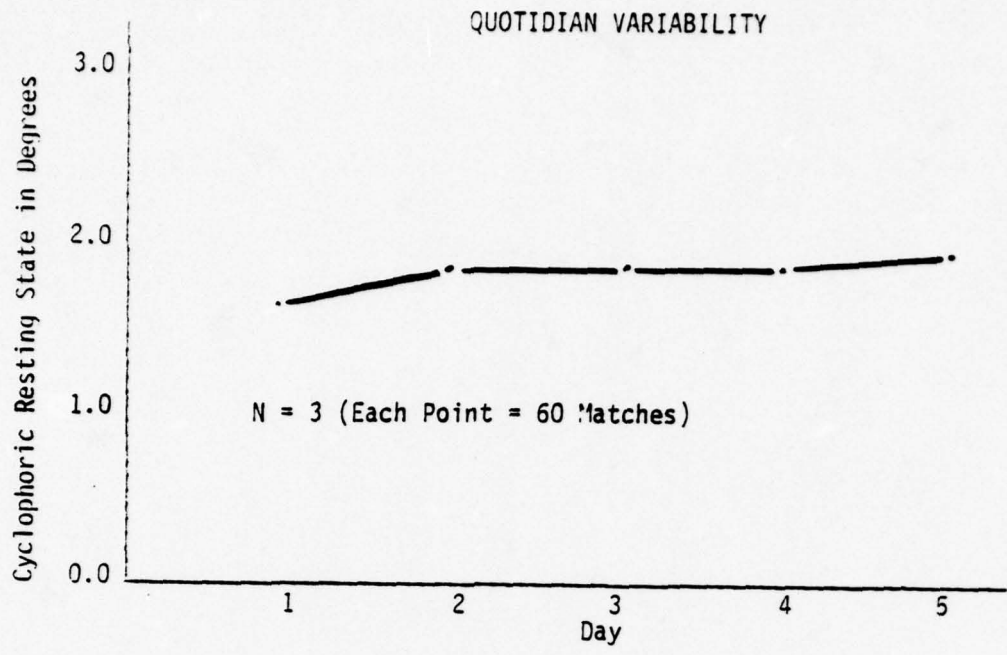

Figure 10: Quotidian and Diurnal Variability of Cyclonhoric Resting State

Table 2: ANOVA of Quotidian and Diurnal Variables and Cyclophoria as Measured by the Circle Bar Test

<u>Source</u>	<u>Error Term</u>	<u>F</u>	<u>Sum of Squares</u>	<u>Deg. Of Freedom</u>
MEAN	S	10.4399	.5546661E 08	1
S (SUBJECTS)		(1412.3685)	.1062587E 08	2
D (DAYS)	SD	0.6877	169638.3	4
T (TIME OF DAY)	ST	0.1275	19791.52	1
SD			493961.8	8
ST			310336.4	2
DT	SDT	0.6782	110028.9	4
SDT			324512.9	8
R (SDT)			2144180.	570

The protocol among the observers indicated that they felt the 20 trials seemed excessively long and their performance fell off on the last few trials. Therefore an investigation of this comment was undertaken. This study showed that the variability on trials one thru five showed a practice effect, and there appeared to be a fatigue effect as a greater variation between trials 15 and 20 was also discovered. A regression representing the prediction of the 20 trial results from a shorter test based on the sixth and sixteenth trial is shown in figure 11. These data imply that one could use five trials as a warm-up then collect the data on the last ten trials, and have a good prediction of the performance based on 20 trials. Based on these data we modified our procedure with the Air Force pilots. We used a 15 trial session, five as practice and basing the estimate of the cyclophoria on the last ten trials.

#### SCREENING OF AIR FORCE PILOTS FOR CYCLOPHORIA

Arrangements were made through Lt. Col. Perdue, of Standards and Evaluation, 62 MAW/DOV, to test the pilots at McChord Air Force Base in Washington. A facility was set aside wherein we could move the equipment from



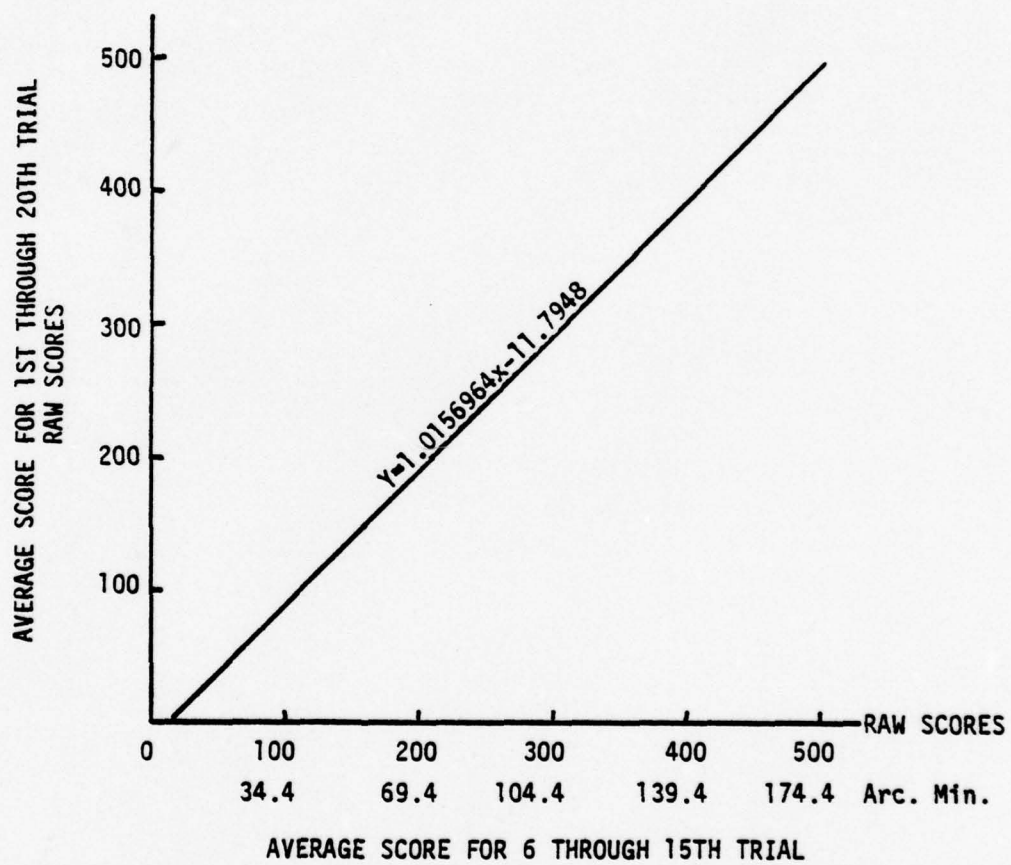

Figure 11 . Prediction of Average Cyclorotation Resting State Based on 20 Trials From the Average of the 10th to 15th Trials

Boeing to McChord and do the testing in a building separate from other Air Force activities. Two pieces of equipment were taken to McChord for the initial testing; an American Optical Sight Screener for testing visual skills and the powered Troposcope for measurement of cyclophoria.

Each pilot was told about the purpose of the study and its general contents and procedure. A bit of biographical information was obtained from them; their name, rank, squadron, age, whether they wore glasses for any occasion. The visual skills test was always given first. The seven visual skill tests administered were duplicated at both far and near viewing distances. The first test was one of fusion. The second, third and fourth were of visual acuity, left eye, right eye and both eyes. The fifth test was on stereopsis, the sixth on vertical phoria, and the seventh on lateral phoria. After a short rest period the pilots were given the instructions on the Circle/Bar cyclophoria test. Before administering this test the interpupillary distance was taken and the instrument interocular eye pieces were set to match this measurement. The convergence of the instrument was always set for zero in the screening test. Five practice trials were given, and, subsequent to that, ten trials which were used for the estimate of the cyclophoria. The digital readout units were summed, regarding sign, indicating the total amount of rotation of the right and the left eye. The sum of these cyclorotations was recorded and the constant representing the constant error of the stimuli subtracted. The corrected sum was converted into arc minutes and also into degrees. The standard deviation reflecting the variation among the trials was calculated and recorded in arc minutes and also as degrees.

Thirty pilots were screened during the course of a one week period. Two out of the thirty were non-flying pilots, the remainder were on active operational status. The results of the screening test were evaluated and 12 representative people from among the 30 were selected for the more extensive testing of the main experiment. The choice of individuals formed a rectangular distribution with stratification among the cyclophoric values that were obtained. If there were more than one choice within an interval, the second criteria was the variance of the Circle/

Bar test. The third criteria was lowered visual acuity in either eye or a lower stereoscopic score. Col. Perdue was provided with a first, second or third choice within the scheduled intervals knowing that he would have some difficulty scheduling all of our first choices.

The representativeness of the stratified sample of the 12 pilots that were the participants in the main experiment is illustrated in figure 12. The individual cyclophorias measured for all 30 pilots screened are also shown in this figure. Note that the inclusive range of cyclophoria is approximately three degrees, with the mean and the median being on the positive side of zero or the physical vertical.

#### PERCEPTION OF THE RUNWAY PLANE

##### Some Perceptual and Physical Aspects of the Stimuli

The computer generated image scenes of three runways viewed from a pilot's eye reference point, on a three degree glide slope, (VFR day and night) were used in studying the perception of the horizontal forward plane. In each scene the glide slope had its origin 1000' from the threshold of the runway. This point was clearly identifiable by the pilots since all the runways had a 1000' symbol in the runway. In the experimental cyclorotation of the images, the center of rotation was this 1000' mark.

The three runways were of different physical dimensions, (MWH = 13,500' x 300'; BFI = 10,000' x 200'; YKM = 6,607' x 150'). The slides, however, reproduced the width of these runways so that all subtended the same visual angle of 5.69 degrees for the group "3" distances. The group "6" distances reproduced these runway widths at 2.286 degrees. This technique reproduced the horizontal plane at a constant three degrees from the line of sight to the 1000 foot mark, but varied altitude by groups and distances by runways.

This selection of parameters controlled the plane of the runway to be always horizontal, the runway width to two levels, the altitude to two levels and the distances to be classifiable as two "groups." However,



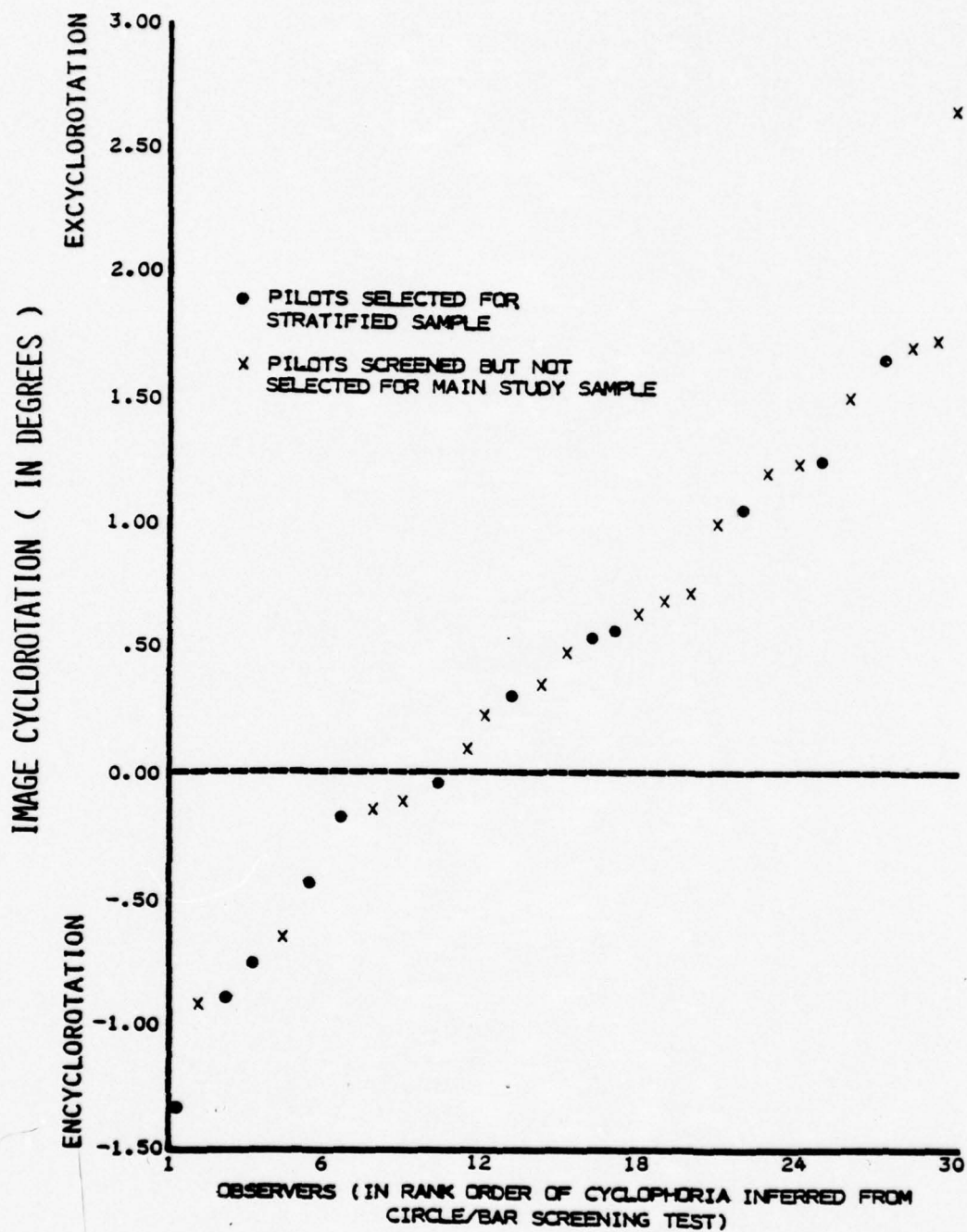

Figure 12. Range Of Cyclophoria In Screening Sample Of 30 Pilots As Inferred From Cyclorotation Of Circle/Bar Test To Achieve Verticality

the distances from the runway touchdown marks were six in number, with the median of the two groups as 3000 and 6000 feet. The actual values were 2499, 3003, 4003, 4750, 5999 and 8499 feet.

In the presentation of these slides to the pilots for judgment of the plane, duplicate slides in each arm of the troposcope presented identical images to the right and left eyes. Such a display, though binocular, was not stereoscopic as no relative displacement of the images existed in the slides. The images were chromatic and of such resolution that the individual holes in the shadow mask of the CRT were visible.

#### Method of Presentation and Procedure

To present the pilots with a series of randomly selected scenes and ask for his judgment as to whether he was "high," "on" or "below" the glide slope requires the pilot to make an "absolute" judgment for each presentation. This frame of reference would have to be his memory of how a three degree glide slope makes the runway plane appear. This procedure has the merit of being similar to the operational task of the pilot. A disadvantage is the relative insensitivity of the "absolute judgment" method. As an example, absolute categories of color discrimination are eleven if spectral hues are judged one at a time. If comparative standards are available, the number of discriminable hues is greater than 2000. The choice of using a comparative technique was chosen for reason of its greater sensitivity.

The method of presenting a "standard" binocular scene with no cyclorotation, compared with a "variable" ( $\pm$  two degrees or zero degrees rotation) scene and requesting a comparative judgment of "apparent altitude" used the sensitivity of the comparative judgement procedure. A second advantage was that such a paired-comparison method coupled with cyclorotation of the visual stimulus represented an indirect test of the influence of cyclophoria. An experimental disadvantage existed in that the influence of the cyclophoric resting state was also imposed on the standard as well as the variable. This dual influence should make any measured difference a conservative estimate of the "true" influence.

In summary, the choice of a paired-comparison method both improved the sensitivity of the measure and imposed a conservativeness on the estimate of cyclophoric effect.

The 12 pilots each made 72 paired-comparisons of the twelve scenes, six of which were day and six were night scenes, two distances were represented and three runways. The major independent variable was the cyclo-rotation of the images at three levels, minus two degrees, zero and plus two degrees.

#### PROCEDURES IN THE EXPERIMENTAL SESSION

The experimental session followed the screening session by one week, and for each pilot this session lasted two hours. The equipment taken to McChord was the powered Troposcope and the Troposcope modified for presenting the ARC and runway test. The procedure was to initially give a repeat of the cyclophoria test with the Circle/Bar stimuli, at zero convergence. Then to give the first half of the runway test or 36 paired stimuli. The Circle/Bar test with five degrees of convergence was the next in sequence and followed by a ten minute rest period. Following the break the ARC test was administered, then Circle/Bar test with ten degrees of convergence. The final portion of this session was the second half of the runway test. This same order was followed for all individuals with random administration by the two experimenters.

The ARC test procedure presented the B, D and F formats three times to each pilot, once each with the zero degree, plus two degree and minus two degree cyclorotation. The format/cyclorotation magnitude combinations were different among the pilots following a prearranged balanced order as a control of possible order effects.

Following the collection of data, the recorded data and the equipment were returned to Seattle. The Circle/Bar data was converted from the instrument units to degrees and submitted for analysis of variance and measures of correlation. Similarly the ARC test and the runway test were converted into a form that could be treated by the large computer.



## RESULTS AND DISCUSSION

### CIRCLE/BAR TEST OF CYCLOPHORIA RESTING STATE

#### Test/Retest Determination of Cyclophoria Resting State

As discussed in an earlier section, the Circle/Bar test was utilized as the primary determinant of the direction and magnitude of cyclophoria in the selection of the stratified sample of 12 pilot/observers. This test was repeated for the 12 selected pilots during the main experimental study and the data are plotted by trials in figure 13. The regression lines for these data are presented in figure 14. As shown in the figures, each session of 10 experimental trials was preceded by five training trials.

The Circle/Bar test appeared to be quite reliable, even with an average observer standard deviation for the 10 trials of .47 degrees. The correlation (Pearson  $r$ ) for the test/retest reliability was  $r = +.93$  with  $p < .01$ ,  $df = 10$ .

#### Main effect of Instrument Convergence

The mean settings for the 12 pilot/observers on the Circle/Bar test with 0, 5 and 10 degrees of convergence set into the A.O. Troposcope are shown in figure 15, and the ANOVA for these results is presented in table 3. The main effect of the different levels of convergence was significant ( $p < .01$ ) and demonstrated a requirement for increased excyclorotation of the Circle/Bar images in order to achieve the "verticality" match, or alignment, of the bar with the reference circle.

Not enough levels of convergence were used to determine whether its relationship with cyclophoria is linear or of a higher order. It might be hypothesized that the increasing incompatibility<sup>1</sup> of the viewing

---

<sup>1</sup>The Circle/Bar test was presented at optical infinity for both the five and ten degree convergence conditions as well as for the compatible zero degree convergence setting.



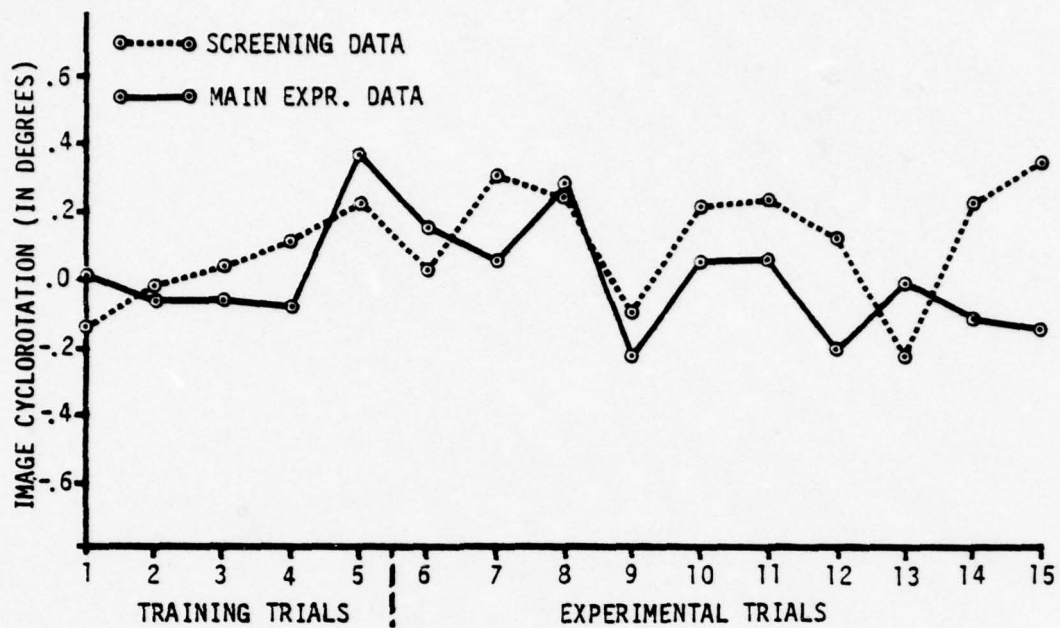

Figure 13: Cyclophoria Data by Trial 12 Observers During Both Screening and Experimental Sessions.

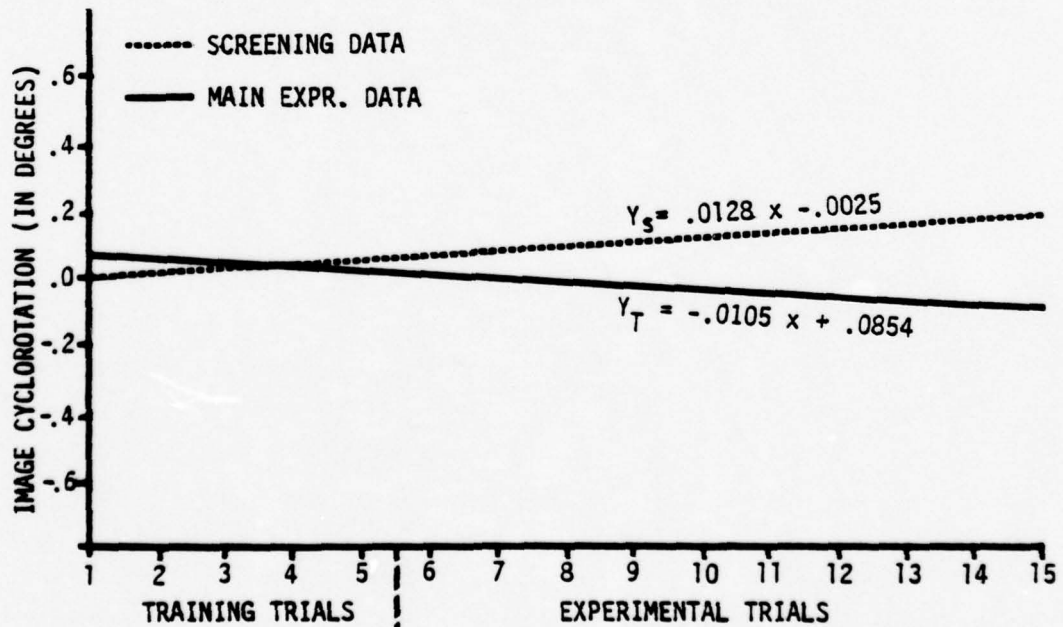

Figure 14: Regression Lines for the Cyclophoria Data on 12 Observers During Screening and Experimental Sessions

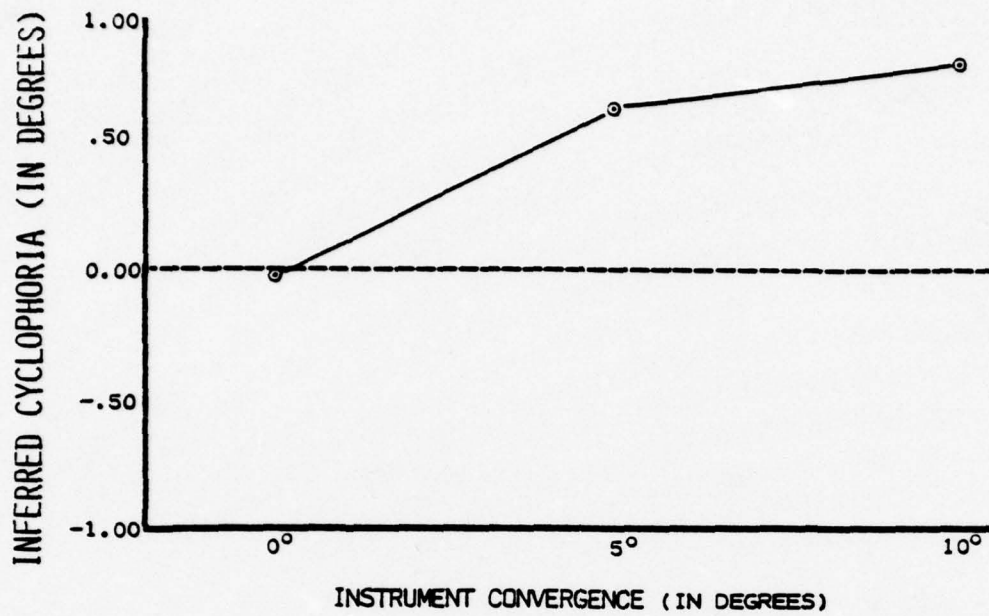

Figure 15 : The Effect of 0°, 5° and 10° of Convergence in Troposcope (Stereoscope) on Cyclorotation Settings to Verticality in Circle/Bar Test (for Selected Sample of 12 Pilots)

Table 3 : ANOVA for the Effect of 0°, 5° and 10° Convergence on Cyclophoria Measurements for 12 Selected Pilots

<u>Source</u>	<u>Error Term</u>	<u>F</u>	<u>Sum of Squares</u>	<u>df</u>
MEAN	S	3.0797	86.06570	1
SUBJECTS		(95.6569*)	307.4028	11
CONVERGENCE	SC	7.3421*	47.26588	2
SC			70.81444	22
T(SC)			94.65503	324

conditions acted to attenuate the effect of the increased instrument convergence from what might otherwise have been a linear relationship.

In comparing these data with those reported by other investigators, general agreement is found in both the direction and magnitude of the effects of convergence on the cyclophoria resting state. Figure 16 presents the relationships found by several others as compared with the data from this study. Since the mean with  $0^{\circ}$  convergence for the 12 selected observers is almost  $.5^{\circ}$  below that for the 30 pilots represented in the screening data, a plot of the effect of  $5^{\circ}$  and  $10^{\circ}$  of convergence on the cyclophoria resting state of this larger, more random sample, would likely fall between the data of Landolt/Carow and those of Hermans/Allen. Figure 17 plots the means for each pilot.

The correlations between the means for cyclophoria under the different conditions are shown in table 4. There appears to be a general deterioration in the relationship as a function of the difference in convergence between the two correlated variables.

Table 4. Correlations Between the Measures of Cyclophoria for the Screening Condition ( $0^{\circ}$ ) and the  $0^{\circ}$ ,  $5^{\circ}$ , and  $10^{\circ}$  Convergence Experimental Conditions (for 12 Selected Pilots)

	SCREENING $0^{\circ}$	M A I N $0^{\circ}$	E X P E R I M E N T	
			$5^{\circ}$	$10^{\circ}$
$0^{\circ}$	1.00	.93	.76	.62
$0^{\circ}$		1.00	.73	.53
$5^{\circ}$			1.00	.88
$10^{\circ}$				1.00

#### Mean Cyclophoria and Among Pilot Average Variances

Imposing cyclotorsional effects by changing convergence from zero to five and to ten degrees imposes a progressively more positive cyclophoria. The average variance among the twelve pilots is similar for the zero and five degree convergence and decreases for ten degrees of convergence. However, these differences in average variance are most

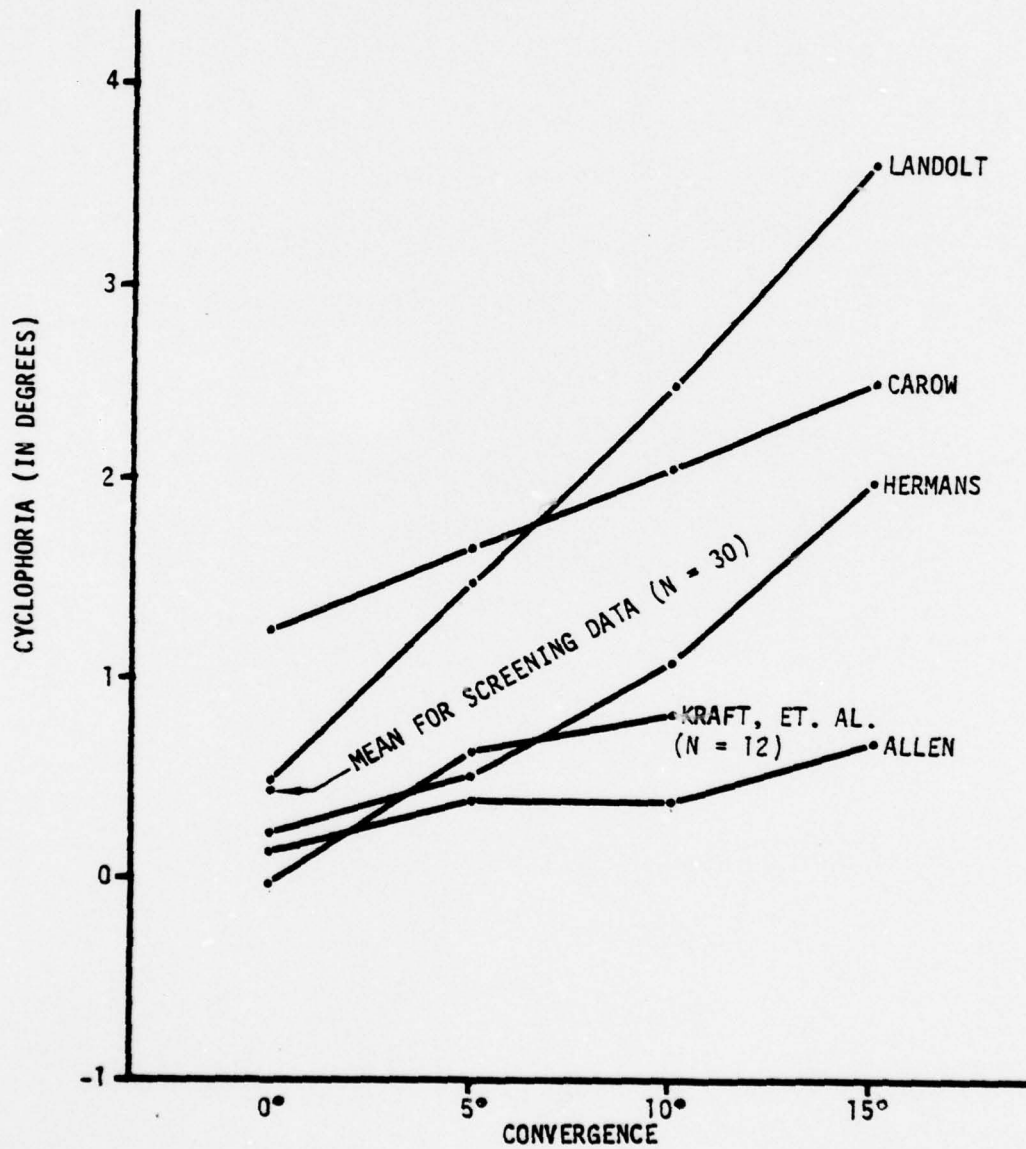

Figure 16: Comparisons Among Several Investigator's Data on the Effect of Convergence on Cyclophoria (All except Kraft, et al. data taken from Allen, 1954).



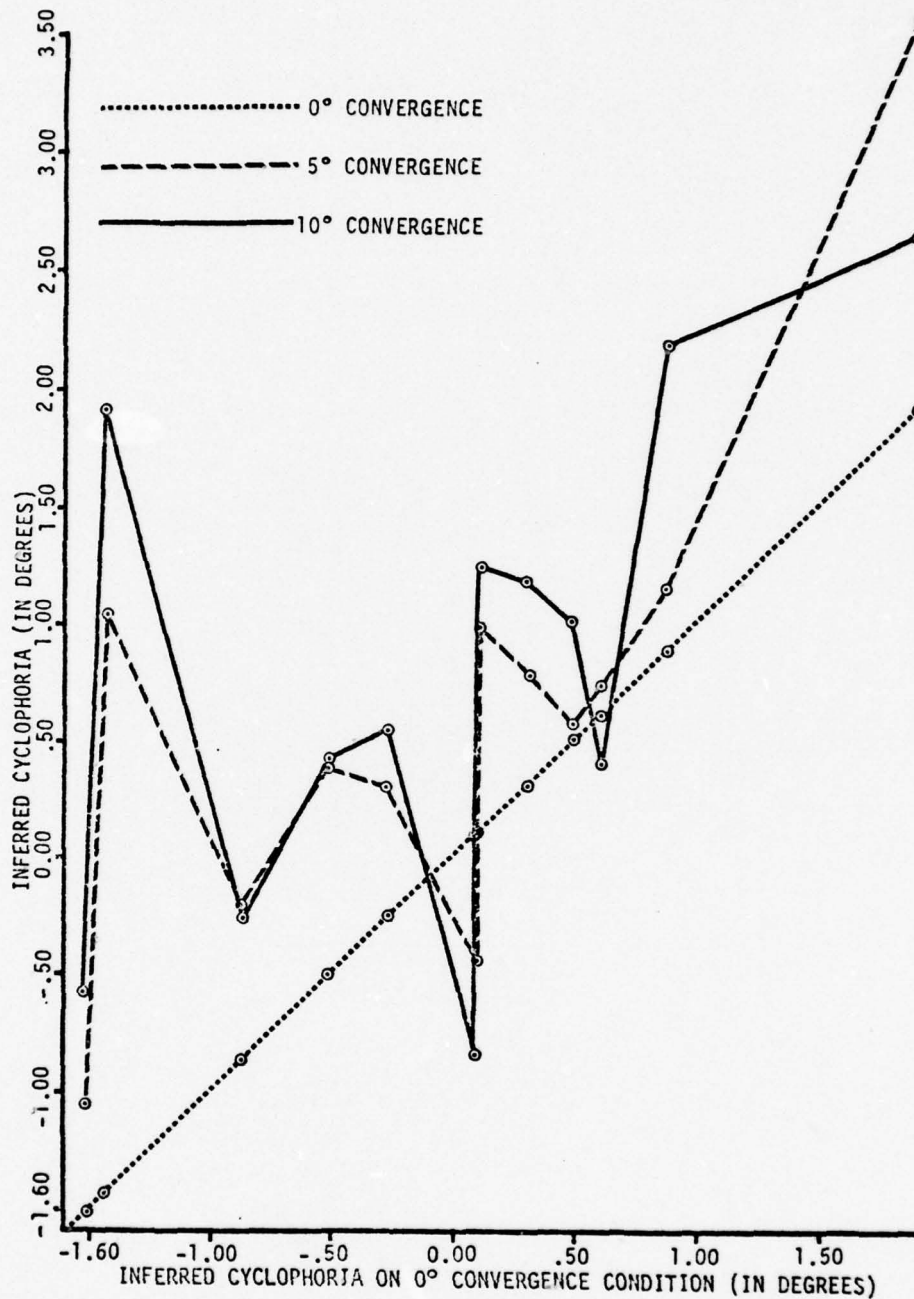

Figure 17. Effects of 5° and 10° of Convergence on Circle/Bar Settings for Each of 12 Observers (Plotted Against 0° Convergence Settings)

likely due to chance. The chance contribution is supported by 't' tests and the observations that the major contribution to this variance is by one individual, although not the same individual for the zero and five degree convergence imposed cyclotorsion.

#### Magnitude of Cyclophoria and Intertrial Variance

The correlation between the magnitude of the cyclophoria and the variance among the 10 trials, whose average is the measure of cyclophoria, is high and positive for the zero convergence ( $r = .87$ ). The same relationship is intermediate ( $r = .55$ ) and positive for five degrees of convergence, and low ( $r = .27$ ) and positive for the 10 degrees of convergence. These correlations were made disregarding the direction of the cyclophorias as a U-shaped distribution exists between cyclophoria and the variance among trials (see figure 18). Those individuals whose resting state in cyclorotation is near the physical vertical usually have the small variances among the individual measurements of cyclophoria. Those pilots whose resting states are .80 degrees or greater from the physical vertical have the larger differences among the ten trials.

The explanation of the relationship measured between magnitude of cyclophoria and the intertrial variance is an unknown. It may be conjectured that the individual whose resting state of cyclorotation differs by approximately one degree or more from the physical vertical, is in every day visual experience making cyclotorsional corrections for this disparity. With this acquired "flexibility" of cyclorotational experience he may, in making the individual matches in the Circle/Bar test, accept a wider range of apparent equalities than his peers who have a resting state near zero.

The hypothesis of "acquired flexibility" would also apply to these data of decreased variability as convergence is increased. The cyclotorsional stress may modify a normal distribution of responses on either side of the mean (resting state of cyclophoria) toward fewer responses on one side of the resting state, as in a Poisson distribution. Considering

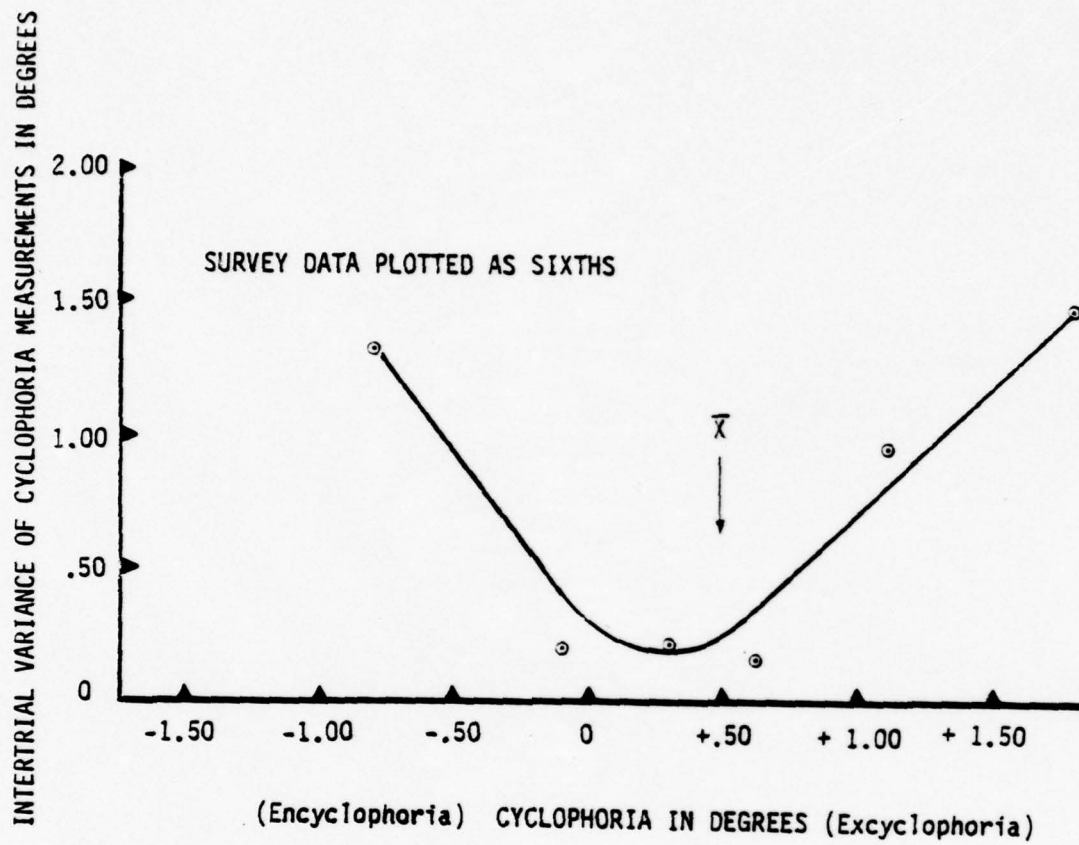

Figure 18: Relationship Between Magnitude of Cyclophoria and Intertrial Variance

that cyclophoria is a myologic or muscular state, the increased tonus in one direction decreases the probability of responses in the direction opposite to that tonus. The effect is to decrease the total spread of responses among the ten trials and thereby decrease the size of the variance with increased convergence.

A second hypothesis is that the method of measurement imposes this change in variance. The visual accommodation in the Troposcope should be nearly zero as the image is positioned at optical infinity. The zero convergence condition is compatible with this accommodation distance as the eyes should be nearly parallel for infinity viewing. Whenever convergence and accommodation are not compatible, a neuromuscular stress situation is imposed. The convergence of 5 and 10 degrees, with continued accommodation at infinity, is just such a non-compatible condition. Therefore, as the innervation from the imposed convergence increases, the freedom of interaction between accommodation and convergence is constrained, and possibly the measured variance of cyclophoria is also constrained.

The latter hypothesis is easily testable and therefore may be established or disproved. The method of testing would be to measure cyclophoria as a function of convergence with compatible accommodation and determine if the magnitude and the distribution of the variance is independent of convergence. As an example, repeat the current study with spectacle lenses of 1.4 diopters before the eye with  $5^{\circ}$  of convergence, and 2.75 diopter lens combined with the  $10^{\circ}$  of convergence. If the variance remains of similar magnitude and type of distribution for each of the convergence/accommodation combinations, then the decreasing cyclophoria variance is a product of the "stressful" and non-compatible situation and is an artifact of the method of measurement employed in this investigation.



## THE ARC TEST MEASURE OF CYCLOPHORIA

### Effect of Image Cyclorotation on ARC Test Responses

The ARC Test was given to each of the 12 observers under three conditions of image cyclorotation:  $2^{\circ}$  excyclorotation,  $0^{\circ}$ , and  $2^{\circ}$  encyclorotation. The  $\pm 2^{\circ}$  of image cyclorotation produced shifts in the ARC test responses that were, for the most part, equal in magnitude and opposite in direction from the mean response to the  $0^{\circ}$ , or non-cyclorotated, condition.

Figure 19 represents the mean responses of each of the 12 observers for the three image cyclorotation conditions. The  $\pm 2^{\circ}$  cyclorotation conditions are plotted against the  $0^{\circ}$  condition, which is plotted against itself as a baseline condition. While there was considerable individual variance, the main effects were quite uniform and significantly different. Figure 20 presents the means for the three image cyclorotation conditions, along with plots of the means as corrected by the  $0^{\circ}$  shift and a calculated line predicted from the total amount of disparity induced by the image cyclorotation. Table 5 provides the corresponding ANOVA. Although both "Formats" and "Rows within Formats" had statistically significant effects, they were both confounded in the test procedure by order effects and R(F) was additionally confounded with test structure characteristics. In prior administrations of the ARC test, random presentations of the ARC test formats produced non-significant effects. The response means are presented in table 6 below.

Table 6. The Mean Shifts in ARC Test Responses for  $\pm 2^{\circ}$  Image Cyclorotation Compared With the Responses on the Non-Cyclorotated ( $0^{\circ}$ ) Condition

IMAGE CYCLOROTATION CONDITION	MEAN RESPONSE SHIFT FROM TRUE NULL (IN ARC SECONDS)	MEAN SHIFT FROM NON-CYCLOROTATED CONDITION (IN ARC SECONDS)
$2^{\circ}$ EXCYCLOROTATION	-25.1	-13.5
$0^{\circ}$	-11.5	-
$2^{\circ}$ ENCYCLOROTATION	+ 2.1	+13.6

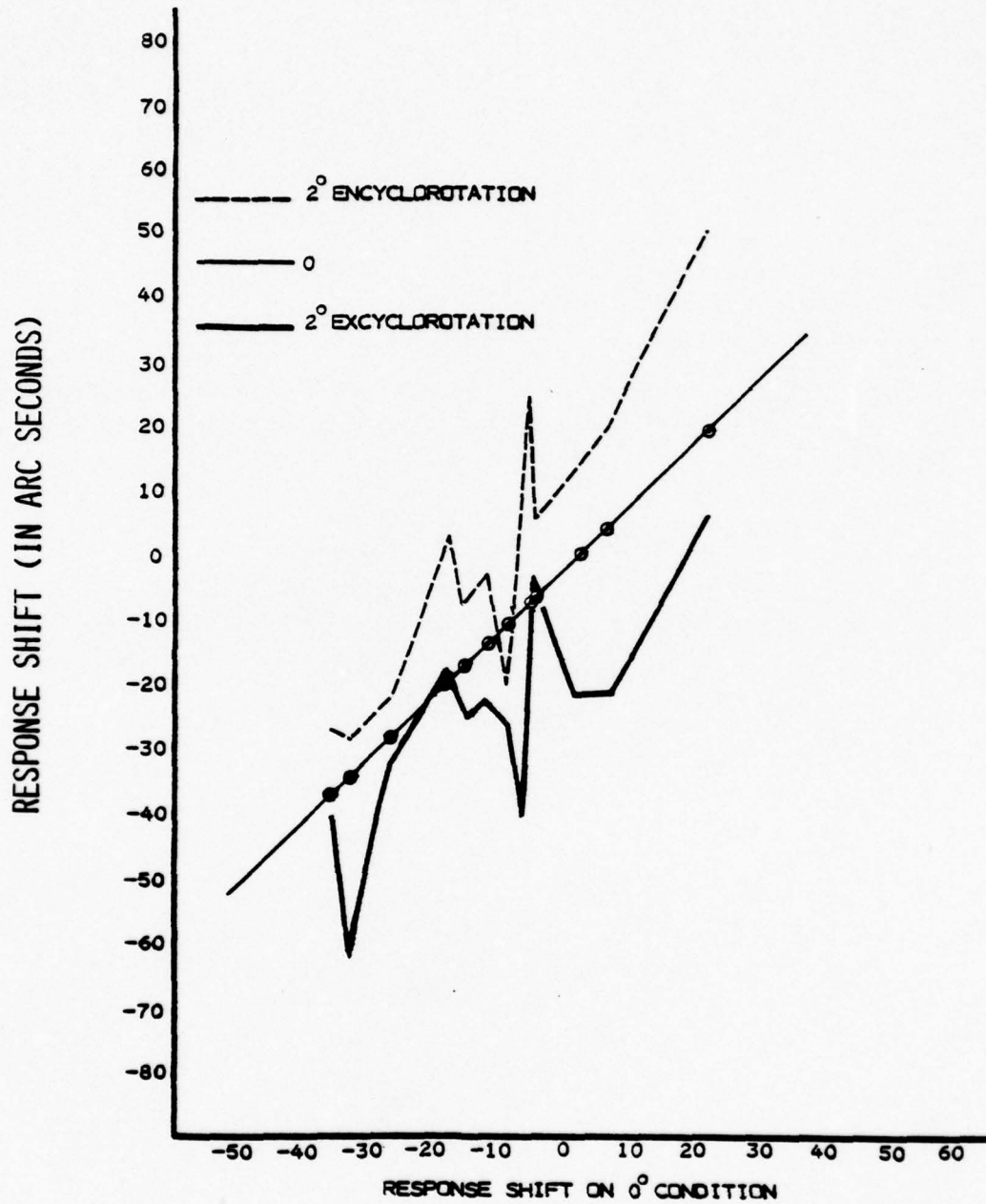

Figure 19 : Effects of  $\pm 2^\circ$  of Image Cyclorotation on Responses on ARC Test for Each of 12 Pilots (Plotted Against  $0^\circ$  Cyclorotation Responses as Baseline)

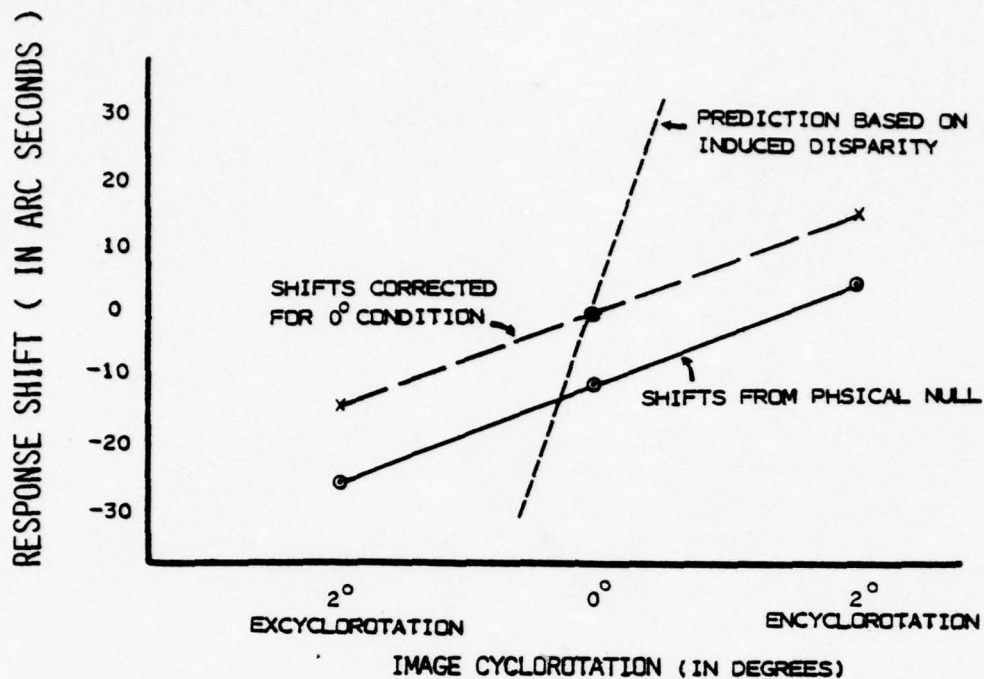

Figure 20. Effects Of Image Cyclorotation On Perceived Crossover Point (Verticality) In Arc Test Compared With The Induced Disparity (12 Observers)

Table 5 : ANOVA for Effects of Image Cyclorotation on Cyclophoria as Measured With the ARC Test

Source	Error Term	F	Sum of Squares	df
MEAN	S	4.89	129237.9	1
SUBJECTS		(82.36*)	290936.1	11
CYCLOROTATION	SC	22.52*	119723.7	2
FORMATS	SF	10.50*	20939.84	2
ROWS(F)	SR(F)	8.92*	155917.9	24
SC			58480.38	22
SF			21925.59	22
CF	SCF	0.77	1709.156	4
SR(F)			192211.6	264
CR(F)	SCR(F)	1.62	24964.47	48
SCF			24498.13	44
SCR(F)			169563.1	528



These response shifts were consistent in direction with the effect produced in the Circle/Bar test, i.e., image excyclorotation causes the top of the bar to be perceived as tipped or inclined away from, and the bottom toward, the observer. In the case of the ARC test, the responses under conditions of image excyclorotation indicate that the top of the two rows of discs being compared is seen as moved away from, and the bottom row moved toward the observer, thus shifting the perceived crossover point.

The magnitude of this shift, however, is much less than would be expected if the disparity induced in the ARC test through image cyclorotation were fully reflected in the observed response shifts. The prediction, as plotted in figure 20, is based upon the induced disparity, which can be calculated with the following equation:

$$\eta = \frac{206265 (M) (2r) (\sin \theta/2)}{10}$$

where  $\eta$  is in arc seconds; M is image magnification in the Troposcope compared with a standard 10 inch viewing distance; r is the vertical row-to-row spacing; and  $\theta$  is the angle of image cyclorotation for both eyes (in degrees). For the conditions of this study:

$$M = 1.23$$

$$r = .1286 \text{ inches}$$

$$\theta = 2.0 \text{ degrees, and}$$

$$\eta = \frac{206265 (1.23) (.2572) (.0175)}{10}$$

$$\eta = 114.2 \text{ arc seconds per } 2^{\circ} \text{ cyclorotation}$$

As can be seen, the observed shift is only about 1/8 the magnitude of the induced disparity. This "incomplete" effect was not unexpected, in that almost all investigators have found the perceived effect to be attenuated by various amounts, usually as a function of stimulus complexity. This attenuation of the perceived effect has been attributed by some to a cyclofusional response of the eyes (Ogle & Ellerbrock, 1946; Crone and Everhard-Halm, 1975; Harker, 1962) or contrastingly to a mediating central response with only a minor motor component (Kertesz,

1972). Since an objective measure of eye cyclorotation was not attempted in the current study, no inference can be made as to the physiological correlates of the observed effects. The most convenient hypothesis for this relationship, however, would be to propose involvement of the stimulus complexity of the ARC test, primarily in that the horizontal arrangement of the rows of discs produce, under cyclorotation, vertical disparities which are strong stimuli for cyclotorsional or cyclofusional movements of the eyes. It would follow that to the extent that such cyclofusional movements might occur, the disparity between the vertical meridians of the ARC test images and those of the retinas would be reduced--to the residual amount reflected in the observed response shifts.

While there was, in this study, no direct measure of cyclofusional movements, there is additional circumstantial evidence that such movements, or imitative central processes, do take place. The most striking difference in the appearance of the Circle/Bar test and that of the ARC test under cyclorotational excursions is that while the vertical bar in the Circle/Bar test readily tilts back and forth in response to cyclic image cyclorotations, there is no corresponding perceived tilt in the fronto-parallel plane of the ARC test with similar excursions. Rather, the ARC test appears to maintain its verticality, even while individual pairs of adjacent rows of discs undergo differential changes in relative depth. In a test session by these investigators, and using each other as observers, image cyclorotations of  $\pm 5^\circ$  produced perceived shifts in the crossover point equivalent to about 96 arc seconds. Over the vertical extent of the ARC test, this would amount to a depth disparity between the top and bottom rows of 864 arc seconds. For this amount of disparity, the ARC test should appear tilted out of the fronto-parallel plane by an angle calculated by:

$$\tan \theta = \frac{NR^2}{rA(206265)}$$

where  $\theta$  equals to angle of inclination; N equals the disparity in arc seconds of the observed shift; R equals the viewing distance corrected for image magnification; r is the disc-to-disc spacing; A is the observer's interpupillary distance, and 206265 is a constant of conversion from arc seconds to radians.

In this instance:

N = 96.0 arc seconds  
R = 8.14 inches  
r = .128 inches  
A = 2.48 inches (average of 63 mm for population)

and:

$$\tan \theta = \frac{96.0 (8.14)^2}{.128 (2.48)(206265)} = .0971$$

$$\therefore \theta = 5.55 \text{ degrees}$$

This apparently dichotomous perceptual phenomenon could perhaps be resolved by postulating a dual system of visual space analysis. Gogel (reviewed by Harker, 1962) suggested such a dual system in which one factor, the "equidistance tendency", acted to maintain all objects in the field in the same fronto-parallel plane. The second mechanism acted to analyze the binocular disparities between individual, adjacent objects within the scene. A similar dual mechanism was also proposed in a binocular/cyclotorsional context by both Werner and Ogle (reviewed in Harker, 1962), and termed the "binocular depth contrast phenomenon" by Werner.

The practical importance of this phenomenon, in the context of the present study, is that cyclorotational or cyclotorsional disparities in scene elements may be masked by a normal-appearing overall scene, yet produce errors in judgment of relative depths or distances of individual scene objects or extents.

#### Response Shifts on the ARC Test With No Cyclorotation

Another anomaly in the responses on the ARC test involves the significant shift from the true crossover point under the 0° image cyclorotation condition. The mean inferred cyclophoria for the 12 observers in the stratified sample was - .014 degrees (in the encyclophic direction) as measured with the Circle/Bar test with 0° of convergence. It would be predicted from this small net cyclophoria that responses on the ARC test for the non-cyclorotated condition would center around the physical or true crossover point. This was clearly not the case, with a mean shift of -11.5 arc seconds from the true crossover point ( $Z = 2.424$ ,  $p < .05$ ). Evidence that this shift may represent a reliable and noteworthy phenomena has been found in the results of earlier work.



It had been hypothesized following an earlier study of chromostereopsis (Anderson and Kraft, 1977) in which the ARC test was developed and utilized, that a small amount of inadvertent image cyclorotation, combined with the observer's cyclophorias, had been responsible for curious, constant errors in responses on the ARC test. All but one of the 12 observers in the earlier investigation evidenced a negative shift (image excyclorotation and/or observer encyclophoria) on the ARC test, with the average shift of 14.8 arc seconds ( $Z = 3.92$ ,  $p < .01$ ). Although an independent measure of cyclophoria was not taken, the variability in the ARC test shifts indicates that a fairly wide range of individual cyclophorias may have been represented in this sample of observers. The correlation ( $r = +.97$ ) between these two observer samples, paired by the magnitude of the ARC test shift, is indicative of the similarities in the direction, range, and variance of the ARC test shifts observed.

At present, there appears to be no obvious explanation of this observed shift for the non-cyclorotated test condition. It is tempting to hypothesize, however, that this shift might be a reliable indicator of the difference in cyclotorsional response coupled with central perceptual processing of the relatively free-floating Circle/Bar test versus the more complex and structured form of the ARC test.

In addition to the shift in the overall mean, the individual observers' shifts on the ARC test do not follow the prediction based upon their direction and magnitude of cyclophoria as measured with the Circle/Bar test. Figure 21 plots each observer's ARC test response shift (zero degrees cyclorotation condition) as a function of the inferred cyclophoria, along with the regression line and the predicted shift line. The correlation between the two measures was  $-.34$  (non-significant). That this apparent "reverse shift" is a form of overcompensation for the individual's cyclophoria resting state is, without further data, a very speculative hypothesis at this time.



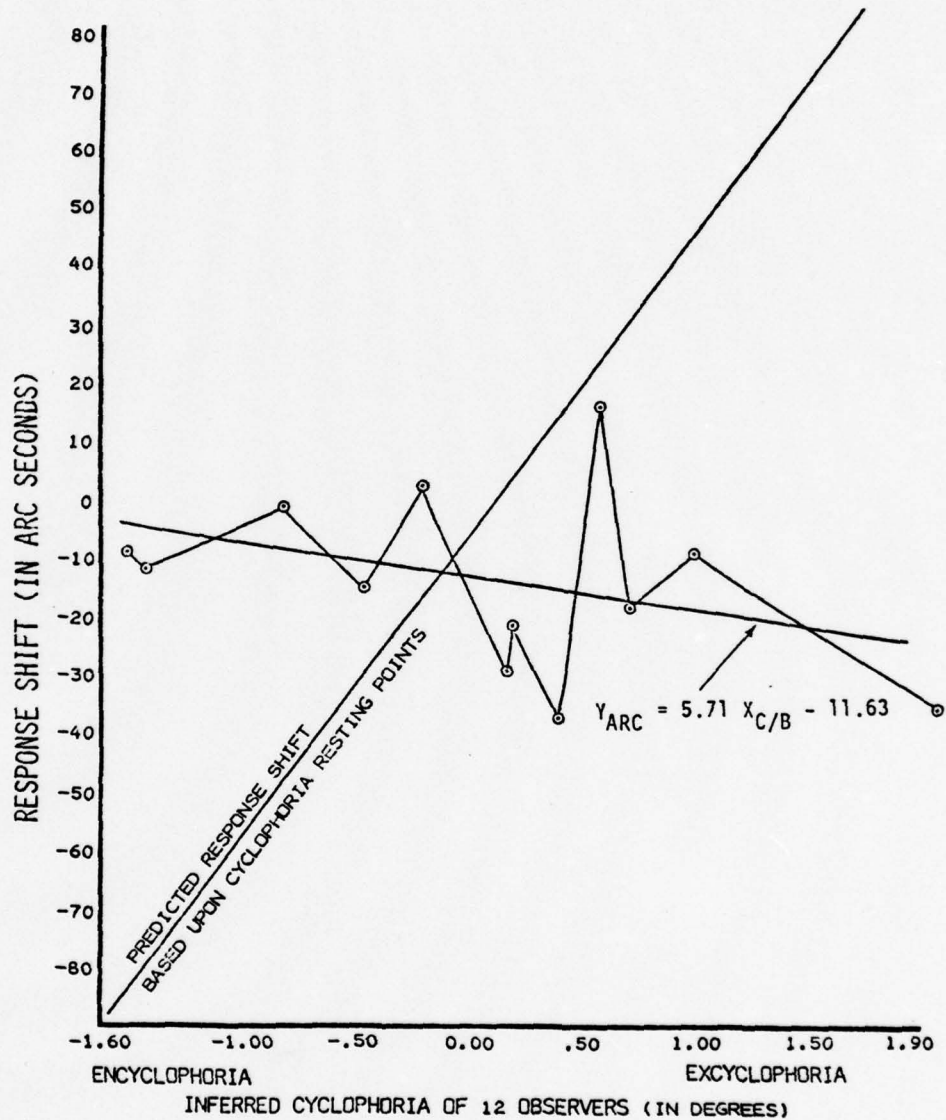

Figure 21 : Observed Versus Predicted Response Shifts on ARC Test (0° Convergence) for 12 Pilots Based Upon Cyclophoria Resting Point Inferred From Circle/Bar Test

## PERCEPTION OF THE RUNWAY PLANE

### Effect of Image Cyclorotation on Responses to Runway Test

The results of the test on the pilot's perception of the runway plane under zero and plus or minus two degrees image cyclorotation were analyzed by ANOVAs, correlation analysis and stepwise regressions. The first ANOVA used a "Briggs" arcsin transformation which assigned values of 17, 45, and 73 for zero, 50% and 100% "higher" responses for each pair of two comparisons. This analysis indicated that the cyclorotation variable was significant ( $F = 6.07$ ;  $P < .01$ ) but the effects of all other variables could be due to chance. This ANOVA is shown in table 7.

The second overall ANOVA covered the same independent variables and the value of the dependent measure was the proportion out of two which were "higher" responses. This analysis also indicated that the cyclorotation was a significant variable ( $F = 6.07$ ;  $p < .01$ ). The transformed and non-transformed data provided the same information, i.e., only cyclorotation provided differences of a magnitude that the null hypothesis could be rejected.

Figure 22 illustrates the distribution of "higher" responses among the two degree cyclorotated images, the zero and the two degree cyclorotated images. The results were in the direction of the hypothesis that cyclorotation would be related to how pilots perceived the horizontalness of the runway plane. The excyclorotation would tip the apparent plane to make the perceived aircraft height less than the standard zero degrees of rotation. The percent of "higher" responses was 41 percent for the two degrees of excyclorotation of the pictorial scenes. The encyclorotation of two degrees increased the "higher" responses to 61.1 percent, from which one may infer that the pilots perceived the runway plane to be tipped such that the perceived aircraft altitude was above the three degree glide slope.

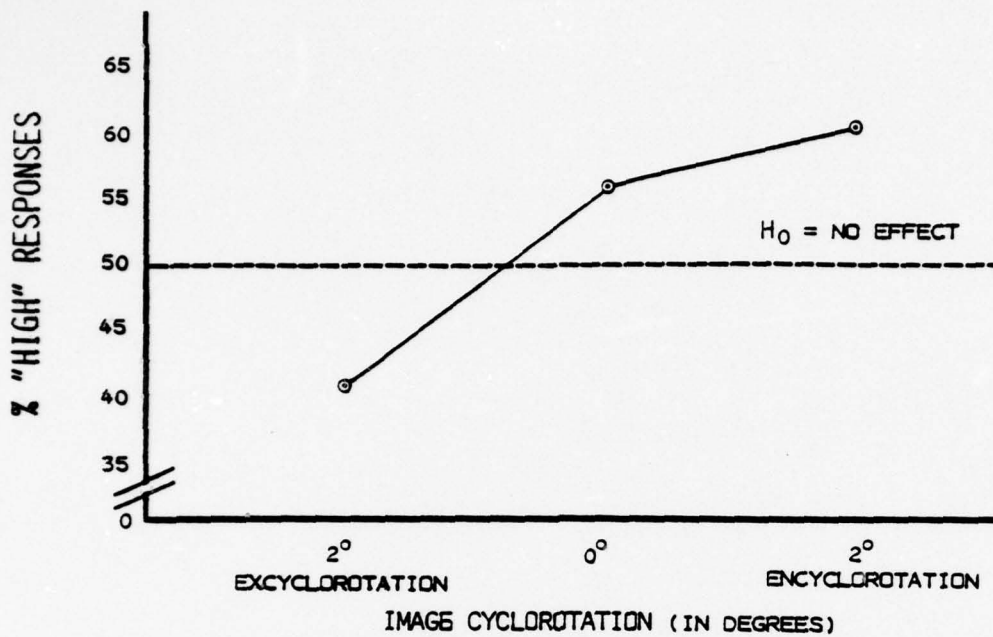

Figure 22 : Effect of Image Cyclorotation on the Percentage of "High" Responses on the Runway Glideslope Perception Test

Table 7 : ANOVA for Effect of Image Cyclorotation on Percentage of "High" Responses on Runway Test

Source	Error Term	F	Sum of Squares	df
MEAN	S	*****	933719.7	1
SUBJECTS			9384.402	11
RUNWAYS	SR	0.8579	286.7405	2
TIME OF DAY	ST	0.0434	16.33333	1
DISTANCE	SD	0.0535	16.33333	1
CYCLOROTATION	SC	6.0729*	9868.957	2
SR			3676.783	22
ST			4143.191	11
RT	SRT	2.5897	1186.887	2
SD			3359.202	11
RD	SRD	0.0232	10.88908	2
TD	STD	2.4481	408.3330	1
SC			17875.87	22
RC	SRC	0.2867	529.9258	4
TC	STC	1.1854	1012.668	2
DC	SDC	0.6820	424.6641	2
.				
.				
.				
SR TDC			23840.64	44



The comparison of a "standard" of zero cyclorotation and a subsequent presentation of the same scene again with zero rotation should have an expectancy of 50 percent "higher" responses. The 55 percent of observed "higher" responses represents a bias of calling the second of an identical pair as "higher." The five percent above the expected frequency, however, is well within that which could be expected from chance.

The effect of the length of the runway on the frequency of the judgment of "higher" was a trend that proved to be of no statistical significance (see table 8).

Table 8: Runway Length and Frequency of "Higher" Responses as a Function of Cyclorotation

<u>Runway Length</u>	<u>Proportion of "Higher" Judgments</u>
13,500	50.7 %
10,000	53.1
6,700	54.2

These data apply when the glide slope is three degrees from the visual touchdown mark, and the slant range to the runway threshold makes the runway width have a common visual angle on the retina of the pilot's eye. The runway's outline pattern under the conditions is provided in figure 8.

These data, relating length of the runway to frequency of "higher" judgments have an interesting relationship with data that pertained to further shortening of the runway by reducing the runway visual range (R.V.R). Figure 23 illustrates this relationship. The right side of this figure comes from the AFOSR data and each point is the proportion of "higher" judgments in 24 discriminations for each runway length for 12 pilots. The left side is from the BCAC study that also used 12 MATS pilots but the number of discriminations is 1/2 as many, or 12 per pilot, per data point.

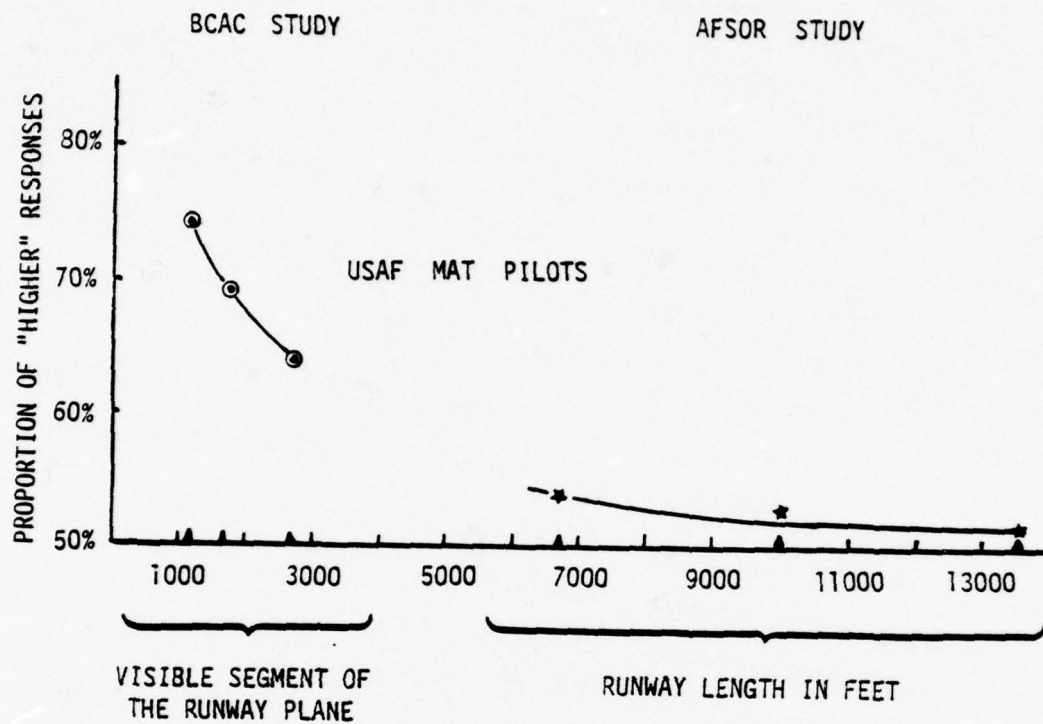

Figure 23. Influence of Cyclorotation on the Proportion of "Higher" Estimates of Aircraft's Altitude as Length of Visual Features Decreases.

The hypothesis that a pilot's resting state of cyclophoria would influence his perception of the frontal horizontal plane is supported by both sets of data. With encyclorotation of the images, the frequency of "higher" judgments is increased and excyclorotation decreases the frequency of "higher" judgments. In the BCAC data, the above proportions are based on difference scores, transformed as arc sines, and treated in an ANOVA. The variable of rotation although systematic is not statistically significant due to the large individual differences among the 12 pilots. Treating each visual segment separately, with a  $X^2$  test, determined that only the 1146' visual segment produced significantly different frequency of judgments of "higher."

The data referred to as the BCAC study was a subsequent data collection to this contract's data collection.

The Boeing Commercial Airplane Company (BCAC), asked of the authors if increasing "over-the-nose" visibility could be related to approach and landing safety. With the approval of the Life Sciences Division of AFOSR, and a very cooperative assistance of MATS at McChord AFB, a quick response was made to BCAC. Other details of this preliminary study are provided in appendix 2.

The inference made from the combined data is that the effects of cyclo-rotation have greater influence on the estimates of the aircraft's altitude, as judged from the perception of the runway plane, as the length of the visual segment is decreased.

If these preliminary data are supported by subsequent research, the implication is (1) that as weather decreases the length of the visual segment available to the pilot the greater the probability of his overestimating his altitude above the plane of the earth; (2) that this probability will be higher if his personal cyclophoria is excyclophoric; (3) that the probability is lower if his resting state is encyclophoric.

Neither of the main effects of time-of-day nor distance (aircraft to runway touchdown mark) proved to be significant (see table 9). The



authors had hypothesized that the night scene, with the details provided primarily by point-sources of lights, would provide less information to the pilot as to the aircraft's height. Then too, this scene with less information would be more susceptible to the influences of cyclorotation. This hypothesis may be correct but the current data does not provide differences of such magnitude that the hypothesis is supported. The trend is in the direction of this hypothesis as cyclorotating the day scene images imposes a greater proportion of "higher" responses with encyclorotation and a decreased proportion of "higher" responses with excyclorotation. This is shown in figure 24 by the greater number of correct responses associated with the day scene when contrasted with the night scene.

The two median distances, 3000 and 6000 feet (figure 24) for the two nominal sets of photographs show very little susceptibility to the effects of cyclorotation. The greater distances, or the smaller sized image of the runway is more susceptible to the effects of cyclorotation. Rearranging the variable of distance, into the six discrete magnitudes, indicates no systematic effect. The magnitude of the small effects are, when ordered from least to largest magnitude, related to runway configurations, MWH, BFI and YKM. Therefore if there is any trend it may be specific to runway configuration when the runway widths are matched, and reproduced as widths of 5.7 and 2.28 degrees of visual angle.

#### Effect of the Pilot's Cyclophoria on Responses to the Runway Test

The individual differences among pilots as to the direction and magnitude of cyclophoria has been discussed earlier. The correlation of this resting state with the perception of the depicted aircraft height was in the direction of the theoretical development (see figure 25).

Those pilots with "positive" resting states (excyclophoric) were expected to perceive the runway plane as being tipped so that distant features would be perceived as higher than they were depicted in the photographic scene. The pilots with "negative" or encyclophoric resting states would see distant objects as lower than the photographic depiction. Table 10 is

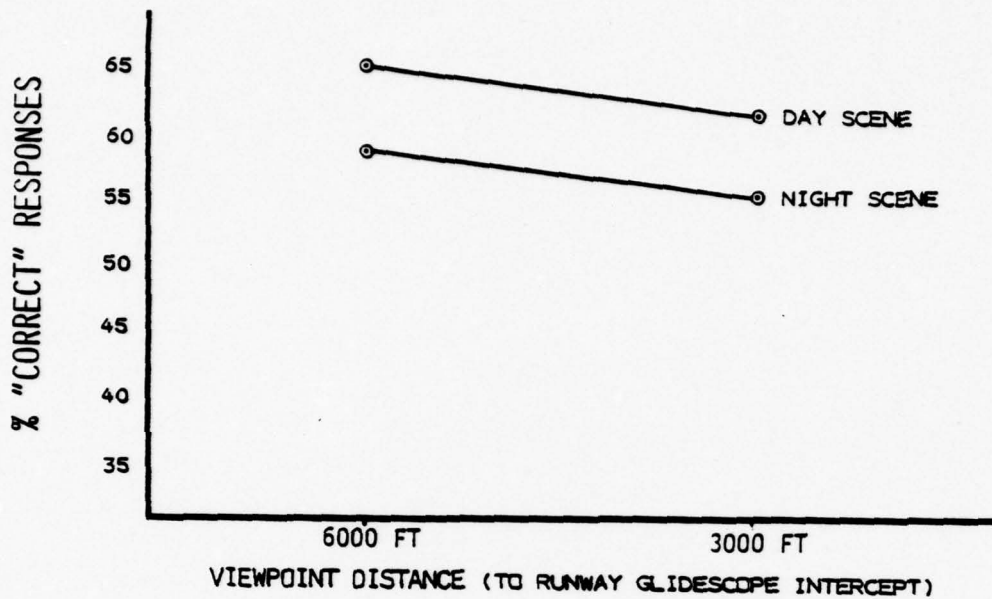

Figure 24: The Main Effects of Time-of-Day and Distance on the Percent "Correct" Responses on the Runway Glide-Slope Perception Test (neither main effect was significant).

Table 9: ANOVA for Results on Runway Perception Test Scored on Basis of Number "Correct"

Source	Error Term	F	Sum of Squares	df
MEAN	S	237.6890	520562.2	1
SUBJECTS			20922.22	11
RUNWAYS	SR	0.6723	796.6248	2
TIME-OF-DAY	ST	1.9949	1418.778	1
DISTANCE	SD	1.1043	625.0000	1
SR			13033.72	22
ST			7823.320	11
RT	SRT	0.2017	231.2639	2
SD			6225.813	11
RD	SRD	1.6578	2545.867	2
TD	STD	0.0001	.2783203E-01	1
SRT			12615.32	22
SRD			16893.07	22
STD			5075.105	11
RTD	SRTD	0.2902	545.8367	2
SRTD			20692.55	22

a portion of the table of intercorrelations, shows this direction. This theoretical direction would predict the negative correlations between the C/B test and the percent of higher responses on the runway perception test, ex-rotation (variables 1-15 with 10). The theory would also predict the positive correlations between the C/B test and the percent of "correct" responses. Correctness in this instance was "higher" response for encyclorotation and "lower" response for excyclorotation.

The prediction of the runway perception test with zero rotation (variable 9) from the C/B test should be near zero and these data are supportive of this relationship. There is a residual factor, however, that is predicted to nearly a probability of 0.10 by the ARC test when the latter is also administered with zero cyclorotation (variable 6 vs. 9). Excyclo-rotation of the ARC test best predicts the encyclorotation effects on the runway test (variables 7 vs. 8) of all the variables shown in table 10.

The above discussions of correlational relationships should be considered as trends as  $r$  values of .497 and .576 are representative of  $p = 0.10$  and  $p = 0.05$ .

A step-wise multiple correlational analysis was run with 18 variables including those discussed above. Those that best predicted variable 11, the percent correct responses on the runway perception test, were those shown in the lower section of table 10. They were Circle/Bar, 10 degree convergence; C/B, zero degree convergence; C/B, screening; and ARC test with two degree excyclorotation. Again, these multiple  $r$ 's must be considered as trends since the associated  $F$  test of these variables indicated that the maximum correlation of .53 is not significant.

The BAC investigation (Appendix II), with data collection coming a month later than the above data, also used a sample of 12 USAF pilots. Seven of the 12 pilots had also served in the main experiment of the AFOSR study. The two investigations show correlations of similar magnitude between cyclophoria and judgment of aircraft height from the perception of the runway plane.



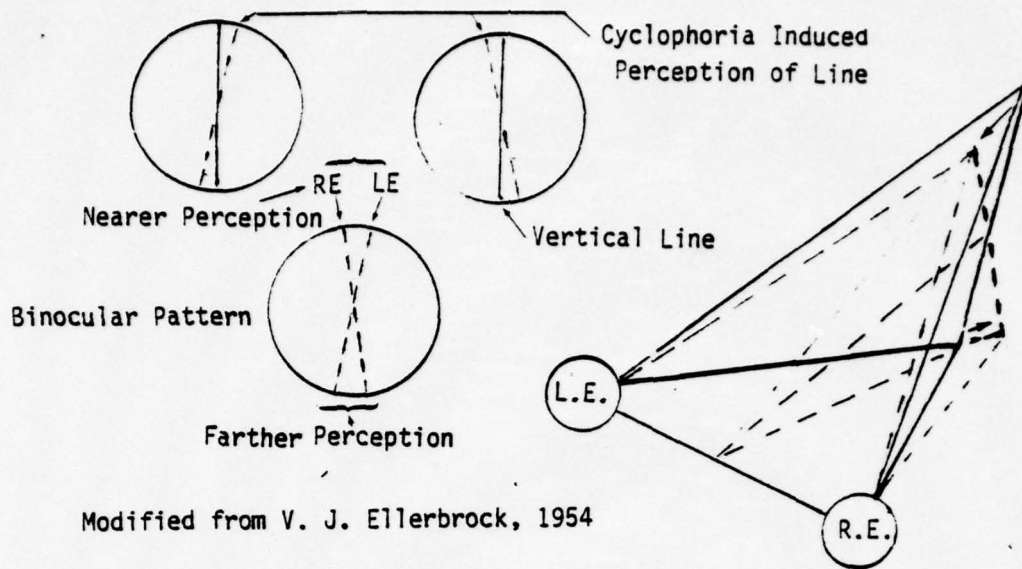

Modified from V. J. Ellerbrock, 1954

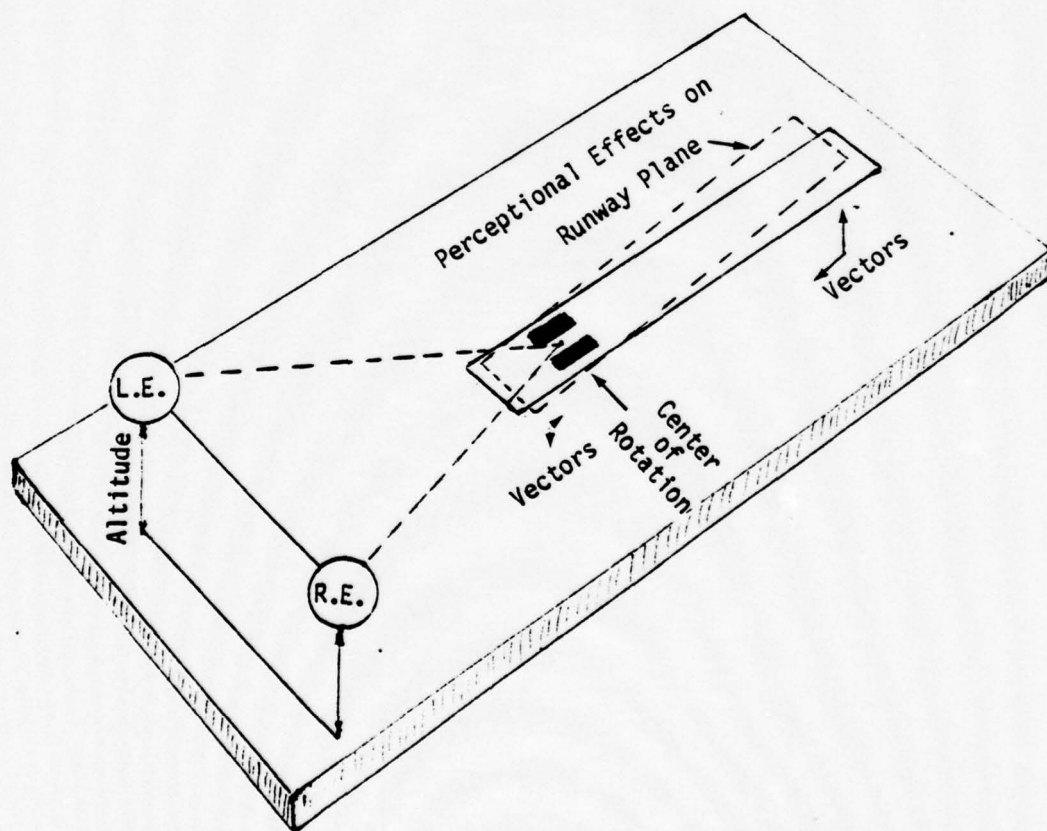

Figure 25: Conceptual Interpretation of How Cyclophoria Effects Binocular Perception of the Runway Plane

Table 10: Correlations Among Circle/Bar, ARC and Perception of the Runway Plane Test Results

		(1)	(2)	(3)	(4)	(13)	(14)	(15)	(6)	(7)
Percent High Responses	Rwy. (I) (8)	.04	-.03	.18	.22	.00	.08	.15	-.21	-.33
	Rwy (0) (9)	.29	.21	.10	.12	.25	.16	.16	-.47	-.11
	Rwy (E) (10)	-.27	-.16	-.41	-.46	-.21	-.31	-.39	-.18	-.17
Percent Correct Responses	Rwy (I,0,E) (11)	.19	.07	.37	.43	.13	.25	.33	-.03	-.11

STEP-WISE MULTIPLE CORRELATION WITH PERCENT CORRECT RESPONSES ON RUNWAY PLANE TEST

Variable	Description	Mult r
4	Circle/Bar; 10° Convergence	.43
2	Circle/Bar; 0° Convergence	.47
1	Circle Bar; Screening Test	.50
7	ARC, 2° Excyclorotation	.53

The smaller BCAC study showed a  $-.47$  correlation between negative (encyclophoric) cyclophoria and greater frequency of "higher" judgments in the perception of the runway plane photographs. The magnitude of this correlation is not significantly different from zero and the "t" for determining the significance of this  $r$  on the null hypothesis is 1.73.

Although the BCAC study is not a replication of the AFOSR work the similar correlation adds support to the observed trend that a relationship exists. The possibility does exist that the procedure of using a standard paired with variables both of which are influenced by the individual's cyclophoria, may have "put a lid" on the magnitudes of the correlations. This possibility remains as only a possibility until tested by using a different experimental procedure.

The better C/B to Runway Plane prediction by the Circle/Bar Cyclophoria Test with ten degrees of convergence than with the five degrees of convergence, and with both being better than with the zero convergence, would point to within-subject variability as one limiting factor.



## SUMMARY

This investigation had two primary objectives: (1) to determine the direction and magnitude of cyclophoria resting states in a sample of observers taken from a select population (AF pilots); and (2) to determine whether the magnitude of cyclophoria found had the potential of affecting the pilot's perception of the runway plane on final approach.

Cyclorotation of images in a stereoscope is achieved by rotating one image clockwise and the other counterclockwise about their centers. When the image is of a circle containing a vertical bar segment (the Circle/Bar test) is encyclorotated (left-eye image clockwise and right-eye image counterclockwise), the circle remains essentially vertical while the fused image of the bar inclines around a horizontal axis in the fronto-parallel plane with the top of the bar tilted toward the observer and the bottom away. Excyclorotation of the images reverses the direction of the perceived tilt.

It was hypothesized that individuals may have varying amounts of cyclophoria, due to orbital muscle imbalance or perhaps a central process, which would result in their perceiving objectively vertical Circle/Bar images as significantly tilted away from a match with the referent circle. It was further hypothesized that these "errors" in the perception of a vertical bar due to cyclophoria might generalize to errors in the perception of the plane of a runway as viewed on final approach.

The Circle/Bar test was used to screen a random sample of 30 AF pilots (C-131 and C-141 rated) as to cyclophoria resting state. The range of cyclophoria found varied from 1.34 degrees encyclophoric to 1.74 degrees excyclophoric, with a mean of .46 degrees excyclophoric. A stratified sample of 12 pilots was selected from this group for additional testing.

The Circle/Bar test was administered to these 12 pilots under 0, 5 and 10 degrees of instrument convergence. The increases in convergence significantly increased the measured cyclophoria from .01 degrees encyclophoric to .65 and .82 degrees excyclophoric.

A second, previously developed, test (the ARC test) was used to measure cyclophoria under conditions of a more complex and structured image than the Circle/Bar test. Information from the literature indicated that a more structured image, especially with horizontally arranged elements, would act as a stimulus to cyclotorsional movements of the eyes, and thus would result in an attenuation of residual cyclophoria. The ARC test was given with zero and  $\pm$  two degrees of image cyclorotation, which corresponded to  $\pm$  114 arc seconds of induced disparity into the ARC test.

Image cyclorotation produced significant effects in responses on the ARC test, with observed shifts, in the expected direction from the non-rotated condition, of 13.5 and 13.6 arc seconds for two degrees excyclo-rotation and encyclo-rotation respectively. The magnitude of this shift is only about 12 percent of the induced disparity, a reflection of the stabilizing effect of the complex stimulus pattern.

An unexpected result in the ARC test responses was an overall shift of 11.5 arc seconds (encyclophoric) in the ARC test responses as compared with the physical null. Review of data from a previous study showed a similar shift, as yet not fully understood.

Also unexpected, and not yet understood, was the low and negative correlation (-.34 N.S.) between the individual cyclophorias as measured by the Circle/Bar test and those derived from the ARC test. It is suspected that this is a reflection of a complex interplay of cyclophoria and central processing of the disparate images.

The technique of  $\pm$  two degrees image cyclorotation was also utilized in the test of the pilot's perception of the runway plane. In this test, photographic images of CGI runways, taken on a three degree glide slope, were presented in pairs, the first as a standard, non-cyclorotated (on glide slope) image and the second as a comparison with zero, or  $\pm$  two degrees of cyclorotation. The observer was asked to indicate whether the comparison image was above or below glide slope as compared with the standard.

As with the ARC test, image cyclorotation produced significant effects in the predicted direction in responses to the runway test. Encyclo-rotation of the runway image resulted in 61 percent of the responses being "high" or "above glide slope," while two degrees of excyclorotation yielded only 41 percent "high" responses. Other conditions, such as day vs. night runway scenes, three different runways, and different distances to the runway, had non-significant effects although there were some trends in the data.

These results substantiate the potential of marked cyclophoria to affect a pilot's perception of the runway plane. The pilots' individual cyclophorias and their perception of the runway plane appear to be correlated, but not in a magnitude sufficient to be statistically significant.

To further establish this relationship, a method of measurement of the perception of the runway plane with greater degrees of freedom is recommended. This should be followed by a direct test of the effects in real time with the relative motion of a visual scene in a dynamic simulator. Then if further verification appears warranted, a flight test program should be considered.



## RECOMMENDATIONS

Making the assumption that cyclophoria is important in flying and flight safety, the recommendations for further research are developed around operational problems.

### AS A POSSIBLE CONTRIBUTOR TO THE "DUCK-UNDER" PHENOMENON

Instructor pilots watch for the common tendency among pilots in initial, recurrent and transition training to depart from the established glide slope i.e., "duck under" it, on transitioning from instruments to the external visual reference. The pilot initially lowers the nose of the aircraft as though the pilot believes he is too high. A correction is almost immediately made, as though some perceptual change, or additional cues, inform him that the change in pitch and sink rate are unwarranted.

Excyclophoria exists for the majority of pilots and convergence adds through cyclotorsion some further excyclorotation. Fifteen degrees of head tilt plus ten degrees of depression of the line of sight is required to see the ADI in most transport aircraft. The ocular depression of ten degrees adds to the excyclorotation. When the pilot flying receives an auditory alert that the "runway is in sight" from his copilot, he raises his head, changes his focus from near to far, and, releases his convergence from five degrees to near parallel. In addition he must counterrotate both eyes so that the excyclorotation decreases to avoid diplopia.

The question is: Does the pilot, in the initial seconds of the transition from inside instrumentation to outside scene, see the runway plane tipped so that distant portions are raised and the near portions depressed? Such a perception could exist while the eyes are returning from the cyclotorsionally induced rotation to a balance between the true vertical and the individual's resting state. The perception of a tilted plane should dissipate rapidly with time and a conventional estimate of the runway plane should exist for the pilot in a few seconds.



### Recommendation

That a research program be undertaken to test whether pilots maintaining a compensatory tracking task on an ADI, 28 inches from the eyes and 35 degrees below the forward line of sight, for one minute, on looking up and to a distance see a tachistoscopically presented runway as tilted when: (a) the presentation of the runway is delayed 0.5, 1.0, 3.0 or 9 seconds after the pilot looks up from his instruments to a distant visual target, (b) the presentations include a variety of runways, altitudes, and distances from runway threshold, (c) magnitude estimation is used as the method of scaling, (d) the standard is a translighted picture of a 10K x 200 foot (FAA standard) runway seen from a three degree glide slope, the picture situated next to the ADI, at 28" from the eyes, (e) transition from the ADI task to the standard is signaled by a target message "look at standard" 1.5 seconds before a second message advises "runway in sight," (f) pre and post tachistoscopic exposure should be an illuminated screen of equal luminous intensity (with that of the scene) with a small fixation point located where the 1,000 foot touchdown mark will appear, (g) a minimum of 16, preferably 32, pilots with different magnitudes of positive and negative cyclophorias participate in the experiment.

### The Expected Results

The data should show: whether the immediate, intermediate and later percepts of the runway plane are the same or different; whether cyclophoria modulates only the immediate or all perceptions; whether pilots with cyclophorias differing in direction and magnitude respond differently due to such resting states; and whether with magnitude estimation scaling as a method, a higher correlation exists between cyclorotation and the perception of the runway plane.

### CYCLOPHORIA AND GLIDE SLOPE ANGLE

Short-take-off-and-landing aircraft have the capability of using both shallow and steep glide slope angles. The judgment of the horizontal-

ness of a runway plane should be made more susceptible to the effects of cyclophoria the steeper the glide slope angle. There are two vectors at work in modulating the perception of the frontal plane. When viewed from a low altitude (1) the first vector of encyclorotation will both depress the near portion of the plane and elevate the far portion, (2) the second vector will make near objects seem further away and foreshorten the apparent distance to far objects, thereby foreshortening the whole scene in the manner of a long focal-length lens. The relative "power" of the vector will shift from the foreshortening influence to the rotation of the horizontal plane as the glide slope angle increases. That is, apparent rotation with a glide slope angle of nine degrees should be relatively greater than with six degrees, which in turn should be greater than with three degrees in the amount of rotation compared with the foreshortening.

#### Recommendation

To implement a research program to study the relationship between foreshortening and inclination of the ground plane as modified by cyclorotation, for different runway visual ranges (RVRs). A possible method of implementation is to take a series of pictures of three or more CGI runways from altitudes and distances representing 2.5, 3.0, 3.5, 4.0, 5.0, 6.0, 7.0, 8.0 and 9.0 degree glide slopes. To make two sets of slides from them, one set being 2 x 2, the second 3-1/4 x 4. The first set will be installed in a projector with a zoom projection lens. The projected scene will be at a distance (10 meters) from the pilots and viewed through the cutout (plane projection) of a windshield. The pilot will be seated in front of a Troposcope or similar binocular transluminated stereoscope. The 3-1/4 x 4 slide to be mounted and viewed in the Troposcope at optical infinity, with  $\pm 4$ ,  $\pm 2$  and zero degrees of cyclorotation and zero convergence. The task for the pilot will be to select on the screen 10M away the proper glide slope and zoom magnification that matches the cyclorotated image in the Troposcope.

#### Expected Results

That these data will indicate whether the two vectors have a differential effect for different cyclorotations. Whether these effects are modified

by the pilot's individual cyclophoria, and whether different runway visual ranges that impose shortening the length of the visual segment increase the effect of the rotational vector.

#### PERCEPTION OF THE RUNWAY PLANE AND TRAINING OF VOLUNTARY CYCLOTORSIONAL MOVEMENTS

Richard Balliet and Ken Nakayama (1978), by means of a visual feedback system trained humans to make large conjugate cyclorotary eye movements at will. The range of movement increased with training at a rate of approximately 0.8 degrees per hour of practice reaching 30 degrees at the end of the training. These authors were interested as to whether training could be used to alleviate the symptoms of strabismus.

Hypothesizing that future research establishes the relationship between cyclophoria and perception of the runway plane to be critical, reliable and valid, then the modifications through training that can be made become important. We do not know whether the Balliet and Nakayama trained subjects changed in cyclophoric resting state, and if it changed, was it a stable change as a function of time with or without reinforcement. It would be most interesting if such training could be effective in giving skilled pilots a neutral cyclophoria, if that proved best for accurate runway plane perception. If such training were effective, how much reinforcement, at what intervals, etc. would be the ancillary problems.

#### Recommendation

Such visual training research would be recommended for the future, with a great caution. It should not be done with operational pilots, but with non-flying personnel, first tested with psychophysical performance tests, later trained to fly simulators for first validation investigations. It would be recommended that such training be done in a step-wise fashion, with careful observation of refractive states and measurement of visual skills to avoid causing unexpected plasticity among interdependent skills.



## BIBLIOGRAPHY

- Adams, Anthony J., and Levene, John R. Stereoscopic depth associated with cyclotorsional eye movements. Brit. J. Physiol. Optics, 217, 1967.
- Allen, M. J. The dependence of cyclophoria on convergence, elevation and American Journal of Optometry and Archives of American Academy of Optometry, 31, 297-307, 1954.
- Allen, Merrill J. The torsion component of the near reflex. American Journal of Optometry and Archives of American Academy of Optometry, 44, 343-349, 1967.
- Allen, M. J., and Carter, J. H., The torsion component of the near reflex. American Journal of Optometry and Archives of American Academy of Optometry, 44, 343-349, 1967.
- Alpern, Mathew. Kinematics of the eye. In Hugh Davson (Ed.) The Eye, Volume 3. Academic Press, New York and London, 1962.
- Ames, Adelbert. Cyclophoria. The American Journal of Physiological Optics, Vol. 7, p. 3-38, 1926.
- Anderson, C. D., and Kraft, C. L., Stereo acuity and reconnaissance. Phase I: Development of a precision chromostereopsis test and test equipment, AMRL-TR-76-112, Air Force Systems Command, WPAFB, Ohio, 1977.
- Balliet, Richard and Nakayama, Ken. Training of voluntary torsion. Investigative Ophthalmology and Visual Science, Vol. 17, No. 4, p. 303-314 April, 1978.
- Blakemore, Colin, Fiorentini, Andriana and Lamberto Maffei. A second neural mechanism of binocular depth discrimination. J. Physiol, 226, pp. 725-749, 1972.
- Borish, Irvin M. Clinical Refraction, Second Edition, Chicago, Illinois, The Professional Press, Inc., 1954.
- Bugelski, B. R. Traffic signals and depth perception. Science, Vol. 157, 1464-1465, 1967.
- Cibis, Paul A. Faulty depth perception caused by cyclotorsion. Archives of Ophthalmology, 47, 31-42, 1952.
- Crone, R. A. and Everhard-Halm, Y. Optically induced eye torsion. Albrecht von Graefe S Archiv Fur Klinische and Experimentelle Ophthalmologie, Vol. 195, p. 231-39, 1975.
- Donders, F. C., Editor: Hollandische Beitrage zu den anatomischen and physiologischen Wissenschaften, 1847, Vol. I., pp. 105, 135, and 384.

Ellerbrock, V. J. Experimental investigation of cyclofusion. American Journal of Optometry and Archives of American Academy of Optometry, Vol. 23, August, 1946.

Ellerbrock, V. J. Inducement of cyclofusional movements. American Journal of Ophthalmology, 31, p. 553-66, 1954.

Epstein, William. Perceived depth as a function of relative height under three background conditions. Journal of Experimental Psychology, 72, No. 3, 335-338, 1966.

Fry, Glenn A. Specification of the direction of regard, special report no. 1. American Journal of Optometry and Archives of American Academy of Optometry, August 1945.

Fry, Glenn A. Definition and measurement of torsion, special report no. 2. American Journal of Optometry and Archives of American Academy of Optometry, July 1947.

Fry, Glenn A. Definition and measurement of cyclophoria with converged and elevated lines of sight, special report no. 3. American Journal of Optometry and Archives of American Academy of Optometry, October 1947.

Greenberg, George. Visual induction of eye torsion, as measured with an after-image technique, in relation to visual perception of the vertical. Psychology.

Harden, Alec and Dullea, B. Strabismus. Royal Society of Medicine, Proc., 67, p. 819-22, 1974.

Harker, George S. Two stereoscopic measures of cyclorotation of the eyes. American Journal of Optometry and Archives of American Academy of Optometry, September, 1960.

Harker, George S. Apparent frontoparallel plane, stereoscopic correspondence, and induced cyclotorsion of the eyes. Perceptual and Motor Skills, Vol. 14, p. 75-87, 1962.

Harker, George S. and McLean, Jane A. Retinal correspondence and the perceived vertical. Perceptual and Motor Skills, 23, 347-360, 1966.

Hasbrook, A. H., The approach and landing. Business and Commercial Aviation, Nov., 1975.

Helmholtz, H. von: Ueber die Augenbewegungen, Heidelberg Jahrb. d. Literature, 1865, p. 258.

Helmholtz, H. von (1910): Movement of the eyes. Handbook of Physiological Optics, Vol. III (3rd ed.) English translation, Dover, New York, 1962.

Helmholtz, H. von: Treatise on Physiological Optics Vol. III, Optical Society of America, 1925, pp. 48-50.

- Hering, E.: Die Lehre vom binocularen Sehen, Leipzig, Wilhelm Engelmann, 1868; cited in Wissenschaftliche Abhandlungen, Leipzig, Georg Thieme, 1931, Vol. 2, pp. 56-62.
- Herzau, W.: Über das Verhältnis von erzwungener Vertikaldivergenz und Rollung bei der Fusion, Arch. Ophth. 122:59-74, 1929.
- Hoffman, F. B., and Bielschowsky, A.: Der Willkur entzogene Fusionbewegungen der Augen, Arch. Ges. Physiol. 80:1-40, 1900.
- Hughes, P. C. The influence of the visual field upon the visual vertical in relation to ocular torsion of the eye. Biopsychology.
- Kaufman, Lloyd and Arditi, Aries. The fusion illusion. Vision Res. Vol. 16, pp. 535, Pergamon Press, 1976.
- Kaufman, and Arditi. A reply to Fusion prevails: Letter to the Editors, Vision Res., Vol. 16, pp. 545 to 549, Pergamon Press, 1976.
- Kertesz, Andrew E. and Jones, Richard W. An objective measurement of cyclofusional response. IEEE Transactions on Bio-Medical Engineering, Vol. BME-17, No. 1 January, 1970.
- Kertesz, A. E., and Jones, R. W., Human cyclofusional response. Vision Res., Vol. 10, pp. 891-896, 1970.
- Kertesz and Jones. Human cyclofusional response. Letter to the Editors, Vision Res. Vol. 11, pp. 1357-1358, Pergamon Press, 1971.
- Kertesz, Andrew W. The effect of stimulus complexity on human cyclofusional response. Vision Res., Vol. 12, pp. 699-704, Pergamon Press, 1972.
- Kertesz, Andrew W. Some aspects of fusional information processing by the human visual system. Paper presented at the Fifth International Conference on System Sciences, University of Hawaii, January 11-13, 1972.
- Kertesz, Andrew E. Disparity detection within panum's fusional areas. Vision Res., Vol. 13, pp. 1537-1543, Pergamon Press, 1973.
- Kertesz, Andrew E. and Optican, Lance M. Interactions between neighboring retinal regions during fusional response. Vision Res., Vol. 14, pp. 339-343, Pergamon Press, 1974.
- Kraft, C. L., Night Visual Approach Research, Document D6-30131, The Boeing Company, June, 1968.
- Kraft, C. L., Rotational Tolerances in the Alignment of Stereo-Photographic-Transparencies. D180-19057-1, The Boeing Company, Seattle, Washington, 1968.
- Kraft, C. L., and Anderson, C. D. Prediction of target acquisition performance of aerial observers and photointerpreters with and without stereoscopic aids. AMRL Technical Report 73-36, Aerospace Medical Research Laboratory, WPAFB, Ohio, December, 1973a.



Kraft, C. L., and Anderson, C. D., Development of criteria for printing color reconnaissance stereo strip photography for interpretation under dynamic viewing condition. AMRL Technical Report 73-104, Aerospace Medical Research Laboratory, WPAFB, Ohio, December, 1973b.

Kraft, C. L., Anderson, C. D., Elworth, C. L., and Larry, C., Windshield Quality and Pilot Performance. AMRL-TR-77-Air Force Systems Command, WPAFB, Ohio, 1977.

Kraft, C. L., and Elworth, C. L., Flight deck work load and night visual approach performance. AGARD CP No. 56, December, 1969. Advisory Group for Aerospace Research and Development of the North Atlantic Treaty Organization.

Kraft, C. L., Elworth, C. L., Anderson, C. D., and Allsopp, W. J., Pilot acceptance and performance evaluation of visual simulation. 1976 Proceedings of the Simulation Conference U.S.N., Orlando, Fla.

Landolt, Hanbuch der Gesamten Augenheilkunde Band 2, Leipzig, 660-692, 1876.

Larry, C., and Elworth, C. L., Visual accommodation effects on Head-up display utilization, Document D162-10278-ITN, The Boeing Company, 1972.

Leibowitz, H. L., and Owens, D. A. Night myopia and the intermediate dark focus of accommodation. J. Opt. Soc. Am. Vol, 65, 1975, pp. 1121-1128.

Listing, J. B., cited by Duke-Elder, W. S.: Text Book of Ophthalmology, Vol. 1. 1932, London, Henry Kimpton, p. 596.

Mack, Arien and Chitayat, Deanna. Eye-dependent and disparity adaptation to opposite visual-field rotations. Am. Journal of Psychology, 83, p. 352-71, Sept. 1970.

Nagel, A.: Das Sehen mit zwei Augen, Leipzig, Winter, C. F., p. 51., 1861.

Nakayama, Ken and Balliet, Richard. Listing's law, eye position sense, and perception of the vertical. Vision Res., Vol. 17, pp. 453-457, Pergamon Press, 1977.

Nicholls, John V. V.. The relationship of heterophoria to depth perception in aviation. American Journal of Ophthalmology, 33, October, 1950.

Ogle, Kenneth N. The binocular depth contrast phenomenon. Am. Journal of Psychology, Vol. 59, p. 111-126, 1946.

Ogle, Kenneth N. Spatial localization according to direction. The Eye, Volume 4, Academic Press, New York and London, 1962.

Ogle, Kenneth N. and Ellerbrock, Vincent J. Cyclofusional movements. Archives of Ophthalmology, 36, 700-735, 1946.

Ogle, Kenneth N., and Madigan, Leo F. Astigmatism at oblique axes and binocular stereoscopic spatial localization. Archives of Ophthalmology.

Petrov, A. P. and Zenkin, G. M. Torsional eye movements and constancy of the visual field. Vision Res., Vol. 13, pp. 2465-2477, Pergamon Press, 1973.

Quereau, J. V. D. Some aspects of torsion. Paper presented at meeting of the College of Physicians of Philadelphia, Section on Ophthalmology, October 22, 1953.

Sullivan, Mark J. and Kertesz, Andrew E. The nature of fusional effort in diplopic regions. Vision Res., Vol. 15, pp. 79-83, Pergamon Press, 1975.

Verhoeff, F. H. Cycloduction. Tr. Am. Ophth. Soc., 1899.

Verhoeff, F. H.: Cycloduction. Tr. Am. Ophth. Soc. 32: 208-228, 1934.

Vos, J. J., The color stereoscopic effect. Vision Research, 6, 105-107, 1966.

Wright, John C. and Kertesz, Andrew E. The role of positional and orientational disparity cues in human fusional response. Vision Research, Vol. 15, pp. 427-430, Pergamon, Press, 1975.

Wulfeck, J. W., Queen, J. E., and Kitz, W. M. The effect of lighted deck shape on night carrier landing. Office of Naval Research, Arlington, Va. Technical Report N0014-72-C-0041, October, 1974.

Zoethout, W. D. Physiological Optics, Fourth Edition. Chicago, The Professional Press, Inc., 1947.

APPENDIX I

Computational Information and Settings of  
General Electric Compuscene to Provide Computer Generated  
Image for Pictorial Stimuli

All depicted sizes of runways were based on the threshold width of a 200' wide runway as seen from a 3° glide slope whose origin was 1000' down the runway (1000' mark) from two distances, 3000 and 6000 feet.

Boeing Field International (BFI)  
Runway 13, Visibility 315 miles and RVR 240,000 feet

Computer Settings (3000') Scene

x = -1495'  
y = +2604'  
Alt = 157'  
Heading = 150.15°

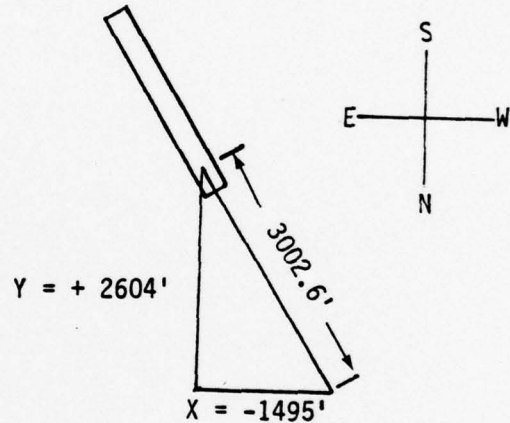

For 6000' Distance Scene

x = -3343'  
y = +5737'  
Alt = 314'  
Heading = 150.15°

Runway Length	10,000'
Runway Width	200'
G. S. Intercept	1,640'
Heading	130°

	<u>3000</u>	<u>6000</u>
Runway Width (Near)	5.6932°	2.2860°
Runway Width (Far)	0.95476°	0.7634°



APPENDIX I

Moses Lake (MWH) Runway  
 321°, Visibility 315 miles and RVR 240,000 feet

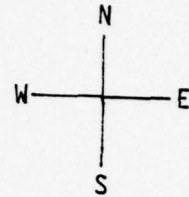

Computer Settings 3000' Scene

x = -4612'  
 y = +1478'  
 Alt = 210'  
 Heading = 342.47°

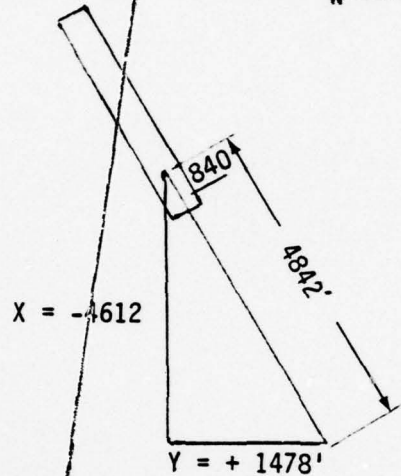

For 6000' Distance Scene

x = -8906'  
 y = +2813'  
 z = 9339.6  
 Alt = 446'

Runway Length	13,500'
Runway Width	300'
G. S. Intercept	1,840'
Heading	231°

	<u>3000</u>	<u>6000</u>
Runway Width (Near)	5.6929°	2.2856°
Runway Width (Far)	1.0474°	0.81845°

APPENDIX I

Yakima (YKM)  
Runway 270, Visibility 315 miles and RVR 240,000 feet

Computer Settings (3000') Scene

y = +2707  
x = - 985  
Alt = 131  
Heading = 290.15°

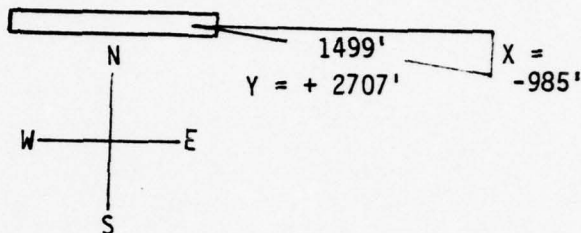

Computer Settings (6000') Scene

y = +4818  
x = -1768  
z = 5132  
Alt = 249'  
Heading = 290.15°

Runway Length	6,607'
Runway Width	150'
G. S. Intercept	1,382'
Heading	269°

	<u>3000</u>	<u>6000</u>
Runway Width (N)	5.6928°	2.2856°
Runway Width (F)	1.05990	0.8295°

## APPENDIX II

### CYCLOPHORIA AND THE VISUAL SEGMENT The Boeing Commercial Airplane Company Study (Requested by R. W. Taylor and P. M. Morton)

#### PURPOSE

To ascertain if there is a relationship between the natural resting state of cyclophoria among pilots and the perception of the horizontalness of the forward visual segment. If such a relationship exists, the quick visual change from tracking the aircraft's course on the ADI to acquiring the runway may impose a transient overestimation of the aircraft's height at the time of transition. The magnitude of the overestimation may vary with the length of the visual segment, the overestimation becoming greater the shorter the visual segment.

#### METHOD

Twelve USAF C-130 or C-141 pilots were tested for their cyclorotational resting state with the recently developed "Circle/Bar" test, a portion of an ongoing USAF OSR contract. In addition to this test, the pilots were asked to judge the relative height of an aircraft on final approach as depicted in color photographs of the Compuscene's representation of day approaches to runway 321 at Moses Lake. In making these aircraft height decisions, they were comparing the same pictures wherein the standard was perfectly registered and vertical. In the comparisons presented four seconds later, the pairs of photographs were either rotated tops inward one degree each, were vertical, or were rotated tops outward one degree each.

The paired comparison technique always presented as the standard a pair of these photographs which were identical as to scene. They were presented to both eyes in a binocular display. There was no rotation of the images for the standard, and these were illuminated for the pilot for three seconds. A four second dark phase followed; then the second (comparison) member of the pair was presented for three seconds. This



second member was presented 1/3 of the time without any rotation; one third of the time was rotated with the top of each image toward the center, encyclorotation (I). One third of the presentations were with the tops of the scenes rotated away from the centerline, excyclorotation (E). In all cases the pilots were instructed to judge the second three-second exposure of the picture as to whether the viewpoint was "higher" or "lower" than the first exposure.

There were six approach scenes presented to the pilots for their judgment of the perceived height of the aircraft. The photographic representations were Ektachrome '200' transparencies, mounted between glass and masked by Kodalith circular apertures of 15 degrees in diameter. The distances, RVR, etc. are provided in Table II-1.

TABLE II-1

Physical and Visual Parameters of the Visual Approach  
Used as Stimuli (Moses Lake, Washington, Runway 321,  
Day Scenes, Computer Generated, Full Color Images of  
Maximum Resolution of 2.47 arc min)

<u>Slide No.</u>	<u>Distance To Threshold</u>	<u>Distance To Touchdown Mk.</u>	<u>Near Visual (From Aircraft) Limit</u>	<u>RVR</u>	<u>Visual Segment</u>
1	808.5 ft.	1808.5 ft.	354 ft.	1500 ft.	1146 ft.
2	808.5	1808.5	354	2000	1646
3	808.5	1808.5	354	3000	2646
4	3002.0	4002.0	784	240,000	239,216
5	7499.0	8500.0	1664	240,000	238,336

## RESULTS

### Cyclorotation of the Eyes

The twelve USAF pilots differed as to their resting state of cyclophoria as representing the rotation of the eyes around the viewing axis, and reported as an angular difference between the right and left eye when the stimulus for focus is at infinity.

The range found among the 12 pilots was from .84 degrees (right eye rotating counterclockwise and the left eye rotating clockwise when the reference position is within the pilot's head) to +4.19 degrees. The average was +0.88 degrees and the standard deviation 1.37 degrees.

### The Pilots

The twelve pilots that participated in this BCAC investigation were all among the 30 pilots initially surveyed in the AFOSR investigation. Seven of the twelve were participants in the main AFOSR experimental study.

### Test/Retest Reliability

The participation of these twelve pilots gave us an opportunity to have a second look at the reliability of the Circle/Bar test among pilots. This "second look" was with one month of MAT activity intervening between the first and second sampling. The coefficient of correlation was + 0.74 for this test/retest of the Circle/Bar administration.

### Perception of the Runway Plane

The comparisons of the "standard" versus "zero" cyclorotation was in effect a comparison of identical images. These paired comparisons should result in nearly equal "higher" judgments and "lower" judgments. The percentages are shown in figure II-1.

AD-A070 964

BOEING AEROSPACE CO SEATTLE WASH  
CYCLOPHORIA AND PILOT PREDICTION OF THE RUNWAY PLANE.(U)  
FEB 79 C L KRAFT, C D ANDERSON, H VON TOBEL

F/G 5/10

F49620-78-C-0052

UNCLASSIFIED

AFOSR-TR-79-0830

NL

2 OF 2

AD  
A070964

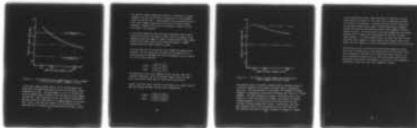

END  
DATE  
FILMED

8--79  
DDC



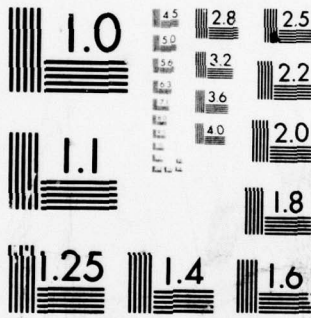

MICROCOPY RESOLUTION TEST CHART  
NATIONAL BUREAU OF STANDARDS-1963-A

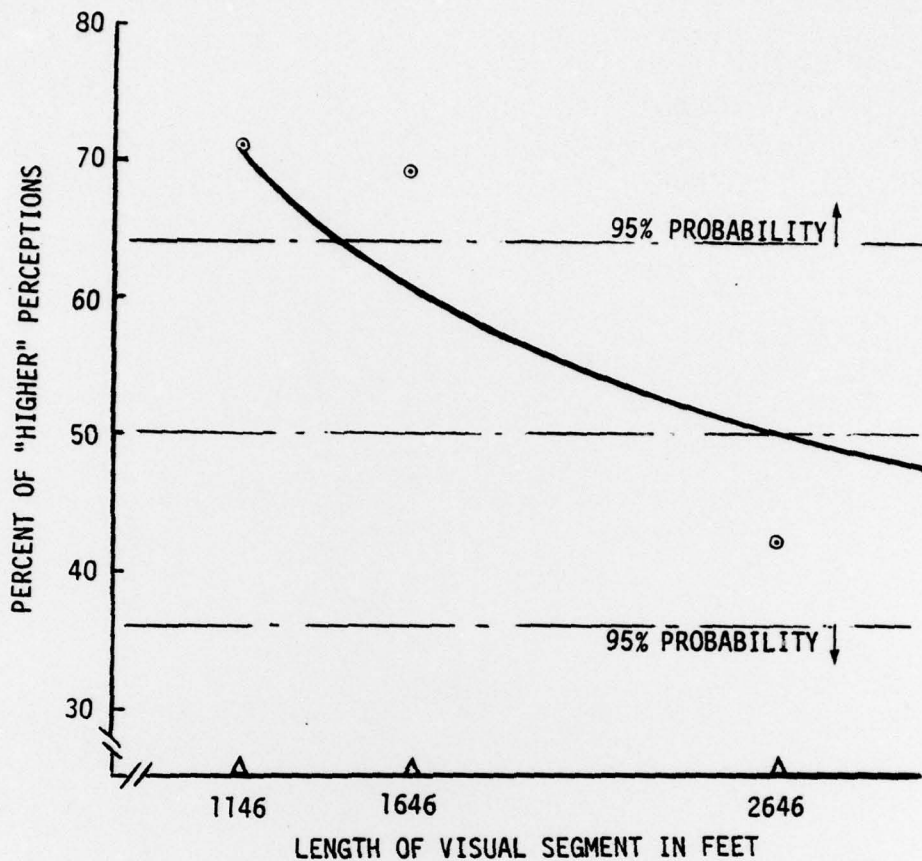

Figure II-1: The Influence of Visual Segment Length of Pilot's Judgment of the Aircraft's Height in Identical Pictures

As the visual segment becomes shorter, due to limited runway visual range (RVR), the greater the proportion of the aircraft being "Higher" perceptions by pilots. The second member of a pair of identical pictures was judged higher 71 percent of the time when the visual segment was 1146 feet. The altitude was 95 feet, the distance from threshold 808 feet, the RVR was 1500 feet and a 15 degree downward view was available. There is less than five chances in 100 replications of this experiment that a difference of this magnitude could be due to chance.

The identical imagery comparisons resulted in a proportion of "higher" judgments that could be attributed to chance for all visual segments except the shortest 1146'. Some perceptual factor associated with this short visual segment induced the pilots to give 71 percent "higher" responses, a proportion that could be attributed to chance less than five times in 100 responses.

In the paired comparisons where the second presentation had an inward rotation of the top of the images to equal a sum of two degrees it was hypothesized that the number of "higher" responses would be above chance. Conversely the outward rotation would reduce the number of "higher" responses below the number expected by chance.

The result was that for the shortest visual segment the hypothesis was supported. The CHI square test indicated that the proportion of responses grouped as diagrammed below would be expected to occur by chance only once in 100 replications.

	I	E
"Higher"	67%	29%
"Lower"	33%	71%

The same tests for the visual segments of 1646' and 2646' seen from a distance of 1808 feet, and for the 240,000' segment viewed from 4002 feet from the 1000' marker were not significantly above chance.

Another significant result occurred at the largest visual segment 240,000' when the distance was 8500' from the visual touchdown mark.

	I	E
"Higher"	62.5%	21.0%
"Lower"	37.5%	79.0%

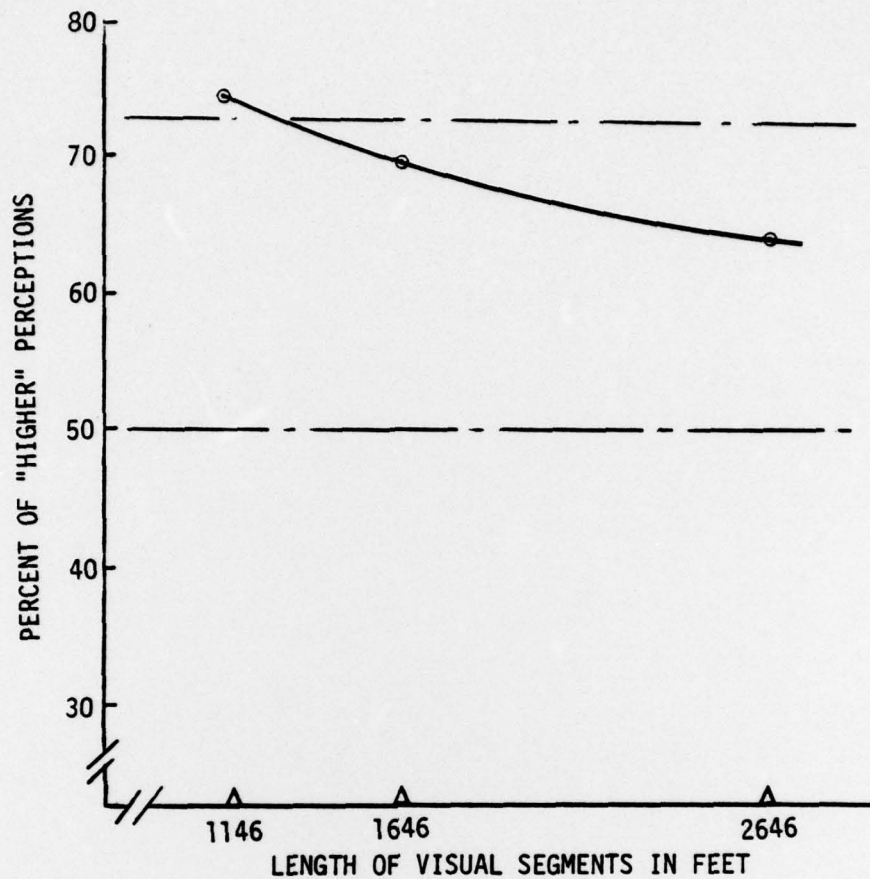

Figure II-2: The Influence of Visual Segment and Cyclorotation on Pilot's Judgment of Aircraft's Height

The hypothesis that an individual's resting state of cyclophoria would influence his perception of the frontal horizontal plane is supported by these data. With encyclorotation of the images, the frequency of "higher" judgments is increased and excyclorotation decreases the frequency of "higher" judgments. The above proportions are based on difference scores, transformed as arc sines, and treated in an ANOVA. The variable of rotation although systematic is not statistically significant due to the large individual differences among the 12 pilots. Treating each visual segment separately with a  $\chi^2$  test determined that only 1146 visual segment produced significantly different frequency of judgments of "higher."



In this instance the runway, seen from 8,500 ft. represents a smaller visual angle (3.28 degrees in the slide) than its depiction from 4002 ft. distance (5.93 degrees). It may be that small retinal image sizes of the runway imposed by the longer viewing distance may be somewhat similarly affected by cyclorotation as short visual segments viewed at nearer distances. The visual angle of the short segment was 3.87 degrees compared with 5.52 degrees and 6.62 degrees for the 1646' and 2646' visual segments. If further research were to be done, the results might show that visual segments or runway patterns must subtend larger visual angles than four degrees to overcome the potential effects of cyclorotation.

Correlational analysis reflecting the relationship between the individual pilot's resting state of cyclorotation and the differential affect on his judgment of the pitch of the forward horizontal plane was  $-.47$ . This relationship indicates that for those pilots whose resting state shows more incyclophoria, the tendency to judge short visual segments as perceptually higher than long visual segments is greater.