

AD-A070 336

STANFORD UNIV CALIF EDWARD L GINZTON LAB  
SIGNAL PROCESSORS BASED ON COMBINED CHARGE COUPLED DEVICES AND --ETC(U)  
JAN 78 P M GRANT  
GL-2774

F/6 9/3

N00014-75-C-0632

NL

UNCLASSIFIED

| OF |  
AD  
A070 336



END  
DATE  
FILMED  
7-79  
DDC

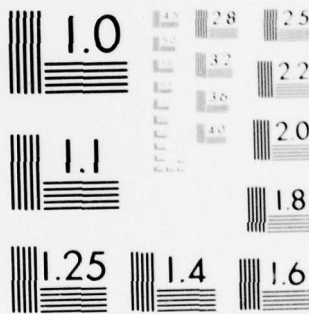

MICROCOPY RESOLUTION TEST CHART  
 NATIONAL BUREAU OF STANDARDS-1963-A

# LEVEL II

2

6

SIGNAL PROCESSORS BASED ON COMBINED CHARGE COUPLED DEVICES  
AND SURFACE ACOUSTIC WAVE DEVICES

A

by

10

Peter P. M. Grant

AD A 070336

Preprint

14  
GL-  
2774

G. L. Report No. 2774

11 January 1978

12 22p.

Contract

15

N00014-75-C-0632

DDC FILE COPY

to be presented at the  
1978 IEEE International Symposium  
on Circuits and Systems (ISCAS)  
New York City  
May 17, 18, 19, 1978

Edward L. Ginzton Laboratory  
W. W. Hansen Laboratories of Physics  
Stanford University  
Stanford, California

DDC  
RECEIVED  
JUN 22 1979  
D

**DISTRIBUTION STATEMENT A**  
Approved for public release;  
Distribution Unlimited

409640

LB

SIGNAL PROCESSORS BASED ON COMBINED CHARGE COUPLED DEVICES  
AND SURFACE ACOUSTIC WAVE DEVICES

Peter M. Grant  
Edward L. Ginzton Laboratory  
Stanford University  
Stanford, California 94305

ABSTRACT

Signal processors based on combined Charge Coupled Device (CCD) and Surface Acoustic Wave (SAW) components are reviewed. Emphasis is placed on the realization of wide bandwidth (10 MHz) Fourier transform processors, with many transform points ( $> 10^{3}$ ). Design approaches interfacing untapped CCD shift registers for time compression with SAW chirp transform processors are reported. Other designs based on multiplexed CCD, CZT's or Coherent Memory Filters are also described. These CCD-SAW Fourier analysers are shown to have application as temporal processors for Radar Doppler filtering. The potential impact of one and two dimensional spatial transform processors for Sonar beam forming is also examined.

Accession For	
NTIS GRA&I	<input checked="" type="checkbox"/>
DDC TAB	<input type="checkbox"/>
Unannounced	<input type="checkbox"/>
Justification _____	
By _____	
Distribution/ _____	
Availability Codes	
Dist	Avail and/or special
A	

## INTRODUCTION

This paper surveys the design and performance capabilities of signal processors based on combined CCD<sup>(1)</sup> and SAW<sup>(2)</sup> devices. This is accomplished by studying initially the design of a CCD-SAW adaptive filter before investigating in more detail, the design and applications of CCD-SAW Fourier transform processors. This emphasis arises because most of the studies on combining CCD and SAWs<sup>(3,4)</sup> have been concentrated at the module rather than the device level. Due to space limitations, this paper reviews only the operating principles and achievable performance of these modules.

The paper concentrates on the interfacing of untapped CCD shift registers with SAW chirp transform processors. The variable CCD clock rate permits narrowband signals to be sampled and stored with a slow clock rate. Subsequent read out at a higher clock rate, time compresses the stored information expanding its bandwidth matching it to the SAW Fourier transform processor. In addition to extending SAW processor capabilities to narrow bandwidths, time compression also permits many parallel channels to sequentially access one SAW processor.

From the companion papers at this conference it will be appreciated that SAW tapped transversal filters are essentially fixed coded devices which process complex IF coded waveforms. By contrast, the baseband clock programmable CCD, whose tap weights can be electronically adjusted, is considerably more versatile. SAW devices are attractive for applications such as Spread Spectrum communications and Radar because they currently process higher bandwidth signals (1 - 100 MHz) than CCD's (1 kHz - 10 MHz), which match closer to the system requirements.

## CCD-SAW DEVICES

In certain systems there are requirements for adaptive filters which can adjust and compensate for interference or changes in the characteristics of the propagating medium. The wideband SAW Tapped Delay Line (TDL) can be made code programmable only with microelectronic switches. Hickernell has shown at this conference that when active MOSFET's are employed to detect a SAW propagating on a silicon substrate, the gate voltage can be used to control the amplitude of the tap weight. Thus if current SAW TDLs are extended to sampling with dual 0 and  $\pi/2$  phase MOSFET taps and CCDs are incorporated to control the tap amplitudes then the design of monolithic adaptive filters is possible (Fig. 1). They could incorporate 10-100 taps to process signals with 1-25 MHz bandwidth. As such they would be ideal for channel equalization in communications and adaptive noise cancellation in Radar systems. Stopping the CCD clock would store the weights providing an alternative to the other SAW storage correlator designs reported earlier by Cafarella.

## CCD-SAW MODULES FOR SIGNAL PROCESSING

### Time Compression and Expansion

CCD-SAW modules rely heavily on the fact that simple untapped CCD shift registers can be used as buffer stores to time compress narrowband analog signals for interfacing with a fixed bandwidth SAW processor. Figure 2(a) shows, in the upper trace, a 1.2 kHz waveform which is compressed 100 times, lower trace, in a CCD shift register. Thus SAW processors with bandwidths of 1-40 MHz and time bandwidth products up to 200 can be made to operate over several decades of input signal bandwidth if the time compressed

bandwidth equals the SAW processor bandwidth. The wideband output from a processor can also be time expanded to reduce its bandwidth and interface it with low cost, low speed peripherals such as A/D converters. One advantage of time compression is that it permits a large number of separate parallel inputs to be multiplexed into a single wideband SAW processor.

This paper reviews the design of these processors and studies their applications in Fourier analysis. Time compression is also applicable to matched filtering for Spread Spectrum systems. Here the requirement to search for code timing, clock rate and carrier frequency when acquiring synchronization provides an application for parallel processing. However, it is only applicable to moderate bandwidth equipment, e.g., 10 kHz, as a large difference must be maintained between the system and SAW processor bandwidths to permit parallel processing. Figure 2(c) shows the typical performance of one channel of such a processor. Here an input linear FM waveform is detected, compressed 100 times (upper trace), modulated onto a 17 MHz carrier and correlated in a SAW chirp filter (lower trace). Such time compression matched filter processors have not yet received serious consideration for Spread Spectrum signal processing.

#### Fourier Transform Processors

Fourier transform processors are normally implemented digitally with the FFT computer based algorithm. Extensive computation is required for large transforms, e.g., those whose time bandwidth product or number of transform points,  $N$ , exceeds 1024. This restricts the processing speed to several kHz. Dedicated hardware processors can increase the data throughput by several orders of magnitude but ultimately they are expensive and power consuming. This has led to the development of analog CCD

and SAW Fourier transform processors based on the chirp transform<sup>(5,6)</sup> algorithm.

In the SAW spectrum analyzer,<sup>(5)</sup> real time processing is achieved by multiplying the input signal with a chirp. Subsequent convolution in a SAW chirp filter matched to the multiplier chirp yields the spectrum of the input signal. If the chirp multiplier has bandwidth  $B$  Hz and duration  $T$  s, the SAW chirp filter requires a time-bandwidth product of  $2B \times 2T$  to permit analysis of a signal bandwidth  $B$  Hz with a CW frequency resolution of  $T^{-1}$  Hz. With SAW components,  $B$  and  $T$  are fixed during the design to one point within the bounds of Fig. 3. The CCD Chirp-Z-Transform (CZT)<sup>(6)</sup> is almost as flexible as the FFT because the externally programmable clock waveform permits it to cover, within the bounds of Fig. 3, several octaves of bandwidth. However, CCD CZTs are restricted to 500 transform points by the four gain matched parallel channels of tapped CCD which are required to implement the complex processing.<sup>(6)</sup> Single chip 32 point processors have only been reported this year. This restriction has led to the marriage of the less sophisticated untapped CCDs, which are easier to fabricate, with the high performance SAW chirp transform processor.

#### CCD-SAW Spectrum Analyzers

Figure 4 shows the schematic of a CCD-SAW spectrum analyzer module. The input signal is sampled at a rate  $R$  Hz as dictated by the required analyzer bandwidth, storing a signal record in the  $N$  stage shift register. When full, the clock rate is increased by a factor  $S$ , reading out the signal at  $S \times R$  Hz, matching it to the SAW analyzer bandwidth  $B$  Hz. This reduces the effective resolution of the SAW processor from  $T^{-1}$  Hz



to  $(S \times T)^{-1}$  Hz . Thus by varying S, the CCD-SAW spectrum analyzer resolution can be made electronically programmable extending it beyond the overlap into the CCD region of Fig. 3. Dual channel synchronous CCD time compressors are required to handle complex input data. Demodulation of the input signal using local oscillators in phase quadrature permits identification of positive and negative frequencies relative to the demodulation frequency,  $f_1$  . Here,  $f_1$  sets the analyzer center frequency and progressive variation of the synthesized LO frequency,  $f_1$  , and time compression factor, S , permits the processor to 'zoom-in' for detailed analysis of spectral lines over any desired part of the SAW analyzer bandwidth. After analog time compression, the CCD output is modulated on a fixed carrier,  $f_2$  , at the SAW analyzer input frequency.

The demonstration analyzer is based on SAW chirp filters fabricated on ST, X quartz at center frequency 17 MHz with 2 MHz chirp bandwidth and 20  $\mu$ s dispersive delay. This permits analysis of 1 MHz signal bandwidth in 10  $\mu$ s with a frequency resolution of 100 kHz. The time compressor employed GEC MA 318 CCD analog shift registers. The performance of the processor is demonstrated in Fig. 5 when analyzing a modulated signal in the short wave band. The input test signal was a 15.432 MHz carrier, tone modulated at 400 Hz rate. Figure 5(a) shows the operation of the basic SAW spectrum analyzer without time compression, ( $S = 1$ ), with  $f_1 = 15.000$  MHz. The input signal frequency is measured as  $(15.000 + 4.3 \times 0.1)$  MHz, i.e., 15.43 MHz. Progressive resetting of the synthesizer and time compression factor produces Fig. 5(b) which clearly shows the modulation sidebands at  $\pm 400$  Hz.

This time compression technique can be extended to permit real time, high resolution, spectrum analysis over the full bandwidth of the SAW analyzer.<sup>(7)</sup> The input signal must be demodulated by  $S$  offset local oscillators to generate contiguous frequency bands which cover the whole SAW bandwidth. The individual down-converted signals are then input to  $S$  parallel CCD time compressors which sample at a rate  $B/S$  Hz and are read out at a rate  $B$  Hz such that a SAW spectrum analyzer of bandwidth  $B$  Hz and chirp duration  $T$  s can sequentially access the  $S$  channels to yield a frequency resolution of  $(S \times T)^{-1}$  Hz over the full bandwidth  $B$  Hz.

With devices available, this technique permits an increase in the effective time bandwidth  $TB$  product of a SAW spectrum analyzer by 1-2 orders of magnitude. In this way a modest SAW spectrum analyzer with a 4 MHz real time bandwidth and 40 kHz frequency resolution ( $BT = 100$ ) can be extended to 2 kHz frequency resolution ( $BT = 2000$ ) with only 20 time compression channels. Here the overall  $TB$  considerably exceeds that of the individual devices, extending this CCD-SAW analyzers capabilities vertically from the overlap region of Fig. 3. The concept of interfacing a large number of CCD IC's into one SAW processor is not necessarily expensive as the CCD cost will decrease dramatically with increased usage.

Another technique, which uses broadly similar hardware, implements the Fourier transform in modular format with CCDs. By factorizing<sup>(8)</sup> the number of transform points  $N$  into  $N = P \times L$  the processor can be reorganized as shown in Fig. 6. It comprises a serial to parallel multiplexer,  $P$  individual  $L$  point CCD CZTs each operating at  $1/P$  the overall processor bandwidth, followed by a parallel to serial multiplex in a SAW diode convolver (see Grudkowski this session) operating at the

full processor bandwidth. Thus a 64 tap 25 MHz bandwidth convolver interfaced with 64 individual  $L = 32$  point CCD CZTs implements a 2048 point processor with 25 MHz bandwidth and 12.5 kHz resolution. Although it is anticipated that this processor would possess a dynamic range comparable to earlier time compressed design it does offer increased overall bandwidth.

#### DOPPLER FILTERING

One important application for CCD-SAW processor is Radar Doppler filtering.<sup>(9)</sup> This is a two-dimensional problem as the Radar return must initially be ordered into range cells. A history of returns is then built up in each cell for spectrum analysis. CCDs have shown how compact analog circuitry can be used to implement the corner tuning memory, Fig. 7, for reordering the data. Here each Radar return is loaded horizontally into the top serial CCD, and each PRP the new data is clocked vertically into the stack. The Doppler from a target is then available as a signal in the vertical register corresponding to the appropriate range cell. If these registers are read out serially at high speed they can all be sequentially accessed to one SAW processor for spectrum analysis, Fig. 7. With currently available devices it is possible to achieve 40 Hz resolution of a  $\pm 2$  kHz Doppler signal over 100 range cells.

An alternative solution, which is applicable in high resolution search Radar, is to use a SAW TDL correlator to order the returns into range cells, and to follow this by a parallel bank of CCD coherent memory filters,<sup>(10)</sup> Fig. 8. These later filters, perform the Fourier transform with an untapped CCD delay line, compensating amplifier and offset oscillator, in a closed loop recirculating system,<sup>(10)</sup> Fig. 8. Hence, they are simpler to

construct and can be duplicated easily for parallel operation. As this processor incorporates a correlator, it can also match filter at IF while it orders by range cell. Coherent memory filters have been demonstrated in both SAW and CCD technologies. The latter can resolve to 200 Hz a  $\pm 5$  kHz Doppler.

#### BEAMFORMING

Further potential applications for the Fourier transform processor occur in beamforming and beamsteering. The angular power spectrum or beam pattern for an array of transducer elements is controlled by the Fourier transform of the autocorrelation function of the aperture distribution across the array. Thus, in a receiving array the beam pattern can be synthesized by taking the Fourier transform of sampled signals from each transducer. "Shading" can be introduced across the transducer array by weighting in amplitude and phase the input data to synthesize the desired beam pattern. By contrast to dedicated hardware time delay beamsteering systems, the  $N$  point Fourier transform processor simultaneously forms  $N$  beam patterns from an  $N$  element hydrophone array.

The beamformer scheme shown in Fig. 9, operates by downconverting to baseband and simultaneously sampling, in phase and quadrature, the transducer outputs and loading them in parallel into two analogue stores. Figure 9 shows only the in phase (real) channel. Integrated CCDs have been proposed for this application.<sup>(11)</sup> Beamforming is accomplished by serially reading out the  $N$  stored samples at a rate at least  $N$  times the input sample rate for subsequent analysis in a SAW Fourier transform processor. The  $N$  point processor analyzes these stored signals to yield outputs corresponding to  $N$  individual angular beam patterns. One is on

boresight, there are  $N/2 - 1$  at both positive and negative incidence angles, while the last beam position combines the  $\pm 90^\circ$  maximum viewing angles. The beam incident at angle  $\theta$  introduces a delay between adjacent transducers of  $\frac{d \sin \theta}{c}$  where  $d$  = transducer spacing and  $c$  = velocity of propagation. If the sonar is operating at center frequency  $f_o = \omega_o/2$ , this delay introduces a phase change

$$\frac{\omega_o d \sin \theta}{c}$$

radians between stored analogue samples. Thus the output of the processor provides the incident beam angle not directly in  $\theta$  but in  $\sin \theta$ , Fig. 9. A beamformer incorporating 64 elements and  $\lambda/2$  spacings would provide 32 usable beams of approximately  $2^\circ$  beamwidth over a  $\pm 30^\circ$  angle about the boresight. The Fourier transform based beamformer requires signals of duration  $\frac{Nd \sin \theta}{c}$  to permit the memory to sample the phase variation across the transducer array. This restricts it to narrowband systems when compared with the time delay beamformer<sup>(11)</sup> approach. Thus, the Fourier transform based beamformer offers simultaneous multiple beam synthesis at the expense of range resolution.

#### MULTI-DIMENSIONAL TRANSFORM PROCESSORS

When additional processing is required to perform Doppler or matched filtering of the received signals, the beamformer must be followed by a "corner turning" memory, Fig. 7. Doppler filtering can now be performed in a post-processor attached to each individual beam. Alternatively the signals can be type compressed in a CCD prior to processing in a SAW Fourier transform device. Such CCD-SAW two-dimensional Fourier transform processors

can calculate the spatial transform before the temporal transform<sup>(7,8)</sup> or they can process in the reverse order.<sup>(12)</sup>

The incorporation of additional processors<sup>(8)</sup> achieves further sophistication permitting circular transducer arrays to be accommodated. In addition, matched filtering can be added for determination of target range. Thus there is virtually no end to the complexity of the processor when multi-dimensional transforms are attempted. However, it is the advent of the compact analog CCD-SAW Fourier transform processor which permits such complex schemes for real-time processing of Sonar waveforms to be considered.

#### CONCLUSION

This paper has illustrated how combined CCD-SAW signal processors can achieve performance capabilities which open up new application areas not previously possible with individual CCD or SAW components. Their application to spectrum analysis provides bandwidths exceeding those of current digital FFT processors (i.e., > 100 kHz) while retaining the high probability of signal intercept not obtained with wideband swept frequency analyzers. The engineering advantages of low power and low volume are of particular significance in airborne Radar Doppler filtering and in sophisticated Sonar applications such as unmanned submersible and small commercial systems. In this latter area the multi-dimensional transform which offers simultaneous beamforming, Doppler filtering, matched filtering and range measurement, promises a bright future for the analog Fourier transform processors reported here.

ACKNOWLEDGEMENTS

The author wishes to acknowledge the help of colleagues at the University of Edinburgh, Scotland, particularly Dr. M. A. Jack, for his assistance with the detail of this manuscript. This work was supported predominantly by the British Science Research Council. Partial support from the Office of Naval Research under Contract N00014-75-C-0632 is also acknowledged.

#### REFERENCES

1. D. D. Buss, et al., "CCDs for Analog Signal Processing," IEE Conference Proceedings, No. 144, pp. 17-23, September 1976.
2. J. D. Maines and E.G.S. Paige, "SAW Devices for Signal Processing," Proc. IEEE 64, #5, pp. 639-652 (May 1976).
3. M. A. Jack, "CCD/SAW Combination Improves Radar Design," Microwave Systems News 7, #10, pp. 109-114 (October 1977).
4. J.G.B. Roberts, "CCD and SAW: Friends or Foes," IEE Conference Publication No. 144, pp. 53-60, September 1976.
5. H. M. Gerard and O. W. Otto, "Performance of a Programmable Radar Pulse Compression Filter Based on the Chirp Transform with RAC Filters," Proceedings of the 1977 IEEE Ultrasonics Symposium.
6. R. W. Broderson, et al., "A 500-stage CCD Transversal Filter for Spectral Analysis," IEEE Trans. ED-23, #2, pp. 143-152 (February 1976).
7. P. M. Grant and M. A. Jack, "Design and Applications of CCD-SAW Fourier Transform Processors," 1977 IEEE Ultrasonics Symposium, Paper I4.
8. J. M. Alsup, et al., "Transform Processing Using SAW Devices," IEEE Proc. ISCAS, pp. 693-697, 1976.
9. J.B.G. Roberts, "Radar Doppler Processing Using CCD and SAW Devices," Electronics Letters 11, #22, pp. 525-526 (October 1975).
10. J. D. Jackson, et al., "A CCD Delay Line Doppler Analyzer," Agard Conference Proceedings, CPP-230, October 1977.
11. R. D. Melen, et al., "CCDs for Holographic and Beamsteering Sonar systems," Acoustical Holography, Vol. 7, Plenum Press (1977), pp. 461-473.



12. M. A. Jack and P. M. Grant, "Two-Dimensional Transform Processor for Sonar Beamforming Using CCD and SAW Devices," *Electronics Letters* 13, #3, pp. 65-66 (3 February 1977).

ADDITIONAL REFERENCES FROM THIS CONFERENCE

- A. F. S. Hickernell and H. J. Bush, "Monolithic Programmable SAW Transverse Filters"
- B. J. H. Cafarella, "Acousto-Electric Surface Wave Devices for Programmable Signal Processing"
- C. T. W. Grudkowski and T. M. Reeder, "Application of Nonlinear Tapped Delay Lines to High Speed Signal Processing"

## FIGURE CAPTIONS

- Figure 1 Proposed monolithic CCD-SAW adaptive transversal filter.
- Figure 2 Time compressed matched filter performance.
- Figure 3 Current performance bounds for individual CCD and SAW  
Fourier transform processors.
- Figure 4 Variable resolution spectrum analyzer design.
- Figure 5 Variable resolution spectrum analyzer performance.
- Figure 6 Modular CCD-SAW Fourier transform processor (after Alsup,  
reference 8).
- Figure 7 Radar pulse Doppler analyzer (after Roberts, reference 9).
- Figure 8 Radar pulse Doppler analyzer (after Jackson, reference 10).
- Figure 9 Schematic of CCD-SAW Sonar beamformer.

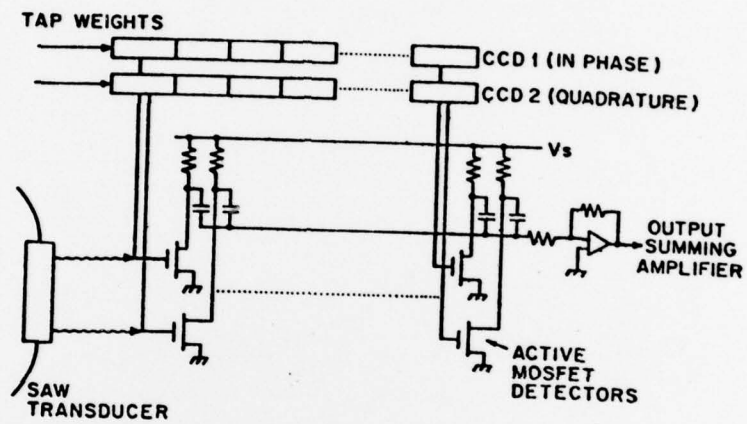
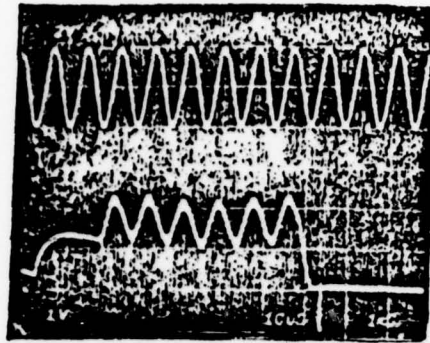

FIGURE 1



Input at 1.2 KHz

Output at 120 KHz after 100 times compression

(a)

SINGLE CHANNEL COMPRESSOR

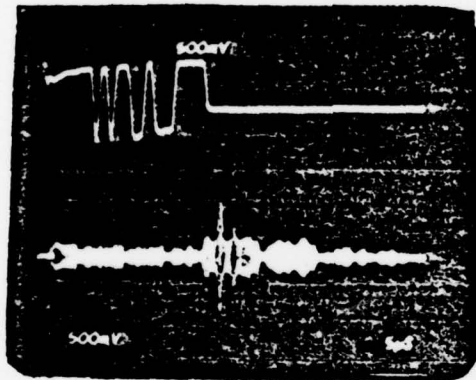

Baseband compressed output

Autocorrelation function of 15 bit PN code at 240 MHz

(b)

TIME COMPRESSOR PLUS SAW CONVOLVER

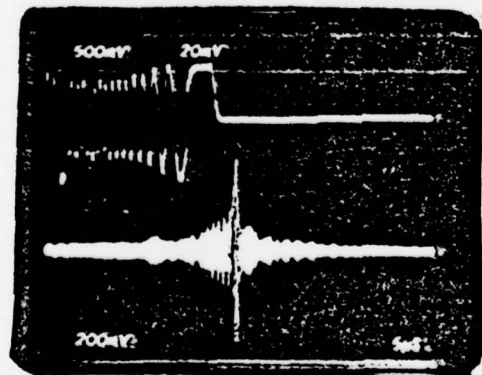

Baseband compressed output

Autocorrelation function of linear FM input at 17 MHz

(c)

TIME COMPRESSOR PLUS SAW CHIRP FILTER

FIGURE 2

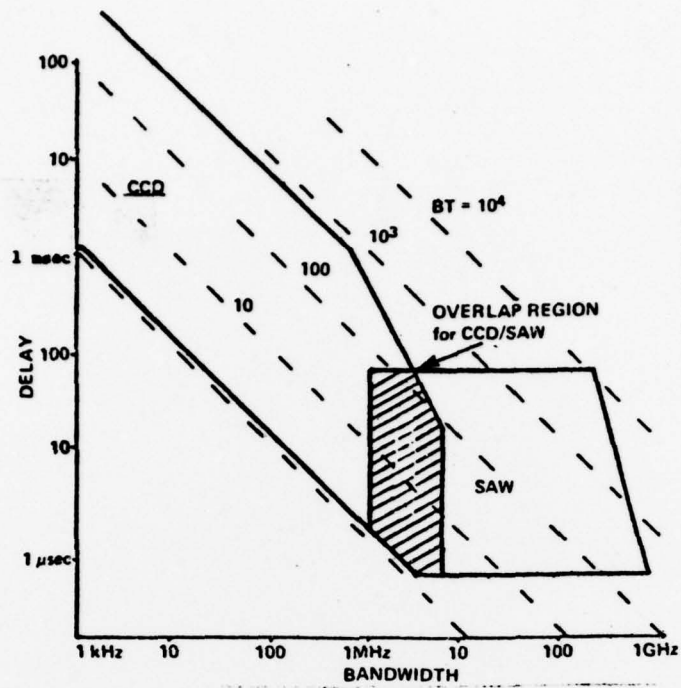

FIGURE 3

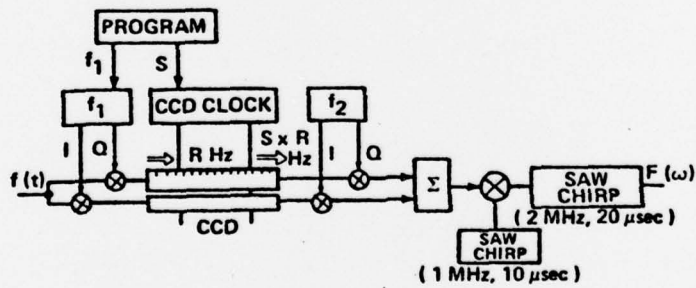
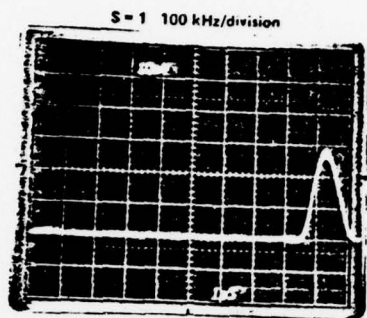
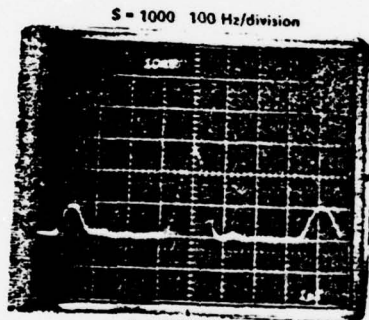

FIGURE 4



f<sub>1</sub> = 15.000 MHz



f<sub>1</sub> = 15.432 MHz

FIGURE 5

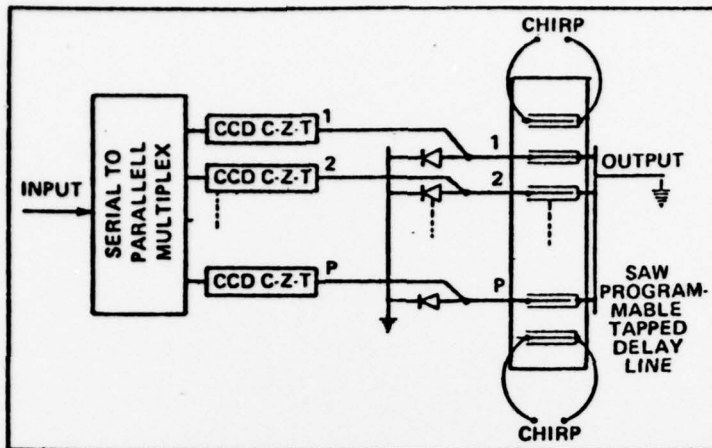

FIGURE 6

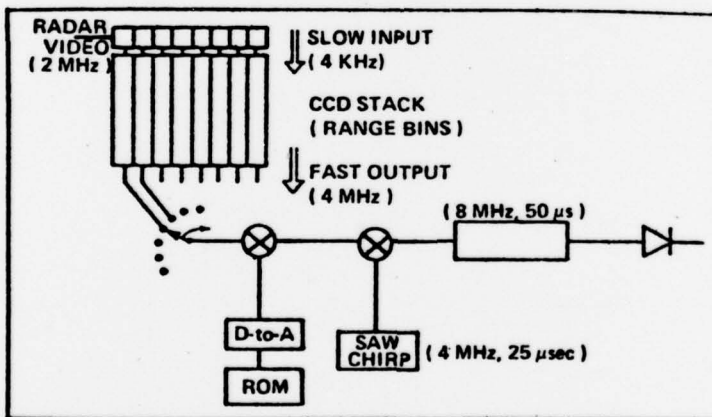

FIGURE 7

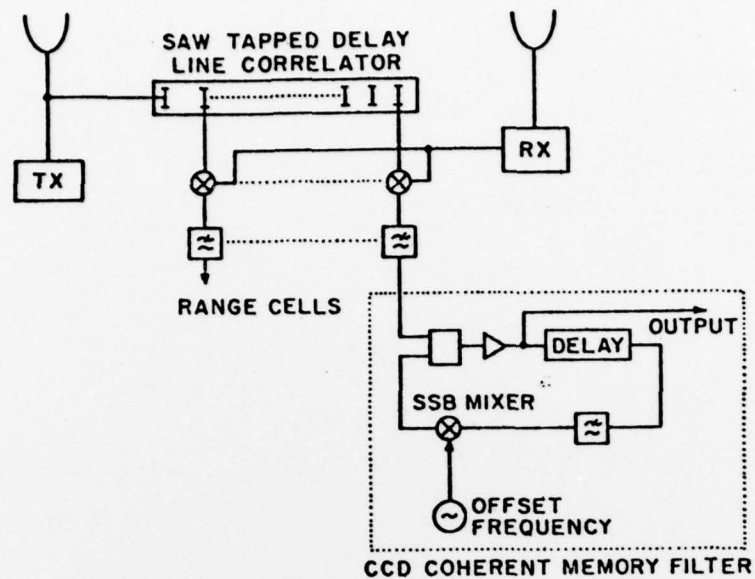

FIGURE 8

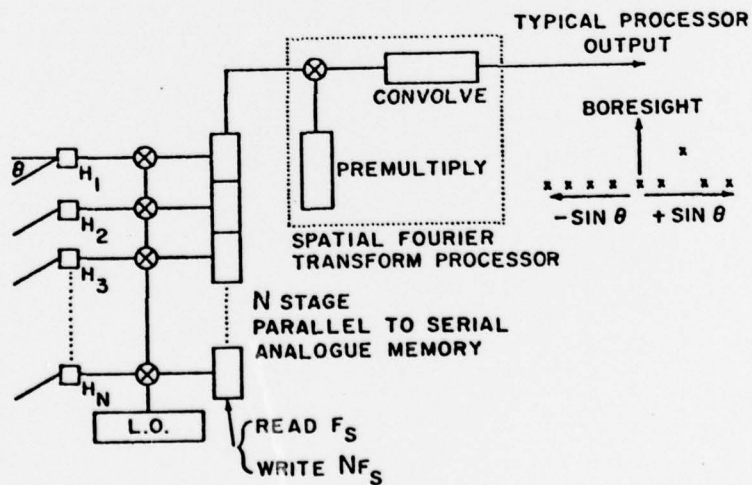

FIGURE 9