

UNCLASSIFIED

AR-001-425

DEPARTMENT OF DEFENCE

DEFENCE SCIENCE AND TECHNOLOGY ORGANISATION

ELECTRONICS RESEARCH LABORATORY

TECHNICAL MEMORANDUM

ERL-0050-TM

A MICROPROCESSOR BASED IMAGE STORAGE AND ANALYSIS FACILITY
FOR INFRARED SIGNATURE MEASUREMENT AND IMAGE PROCESSING

G.V. Poropat

S U M M A R Y

The design and operation of a microprocessor based data acquisition system is described. The system is capable of digitising and storing a frame of pictorial information from an AGA Thermovision and provides facilities for the analysis of the stored information. Transfer of the stored information to the IBM 370/168 can be achieved at high speed and sophisticated processing applied to the stored data. The use of a microprocessor as the controlling unit has allowed the implementation of some analysis and processing facilities at the experimental site.

November 1978

Approved for Public Release

POSTAL ADDRESS: Chief Superintendent, Electronics Research Laboratory,
Box 2151, G.P.O., Adelaide, South Australia, 5001.

UNCLASSIFIED

TABLE OF CONTENTS

	Page No.
1. INTRODUCTION	1
2. GENERAL DESCRIPTION	1 - 2
2.1 System requirements	1 - 2
2.2 Basic system design	2
3. HARDWARE DESCRIPTION	3 - 5
3.1 The Central Processor and Direct Memory Access Controller	3
3.2 System memory	3 - 4
3.3 Teletype/Terminal Communications and Memory, Input/Output Selector	4
3.4 Tektronix Display Interface	4
3.5 Remote Data Station Interface	4
3.6 MFE 250B Cassette Data Storage Unit Interface	4 - 5
3.7 AGA Thermovision Interface	5
4. PERIPHERAL SUPPORT EQUIPMENT	5 - 6
4.1 Cassette data logger	5 - 6
4.2 Remote data station	6
4.3 Tektronix display unit	6
5. SOFTWARE DESCRIPTION	7
6. APPLICATIONS	7 - 8
7. CONCLUSION	8
8. ACKNOWLEDGEMENTS	8
REFERENCES	9
TABLE 1. SYSTEM COMMANDS AND FUNCTIONS	10

LIST OF FIGURES

1. Functional layout of the data acquisition system
2. Circuit diagram of the CPU/DMA Controller Board
3. Circuit diagram of the Remote Data Station Interface
4. Circuit diagram of the Cassette Tape Storage Unit Interface
- 5(a). Video amplifier and analogue to digital converter for the AGA thermovision interface
- 5(b). Timing controller for AGA thermovision interface

6. Simplified flowchart of command input, frame acquisition and display
- 7(a). Algorithm for video contrast enhancement
- 7(b). Flowchart for implementation of the algorithm
8. Effect of contrast enhancement for various values of multiplier (n)

1. INTRODUCTION

The design, performance and use of an image storage and processing system designed to provide a facility for the analysis of data obtained using line scanned infrared imaging systems and the development of signal processing algorithms for the enhancement of imagery obtained using these systems is described in this paper. The system has been constructed so as to be usable with a number of imaging devices by utilising the power and flexibility afforded by the use of a microprocessor. The configuration adopted requires only relatively minor changes in software and hardware to enable the system to be used with devices of differing display formats such as the AGA Thermovision and the DRCS Sector Scanner.

Prior to the development of this system quantitative information from imagery obtained using these devices was derived from photographs of the images or from cathode ray oscilloscope displays of the video signal. Photographs of the displayed image were analysed by scanning the negative with a microdensitometer to obtain the video signals, and to obtain accurate results correction had to be made for the non linearities of the display tube and photographic film. Direct viewing and recording of the video signal via a CRO display eliminates the need for correction for these non linearities, but is limited in the amount of information which can be retrieved.

Computer aided analysis of the data from line scanned systems obtained using these techniques is limited by the low throughput, due to the amount of effort required to translate the information to a medium suitable for input to a computer. The development of signal processing algorithms to enhance the information capability of line scanned imaging systems and to improve the analysis of data obtained using these systems also required the development of high speed data processing capabilities. A prototype system(ref.1) was constructed to be used with the AGA Thermovision which digitised and stored one complete frame of the AGA imagery and provided a hard copy (via a chart recorder) of the video signal. This system also provided facilities (via a WANG programmable calculator) to output the complete frame on punched paper tape for input to the DRCS Central Computer and stored the digitised frame on cassette tape.

The use of paper tape however, was limited by the speed of the available tape punch which required approximately 20 min to punch a complete frame. Although data could be obtained in a form suitable for computer input - processed data from the computer could not readily be displayed.

The development of microprocessors and the availability of a Remote Data Station for input of data to the Central Computer from a remote site and retrieval of data from the computer has enabled the development of an image acquisition system which provides more facilities for data analysis and is not restricted in its application to the AGA Thermovision. The system has been designed to allow upgrading of its facilities as the need arises by the use of a modular, bus oriented design approach.

2. GENERAL DESCRIPTION

2.1 System requirements

The required functions of the image acquisition and analysis system are:

- (a) Storage of a frame of pictorial information from the imaging source,
- (b) Non destructive readout and display of the stored frame for verification,
- (c) Storage and retrieval of a frame on magnetic tape,
- (d) Transfer of data to and retrieval of data from the DRCS Central Computer,
- (e) Isotherm facilities for analysis of data,

- (f) Facilities for locating and evaluating individual data words within the stored frame,
- (g) Facilities for output of a section of the frame as an 'A' scan on a CRO or as permanent record via a chart recorder,
- (h) The ability to implement signal processing algorithms on the system to aid in their development and evaluation.

2.2 Basic system design

The system is designed around an Intel 8080A microprocessor. An 8 bit machine was chosen after consideration of the video signals to be analysed indicated that digitising to 8 bits would provide adequate resolution and keep the quantisation error below the inherent noise of the imaging systems.

An acceptable image can be generated from 4 bit data but this does not provide the accuracy required for analysis of the imagery.

The instructions upon which the 8080 operates are stored in electrically programmable Read Only Memories and the data obtained is stored in static M.O.S. Random Access Memories (RAM). The system has been designed (for the most part) around a common bus structure which has simplified the layout of the system and will allow future system expansion and changes. The bus structure has three components, the control bus (which controls CPU access to memory and input/output devices), the address bus and the data bus. The system design has been arranged so that the major functional units are constructed on printed circuit card modules which plug into the system bus.

The address structure used allows the microprocessor to access 48 Kbytes of memory (a mixture of EPROM and RAM) but the initial configuration only requires 16 Kbytes of memory (6 Kbytes of EPROM and 10 Kbytes of RAM). The initial configuration is sufficient to store the routines controlling data acquisition, display, transfer to/from the central computer, storage/retrieval from tape and to allow the storage of one frame of video information from the AGA Thermovision (7200 bytes). Expansion of the RAM will allow the storage of multiple frames or the storage of all or part of the frame from the DRCS Sector Scanner.

The data acquisition process is performed by an Intel 8257 Direct Memory Access (D.M.A.) Controller since the sampling rate to be used (156.25 kHz for the AGA Thermovision(ref.2)) is too fast to allow the microprocessor (which has a 2 μ s cycle time) to be used to control data transfer into the RAM. The use of the DMA Controller with Random Access Memories which have a minimum write cycle time of 270 ns will allow the use of sampling rates up to 2 MHz.

Communication with peripheral devices such as the tape storage facilities, the Remote Data Station and the Display Unit is achieved using a mixture of general purpose Programmable Interfaces (using the Intel 8255 Programmable Peripheral Interface) and special purpose interfaces.

The stored frame is displayed on a Tektronix 604 Monitor via a separate rotating serial memory which is loaded, under the control of the 8080, with the data which has been stored in the RAM. This effectively allows the display of one frame while another is being acquired.

Figure 1 illustrates the overall system layout. This illustrates the system as it has been configured to operate with the AGA Thermovision. The user communicates with the system via a standard Teletype or Visual Display Unit and Keyboard.

3. HARDWARE DESCRIPTION

3.1 The Central Processor and Direct Memory Access Controller (figure 2)

This is the central unit of the system and consists of an 8080A micro-processor, with an 8228 system controller and an 8257 D.M.A. Controller. All address bus outputs are buffered using 8212 buffers. During all phases of system operation other than the actual data acquisition phase the 8080 controls the system address, data and control busses, and the data bus is buffered by the 8228 (as is the control bus). The 8257 is programmed via the 8080 prior to the data acquisition phase and controls the system bus during the acquisition phase. In the system the 8257 is operated in the 'memory-mapped' mode and the unit has been designed for one channel of data input only - the 8257 only drives the data bus while outputting the address of the data destination during D.M.A. - the data is passed to the system via the tri-state buffers which are used to input data from the Analogue to Digital Converter.

The address of the D.M.A. controller in the 'memory-mapped' mode is FFFXH (where X is a hexadecimal digit) and this is derived by partially decoding the system address bus, which results in addresses 0000 to BFFFH being available for memory. This represents 48 Kbytes of available memory.

The 8257 is operated in the 'burst' mode where each line from the imaging device is passed to the RAM in an unbroken stream. After each line, control reverts to the 8080 which checks to see if the end of frame has been loaded and if not programs the 8257 for the next line and relinquishes control of the bus. The routine which controls the 8080 during programming of the 8257 is accessed via an external interrupt, and thus the data transfer is effectively under the control of the imaging device while the data format is under software control. To reconfigure the system for another device requires a suitable A/D converter and timing controller for the device and minor software changes.

When used with the AGA Thermovision 90 lines of video data (there are 95 lines of active data) are processed with 80 samples per line taken at a sampling rate of 156.25 kHz (ref.2).

3.2 System memory

(a) Read Only Memory (Program Storage)

The instructions on which the 8080 operates are in general stored in 2708 electrically programmable read only memories since most of the routines used are required as permanent installations. 8 Kbytes of read only memory storage are used (the basic programs occupy 5 Kbytes) and these reside on one printed circuit card. This card was not designed as part of the overall system but was part of the 'Mulloka' card set and so does not conform to the bus structure of the rest of the system. The PROM card is selected by one of eight memory select lines which are used to partition the memory into 8 Kbyte blocks. These memory select lines are generated on the Printed Circuit card which carries the Universal Synchronous/Asynchronous Receiver/Transmitter which communicates with the teletype. The individual addresses on the PROM card are generated by applying bits 0 to 9 of the address to the PROMs and decoding bits 10, 11 and 12 on the card to act as chip select lines for the PROMs.

(b) Random Access Memory (Program and Data Storage)

This memory is divided into two functional parts. One of these is compatible with the overall bus structure of the system and is composed of 1 Kbyte 'pages' of memory (with newly available RAMs these can be upgraded to 4 Kbyte pages) on printed circuit cards which plug into the main system bus. The second consists of two 8 Kbyte 'pages' of memory which are constructed on available S-100 bus compatible printed circuit boards. These are carried on a separate 'mother board' which is

interfaced via a simple unit to the main system bus. This unit generates the input and output data busses used by the S-100 system from the composite system data bus and generates the necessary control signals for the S-100 memory boards. The memory will be configured in the final version around 20 Kbytes of R.A.M. using the 4 Kbyte memory boards which are compatible with the backplane structure.

3.3 Teletype/Terminal Communications and Memory, Input/Output Selector

Communication with the Teletype/Terminal used with the system is accomplished via an Intel 8251 USART which is programmed via the 8080 to operate with 8 data bits and two stop bits in the asynchronous mode with no parity. The one of eight decoders on the printed circuit card are used to decode bits 13, 14 and 15 of the address bus to derive 8 'memory select lines' (memory select line '0' is used to enable the PROM). Input Output Select line '3' enables the Programmable Interface Card which is used to drive the Tektronix Display. The addresses for the USART are 3 FH for programming and 3 EH for data transfer.

3.4 Tektronix Display Interface

A general purpose programmable peripheral interface integrated circuit (Intel 8255) is used as an interface to the Tektronix display. This display is used in conjunction with a rotating store of 10 Kbytes which holds the information currently being displayed. When the storage memory is to be loaded the data bus is switched from recirculating mode to load mode and an external clock and data are supplied until the required data has been loaded into the memory. When the device which is loading the data relinquishes control the unit reverts to the display mode (a more complete description is given later). The P.P.I. provides three 8 bit ports which can be programmed for input or output. One of these (Port B) is configured as an output port. It is buffered with low power shottky TTL buffers and is used to transmit data to the display storage unit. A second port (Port C) is also configured as an output port and bits '0' and '1' (the least significant bits of the available output lines) are used to control the display storage unit data bus and provide the external clock. When the P.P.I. is deactivated both ports are tristated therefore the System Reset resets the display storage unit.

3.5 Remote Data Station Interface (figure 3)

The transfer of data to and from the IBM 370/168 is accomplished via a Remote Data Station. This device provides 16 input and 16 output registers each 16 bits wide and provides a signal line for each input to indicate when the register is being updated or read from. The interface to this unit consists of two 16 bit wide ports for input to and output from the 8080. These are loaded or read in a byte serial mode i.e., the 8080 reads a 16 bit word from the RDS as two 8 bit bytes. The signal lines from the RDS are used to set status latches in the RDS interface which are read by the 8080 to indicate when valid data is available or has been read.

3.6 MFE 250B Cassette Data Storage Unit Interface (figure 4)

The permanent storage medium for a digitised frame (and for some programmes) is a cassette unit constructed around an MFE 250B digital cassette transport which uses biphasic level encoding at 4800 baud to store data on cassette tapes at 10 i.p.s. To control the tape motion and transmit data to and from the tape unit a dedicated interface was built. This consists of a programmable peripheral interface which is used with one port (port A) programmed for data input (this is used to sense whether the cassette is loaded, if writing is permitted, and tape position via the leader indicator and inter record gap indicator) and port B programmed for output and buffered using CMOS buffers (this is used to reset tape motion commands, set tape direction and speed and set the 'write mode' control line during tape writing).

An 8251 USART is used to transmit data to and from the cassette unit. This is operated in the asynchronous mode with 8 data bits and no parity. The transmitter clock (4800 baud) is derived from a 9600 Hz clock in the cassette unit. The receiver clock is derived from the data being read. The transmitter empty signal from the USART is used to indicate to the cassette unit that data transmission is occurring. All signal and clock lines to and from the USART communicate with the cassette unit via RS232C line drivers and buffers.

The addresses for the tape interface are C4 for programming/reading the status of the USART and C5 for transmission of data to/from the USART. C3 is used for programming the PPI and C0 is the address for input of position/status information from the cassette unit. C1 is the address of the output port used to control the tape unit.

3.7 AGA Thermovision Interface (figure 5)

This interface is used to acquire the data from the AGA Thermovision, it consists of a crystal controlled clock generator, handshaking logic for the 8257 DMA controller, analogue input circuitry for level shifting and gain adjustment, a sample and hold amplifier and analogue to digital converter. The logic circuitry provides the signals to the 8080 to indicate that a frame of data is to be loaded. If the system interrupts are enabled the 8080 then programmes the DMA for the transfer of the first line of the frame. When the video period starts, a DMA request is made to the 8257 by the AGA interface logic. This request is held until the line period ends. The clock generator is gated by the DMA request line and generates the signals which control the sampling and conversion of the analogue data every 6.4 μ s. At the end of each conversion a 'Ready' indication is sent to the 8257 which then transfers the data to the system RAM. At the end of each line of video the DMA request is reset and an interrupt is generated. The 8080 then takes control of the bus and checks to see if the complete frame has been loaded - if it has not it reprogrammes the DMA for the next line of data to be loaded. If the frame has been loaded the DMA is disabled and will not respond to further requests for data input.

4. PERIPHERAL SUPPORT EQUIPMENT

4.1 Cassette data logger

This unit consists of a biphasic level encoder and speed control circuitry for an MFE 250B digital cassette transport. Tape motion is controlled either via a set of switches mounted on the front panel of the unit or by an external device via a set of multiplexers whose source is controlled from the front panel. RS232 line drivers and receivers are used to buffer data and clock signals to and from the biphasic level encoder. A 9600 Hz clock generates the timing signals for control of the data encoding and transmission circuitry. Clock signals at 4800 Hz are transmitted to the external device which is sending or receiving data to/from the unit to synchronise data transmission.

An external device wishing to write data on to a tape controls the motion of the tape which is set at one of three speeds (10 ips, 20 ips and 40 ips - 10 ips is used for recording and reading data). The 'write mode' control line is asserted and then the data is transmitted after the write data block line is activated (in this system this is the transmitter empty signal from the transmitting USART). The recording system does not erase tapes before data is written onto the tapes. Tapes are erased by writing with constant flux ('magnetic north') and must be erased manually using the front panel controls. The biphasic level recording mode writes at least one flux change per bit time on to the tape and the start bit of each byte is written as 'magnetic south'(ref.3). Each tape is capable of storing approximately fifteen frames of AGA data.

Data is read from the tape by reading the flux changes from the tape and locking out the half bit time flux changes. The clock signal for the receiving device is derived from the data being read.

4.2 Remote data station

This unit is supplied by Computing Services and transmits data from a remote experimental site to the IBM 370/168 via the System 7. The unit provides 16 input channels (each 16 bits wide) and 16 output channels (16 bits wide). Data is transmitted serially to/from the Central Computer Installation. The image acquisition system uses only one 16 bit channel for input of data to the Remote Data Station and one 16 bit channel for receiving data from the RDS and each 16 bit word consists of two 8 bit data bytes. The RDS provides signal lines which indicate that the RDS is reading or updating data. A 400 μ s negative going pulse is used to indicate data is being updated and a 1 μ s positive going pulse is used for indicating that data is being read.

Only one channel is used for data transmission because the mechanical and electrical complexity of interfacing an 8 bit system via 32 16 bit channels was not considered to be compensated for by any substantial increase in data transmission such transmission being primarily limited by the serial data link to the System 7.

The Remote Data Station thus provides facilities for using the processing power of the IBM 370/168 in the analysis of the data since a digitised frame can be transmitted to the 370 and retrieved for display after processing.

4.3 Tektronix display unit

Display of a stored frame is accomplished with the use of a Tektronix 604 monitor. In order to minimise interaction between the display system and the acquisition/storage system and minimise potential problems which could arise from sharing display and storage memory, the prototype acquisition system (ref.1) was modified to act as a storage unit for the Tektronix monitor. The storage unit consists of a 10 Kbyte dynamic rotating 8 bit wide memory which free runs at a clock frequency of 250 kHz. Data byte values of 'FF' and 'FE' are used to generate horizontal and vertical sync pulses. These values are not transmitted as data from the acquisition system as part of the video information. A digital to analogue converter is used to generate the video signal from the stored data and horizontal and vertical deflection generators (controlled by the exclusive synchronising codes FF and FE) control the trace positioning.

Before transmission the C.P.U. checks the video data and if it has the value 'FE' or 'FF' it truncates this to 'FC'. At the end of each line of video data transmitted the C.P.U. inserts the necessary code ('FF') for horizontal synchronisation.

Data is loaded by applying a logical '1' on the recirculate/load multiplexer which routes data from the external data bus input into the memory. When the data has been stable on the data bus input for 100 μ s a clock pulse is generated by applying a logical '1' to the external clock input line. Data must be clocked in at a minimum 100 Hz rate (the guaranteed minimum for the memory integrated circuits used). Synchronising data is loaded as required (the frame format is changed simply by rearranging the relative positions of the synchronising signals in the data stream). When the data has been completely loaded control is relinquished by applying a logical '0' to the external load controller (the relevant control pins of the data multiplexer) and the display free runs at 250 kHz (25 frames/s).

The display unit is provided with an isotherm display. This is provided in digital and analogue form. The digital isotherm compares the data presented on a set of thumbwheel switches with the data presented to the D/A converter, and if the data are equal the video is driven to peak white. The analogue isotherm is adjustable in amplitude and width and is operated from the front panel. A line selector is provided to allow the user to view via a C.R.O. the video waveform of any selected line.

5. SOFTWARE DESCRIPTION

The operation of the data acquisition system is controlled by a program stored in the Programmable Read Only Memories (PROMs). The operating system currently occupies approximately 4 Kbytes of memory and provides some diagnostic aids as well as controlling system operation. The software listing is not illustrated here (it is too long for the purposes of this report) but the operational principles are illustrated via the simplified flowchart for frame acquisition and display in figure 6.

All user commands are accessed by typing the relevant command character (e.g., 'E' to enable acquisition of a frame) followed by a carriage return. The operating system then searches a command table to determine whether the input was a valid command and if not it prompts the user with an asterisk ('*') and awaits a new input. If the command was valid the system prompts the user for any relevant data which may be required for execution of the command.

The valid commands available under the system are illustrated in Table 1 with a brief description of their functions. The tape handling facilities provide for the storage/retrieval of two types of records from tape these being video information from the AGA (which is stored in fixed format) and any other data (which may for example be a program and may be stored anywhere in the available random access memory).

Both types of data are read with the same command ('R') but the system prompts the user to determine which type of data (e.g., AGA video or program) is being read. When an AGA file is read the time and date of the original recording, and the sensitivity setting of the AGA are displayed on completion of the reading of the tape. When recording an AGA file the command 'S' is used and the system prompts the user for the time, date and sensitivity data which can be entered in free format. To record free format data 'W' is used and the system prompts for the memory locations to be stored on tape.

Recording of the data is done at 4800 Baud and the 'Intel' record format is used. For each record of 16 bytes this stores the address at which the data is to be stored and a longitudinal checksum for verification of the data. The tape handling software operates only on absolute addresses and the data cannot be relocated during the reading process. If during the reading process the longitudinal checksum fails the user is informed at the end of the reading of the tape if there are less than eight errors. The addresses at which the errors occurred are also displayed. If more than eight errors are logged the reading is terminated. If at any stage the system is unable to find the start of two consecutive records reading is also terminated.

Uncommitted random access memory has been provided for the development and debugging of signal processing algorithms which may be loaded via the cassette tape facilities.

6. APPLICATIONS

The use of the system for the analysis of data obtained using the AGA Thermovision has been discussed before. The system will allow the determination of radiometric data from the video signal and allow the presentation of this data in forms which were not before feasible (e.g., three dimensional or two dimensional contour plotting of intensity distributions), and will allow faster processing of this data.

The development of signal processing algorithms and display formats will be aided by the availability of a programmable processing and display system. A contrast enhancement algorithm has been developed to operate on AGA data and edge enhancement and one and two dimensional filter algorithms will be developed. The ability to acquire large amounts of data in an easily processed form will also facilitate the study of the statistics of the video signals being processed with the possibility of the development of optimal filters and target recognition algorithms.

The contrast enhancement algorithm is based on a contrast enhancement scheme proposed by L. Sevingny(ref.4). The contrast enhancement is achieved by replacing the data from any picture element or pixel (whose value is designated by g_i) with

$\max(0, \min(Ng - 1, [(Ng - 1)/2] + K(g_i - \bar{g}))$ or if \bar{g} differs significantly from $\frac{Ng}{2}$

$\max(0, \min(Ng - 1, \bar{g} + K(g_i - \bar{g}))$.

where Ng is the number of quantisation levels carrying the information

K is the amplification factor

and \bar{g} is the average data value obtained by summing the data over the frame.

Figure 7 illustrates this schematically and illustrates the flowchart used in the algorithm. The current version of the algorithm uses the maximum data value in the frame for the value of Ng and uses for K , multipliers which are expressed as $n/8$ (where n is an integer). This allows the effect of a range of multipliers to be examined by merely adjusting the integer n in the software. The processed frame is then displayed using the Tektronix display facilities. Figure 8 illustrates the effect of contrast enhancement on a frame for differing values of n .

7. CONCLUSION

The implementation of a microprocessor based image acquisition system has provided enhanced data processing and analysis facilities for infrared imagery. The acquisition system has been designed so that data can be transferred to and from the DRCS Central Computer to facilitate the application of sophisticated processing to the data.

A contrast enhancement algorithm has been implemented using the display facilities and available memory of the system and will be used in conjunction with the development of further signal processing algorithms in studies of the application of Infrared Imaging systems and their applications and the presentation of data obtained using these systems to the observer. With some modification and perhaps further expansion the system could be applied to the evaluation of imaging systems.

8. ACKNOWLEDGEMENTS

The author wishes to express his appreciation for the aid received in construction of this equipment. He is most grateful to Dr D.J. Heilbronn for his comments and suggestions in the development of the software.

REFERENCES

No.	Author	Title
1	Poropat, G.V.	"A Data Acquisition System for the Analysis of Infrared Imagery Obtained Using the AGA Thermovision". WRE-TM-1735 (A), July 1977
2	Poropat, G.V.	"Determination of the Optimum Sampling Rate and Filter Parameters for Digital Processing of a Line Scanned Imaging System". WRE-TM-1559 (AP), May 1976
3	-	Operation and Interface Manual for MRE250B Digital Cassette Tape Transport.
4	Sevingny, L.	"Le Traitement des Images et L'Acquisition d'Objectif Dans l'Infrarouge". DREV Report 4050/76, April 1976

TABLE 1. SYSTEM COMMANDS AND FUNCTIONS

Diagnostic Commands

- D - Display
User Inputs the Required Memory Addresses and the Contents of the Memory are displayed on the terminal.
- I - Insert Data Into Memory
User Inputs Address at which to begin and valid hexadecimal data is then inserted into memory locations specified.
- C - Change Memory Data
Allows the user to examine (and modify) memory contents byte by byte.
- G - Go To
Allows the user to execute a program by specifying the start address required.

Tape Handling Commands

- R - Read a File from Tape
Allows the user to read a program or video file from a cassette tape.
- W - Write a File onto Tape
Allows the user to store data from the memory on the cassette tape by specifying the memory range to be stored.
- S - Save a Frame of Video on Tape
Allows the user to store a full frame from the AGA on cassette tape.
- V - Verify a File on Tape
Checks that the File specified can be read from the tape.
- P - Position a Tape
Allows the user to position a tape at the I.R.G. at the start of a file (which can then be erased).

Data Acquisition and Storage Commands

- E - Primes the system to digitise and store video frame.

Frame Display

- T - Displays the Stored Frame on the Tektronix Monitor.

R.D.S. Transfer Commands

- A - Receives a Frame of Data from the IBM 370/168 via the R.D.S.
- B - Transmits a Stored Frame to the IBM 370/168 via the R.D.S.

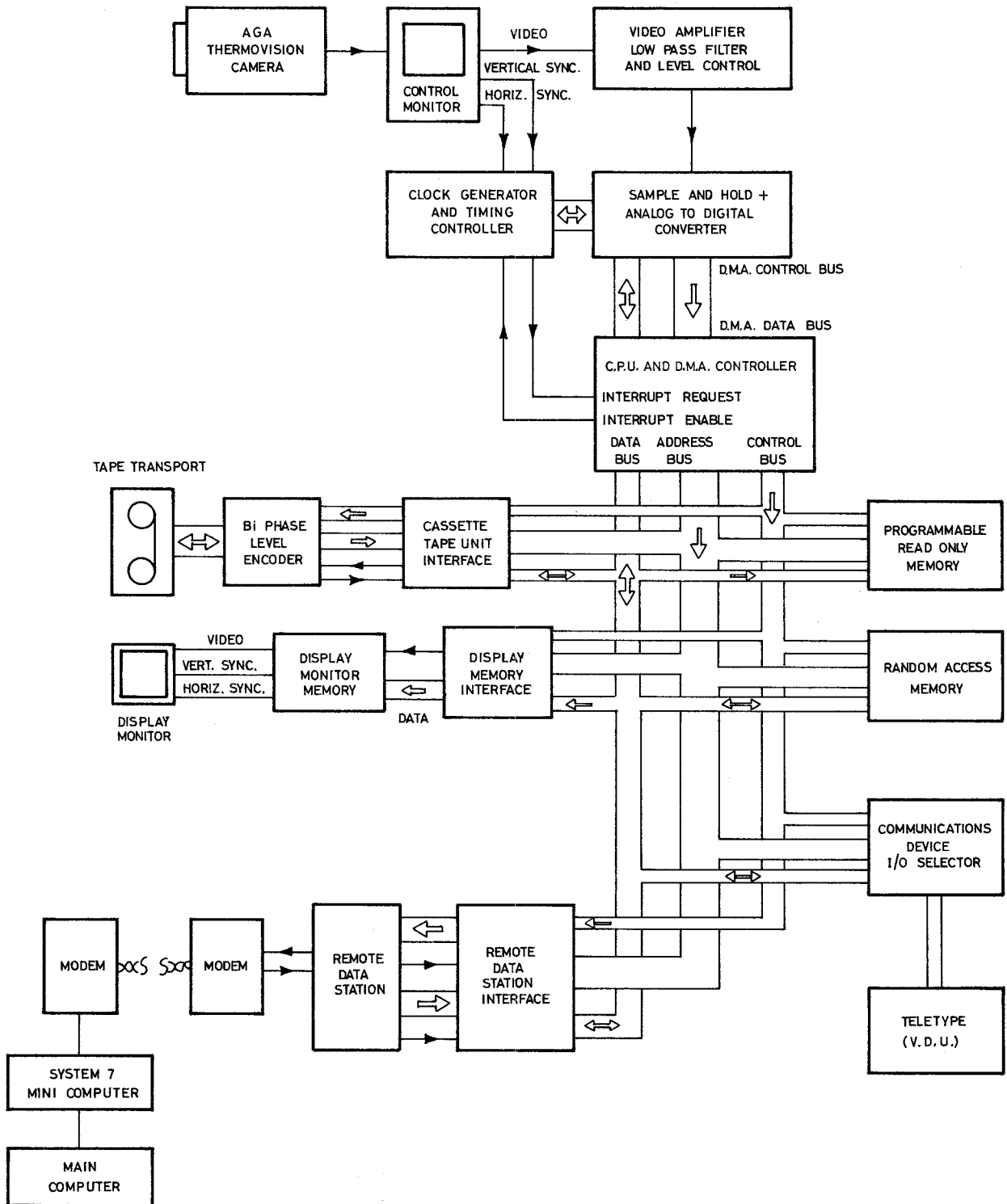
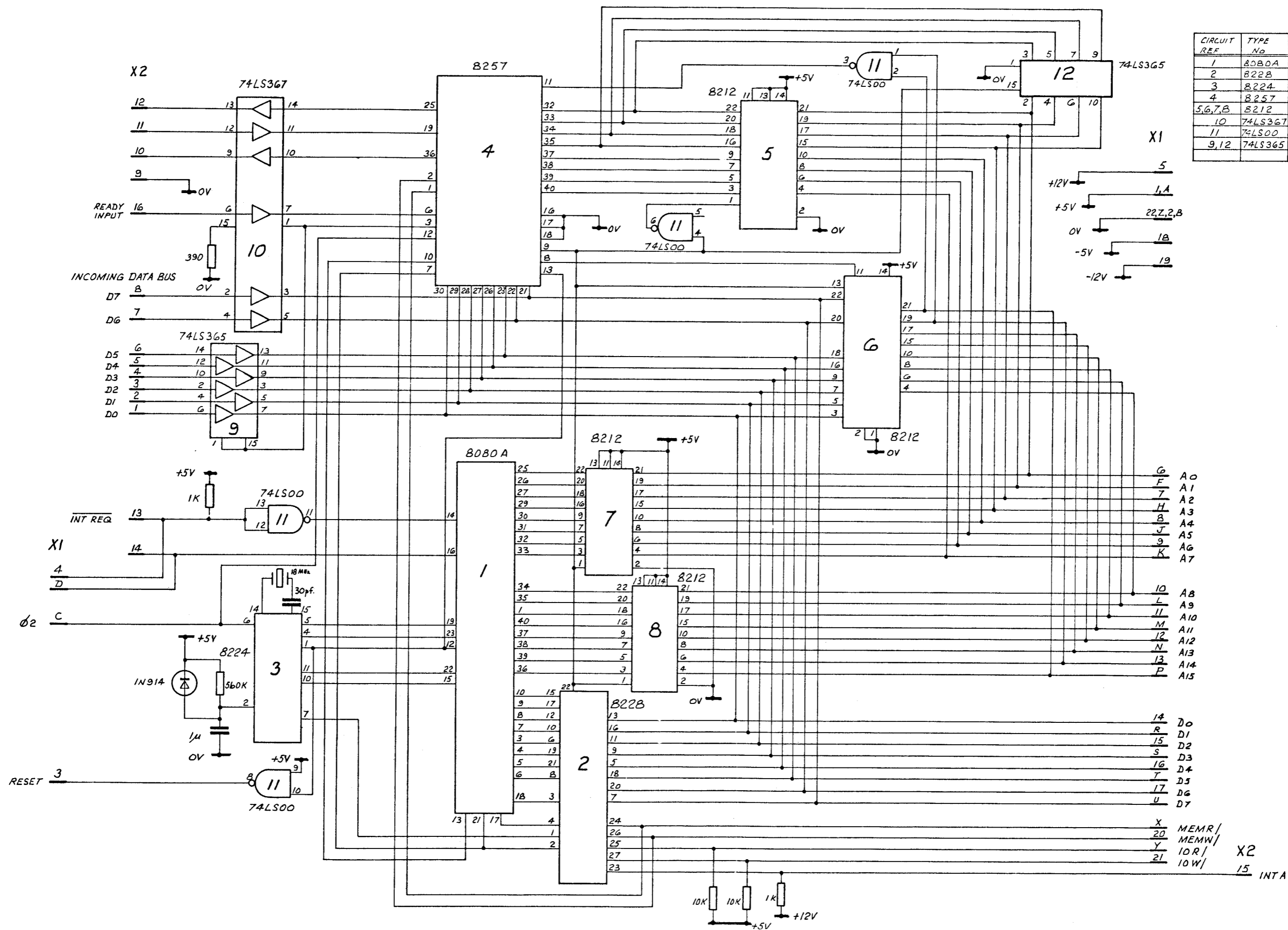

Figure 1. Functional layout of the data acquisition system



CIRCUIT REF	TYPE No	+12V	+5V	0V	-5V	-12V
1	8080A	28	20	2	11	-
2	8228	-	28	14	-	-
3	8224	9	16	8	-	-
4	8257	-	-	-	-	-
5,6,7,8	8212	-	24	12	-	-
10	74LS367	-	16	8	-	-
11	74LS00	-	14	7	-	-
9,12	74LS365	-	16	8	-	-

Figure 2. Circuit diagram of the CPU/DMA Controller Board

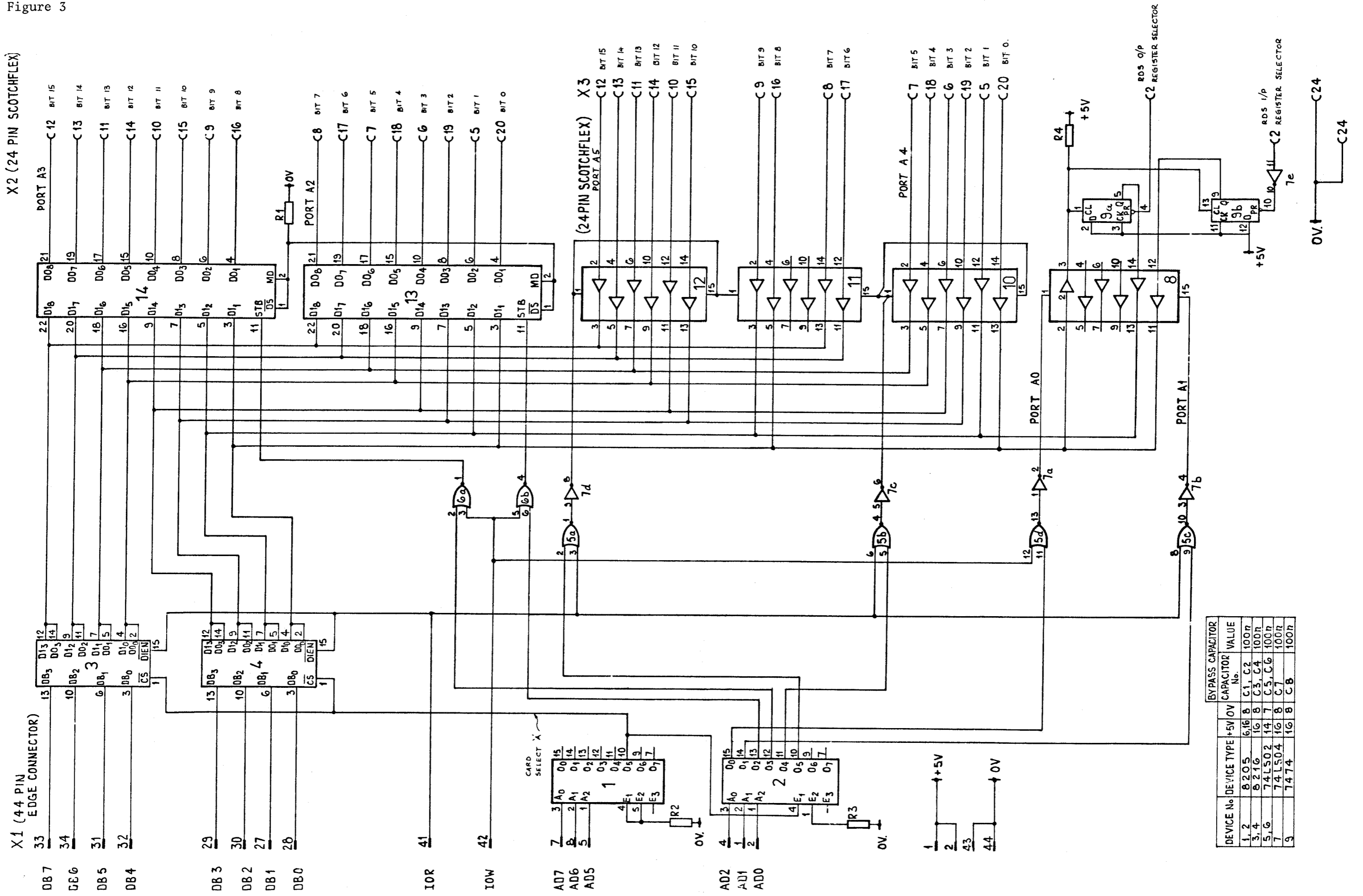

Figure 3. Circuit diagram of the Remote Data Station Interface

MODE DEFINITION 090
8255 PORT A I/P
PORT B O/P

NOTE
REF IC 11
CONNECT PINS 2,12,13 TO +5v
" " 3,6,11 TO 0v

CCT. REF.	TYPE	+5v PIN	0v PIN	+12v	-12v
1	I 8255	26	7		
2	CD 4050	1	8		
3	I 8251	26	4		
4,5	I 8216	16	8		
6,7	I 8205	16	8		
8	74LS04	14	7		
10	μA 9017	14	7		
11	μA 9016	7	14		
12	7490	5	10		
13	DM 8093	14	7		
9					

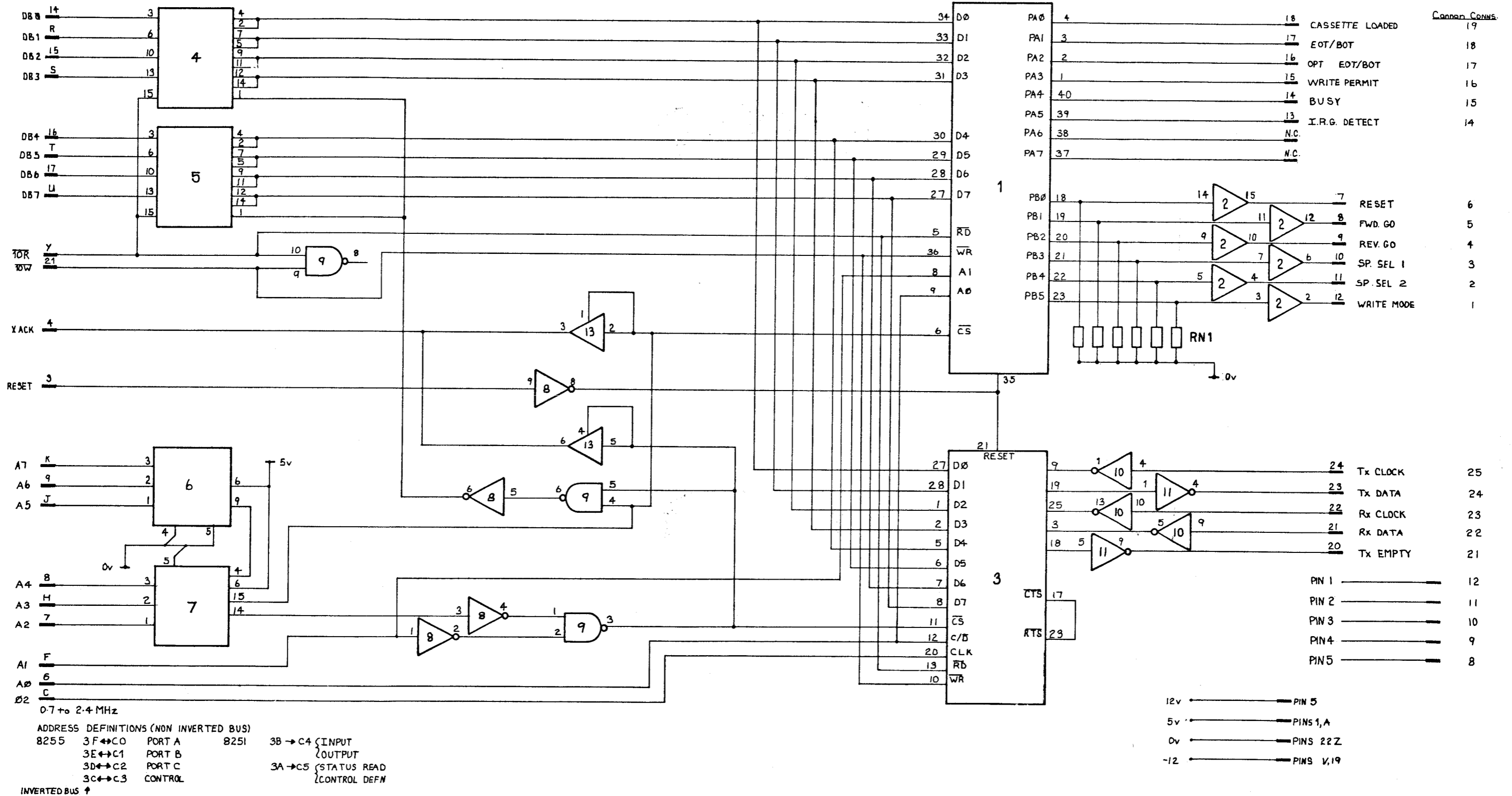

Figure 4. Circuit diagram of the Cassette Tape Storage Unit Interface

POWER SUPPLY CONNECTIONS
EDGE CONNECTOR

ANALOG GND.	41, 42. (21, Y.)
DITIGAL GND.	43, 44. (22, Z.)
+15V	11, 12. (6, F.)
-15V	39, 40. (20, X.)
+5V	1, 2. (1, A.)

EDGE CONNECTOR NOS ARE FOR WIRE WRAPPED SOCKETS
& ARE NUMBERED 1-44.

THE EQUIVALENT PINS FOR CANNON SERIES OF
CONNECTORS ARE :-

PIN 1	PIN A.
PIN 2	PIN 1
PIN 3	PIN 3
PIN 4	PIN 2.

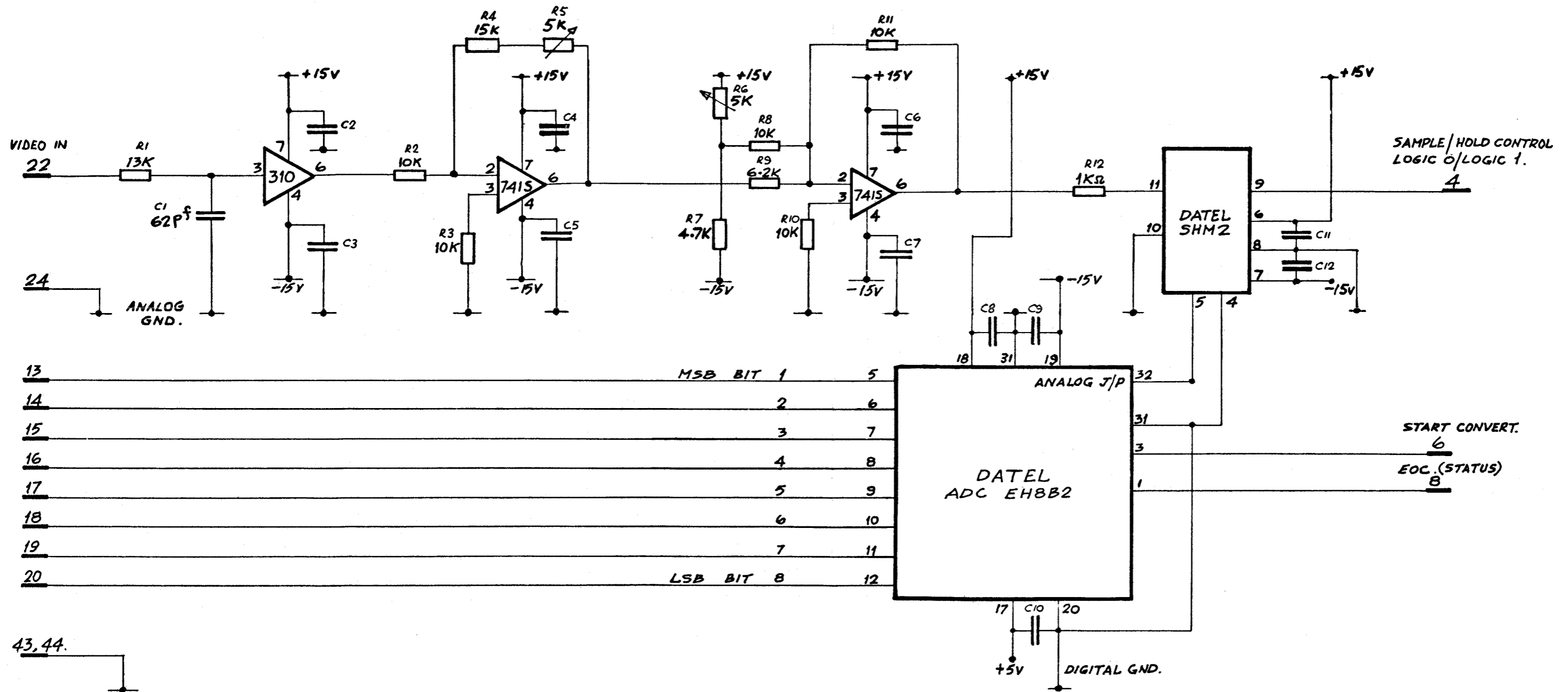

Figure 5(a). Video amplifier and analogue to digital converter for the AGA thermovision interface

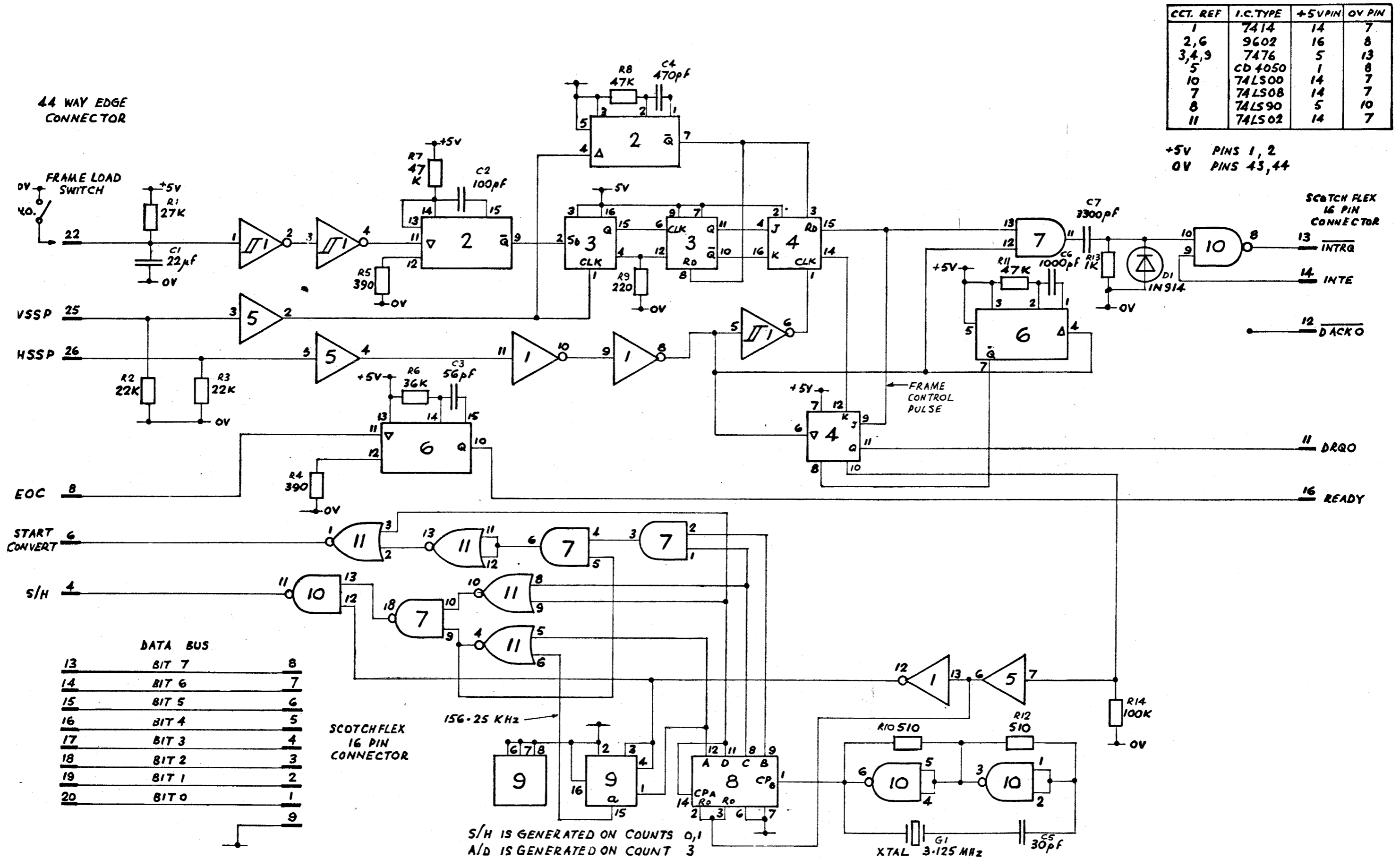
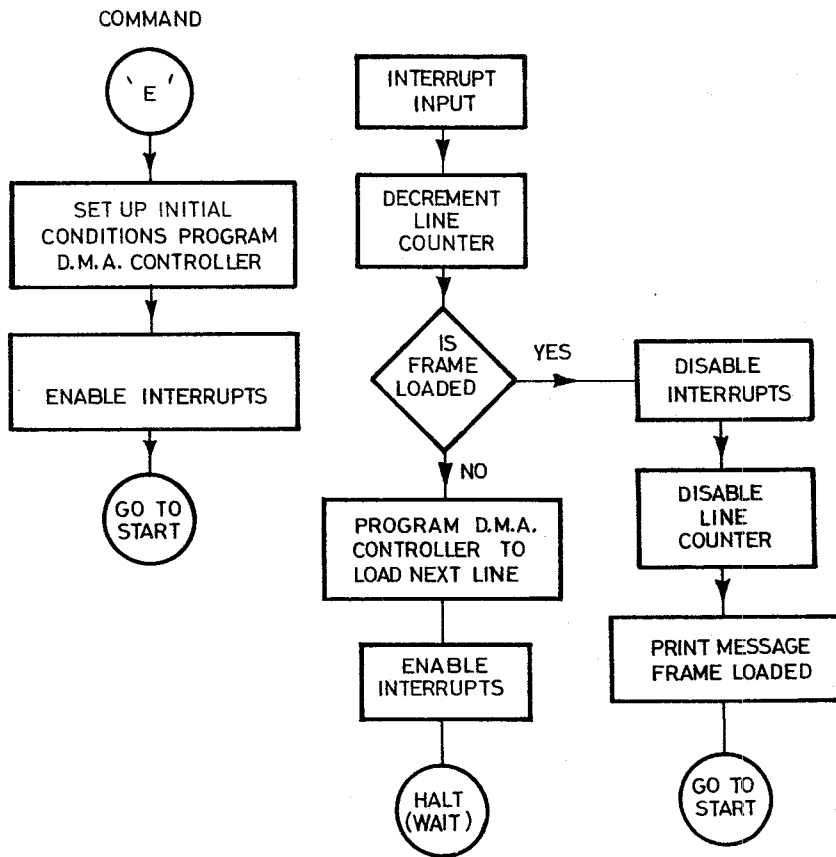
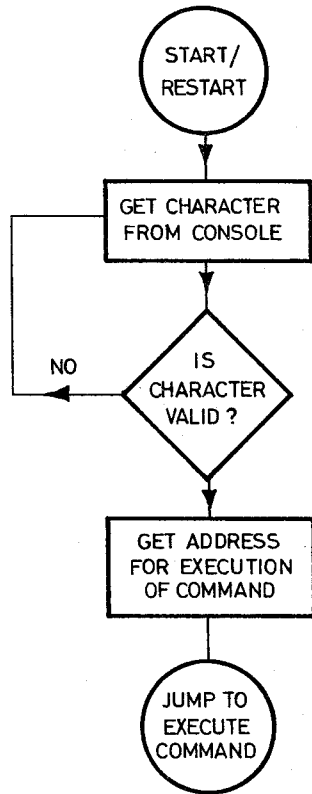
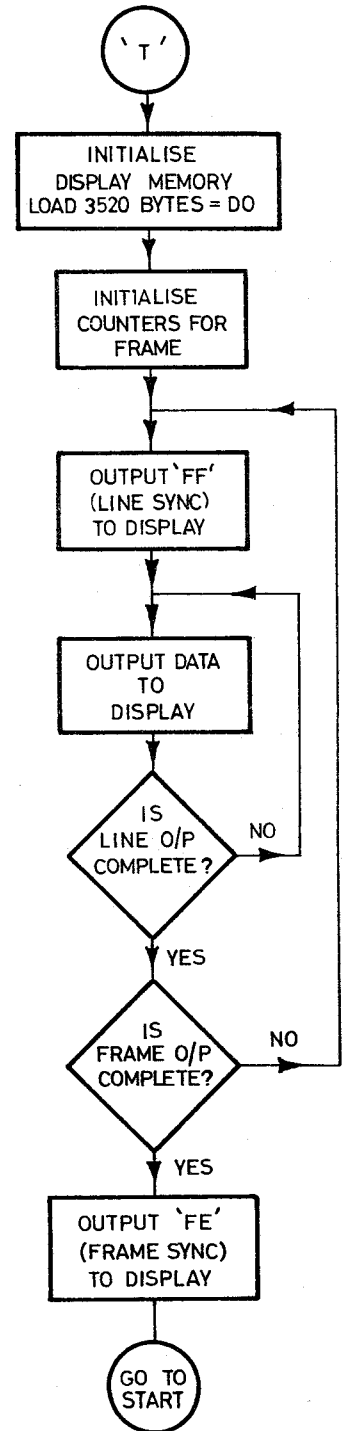

Figure 5(b). Timing controller for AGA thermovision interface

(a) Command input flowchart



(b) Flowchart for command to enable acquisition of a frame and to load frame via an interrupt service routine



(c) Flowchart to display stored frame via Tektronix monitor

Figure 6. Simplified flowchart of command input, frame acquisition and display

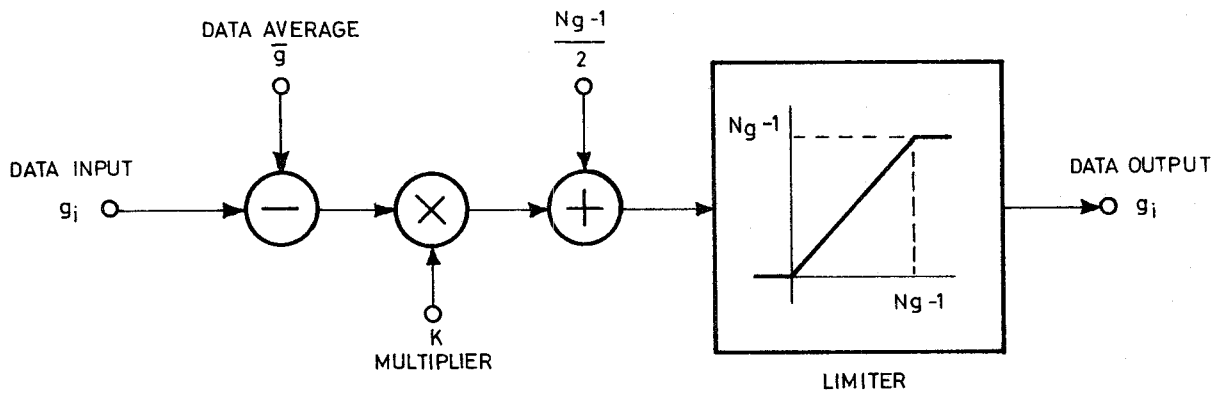

Figure 7(a). Algorithm for video contrast enhancement

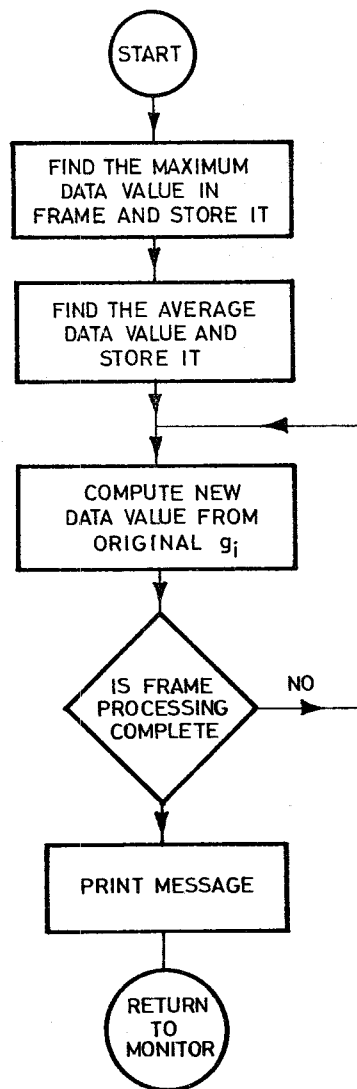

Figure 7(b). Flowchart for implementation of the algorithm



(a) Unprocessed frame



(b) Enhanced contrast (n=12)



(c) Enhanced contrast (n=16)

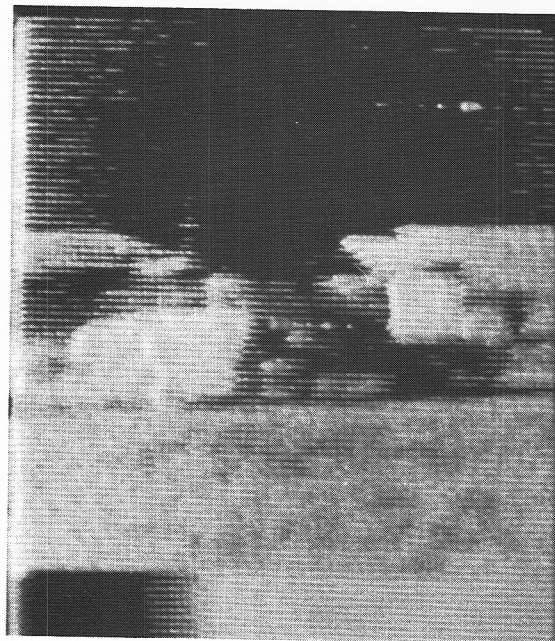

(d) enhanced contrast (n=24)

Figure 8. Effect of contrast enhancement for various values of multiplier (n)

DOCUMENT CONTROL DATA SHEET

Security classification of this page

UNCLASSIFIED

1	DOCUMENT NUMBERS
AR Number: AR-001-425	
Report Number: ERL-0050-TM	
Other Numbers:	

2	SECURITY CLASSIFICATION
a. Complete Document: Unclassified	
b. Title in Isolation: Unclassified	
c. Summary in Isolation: Unclassified	

3	TITLE
A MICROPROCESSOR BASED IMAGE STORAGE AND ANALYSIS FACILITY FOR INFRARED SIGNATURE MEASUREMENT AND IMAGE PROCESSING	

4	PERSONAL AUTHOR(S):
G.V. Poropat	

5	DOCUMENT DATE:
November 1978	

6	6.1 TOTAL NUMBER OF PAGES	23
	6.2 NUMBER OF REFERENCES:	4

7	7.1 CORPORATE AUTHOR(S):
Electronics Research Laboratory	
	7.2 DOCUMENT SERIES AND NUMBER
Electronics Research Laboratory -0050-TM	

8	REFERENCE NUMBERS
a. Task: DST 76/014	
b. Sponsoring Agency:	

9	COST CODE:
308772	

10	IMPRINT (Publishing organisation)
Defence Research Centre Salisbury	

11	COMPUTER PROGRAM(S) (Title(s) and language(s))

12	RELEASE LIMITATIONS (of the document):								
Approved for Public Release									
12.0	OVERSEAS	NO	P.R.	1	A	B	C	D	E

Security classification of this page:

UNCLASSIFIED

13 ANNOUNCEMENT LIMITATIONS (of the information on these pages):

No Limitation

<p>14 DESCRIPTORS:</p> <p>a. EJC Thesaurus Terms</p>	<p>Infrared equipment Infrared detectors Infrared detection Image converters Data acquisition Data reduction</p> <p>Display devices</p>	<p>15 COSATI CODES:</p> <p>1705 0901</p>
<p>b. Non-Thesaurus Terms</p>	<p>Image storage Image processing Infrared imagery Microprocessor control</p> <p>Microprocessors</p>	

16 LIBRARY LOCATION CODES (for libraries listed in the distribution):

SW SR SD AACA

17 SUMMARY OR ABSTRACT:
 (if this is security classified, the announcement of this report will be similarly classified)

The design and operation of a microprocessor based data acquisition system is described. The system is capable of digitising and storing a frame of pictorial information from an AGA Thermovision and provides facilities for the analysis of the stored information. Transfer of the stored information to the IBM 370/168 can be achieved at high speed and sophisticated processing applied to the stored data. The use of a microprocessor as the controlling unit has allowed the implementation of some analysis and processing facilities at the experimental site.