

AD-A065 875

FOREIGN TECHNOLOGY DIV WRIGHT-PATTERSON AFB OHIO  
UNIFIED CHANNEL FOR CONTROLLING EXPERIMENT IN PROCESS OF GATHER--ETC(U)  
NOV 77 A G KOLESNIKOV, V M ZAIKIN

F/6 5/2

UNCLASSIFIED

ETD-TD/PC/T-1882-77

NL

1 OF 1  
A D A  
065875



END  
DATE  
FILMED  
4-79  
DDC

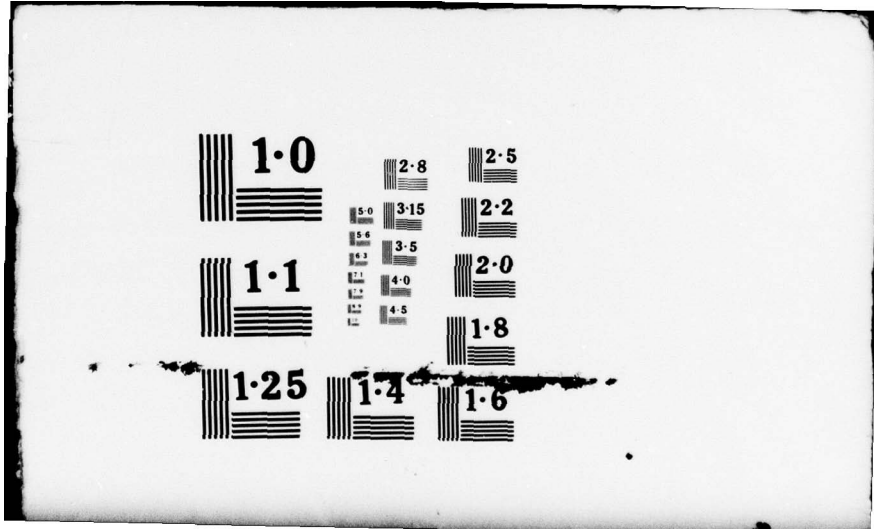



AD-A065875

# FOREIGN TECHNOLOGY DIVISION



UNIFIED CHANNEL FOR CONTROLLING EXPERIMENT IN  
PROCESS OF GATHERING AND PROCESSING OCEANOGRAPHIC  
INFORMATION

by

A. G. Kolesnikov, V. M.  
Zaikin

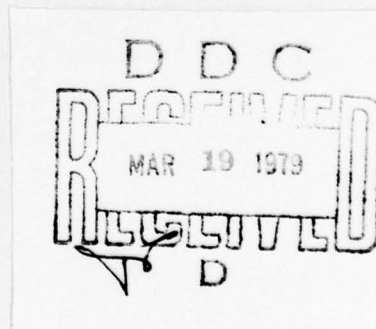

Approved for public release;  
distribution unlimited.

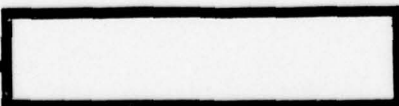

ACCESSION IN	White Section <input checked="" type="checkbox"/>
WTB	Buff Section <input type="checkbox"/>
UNANNOUNCED	<input type="checkbox"/>
JUSTIFICATION	
BY:	
DISTRIBUTION/CLASSIFICATION CODES	
Date	CLASSIFICATION
<b>A</b>	

**EDITED TRANSLATION**

FTD-ID(RS)T-1882-77                      16 November 1977

MICROFICHE NR: *FTD-77-C-001427*

UNIFIED CHANNEL FOR CONTROLLING EXPERIMENT IN  
PROCESS OF GATHERING AND PROCESSING OCEANOGRAPHIC  
INFORMATION

By: A. G. Kolesnikov, V. M. Zaikin

English pages: 13

Source: Morskiye Gidrofizicheskiye Issledovaniya,  
Sevastopol', No. 4(63), 1973, pp. 84-91.

Country of origin: USSR  
Translated by: Marilyn Olachea  
Requester: DET 3/FTD/DO  
Approved for public release; distribution  
unlimited.

<p><b>THIS TRANSLATION IS A RENDITION OF THE ORIGINAL FOREIGN TEXT WITHOUT ANY ANALYTICAL OR EDITORIAL COMMENT. STATEMENTS OR THEORIES ADVOCATED OR IMPLIED ARE THOSE OF THE SOURCE AND DO NOT NECESSARILY REFLECT THE POSITION OR OPINION OF THE FOREIGN TECHNOLOGY DIVISION.</b></p>	<p><b>PREPARED BY:</b>  <b>TRANSLATION DIVISION FOREIGN TECHNOLOGY DIVISION WP-AFB, OHIO.</b></p>
--	---

U. S. BOARD ON GEOGRAPHIC NAMES TRANSLITERATION SYSTEM

Block	Italic	Transliteration	Block	Italic	Transliteration
А а	<b>А а</b>	A, a	Р р	<b>Р р</b>	R, r
Б б	<b>Б б</b>	B, b	С с	<b>С с</b>	S, s
В в	<b>В в</b>	V, v	Т т	<b>Т т</b>	T, t
Г г	<b>Г г</b>	G, g	У у	<b>У у</b>	U, u
Д д	<b>Д д</b>	D, d	Ф ф	<b>Ф ф</b>	F, f
Е е	<b>Е е</b>	Ye, ye; E, e*	Х х	<b>Х х</b>	Kh, kh
Ж ж	<b>Ж ж</b>	Zh, zh	Ц ц	<b>Ц ц</b>	Ts, ts
З э	<b>З э</b>	Z, z	Ч ч	<b>Ч ч</b>	Ch, ch
И и	<b>И и</b>	I, i	Ш ш	<b>Ш ш</b>	Sh, sh
Й й	<b>Й й</b>	Y, y	Щ щ	<b>Щ щ</b>	Shch, shch
К к	<b>К к</b>	K, k	Ъ ъ	<b>Ъ ъ</b>	"
Л л	<b>Л л</b>	L, l	Ы ы	<b>Ы ы</b>	Y, y
М м	<b>М м</b>	M, m	Ь ь	<b>Ь ь</b>	'
Н н	<b>Н н</b>	N, n	Э э	<b>Э э</b>	E, e
О о	<b>О о</b>	O, o	Ю ю	<b>Ю ю</b>	Yu, yu
П п	<b>П п</b>	P, p	Я я	<b>Я я</b>	Ya, ya

\*ye initially, after vowels, and after ь, ы; e elsewhere.  
When written as ë in Russian, transliterate as yë or ë.

RUSSIAN AND ENGLISH TRIGONOMETRIC FUNCTIONS

Russian	English	Russian	English	Russian	English
sin	sin	sh	sinh	arc sh	sinh <sup>-1</sup>
cos	cos	ch	cosh	arc ch	cosh <sup>-1</sup>
tg	tan	th	tanh	arc th	tanh <sup>-1</sup>
ctg	cot	cth	coth	arc cth	coth <sup>-1</sup>
sec	sec	sch	sech	arc sch	sech <sup>-1</sup>
cosec	csc	csch	csch	arc csch	csch <sup>-1</sup>

Russian      English

rot      curl  
lg      log

UNIFIED CHANNEL FOR CONTROLLING EXPERIMENT IN PROCESS OF GATHERING  
AND PROCESSING OCEANOGRAPHIC INFORMATION

A. G. Kolesnikov, V. M. Zaikin

ABSTRACT        Described in this article is a developed subsystem for remote information exchange with arbitrary addressing of coded messages which employs the unified channel principle. The subsystem is a component in an automated system for gathering, transmitting, and processing oceanographic information on a scientific research vessel and serves the purpose of optimizing marine research. END  
ABSTRACT



One of the most pressing problems of modern oceanography is that of optimizing marine research. The development of methods for optimal control of experiments in the process of studies conducted by scientific research vessels is particularly significant. The object of the controlled experiment is to achieve a certain goal, which is expressed in terms of the criteria of control quality. It presumes a sliding estimation of the parameters of the studied process and assming and carrying out solutions at each stage of observation, which can only be justified on a sufficient level of automation in obtaining and processing oceanographic information. Study of the existing information base reveals that automated equipment for gathering and processing information onboard scientific research vessels does not completely solve the problem of optimizing experiments [1]. Here we can cite several individual examples where control over observations took place [2, 3]. The main reason for insufficient use of optimal research methods in conducting expedition studies is the lag in development of the means of communications between subsystems for processing and gathering information. The problem lies not only in the creation of specialized input-output equipment, but also in the organization of an effective exchange process, which, in the final analysis, will make control of experiments feasible.

A subsystem for remote data exchange with arbitrary addressing

of coded messages between subscriber points of scientific research vessels has been developed at the Marine Geophysical Institute of the AS UkSSR. The subsystem is part of an automated system for gathering, transmitting, and processing oceanographic information, and it links the computer center, laboratories, information services, and ship complexes into a single communications circuit [2].

The principle of a unified (trunk) channel is used for organizing the exchange. It is described as follows. Different sources and users of the address and digital information are switched to a common data transmission trunk. The switching is done by means of identical (standard) devices, which serve as intermediaries between the channel and the user. An asynchronous communications cycle is used in the channel. This is begun at an arbitrary moment in time by interrogation from a unit. Within the course of the cycle the channel is made available to only one unit and only one message is transmitted. It is made available by the "channel dispatcher" - a device which reacts to interrogation and which plans the work of the channel. The transmission rate of data in the trunk line should be high enough to assure a channel division mode between many users. The channel is called programmed if a small electronic computer is used as the dispatcher. The structure of the trunk channel is distinguished by its high efficiency and flexible coupling, can be easily expanded, and enjoys the most recognition at the present time.



The principle of the trunk channel has been achieved in one form or another in certain new computer systems designed for processing and control in a real time scale (RTS) [4, 5].

The unified channel variation which we examine here was designed as an intermediary between a base electronic computer and the information complexes of the computer system of a scientific research vessel during simultaneous experiment processing and control. The channel is formed from a network of terminal devices, which are called standard subscriber consoles, communications lines, and a central dispatcher device. The structural system of the channel is shown in the figure.

Standard subscriber panel (A11-2 in figure) is the main element of the system and consists of a high-speed input-output dispatcher. The panel has input and output registers, and thus also performs the functions of individual subscriber storage. The subscriber panels connect different types of sources and information requesters with the trunk line. These are installed at the places where measuring and control equipment is concentrated (usually in ship laboratories) and are switched to the outputs of the general information trunk line, for which a wide-band differential line is used.

During input the panel performs the following operations:

asynchronous reception of subscriber information in the form of series or parallel binary code, reduction of data to a single format for the entire system - information bit with formation of address and code of operation, establishing information communication with channel dispatcher, transmission (input) of one bit of address-numerical information to channel when permission signal is received from dispatcher.

During output of the data from the channel the following occurs: expansion of address code in transmitted information bit; output from channel of numerical information and operation code under the condition that the expanded address coincides with the one adapted to the given panel; expansion of operation code containing tag of user for whom the information is intended for command for control of working mode of panel; establishing information communication with user according to indicated tag (operation), or carrying out command; transmission of numerical data to user.

The work algorithm of the panel and its technical data are described as follows.

1. Control of transfer of panel to active mode (mode in which it is possible to establish communication with dispatcher) and vice versa - manual and automatic programmed.

2. Control of address assembly - manual and automatic.

3. Control of change in working mode of panel - manual for two checking modes, manual and automatic for third and fourth working modes. Third mode - interrogation of dispatcher on readiness of message. Fourth - programmed input with control from computer.

4. Information inputs - universal: series or parallel binary code, positive or negative polarity of input signals. Possibility of manual assembly of arbitrary message in input register.

5. Dimension of information bit - 44 binary bits. Of them 37 fall within numerical information, which conforms to the bit configuration of the base computer ("Minsk-22"), 4 bits to the address and 3 for indicating the operation code.

6. Maximal transmission rate (input-output) is  $0.5 \times 10^6$  bytes/s.

7. Method of data modulation - pulse-code modulation. The numbers "1" and "0" are represented by videopulses which are strobed and conducted along the two channels.

The information trunk line is a group line, and virtually any number of input-output devices can be connected to its outputs along its entire length. Data is transmitted in an arbitrary direction according to an indicated address at a rate of  $0.5 \times 10^6$  bytes/s, which corresponds to a throughput capacity of about 10 thousand 44-bit words/s. The line is formed from two wide-band cables for separate transmission of "0" and "1." The figure shows the method of connecting the transmitting and receiving assemblies with the line. The outputs of the linear transmitters of the subscriber panels form together with the line the logic operator "conductive OR." The high input resistance of the linear receivers has virtually no effect on the distributed line impedance. As a result of this a fairly large number of devices can be switched simultaneously to the line. Compatible active loads, whose nominal corresponds to the wave resistance of the cable, are switched to the free ends of the line. This almost completely eliminates reflection in the line and gives the transmitted signal an undistorted shape. The noise resistance of the transmission is assured by the method of modulation, the independence of transmission from the physical length of the line and reaction time of the receiving-transmitting devices due to the absence of the problem of synchronization, the use of a line with low-resistance compatible loads and careful working out of circuitry



problems with respect to eliminating false states of functional units.

In addition to the information line, low-frequency supply lines are used, along which service signals are sent when communication is established and the channel is shared. All that is required are two lines which are common to the entire system, along which "output" and "state of the channel" signals are sent, and two individual lines for each panel, along which "dispatcher interrogation" and "input" signals are transmitted.

Channel dispatcher (DK). The structure of this device must be developed in keeping with the development of the methods of using the channel. A modern, highly effective minicomputer with developed systems of commands, priority interrupts, input-output, and storage, is being proposed as a prospective dispatcher. The developed variation meets only minimal requirements for automatic channel sharing among terminal devices upon interrogation from these devices in a priority discipline order and planning of the allocation moment of the channel. The channel is allocated for transmission of only one quantum of information, after which it again becomes available for the planning organ of the dispatcher. In agreement with the number of addresses (there are four binary bits for address information), the dispatcher has 16 inputs and the same number of outputs. The



individual lines of the terminal devices are switched to them. The inputs receive "dispatcher interrogation" signals, while "input" signals which permit transmission are formed in the appropriate outputs. Simultaneously with any of the "input" signals a general "output" signal is formed, which brings the address registers of all terminals back to their original state. The planning organ - priority circuit with additional control inputs - is switched between the inputs and the outputs. One of the inputs receives information on the state of the channel (free - busy). Others can be used for control from the computer, time sensor (timer), channel load meter, etc. While the priority circuit determines which of the anticipated inquiries should be serviced first, the control inputs are used for planning the moment of service allocation. In addition to the planning organ, the central device contains the main blocks of the standard subscriber panel, which also enable the dispatcher to perform the input-output and memory element functions.

#### Conclusion

1. The developed variation of the unified channel can be easily connected to already existing facilities for gathering and processing oceanographic information. Although the dimension of the information quantum is selected in accordance with the bit configuration of the

computer "Minsk-22," it can be easily altered if a different type of computer is used as the base. The asynchronous method of transmitting information assures adaptation to lines with any parameters or length. This makes it possible to use this channel in all scientific research vessels equipped with information gathering and processing equipment.

2. The unified channel assures the necessary intensive exchange of information between the center which processes data and the experimental control complexes of the scientific research vessels during control of geophysical experiments. However, in this case the base computer must work in a time-sharing mode. The partial interrupts in the main programs associated with this may lead to a significant reduction in the time allocated for calculation and, consequently, to a loss in the efficiency of using the computer. An effective solution to the problem would be to control the channel by using a modern minicomputer with a sufficient storage volume and a developed periphery. In this case the main computer is freed from work in the time-sharing mode and is used to solve problems which require a great volume of calculations. The channel itself becomes the basis for the multiprocessor computation-control system of the scientific research vessel, in which the minicomputer, in addition to controlling the channel, also functions as the preprocessor for the main computer.

3. Use of the unified channel in systems which gather and process hydrophysical information creates the prerequisites for developing methods of controlling observations. An important advantage in these methods lies in the fact that they consider the specific statistical structure and space-time changeability of the studied ocean fields. Using this channel the following can be achieved:

a) Input and processing in real time scale of data on studied process, obtained from several measuring devices, generally of a different scale. This method makes it possible to greatly reduce the level of distortion, expand the range of measured frequencies, distinguish classes of random processes, and achieve solutions at each step of observation, depending on the changeability of the process.

b) Input and processing in real time scale of information from synchronous observations of different physical processes. The method makes it possible to present the general dynamic structure of the physical fields of the ocean in a studied region and to plan the experiment operationally.

c) Adaptive changes. The above method presumes that the computer device has a controlling influence on the algorithm or trajectory of the measuring device. The data base for rapid analysis of statistical process parameters is controlled. An example of this is the experiment discussed in [3] with adaptive adjustment of the measurement algorithm to the structure of the studied field, which was done using the described methods and was provided by a special control program.

Operational planning of the experiment can be based on all of the methods mentioned above: selecting the type of experiment, making decisions on stopping or continuing observation, selecting a point (station) at which to make the next observation.

#### BIBLIOGRAPHY

1. Современная аппаратура для океанографических исследований. (Обзор. Под ред. академика АН УССР А.Г. Колесникова.) Севастополь, изд. МГИ АН УССР, 1970.
2. Колесников А.Г. Автоматизация океанографических исследований. - "Океанология", 1971, 11, № 5.
3. Колесников А.Г. и др. Адаптивные измерения гидрофизических элементов с использованием ЭЦВМ. - В кн.: "Морские гидрофизические исследования", № 2(58). Севастополь, изд. МГИ АН УССР, 1972.
4. Виноградов В.И. Современное развитие программно-управляемых модульных структур для автоматизации измерений и управления экспериментом. - "Автометрия", 1972, № 4.
5. Чертков, Кейди. Мини-ЭЦВМ с унифицированным каналом. - "Электроника", 1970, № 26.



Figure. Structure of unified channel circuit. ДК - channel dispatcher; АП - subscriber panel; ЭВМ - electronic computer. KEY: (1) Information trunk, (2) Supply lines.

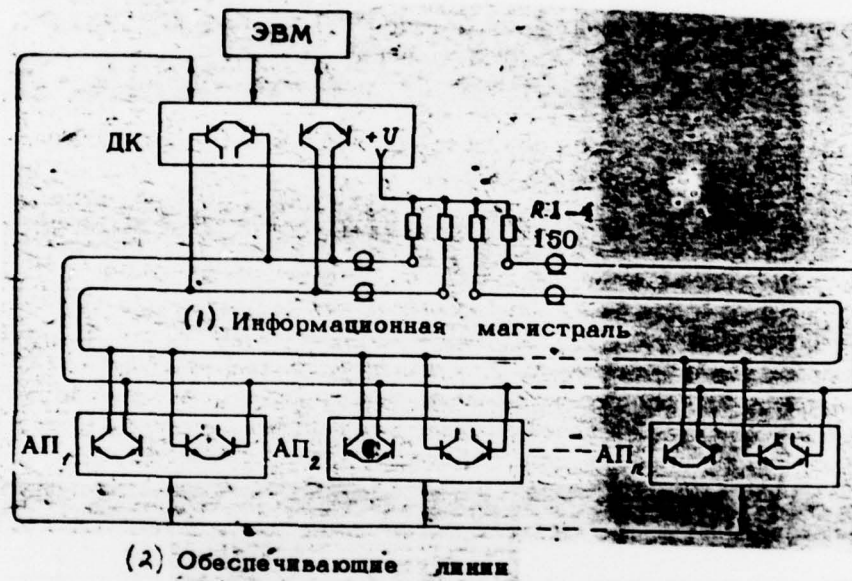



DISTRIBUTION LIST

DISTRIBUTION DIRECT TO RECIPIENT

ORGANIZATION	MICROFICHE	ORGANIZATION	MICROFICHE
A205 DMATC	1	E053 AF/INAKA	1
A210 DMAAC	2	E017 AF/RDXTR-W	1
B344 DIA/RDS-3C	8	E404 AEDC	1
C043 USAMIIA	1	E408 AFWL	1
C509 BALLISTIC RES LABS	1	E410 ADTC	1
C510 AIR MOBILITY R&D LAB/FIO	1	E413 ESD	2
C513 PICATINNY ARSENAL	1	FTD	
C535 AVIATION SYS COMD	1	CCN	1
	1	ETID	3
C591 FSTC	5	NIA/PHS	1
C619 MIA REDSTONE	1	NICD	5
D008 NISC	1		
H300 USAICE (USAREUR)	1		
P005 ERDA	1		
P055 CIA/CRS/ADD/SD	1		
NAVORDSTA (50L)	1		
NASA/KSI	1		
AFIT/LD	1		