

AD-A065 809

DAVID W TAYLOR NAVAL SHIP RESEARCH AND DEVELOPMENT CE--ETC F/G 20/3
THE MAGNETIC INDUCTION OF THE SYSTEM CONSISTING OF A COIL AND A--ETC(U)
MAR 79 S H BROWN, F E BAKER

UNCLASSIFIED

DTNSRDC/PAS-78-35

NL

1 OF 2
AD A065809



LEVEL II

12
NW

**DAVID W. TAYLOR NAVAL SHIP
RESEARCH AND DEVELOPMENT CENTER**

Bethesda, Maryland 20084



DTNSRDC/PAS-78-35

THE MAGNETIC INDUCTION OF THE SYSTEM CONSISTING OF A COIL AND
A FERROMAGNETIC SPHERICAL BODY

AD A0 65809

DDC FILE COPY

THE MAGNETIC INDUCTION OF THE SYSTEM CONSISTING
OF A COIL AND A FERROMAGNETIC
SPHERICAL BODY

By
Samuel H. Brown and F. Edward Baker, Jr.

DDC
MAR 15 1979

APPROVED FOR PUBLIC RELEASE: DISTRIBUTION UNLIMITED

PROPULSION AND AUXILIARY SYSTEMS DEPARTMENT
RESEARCH AND DEVELOPMENT REPORT

March 1979

DTNSRDC/PAS-78-35

79 03 14 021

MAJOR DTNSRDC ORGANIZATIONAL COMPONENTS

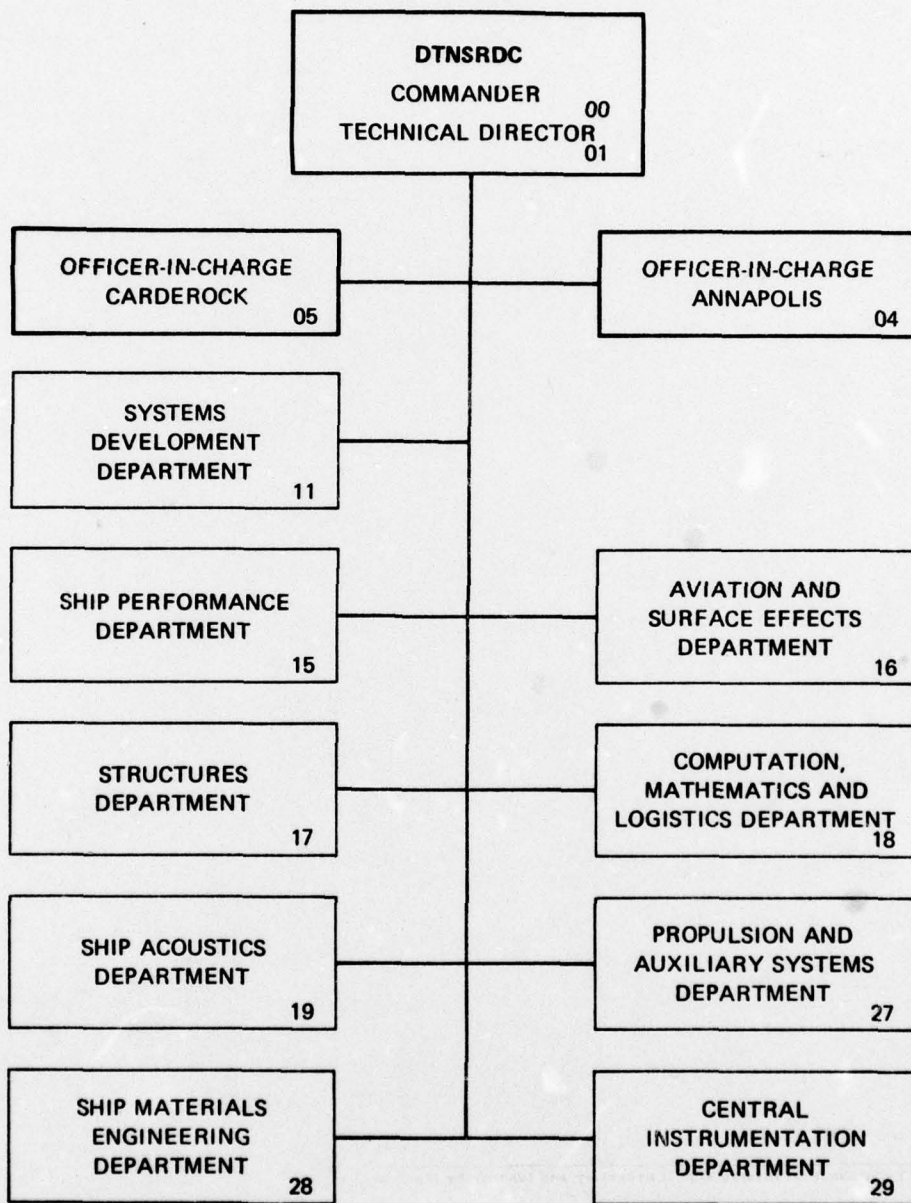

UNCLASSIFIED

SECURITY CLASSIFICATION OF THIS PAGE (When Data Entered)

REPORT DOCUMENTATION PAGE		READ INSTRUCTIONS BEFORE COMPLETING FORM
1. REPORT NUMBER DTNSRDC/PAS-78-35	2. ACCESSION NO. Research and development report	3. RECIPIENT'S CATALOG NUMBER
4. TITLE (and Subtitle) THE MAGNETIC INDUCTION OF THE SYSTEM CONSISTING OF A COIL AND A FERROMAGNETIC SPHERICAL BODY	5. TYPE OF REPORT & PERIOD COVERED	
7. AUTHOR(s) Samuel H. Brown and F. Edward Baker, Jr	6. PERFORMING ORG. REPORT NUMBER	
9. PERFORMING ORGANIZATION NAME AND ADDRESS David W. Taylor Naval Ship R&D Center Annapolis, MD 21402	10. PROGRAM ELEMENT, PROJECT, TASK AREA & WORK UNIT NUMBERS PE 11221N, TA B0005-SL001 Work Unit 2704-110	
11. CONTROLLING OFFICE NAME AND ADDRESS David W. Taylor Naval Ship R&D Center Annapolis, MD 21402	12. REPORT DATE March 1979	13. NUMBER OF PAGES 66
14. MONITORING AGENCY NAME & ADDRESS (if different from Controlling Office) 41 p.	15. SECURITY CLASS. (of this report) UNCLASSIFIED	
15a. DECLASSIFICATION/DOWNGRADING SCHEDULE		
16. DISTRIBUTION STATEMENT (of this Report) APPROVED FOR PUBLIC RELEASE: DISTRIBUTION UNLIMITED.		
17. DISTRIBUTION STATEMENT (of the abstract entered in Block 20, if different from Report)		
18. SUPPLEMENTARY NOTES		
19. KEY WORDS (Continue on reverse side if necessary and identify by block number) Electromagnetic fields Magnetic induction Induction Ferromagnetism		
20. ABSTRACT (Continue on reverse side if necessary and identify by block number) The magnetic induction is calculated for two configurations of a ferromagnetic spherical body surrounded by a current-carrying conductor. The first case is for an infinitesimally thin current band carrying a stationary current and surrounding a spherical shell. The second case is for a current band of finite width carrying a stationary current and surrounding a solid sphere. The ferromagnetic bodies are assumed to be linear and (see other side)		

DDC
RECEIVED
MAR 15 1979
C

DD FORM 1473 1 JAN 73

EDITION OF 1 NOV 65 IS OBSOLETE
S/N 0102-LF-014-6601

UNCLASSIFIED

SECURITY CLASSIFICATION OF THIS PAGE (When Data Entered)

408 615

UNCLASSIFIED

SECURITY CLASSIFICATION OF THIS PAGE (When Data Entered)

Item 20 (Cont)

homogeneous. The reduction of the solution for the dipole term to that of a filamentary circular current-carrying conductor is shown in the first case when the permeability of the ferromagnetic spherical shell is allowed to approach that of free space.

UNCLASSIFIED

SECURITY CLASSIFICATION OF THIS PAGE (When Data Entered)

TABLE OF CONTENTS

	Page
LIST OF FIGURES	iv
LIST OF ABBREVIATIONS	v
EXECUTIVE SUMMARY	ix
ABSTRACT	1
ADMINISTRATIVE INFORMATION	1
INTRODUCTION	1
BASIC EQUATIONS	2
THIN COIL SURROUNDING A FERROMAGNETIC SPHERICAL SHELL	6
GENERAL SOLUTION	6
BOUNDARY CONDITIONS	13
EXPANSION OF THE CURRENT ($J_\psi(\theta)$) IN ASSOCIATED LEGENDRE POLYNOMIALS	18
FERROMAGNETIC SPHERE SURROUNDED BY A COIL OF FINITE WIDTH	21
GENERAL SOLUTION	21
BOUNDARY CONDITIONS	24
CONCLUSIONS AND RECOMMENDATIONS	27
ACKNOWLEDGMENT	27
APPENDIX A - CALCULATION OF COEFFICIENTS OF THE VECTOR POTENTIALS FOR A THIN COIL SURROUNDING A FERROMAGNETIC SPHERICAL SHELL	29
APPENDIX B - DETERMINATION OF POTENTIALS FOR INFINITESIMALLY THIN CURRENT BAND AND INFINITESIMALLY THIN COIL	35
APPENDIX C - REDUCTION OF THE MAGNETIC VECTOR POTENTIAL FOR A THIN COIL SURROUNDING A FERROMAGNETIC SPHERICAL SHELL TO THAT OF A THIN COIL IN FREE SPACE WHEN IN THE LIMIT μ_1 EQUALS μ_2	41
APPENDIX D - SOLUTION OF THE AZIMUTHAL COMPONENT OF THE VECTOR POISSON'S EQUATION $\nabla^2 A_\psi = -\mu J_\psi$ IN SPHERICAL COORDINATES	51
APPENDIX E - CALCULATION OF COEFFICIENTS OF THE VECTOR POTENTIAL FOR A SOLID FERROMAGNETIC SPHERE SURROUNDED BY A COIL OF FINITE WIDTH	57
REFERENCES	63

ACCESSION for	Write Section <input checked="" type="checkbox"/>	Buff Section <input type="checkbox"/>	DISTRIBUTION OF REPLY COPIES	OFFICIAL
	DDC <input type="checkbox"/>	UNANNOUNCED JUSTIFICATION <input type="checkbox"/>		
A				

LIST OF FIGURES

	Page
1. Typical Magnetization	4
2. Ferromagnetic Spherical Shell Surrounded by an Infinitesimally Thin Current Band	7
3. Spherical Coordinate System and the Corresponding Unit Vectors	8
4. Spherical Coil Cross-Sectional View - Definition of Angle Alpha	20
5. Coil Current as a Function of the Polar Angle Theta	21
6. Ferromagnetic Sphere Surrounded by a Coil of Finite Width (yz Plane)	22

LIST OF ABBREVIATIONS

\vec{A}	Vector potential function
A_ψ	Azimuthal (ψ) component of \vec{A}
$A_{\psi I}$	Azimuthal component of \vec{A} in region I
$A_{\psi II}$	Azimuthal component of \vec{A} in region II
$A_{\psi III}$	Azimuthal component of \vec{A} in region III
$A_{\psi IV}$	Azimuthal component of \vec{A} in region IV
\vec{B}	Magnetic flux density or magnetic induction
B_1	Magnetic flux density in medium I
B_2	Magnetic flux density in medium II
B_r	Radial component of the magnetic flux density
B_θ	Theta component of the magnetic flux density
B_{rI}	Radial component of \vec{B} in region I
B_{rII}	Radial component of \vec{B} in region II
B_{rIII}	Radial component of \vec{B} in region III
B_{rIV}	Radial component of \vec{B} in region IV
B_{n1}	Normal component of \vec{B} in medium 1
B_{n2}	Normal component of \vec{B} in medium 2
\vec{H}	Magnetic field intensity
H_1	Magnetic field intensity in medium 1
H_2	Magnetic field intensity in medium 2
H_{t1}	Tangential component of \vec{H} in medium 1
H_{t2}	Tangential component of \vec{H} in medium 2
\vec{J}	Electric current density
J_r	Radial component of \vec{J}
J_θ	Theta component of \vec{J}
J_ψ	Azimuthal component of \vec{J}

\vec{J}_s	Surface current density
I	Electric current
χ_m	Magnetic susceptibility
μ	Magnetic permeability
μ_r	Relative magnetic permeability
μ_0	Permeability of free space
μ_1	Permeability
μ_2	Permeability
\vec{n}_{12}	Unit vector normal to interface; directed from medium 1 into medium 2
x, y, z	Rectangular coordinates
r, θ, ψ	Spherical coordinates
\vec{e}_r	Unit normal vector in radial direction
\vec{e}_θ	Unit normal vector in theta direction
\vec{e}_ψ	Unit normal vector in azimuthal direction
$\vec{\nabla} \cdot$	Divergence operator
$\vec{\nabla} \times$	Curl operator
∇^2	Scalar Laplacian operator
∇^2	Vector Laplacian operator
p	Integer from one to infinity
dv	Elemental volume
r	Radius of spherical coordinate system
r'	Distance of the point where \vec{A} is being determined from
$P_p^m(\cos\theta)$	Associated Legendre function of the first kind
$Q_p^m(\cos\theta)$	Associated Legendre function of the second kind
c	Speed of light in vacuum

\vec{A}_ψ

Azimuthal component of the vector Laplacian of \vec{A} in spherical coordinates

$(\vec{\nabla} \times \vec{A})_r$

Radial component of the curl of \vec{A}

$(\vec{\nabla} \times \vec{A})_\theta$

Theta component of the curl of \vec{A}

R_i ($i=1,2,3$)

Component of radius vector to boundary i which has spherical symmetry (see Figures 2 and 6)

θ_1, θ_2

Polar angles describing the limits of the current band

A_{pi} , ($i = 1,2,3$), B_{pi} , ($i = 2,3,4$) The constant in the r part of the solution for the azimuthal component of the vector potential \vec{A} in region i

$$\left(A_{\psi i} = \sum_{p=1}^{\infty} \left[A_{pi} r^p + B_{pi} / r^{(p+1)} \right] P_p^1(\cos\theta) \right. \\ \left. \text{see equation (28).} \right)$$

A'_p, B'_p, C_p, D_p

The constants in the general solution to the r and θ parts of A_ψ [$A_\psi = R(r) \Theta(\theta)$ where $R(r) =$

$$\sum_{p=1}^{\infty} A'_p r^p + B'_p / r^{(p+1)} \text{ and } \Theta(\theta) = \sum_{p=1}^{\infty} C_p P_p^1(\cos\theta)$$

$$+ D_p Q_p^1(\cos\theta), \text{ see equation (25)}]$$

A_p, B_p

The constants in the general solution to the r part of

$$A_\psi \left[A_p = \sum_{p=1}^{\infty} \left(A_p r^p + \frac{B_p}{r^{(p+1)}} \right) P_p^1(\cos\theta), \right.$$

see equation (27)]. Also, $A_p = A'_p C_p$ and $B_p = B'_p C_p$
see (equation 27).

EXECUTIVE SUMMARY

THE MAGNETIC INDUCTION OF THE SYSTEM CONSISTING OF A COIL AND A FERROMAGNETIC SPHERICAL BODY

OBJECTIVE

The objective of this work was to derive solutions to static ferromagnetic problems that included both current-carrying coils and linear ferromagnetic bodies. The solutions are intended for comparison with solutions to ferromagnetic problems obtained by various numerical techniques such as the finite difference method, the finite element method, and the integral equation iterative solution method.

APPROACH

After deriving the governing differential equation from Maxwell's equations for classical magnetostatic field theory, the method of separation of variables was employed to obtain the problem solution.

RESULTS

The magnetic induction was calculated for two geometries (configurations) of a ferromagnetic spherical body surrounded by a current-carrying conductor. The first case was for an infinitesimally thin current band carrying a stationary current and surrounding a spherical shell. The second case was for a current band of finite width carrying a stationary current and surrounding a solid sphere. The ferromagnetic bodies were assumed to be linear and homogeneous. The reduction of the solution of the dipole term to that of a filamentary, circular, current-carrying conductor is shown for the first case when the permeability of the ferromagnetic spherical shell is allowed to approach that of free space.

RECOMMENDATIONS

It is recommended that the derived solutions be programmed on a digital computer for direct comparison of these results to those obtained by various numerical methods. There are plans to implement these recommendations during the fiscal years 1979 and 1980.



ABSTRACT

The magnetic induction is calculated for two configurations of a ferromagnetic spherical body surrounded by a current-carrying conductor. The first case is for an infinitesimally thin current band carrying a stationary current and surrounding a spherical shell. The second case is for a current band of finite width carrying a stationary current and surrounding a solid sphere. The ferromagnetic bodies are assumed to be linear and homogeneous. The reduction of the solution for the dipole term to that of a filamentary circular current-carrying conductor is shown in the first case when the permeability of the ferromagnetic spherical shell is allowed to approach that of free space.

ADMINISTRATIVE INFORMATION

This work was performed under Program Element 1121N, Project B0005, Task Area B0005-SL-001, Work Unit 2704-110. The project director is Mr. J. L. Corder, David W. Taylor Naval Ship Research and Development Center.

INTRODUCTION

In the past, exact analytical solutions of Maxwell's equations using classical formulations have been limited to body shapes and inhomogeneities that conform to a few separable coordinate systems. With the advent of modern digital computers with large computational and storage capabilities, many electromagnetic field problems of importance in engineering practice can and have been solved by using a numerical solution to the governing differential or integral equations under a suitable choice of boundary conditions. Such numerical solutions of Maxwell's equations, when used with a complete description of the electric and magnetic sources and the constitutive laws of the media, can be used to describe completely the electric and magnetic fields produced by the source, including nonsymmetric geometries, nonsymmetric source distributions, and spatially varying media parameters.

The literature¹⁻⁶ contains numerous examples that demonstrate the power of using numerical techniques such as the finite difference method, the finite element method, and the integral equation iterative solution method. Both two- and three-dimensional electrical engineering problems have been solved. Authors have tried to validate the numerical methods and calculations by comparing numerical results to:

1. Simple problems using engineering approximations.
2. Other numerical method solutions of the same problem.
3. Laboratory experimental results.
4. Problems that have analytical solutions.

Another technique that could be used but which the authors of this report have not seen very widely used in the literature is a comparison of two theoretical formulations for a given problem solved by the same numerical method. An example might be a vector potential formulation compared to a scalar potential formulation.

The motivation for this work arose out of the need for solutions to static ferromagnetic problems that could be used for comparison with numerical methods. The capability exists to calculate the magnetic field due to a ferromagnetic body immersed in a constant inducing field for the following bodies: solid sphere, spherical shell, solid prolate spheroid, prolate spheroidal shell, solid general ellipsoid, and general ellipsoidal shell.⁷ Also, the capability exists to calculate the magnetic field caused by a single or combination of current-carrying coils.⁸ However, the capability did not exist to calculate the magnetic field caused by a ferromagnetic body in the presence of the field created by a current-carrying coil.

BASIC EQUATIONS

We can start with Maxwell's equations for classical magnetostatic field problems

¹A complete listing of references appears on page 63.

$$\vec{\nabla} \times \vec{H} = \vec{J} \quad (1a)^*$$

$$\vec{\nabla} \cdot \vec{B} = 0 \quad (1b)$$

where \vec{H} magnetic field intensity (A/m)**
 \vec{B} magnetic flux density (T or Wb/m²)
 \vec{J} electric current density (A/m²)

In the general case for ferromagnetic materials \vec{B} is a nonlinear function of \vec{H}

$$\vec{B} = f(\vec{H}) \quad (2)$$

where as shown in Figure 1a \vec{B} is not a single valued function of \vec{H} . The function $f(\vec{H})$ depends on the magnetic history of the material, that is how the metal attained its magnetization. This is referred to as hysteresis. It is also noted that any property of a ferromagnetic material has meaning only if it is considered together with its complete magnetic history.

In certain practical engineering problems, the variation in the magnetic intensity is small, and the functional relationship between \vec{B} and \vec{H} is approximately linear (see Figure 1b). For the linear case where the material is isotropic, the magnetic induction \vec{B} is related to the field intensity \vec{H} by the relationship

$$\vec{B} = \mu_0 (\chi_m + 1) \vec{H} = \mu_0 \mu_r \vec{H} = \mu \vec{H} \quad (3)$$

where χ_m magnetic susceptibility (dimensionless)
 μ magnetic permeability (henry/meter)
 $(\chi_m + 1) = \mu_r$ relative permeability (dimensionless)
 μ_0 free space permeability ($4\pi \times 10^{-7}$ henry/meter)

*The del operator $\vec{\nabla}$ is defined with respect to the rectangular coordinate system and is strictly valid in a rectangular coordinate system only. Very often $\vec{\nabla} \times$ and $\vec{\nabla} \cdot$ are used as equivalent symbols for curl and divergence generally. This use is followed in this report.

**Definitions of abbreviations are on page v.

(a) Curve for a Ferromagnetic Material

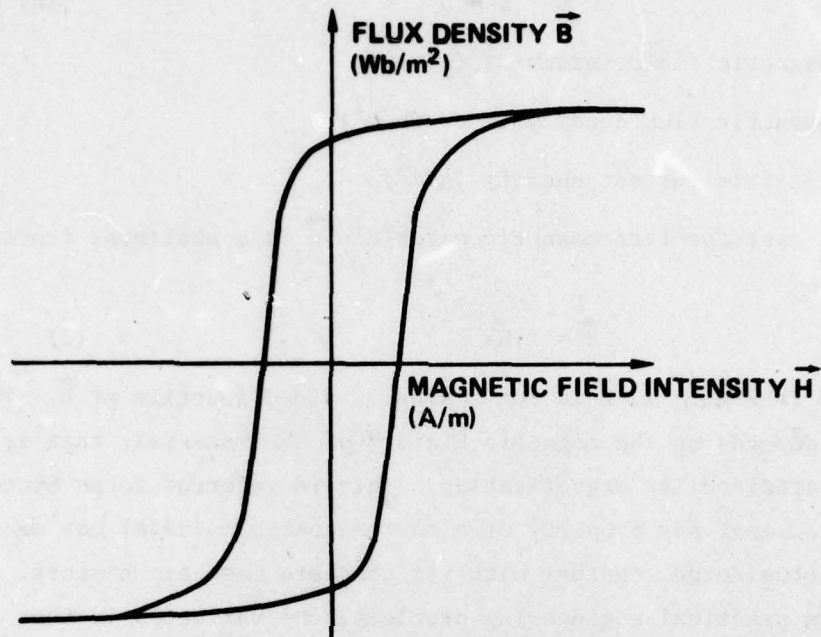

(b) Curve for a Ferromagnetic Material at Low Inducing Fields

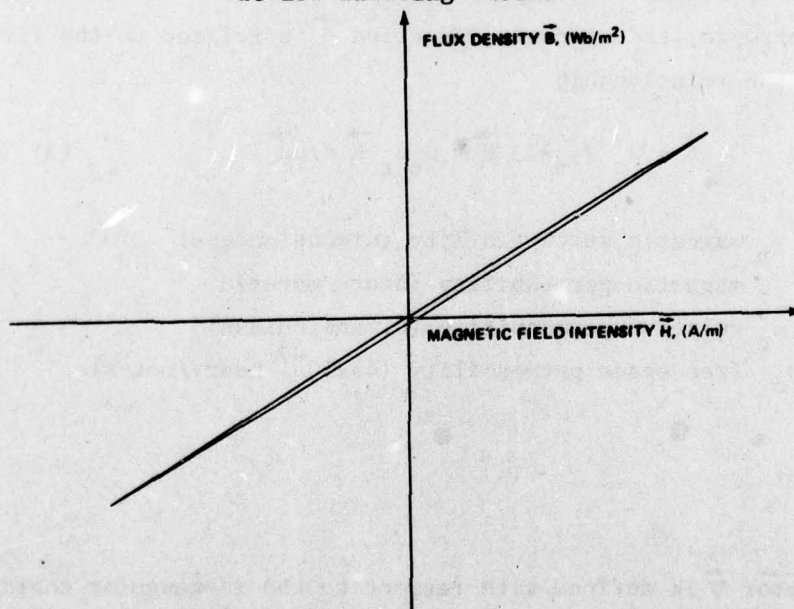

Figure 1 - Typical Magnetization

This report assumes that the ferromagnetic body has isotropic and linear material properties. The divergenceless nature of the magnetic flux density in conjunction with the fact that the divergence of the curl of any vector function is zero allows the introduction of the magnetic vector potential field (\vec{A})

$$\vec{B} = \nabla \times \vec{A} \quad (4)$$

where \vec{A} is the magnetostatic vector potential function in weber/meter. The substitution of equation (4) into equation (1a) gives the fundamental equation of the vector potential of the magnetostatic field.

$$\frac{1}{\mu} \nabla \times (\nabla \times \vec{A}) - (\nabla \times \vec{A}) \times \nabla \frac{1}{\mu} = \vec{J} \quad (5)$$

For homogeneous materials as assumed in this report the magnetic permeability is spatially invariant. Hence

$$\nabla \frac{1}{\mu} = 0 \quad (6)$$

and equation (5) reduces to

$$\nabla \times \nabla \times \vec{A} = \mu \vec{J} \quad (7)$$

Using the vector identity

$$\nabla \times \nabla \times \vec{A} = \nabla (\nabla \cdot \vec{A}) - \nabla^2 \vec{A} \quad (8)$$

equation (7) becomes

$$\nabla (\nabla \cdot \vec{A}) - \nabla^2 \vec{A} = \mu \vec{J} \quad (9)$$

The magnetostatic vector potential is characterized by the important property that its divergence can be conveniently chosen to be zero.

$$\nabla \cdot \vec{A} = 0 \quad (10)$$

Equation (9) reduces to the vector Poisson's differential equation.

$$\nabla^2 \vec{A} = -\mu \vec{J} \quad (11)$$

This is the governing equation for our calculations.

The general boundary conditions to be satisfied at the interfaces of stationary dissimilar media may be derived from the limiting integral forms of Maxwell's equations and are given by

$$\vec{n}_{12} \cdot (\vec{B}_2 - \vec{B}_1) = 0 \text{ or } B_{n1} = B_{n2} \quad (12a)$$

$$\vec{n}_{12} \times (\vec{H}_2 - \vec{H}_1) = \vec{J}_s \text{ or } H_{t2} - H_{t1} = J_s \quad (12b)$$

where the subscripts 1 and 2 indicate the media under consideration, and \vec{n}_{12} denotes the unit normal vector to the interface and is directed from medium 1 into medium 2. In the case where the materials are linear and isotropic equations (12a) and (12b) become

$$\vec{n}_{12} \cdot (\mu_2 \vec{H}_2 - \mu_1 \vec{H}_1) = 0 \quad (12c)$$

$$\vec{n}_{12} \times \left(\frac{\vec{B}_2}{\mu_2} - \frac{\vec{B}_1}{\mu_1} \right) = \vec{J}_s \quad (12d)$$

\vec{J}_s is a true surface current density that may exist at the interface. At an interface where \vec{J}_s is 0, equations (12b) and (12d) need to be modified accordingly.

THIN COIL SURROUNDING A FERROMAGNETIC SPHERICAL SHELL

GENERAL SOLUTION

We now proceed to solve the boundary value problem of a ferromagnetic spherical shell of outer radius R_2 , inner radius R_1 , and a homogeneous permeability μ_2 , surrounded by an infinitesimally thin current band of radius R_3 having a current density \vec{J} . A constant current density is assumed. Figure 2 identifies the four regions of interest. Regions I, III, and IV have a permeability equal to the permeability of free space μ_0 which for convenience will be labeled μ_1 . The problem's spherical symmetry suggests that a spherical coordinate system such as that shown in Figure 3 be used in the problem solution.

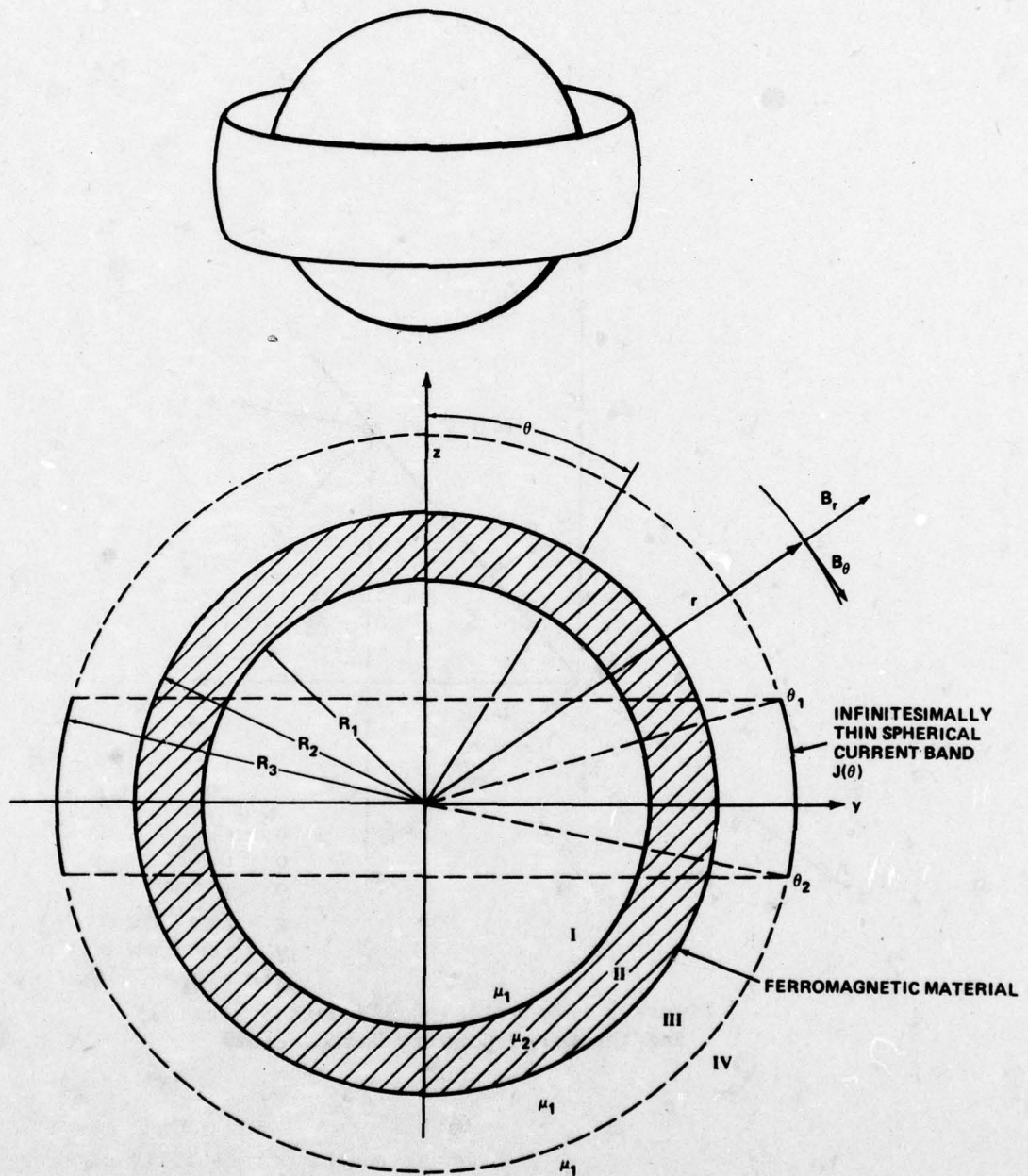

Figure 2 - Ferromagnetic Spherical Shell
Surrounded by an Infinitesimally Thin
Current Band

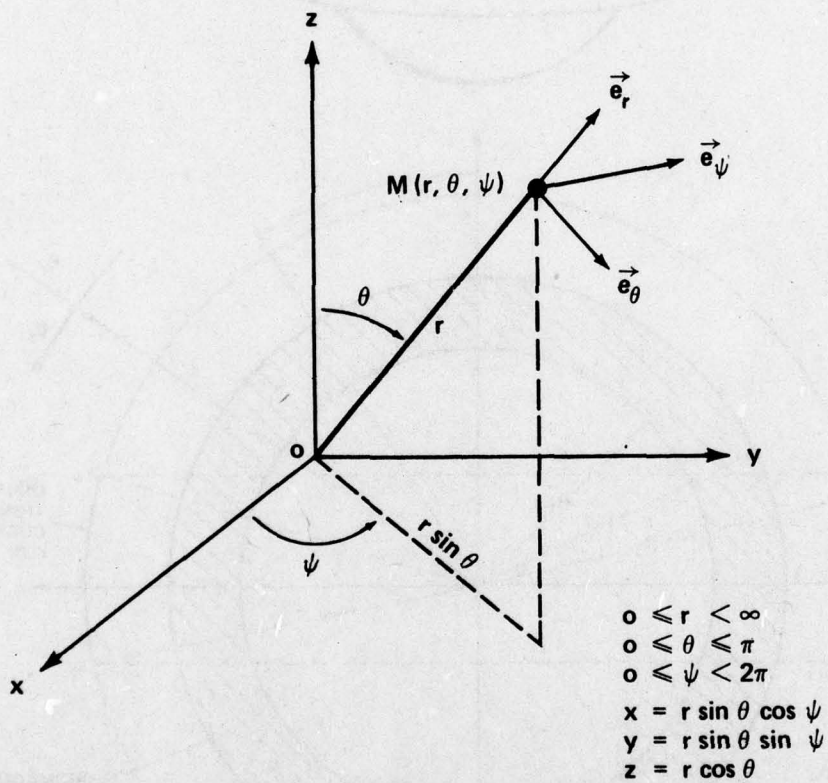

Figure 3 - Spherical Coordinate System and the Corresponding Unit Vectors

Ampere's law states

$$\vec{\nabla} \times \vec{H} = \vec{J} \quad (13)$$

and since $\vec{\nabla} \cdot \vec{B} = 0$, the induction \vec{B} must be the curl of some vector field \vec{A} . The governing differential equation for \vec{A} when homogenous and linear material are considered is from equation (11).

$$\star \vec{\nabla}^2 \vec{A} = -\mu \vec{J} \quad (14)$$

*We note that a distinction is drawn between the operator ∇^2 called the scalar Laplacian operator and the vector Laplacian operator designed by \star . The vector Poisson's equation in rectangular coordinates can be treated as three uncoupled scalar equations as shown below.

$$\begin{aligned} \star \vec{\nabla}^2 \vec{A} &= \vec{e}_x \left[\frac{\partial^2 A_x}{\partial x^2} + \frac{\partial^2 A_x}{\partial y^2} + \frac{\partial^2 A_x}{\partial z^2} \right] + \vec{e}_y \left[\frac{\partial^2 A_y}{\partial x^2} + \frac{\partial^2 A_y}{\partial y^2} + \frac{\partial^2 A_y}{\partial z^2} \right] + \\ &\vec{e}_z \left[\frac{\partial^2 A_z}{\partial x^2} + \frac{\partial^2 A_z}{\partial y^2} + \frac{\partial^2 A_z}{\partial z^2} \right] = \vec{e}_x J_x + \vec{e}_y J_y + \vec{e}_z J_z \end{aligned}$$

where $\star A_i = \nabla^2 A_i = \mu J_i$ for $i = x, y, z$. However, if the vector Poisson's equation is resolved into orthogonal components in other coordinate systems the differential operation mixes the components together giving coupled equations as shown below for spherical coordinates.

$$\begin{aligned} \star \vec{\nabla}^2 \vec{A} &= \vec{e}_r \left[\frac{\partial^2 A_r}{\partial r^2} + \frac{2}{r} \frac{\partial A_r}{\partial r} - \frac{2}{r^2} A_r + \frac{1}{r^2} \frac{\partial^2 A_r}{\partial \theta^2} + \frac{\cot \theta}{r^2} \frac{\partial A_r}{\partial \theta} + \right. \\ &\left. \frac{1}{r^2 \sin^2 \theta} \frac{\partial^2 A_r}{\partial \psi^2} - \frac{2}{r^2} \frac{\partial A_r}{\partial \theta} - \frac{2 \cot \theta}{r^2} A_\theta - \frac{2}{r^2 \sin \theta} \frac{\partial A_\psi}{\partial \psi} \right] + \\ &\vec{e}_\theta \left[\frac{\partial^2 A_\theta}{\partial r^2} + \frac{2}{r} \frac{\partial A_\theta}{\partial r} - \frac{A_\theta}{r^2 \sin^2 \theta} + \frac{1}{r^2} \frac{\partial^2 A_\theta}{\partial \theta^2} + \frac{\cot \theta}{r^2} \frac{\partial A_\theta}{\partial \theta} + \frac{1}{r^2 \sin^2 \theta} \frac{\partial^2 A_\theta}{\partial \psi^2} \right. \\ &\left. + \frac{2}{r^2} \frac{\partial A_r}{\partial \theta} - \frac{2 \cot \theta}{r^2 \sin \theta} \frac{\partial A_\psi}{\partial \psi} \right] + \vec{e}_\psi \left[\frac{\partial^2 A_\psi}{\partial r^2} + \frac{2}{r} \frac{\partial A_\psi}{\partial r} - \frac{1}{r^2 \sin^2 \theta} A_\psi + \frac{1}{r^2} \frac{\partial^2 A_\psi}{\partial \theta^2} \right. \end{aligned}$$

$$\begin{aligned}
& + \frac{\cot\theta}{r^2} \frac{\partial A_\psi}{\partial\theta} + \frac{1}{r^2 \sin^2\theta} \frac{\partial^2 A_\psi}{\partial\psi^2} + \frac{2}{r^2 \sin\theta} \frac{\partial A_r}{\partial\psi} + \frac{2 \cot\theta}{r^2 \sin\theta} \frac{\partial A_\theta}{\partial\psi} \Big] \\
& = J_r \vec{e}_r + J_\theta \vec{e}_\theta + J_\psi \vec{e}_\psi
\end{aligned}$$

The general expression in spherical coordinates for a current density is

$$\vec{J} = \vec{e}_r J_r + \vec{e}_\theta J_\theta + \vec{e}_\psi J_\psi \quad (15)$$

where the \vec{e} are the unit orthogonal vectors. For stationary currents in vacuum the vector potential function that satisfies equation (14) is given by

$$\vec{A} = \frac{\mu_0}{4\pi} \int_V \frac{\vec{J}}{r'} dv \quad (16)$$

where dv = elemental volume in the current-carrying region

r' = distance between the field point where \vec{A} is being determined and dv at the source point.

From equation (16), we see that the elemental vector potential $d\vec{A}$ due to a current element $\vec{J}dv$ is in the same direction as \vec{J} . It is well known from this that the lines of the magnetic vector potential \vec{A} are circles centered about the coil or loop axis. The magnitude of \vec{A} along such a circle is constant, which means that \vec{A} is a function of the spherical coordinates r and θ only. Therefore, we know in advance for this problem that A_ψ is the only component of \vec{A} existing at the field point. The infinitesimally thin band of current shown in Figure 2 has only an azimuthal or ψ component, which is a function of r and θ , and lies on the boundary between regions III and IV (i.e. $r = R_3$). For this current, equation (15) reduces to

$$\vec{J} = \begin{cases} 0 & , \text{ if } \theta < \theta_1 \text{ or } \theta > \theta_2 \\ \vec{e}_\psi J_\psi(\theta) & , \text{ if } \theta_1 \leq \theta \leq \theta_2 \end{cases} \quad (17)$$

Therefore, equation (14) has only an azimuthal component and can be expressed as:

$$\nabla^2 A_\psi = \nabla^2 A_\psi(r, \theta) = 0 \quad (\text{in regions I through IV}) \quad (18)$$

When the vector Laplacian ∇^2 is expanded in spherical coordinates, equation (18) can be written as

$$\frac{\partial^2 A_\psi}{\partial r^2} + \frac{2}{r} \frac{\partial A_\psi}{\partial r} + \frac{1}{r^2} \frac{\partial^2 A_\psi}{\partial \theta^2} + \frac{\cot \theta}{r^2} \frac{\partial A_\psi}{\partial \theta} - \frac{A_\psi}{r^2 \sin^2 \theta} = 0 \quad \text{in regions I through IV} \quad (19)$$

In order to solve equation (19), it is necessary to obtain the general solution in regions I through IV. Thus, by multiplying equation (19) by r^2 we obtain

$$\frac{r^2 \partial^2 A_\psi}{\partial r^2} + \frac{2r \partial A_\psi}{\partial r} + \frac{\partial^2 A_\psi}{\partial \theta^2} + \cot \theta \frac{\partial A_\psi}{\partial \theta} - \frac{A_\psi}{\sin^2 \theta} = 0 \quad (20)$$

Applying the method of separation of variables, let us assume that A_ψ can be expressed as a product of two functions

$$A_\psi = R(r)\Theta(\theta) \quad (21)$$

where $R(r)$ is a function of r only and $\Theta(\theta)$ of θ only. Substituting this form of the vector potential A_ψ into equation (20), we have after separation of variables

$$\frac{d^2 R(r)}{dr^2} + \frac{2}{r} \frac{dR(r)}{dr} - \frac{p(p+1)R(r)}{r^2} = 0 \quad (22a)$$

$$\frac{d^2 \Theta(\theta)}{d\theta^2} + \cot \theta \frac{d\Theta(\theta)}{d\theta} + \left[p(p+1) - \frac{1}{\sin^2 \theta} \right] \Theta(\theta) = 0 \quad (22b)$$

where the separation constant is $p(p+1)$ and p is an integer from one to infinity. The differential equation

$$\frac{d^2\Theta}{d\theta^2} + \cot \theta \frac{d\Theta}{d\theta} + \left[p(p+1) - \frac{m^2}{\sin^2\theta} \right] \Theta = 0 \quad (23)$$

has as a general solution

$$\Theta(\theta) = \Theta_p(\theta) = C_p P_p^m(\cos\theta) + D_p Q_p^m(\cos\theta) \quad (24)$$

Comparison of equations (22b) and (23) shows that in equation (23) m^2 is equal to 1. This requires that m always be unity. The solutions of equations (22a) and 22b) are then expressed as

$$R(r) = R_p(r) = A'_p r^p + B'_p r^{-(p+1)} \quad (25)$$

$$\Theta(\theta) = \Theta_p(\theta) = C_p P_p^1(\cos\theta) + D_p Q_p^1(\cos\theta)$$

The associated Legendre functions of the first and second kind are designated as $P_p^m(\cos\theta)$ and $Q_p^m(\cos\theta)$, respectively. Therefore, the general solution of equation (19) in regions I through IV may be formed from the product of the solutions in equation (25) which yields

$$\begin{aligned} A_\psi &= R(r)\Theta(\theta) = \sum_{p=1}^{\infty} R_p(r)\Theta_p(\theta) \\ &= \sum_{p=1}^{\infty} \left(A'_p r^p + \frac{B'_p}{r^{p+1}} \right) \left(C_p P_p^1(\cos\theta) + D_p Q_p^1(\cos\theta) \right) \end{aligned} \quad (26)$$

In the spherical case, associated Legendre functions of the second kind are infinite at $\cos\theta = \pm 1$, and thus cannot be included when the region under consideration includes the symmetry axis. Therefore, the constant D_p must be set equal to zero, and equation (26) reduces to

$$A_\psi = \sum_{p=1}^{\infty} \left(A'_p r^p + \frac{B'_p}{r^{p+1}} \right) P_p^1(\cos\theta)$$

where

$$\begin{aligned} A_p &= A'_p C_p \\ B_p &= B'_p C_p \end{aligned} \quad (27)$$

BOUNDARY CONDITIONS

The form of the potential in each of the regions (I through IV) is determined from equation (27). These magnetostatic vector potentials in regions I-IV are:

$$A_I = A_{\psi I} = \sum_{p=1}^{\infty} (A_{p1} r^p) P_p^1(\cos\theta)$$

$$A_{II} = A_{\psi II} = \sum_{p=1}^{\infty} \left[A_{p2} r^p + \frac{B_{p2}}{r^{(p+1)}} \right] P_p^1(\cos\theta) \quad (28)$$

$$A_{III} = A_{\psi III} = \sum_{p=1}^{\infty} \left[A_{p3} r^p + \frac{B_{p3}}{r^{(p+1)}} \right] P_p^1(\cos\theta)$$

$$A_{IV} = A_{\psi IV} = \sum_{p=1}^{\infty} \left[\frac{B_{p4}}{r^{(p+1)}} \right] P_p^1(\cos\theta)$$

where for the $A_{\psi I}$ component $B_{p1} = 0$ because at $r = 0$ the potential must be finite and for the $A_{\psi IV}$ component $A_{p4} = 0$ because as r approaches infinity the potential must remain finite.

At each interface, the basic laws of magnetostatics in equations (1a) and (1b) reduce to boundary conditions on \vec{B} and \vec{H} that can be used to evaluate the six constants in equation (28). From equation (1b), the normal component of \vec{B} across each boundary must be continuous, i.e., $(\vec{B}_2 - \vec{B}_1) \cdot \vec{n}_{12} = 0$ where the quantity \vec{n}_{12} is the unit outward normal to the surface. This provides the following boundary conditions which must be satisfied by the solution in equation (28) for each region.

$$B_{rI} = B_{rII} \quad \text{at } r = R_1$$

$$B_{rII} = B_{rIII} \quad \text{at } r = R_2 \quad (29)$$

$$B_{rIII} = B_{rIV} \quad \text{at } r = R_3$$

The normal component of the magnetic field B_r is expressed in terms of the vector potential as

$$B_r = (\nabla \times \vec{A})_r$$

$$B_r = \frac{1}{r \sin \theta} \frac{\partial}{\partial \theta} (\sin \theta A_\psi) \quad (30)$$

where

$$\vec{B} = \nabla \times \vec{A} = \frac{1}{r^2 \sin \theta} \begin{vmatrix} \vec{e}_r & \vec{e}_\theta r & \vec{e}_\psi r \sin \theta \\ \frac{\partial}{\partial r} & \frac{\partial}{\partial \theta} & \frac{\partial}{\partial \psi} \\ 0 & 0 & A_\psi r \sin \theta \end{vmatrix}$$

However, since the vector potentials in each region are functions of $P_p^1(\cos \theta)$ we can simplify equation (29) to constraints on A_ψ

$$A_I = A_{II} \quad \text{at } r = R_1 \quad (31a)$$

$$A_{II} = A_{III} \quad \text{at } r = R_2 \quad (31b)$$

$$A_{III} = A_{IV} \quad \text{at } r = R_3 \quad (31c)$$

The second set of boundary conditions is obtained from equation (12b). The tangential component of \vec{H} across each boundary must satisfy the relationship

$$\vec{n}_{12} \times (\vec{H}_2 - \vec{H}_1) = \vec{J}_s \quad (32)$$

where \vec{J}_s (which equals $\vec{J}(\theta)$) is the real surface current density in the limit of vanishing width between the two regions. Using the relationship $\vec{B} = \mu \vec{H}$, equation (32) may be expressed as

$$\frac{B_{\theta 2}}{\mu_2} - \frac{B_{\theta 1}}{\mu_1} = J(\theta) \quad (33)$$

Referring to the curl in equation (30), we can write B_θ as

$$B_\theta = (\vec{\nabla} \times \vec{A})_\theta = -\frac{1}{r} \frac{\partial}{\partial r} [r A_\psi] \quad (34)$$

From equations (32), (33), and (34) the tangential components in regions I-IV must satisfy the relationships.

$$-\frac{1}{\mu_2} \frac{1}{r} \frac{\partial}{\partial r} (r A_{II}) + \frac{1}{\mu_1} \frac{1}{r} \frac{\partial}{\partial r} (r A_I) = 0 \quad \text{at } r = R_1 \quad (35a)$$

$$-\frac{1}{\mu_1} \frac{1}{r} \frac{\partial}{\partial r} (r A_{III}) + \frac{1}{\mu_2} \frac{1}{r} \frac{\partial}{\partial r} (r A_{II}) = 0 \quad \text{at } r = R_2 \quad (35b)$$

$$-\frac{1}{\mu_1} \frac{1}{r} \frac{\partial}{\partial r} (r A_{IV}) + \frac{1}{\mu_1} \frac{1}{r} \frac{\partial}{\partial r} (r A_{III}) = J(\theta) \quad \text{at } r = R_3 \quad (35c)$$

The general expressions for the potentials in each region (equation (28)) are then substituted into the boundary conditions (equations (31) and (35)) and solved for the constants A_{pi} and B_{pi} . There are six algebraic equations with six unknowns and the potential in each region can then be specifically determined. The six boundary value equations that must be solved for the coefficients are given below (where the index p is odd only and understood to take on values from 1 to ∞). It is noted that the current $J_\psi(\theta)$ must be expanded into a set of associated Legendre functions in order to evaluate the constants A_{pi} and B_{pi} . The detailed expansion is in the next section entitled "Expansion of the Current ($J_\psi(\theta)$) in Associated Legendre Polynomials".

$$A_{p1} R_1^p = [A_{p2} R_1^p + B_{p2} R_1^{-(p+1)}] \quad (36a)$$

$$[A_{p2} R_2^p + B_{p2} R_2^{-(p+1)}] = [A_{p3} R_2^p + B_{p3} R_2^{-(p+1)}] \quad (36b)$$

$$[A_{p3} R_3^p + B_{p3} R_3^{-(p+1)}] = B_{p4} [R_3^{-(p+1)}] \quad (36c)$$

$$-\frac{1}{\mu_2} \left[A_{p2}^{(p+1)} R_1^{p-1} - p B_{p2} R_1^{-p-2} \right] + \frac{1}{\mu_1} \left[A_{p1}^{(p+1)} R_1^{p-1} \right] = 0 \quad (36d)$$

$$-\frac{1}{\mu_1} \left[A_{p3}^{(p+1)} R_2^{p-1} - p B_{p3} R_2^{-p-2} \right] + \frac{1}{\mu_2} \left[A_{p2}^{(p+1)} R_2^{p-1} - p B_{p2} R_2^{-p-2} \right] = 0 \quad (36e)$$

$$-\frac{1}{\mu_1} \left[-p B_{p4} R_3^{-p-2} \right] + \frac{1}{\mu_1} \left[A_{p3}^{(p+1)} R_3^{p-1} - p B_{p3} R_3^{-p-2} \right] = \frac{J_p'(\theta)}{P_p^1(\cos\theta)} \quad (36f)$$

The solution of these equations to obtain B_{p3} in terms of known quantities is performed in Appendix A. In summary:

$$B_{p3} = \frac{-\frac{1}{\mu_2} J_p''(\theta) \left([X]^{(p+1)} R_2^{(p-1)} - (p) R_2^{-p-2} \right) + \frac{1}{\mu_1} J_p'(\theta) (p+1) R_2^{(p-1)}}{\left[\left(\frac{1}{\mu_1} (p) R_2^{-p-2} \right) + \frac{1}{\mu_2} \left([Z][X]^{(p+1)} R_2^{(p-1)} \right) - \frac{1}{\mu_2} \left([Z] (p) R_2^{-p-2} \right) \right]} \quad (37a)$$

where

$$[X] = \frac{-R_1^{-(2p+1)} \left[1 + \left(\frac{p}{p+1} \right) \frac{\mu_1}{\mu_2} \right]}{\left(1 - \frac{\mu_1}{\mu_2} \right)} \quad (37b)$$

$$[Z] = \frac{R_2^{-(p+1)}}{\left([X] R_2^p + R_2^{-(p+1)} \right)} \quad (37c)$$

$$J_p''(\theta) = \frac{J_p'(\theta) R_2^p}{\left([X] R_2^p + R_2^{-(p+1)} \right)} \quad (37d)$$

$$J_p'(\theta) = \frac{\mu_1 J_p(\theta)}{P \frac{1}{p} (\cos\theta) R_3^{(p-1)} (2p+1)} \quad (37e)$$

The numerical values for the other five coefficients can be obtained from the following equations:

$$B_{p2} = B_{p3} [Z] + J_p''(\theta) \quad (38a)$$

$$A_{p3} = J_p'(\theta) \quad (38b)$$

$$A_{p2} = [X] B_{p2} \quad (38c)$$

$$A_{p1} = A_{p2} + B_{p2} R_1^{-(2p+1)} \quad (38d)$$

$$B_{p4} = A_{p3} R_3^{(2p+1)} + B_{p3} \quad (38e)$$

Since the coefficients A_{pi} and B_{pi} can be determined from equations (37) and (38), equations (28) can now be used to completely specify the potentials A_I , A_{II} , A_{III} , and A_{IV} in regions I through IV. Then the normal (B_r) and tangential (B_θ) components of the magnetic induction in regions I through IV can be determined by using equations (30) and (34), respectively.

In Appendix B the magnetic vector potentials $A_{\psi I}$ in the inner region and $A_{\psi II}$ in the outer region are derived for the infinitesimally thin current band in a homogeneous medium of permeability μ_1 (see Figure 1-B in Appendix B). Also, the dipole potential term in the outer region ($r > R_1$) for the infinitesimally thin current band is reduced in a special case to the dipole potential term for the circular filamentary current loop.

In Appendix C the coefficients A_{pi} ($i = 1, 2, 3$) and B_{pi} ($i = 2, 3, 4$) for the vector potentials for the present ferromagnetic shell problem reduce to the potentials in the two regions of the simple current band problem when the permeability of the ferromagnetic shell μ_2 approaches that of the surrounding medium μ_1 . This shows that the solutions of the above ferromagnetic current problem have the correct mathematical form.

EXPANSION OF THE CURRENT ($J_\psi(\theta)$) IN ASSOCIATED LEGENDRE POLYNOMIALS

Any function that can be expanded using a Fourier's series in a given interval $-1 < \mu' < 1$ can also be expanded in a series of associated Legendre polynomials in the same interval using similar methods. The associated Legendre functions are defined by the equation

$$P_p^m(\mu') = (1 - \mu'^2)^{\frac{1}{2}m} \frac{d^m P_p(\mu')}{d\mu'^m} \quad (39)$$

where $\mu' = \cos\theta$ and $-1 \leq \mu' \leq 1$. Also, the function $P_p(\mu')$, which is valid whatever the range of the variable μ' , is defined as

$$P_p(\mu') = \frac{1}{2^p p!} \frac{d^p}{d\mu'^p} (\mu'^2 - 1)^p \quad (40)$$

Let us assume the expansion is similar to Purczyński's⁹

$$J_\psi(\theta) = \sum_{p=1}^{\infty} J K_p P_p^1(\cos\theta) \quad (41)$$

The coefficients K_p are determined from equation (41) by multiplying both sides by $P_p^1(\cos\theta)$ and integrating over $\sin\theta d\theta$ from 0 to π .

$$K_p = \frac{(2p+1)}{2p(p+1)} \cdot \frac{1}{J} \cdot \int_0^\pi J_\psi(\theta) P_p^1(\cos\theta) \sin\theta d\theta \quad (42)$$

The identity

$$\int_0^\pi P_p^{m'}(\cos\theta) P_p^m(\cos\theta) \sin\theta d\theta = \frac{2(\ell+m)!}{(2\ell+1)(\ell-m)!} \delta_{p'p} \quad (43)$$

was used to determine K_p (equation 42). Setting $J_\psi(\theta)$ to a constant J we can express equation (42) as:

$$K_p = \frac{2p+1}{2p(p+1)} \int_0^\pi P_p^1(\cos\theta) \sin\theta d\theta \quad (44)$$

Since the current in this problem extends from $\left(\frac{\pi}{2} - \alpha\right)$ to $\left(-\frac{\pi}{2} + \alpha\right)$, see Figure 4, the expression for K_p (equation 44) may be written as

$$K_p = \frac{2p+1}{2p(p+1)} \left[\int_{\frac{\pi}{2} - \alpha}^{\frac{\pi}{2}} P_p^1(\cos\theta) \sin\theta d\theta + \int_{\frac{\pi}{2}}^{\frac{\pi}{2} + \alpha} P_p^1(\cos\theta) \sin\theta d\theta \right] \quad (45)$$

By noting that

$$P_p^1(-\cos\theta) = (-1)^{p-1} P_p^1(\cos\theta) \quad (46)$$

it follows that the associated Legendre functions $P_p^1(\cos\theta)$ are even functions with respect to $\cos\theta$ when p is odd. The expression for K_p may be simplified to

$$K_p = \frac{2p+1}{p(p+1)} \int_{\frac{\pi}{2} - \alpha}^{\frac{\pi}{2}} P_p^1(\cos\theta) \sin\theta d\theta \quad (47)$$

when p is odd ($K_p = 0$ when p is even) after utilizing the symmetry of $J(\theta)$ in Figure 5. By changing the variable in equation (47) to $\mu' = \cos\theta$, the integral for K_p may be written as

$$K_p = \frac{2p+1}{p(p+1)} \int_0^{\sin\alpha} P_p^1(\mu') d\mu' \quad (48)$$

The values of the coefficients K_p for p odd were worked out by Purczynski⁹ and are:

$$K_1 = \frac{3}{4} (\sin\alpha\cos\alpha + \alpha) \quad (49a)$$

$$K_3 = \frac{7}{64} [\sin\alpha\cos\alpha(10 \sin^2\alpha - 9) + \alpha] \quad (49b)$$

$$K_5 = \frac{11}{256} [\sin\alpha\cos\alpha(56 \sin^4\alpha - 70 \sin^2\alpha + 15) + \alpha] \quad (49c)$$

$$K_7 = \frac{15}{32768} [\sin\alpha\cos\alpha(13728 \sin^6\alpha - 23408 \sin^4\alpha + 11060 \sin^2\alpha - 1330) + 50 \alpha] \quad (49d)$$

$$K_9 = \frac{19}{327680} [\sin\alpha\cos\alpha(311168 \sin^8\alpha - 679536 \sin^6\alpha + 488488 \sin^4\alpha - 128590 \sin^2\alpha + 8715) + 245 \alpha] \quad (49e)$$

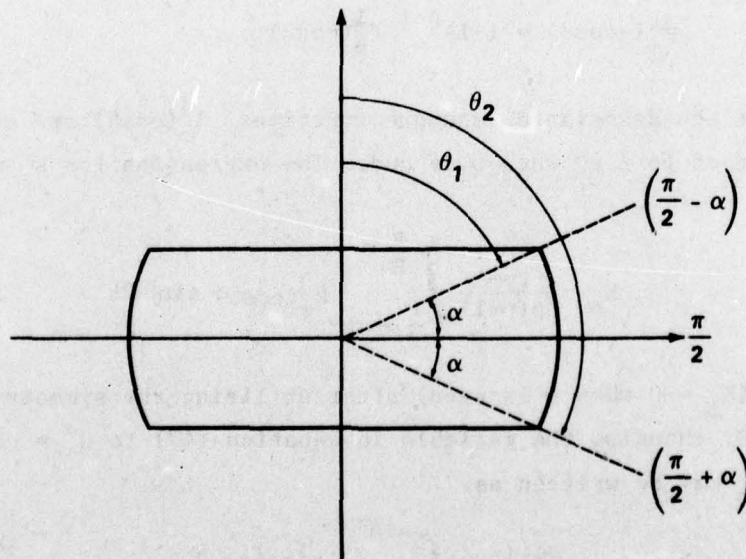

Figure 4 - Spherical Coil Cross-Sectional View - Definition of Angle Alpha

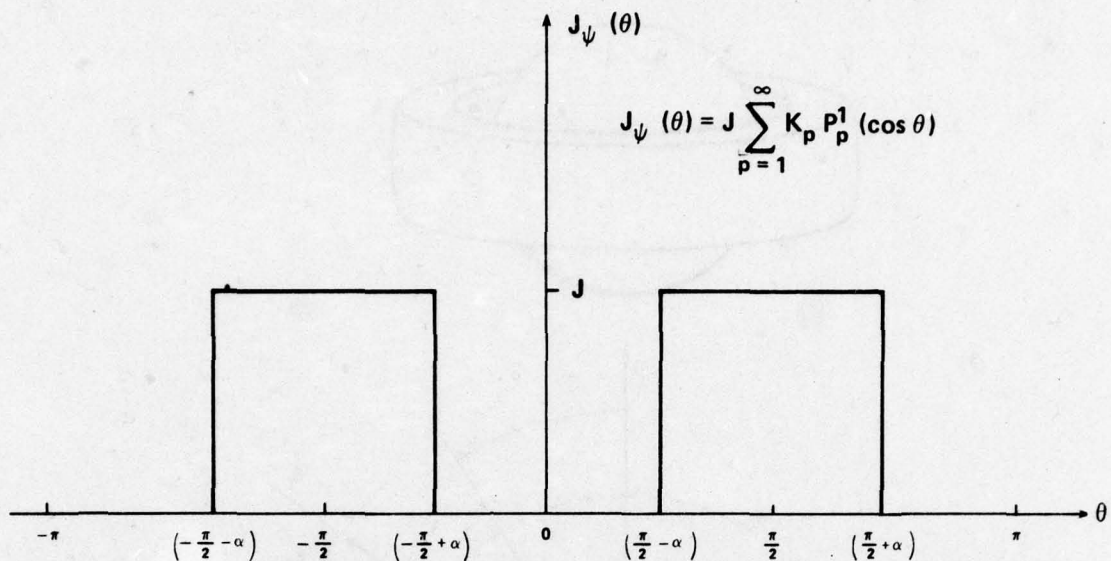

Figure 5 - Coil Current as a Function
of the Polar Angle Theta

FERROMAGNETIC SPHERE SURROUNDED
BY A COIL OF FINITE WIDTH

GENERAL SOLUTION

We now proceed to solve the boundary value problem of a solid ferromagnetic sphere of radius R_1 and homogeneous permeability μ_1 surrounded by a current band of finite width having inner radius R_2 and outer radius R_3 as shown in Figure 6. A constant current density is assumed. A linear relationship between \vec{B} and \vec{H} is assumed. Regions II, III, and IV have homogeneous free space permeability designated as μ_2 . The permeability of the conducting coil in region III is assumed, also, to be equal to μ_2 . The geometry of the problem suggests spherical symmetry as in the previous problem.

The partial differential equation that governs this problem is again equation (11),

$$\begin{aligned} \star \vec{A} &= -\mu \vec{J} & (50) \\ \vec{A} &= \vec{e}_\psi A_\psi(r, \theta) \\ \vec{J} &= \vec{e}_\psi J_\psi(r, \theta) \end{aligned}$$

where

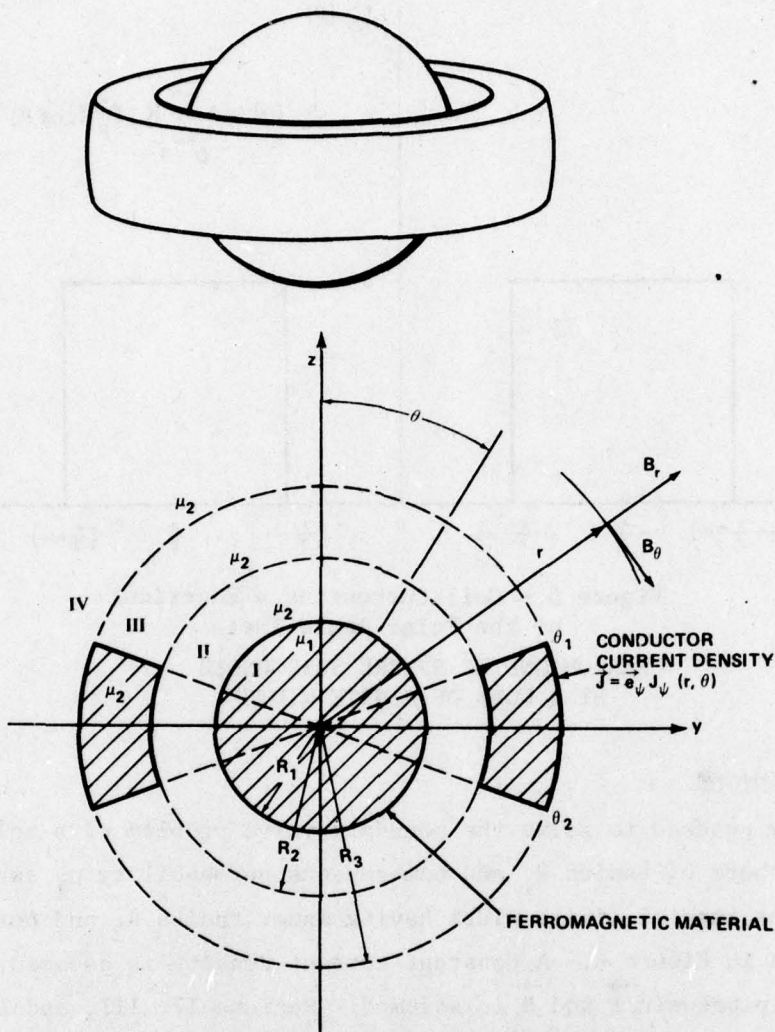

Figure 6 - Ferromagnetic Sphere Surrounded by a Coil of Finite Width (yz Plane)

As before, it is necessary to solve equation (50) and use the appropriate boundary conditions to evaluate the constants. Equation (50) reduces to

$$\star A_{\psi} = -\mu J_{\psi}(r, \theta) \quad (51)$$

where

$$J_{\psi}(r, \theta) = J_{\psi}(\theta) \text{ in region III if } \theta_1 \leq \theta \leq \theta_2 \text{ and } R_2 \leq r \leq R_3$$

$J_{\psi}(\theta) = 0$ if $\theta < \theta_1$ or $\theta > \theta_2$ for all r (θ_1 and θ_2 are defined in Figure 6).

Expanding the vector Laplacian in equation (51) in spherical coordinates results in the expression:

$$\frac{\partial^2 A_\psi}{\partial r^2} + \frac{2}{r} \frac{\partial A_\psi}{\partial r} + \frac{1}{r^2} \frac{\partial^2 A_\psi}{\partial \theta^2} + \frac{\cot \theta}{r^2} \frac{\partial A_\psi}{\partial \theta} - \frac{A_\psi}{r^2 \sin^2 \theta} = \quad (52)$$

$$\begin{cases} -\mu J_\psi(\theta) & \text{in region III} \\ 0 & \text{in regions I, II, and IV} \end{cases}$$

Thus, the solutions in regions I, II, and IV are solutions of Laplace's equation and are obtained by the method of separation of variables as in the previous problem. The potential solution in region III, however, is the solution of Poisson's equation.

The potentials in regions I, II, III, and IV are:

$$A_I = A_{\psi I} = \sum_{p=1}^{\infty} (A_{p1} r^p) P_p^1(\cos \theta) \quad (53a)$$

$$A_{II} = A_{\psi II} = \sum_{p=1}^{\infty} \left(A_{p2} r^p + \frac{B_{p2}}{r^{(p+1)}} \right) P_p^1(\cos \theta) \quad (53b)$$

$$A_{III} = A_{\psi III} = \sum_{p=1}^{\infty} \left(A_{p3} r^p + \frac{B_{p3}}{r^{(p+1)}} \right) P_p^1(\cos \theta) + \sum_{\substack{p \neq 2 \\ p=1}}^{\infty} \left(\frac{\mu J_r^2 K_p}{(p-2)(p+3)} \right) P_p^1(\cos \theta) \quad (53c)$$

$$A_{IV} = A_{\psi IV} = \sum_{p=1}^{\infty} \left(\frac{B_{p4}}{r^{(p+1)}} \right) P_p^1(\cos \theta) \quad (53d)$$

Equation (53c), the azimuthal component of Poisson's equation in spherical coordinates, is solved in detail in Appendix D. When the current is expanded in associated Legendre functions we have

$$J_{\psi}(r, \theta) = J(\theta) = J \sum_{p=1}^{\infty} K_p P_p^1(\cos\theta) \quad (54)$$

where only the odd coefficients contribute since the even coefficients are zero. The coefficients for the current were derived previously (see equations (49a through 49e)).

BOUNDARY CONDITIONS

This solution must satisfy the boundary conditions developed in equations (29) through (33). Because there are no surface currents on the boundary between the regions in this ferromagnetic problem, \vec{J}_s is zero and the tangential boundary conditions for regions I-IV become

$$\frac{1}{\mu_2} \frac{1}{r} \frac{\partial}{\partial r} (rA_{II}(r, \theta)) = \frac{1}{\mu_1} \frac{1}{r} \frac{\partial}{\partial r} (rA_I(r, \theta)) \text{ at } r = R_1 \quad (55a)$$

$$\frac{1}{\mu_2} \frac{1}{r} \frac{\partial}{\partial r} (rA_{III}(r, \theta)) = \frac{1}{\mu_2} \frac{1}{r} \frac{\partial}{\partial r} (rA_{II}(r, \theta)) \text{ at } r = R_2 \quad (55b)$$

$$\frac{1}{\mu_2} \frac{1}{r} \frac{\partial}{\partial r} (rA_{IV}(r, \theta)) = \frac{1}{\mu_2} \frac{1}{r} \frac{\partial}{\partial r} (rA_{III}(r, \theta)) \text{ at } r = R_3 \quad (55c)$$

The general expressions for the potentials in each region (equation (53)) are then substituted into the boundary conditions (equations (31) and (55)) and solved for the A_{pi} 's and B_{pi} 's. There are six algebraic equations with six unknowns and the potential in each region can then be specifically determined. The six boundary conditions that must be solved for the coefficients are (where the index p is odd only and understood to take the values 1 to ∞):

$$A_{p1} R_1^p = A_{p2} R_1^p + B_{p2} R_1^{-(p+1)} \quad (56a)$$

$$A_{p2}R_2^p + B_{p2}R_2^{-(p+1)} = A_{p3}R_2^p + B_{p3}R_2^{-(p+1)} + \frac{\mu_2 JR_2^2 K_p}{(p-2)(p+3)} \quad (56b)$$

$$A_{p3}R_3^p + B_{p3}R_3^{-(p+1)} + \frac{\mu_2 JR_3^2 K_p}{(p-2)(p+3)} = B_{p4}R_3^{-(p+1)} \quad (56c)$$

$$\frac{1}{\mu_2} \left[A_{p2}^{(p+1)} R_1^{p-1} - (p) B_{p2} R_1^{-p-2} \right] = \frac{1}{\mu_1} \left[A_{p1}^{(p+1)} R_1^{p-1} \right] \quad (56d)$$

$$\frac{1}{\mu_2} \left[A_{p3}^{(p+1)} R_2^{p-1} - (p) B_{p3} R_2^{-p-2} + \frac{3\mu_2 JR_2 K_p}{(p-2)(p+3)} \right] =$$

$$\frac{1}{\mu_2} \left[A_{p2}^{(p+1)} R_2^{p-1} - (p) B_{p2} R_2^{-p-2} \right] \quad (56e)$$

$$\frac{1}{\mu_2} \left[-(p) B_{p4} R_3^{-p-2} \right] = \frac{1}{\mu_2} \left[A_{p3}^{(p+1)} R_3^{p-1} - (p) B_{p3} R_3^{-p-2} +$$

$$\frac{3\mu_2 JR_3 K_p}{(p-2)(p+3)} \right] \quad (56f)$$

The mathematical solution for B_{p3} in terms of known quantities obtained in Appendix E and is given by

$$B_{p3} = \left\{ -K_p' (p+1) R_2^{(p-1)} - \frac{3\mu_2 JR_2 K_p}{(p-2)(p+3)} \right. \quad (57a)$$

$$\left. + [X] (p+1) R_2^{p-1} K_p'' - (p) R_2^{-p-2} K_p''' \right\} /$$

$$\left\{ (-p) R_2^{-p-2} - [Z][X] (p+1) R_2^{p-1} + [Z] (p) R_2^{-p-2} \right\}$$

$$[X] = \frac{-R_1^{-(2p+1)} \left[1 + \left(\frac{p}{p+1} \right) \frac{\mu_1}{\mu_2} \right]}{\left(1 - \frac{\mu_1}{\mu_2} \right)} \quad (57b)$$

$$K'_p = - \frac{\mu_2 J K_p R_3^{-p+2}}{(p-2)(2p+1)} \quad (57c)$$

$$[Z] = \frac{R_2^{-(p+1)}}{\left([X] R_2^p + R_2^{-(p+1)} \right)} \quad (57d)$$

$$K''_p = \frac{\frac{\mu_2 J R_2^2 K_p}{(p-2)(p+3)} + K'_p R_2^p}{\left([X] R_2^p + R_2^{-(p+1)} \right)} \quad (57e)$$

The numerical values for the other coefficients can be obtained from the equations

$$A_{p3} = K'_p \quad (58a)$$

$$B_{p2} = B_{p3} [Z] + K''_p \quad (58b)$$

$$A_{p2} = [X] B_{p2} \quad (58c)$$

$$A_{p1} = A_{p2} + B_{p2} R_1^{-(2p+1)} \quad (58d)$$

$$B_{p4} = A_{p3} R_3^{(2p+1)} + B_{p3} + \frac{\mu_2 J R_3^{(p+3)} K_p}{(p-2)(p+3)} \quad (58e)$$

CONCLUSIONS AND RECOMMENDATIONS

The method of separation of variables has been applied to determine the magnetic field of the systems consisting of an infinitesimally thin spherical coil around (outside) a ferromagnetic spherical shell and a spherical current band of finite width around a solid ferromagnetic sphere. The resulting formulae can be used in the analysis of magnetic induction of ferromagnetic bodies due to current-carrying coils.

The magnetic vector potentials in the inner and outer regions are derived for the infinitesimally thin current band in a medium of homogeneous permeability. The dipole term for the potential on the outer region for the infinitesimally thin current band is reduced in a special case to the dipole potential term for the circular filamentary current loop. It is also shown that the vector potential for the ferromagnetic shell surrounded by a infinitesimally thin current band reduce to the potential in the two regions of the simple current band problem when the permeability of the ferromagnetic shell approaches that of the surrounding medium.

It is recommended that the solutions derived in this report be programmed on a digital computer. The resulting calculations should then be compared to solutions obtained by various numerical methods in order to validate the numerical methods and calculations. There are plans to implement these recommendations during the fiscal years 1979 and 1980.

ACKNOWLEDGMENT

The authors gratefully acknowledge the technical comments and suggestions from Mr. Darrel A. Nixon and Dr. B. R. Hood of this Center and Dr. J. P. Wilswo of Vanderbilt University, a Navy consultant.

APPENDIX A
 CALCULATION OF COEFFICIENTS OF THE VECTOR
 POTENTIALS FOR A THIN COIL SURROUNDING
 A FERROMAGNETIC SPHERICAL SHELL

In this appendix the coefficients are derived for the vector potentials in regions I-IV for a ferromagnetic spherical shell surrounded by an infinitely thin current band. For a detailed discussion of the ferromagnetic problem see the section in the text of the report entitled "Thin Coil Surrounding a Ferromagnetic Spherical Shell". The magnetic vector potentials in each region are given by:

$$A_{\psi I} = \sum_{p=1}^{\infty} (A_{p1} r^p) P_p^1(\cos\theta) \quad (A-1a)$$

$$A_{\psi II} = \sum_{p=1}^{\infty} \left(A_{p2} r^p + \frac{B_{p2}}{r^{(p+1)}} \right) P_p^1(\cos\theta) \quad (A-1b)$$

$$A_{\psi III} = \sum_{p=1}^{\infty} \left(A_{p3} r^p + \frac{B_{p3}}{r^{(p+1)}} \right) P_p^1(\cos\theta) \quad (A-1c)$$

$$A_{\psi IV} = \sum_{p=1}^{\infty} \left(\frac{B_{p4}}{r^{(p+1)}} \right) P_p^1(\cos\theta) \quad (A-1d)$$

The coefficients (A_{pi} and B_{pi}) in equations A-1a to A-1d are obtained by substituting these equations into the boundary conditions (equations (A-2a to A-2f)).

$$A_I = A_{II} \text{ at } r = R_1 \quad (A-2a)$$

$$A_{II} = A_{III} \text{ at } r = R_2 \quad (A-2b)$$

$$A_{III} = A_{IV} \text{ at } r = R_3 \quad (A-2c)$$

$$-\frac{1}{\mu_2} \frac{1}{r} \frac{\partial}{\partial r} (rA_{II}) + \frac{1}{\mu_1} \frac{1}{r} \frac{\partial}{\partial r} (rA_I) = 0 \text{ at } r = R_1 \quad (\text{A-2d})$$

$$-\frac{1}{\mu_1} \frac{1}{r} \frac{\partial}{\partial r} (rA_{III}) + \frac{1}{\mu_2} \frac{1}{r} \frac{\partial}{\partial r} (rA_{II}) = 0 \text{ at } r = R_2 \quad (\text{A-2e})$$

$$-\frac{1}{\mu_1} \frac{1}{r} \frac{\partial}{\partial r} (rA_{IV}) + \frac{1}{\mu_1} \frac{1}{r} \frac{\partial}{\partial r} (rA_{III}) = J(\theta) \text{ at } r = R_3 \quad (\text{A-2f})$$

After appropriate substitutions of equations A-1a to A-1d into equations A-2a to A-2f, the following boundary value equations are obtained.

$$(A_{p1} R_1^p) = \left(A_{p2} R_1^p + \frac{B_{p2}}{R_1^{(p+1)}} \right) \quad (\text{A-3a})$$

$$\left(A_{p2} R_2^p + \frac{B_{p2}}{R_2^{(p+1)}} \right) = \left(A_{p3} R_2^p + \frac{B_{p3}}{R_2^{(p+1)}} \right) \quad (\text{A-3b})$$

$$\left(A_{p3} R_3^p + \frac{B_{p3}}{R_3^{(p+1)}} \right) = \left(\frac{B_{p4}}{R_3^{(p+1)}} \right) \quad (\text{A-3c})$$

$$-\frac{1}{\mu_2} \left[A_{p2} (p+1) R_1^{p-1} - (p) B_{p2} R_1^{-p-2} \right] + \frac{1}{\mu_1} \left[A_{p1} (p+1) R_1^{p-1} \right] = 0 \quad (\text{A-3d})$$

$$-\frac{1}{\mu_1} \left[A_{p3} (p+1) R_2^{p-1} - (p) B_{p3} R_2^{-p-2} \right] + \frac{1}{\mu_2} \left[A_{p2} (p+1) R_2^{p-1} - (p) B_{p2} R_2^{-p-2} \right] = 0 \quad (\text{A-3e})$$

$$\begin{aligned}
& -\frac{1}{\mu_1} \left[(-p) B_{p4} R_3^{-p-2} \right] + \frac{1}{\mu_1} \left[A_{p3} (p+1) R_3^{(p-1)} - (p) B_{p3} R_3^{-p-2} \right] \\
& = \frac{J_p(\theta)}{P_p^1(\cos\theta)} \tag{A-3f}
\end{aligned}$$

These algebraic equations provide six simultaneous equations with six unknowns, and they can be solved for the coefficients A_{pi} and B_{pi} by tedious algebraic manipulation.

Solving equations (A-3a and A-3d) algebraically results in the solution for A_{p2} in terms of B_{p2} .

$$A_{p2} = [X] B_{p2} \tag{A-4}$$

where

$$[X] = \frac{-R_1^{-(2p+1)} \left[1 + \left(\frac{P}{p+1} \right) \frac{\mu_1}{\mu_2} \right]}{\left(1 - \frac{\mu_1}{\mu_2} \right)}$$

The solution for A_{p1} from equation (A-3a) is

$$A_{p1} = A_{p2} + B_{p2} R_1^{-(2p+1)} \tag{A-5}$$

Also, solving equations (A-3c) and (A-3f) algebraically for B_{p4} gives the expression for A_{p3} in terms of known quantities after equating the functions for B_{p4} to B_{p4} from each equation. Thus,

$$A_{p3} = J'_p(\theta) \tag{A-6}$$

where

$$J'_p(\theta) = \frac{\mu_1 J_p(\theta)}{P_p^1(\cos\theta) R_3^{(p-1)} (2p+1)}$$

The algebraic solution for B_{p4} from equation (A-3c) is

$$B_{p4} = A_{p3} R_3^{(2p+1)} + B_{p3} \quad (A-7)$$

The following expression is obtained for B_{p2} from equation (A-3b) after substituting the expressions for A_{p3} (equation A-6), and A_{p2} (equation A-4).

$$B_{p2} = B_{p3} [Z] + J_p''(\theta) \quad (A-8)$$

where

$$[Z] = \frac{R_2^{-(p+1)}}{([X] R_2^p + R_2^{-(p+1)})}$$

and

$$J_p''(\theta) = \frac{J_p'(\theta) R_2^p}{([X] R_2^p + R_2^{-(p+1)})}$$

The mathematical solution for B_{p3} in terms of known quantities is obtained from equation (A-3e) by substituting the previously obtained expressions for A_{p3} (equation A-6), A_{p2} (equation A-4), and B_{p2} (equation A-8).

$$B_{p3} = \frac{-\frac{1}{\mu_2} J_p''(\theta) \left([X] (p+1) R_2^{(p-1)} - (p) R_2^{-p-2} \right) + \frac{1}{\mu_1} J_p'(\theta) (p+1) R_2^{(p-1)}}{\left[\left(\frac{1}{\mu_1} (p) R_2^{-p-2} \right) + \frac{1}{\mu_2} \left([Z] [X] (p+1) R_2^{(p-1)} \right) - \frac{1}{\mu_2} \left([Z] p R_2^{-p-2} \right) \right]} \quad (A-9a)$$

where

$$[X] = \frac{-R_1^{-(2p+1)} \left[1 + \left(\frac{p}{p+1} \right) \frac{\mu_1}{\mu_2} \right]}{\left(1 - \frac{\mu_1}{\mu_2} \right)} \quad (A-9b)$$

$$[z] = \frac{R_2^{-(p+1)}}{\left([X] R_2^p + R_2^{-(p+1)} \right)} \quad (\text{A-9c})$$

$$J_p''(\theta) = \frac{J_p'(\theta) R_2^p}{\left([X] R_2^p + R_2^{-(p+1)} \right)} \quad (\text{A-9d})$$

$$J_p'(\theta) = \frac{\mu_{1p} J_p(\theta)}{P_p^1 (\cos \theta) R_3^{(p-1)} (2p+1)} \quad (\text{A-9e})$$

After the numerical value for B_{p3} is calculated on the computer for a specific problem, the numerical values for the other coefficients can be obtained from the following equations:

$$B_{p2} = B_{p3} [z] + J_p''(\theta), \quad (\text{see equation A-8}) \quad (\text{A-10a})$$

$$A_{p3} = J_p'(\theta), \quad (\text{see equation A-6}) \quad (\text{A-10b})$$

$$A_{p2} = [X] B_{p2}, \quad (\text{see equation A-4}) \quad (\text{A-10c})$$

$$A_{p1} = A_{p2} + B_{p2} R_1^{-(2p+1)}, \quad (\text{see equation A-5}) \quad (\text{A-10d})$$

$$B_{p4} = A_{p3} R_3^{(2p+1)} + B_{p3} \quad (\text{see equation A-7}) \quad (\text{A-10e})$$

APPENDIX B
 DETERMINATION OF POTENTIALS FOR INFINITESIMALLY
 THIN CURRENT BAND AND INFINITESIMALLY THIN COIL

In this appendix the potentials $A_{\psi I}$ in the inner region and $A_{\psi II}$ in the outer region are derived for the infinitesimally thin current band in a homogeneous medium of permeability μ_1 (see Figure 1-B). Also, the potential in the outer region ($r > R_1$) for the infinitesimally thin coil is shown to reduce to the potential of the circular filamentary current loop.

The potentials in the inner region $A_{\psi I}$ and outer region $A_{\psi II}$ of the infinitesimally thin current band problem are solutions to the vector Laplace's equation $\nabla \cdot \vec{A} = 0$. These solutions can be expressed as:

$$A_{\psi I} = \sum_{p=1}^{\infty} (A_{p1} r^p) P_p^1(\cos\theta) \quad (B-1a)$$

$$A_{\psi II} = \sum_{p=1}^{\infty} \left(\frac{B_{p2}}{r^{(p+1)}} \right) P_p^1(\cos\theta) \quad (B-1b)$$

The coefficients A_{p1} and B_{p2} are determined from the boundary conditions of the problem. After algebraic manipulation such as with equations (31) and (35) in the text, the boundary conditions for the normal component of \vec{B} and the tangential component of \vec{H} become:

$$A_{\psi I} = A_{\psi II} \text{ at } r = R_1 \quad (B-2a)$$

$$-\frac{1}{\mu_1} \frac{1}{r} \frac{\partial}{\partial r} (r A_{II}) + \frac{1}{\mu_1} \frac{1}{r} \frac{\partial}{\partial r} (r A_I) = J_{\psi}(\theta) \text{ at } r = R_1 \quad (B-2b)$$

Substituting the expressions for $A_{\psi I}$ and $A_{\psi II}$ (equations B-1a and B-1b) into the boundary value equations (equations B-2a and B-2b) provides us with the following algebraic equations for the coefficients:

$$A_{p1} R_1^p = B_{p2} R_1^{-(p+1)} \quad (B-3a)$$

$$- \frac{1}{\mu_1} \left[(-p) B_{p2} R_1^{-p-2} \right] \quad (B-3b)$$

$$+ \frac{1}{\mu_1} \left[A_{p1} (p+1) R_1^{p-1} \right] = J_p(\theta) / P_p^1(\cos\theta)$$

where $J_p(\theta)$ is the p^{th} term of $J_\psi(\theta)$ (see equation 41). These equations are solved for A_{p1} and B_{p2} by simple algebraic manipulation.

$$A_{p1} = B_{p2} R_1^{-2p-1} \quad (B-4a)$$

$$B_{p2} = \frac{\mu_1 J_p(\theta) / P_p^1(\cos\theta)}{R_1^{-p-2} (2p+1)} \quad (B-4b)$$

The potential $A_{\psi II}$ is determined by substituting the expression for B_{p2} (equation B-4b) into equation (B-1b).

$$A_{\psi II} = \sum_{p=1}^{\infty} \left[\frac{\mu_1 J_p(\theta) / P_p^1(\cos\theta)}{r^{(p+1)} (2p+1) R_1^{-p-2}} \right] P_p^1(\cos\theta) \quad (B-5a)$$

$$= \sum_{p=1}^{\infty} \frac{\mu_1 J_{Kp} P_p^1(\cos\theta) R_1}{(2p+1)} \left(\frac{R_1}{r} \right)^{p+1} \quad (B-5b)$$

where $J_p(\theta) = J_{Kp} P_p^1(\cos\theta)$ (B-5c)

and $J_{Kp} = \frac{2p+1}{2p(p+1)} \int_0^\pi J(\theta) P_p^1(\cos\theta) \sin\theta d\theta$ (B-5d)

$A_{\psi II}$ is the potential in region 2 which is external to the coil (see Figure 1-B).

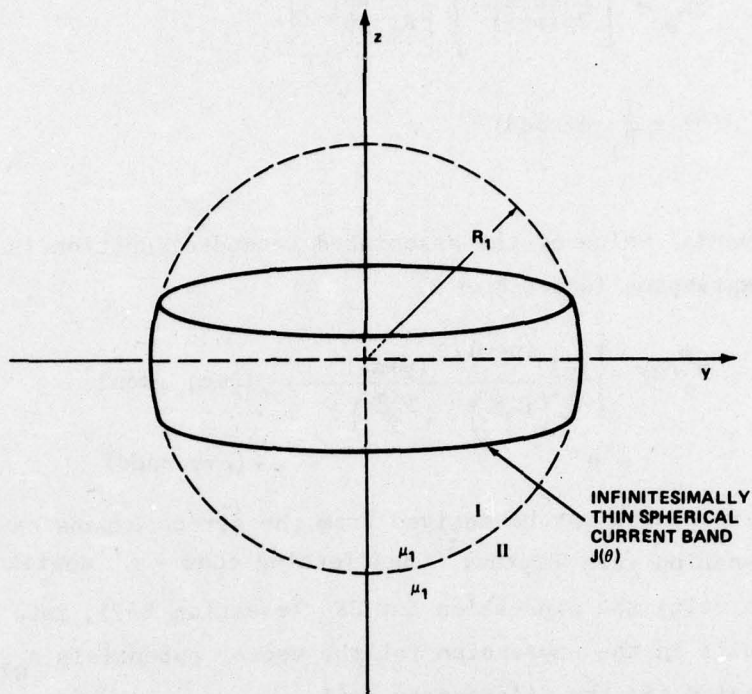

Figure 1-B - Infinitesimally Thin Current Band

Now the solution for $A_{\psi II}$ (equation B-5b) can be reduced to that for the filamentary coil and the answer compared with that for the same problem from a standard text (Jackson,¹⁰ page 144, equation (5.46)).

The coefficient JK_p for the expansion of the current

$$J_{\psi}(\theta) = \sum_p JK_p P_p^1(\cos \theta) \quad (B-6)$$

for the current filament is obtained from the equation (see equation B-5d):

$$\begin{aligned}
 JK_p &= - \frac{2p+1}{2p(p+1)} \int_{\cos(0)}^{\cos(\pi)} \frac{I}{R_1} \delta(\cos \theta) P_p^1(\cos \theta) d(\cos \theta) \quad (B-7) \\
 &= - \frac{I}{R_1} \left(\frac{2p+1}{2p(p+1)} \right) P_p^1(0)
 \end{aligned}$$

$$JK_p = \left[\frac{-(2p+1)}{2p(p+1)} \right] \left[\frac{I}{R_1} P_p^1(0) \right]$$

where $J(\theta) = \frac{I}{R_1} \delta(\cos\theta)$

The special value of the associated Legendre function is calculated from the expression (where $m = 1$)

$$P_p^m(0) = \begin{cases} \frac{(-1)^{(p-m)/2} (p+m)!}{2^p \left(\frac{p-m}{2}\right)! \left(\frac{p+m}{2}\right)!}, & (p+m, \text{ even}) \\ = 0 & (p+m, \text{ odd}) \end{cases} \quad (\text{B-8})$$

This expression may be derived from the series expansion for the Legendre function (see Smythe)¹¹ and letting $\cos\theta = \mu'$ approach 0.

Substituting the expression for JK_p (equation B-7), into equation (B-5b), results in the expression for the vector potentials $A_{\psi II}$ in the external region for the filamentary coil.

$$A_{\psi II} = - \sum_{p=1}^{\infty} \frac{\mu_1 I P_p^1(\cos\theta)}{(2p)(p+1)} \left(\frac{R_1}{r} \right)^{p+1} P_p^1(0) \quad (\text{B-9a})$$

Now equation (B-9a) must be multiplied by $\frac{4\pi}{c}$ to change from SI units to Gaussian units, and μ_1 must be set equal to 1 as μ_1 is the free space permeability which equals 1 in the Gaussian system.

After making these substitutions we have

$$A_{\psi II} = - \frac{4\pi}{c} \sum_{p=1}^{\infty} \frac{I P_p^1(\cos\theta)}{2p(p+1)} \left(\frac{R_1}{r} \right)^{p+1} P_p^1(0) \quad (\text{B-9b})$$

Now taking the first term ($p=1$) for use in the comparison with the result in Jackson¹⁰ we have

$$A_{\psi_{II}(p=1)} = -\frac{I\pi}{c} \left(\frac{R_1}{r}\right)^2 P_1^1(\cos\theta) \quad (B-9c)$$

This expression agrees exactly with the expression in Jackson¹⁰ for the first term in the series where $R_1 = a$ in his notation.¹⁰ The magnetic fields far from the loop for the $p=1$ term are dipole in character.

The $A_{\psi_{I}(p=1)}$ term for the current band problem also reduces exactly to Jackson's term with $n=0$ (Jackson,¹⁰ page 144, equation 5.46) for the potential inside of the loop.

APPENDIX C

REDUCTION OF THE MAGNETIC VECTOR POTENTIAL FOR A THIN COIL SURROUNDING A FERROMAGNETIC SPHERICAL SHELL TO THAT OF A THIN COIL IN FREE SPACE WHEN IN THE LIMIT μ_1 EQUALS μ_2

In this appendix, the coefficients A_{p1} , A_{p2} , A_{p3} , B_{p2} , B_{p3} , and B_{p4} for the potentials are evaluated for the system consisting of a ferromagnetic shell with permeability μ_2 surrounded by an infinitesimally thin current band in a homogeneous medium with permeability μ_1 in the limit as $\mu_1 = \mu_2$. These coefficients are utilized in equation (28) in the section of the report entitled "Thin Coil Surrounding a Ferromagnetic Spherical Shell". The variables are defined in Figure 2 located in the text of this report. When μ_1 is set equal to μ_2 the problem reduces to that of finding the potentials in the two regions of a simple current band (see Figure 1-B in Appendix B), since the ferromagnetic shell will now have a permeability μ_1 equal to that of the homogeneous medium with permeability μ_1 .

In this limit the coefficients should assume the following form:

$$A_{p1} = A_{p2} = A_{p3} \quad (C-1a)$$

$$B_{p2} = B_{p3} = 0 \quad (C-1b)$$

and where A_{p1} and B_{p4} should reduce to the coefficients for the potentials in the two regions for the spherical band problem (see Appendix B). If the coefficients assume this mathematical form it will prove that the mathematical form of the coefficients for the spherical shell surrounded by a thin current loop are mathematically correct.

The mathematical solution for B_{p3} in terms of known quantities was derived in Appendix A and was reported in the text of this report (see equation (37a)).

$$B_{p3} = \frac{-\frac{1}{\mu_2} J_p''(\theta) \left([X] (p+1)R_2^{p-1} - (p)R_2^{-p-2} \right) + \frac{1}{\mu_1} J_p'(\theta) (p+1)R_2^{p-1}}{\left[\left(\frac{1}{\mu_1} (p)R_2^{-p-2} \right) + \frac{1}{\mu_2} \left([Z][X] (p+1)R_2^{p-1} \right) - \frac{1}{\mu_2} \left([Z] (p)R_2^{-p-2} \right) \right]} \quad (C-2a)$$

where

$$[X] = \frac{-R_1^{-(2p+1)} \left[1 + \left(\frac{p}{p+1} \right) \frac{\mu_1}{\mu_2} \right]}{\left(1 - \frac{\mu_1}{\mu_2} \right)} \quad (C-2b)$$

$$[Z] = \frac{R_2^{-(p+1)}}{\left([X] R_2^p + R_2^{-(p+1)} \right)} \quad (C-2c)$$

$$J_p''(\theta) = \frac{J_p'(\theta) R_2^p}{\left([X] R_2^p + R_2^{-(p+1)} \right)} \quad (C-2d)$$

$$J_p'(\theta) = \frac{\mu_1 J_p(\theta)}{P_p^1(\cos\theta) R_3^{(p-1)} (2p+1)} \quad (C-2e)$$

The coefficient B_{p3} will now be evaluated when the limit is taken with $\mu_1 = \mu_2$ which cause $[X]$ to approach infinity (∞). Also, the expression for $J_p''(\theta)$ is substituted into equation (C-2a).

$$\begin{aligned}
& \left. \begin{aligned} & - \frac{1}{\mu_1} \left(\frac{J'_p(\theta) R_2^p}{R_2^p + \frac{R_2^{-(p+1)}}{[X]}} \right) \left((p+1) R_2^{p-1} - \frac{(p) R_2^{-(p+2)}}{[X]} \right) + \frac{1}{\mu_1} J'_p(\theta) (p+1) R_2^{p-1} \end{aligned} \right\} \\
B_{p3} \Big|_{(\mu_1 = \mu_2)} &= \lim_{[X] \rightarrow \infty} \left\{ \frac{(p) R_2^{-(p+2)}}{\mu_1} + \frac{1}{\mu_1} \left(\frac{R_2^{p-1} R_2^{-(p+1)} (p+1)}{R_2^p + \frac{R_2^{-(p+1)}}{[X]}} \right) - \frac{1}{\mu_1} \left(\frac{(p) R_2^{-(p+2)} R_2^{-(p+1)}}{[X] R_2^p + R_2^{-(p+1)}} \right) \right\}
\end{aligned}$$

(C-3)

$$= \left[- \frac{1}{\mu_1} \left(J'_p(\theta) (p+1) R_2^{p-1} \right) + \frac{1}{\mu_1} \left(J'_p(\theta) (p+1) R_2^{p-1} \right) \right] / \left[\frac{(p) R_2^{-(p+2)}}{\mu_1} + \frac{1}{\mu_1} \left(\frac{(p+1) R_2^{-(p-1)} R_2^{-(p+1)}}{R_2^p} \right) \right]$$

$$B_{p3} \Big|_{(\mu_1 = \mu_2)} = 0$$

The expression for A_{p2} (see equations (38c) and (38a) in the text is:

$$A_{p2} = [X] B_{p2} = [X] B_{p3} [Z] + [X] J_p''(\theta) \quad (C-4a)$$

where $B_{p2} = B_{p3} [Z] + J_p''(\theta)$ (C-4b)

The expression for A_{p2} when μ_1 equals μ_2 can be expressed as

$$A_{p2} \Big|_{(\mu_1=\mu_2)} = \lim_{[X] \rightarrow \infty} \left([X] \begin{bmatrix} B_{p3} \\ (\mu_1=\mu_2) \end{bmatrix} [Z] \right) + \lim_{[X] \rightarrow \infty} ([X] J_p''(\theta)) \quad (C-5)$$

$$A_{p2} \Big|_{(\mu_1=\mu_2)} = J_p'(\theta)$$

where $\lim_{[X] \rightarrow \infty} ([X] [Z]) = \lim_{[X] \rightarrow \infty} \left(\frac{[X] R_2^{-(p+1)}}{[X] R_2^p + R_2^{-(p+1)}} \right) =$

$$\lim_{[X] \rightarrow \infty} \left(\frac{R_2^{-(p+1)}}{R_2^p + \frac{R_2^{-(p+1)}}{[X]}} \right) = R_2^{-(2p+1)}$$

and $\lim_{[X] \rightarrow \infty} ([X] J_p''(\theta)) =$

$$\lim_{[X] \rightarrow \infty} \left(\frac{[X] J_p'(\theta) R_2^p}{[X] \left(R_2^p + \frac{R_2^{-(p+1)}}{[X]} \right)} \right) = J_p'(\theta) \quad (C-6)$$

and $B_{p3} \Big|_{(\mu_1=\mu_2)} = 0$, (see equation C-3).

The expression for $A_{p3} \Big|_{(\mu_1=\mu_2)}$ equals $J_p'(\theta)$ (see equation (38b) in the text of this report). The expression for B_{p2} (see equation (38a) in text of this report) is:

$$B_{p2} = B_{p3} [Z] + J_p''(\theta) \quad (C-7)$$

The expression for B_{p2} when $\mu_1 = \mu_2$ can be expressed as:

$$B_{p2} \Big|_{(\mu_1=\mu_2)} = \lim_{[X] \rightarrow \infty} \left(\left[B_{p3} \Big|_{(\mu_1=\mu_2)} \right] [Z] \right) + \lim_{[X] \rightarrow \infty} \left(\frac{J_p'(\theta) R_2^p}{[X] R_2^p + R_2^{-(p+1)}} \right) \quad (C-8)$$

$$B_{p2} \Big|_{(\mu_1=\mu_2)} = 0$$

where $\lim_{[X] \rightarrow \infty} [Z] = \lim_{[X] \rightarrow \infty} \left(\frac{R_2^{-(p+1)}}{[X] R_2^p + R_2^{-(p+1)}} \right) = 0$

and $\lim_{[X] \rightarrow \infty} \left(\frac{J_p'(\theta) R_2^p}{[X] R_2^p + R_2^{-(p+1)}} \right) = 0$

and $B_{p3} \Big|_{(\mu_1=\mu_2)} = 0$

The expression for A_{p1} is (see equation (38d) in the text)

$$A_{p1} = A_{p2} + B_{p2} R_1^{-(2p+1)} \quad (C-9)$$

The expression for A_{p1} when $\mu_1 = \mu_2$ is

$$A_{p1} \left| \begin{array}{c} \\ \\ \\ \end{array} \right|_{(\mu_1=\mu_2)} = A_{p2} \left| \begin{array}{c} \\ \\ \\ \end{array} \right|_{(\mu_1=\mu_2)} + \left[B_{p2} \left| \begin{array}{c} \\ \\ \\ \end{array} \right|_{(\mu_1=\mu_2)} \right] R_1^{-(2p+1)}$$

$$A_{p1} \left| \begin{array}{c} \\ \\ \\ \end{array} \right|_{(\mu_1=\mu_2)} = J_p'(\theta) \tag{C-10}$$

where

$$B_{p2} \left| \begin{array}{c} \\ \\ \\ \end{array} \right|_{(\mu_1=\mu_2)} = 0$$

The expression for B_{p4} (see equation (38e) in text) is:

$$B_{p4} = A_{p3} R_3^{(2p+1)} + B_{p3} \tag{C-11}$$

The expression for B_{p4} when $\mu_1 = \mu_2$ is

$$B_{p4} \left| \begin{array}{c} \\ \\ \\ \end{array} \right|_{(\mu_1=\mu_2)} = \left[A_{p3} \left| \begin{array}{c} \\ \\ \\ \end{array} \right|_{(\mu_1=\mu_2)} \right] R_3^{(2p+1)} + B_{p3} \left| \begin{array}{c} \\ \\ \\ \end{array} \right|_{(\mu_1=\mu_2)} \tag{C-12}$$

$$= \left[A_{p3} \left| \begin{array}{c} \\ \\ \\ \end{array} \right|_{(\mu_1=\mu_2)} \right] R_3^{(2p+1)} = \left[A_{p1} \left| \begin{array}{c} \\ \\ \\ \end{array} \right|_{(\mu_1=\mu_2)} \right] R_3^{(2p+1)}$$

where $B_{p3} \left| \begin{array}{c} \\ \\ \\ \end{array} \right|_{(\mu_1=\mu_2)} = 0$.

This means that in the four regions, the potentials used in equation (28) of the report are

$$A_{\psi I} = \sum_{p=1}^{\infty} (A_{p1} r^p) P_p^1(\cos\theta) \quad (C-13a)$$

$$A_{\psi II} = \sum_{p=1}^{\infty} \left(A_{p2} r^p + \frac{B_{p2}}{r^{(p+1)}} \right) P_p^1(\cos\theta) \quad (C-13b)$$

$$A_{\psi III} = \sum_{p=1}^{\infty} \left(A_{p3} r^p + \frac{B_{p3}}{r^{(p+1)}} \right) P_p^1(\cos\theta) \quad (C-13c)$$

$$A_{\psi IV} = \sum_{p=1}^{\infty} \left(\frac{B_{p4}}{r^{(p+1)}} \right) P_p^1(\cos\theta) \quad (C-13d)$$

reduce when $\mu_1 = \mu_2$ to the form

$$A_{\psi I, II, III} = \sum_{p=1}^{\infty} \left(\left[\begin{array}{c|c} A_{p1} & \\ \hline & (\mu_1 = \mu_2) \end{array} \right] r^p \right) P_p^1(\cos\theta) \quad (C-14a)$$

$$A_{\psi IV} = \sum_{p=1}^{\infty} \left(\frac{\left[\begin{array}{c|c} B_{p4} & \\ \hline & (\mu_1 = \mu_2) \end{array} \right]}{r^{(p+1)}} \right) P_p^1(\cos\theta) \quad (C-14b)$$

These are the solutions for the potentials of the current band in a region of space with homogeneous permeability μ_1 (see equations (B-1a and B-1b).

We now have the solutions for the two potentials in regions I and II

($A_{\psi I, II, III}$, and $A_{\psi IV}$, respectively) for the simple current band problem.

This indicates that the form of the coefficients A_{pi} and B_{pi} are mathematically correct.

The mathematical expressions for A_{p1} and B_{p4} will be evaluated in the limit as $\mu_1 = \mu_2$. These values will then be compared with the coefficients A_{p1} and B_{p2} , respectively, for the two regions of the current band problem (see Appendix B). B_{p4} (see equation (38e) in text) is:

$$B_{p4} = A_{p3} R_3^{(2p+1)} + B_{p3} \quad (C-15)$$

When $\mu_1 = \mu_2$, B_{p4} is:

$$B_{p4} \Big|_{(\mu_1=\mu_2)} = \left[A_{p3} \Big|_{(\mu_1=\mu_2)} \right] R_3^{(2p+1)} + B_{p3} \Big|_{(\mu_1=\mu_2)}$$

where

$$A_{p3} \Big|_{(\mu_1=\mu_2)} = J'_p(\theta)$$

and

$$B_{p3} \Big|_{(\mu_1=\mu_2)} = 0$$

$$B_{p4} \Big|_{(\mu_1=\mu_2)} = \mu_1 J_p(\theta) / P_p^1(\cos\theta) R_3^{-p-2(2p+1)} \quad (C-16)$$

The form of A_{p1} is:

$$A_{p1} \Big|_{(\mu_1=\mu_2)}$$

$$A_{p1} \Big|_{(\mu_1=\mu_2)} = \left[B_{p4} \Big|_{(\mu_1=\mu_2)} \right] R_3^{-2p-1} \quad (C-17)$$

The mathematical expressions for A_{p1} and B_{p4} (equations C-17 and C-16, respectively) for the ferromagnetic spherical shell surrounded by a thin current band in the limit as $\mu_1 = \mu_2$ are the same as the coefficients A_{p1} and B_{p2} (see equations B-4a and B-4b), respectively, for the vector potentials in the regions of the current band in free space (see Appendix B). It is noted that when making the comparison R_3 must be set equal to R_1 . For comparison, the coefficients for the current band problem are:

$$A_{p1} = B_{p2} R_1^{-2p-1} \quad (C-18a)$$

$$B_{p2} = \frac{\mu_1 J_p(\theta) / P_p^1(\cos\theta)}{R_1^{-p-2}(2p+1)} \quad (C-18b)$$

and the coefficients for the ferromagnetic shell problem with $\mu_1 = \mu_2$ are:

$$A_{p1} = B_{p4} R_3^{-2p-1} \quad (C-19a)$$

$$B_{p4} = \frac{\mu_1 J_p(\theta) / P_p^1(\cos\theta)}{R_3^{-p-2}(2p+1)} \quad (C-19b)$$

APPENDIX D

SOLUTION OF THE AZIMUTHAL COMPONENT OF THE VECTOR
 POISSON'S EQUATION $\nabla^2 A_\psi = -\mu J_\psi$ IN
 SPHERICAL COORDINATES

For the benefit of the reader, the azimuthal component (ψ component) of the vector Poisson's equation in spherical coordinates as originally derived by Purczyński⁹ is presented in detail as related to the problems addressed in this report. Because of the spherical symmetry of this problem, only the ψ component of the vector Poisson's equations is needed. Following in an outline of Purczyński's development, the general form of the component of the current is:

$$J_\psi(r, \theta) = Jr^{q-2} \sum_{p=1}^{\infty} K_p P_p^1(\cos\theta) \quad (D-1)$$

where the case $q = 2$ is of primary concern in this work. The general ψ component of Poisson's equation is written as

$$\nabla^2 A_\psi = \frac{\partial^2 A_\psi}{\partial r^2} + \frac{2}{r} \frac{\partial A_\psi}{\partial r} - \frac{A_\psi}{r^2 \sin^2 \theta} + \frac{1}{r^2} \frac{\partial^2 A_\psi}{\partial \theta^2} + \frac{\cot \theta}{r^2} \frac{\partial A_\psi}{\partial \theta} = \begin{cases} -\mu_2 J_\psi(r, \theta) & \text{in current region} \\ 0 & \text{otherwise} \end{cases} \quad (D-2)$$

Multiplying $\nabla^2 A_\psi$ by r^2 and substituting the general expression for $J_\psi(r, \theta)$ in equation (D-1) gives the expression

$$r^2 \frac{\partial^2 A_\psi}{\partial r^2} + 2r \frac{\partial A_\psi}{\partial r} - \frac{A_\psi}{\sin^2 \theta} + \frac{\partial^2 A_\psi}{\partial \theta^2} + \cot \theta \frac{\partial A_\psi}{\partial \theta} = -\mu_2 Jr^q \sum_{p=1}^{\infty} K_p P_p^1(\cos\theta) \quad (D-3)$$

which is assumed to have a solution of the form

$$A = A_{\psi} = \sum_{p=1}^{\infty} f(r) P_p^1(\cos\theta) \quad (D-4)$$

By separation of variables, equation (D-3) becomes:

$$\frac{d^2 \left[P_p^1(\cos\theta) \right]}{d\theta^2} + \frac{d \left[P_p^1(\cos\theta) \right]}{d\theta} \cot\theta +$$

$$\left[p(p+1) - \frac{1}{\sin^2\theta} \right] P_p^1(\cos\theta) = 0 \quad (D-5a)$$

$$r^2 \frac{d^2 f}{dr^2} + 2r \frac{df}{dr} - p(p+1)f = -\mu_2 J_r^q K_p \quad (D-5b)$$

where the separation constant $p(p+1)$ is an integer. Differential equations of the form

$$\frac{d^2 y}{dx^2} + p(x) \frac{dy}{dx} + Q(x)y = R(x) \quad (D-6)$$

have no general solution. The homogeneous part of equation (D-5b) has the form

$$r^2 \frac{d^2 f}{dr^2} + 2r \frac{df}{dr} - p(p+1)f = 0 \quad (D-7)$$

Equation (D-7) can be simplified by substituting $r = e^t$. Making the following substitutions in equation (D-7),

$$\frac{df}{dr} = \frac{df}{dt} \frac{dt}{dr} = \frac{df}{dt} \left(\frac{1}{r} \right) \quad (D-8)$$

$$\frac{d^2 f}{dr^2} = \frac{d^2 f}{dt^2} \left(\frac{dt}{dr} \right)^2 + \frac{df}{dt} \frac{d^2 t}{dr^2}$$

$$\frac{d^2 f}{dr^2} = \frac{d^2 f}{dt^2} \left(\frac{1}{r^2} \right) + \frac{df}{dt} \left(-\frac{1}{r^2} \right)$$

where $\frac{dt}{dr} = \frac{1}{r}$, $\frac{d^2 t}{dr^2} = -\frac{1}{r^2}$, (Note: $\ln(r) = t$)

yields

$$\frac{d^2 f}{dt^2} + \frac{df}{dt} - p(p+1)f = 0 \quad (D-9)$$

This has the well-known mathematical solution:

$$f_1 = A_p e^{pt} + B_p e^{-(p+1)t} \quad (D-10)$$

which after substitution of $r = e^t$ has the form

$$f_1 = A_p r^p + \frac{B_p}{r^{(p+1)}} \quad (D-11)$$

Thus the general mathematical solution to the homogeneous part of the azimuthal component of Poisson's equation is

$$A' = A'_\psi = \sum_{p=1}^{\infty} \left(A_p r^p + \frac{B_p}{r^{(p+1)}} \right) P_p^1(\cos\theta) \quad (D-12)$$

which is the solution to the azimuthal component of the vector Laplace's equation.

The solution to the inhomogeneous equation (D-5b) will now be investigated. It is assumed that the mathematical solution to equation (D-5b) has the general form

$$f_2 = d_p e^{qt} \quad (D-13)$$

for $p \neq q$. By algebraic manipulation after substituting into equation (D-5b) we have:

$$d_p = \frac{\mu_2 J K_p}{(p-q)(p+q+1)}, \quad (p \neq q) \quad (D-14)$$

If we assume that the mathematical solution to equation (D-5b) has the general form for $p = q$

$$f_2' = d_q t e^{qt} \quad (D-15)$$

It is found after substituting f_2' into equation (D-5b) that

$$d_q = \frac{-\mu_2 J K_q}{2q+1}, \quad (p=q) \quad (D-16)$$

Since A equals $\sum_{p=1}^{\infty} f(r) P_p^1(\cos\theta)$, the general mathematical solution to the inhomogeneous equation (D-5b) has the form

$$A'' = A_{\psi}'' = \mu_2 J r^q \left[\sum_{p \neq q}^{\infty} \frac{K_p P_p^1(\cos\theta)}{(p-q)(p+q+1)} - \frac{K_q P_q^1(\cos\theta) \ln(r)}{2q+1} \right] \quad (D-17)$$

The total general solution to equation (D-2) consists of the sum of the homogeneous and inhomogeneous equation.

$$A = A' + A'' = A_{\psi}' + A_{\psi}'' = \sum_{p=1}^{\infty} \left(A_p r^p + \frac{B_p}{r^{p+1}} \right) P_p^1(\cos\theta) \quad (D-18)$$

$$+ \mu_2 J r^q \left[\sum_{p \neq q}^{\infty} \frac{K_p P_p^1(\cos\theta)}{(p-q)(p+q+1)} - \frac{K_q P_q^1(\cos\theta) \ln(r)}{2q+1} \right]$$

For the problem worked in this report $q = 2$ and $K_p = 0$ for even p . Thus, K_2 is 0 and the term involving

$$-\mu_2 J r^2 \left[\frac{K_2 P_2^1(\cos\theta) \ln(r)}{5} \right]$$

in equation (D-18) does not contribute. In this case (D-18) reduces to (see equation (53c) in text of report where $A_p = A_{p3}$ and $B_p = B_{p3}$).

$$\begin{aligned}
 A_{III} = A_{\psi III} &= \sum_{p=1}^{\infty} \left[A_p r^p + \frac{B_p}{r^{p+1}} \right] P_p^1(\cos\theta) \\
 + \mu_2 J r^2 \sum_{\substack{p \neq 2 \\ p=1}}^{\infty} &\frac{K P_p^1(\cos\theta)}{(p-2)(p+3)}
 \end{aligned}
 \tag{D-19}$$

APPENDIX E

CALCULATION OF COEFFICIENTS OF THE VECTOR
POTENTIAL FOR A SOLID FERROMAGNETIC
SPHERE SURROUNDED BY A COIL
OF FINITE WIDTH

In this appendix we derive the coefficients for the magnetic vector potentials in regions I-IV for a solid ferromagnetic sphere surrounded by a finite width current band. For a detailed discussion of the ferromagnetic problem see the section in the text of the report entitled "Ferromagnetic Sphere Surrounded by Coil of Finite Width". The vector potentials in each region are:

$$A_I = A_{\psi I} = \sum_{p=1}^{\infty} (A_{p1} r^p) P_p^1(\cos\theta) \quad (E-1a)$$

$$A_{II} = A_{\psi II} = \sum_{p=1}^{\infty} \left(A_{p2} r^p + \frac{B_{p2}}{r^{(p+1)}} \right) P_p^1(\cos\theta) \quad (E-1b)$$

$$A_{III} = A_{\psi III} = \sum_{p=1}^{\infty} \left(A_{p3} r^p + \frac{B_{p3}}{r^{(p+1)}} \right) P_p^1(\cos\theta) \\ + \sum_{\substack{p \neq 2 \\ p=1}}^{\infty} \left(\frac{\mu_2 J K_p r^2}{(p-2)(p+3)} \right) P_p^1(\cos\theta) \quad (E-1c)$$

$$A_{IV} = A_{\psi IV} = \sum_{p=1}^{\infty} \left(\frac{B_{p4}}{r^{(p+1)}} \right) P_p^1(\cos\theta) \quad (E-1d)$$

The coefficients (A_{pi} and B_{pi}) in equations (E-1a to E-1d) are obtained by substituting these equations into the boundary conditions (equations E-2a to E-2f).

$$A_I = A_{II} \text{ at } r = R_1 \quad (E-2a)$$

$$A_{II} = A_{III} \text{ at } r = R_2 \quad (E-2b)$$

$$A_{III} = A_{IV} \text{ at } r = R_3 \quad (E-2c)$$

$$\frac{1}{\mu_2} \frac{1}{r} \frac{\partial}{\partial r} (rA_{II}) = \frac{1}{\mu_1} \frac{1}{r} \frac{\partial}{\partial r} (rA_I) \text{ at } r = R_1 \quad (E-2d)$$

$$\frac{1}{\mu_2} \frac{1}{r} \frac{\partial}{\partial r} (rA_{III}) = \frac{1}{\mu_2} \frac{1}{r} \frac{\partial}{\partial r} (rA_{II}) \text{ at } r = R_2 \quad (E-2e)$$

$$\frac{1}{\mu_2} \frac{1}{r} \frac{\partial}{\partial r} (rA_{IV}) = \frac{1}{\mu_2} \frac{1}{r} \frac{\partial}{\partial r} (rA_{III}) \text{ at } r = R_3 \quad (E-2f)$$

After appropriate substitutions of equations (E-1a to E-1d) into equations (E-2a to E-2f) the following boundary value equations are obtained.

$$A_{p1} R_1^p = A_{p2} R_1^p + \frac{B_{p2}}{R_1^{(p+1)}} \quad (E-3a)$$

$$A_{p2} R_2^p + B_{p2} R_2^{-(p+1)} = A_{p3} R_2^p + B_{p3} R_2^{-(p+1)} + \left(\mu_2 J R_2^2 K_p / (p-2)(p+3) \right) \quad (E-3b)$$

$$A_{p3} R_3^p + B_{p3} R_3^{-(p+1)} + \frac{\mu_2 J R_3^2 K_p}{(p-2)(p+3)} = B_{p4} R_3^{-(p+1)} \quad (E-3c)$$

$$\frac{1}{\mu_2} \left[A_{p2} (p+1) R_1^{(p-1)} - (p) B_{p2} R_1^{-(p+2)} \right] = \frac{1}{\mu_1} A_{p1} (p+1) R_1^{(p-1)} \quad (E-3d)$$

$$\frac{1}{\mu_2} \left[A_{p3}^{(p+1)} R_2^{(p-1)} - (p) B_{p3} R_2^{-(p+2)} + \frac{3\mu_2 J R_2 K_p}{(p-2)(p+3)} \right] = \quad (E-3e)$$

$$\frac{1}{\mu_2} \left[A_{p2}^{(p+1)} R_2^{(p-1)} - (p) B_{p2} R_2^{-(p+2)} \right]$$

$$\frac{1}{\mu_2} \left[- (p) B_{p4} R_3^{-(p+2)} \right] = \frac{1}{\mu_2} \left\{ A_{p3}^{(p+1)} R_3^{p-1} - (p) B_{p3} R_3^{-(p+2)} \right. \quad (E-3f)$$

$$\left. + \left(3 \mu_2 J R_3 K_p / (p-2)(p+3) \right) \right\}$$

These algebraic equations provide six simultaneous equations with six unknowns, and can be solved for the coefficients (A_{pi} and B_{pi}) by algebraic manipulation.

Solving algebraically equations (E-3a) and (E-3d) results in the following solution for A_{p2} in terms of B_{p2} .

$$A_{p2} = [X] B_{p2} \quad (E-4)$$

$$\text{where } [X] = -R_1^{-(2p+1)} \left[1 + \left(\frac{p}{p+1} \right) \frac{\mu_1}{\mu_2} \right] / \left(1 - \frac{\mu_1}{\mu_2} \right)$$

The solution for A_{p1} from equation (E-3a) is:

$$A_{p1} = A_{p2} + B_{p2} R_1^{-(2p+1)} \quad (E-5)$$

Also, solving equation (E-3c) and (E-3f) algebraically for mathematical expressions describing B_{p4} gives the expression for A_{p3} in terms of B_{p3} and known quantities after equating the functions for $B_{p4} = B_{p4}$ from each equation.

$$A_{p3} = K'_p \quad (E-6)$$

$$K'_p = - \frac{\mu_2 J K_p R_3^{-p+2}}{(p-2)(2p+1)}$$

The algebraic solution of B_{p4} from equation (E-3c) is:

$$B_{p4} = A_{p3} R_3^{(2p+1)} + B_{p3} + \frac{\mu_2 J R_3^{(p+3)} K_p}{(p-2)(p+3)} \quad (E-7)$$

The following expression is obtained for B_{p2} from equation (E-3b) after substituting the expressions for A_{p3} (equation E-6) and A_{p2} (equation E-4).

$$B_{p2} = B_{p3} [Z] + K''_p \quad (E-8)$$

$$\text{where } [Z] = \frac{R_2^{-(p+1)}}{([X] R_2^p + R_2^{-(p+1)})}$$

$$K''_p = \frac{\frac{K'_p R_2^p}{(p-2)(p+3)} + \frac{\mu_2 J R_2^2 K_p}{(p-2)(p+3)}}{([X] R_2^p + R_2^{-(p+1)})}$$

The mathematical solution for B_{p3} in terms of known quantities is obtained from equation (E-3e), by substituting the previously obtained expressions for A_{p3} (equation E-6), A_{p2} (equation E-4), and B_{p2} (equation E-8).

$$B_{p3} = \left\{ -K'_p \left[(p+1)R_2^{(p-1)} \right] - \frac{3\mu_2 J R_2^2 K_p}{(p-2)(p+3)} \right. \quad (E-9a)$$

$$\left. + [X] (p+1)R_2^{(p-1)} K''_p - (p)R_2^{-(p+2)} K''_p \right\} /$$

$$\left\{ (-p)R_2^{-(p+2)} - [Z] [X] (p+1)R_2^{p-1} + (p)R_2^{-(p+2)} [Z] \right\}$$

where

$$[X] = \frac{-R_1^{-(2p+1)} \left[1 + \left(\frac{p}{p+1} \right) \frac{\mu_1}{\mu_2} \right]}{\left(1 - \frac{\mu_1}{\mu_2} \right)} \quad (E-9b)$$

$$K'_p = - \frac{\mu_2 J K_p R_3^{-p+2}}{(p-2)(2p+1)} \quad (E-9c)$$

$$[Z] = \frac{R_2^{-(p+1)}}{\left([X] R_2^p + R_2^{-(p+1)} \right)} \quad (E-9d)$$

$$K''_p = \frac{\frac{\mu_2 J R_2^2 K_p}{(p-2)(p+3)} + K'_p R_2^p}{\left([X] R_2^p + R_2^{-(p+1)} \right)} \quad (E-9e)$$

After a numerical value for B_{p3} is calculated on the computer for a specific problem the numerical values for the other coefficients can be obtained from the following equations.

$$B_{p2} = B_{p3} [Z] + K''_p, \quad (\text{see equation E-8}) \quad (E-10a)$$

$$A_{p3} = K_p' \quad (\text{see equation E-6}) \quad (\text{E-10b})$$

$$A_{p2} = [X] B_{p2} \quad (\text{see equation E-4}) \quad (\text{E-10c})$$

$$A_{p1} = A_{p2} + B_{p2} R_1^{-(2p+1)} \quad (\text{see equation E-5}) \quad (\text{E-10d})$$

$$B_{p4} = A_{p3} R_3^{(2p+1)} + B_{p3} + \frac{\mu_2 J R_3^{(p+3)} K_p}{(p-2)(p+3)} \quad (\text{see equation E-7}) \quad (\text{E-10e})$$

REFERENCES

1. Sarma, M. S., "Magnetostatic Field Computation by Finite Element Formulation," IEEE Transactions on Magnetics, Vol. MAG-12, pp. 1050-1052 (Nov 1976)
2. Donea, J., et al, "Finite Element in the Solution of Electromagnetic Induction Problems," International Journal for Numerical Methods in Engineering, Vol. 8, pp. 359-367 (1974)
3. McDonald, J. R., et al, "A Mathematical Model for Calculating Electrical Conditions in Wire-Duct Electrostatic Precipitation Devices;" Journal of Applied Physics, Vol. 48, pp. 2231-2243 (June 1977)
4. Zienkiewicz, O. C., et al, "Three-Dimensional Magnetic Field Determination Using a Scalar Potential - A Finite Element Solution," IEEE Transactions on Magnetics, Vol. MAG-13, pp. 1649-1656 (Sep 1977)
5. Holzinger, C. S., "Computation of Magnetic Fields Within Three-Dimensional Highly Nonlinear Media," IEEE Transactions on Magnetics, Vol. MAG-6, pp. 60-65, (Mar 1970)
6. Demerdash, N. A. and T. W. Nehl, "Flexibility and Economics of Implementation of the Finite Element and Difference Techniques in Non-linear Magnetic Fields of Power Devices," IEEE Transactions on Magnetics, Vol. MAG-12, pp. 1036-1038 (Nov 1976)
7. Nixon, D. A., et al, "The Iron Body Computer Program to Calculate the Magnetic Field of Ferromagnetic Bodies," NSRDC Rept 3567 (May 1972)
8. Nixon, D. A., and J. R. Fleming, "Degaussing Program 5 Revised," NSRDC Rept 27-23 (Mar 1972)
9. Purczynski, J., "Pole Magnetyczne Silnika Elektrycznego o Trzech Stopniach Swobody," Archiwum Elektrotechniki, Tom XXIII, z.2, pp. 455-467 (1974)
10. Jackson, J. D., Classical Electrodynamics, 6th Printing, John Wiley & Sons, Inc., NY (1967)
11. Smythe, W. R., Static and Dynamic Electricity, 3rd Ed., McGraw-Hill Book Co., Inc., NY (1968)

INITIAL DISTRIBUTION

Copies

- 1 NRL (Code 5294, Mr. R. Clement)
- 5 NAVSEA
 - 1 SEA 03
 - 1 SEA 03424 (Mr. W. Welsh)
 - 2 SEA 09G32
 - 1 PM-2001 (Mr. J. Crone)
- 2 NUSC/NL
 - 1 Code 401 (Mr. J. Frye)
 - 1 Code 401 (Dr. R. Kasper)
- 1 NCSC (Code 792)
 - Attn: Dr. W. Michael Wynn
- 3 NSWC/WOL
 - 1 Code E22 (Mr. K. Bishop)
 - 1 Code R43 (Mr. M. Kraichman)
 - 1 Code E22 (Dr. J. Holmes)
- 1 Science Applications, Inc.
 - Attn: Dr. J. Czika
- 2 Vanderbilt University
 - Attn: Dr. J. Wikswo, Jr.
- 2 University of Pennsylvania
 - Attn: Dr. R. Showers
- 1 Stanford Electronics Laboratory
 - Stanford University
 - Attn: Dr. A. C. Fraser-Smith
- 2 Naval Postgraduate School
 - Code 023 (Dr. R. Fossum)
- 12 DDC

CENTER DISTRIBUTION

- | Copies | Code |
|--------|------------------------|
| 10 | (2704) |
| 5 | (2731, S. H. Brown) |
| 5 | (2732, F.E. Baker) |
| 5 | (2733, P.T. Field) |
| 1 | (2782, W. J. Andahazy) |
| 1 | (2782, F.B. Walker) |
| 1 | (2782, B.R. Hood) |
| 1 | (2782, D.A. Nixon) |
| 1 | (522.1) |
| 2 | (5231) |
| 2 | (273) |

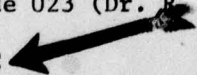

DTNSRDC ISSUES THREE TYPES OF REPORTS

1. DTNSRDC REPORTS, A FORMAL SERIES, CONTAIN INFORMATION OF PERMANENT TECHNICAL VALUE. THEY CARRY A CONSECUTIVE NUMERICAL IDENTIFICATION REGARDLESS OF THEIR CLASSIFICATION OR THE ORIGINATING DEPARTMENT.

2. DEPARTMENTAL REPORTS, A SEMIFORMAL SERIES, CONTAIN INFORMATION OF A PRELIMINARY, TEMPORARY, OR PROPRIETARY NATURE OR OF LIMITED INTEREST OR SIGNIFICANCE. THEY CARRY A DEPARTMENTAL ALPHANUMERICAL IDENTIFICATION.

3. TECHNICAL MEMORANDA, AN INFORMAL SERIES, CONTAIN TECHNICAL DOCUMENTATION OF LIMITED USE AND INTEREST. THEY ARE PRIMARILY WORKING PAPERS INTENDED FOR INTERNAL USE. THEY CARRY AN IDENTIFYING NUMBER WHICH INDICATES THEIR TYPE AND THE NUMERICAL CODE OF THE ORIGINATING DEPARTMENT. ANY DISTRIBUTION OUTSIDE DTNSRDC MUST BE APPROVED BY THE HEAD OF THE ORIGINATING DEPARTMENT ON A CASE-BY-CASE BASIS.

AD-A065 809

DAVID W TAYLOR NAVAL SHIP RESEARCH AND DEVELOPMENT CE--ETC F/G 20/3
THE MAGNETIC INDUCTION OF THE SYSTEM CONSISTING OF A COIL AND A--ETC(U)
MAR 79 S H BROWN, F E BAKER

UNCLASSIFIED

DTNSRDC/PAS-78-35

NL

2 OF 2
AD
A065809

SUPPLEMENTARY
INFORMATION



END
DATE
FILMED
10-79
DDC

SUPPLEMENTARY

INFORMATION



DAVID W. TAYLOR NAVAL SHIP RESEARCH
AND DEVELOPMENT CENTER

HEADQUARTERS
BETHESDA, MARYLAND 20084

ANNAPOLIS LABORATORY
ANNAPOLIS, MD 21402
CARDEROCK LABORATORY
BETHESDA, MD 20084

IN REPLY REFER TO:
2704:FEB
9590

14 SEP 1979

From: Commander, David W. Taylor Naval Ship R&D Center
To: Distribution List

Subj: Rept DTNSRDC/PAS-78-35 of March 1979 entitled "The Magnetic
Induction of the System Consisting of a Coil and a Ferromagnetic
Spherical Body", changes to

Encl: (1) Changes to DTNSRDC/PAS-78-35

1. Enclosure (1) is forwarded herewith as replacements for pages 19,
37, 38, and 39 of subject report.

W. J. ANDAHAZY
By direction

Copy to:

NRL (Code 5294, Mr. R. Clement)
NAVSEA (SEA 03)
NAVSEA (SEA 09G32) (2)
NUSC/NL (Code 401, Mr. J. Frye and Dr. R. Kasper)
NCSC (Code 792, Dr. W. Michael Wynn)
NSWC/WO (Code E 22, Mr. K. Bishop)
NSWC/WO (Code R 43, Mr. M. Kraichman)
NSWC/WO (Code E 22, Dr. J. Holmes)
Science Applications, Inc. (Dr. J. Czika)
Vanderbilt University (Dr. J. Wikswow, Jr.)
University of Pennsylvania (Dr. R. Showers)
Stanford Electronics Laboratory
Stanford University (Dr. A. C. Fraser-Smith)
Naval Postgraduate School (Code 023, Dr. R. R. Fossum)
DDC (12)

AD-A065-809

The identity

$$\int_0^\pi P_{p'}^{m'}(\cos\theta) P_p^m(\cos\theta) \sin\theta d\theta = \frac{2(p+m)!}{(2p+1)(p-m)!} \delta_{p'p} \quad (43)$$

was used to determine K_p (equation 42). Setting $J_\psi(\theta)$ to a constant J we can express equation (42) as:

$$K_p = \frac{2p+1}{2p(p+1)} \int_0^\pi P_p^1(\cos\theta) \sin\theta d\theta \quad (44)$$

Since the current in this problem extends from $(\frac{\pi}{2} - \alpha)$ to $(\frac{\pi}{2} + \alpha)$, see Figure 4, the expression for K_p (equation 44) may be written as

$$K_p = \frac{2p+1}{2p(p+1)} \left[\int_{\frac{\pi}{2} - \alpha}^{\frac{\pi}{2}} P_p^1(\cos\theta) \sin\theta d\theta + \int_{\frac{\pi}{2}}^{\frac{\pi}{2} + \alpha} P_p^1(\cos\theta) \sin\theta d\theta \right] \quad (45)$$

By noting that

$$P_p^1(-\cos\theta) = (-1)^{p-1} P_p^1(\cos\theta) \quad (46)$$

it follows that the associated Legendre functions $P_p^1(\cos\theta)$ are even functions with respect to $\cos\theta$ when p is odd. The expression for K_p may be simplified to

$$K_p = \frac{2p+1}{p(p+1)} \int_{\frac{\pi}{2} - \alpha}^{\frac{\pi}{2}} P_p^1(\cos\theta) \sin\theta d\theta \quad (47)$$

when p is odd ($K_p = 0$ when p is even) after utilizing the symmetry of $J(\theta)$ in Figure 5. By changing the variable in equation (47) to $\mu' = \cos\theta$, the integral for K_p may be written as

$$K_p = \frac{2p+1}{p(p+1)} \int_0^{\sin\alpha} P_p^1(\mu') d\mu' \quad (48)$$

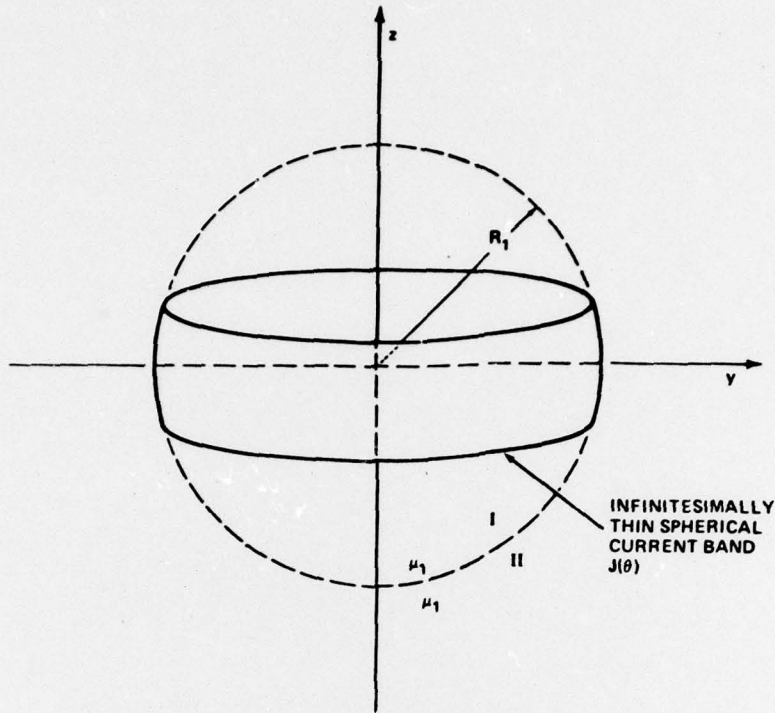

Figure 1-B - Infinitesimally Thin Current Band

Now the solution for $A_{\psi II}$ (equation B-5b) can be reduced to that for the filamentary coil and the answer compared with that for the same problem from a standard text (Jackson,¹⁰ page 144, equation (5.46)).

The coefficient JK_p for the expansion of the current

$$J_{\psi}(\theta) = \sum_p JK_p P_p^1(\cos \theta) \quad (B-6)$$

for the current filament is obtained from the equation (see equation B-5d):

$$\begin{aligned}
 JK_p &= - \frac{2p+1}{2p(p+1)} \int_{\cos(0)}^{\cos(\pi)} \frac{I}{R_1} \delta(\cos \theta) P_p^1(\cos \theta) d(\cos \theta) \quad (B-7) \\
 &= \frac{I}{R_1} \left(\frac{2p+1}{2p(p+1)} \right) P_p^1(0)
 \end{aligned}$$

$$JK_p = \left[\frac{(2p+1)}{2p(p+1)} \right] \left[\frac{I}{R_1} P_p^1(0) \right]$$

where $J(\theta) = \frac{I}{R_1} \delta(\cos\theta)$

The special value of the associated Legendre function is calculated from the expression (where $m = 1$)

$$P_p^m(0) = \begin{cases} \frac{(-1)^{(p-m)/2} (p+m)!}{2^p \left(\frac{p-m}{2}\right)! \left(\frac{p+m}{2}\right)!}, & (p+m, \text{ even}) \\ = 0 & (p+m, \text{ odd}) \end{cases} \quad (\text{B-8})$$

This expression may be derived from the series expansion for the Legendre function (see Smythe)¹¹ and letting $\cos\theta = \mu'$ approach 0.

Substituting the expression for JK_p (equation B-7), into equation (B-5b) results in the expression for the vector potentials $A_{\psi II}$ in the external region for the filamentary coil.

$$A_{\psi II} = \sum_{p=1}^{\infty} \frac{\mu_1 I P_p^1(\cos\theta)}{(2p)(p+1)} \left(\frac{R_1}{r}\right)^{p+1} P_p^1(0) \quad (\text{B-9a})$$

Now equation (B-9a) must be multiplied by $\frac{4\pi}{c}$ to change from SI units to Gaussian units, and μ_1 must be set equal to 1 as μ_1 is the free space permeability which equals 1 in the Gaussian system.

After making these substitutions we have

$$A_{\psi II} = \frac{4\pi}{c} \sum_{p=1}^{\infty} \frac{I P_p^1(\cos\theta)}{2p(p+1)} \left(\frac{R_1}{r}\right)^{p+1} P_p^1(0) \quad (\text{B-9b})$$

Now taking the first term ($p=1$) for use in the comparison with the result in Jackson¹⁰ we have

$$A_{\psi II} \Big|_{(p=1)} = \frac{I\pi}{c} \left(\frac{R_1}{r} \right)^2 P_1^1(\cos\theta) \quad (\text{B-9c})$$

Equation (B-9c) agrees exactly with the first term in the series by Jackson,¹⁰ where $R_1 = a$ in his notation, except for a minus sign. When the (-1) phase factor in the definition of the Associated Legendre functions $P_1^1(\cos\theta)$ is taken into account, the two expressions are the same. The general expressions for the Associated Legendre functions $P_p^m(\cos\theta)$ in this work do not contain the $(-1)^m$ phase factor used by Jackson.

The $A_{\psi I} \Big|_{(p=1)}$ term for the current band problem also reduces exactly to Jackson's term for $n=0$ (Jackson,¹⁰ page 144, equation 5.46) for the potential inside the loop when the (-1) phase factor is again taken into account.