

AD-A065 521

VOUGHT CORP ADVANCED TECHNOLOGY CENTER INC DALLAS TEX F/G 11/1
STRUCTURAL PROPERTIES OF ADHESIVES. VOLUME II. APPENDICES. A. T--ETC(U)
SEP 78 W J RENTON F33615-76-C-5205

UNCLASSIFIED

ATC-2-53500/8CRL-96

AFML-TR-78-127-VOL-2-APP-A NL

1 of 2

AD
AO 856.21

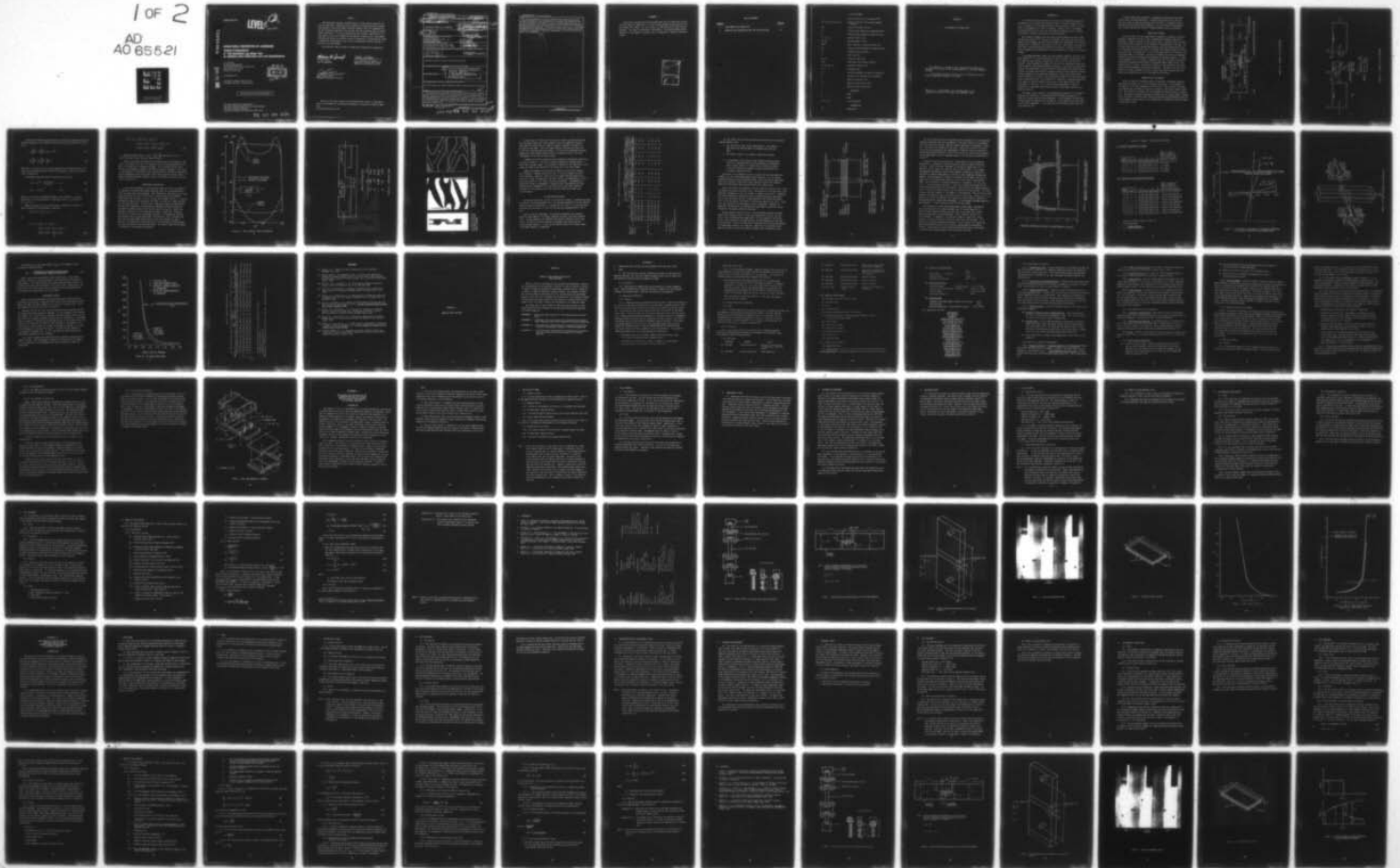

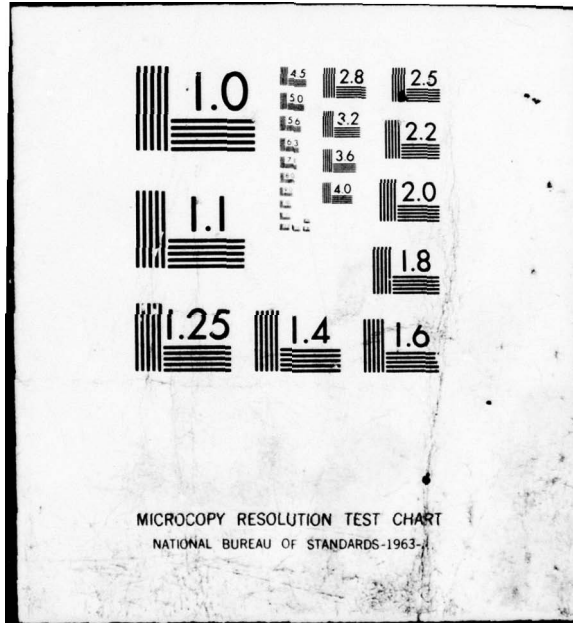

AFML-TR-78-127

LEVEL

②
SC
A065500

AD A0 65521

STRUCTURAL PROPERTIES OF ADHESIVES

Volume II Appendices

A- The Symmetric Lap Shear Test

B- Adhesive Joint Fabrication and Test Specifications

W. J. RENTON
VOUGHT CORPORATION
ADVANCED TECHNOLOGY CENTER, INC.
POST OFFICE BOX 226144
DALLAS, TEXAS 75266

SEPTEMBER 1978

TECHNICAL REPORT AFML-TR-78-127
Final Report April 1976 - September 1978

DDC
RECEIVED
MAR 9 1979
REGULATED

DDC FILE COPY

Approved for public release; distribution unlimited.

AIR FORCE MATERIALS LABORATORY
AIR FORCE WRIGHT AERONAUTICAL LABORATORIES
AIR FORCE SYSTEMS COMMAND
WRIGHT-PATTERSON AIR FORCE BASE, OHIO 45433

79 03 06 020

NOTICE

When Government drawings, specifications, or other data are used for any purpose other than in connection with a definitely related Government procurement operation, the United States Government thereby incurs no responsibility nor any obligation whatsoever; and the fact that the government may have formulated, furnished, or in any way supplied the said drawings, specifications, or other data, is not to be regarded by implication or otherwise as in any manner licensing the holder or any other person or corporation, or conveying any rights or permission to manufacture, use, or sell any patented invention that may in any way be related thereto.

This technical report has been reviewed and is approved for publication.

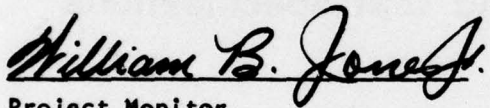

Project Monitor
FOR THE COMMANDER

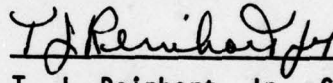

T. J. Reinhart, Jr., Chief
Composite & Fibrous Mats Branch
Nonmetallic Materials Division

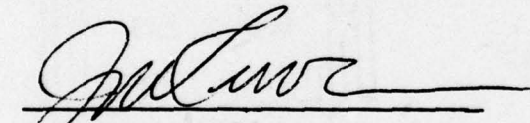

J. M. Kelble, Chief
Nonmetallic Materials Division

Copies of this report should not be returned unless return is required by security considerations, contractual obligations, or notice on a specific document.

Unclassified

SECURITY CLASSIFICATION OF THIS PAGE (When Data Entered)

19 REPORT DOCUMENTATION PAGE		READ INSTRUCTIONS BEFORE COMPLETING FORM
1. REPORT NUMBER 18 AFML TR-78-127-VOL 2-2	2. GOVT ACCESSION NO.	3. RECIPIENT'S CATALOG NUMBER 9
4. TITLE (and Subtitle) STRUCTURAL PROPERTIES OF ADHESIVES	5. TYPE OF REPORT & PERIOD COVERED 14 Technical Final <i>Technical rept.</i> Apr 1976 - September 1978 ATC-2-53500/8CRL-96	6. AUTHORING OR REPORT NUMBER 2
7. AUTHOR(s) 10 W. J. RENTON	8. CONTRACT OR GRANT NUMBER(s) 15 F33615-76-C-5205	
9. PERFORMING ORGANIZATION NAME AND ADDRESS Vought Corporation Advanced Technology Center, Inc. P. O. Box 226144 Dallas, Texas 75266	10. PROGRAM ELEMENT, PROJECT, TASK AREA & WORK UNIT NUMBERS 16 7340-02-24 17	
11. CONTROLLING OFFICE NAME AND ADDRESS Air Force Materials Laboratory (MBC) Wright-Patterson AF Base, Ohio 45433	12. REPORT DATE 11 September 1978	13. NUMBER OF PAGES 117
14. MONITORING AGENCY NAME & ADDRESS (if different from Controlling Office) 12 124p.	15. SECURITY CLASS. (of this report) Unclassified	15a. DECLASSIFICATION/DOWNGRADING SCHEDULE
16. DISTRIBUTION STATEMENT (of this Report) Approved for public release; distribution unlimited		
17. DISTRIBUTION STATEMENT (of the abstract entered in Block 20, if different from Report) 6 Structural Properties of Adhesives. Volume II. Appendices. A. The Symmetric Lap Shear Test. B. Adhesive Joint Fabrication and Test Specifications.		
18. SUPPLEMENTARY NOTES		
19. KEY WORDS (Continue on reverse side if necessary and identify by block number) Structural Adhesives, Adhesive Bonding, Adhesive Mechanical Characterization		
20. ABSTRACT (Continue on reverse side if necessary and identify by block number) To enable primary structures to be adhesively bonded in future aerospace hardware structural response prediction procedures must be improved upon. One task in accomplishing this overall objective is a requirement that a set of standardized adhesive test specifications be formulated. It was the objective of this "Structural Properties of Adhesives" program to develop low cost adhesive test procedures required to generate the required rigorous engineering structural property data.		

DD FORM 1 JAN 73 1473

EDITION OF 1 NOV 65 IS OBSOLETE
S/N 0102-014-6601

Unclassified
SECURITY CLASSIFICATION OF THIS PAGE (When Data Entered)

389 797 79 03 06 020

~~Unclassified~~
SECURITY CLASSIFICATION OF THIS PAGE(When Data Entered)

The desired engineering structural properties were specified as was their accuracy requirements. Optimum adhesive test specimens were designed as was a new adhesive deformation measurement system; a parallel plate capacitor. An extensive review of the literature on adhesive testing enabled the formulation of ASTM type adhesive test specifications for static, viscoelastic, and fatigue characterization of adhesives. A fabrication specification was also formulated. Selected test data were generated to verify that the test procedures were easy to perform and repeatable. Additional improvements in the butt joint test procedure were recommended.

UNCLASSIFIED
SECURITY CLASSIFICATION OF THIS PAGE(When Data Entered)

FOREWORD

The efforts reported herein were accomplished with the sponsorship of the Air Force Materials Laboratory, Air Force Systems Command, Wright-Patterson Air Force Base, Ohio, 45433. Dr. W. B. Jones, Jr., MBC, was the Air Force Project Engineer. The report is published in two volumes. The second volume contains Appendix A, "The Symmetric Lap Shear Test" and Appendix B, "Adhesive Specifications".

ACCESSION NO.	
NTIS	White Section <input checked="" type="checkbox"/>
DDC	Buff Section <input type="checkbox"/>
UNANNOUNCED	<input type="checkbox"/>
JUSTIFICATION	
BY	
DISTRIBUTION/AVAILABILITY CODES	
Dist.	Avail. / SPECIAL
A	

TABLE OF CONTENTS

<u>APPENDIX</u>		<u>PAGE NO.</u>
A	THE SYMMETRIC LAP SHEAR TEST	1
B	ADHESIVE JOINT FABRICATION AND TEST SPECIFICATIONS	24

LIST OF SYMBOLS

A	Cross sectional area of adherend (in ²)
$\Lambda_1, \Lambda_2, \Lambda_3, B_4, B_5, B_6$	Materials property and specimen geometry constants
D_{11}	Flexural stiffness (in-lb)
E	Primary Young's modulus of adherends (psi)
G	Effective shear modulus of adhesive (psi)
L_1, L_2, L_4	Specimen lengths (in)
M_1, M_4	Bending moment (in-lb)
$N(x)_i^T$	Axial load due to thermal effects (lb)
Q_{11}	Primary stiffness modulus of adherend (psi)
S_i	Boundary value constants
T	Axial load (lb)
V_1, V_4	Transverse shear (lb)
$g(x)$	Temperature distribution function
h_1, h_2, h_3, h_4	Specimen thickness (in)
x, z	Orthogonal axes
β_i	Constants dependent on material properties
λ_i	Eigenvalues of characteristic equations
n	Adhesive thickness (in)
σ_o	Adhesive normal stress (psi)
τ	Adhesive shear stress (psi)

SUBSCRIPTS

L	Upper
u	Lower
1, 2, 3, 4	Part designation

SUPERSCRIPTS

"T"	Temperature
-----	-------------

APPENDIX A

THE SYMMETRIC LAP SHEAR TEST*

This appendix is included in order to present the analysis and rationale for selection of the optimum geometry for the thick adherend specimen.

It also details possible sources of error introduced by various adhesive deformation systems in use today.

*Renton, W. J., "The Symmetric Lap Joint-What Good Is It?", *Experimental Mechanics*, Vol. 16, p. 409, November, 1976.

INTRODUCTION

It has been the usual practice to utilize the bulk mechanical properties of adhesives in the analysis and design of metal or non-metal bonded joints. This is erroneous, as the adhesive system in most structural joints is of the order of thousandths of an inch in thickness. Zabora, et al.,¹ and Hughes and Rutherford² point out that thin film adhesive properties are, in general significantly different than those of the bulk adhesive.

Most recently a Napkin-ring test piece has been employed to obtain shear and tensile properties.²⁻⁶ The use of the Napkin-ring test piece can provide adhesive shear property data for typical bonded joint thicknesses, but requires extreme care in loading to insure only pure torque. Additionally, the cost per test item is quite high and the specimen configuration is notably different from the geometrical configuration in which the adhesive is used as a structural element.

An alternate approach, namely the thick adherend symmetric lap joint, has been proposed⁷⁻¹⁰ as a viable specimen with which to obtain the effective thin film adhesive shear modulus, proportional limit stress and ultimate shear strength. Obtaining adhesive properties from this test specimen provides data readily usable in the numerous methods of analysis in use today for determining stresses and deformations in both the adhesive and adherends of bonded joints. Further, the trends associated with cogent variables such as adhesive thickness, surface roughness, ply orientation, temperature, strain rate, and residual strains effected by curing for various adhesive systems can be obtained through these standardized tests. Ply orientation is important in laminated adherends as an angle ply lamina frequently fails prior to the adhesive due to the brittleness of the resin. As a result accurate measurement of adhesive deformation is impossible unless one can attach a measurement device at the adhesive bondline.

This paper looks in depth at the proposed shear specimen in an attempt to determine its usefulness in obtaining the desired adhesive properties. In doing this several questions were addressed. Is the specimen a reliable and accurate means of characterizing the behavior of the adhesive when restrained by two "rigid" adherends? If so, what are the constraints within which the test should be run?

To answer these basic questions, a comprehensive theoretical and experimental effort has been formulated. A closed form analysis of the joint, a series of tests to check the accuracy of the analysis, a parametric study to determine the optimum specimen parameters, a critical review of the measurement systems used and the results of several adhesive tests are presented.

ANALYTICAL APPROACH

To gain insight into the linear-elastic response of a symmetric lap joint specimen, subjected to an axial load, a comprehensive method of analysis is presented. General relations for the stress couple, transverse shear resultant and in-plane stress resultant at any location in the adherends is derived. Use of these relations and the appropriate boundary conditions enables one to predict accurately the state of stress in both the joint adhesive material as well as at any point in the adherends. A full-field experimental verification of the analytical model is also shown. The analysis assumes the joint to be composed of generally orthotropic adherends secured with an isotropic adhesive. A plane strain approach (i.e., the panel is assumed to be infinitely wide in the width direction) incorporating the effects of transverse shear, normal strain, and thermal effects is taken. The analysis consists of the solution of two fourth order ordinary homogeneous differential equations. The state of stress in the adhesive is shown to generally consist of shear and normal stresses with the shear stress becoming zero at the free edges of the overlap.

FORMULATION OF THE PROBLEM

Given two identical rectangular panels of generally orthotropic material; each sheet has length $(L_1 + L_2)$ and thickness $(h_1$ and $h_2)$. The thickness of the adhesive (η) is small compared to (h_1) and (h_2) . The far ends of the sheet are supported and are loaded in tens on by a force of (T) lbs/unit width, Figure A-1a. The structure is divided into four elements for ease of analysis, Figure A-1b. The theory to develop the general relations for the stress couple, in-plane stress resultant, transverse shear resultant and governing differential equations for the adhesive shear stress is quite lengthy and is presented in explicit detail in References 7 and 8.

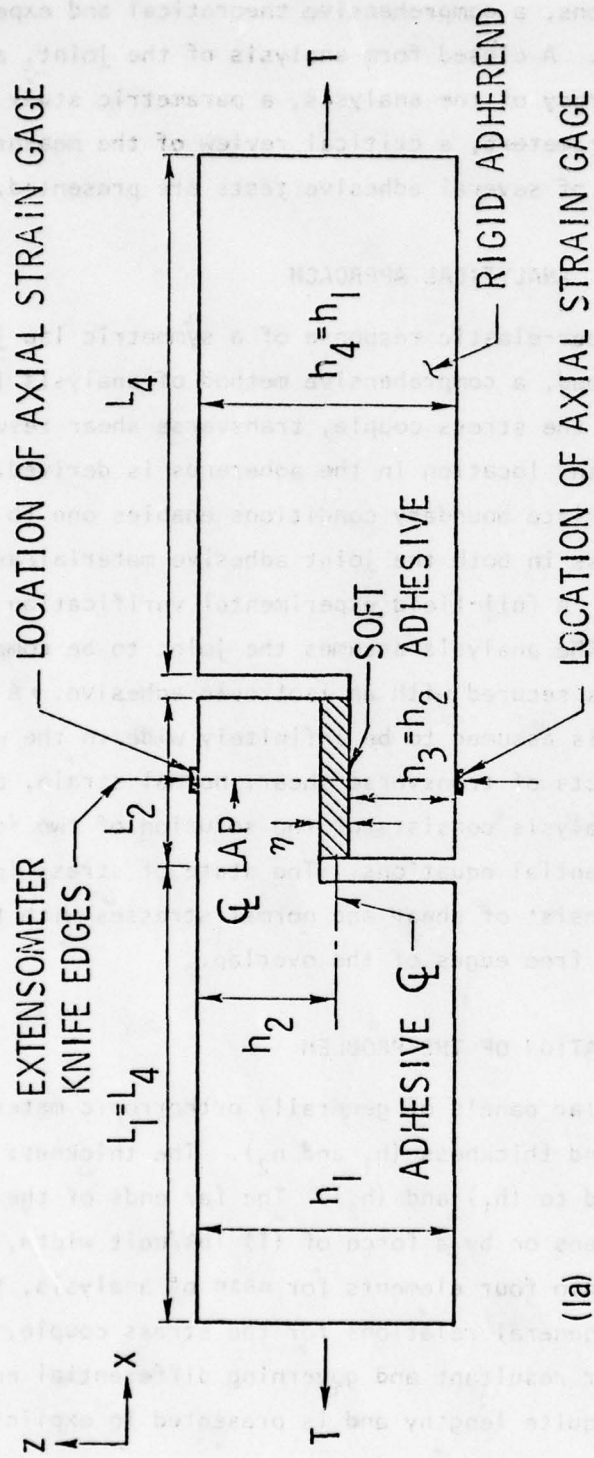

FIGURE A-1a. SYMMETRIC LAP TEST SPECIMEN

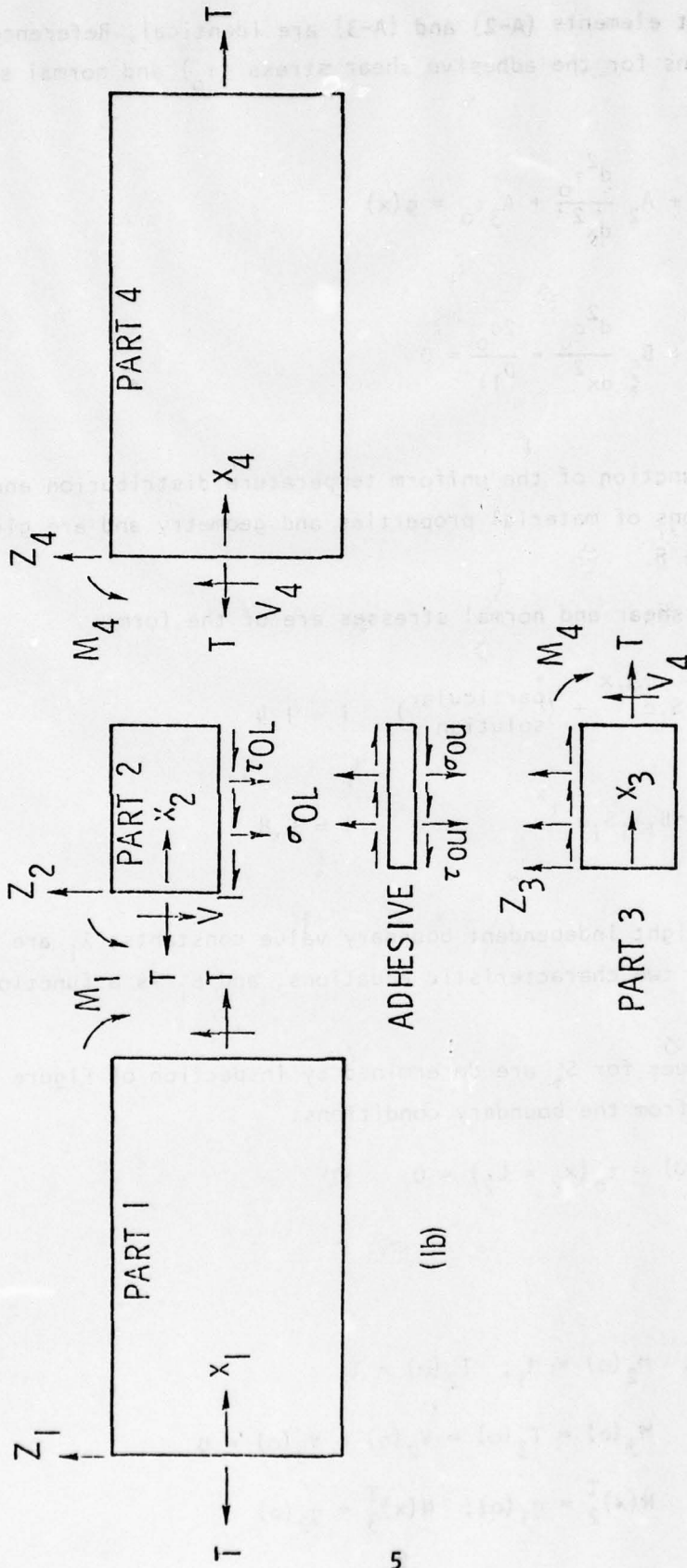

FIGURE A-1b. SYMMETRIC LAP TEST SPECIMEN

Assuming that elements (A-2) and (A-3) are identical, Reference 8 shows the governing equations for the adhesive shear stress (τ_o) and normal stress (σ_o) to be:

$$A_1 \frac{d^4 \tau_o}{dx^4} + A_2 \frac{d^2 \tau_o}{dx^2} + A_3 \tau_o = g(x) \quad A-1$$

$$B_4 \frac{d^4 \sigma_o}{dx^4} + B_5 \frac{d^2 \sigma_o}{dx^2} - \frac{2\sigma_o}{D_{11}} = 0 \quad A-2$$

where $g(x)$ is a function of the uniform temperature distribution and all constants are functions of material properties and geometry and are given explicitly in Reference 8.

The adhesive shear and normal stresses are of the form:

$$\tau_o(x) = S_i e^{\lambda_i x} + \text{(particular solution)} \quad i = 1, 4 \quad A-3$$

$$\sigma_o(x) = -\beta_i \lambda_i S_i e^{\lambda_i x} \quad i = 5, 8 \quad A-4$$

where S_i are the eight independent boundary value constants, λ_i are the eigenvalues of the two characteristic equations, and β_i is a function of $(A_1 - A_3)$ and λ_i .

Numerical values for S_i are determined by inspection of Figure A-1b. They are obtained from the boundary conditions:

$$\tau_o(x_2 = 0) = \tau_o(x_2 = L_2) = 0 \quad A-5$$

and

$$@ x_2 = 0; \quad M_2(o) = M_1; \quad T_2(o) = T$$

$$M_3(o) = T_3(o) = V_2(o) = V_3(o) = 0$$

$$N(x)_2^T = g_1(o); \quad N(x)_3^T = g_2(o) \quad A-6$$

$$\text{@ } x_2 = L_2; \quad M_3(L_2) = M_4; \quad T_3(L_2) = T$$

$$V_3(L_2) = V_2(L_2) = T_2(L_2) = M_2(L_2) = 0$$

$$N(x)_2^T = g_1(L_2); \quad N(x)_3^T = g_2(L_2)$$

A-7

Reference 8 shows that $M_1 = -M_4 = -\left(\frac{h_1}{2} - \frac{h_2}{2}\right)T$ and that $V_1 = V_4 = 0$. $N(x)_1^T$ is the axial load induced by thermal effects.

Figure A-2 displays the adhesive stress distribution in the symmetric lap joint. The dashed lines refer to a typical stress distribution one may anticipate if the specimen is improperly designed. This is primarily due to the effect on the specimen of geometric and material property mismatch. The result is the formation of significant stress concentrations at the ends of the overlap and an accompanying non-uniform shear stress state along the overlap length. A properly designed specimen's adhesive stress distribution is given by the solid lines in Figure A-2.

EXPERIMENTAL CONFIRMATION

To facilitate confidence in the analytical model and in turn its capacity for designing an optimum shear modulus specimen, both full-field photoelastic and strain gage tests were performed. PSM-1 photoelastic material with a fringe value of 40 psi/fr/in (6.9×10^3 N/fr/M), a Young's modulus of 340,000 psi (2344.8 MPa) and a Poisson's ratio of .38 was used to model the joint. A typical photoelastic model and its dimensions are shown in Figure A-3. Sheet thickness was .25 inches (6.35 mm). To facilitate a comparison between the experimental and analytical approaches, the photoelastic specimen's pertinent dimensions and material properties were input into the analytical routine. Results are reduced to field plots of the isochromatics shown in Figure A-4. Excellent correlation is seen to exist between the two models. The exceptions occurred when the gap to h_2 ratio was appreciably less than one. This is directly the result of the Saint Venant effect coming to the fore, whereby the load is physically introduced into the overlap area in a significantly different manner than that prescribed by the analytical model. This effect should be considered in the design of an optimum test specimen.

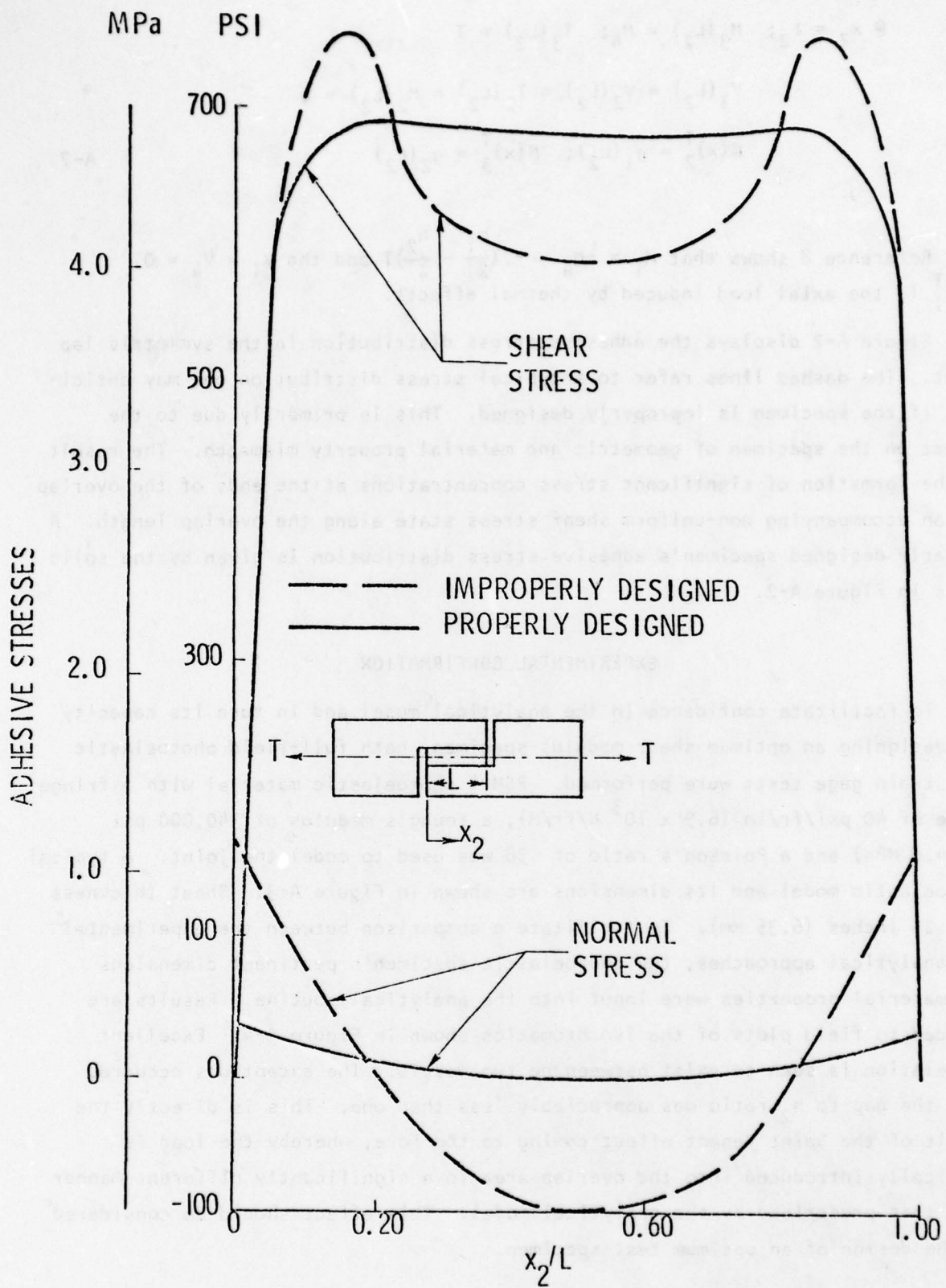

FIGURE A-2. TYPICAL ADHESIVE STRESS DISTRIBUTIONS

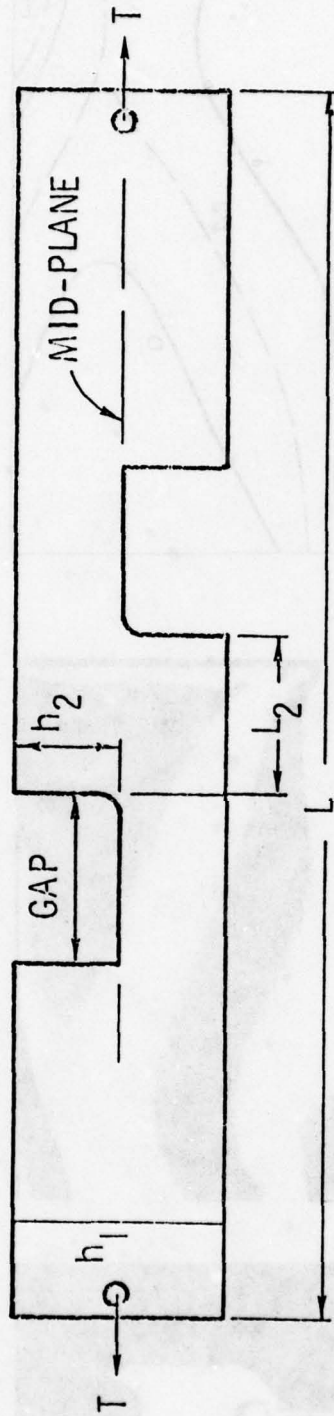
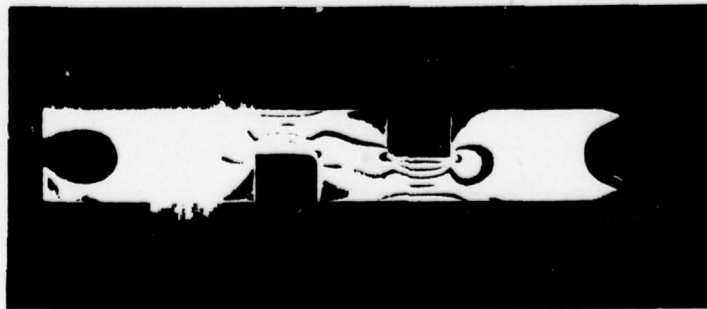

TABLE OF DIMENSIONS

	in	mm
h_1	1.500	38.10
h_2	.740	18.80
L	10.000	254.00
L_2	1.10	27.90

FIGURE A-3. PHOTOELASTIC MODEL



FULL-FIELD VIEW OF SPECIMEN ISOCHROMATIC PATTERN

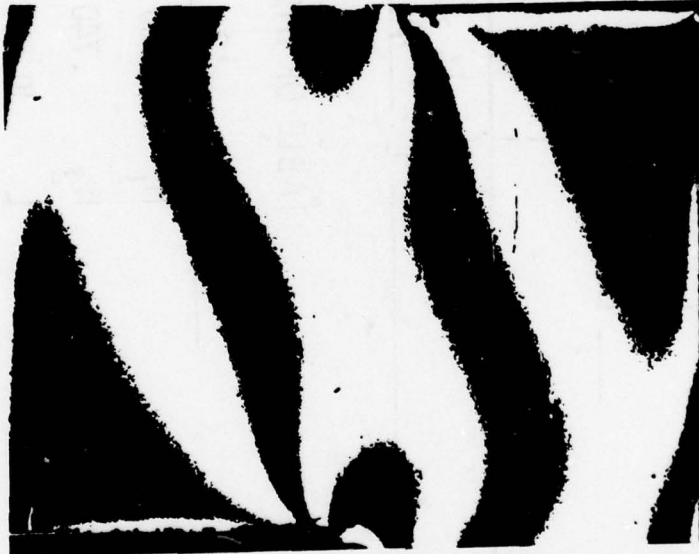

EXPERIMENTAL ISOCHROMATIC PATTERN IN OVERLAP AREA

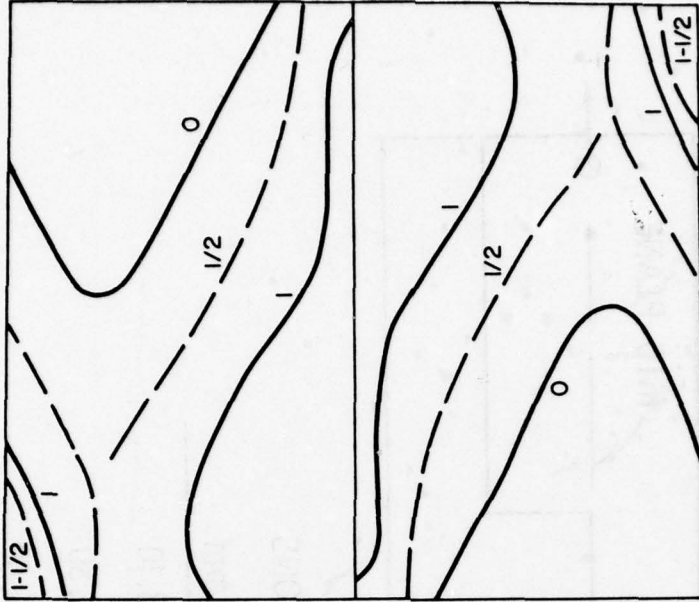

ANALYTICAL ISOCHROMATIC PATTERN (MIRROR IMAGE)

FIGURE A-4. PHOTOELASTIC VERIFICATION OF ANALYTICAL MODEL

An additional verification of the analytical model was made by mounting .032 inch gage length axial strain gages on the outer adherend surfaces of three 7075-T6 aluminum and four 1002-S fiberglass specimens, (Figure A-1). The adhesive was EA951. The strain gage readings reflected the strain due to the axial load and compressive moment. The tests were conducted at ambient temperature, 20-30 percent humidity and at a crosshead rate of .02 in/min (.508 mm/min) in an Instron tensile tester.

A summary of the test results and the accompanying theoretical predictions are given in Table A-1. The strain readings represent an average value of strain over the gage length. For purposes of comparison, the theoretical strain values are taken at the location of the centerline of the actual gages.

Judging the adequacy of the analytical model by use of strain gages in this instance is somewhat sensitive as one is trying to compare very small strain readings. Generally, minor errors like gage transverse sensitivity, variation in material properties, and sensitivity of the measurement circuitry can be significant in this region of strain measurement. Discrepancies of 10-20 micro-inches are reasonable. Therefore, after consideration of these effects and the reproducibility of the test data as seen from inspection of Table A-1, the authenticity of the analytical model would seem to be justified again.

OPTIMUM SPECIMEN DESIGN

Having ascertained the validity of the analytical model, it becomes desirable to determine the optimum geometry for test specimens composed of various adherend-adhesive material combinations. In conjunction with this, it is also desirable to define the constraints, if any, for the accurate implementation of such a test.

Such a study was undertaken. The pertinent parameters were adhesive effective shear modulus, lap length, adherend thickness, and primary modulus (Q_{11}). As many adhesives are isotropic and possess a Poisson's ratio close to 1/2, the effective tensile modulus was assumed to be three times the effective shear modulus. In this way the adverse effect of the normal stress in the model analysis is magnified.

TABLE A-1 SUMMARY OF SYMMETRIC LAP STRAIN GAGE DATA

Spec. Mat'l and No.	T = 220 lb.				T = 110 lb.							
	L [*]		h ^{**}		Test		Theory		Test		Theory	
	in	mm	in	mm	Gage Reading μ in/in	Strain at center- line of gage loca- tion (μ in/in)	Gage(1)	Gage(2)	Gage Reading μ in/in	Strain at center- line of gage loca- tion (μ in/in)	Gage(1)	Gage(2)
					Gage(1)	Gage(2)			Gage(1)	Gage(2)		
7075-T6-1	.265	6.73	.510	12.95	-71	-38	-88	-44	-18	-25	-22	-45
	.281	7.14	.509	12.93	-73	-67	-80	-70	-35	-35	-33	-33
	.453	11.50	.897	22.79	-23	-33	-42	-45	-27	-52	-30	-45
1002-S Glass-1	.275	6.98	.534	13.56	-70	-77	-64	-64	-37	-24	-30	-30
	.265	6.73	.534	13.56	-64	-42	-62	-50	-31	-19	-31	-20
	.703	17.85	.516	13.10	-50	-49	-65	-69	-28	-27	-34	-32
-6	.687	17.45	.516	13.10	-51	-51	-65	-58	-24	-24	-30	-30

* See Figure (1)

** h₂ ≈ .50 h₁

L₁ ≈ 114.3 mm

Width of specimens ≈ 25.4 mm

For this study, the constraints governing the selection of the optimum specimen geometry were:

1. The variation in shear stress (deformation) in the adhesive over $3/4$ of the overlap should be uniform within 10% (.07 Mpa).
2. The normal stresses in the adhesive should be minimized
3. If measurement of the adhesive shear modulus and proportional limit are to be made using a device attached to the adherends outer surface, (point A in Figure A-5), it should be placed at the joint centerline thereby minimizing the bending error introduced along the overlap.

Evaluation of the parametric results dictates that one understand the kinematics of the surface measurement system presently in use to measure specimen deformation during load application. Only then can one understand the errors inherent in using such a test specimen to obtain the adhesive effective shear modulus and the proportional limit shear stress.

Figure A-5 defines the kinematic relations that exist during a test. While the adhesive may deform uniformly (A'A'), the inability to have perfectly rigid adherends introduces an error attributable to moment relief (A'A''). Therefore, the surface measurement system may record a significant bending deformation error unless the moment effects in each adherend (A A'') offset each other. This is only the case at the center of the overlap region of the joint. Therefore, the location of the measurement system is important. Moreover, it emphasizes the desirability of developing a measurement system which can be attached at the adhesive-adherend interface.

Another possible source of error is the discrepancy between the normal shear stress thought to exist in the central portion of the joint and the actual value the adhesive does experience. This discrepancy is the result of the stress concentration associated with the free boundaries at the ends of the overlap. Finally, the sensitivity associated with a particular deformation measurement system is all important, especially for relatively rigid adhesive systems for which one wishes to measure small deformation values.

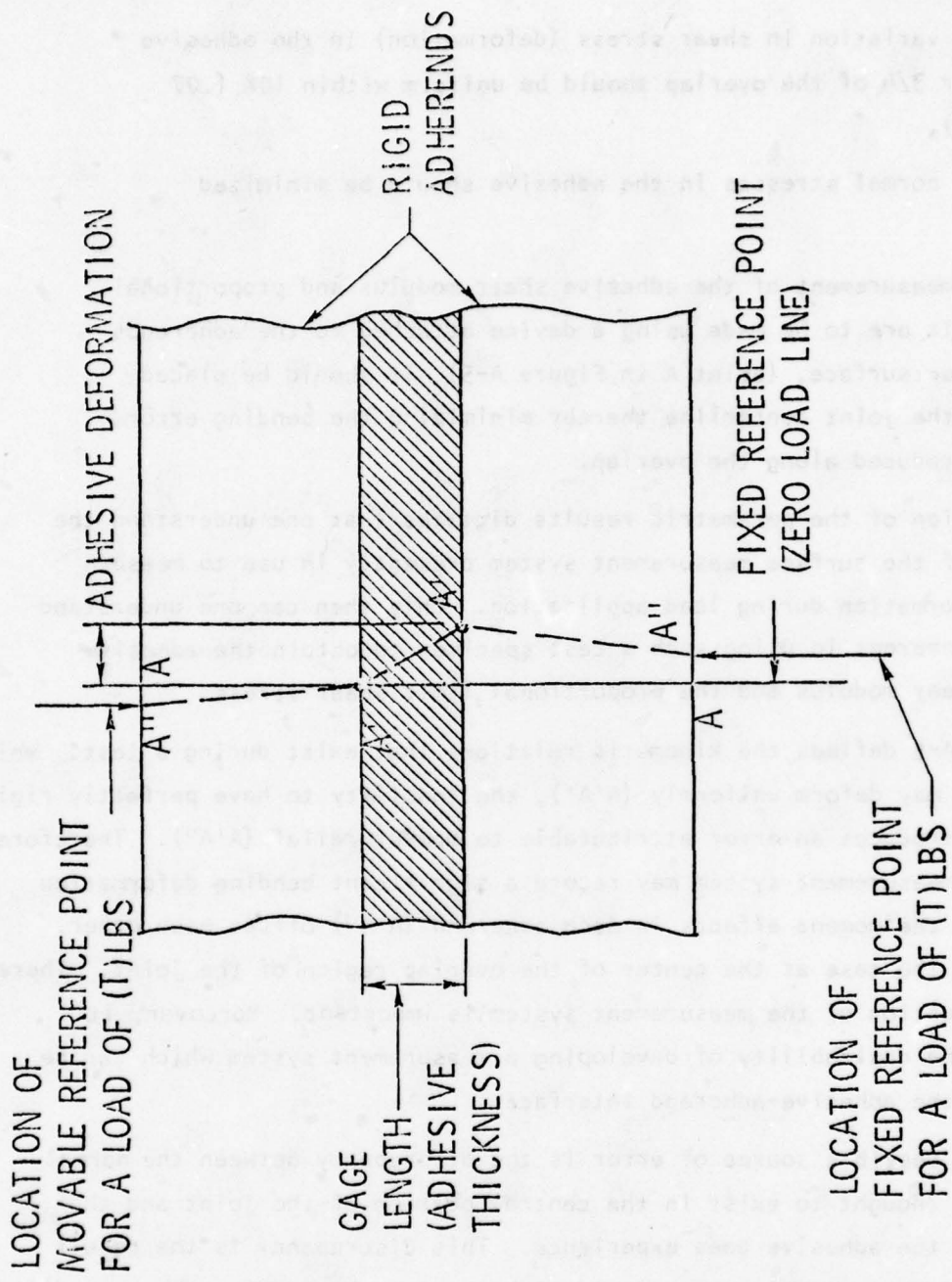

FIGURE A-5. SCHEMATIC REPRESENTATION OF THE KINEMATICS OF ADHESIVE DISPLACEMENT MEASUREMENT AT ADHEREND SURFACES

For this study the ratio of the primary elastic modulus (E) of the adherends (identical adherends only were considered) to the shear modulus of the adhesive (G) varied from 38 to 36,250. Specific optimum specimens are presented in Table A-2. The results are presented in two parts. Section (A) results are without restriction and presupposes that measurement of adhesive strain is possible at the adhesive-adherend interface. Section (B) results are valid when an adherend surface measurement system is employed subject to the restrictions specified in column (4).

Figure A-6 shows the percent error in measurement of the true adhesive deformation vs. placement of a measuring device along the adhesive-adherend interface. Within the inner 75 percent of the overlap length the error is a maximum of three percent only when the ratio of E/G is small. For a system that measures the adhesive strain at the adherend surface as in Figure A-5. Uniformity of adhesive deformation is similar to that presented in Figure A-6. However, results presented in Figure A-7 indicate that the upper limit of the capability of this measurement system is for an (E/G) value of approximately 2000. While uniformity of adhesive deformation is necessary, it is only useful if it can be measured accurately. Figure A-7 presents the percent error a surface measurement device would introduce in measuring the true adhesive deformation if it were positioned at other than the centerline of the overlap. This error is due to the anti-symmetry of the moments in each adherend. They are only of equal magnitude and opposite sense at the centerline of the overlap. Lastly, while it is feasible to thicken the adherends (h_1) beyond the values listed in Table A-2, it was observed that no appreciable improvement in the specimen's desired properties were obtained. In some instances a deterioration was noted.

The limitations of the surface measurement system, namely, the material waste associated with the larger specimens and its limited capability to obtain accurate adhesive deformation data, make it desirable that a better adhesive measurement system be developed. Such a system is presently in final checkout. A schematic of the system is shown in Figure A-8. Fundamentally, it uses a three point pick-up on each side of the specimen. It is attached at the adhesive-adherend interface. The net effect is to cancel out adherend deformation effects while giving an average adhesive deformation reading. Further details of the system can be obtained from Mr. Ray Kreiger of the American Cyanamid Company of Havre de Grace, Maryland.

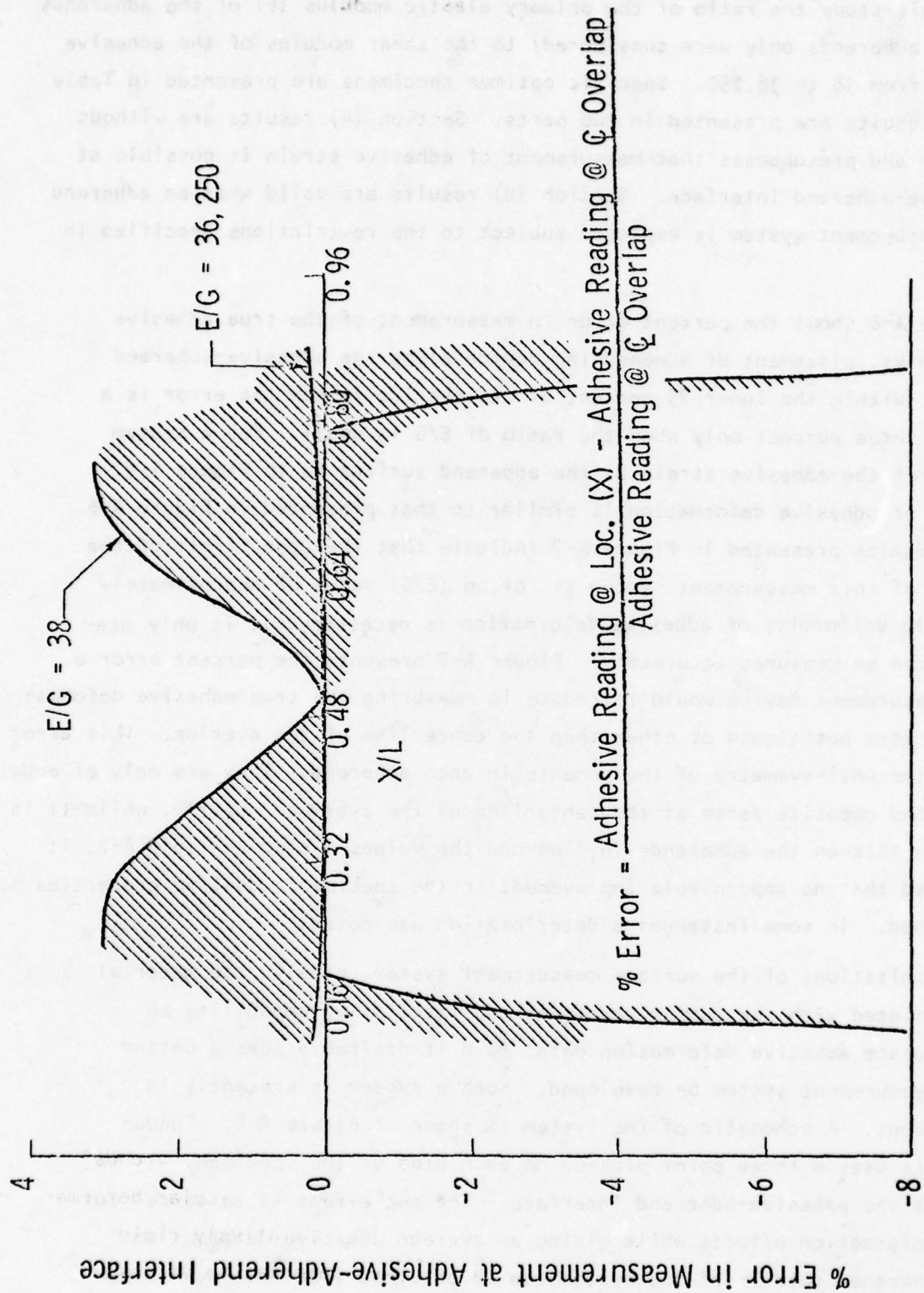

FIGURE A-6. PERCENT ERROR IN MEASUREMENT OF THE TRUE ADHESIVE DEFORMATION vs. LOCATION OF MEASUREMENT DEVICE

TABLE A-2 - SUMMARY - OPTIMUM SHEAR SPECIMENS

(A) ADHESIVE MEASUREMENT SPECIMENS

Primary Elastic Modulus		h_1^*		L_2^*		*** Range of Usage In Terms of Adhesive Modulus Factor (C_s) 10^6 lb/in^3 (Kg/M^3)
MSI	MPa	in	mm	in	mm	
6.8	4.7	.75	19.05	.50	12.7	Full Range
10.3	7.1	.75	19.05	.36	9.14	Full Range
16.0	11.0	.75	19.05	.36	9.14	Full Range
29.0	20.0	.75	19.05	.36	9.14	Full Range

(B) ADHEREND SURFACE MEASUREMENT SPECIMENS

Primary Elastic Modulus		h_1^*		L_2^*		*** Range of Usage In Terms of Adhesive Modulus Factor (C_s) 10^6 lb/in^3 (10^9 Kg/M^3)
MSI	MPa	in	mm	in	mm	
6.8	4.7	.75	19.05	.40	10.16	.20→6.0 (5.54→166.39)
6.8	4.7	1.50	38.10	.88	22.35	** 6.0→25.0 (166.39→693.30)
10.3	7.1	.90	22.86	.40	10.16	.20→6.0 (5.54→166.39)
10.3	7.1	2.50	63.50	1.30	33.02	6.0→25.0 (166.39→693.30)
16.0	11.0	.90	22.86	.40	10.16	.20→6.0 (5.54→166.39)
16.0	11.0	2.50	63.50	1.30	33.02	6.0→25.0 (166.39→693.30)
29.0	20.0	.90	22.86	.40	10.16	.20→6.0 (5.54→166.39)
29.0	20.0	2.50	63.50	1.30	33.02	6.0→25.0 (166.39→693.30)

* Refers to dimension shown in Figure (1)

** No optimum found

*** $C_s = \frac{\text{Shear Modulus}}{\text{Adhesive Thickness}}$

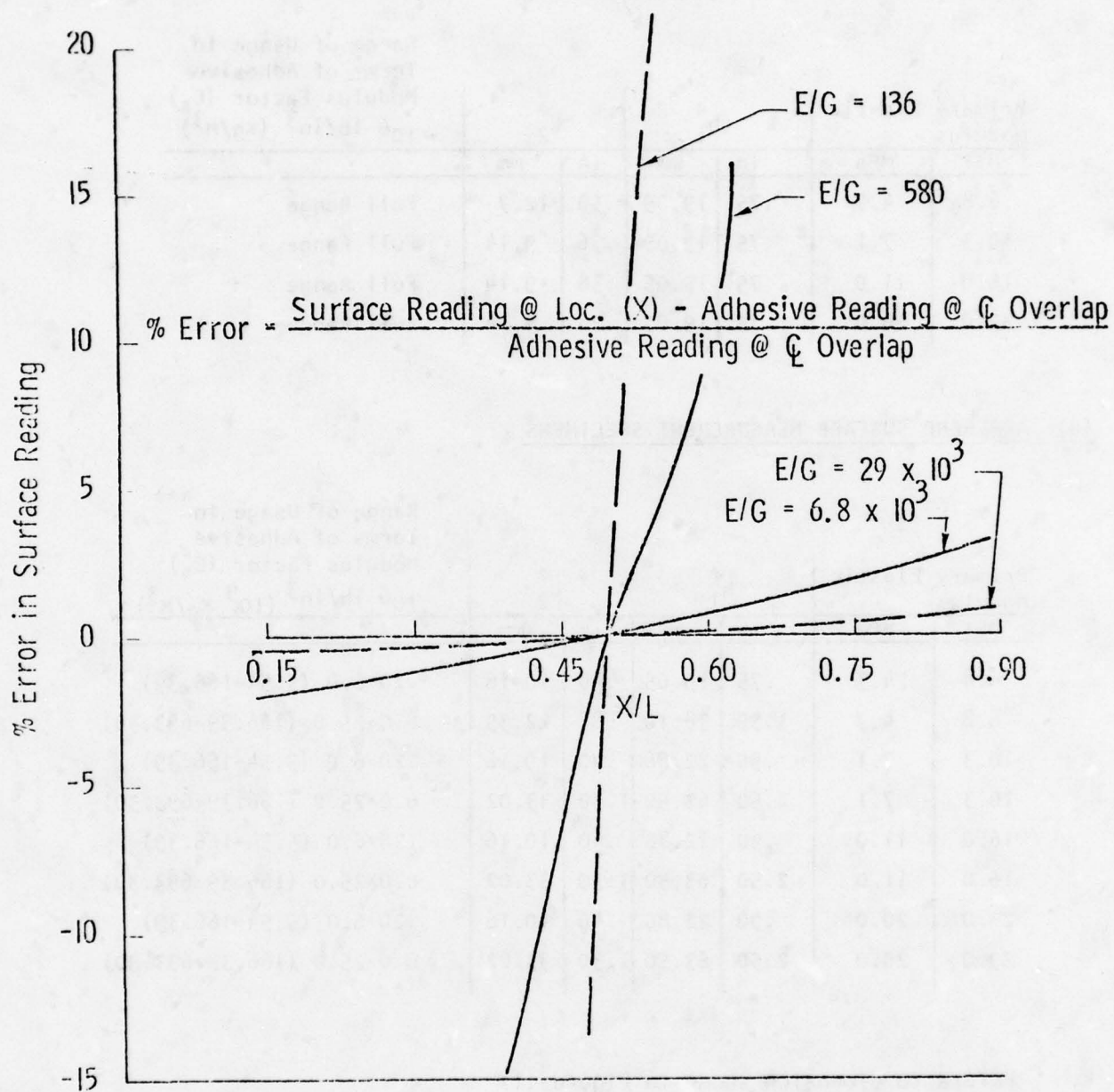

FIGURE A-7. PERCENT ERROR IN MEASUREMENT OF TRUE ADHESIVE DEFORMATION vs. LOCATION OF KNIFE EDGES ALONG ADHEREND SURFACE

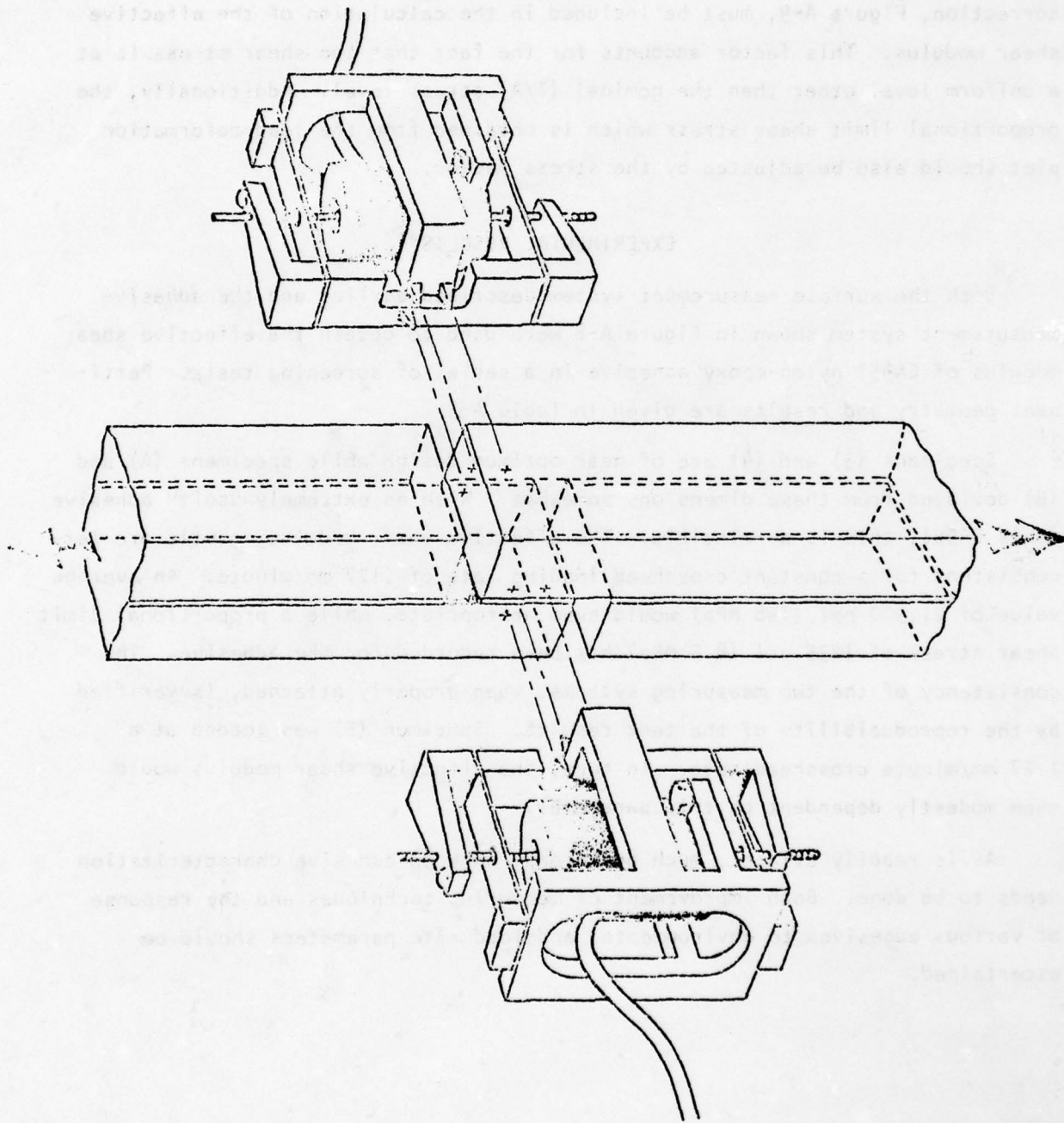

FIGURE A-8. NEW ADHESIVE DEFORMATION MEASUREMENT DEVICE

The effective thin film shear modulus (G_{eff}) of the adhesive can be calculated per Equation (A-8).

$$G_{eff} = \frac{(\text{Load})(\text{Adhesive thickness})(\text{Stress Factor})}{(\text{Surface Area})(\text{Adhesive Deformation})} \quad \text{A-8}$$

Again, results of the parametric study indicate that a stress factor correction, Figure A-9, must be included in the calculation of the effective shear modulus. This factor accounts for the fact that the shear stress is at a uniform level other than the nominal (T/A) stress level. Additionally, the proportional limit shear stress which is obtained from the load-deformation plot should also be adjusted by the stress factor.

EXPERIMENTAL RESULTS

Both the surface measurement system described earlier and the adhesive measurement system shown in Figure A-8 were used to obtain the effective shear modulus of EA951 nylon-epoxy adhesive in a series of screening tests. Pertinent geometry and results are given in Table A-3.

Specimens (3) and (4) are of near optimum design while specimens (A) and (B) deviated from these dimensions somewhat. With an extremely "soft" adhesive as is EA951, this is permissible. The effective shear modulus results are very consistent for a constant crosshead loading rate of .127 mm/minute. An average value of 21,500 psi (148 MPa) would seem appropriate, while a proportional limit shear stress of 1235 psi (8.5 MPa) has been recorded for the adhesive. The consistency of the two measuring systems, when properly attached, is verified by the reproducibility of the test results. Specimen (B) was loaded at a 1.27 mm/minute crosshead rate. In turn, the effective shear modulus would seem modestly dependent on this parameter.

As is readily evident, much additional work on adhesive characterization needs to be done. Both improvement of measuring techniques and the response of various adhesives to environmental and load rate parameters should be ascertained.

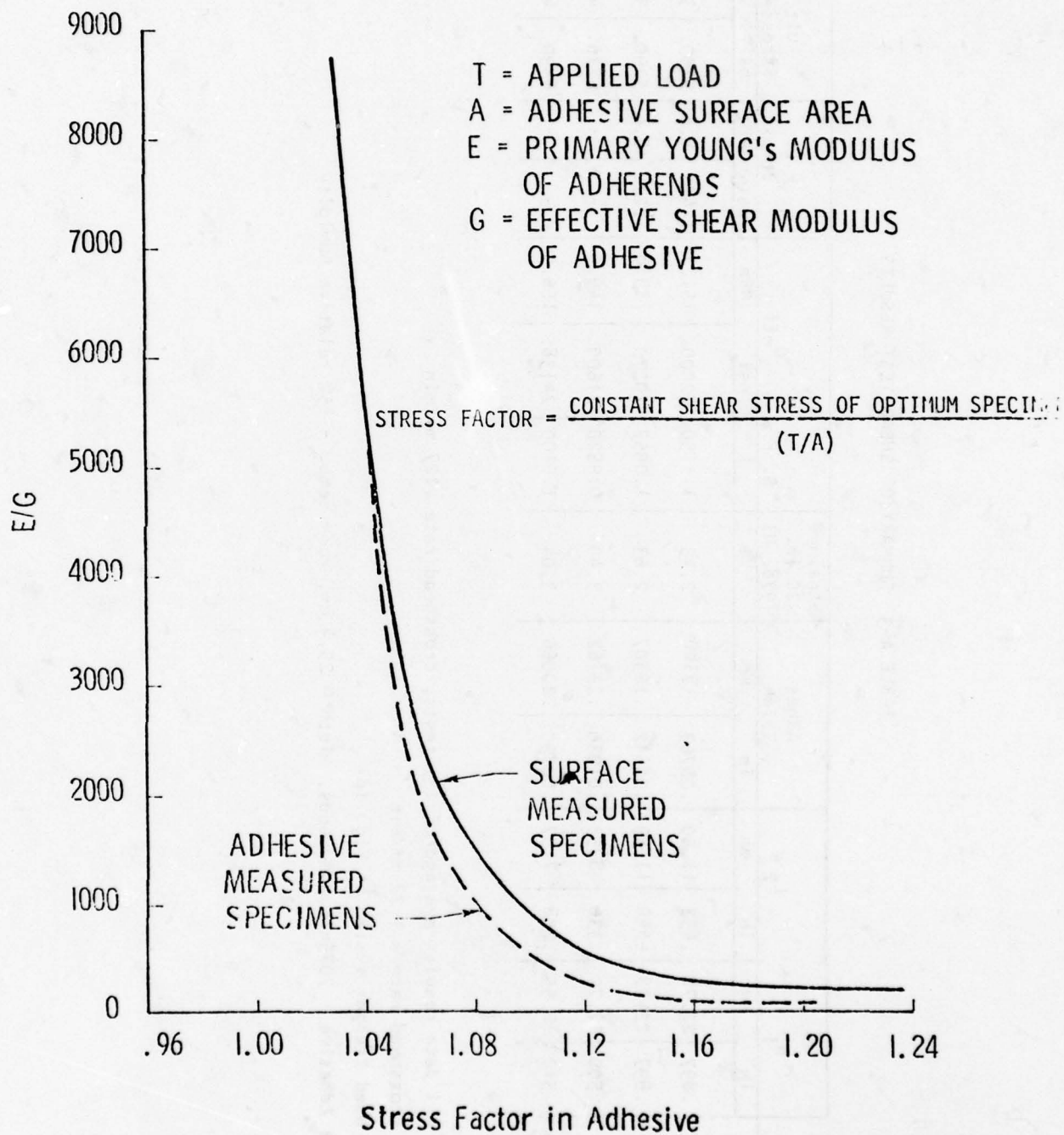

FIGURE A-9. E/G VERSUS STRESS FACTOR

TABLE A-3 SUMMARY OF SHEAR TEST RESULTS

Spec.	h ₁		L ₂		Adhes. Thick		Strain @ 220 lb. (978. N) %	S. F.	G _{eff}		P.L. Stress		Ult. Stress=T/A		Type Failure
	in	mm	in	mm	in	mm			psi	MPa	psi	MPa	psi	MPa	
3	.897	22.78	.453	11.50	.00763	.19380	2.13	1.1150	22000.	151.7	1242.	8.6	5209.	35.9	adhes-cohes
4**	.897	22.78	.446	11.33	.00642	.16307	2.63	1.0957	20270.	139.8	1227.	8.5	5290.	36.5	adhes-cohes
A	.500	12.70	.336	8.53	.01030	.26162	3.40	0.9520	21600.	149.0	-	-	6776.	46.7	adhes-cohes
B*	.510	12.95	.298	7.57	.00790	.20066	3.04	1.0100	24138.	166.5	-	-	6890.	47.5	adhes-cohes

All data results average of (3) tests, crosshead rate .127 mm/min

* Crosshead rate = 1.27 mm/min

** Used Kreiger system of Fig. (8)

EA951 Adhesive - 7075-T6 adherends, width ≈ 25.4 mm, room temp. - 15% relative humidity

REFERENCES

- [1] Zabora, R. F., "Adhesive Property Phenomena and Test Techniques", AD729873, July, 1971.
- [2] Hughes, Edward J. and Rutherford, John L., "Study of Micromechanical Properties of Adhesive Bonded Joints", Technical Report 3744, Aerospace Research Center, General Precision Systems, Inc., Little Falls, New Jersey, August, 1968.
- [3] McCarvill, W. T. and Bell, J. P., "Torsional Test Method for Adhesive Joints", Journal of Adhesion, Vol. 6, pp. 185-193, 1974.
- [4] Corvelli, N. and Saleme, E., "Analysis of Bonded Joints", Grumman Aerospace Corporation, Advanced Development Report No. ADR-02-01-70, July, 1970.
- [5] Kuenzi, E. W. and Stevens, G. H., "Determination of Mechanical Properties of Adhesives for Use in the Design of Bonded Joints", FPL Report No. 011, September, 1963.
- [6] Lin, C. J. and Bell, J. P., "Effect of Polymer Network Structure upon the Bond Strength of Epoxy-Aluminum Joints", Journal of Applied Polymer Science, Vol. 16, pp. 1721-1733, 1972.
- [7] Renton, W. J. and Vinson, J. R., "The Analysis and Design of Composite Material Bonded Joints Under Static and Fatigue Loadings", Air Force Office of Scientific Research TR No. 73-0494, August, 1973.
- [8] Renton, W. J. and Vinson, J. R., "The Analysis and Design of Anisotropic Bonded Joints", Air Force Office of Scientific Research TR No. 75-0125, August, 1974.
- [9] Renton, W. J. and Vinson, J. R., "Shear Property Measurements of Adhesives in Composite Material Bonded Joints", A.S.T.M. Composites Reliability Conference, April, 1974, STP-580.
- [10] Kreiger, Raymond B., Jr., "Evaluating Structural Adhesives under Sustained Load in Hostile Environment", presented at the 5th National SAMPE Technical Conference, October, 1973.

REFERENCES

[1] Sabors, A. F., "Adhesive Property Phenomena and Test Techniques", *Adhesive Journal*, 1971.

[2] Higgins, Edward J. and Kauterford, John L., "Study of Microstructural Properties of Adhesive Bonded Joints", Technical Report 1994, Aerospace Research Center, General Precision Systems, Inc., Little Falls, New Jersey, August, 1969.

[3] McCarroll, W. T. and Bell, J. R., "Tensile Test Method for Adhesive Joints", *Journal of Adhesion*, Vol. 4, pp. 185-197, 1974.

[4] Goulet, R. and Salovey, E., "Analysis of Bonded Joints", *Aviation Space Corporation, Advanced Development Report No. ADA-01-0170*, July, 1970.

[5] Kauterford, E. W. and Stevens, G. H., "Determination of Mechanical Properties of Adhesives for Use in the Design of Bonded Joints", *TR Report No. 011*, September, 1963.

[6] Lin, C. J. and Bell, J. R., "Effect of Polymer Network Structure upon the Bond Strength of Epoxy-Amine Joints", *Journal of Applied Polymer Science*, Vol. 16, pp. 1151-1177, 1972.

[7] Patton, W. J. and Vinson, J. A., "The Analysis and Design of Composite Laminated Bonded Joints", *TR Report No. 011*, August, 1974.

[8] Patton, W. J. and Vinson, J. A., "The Analysis and Design of Adhesive Bonded Joints", *TR Report No. 011*, August, 1974.

[9] Patton, W. J. and Vinson, J. A., "Stress Property Relationships of Adhesives in Composite Material Bonded Joints", *TR Report No. 011*, August, 1974.

[10] Brainerd, Raymond B., "Predicting the Mechanical Properties of Adhesive Bonded Joints in Hostile Environments", presented at the 5th National Technical Conference, October, 1973.

APPENDIX B

ADHESIVE SPECIFICATIONS

APPENDIX B

ADHESIVE JOINT FABRICATION AND TEST SPECIFICATIONS

Based on review of the adhesive test specimen and methodology literature per the evaluation criteria defined in Section III and the results of studies in regards to adhesive deformation measurement, specimen analysis, detection of defects in adhesive bondlines, surface roughness, and specimen alignment, the following adhesive fabrication and test specifications were formulated. Moreover, after their use throughout the performance of this program, selected revisions have been made so that the final format of the specifications presented within this report reflects the practicability of "hands on" usage.

The format used is that followed in ASTM Test Specifications as these specifications will be introduced to the appropriate ASTM Review Committee for possible adoption.

ATTACHMENT I - Fabrication Specification for Thick Adherend, Butt and Scarf Joints

ATTACHMENT II - Preliminary Test Specification for Characterizing the Static Shear (Tension) Stress Strain Response of Structural Adhesives

ATTACHMENT III - Preliminary Test Specification For Characterizing the Shear (Tension) Creep-Recovery Response of Structural Adhesives

ATTACHMENT IV - Preliminary Test Specification for Characterizing the Shear (Tension) Fatigue Stress-Strain Response of Structural Adhesives

ATTACHMENT I

1. FABRICATION SPECIFICATION FOR THICK ADHEREND, BUTT AND SCARF JOINTS

1. SCOPE

1.1 This specification provides information necessary to fabricate thick adherend lap-shear, butt and scarf adhesive bonded joints that are useful for the mechanical characterization of adhesive systems.

1.2 Introduction

1.2.1 Fabrication of bonded joints may be described in three sequential steps. These are machining of adherend specimens, preparation of the adherend surfaces to be bonded and/or primed and the bonding of the adherends.

1.3 Machining of Adherends

1.3.1 General

1.3.1.1 Adherends should be machined from plate stock. Machine the features of the joint into two pieces of material so that they make a specimen gang 7.5 inches wide by 9.75 inches long, with the joint located 4.5 inches from one end (Figure 1a). Care must be taken at this time that the ends are parallel to the center of the joint. The grain direction of the plate should be in the 9.75 inch direction. Standard metal machining procedures for a particular metal are recommended. Machining methods which may lead to introduction of high residual stress and/or cold-worked layers on the surface to be bonded should be avoided. The surfaces to be bonded should be free of burrs. Test specimens should conform to the geometrical dimensions given in the test specifications for characterizing the static, fatigue and creep response of structural adhesives. The prepared adherend specimens prior to surface preparation should have:

- o The adhesive face flat to within .000125 inch/inch of width unless it is desired to study surface roughness effects.
- o The adhesive face surface is to have a roughness \approx 32 microinches with the stylus traverse made in several directions.

1.3.2 Use of Drill Jig

1.3.2.1 To insure specimen alignment, adhesive thickness control and that the load is applied in a truly axial manner once the test specimens are ready to be tested, the drill jig shown in Figure 1b is recommended. Its use prior to adherend chemical surface preparation procedures is as follows:

- o Place both halves of the specimen gang on the drill jig base plate (A) as shown, and shim the joint to the proper clearance (i.e. adhesive thickness) as in Figure 1a. Slip the upper half of the drill jig (B) over the studs. Be sure the specimen gang is seated against the alignment dowels and tighten the fixture lock nuts, firmly fixing the halves of the specimen gang with the joint held at its proper clearance.
- o Drill and ream all of the holes marked (1). (Six .500 inch diameter and two .375 inch diameter).

1.4 Surface Preparation of Adherends

1.4.1 Scope

1.4.1.1 Surface preparation of aluminum surfaces to be bonded should comply with the phosphoric acid anodization procedure which follows. For other adherend materials, the surface preparation procedure shall be in accordance with the recommendations of the adhesive manufacturer, unless it is desired to evaluate specific methods of surface preparation. All surfaces to be bonded shall be free from visible flaws, scratches or imperfections.

1.4.2 Introduction

1.4.2.1 This process covers the procedures used in preparing aluminum panels for structural adhesive bonding with a phosphoric acid anodized surface using 7075-T6 or 2024-T3 aluminum alloys.

1.4.3 References

<u>Reference</u>	<u>Sources</u>	<u>Title</u>
(a) BAC 5555	Boeing Process Spec.	Phosphoric Acid Anodizing of Aluminum for Structural Bonding
(b) BAC 5408	Boeing Process Spec.	Vapor Degreasing

(c)	BAC 5514	Boeing Process Spec.	Common Bonding Requirements for Structural Adhesives
(d)	BAC 5713	Boeing Process Spec.	Application and Removal of Temporary Strippable Protective Coatings
(e)	BAC 5749	Boeing Process Spec.	Alkaline Cleaning
(f)	BAC 5750	Boeing Process Spec.	Solvent Cleaning
(g)	BAC 5763	Boeing Process Spec.	Emulsion Cleaning
(h)	DPS 11.08	McDonnell Douglas Spec.	Phosphoric Acid Anodizing of Aluminum

1.4.4 Materials and Equipment

- (a) Phosphoric Acid, 85% Technical Grade
- (b) Deionized Water
- (c) Vats
- (d) Trichlorethylene
- (e) Alkaline Cleaning Solutions: Turco 4215-S
- (f) Deoxidizing Solution: Sodium Dichromate (Technical grade)
Sulfuric Acid (Concentrated)
- (g) Cotton gloves
- (h) Aluminum wire holder
- (i) Aluminum wire hangers
- (j) Polarizing filter lens
- (k) DC power unit
- (l) Lead electrodes

1.4.5 Preparation of Solutions

- (a) Vought Bond Clean
- (1) Vapor Degrease - All parts are carried through a vapor degrease using trichloroethane prior to alkaline cleaning and after which parts are air dried.

(2) Alkaline Cleaning Solution

		<u>Use</u>
Turco 4215-S	7 oz./gal.	14 oz.
Deionized Water		2 gal.
Temperature Maintenance		155°F ± 10°F

(3) Deoxidizing Solution

Sodium Dichromate	Technical grade	1 part by weight
Sulfuric Acid (concentrated)	1.86 sp. gr.	10 parts by weight
Distilled Water		30 parts by weight
Operating Temperature		160°F

(b) Anodizing Bath

Phosphoric Acid (85% Technical Grade)	11-15 oz./gal.	13 oz.
Deionized Water		1 gal.
Operating Temperature - Room Temperature within		(-5°F + 20°F)

1.4.6 Operations Flow Chart

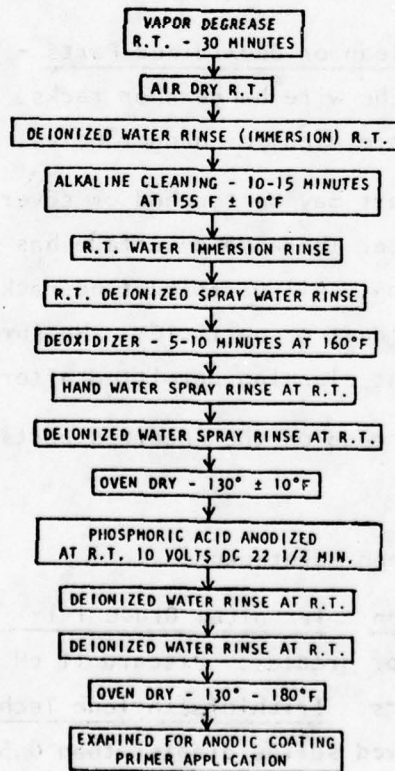

1.4.7 Requirements for Quality

1.4.7.1 Inspection of Parts - Minimum acceptability requirements preclude the use of scratched, or bent parts or otherwise marked which cannot be removed during the solvent cleaning operation. Parts having gummed labels remaining after chlorinated solvent cleaning will not pass acceptance requirements before the anodizing step.

1.4.7.2 Verification of Degreased Surfaces - Surfaces which have proper cleaning thru the degreasing operation will exhibit an absence of ink marks on labels. Water rinsed surfaces will have no water breaks in 2 minutes.

1.4.7.3 Reagent Acceptability - Cloudy or otherwise discolored solvent or rinse water is unacceptable. Solvents shall have no more than 0.5% total dissolved solids, determined according to ASTM D-1353. There should be no precipitate in either. Both the alkaline cleaning solution and the deoxidizer are cloudy and have a precipitate normally present. Total dissolved solids limit for the alkaline clean solution shall not exceed 750 ppm chemically determined.

1.4.7.4 Handling of Parts - Parts are handled either in a wire rack or with aluminum wire hangers.

- (a) Degreased, Alkaline Clean or Deoxidized Parts - White cotton gloves are used in touching the wire hangers or racks. Only corners of parts not used for bonding are used for hanger holes.
- (b) Anodized Parts - No part may be touched or covered with any material (even Kraft paper) after the anodic surface has been applied and before primer application. All parts must be racked or hung in areas free from circulating dust or particles. No surface wiping is acceptable nor is any solvent cleaning permitted after anodizing.
- (c) Primer application is made on the anodized parts within 8 hours after anodizing.

1.4.8 Operation of Baths and Maintenance

1.4.8.1 Degreasing Solution - Technical Grade 1-1-1 Trichloroethane (Methyl) Chloroform Mil-T-81533 pH 6.5 or greater. Discard if pH drops below 6.5 or if clearness or discoloration occurs. Trichloroethylene Technical Grade - Neither solvent shall have total dissolved solids greater than 0.5%. Use at room temperature.

1.4.8.2 Alkaline Cleaning Solution - Turco 4215-S - Maintain concentration between 37 and 43 pounds per 100 gallon. Operate at $155^{\circ} \pm 10^{\circ}\text{F}$.

1.4.8.3 Deoxidizing Solution - By weight use 1 part sodium dichromate, 10 parts sulfuric acid and 30 parts distilled water. Operate at 160°F .

1.4.8.4 Anodizing Bath - Technical grade phosphoric acid (H_3PO_4) use 11-16 oz/gal (deionized water). Total acidity is maintained at this level. Operating temperature is maintained at room temperature (or 5°F less and up to 20°F more), range being 65°F to 90°F . Current densities are 4-6 amps/ft² depending on part.

1.4.8.5 Rinse Solutions - Rinsing of all parts is by immersion only and a double rinse operation is carried out subsequent to the Alkaline cleaning operation. All rinse water is maintained at neutral pH and total dissolved solids will not exceed 1000 ppm. Final rinse operation where double rinses are used will not exceed 50 ppm dissolved solids. Particle count may be determined chemically or by Coulter Counter or equivalent measurement made by turbidity determination using a Klett photometer.

1.4.9 Part Acceptability After Anodization

1.4.9.1 Scratched or Damaged Parts - Some marked or shallow scratches may appear only after final drying and observation of the surfaces for these defects is carried out subsequent to anodizing and prior to primer application.

1.4.9.2 Water Marks and Streaking - A burnished character to the entire surface is the normal state with slight "graining" or linings (grey or silvery in color, no brown or black) in one direction. Obvious deep grooving or lining is unacceptable and would indicate unusual etching during the deoxidizing step.

1.4.9.3 Color - An obvious silvered hue to the entire surface is normal and the phosphoric anodic coat is not properly observable without the aid of a polarizing lens.

1.4.9.4 Anodic Surface Examination:

- (a) A white fluorescent lamp is used and projected onto the surface of the part to be examined so that the incident angle of this light from the lamp to the plane of the part surface is 5 degrees or less. (More than a 5° incident angle will not yield the color changes mentioned in subsection 4.9.3).

- (b) Place a polarizing filter lens between the part and the observer and rotate the lens through 180 degrees.
- (c) Observe the surface of the part for interference colors.
- (d) Anodic coating is confirmed by the appearance of yellow to deep green to purple colors.

1.4.9.5 Control Specimen - A control specimen of the parent material approximately 4 inches in length by one inch wide by .063 inches thick shall be included with each set of adherends to be phosphoric acid anodized. This specimen shall be used to verify the quality of the anodic surface coating if adhesive bond material characterization test results are deficient. The control specimen is to be bent upon removal from the anodization bath so as to fracture the anodized layer formed on the aluminum adherend surface. Inspection of the anodic layer characteristics can be conducted using SEM or other NDI inspection techniques on an as needed basis. The control specimen should be labeled in a manner consistent with that particular set of adherend specimens.

1.4.10 Priming of Surfaces to be Bonded

1.4.10.1 The priming of surfaces, once they have gone through appropriate surface preparation procedures, shall follow the recommended procedure of the manufacturer unless special procedures are being investigated. However, considering the tendency of most primers, especially BR-127, to settle on standing, careful control will be maintained on the percent solids of each individual aliquot of all primers. These will be determined gravimetrically. Overage primer should not be used. The chemical composition of the primer shall be verified by obtaining select analytical data on its chemical composition. This data should include: percent curing agent, Oxirane ratio, percent solids, percent inhibitor and percent pigment. A record of its environmental history prior to use shall also be maintained.

1.5 Bonding Procedure

1.5.1 General

1.5.1.1 The chemical composition of the adhesive shall be verified by obtaining select analytical data on its chemical makeup. This data should include:

percent curing agent, Oxirane ratio, percent water content (VPC) and Butadiene ratio when applicable. The environmental history of the adhesive prior to its use shall also be maintained. Definitive measures should be instituted to ensure that overage adhesives are not used.

1.5.1.2 The bonding fixture recommended is shown in Figure 1b. It is designed to ensure good alignment and uniform adhesive thickness control. The fixture is applicable for adhesives requiring ambient or high temperature cure cycles under pressure. Detailed use of the fixture to ensure axially of the specimen and superior bondline control is given below.

1.5.1.3 The accuracy of the mechanical characterization test data for adhesive bonds will depend on the conditions under which the bonding process is carried out. Unless otherwise agreed upon by the manufacturer and the purchaser, the bonding conditions shall be prescribed by the manufacturer of the adhesive. In order to ensure that complete information is available to the individual conducting the tests, the manufacturer of the adhesive shall furnish numerical values and other specific information for each of the following variables:

- o Complete mixing directions for the adhesive if applicable.
- o Conditions for application of the adhesive, including the rate of spread or thickness of film, number of coats to be applied, whether to be applied to one or both surfaces, and the conditions of drying where more than one coat is required.
- o Assembly conditions before initiation of the cure cycle including pressure, room temperature, relative humidity, length of time, and whether open or closed assembly is to be used.
- o *Curing conditions, including the amount of pressure (pressure bag, press platens, etc.), heat-up rate, cool down rate, and the temperature of the assembly when under pressure. It should be stated whether this temperature is that of the bondline or of the atmosphere at which the assembly is to be maintained.*

1.5.1.4 A range may be prescribed for any variable by the manufacturer of the adhesive if it can be assumed by the test operator that any arbitrarily chosen value within such a range, or any combination of such values for several variables will provide acceptable results.

1.5.2 Use of Bonding Jig

1.5.2.1 The bonding jig should be used in order to ensure accurate adhesive thickness control and specimen alignment.

1.5.2.2 The procedure to follow is:

- o Apply a mold release agent to the bonding jig surfaces which are to be in contact with the adherend surfaces. Place the specimen gang in the bonding alignment fixture (C) (See Figure 1b), with a strip of adhesive at room temperature and of sufficient length and width, in the joint. The bonding alignment fixture is carefully made so that it maintains exactly the same hole spacing in the specimen gang that the drill jig established. The joint will be held, therefore, in the same relationship to which it was shimmed in Section 1.3.2.1. Shim stock of the desired thickness is inserted at each end of the bondline (for butt and scarf joints only) with adequate pressure applied by the tapered end pins (D in Figure 1b), being inserted to hold the shim stock in place. For all joints after upheat to the cure temperature is reached, the tapered end pins are turned in for application of full pressure. Prior to heating, apply sealing tape at the ends of the bondline openings to prevent adhesive runout at locations (G).

- o Install the bonding plate (F) and place the entire assembly in the bonding press.

- o Close the platens to apply light pressure on the bonding assembly and begin to apply heat. As the adhesive reaches cure temperature it will soften and permit the joint to be properly aligned by means of the tapered end pins (D), with release of platen pressure. Since the bonding jig is made of the same material as the specimen gang, there will be very little effect on the bond thickness due to thermal expansion effects.

- o Apply the proper platen pressure and allow the adhesive to cure for the prescribed amount of time at the proper temperature. After the adhesive has cured, remove the pins at (D) and relieve the platen pressure. Maintain the platens in contact with the jig to insure uniform cooling, assuming water cooled platens are to be used. In this configuration, cooling may begin without fear of straining the bonded joint through thermal effects due to uneven cooling of the jig and bonded joint.

1.5.3 Final Specimen Preparation

1.5.3.1 After cooling, the specimen gang may be reinstalled in the drill jig (Figure 1a) using .50 inch diameter pins through the previously drilled holes for alignment purposes. The six .500 inch diameter holes marked (2) may then be drilled and reamed. This procedure insures that the bonded joint of the test specimens will be perpendicular to the center line of the loading holes. Next the removal of excess adhesive flash from the edges of the panel is recommended. This may be accomplished by using a 1/16 inch or less diameter, sharp end mill to traverse along the flash, removing the excess without touching the metal surfaces. At this time the individual specimens may be cut from the specimen gang and finished individually. As part of the finishing operation, the extra 3/4" length allowed on one end for alignment holes is removed and specimens are finished to a nine inch length by one inch width prior to testing. The cutting operation should be performed so as to avoid overheating or mechanical damage to the bonded regions.

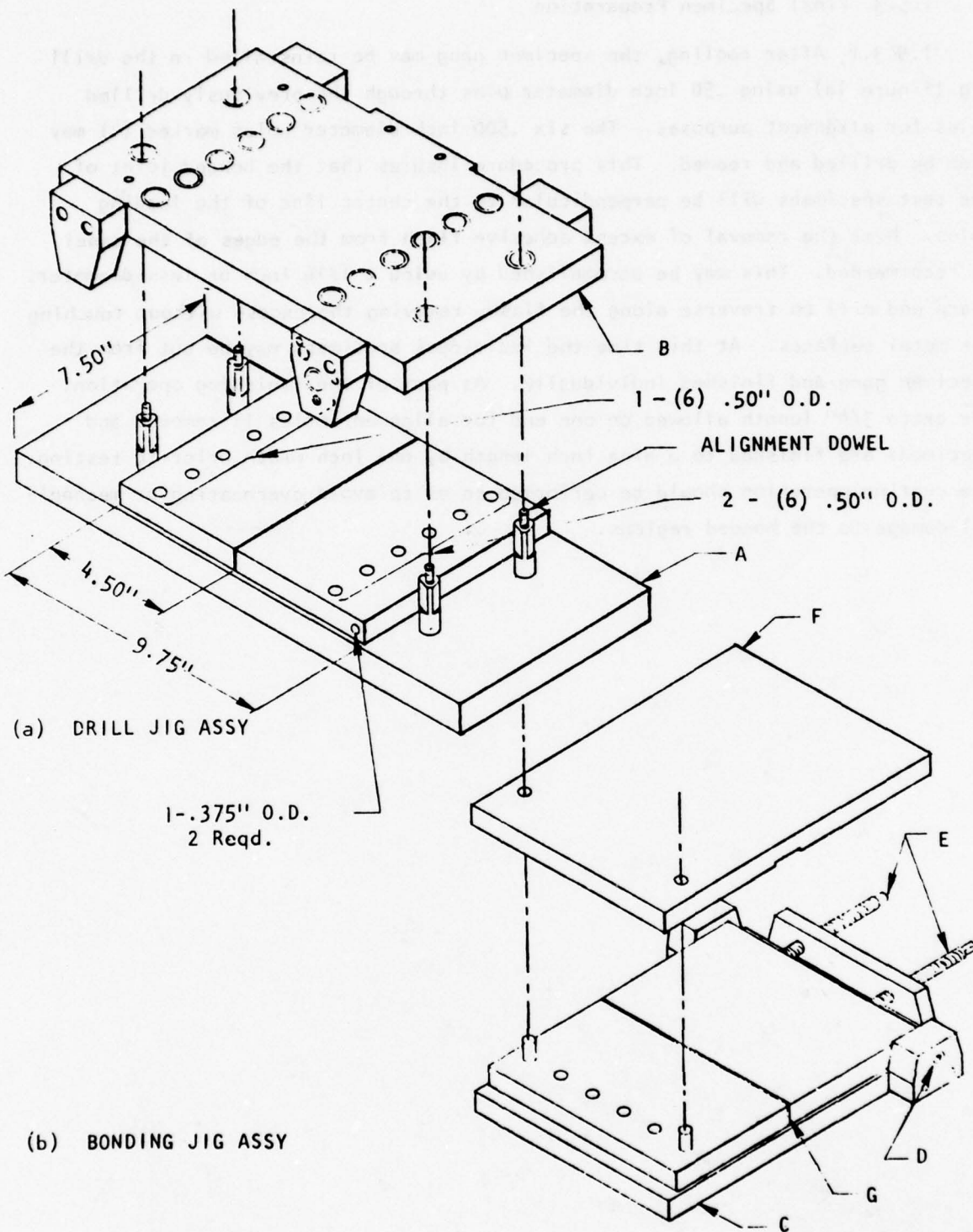

FIGURE 1. DRILL AND BONDING JIG ASSEMBLY

ATTACHMENT II

PRELIMINARY TEST SPECIFICATION FOR CHARACTERIZING THE STATIC SHEAR (TENSION) STRESS-STRAIN RESPONSE OF STRUCTURAL ADHESIVES

INTRODUCTION

The purpose of this test specification is to provide the means by which one may accurately obtain the shear or (tensile) mechanical properties of adhesives. Accuracy and repeatability of the test results will depend on the repeatability of adherend surface preparation, the bonding process, environmental conditioning of the adhesive, the physical test procedure and reduction of the test data. The thermal history of the cure process¹ has been shown to exert a dramatic effect on polymeric materials. Heat up, cool down and thermal cycling rates along with surface roughness,² air entrapment,³ pressure,⁴ adhesive thickness and overage materials are but some of the parameters that can significantly affect the reproducibility of adhesive mechanical property data. Extreme care must be maintained throughout the entire test procedure from adherend surface preparation to data reduction if reliable, reproducible results are to be obtained.

This recommended practice lists the information which should be included in reports of tests. The intention is to ensure that all useful and readily available information is transmitted to interested parties. Reports receive special attention for the following reasons: (1) results from different, recognized procedures vary significantly; therefore, identification of methods is important; (2) later studies to establish important variables are often hampered by the lack of detailed information in published reports; (3) the nature of prolonged tests often makes retest impractical, and at the same time makes difficult remaining within the recommended variations of some controlled variables. A detailed report permits transmittal of test results without implying a degree of control which was not achieved.

1. SCOPE

1.1 This test specification covers the determination of the static shear (tensile) stress-strain response of structural adhesives, for various strain rates, temperatures and relative humidities with the adhesive restrained by relatively high modulus adherends in a thin bondline.

1.2 This specification is intended to be used to develop realistic shear (tensile) mechanical properties for design of metal adherend bonded structures. Properties will include elastic shear (tensile) modulus, Note (1), proportional limit stress, ultimate shear (tensile) strain, ultimate shear (tensile) stress and the general shape of the static stress-strain response curve.

1.3 This specification can be used to evaluate environmental effects of the adhesive's shear (tensile) response if proper specimen environmental conditioning procedures are followed per Section 8.

1.4 The test specification is intended for use with metal adherends only. Its use with advanced composite materials and other non-metallic adherend materials may be applicable but much research needs to be performed to verify this.

2. DEFINITION OF TERMS

2.1 Cohesive Failure

2.1.1 Failure which occurs within the adhesive or primer itself. Failure at the adhesive-primer interface is also designated as a cohesive failure.

2.2 Adhesive Failure

2.2.1 Failure of the adhesive or primer at its interface with the metal.

2.3 Ultimate Shear (Tensile) Stress

2.3.1 The maximum applied load divided by the original bonded surface area.

2.4 Elastic Shear (Tension) Modulus

2.4.1 The ratio of the stress to strain within the elastic limit (Note 1). The strain is the adhesive displacement per unit adhesive thickness.

2.5 Proportional Limit Stress

2.5.1 The stress at which the stress-strain response becomes nonlinear.

2.6 Ultimate Shear (Tensile) Strain

2.6.1 The strain recorded for the maximum applied load.

Note 1: Since the existence of a true elastic limit in adhesives as in many other organic materials and in many metals, is debatable, the propriety of applying the term "elastic modulus" in its quoted generally accepted definition to describing the "stiffness" or "rigidity" of an adhesive has been seriously questioned. The exact stress-strain characteristics of adhesive materials are highly dependent on such factors as rate of application of stress, temperature, moisture, previous history of specimen, etc. However, stress-strain curves for adhesives determined as described in this method almost always show a linear region at low stresses, and a straight line drawn tangent to this portion of the curve permits calculation of an elastic modulus of the usually defined type. Such a constant is useful if its arbitrary nature and dependence on time, temperature and similar factors are realized.

3. TEST APPARATUS

3.1 Test Machine

3.1.1 The load shall be applied at a uniform crosshead rate throughout the duration of the test. The test machine may be electro-hydraulically controlled or mechanically driven. It must control and record the load applied to the specimen to an accuracy of ± 0.50 percent of full scale at all times. The load indicating mechanism shall be essentially free of inertial lag for all loading rates. The accuracy of the test machine shall be verified in accordance with ASTM Methods E4, Verification of Testing Machines.

3.2 Grips

3.2.1 Grips are used for holding a test specimen between the fixed member and the movable member. The grips shall be of the self-aligning type; that is, they shall be attached to the fixed and movable member, respectively, in such a way that they will move into alignment as soon as a load is applied, so that the direction of pull is parallel (at right angles for the tensile specimen) to the adhesive-interface plane. Recommended grips are shown in Figure 1. The pin holes in the grips should be parallel within $.10$ degrees and alignment in the vertical plane should be insured by moving the ram and load cell together and adjusting for any lateral eccentricity.

3.2.2 Gripping devices may oxidize, warp and creep with repeated use at elevated temperatures and relative humidities. Eccentricity and associated bending stresses may result. Therefore, grips should be periodically retested for axiality and reworked as necessary.

4. MEASUREMENT SYSTEM

4.1 Temperature and relative humidity, control and measurement instrumentation should be stable for lengthy time intervals. This is especially true when a test specimen is being moisture conditioned in a specific temperature environment. Temperature control should be within ± 1.0 degree centigrade. Relative humidity control should be within ± 3.0 percent from 0-100 degrees centigrade. Temperature measurements can be made with a calibrated thermocouple or a dry bulb thermometer. A wet bulb-dry bulb thermometer is recommended for combined temperature-moisture measurements where the relative humidity level is above 20 percent. Temperature and/or relative humidity control should be essentially constant throughout the actual physical test. Control should preferably be maintained by a suitable automatic control device. The extent of the fluctuations should be reported in the test results.

5. DEFORMATION MEASUREMENT

5.1 The intent of this specification is to insure the accurate measurement⁵ ($\pm 3.4\%$) of the shear (tensile) properties of structural adhesives. Therefore, the adhesive deformation measurement device should measure the adhesive deformation within $\pm 2\%$ of full scale to satisfy this criteria. In order to obtain this sensitivity in a stable manner for relatively long time periods, for small adhesive bondlines (i.e. gage lengths of from .002" to .020") typically encountered in bonded structures, and for a broad range of temperatures and relative humidities, a parallel-plate capacitive measurement device is recommended. This is a Class A measurement device per ASTM E-83. The capacitive measurement device should be calibrated against a precisely known capacitance and so reported in the test results. The device will measure adhesive deformation continuously for various strain rates. The attachment of the detector should be within .062 inches of the adhesive-adherend interface on the adherend at the centerline of the overlap (i.e. L_2 in Figure 2) and at $h_1/2$ in Figure 3. Correction for metal deformation should be made during the data reduction phase of the test. Slippage of either capacitance plate during the test must be avoided to prevent erroneous deformation data from tainting the test results. The capacitance measurement device is so designed that it will impose a load on the specimen of 1.2 pounds in a truly axial manner. This can be subtracted out by most test systems. The capacitance measurement device can be used in temperature extremes of from -30°F to 350°F and over the full range of relative humidities.

5.2 Once the deformation measurement device is attached, the test should begin immediately if the specimen is not maintained in its preconditioning environment. If the specimen and capacitance device are maintained in the preconditioning environment during the mechanical test, a period of 30 minutes should be allocated to allow the measurement device to stabilize in the environment before commencing the test.

5.3 Recording of the load-deformation data should be through the use of instrumentation which would not reduce the accuracy requirements below those stated in this section.

6. RECORDING SYSTEM

6.1 Selection of a system to record the output signal from the capacitance bridge is extremely important. The output signal (voltage) from the bridge of the deformation measurement device is amplified and recorded by digital or graphic means. In order to avoid reducing the accuracy of the output signal, the recording device should be linear. Moreover, the recording device should be essentially noise (i.e. jitter, drift) free so as to not impair the resolution of the output signal from the bridge of the deformation measurement device. Maintenance of these requirements is extremely important if one is to meet the overall accuracy requirements specified in Section 5.

7. TEST SPECIMENS

7.1 Specimen Fabrication

7.1.1 The test specimens are to be prepared for testing per the ATC fabrication specification entitled "Fabrication of Thick Adherend, Butt and Scarf Joint Test Specimens" (Note 2). This was presented in detail in an AFML Contract Report.⁶ Once the test specimens have been cut into approximately one inch wide test pieces, their pertinent dimensions shall be measured to the following accuracy (Figures 2,3):

- Overlap Length (L_2) - $\pm .001$ inches
- Adherend Thickness (h_1) - $\pm .0005$ inches
- Adhesive Thickness (η) - $\pm .00010$ inches
- Specimen Length (L_1) - $\pm .02$ inches
- Gap Length (L_G) - $\pm .001$ inches (thick adherend specimen only).

7.1.2 The adhesive thickness should be measured at four locations, two on each specimen side, as detailed in Figure 4. The thickness measurements should preferably be made once the adhesive-adherend interface has been properly prepared so that a distinct boundary is readily visible for optical measurements to be made. This can be done using a polishing wheel and 600 grit paper. An optical measurement device with a resolution better than 1×10^{-4} inches should be employed.

7.2 Bondline Non-Destructive Inspection

7.2.1 Non-destructive inspection of the bonded area is required to assure the fabricator that the test specimens are free from voids, air bubbles and/or imperfections. Failure to attain near defect free bonded areas will result in poor and unreliable adhesive characterization data. Ultrasonic C-scan or Neutron Radiographic means are recommended for inspection of the bonded area of the various test specimens. Proper NDI procedures are called out in the ATC fabrication specification referenced in Section 7.1.

Note 2: It is realized that a material cannot be tested without also testing the method of preparation of that material. Hence, when comparative tests of materials per se are desired, the greatest care must be exercised to ensure that all samples are prepared in exactly the same way. Similarly, for referee or comparative tests of any given series of specimens, care must be taken to secure the maximum degree of uniformity in details of preparation, treatment, and handling.

7.3 Number of Specimens/Data Point

7.3.1 It is desirable to test at least five specimens for each set of adhesive thickness, strain rate and environmental parameters.

7.3.2 Specimens that fracture prematurely due to some obvious specimen or testing procedural flaw shall be discarded and retests made.

8. ENVIRONMENTAL CONDITIONING

8.1 Scope

8.1.1 Test conditions for temperature and moisture only are specified. The duration of exposure is dependent upon the chemical nature of the adhesive, type of specimen, the temperature extreme and percent relative humidity at which conditioning is to proceed.

8.1.2 This section covers conditioning of the test specimen at constant temperature and relative humidity values only.

8.2 Preconditioning

8.2.1 Once the test specimens have been machined to their final dimensions, they shall be labeled with an identification number and dessicated for 4 days at room temperature in a dessicant (<5.0% R.H.). Upon completion of this phase, actual conditioning of the test specimens for mechanical characterization testing shall commence. A temperature, relative humidity and number of hours for the enviromental conditioning procedure shall be specified.

8.2.2 Preconditioning of bondlines in metal adherent bonded specimens can take from several days to several months, depending on the equilibrium conditions one seeks to attain. In all instances the total environmental history of the test specimens should be known and recorded.

8.2.3 All test specimens shall be conditioned until moisture and/or temperature equilibrium is attained in the bonded area, prior to the initiation of the attainment of mechanical property data.

8.2.4 Temperature and/or moisture conditioning shall be accomplished in an environmental chamber capable of maintaining the required environment within the constraints specified in Section 4.1. Readings of the temperature and relative humidity environment shall be taken a minimum of twice a day (preferably on a continuous basis) and within six inches of the specimen if circulating air is not maintained.

8.2.5 The environmental chamber shall be calibrated a minimum of every six months to verify that the chamber vs. temperature/relative humidity control device is in proper working order.

8.3 Saturated Salt Solutions

8.3.1 If a saturated salt solution (ASTM Specification E104) in a dessicator along with an oven is employed to precondition the specimens, the continuous monitoring of moisture can be maintained through the use of various hygrometric measurement devices below 140°F. A thermocouple can be used to monitor temperature in the oven. It should be placed adjacent to the bondline. Both temperature and relative humidity variation should be within the limits specified in Section 4.1. Verification that the prescribed environment is being maintained should be made at least twice a day.

8.4 Control Specimens

8.4.1 To verify that the test specimen has attained moisture equilibrium, a control specimen of the dimensions detailed in Figure 5 should be inserted in the dessicator or conditioning environment and its moisture intake measured periodically to verify that the test specimen has attained moisture equilibrium. This would be required for the initial specimens of a particular adhesive to be conditioned. After this, a predictive equation, yet to be derived, may be used to safely estimate the time required for the specimen to attain equilibrium.

8.4.2 Test and control specimens should be placed in the environmental chamber so as to not impair the bondline surfaces from the ingress of moisture.

9. TEST PROCEDURE

9.1 The specimen is to be tested in shear (tension) by tension loading after environmental equilibrium is attained or within 15 minutes upon removal of the specimen from the conditioning environment.

9.2 Grips

9.2.1 Place the specimen in the ball and socket type grips shown in Figure 1 so that the long axis of the specimen and the centerline of load pull through the grip assembly coincide.

9.3 Preloading

9.3.1 Set the recording device to the proper sensitivity to record the load vs. deformation results. Set the load range frequency and strain rate parameters to their desired values on the test machine. Attach the deformation measurement device to the specimen and calibrate all recording equipment. Preload the specimen to approximately ten percent of its expected ultimate load to align the specimen in the test fixture and eliminate any initial adhesive defects. Reduce the load to that prescribed in the next section.

9.4 Testing

9.4.1 Maintain a small bias load of 25 lbs. on the specimen to preserve all alignment in the assembly just prior to applying load. Load the test specimen to failure at the prescribed strain rate in the specified environment. Record load vs. deformation. If the elastic modulus is to be obtained from the load-deformation trace, the scale on either axis should be adjusted as required to obtain approximately a 45-60 degree trace. This improves data reduction accuracy. Test all specimens, which have been conditioned in a given environment, within as narrow a time span as feasible, to avoid environmental aging effects.

9.4 Record

- o Load-Deformation Curve
- o Data, Temperature, Relative Humidity vs. Time
- o Strain Rate
- o Pertinent Test Machine Settings

10. REPORT OF TEST RESULTS

10.1 The report format specified in Table 1 shall be used to detail the results of all specimen testing.

10.2 Calculations

10.2.1 Definition of Terms

- A_s = Surface Area of Shear Specimen (i.e. overlap length x specimen width) (in^2)
- A_A = Cross-sectional Area of Tensile Specimen (in^2)
- E_A = Apparent Uniaxial Tension Modulus of Adhesive as Measured in the Butt Joint Test (PSI)
- E = Bulk Tension Modulus of Adhesive (PSI)
- E_d = Young's Modulus of Adherend Material (PSI)
- F_{PL} = Shear Proportional Limit Stress of the Adhesive (PSI)
- F_{Su} = Adhesive Ultimate Shear Stress (PSI)
- F_{Tu} = Average Adhesive Ultimate Tensile Stress at Failure (PSI)
- G = Effective Shear Modulus of the Adhesive (PSI)
- P = Applied Load (LBS.)
- P_{PL} = Load at which the Load-Deformation Curve Departs from Linearity (LBS.)
- P_u = Maximum Load Specimen Attains (LBS.)
- S.F. = Ratio of Constant Shear Stress of Optimum Specimen to (P/A_s) Shear Stress - (See Figure 6)
- T.F. = Factor to Account for Dependence of Ratio of E_A/E on the Adhesive's Poisson's Ratio - (See Figure 7)
- ϵ = Adhesive Tensile Strain (in/in)

Δ_s = Adhesive Displacement in Shear Specimen (Inches)

Δ_L = Distance between Measurement Device Attachment Points (See Figure 3) (Inches)

Δ_T = Adhesive Displacement in Tension Specimen (Inches)

η = Adhesive Thickness (Inches)

ν_a = Poisson's Ratio of Adhesive Material

ν_d = Poisson's Ratio of Adherend Material

10.2.2 Shear Specimen

$$G = \frac{P(\eta) \text{ (S.F.)}}{A_s (\Delta_s)} \quad \text{C-1}$$

$$F_{PL} = \frac{P_{PL} \text{ (S.F.)}}{A_s} \quad \text{C-2}$$

$$F_{Su} = \frac{P_u \text{ (S.F.)}}{A_s} \quad \text{C-3}$$

For a load $P_1 > P_2$ and attachment points A & B .126" apart
 Δ_s = Displacement measured between loads P_1 and $P_2 - \frac{(P_1 - P_2)}{100} 6.7 \times 10^{-6}$

10.2.3 With reference to Figure 6, one is not sure of the ratio of E_d/G when initially calculating G. Therefore, one should enter Figure 6 assuming a value of E_d/G to obtain an initial value of S.F. to calculate (G). If the $G_{\text{calculated}}$ and G_{assumed} to enter Figure 6 are approximately equal one has the correct shear modulus. If there is a disparity, recalculate S.F. using the new value of (G). Continue this iterative scheme until $G_{\text{assumed}} = G_{\text{calculated}}$. This should occur within several iterations.

10.2.4 Tension Specimen

$$E_A = \frac{\Delta P(\eta)}{A_A \Delta_T} \quad \text{C-4}$$

$$\nu_a = \frac{2G - E_A}{2[G - E_A + 2\nu_d/E_d E_A g]} \quad \text{C-5}$$

$$E = E_A / T.F. \quad C-6$$

$$*F_{Tu} \cong \frac{E_A}{1+\nu_a} \epsilon \left(1 + \frac{\nu_a}{1-2\nu_a}\right) \quad C-7$$

$$\Delta_T = \text{Displacement Measured between loads } P_1 \text{ \& } P_2 - \frac{(P_1 - P_2)(\Delta L - \eta)}{A_A E_d} \quad C-8$$

$$\epsilon = \Delta T / \eta \quad (P_1 > P_2) \quad C-9$$

10.2.5 With the value of (ν_a) calculated per equation (C-5) one enters Figure 7 to obtain the value of T.F. so as to calculate (E) using equation (C-5).

10.2.6 Statistical Evaluation of Data

- o Mean (\bar{x}), Standard Deviation (SD) and Coefficient of Variation (CV) for the ultimate stress, ultimate strain, proportional limit stress, and elastic shear (tensile modulus) can be calculated per equations (C-9-11).

$$\bar{x} = 1/N \sum_{i=1}^N X_i \quad C-10$$

$$S.D. = \left[\sum_{i=1}^N (X_i - \bar{x})^2 / (N - 1) \right]^{1/2} \quad C-11$$

$$C.V. = S.D. / \bar{x} \quad C-12$$

where:

X_i = individual test value for each specimen

N = Number of individual specimens tested.

10.3 Precision

10.3.1 The following data should be used for judging the acceptability of results (95% confidence limits) (Note 3).

*Equation (C-6) to calculate the adhesive tensile stress becomes approximate for $\nu_a > .48$ and $G > .5 \times 10^6$ psi. the error is $\cong 5\%$.

Repeatability - Duplicate test results by an individual should be suspect if they differ by more than 3.4%.

Reproducibility - The average result reported by one laboratory should be considered suspect if it differs from that of another laboratory by more than 5%.

NOTE 3: These precision data are approximations based on limited data, but they provide a reasonable basis for judging the significance of results.

11. REFERENCES

1. Yalof, S., "Mechanical Properties, Dielectric Measurements and the Thermal History of Polymers", 20th National SAMPE Symposium and Exhibition, Volume 20, April 1975.
2. Jennings, C. W., "Surface Preparation For Adhesive Bonding". To be published in Journal of Adhesion.
3. Bascom, W. D., and Cottingham, R. L., "Air Entrapment In the Use of Structural Adhesive Films", Journal of Adhesion, Volume 4, 1972, pp. 193-209.
4. McIntyre, R. T., Duer, F. L. and Gallagher, E. A., "Effect of Varying Processing Parameters in the Fabrication of Adhesive-Bonded Structures, Part VI: Production Methods, Final Report", Picatinny Arsenal, TR No. 4162, February 1971.
5. Renton, W. J., "Structural Properties of Adhesives", Quarterly Progress Report No. 1, AFML Contract No. F33615-76-R-5205, August 1976.
6. Renton, W. J., "Structural Properties of Adhesives," Quarterly Progress Report No. 3, AFML Contract No. F33615-76-R-5205, February 1977.

TABLE 1. SUMMARY OF TEST RESULTS

1. Type of Tests - _____

2. Specimen
 I. D. _____
 Panel Loc. _____

3. Adherend Material
 Call Out - _____
 Heat Treat - _____
 Method of Manuf. - _____
 Surface Prep. - _____

4. Adhesive Material
 Manufacturer - _____
 Call Out - _____
 Batch No. _____
 Scrim _____
 Form - _____
 Chem. Comp. - _____
 Primer - _____
 Storage-Temp. _____ R. H. _____
 Time-Fab. to Use. _____
 Bond. Spec. Used - _____
 Warm Up Time _____
 Heat Up Rate _____
 Temp. _____ Press. _____ Time _____
 Cool Down Rate _____ Press. On _____

5. Instrumentation
 Accuracy _____
 (a) Load - _____
 (b) Deform. Meas. - _____
 (c) Recording - _____
 (d) Environ. Chamber _____
 Temp. _____ R.H. _____
 (e) Overall - _____

Test Specimen Info:
 L₂ _____ h₁ _____
 n (avg) _____ Range: _____
 How Adhes Thick. Read _____
 Spec. Length - _____ Width - _____
 Gap Length - _____
 Bond Area - _____
 Adhes. Spew Removed - _____
 (a) How - _____

Environmental History
 6. Dessicant Time _____ Temp _____ R.H. _____
 Cond. Environ. Time _____ Temp _____ R.H. _____
 How Cond. - _____
 Max. Varia.-Temp. _____ R.H. _____
 7. Envir. During Test Temp _____ R.H. _____
 Max. Varia. Temp. _____ R.H. _____

8. Test Results
 Strain Rate - _____
 P. L. Load - _____
 Ult. Load - _____
 Elast. Mod.-Mean _____ S.D. _____
 P. L. Stress-Mean _____ S.D. _____
 Ult. Stress-Mean _____ S.D. _____
 Type Fail- $\frac{1}{2}$ Cohes. _____ & Adhes _____
 NDI Tech. Used - _____
 Summary of - _____
 Deviations Noted in Test _____
 Fab., Cond. or Test Proceed _____
 Error Anal. - _____
 General Remarks - _____

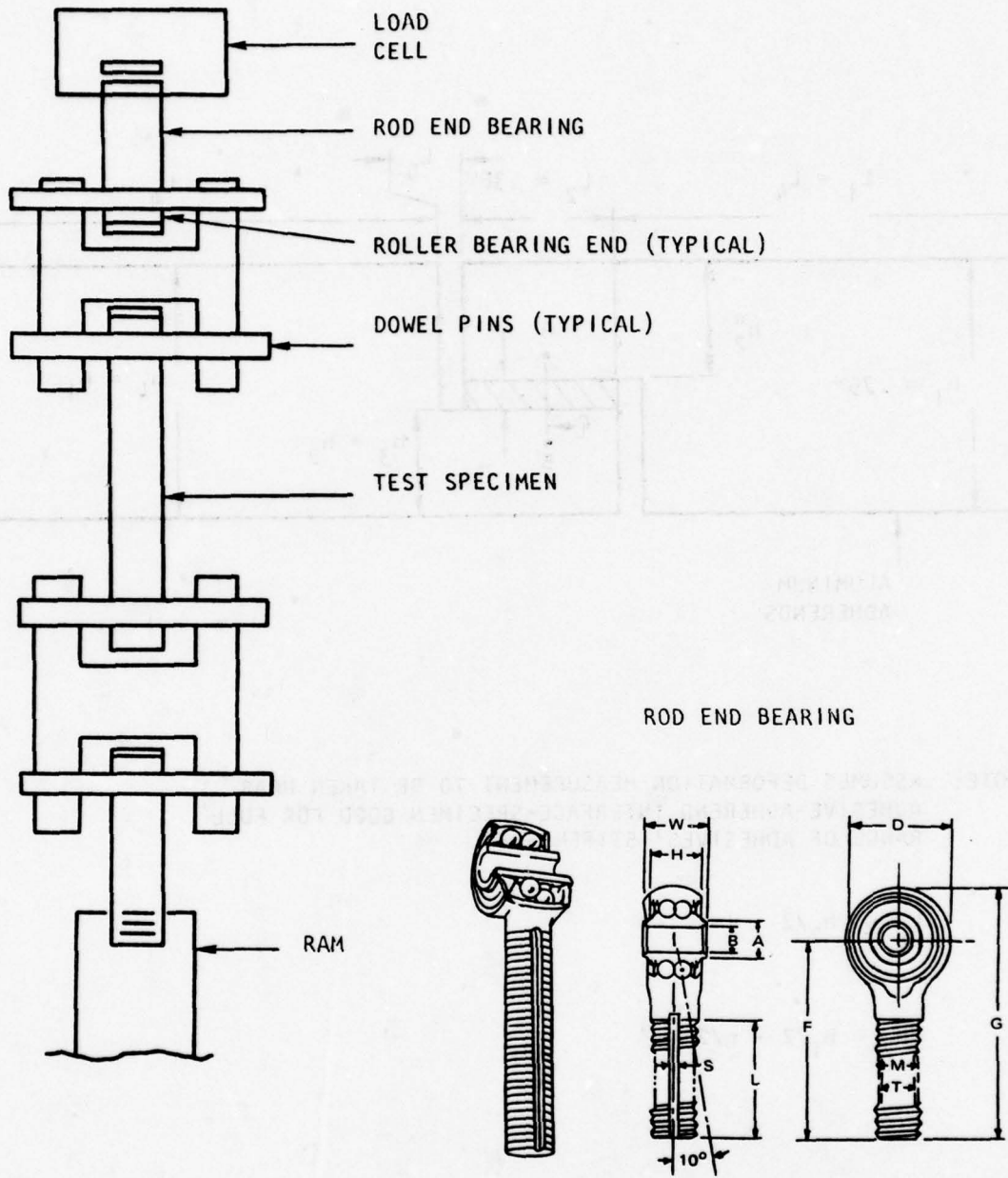
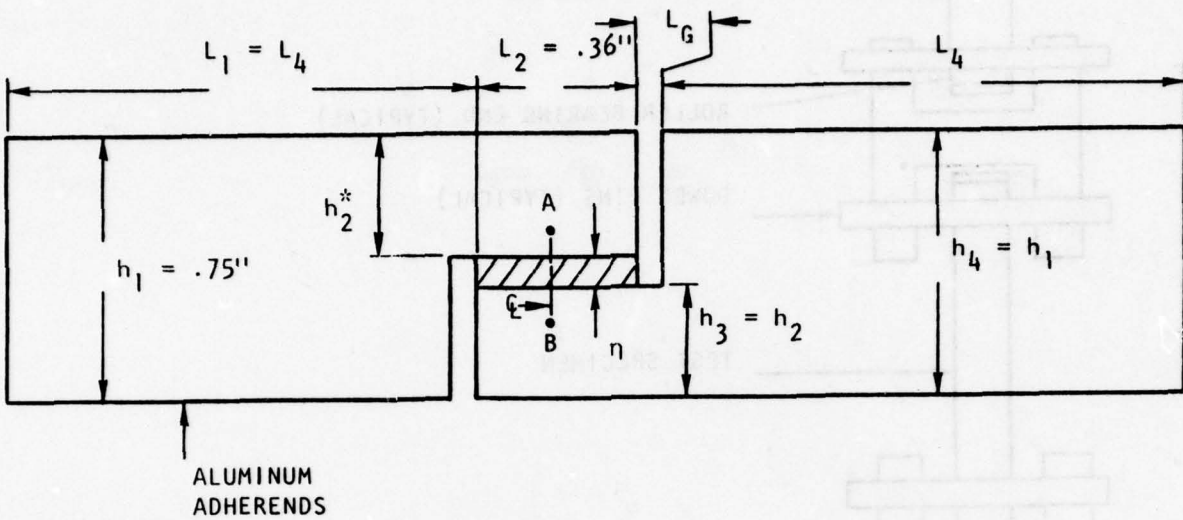

FIGURE 1. TYPICAL TENSILE TEST SETUP USING ROD END BEARINGS



NOTE: ASSUMES DEFORMATION MEASUREMENT TO BE TAKEN NEAR ADHESIVE-ADHEREND INTERFACE-SPECIMEN GOOD FOR FULL RANGE OF ADHESIVES' STIFFNESSES.

$$L_G \cong h_2/2$$

$$^*h_2 = h_1/2 - \eta/2$$

FIGURE 2 . SHEAR SPECIMEN OPTIMUM ADHESIVE TEST SPECIMEN GEOMETRY

OPTIMUM DIMENSIONS:

$$R = \frac{h_1}{\eta} \geq 40$$

$$\frac{L_2}{h_1} \geq 4$$

$$\frac{L_1}{L_2} \geq 8$$

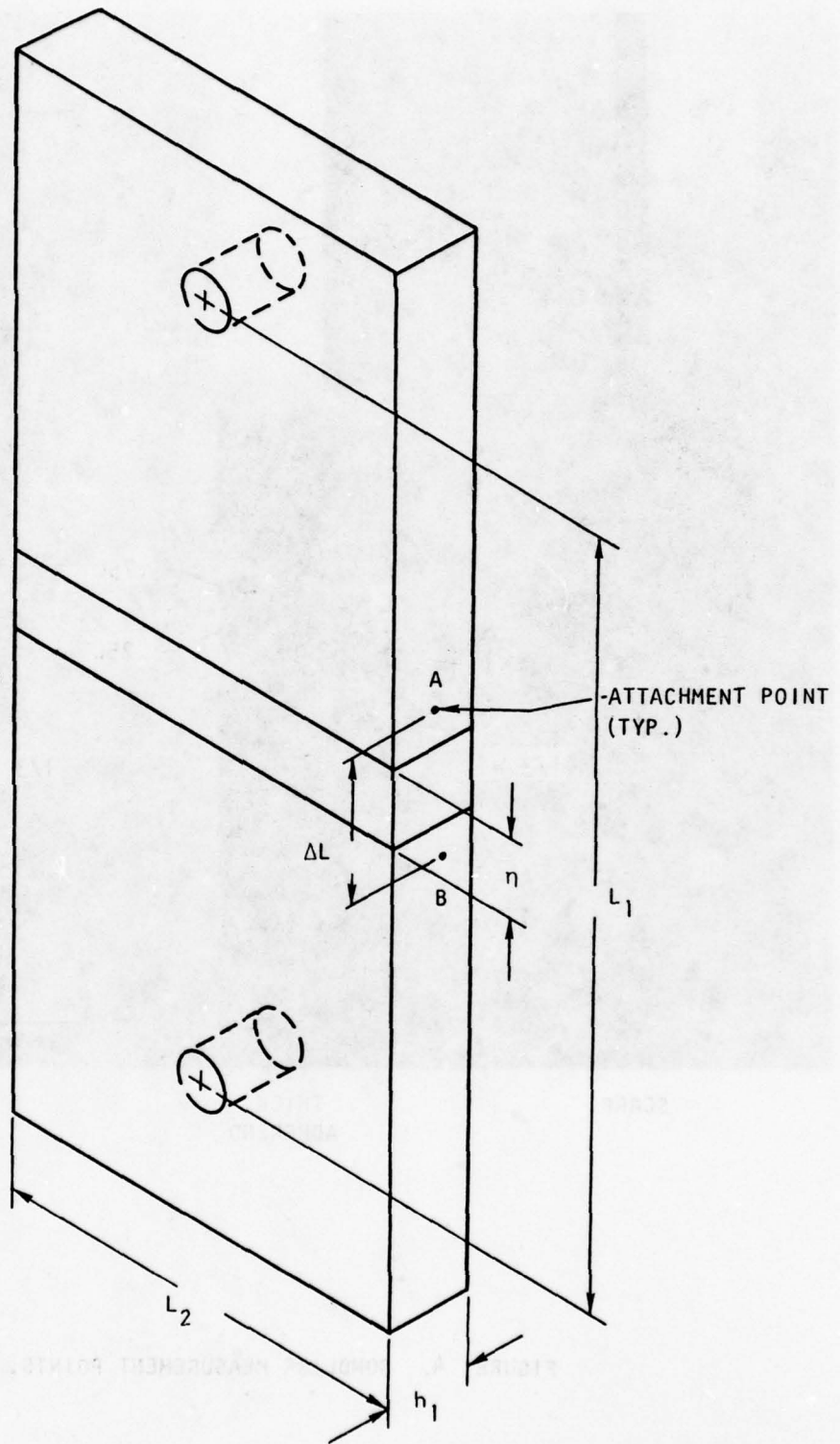
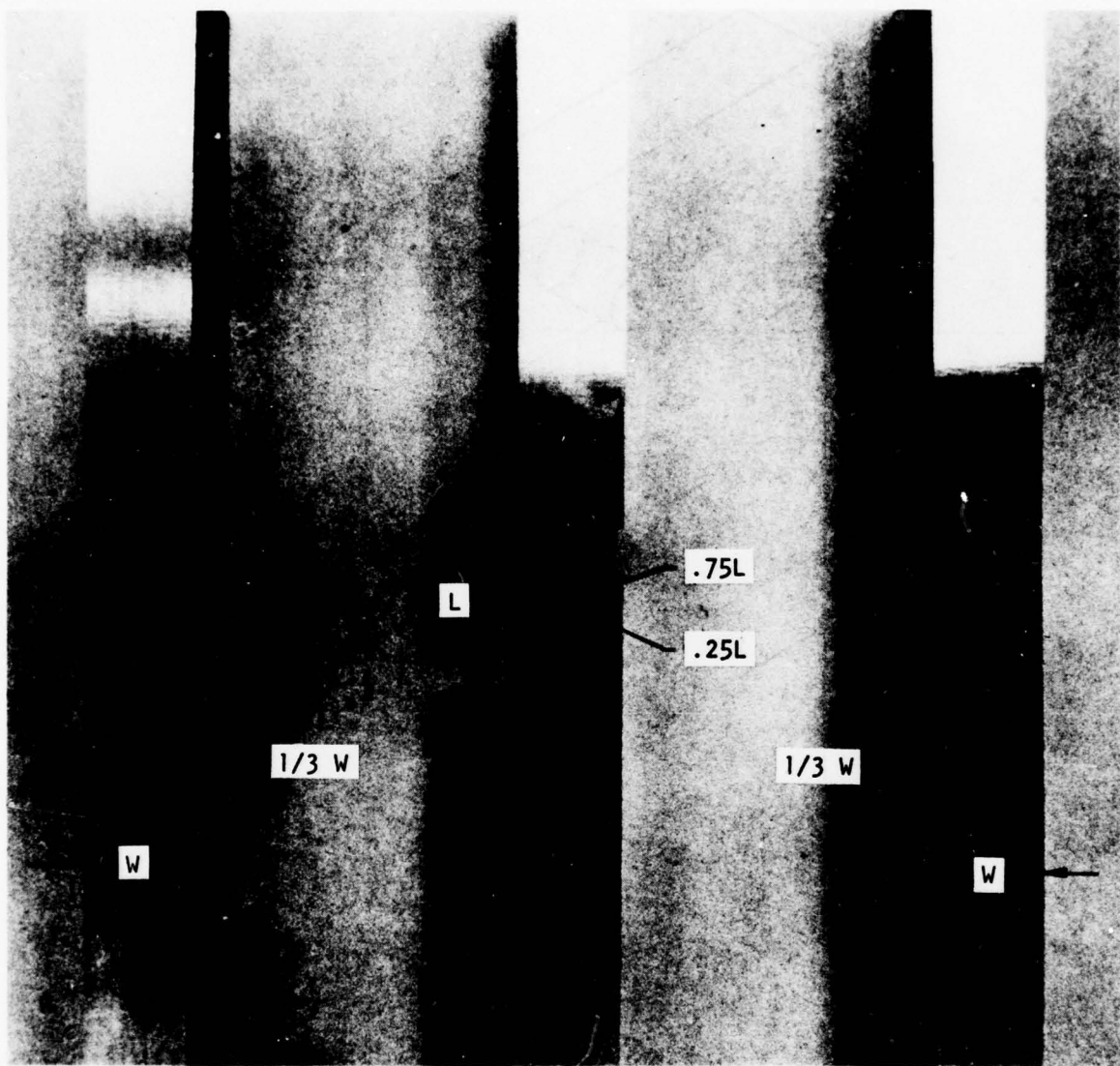

FIGURE 3. TENSILE SPECIMEN OPTIMUM ADHESIVE TEST SPECIMEN GEOMETRY.



SCARF

THICK
ADHEREND

BUTT

FIGURE 4. BONDLINE MEASUREMENT POINTS.

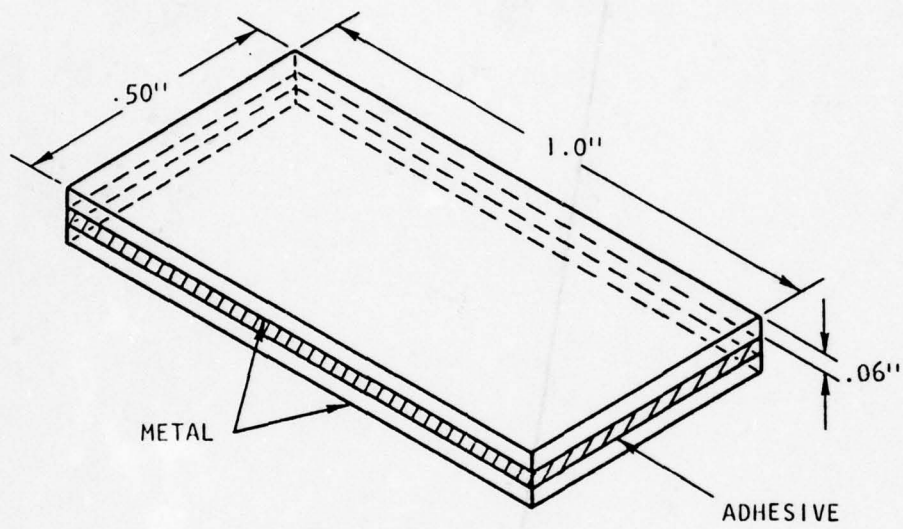

FIGURE 5. MOISTURE CONTROL SPECIMEN

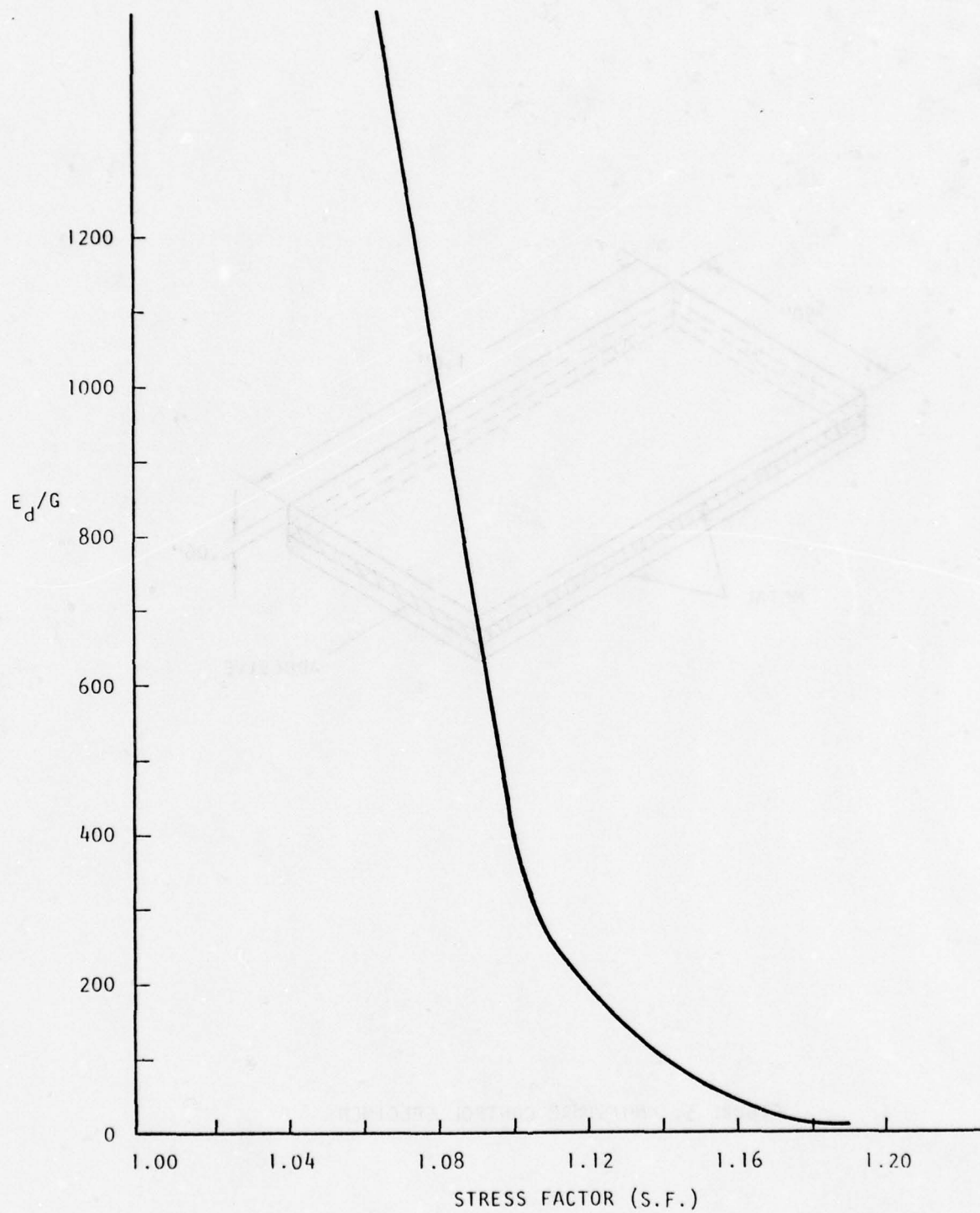

FIGURE 6. STRESS FACTOR VERSUS E_d/G

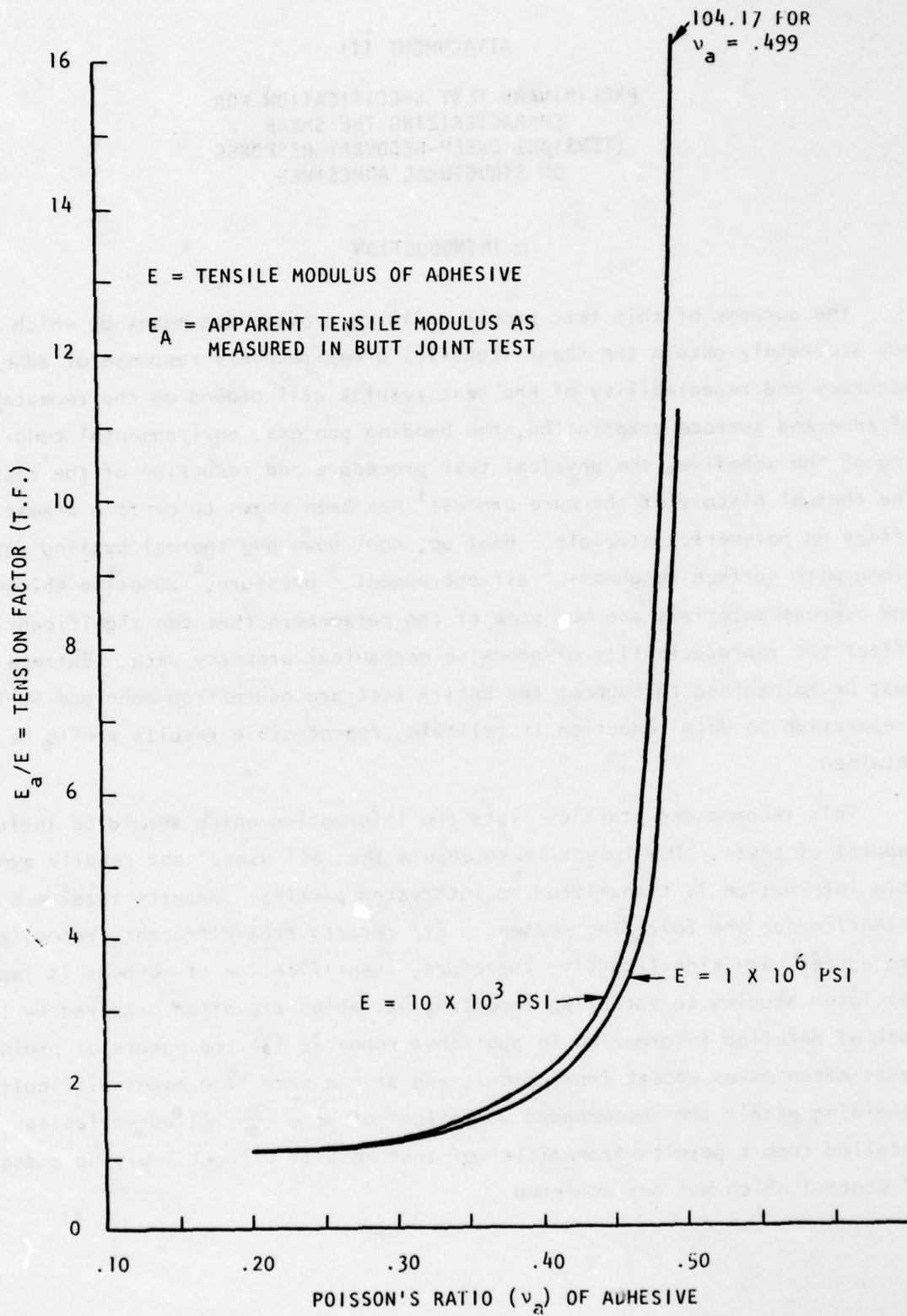

FIGURE 7. TENSILE STRESS FACTOR FOR ALUMINUM ADHERENDS ($40 \leq \text{ASPECT RATIO} \leq 80$).

ATTACHMENT III

PRELIMINARY TEST SPECIFICATION FOR CHARACTERIZING THE SHEAR (TENSION) CREEP-RECOVERY RESPONSE OF STRUCTURAL ADHESIVES

INTRODUCTION

The purpose of this test procedure is to provide the means by which one may accurately obtain the shear (tensile) creep-recovery response of adhesives. Accuracy and repeatability of the test results will depend on the repeatability of adherend surface preparation, the bonding process, environmental conditioning of the adhesive, the physical test procedure and reduction of the test data. The thermal history of the cure process¹ has been shown to exert a dramatic effect on polymeric materials. Heat up, cool down and thermal cycling rates along with surface roughness,² air entrapment,³ pressure,⁴ adhesive thickness and overage materials are but some of the parameters that can significantly affect the reproducibility of adhesive mechanical property data. Extreme care must be maintained throughout the entire test procedure from adherend surface preparation to data reduction if reliable, reproducible results are to be obtained.

This recommended practice lists the information which should be included in reports of tests. The intent is to ensure that all useful and readily available information is transmitted to interested parties. Reports receive special attention for the following reasons: (1) results from different, recognized procedures vary significantly; therefore, identification of methods is important; (2) later studies to establish important variables are often hampered by the lack of detailed information in published reports; (3) the nature of prolonged tests often makes retest impractical, and at the same time makes difficult remaining within the recommended variations of some controlled variables. A detailed report permits transmittal of test results without implying a degree of control which was not achieved.

1. SIGNIFICANCE

1.1 Data from creep tests are of considerable importance in predicting the strength of materials for resisting loads continuously applied for long times, and in predicting dimensional changes which may occur as a result of long-continued constant loads.

1.2 Data from creep tests are useful in predicting the increase in strain in materials subjected to constant stress for long times.

1.3 The test is sensitive to small changes in material composition and environmental conditions and hence is useful in evaluating the effect of such changes.

1.4 The reproducibility of the data is good when precise control is maintained over all testing conditions and material composition, including moisture content, temperature, load and effects resulting from aging.

1.5 In the application of the following test requirements and recommendations it is assumed that the test specimens of a given adhesive bond are essentially comparable and truly representative of the material. In tests conducted to show the effects of temperature, relative humidity or stress as variables, great care must be used to ensure that the specimens are representative of the adhesive bond. Departure from this assumption may introduce discrepancies as great as, if not greater than, those due to departure from details of procedure outlined in this test.

2. SCOPE

2.1 This method covers the determination of the creep-relaxation response of structural adhesives, for various temperatures and relative humidities, with the adhesive in a thin bondline, restrained by relatively high modulus adherends.

2.2 This method is intended for use in developing realistic creep-relaxation data to be used in design of adherend bonded structures. A master curve of creep-recovery compliance for various temperature and/or relative humidity parameters may be obtained by using this test procedure.

2.3 This test method is intended for use with metal adherends only. Its use with advanced composite materials and other non-metallic adherend materials may be applicable but additional research needs to be performed to verify this.

3. DEFINITION OF TERMS

3.1 Cohesive Failure

3.1.1 Failure which occurs within the adhesive or primer itself. Failure at the adhesive-primer interface is also designated as a cohesive failure.

3.2 Adhesive Failure

3.2.1 Failure of the adhesive or primer at its interface with the metal.

3.3 Total Creep Strain (Figure 6)

3.3.1 The total creep strain (ϵ_T) is the initial strain (ϵ_0) plus the transient creep strain at a particular time (t) that results from exposure to a constant load (Note 1), temperature and/or relative humidity.

3.4 Total Recovery Strain (Figure 6)

3.4.1 The total recovery strain $\epsilon_r(t)$ is the strain at time (t) following unloading of a specimen maintained at the identical constant temperature and/or relative humidity as during the creep segment of the test.

3.5 Failure

3.5.1 Rupture of the specimen, or exceeding the strain requirements of a specific design.

NOTE 1: While constant-stress tests are desirable, the usual one is a constant load test. Such a difference should have a negligible result on the test results as any change in cross-sectional area should be minimal. Creep tests made by means of spring loading or fixtures which involve deflection or strain measurements in the fixture for the application of load are satisfactory. However, if the total deformation in the adhesive is large, corrections must be made to compensate for the decrease in stress because of the extension in the adhesive.

4. TEST APPARATUS

4.1 Test Machine

4.1.1 The load shall be applied to the specimen as quickly and smoothly as feasible. The test machine may be electro-hydraulically controlled or mechanically driven but a dead weight system is preferable. It must control and record the load applied to the specimen to an accuracy of ± 0.50 percent of full scale at all times. The load indicating mechanism shall be essentially free of inertial lag following load application. The accuracy of the test machine if applicable shall be verified in accordance with ASTM Methods E4, Verification of Testing Machines.

4.1.2 The test machine shall incorporate a means of taking up the extension of the specimen so that the load will be maintained essentially constant during the creep portion of the test. The extension of the specimen should not allow the loading system to introduce eccentricity into the specimen. The take-up mechanism should avoid introducing shock loads, overloading due to friction or inertia in the loading system, or apply torque to the specimen.

4.2 Vibration Control

4.2.1 Since creep tests especially are quite sensitive to shock and vibration, select the location of the testing apparatus for a minimum of disturbance. When the possible locations are not free of vibrations, the test equipment and mounting shall be designed so that the specimen is isolated from shock and vibration.

4.3 Grips

4.3.1 Grips are used for holding a test specimen between the fixed member and the movable member. The grips shall be of the self-aligning type; that is, they shall be attached to the fixed and movable member, respectively, in such a way that they will move into alignment as soon as a load is applied, so that the direction of pull is parallel (at right angles for the tensile specimen) to the adhesive-adherend interface plane. Recommended grips are shown in Figure 1. The pin holes in the grips should be parallel within $.10$ degrees and alignment in the vertical plane should be insured by moving the ram and load cell together

and adjusting for any lateral eccentricity. Friction at the pin-grip interface should be a minimum to prevent unwanted bending to influence the test results.

4.3.2 Gripping devices may oxidize, warp and creep with repeated use at elevated temperatures and relative humidities. Eccentricity and associated bending stresses may result. Therefore, grips should be periodically retested for axially and reworked as necessary.

5. TEMPERATURE-HUMIDITY MEASUREMENT SYSTEM

5.1 The determination of the temperature and relative humidity within the test space during conditioning and the running of the test is one of the most important measurements in a creep test. Small variations in temperature and/or relative humidity may significantly affect the creep rate. A uniform temperature and relative humidity shall be maintained in the test space.

5.2 Temperature and relative humidity control and measurement instrumentation should be stable for lengthy time intervals. This is especially true when a test specimen is being moisture conditioned in a specific temperature environment. Temperature control should be within ± 1.0 degree centigrade. Relative humidity control should be within ± 3.0 percent from 0-100 degrees centigrade. Temperature measurements can be made with a calibrated thermocouple (Note 2) or a dry bulb thermometer. A wet bulb-dry bulb thermometer is recommended for combined temperature-moisture measurements where the relative humidity level is above 20 per cent. Temperature and/or relative humidity control should be essentially constant throughout the actual physical test. Control should preferably be maintained by a suitable automatic control device. The extent of the fluctuations should be reported in the test results.

NOTE 2: Such measurements are subject to two types of error. Thermocouple calibration and instrument measuring errors initially introduce uncertainty as to the exact temperature. Secondly both thermocouples and measuring instruments may be subject to variation with time. Common errors encountered in the use of thermocouples to measure temperatures include: calibration error, drift in calibration due to contamination or deterioration with use, lead-wire error, error arising from method of attachment to the specimen, direct radiation of heat to the bead, heat-conduction along thermocouple wires, etc.

6. DEFORMATION MEASUREMENT

6.1 The intent of this specification is to insure the accurate measurement⁵ ($\pm 3.4\%$) of the shear (tensile) properties of structural adhesives. Therefore, the adhesive deformation measurement device should measure the adhesive deformation within $\pm 2\%$ of full scale to satisfy this criterion. In order to obtain this sensitivity in a stable manner for relatively long time periods, for small adhesive bondlines (i.e. gage lengths of from .002" to .020") typically encountered in bonded structures, and for a broad range of temperatures and relative humidities, a parallel-plate capacitive measurement device is recommended. This is a Class A measurement device per ASTM E-83. The capacitive measurement device should be calibrated against a precisely known capacitance and so reported in the test results. The device will measure adhesive deformation continuously for various strain rates. The attachment of the detector should be within .062 inches of the adhesive-adherend interface, on the adherend, at the centerline of the overlap (i.e. L_2 in Figure 2) and at $h_1/2$ in Figure 3. Correction for metal deformation should be made during the data reduction phase of the test. Slippage of either capacitance plate during the test must be avoided to prevent erroneous deformation data from tainting the test results. The capacitance measurement device is so designed that it will impose a load on the specimen of 1.2 pounds in a truly axial manner. This can be subtracted out by most test systems. The capacitance measurement device can be used in temperature extremes of from -30°F to 350°F and over the full range of relative humidities.

6.2 Recording of the load-deformation data should be through the use of instrumentation which would not reduce the accuracy requirements below those stated in this section.

7. RECORDING SYSTEM

7.1 Selection of a system to record the output signal from the capacitance bridge is extremely important. The output signal (voltage) from the bridge of the deformation measurement device is amplified and recorded by digital or graphic means. In order to avoid reducing the accuracy of the output signal, the recording device should be linear. Moreover, the recording device should be essentially noise (i.e. jitter, drift) free so as to not impair the resolution of the output signal from the bridge of the deformation measurement device. Maintenance of these requirements is extremely important if one is to meet the overall accuracy requirements specified in Section 5.

7.2 Timing Apparatus

A suitable timing apparatus shall be employed during the temperature, relative humidity conditioning of the specimen and during the actual test so as to accurately record:

- o The time at which environmental equilibrium is attained.
- o Deformation and recovery vs. time during the creep test.

8. TEST SPECIMENS

8.1 Specimen Fabrication

8.1.1 The test specimens are to be prepared for testing per the ATC fabrication specification entitled "Fabrication of Thick Adherend, Butt and Scarf Joint Test Specimens" (Note 3). This was presented in detail in the third Quarterly Progress Report.⁶ Once the test specimens have been cut into approximately one inch wide test pieces, their pertinent dimensions shall be measured to the following accuracy (Figures 2, 3):

Overlap Length (L_2) - $\pm .001$ inches

Adherend Thickness (h_1) - $\pm .0005$ inches

Adhesive Thickness (η) - $\pm .00010$ inches

Specimen Length (L_1) - $\pm .02$ inches

Gap Length (L_G) - $\pm .001$ inches (thick adherend specimen only).

8.1.2 The adhesive thickness should be measured at four locations, two on each specimen side, as detailed in Figure 4. The thickness measurements should preferably be made once the adhesive-adherend interface has been properly prepared so that a distinct boundary is readily visible for optical measurements to be made. This can be done using a polishing wheel and 600 grit paper. An optical measurement device with a resolution better than 1×10^{-4} inches should be employed.

8.2 Bondline Non-Destructive Inspection

8.2.1 Non-destructive inspection of the bonded area is required to assure the fabricator that the test specimens are free from voids, air bubbles and/or imperfections. Failure to attain near defect free bonded areas will result in poor and unreliable adhesive characterization data. Ultrasonic C-scan or Neutron Radiographic means are recommended for inspection of the bonded area of the various test specimens.

Note 3: It is realized that a material cannot be tested without also testing the method of preparation of that material. Hence, when comparative tests of materials per se are desired, the greatest care must be exercised to ensure that all samples are prepared in exactly the same way. Similarly, for referee or comparative tests of any given series of specimens, care must be taken to secure the maximum degree of uniformity in details of preparation, treatment, and handling.

8.3 Number of Specimens/Data Point

8.3.1 Test a minimum of 3 specimens from each panel to destruction in shear (tension) for each set of adhesive thicknesses and environmental parameters to be tested for in creep. The deformation rate should be constant.

8.3.2 Test a minimum of 3 specimens in creep by shear (tension) loading for each set of adhesive thicknesses and environmental parameters. Specimens that fracture prematurely due to some obvious specimen or testing procedural flaw shall be discarded and retests made.

9. ENVIRONMENTAL CONDITIONING

9.1 Scope

9.1.1 Environmental conditioning for temperature and moisture only are specified. The duration of exposure is dependent upon the chemical nature of the adhesive, type of specimen, the temperature extreme and percent relative humidity at which conditioning is to proceed.

9.1.2 This section covers conditioning of the test specimen at constant temperature and relative humidity values only.

9.2 Preconditioning

9.2.1 Once the test specimens have been machined to their final dimensions, they shall be labeled with an identification number and dessicated for 4 days at room temperature in a dessicant (<5.0% R.H.). Upon completion of this phase, actual conditioning of the test specimens for mechanical characterization testing shall commence. A temperature, relative humidity and number of hours for the environmental conditioning procedure shall be specified.

9.2.2 Preconditioning of bondlines in metal adherend bonded specimens, with respect to moisture, can take from several days to several months, depending on the equilibrium conditions one seeks to attain. In all instances the total environmental history of the test specimens should be known and recorded.

9.2.3 All test specimens shall be conditioned until moisture and/or temperature equilibrium is attained in the bonded area, prior to the initiation of the attainment of mechanical property data.

9.2.4 Temperature and/or moisture conditioning shall be accomplished in an environmental chamber capable of maintaining the required environment within the constraints specified in Section 5.2. Readings of the temperature and relative humidity environment shall be taken a minimum of twice a day (preferably on a continuous basis) and within six inches of the specimen if circulating air is not maintained.

9.2.5 The environmental chamber shall be calibrated a minimum of every six months to verify that the chamber vs. temperature/relative humidity control device is in proper working order.

9.3 Saturated Salt Solutions

9.3.1 If a saturated salt solution (ASTM Specification E104) in a dessicator along with an oven is employed to precondition the specimens, the continuous monitoring of moisture can be maintained through the use of various hygrometric measurement devices below 140°F. A thermocouple can be used to monitor temperature in the oven. It should be placed adjacent to the bondline. Both temperature and relative humidity variation should be within the limits specified in Section 5.2. Verification that the prescribed environment is being maintained should be made at least twice a day.

9.4 Control Specimens

9.4.1 To verify that the test specimen has attained moisture equilibrium a control specimen of the dimensions detailed in Figure 5 should be inserted in the dessicator or conditioning environment and its moisture intake measured periodically to verify that the test specimen has attained moisture equilibrium. This would be required for the initial specimens of a particular adhesive to be conditioned. After this, a predictive equation may be used to safely estimate the time required for the specimen to attain equilibrium.

9.4.2 Test and control specimens should be placed in the environmental chamber so as to not impair the bondline surfaces from the ingress of moisture.

10. TEST PROCEDURE

10.1 The specimen is to be tested by subjecting it to a constant stress (load), once temperature and moisture equilibrium is attained. The load shall be applied to the specimen while it is in the controlled environment. All displacement measurements shall be taken during this time.

10.2 Static Tests

10.2.1 Static mechanical property tests at the corresponding creep test temperature, relative humidity and specimen bondline thickness shall be performed per the ATC test specification for static testing. The constant deformation rate shall be .050 in/minute. Results shall be presented per the referenced specification's recommended format.

10.3 Grips

10.3.1 Place the specimen in the ball and socket type grips shown in Figure 1 so that the specimen and the centerline of load pull, through the grip assembly, coincide. Grip the specimen firmly, 1.0 inches at each end. No slippage shall be allowed to occur throughout the test.

10.4 Preloading

10.4.1 Set the recording device to the proper scale to record the deformation vs. time results for a given load. Attach the capacitance device to the specimen and calibrate all recording equipment by preloading the specimen to 5 percent of ultimate load and then unloading to a preload of 25 pounds for seating purposes.

10.5 Linear Viscoelasticity and Multiple Cycle Effects

10.5.1 Creep and recovery tests of adhesives should be conducted for at least two cycles in order to assess any multiple cycling effects. This lack of repeatability in the creep compliance vs. time response of the material is due to residual stresses and/or flaw effects. After several cycles, the adhesive will normally respond in a repeatable manner if the load is not close to the ultimate load. This may readily be verified for a given stress level by inspection of the creep vs. time curve (Figure 6). For a linear viscoelastic material

$$\epsilon(t)/\sigma \text{ is independent of stress} \quad (1a)$$

and

$$\epsilon(t) = \epsilon(t - t') \quad (1b)$$

where t is the actual time from the initiation of the creep test and t' is the time since the stress (load) was removed from the specimen and recovery was initiated.

10.5.2 Only when the adhesive has reached a stable state (repeatable creep and recovery response) within the linear viscoelastic regime, and verified using the above two criteria (1a) and (1b), should the actual collection of creep data commence.

10.6 Length of Creep Test

10.6.1 The length of a single cycle of a creep-recovery test should last a minimum of three decades from when the initial load transients die out (≈ 1 minute) for a particular environment. This should amount to approximately sixty (20 minutes creep - 40 minutes recovery) minutes for a test cycle. An exact time, either longer or shorter than this can be ascertained from inspection of the initial test data. To obtain an accurate estimate of the exponent (N) (Section 11.2.8) a minimum of a ten percent change in strain is desirable.

10.7 Testing

10.7.1 Apply the test load quickly but gently. Avoid any sudden shock or vibration movements. Record deformation (strain) vs. time on a continuous basis until the required time has elapsed. Unload the specimen in an identical manner to which it was loaded. Again record deformation (strain) vs. time until the required time has elapsed. Repeat the cycle if desirable. Record temperature and relative humidity throughout the test. Test all specimens conditioned at the same time within as narrow a time frame as possible to avoid environmental aging effects.

10.8 Record

- o Deformation (strain) vs. time during creep and recovery
- o Time to load, unload specimen (Approx.)
- o Stress (load) level
- o Cycle number
- o Date, temperature, relative humidity vs. time

11. REPORT OF TEST RESULTS

11.1 The report format specified in Table 1 shall be used to detail the results of all specimen testing.

11.2 Calculations

11.2.1 Definition of Terms

- a_T - The time-temperature shift factor of the adhesive
- a_M - The time-relative humidity shift factor of the adhesive
- A_A - Cross-sectional area of tensile specimen (in^2)
- A_s = Surface area of shear specimen (i.e., overlap length x specimen width) (in^2)
- $D(t)$ - The time-dependent creep compliance of the adhesive (psi^{-1})
- $D_r(t)$ - The time-dependent recovery compliance of the adhesive (psi^{-1})
- E_A - Apparent uniaxial tension modulus of adhesive as measured in the butt joint test (PSI). - Obtained from tensile test (static) results.
- E_d - Young's Modulus of adherend material (PSI)
- P - Applied load (LBS)
- R - Universal gas constant
- t - Time elapsed since the initiation of the creep test
- t_1 - Time at which the recovery segment of the creep test was initiated
- S.F. = Ratio of constant shear stress of optimum specimen to (P/A_s) shear stress - obtained from static test specification and specimen analysis.
- T - Temperature $^{\circ}\text{C}$
- T_R - Arbitrary reference temperature - $^{\circ}\text{C}$
- ϵ - Adhesive tensile strain (in/in)
- ϵ_T - Adhesive creep and recovery tensile strain (in/in)
- ϵ_S - Adhesive creep and recovery shear strain (in/in)
- $\epsilon_r^{(t)}$ - The time dependent recovery strain (tension or shear) of the adhesive (See Figure 6).

- Δ_s - The time dependent displacement measured between attachment points for thick adherend specimen (see points A&B of Figure 2) by measurement device (Inches)
- ΔL - Distance between measurement device attachment points (see Figure 3) (Inches)
- Δ_T - The time dependent adhesive displacement in tension specimen (Inches)
- η - Adhesive thickness (Inches)
- ν_a - Poisson's ratio of adhesive determined from static tests at the respective temperature or relative humidity

11.2.2 General

11.2.2.1 In most instances, it is expected that the form of the creep compliance (tension or shear) relation will be:

$$\frac{\epsilon_T}{\sigma_0} = D(t) = D_0 + D_1 t^N \quad (\text{Tension}) \quad (2a)$$

$$\frac{\epsilon_S}{\sigma_0} = G(t) = G_0 + G_1 t^N \quad (\text{Shear}) \quad (2b)$$

D_0 , D_1 and N are independent of time.

11.2.2.2 The recovery compliance obtained from the creep-recovery test results, Figure 6, during which a constant stress (σ_0) was applied is defined as:

$$D_r(t) \equiv \frac{\epsilon_r(t)}{\sigma_0} \quad (3)$$

for both tension and shear tests.

11.2.2.3 For the thick adherend specimen, Figure 2, the adhesive shear stress (σ_0) is:

$$\sigma_0 = \frac{P(S.F.)}{A_s} \quad (4)$$

11.2.2.4 For the butt joint specimen, Figure 3, the adhesive tensile stress (σ_0) is:

$$\sigma_0 \cong \frac{P}{A_A} \quad (5)$$

11.2.2.5 For an isothermal and/or constant relative humidity test, $D_r(t)$ for a linear viscoelastic material, can be written as⁷:

$$D_r(t) = [(1 + \lambda)^N - \lambda^N] D_r(t_1) \quad (6)$$

$$\lambda = \frac{t - t_1}{t_1} \quad (7)$$

11.2.3 Adhesive Shear Creep-Recovery Strain

$$\epsilon_S(t) = \frac{\Delta_S(t)}{\eta} \quad (8)$$

For attachment points A & B .126" apart (see Figure 2);

$$\Delta_S(t) = \text{displacement measured} - (P/100)(6.7 \times 10^{-6}) \quad (9)$$

where the second term of the equation is the adherend correction factor.

11.2.4 Adhesive Tension Creep and Recovery Strain

$$\epsilon_T(t) = \frac{\Delta_T(t)}{\eta} \quad (10)$$

$$\Delta_T(t) = \text{Displacement measured} - \frac{P(\Delta L - \eta)}{A_A E_d} \quad (11)$$

where the second term is the adherend correction factor (See Figure 3).

11.2.5 Data Restriction

11.2.5.1 To avoid viscoelastic transient effects in the data reduction process, data recorded at times less than five times the loading (unloading) time should be disregarded. This factor may vary depending on the test machine used and adhesive one is characterizing.

11.2.6 Determination of the Time-Temperature (Time-Relative Humidity) Shift Factor

11.2.6.1 To determine the horizontal shift factors $a_T(a_M)$ plot the net creep compliance vs. log time (t) for all the constant temperature (relative-humidity) creep response data available, Figure 7. Select any one of these curves as a reference compliance for which $a_T = 1(a_M = 1)$. The horizontal distance required to superpose another curve on this reference one is equal to $\log a_T(a_M)$.

11.2.6.2 The distance $\log a_T(a_M)$ is positive when the data is to the right of the reference curve and negative when the data is to the left of the reference curve. That this is the correct sign convention can be easily checked by recognizing that a material at a temperature lower than the reference values has a smaller compliance (i.e., it is stiffer) and therefore its compliance will lie to the right of the reference one.

11.2.6.3 Once $a_T(a_M)$ vs. temperature (relative humidity) has been determined, a master compliance curve vs. reduced time (t/a_T or t/a_M) can be readily constructed, Figure 7, for multiple decades of time. This enables one to ascertain the complete rheological response of the adhesive.

11.2.7 Determination of Activation Energy of Viscous Flow

11.2.7.1 Assume the shift factor a_T has an exponential dependence with respect to the inverse of absolute temperature:

$$\log_{10} a_T = \frac{\Delta H}{2.303 R} \left(\frac{1}{T} - \frac{1}{T_R} \right) \quad (13)$$

From a plot of $\log a_T$ vs. $\frac{1}{T}$ ($^{\circ}R^{-1}$) one can use Equation (13) to estimate the activation energy (per mole) of viscous flow (ΔH). Equation (13) is valid below (T_g), the glass transition temperature.

11.2.8 Determination of (N)

11.2.8.1 The exponent (N) may be determined by plotting Equation (6) on a log-log scale for several values of N (typically $0 < N < .5$) and then overlaying these curves on a plot of the experimental recovery data (i.e., $\log D_r(t)$ vs. $\log \lambda$) to select the (N) valued curve which best fits all of the recovery compliance data. The value of (N) determined should be independent of stress, and in most cases will be independent of temperature and relative humidity below the T_g of the adhesive.

11.2.9 Determination of the Coefficients D_0 and D_1

11.2.9.1 Select any two points ($D(t)$, t) from the creep data. Substitute this data into Equation (2a) to yield two simultaneous equations in the unknowns D_0 and D_1 . Solve for D_0 , D_1 .

11.2.10 Check on the Values D_0 , D_1 , N .

11.2.10.1 One may readily check the accuracy of the values of D_0 , D_1 and N obtained by plotting

$$D(t) - D_0 = D_1 t^N \quad (12)$$

on a log-log scale. The result should be a straight line of slope (N) with a value of D_1 at $t = 1$.

11.2.11 Determination of the Constants D_0 and D_1 vs. Temperature and/or Relative Humidity

11.2.11.1 The temperature and/or relative humidity dependence of D_0 and D_1 can be obtained in a manner identical to that of Section 11.2.9. This presumes that one has creep-recovery data for various constant temperature and/or relative humidity values.

11.2.11.2 The dependence of D_0 and D_1 on temperature and/or relative humidity should be presented in graphical form for easy interpretation.

11.2.12 Relaxation Moduli

11.2.12.1 The relaxation moduli for tension and shear can be approximated as

$$E_M(t) \approx \frac{\sin M\pi}{d(t)M\pi} \quad (14)$$

where $M = \frac{d \log D(t)}{d \log(t)}$

$$G_M(t) \approx \frac{1}{2(1 + \nu_a) D(t)} \quad (15)$$

11.2.13 Statistical Evaluation of Data

o Mean (\bar{x}), Standard Deviation (SD) and Coefficient of Variation (CV) for the creep compliance and the constants D_0 , D_1 and N can be calculated per equations (16-18).

$$\bar{x} = 1/N \sum_{i=1}^N X_i \quad (16)$$

$$\text{S.D.} = \left[\sum_{i=1}^N (X_i - \bar{x})^2 / (N - 1) \right]^{1/2} \quad (17)$$

$$\text{C.V.} = \text{S.D.} / \bar{x} \quad (18)$$

where:

X_i = Individual test value for each specimen

N = Number of individual specimens tested.

11.3 Precision

11.3.1 The following data should be used for judging the acceptability of results (95% confidence limits) (Note 4).

Repeatability - Duplicate test results by an individual should be considered suspect if they differ by more than 5% for creep and 10% for recovery data.

Reproducibility - The average result reported by one laboratory should be considered suspect if it differs from that of another laboratory by more than 5% for creep and 10% for recovery data.

NOTE 4: These precision data are approximations based on limited data, but they provide a reasonable basis for judging the significance of results.

12. REFERENCES

1. Yalof, S., "Mechanical Properties, Dielectric Measurements and the Thermal History of Polymers", 20th National SAMPE Symposium and Exhibition, Volume 20, April 1975.
2. Jennings, C. W., "Surface Preparation For Adhesive Bonding". To be published in Journal of Adhesion.
3. Bascom, W. D., and Cottingham, R. L., "Air Entrapment in the Use of Structural Adhesive Films", Journal of Adhesion, Volume 4, 1972, pp. 193-209.
4. McIntyre, R. T., Duer, F. L. and Gallagher, E. A., "Effect of Varying Processing Parameters in the Fabrication of Adhesive-Bonded Structures, Part VI: Production Methods, Final Report", Picatinny Arsenal, TR. No. 4162, February 1971.
5. Renton, W. J., "Structural Properties of Adhesives", Quarterly Progress Report No. 1, AFML Contract No. F33615-76-R-5205, August 1976.
6. Renton, W. J., "Structural Properties of Adhesives," Quarterly Progress Report No. 3, AFML Contract No. F33615-R-5205, August 1977.
7. Beckwith, S. W., "Viscoelastic Characterization of a Nonlinear, Glass/Epoxy Composite Including the Effects of Damage," Texas A&M Report No. MM 2895-74-8, October 1974.

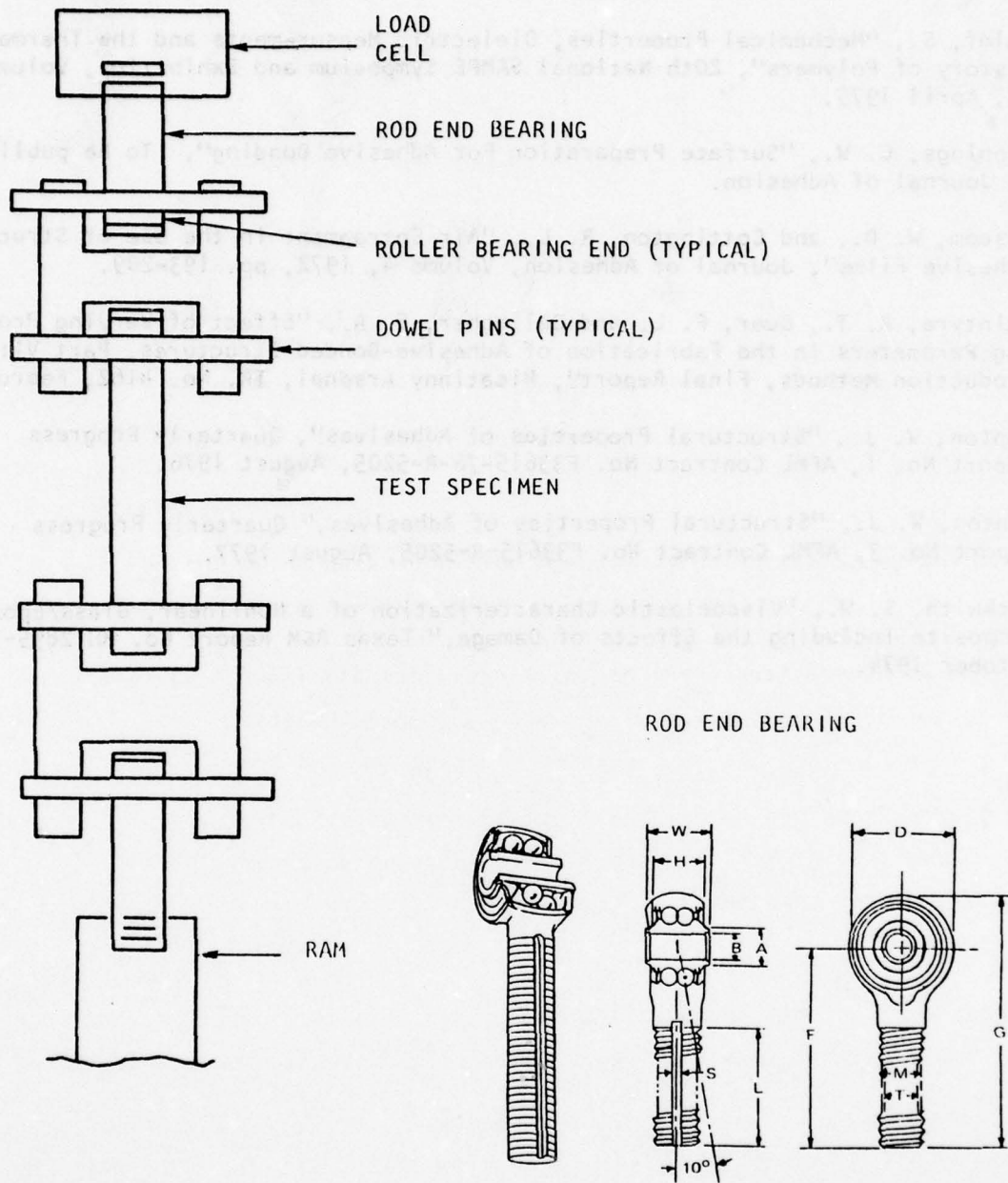
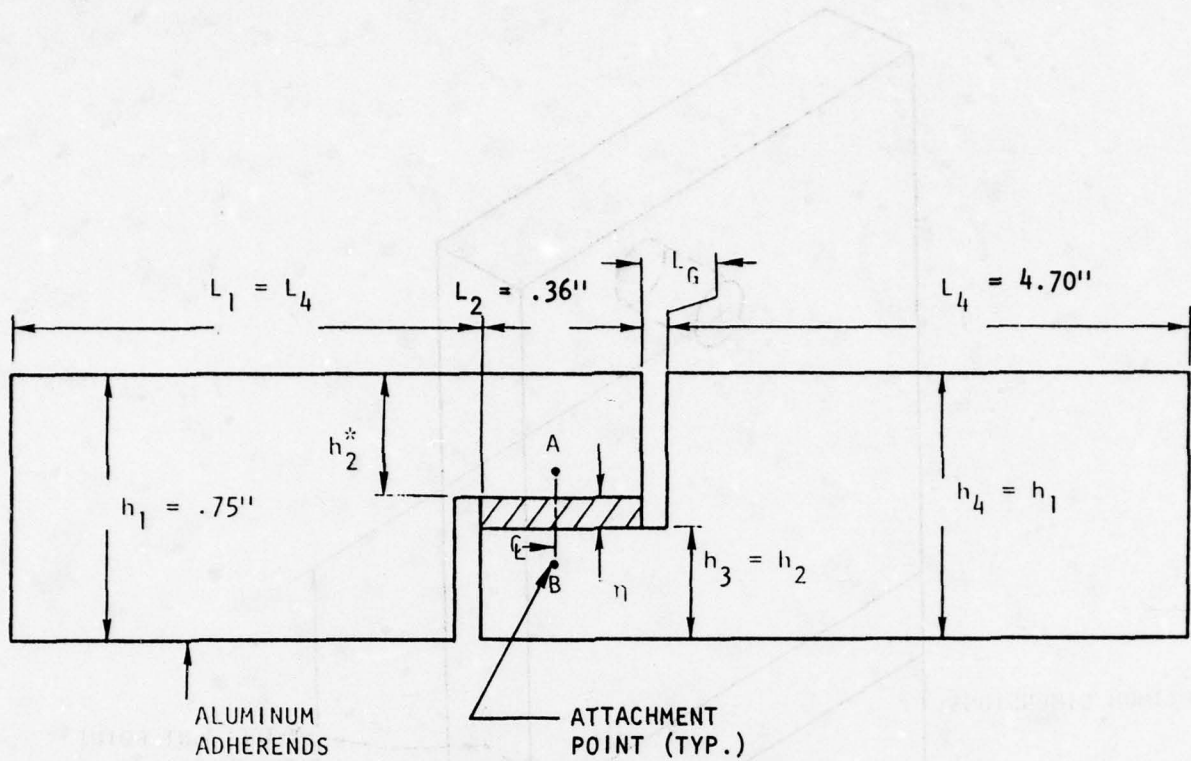

FIGURE 1. TYPICAL TENSILE TEST SETUP USING ROD END BEARINGS



NOTE: ASSUMES DEFORMATION MEASUREMENT TO BE TAKEN NEAR ADHESIVE-ADHEREND INTERFACE-SPECIMEN GOOD FOR FULL RANGE OF ADHESIVES' STIFFNESSES.

$$L_G \cong h_2/2$$

$$^*h_2 = h_1/2 - \eta/2$$

FIGURE 2. SHEAR SPECIMEN OPTIMUM ADHESIVE TEST SPECIMEN GEOMETRY

OPTIMUM DIMENSIONS:

$$\frac{h_1}{\eta} \geq 40$$

$$\frac{L_2}{h_1} \geq 4$$

$$\frac{L_1}{L_2} \geq 8$$

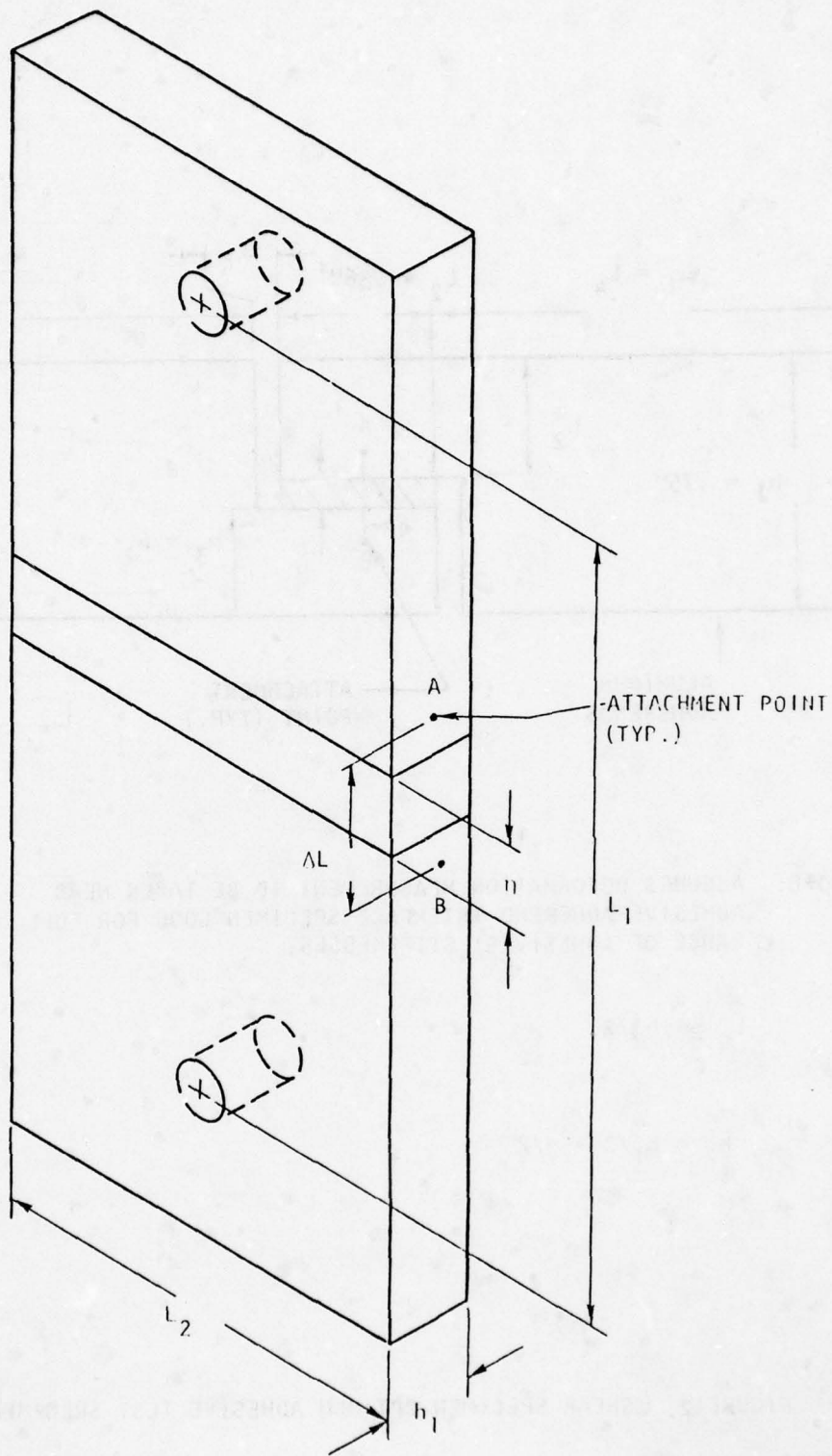
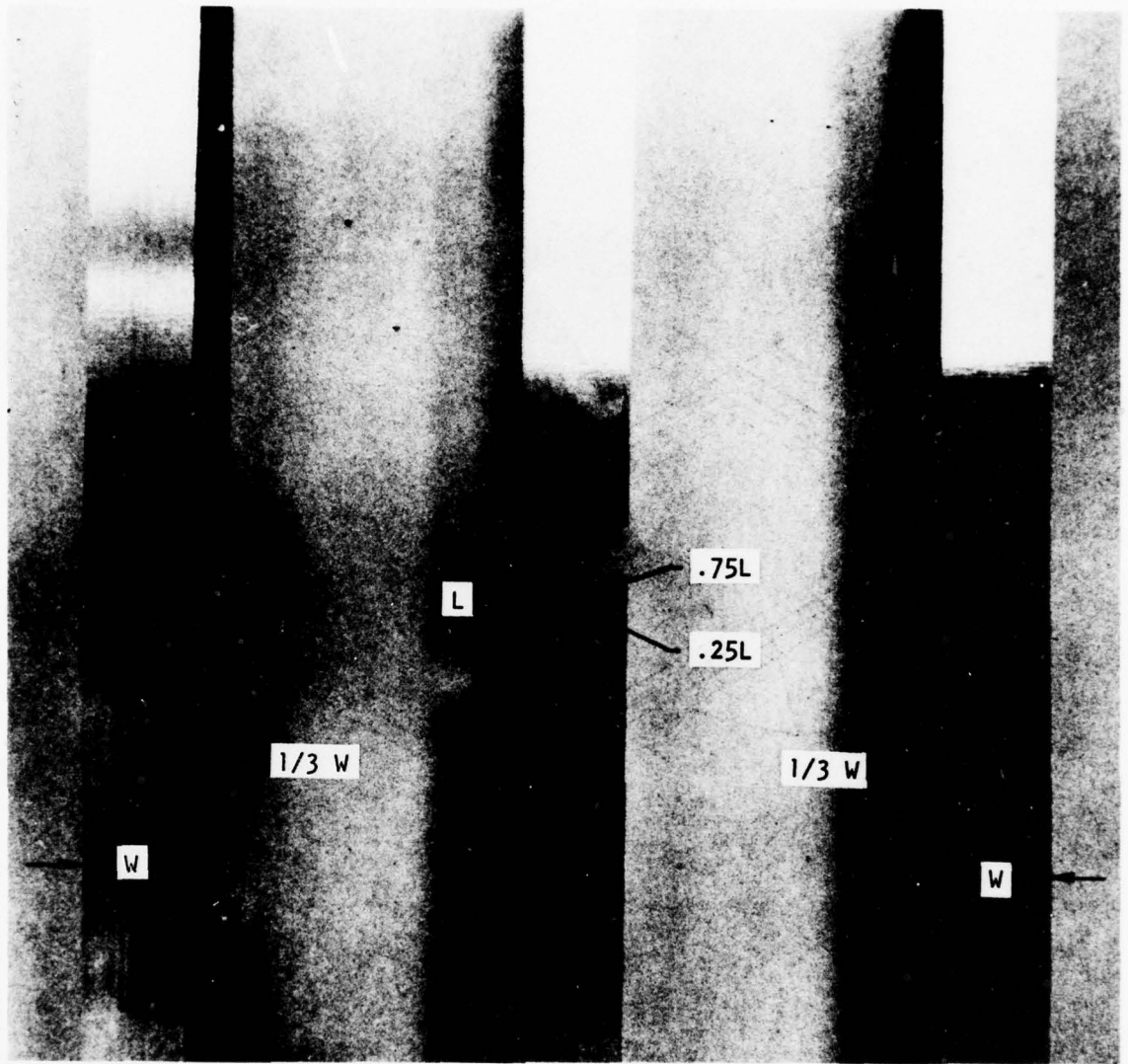

FIGURE 3. TENSILE SPECIMEN OPTIMUM ADHESIVE TEST SPECIMEN GEOMETRY.



SCARF

THICK
ADHEREND

BUTT

FIGURE 4. BONDLINE MEASUREMENT POINTS.

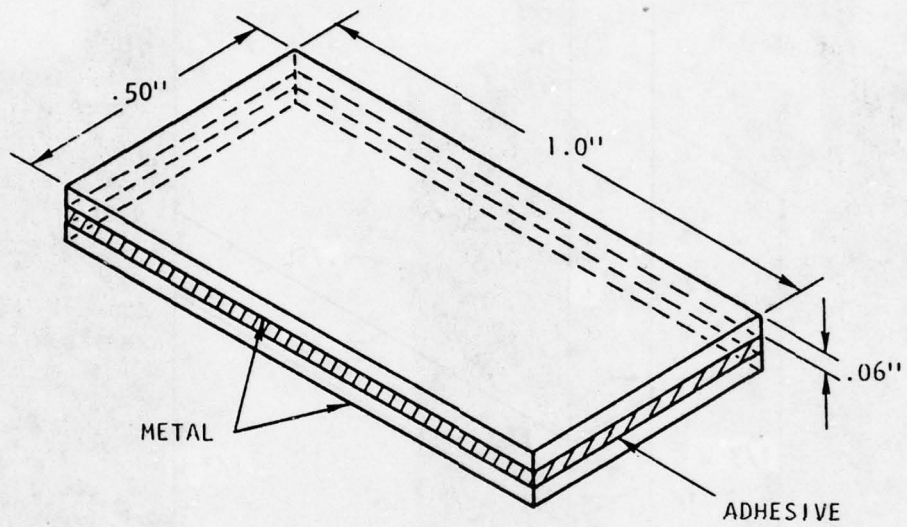

FIGURE 5. MOISTURE CONTROL SPECIMEN

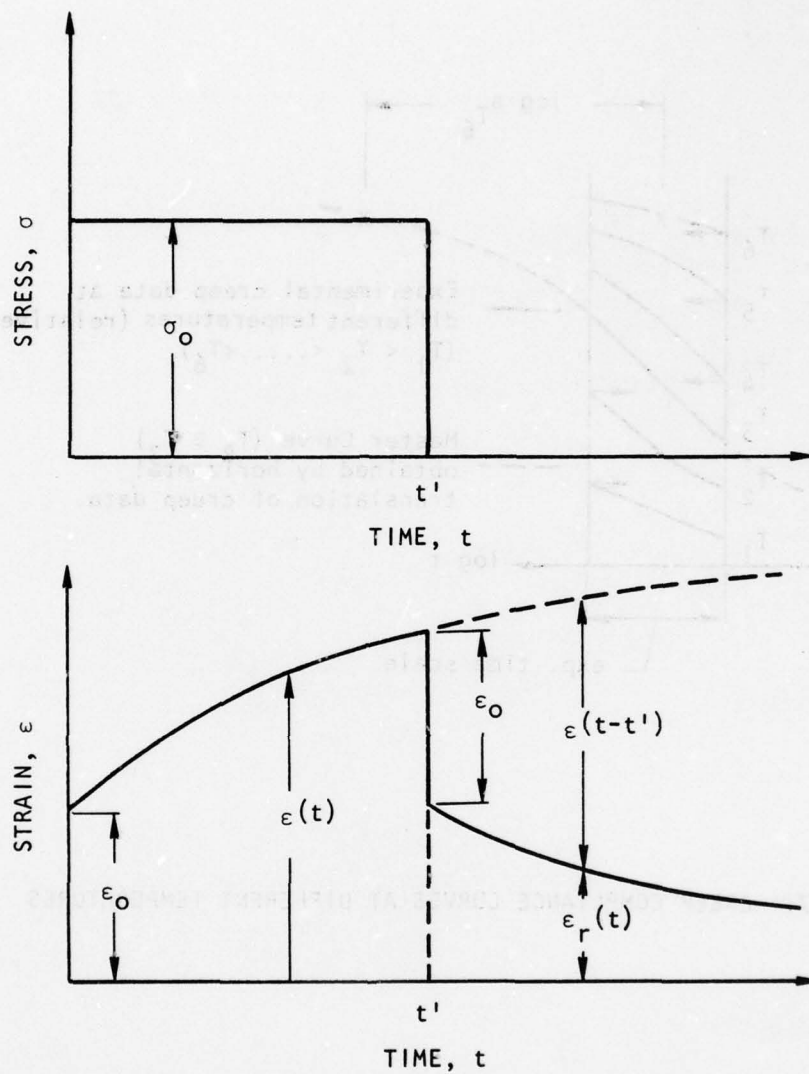

FIGURE 6. RELATION BETWEEN CREEP AND RECOVERY OF A LINEAR VISCOELASTIC MATERIAL

AD-A065 521

VOUGHT CORP ADVANCED TECHNOLOGY CENTER INC DALLAS TEX F/G 11/1
STRUCTURAL PROPERTIES OF ADHESIVES. VOLUME II. APPENDICES. A. T--ETC(U)
SEP 78 W J RENTON F33615-76-C-5205

UNCLASSIFIED

ATC-2-53500/8CRL-96

AFML-TR-78-127-VOL-2-APP-A NL

2 OF 2

AD
A065521



END
DATE
FILMED

5--79

DDC

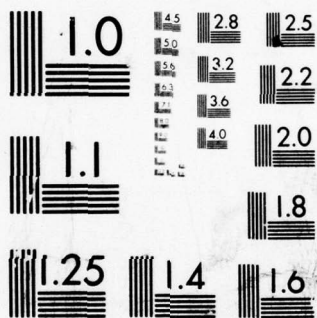

MICROCOPY RESOLUTION TEST CHART
NATIONAL BUREAU OF STANDARDS-1963-A

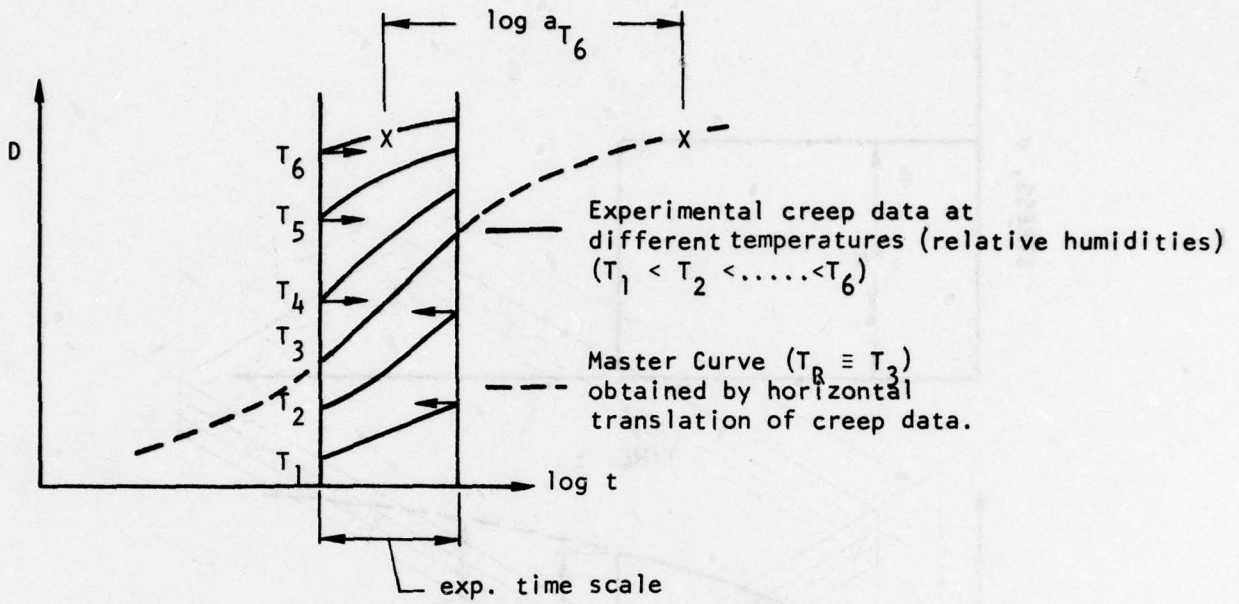

FIGURE 7. CREEP COMPLIANCE CURVES AT DIFFERENT TEMPERATURES

TABLE 1. SUMMARY OF TEST RESULTS.

1. Type of Tests - _____

2. Specimen
 I. D. _____
 Panel Loc. _____

3. Adherend Material
 Call Out - _____
 Heat Treat - _____
 Method of Manuf. - _____
 Surface Prep. - _____

4. Adhesive Material
 Manufacturer - _____
 Call Out - _____
 Batch No. _____
 Scrim _____
 Form - _____
 Chem. Comp. - _____
 Primer - _____
 Storage-Temp. _____ R. H. _____
 Time-Fab. to Use. _____
 Bond. Spec. Used - _____
 Warm Up Time _____
 Heat Up Rate _____
 Temp. _____ Press. _____ Time _____
 Cool Down Rate _____ Press. On _____

5. Instrumentation
 Accuracy
 (a) Load - _____
 (b) Deform. Meas. - _____
 (c) Recording - _____
 (d) Environ. Chamber
 Temp. _____ R. H. _____
 (e) Overall - _____

6. Test Specimen Info:
 L₂ _____ h₁ _____
 n(avg) _____ Range: _____
 How Adhes Thick. Read _____
 Spec. Length ~ Width - _____
 Gap Length - _____
 Bond Area - _____
 Adhes. Spew Removed - _____
 (a) How - _____

7. Environmental History
 Date of Equipment Calibration _____
 Type of Temp., R.H. Measuring Equipment _____
 Dessiccant Time _____ Temp _____ R.H. _____
 Cond. Environ. Time _____ Temp _____ R.H. _____
 How Cond. - _____
 Max. Varia.-Temp. _____ R.H. _____
 Envir. During Test Temp _____ R.H. _____
 Max. Varia. Temp. _____ R.H. _____

8. Test Results
 Instantaneous Strain - _____
 Instantaneous Recovery - _____
 Load Level - _____
 Time to Load _____; Unload _____
 Max. Deformation-Mean _____ S.D. _____
 D₀ = _____; D₁ = _____; N = _____; ΔH = _____
 Ult. Stress-Mean _____ S.D. _____
 Ult. Strain-Mean _____ S.D. _____
 Type Fail.-% Cohes. _____ % Adhes
 Duration of Creep Test - _____
 Duration of Recovery Test - _____
 NDI Tech. Used - _____
 Summary of - _____
 Deviations Noted in Test
 Fab., Cond. or Test Proceed. _____
 Error Anal. - _____

General Remarks - Attach plots of creep-recovery results in log-log coordinates of deformation vs. time.

ATTACHMENT IV

PRELIMINARY TEST SPECIFICATION FOR CHARACTERIZING THE SHEAR (TENSION) FATIGUE STRESS-STRAIN RESPONSE OF STRUCTURAL ADHESIVES

INTRODUCTION

The purpose of this test procedure is to provide for the determination of the tensile and shear fatigue stress-strain response of structural adhesives. The data is to be used in fatigue design of load bearing bonded assemblies.

Adhesives fail in fatigue. They do so, in analogy with more well-studied metals, because of a cycle by cycle accumulation of damage resulting from repeated non-elastic strain. This strain can further be influenced by frequency of loading, temperature, humidity and time (viscoelastic) effects. After a sufficient number of stress (strain) applications numerous micro-cracks form, grow incrementally and eventually propagate in an unstable manner, resulting in specimen failure. Fatigue failure should, therefore, be given serious consideration in the design of structural bonded components.

One of the items required in the design process is the stress-strain behavior of the adhesive during its lifetime at a prescribed fatigue load, frequency and in a controlled environment. From such data master curves can be constructed to ascertain the fatigue stress-strain relationship for a particular adhesive for a definite strain ratio and various combinations of environment and frequency of load application. This test procedure outlines the methodology by which one can obtain the required mechanical characterization of the adhesive.

The accuracy and repeatability of the test results will depend on the repeatability of adherend surface preparation, the bonding process, environmental conditioning of the adhesive, the physical test procedure and reduction of the test data. The thermal history of the cure process¹ has been shown to exert a dramatic effect on polymeric materials. Heat up, cool down and thermal cycling rates along with surface roughness,² air entrapment,³ pressure,⁴ adhesive thickness and overage materials are but some of the parameters that can significantly affect the reproducibility of adhesive mechanical property data. Extreme care must be maintained throughout the entire test procedure from adherend surface preparation to data reduction if reliable, reproducible results are to be obtained.

This recommended practice lists the information which should be included in reports of tests. The intention is to ensure that all useful and readily available information is transmitted to interested parties. Reports receive special attention for the following reasons: (1) results from different, recognized procedures vary significantly; therefore, identification of methods is important; (2) later studies to establish important variables are often hampered by the lack of detailed information in published reports; (3) the nature of prolonged tests often makes retest impractical, and at the same time makes difficult remaining within the recommended variations of some controlled variables. A detailed report permits transmittal of test results without implying a degree of control which was not achieved.

1. SCOPE

1.1 This method covers the determination of the fatigue shear and tension stress-strain response of structural adhesives, for various strain ratios, temperatures, relative humidities and frequencies, with the adhesive restrained by relatively high modulus adherends in a thin bondline.

1.2 This method is intended to be used to develop the shear and tension stress-strain response of adhesives for design of metal adherend bonded structures. Properties obtained will include apparent shear (tension) modulus, maximum strain vs. cycles to failure and the general shape of the fatigue stress-strain response curve.

1.3 This method can be used to evaluate environmental effects of the adhesive's shear and tensile response if proper specimen environmental conditioning procedures are followed per Section 8.

1.4 The test method is intended for use with metal adherends only. It's use with advanced composite materials and other non-metallic adherend materials may be applicable but much research needs to be performed to verify this.

2. DEFINITION OF TERMS

2.1 Cohesive Failure

2.1.1 Failure which occurs within the adhesive or primer itself. Failure at the adhesive-primer interface is also designated as a cohesive failure.

2.2 Adhesive Failure

2.2.1 Failure of the adhesive or primer at its interface with the metal.

2.3 Apparent Modulus

2.3.1 The ratio of the stress to strain at a given location on the fatigue stress-strain curve. The strain is the adhesive displacement per unit adhesive thickness.

3. TEST APPARATUS

3.1 Test Machine

3.1.1 The test machine shall be capable of applying a sinusoidal cyclic tensile load. The test machine may be electro-hydraulically controlled or mechanically driven. It must control and record the load applied to the specimen to an accuracy of $\pm .50$ percent of full scale at all times. The load indicating mechanism shall be essentially free of inertial lag for all loading rates. The accuracy of the test machine shall be verified in accordance with ASTM Methods E4, Verification of Testing Machines. The cyclic rate and type of control (load or strain) can influence test results. Therefore the cycle rate and mode of control shall be specified when reporting the test results. A low cycle rate (2-4 Hz) is recommended to obtain mechanical property data not unduly influenced by heat buildup (hysteresis) within the specimen.

3.2 Grips

3.2.1 Grips are used for holding a test specimen between the fixed member and the movable member. The grips shall be of the self-aligning type; that is, they shall be attached to the fixed and movable member, respectively, in such a way that they will move into alignment as soon as a load is applied, so that the direction of pull is parallel (perpendicular for the tension test) to the adhesive-adherend interface plane. Recommended grips are shown in Figure 1. The pin holes in the grips should be parallel within .10 degrees and alignment in the vertical plane should be insured by moving the ram and load cell together and adjusting for any lateral eccentricity.

3.2.2 Gripping devices may oxidize, warp and creep with repeated use at elevated temperatures and relative humidities. Eccentricity and associated bending stresses may result. Therefore, grips should be periodically retested for axiality and reworked as necessary.

4. ENVIRONMENTAL MEASUREMENT SYSTEM

4.1 Temperature and relative humidity, control and measurement instrumentation should be stable for lengthy time intervals. This is especially true when a test specimen is being moisture conditioned in a specific temperature environment. Temperature control should be within ± 1.0 degree centigrade. Relative humidity control should be within ± 3.0 percent from 0-100 degrees centigrade. Temperature measurements can be made with a calibrated thermocouple or a dry bulb thermometer. A wet bulb-dry bulb thermometer is recommended for combined temperature-moisture measurements where the relative humidity level is above 20 per cent. Temperature and/or relative humidity control should be essentially constant throughout the actual physical test. Control should preferably be maintained by a suitable automatic control device. The extent of the fluctuations should be reported in the test results.

5. DEFORMATION MEASUREMENT

5.1 The intent of this specification is to insure the accurate measurement⁵ ($\pm 3.4\%$) of the fatigue properties of structural adhesives. Therefore, the adhesive deformation measurement device should measure the adhesive deformation within $\pm 2\%$ full scale to satisfy this criteria. In order to obtain this sensitivity in a stable manner for relatively long time periods, for small adhesive bondlines (i.e. gage lengths of from .002" to .020") typically encountered in bonded structures, and for a broad range of temperatures and relative humidities, a parallel-plate capacitive measurement device is recommended. This is a Class A measurement device per ASTM E-83. This capacitive measurement device should be calibrated against a precisely known capacitance and so reported in the test results. The device will measure adhesive deformation continuously for various strain rates. The attachment of the detector should be within .062 inches of the adhesive-adherend interface on the adherend at the centerline of the overlap (i.e. L_2 in Figure 2) and at $h_1/2$ in Figure 3. Correction for metal deformation should be made during the data reduction phase of the test. Slippage of either capacitance plate during the test must be avoided to prevent erroneous deformation data from tainting the test results. The capacitance measurement device is so designed that it will impose a load on the specimen of 1.2 pounds in a truly axial manner. This can be subtracted out by most test systems. The capacitance measurement device can be used in temperature extremes of from -30°F to 350°F and over the full range of relative humidities.

5.2 The specimen and capacitance device are to be maintained in the pre-conditioning environment during the mechanical test. A period of 30 minutes should be allocated to allow the measurement device to stabilize in the environment before commencing the test.

5.3 Recording of the load-deformation data should be through the use of instrumentation which would not reduce the accuracy requirements below those stated in this section.

6. RECORDING SYSTEM

6.1 Selection of a system to record the output signal from the capacitance bridge is extremely important. The output signal (voltage) from the bridge of the deformation measurement device is subsequently amplified and recorded by digital or graphic means. In order to avoid reducing the accuracy of the output signal, the recording device should be linear. Moreover, the recording device should be essentially noise (i.e. jitter, drift) free so as to not impair the resolution of the output signal from the bridge of the deformation measurement device. Maintenance of these requirements is extremely important if one is to meet the overall accuracy requirements specified in Section 5.

7. TEST SPECIMENS

7.1 Specimen Fabrication

7.1.1 The test specimens are to be prepared for testing per the ATC fabrication specification entitled "Fabrication of Thick Adherend, Butt and Scarf Joint Test Specimens" (Note 2). This was presented in detail in an AFML Contract Report.⁷ Once the test specimens have been cut into approximately one inch wide test pieces, their pertinent dimensions shall be measured to the following accuracy (Figures 2, 3):

Overlap Length (L_2) - $\pm .001$ inches

Adherend Thickness (h_1) - $\pm .0005$ inches

Adhesive Thickness (η) - $\pm .00010$ inches

Specimen Length (L_1) - $\pm .02$ inches

Gap Length (L_G) - $\pm .001$ inches (thick adherend specimen only).

7.1.2 The adhesive thickness should be measured at four locations, two on each specimen side, as detailed in Figure 4. The thickness measurements should preferably be made once the adhesive-adherend interface has been properly prepared so that a distinct boundary is readily visible for optical measurements to be made. This can be done using a polishing wheel and 600 grit paper. An optical measurement device with a resolution better than 1×10^{-4} inches should be employed.

7.2 Bondline Non-Destructive Inspection

7.2.1 Non-destructive inspection of the bonded area is required to assure the fabricator that the test specimens are free from voids, air bubbles and/or imperfections. Failure to attain near defect free bonded areas will result in poor and unreliable adhesive characterization data. Ultrasonic C-scan or Neutron Radiographic means are recommended for inspection of the bonded area of the various test specimens. Proper NDI procedures are called out in the ATC fabrication specification referenced in Section 7.1.

Note 2: It is realized that a material cannot be tested without also testing the method of preparation of that material. Hence, when comparative tests of materials per se are desired, the greatest care must be exercised to ensure that all samples are prepared in exactly the same way. Similarly, for referee or comparative tests of any given series of specimens, care must be taken to secure the maximum degree of uniformity in details of preparation, treatment, and handling.

7.3 Number of Specimens/Data Point

7.3.1 It is desirable to test at least five specimens for each set of adhesive thickness, strain rate and environmental parameters.

7.3.2 Specimens that fracture prematurely due to some obvious specimen or testing procedural flaw shall be discarded and retests made.

8. ENVIRONMENTAL CONDITIONING

8.1 Scope

8.1.1 Test conditions for temperature and moisture only are specified. The duration of exposure is dependent upon the chemical nature of the adhesive, the type of specimen, the temperature extreme and percent relative humidity at which conditioning is to proceed.

8.1.2 This section covers conditioning of the test specimen at constant temperature and relative humidity values only.

8.2 Preconditioning

8.2.1 Once the test specimens have been machined to their final dimensions, they shall be labeled with an identification number and dessicated for 4 days at room temperature in a dessicant (<5.0% R.H.). Upon completion of this phase, actual conditioning of the test specimens for mechanical characterization testing shall commence. A temperature, relative humidity and number of hours for the environmental conditioning procedure shall be specified.

8.2.2 Preconditioning of bondlines in metal adherend bonded specimens can take from several days to several months, depending on the equilibrium conditions one seeks to attain. In all instances the total environmental history of the test specimens should be known and recorded.

8.2.3 All test specimens shall be conditioned until moisture and/or temperature equilibrium is attained in the bonded area, prior to the initiation of the attainment of mechanical property data.

8.2.4 Temperature and/or moisture conditioning shall be accomplished in an environmental chamber capable of maintaining the required environment within the constraints specified in Section 4. Readings of the temperature and relative humidity environment shall be taken a minimum of twice a day (preferably on a continuous basis) and within six inches of the specimen if circulating air is not maintained.

8.2.6 The environmental chamber shall be calibrated a minimum of every six months to verify that the chamber vs. temperature/relative humidity control device is in proper working order.

8.3 Saturated Salt Solutions

8.3.1 If a saturated salt solution (ASTM Specification E104) in a dessicator along with an oven is employed to precondition the specimens, the continuous monitoring of moisture can be maintained through the use of various hygrometric measurement devices below 140°F. A thermocouple can be used to monitor temperature in the oven. It should be placed adjacent to the bondline. Both temperature and relative humidity variation should be within the limits specified in Section 4. Verification that the prescribed environment is being maintained should be made at least twice a day.

8.4 Control Specimens

8.4.1 To verify that the test specimen has attained moisture equilibrium, a control specimen of the dimensions detailed in Figure (5) should be inserted in the dessicator or conditioning environment and its moisture intake measured periodically to verify that the test specimen has attained moisture equilibrium. This would be required for the initial specimens of a particular adhesive to be conditioned. After this, a predictive equation, yet to be derived, may be used to safely estimate the time required for the specimen to attain equilibrium.

8.4.2 Test and control specimens should be placed in the environmental chamber so as to not impair the bondline surfaces from the ingress of moisture.

9. TEST PROCEDURE

9.1 The specimen is to be tested in shear (thick adherend) or tension (butt joint) by tension loading after environmental equilibrium is attained. The test is to proceed within the environment at which equilibrium was attained.

9.2 Grips

9.2.1 Place the specimen in the ball and socket type grips shown in Figure 1 so that the long axis of the specimen and the centerline of load pull through the grip assembly coincide.

9.3 Preloading

9.3.1 Set the recording device to the proper sensitivity to record the load vs. deformation results. Set the cyclic frequency and maximum strain range parameters to their desired values on the test machine. Attach the deformation measurement device to the specimen and calibrate all recording equipment. Preload the specimen to approximately ten percent of its expected ultimate load to align the specimen in the test fixture and eliminate any initial adhesive defects. Reduce the load to approximately 25 lbs. to preserve alignment in the assembly until the prescribed sinusoidal load is applied.

9.4 Testing

9.4.1 Apply a constant uniaxial tensile strain ratio to the specimen with the test machine in the strain control mode. The maximum strain for a particular strain ratio should be less than the ultimate strain of the material. The cyclic frequency and environment should be kept constant throughout the test. Because of the high mechanical damping and low thermal conductivity of most adhesives a relatively low value of cycle frequency (2 - 4 Hz) is recommended.

9.4.2 Test five specimens each, at five or more maximum strain levels, maintaining the strain ratio, cyclic frequency and test environment at constant values for each strain level. The maximum strain values shall be selected such that failures occur with somewhat regular spacing over a cycles to failure range of several thousand to 4,000,000.

9.4.3 Record, the maximum strain, cyclic frequency, strain ratio, cycles to failure and date. Continually monitor and record the test chambers environment and the stress (load) vs. time response of the adhesive for the particular maximum strain.

10. REPORT OF TEST RESULTS

10.1 The report shall include those items specified in Table 1.

10.2 Present a composite of the test results by plotting the average adhesive shear (tensile) stress (just prior to failure) vs. maximum strain, stress-strain curve analogous to a monotonic stress-strain curve. Also plot maximum strain vs. life cycles to failure from the test results.

10.3 Present a plot of pertinent changes in the cyclic hysteresis loop vs. its location in the life of the test. The hysteresis loop can discern the percentage of the deformation process that is elastic, anelastic or plastic. The area enclosed by the hysteresis loop indicates the energy dissipated as a fraction of the total energy input per cycle ($\Delta E/E$). It's enlargement in width will signify a heat buildup within the material and significant damage being done. The maximum width of the cyclic hysteresis loop is an approximate indicator of the damaging strain per cycle.

10.4 Calculations

10.4.1 Definition of Terms

A_s = Surface Area of Shear Specimen (i.e. overlap length x specimen width) (in^2).

A_A = Cross-Sectional Area of Tensile Specimen (in^2)

E_A = Apparent Uniaxial Tension Modulus of Adhesive as Measured in the Butt Joint Test for a Particular Maximum Strain, Strain Ratio, Cyclic Frequency and Environment (PSI).

E = Bulk Tension Modulus of Adhesive for a Particular Maximum Strain, Strain Ratio, Cyclic Frequency and Environment (PSI).

E_d = Young's Modulus of Adherend Material (PSI)

F_s = Average Adhesive Shear Stress for a Particular Maximum Strain, Strain Ratio, Cyclic Frequency and Environment (PSI).

- F_T = Average Adhesive Tensile Stress for a Particular Maximum Strain, Strain Ratio, Cyclic Frequency and Environment (PSI).
- G = Effective Shear Modulus of the Adhesive at a Particular Point on the Fatigue Stress-Strain Curve for a Given Strain Ratio, Cyclic Frequency and Environment (PSI).
- P = Maximum Applied Load Prior to Specimen Failure For a Particular Maximum Strain Level (Lbs.)
- S. F. = Ratio of Constant Shear Stress of Optimum Specimen to (P/A_s) Shear Stress - (See Figure 6).
- T. F. = Factor to Account for Dependence of the Ratio of E_A/E On The Adhesive's Poisson's Ratio. (See Figure 7).
- Δ_s = Adhesive Displacement in Shear Specimen (Inches).
- Δ_L = Distance Between Measurement Device Attachment Points (See Figure 3) (Inches)
- Δ_T = Adhesive Displacement in Tension Specimen (Inches)
- ϵ = Applied Maximum Strain (in/in)
- η = Adhesive Thickness (Inches)
- ν_a = Poisson's Ratio of Adhesive
- ν_d = Poisson's Ratio of Adherend Material.

10.4.2 Shear Specimen

$$G = \frac{P(\eta)(S.F.)}{A_s(\Delta_s)} \quad (12)$$

$$F_s = \frac{P(S.F.)}{A_s} \quad (13)$$

For a load P and attachment points A & B .126" apart

$$\Delta_s = \text{Displacement measured at load } P - \frac{(P)}{100} (6.7 \times 10^{-6})$$

10.4.3 With reference to Figure 6, one is not sure of the ratio of E_d/G when initially calculating G, therefore, one should enter Figure 6 assuming a value of E_d/G to obtain an initial value of S.F. to calculate (G). If the $G_{\text{calculated}}$ and G_{assumed} to enter Figure 6 are approximately equal one has the correct shear modulus. If there is a disparity, recalculate S. F. using the new value of (G). Continue this iterative scheme until $G_{\text{assumed}} = G_{\text{calculated}}$. This should occur within several iterations.

10.4.4 Tension Specimen

$$E_A = \frac{\Delta P(\eta)}{A_A \Delta_T} \quad (14)$$

$$\nu_a = \frac{2G - E_A}{2[G - E_A + \frac{2\nu_d}{E_d} E_A G]} \quad (15)$$

$$E = E_A / T. F. \quad (16)$$

$$T.F. = \frac{E_A}{1 + \nu_a} \epsilon \left(1 + \frac{\nu_a}{1 - 2\nu_a} \right) \quad (17)$$

$$T = \text{Displacement Measured @ } P - \frac{P(\Delta L - \eta)}{A_A E_d} \quad (18)$$

$$\epsilon = \Delta_T / \eta \quad (19)$$

10.4.5 With the value of (ν_a) calculated per Equation (15) one enters Figure 7 to obtain the value of T. F. so as to calculate (E) using Equation (16).

10.4.6 Statistical Evaluation of Data

- o Mean (\bar{x}), Standard Deviation (SD) and Coefficient of Variation (CV) for the average stress, and shear (tensile) modulus can be calculated per Equations (19-21).

$$\bar{x} = 1/N \sum_{i=1}^N x_i \quad (20)$$

$$S. D. = \left[\sum_{i=1}^N (X_i - \bar{x})^2 / (N - 1) \right]^{1/2} \quad (21)$$

$$C. V. = S. D. / \bar{X} \quad (22)$$

where:

X_i = Individual test value for each specimen

N = Number of individual specimens tested.

11. REFERENCES

1. Yalof, S., "Mechanical Properties, Dielectric Measurements and the Thermal History of Polymers", 20th National SAMPE Symposium and Exhibition, Volume 20, April 1975.
2. Jennings, C. W., "Surface Preparation For Adhesive Bonding". To be published in Journal of Adhesion.
3. Bascom, W. D., and Cottingham, R. L., "Air Entrapment In The Use of Structural Adhesive Films", Journal of Adhesion, Volume 4, 1972, pp. 193-209.
4. McIntyre, R. T., Duer, F. L. and Gallagher, E. A., "Effect of Varying Processing Parameters in the Fabrication of Adhesive-Bonded Structures, Part VI: Production Methods, Final Report", Picatinny Arsenal, TR No. 4162, February 1971.
5. Renton, W. J., "Structural Properties of Adhesives", Quarterly Progress Report No. 1, AFML Contract No. F33615-76-R-5205, August 1976.
6. Rabinowitz, S. and Beardmore, P., "Cyclic Deformation and Fracture of Polymers", Journal of Materials Science, Vol. 9, 1974, pp. 81-99.
7. Renton, W. J., "Structural Properties of Adhesives," Quarterly Progress Report No. 3, AFML Contract No. F33615-76-R-5205, February 1977.

TABLE I. SUMMARY OF TEST RESULTS.

1. Type of Tests - _____

2. Specimen
 I. D. _____
 Panel Loc. _____

3. Adherent Material
 Call Out - _____
 Heat Treat - _____
 Method of Manuf. - _____
 Surface Prep. - _____

4. Adhesive Material
 Manufacturer - _____
 Call Out - _____
 Batch No. _____
 Scrim _____
 Form - _____
 Chem. Comp. - _____
 Primer - _____
 Storage-Temp. _____ R. H. _____
 Time-Fab. to Use. _____
 Bond. Spec. Used - _____
 Warm Up Time _____
 Heat Up Rate _____
 Temp. _____ Press. _____ Time² _____
 Cool Down Rate _____ Press. On _____

5. Instrumentation
Accuracy
 (a) Load - _____
 (b) Deform. Meas. - _____
 (c) Recording - _____
 (d) Environ. Chamber
 Temp. _____ R.H. _____
 (e) Overall - _____

6. Test Specimen Info:
 L₂ _____ h₁ _____
 n(avg) _____ Range: _____
 How Adhes Thick. Read _____
 Spec. Length - Width - _____
 Gap Length - _____
 Bond Area - _____
 Adhes. Spew Removed - _____
 (a) How - _____

7. Environmental History
Date of Equipment Calibration
 Type of Temp., R.H. Measuring Equipment
 Dessiccant Time _____ Temp _____ R.H. _____
 Cond. Environ. Time _____ Temp _____ R.H. _____
 How Cond. - _____
 Max. Varia.-Temp. _____ R.H. _____
 Envir. During Test Temp _____ R.H. _____
 Max. Varia. Temp. _____ R.H. _____

8. Test Results
 Instantaneous Strain - _____
 Instantaneous Recovery - _____
 Load Level - _____
 Time to Load _____; Unload _____
 Max. Deformation-Mean _____ S.D. _____
 D₀ = _____; D₁ = _____; N = _____; ΔH = _____
 Ult. Stress-Mean _____ S.D. _____
 Ult. Strain-Mean _____ S.D. _____
 Type Fail.-% Cohes. _____ & Adhes. _____
 Duration of Creep Test - _____
 Duration of Recovery Test - _____
 NDI Tech. Used - _____
 Summary of - _____
 Deviations Noted in Test
 Fab., Cond. or Test Proceed. _____
 Error Anal. - _____

General Remarks - Attach plots of creep-recovery results in log-log coordinates of deformation vs. time.

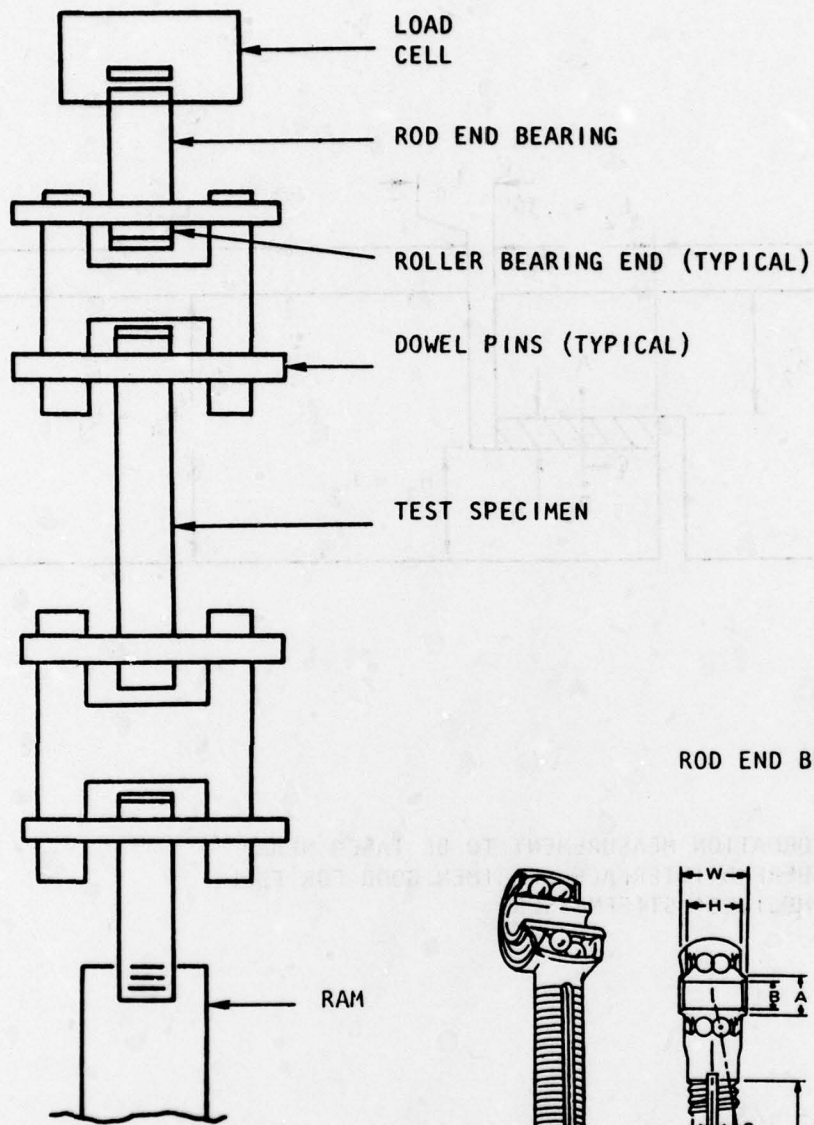

ROD END BEARING

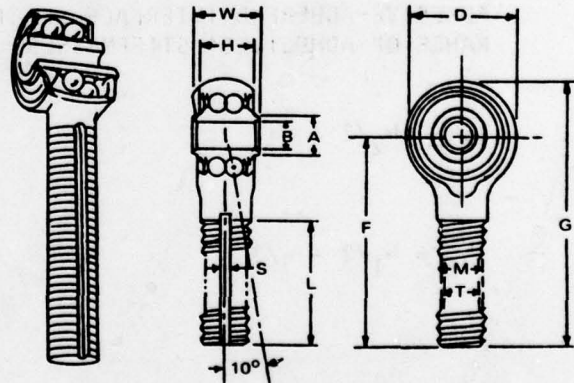
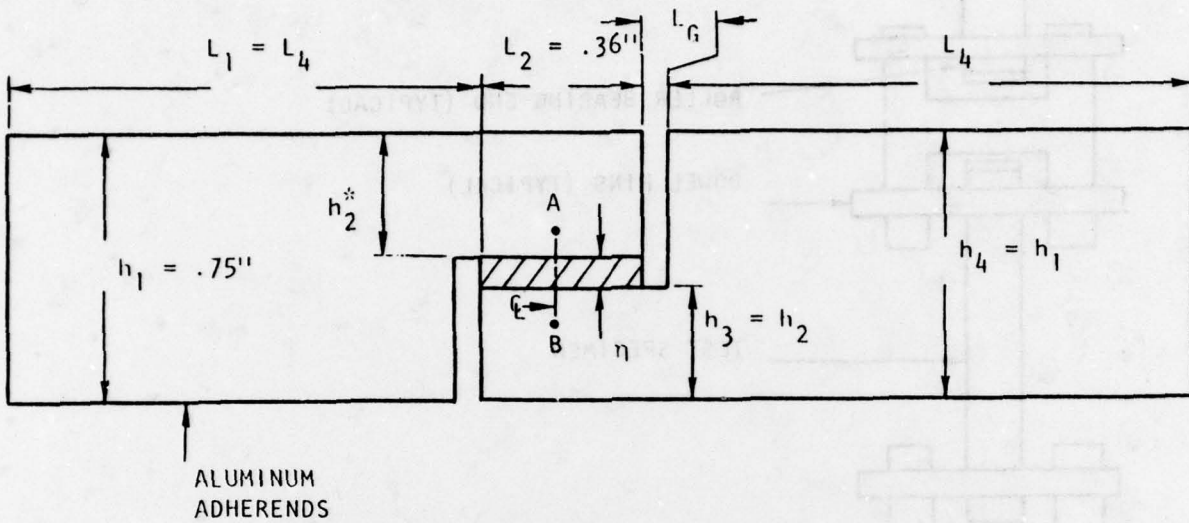

FIGURE 1. TYPICAL TENSILE TEST SETUP USING ROD END BEARINGS



NOTE: ASSUMES DEFORMATION MEASUREMENT TO BE TAKEN NEAR ADHESIVE-ADHEREND INTERFACE-SPECIMEN GOOD FOR FULL RANGE OF ADHESIVES' STIFFNESSES.

$$L_G \cong h_2/2$$

$$h_2^* = h_1/2 - \eta/2$$

FIGURE 2 . SHEAR SPECIMEN OPTIMUM ADHESIVE TEST SPECIMEN GEOMETRY

OPTIMUM DIMENSIONS:

$$R = \frac{h_1}{\eta} \geq 40$$

$$\frac{L_2}{h_1} \geq 4$$

$$\frac{L_1}{L_2} \geq 8$$

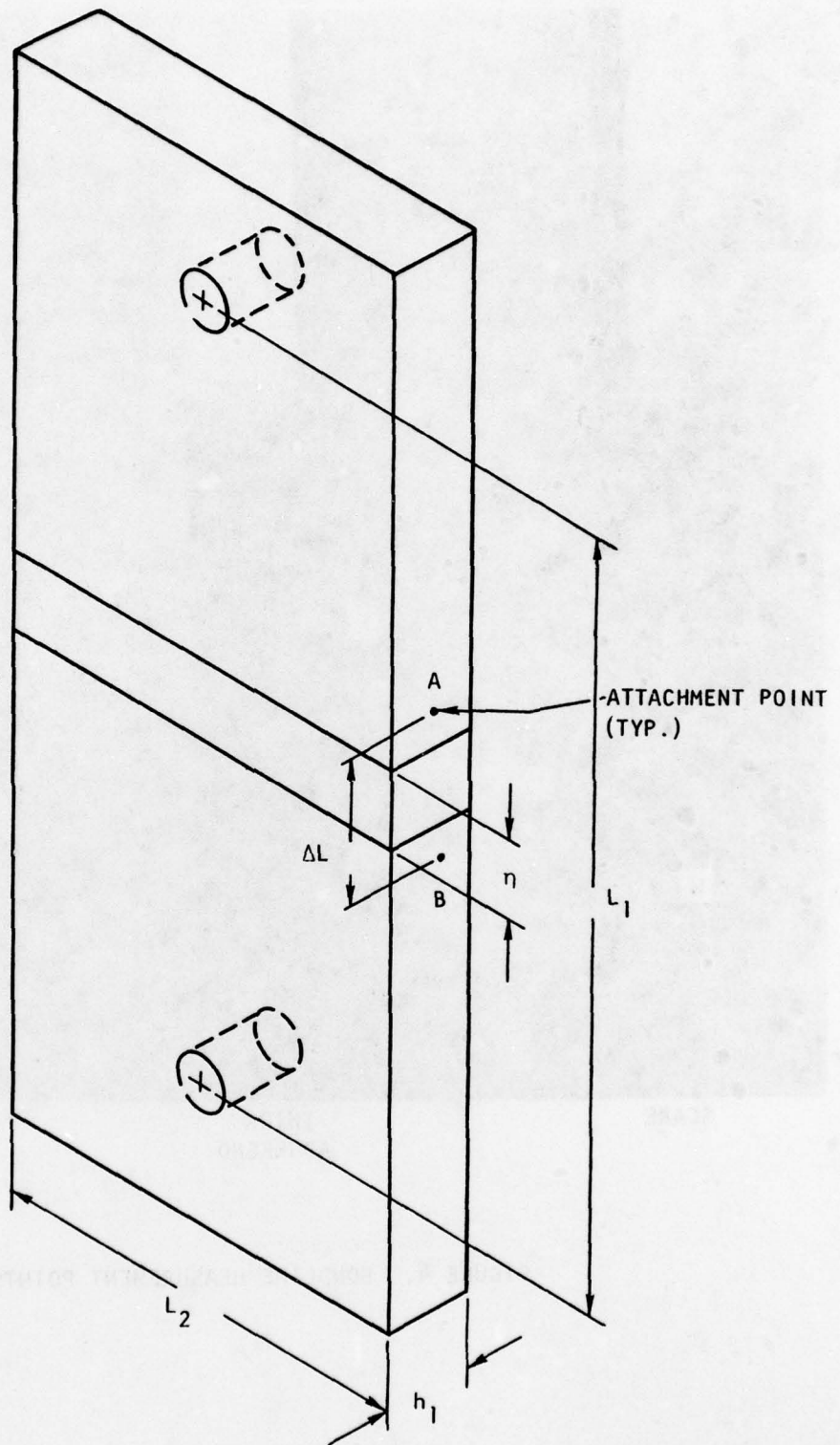

FIGURE 3. TENSILE SPECIMEN OPTIMUM ADHESIVE TEST SPECIMEN GEOMETRY.

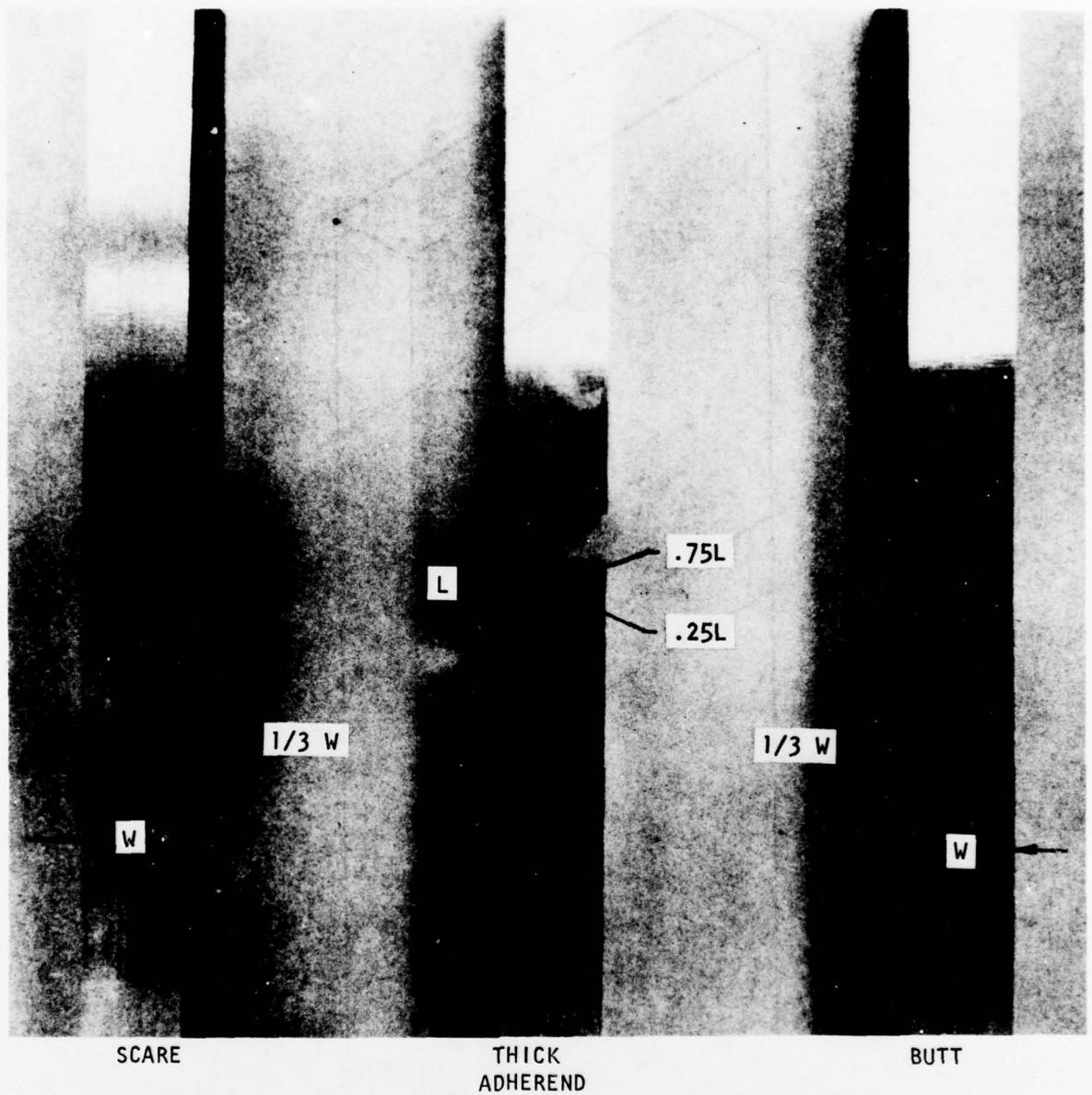

FIGURE 4. BONDLINE MEASUREMENT POINTS.

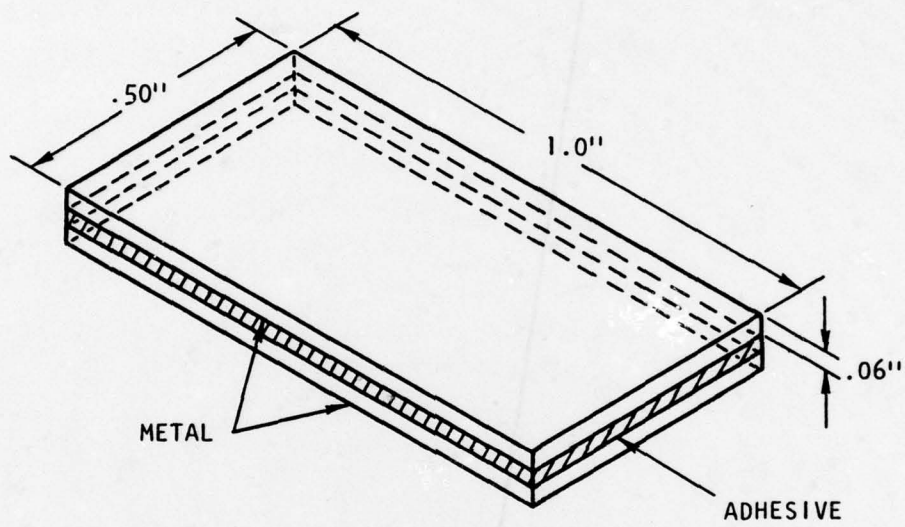

FIGURE 5. MOISTURE CONTROL SPECIMEN

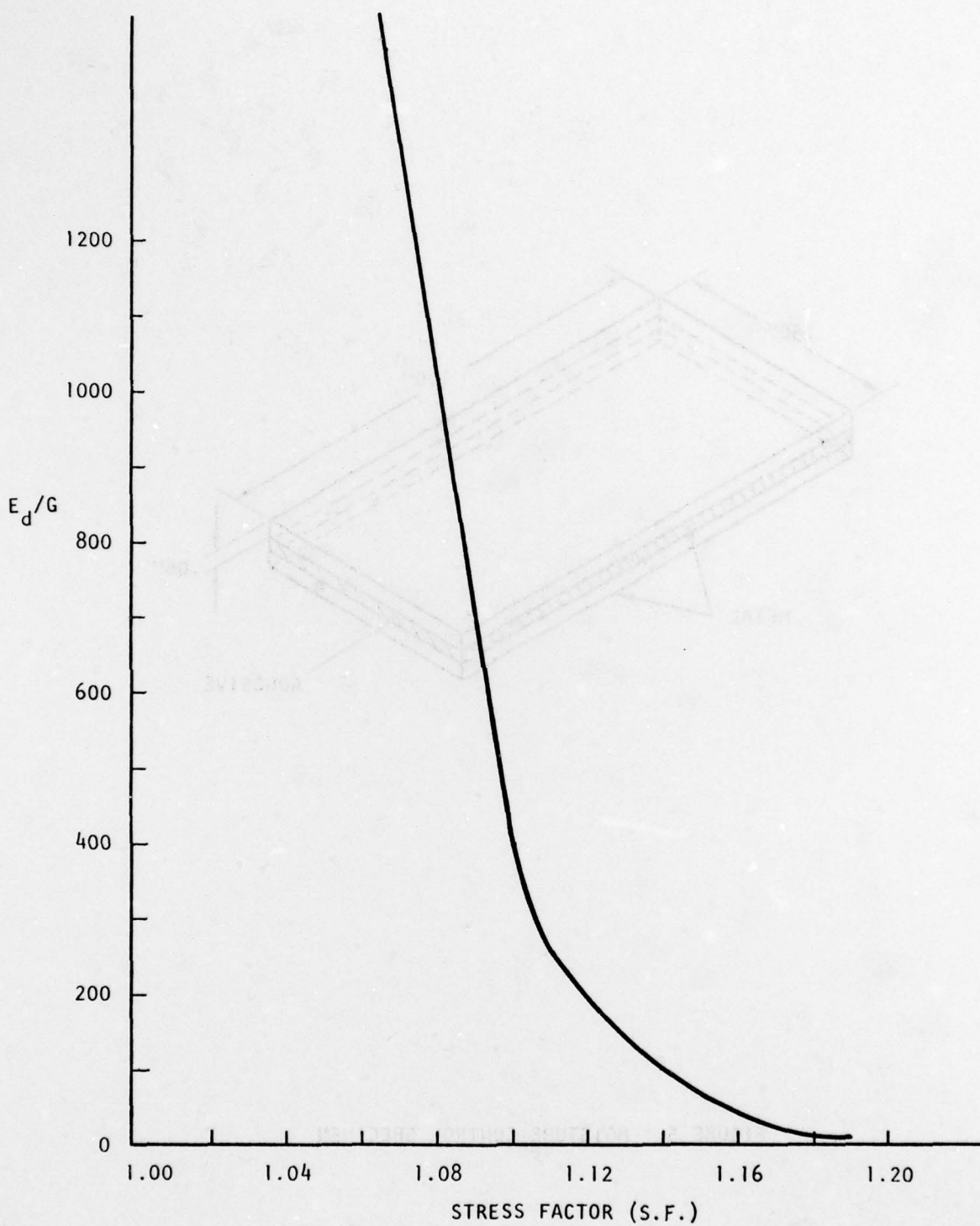

FIGURE 6. STRESS FACTOR VERSUS E_d/G

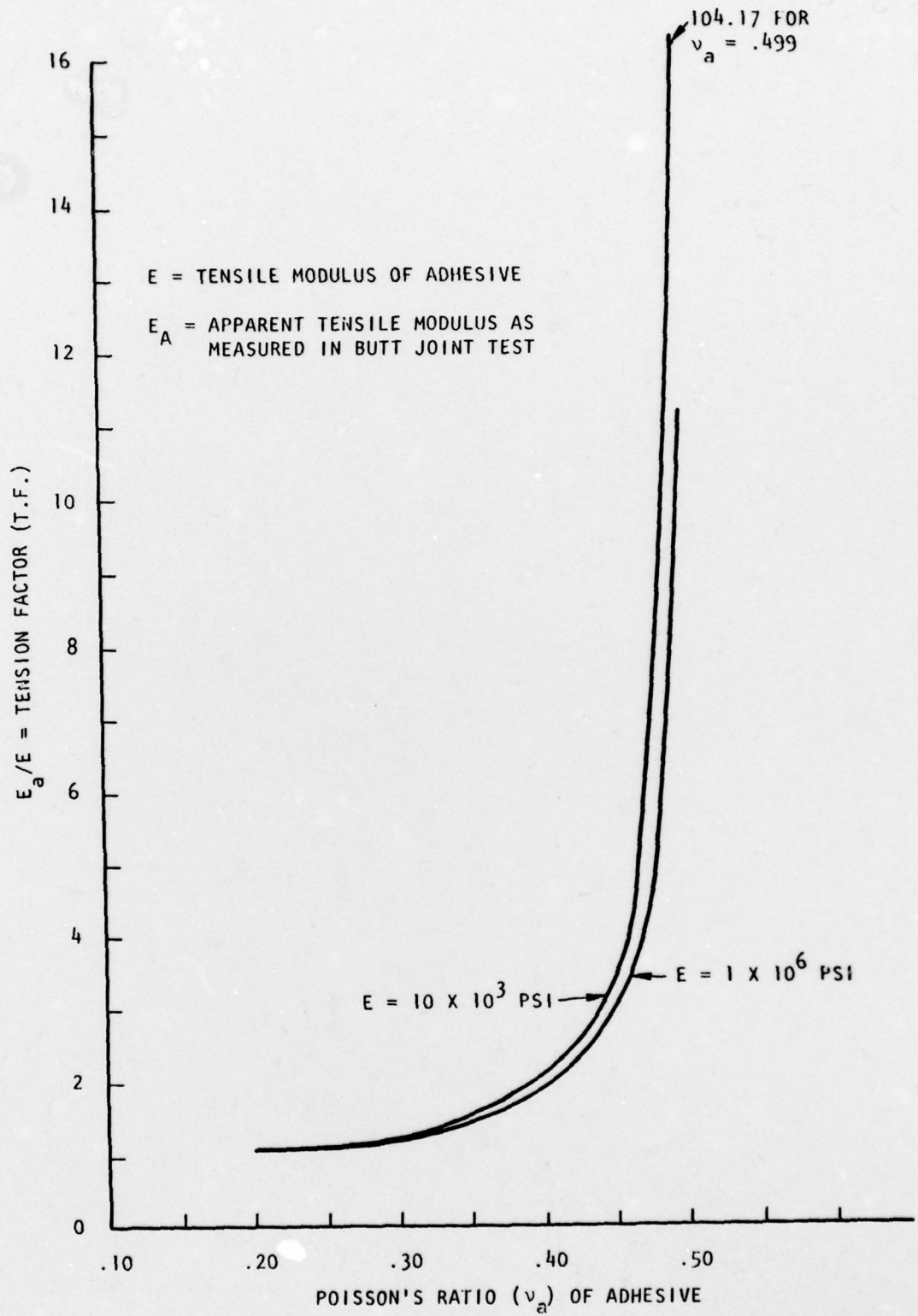

FIGURE 7. TENSILE STRESS FACTOR FOR ALUMINUM ADHERENDS ($40 \leq \text{ASPECT RATIO} \leq 80$).