

AD-A065 446

SACLANT ASW RESEARCH CENTRE LA SPEZIA (ITALY)
SACLANTCEN'S SHIPBOARD WINCHES AND LAUNCH-AND-RECOVERY DEVICES. (U)
MAR 76 V MANZOTTI

F/G 13/3

UNCLASSIFIED

SACLANTCEN-SR-M-86

NL

| OF |
AD
A065446

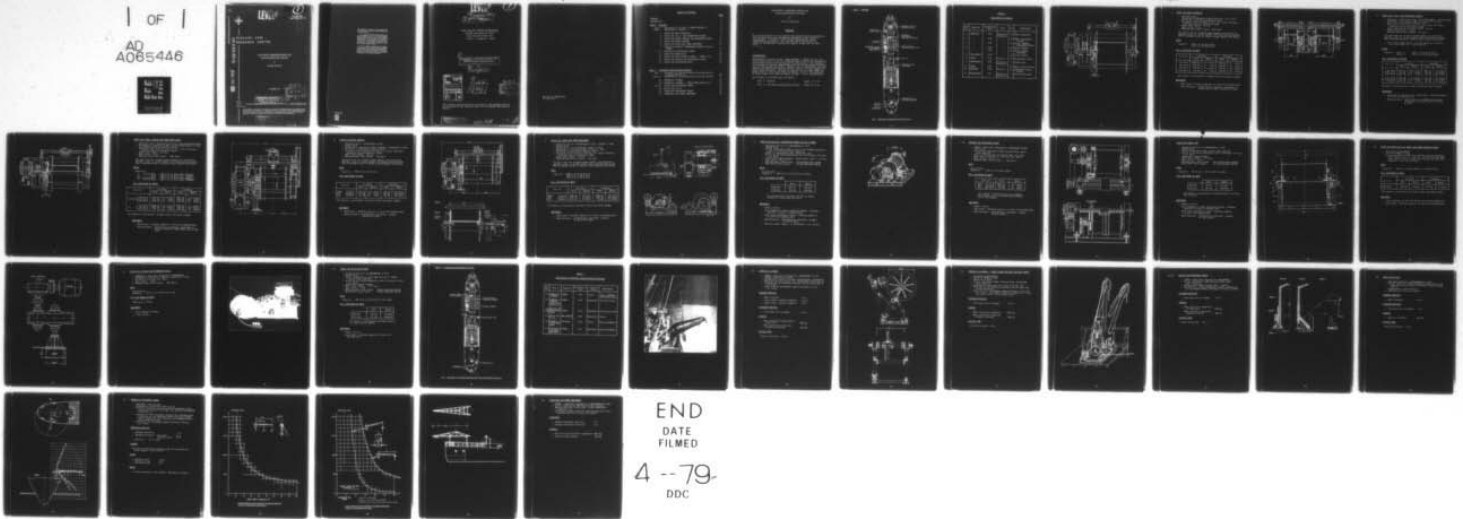

END
DATE
FILMED
4 -- 79
DDC

SACLANTCEN Special Report M-86



LEVEL II

B.S. **1**

SACLANTCEN
Special Report M-86

AD A0 65446

SACLANT ASW
RESEARCH CENTRE

SACLANTCEN'S SHIPBOARD WINCHES AND
LAUNCH-AND-RECOVERY DEVICES

by

VITTORIO MANZOTTI

DDC FILE COPY

15 MARCH 1976

DDC
RECEIVED
MAR 8 1976
REGULATED
D

DISTRIBUTION STATEMENT A

Approved for public release;
Distribution Unlimited

NORTH
ATLANTIC
TREATY
ORGANIZATION

VIALE SAN BARTOLOMEO 400
I-19026 - LA SPEZIA, ITALY

This document is unclassified. The information it contains is published subject to the conditions of the legend printed on the inside cover. Short quotations from it may be made in other publications if credit is given to the author(s). Except for working copies for research purposes or for use in official NATO publications, reproduction requires the authorization of the Director of SACLANTCEN.

DISTRIBUTION STATEMENT A

Approved for public release;
Distribution Unlimited

89 03 01 134

This document is released to a NATO Government at the direction of the SACLANTCEN subject to the following conditions:

1. The recipient NATO Government agrees to use its best endeavours to ensure that the information herein disclosed, whether or not it bears a security classification, is not dealt with in any manner (a) contrary to the intent of the provisions of the Charter of the Centre, or (b) prejudicial to the rights of the owner thereof to obtain patent, copyright, or other like statutory protection therefor.

2. If the technical information was originally released to the Centre by a NATO Government subject to restrictions clearly marked on this document the recipient NATO Government agrees to use its best endeavours to abide by the terms of the restrictions so imposed by the releasing Government.

Published by



LEVEL II

(14) SACLANTCEN-SR-
(9) SPECIAL REPORT M-86 ✓

NORTH ATLANTIC TREATY ORGANIZATION
SACLANT ASW Research Centre
Viale San Bartolomeo 400
I 19026 - La Spezia, Italy

(6) SACLANTCEN'S SHIPBOARD WINCHES AND
LAUNCH-AND-RECOVERY DEVICES.

by
(10) Vittorio Manzotti

ADDITIONAL TO	
DTIC	White Section <input checked="" type="checkbox"/>
DDC	Dist Section <input type="checkbox"/>
UNANNOUNCED	<input type="checkbox"/>
JUSTIFICATION	
BY.....	
DISTRIBUTION/AVAILABILITY CODES	
Dist.	AVAIL. code/w SPECIAL
A	

(11)
15 March 1976

(12) 45p.

DDC
RECEIVED
MAR 8 1979
RECEIVED
D

The opinions expressed herein are those of the authors and are not necessarily the official views of the SACLANT ASW Research Centre.

DISTRIBUTION STATEMENT A
Approved for public release;
Distribution Unlimited

312 950 134 JB

TABLE OF CONTENTS

	<u>Page</u>
ABSTRACT	1
INTRODUCTION	1
<u>PART 1 WINCHES</u>	2
Fig. 1 Positions of winches on MARIA PAOLINA G.	2
Table 1 SACLANTCEN's winches.	3
1. WINCH FOR DEEP ANCHORING	5
2. WINCH FOR T.D.S. AND TRANSDUCER SYSTEM	7
3. WINCH FOR CORER, MEDUSA AND HYDROPHONE ARRAY	9
4. WINCH FOR WATER SAMPLER	11
5. WINCH FOR CORER AND TOWED EQUIPMENT	13
6. WINCH FOR SALINITY TEMPERATURE DEPTH (S.T.D.) PROBE	15
7.-8. WINCHES FOR HORIZONTAL ARRAY	17
9. WINCH FOR TOWED FISH	19
10. WINCH FOR DEEP VERTICAL ARRAY — SHORT V.A.	21
11. WINCH FOR LIFTING THE TRANSDUCER PLATE	23
12. WINCH FOR OSCILLATING BODY	25
<u>PART 2 LAUNCHING-AND-RECOVERY DEVICES</u>	
Fig. 2 Positions of launching-and-recovering devices on MARIA PAOLINA G.	26
Table 2 SACLANTCEN's launching-and-recovering devices	27
20. HYDRAULIC A-FRAME	29
21. HYDRAULIC A-FRAME — CABLE GUIDE FOR D.V.A.	31
22.-23. DAVITS FOR HORIZONTAL ARRAY	33
24. DAVIT FOR S.T.D.	35
25. HYDRAULIC TELESCOPIC CRANE	37
26. OUTRIGGER FOR TOWED EQUIPMENT	41

SACLANTCEN'S SHIPBOARD WINCHES AND
LAUNCH-AND-RECOVERY DEVICES

by

Vittorio Manzotti

ABSTRACT

The characteristics of all winches and launch-and-recovery devices, some of which have been designed or modified to meet specific requirements, available at the SACLANT ASW Research Centre (SACLANTCEN) are listed. The work described represents the effort of SACLANTCEN's Engineering Support Group over the past years.

INTRODUCTION

SACLANTCEN's research vessel, MARIA PAOLINA G. (MPG) and its work boat (T-boat) are, or can be, equipped with a variety of winches and launch-and-recovery devices for use in experiments. This document is provided to acquaint SACLANTCEN staff and collaborating personnel with the facilities available. Tables 1 and 2 respectively list the winches and launch-and-recovery devices and give a brief summary of their characteristics. Details of each one are provided under the number given in the first column of Tables 1 and 2. The positions of these items on the MPG are shown in Figs. 1 and 2 respectively.

The document is divided into two parts:

- | | |
|--|----------------|
| Part 1: Winches | pages 2 to 25 |
| Part 2: Launching-and-Recovery Devices | pages 26 to 41 |

PART 1 - WINCHES

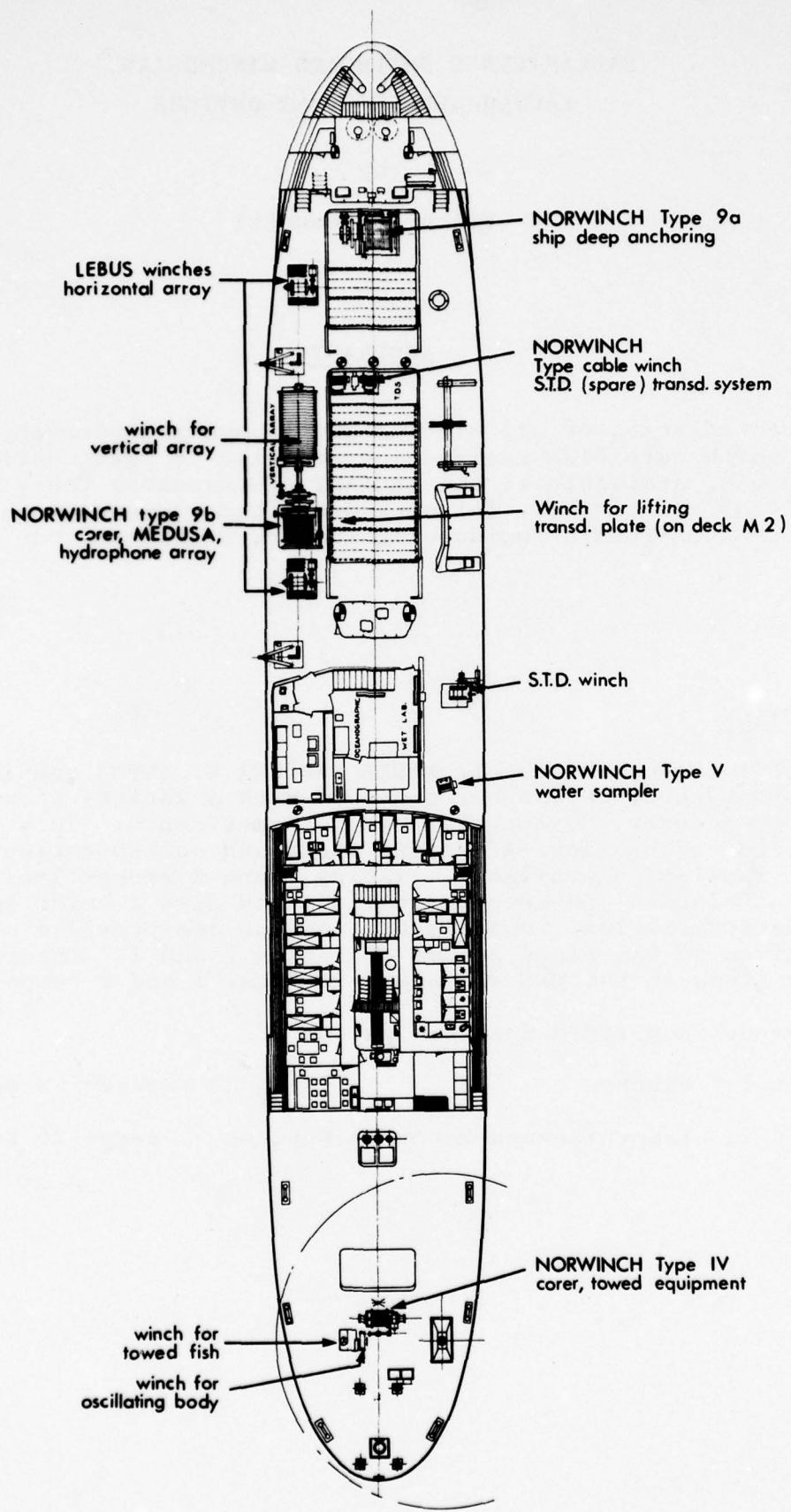
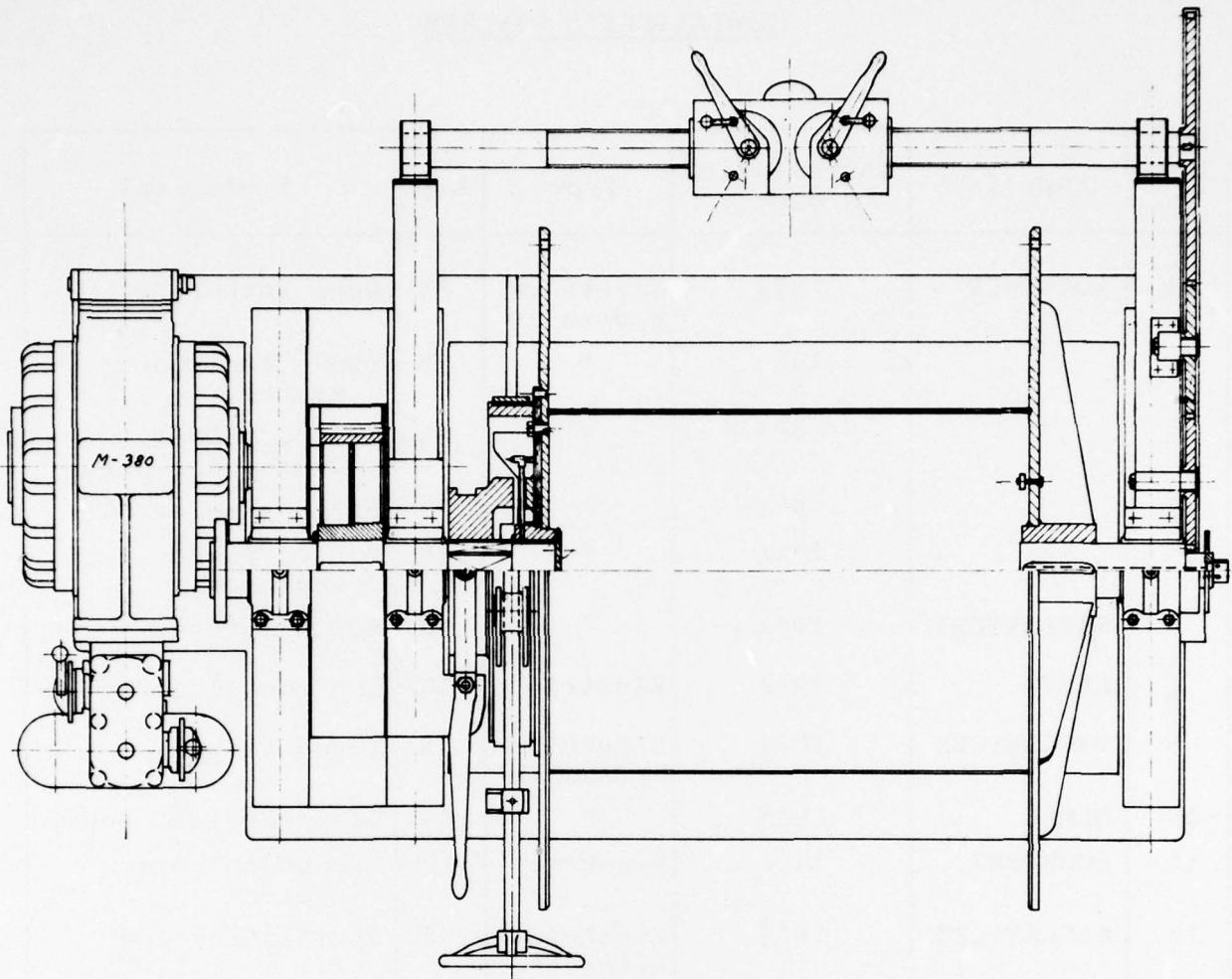

FIG. 1 POSITIONS OF WINCHES ON MARIA PAOLINA G.

TABLE 1SACLANTCEN'S WINCHES

Item No.	Supplier	Installation date	Type	h.p.	Employment
1	NORWINCH	1974	Electric-hydraulic	85	Deep anchoring
2	"	1964	"	38	TDS - Transducer system
3	"	1968	"	85	Corer, MEDUSA, Hydrophone array
4	"	1964	"	25	Water sampler
5	"	1964	"	48	Corer, Towed equipment
6	SACLANTCEN	1974	"	12	S.T.D. probe
7	LEBUS	1974	Electric	10	Horizontal array
8					
9	SACLANTCEN	1974	Electric-hydraulic	5	Towed fish
10	OLMEC	1968	"	85	Deep vertical array
11	SGORBINI	1964	Electric	12	Transducer plate system
12	SACLANTCEN	1975	Electric-hydraulic	2	Oscillating body



1. WINCH FOR DEEP ANCHORING

- . Norwinch type 9
- . Permanently installed on MPG (hatch No. 1) in 1974
- . Driven by a type M-540 hydraulic motor
- . The power unit utilizes a 85 h.p. a.c. motor driving a Norwinch type P 37 hydraulic pump
- . Shaft motor power: 60 h.p.
- . Gear ratio: 1:2.2
- . Maximum shaft drum torque: 2900 kg.m

The motor has two variable speed ranges, one giving the maximum torque at normal speeds (1st step) and one giving 40% of maximum torque at double normal speeds (2nd step).

DRUM

Capacity: 7000 m of 12 mm \emptyset wire
3100 m of 19 mm \emptyset wire

PULL AND SPEED AT DRUM

D R U M	1st Step		2nd Step	
	Pull	Speed	Pull	Speed
312 mm \emptyset	20400 kg	12.5 m/min	8050 kg	25 m/min
500 mm \emptyset	12600 kg	20 m/min	5000 kg	40 m/min
708 mm \emptyset	9000 kg	28.3 m/min	3540 kg	56.6 m/min
1104 mm \emptyset	5750 kg	44 m/min	2270 kg	88 m/min

The speed is continuously variable within the above ranges.

EQUIPMENT

- . Band brake - Holding capacity is twice the maximum pull
- . Spooling gear: Automatically operated, adjustable to accept both 12 and 19 mm \emptyset wire rope.

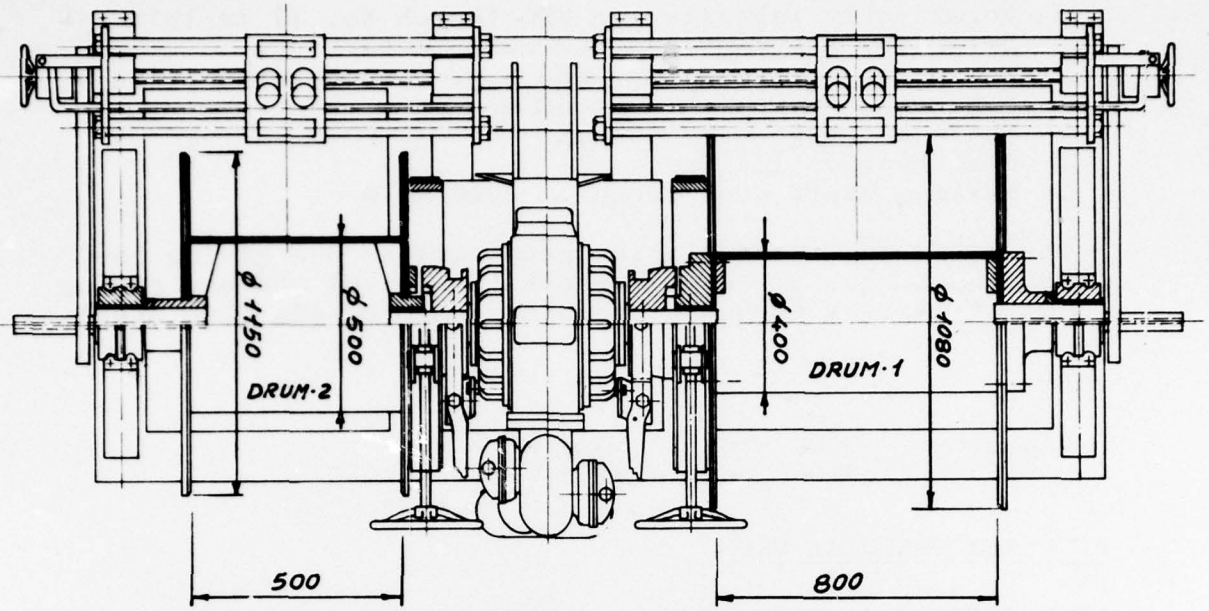

2. WINCH FOR T.D.S. AND TRANSDUCER SYSTEM

- Norwinch - cable-winch type - interchangeable - double drums
- Permanently installed on MPG (hatch No. 2) in 1964
- Driven by a type M-140 hydraulic motor
- The power unit utilize a 85 h.p. a.c. motor driving a Norwinch type P 37 hydraulic pump
- Power required by the motor winch: 38 h.p.
- Shaft motor power: 28 h.p.
- Maximum shaft motor torque: 560 kg.m

The motor has two variable speed ranges, one giving the maximum torque at normal speeds (1st step) and one giving 40% of maximum torque at double normal speeds (2nd step).

- Motor with single shaft; the two drums are joined to the motor shaft by a claw coupling

DRUMS

Capacity: Drum I 5000 m of 10 mm \emptyset cable
 Drum II 6000 m of 6.35 mm \emptyset cable

PULL AND SPEED AT DRUMS

D R U M	1st Step		2nd Step		
	Pull	Speed	Pull	Speed	
I {	410 mm \emptyset	2730 kg	46.5 m/min	1092 kg	93 m/min
	730 mm \emptyset	1515 kg	81.5 m/min	600 kg	103 m/min
	1050 mm \emptyset	1040 kg	122 m/min	415 kg	244 m/min
II {	510 mm \emptyset	2200 kg	57.5 m/min	880 kg	115 m/min
	730 mm \emptyset	1515 kg	83.5 m/min	600 kg	167 m/min
	950 mm \emptyset	1145 kg	111 m/min	450 kg	222 m/min

Speeds are continuously variable within the above ranges.

EQUIPMENT

- Each drum is equipped with a band brake - Holding capacity is twice the maximum pull
- Spooling gear: Each drum has an ALMEK spooling gear adjustable to accept from 4 to 30 mm \emptyset cable.

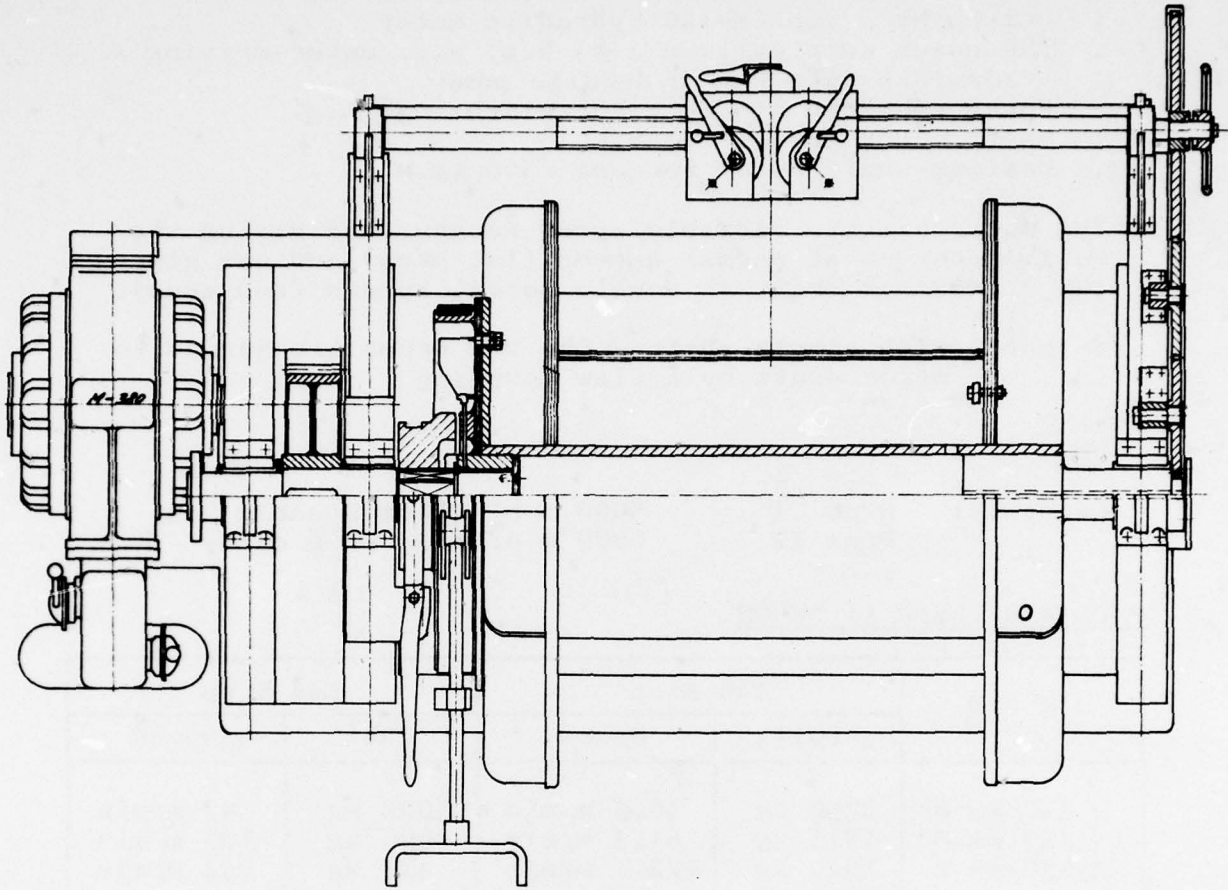

3. WINCH FOR CORER, MEDUSA AND HYDROPHONE ARRAY

- . Norwinch type 9 (modified) with four interchangeable drums
- . Permanently installed on MPG (forward deck port) in 1968
- . Driven by a type M-540 hydraulic motor
- . The power unit utilizes a 85 h.p. a.c. motor driving a Norwinch type P 37 hydraulic motor
- . Shaft motor power: 60 h.p.
- . Gear ratio: 1:2.2
- . Maximum shaft drum torque: 2900 kg.m

The motor has two variable speed ranges, one giving the maximum torque at normal speeds (1st step) and one giving 40% of maximum torque at double normal speeds (2nd step).

DRUMS

Capacities

I	Grooved Drum	4500 m of 19 mm \emptyset cable (D.V.A.)
II	Drum	7000 m of 12 mm \emptyset wire (CORER)
III	Grooved Drum	1500 m of 19 mm \emptyset cable (D.S.L.)
IV	Grooved Drum	2500 m of 17 mm \emptyset cable (MEDUSA)

PULL AND SPEED AT DRUMS

D R U M	1st Step		2nd Step		
	Pull	Speed	Pull	Speed	
I-III-IV {	898 mm \emptyset	7050 kg	35.8 m/min	2800 kg	71.6 m/min
	1348 mm \emptyset	4720 kg	54 m/min	1860 kg	108 m/min
	1798 mm \emptyset	3540 kg	72 m/min	1400 kg	144 m/min
II {	312 mm \emptyset	20400 kg	12.5 m/min	8050 kg	25 m/min
	708 mm \emptyset	9000 kg	28.3 m/min	3540 kg	56.6 m/min
	1104 mm \emptyset	5750 kg	44 m/min	2270 kg	88 m/min

The speed is continuously variable within the above ranges.

EQUIPMENT

- . Band brake - Holding capacity is twice the maximum pull
- . Spooling gear: Automatically operated, adjustable to accept 19 mm \emptyset , 17 mm \emptyset cable and 12 mm \emptyset wire.

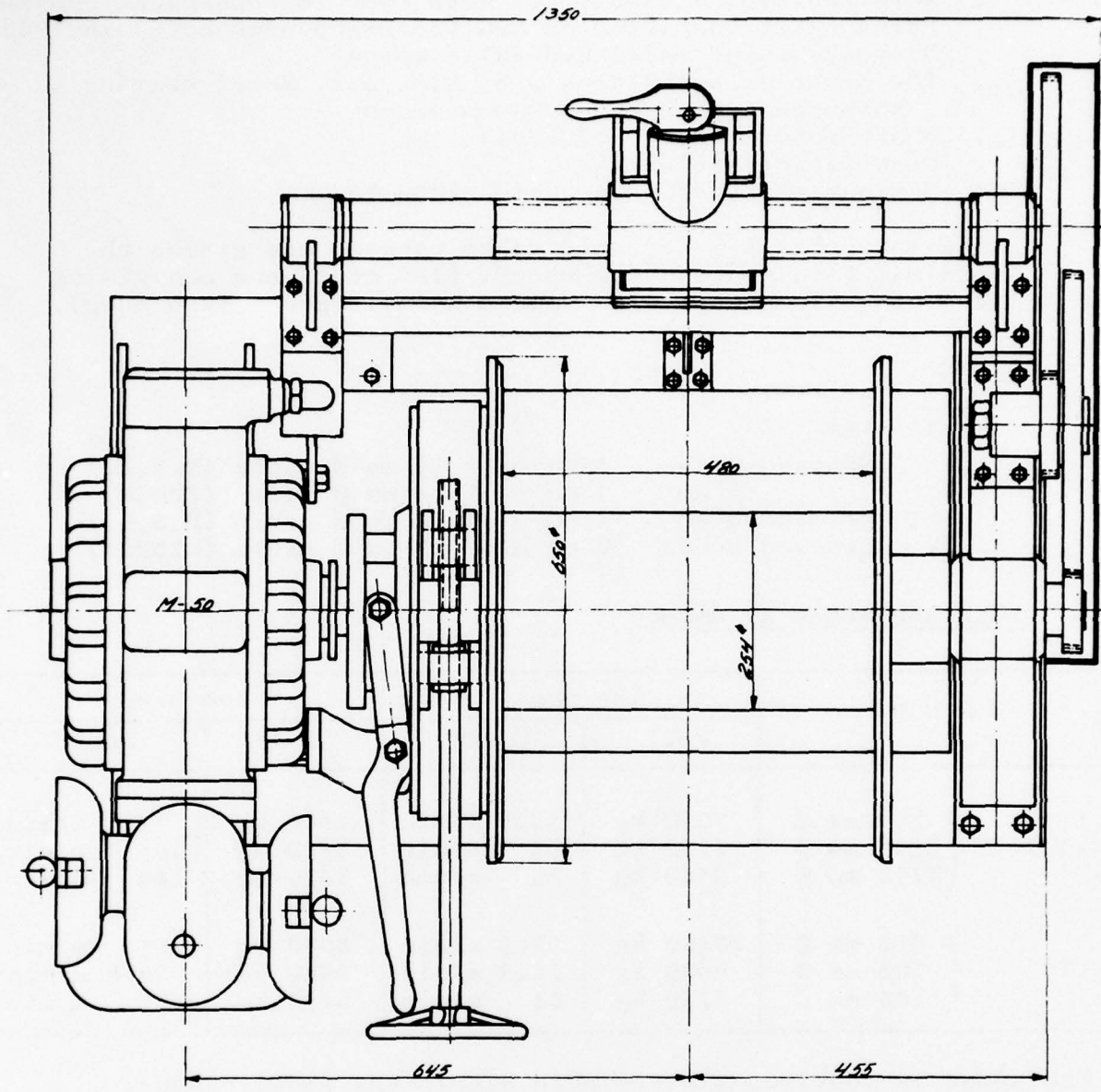

4. WINCH FOR WATER SAMPLER

- . Norwinch type V hydrographic winch
- . Single drum
- . Permanently installed on MPG (midships, starboard) in 1964
- . Driven by a type M-50 hydraulic motor
- . The power unit utilizes a 25 h.p. a.c. motor driving a Norwinch type P 09 hydraulic pump
- . Shaft motor power: 18 h.p.
- . Maximum shaft drum torque: 200 kg.m

The motor has two variable speed ranges, one giving the maximum torque at normal speeds (1st step) and one giving 25% of maximum torque at double normal speeds (2nd step).

DRUM

Capacity: 6000 m of 4 mm \emptyset wire

PULL AND SPEED AT DRUM

D R U M		1st Step		2nd Step	
		Pull	Speed	Pull	Speed
Empty	258 mm \emptyset	1550 kg	52.5 m/min	390 kg	105 m/min
Mid	410 mm \emptyset	975 kg	84 m/min	240 kg	168 m/min
Full	562 mm \emptyset	710 kg	115 m/min	180 kg	230 m/min

The speed is continuously variable within the above ranges.

EQUIPMENT

- . Band brake - Holding capacity is twice the maximum pull
- . Spooling gear: Automatically operated; accepts 4 mm \emptyset wire rope.

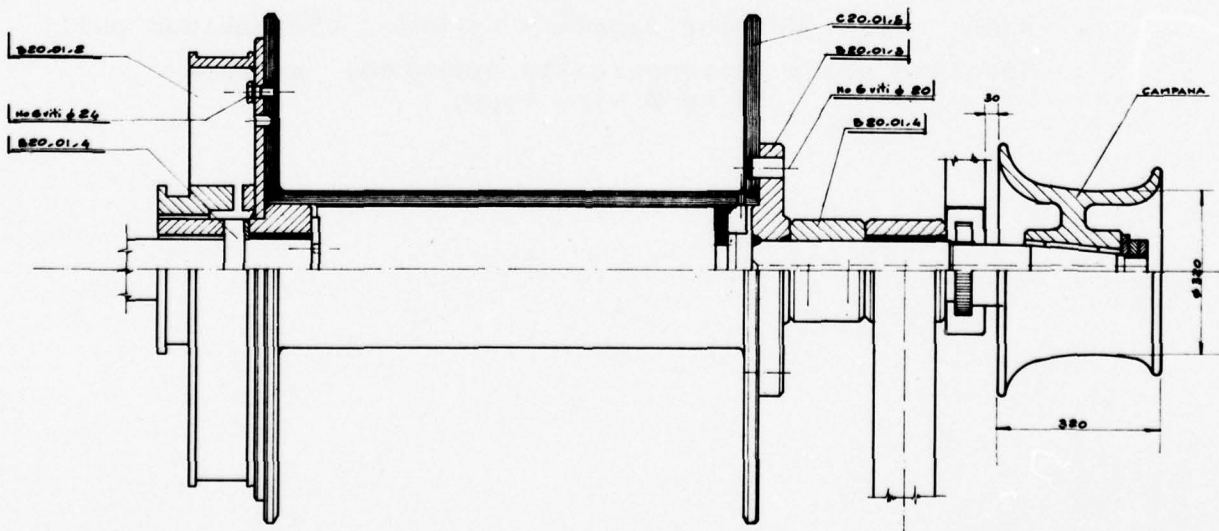
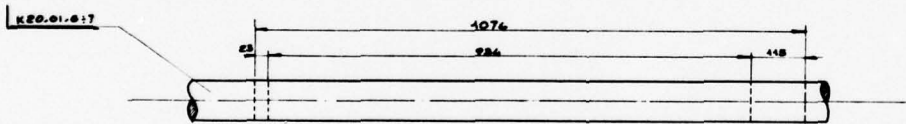
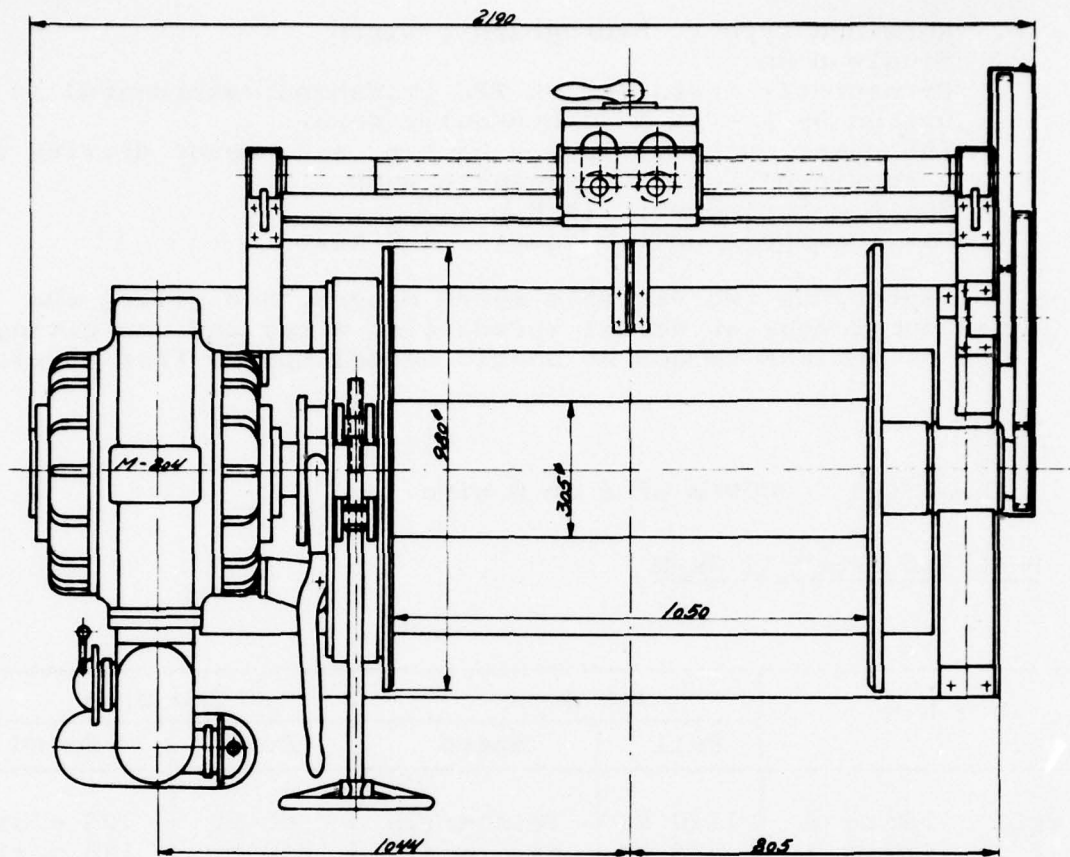

5. WINCH FOR CORER AND TOWED EQUIPMENT

- . Norwinch type IV hydrographic winch - bought in 1964
- . Single drum
- . Modified for interchangeable drums in 1974
- . Permanently installed on MPG (stern) in 1968
- . Driven by a type M-204 hydraulic motor
- . The power unit utilizes a 48 h.p. a.c. motor driving a Norwinch type P17 hydraulic pump
- . Shaft motor power: 34 h.p.
- . Maximum shaft drum torque: 816 kg.m

The motor has two variable speed ranges, one giving the maximum torque at normal speeds (1st step) and one giving 40% of maximum torque at double normal speeds (2nd step).

DRUM

Capacity: 4000 m of 10 mm \emptyset wire
 3000 m of 12 mm \emptyset wire
 1100 m of 19 mm \emptyset wire

PULL AND SPEED AT DRUM

D R U M		1st Step		2nd Step	
		Pull	Speed	Pull	Speed
Empty	315 mm \emptyset	5200 kg	30 m/min	1900 kg	60 m/min
Mid	575 mm \emptyset	2850 kg	54 m/min	1050 kg	108 m/min
Full	830 mm \emptyset	1950 kg	78 m/min	720 kg	156 m/min

The speed is continuously variable within the above ranges.

EQUIPMENT

- . Band brake - Holding capacity is twice the maximum pull
- . Spooling gear: Automatically operated; accepts 12 mm \emptyset wire rope.

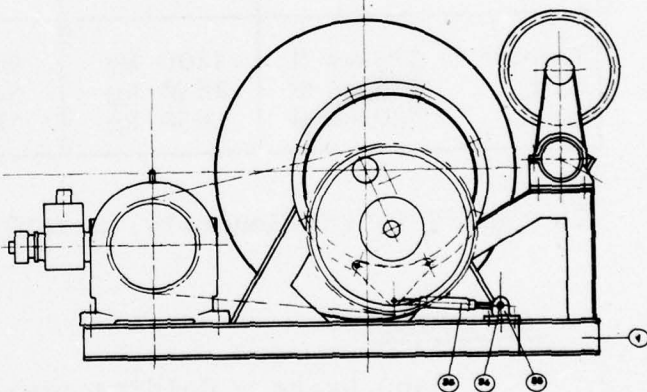
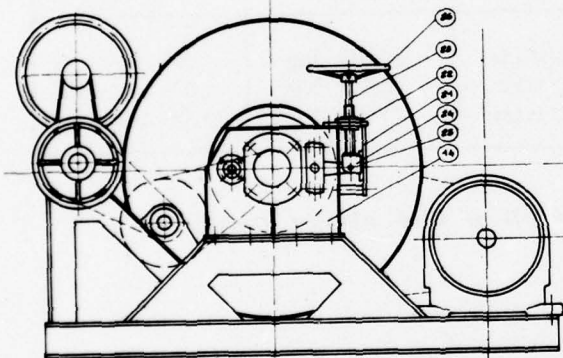
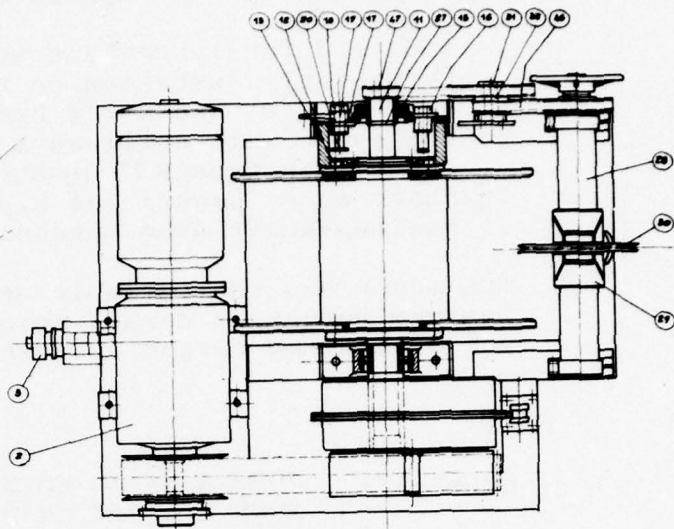
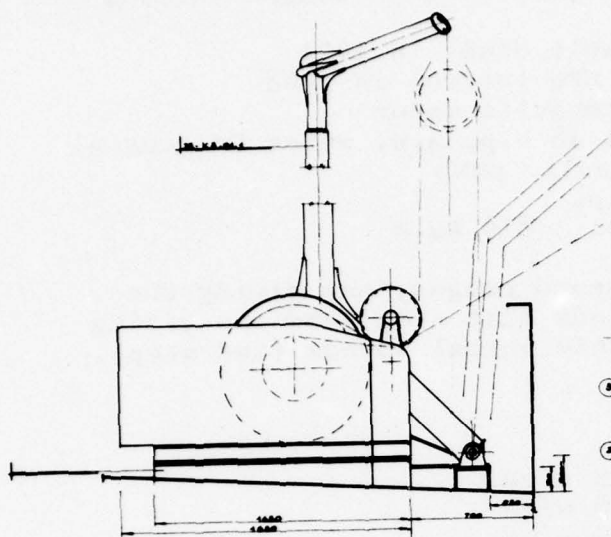

6. WINCH FOR SALINITY TEMPERATURE DEPTH (S.T.D.) PROBE

- . Designed and built by SACLANTCEN in 1974
- . Single drum
- . Can be installed on MPG in one of two midship positions (port or starboard) when required
- . Works in conjunction with a davit (No. 24)
- . Driven by an electro-hydraulic unit utilizing a 12.5 h.p. a.c. motor
- . Hydrostatic speed changer - shaft motor power: 9.5 h.p.
- . Gear ratio: 27.75:1
- . Maximum shaft drum torque: 220 kg.m (minimum speed)
- . Work shaft drum torque: 110 kg.m (maximum speed)

DRUM

Grooved drum
Capacity: 3000 m of 6.32 mm ϕ wire (cable)

PULL AND SPEED AT DRUM

	Pull	Speed
Maximum	1000 kg	minimum
Working	500 kg	maximum

Can automatically maintain ($\pm 5\%$) any speed between 1.2 m/min and 120 m/min.

EQUIPMENT

- . Remote control
- . Electromagnetic brake (operating brake) - Holding capacity is equal to maximum pull
- . Block brake (emergency brake) - Holding capacity is twice the maximum pull
- . Spooling gear: Automatically operated; accepts 6.35 mm ϕ cable
- . Electric power supply - 10 kW 208/117 V a.c. 60 Hz.

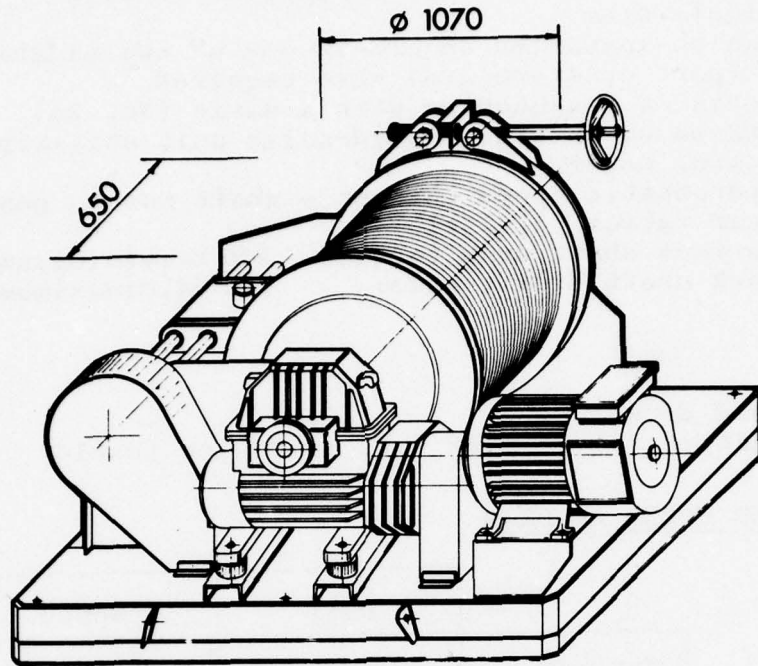

7-8. WINCHES FOR HORIZONTAL ARRAY

- . LEBUS - Especially designed for SACLANTCEN (1974)
- . Fixed drum
- . Two can be installed on MPG (forward deck, port) when required
- . Work in conjunction with davits (Nos. 22 & 23)
- . Each winch is driven by a 10 h.p. d.c. motor
- . Gear ratio: 176.5:1
- . Maximum shaft drum torque: 430 kg.m

DRUM

Grooved drum

Capacity: 1100 m of 18 mm \emptyset cable

PULL AND SPEED AT DRUM

D R U M	Pull	Speed
Empty 518 mm \emptyset	1800 kg	15.3 m/min
Mid 750 mm \emptyset	1145 kg	22 m/min
Full 1000 mm \emptyset	860 kg	30 m/min

Four speeds in both directions at roughly equal steps, with the lowest approximately 1/8 of the highest.

EQUIPMENT

- . Remote control
- . Band brake - Holding capacity is twice the maximum pull
- . Spooling gear: Automatically operated; accepts 18 mm \emptyset cable.

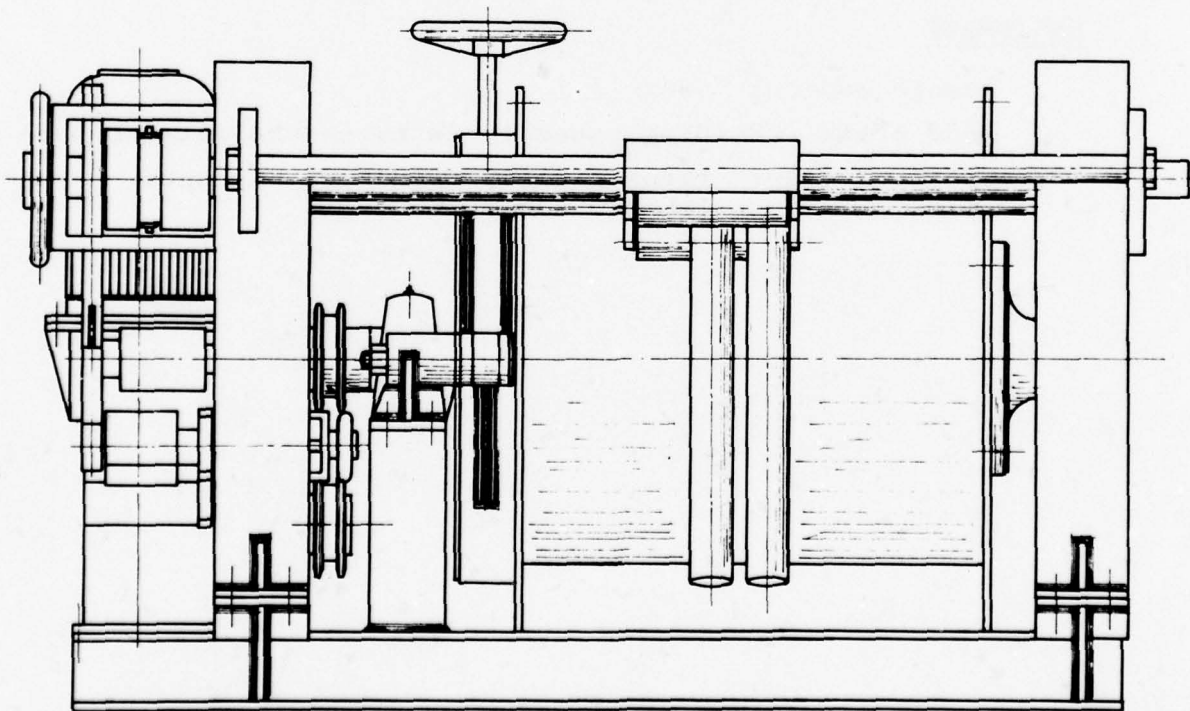
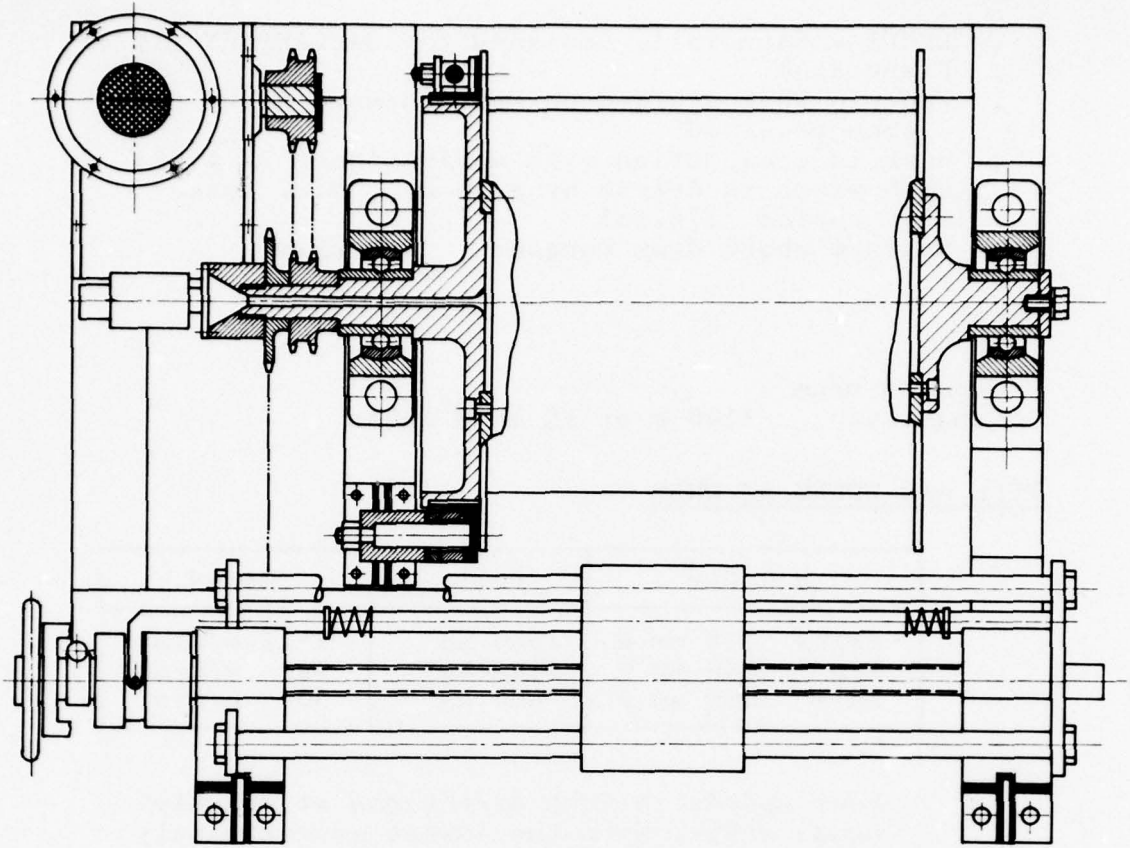

9. WINCH FOR TOWED FISH

- . Designed and built by SACLANTCEN in 1974
- . Single drum
- . Can be installed on MPG (stern) when required
- . Driven by an electro-hydraulic unit utilizing a 5.5 h.p. a.c. motor
- . Hydrostatic speed changer
- . Shaft motor power: 4.5 h.p.
- . Gear ratio: 1:75.6
- . Maximum shaft drum torque: 330 kg.m (minimum speed)
- . Work shaft drum torque: 165 kg.m (maximum speed)

DRUM

Capacity: 500 m of 9.5 mm \emptyset (3/8 in) cable

PULL AND SPEED AT DRUM

	Pull	Speed
Maximum	890 kg	minimum
Working	445 kg	maximum

The speed is continuously variable between 1.2 m/min and 35 m/min.

EQUIPMENT

- . Remote control
- . Electromagnetic brake (operating brake) - Holding capacity is equal to maximum pull
- . Band brake (emergency brake) - Holding capacity is twice the maximum pull
- . Spooling gear: Automatically operated; accepts 9.5 mm \emptyset cable.

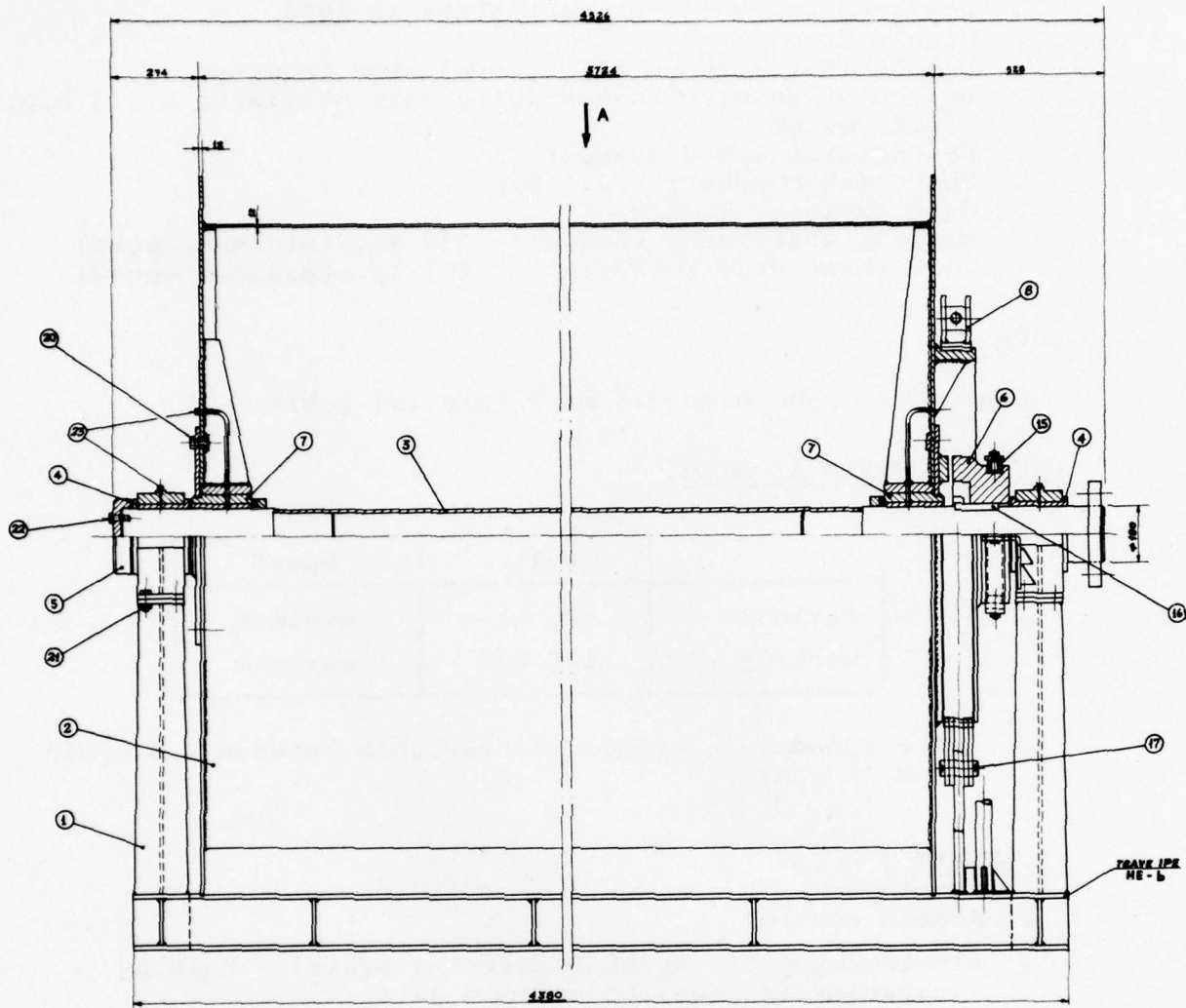

10. WINCH FOR DEEP VERTICAL ARRAY AND SHORT VERTICAL ARRAY

- . Designed by SACLANTCEN
- . Built by OLMEC in 1968
- . Can be installed on MPG (forward deck, port) alongside the Norwinch type 9 winch (No. 3) utilizing the same motor power by a universal joint having the same full capacity of the driven shaft.

DRUM

Capacity: 900 m of 19 mm \emptyset cable on a single layer

PULL AND SPEED AT DRUM

D R U M	1st Step		2nd Step	
	Pull	Speed	Pull	Speed
2000 mm \emptyset	2900 kg	35 m/min	1160 kg	70 m/min

The speed is continuously variable within the above ranges.

EQUIPMENT

- . Claw coupling, so that the drums can be used separately
- . Band brake - Holding capacity is twice the maximum pull.

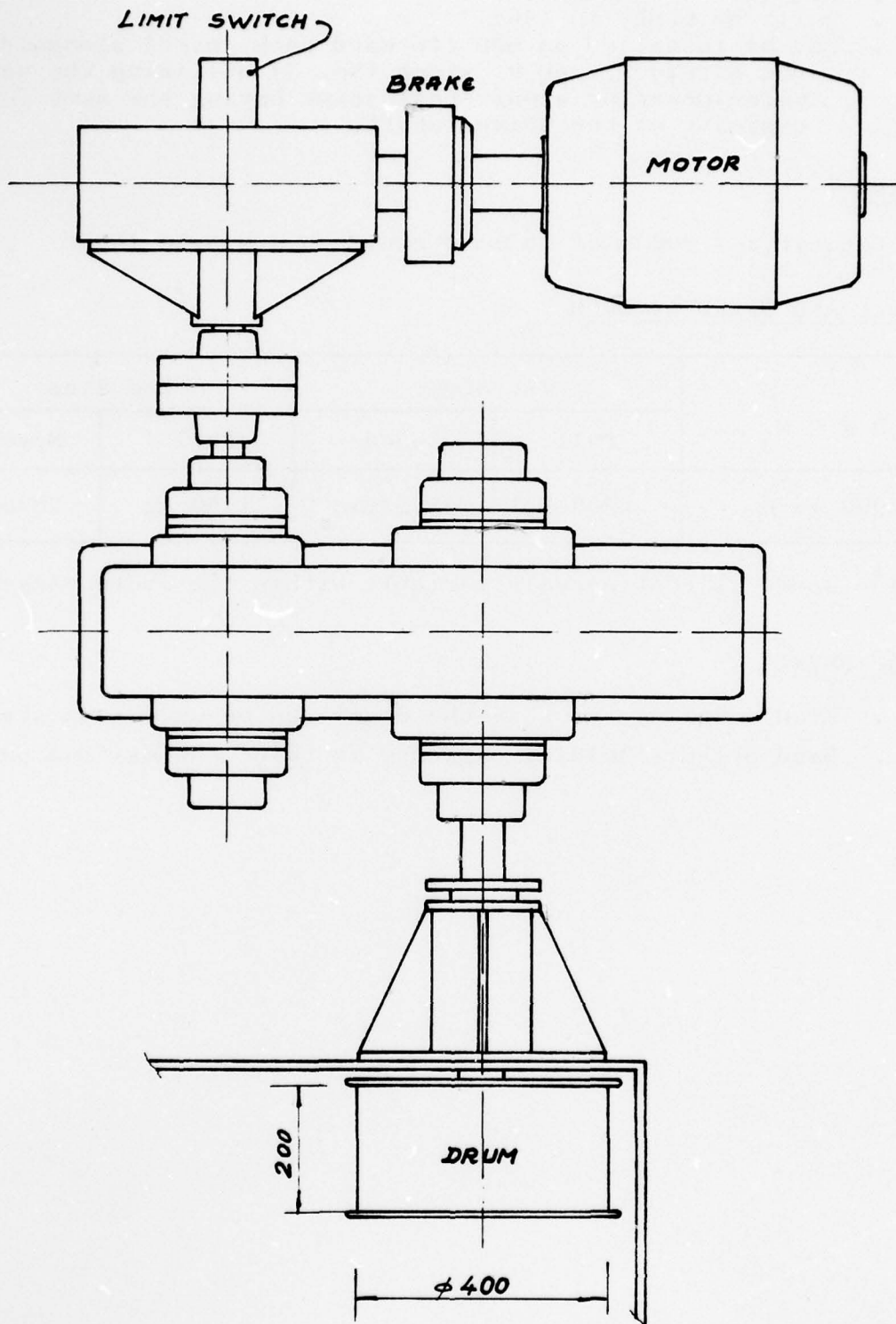

11. WINCH FOR LIFTING THE TRANSDUCER PLATE

- SGORBINI - Especially designed for SACLANTCEN
- Permanently installed on MPG (on deck M.2) in 1964
- Driven by a 10 h.p. a.c. motor
- Gear ratio: 1:275
- Maximum shaft drum torque: 1000 kg.m

DRUM

Grooved drum
Capacity: 12.5 m of 19 mm \emptyset wire rope

PULL AND SPEED AT DRUM

5000 kg at 5 m/min

EQUIPMENT

- Electromagnetic brake
- Limit switch

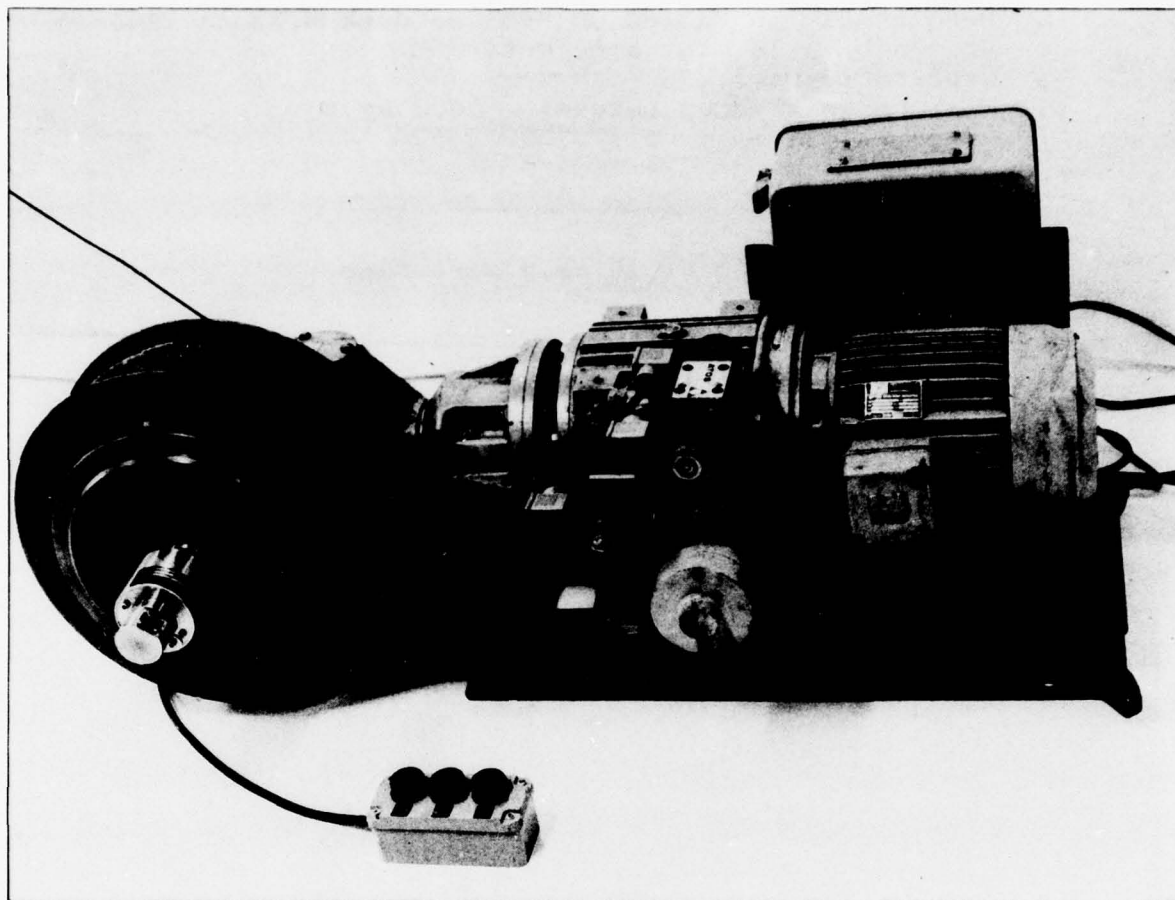

12. WINCH FOR OSCILLATING BODY

- . Designed and built by SACLANTCEN in 1975
- . Single drum
- . Can be installed on either MPG (stern) or T-Boat (stern) when required
- . Driven by an electro-hydraulic unit utilizing a 2 h.p. a.c. motor
- . Hydrostatic speed changer
- . Shaft motor power: 1.75 h.p.
- . Gear ratio: 1:29
- . Maximum shaft drum torque: 50 kg.m (minimum speed)
- . Work shaft drum torque: 25 kg.m (maximum speed)

DRUM

Capacity: 500 m of 3.175 mm \emptyset (1/8 in) cable

PULL AND SPEED AT DRUM

	Pull	Speed
Maximum	250 kg	minimum
Working	125 kg	maximum

The speed is continuously variable between 1.8 m/min and 72 m/min.

EQUIPMENT

- . Remote control
- . Band brake - Holding capacity is twice the maximum pull.

PART 2 - LAUNCHING-AND-RECOVERY DEVICES

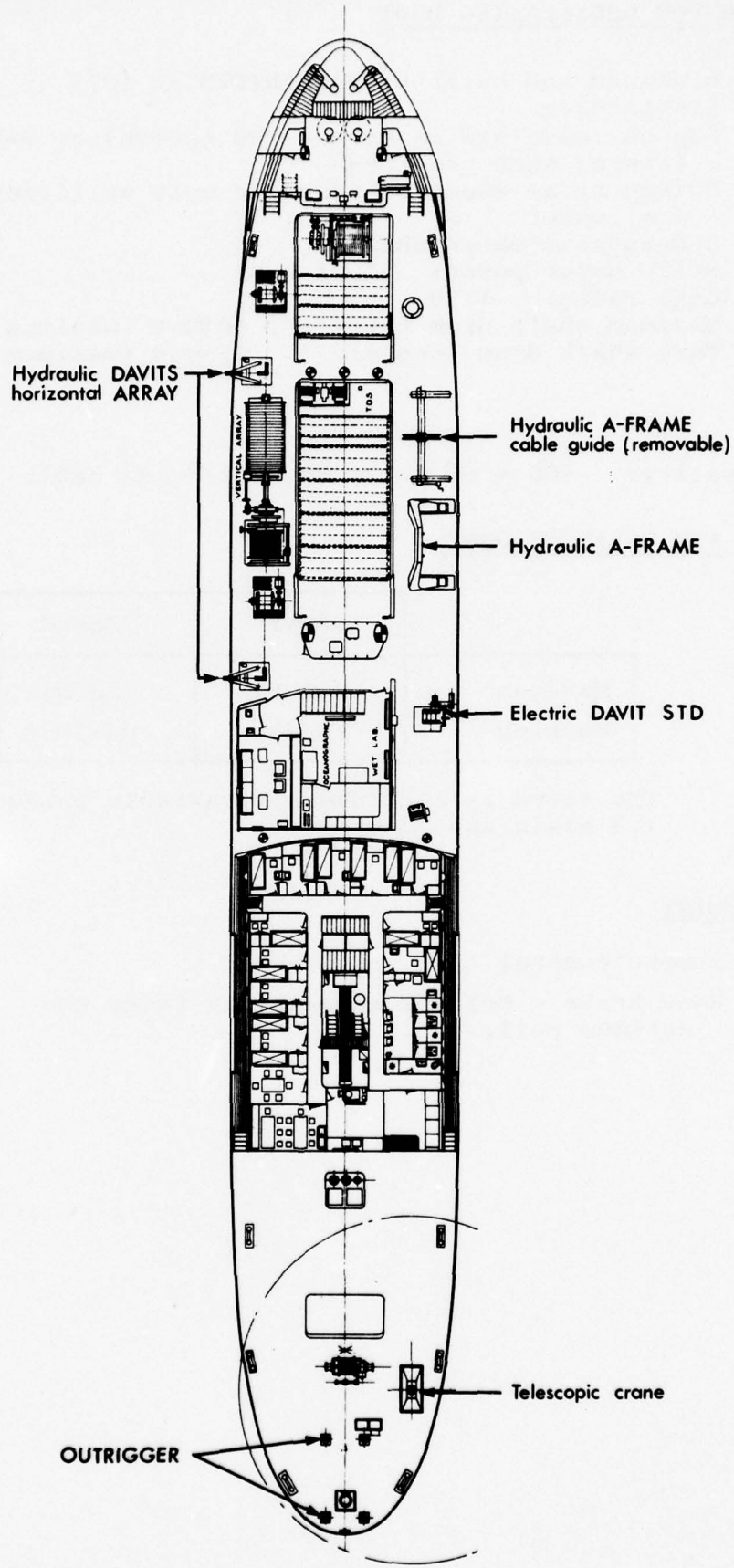
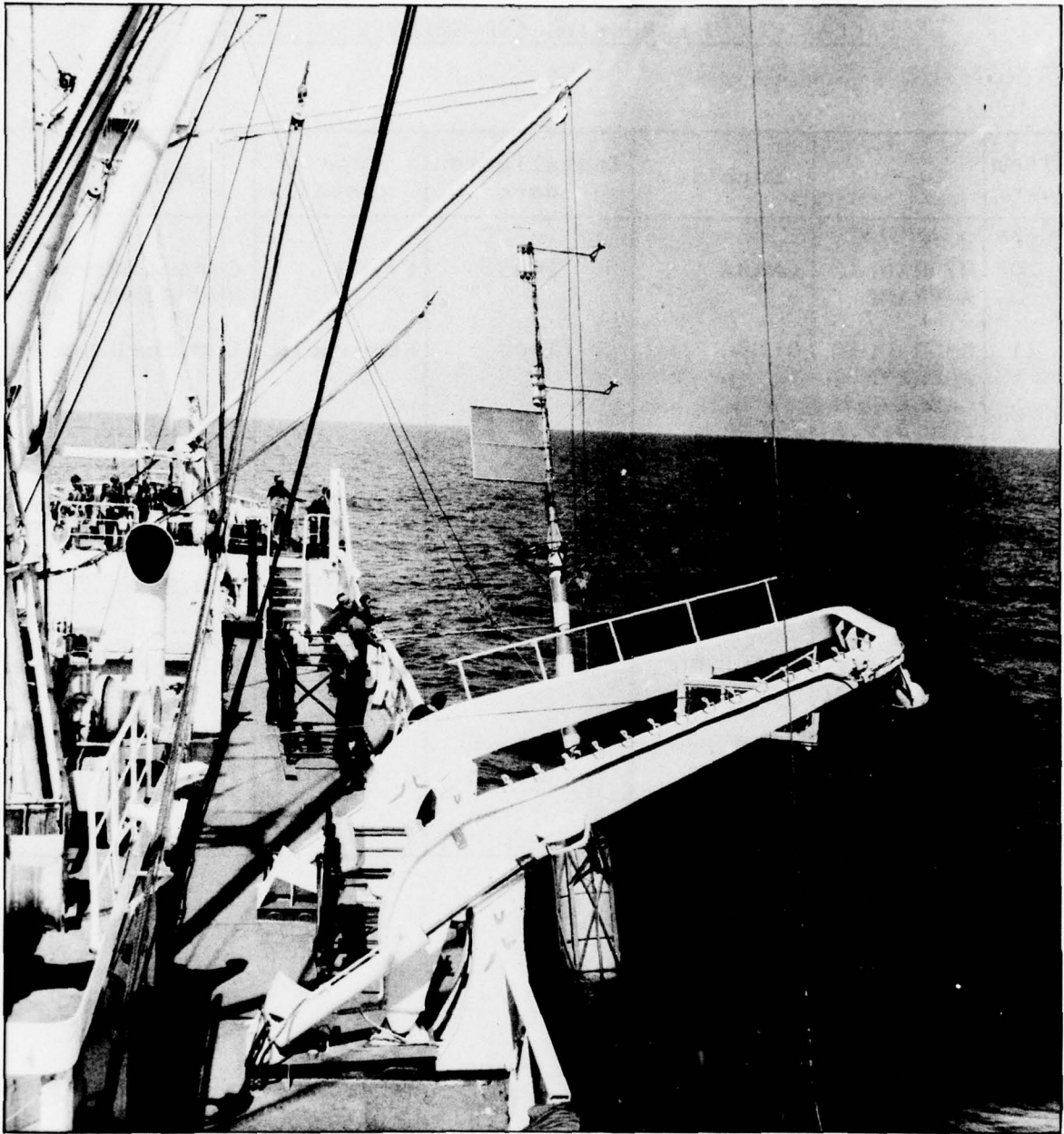

FIG. 2 POSITIONS OF LAUNCHING-AND-RECOVERY DEVICES ON MARIA PAOLINA G.

TABLE 2

SACLANTCEN'S LAUNCHING-AND-RECOVERING DEVICES

Item No.	Device	Supplier	Installation date	Type of install.	Employment
20	HYDRAULIC A-FRAME	CNASA	1965	Fixed	Corer, MEDUSA, Hydrophone array
21	HYDRAULIC A-FRAME CABLE GUIDE FOR D.V.A.	OLMEC	1968	Removable	Vertical array
22 } 23 }	DAVITS FOR HORIZONTAL ARRAY	LEBUS	1974	Removable	Horizontal array
24	DAVIT FOR S.T.D.	SACLANTCEN	1974	Removable	T.D.S.
25	HYDRAULIC TELESCOPIC CRANE	PAGLIERO	1974	Fixed	Buoy, Transducer
26	OUTRIGGER FOR TOWED EQUIPMENT	TECMEL	1970	Removable	Towed equipment



20. HYDRAULIC A-FRAME

- . CNASA - Especially designed for SACLANTCEN in 1965
- . TECNEL - Modified in 1970
- . Permanently installed on MPG (forward deck, starboard)
- . Working with corer winch (No. 3) and cable winch (No. 2)
- . Actuated by two hydraulic pistons, one on each side of the frame
- . Powered by an oil-dynamic pump utilizing a 8 h.p. a.c. motor

INBOARD POSITION

- . Deck clearance 6.5 m
- . Lower width - between supports 3.35 m
- . Upper width - between supports 1.6 m

OUTBOARD POSITION

- . From ship rail to hanger 4.6 m

LOADING

- . When statically supported at ship rail 8000 kg
- . When luffing by using the hydraulic pistons 3150 kg

LUFFING TIME

Either direction: 1 min.

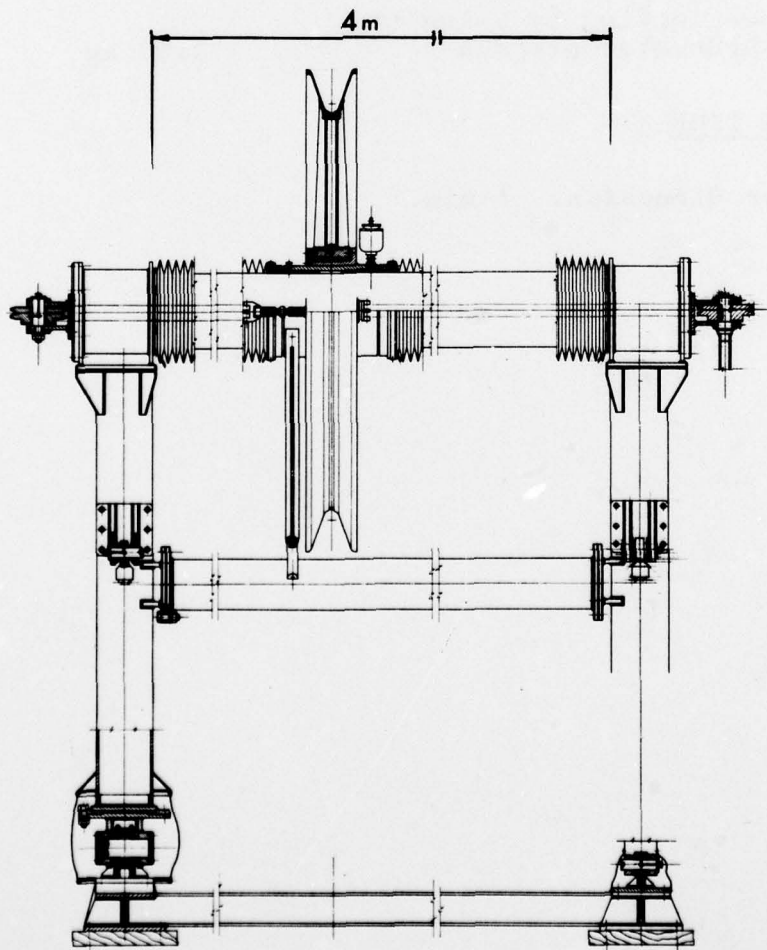
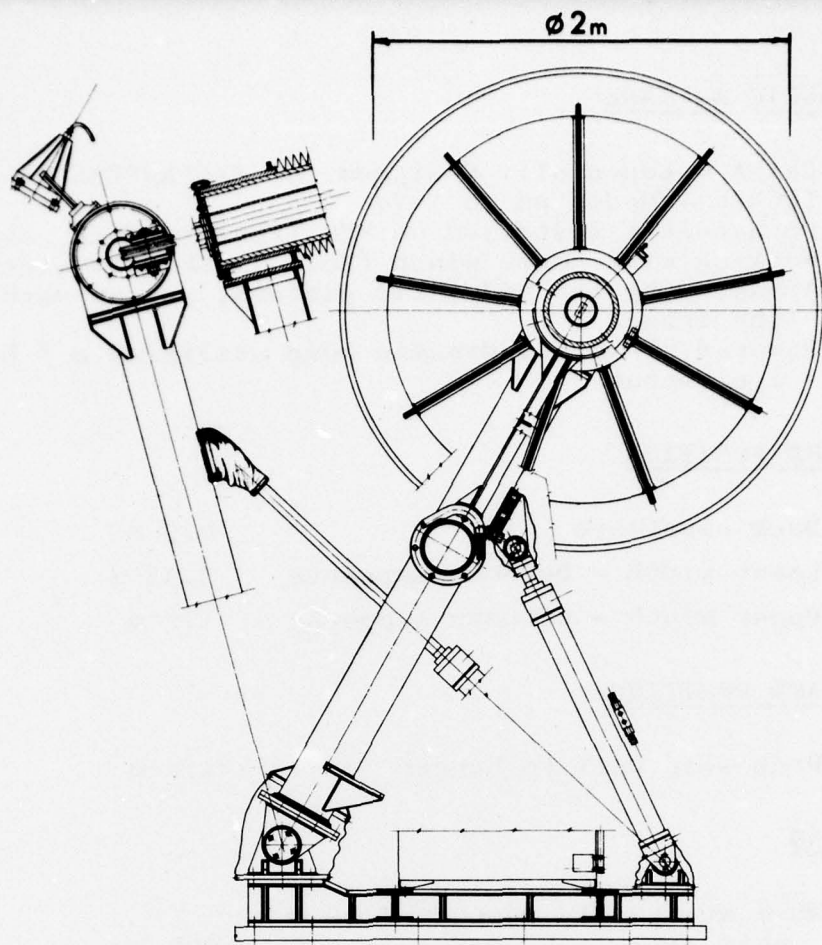

21. HYDRAULIC A-FRAME - CABLE GUIDE FOR DEEP VERTICAL ARRAY

- Designed by SAACLANTCEN
- Built by OLMEC in 1968
- Modified in 1970
- Can be installed on MPG (forward deck, starboard) when required
- Working with deep vertical array drum (No. 10)
- Actuated by two hydraulic pistons, one on each side of the stanchion
- Powered by an oil-dynamic pump utilizing a 12.5 h.p. a.c. motor. The sheave slides by means of a 1 h.p. a.c. motor with a 1:79.3 gear ratio.

OUTBOARD POSITION

- From ship rail to hanger 0.8 m

LOADING

- When statically supported 2500 kg
- When luffing by using the hydraulic pistons 1500 kg

LUFFING TIME

Either direction: 30 s.

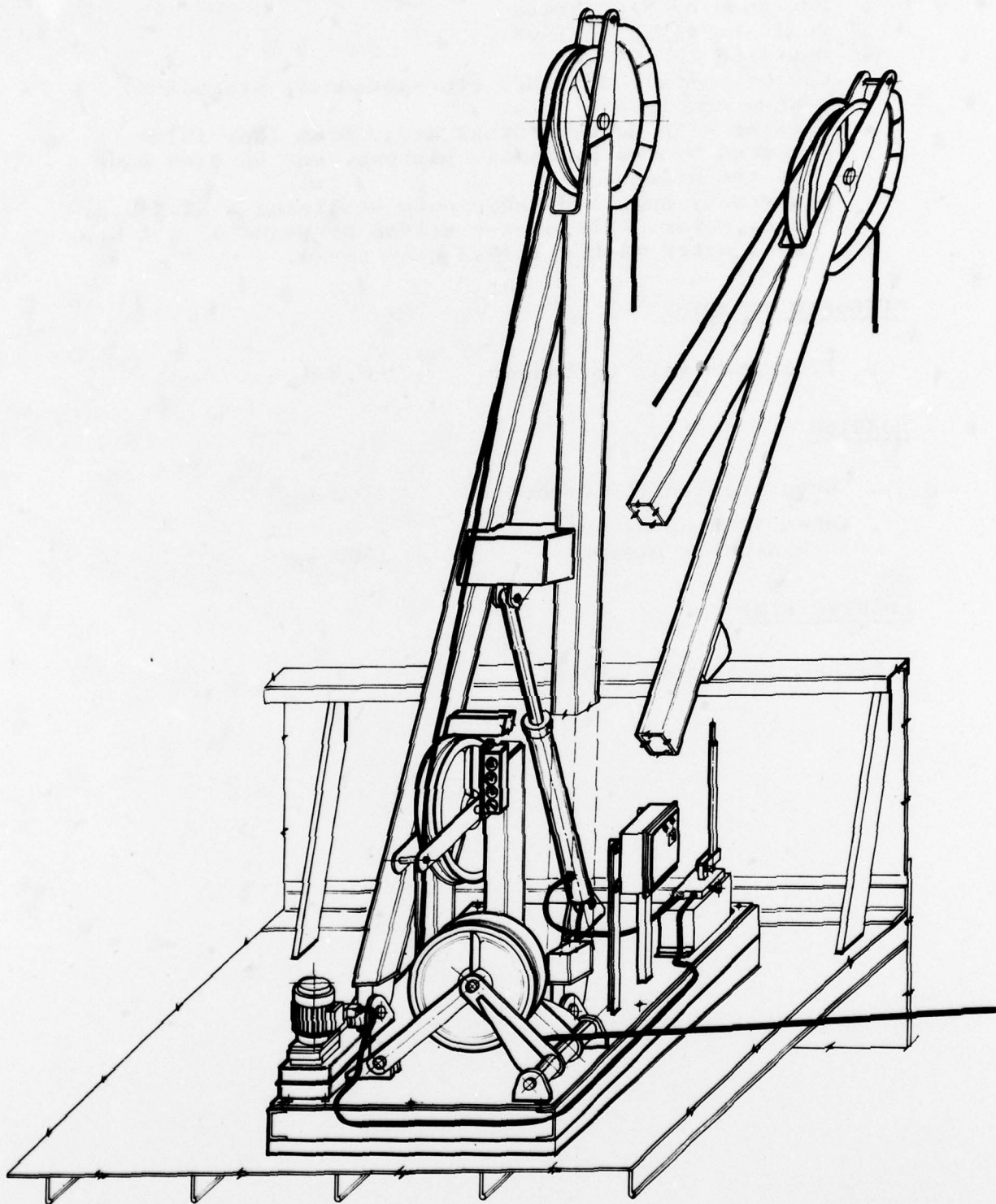

22-23.

DAVITS FOR HORIZONTAL ARRAY

- . LEBUS - Especially designed for SACLANTCEN
- . Can be installed on MPG (forward deck, port) when required
- . Working with LEBUS winches (Nos. 7 and 8)
- . Actuated by a single hydraulic piston, powered by an oil-dynamic pump utilizing a 2 h.p. a.c. motor

OUTBOARD POSITION

- . From ship rail to hanger 1.8 m

LOADING

- . When statically supported at ship rail 1800 kg
- . When luffing by using the hydraulic piston 900 kg

LUFFING TIME

Either direction: 20 s.

BACK VIEW

SIDE VIEW

DETAIL

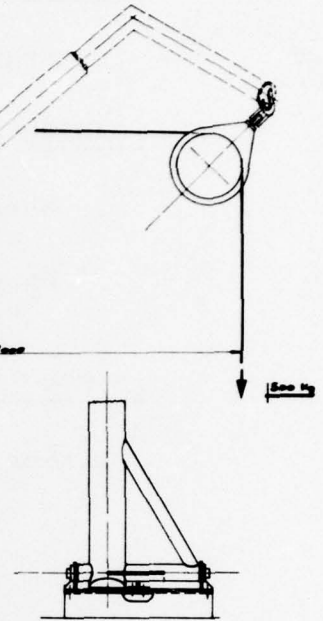
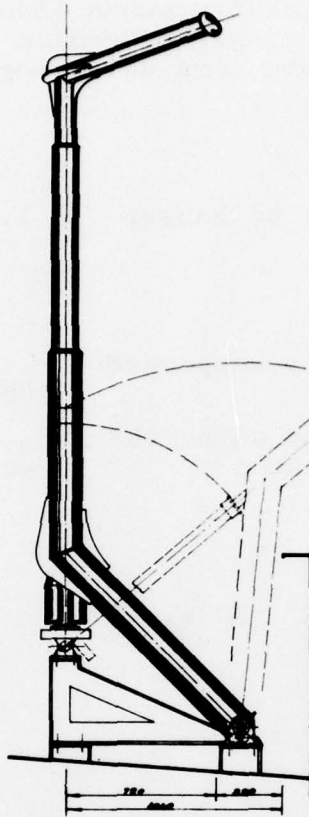
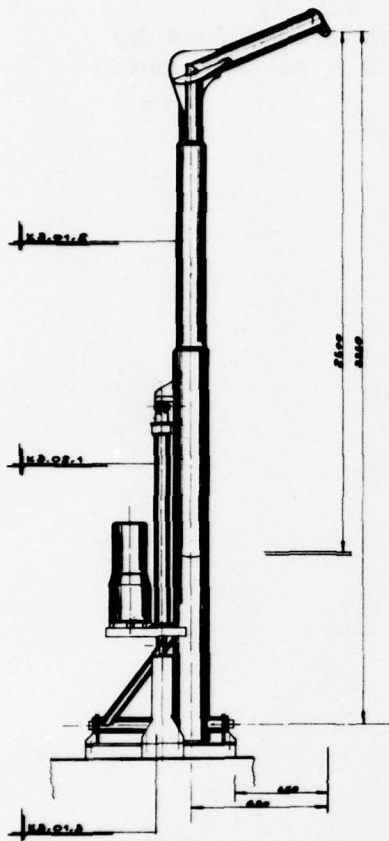

24. DAVIT FOR S.T.D.

- . Designed and built by SACLANTCEN in 1974
- . Can be installed on MPG (midships starboard) on the same base as the S.T.D. winch (No. 6) and working with it
- . Actuated by a servo-control
- . Powered by a 2 h.p. a.c. motor

INBOARD POSITION

- . Deck clearance 3.4 m

OUTBOARD POSITION

- . From ship rail to hanger 2 m

LOADING

- . Static or luffing 500 kg

LUFFING TIME

Either direction: 45 s.

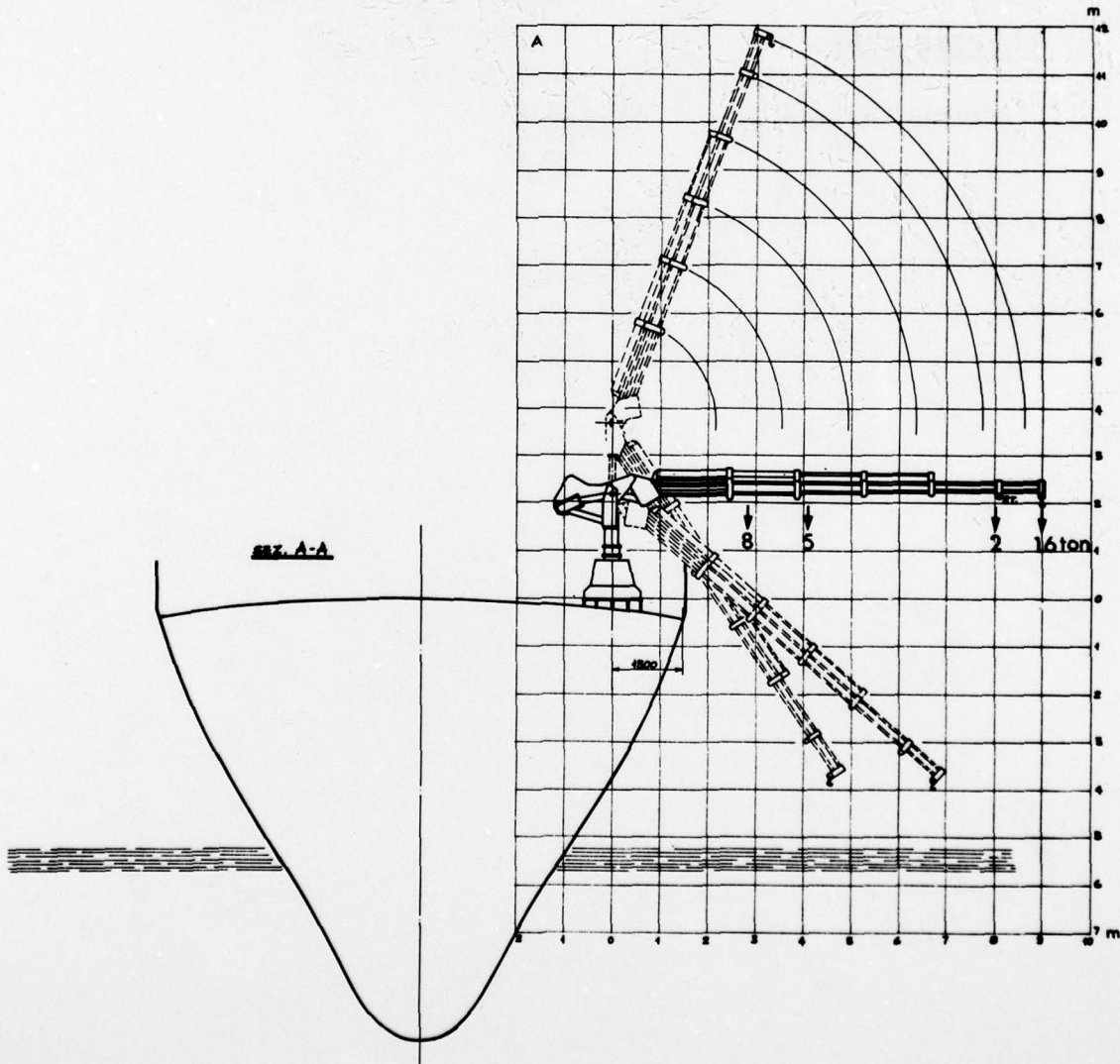
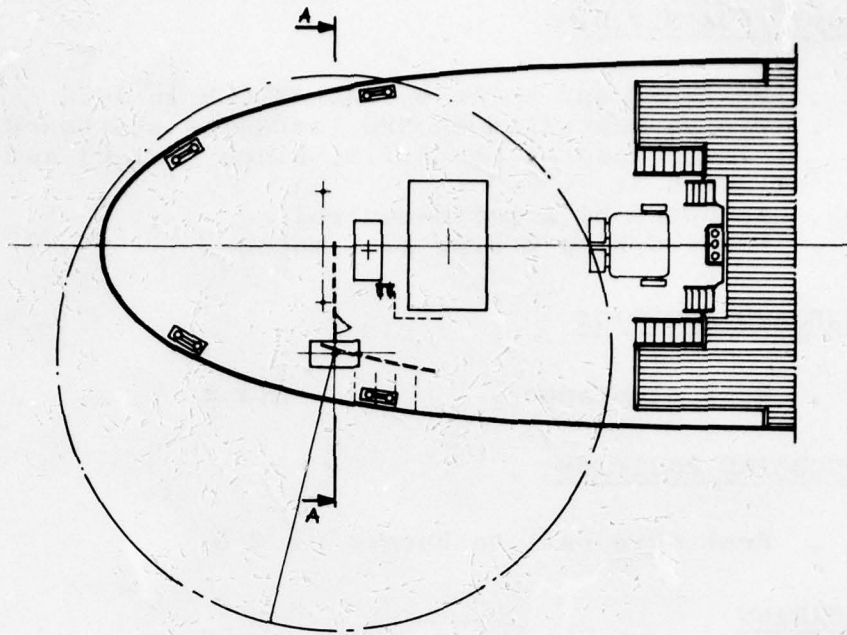

25. HYDRAULIC TELESCOPIC CRANE

- . PAGLIERO - Type OP 200L
- . Permanently installed on MPG (stern)
- . Used for launching and recovering oceanographic buoy, working with corer winch (No. 5), and with towed-fish winch (No. 9)
- . Actuated by three hydraulic pistons for extension and elevation, by two hydraulic motor driving a double helical worm gear for rotation, and equipped with a small hydraulic winch
- . Powered by an oil-dynamic pump utilizing a 20 h.p. a.c. motor

OPERATING POSITION

- . Maximum extension 9 m
- . Maximum elevation from deck 11 m
from sea level 15 m
- . Rotation 0° to 360°

LOADING

The static and dynamic working loads of the crane are shown opposite and overleaf.

TIMES

- . Rotation time 2 min
- . Extension time 75 s
- . Elevation time 65 s

WINCH

- . Pull and speed of wire winch: 2000 kg at 8 m/min.

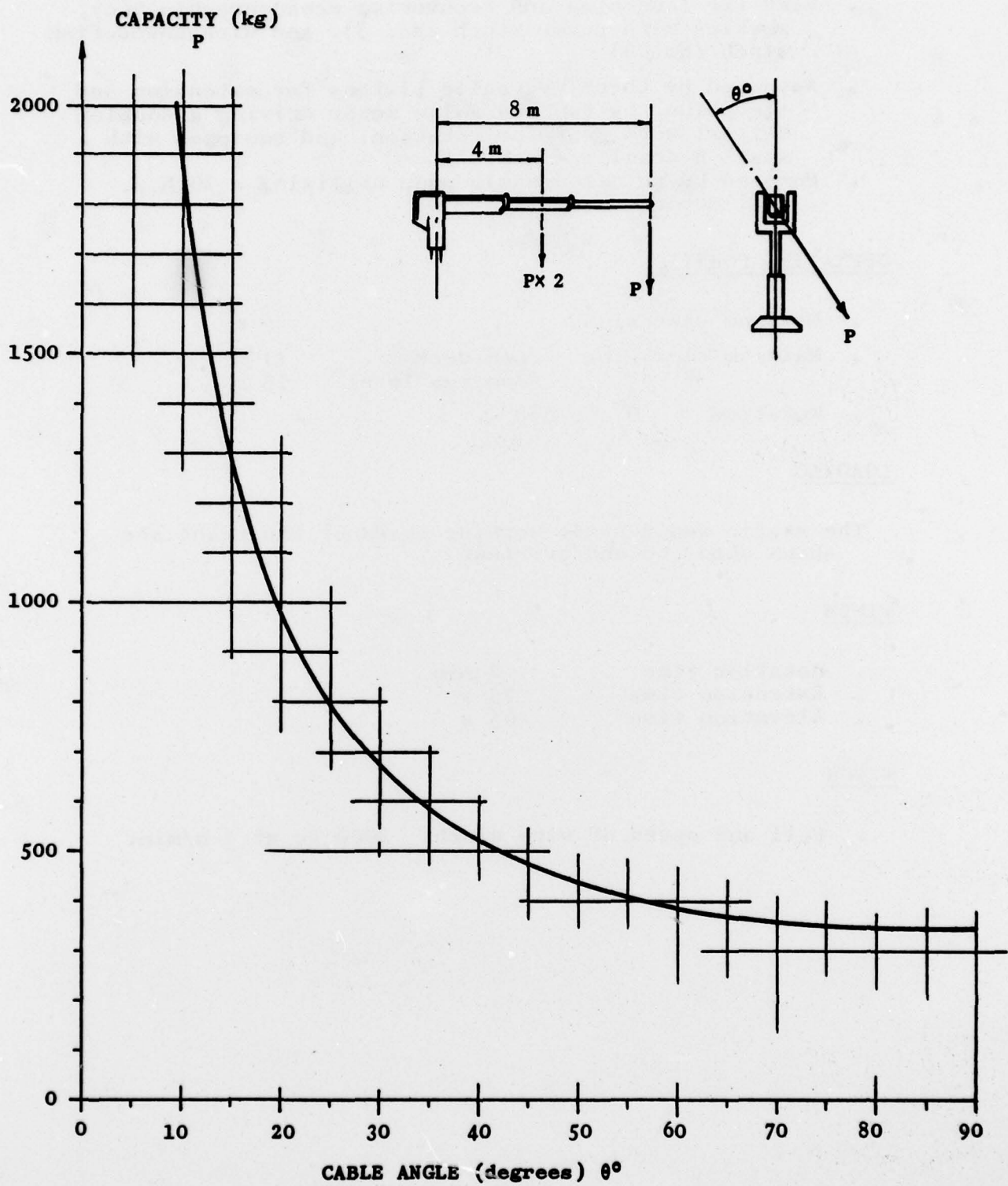

DYNAMIC WORKING LOAD OF HYDRAULIC TELESCOPIC CRANE (25):
CAPACITY AS FUNCTION OF CABLE ANGLE

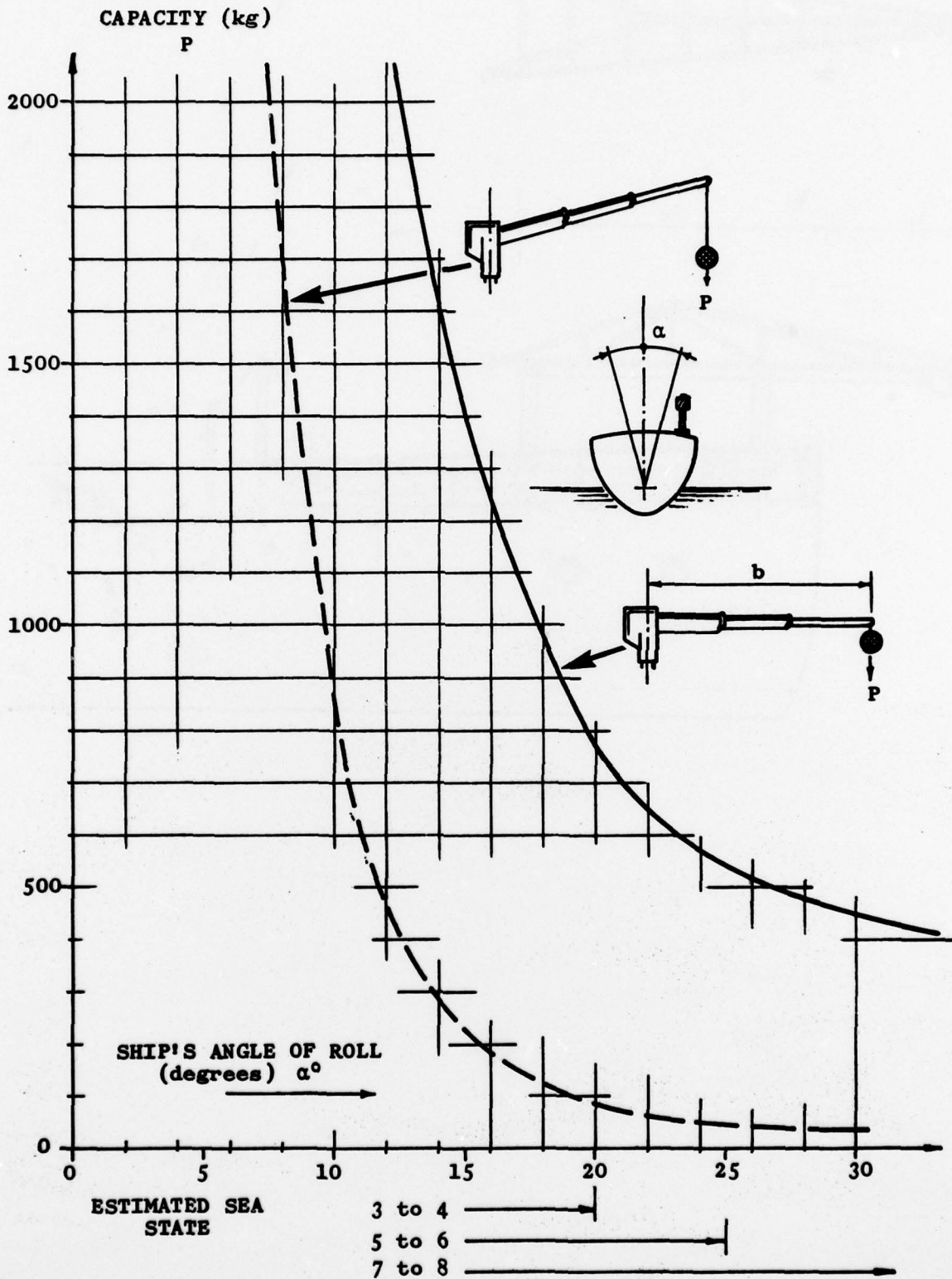

DYNAMIC WORKING LOAD OF HYDRAULIC TELESCOPIC CRANE (25):
CAPACITY AS FUNCTION OF SHIP'S ROLL

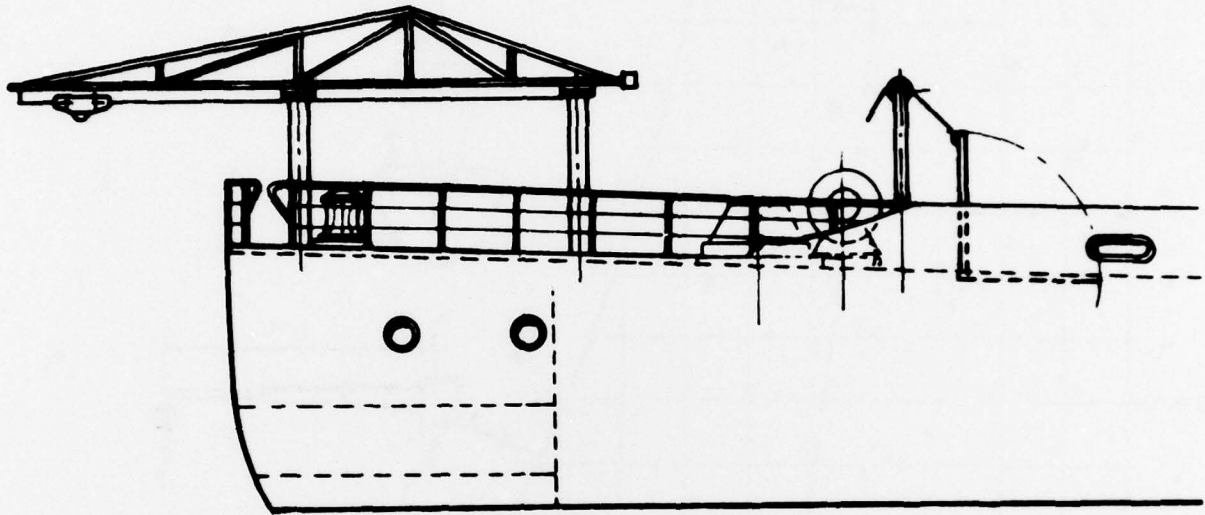
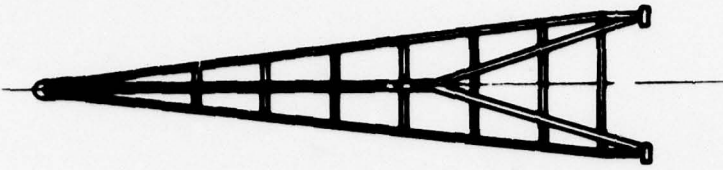

26.

OUTRIGGER FOR TOWED EQUIPMENT

- . TECMEL - Especially designed for SACLANTCEN in 1970
- . Can be installed on MPG (stern) when required
- . Working with corer winch (No. 5) and towed-fish winch (No. 9)
- . The hanger slides along the boom by means of a wire system driven by a 2 h.p. a.c. motor

POSITIONS

- . Inboard extension from rail 5 m
- . Outboard extension from rail 3 m

LOADING

- . With the load statically supported 1000 kg
- . With the load sliding 300 kg