

AD-A064 881

HUGHES RESEARCH LABS MALIBU CALIF  
PULSE MODULATOR BEHAVIOR OF THE LIQUID METAL PLASMA VALVE (LMPV--ETC(U)  
NOV 78 W WRIGHT, J R BAYLESS

F/G 9/1

N60921-76-C-0139

UNCLASSIFIED

DELET-TR-78-28

NL

| OF |  
AD  
A064881



END  
DATE  
FILMED  
4-79  
DDC



12  
NW **LEVEL II**

RESEARCH AND DEVELOPMENT TECHNICAL REPORT  
DELET-TR-78-28

ADA064881

PULSE MODULATOR BEHAVIOR OF THE LIQUID METAL PLASMA VALVE (LMPV)

W. Wright, Jr.

ELECTRONICS TECHNOLOGY & DEVICES LABORATORY

J. R. Bayless

HUGHES RESEARCH LABORATORY

DDC FILE COPY

November 1978

DISTRIBUTION STATEMENT  
Approved for public release;  
distribution unlimited.

DDC  
RECEIVED  
FEB 26 1979  
B

**ERADCOM**

US ARMY ELECTRONICS RESEARCH & DEVELOPMENT COMMAND  
FORT MONMOUTH, NEW JERSEY 07703

## NOTICES

### Disclaimers

The citation of trade names and names of manufacturers in this report is not to be construed as official Government indorsement or approval of commercial products or services referenced herein.

### Disposition

Destroy this report when it is no longer needed. Do not return it to the originator.

UNCLASSIFIED

SECURITY CLASSIFICATION OF THIS PAGE (When Data Entered)

<b>19</b> REPORT DOCUMENTATION PAGE		READ INSTRUCTIONS BEFORE COMPLETING FORM	
1. REPORT NUMBER <b>18</b> DELET-TR-78-28 ✓	2. GOVT ACCESSION NO.	3. RECIPIENT'S CATALOG NUMBER	
4. TITLE (and Subtitle) <b>6</b> Pulse Modulator Behavior of The Liquid Metal Plasma Valve (LMPV)		5. TYPE OF REPORT & PERIOD COVERED <b>9</b> Technical Report	
7. AUTHOR(s) <b>10</b> W. Wright, Jr. ET&DL, and J.R. Bayless, Hughes Research Lab.		8. CONTRACT OR GRANT NUMBER(s)	
9. PERFORMING ORGANIZATION NAME AND ADDRESS USA Electronics Technology & Devices Lab (ERADCOM) Fort Monmouth, N.J. 07703		10. PROGRAM ELEMENT, PROJECT, TASK AREA & WORK UNIT NUMBERS <b>16</b> 1L162705AH 94 02 G2 <b>17</b> G2	
11. CONTROLLING OFFICE NAME AND ADDRESS Beam, Plasma and Display Div US Army Electronics Technology and Devices Lab (ERADCOM) ATTN: DELET-BG		12. REPORT DATE <b>11</b> November 1978	
14. MONITORING AGENCY NAME & ADDRESS (if different from Controlling Office) <b>12</b> 9 P.		13. NUMBER OF PAGES 5	
16. DISTRIBUTION STATEMENT (of this Report)  Approved for public release; distribution unlimited.		15. SECURITY CLASS. (of this report)  Unclassified	
17. DISTRIBUTION STATEMENT (of the abstract entered in Block 20, if different from Report) <b>15</b> N60924-76-2-0439		15a. DECLASSIFICATION/DOWNGRADING SCHEDULE	
18. SUPPLEMENTARY NOTES			
19. KEY WORDS (Continue on reverse side if necessary and identify by block number) Pulse Power Closing Switch Mercury Cathode Megawatt Average Power Failure Mechanism			
20. ABSTRACT (Continue on reverse side if necessary and identify by block number)  See other side for Abstract			

272 600

Block #20

Abstract:

The LMPV is a mercury-cathode, triggered, closing switch which employs a small area mercury pool and a cooled (-30°C) condensing surface to maintain the conditions for vacuum arc operation. These conditions result in high-voltage capability, fast recovery and high current operation with negligible cathode wear. Therefore, the LMPV was considered to have potential as a high average power closing switch for modulator applications. An LMPV closing switch (LMPVCS) was built at Hughes Research Laboratories and evaluated at ERADCOM at voltages up to 150 kV, currents up to 8 kA peak and 7.5 A average, pulse lengths up to 50  $\mu$ s, and repetition rates up to 250 Hz. The device failed as a result of excessive anode dissipation caused by a long anode fall time on the order of 5  $\mu$ s. Subsequent experimentation has indicated that the fall time is reduced at increased mercury vapor pressures, however, experiments are required to define the relation between the fall time and voltage hold-off capability.

ACCESSION for	
NTIS	White Section <input checked="" type="checkbox"/>
DDC	Buff Section <input type="checkbox"/>
UNANNOUNCED	<input type="checkbox"/>
JUSTIFICATION	
BY	
DISTRIBUTION/AVAILABILITY CODES	
Dist.	U. and/or SPECIAL
A	

PULSE MODULATOR BEHAVIOR OF THE  
LIQUID METAL PLASMA VALVE (LMPV) \*

by

W. Wright, Jr.  
U.S. Army Electronics Technology and Devices Laboratory  
(ERADCOM)  
Fort Monmouth, New Jersey

and

J.R. Bayless  
Hughes Research Laboratory  
3011 Malibu Canyon Road  
Malibu, California 90265

Abstract

*microseconds*  
The LMPV is a mercury-cathode, triggered, closing switch which employs a small area mercury pool and a cooled (-30°C) condensing surface to maintain the conditions for vacuum arc operation. These conditions result in high-voltage capability, fast recovery and high current operation with negligible cathode wear. Therefore, the LMPV was considered to have potential as a high average power closing switch for modulator applications. An LMPV closing switch (LMPVCS) was built at Hughes Research Laboratories and evaluated at ERADCOM at voltages up to 150 kV, currents up to 8 kA peak and 7.5 A average, pulse lengths up to 50  $\mu$ s, and repetition rates up to 250 Hz. The device failed as a result of excessive anode dissipation caused by a long anode fall time on the order of 5  $\mu$ s. Subsequent experimentation has indicated that the fall time is reduced at increased mercury vapor pressures, however, experiments are required to define the relation between the fall time and voltage hold-off capability. *microseconds*

Table 1. LMPVCS Operating Goals

Parameter	Values		
Peak Charging Voltage (kV)	50	100	200
Pulse Width ( $\mu$ s)	20	50	50
Peak Current (kA)	8	8	4
Repetition Rate (Hz)	250	50	50
Average Current (A)	40	20	10
Average Power Delivered to Load (MW)	1	1	1
Run Time (min)	1	1	1
Minimum Off Time (min)	10	10	10

The major portion of the test program was undertaken at ERADCOM, Ft. Monmouth, New Jersey with the following conclusions:

1. A maximum average load power of 0.3 MW, which was limited by arc over in the PFN and current limitation of the high-voltage power supply, was achieved at a PFN charging voltage of 149 kV in 50  $\mu$ s pulsed operation. No misfires, electrical breakdown or current conduction in the reverse direction was observed under these conditions; and
2. The anode fall time was typically 5  $\mu$ sec. This led to severe power dissipation in the anode and to its eventual failure. Higher average powers would not be possible unless the fall time can be reduced.

Following failure of the LMPVCS, single pulse experiments were performed with a similar LMPV at HRL in an effort to reduce the anode fall time. A fall time of 200 nsec was achieved by increasing the condenser and cathode temperatures and thereby the pressure of mercury vapor. Although the voltage hold-off capability is thereby reduced, it is possible that a relation exists between fall time and voltage hold-off which would offer the capability for high-average-power, high-voltage operation. More experimentation is required to evaluate this possibility.

The LMPVCS

A block diagram of the LMPVCS system is shown in Figure 2. The LMPV, which is the central element of this system, is shown in Figure 3 as it's being prepared for bakeout.

Introduction and Summary

The increasing size and complexity of pulsed power systems is leading to the requirement for closing switches capable of higher average powers, peak currents and voltages while maintaining high reliability and compactness. There are, however, few candidate closing switches which hold the promise for reliable, long-life operation at average load powers in excess of 1 MW.

The objective of the liquid metal plasma valve closing switch (LMPVCS) program\*\* discussed herein has been to develop a new type of closing switch capable of meeting future requirements. This expected capability has been based on over ten years of development of the LMPV\*\*\* as a high-voltage dc converter valve and as a commutated dc interrupter. In these programs operation has been achieved at voltages over 200 kV, peak currents up to 40 kA and average currents over 600 A; this provided confidence that high average powers could also be achieved in relatively short pulse operation.

The objective was pursued by constructing and testing the LMPVCS shown in Figure 1. The test objectives, which are outlined in Table 1, were to use the LMPVCS to connect a PFN to a matched resistive load at an average load dissipation of 1 MW under a number of combinations of voltage, current and repetition rate. This power level was chosen to be consistent with existing test capabilities at ERADCOM while providing information concerning the scalability of the LMPVCS.

The LMPV consists of a liquid metal cathode, an anode, and a condenser. The cathode is fabricated from molybdenum and contains a narrow annular groove into which mercury is fed. When any combination of the three igniter electrodes, which are located at the periphery of the mercury surface, is pulsed, arc spots form on the inner and outer periphery of the cathode groove such that the arc power is distributed and cooling is maximized. The molybdenum is wetted by the mercury and the arc spots are anchored at the mercury-molybdenum interface, thereby eliminating droplet ejection and providing gravity independence. The cathode is water-cooled at a temperature of 20-30°C for which mercury vaporization from the small mercury surface area is minimal, and the anode temperature is maintained at ~ 50°C in order that mercury does not condense on it. The condenser is cooled to -30°C so that mercury vapor released from the cathode will condense on it. Thus, a low pressure is maintained and the valve operates in the vacuum arc mode. This results in a low voltage drop during conduction (~30 V) combined with high recovery rates and excellent insulation integrity. The use of this liquid metal cathode in which the arc spots are anchored and mercury evaporation is controlled eliminates the main problems associated with the conventional use of mercury as a discharge cathode.

Anode temperature control is provided by a liquid loop which recirculates Dowtherm at nominally 50°C through the anode at approximately 5 gal/min. High voltage isolation of the bulk of this subsystem, which is near ground potential, from the anode is provided by dielectric hoses and the excellent dielectric properties of the Dowtherm coolant. Instrumentation is provided to calorimetrically measure the thermal input to the anode.

The condenser temperature control system employs a 1-1/2 hp refrigeration unit and a recirculating R-11 liquid loop operating at 4 gal/min to maintain the condenser at approximately -35°C during off periods. The heat capacity of the condenser and cooling system is relied upon to absorb the short-term load during operation such that the temperature of the inner wall of the condenser rises to no more than -10°C; this corresponds to a mercury vapor pressure of 10<sup>-4</sup> Torr. Instrumentation is provided to permit calorimetric measurements of power input to the condenser.

Two redundant 8 %/sec Varian vac ion pumps are provided to exhaust outgassing products released during LMPVCS operation.

The cathode temperature control system serves to regulate the temperatures of the cathode, surfaces which surround the cathode, and the igniters.

The ignition subsystem supplies voltage pulses to the three semiconductor type igniters as well as to a mechanically actuated igniter which is used in the event that the semiconductor igniters do not operate properly (this never occurred).

The mercury supply system contains an externally pressurized bellows-type reservoir which releases mercury to the cathode by manual command. Because the amount of mercury evolved during one operating period is small in relation to the volume contained by the cathode, feeding is only required between runs.

A control system serves to indicate subsystem status and to disable the LMPVCS if any of the cooling systems malfunction.

#### Experimental Evaluation

The LMPVCS was initially operated at HRL primarily to condition the cathode by wetting it with mercury but also to verify its high voltage and EMI integrity. Conditioning was achieved by operating with low dc and ac voltages at average currents up to 350 A for an accrued time of about 30 min.

Testing at ERADCOM was performed using the circuit shown schematically in Figure 4. The high voltage power supply, charging resistor R<sub>c</sub>, and the PFN characteristics were changed during the test program in order to match the range of operating parameters. The load resistor, which employs a recirculating copper sulphate and acid solution, was matched to the PFN impedance to within ~ 10% except when the effects of mismatching were investigated. The capacitive voltage divider was used to measure the rapidly varying voltage at turn-on and the resistive divider to measure the more slowly varying waveforms. Current waveforms were measured by means of the current transformer.

The operating levels are summarized in chronological order in Table 2 where V is the PFN charging voltage, I is the peak current conducted to the matched load, τ is the current pulse width, f is the repetition rate, I<sub>AV</sub> is the average current delivered to the load, and T is the running time. The average current, which is calculated as I<sub>AV</sub> = Ifτ, is within 10% of the value measured using the power supply current meter.

The Sets 1-3 represent operation at up to 100 kV with the PFN and load resistance configured for impedances of 25, 12.5 and 6.25 Ω, respectively. The repetition rate was adjusted such as not to exceed the nominal maximum power supply current of ~ 5.0 A. In these tests, no misfires (failure to fire when triggered), prefires (breakdown in the absence of a trigger pulse) or current reversals (reverse current when the voltage swings negative) were observed. During testing at a PFN impedance of 6.25 Ω, a load resistance

Table 2. LMPVCS Operating Levels

DATA SET NO.	V, kV	I, kA	τ, μSEC	f, Hz	I <sub>AV</sub> , A	T, SEC
1	100	2.0	50	50	5.0	60
2	100	4.0	50	25	5.0	60
3	100	7.2	50	13	4.7	60
4	202	0	dc		0	120
5	127	2.4	50	36	4.3	60
6	138	2.7	50	32	4.3	60
7	149	2.9	50	30	4.4	15
8	53	3.8	20	50	3.8	60
9	15	1.0	20	250	5.0	60
10	53	3.8	20	100	7.6	35

of 5.2  $\Omega$  (20% mismatch) resulted in current reversals in only 20-30% of the conduction pulses. Figures 5 and 6 illustrate characteristic waveforms for the 50  $\mu$ sec, 6.25  $\Omega$  PFN configuration. The current rise time (refer to middle trace in Figure 5) of  $\sim 5$   $\mu$ sec is determined primarily by circuit parameters. The jitter was  $\sim 4$   $\mu$ sec, however, it is expected that this is associated with the relatively slow rise time of the igniter current pulse. The anode fall time, the time for the voltage across the LMPV to drop from 90% to 10% of its original value, was typically 5  $\mu$ s as shown in the lower trace of Figure 5 (it ranged from 3 to 10  $\mu$ sec). This time, which is determined by the physical processes within the LMPV, is much longer than had been anticipated on the basis of experiments under different conditions performed at HRL. As a result of the long fall time, the anode dissipation was large; it was 6.6 kW for Data Set No. 3. As seen from Figure 6, the voltage rate-of-rise after conduction is approximately 2.2 kV/msec for the operating voltage of 50 kV.

The voltage withstand tests outlined in Table 2 were performed with a current limiting resistance of 200  $M\Omega$  in series with the high voltage power supply. A voltage of 202 kV was reached within 80 min. and held for 2 min. with no activity.

Data Sets 5-7 represent the progression of operating conditions directed toward achieving high power operation at 200 kV. Performance of these tests was limited to 4.5A average by the high voltage power supply, to 149 kV by arc-over of the PFN, and to short run times by  $R_c$ . The LMPVCS operated at the higher voltages similarly to its operation at 100 kV; with few exceptions there were no prefires, misfires or current reversals. The maximum average load power reached in these tests was 0.33 MW; the peak power was 0.3 GW.

Data Sets 8-10 were obtained using a PFN-Power Supply assembly capable of supplying 70 kV, 10 kA peak and 50 A average in 10 or 20  $\mu$ sec pulses. The objective of these tests was to reach the operating levels described in the first column of Table 1. For repetition rates close to 50 Hz, the test results were similar to those obtained previously. At 50 kV and a peak conduction current of 4 kA, the anode fall time was  $\sim 4$   $\mu$ sec; times as low as 1.5  $\mu$ sec were occasionally observed. Calorimetric measurements of the power input to the condenser at 50 kV, 3.8 kA peak and 7.5 A average indicated that less than 4% of the total LMPV power dissipation was in the condenser; this is much less than the 30% measured for operation with 60 Hz ac. The dissipation in the cathode, also measured calorimetrically, was less than 1%. Thus, for an LMPV operating under short pulse conditions, more than 95% of the total dissipation is in the anode.

As the repetition rate was increased, misfiring began to occur; a misfire rate of approximately 5% was observed at 250 Hz with low average power.

When the average load power level was increased to 0.2 MW at 100 Hz (Data Set No. 10) electrical

breakdown of the interelectrode space occurred after  $\sim 30$  sec. The misfire rate was also sporadically high, however, no prefires or reverse current was observed. On the third attempt to operate at this level, the anode failed catastrophically and anode coolant was released into the interelectrode space. This terminated the testing.

The anode was subsequently removed from the LMPV for inspection. A spot approximately 1 cm in diameter, which was located on the anode face almost directly above the igniter in use at the time of failure, appeared to have been heated to its melting point. A narrow crack approximately 5 cm long passing through this spot was the source of coolant leakage. The high power concentration was probably due to the presence of an electron beam during the anode fall time which is emitted from arc spots localized near the igniter; presumably the arc spots do not spread significantly during the fall time.

Although brief attempts at ERADCOM to reduce the fall time met with little success, single pulse tests were subsequently undertaken with an identical LMPV at HRL with the objective of reducing the fall time. These tests were performed using a series L-C circuit which provided a current pulse waveform similar to that existing in the damaging ERADCOM tests. For the same LMPV parameters as used in the ERADCOM tests the fall time was, as before,  $\sim 5$   $\mu$ sec.

However, as the condenser temperature was varied from  $-40^\circ\text{C}$  to room temperature, the anode fall time decreased for temperatures above about  $0^\circ\text{C}$ . With both the condenser and cathode at room temperature, fall times of typically 0.2  $\mu$ sec were measured at voltages up to 38 kV, peak conduction currents up to 12 kA, current rates-of-rise up to 7 kA/ $\mu$ sec. The Paschen breakdown voltage under these conditions was  $\sim 45$  kV. This result indicates a significant relationship between mercury vapor density and the anode fall time. Further experimentation is necessary to determine the details of the relationships between temperature, fall time, and withstand voltage.

#### Footnotes

\* This work was performed under Naval Surface Weapons Center, Dahlgren Laboratory Contract No. N60921-76-C-0139 with support from the Air Force Aero Propulsion Laboratory, Defense Advance Research Agency, and US Missile Research and Development Command.

\*\* Bayless, J.R., and Heckl, J.P., "The Liquid Metal Plasma Valve Closing Switch," Proceeding of IEEE International Pulsed Power Conference, Lubbock, Texas, Nov. 9-11, 1976.

\*\*\* Eckhardt, W.O., U.S. Patent No. 3,659,132 (1972); G. Eckhardt and W.O. Eckhardt, "Liquid-Metal Plasma Valve Configuration," U.S. Patent pending.

THIS PAGE IS BEST QUALITY PRACTICABLE  
FROM COPY FURNISHED TO DDC



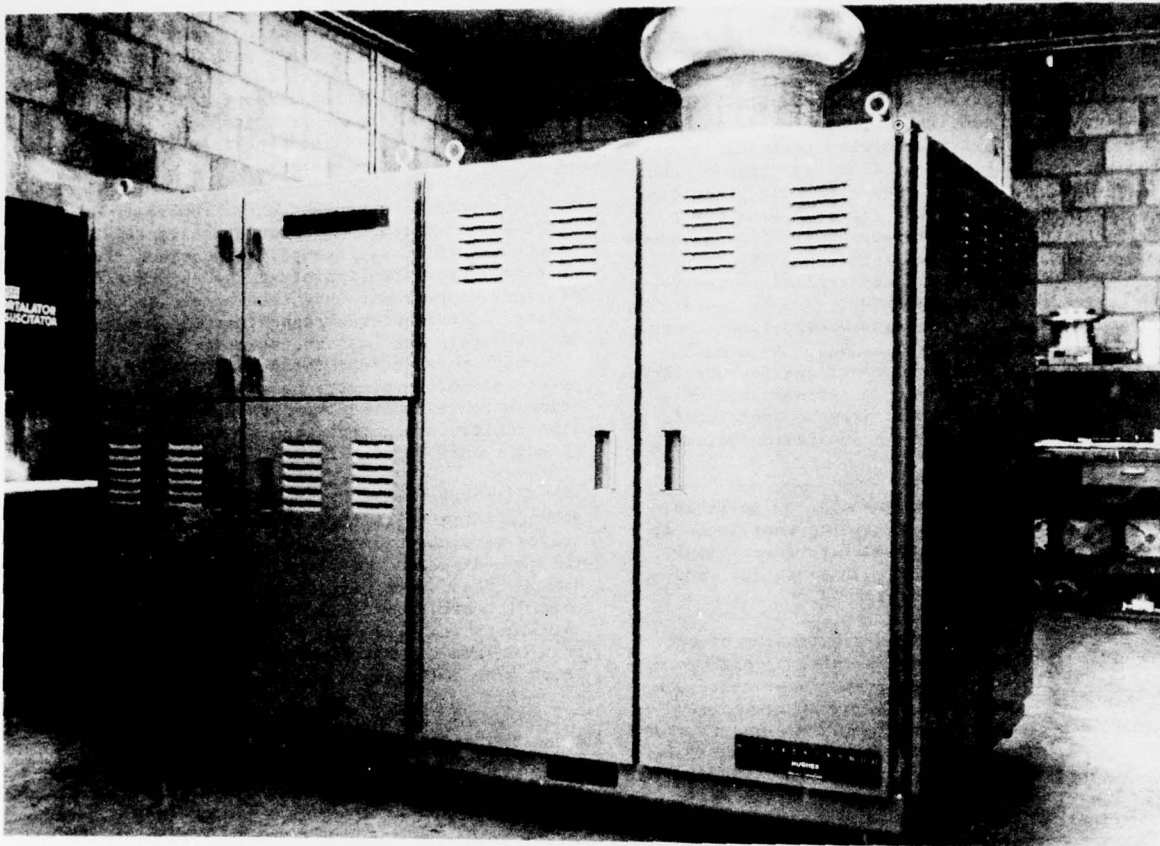

Figure 1. The LMPVCS

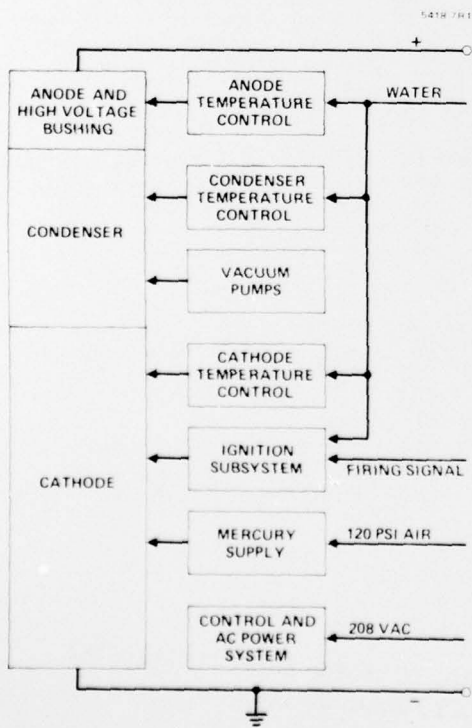

Figure 2. Block diagram of LMPVCS system.

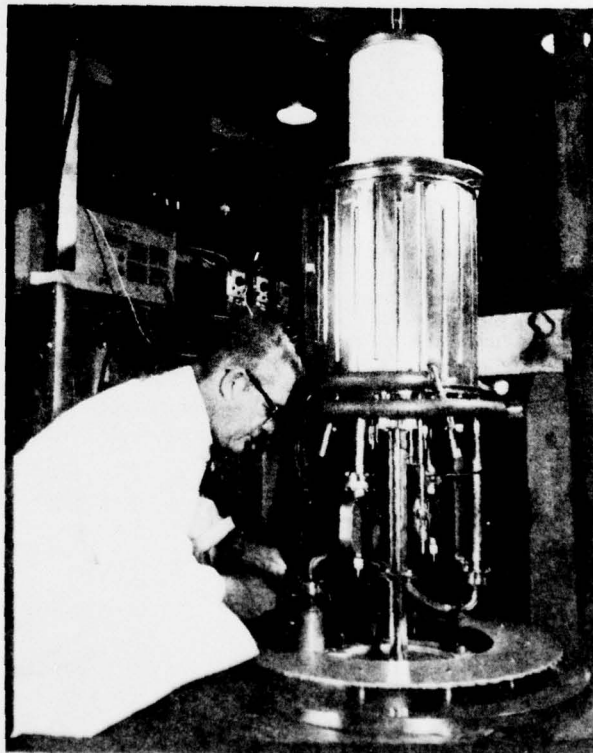

Figure 3. The LMPV being prepared for bakeout.

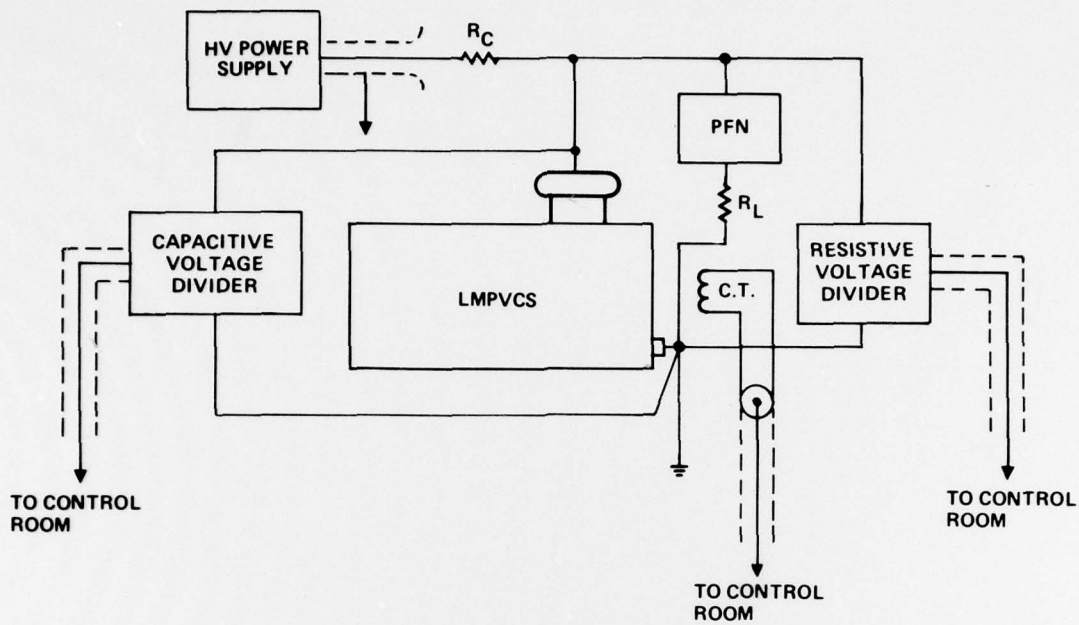

Figure 4. Schematic of test arrangement.

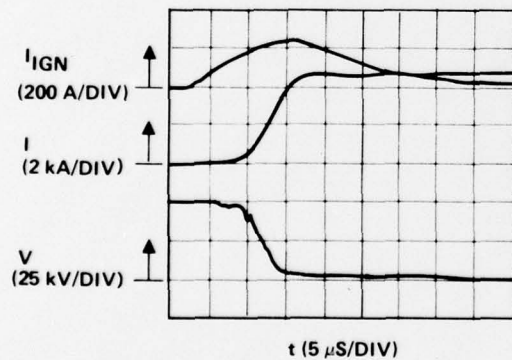

Figure 5. LMPVCS conduction waveforms. The top trace is the igniter current, the middle trace is the conduction current, and the lower trace is the anode voltage.

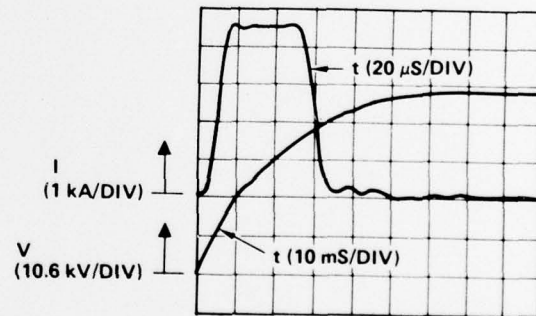

Figure 6. LMPVCS waveforms. The top trace is the conduction current and the lower trace is the anode voltage.

DEPARTMENT OF THE ARMY  
HEADQUARTERS

UNITED STATES ARMY

ELECTRONICS RESEARCH & DEVELOPMENT COMMAND  
FORT MONMOUTH, NEW JERSEY 07703

ATTN DELET-BG

OFFICIAL BUSINESS



POSTAGE AND FEES PAID  
DEPARTMENT OF THE ARMY

DOD-314

Hisa-FM-617-78