

AD-A064 300

ROYAL SIGNALS AND RADAR ESTABLISHMENT CHRISTCHURCH (E--ETC F/G 9/5  
A VOLTAGE-CONTROLLED ACTIVE LOW-PASS FILTER, (U)  
MAY 78 R C WESTON

UNCLASSIFIED

RSRE-78013

DRIC-BR-65965

NL

| OF |  
AD  
A064 300

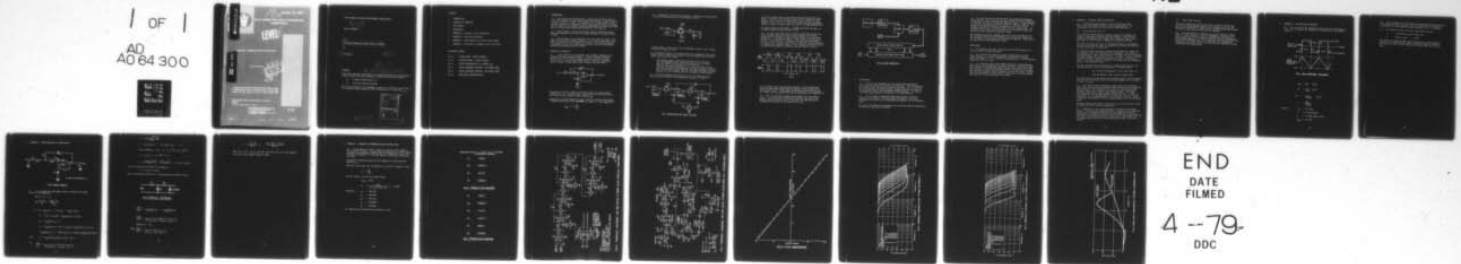

END  
DATE  
FILMED  
4--79  
DDC

REPORT No. 78013

ADA064300



REPORT No. 78013

ROYAL SIGNALS AND RADAR ESTABLISHMENT,  
CHRISTCHURCH.

**LEVEL 4**

A VOLTAGE - CONTROLLED ACTIVE LOW-PASS FILTER

DDC FILE COPY

Author: R C Weston

DDC  
RECEIVED  
FEB 7 1978  
RSRE

This document is the property of Procurement Executive, Ministry of Defence.  
Its contents should not be made public either directly or indirectly without  
approval from the Secretary of State for Defence (Director RSRE).

PROCUREMENT EXECUTIVE, MINISTRY OF DEFENCE  
RSRE

Christchurch, Dorset, England. BH23 4JB

This document has been approved  
for public release and sale; its  
distribution is unlimited.

May 1978

79 02 02 040

ROYAL SIGNALS AND RADAR ESTABLISHMENT (CHRISTCHURCH)

14  
RSRE-

Report No 78013

6  
"A VOLTAGE-CONTROLLED ACTIVE LOW-PASS FILTER"

by

10 R. C. Weston

12 23p.

11 May 78

18 DRIC 19 BR-65965

ABSTRACT

This report describes the design of a low-pass active filter of any desired order, in which the cutoff frequency is under the control of either:

- (a) A manual potentiometer, or
- (b) an active control potential.

The cutoff frequency can be arranged to operate on a linear law with respect to the active control potential, and can articulate at a rapid rate.

ACCESSION for	
NTIS	White Section <input checked="" type="checkbox"/>
DDC	Buff Section <input type="checkbox"/>
UNANNOUNCED	<input type="checkbox"/>
JUSTIFICATION	
BY	
DISTRIBUTION/AVAILABILITY CODES	
Disc	SPECIAL
A	

409807

LB

79 02 02 040

## CONTENTS

- I INTRODUCTION
- 1 PRINCIPLE OF OPERATION
- 2 TEST RESULTS
- 3 CONCLUSIONS
- 4 APPENDIX A - Detailed circuit description
- 5 APPENDIX B - Duty-cycle modulator
- 6 APPENDIX C - Brief analysis of active filter design
- 7 APPENDIX D - Selection of component values for filter

## ADDITIONAL FIGURES

- FIG 10 FILTER PANEL - CIRCUIT DIAGRAM
- FIG 11 SWITCHING PANEL - CIRCUIT DIAGRAM
- FIG 12 FILTER CHARACTERISTIC ( $f_o$  AGAINST  $V_{in}$ )
- FIG 13 TYPICAL FREQUENCY RESPONSE - 4TH ORDER FILTER
- FIG 14 TYPICAL FREQUENCY RESPONSE - 6TH ORDER FILTER
- FIG 15 GROUP-DELAY CHARACTERISTICS

## I INTRODUCTION

I.1 The principle described herein, in which the effective values of resistive-elements are controlled by switching networks at high frequency, is novel as far as is known. The employment of a diode bridge for this purpose represents an arrangement that was used extensively in the design, (by the author) of an adaptive equaliser (SRDE Report No 75009), and forms part of British Patent Application No 29444/72, (R C Weston).

I.2 This, however, is the first instance known in which the concept has been employed to articulate the cutoff frequency of low-pass active filters.

I.3 The principle can be extended to cover any order of active filter employing unity-gain voltage-followers, up to at least 10th order. However, the effect of the tolerances of resistors and capacitors becomes increasingly critical for orders greater than 6, as do the internally-generated potentials within the filter.

## 1 PRINCIPLE OF OPERATION

1.1 Active filters can be designed, (for low-pass, high-pass etc) around unity-gain voltage-followers. A typical low-pass 2nd order section of an active filter designed on these principles is shown below in FIG 1. Such sections (with specific values of components) can be cascaded to form higher-order filters up to 10th order.

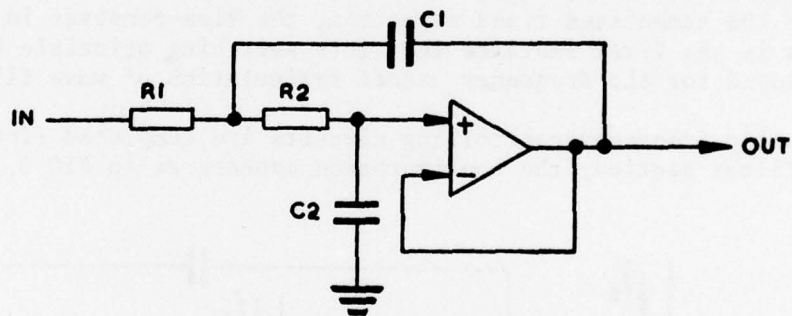

FIG. 1

The values of R1, R2, C1 and C2 can be such that for a given cutoff frequency  $R1 = R2 = 10 \text{ Kohms}$  (say). This results in particular values of C1 and C2 for a selected cutoff frequency  $f_{01}$ .

Change of the cutoff frequency to  $f_{02}$  can then be effected conveniently by CHANGING THE VALUE OF ALL RESISTORS, (in gang) to a value  $R_{NEW}$  where

$$R_{NEW} = R \frac{f_{01}}{f_{02}}$$

1.2 Variation of the effective R values, (in gang) has been achieved by using switching networks as shown below in FIG 2.

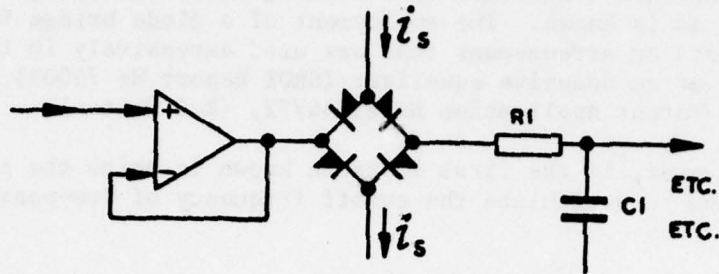

FIG. 2

A diode-bridge is connected to the low-impedance output of the voltage-follower and feeds on via  $R_1$ .

If a reversing current ( $i_s$ ) of square-wave form is applied to the diode-bridge, then the effective resistance of  $R_1$  will depend upon the duty-cycle (on/off) for the bridge.

For example, suppose that the on/off ratio is 50 on/50 off. Then the AVERAGE current flowing through  $R_1$  will be halved. Thus the effective resistance of  $R_1$  is now  $2.R_1$ . Therefore the cutoff frequency of the filter is halved, (since with the associated fixed capacitor, the time-constant is doubled). This is the first instance that this switching principle has been employed for the frequency cutoff articulation of wave filters.

1.3 When the frequency-controlling circuits are completed (for a 2nd-order filter section) the configuration appears as in FIG 3.

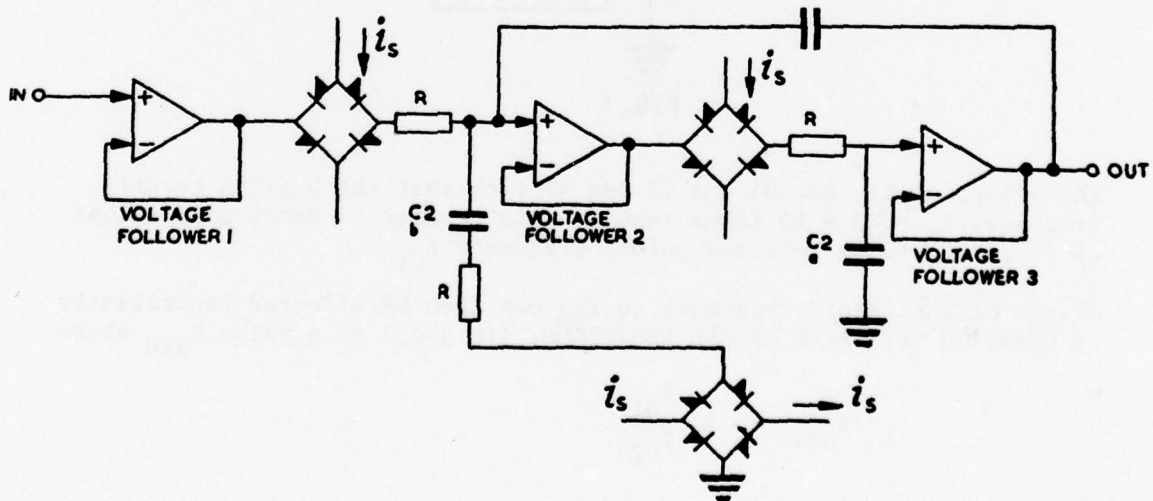

FIG. 3 ARTICULATORY 2ND ORDER SECTION.

It will be noticed that an intermediate voltage-follower has been added, to provide a low-impedance capability for driving the R/C2a network. Also, in order to preserve the effect of R2/C2 in shunt across R1 (as in FIG 1), an additional network and switching-bridge, (C2b/R) to earth, is shown across the input of voltage-follower No 2.

All diode-bridges are switched at a COMMON DUTY-CYCLE and RATE, ie in GANG by similar switch-driving circuits.

1.4 In order that there can be a linear relationship between the control-voltage input and filter cutoff frequency, the control voltage must be arranged to have a linear control on the switching duty cycle. In the present design, a ramp waveform is generated at 100 kHz. This waveform is adjusted to operate accurately between + 10 volts and - 10 volts, and to this is added the control potential. By clipping this composite signal at zero voltage, the desired control of duty-cycle-switching is obtained, (as shown below in FIG 4).

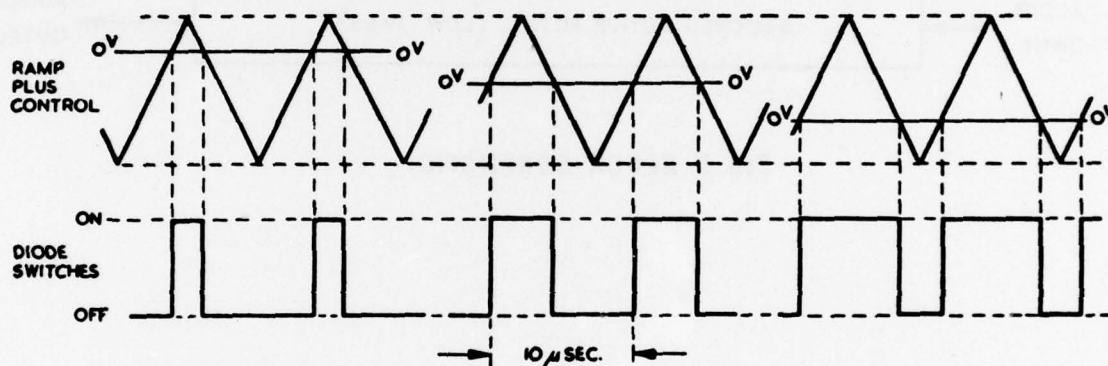

FIG. 4

It is desirable that the switching frequency of the diode-bridges should be some orders higher than the maximum cutoff-frequency for the low-pass filter. The maximum cutoff-frequency has been designed at 5.0 kHz, and this applies when the diode-switches are permanently on.

1.5 FIG 5 illustrates a simple Block Schematic for the complete filter. 4th and 6th order Butterworth responses were chosen and, using a common resistance value of 10 Kohms, the capacitors were evaluated as indicated in the Appendices C and D.

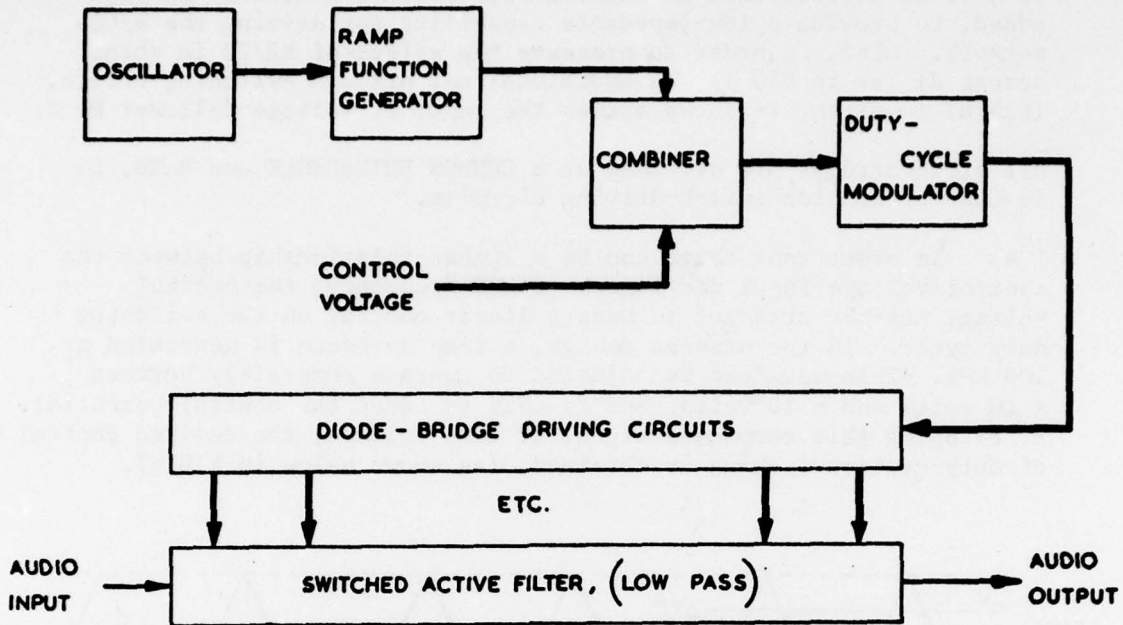

FIG.5 BLOCK SCHEMATIC.

## 2 TEST RESULTS

2.1 Circuits were assembled for 4th and 6th order Butterworth active filters, and the 3 dB points were measured, ( after setting up), for various values of control voltage in the range - 10 to + 10 volts. FIG 12 illustrates the characteristic obtained, and this was found to be essentially linear from the maximum cutoff-frequency, (5.0 kHz at + 10 volts control) down to 150 Hz (at - 9.4 volts control).

2.2 In the earlier experimental model some spurious tones were detected in the output. This was finally discovered to be due to conditional oscillation of the ramp-function generator in the switching unit.

As soon as the ramp-function generator was stabilised against oscillation, all spurious tones were eliminated.



2.3 For each filter (4th and 6th order) the attenuation/frequency characteristics were measured at various settings of control potential. In each case the control voltage was adjusted to give a 3 dB attenuation at frequency intervals from 500 Hz in steps of 500 Hz to 5000 Hz. The complete attenuation/frequency characteristics (for each control potential setting) are recorded in FIGS 13 and 14, respectively. The recorded results concur very closely with the theoretical values for 4th and 6th order low-pass Butterworth design.

The attenuation gradient (maximum) was found to be 23.9 dB/octave for the 4th order filter and 36.0 dB/octave for the 6th order filter, at all settings of cutoff frequency from 500 Hz to 5000 Hz. These results are very close to the theoretical values.

### 3 CONCLUSIONS

3.1 An effective method for controlling the cutoff-frequency of a low pass filter has been described.

3.2 The circuits were found to operate satisfactorily with the cutoff frequency in a linear relationship to the control voltage, within the range - 9.4 to + 10 volts, corresponding to a cutoff frequency range from 150 Hz to 5 kHz.

3.3 It is proposed that a more elegant method for controlling the duty-cycle of the diode-bridge circuits would employ a digital arrangement, whereby a fast-operating clock frequency and counter could vary the duty-cycle of the diode-switching circuits in fine, discrete steps. This proposed re-design could be achieved in the near future. Arrangements are being made for later models of the filter to include digital articulation of cutoff frequency as an option.

A APPENDIX A - DETAILED CIRCUIT DESCRIPTION

A.1 FIG 10 shows the complete circuit of the filter panel. FIG 11 shows the complete circuit of the switching panel. For convenience, the circuit of FIG 11 will be discussed first.

A.2 Switching Panel (FIG 11)

The oscillator (4093) employs a Schmidt trigger with feedback via a pair of resistors, (one fixed and one variable). This circuit produces a square-wave logic output, (not necessarily equal on/off duty cycle ). This circuit is adjusted to operate at 200 kHz.

The output from the oscillator is frequency-divided by the bistable-divider and produces an output of square-wave at exactly 100 kHz with an equal duty-cycle (50 on/50 off).

The resulting square waveform is passed via a capacitor to remove the dc component, and is then applied to the integrator. The output of this integrator is thus a ramp function at 100 kHz, and this is adjusted to operate between the limits of + 10 to - 10 volts. In order to ensure that this waveform is exactly balanced with respect to 0 potential, there is included a feedback resistor of 150 K ohms from the integrator output to the integrator input.

The ramp waveform from the integrator is summed resistively with the control potential. This control potential is obtained either,

- a via a 10-turn potentiometer on the front panel, or
- b from the "Remote" input control voltage socket.

Both these inputs are developed via a voltage follower. RV5 is adjusted to ensure that the limits of the 10-turn potentiometer RV7 are exactly + 10 to - 10 volts.

A.3 Thus the input to the comparator causes this unit to develop a square wave output, whose duty-cycle depends upon the control potential. This waveform is then interfaced into a pair of cascaded inverting-buffers, (4049) via a resistive and clamping circuit. The phase-splitting switch driver comes on when supplied with a "1" - state and causes  $\bar{R}$  to fall by approximately 5 volts from the + 15 rail, and causes  $\bar{S}$  to rise by approximately 5 volts from the - 15 rail. These 2 waveforms are connected to all the diode-bridge drivers in the filter-panel.

Variable resistors RV3 and RV4 are used to set up the duty-cycle limits as "gain" and "bias" controls respectively.

A.4 Indication of the cutoff-frequency is provided by the meter circuit. The duty-cycle waveform is used to switch an n-p-n transistor circuit and the resulting current-pulses are summed by the meter. Adjustment of the meter-sensitivity is by RV6 and this is set to give a full-scale meter deflection with the duty-cycle at 100 percent "on". In the present model the meter has been calibrated in kHz, from zero to 5.0 kHz.

#### A.5 Filter Panel (FIG 10)

Operational amplifiers type 741 are used in the main active filter circuit, since the maximum frequency to be passed is 5.0 kHz, and since these amplifiers are stable in the voltage-follower mode without the need for any external stabilisation components.

A.6 Each diode-bridge is connected to one of 9 identical bridge-drivers. These consist of a pair of complementary transistors in such a circuit as to pass a constant conduction current through the diode-bridge whenever a "1" state is supplied from the phase-splitting switch in the switching panel. At other times the complementary transistors are cutoff, and 47 K ohm resistors are connected as shown to back-bias the diode-bridges.

B APPENDIX B - THE DUTY-CYCLE MODULATOR

B.1 The circuits of the integrator should be easily understood, but first, let us consider the evaluation of components for the feedback-circuits.

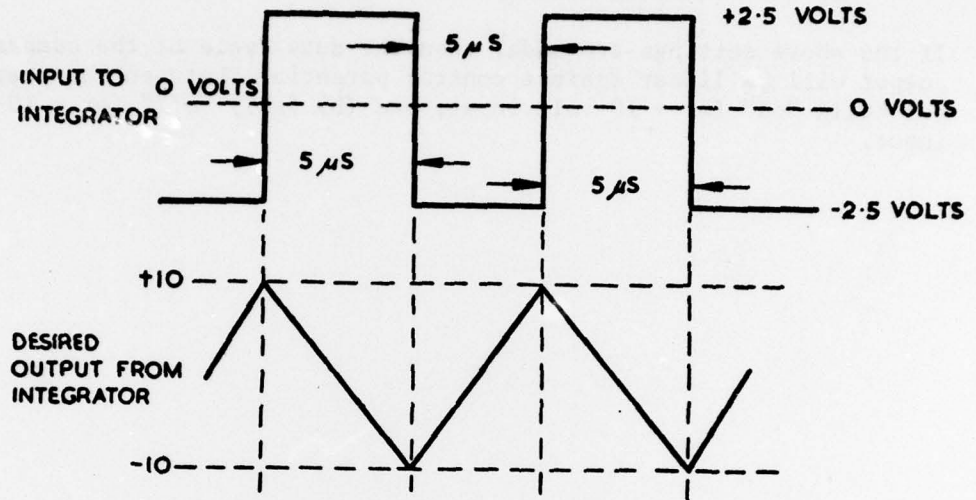

FIG. 6 IDEAL WAVEFORMS - INTEGRATOR.

$$V_{OUT} = \frac{1}{CR} V_{IN}.dt$$

$$RC = \frac{1}{V_{OUT}} V_{IN}.dt$$

$$\text{or } C = \frac{1}{R.V_{OUT}} V_{IN}.dt$$

$$C = \frac{V_{IN}.t}{R.V_{OUT}}$$

where:-

$$V_{IN} = 2.5 \text{ volts}$$

$$t = 5 \text{ microseconds}$$

$$R = 5 \text{ K ohms (mean value)}$$

$$V_{OUT} = 20 \text{ volts}$$

B.2 Once the frequency of the input square-waveform has been adjusted to be exactly 100 kHz, then RV2 is set to provide the full excursion of potential for the integrator output waveform (+ 10 to - 10 volts).

B.3 The comparator input circuits are provided with both,

- a. a sensitivity control (RV3), and
- b. a bias control (RV4).

If the above settings are made, then the duty cycle of the comparator output will be linear against control potential, between the states (a) fully "on" for + 10 volt input, and (b) fully "off" for - 10 volt input.

C. APPENDIX C - BRIEF ANALYSIS OF FILTER DESIGN

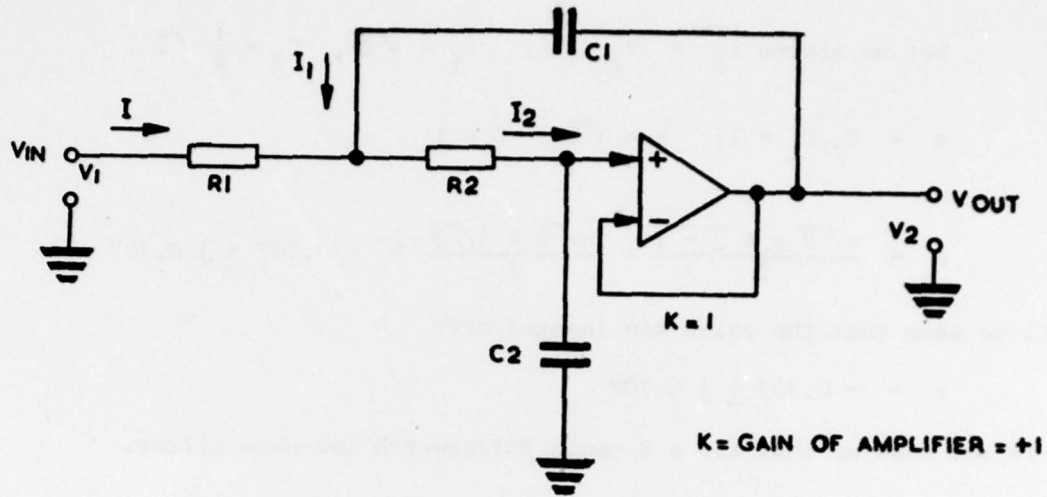

FIG. 7 BASIC CIRCUIT.

C.1 It is assumed that negligible current is taken by the input circuit of the amplifier.

$$\text{Then } I + I_1 = I_2$$

$$\text{Thus } \frac{V_1 - V_2}{R_1} + \frac{V_{\text{OUT}} - V_2}{1/sC_1}$$

$$V_1 - V_2 + V_{\text{OUT}} \cdot s \cdot C_1 - V_2 \cdot s \cdot C_1 \cdot R_1 = V_{\text{OUT}} \cdot s \cdot C_2 \cdot R_1$$

$$V_1 = V_2(1 + s \cdot C_1 \cdot R_1) + V_{\text{OUT}}(s \cdot C_2 \cdot R_1 - R_1 \cdot s \cdot C_1)$$

$$V_2 = V_{\text{OUT}}(R_2 \cdot s \cdot C_2 + 1)$$

$$V_1 = V_{\text{OUT}}(R_2 \cdot s \cdot C_2 + 1)(1 + s \cdot C_1 \cdot R_1) + V_{\text{OUT}}(s \cdot C_2 \cdot R_1 - R_1 \cdot s \cdot C_1)$$

$$= V_{\text{OUT}}(R_2 \cdot s \cdot C_2 + 1 + s^2 R_2 \cdot C_2 \cdot R_1 \cdot C_1 + s \cdot C_1 \cdot R_1) + V_{\text{OUT}}(R_1 \cdot s \cdot C_2 - R_1 \cdot s \cdot C_1)$$

$$\text{Thus } V_1 = V_{\text{OUT}}(s^2 R_2 \cdot C_2 \cdot R_1 \cdot C_1 + s \cdot C_2 R_1 + R_2) + 1$$

$$\text{or } \frac{V_{\text{OUT}}}{V_{\text{IN}}} = \frac{1}{s^2 R_2 \cdot C_2 \cdot R_1 \cdot C_1 + s \cdot C_2 (R_1 + R_2) + 1}$$

$$s = \frac{-b + \sqrt{b^2 - 4ac}}{2a}$$

$$a = R_2 \cdot C_2 \cdot R_1 \cdot C_1, \quad b = C_2(R_1 + R_2) \quad c = 1$$

$$\text{Let us assume } R_1 = R_2 = 1, \quad C_1 = \sqrt{2}, \quad C_2 = \frac{1}{2} \sqrt{2}.$$

$$a = C_2 \cdot C_1 = 1; \quad b = \sqrt{2}; \quad c = 1$$

$$s = \frac{-\sqrt{2} \pm \sqrt{2 - 4}}{2} = \frac{-\sqrt{2} \pm j\sqrt{2}}{2} = -0.707 \pm j 0.707$$

It will be seen that the poles are located at:-

$$s = -0.707 \pm j 0.707$$

which is the same as that for a 2-pole Butterworth low-pass filter.

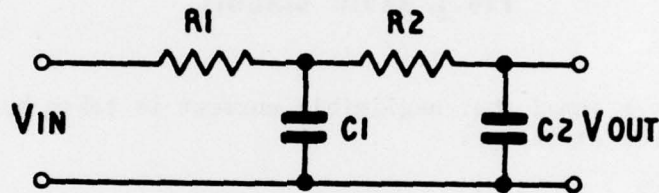

### R.C. PASSIVE NETWORK

$$\frac{V_2(s)}{V_1(s)} = \frac{1}{(s \cdot C_1 \cdot R_1 + 1)} \cdot \frac{1}{(s \cdot C_2 \cdot R_2 + 1)}$$

$$\frac{V_2(s)}{V_1(s)} = \frac{1}{s^2 C_1 \cdot R_1 \cdot C_2 \cdot R_2 + s(C_2 \cdot R_2 + C_1 \cdot R_1) + 1}$$

$$\text{Suppose } R_1 = R_2$$

$$\text{Then } \frac{V_2(s)}{V_1(s)} = \frac{1}{s^2 C_1 \cdot C_2 + s(C_1 + C_2) + 1}$$

$$s = \frac{-C_1 + C_2}{2C_1 \cdot C_2} \pm \frac{(C_1 + C_2)^2 - 4C_1 \cdot C_2}{2C_1 \cdot C_2}$$

Hence  $(C_1 + C_2)^2 > 4C_1 \cdot C_2$ , and hence the poles will lie on the negative real axis of the complex frequency plane.



D APPENDIX D - SELECTION OF COMPONENT VALUES FOR THE FILTER

D.1 The procedure is first to select the type of filter required and the number of poles. Filter tables are available for various types, including the Butterworth response, which are normalised to give 3 dB attenuation (cutoff) at  $\omega = 1.0$ , and assume a resistance, per section, of 1 ohm.

The specific normalised value for each capacitor is taken from the tables as  $C_s$ .

The actual value used, (as calculated for  $f_o$  and  $R = 10$  Kohms) is thus

$$C_A = \frac{C_s}{\omega_o R}$$

From the tables:- (for the 6th order filter)

$$C_{1(s)} = 1.035$$

$$C_1 = \frac{1.035}{2\pi \times 5.0 \times 10^3 \times 10^4} \text{ F} = 3294\text{pF}$$

Similarly:-

$$C_2 = 3074.8\text{pF}$$

$$C_3 = 4500.9\text{pF}$$

$$C_4 = 2507.7\text{pF}$$

$$C_5 = 0.012296 \text{ F}$$

$$C_6 = 823.78\text{pF}$$

All components are selected to an accuracy of  $\pm 1\%$ .

NORMALISED VALUES -  $R = 1, \text{OHM}$ ;  $\omega = 1.0 \text{ RAD/SEC.}$   
(BUTTERWORTH RESPONSE.)

C1	1.082 F
C2	0.9241 F
C3	2.613 F
C4	0.3825 F

FIG. 8 4<sup>TH</sup> ORDER FILTER CAPACITORS.

C1	1.035 F
C2	0.9660 F
C3	1.414 F
C4	0.7071 F
C5	3.863 F
C6	0.2588 F

FIG. 9 6<sup>TH</sup> ORDER FILTER CAPACITORS.

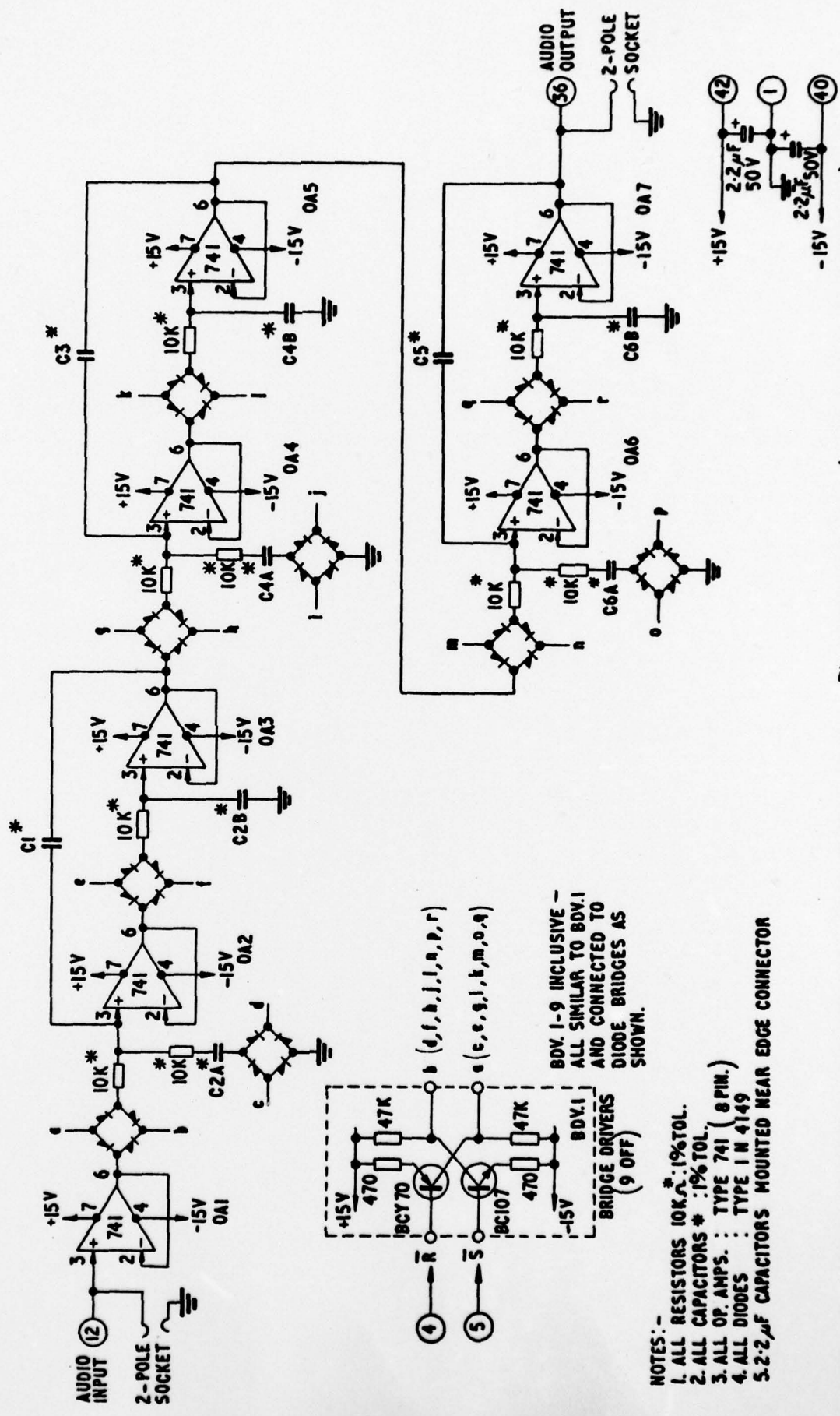

BDV. 1-9 INCLUSIVE -  
ALL SIMILAR TO BDV.1  
AND CONNECTED TO  
DIODE BRIDGES AS  
SHOWN.

- NOTES:-
1. ALL RESISTORS 10K  $\pm$  1% TOL.
  2. ALL CAPACITORS  $\pm$  1% TOL.
  3. ALL OP. AMPS. : TYPE 741 (8 PIN.)
  4. ALL DIODES : TYPE 1N 4149
  5. 2-2  $\mu$ F CAPACITORS MOUNTED NEAR EDGE CONNECTOR

FIG. 10 DYNAMICALLY ADJUSTABLE LOW-PASS ACTIVE 6<sup>TH</sup>-ORDER FILTER (PANEL No.1 - FILTER PANEL)

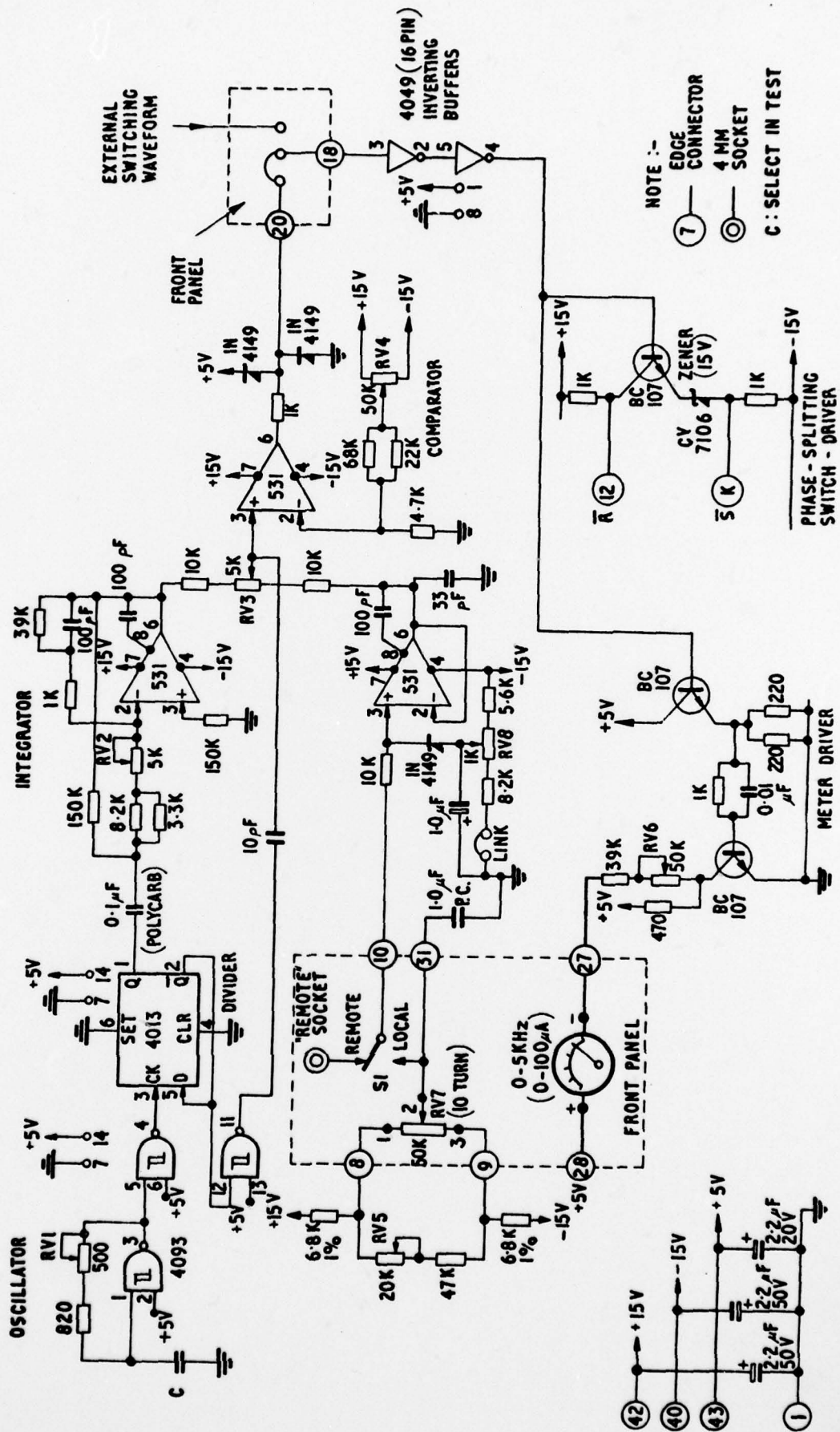

FIG. 11 DYNAMICALLY ADJUSTABLE LOW-PASS ACTIVE 6<sup>TH</sup>-ORDER FILTER (PANEL No.2 - SWITCHING PANEL.)

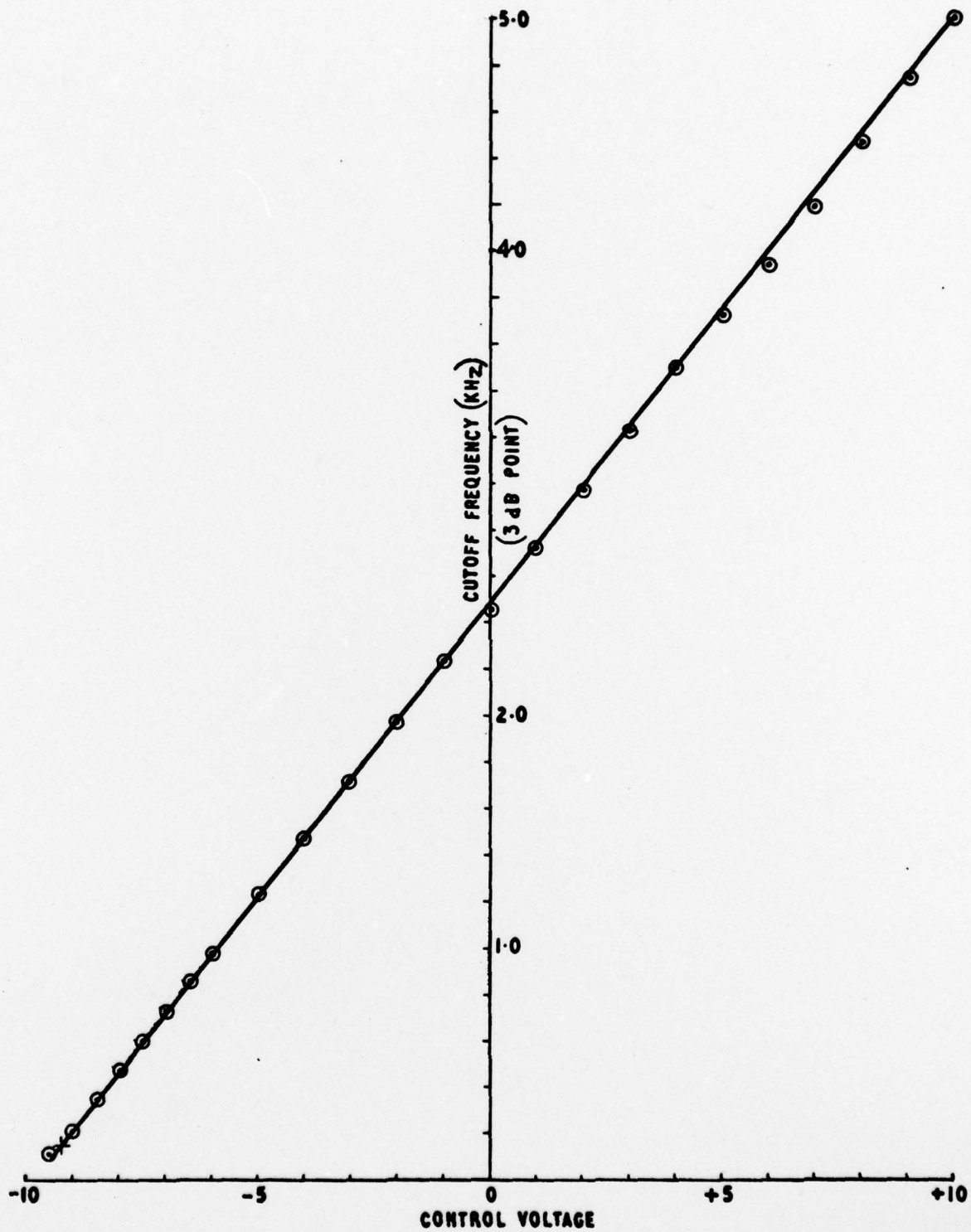

FIG. 12 FILTER CHARACTERISTIC.

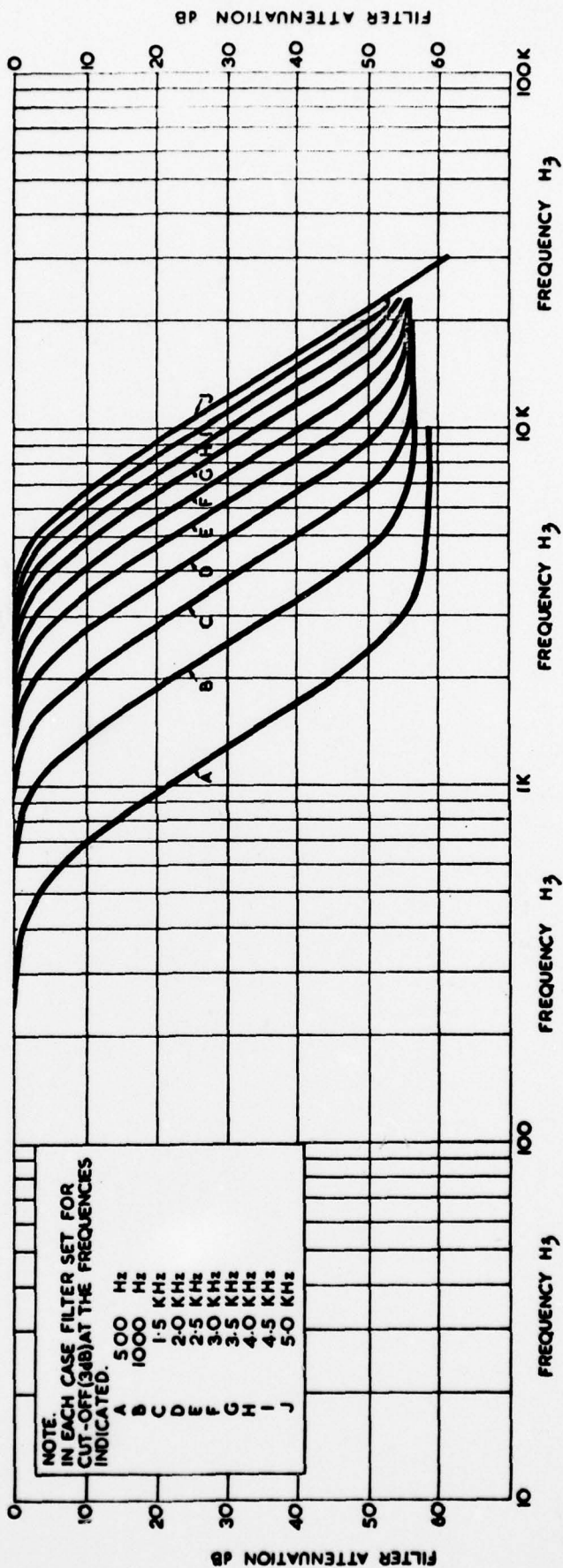

FIG. 13 DYNAMICALLY ADJUSTABLE FILTER. 4<sup>TH</sup> ORDER BUTTERWORTH L.P.

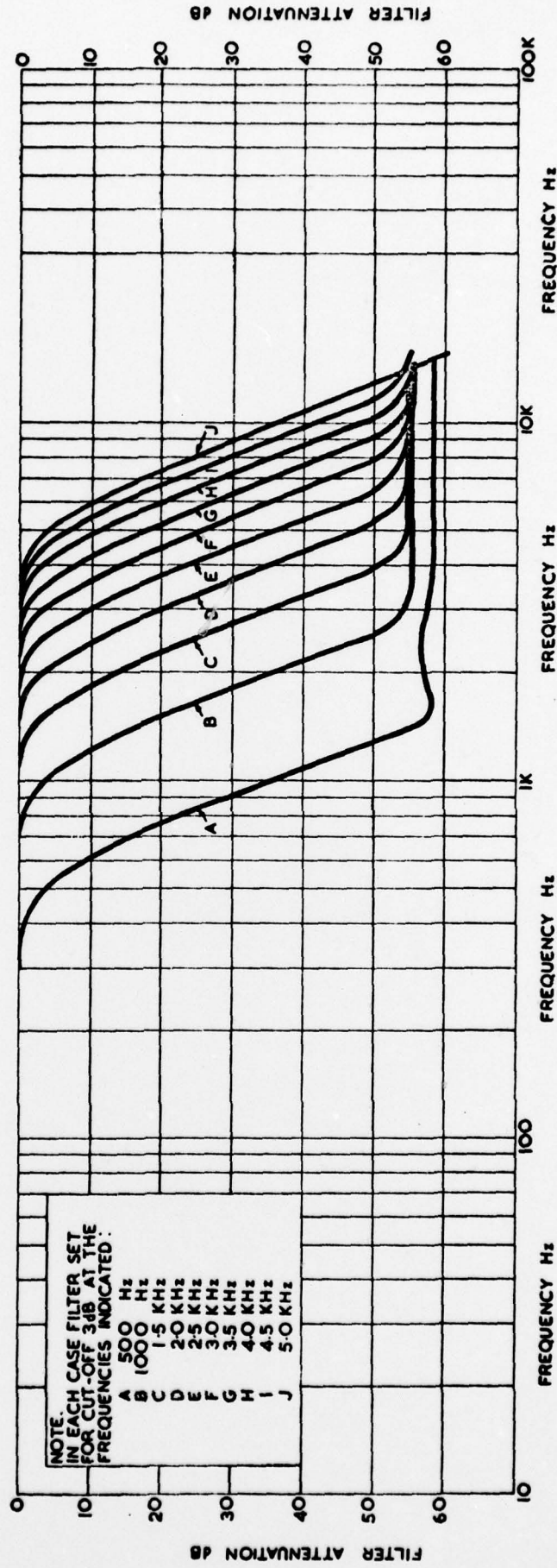

FIG.14 DYNAMICALLY ADJUSTABLE FILTER. 6<sup>TH</sup> ORDER BUTTERWORTH L.P.

MEASURED ON WANDEL & COLTERMAN  
GROUP - DELAY METER.

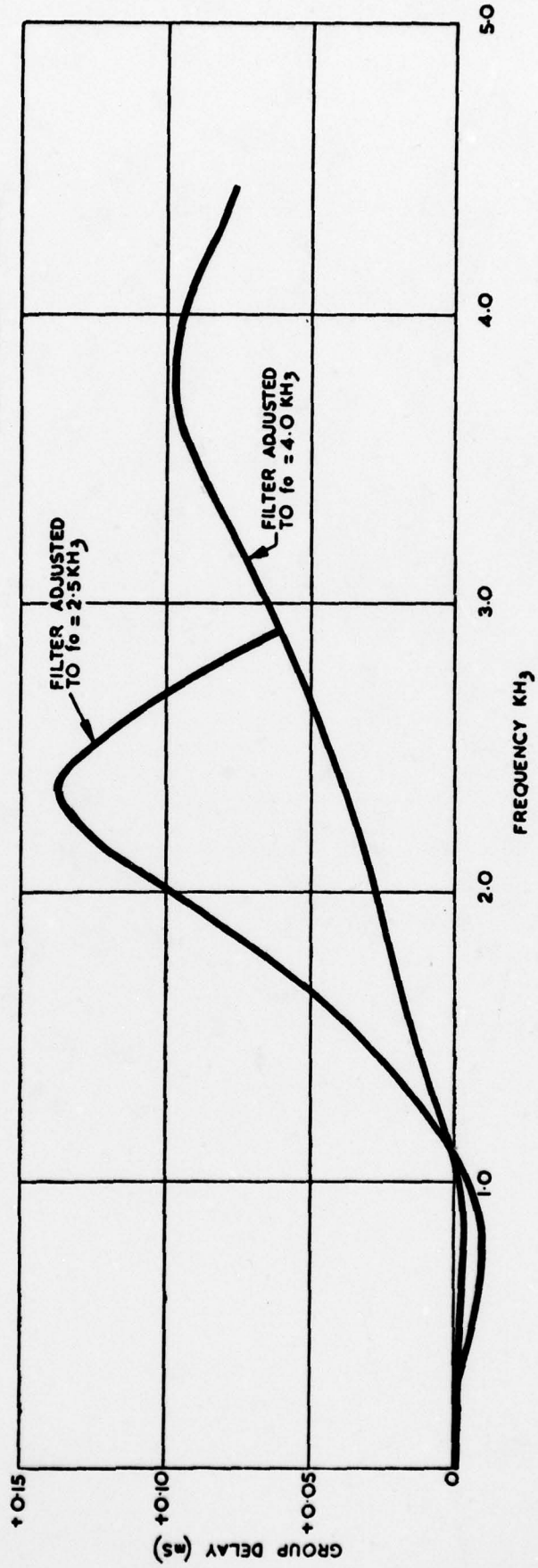

FIG. 15 GROUP - DELAY CHARACTERISTICS. 6<sup>TH</sup> ORDER BUTTERWORTH FILTER.