

AD-A064 147

BDM CORP MCLEAN VA
A PREFERRED CONCEPT FOR T-COR COMMO.(U)

F/G 17/2

MAY 78 R H SCHMIDT, R L ROTHROCK, W E SWEENEY
BDM/W-77-402-TR DNA-4351T-1A

DNA001-76-C-0371

UNCLASSIFIED

NL

| OF |

AD
A064147

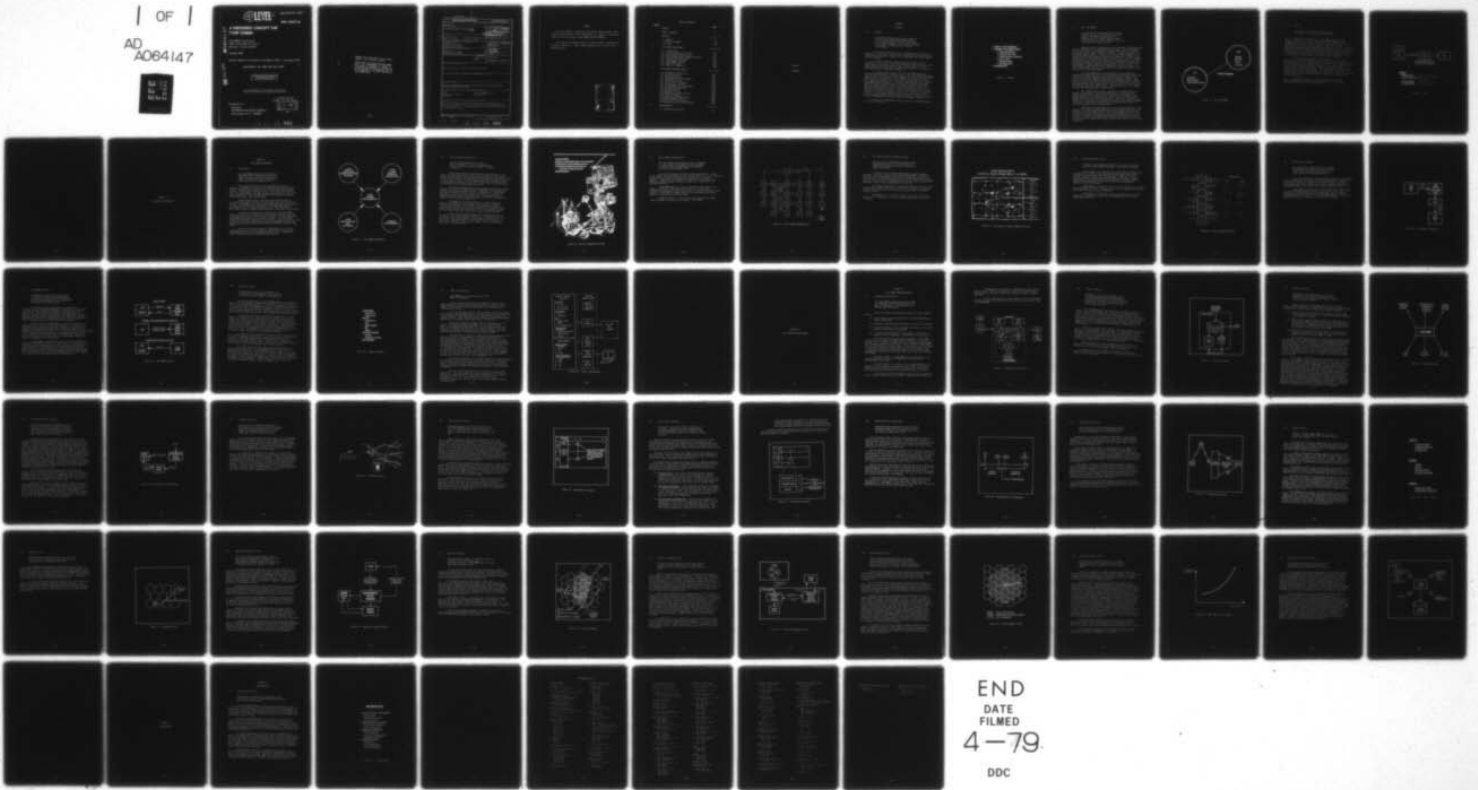

END
DATE
FILMED
4-79
DDC

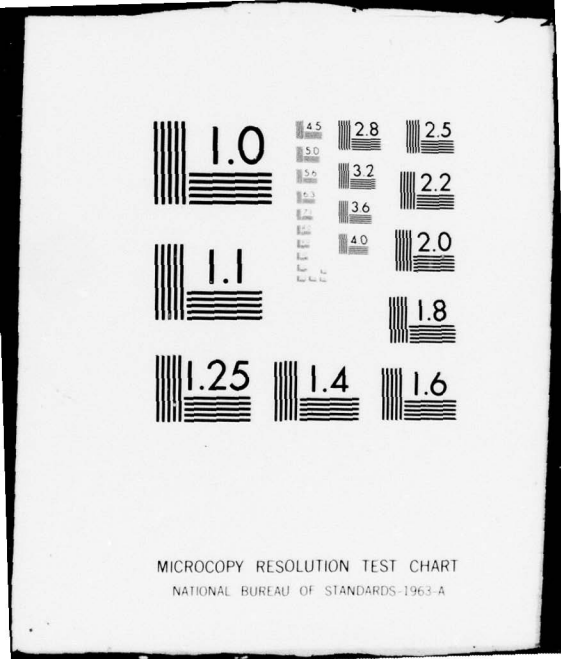

MICROCOPY RESOLUTION TEST CHART
NATIONAL BUREAU OF STANDARDS-1963-A

12 LEVEL II
NW

AD-E300 408

DNA 4351T-1A

ADA 064147

A PREFERRED CONCEPT FOR T-COR COMMO

The BDM Corporation
7915 Jones Branch Drive
McLean, Virginia 22101

15 May 1978

Topical Report for Period for 24 March 1977— 14 August 1977

CONTRACT No. DNA 001-76-C-0371

APPROVED FOR PUBLIC RELEASE;
DISTRIBUTION UNLIMITED.

DDC FILE COPY

THIS WORK SPONSORED BY THE DEFENSE NUCLEAR AGENCY
UNDER RDT&E RMSS CODE B363077464 O99QAXCA10710 H2590D.

Prepared for
Director
DEFENSE NUCLEAR AGENCY
Washington, D. C. 20305

DDC
RECEIVED
FEB 5 1979
B

78 12 14 002

Destroy this report when it is no longer
needed. Do not return to sender.

PLEASE NOTIFY THE DEFENSE NUCLEAR AGENCY,
ATTN: TISI, WASHINGTON, D.C. 20305, IF
YOUR ADDRESS IS INCORRECT, IF YOU WISH TO
BE DELETED FROM THE DISTRIBUTION LIST, OR
IF THE ADDRESSEE IS NO LONGER EMPLOYED BY
YOUR ORGANIZATION.



18 DNA, SBIE

19 4351T-1A, AD-E300 408

UNCLASSIFIED

SECURITY CLASSIFICATION OF THIS PAGE (When Data Entered)

REPORT DOCUMENTATION PAGE		READ INSTRUCTIONS BEFORE COMPLETING FORM
1. REPORT NUMBER DNA 4351T-1A	2. GOVT ACCESSION NO.	3. RECIPIENT'S CATALOG NUMBER
4. TITLE (and Subtitle) A PREFERRED CONCEPT FOR T-COR COMMO	5. TYPE OF REPORT & PERIOD COVERED Topical Report, for Period 24 Mar - 14 Aug 77.	6. PERFORMING ORG. REPORT NUMBER BDM/W-77-402-TR
7. AUTHOR(s) Ralph H. Schmidt, William E. Sweeney, Jr. Ronald L. Rothrock, Patrick H. Riedl	8. PERFORMING ORG. NUMBER(s) DNA 001-76-C-0371 new	10. PROGRAM ELEMENT, PROJECT, TASK AREA & WORK UNIT NUMBERS NWED Subtask 099QAXCA107-10 A107
9. PERFORMING ORGANIZATION NAME AND ADDRESS The BDM Corporation 7915 Jones Branch Drive McLean, Virginia 22101	11. CONTROLLING OFFICE NAME AND ADDRESS Director Defense Nuclear Agency Washington, D.C. 20305	12. REPORT DATE 15 May 78
14. MONITORING AGENCY NAME & ADDRESS (if different from Controlling Office) 10 73p.	13. NUMBER OF PAGES 76	15. SECURITY CLASS (of this report) UNCLASSIFIED
16. DISTRIBUTION STATEMENT (of this Report) Approved for public release; distribution unlimited.		15a. DECLASSIFICATION DOWNGRADING SCHEDULE
17. DISTRIBUTION STATEMENT (of the abstract entered in Block 20, if different from Report)		
18. SUPPLEMENTARY NOTES This work sponsored by the Defense Nuclear Agency under RDT&E RMSS Code B363077464 099QAXCA10710 H2590D.		
19. KEY WORDS (Continue on reverse side if necessary and identify by block number) T-COR Nuclear Weapons Effects Communications Modeling Weapons Effects War Games		
20. ABSTRACT (Continue on reverse side if necessary and identify by block number) This report elucidates a preliminary concept for a T-COR theater combat communications module which, when exercised with other T-COR modules, will provide a capability for improved assessment of the impact of communications on combat effectiveness.		

DD FORM 1 JAN 73 1473 EDITION OF 1 NOV 65 IS OBSOLETE

UNCLASSIFIED

SECURITY CLASSIFICATION OF THIS PAGE (When Data Entered)

391 962

78 12 14 002

PREFACE

This final report is submitted to the Defense Nuclear Agency, ATTN: Captain Frank Eisenbarth, (VLIS), Washington, D.C. 20305, as a deliverable under the terms of contract number DNA001-76-C-0371-P00002.

This report was prepared by Ralph H. Schmidt, Ronald L. Rothrock and William E. Sweeney, Jr., under Program Manager Patrick H. Riedl of The BDM Corporation.

ACCESSION FOR	
NTIS	Video Section <input checked="" type="checkbox"/>
DDC	Unit Section <input type="checkbox"/>
UNANNOUNCED	<input type="checkbox"/>
DISPATCHED	
BY	
DISPATCHED BY UNIT CODES	
DATE	
SPECIAL	
A	

TABLE OF CONTENTS

<u>Chapter</u>	<u>Page</u>
PREFACE	1
TABLE OF CONTENTS	2
1. OVERVIEW	1-1 to 1-7
1.1 Summary	1-2
1.2 Why T-COR COMMO ?	1-4
1.3 Scope	1-6
2. T-COR COMMO REQUIREMENTS	2-1 to 2-19
2.1 Introduction	2-2
2.2 Tactical Communications Types	2-4
2.3 Corps Command Communications	2-6
2.4 Multichannel Systems (Command and Area)	2-8
2.5 Tactical Operations Center	2-10
2.6 T-COR Phase II Messages	2-12
2.7 T-COR COMMO Functions	2-14
2.8 Combat Environment	2-16
2.9 T-COR II Architecture	2-18
3. T-COR COMMO PREFERRED CONCEPT	3-1 to 3-35
3.1 Fundamental Architecture	3-2
3.2 The Service Matrix	3-4
3.3 Request/Directives	3-6
3.4 Environmental Effects Program	3-8
3.5 T-COR Net Structure	3-10
3.6 Service Matrix Structure	3-12
3.7 Service Matrix Elements	3-14
3.8 Message Delays for Record/Data	3-16
3.9 Intermediate Processing	3-18
3.10 Message Integrity	3-20
3.11 Messenger Service	3-22
3.12 Combat Environmental Effects	3-24
3.13 Electronic Warfare	3-26
3.14 Conventional Weapons Effects	3-28
3.15 Nuclear Weapons Effects	3-30
3.16 Additional Levels of Detail	3-32
3.17 Communications Systems Data Base	3-34
4. IMPLEMENTATION	4-1 to 4-3
4.1 Implementation Outline	4-2

CHAPTER I

OVERVIEW

CHAPTER I

OVERVIEW

1.1 Summary

This report provides a preliminary concept for a T-COR theater combat communications module which, when exercised with other T-COR modules, will provide a capability for improved assessment of the impact of communications on combat effectiveness.

The specific objectives of this conceptual design effort are summarized in the figure. The principal study effort was oriented toward defining an architectural framework for a T-COR module to permit communications assessment.

In order to provide a communications assessment tool for incorporation into T-COR, it was first necessary to identify those requirements placed on the communications model by T-COR itself and by the communications systems and processes that must be modeled. Discussion of these requirements is provided in Chapter II.

A series of basic concepts for the T-COR COMMO module were developed and compared with the requirements. For each fundamental approach it was necessary to define the basic interactions between T-COR and T-COR COMMO as well as the response of T-COR COMMO to the combat environment. For the preferred concept it was necessary to address the levels of detail both conceivable and desirable. This allows the development of a basic T-COR COMMO module which preserves the speed of the basic T-COR model. Additional levels of detail allow for increased sophistication of the module as deemed appropriate from initial exercising of the module. In developing the preliminary concept, careful consideration of the software currently in T-COR was necessary to identify any implementation problems inherent in various design approach alternatives and to assist in the selection process and definition of data requirements. Detailed discussion of the T-COR COMMO module preferred concept is provided in Chapter III.

Finally, an implementation plan for the basic T-COR COMMO module is outlined in Chapter IV.

- IDENTIFY T-COR REQUIREMENTS
- DETERMINE T-COR COMMO CONCEPT
 - Fundamental Approach
 - Interactions with T-COR
 - Combat Environment Interactions
 - Levels of Detail
 - Modeling Problems
 - Data Requirements
- IMPLEMENTATION

Figure 1.1. Summary

1.2 Why T-COR COMMO?

The contribution of communications to combat effectiveness can not be determined by direct analysis; therefore representation of communications in a player centered combat simulation such as T-COR is necessary to obtain force multiplier quantification.

Command, Control, Communications and information flow processes are vital to the conduct of military operations; however, actual measurements of the contribution of the processes to combat effectiveness are difficult. An advanced theater combat model called T-COR-II is under development for the Defense Nuclear Agency. T-COR-II will simulate combat dynamics in the Corps area under both nuclear and non-nuclear situations. The design and incorporation of a communications model in T-COR-II will serve as a valuable computational tool in determining the value of communications to the Corps and Division commander as well as quantifying the impact of vulnerabilities and degradation effects induced into the network by nuclear events. The contribution of communications can be determined in terms of measures of effectiveness (MOE) relating to such factors as personnel casualties, equipment attrition, and unit movement.

The T-COR COMMO module discussed herein will be capable of simulating the characteristics of any foreseeable communications system from Corps to the maneuver companies and calculating delays in message flow/information transfer caused by communications handling procedures, transmission, hostile countermeasures, and other environmental effects. These delays will affect the time of receipt of operations orders and internally generated messages thus influencing artillery targeting, unit reinforcement, unit movement and other combat factors. The end result will be to impact the above mentioned measures of effectiveness.

The communications networks simulated by the COMMO module will transmit messages after a delay time commensurate with the available communications capability and the level of jamming or firepower attacks against elements of the communications system. Alternate routings and message expiration times are also considered. Each of the communications nodes within a network can be attacked and sustain varying levels of damage. In addition, communications status can be extracted from the module to serve as a decision aid in the T-COR model.

Development of T-COR COMMO will provide a valuable measure of the impact of loss and/or degraded communications on tactical combat that is not available in current communications models such as ETC³ (European Theater Command, Control and Communications). Hence T-COR COMMO will serve as the critical link between the detailed communications degradation analysis conducted in the INCA (Integrated Nuclear Communications Assessment) program using ETC³ and the combat effectiveness measures which result from the T-COR simulation.

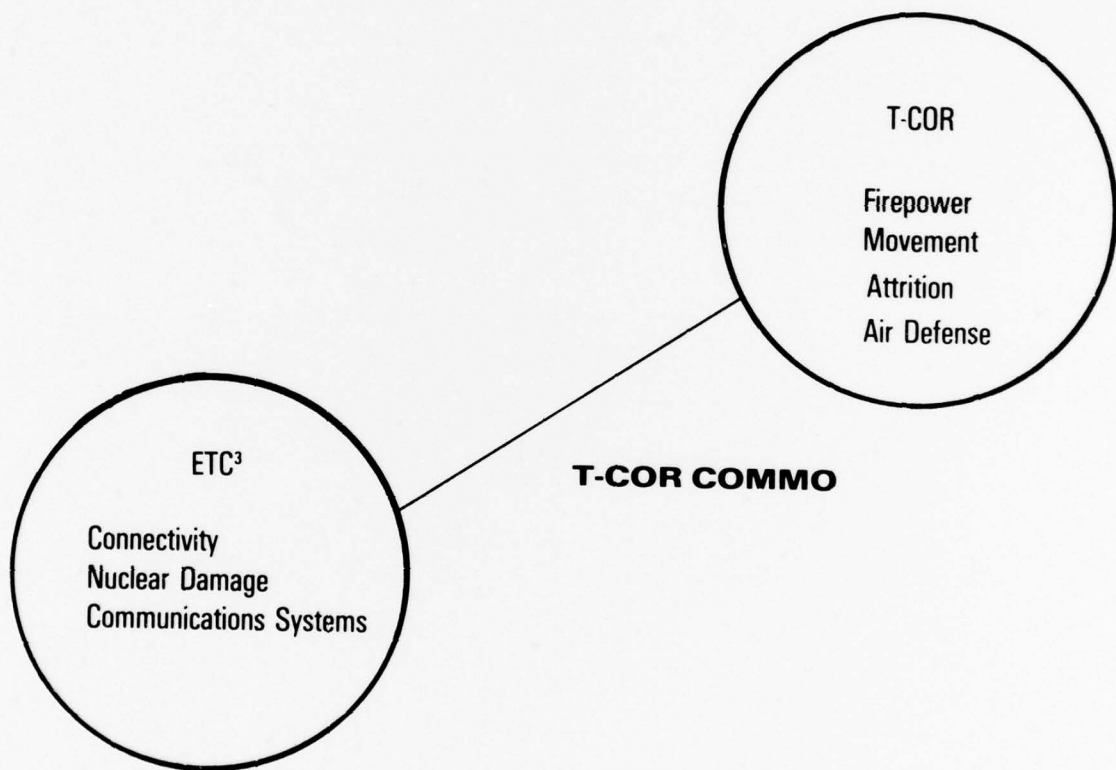

Figure 1.2. Why T-COR COMMO ?

1.3 Scope

The scope of the T-COR communications module is bounded by the characteristics of T-COR.

The general relationship of T-COR COMMO with other T-COR elements is shown in the figure. Essentially, T-COR COMMO accepts messages generated by C² nodes and delivers them to the addressee after an appropriate time delay. The time delay is affected by system perturbations due to the combat environment. Thus the scope of the analyses that can be conducted using T-COR COMMO are bounded by the level of detail contained within the T-COR C² node and combat modules utilized. For example, the impact of the loss of communications to an engineer support element can not be evaluated if that element is not explicitly represented in T-COR, no matter what level of detail is contained within T-COR COMMO.

The scope of the conceptual T-COR COMMO module is also shown in the figure. This module considers players from Corps to line company echelons, and their associated communications systems. The messages generated by the C² modules are of variable description (i.e., they may specify any or all of the following attributes: address, precedence, length, classification, transmission system). The combat environments represented include nuclear, EW, and conventional. All three primary types of communications used at Corps and below are represented. Radio communications include satellite links and multi-channel terrestrial links as well as single channel nets.

Although not explicitly stated, the model can represent communications between Air Force units located in the Corps area of operations and between Army and Air Force units.

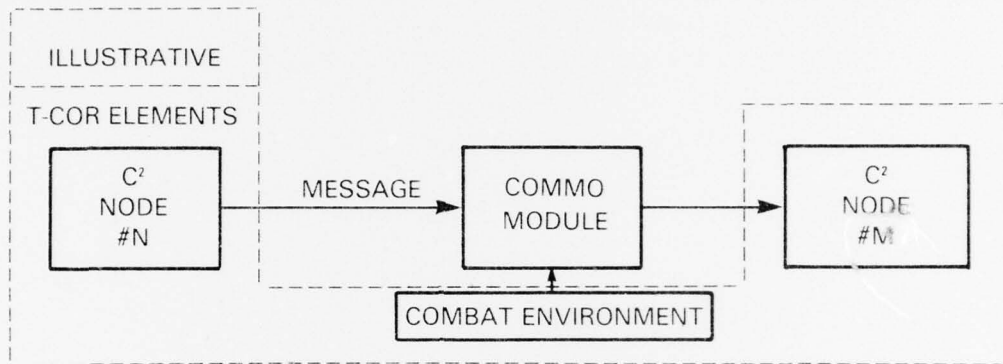

SCOPE

- COMMAND ECHELON: Corps → Line Company
- MESSAGE CHARACTERISTICS: Variable, function of level of detail of C² node representation
- COMBAT ENVIRONMENT: Nuclear, EW, and Conventional
- TYPE COMMUNICATIONS: Radio, Wire, Messenger

Figure 1.3. Scope

CHAPTER II
T-COR COMMO REQUIREMENTS

CHAPTER II

T-COR COMMO REQUIREMENTS

2.1 Introduction

The T-COR COMMO module must be responsive to the communications systems which are found at CORPS and below, the C² functions played in T-COR, the combat environment, and the basic T-COR architecture and computer coding.

The fundamental concept for the T-COR COMMO module must be designed to accommodate a broad spectrum of communications capabilities and systems. The basic types of systems will vary from single user dedicated circuits to multichannel, multiuser systems. Transmission media include radio, wire and messenger. The types of messages include voice, data, hard copy, and graphics. The T-COR COMMO concept is fully capable of handling all of these systems, media, and messages.

T-COR generates specific information requirements related to the issuance and receipt of high priority messages which effect the play of the game. T-COR COMMO must provide a rapid technique that efficiently supports the main game played by T-COR. Additionally, the T-COR COMMO module will be developed so as to enhance the capabilities of T-COR by providing a more realistic impact of communications processes on the conduct of the battle.

In addition to improving the T-COR main game, the T-COR COMMO module will provide initial answers to the important question of the impact of communications losses on the conduct of the battle. To achieve this goal, T-COR COMMO must be sensitive to the combat situation. The T-COR COMMO concept includes direct interaction with the nuclear, EW, and conventional combat environments. Specific combat events will cause T-COR COMMO to assess the impact on communications capabilities and provide the data to the main T-COR routine.

Finally, the efficient design of T-COR COMMO requires that the module be structured to fit into the basic T-COR software. In particular, T-COR COMMO will access the T-COR Automated Data Base for information and be fully integrated into the Simulation Control Software.

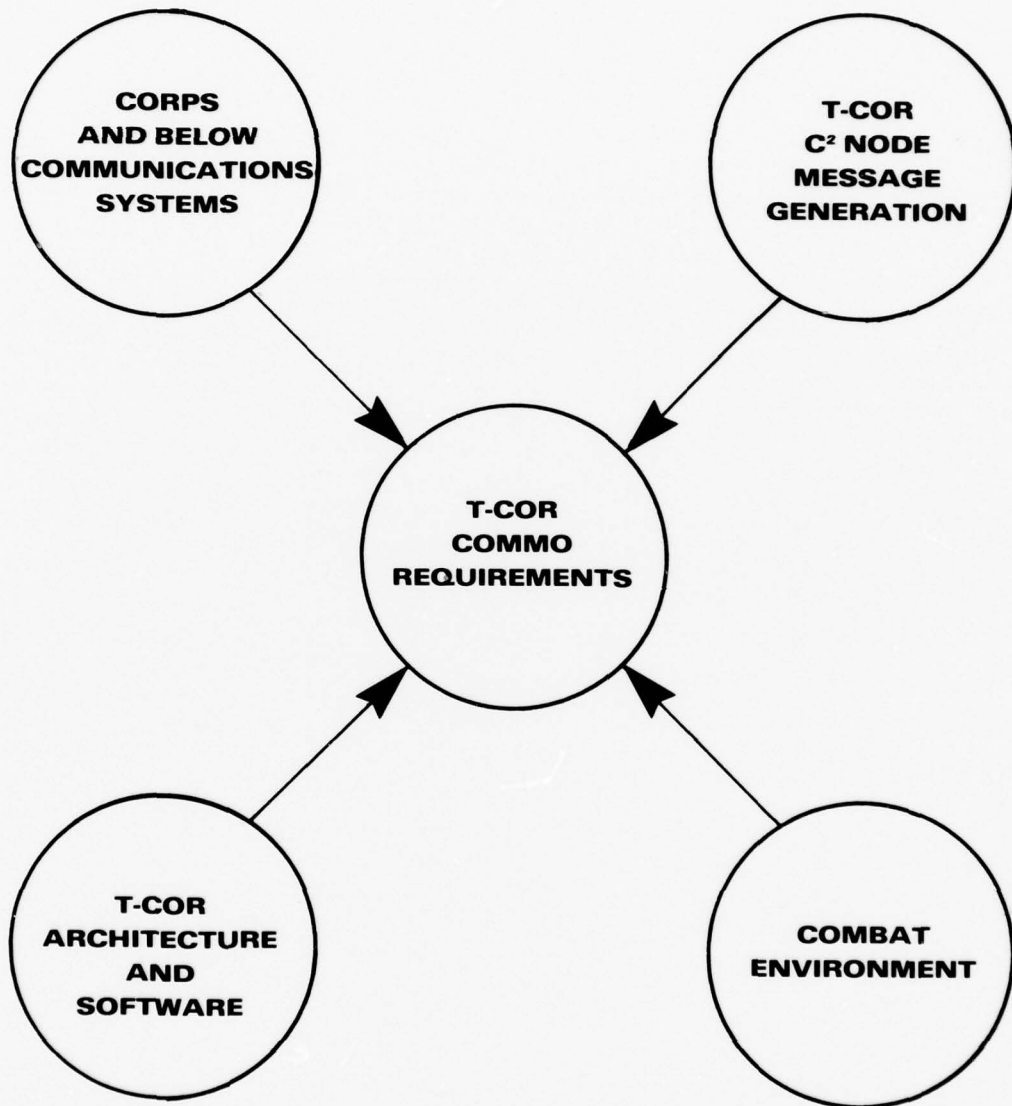

Figure 2.1. T-COR COMMO Requirements

2.2 Tactical Communications Types

Tactical communications from the Corps to the line companies is diverse in communications systems, transmission media, and types of messages transmitted.

The principal means of communications at Corps and below is via radio. The major radio systems include single channel voice nets, single channel radioteletype nets and both low and medium capacity multichannel systems. The multichannel systems carry both sole user and common user voice circuits as well as data circuits. The T-COR COMMO module must be designed to model the communications processes over systems as widely diverse as single channel radioteletype and multichannel common user voice.

The transmission media used at Corps and below for the radio systems include LOS microwave, tropospheric scatter, satellite, HF (groundwave and skywave), VHF FM and UHF AM (Air-Ground). T-COR COMMO will include combat environment interaction routines that will be sensitive to the type of equipment and type of transmission media used. The nuclear effects and electronic warfare effects routines must provide information to T-COR which accounts for the transmission media used.

T-COR COMMO must also have the ability to model information transfer for messages of varying lengths with a variety of different preparation and handling. For instance, the time delay associated with voice messages may consist only of the time necessary to establish a voice link connection whereas the preparation time for a radioteletype message may play a significant role in the overall message transmission time.

Finally, Corps and below communications includes an overlay of both special and scheduled messenger capability. This capability can play a significant roll in the transfer of long messages and map related information. Messenger capability includes motor, air, and foot delivery and is highly dependent on enemy action, weather, terrain, and physical locations of the involved units.

**RADIO/WIRE
SINGLE CHANNEL/MULTICHANNEL
VOICE/DATA/FACSIMILE/RATT
LOS/GROUNDWAVE/TROPO/
SATELLITE/SKYWAVE
MESSENGER**

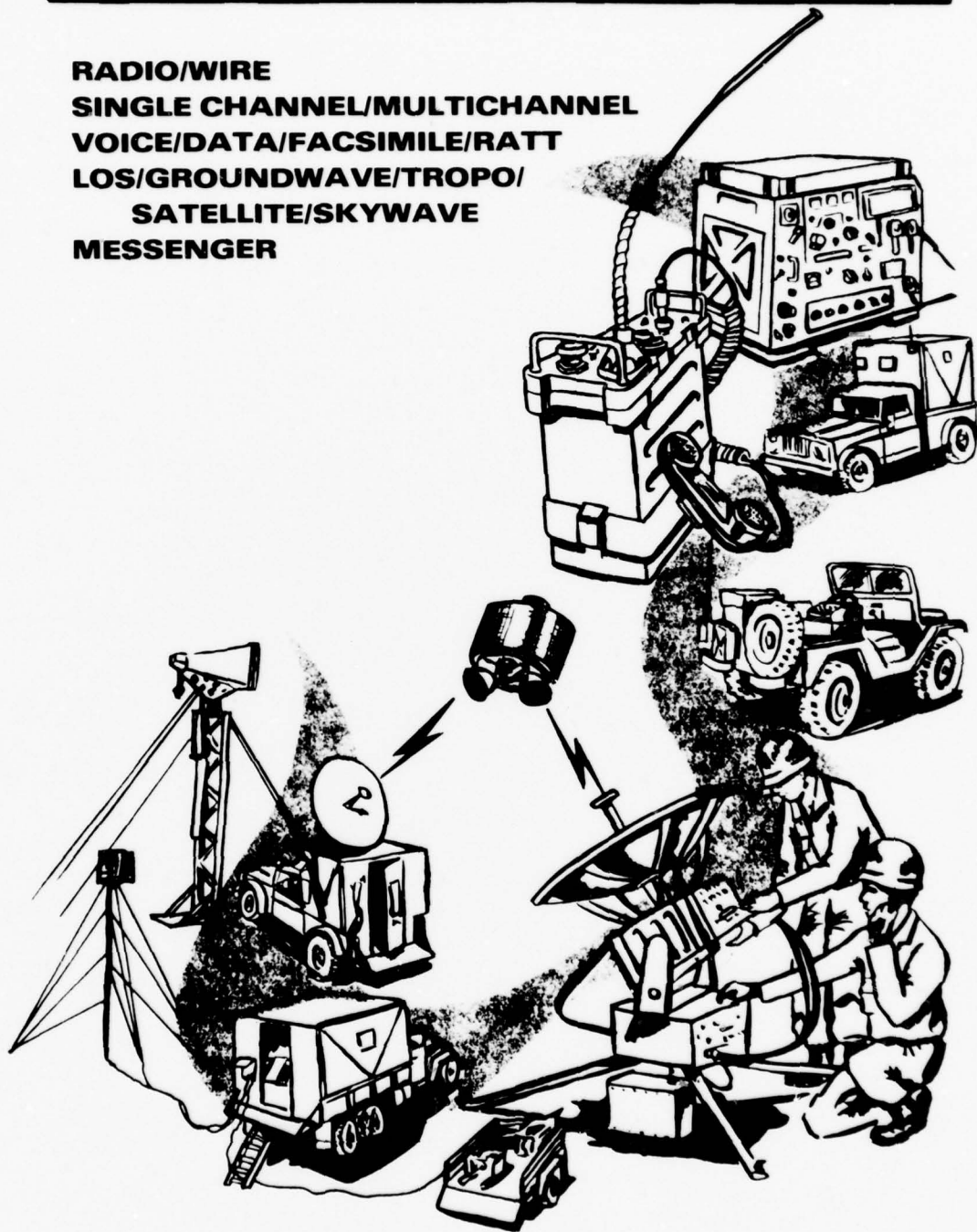

Figure 2.2. Tactical Communications Types

2.3 Corps Command Communications

The Corps command communications system is composed of a broad spectrum of capabilities and equipments in order to meet the communications requirements from Corps to the maneuver units.

A typical distribution of Corps command communications is shown in the figure. As one proceeds from Corps to the maneuver units, the available communications connectivities become less redundant with much lower capacity. Single channel FM capability is observed to be present at all echelons of command whereas multichannel capability is observed only at the higher echelons.

T-COR COMMO models all of the communication means shown in the figure to at least a first-order level of detail. The inclusion of messenger-type communication (physical delivery by aircraft, vehicle or foot soldier) in T-COR COMMO is deemed necessary for completeness and logical because of interplay with electronic means.

Though not explicit in this figure, both voice and record data systems throughout the Corps can be played in T-COR COMMO.

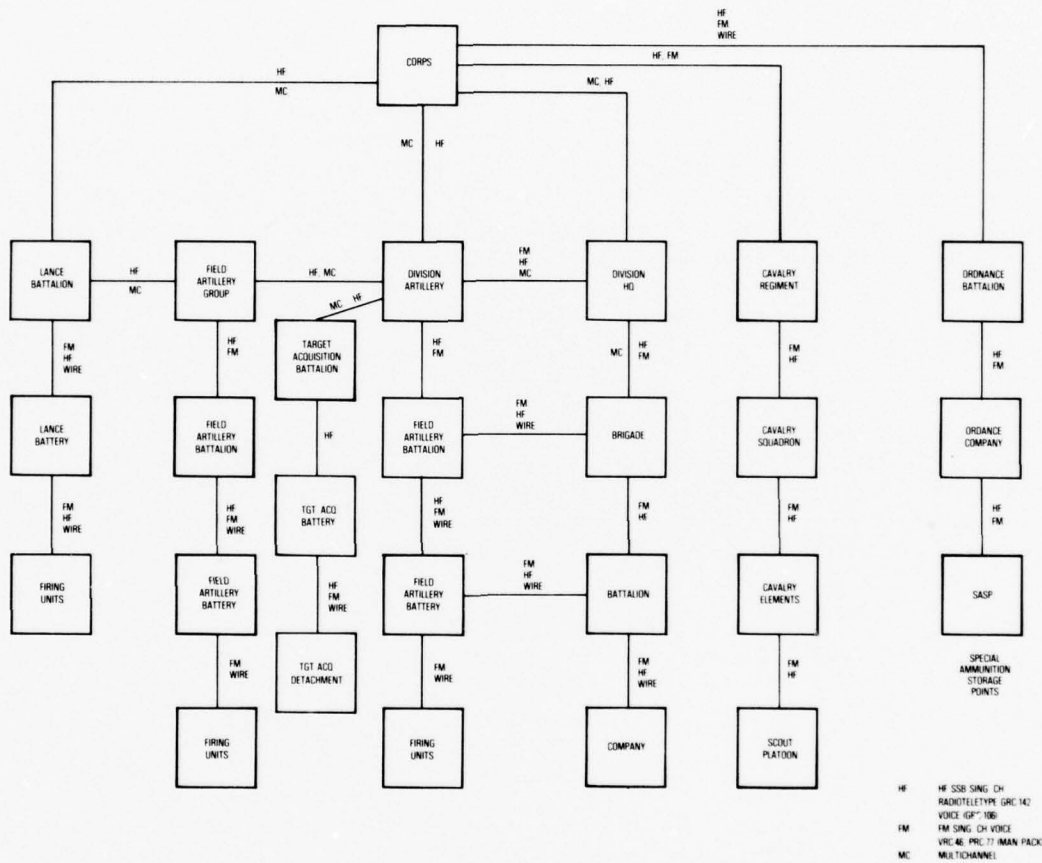

Figure 2.3. Corps Command Communications

2.4 Multichannel Systems (Command and Area)

Corps and Division Multichannel systems provide command and control links and additional area communications capability which is available for command utilization.

In addition to the command communications systems discussed previously, there are extensive multichannel communications capabilities available in both the command and area systems established in the Corps/Division area. Although established primarily to service administrative and logistics traffic as well as attached units, the Corps area system provides additional capability for command/control utilization.

A stylized configuration of the command multichannel (light lines) and Corps area systems (dark lines) is shown in the figure. Interneting provides the capability of utilizing the Corps area system for command/control traffic.

T-COR COMMO will be designed to model the current multichannel systems, and via expansion of the basic approach, additional systems such as TRITAC.

TYPE DEPLOYMENT TACTICAL FIELD RADIO RELAY SYSTEMS

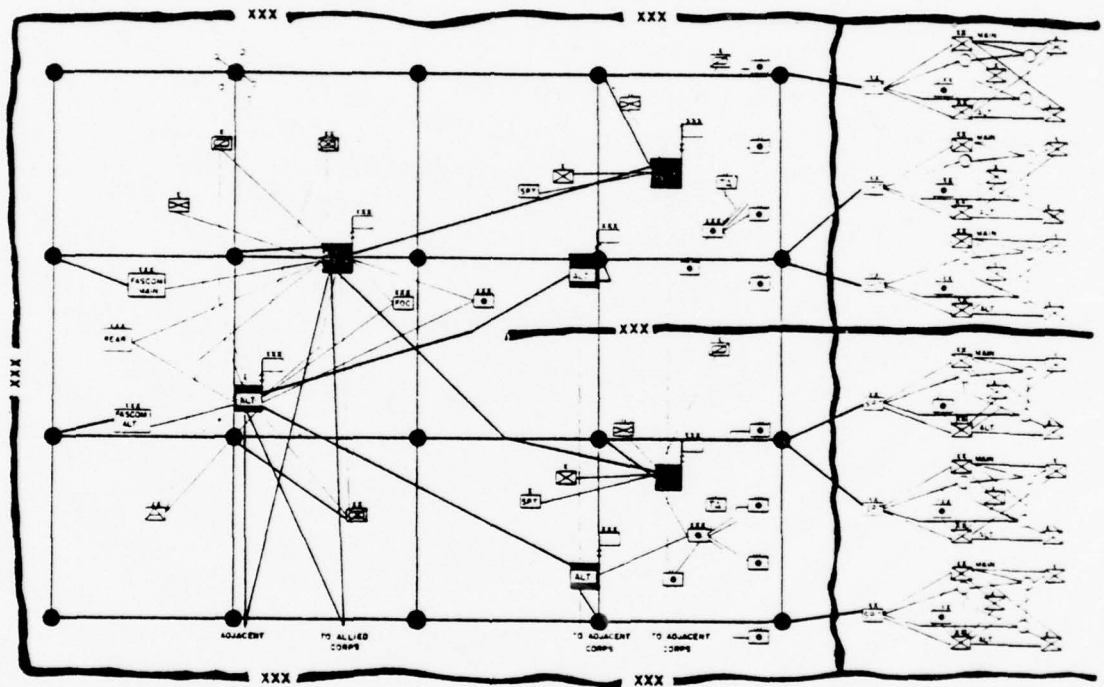

Figure 2.4. Multichannel Systems (Command and Area)

2.5 Tactical Operations Center

A typical tactical operations center, e.g. a division tactical operations center (DTCO), generates a high volume of messages.

Typical elements of a DTCO and their communications connectivities are shown in the figure. A high volume of message traffic flows within the DTCO and to both higher and lower echelons. In addition to voice traffic, substantial quantities of record traffic, data, maps, overlays, photographs, etc is transmitted within and external to the TOC. Similar functions are performed at a Corps TOC and within the command/staff elements at Division and below.

T-COR COMMO will not model in detail the full operation of a tactical operations center but rather will address the critical messages and functions which impact on the play of the T-COR model.

T-COR COMMO will reflect the internal communications of a TOC by impacting on the quality and timeliness of messages that are received or transmitted by the TOC.

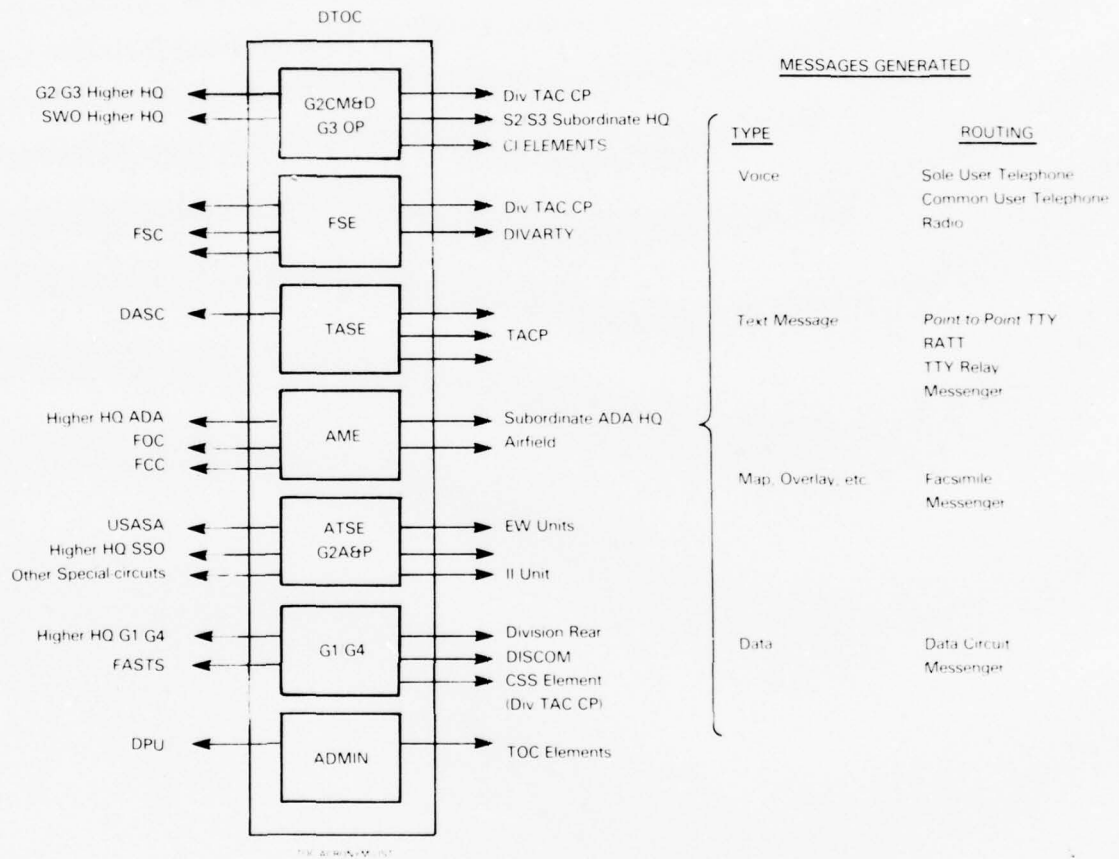

Figure 2.5. Tactical Operations Center

2.6 T-COR Phase II Messages

The T-COR Phase II command and control modules aggregate all TOC elements into one entity and limit message generation to operations orders, status reports and intelligence reports.

Within the T-COR model, tactical operations centers are considered to be a single entity with respect to location and function. Interaction with other C^2 elements is restricted to critical messages which have significant impact on the conduct of the battle. These critical messages include operations orders, status reports, and intelligence reports.

T-COR COMMO will account for the additional traffic that is known to exist within and between C^3 nodes but will not explicitly model the information transfer associated with the background traffic. However the background traffic, implicit in the T-COR COMMO model, will effect the handling, routing, and transmission of the critical messages.

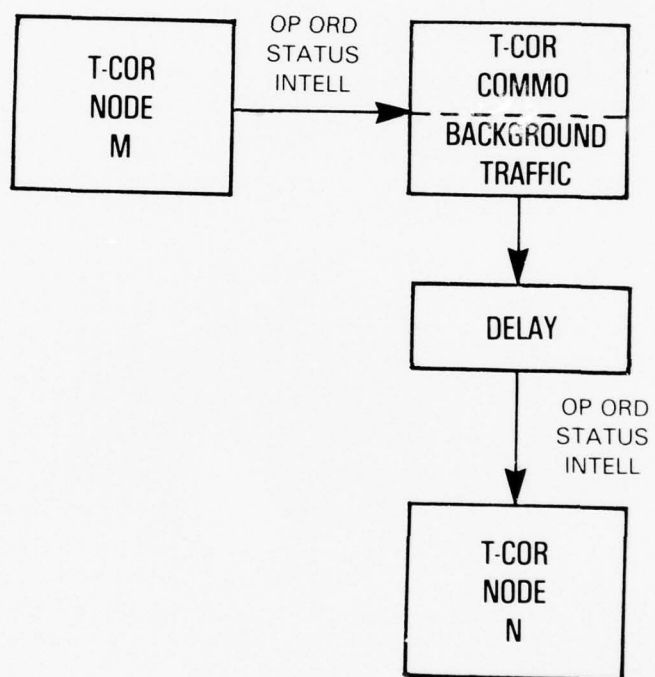

Figure 2.6. T-COR Phase II Messages

2.7 T-COR COMMO Functions

T-COR COMMO will support the efficient play of T-COR, provide communications degradation information to impact the course of the battle, and provide communications status information for automatic or interactive play.

At the broad conceptual level there are three primary interactions between T-COR and T-COR COMMO. During the play of the T-COR main game, critical messages are generated at C² nodes for delivery to other C² nodes. Upon receipt of instructions that T-COR desires to transmit a message from one node to another, T-COR COMMO determines the availability of the primary or alternate delivery capabilities, determines the delay associated with the message and provides that information to T-COR. T-COR then continues with the play of the main game.

A second function of T-COR COMMO is to quantify the effects on communications of a variety of combat related events. For simplicity only enemy and friendly action have been shown, although this interaction is capable of addressing other environmental or operational effects such as weather and increased traffic levels. In this type of interaction T-COR provides to T-COR COMMO specific information relating to the conduct of the battle (e.g., a series of nuclear detonations). T-COR COMMO then assesses the impact of these battle actions and modifies, as appropriate, message time delays for subsequent use in the main game.

The third type of interaction is the provision of communications status from T-COR COMMO to T-COR. This interaction is the equivalent of a commander asking his communications officer to report on the communications status with respect to the capability to interact with subordinate and higher commands. The status as reported by T-COR COMMO (the communications officer) can then be used by T-COR (the commander) as a basis for decisions. Within T-COR the decision process can be made automatically by the software or via the man-in-the-loop when operating T-COR interactivity.

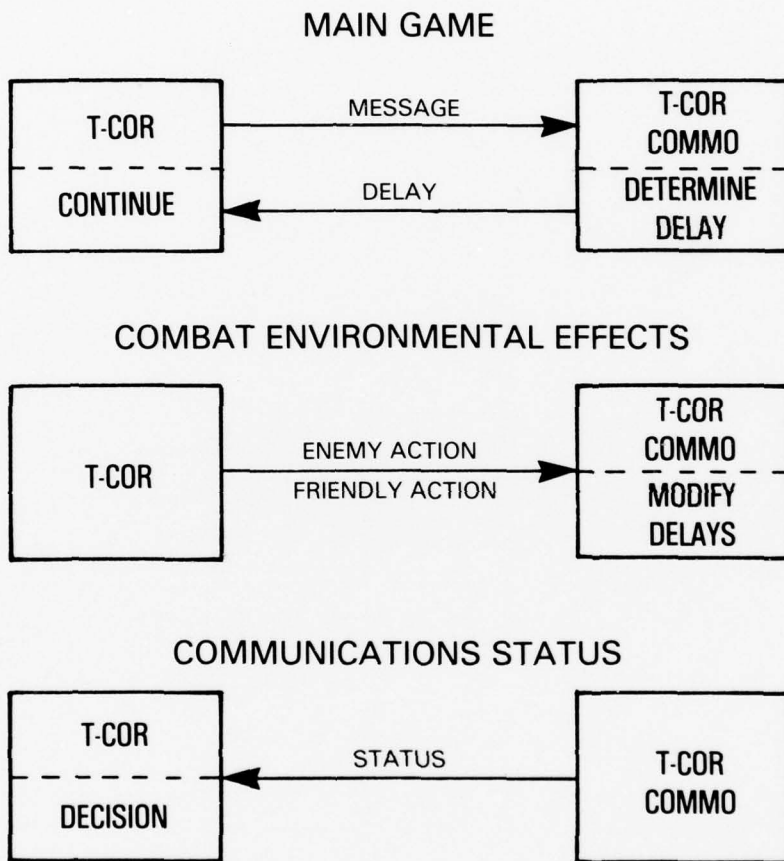

Figure 2.7. T-COR COMMO Functions

2.8 Combat Environment

A major design feature of T-COR COMMO is the incorporation of a methodology for representing the impact of combat dynamics on communications.

A principal objective of the T-COR COMMO module is to provide the tool by which the impact of communications capability can be measured in terms of force combat effectiveness. In order to accomplish this objective, it is necessary that T-COR COMMO model the status of communications as a function of the state of the battle as modeled in T-COR. This will require not only close interaction with the T-COR main game but also special routines which translate T-COR combat actions into communications gains and losses.

The nature of the combat environment representations in T-COR COMMO will be determined to a large extent by the combat representations in T-COR. The location of communications nodes is governed in part by the hexagonal grid coordinate system employed in T-COR. The minimum hex size for the Corps area model is 1.35 km (center-to-center). Hence C^3 elements will be located within this grid system. T-COR allocates conventional weapons on an area basis and calculates damage as a percentage loss to all units in the area. T-COR COMMO will translate conventional losses as provided by T-COR into changes in communications capability.

For nuclear bursts, T-COR will provide a hex grid identification, and required weapon burst parameters such as yield, height of burst, time of burst. T-COR COMMO combat effects subroutines will convert this information into communications losses. The basic data to support the nuclear combat effects subroutines will be derived from the detailed results of the tactical assessments conducted under the INCA program.

Electronic warfare can also cause significant degradations in communications capability. The T-COR COMMO module will also include jamming subroutines as part of the combat environments capability. Finally, the movement of combat units impacts not only on their combat effectiveness but also on their communications capability. Hence, data on unit movement provided by T-COR can be used to update communications status to reflect loss of capability during movement. Further discussion of the concepts for the combat environment modules is found in Chapter III.

CONVENTIONAL
Equipment Loss
Personnel Loss
NUCLEAR
Personnel Loss
Blast
Nuclear Radiation
EMP
Blackout
ELECTRONIC WARFARE
Jamming
Destruction of Jammers
UNIT MOVEMENT

Figure 2.8. Combat Environment

2.9 T-COR II Architecture

T-COR COMMO must fit within the basic T-COR Phase II architecture.

The key architectural features of T-COR* which influence T-COR COMMO design are the use of a common simulation control structure, process modules without hard coded data, a user oriented input language, and a flexible data structure.

Input is achieved by means of a user oriented input language (UOIL) using subject, verb and object phrases. The Red and Blue sides are identified by an introduction line followed by the unit identification, location and command structure. Other input data such as terrain and communication network descriptions, for example, would be described in similar form.

The Scenario Selection Processor (SSP) is the interface for the user to initialize the execution of T-COR. The user identifies the data in the Automated Data Base (ADB) that is to be used and specifies any additions or modifications required for the specific scenario. The Input Processor (IP) locates the appropriate data, merges the ADB and SSP Information and creates the initial Simulation Data Structure (SDS).

The input data is stored in a dynamically-allocated data space which grows, shrinks and is reused depending on the actual requirements for space during input or execution. This is accomplished by use of list processing techniques and eliminates the requirement to edit and change modules when additional data types are required. The major data elements include the scoreboard perceptions, communications net characteristics, and event lists. The scoreboard contains all of the real attributes of each unit that are in the simulation. The perceptions list contains the data that a unit uses to understand its battle conditions. The Discrete Event List (DEL) contains all of the currently scheduled events that are to occur at a future instant in time. The Continuous Event List (CEL) contains all of the currently scheduled events that are to occur during a period of time.

The number and complexity of the process modules vary widely depending on the degree of detail required and the scope of the simulation. There are sets of modules that differ by combat unit size and function. In addition, there are alternative modules that provide for decisions by employing man-in-the-loop techniques as opposed to being totally automated, if this capability is desired.

The time at which each event occurs may be stored for post simulation query. This query is done using a post processor which provides the capability to trace the impact on unit status of each event to its source. In addition, combat reports are produced by the Report Processor.

*For more information on T-COR see, "The T-COR II-A Model" BDM/W-77-427-TR, 9 November 1977.

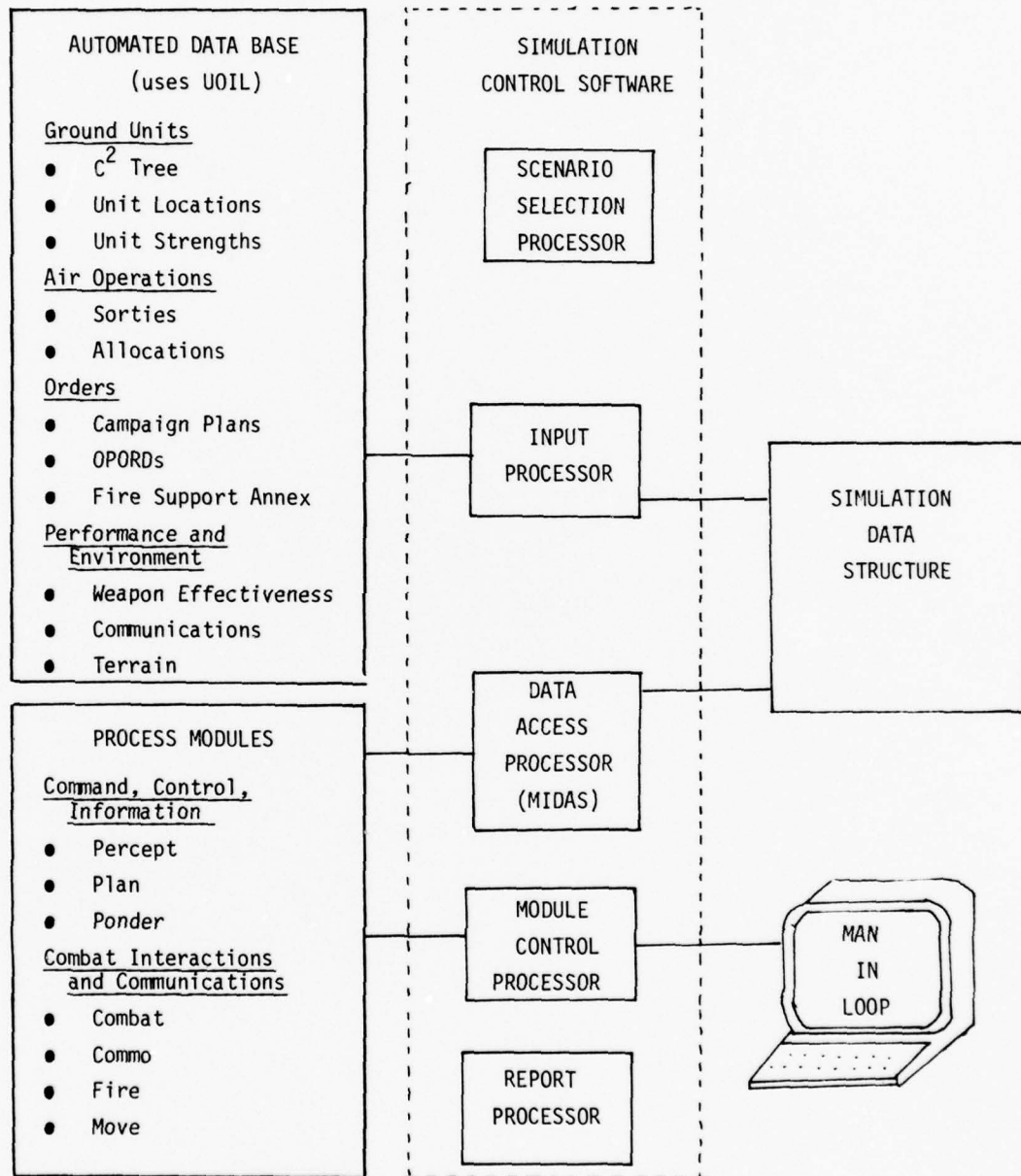

Figure 2.9. T-COR II Architecture

CHAPTER III
T-COR COMMO PREFERRED CONCEPT

CHAPTER III

T-COR COMMO PREFERRED CONCEPT

3.1 Fundamental Architecture

The T-COR COMMO preferred design concept and its fundamental architecture embodies a high degree of modularity in conjunction with a top-down modeling approach.

There are several key advantages associated with the foregoing such as:

- (1) The development and implementation of the T-COR COMMO model is greatly facilitated.
- (2) Subsequent code enhancement/modification is easier to implement.
- (3) Execution efficiency can be increased, particularly when varying levels of model detail are employed.
- (4) A large degree of flexibility is provided in virtually all aspects of model development, implementation and utilization.

The figure presents the high-level structure of T-COR COMMO in addition to its major functional processing modules. The totality of elements within the dashed rectangle comprises the COMMO simulation model which executes concurrently with T-COR. A basic premise of T-COR COMMO is that the communications simulation model is not an end in itself but rather is completely responsive and consistent with the requirements of T-COR. To achieve this objective, T-COR "communicates" with the COMMO module through T-COR's System Control Software (SCS) which controls and executes T-COR COMMO.

The basic elements of T-COR COMMO are the Service Matrix, the Environmental Effects Program, the COMMO Status File and special calculations and subroutines.

The Service Matrix is the heart of the T-COR COMMO module and contains the basic communications data for use by T-COR. The Service Matrix also provides access to special calculations and subroutines to generate message processing data not contained directly in the matrix.

The Environmental Effects Program contains all the subroutines which translate combat actions into changes in communications capability.

The COMMO Status File maintains communications status summary data for use by T-COR in the selection of alternative communications handling and to aid either T-COR or the interactive players in making decisions.

Finally T-COR contains critical elements such as the Automated Data Base and the Simulation Data Structure which provide data for input into T-COR COMMO.

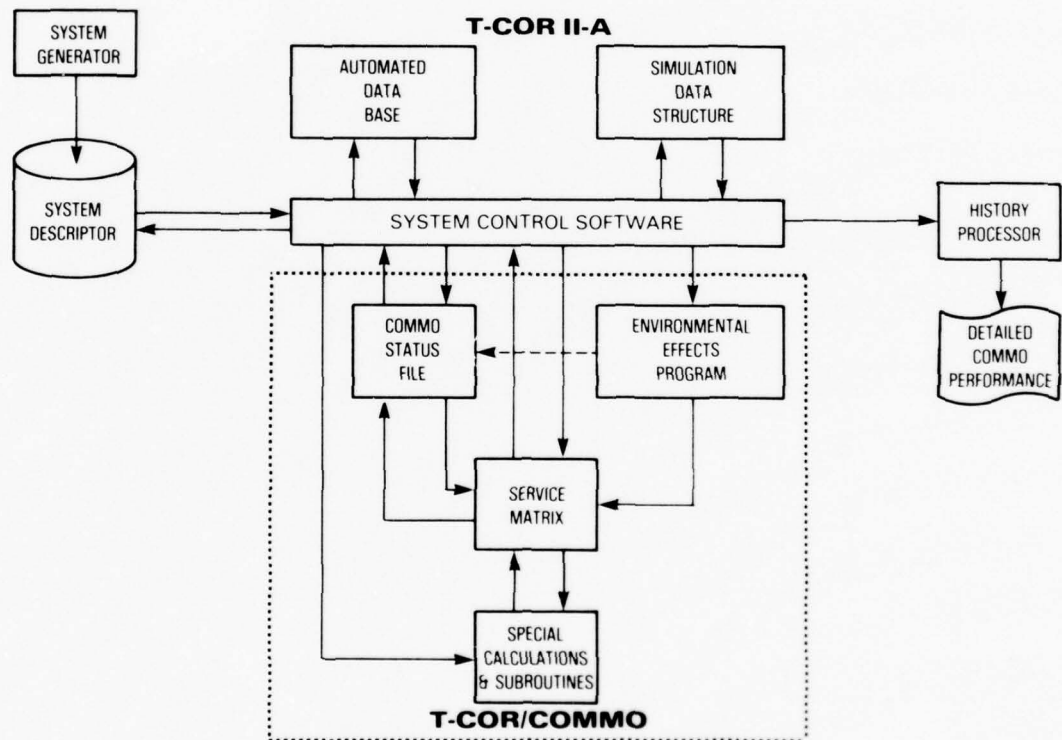

Figure 3.1. Fundamental Architecture

3.2 The Service Matrix

The heart of the preferred approach to the T-COR COMMO module can be conceptualized as a three dimensional matrix with communications processing time entries with subscripts for the sending mode, the transmission system used, and the receiving mode.

This conceptual matrix is referred to as the Service Matrix. In general, when the T-COR COMMO model is exercised by T-COR the desired result is total communications processing delay time between a specific pair of nodes or users. In many cases, this number may reside in the Service Matrix and a direct result can be returned to T-COR quickly and efficiently. As the combat situation changes such that this particular communications path (or any other for that matter) is affected, another module of T-COR COMMO assures that the appropriate modification(s) is applied to the Service Matrix.

There will be other cases, however, where the communications service delay time must be computed. In these cases, the Service Matrix provides addresses of the appropriate subroutine codes to calculate those times. An example of the use of subroutines would be the requirement to process a message through an interswitched network, should such networks become available in the Corps area. For a given message transmission a combination of direct and computed delay is not an unusual situation.

The Service Matrix is only conceptually a matrix because in practice the information will be highly compressed into a set of lists and pointers so as to minimize computer memory space demands.

Summarizing, the Service Matrix is the single processor of communications traffic and is designed to minimize computer simulation time required to service messages.

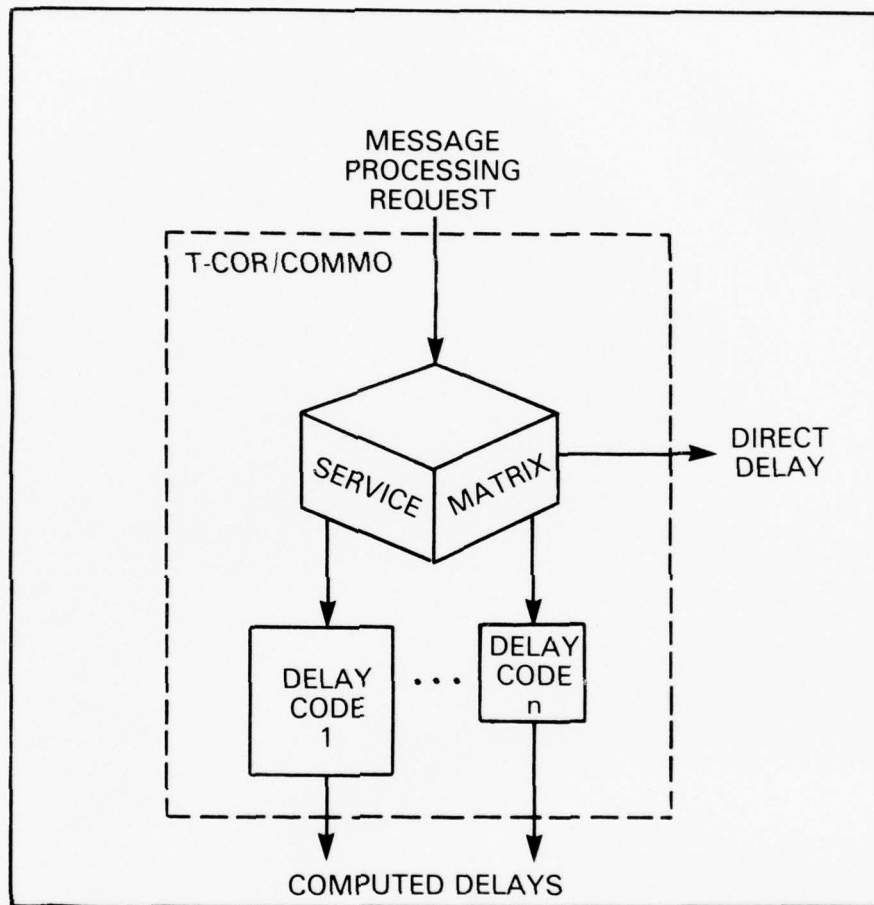

Figure 3.2. The Service Matrix

3.3 Request/Directives

The range of T-COR instructions to the T-COR COMMO module varies between a completely defined request to a very loosely defined request in steps as fine as detail requires.

T-COR exercises the T-COR COMMO module through a Request/Directive (R/D) command which is coordinated by the system control software and which falls into one of the following three generic categories.

- (1) Communications Service Request (CSR) indicates to T-COR COMMO that communications processing is required and expects disposition of that request as output.
- (2) Communications System Operability/Capability Assessment and Modification (CSOCAM) indicates that a combat event has occurred which may alter the operability/capability of the communications system elements. CSOCAM instructions would be directed to the Environmental Effects Package of T-COR COMMO.
- (3) Communications System Status (CSS) reports to T-COR parameters indicating the status of the communications systems that have potential bearing on decisions made in T-COR.

Each R/D has associated with it a list of processing options that are selected by T-COR. Concentrating on the Communications Service Request (item one above), a range of actions occur in T-COR COMMO depending on the options selected by T-COR. For example, one qualified R/D might specify that a given message is to be transmitted between two specific users over a named communications system. We call this a well-defined R/D and expect as output from COMMO, a total delay time to complete this message transmission. A possible result, of course, is an infinite delay time response if the specified transmission system is incapable of successfully transmitting the message.

At the opposite end of the spectrum we have the "loosely" defined request. As an example, suppose T-COR issues an R/D which states: here is a user-pair between which communications is needed - what are the current means available and how are they performing? For each communications system-type between the specified pair, T-COR COMMO responds with their current availability and an indication of their performance caliber. The figure shows that several levels of R/D complexity exist between a completely defined R/D (no returned alternatives) and a loosely defined R/D resulting in essentially a status report of communication capabilities at the current time. A typical example of an intermediate R/D might be the following: T-COR indicates that message communications are needed between a specific user-pair, the information to be transmitted is record data and to use the fastest available system (including messenger) to transmit it. T-COR COMMO processes the request and reports to T-COR what systems was used and the expected time delay before successful transmission is completed.

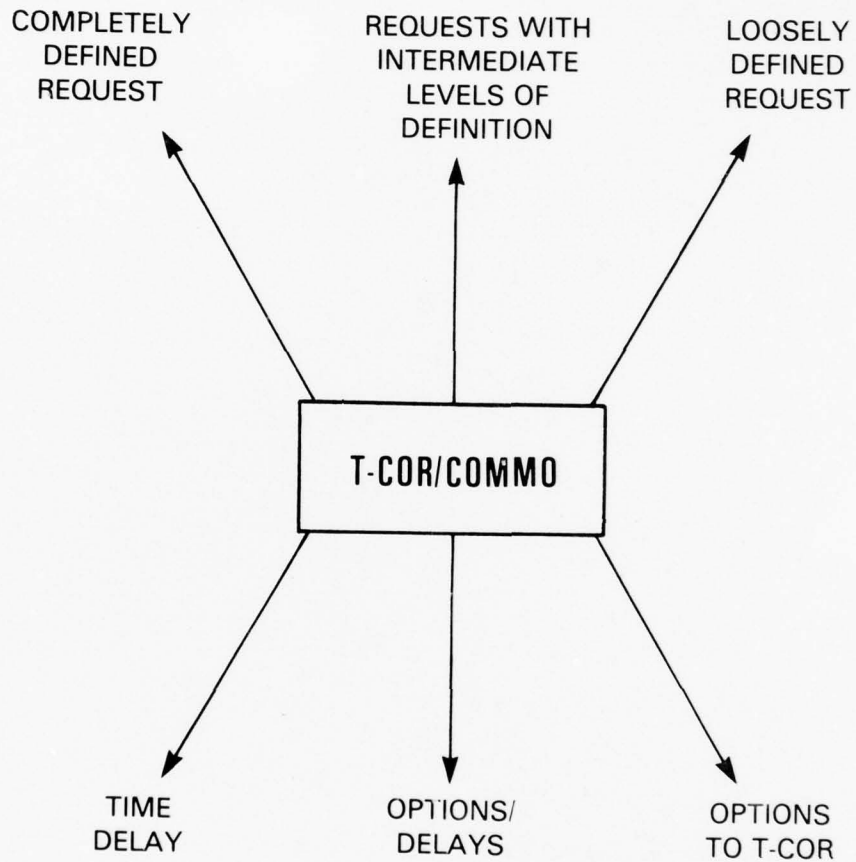

Figure 3.3. Request/Directives

3.4 Environmental Effects Program

The Environmental Effects Program assesses the effects on the operability/capability of the communications systems components at affected nodes for certain T-COR simulation generated and scheduled events and applies the appropriate modifications to the Service Matrix.

Combat and other environmental events generated by the T-COR simulation gaming and other scheduled events cause the system control software to trigger the Environmental Effects Program to assess possible changes in the operability/capability of communications components located at various nodes. Examples of simulation generated events which might effect the operability/capability of communication components are a nuclear burst, destruction of an enemy jammer, movement of a node or significant equipment/personnel losses due to conventional attrition. An example of a scheduled event would be restoration of a communications component that had failed at an earlier time. The nodes affected can be specified by T-COR, as in the case of movement of a node, or assessed by the Environmental Effects Program, as in the case of a nuclear burst at a location and yield that are defined by the T-COR gaming. If a high detail model is used which incorporates message queuing, message transmission completion times would be handled as scheduled events by T-COR and reported to T-COR COMMO for appropriate updating when they occur.

The Environmental Effects Program applies the appropriate changes, if any, to the Service Matrix elements. If the Service Matrix is changed it can be searched by routines in the COMMO Status File to update the connectivity file. Alternately the COMMO Status File can be left unchanged at these event times and only update when status report requests are made directly to the COMMO Status File by T-COR.

Computationally, the Environmental Effects Program would depend extensively on extant techniques and methodologies as applicable at the T-COR COMMO level of detail. A key source of both techniques and methodologies is the ETC³ wherein subroutines from ETC³ may be integrated directly into the Environmental Effects Program of T-COR COMMO. Furthermore, in the interests of computational efficiency, effects data resulting from the DNA sponsored INCA effort could be incorporated in T-COR COMMO through curve fit and/or data lookup table techniques.

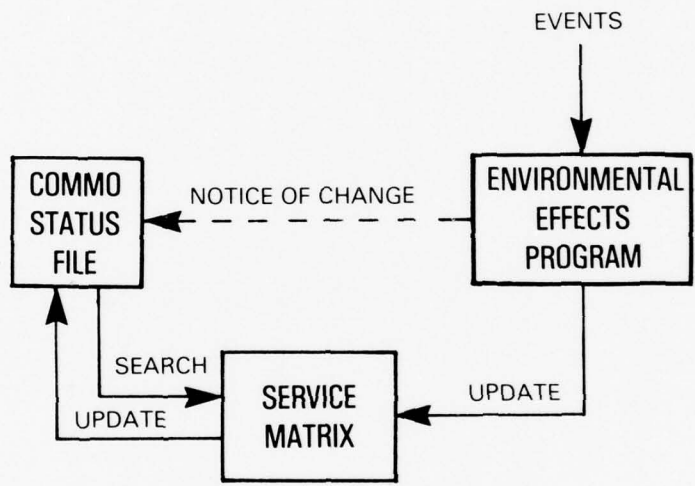

Figure 3.4. Environmental Effects Program

3.5 T-COR Net Structure

Each unit used in T-COR from Corps Rear to the maneuver units represent nodes in the System Description and associated with each of these nodes, as a message transmitter, is a two dimensional slice of the Service Matrix.

In the System Description, and conceptually in the T-COR COMMO Module, each unit in the detail portion of the T-COR game represents a communication network node. There are several communications networks identified by the type of communication transmission system, for example the FM/Secure Voice Command Net or the Microwave Multichannel LOS net. These networks are automatically interfaced at the appropriate nodes by the System Generator during the data input process.

If a node, N_k , is thought of as a sender or transmitter of messages then associated conceptually with that node is a two dimensional slice of the Service Matrix, with rows indexed by communication networks and columns indexed by nodes in the T-COR game. In this conceptualization if node N_k does not have an access to a particular communication network then all the entries in that row would indicate that no communication is possible, or equivalently that message time delays on that network are infinite. Likewise, in this conceptualization, if N_k cannot communicate with node N_j by some network which N_k has access to, then this entry in the matrix indicates that no communication is possible.

- EXAMPLE:**
- N_1 CORPS REAR
 - N_4 CORPS TACT OPS CNTR (CTOC)
 - N_5 DIV TACT OPS CNTR (DTCO)
 - \vdots
 - N_I

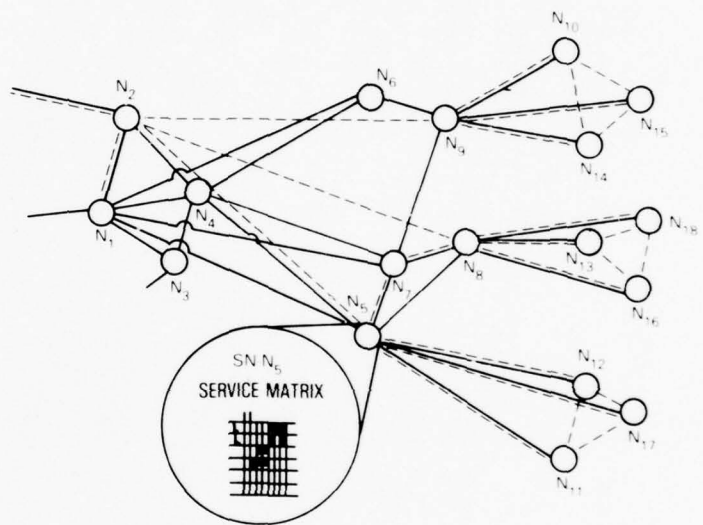

Figure 3.5. T-COR Net Structure

3.6 Service Matrix Structure

Request/directives from T-COR are processed by the T-COR COMMO Module by checking one or several entries in the send node slice of the Service Matrix, depending on the level of definition of the R/D.

Recall that the row indices of the send node slice of the Service Matrix correspond to communications networks and the columns to receive nodes (units) in the T-COR game. In practice only communications networks to which the send node ever has access are of interest. Referring to the figure which shows a detail of the send node slice of the Service Matrix, it is seen that there may be several means of communications between a given send and receive node. For organization and accessing reasons the communication network indices are grouped into two major classes; voice and text/record systems. Messenger type communications are classed as text/record and can be listed at the end of the text/record group. In practice message communication will be handled in a separate list structure to permit more compression of the Service Matrix.

A communications service Request/Directive (R/D) is issued from T-COR and processed by the T-COR COMMO Control Module by consulting the Service Matrix. The addressed element (send node, receive node, voice/text indicator and system) contains the processing delay or procedure for its determination as the output from T-COR COMMO for this R/D. If the specific voice or text system is not specified, then a downward search is conducted to find the first available system which can service the R/D.

A large degree of flexibility is allowed with respect to the definition or qualification level of an R/D. It can be fully qualified specifying a particular voice or text system, partially qualified specifying voice or text class and a subset of allowable systems, partially qualified specifying voice or text class and no system which invokes a top-down sequential search or unqualified such that a list of all available communications systems are determined.

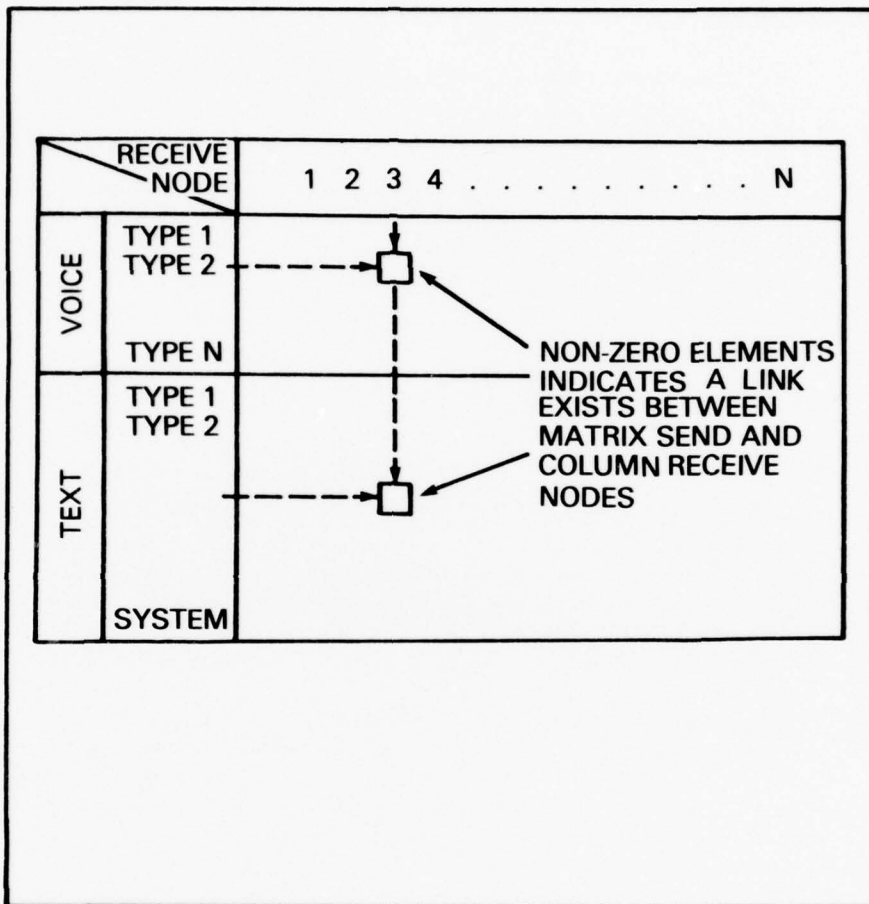

Figure 3.6. Service Matrix Structure

3.7 Service Matrix Elements

Each entry in the Service Matrix, referred to as an element, contains one or more communications processing parameters from which processing times can be determined consistent with the level of detail required.

Generally speaking, any communications event will consist of three distinct phases; preparation for transmission of the message, actual conveyance of the message between sender and receiver locations and receipt actions following the transmission phase. There is substantial variation in the size and content of these three phases among the communications systems employed at Corps and below.

Consistent with this concept, each element of the Service Matrix provides for the existence of these three communications processing phases for any message type. The total message transmission delay time is then given by the sum of these three delay time contributions.

The message processing delay time can be direct or computed depending on several factors including the T-COR COMMO user's required level of detail. In the interest of T-COR execution speed, T-COR COMMO may provide three techniques for the determination of communications processing delay time for each phase of processing as follows:

- (1) Time Delay Form - This is the simplest and fastest technique. A processing delay time factor is pre-computed and stored as elements of the Service Matrix that are appropriate for the communication system type and status. A typical example might be record data transmission system where the transmission delay would be given by the product of this factor and the message length.
- (2) Computational Procedure - The computational procedure is provided for those communications systems, communication processing phases, or volatile situations that are highly dependent on dynamic factors in the T-COR game. In this case the element of the Service Matrix points to the appropriate special computations contained or addressed in the T-COR COMMO Module.
- (3) Distributional Time Delay Form - In this form an element of the Service Matrix would contain the parameters that characterize the probability distribution of the processing delay times. Either T-COR COMMO or T-COR itself would then be responsible for the appropriate utilization of these distribution parameters. While this technique would seem to represent more realistically the

actual delay process, the validity of the parameters to be used would be highly dependent on the quality and quantity of statistical data available to determine the distributional forms and parameters characterizing those distributional forms.

It should be noted that combinations of the above three techniques for the three phases of the communication event are possible if the level of detail requirements so dictate.

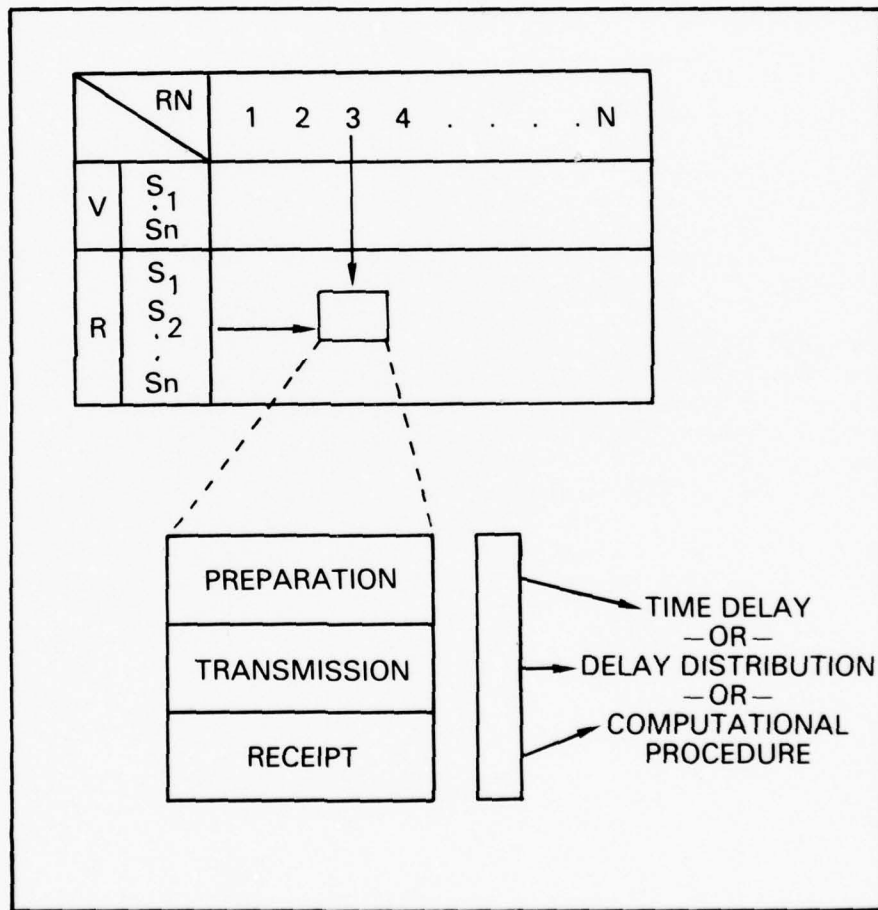

Figure 3.7. Service Matrix Elements

3.8 Message Delays for Record/Data

Record-data type communication systems typically encompass message handling processes which have considerably larger time delays associated with them than the transmission itself.

At an originating node, the start of the communications system processing usually begins with the receipt of the message at a message or communications center and is called the time-of-file (TOF) for that message. Following TOF, the message must be physically handled by message center personnel in preparation for electrical transmission which often includes punching and verification of a paper tape.

When the message is physically entered into the electrical transmission system or a queue for electrical transmission, this is marked by the start-send segment of the end-to-end message communications process. The duration of this segment is determined by such factors as message length, message precedence, transmission speed, error rate, queing and alternate routing. Note that, if the electrical transmission system is not available for access or is inoperative, the transmission time is infinite.

When the electrical transmission to the receiving node is complete and acknowledged, the transmission segment is complete and we enter the receiver handling segment. Included in this final segment might be hard copy generation of the message and, in all cases, actual delivery of the message to the named addressee (s). Performance of the latter action is designated the time-of-delivery (TOD) of the message.

In many record data communication systems, the TOF to TOD time span will include one or more intermediate nodes where personnel actions are required such as, for example, in torn-tape relay. These cases are accommodated in T-COR COMMO by recognition of intermediate node status which modifies the derivation of the total processing time.

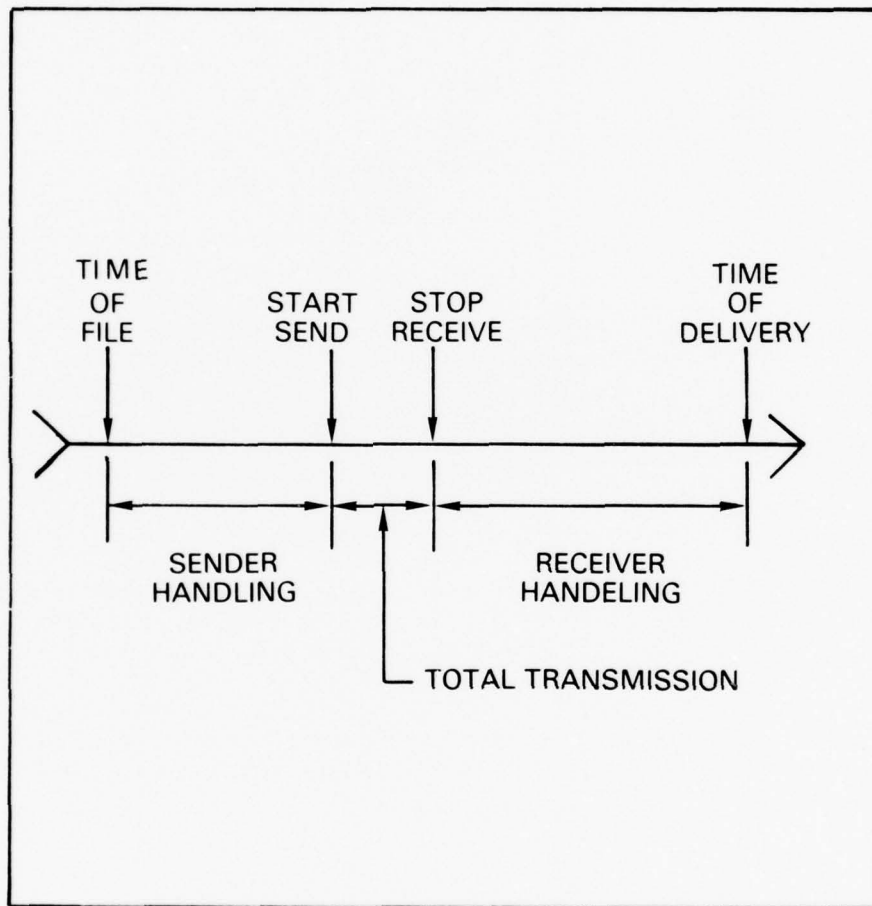

Figure 3.8. Message Delays for Record/Data

3.9 Intermediate Processing

Communication system nodes serving message traffic on an intermediary basis can automatically select and forward messages to the final destination.

Communications in the combat theater are typified by a collection of several different system-types interfacing at the various command echelon headquarters. The size, sophistication and complexity of these interface nodes tends to increase as we progress from the forward (company level) to the rear area (Corps headquarters).

The relaying of message traffic through these nodes is a normal part of tactical communications and hence is represented in T-COR COMMO. Frequently, human actions are required in the processing and relaying of traffic through these intermediate nodes as, for example, in torn-tape-relay. A statistical characterization of communications operations personnel actions representing the process is employed in the COMMO model and is sensitive to such parameters as number of personnel, traffic activity, message precedence and message quality.

In many cases, the choice of message forwarding means is simple in that only one means is (or ever was) available to get to the destination subscriber (excluding messenger) and may or may not involve a transmission system-type change. However, in some cases there will be more than one means available to forward messages and a selection process must be invoked. Control of this selection process is provided by a doctrine table which specifies the permissible interfaces, their preference of selection and any special considerations which must be applied.

It is important to note that T-COR always has the capability to override the communications node doctrinal interface processing by simply using the node as a destination for the initial message leg and as an origin for the second or final leg of the end-to-end path.

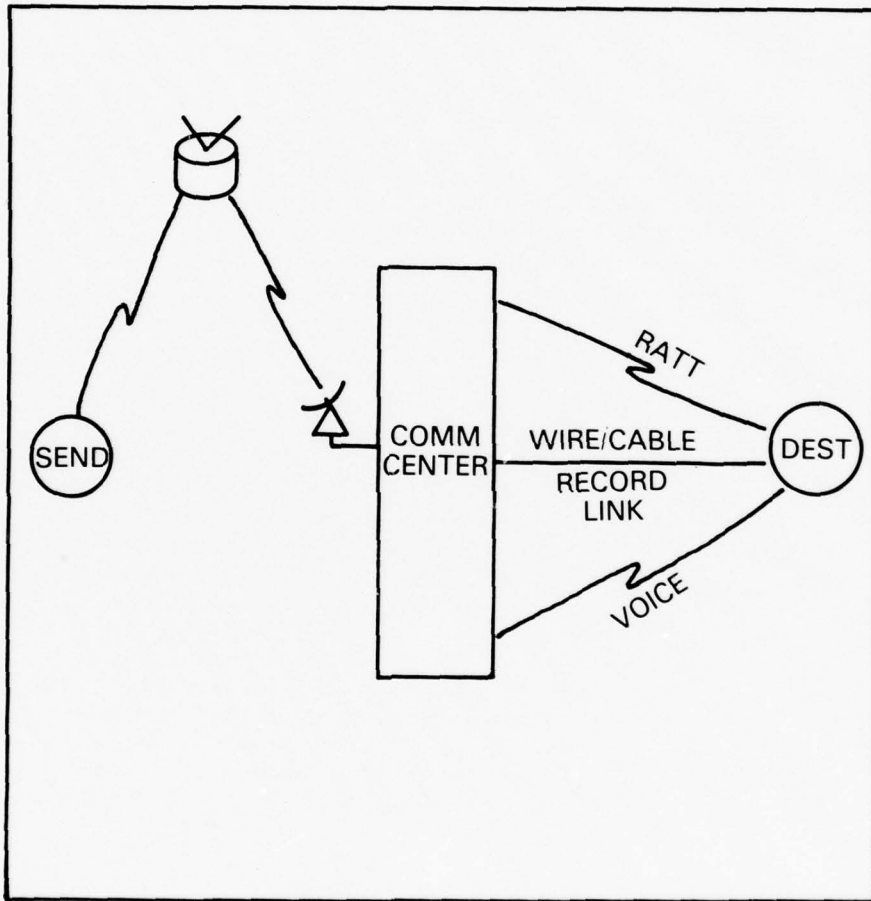

Figure 3.9. Intermediate Processing

3.10 Message Integrity

Variability in operational capability as well as hostile or friendly combat events can impact message clarity and integrity.

The existence of a nominal communications link between two nodes does not guarantee that sufficiently accurate messages can be passed over that link. Message clarity is generally related to average intelligibility for voice messages and character error rate or bit error rate for text/record and digital messages, respectively.

A number of environmental effects, combat and non-combat related, can impact on message integrity. Non-combat factors that can impact on voice intelligibility include range of transmission, weather effects such as rain, and both gross and local terrain features. Similarly, combat effects such as jamming, RF interference, and loss of power or high gain antennas can adversely effect voice intelligibility without completely eliminating the communications link.

Record/data and digital links are also subject to variability in the quality of transmission due to combat and non-combat related effects. An important example is the possible large increase in bit-error rate for satellite communications links that may result following a high altitude nuclear burst.

The impact of reduction in average voice intelligibility and increase in character or bit-error rate is highly dependent on the type of message being transmitted and the available procedures for retransmission and message piecing. Clearly for most voice messages repetition can be used to assure message integrity. For critical record/data or digital messages repeated transmission may also be used to insure message integrity. However, in the absence of retransmission procedures, faulty data may be passed undetected due to increases in error rate.

T-COR COMMO does not propose to calculate directly message integrity, however, the impact of selected combat and non-combat effects on message integrity can be included in the T-COR COMMO model. The special delay codes subordinate to the Service Matrix can be used to calculate message integrity effects for selected critical cases. Additionally, the distributional form for the Service Matrix delays would be an excellent vehicle for inclusion of abnormal delays due to reductions in voice intelligibility.

EFFECTS:

VOICE INTELLIGIBILITY
CHARACTER ERROR RATE
BIT ERROR RATE

CAUSES:

TERRAIN
WEATHER
NUCLEAR WEAPONS
PHYSICAL DISPOSITIONS

MODELS:

SPECIAL DELAY CODES
DISTRIBUTIONAL PARAMETERS

Figure 3.10. Message Integrity

3.11 Messenger Service

Messenger-type communications delays are determined as a function of transmission mode, sender-receiver separation and terrain/weather conditions.

The fundamental messenger-type communications modes allowed in T-COR COMMO include air (helicopter), ground vehicle (jeep) and foot. Each mode or system type is initially assigned a nominal average speed-of-service. When a messenger system is selected by T-COR (or T-COR COMMO when permitted), the line-of-sight distance between the centers of the sender hex and receiver hex is determined. Then the nominal message delivery time is simply the quotient of this distance and the nominal mode velocity.

To correct the nominal delivery time delay for terrain and weather conditions, a terrain traversal difficulty factor for each hex in the delivery route for the selected messenger node and the prevailing weather factor can be applied. That is, the product of the terrain factor for each hex, the weather factor and the nominal delivery time gives the corrected delivery time.

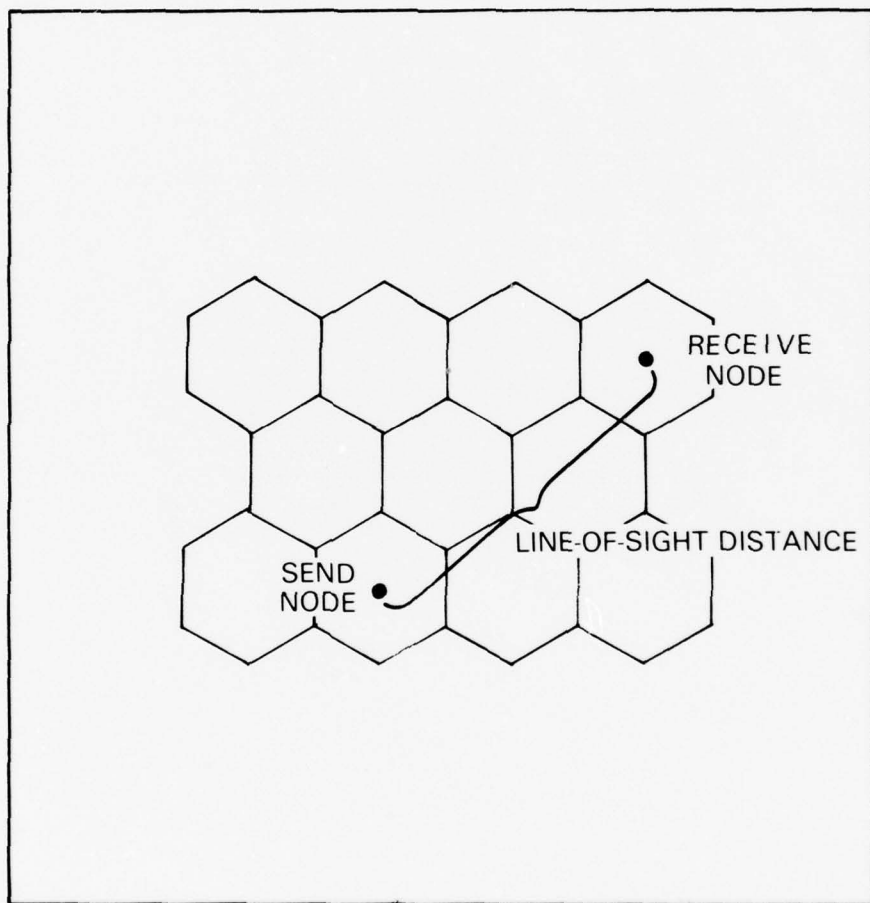

Figure 3.11. Messenger Service

3.12 Combat Environmental Effects

The primary combat and environmental effects that influence the operability/capability of the communications components at the nodes are electromagnetic jamming, damage from conventional and nuclear weapons, and movement of nodes.

As mentioned earlier, T-COR sends notice to T-COR COMMO of the occurrence of events which could potentially cause a change in the operability/capability of communications components located at the various nodes. The Environmental Effects Program module in T-COR COMMO then evaluates the event and makes the appropriate updates to the Service Matrix. The most important types of events which can impact on communication operability/capability are changes in electromagnetic jamming, conventional firepower, nuclear weapons detonations, and movement of nodes.

Electromagnetic jamming can cause communications systems such as FM nets to be completely jammed, partially jammed, or not jammed. The effect of increased jamming is to increase the message transmission time until at some threshold the transmission time becomes infinite, corresponding to no communication capability on the affected communication system at the node.

Conventional and nuclear detonations cause gross inoperabilities or in some cases decreases in the capability of communications components. An example of a decrease in capability would be the loss of a major portion of the communications personnel at a particular node resulting in large increases in message handling times.

Movement of nodes causes the temporary loss of communications capability in nearly all networks except FM nets and messengers while the node is preparing to move, while moving, and for a period of time after the node has reached a new location. Additionally, relocation may cause loss of some node-to-node radio communication because of range limitations, while making feasible other node-to-node communication that was previously infeasible.

In addition to the important effects mentioned above, high detail models are possible which incorporate other effects such as weather and message queuing. Also many types of communications systems which have been damaged due to detonations can be reconstituted in relatively short periods of time (relative to the game time). Consistent with the level of detail required such reconstitution events should be fed back to T-COR to be scheduled.

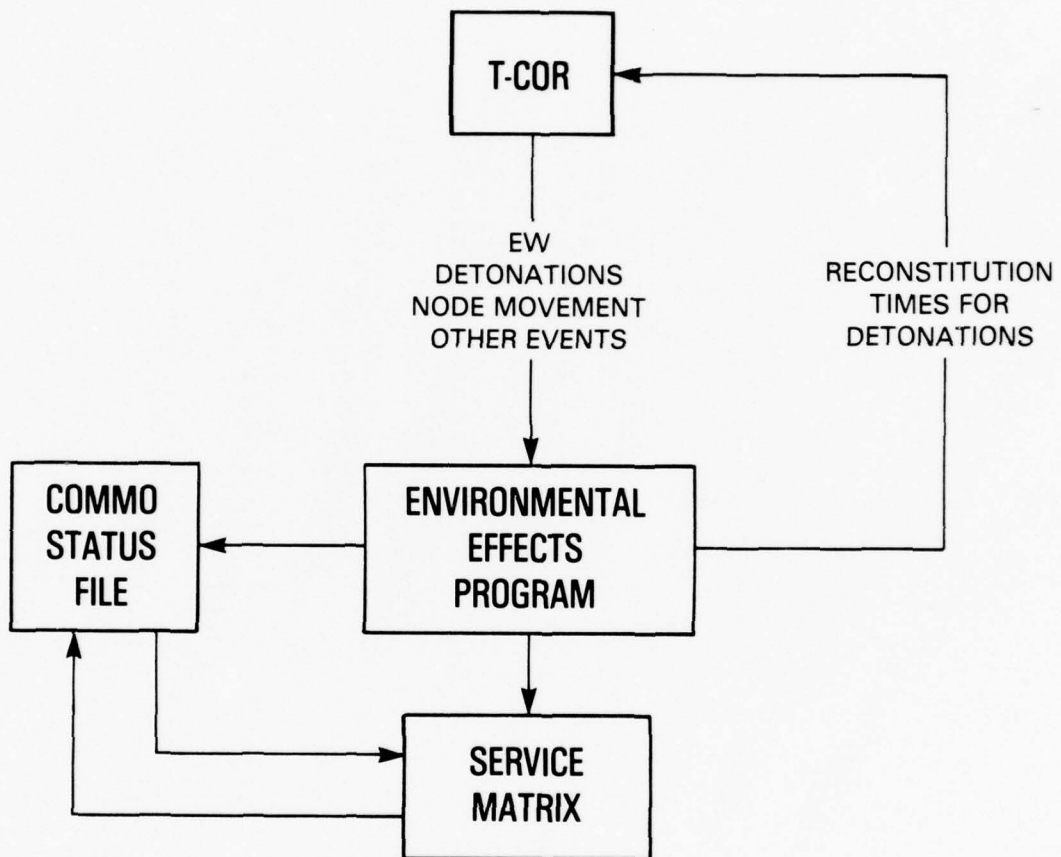

Figure 3.12. Combat Environmental Effects

3.13 Electronic Warfare

Electronic Warfare (EW) is a significant threat to communications in the theater and is, therefore, included in T-COR COMMO by a first-order model addressing radio links.

The scope and sophistication of radio communications jamming alone (as a subset of EW) is extensive and complex. The effectiveness of a particular jammer against a particular radio link (receivers) is a function of a very large number of parameters characterizing the jammer, receiver(s) and the physical/electrical environment between them.

T-COR COMMO can address the jamming of radio links with a very straightforward first-order model. Each jammer played has a maximum effective jamming radius associated with it. Any receiver located in a hex that is totally within the effective jamming radius is considered totally jammed and ineffective for both transmit and receive operation. For those receivers located within hex's through which the line of effective jamming radius passes, either total jamming or no jamming will be assessed according to the toss of a coin.

Each jammer also has a "type" designator associated with it and each receiver node may be marked as susceptible or not susceptible to any subset of the jammer types. Using this capability, a first-order approximation can be made to account for such variables as jammer type, power, directivity and receiver frequency, antenna characteristics (gain, direction, etc) as a few examples.

While more representative models of jamming are fairly easily obtained, the preceding approach should prove initially adequate, is consistent with T-COR COMMO level-of-detail, and is easily refined.

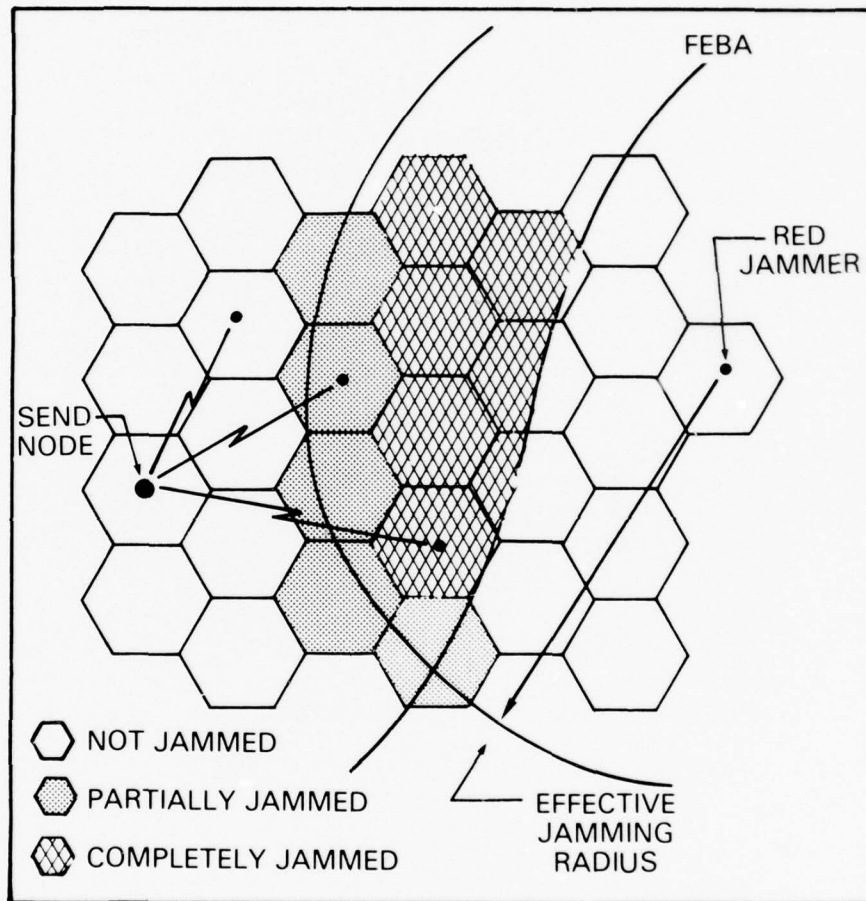

Figure 3.13. Electronic Warfare

3.14 Conventional Weapons Effects

Conventional weapon detonations affect communications by producing gross inoperabilities in communication components and by reducing capability through personnel losses.

There are three major considerations in assessing the conventional weapon damage to communication system components: (1) destructive capability of the weapon or weapons, (2) vulnerability of the components, and (3) distance from the detonation to the communication components. Since T-COR allocates conventional weapons on an area basis, a conventional detonation event reads as one or more detonations of a specified destructive capability occurring in a specified hex. Since hexes are at minimum 1.35 km center to center, it is a good first order approximation to examine only nodes located in the specified hex for changes in operability/capability due to the given event. Consideration (3) then becomes one of weapons coverage.

Within the hex specified by the detonation events, gross component inoperabilities and personnel losses are probabilistic events. The probabilities associated with these communication events are produced as outputs of a weapons coverage subroutine to which the parameters; number of detonations, destruction capability per detonation, communication component vulnerability, and number of communication personnel assigned is passed. With these probabilities either T-COR or the T-COR COMMO itself makes random draws to determine the specific communication components damaged and number of personnel lost. These losses are then translated into changes in communications capability and the new status is entered in the Service Matrix. Consistent with the level of detail required, the weapons coverage subroutine will be developed as a fast running computation which is condensation of results already treated in T-COR.

As noted earlier in this chapter some types of communication systems losses which have occurred because of component failures can be reconstituted in a time that are short by comparison to the T-COR game. Consistent with the level of detail required, system loss events due to this category of failures should generate a mean or random reconstitution time which is sent to T-COR for scheduling.

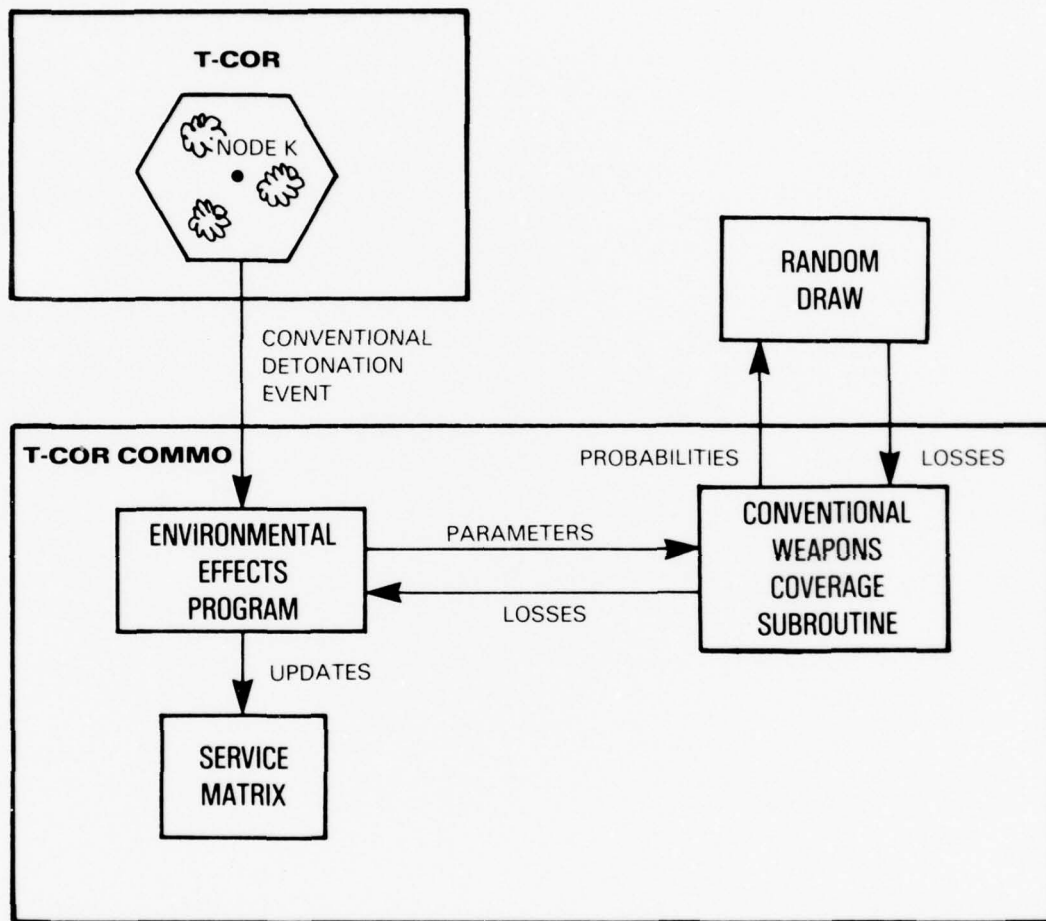

Figure 3.14. Conventional Weapons Effects

3.15 Nuclear Weapons Effects

Nuclear weapons detonations impact communication system operabilities/capabilities at all nodes within hexes which have centers less than a radius R_{MAX} from the center of the hex in which the detonation occurred, where R_{MAX} is a function of the weapon yield.

Unlike conventional weapons, nuclear weapons can cause communication system losses at large distances and by several destructive effects. Thus it is not a valid approximation to look only at the hex in which the detonation occurs or even to include only the hexes adjacent to the detonation hex.

For all typical low altitude tactical yields at typical heights of burst, loss of all personnel is essentially certain within 0.7 kilometers of the weapon ground zero. Since electronic component losses due to neutrons are similar to personnel losses, all communications systems located in the hex where the detonation occurred are considered completely destroyed with no possibility of reconstitution.

Along with the ground zero location of nuclear bursts T-COR will supply the nuclear weapon yield and height of burst. From this information T-COR COMMO will compute the radius R_{MAX} , a function of yield and height of burst, which corresponds to the maximum radius where nuclear weapons effects are considered significant; for example the 99 percentile radius for damage to a soft communications system. For each node located in a hex with a center located in a circle of radius R_{MAX} about the center of the detonation hex, the Environmental Effects Program will access communication system nuclear vulnerability subroutines which will produce probabilities associated with gross inoperability and/or levels of capability of the communication system at that node. T-COR or T-COR COMMO itself will then conduct random draws to define the damage to specific communication systems, the damage will be translated to changes in message delays and entered in the Service Matrix. As in the case of conventional detonations, reconstitution capabilities can be included if the level of detail dictates.

At the heart of the nuclear detonation damage calculations are the nuclear vulnerability routines. These routines will be fast running out-growths, probably curve fits, of the nuclear survivability/vulnerability models that BDM is developing under INCA for the communications systems of Corps and lower echelon units.

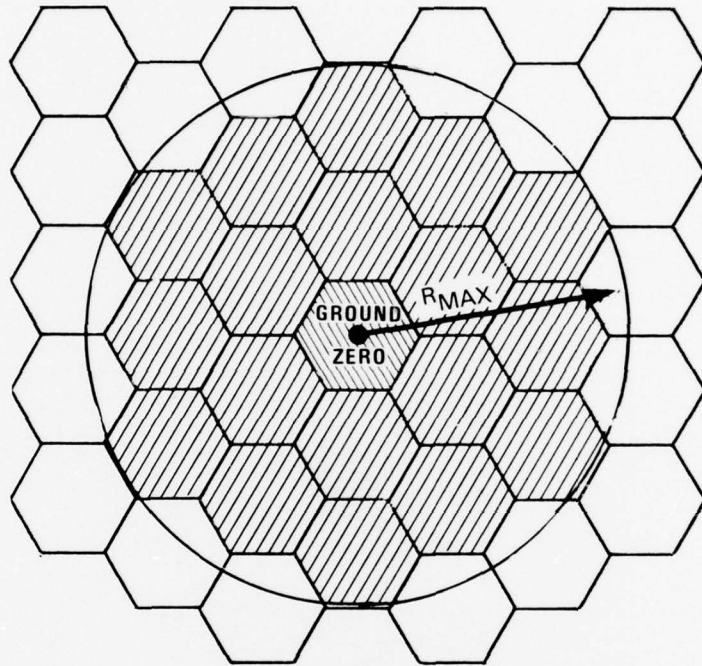



-  TOTAL DESTRUCTION
-  SUBROUTINE COMPUTED LOSSES
-  NOT VULNERABLE

Figure 3.15. Nuclear Weapons Effects

3.16 Additional Levels of Detail

Requirements for high level detail will introduce complexity which will increase both the run times and computer memory requirements in T-COR and T-COR COMMO.

While the introduction of weather, message queuing, random non-enemy action caused malfunctions of communications components, and communication system reconstitution capability will be expected to increase the realism of T-COR, the data structure needed to model these features will increase complexity and run time of T-COR significantly.

Weather affects radio transmission reliability and hence will affect transmission times. Queuing of messages at busy nodes can result in increased message times. Random malfunctions of communication components can cause loss of the affected system until the malfunction is corrected. Other features can be identified that will affect message times, but all will result in an increase in the data structure complexity. Many of the above features not only require additional computations and branching, but also require maintenance of a comprehensive history record. For example, consider the case where a communication component malfunction event occurs and a time of repair or reconstitution is scheduled, and subsequent to this event but before the reconstitution event this communication system is subject to combat effects which would have destroyed the system. Unless some memory exists as to the tentative status of the communication system, no additional destruction on the system will be recorded and when the scheduled reconstitution time arrives the system will be made operable again. When overlapping periods of reconstitution are considered the number of troublesome scenarios increases. In order to avoid an error, comprehensive histories on all system (and maybe even system components) must be maintained and searched at most events that affect that system. This requirement results in significant degradation of the T-COR COMMO Module efficiency.

While comprehensive models of message queuing are in concept the same type of history problem mentioned above, in practice they result in very large increases in run time and memory requirements because of the number of messages involved and the frequency with which they must be processed.

A well reasoned balance between the need for detail and efficient run times is required for development of T-COR COMMO. Clearly no detail finer than that inherent to T-COR itself is justified.

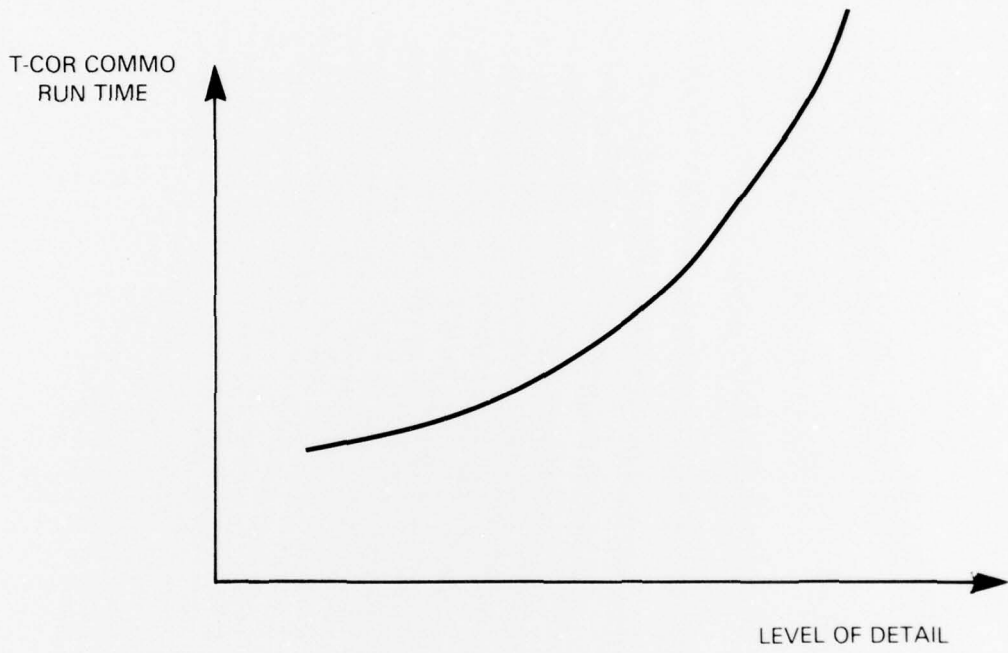

Figure 3.16. Additional Levels of Detail

3.17 Communications Systems Data Base

The communications system is defined, organized and stored in an offline data base using a stand-alone program dedicated to this function.

All of the requisite parameters characterizing a total communication system for T-COR COMMO are input to a System Generator program which produces a System Description data base. This data base is then subsequently read as input to T-COR COMMO via the T-COR SCS at run initialization time. As part of this initialization process, a limited but comprehensive set of data base modification directives may be optionally specified and applied to the external data base resulting in a derivative internal communication system configuration/characterization. An example of such a modification would be changes to the communications system to input to model random, combat independent equipment failures. Such a case would also require the generation and storage in T-COR's event list of the restoration times for those pieces of equipment.

The figure identifies the fundamental data inputs to the System Generator which are appropriately processed, formatted and entered into the System Description data base. Three distinct data-type categories are identified as well as their key characterization parameters. Since the theater communications system is typically composed of several independent networks, a separate category of Network Interfaces and Interoperabilities is established. For the most part these interfaces would be either automatic at the common nodes or at least well-characterized (including any human action/interaction). T-COR itself always retains the capability to evaluate and select among alternatives at any communications network interface node. Finally, we recognize that multichannel transmission media are employed from which more than one independent network may derive part of its connectivity. Because the loss or reduction in capacity of these transmission systems potentially affects a number of networks, their definition and characterization is maintained in a separate region of the System Description data base.

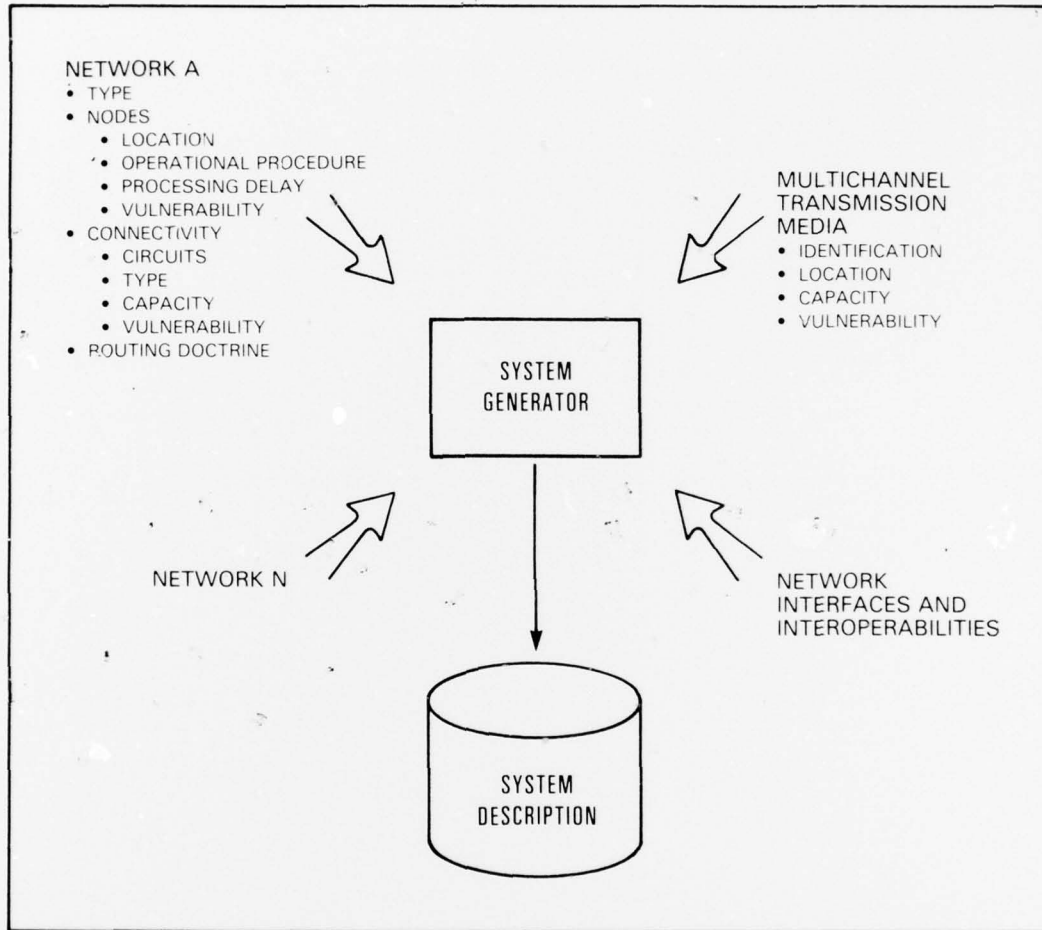

CHAPTER IV
IMPLEMENTATION

CHAPTER IV

IMPLEMENTATION

4.1 Implementation Outline

The approach to implementing T-COR COMMO stresses early identification of critical data and subroutines through sensitivity analysis.

The T-COR COMMO conceptual design discussed above has the need for flexibility and the capability to include varying levels of detail. The approach to the detailed design, coding, and check out of T-COR COMMO will be to build a relatively simple baseline model with a limited data base and, through sensitivity analysis, to determine those portions of the model with the greatest impact on T-COR.

The initial T-COR COMMO model will include, as a minimum, the Service Matrix, Environmental Effects routines, and the modification of the T-COR control software to provide the necessary interaction with T-COR COMMO. Initial entries to the Service Matrix will be provided using primarily operational experience with a minimum of detailed analysis. The form of the environmental effects subroutines will be established and existing data used to code the algorithms.

With the establishment of a working basic T-COR COMMO module, sensitivity analyses will be conducted using T-COR to determine the impact of the new T-COR COMMO module on the T-COR main game. These sensitivity studies will be of two types: (1) Simple variations of Service Matrix elements and environmental effects parameters and (2) substitution of higher level-of-detail submodels. The objective of the sensitivity studies is to determine which submodels and which parameters have the greatest effect on T-COR and hence should be developed most fully.

Documentation of the initial implementation will consist of a users guide which explains the basic workings of T-COR COMMO and the data that is incorporated into the model. Additional documentation will define the data requirements to make T-COR COMMO fully operational as well as those improvements deemed necessary as a result of the sensitivity analyses.

IMPLEMENTATION

- **CODE THE BASIC T-COR COMMO**
 - SERVICE MATRIX
 - ENVIRONMENTAL EFFECTS
 - T-COR SOFTWARE
- **PROVIDE INITIAL DATA BASE**
 - SERVICE MATRIX ELEMENTS
 - EFFECTS SUBROUTINES
- **SENSITIVITY ANALYSIS**
 - VARY PARAMETERS
 - INCLUDE TEST MODIFICATIONS
 - DETERMINE T-COR IMPACT
- **DOCUMENTATION**
 - USERS GUIDE
 - DATA REQUIREMENTS
 - NEEDED IMPROVEMENTS

Figure 4.1. Implementation

DISTRIBUTION LIST

DEPARTMENT OF DEFENSE

U.S. Documents Officer
A.F. South
ATTN: U.S. Documents Officer

Armed Forces Staff College
ATTN: Reference & Technical Services Branch

Assistant Secretary of Defense
Comm. Cmd. Cont. & Intell.
ATTN: Stra. & Theater C&C System
ATTN: Survl. & Warning System
ATTN: Assistant for NATO C³

Assistant Secretary of Defense
Program Analysis & Evaluation
ATTN: General Purpose Programs

Assistant Secretary of Defense
Manpower Reserve Affairs & Logistics
ATTN: Dep. Asst. Secy. Program Development

Assistant to the Secretary of Defense
Atomic Energy
ATTN: B. Adams
ATTN: Executive Assistant

Command & Control Technical Center
Department of Defense
ATTN: C-600
ATTN: C-330

U.S. European Command
ATTN: J-6
ATTN: J-5NPG
ATTN: J-417-LW
ATTN: J-2
ATTN: J-2-FTD
ATTN: J-3
ATTN: FCJ6-PF

Commander-In-Chief, Pacific
ATTN: J-6
ATTN: J-54
ATTN: J-2
ATTN: J-3

Defense Advanced Rsch. Proj. Agency
ATTN: TIO

Defense Communication Engineer Center
ATTN: Code R123
ATTN: Code R400
ATTN: Code R720

Defense Communications Agency
ATTN: Code 410
ATTN: Code 205
ATTN: Code 510
ATTN: Code 101B
ATTN: Code 520
ATTN: Code 530

Defense Documentation Center
12 cy ATTN: DD

DEPARTMENT OF DEFENSE (Continued)

Defense Intelligence Agency
ATTN: DT-4B
ATTN: RDS-3A
6 cy ATTN: DT-1B

Defense Nuclear Agency
ATTN: STSP
ATTN: STRA
ATTN: DDST
ATTN: OAPO
ATTN: STNA
ATTN: STVL
ATTN: VLIS
ATTN: STSS
4 cy ATTN: TTTL

Director Net Assessment
Office of the Secretary of Defense
ATTN: Military Assistants

Field Command
Defense Nuclear Agency
ATTN: FCPR
ATTN: FCP-FCPRK

Interservice Nuclear Weapons School
ATTN: TIV

Joint Chiefs of Staff
ATTN: J-3 NMCC
ATTN: J-3 Nuclear Weapons Branch
ATTN: J-3 Nuclear Contingency Branch
ATTN: J-3 WWMCCS Council Support Office
ATTN: SAGA
ATTN: J-5 Nuclear Division
ATTN: J-3 WWMCCS Evaluation Office
ATTN: J-3

Joint Strat. Tgt. Planning Staff
ATTN: JSAS
ATTN: NRI-STINFO Library
ATTN: JPST
ATTN: JLTW-2
2 cy ATTN: JL

Joint Tactical Communications Ofc.
ATTN: TT-E-SS

Livermore Division Fld. Command DNA
ATTN: FCPRL

National Communications System
Office of the Manager
Department of Defense
ATTN: NCS-TS

National Security Agency
Department of Defense
ATTN: TDL
ATTN: R-52, O. VanGunten

U.S. Forces Korea
ATTN: CJ-P-G
ATTN: DJ-AM-SM

DEPARTMENT OF DEFENSE (Continued)

U.S. National Military Representative
SHAPE
ATTN: U.S. Documents Officer

Under Secy. of Def. for Rsch. & Engrg.
Department of Defense
ATTN: Research & Advanced Technology
ATTN: Tactical Warfare Programs
ATTN: Strategic & Space Systems (OS)

WWMCCS System Engineering Org.
ATTN: WWMCCS/SEE

DEPARTMENT OF THE ARMY

Asst. Chief of Staff for Intelligence
Department of the Army
ATTN: DAMI-FI

Atmospheric Sciences Laboratory
U.S. Army Research & Development Command
ATTN: DELAS-AS

Deputy Chief of Staff for Ops. & Plans
Department of the Army
ATTN: DAMO-TCW
ATTN: DAMO-SSP
ATTN: DAMO-RQS
ATTN: Technical Advisor

Deputy Chief of Staff for Rsch. Dev. & Acq.
Department of the Army
ATTN: DAMA-CSS-N
ATTN: Advisor for RDA Analysis

Harry Diamond Laboratories
Department of the Army
ATTN: DELHD-N-CO
ATTN: DELHD-N-RBA
ATTN: DELHD-N-NP
2 cy ATTN: DELHD-N-RBH/DELHD-N-TI
2 cy ATTN: DELHD-N-EM

C-E Services Division
U.S. Army Communications Command
ATTN: CEEO-7

Multi Service Communications Systems
Department of the Army
ATTN: DRCPM-MSCS-APB

U.S. Army Ballistic Research Labs.
ATTN: TBL
2 cy ATTN: CAL/VL

U.S. Army C-E Engrg. Installation Agency
ATTN: CC-EMED-PED
2 cy ATTN: CCC-PRSO/CCC-SEO

U.S. Army Comb. Arms Combat Dev. Acty.
ATTN: ATCA-CO
ATTN: ATCA-CA
ATTN: ATCA-CFT

U.S. Army Communications Command
ATTN: ACC-FD-C
ATTN: ACC-FD-M
ATTN: ACC-OPS-SM
ATTN: ACC-OPS-UR

DEPARTMENT OF THE ARMY (Continued)

U.S. Army Comd. & General Staff College
ATTN: ATSW-TA-D

U.S. Army Communications Sys. Agency
ATTN: SCCM-AD-SV

U.S. Army Concepts Analysis Agency
ATTN: Code 605/606

U.S. Army Electronics Rsch. & Dev. Command
ATTN: DRCPN-TDS-SD
ATTN: DRCPM-ATC

U.S. Army Europe and Seventh Army
ATTN: ODCSE-E AFAGE
ATTN: AEAGC-DSW
ATTN: AEAGB
ATTN: AEAGD-MM
ATTN: AEAGC-O

U.S. Army Materiel Sys. Analysis Activity
ATTN: DRXSY-S
ATTN: DRXSY-DS

U.S. Army Missile R&D Command
ATTN: DRSMI-YDR

U.S. Army Nuclear & Chemical Agency
ATTN: Library for ATCN-W
ATTN: Library

U.S. Army Satellite Comm. Agency
ATTN: TACSAT Office
ATTN: DRCPM-SC-11

U.S. Army TRADOC Systems Analysis Activity
ATTN: ATAA-EAC
ATTN: ATAA-TAC

U.S. Army Training and Doctrine Comd.
ATTN: Technical Library
ATTN: ATORI-OP-SD

U.S. Army War College
ATTN: Library

V Corps
Department of the Army
ATTN: AETVGB
ATTN: AETVCE
ATTN: AETVGC

VII Corps
Department of the Army
ATTN: AETSGC
ATTN: AETSGB-O
ATTN: AETSCE

DEPARTMENT OF THE NAVY

Command, Control & Comm. Progs.
Department of the Navy
ATTN: OP 941

Naval Ocean Systems Center
ATTN: Research Library

DEPARTMENT OF THE NAVY (Continued)

Naval Surface Weapons Center
ATTN: Code F31

Office of the Chief of Naval Operations
ATTN: OP 604, E/F
ATTN: OP 96
ATTN: OP 94

U.S. Atlantic Fleet
Department of the Navy
ATTN: Code J54
ATTN: Code J611A

U.S. Naval Forces, Europe
ATTN: N326

DEPARTMENT OF THE AIR FORCE

Aerospace Defense Command
ATTN: ADCOM/INA
ATTN: INW
ATTN: Commander

Air Force Weapons Laboratory
ATTN: EL
ATTN: DYC
ATTN: SUL

Assistant Chief of Staff
Intelligence
Department of the Air Force
ATTN: INAK

Assistant Chief of Staff
Communications & Computer Resources
Department of the Air Force
ATTN: AF/KRC

Deputy Chief of Staff
Operations Plans and Readiness
Department of the Air Force
ATTN: AFXOXM
ATTN: AFXOC

Deputy Chief of Staff
Research, Development, & Acq.
Department of the Air Force
ATTN: AFRDQSM
ATTN: AFRDQSN

Deputy Chief of Staff
Programs & Analyses
Department of the Air Force
ATTN: PACGC
ATTN: PACSC

Electronic Systems Division, AFSC
ATTN: Technical Library
ATTN: XRE

Foreign Technology Division, AFSC
ATTN: NICD Library

Space & Missile Systems Organization/SK
Air Force Systems Command
ATTN: SKA

DEPARTMENT OF THE AIR FORCE (Continued)

Strategic Air Command/XPFS
ATTN: XPFS

Tactical Air Command
ATTN: DRA

U.S. Air Forces in Europe
ATTN: XPXX

OTHER GOVERNMENT AGENCY

Central Intelligence Agency
ATTN: RD/SI, RM 5G48, HQ Bldg. for OSR/SF
ATTN: RD/SI, RM 5G48, HQ Bldg. for OSR/SFC

DEPARTMENT OF DEFENSE CONTRACTORS

BDM Corp.
ATTN: W. Sweeney, Jr.
ATTN: L. Jacobs
ATTN: Corporate Library
ATTN: R. Schmidt
ATTN: R. Rothrock/P. Riedl

Boeing Co.
ATTN: R. Scheppe

Commander, 66th MI Group
ATTN: RDA

Computer Sciences Corp.
ATTN: Library
ATTN: H. Blank

ESL, Inc.
ATTN: J. Dyche
ATTN: Library
ATTN: J. Marshall

General Electric Company—TEMPO
Center for Advanced Studies
ATTN: DASIAAC

General Electric Company—TEMPO
ATTN: DASIAAC

Institute for Defense Analyses
ATTN: D. Signori
ATTN: Classified Library

Kaman Sciences Corp.
ATTN: W. Long

Mission Research Corp.
ATTN: S. Gutsche

GTE Sylvania
Electronics Systems Grp. Eastern Div.
ATTN: M. Cross

R&D Associates
ATTN: Technical Information Center
ATTN: R. Schaefer
ATTN: R. Poll
ATTN: C. MacDonald

R&D Associates
ATTN: R. Latter

DEPARTMENT OF DEFENSE CONTRACTORS (Continued)

SRI International
ATTN: C. Shoens
ATTN: W. Jaye

DEPARTMENT OF DEFENSE CONTRACTORS (Continued)

RCA Corp.
ATTN: E. VanKeuren
TRW Defense & Space Sys. Group
ATTN: R. Webb