

18

17

AFHRL TR-7847

② LEVEL II
NW

AIR FORCE



⑥

MEASURING TROUBLESHOOTING SKILLS USING
HARDWARE-FREE SIMULATION

By

William J. Mallory
Thomas K. Elliott

Applied Science Associates, Inc.
Box 158
Valencia, Pennsylvania 16059

DDC

RECEIVED
JAN 31 1979
B

TECHNICAL TRAINING DIVISION
Lowry Air Force Base, Colorado 80230

ADA064054

DDC FILE COPY

HUMAN RESOURCES

⑪ Dec 1978

⑨ Final Report, 1 March 1977 - 3 July 1978

⑫ 123 P.

F

Approved for public release; distribution unlimited.

⑮ 33615-77-C-0040

⑩ 1121 ⑰ 03

LABORATORY

032 170

AIR FORCE SYSTEMS COMMAND

BROOKS AIR FORCE BASE, TEXAS 78235

79 01 24 035

NOTICE

When U.S. Government drawings, specifications, or other data are used for any purpose other than a definitely related Government procurement operation, the Government thereby incurs no responsibility nor any obligation whatsoever, and the fact that the Government may have formulated, furnished, or in any way supplied the said drawings, specifications, or other data is not to be regarded by implication or otherwise, as in any manner licensing the holder or any other person or corporation, or conveying any rights or permission to manufacture, use, or sell any patented invention that may in any way be related thereto.

This final report was submitted by Applied Science Associates, Inc., Box 158, Valencia, Pennsylvania 16059, under contract F33615-77-C-0040, project 1121, with Technical Training Division, Air Force Human Resources Laboratory (AFSC), Lowry Air Force Base, Colorado 80230. Mr. Brian Dallman was the contract monitor.

This report has been reviewed and cleared for open publication and/or public release by the appropriate Office of Information (OI) in accordance with AFR 190-17 and DoDD 5230.9. There is no objection to unlimited distribution of this report to the public at large, or by DDC to the National Technical Information Service (NTIS).

This technical report has been reviewed and is approved for publication.

MARTY R. ROCKWAY, Technical Director
Technical Training Division

RONALD W. TERRY, Colonel, USAF
Commander

Unclassified

SECURITY CLASSIFICATION OF THIS PAGE (When Data Entered)

REPORT DOCUMENTATION PAGE		READ INSTRUCTIONS BEFORE COMPLETING FORM
1. REPORT NUMBER AFHRL-TR-78-47	2. GOVT ACCESSION NO.	3. RECIPIENT'S CATALOG NUMBER
4. TITLE (and Subtitle) Measuring Troubleshooting Skills Using Hardware-Free Simulation	5. TYPE OF REPORT & PERIOD COVERED Final 1 March 1977 - 3 July 1978	
7. AUTHOR(s) William J. Mallory Thomas K. Elliott	6. PERFORMING ORG. REPORT NUMBER	
9. PERFORMING ORGANIZATION NAME AND ADDRESS Applied Science Associates, Inc. Box 158, Valencia, Pennsylvania 16059	8. CONTRACT OR GRANT NUMBER(s) F33615-77-C-0040	
11. CONTROLLING OFFICE NAME AND ADDRESS Hq. Air Force Human Resources Laboratory (AFSC) Brooks Air Force Base, Texas 78235	10. PROGRAM ELEMENT, PROJECT, TASK AREA & WORK UNIT NUMBERS 62205F 1121-03-14	
14. MONITORING AGENCY NAME & ADDRESS (if different from Controlling Office) Technical Training Division Air Force Human Resources Laboratory Lowry Air Force Base, Colorado 80230	12. REPORT DATE December 1978	
	13. NUMBER OF PAGES 122	
	15. SECURITY CLASS. (of this report) Unclassified	
	15a. DECLASSIFICATION/DOWNGRADING SCHEDULE	
16. DISTRIBUTION STATEMENT (of this Report) Approved for public release, distribution unlimited		
17. DISTRIBUTION STATEMENT (of the abstract entered in Block 20, if different from Report)		
18. SUPPLEMENTARY NOTES		
19. KEY WORDS (Continue on reverse side if necessary and identify by block number)		
Simulation Job Sample Test Symbolic Performance Test Criterion Referenced Test Electronics Maintenance	Electronics Troubleshooting Psychology Job-Oriented Training Measurement and Evaluation Measurement and Electronics Training	Measurement and Maintenance Training Measurement and Technical Training Vocational Education
20. ABSTRACT (Continue on reverse side if necessary and identify by block number)		
<p>Increased emphasis on performance-oriented training in the Air Force has created a need for more valid and reliable feed back on task performance. Traditional multiple-choice tests, while reliable and easy to administer, when related to job entry performance may not possess an acceptable level of validity. The use of actual equipment for job performance testing is expensive from the investment point of view, as well as costly in terms of test administration time and its general low availability to individual students. A possible alternative is a Symbolic Performance Test (SPT). Earlier attempted SPTs have generally been part-task analogues. Performance on these earlier tests has been dissimilar to actual troubleshooting performance.</p>		

D D C
RECEIVED
 JAN 31 1979
RECEIVED
 B

Unclassified

SECURITY CLASSIFICATION OF THIS PAGE (When Data Entered)

79 01 24 035

Block 20 (Continued)

The study began with a review of past SPT efforts to determine what was done and to evaluate the strengths and weaknesses of each approach. The troubleshooting task was then analyzed to determine discrete behavioral steps and the information requirements associated with each step. The SPT concept was developed around the results of these analyses.

With the SPT concepts firmed up, the presentation mechanisms (i.e., visuals and data tables) were designed. This design dictated the parameters of SPT materials to be produced. As earlier SPT researchers have observed, providing complete operating information in symbolic form can fill volumes and require extensive production time. Equipment materials were produced once for normal equipment operation. Problem-specific information was produced only for the subset of materials affected by an individual item. Clerical production was accomplished similarly using magnetic storage for normal data and inputting only the problem-specific changes.

The SPT materials were validated prior to the full-scale data collection. The validation revealed a major problem with the answering scheme and several minor problems with the visuals. Validation personnel commented on the difficulty associated with initially learning the SPT concept and materials use. The overall concept appeared workable and the individual results matched expectations. The answering scheme and the visuals were modified. As a result of the validation, a practice problem was also developed to provide free practice prior to a subject's symbolic performance testing.

The field testing was conducted at Lowry Air Force Base, Colorado, from mid-January to mid-February 1978. Fifteen students and 16 administrators were tested in groups of four for two days each. One test administrator monitored two sets of concurrent Job Sample Tests (JSTs) and SPTs. Data collected included: answer (suspected malfunctioning stage), time to completion, steps to completion, and a record of check sequence and location.

Analysis of the results indicated similar performance on both JST and SPT forms. The accuracy scores for all subjects on all tests produced a positive correlation of .384 which is significant at the .025 level.

Time to completion produced a positive correlation of .588 which was significant at the .0005 level. Steps to completion produced a positive correlation of .356 which was significant at the .025 level.

Analysis of the check sequences and locations produced very high positive correlations between performance on JST and SPT forms.

The primary difficulty encountered was highly variable troubleshooting performance regardless of test form. This variability is illustrated by the fact that the subjects on the average missed two problems out of every three. In this regard, results were similar to those of earlier studies.

The results indicate that the SPT approach was sound, requiring very few modifications. Several new applications are suggested by the results; these include:

- (1) Adapting the method for computer presentation,
- (2) Using the method to provide practice in training, in addition to testing,
- (3) Using some of the SPT equipment analyses for maintenance evaluation and in curriculum development. *cancel*
- (4) Applying the method to SPTs for other levels of troubleshooting penetration.

PREFACE

This document reflects the Air Force commitment to improve the quality and at the same time reduce the cost of technical training. This project was performed for the Air Force Human Resources Laboratory, Air Force Systems Command, United States Air Force, Brooks Air Force Base, Texas. The work described herein was performed by Applied Science Associates, Inc., Valencia, Pennsylvania, under Contract Number F33615-77-C-0040. Mr. Thomas K. Elliott was the Principal Investigator. Mr. William J. Mallory was the Project Director.

This work was performed under Project Number 1i21. Dr. Joseph Y. Yasutake was the Task Scientist. Dr. R. W. Spangenberg, Captain D. Harris, and Mr. Brian Dallman of the Technical Training Division, Lowry Air Force Base, shared Contract Monitorship. Dr. Marty R. Rockway was the Project Scientist.

The authors wish to acknowledge the cooperation and assistance of the individuals who contributed to this effort. Mr. Dennis L. Scott and Mr. Michael West of Applied Science Associates expended a great deal of precise effort in producing the symbolic materials.

Data collection at the 3450th Technical Training Group/TTMYM, Lowry Technical Training Center, Lowry Air Force Base, Colorado, went smoothly through the efforts of Mr. Michael J. Regan, Training Specialist, and MSgt. John Uhas, Course Supervisor.

ACCESSION FOR	
NTIS	Section <input checked="" type="checkbox"/>
DOC	Section <input type="checkbox"/>
UNCLAS	<input type="checkbox"/>
BY	
DISPATCH SYMBOLIC CODES	
Dist.	end of SPECIAL
A	

TABLE OF CONTENTS

	<u>Page</u>
INTRODUCTION	7
Background.	7
Objectives.	9
Troubleshooting	10
Summary of Approach	11
Test Development and Simulation Issues.	11
 METHODS.	 15
Criterion Development	15
Test Development.	28
Test Administration	41
 RESULTS.	 47
Introduction.	47
Summary Output Results.	47
Factors Affecting the Summary Accuracy Correlation.	50
Factors Affecting the Summary Time Correlation.	54
Presentation Order Effects.	54
Protocol Data	58
Problem Difficulty.	61
 CONCLUSIONS.	 62
Introduction.	62
Accuracy.	63
Time Correlations	63
Problem Difficulty.	64
Similarity of Performance	65
SPT Content Validity.	66
Discussion.	68

TABLE OF CONTENTS (Continued)

	<u>Page</u>
SUGGESTIONS FOR FUTURE RESEARCH.	69
Introduction.	69
Validity and Reliability Study.	69
Computer Presented SPT.	69
SPT Troubleshooting Practice Compared with Conventional On-Equipment Troubleshooting Practice.	70
Problem Difficulty Algorithm.	70
SPT Method Applicability to Other Levels of Troubleshooting.	71
REFERENCES	72
APPENDIX A. SPT SAMPLE PROBLEMS	75
APPENDIX B. ACCURACY RAW DATA	112
APPENDIX C. TIME TO COMPLETION RAW DATA	115
APPENDIX D. STEPS TO COMPLETION RAW DATA.	118

LIST OF ILLUSTRATIONS

<u>Figure</u>		<u>Page</u>
1	System-Level Block Diagram	16
2	Schematic Partitioned into Stages.	17
3	Equipment Breakdown by Troubleshooting Difficulty Matrix.	20
4	Data Flow Drawing with Optimal Solution Check Numbers Indicated	23

LIST OF ILLUSTRATIONS (Continued)

<u>Figure</u>		<u>Page</u>
5	Data Flow Drawing with Optimal Solution and Necessary Test Equipment Indicated	23
6	Problem Difficulty Algorithms (Keyed to Discussion). . .	25
7	Sequence of Test Materials Use	34
8	Point of Test Locator.	35
9	Point of Test/System State Conversion Table.	35
10	Voltmeter Conversion Table: AC.	36
11	Voltmeter Conversion Table: Ohms.	37
12	VOM Displays	38
13	Scope Displays	38
14	Problem Assignment Sheet	43
15	Test Site Floor Plan	44
16	Answer Card.	45
17	Sample Protocol Form	46
18	Accuracy Grand Means	48
19	Time to Completion Grand Means	49
20	Steps to Completion Grand Means.	50
21	Accuracy Grand Means for Students and Instructors. . . .	51
22	Accuracy Grand Means for Scope and Oscillator.	52
23	Oscillator Accuracy Means for Students and Instructors.	52
24	Scope Accuracy Means for Students and Instructors. . . .	53
25	Presentation Order Effects on Accuracy	55

LIST OF ILLUSTRATIONS (Continued)

<u>Figure</u>		<u>Page</u>
26	Presentation Order Effects on Time to Completion.	56
27	Presentation Order Effects on Steps to Completion.	58
28	Protocol Map	59

LIST OF TABLES

<u>Table</u>		<u>Page</u>
1	Comparison of Accuracy Metrics	63
2	Hypothesized and Empirical Item Difficulties	64
3	Comparison of Concordant Accuracy Results.	65
4	Comparison of Output Measures by Treatment Type.	65

INTRODUCTION

Increased emphasis on performance-oriented training requires the development of more job-relevant, valid, and performance-oriented approaches to skill measurement than the multiple-choice questions now in vogue in Air Force maintenance courses. One obvious alternative approach would be to give actual job sample tests using actual equipment. Such job sample or job task performance tests can provide high levels of content and face validity. However, these tests often require prohibitive amounts of test administrator time and may require scarce, fragile, and expensive prime equipment and test equipment. In addition, such tests are sometimes hazardous for both students and equipment. For these reasons, job-oriented testing on operating equipment has not been used or, at best, has been used in such a limited way that test results have been neither valid nor reliable. Resources are not now available to increase on-equipment testing nor are such resources likely to be available in the future. A reasonable solution may be found using a paper-and-pencil or computer-based simulation approach, which reduces test administrator burdens and does not require testees to perform on tactically configured hardware and to use scarce tools and test equipment. Simulated performance tests are strongly commended by AFM 50-2 as an approach for operating within training resource and safety constraints.

Background

Foley (1974) prepared an extensive literature review concerning the evaluation of maintenance performance. He cited several studies which showed, without exception, low correlations between job task performance tests and conventional pencil-and-paper theory and knowledge tests. Similar results were found by Engel and Rehder (1970) who concluded, for the specific Military Occupational Specialty examined, that the methods of evaluation in use (i.e., multiple-choice, job knowledge tests) did not possess an acceptable level of validity within a group or by individual measurement to support the existing personnel system requirements. Their conclusion could probably be generalized to any career area using conventional pencil-and-paper theory and knowledge tests for evaluation.

Bergman and Siegel (1972) reviewed the literature concerning training evaluation and student achievement measurement. They concluded that (1) there was too much use of rational rather than empirical methods; (2) there was too much subjectivity when objectivity was needed; and

(3) evaluation research was too often limited by monetary considerations. They also stated that most of the research studies reviewed were technically deficient because of (1) the use of too few subjects; (2) the use of inappropriate statistical techniques; (3) the failure to use control groups, or use of inadequate controls; (4) the use of improper sampling procedures; or (5) the use of inappropriate, contaminated or unreliable criteria.

Requirements for criterion-referenced job task performance tests were strongly emphasized by Foley (1974). Engel (1970) commended the work sample criterion as a reliable and job-relevant measure that also could be used as a standard for the evaluation of other measurement techniques. Advantages of job sample (job task performance tests) cited by Siegel, Bergman, Federman and Sellman (1972) were (1) realism; (2) practicality; (3) objectivity; (4) content validity; and (5) freedom from verbal requirements. Guidance in the preparation of these performance tests (at varying levels of usefulness) is contained in Boyd and Shimberg (1971) and Vineberg, Taylor, Young, Hirshfeld and Maier (1976). High cost and difficulty of administration of job task performance tests are widely noted (Engel & Rehder, 1970; Foley, 1974; Foley, 1975; Osborn, 1970; Siegel et al., 1972). Osborn (1970), using the term "synthetic performance tests," recommended selection of inexpensive alternatives to fully job-relevant performance tests. Cost trade-offs should be made. Foley (1974, 1975) quite explicitly demanded empirical validity, stating that job task performance tests should be used in spite of their high cost, if they are the only empirically valid tests available.

Fitzpatrick and Morrison (1971) cited two symbolic performance tests as tests of diagnostic problem-solving performance: the Tab Test for troubleshooting (Glaser, Damrin, & Gardner, 1952), and the medical simulation exercises of McGuire and Babbott (1967).

Foley (1974) discussed empirical validity of early pencil-and-paper substitutes for job task performance tests. Of particular note were the symbolic equipment tests as represented by the Tab Test (Crowder, Morrison & Demaree, 1954) and the Multiple-Alternative Symbolic Troubleshooting Test (MAST) (Grings, Rigney, Bond & Summers, 1953). These tests displayed equipment schematic diagrams. Tabs were used to cover displays of information normally obtained by using test equipment on the actual hardware. Corks were substituted for tabs in the MAST. Correlations with job task performance tests were found to be minimal in studies by Crowder et al. (1954) and Evans and Smith (1953).

Foley (1974) expressed the strong opinion that a different approach to the development of symbolic performance tests could result in higher correlations. However, the results in an initial attempt to provide better symbolic performances in the area of troubleshooting showed a negative correlation with job task performance tests (Shriver & Foley, 1974). Initial validation of symbolic troubleshooting was deemed unsuccessful. Following modification, Shriver and Foley (1974) then found symbolic tests

to have a high degree of empirical validity (when using job task performance tests) at the chassis or black box level (although not when higher numbers of alternatives were possible, as at the component or piece-part level).

Several considerations and hypotheses were presented to influence future development of symbolic performance tests. Of particular note were the suspected inability of many subjects to use test equipment properly, the distractions and interruptions typically found on the job, and the need for inclusion of a more realistic presentation of information (including the use of random-access projection of test equipment readings). In support of the final consideration, Lefkowitz (1955) showed realism to be an important factor in the validity of pictorial tests (although there was a practical limit).

Written simulation, a technique simulating the decision-making processes of doctors and others involved in diagnosing and managing patient problems, has been widely used in the health professions for testing and certification. McGuire, Solomon, and Bashook (1976) suggested that the essence of simulation could be captured in a pencil-and-paper format employing either latent image or opaque overlay techniques for feedback systems. Thus, written simulations have been claimed to provide economic and technical feasibility for self-assessment and large-scale testing in varied settings. McGuire et al. (1976) asserted that the methodology of written simulation is widely applicable to an almost unlimited variety of content areas, educational levels, and management settings. The technique, however, has not been successfully applied to troubleshooting in an Air Force environment. Similar techniques, however, have been used for training (Cantor & Brown, 1956; Naval Training Device Center, 1960).

Objectives

The aim of this effort was to develop and evaluate the practical usefulness of a paper-and-pencil simulation approach to performance testing in a technical training environment. It was expected that the approach could be generalized to a broad range of testing situations. The focus of the effort was on corrective maintenance of electronic equipment--a pervasive maintenance problem common to a wide variety of Air Force Specialty Codes (AFSCs). More specifically, the effort focused on the measurement of electronic troubleshooting skill--widely seen as the most critical skill underlying overall electronic maintenance performance and a skill which has been studied extensively by behavioral scientists for over three decades.

Troubleshooting

Troubleshooting is viewed within this study as a systematic process for gathering information about external and internal malfunction symptoms, leading through the functional dependency relations (data flow) among equipment components to a deduced conclusion as to the component causing the externally observed symptom. The process is characterized by dependency relation analysis (information gathering using test equipment) and sequential decision making (i.e., deciding what information to collect and ultimately what component to adjust or replace).

The activities inherent to the process are described below, in the usual order.

<u>Activity</u>	<u>Process</u>
1. Symptom Detection	The failure of the equipment to perform to specification is noted. Initiating cues include write-up, scheduled check, or operational failure.
2. Symptom Pattern Completion	When equipment malfunctions, some number of equipment outputs will be affected. The logic of troubleshooting first checks which outputs are bad and then looks for a cause which is common to all the bad outputs. Much internal checking can be avoided by noting which outputs are good and bad.
3. Symptom Pattern Analysis	With a complete symptom pattern, stages not associated with bad outputs can be eliminated without internal checking.
4. Output Deficiency Analysis	In some cases, the character of the symptom itself, rather than its relation to other symptoms, focuses on particular groups of stages as the only ones which can cause that sort of symptom.
5. Specific Experience	(A special case of Activity 4.) This sort of knowledge is usually associated with long experience with the equipment during which the technician learns to associate probable causes with specific output conditions.

Summary of Approach

Briefly, the approach was to develop an equipment-free, paper-based simulation of the hardware which the testee could troubleshoot in the same logical manner as he would troubleshoot the real hardware, thus requiring similar knowledges and cognitive skills. In this case, the hardware consisted of the HP 652A oscillator and the Tektronix 453A oscilloscope, commonly used by Air Force technicians. It was expected that troubleshooting task performance on the simulation would be predictive of performance of the same tasks on the actual hardware. To test this assumption, two groups of subjects--journeyman technicians represented by instructors in the Precision Measuring Equipment (PME) course at Lowry Air Force Base, Colorado, and novices represented by students in the same course (who had completed training on this equipment)--were given the same problems in two test modes: criterion or Job Sample Test (JST) and simulation or Symbolic Performance Test (SPT). There were 15 students and 16 instructors who were given three problems on each piece of equipment in each mode--3 x 2 x 2 or 12 problems in all.

Test Development and Simulation Issues

The Criterion Problem

It is important to recognize that criterion validity is not assured through use of actual job tasks as test items. Whether such tasks are used or not, it is necessary that the variety of tasks be sufficient to account for the variability in the hypothetical ultimate criterion and that the test tasks be performed under conditions similar to those found on the job. Further, if validity is to be assured, the scoring of individual items must reflect their importance in the context of the total job or task.

It is possible that a performance test with all of the above characteristics (which would make its contents valid) could be entirely useless because of unreliability. Thorndike (1949) notes that it is not necessary for the reliability of a criterion measure to be extremely high. It is necessary that the criterion measure's reliability be other than zero, and that the reliability be known, since if it is not, validation of other instruments against the criterion will not be possible.

Even if the criterion test produces valid and reliable measures of performance, it may still fail in usefulness because it is not diagnostic. If the criterion measures will be used to validate instruments which will predict only success or failure on the job, and if success or failure truly expresses the limit of our interest, then such a criterion would be useful. However, such a criterion would not be useful if we

were interested in knowing why those who failed did so, what specific tasks proved too difficult for them, or what training or performance aids would be required to bring them to an acceptable level of competence. It is questions of this latter sort in which we are most often interested.

Simulation

If all important behavioral components of a task are represented in the simulation in about the same way they are represented in the real world, performance in the two situations should be similar. To achieve good simulation (i.e., good behavioral verisimilitude), the opportunities for error or inadequate performance which would degrade performance in the real world must be found to about the same extent in the simulation. Note that nothing has been said about physical resemblance. The focus must be on the behavioral components of tasks. In general, money spent on simulation for reasons other than to create an opportunity to exhibit the behaviors critical to task performance must be justified on grounds other than fidelity of simulation.

Good simulation must be based on careful analysis of the tasks for which simulation is desired. Just as too much attention to physical resemblance may not be cost effective, too little attention to behavioral similarity can lead to simulations which are of little value in predicting real-world performance.

Previous work in troubleshooting task simulation has been plagued by several difficulties. Chief among them is that tasks have been modified for simulation purposes in such a way as to make them different (usually easier) than the tasks performed on the hardware.

Some previous efforts have restricted the range of troubleshooting behavior sampled in the JST to what was possible to simulate with a given technique. While this will lead to better prediction of success on the JST from knowledge of performance on the SPT, the generality of the result is limited by the partial JST behavior sample.

Systematic efforts have rarely been made to establish the content validity of the JST, and no study has been found which has, for electronic troubleshooting, empirically related performance on the JST to overall job performance. Further, it has often been impossible because of resource limitations to develop sufficient numbers of items to assure measurement reliability, either on the JST or SPT. Additionally, SPTs have frequently failed to predict performance on JSTs because the behavior sample domains of the two tests were different, typically in that many behaviors required on the JST were not required on the SPT. Outstanding examples of such omissions are use of test equipment and translation of data-flow representations, such as schematics, to physical representations of the hardware.

Troubleshooting is often a higher order task with many components. Skill on one or some of the components may not always predict whole-task skill. Absence of some critical skill elements (use of test equipment is an excellent example) can be completely disqualifying, and skill in all components does not assure whole-task competence.

For some technicians, "making it all play together" is a significant problem. Keeping track of where one is in the deductive process--what is known and what still must be found out--while continually being interrupted with interpolated tasks, such as getting access to test points and setting up test equipment, adds an important dimension to task difficulty.

Three other important difficulties with troubleshooting simulations follow:

1. Error cues have been provided in the SPT which would not be present in the JST. This has resulted often from the difficulty of providing equal error opportunity in the SPT. To do so implies providing information on test points not ordinarily considered relevant to the problem being solved. Information on non-relevant test points has frequently presented cues to the testee indicating that he was on a non-relevant test point and cuing him to alter his strategy.
2. The SPT by its very nature fosters the use of a different approach to troubleshooting by the technician in that all tests tend to be of equal effort, whereas in the JST there is often wide variance in the effort required to make a test. The tendency of technicians is to maximize information gained per unit check cost where the cost of the check is in terms of the difficulty of gaining access to the test point, waiting for the system to cycle into the right state, hooking up additional test equipment, using test equipment with which he is unfamiliar, etc. This means that he tends to make cheaper rather than more expensive checks when troubleshooting real hardware. Check costs tend to be equal in the SPT mode, and thus check cost is not a variable.
3. Simulations have tended to assume that the system was always in the appropriate state making it unnecessary for the testee to be concerned about system state and, indeed, considerably reducing his opportunity for error (system state equals a unique set of positions for switches, including internally controlled switches).

The following section covers how the JST (criterion) and SPT (simulation) were developed and how the testing was conducted in this effort. Results and conclusions will be found following the methods discussion.

METHODS

Criterion Development

Criterion development took the general form of identifying potential malfunction problems in each piece of equipment and then assessing the representativeness of each possible problem as well as assessing the practical difficulty in isolating the cause of a malfunction.

During the pre-item selection and equipment analysis, the equipment was studied and the schematic diagrams were partitioned at the stage level. The relative difficulty of locating any given stage as the cause of a malfunction was assessed. The difficulty factor was then used to group possible items into three classes ranging from hard to easy to locate problems.

Item selection and validation were based on the expertise of PMEL instructors with field experience on the equipment to be used in the test. Their selections were made after an analysis of the equipment and examination of the assigned difficulty ranking.

Once a consensus was reached on which items to use, failed components within the stage and failure modes (e.g., open, short, change in value) were specified. A major concern was the design of malfunctions that were not visually detectable.

Pre-Item Selection/Equipment Analysis

The desired level of penetration was to the stage level. The first task, therefore, was to divide the equipment into stages. Selection of stages was accomplished by looking first at the system-level block diagram, as shown in the vendor-supplied maintenance manual. Selection was made to correspond as closely as possible to the individual blocks on the system-level block diagram in the maintenance manual. Choice of stages was indicated by drawing partitioning lines on the schematics. Figure 1 is a system-level block diagram, and Figure 2 is a schematic of part of the equipment with the stage lines shown. The following definition was used as a guide in determining stages:

A stage is generally considered to be one step in a multi-step process. An amplifier stage might be a single transistor or integrated circuit and its associated components, such as resistors and capacitors, while an oscillator or multivibrator stage may contain two or three transistors and their associated components.

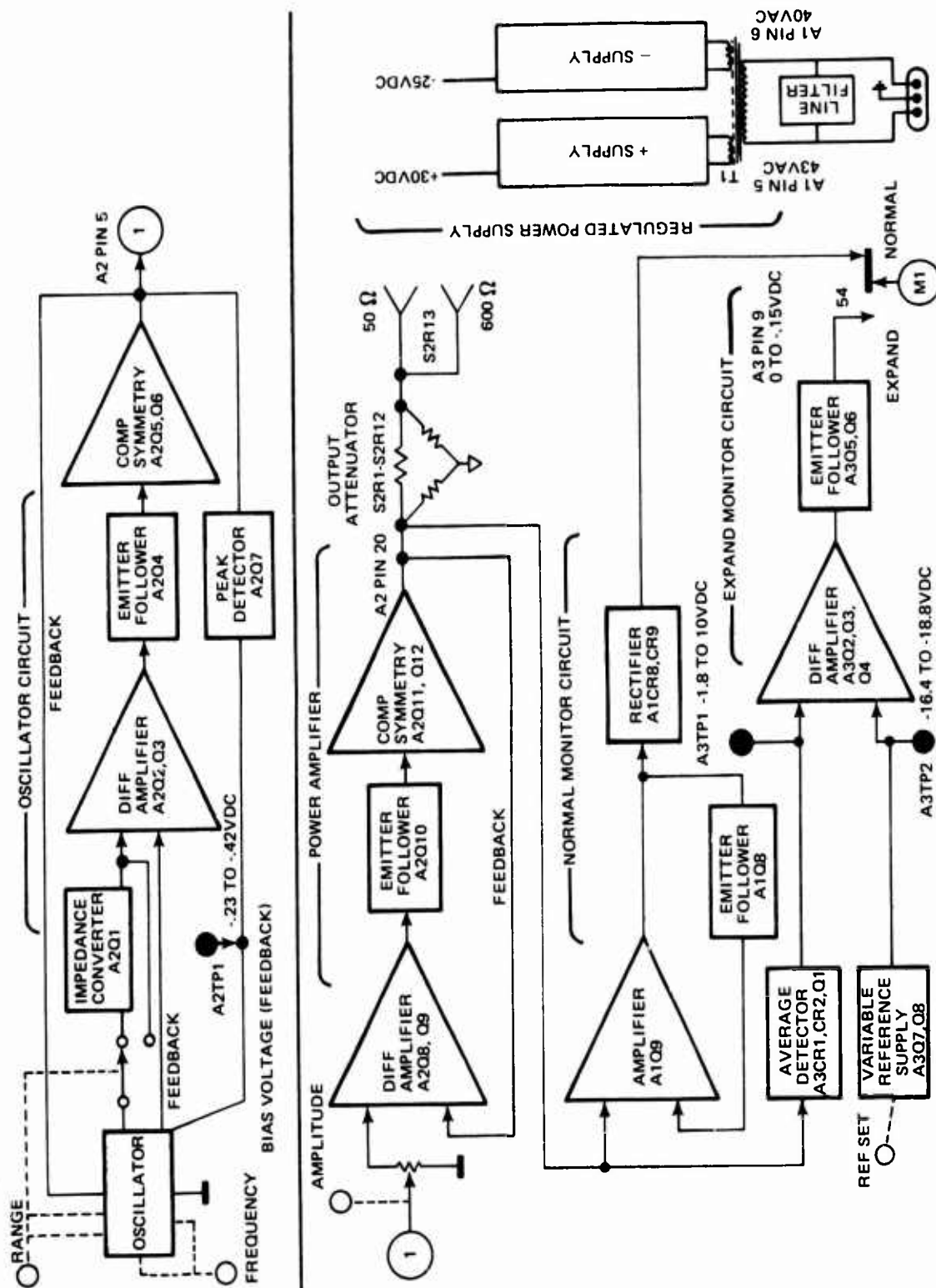

Figure 1. System-Level Block Diagram

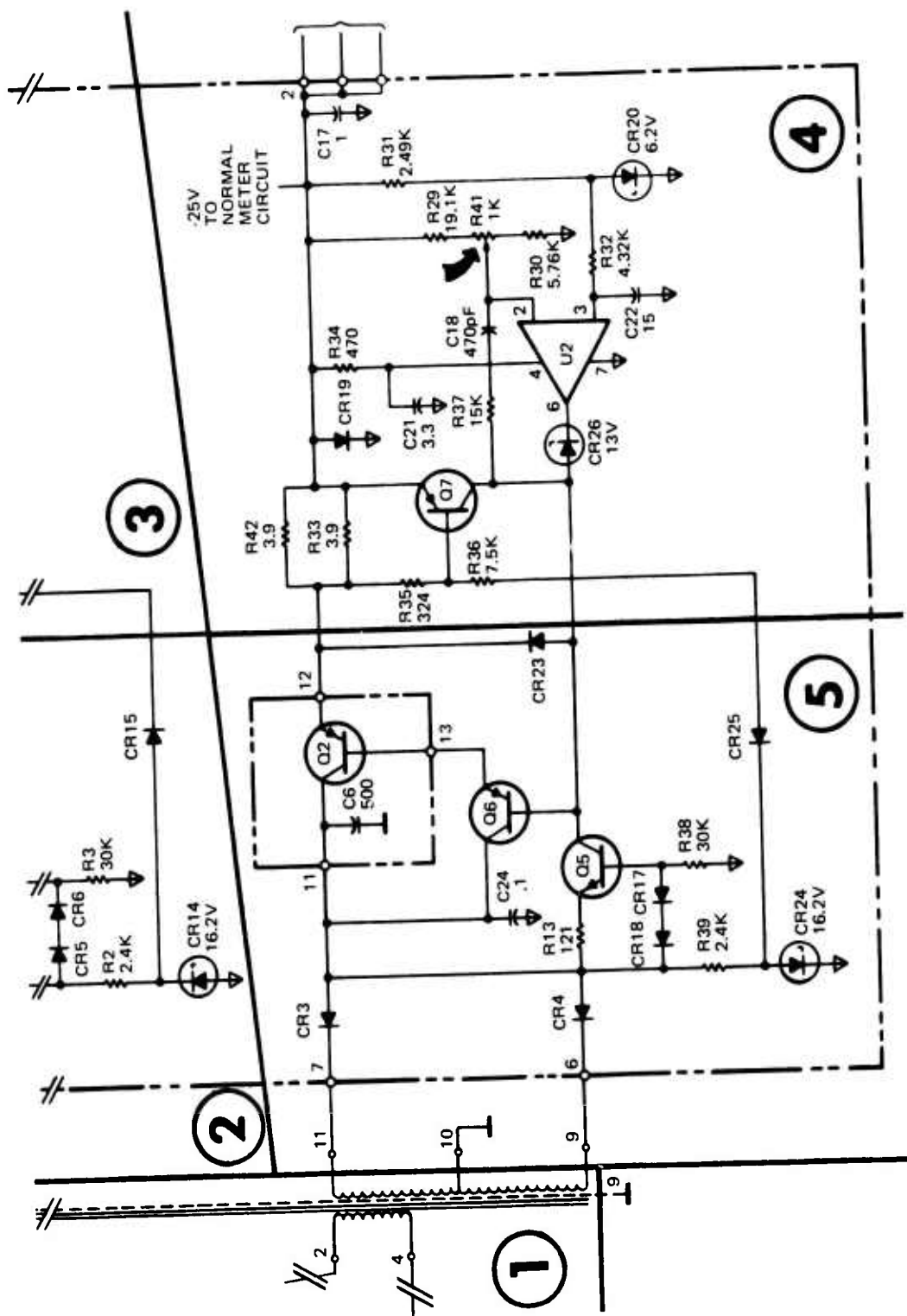

Figure 2. Schematic Partitioned into Stages

Test Item Selection Criteria Development

The project was concerned with the information-gathering and sequential decision-making elements of troubleshooting. The behaviors of concern were the following:

1. Deciding where in the data flow to test.
2. Selecting the test instrument and test parameter.
3. Identifying the physical test point in the hardware.
4. Reading the test result.
5. Deciding whether the outcome is good or bad.

In stage level troubleshooting, this group of behaviors is repeated for the sequence of points of test selected by the testee until the stage containing the malfunction is identified. At the behavioral level, there should be no difference between the JST and the SPT. The objective in developing these selection criteria was to characterize the population of problems on the equipment so that those of known difficulty could be selected.

Previous research has shown that troubleshooting difficulty is a function of:

1. The complexity of the data flow, where complexity is equal to the number of components plus the number of interconnections among them.
2. The kind and amount of test equipment ordinarily available for use in checking.
3. The information available in the performance aids on readings and tolerances.
4. The information available in the performance aids and/or placarded on the hardware concerning test point locations.
5. The data flow presentation itself. (Some data flow presentations greatly facilitate deciding where in a system to check because of their layout. Indeed, some presentations are supplemented by symptom cause charts or dependency charts which also aid in deciding where to check.)

Another criterion to be considered was failure frequency. Frequency of failures in most electronic equipment is heavily skewed, with a relatively small percentage of components accounting for a relatively large

percentage of failures. This fact must be taken into consideration in selecting test items if they are to be truly representative of the normal troubleshooting fault population.

Equipment Breakdown by Troubleshooting Difficulty. A matrix was designed to characterize relative problem difficulty. Refer to Figure 3 for an illustration of the matrix format. The rows of the matrix represent the stages. The matrix columns list factors which affect troubleshooting difficulty, including:

1. Type of data flow representation in the maintenance manual.
2. A listing of test equipment required for troubleshooting.
3. Type and amount of reading and tolerance information available in the performance aids for each parameter appropriate to the test instrument in question (e.g., for a voltmeter, readings and tolerances may be available for voltages, but not for current or resistance; or readings and tolerances may be available for waveforms, but not RMS values measured on a voltmeter. This is usually a function of the maintenance manual for a particular piece of equipment).
4. The number of stages and interconnections among them within the functional group.
5. Failure frequency.

The matrix permits identification of problems representative of all required behaviors (such as scope display interpretation, meter reading, deciding where to check next in the absence of normal reading, and information in the performance aid) and will reflect those problems most often encountered in actual maintenance. The following paragraphs discuss the contents of each matrix column.

Equipment Breakdown--A listing of stage designations for the equipment being analyzed. The stage designations consisted of the reference designator for the active circuit component in a stage, such as Q11 for a transistor or CR4 for a diode.

Failure Rate--An indication of high, normal, or low failure rate determined by analyzing logistics failure rate data. On this effort, these entries were supplied by field experts during the problem validation.

Complexity (Number of Connections)--The total number of interconnections among the components within a particular stage.

EQUIPMENT BREAKDOWN	DIFFICULTY DIMENSIONS	FAILURE RATE	(HI, LO, Avg)	COMPLEXITY (# of	Connections)	POINT OF TEST	ACCESSIBILITY	(Hard, Easy)	SCHEMATICS	(Yes, No)	SYMPTOM CAUSE	(Yes, No)	TRUBLESHOOTING	TREES (Yes, No)	PARTS/PT. OF TEST	LOCATION (Yes, No)	CIRCUIT DESCRIP-	TIONS (Yes, No)	OPTIMAL SOLUTION CHARACTERISTICS	# OF TROUBLESHOOT-	ING STEPS	# OF STEPS	NO VALUES	# OF INPUT & POWER	SUPPLY STEPS	# OF STEPS USING	SCOPE	# OF STEPS USING	VOM	# OF STEPS USING	# OF STEPS USING	# OF STEPS USING	# OF STEPS USING	PROBLEM	DIFFICULTY	

Figure 3. Equipment Breakdown by Troubleshooting Difficulty Matrix

Point of Test Accessibility (Hard or Easy)--An assessment of ease of access. Accessibility was judged "Easy" if components were located on the top of printed circuit boards and had reference designators nearby making points of test easy to find. Accessibility was judged "Hard" if a second layer of protective covers had to be removed to provide access to points of test, or if the stages in question had feedback loops connected to them which ordinarily would be broken in troubleshooting. If the stages had feedback loops which were not available on connectors or terminals (indicating that a component would have to be desoldered or a foil strip broken to break the feedback loop in order to inject synthetic feedback), accessibility was also rated "Hard."

The "Documentation Features" portion of the matrix covered the maintenance manuals made available to the troubleshooter on the test equipment specified. This part of the matrix was comprised of the following five categories.

Schematic Coverage--If the stage had schematic diagram coverage to the component level, a "Yes" was indicated. If not, a "No" was indicated.

Symptom Cause Coverage--If the documentation contained a Symptom Cause Chart operating at the desired level of maintenance, a "Yes" was indicated. If not, a "No" was indicated.

Troubleshooting Tree Coverage--If the documentation had troubleshooting trees to identify malfunctioning stages, a "Yes" was indicated. If not, a "No" was indicated.

Parts/Point of Test Location Coverage--If the maintenance documentation contained information in which individual component locations were specified, the column cell entry was a "Yes." If it did not, the cell entry was a "No."

Circuit Description Coverage--The circuit descriptions contained in the documentation were checked to see if they discussed individual stage operation. If the circuit descriptions contained only superficial mention of a stage and its function, the cell entry was a "No." If the stage and/or its function were discussed in sufficient detail (electron current flow), the cell entry was a "Yes."

The "Optimal Solution Characteristics" were derived by doing a paper-and-pencil troubleshooting exercise on each segment of the data flow that could be isolated as a cause of a single missing output from the device. A partial data flow drawing was constructed for the stages necessary to produce the missing output. Troubleshooting of the data flow diagram then consisted of half-splitting the data flow and recording the check

number at each point of test. In this case, checks upstream or downstream from an earlier check were given the same number at the next half-split point (see Figure 4).

For example, in a data flow diagram of eight series blocks, the first check would be between blocks 4 and 5 and would be labeled 1. The next upstream check would be between blocks 2 and 3 and would be labeled 2. The next downstream check would be between blocks 6 and 7 and would also be labeled 2. Troubleshooting of each data flow drawing was completely performed in this manner.

The test equipment required to measure signals at the designated points of test was also noted. The schematic diagram or other maintenance data were checked to see if readings, waveforms, or other relevant signal parameters were present. If the value was not present, "No Value" was indicated adjacent to the check number. For components with more than one input, it would not matter which input received the next check number, or the next check number plus one. Figure 5 shows an optimal solution including this type of information.

Number of Troubleshooting Steps--For the following explanation, refer to Figure 5. The number of troubleshooting steps was indicated by the highest check number recorded on any of the inputs to the stage, plus the number of checks associated with the stage, plus as many checks as were required to check all of the inputs to the particular data flow diagram. In the example illustrated by Figure 5, the number of troubleshooting steps is seven, including one for the power supplies, one for each of the inputs, and four, the highest check number on an input.

Number of Steps No Values--Total number of "No Value" steps ("No Value" steps are checks at points of test with signal values not provided by the maintenance documentation). Check 3 or 4 (the output of block 9) on Figure 5 is a "No Value" step.

Number of Input and Power Supply Steps--The number of input and power supply steps was the total of the power supply checks and the input checks required to verify correct power supply and signal inputs to the data flow diagram.

Number of Steps Using Scope--The number of checks made with the scope was recorded in this cell. Tests made on the power supply and the inputs with the scope were also included.

Number of Steps Using Volt-Ohm-Milliammeter (VOM)--The number of checks made with the VOM to isolate the problem was entered in this cell. Tests made on the power supply and the inputs were again included.

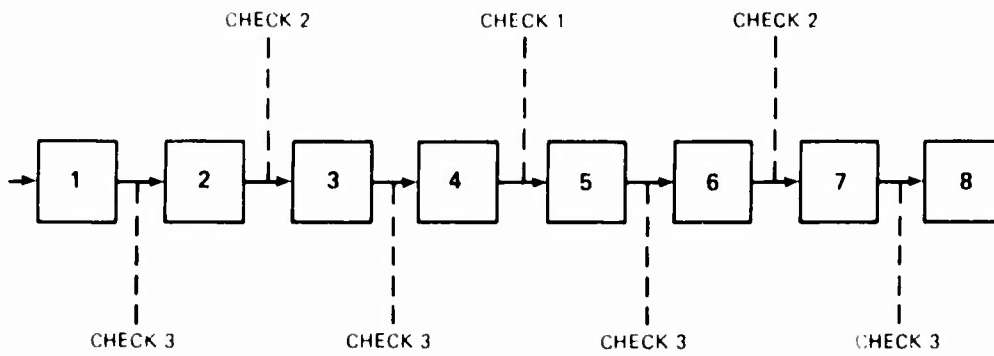

Figure 4. Data Flow Drawing with Optimal Solution Check Numbers Indicated

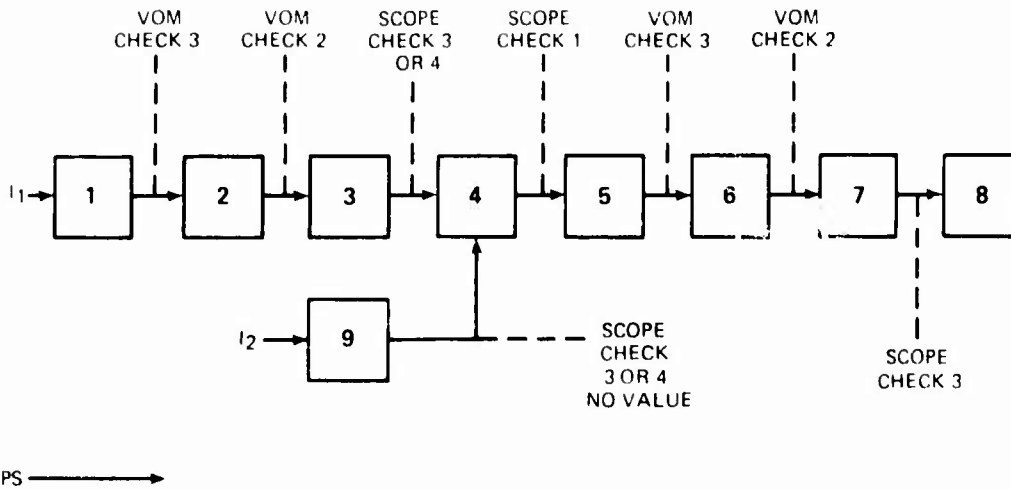

Figure 5. Data Flow Drawing with Optimal Solution and Necessary Test Equipment Indicated

Number of Steps Using--There was space provided in the matrix for several of these columns. These columns were provided in anticipation of the later discovery that additional test equipment was required to troubleshoot. Examples of other equipment might include signal generators, power supplies, and power meters. The cell entry would be the number of required checks made with the equipment during the optimal solution.

Problem Difficulty--Problem difficulty is a number ranging from zero to 100. The higher the number, the more difficult the problem, according to the algorithm. This number was computed and entered on the matrix after all other matrix cells were filled.

Problem Difficulty Algorithm. The problem difficulty algorithm had two forms: one with an accessibility factor and one without. After reviewing a completed matrix, if it was discovered that all of the accessibility entries were the same, the algorithm without the accessibility factor could be used, since accessibility was then a constant and would not change the results. Dropping accessibility makes the calculation of the individual difficulty numbers easier and faster.

Both forms of the algorithm contain weighting factors which were estimated by troubleshooting experts. These estimates were made by judging the relative importance of each algorithm factor to the troubleshooting task. The experts judged that test equipment use and hardware operating values were most important, of equal value, and account for 75 percent of troubleshooting difficulty. The remaining three factors were judged approximately equal in importance and assigned weights of 8.3 each to account for the final 25 percent. The algorithm weights of these were adjusted to 12.5 in the version which omits accessibility.

Both forms of the difficulty algorithm are shown in Figure 6. (Refer to this figure during the following discussion, to which it is keyed.)

1. The first term in the equation is a complexity factor, determined by taking the number of stage connections for a given stage and dividing it by the number of stage connections in the largest stage of the equipment. The result is then multiplied by a constant weighting factor of 8.3 in the algorithm version including the accessibility factor, or 12.5 in the algorithm version omitting the accessibility factor.
2. The second term in the equation is the accessibility factor (if it is required). Where there are differences in accessibility, the matrix entries are rated either

$$\begin{aligned}
 & \textcircled{1} \quad \left[\left(\frac{SC}{LSC} \right) (8.3) \right] + AF + \left[\left(TF - ATF \right) \left(\frac{8.3}{TF} \right) \right] + \left[\left(\frac{TSNV}{TS} \right) (37.5) \right] + \left\{ \left[\left(\frac{\Sigma TETU \times TED}{TS} \right) + \left(\frac{\Sigma TET + 1U \times TED}{TS} \right) + (ETC) \right] \right\} (12.5) \\
 & \textcircled{2} \quad \textcircled{3a} \quad \textcircled{3b} \quad \textcircled{4}
 \end{aligned}$$

ACCESSIBILITY FACTOR INCLUDED

$$\begin{aligned}
 & \textcircled{1} \quad \left[\left(\frac{SC}{LSC} \right) (12.5) \right] + \left[\left(TF - ATF \right) \left(\frac{12.5}{TF} \right) \right] + \left[\left(\frac{TSNV}{TS} \right) (37.5) \right] + \left\{ \left[\left(\frac{\Sigma TETU \times TED}{TS} \right) + \left(\frac{\Sigma TET + 1U \times TED}{TS} \right) + (ETC) \right] \right\} (12.5) \\
 & \textcircled{2} \quad \textcircled{3a} \quad \textcircled{3b} \quad \textcircled{4}
 \end{aligned}$$

ACCESSIBILITY FACTOR OMITTED

ABBREVIATIONS IN ORDER OF USE

- PD = Problem Difficulty
- SC = Stage Complexity
- LSC = Largest Stage Complexity
- AF = Accessibility Factor
- TF = Troubleshooting Features (All)
- ATF = Applicable Troubleshooting Features
- TSNV = Troubleshooting Steps No Values
- TS = Troubleshooting Steps (All)
- TETU = Test Equipment Times Used
- TED = Test Equipment Difficulty

Figure 6. Problem Difficulty Algorithms (Keyed to Discussion)

"Easy" or "Hard." In the formula, a "Hard" entry equals a constant of 8.3; an "Easy" equals zero. In the calculations here, each term in the algorithm reduces to a number which is summed with the numbers from the other terms to provide the difficulty factor; thus, "Hard" accessibility adds 8.3 to the total.

3. The third factor, divided into two parts, accounts for the amount of help, or its inverse, the lack of troubleshooting help supplied by the available documentation and critical decision information.
 - a. The first part deals with the number of available features in the documentation and the number of features that are applicable to troubleshooting a given stage. The number of applicable features for a given row is obtained by counting the cells with the "Yesses"; this number is then subtracted from the total number of features, obtained by counting the number of columns under "Documentation Features." The result of this subtraction is then multiplied by the result of dividing 8.3 by the total number of features.
 - b. The second part consists of dividing the number of troubleshooting steps with no values (obtained from that column in the matrix) by the total number of troubleshooting steps (obtained from its column), and multiplying the result by 37.5.
4. The fourth factor in the equation is a composite of subordinate equations, one for each piece of test equipment used in the optimal troubleshooting solution. Each factor consists of the total number of measurements performed with a given piece of test equipment, multiplied by the test equipment difficulty factor. That quantity is then divided by the total number of steps in the optimal solution. This operation is repeated for each piece of test equipment using the same process. The results are then summed and multiplied by a constant of 12.5. The test equipment difficulty factors used on this project were: 3 for an oscilloscope or signal generator, 2 for a power supply, and 1 for a VOM or a Digital Voltmeter (DVM).

Test Item Validation and Selection

The matrices were validated by five Air Force PMEL instructors, who evaluated information presented and noted any significant deviations from field practice. It was possible that test equipment specified in the

maintenance manuals was not typically available in the field or that test equipment commonly used in the field was not specified. In addition, the troubleshooting routines designed to present optimal solution to the problems might have failed in one way or another to take advantage of special procedures used in the field.

The validation consisted of the experts either agreeing or disagreeing with the difficulty assessment of the potential items. The test items were taken from the list of those candidate problems agreed to by all of the experts. At the conclusion of the validation, the problem characterization and the minimum inventory of test equipment required for troubleshooting were agreed upon.

Malfunction Design

One hard, one average, and one easy item were selected from the list of possible items for both pieces of equipment to be used in the test. At this point, each item was specified as a malfunctioning stage. It was then necessary to select a component to be failed and a failure mode. In selecting a failure mode, it was important to select one which would not cause additional damage to the equipment. Additional equipment damage would confuse the results, since there would be more than one problem to be solved in the equipment.

The malfunctions used in the test to be discussed here consisted of the following:

Tektronix 453A (Scope)

Q504 - open emitter/base junction - hard - DF* = 77.4
Q923 - open emitter/base junction - average - DF = 51.7
Q1255 - open emitter/base junction - easy - DF = 40.8

Hewlett-Packard 652A (Oscillator)

AIQ9 - shorted emitter/base junction - hard - DF = 64.7
AICR19 - shorted - easy** - DF = 47.8
A3Q6 - open emitter/base junction - easy - DF = 48.2

Malfunction installation techniques were considered from the standpoint of ease of installation and removal, and also from the standpoint of providing visual clues to the troubleshooter which might make malfunction isolation easier.

*DF = Difficulty Rating

**This item was originally selected as average, but upon reexamination was judged easy.

Test Development

Job Sample Test

The JST was designed to be a re-creation of the normal troubleshooting task and environment. Actual malfunctioning equipment was used. Normal test equipment and maintenance manuals were available for use in troubleshooting. The test administrator checked the equipment operation between items, installed the malfunctions, and gave the testee a terse write-up of the problem. The testee was free to pursue any strategy in locating the malfunction short of wholesale parts replacement.

The only additional or test-specific requirement was for the testee to fill out a protocol form during the troubleshooting. The testee noted the point of test and type of instrument used for each check made during fault isolation.

Symbolic Test

Previous research has not provided a highly reliable predictive symbolic substitute test for electronic troubleshooting. Some tests were conceived as part-task performance analogues.

In his Annual Review of Psychology article on "problem solving and thinking" in 1959, Gagne said, "To summarize, troubleshooting of complex equipment typically consists of problem solving which is sequential in nature; there is a sequence of hypotheses that must be tested in order to narrow progressively the area in which the malfunction is located." Earlier research developing and testing symbolic substitute tests dealt only with the abstract logic of problem solving in troubleshooting, such as the studies by Crowder, Morrison, and Demaree (1954) and by Evans and Smith (1953), each of which produced low correlations.

Shriver and Foley (1974) suggest that none of the earlier tests "included any of the 'distractions' from the main line of 'problem solving' found in the real world of troubleshooting. In the job environment an individual must, for example, set up and operate his test equipment to obtain test point information, as well as to obtain instructions and information from his Technical Orders." These distractions interrupt the analytic problem-solving thought process and contribute to the overall task difficulty. They also increase the opportunity for procedural and interpretive errors which may inappropriately modify the problem-solving strategy. It is very possible that troubleshooting difficulty is greater than the sum of the individual component behavior difficulties.

In a discussion of their revised symbolic troubleshooting test design, Shriver and Foley (1974) used:

1. Pictorial test equipment displays (meter faces and oscilloscope displays).
2. Procedural simulation (subject was not required to follow any particular strategy by test materials).
3. Integrated testing (test situation and materials required subject to interact with the usual materials and equipment--perform the normal behaviors symbolically--and to integrate the results to conclude the nature of the malfunction).
4. A component replacement option with associated display changes for replacing a defective component.
5. A test administrator for every subject.

The symbolic testing reported by Shriver and Foley (1974) covered fault isolation and three levels of penetration:

1. Major unit (black box)
2. Individual circuit (stage)
3. Component (piece-part)

At the major unit level, symbolic results matched criterion performance 87 percent of the time. At the individual circuit level, results matched 67 percent of the time, and results matched 53 percent of the time at the component level.

Shriver and Foley (1974) concluded that as the actual troubleshooting task required use of more test equipment to isolate malfunctions, instances of matching performance on symbolic and criterion tests dropped. They suggested that symbolic substitute tests for test equipment operation be used to screen potential subjects. While this approach would certainly produce a positive effect on the evaluative statistics, it does not deal directly with the issue of making the symbolic test more equivalent to the actual job, and thus more predictive of actual performance on the job.

It seems reasonable that a symbolic test permitting the exercise of all useful troubleshooting behaviors would be highly correlated with on-the-job performance.

Analysis of troubleshooting behavior suggested that the following subtasks be addressed by the symbolic test design:

1. Manipulating the equipment state (front panel control configuration) to discern the character or probable location of the malfunction.
2. Obtaining operating parameters from any point of test within the equipment (where point of test is any junction of two or more components).
3. Choosing any of the test instruments normally available for troubleshooting to measure static or dynamic operating parameters (via the troubleshooter's preferred approach).
4. Physically locating the desired point of test.
5. Specifying the desired test parameter.
6. Setting up and connecting the test instrument to obtain the desired measurement.
7. Reading displays and factoring range and function information to obtain measurement values.
8. Judging the test results (value is in or out of tolerance).
9. Repeating the above sequence until the faulty component can be specified.

The design described by Shriver and Foley (1974) covered three levels of troubleshooting, and the materials varied somewhat from level to level. When viewed separately, the stage level isolation test did not contain items 1, 2, 4, 6, or 7. Our hypothesis is that this test was less typical of the job than the black box level test and accounts for most of the excess variation between criterion and symbolic results in the stage level comparison.

Task analysis, item selection, validation, test equipment identification, and malfunction design combined to supply the information handling requirements of the SPT. The information to be provided by the SPT included the following:

1. Access to all possible electrical points of test.
2. Access to front panel controls to change system state.
3. Access to front panel displays.

4. Access to test equipment range and function controls.
5. Test equipment displays for all combinations of range, function, system state, and points of test.

The goal of the format design was to provide the easiest possible access to the information listed above in a cost-effective way. The number of possible equipment and test equipment displays was very large. The HP 652A, the smaller of the two pieces of equipment used, contained a minimum of 280 possible points of test. (Many points of test have several locations; in situations like this, only one was counted.) If one assumes six system states, six range and function settings for an oscilloscope used for testing, and 24 range and function choices for the voltmeter to be used in testing, then there are 241,920 possible test displays. Judicious selection of problems and system states reduced this number to 41 waveforms, 25 voltmeter faces, and six front panel displays.

The large reduction in total displays required was achieved by choosing system states for the oscillator which were frequency or amplitude multiples of each other. This permitted repeated use of the same waveform display in association with different settings of the oscilloscope used for troubleshooting. The VOM displays were disassociated with the range and function choices so that 25 displays covered all possible meter displays (one display for every other minor scale division on the DC scale). This practice provided a voltmeter display within the combined tolerance of the prime equipment and the VOM for any possible value.

The sequential matrix format was selected as the mechanism for fixing the relationships of the variables to arrive at an output display. The matrix sequence followed the usual diagnostic protocol of:

1. Selecting a system state and point of test.
2. Deciding on a diagnostic test and specifying the test equipment required.
3. Setting up test equipment (selecting range and function).
4. Connecting test equipment to observe test display.
5. Analyzing results, repeating sequence, or making indicated repair.

The matrix sequence was begun by physically selecting a point of test from equipment photographs with points of test numbered. System states were selected from equipment line drawings depicting the various combinations of front panel control settings. Desired test equipment was selected by going to the proper matrix. Test equipment range and function selections were made from line art drawings depicting the various function and range combinations.

The SPT was designed to provide the troubleshooter with both the same information requirements and the same information sources found in the real-life troubleshooting setting. Troubleshooting is, in part, a complex information-gathering process modified by a strategy as collected information is analyzed by the troubleshooter. The information-gathering process is physically represented by the equipment to be repaired, the test equipment utilized during the information gathering, and the equipment maintenance manuals.

The SPT design provided the troubleshooter with the physical cues (in symbolic form) found on the job, allowing the troubleshooter to utilize the strategy of his choice.

The SPT materials included the following:

1. The Equipment Maintenance Manual
2. Equipment Photographs to Locate Points of Test
3. Symbolic Depiction of the System States Available for Troubleshooting
4. HP 410C Voltmeter Displays
5. HP 410C Function and Range Displays
6. TEK 453A Displays
7. TEK 453A Set-Up Choice Displays
8. Conversion Charts
 - a. Point of Test by System State
 - b. System State by HP 410C (Range and Function)
 - c. System State by TEK 453A (Set-Up Choice)
9. Front Panel Displays

Subjects taking the SPT began the test when they received a write-up which tersely described the malfunction, as an equipment operator might. The subject was free to manipulate front panel controls and note the reaction on front panel displays by choosing a system state (a combination of front panel control settings) from an illustration and then being referred to an illustration which pictured the resulting front panel displays. Different displays were available for each choice of system state and for each malfunction.

The subject was also free to make electrical tests using a VOM or an oscilloscope. In this case, the subject would work through the symbolic materials by choosing from illustrations and tables: a point of test, a system state, a test instrument, and a range and function for the test instrument. After making all the required choices, the subject

would then be referred to an illustration of the test instrument display in which he would obtain the test result.

Figure 7 illustrates all of the possible use paths through the SPT materials. Refer to the figure during the following discussions of the test materials and their use.

Locating Points of Test. Normally, the first two decisions made in a troubleshooting sequence are (1) where the test should be made, and (2) how the equipment controls should be set. The SPT sequence was begun by identifying the desired point of test. This was done in two steps. The first step was to look at the overall equipment photographs (general locator) and identify the circuit board or chassis area containing the desired components or point of test. The general locator referred the subject to a second (more detailed) photograph which depicted the components as they appear in the equipment. The subject located the desired point of test on this photograph. Each point of test was designated with an arrow and identified with a code number (Figure 8). Once the desired point of test code number was obtained, the subject proceeded either to the Point of Test/System State Conversion Table (for front panel, AC, DC, or Scope tests) or to the Voltmeter Conversion Table for Ohms (for resistance checks).

Point of Test/System State Conversion. This conversion was accomplished in a simple matrix. Refer to Figure 9 for the matrix format.

The matrix was entered in the left column with the previously determined Point of Test I.D. number. The I.D. numbers were in numerical order to make finding any given number easy. Once the I.D. number row was located, the subject specified a system state by choosing one of the illustrated system states and finding its code number in the remaining column headings.

The subject read down the desired column to the intersection of the test point I.D. number row. That cell contained the system-state guide number required to access a front panel display, or an AC, DC, or Scope measurement. For example, if the point of test was a front panel display (M1 on the HP 652A), the subject would go to the front panel displays section. If not, he would then specify the nature of the desired test (AC, DC, waveform) by using the conversion table associated with the test instrument and function (Voltmeter Conversion Tables: AC, DC+, DC-, or Scope Conversion Table).

Voltmeter AC and DC Conversions. Refer to Figure 10 during the following discussion. The subject used this form just as he did the Point of Test/System State matrix. (Note: Only one point of test was specified for the AC and DC conversions. The other point of test was understood to be common or circuit return.) The subject selected the appropriate range setting by viewing an illustration and obtaining a code number for function and range. These code numbers represented the column heads. The number at the intersection of the system state/test

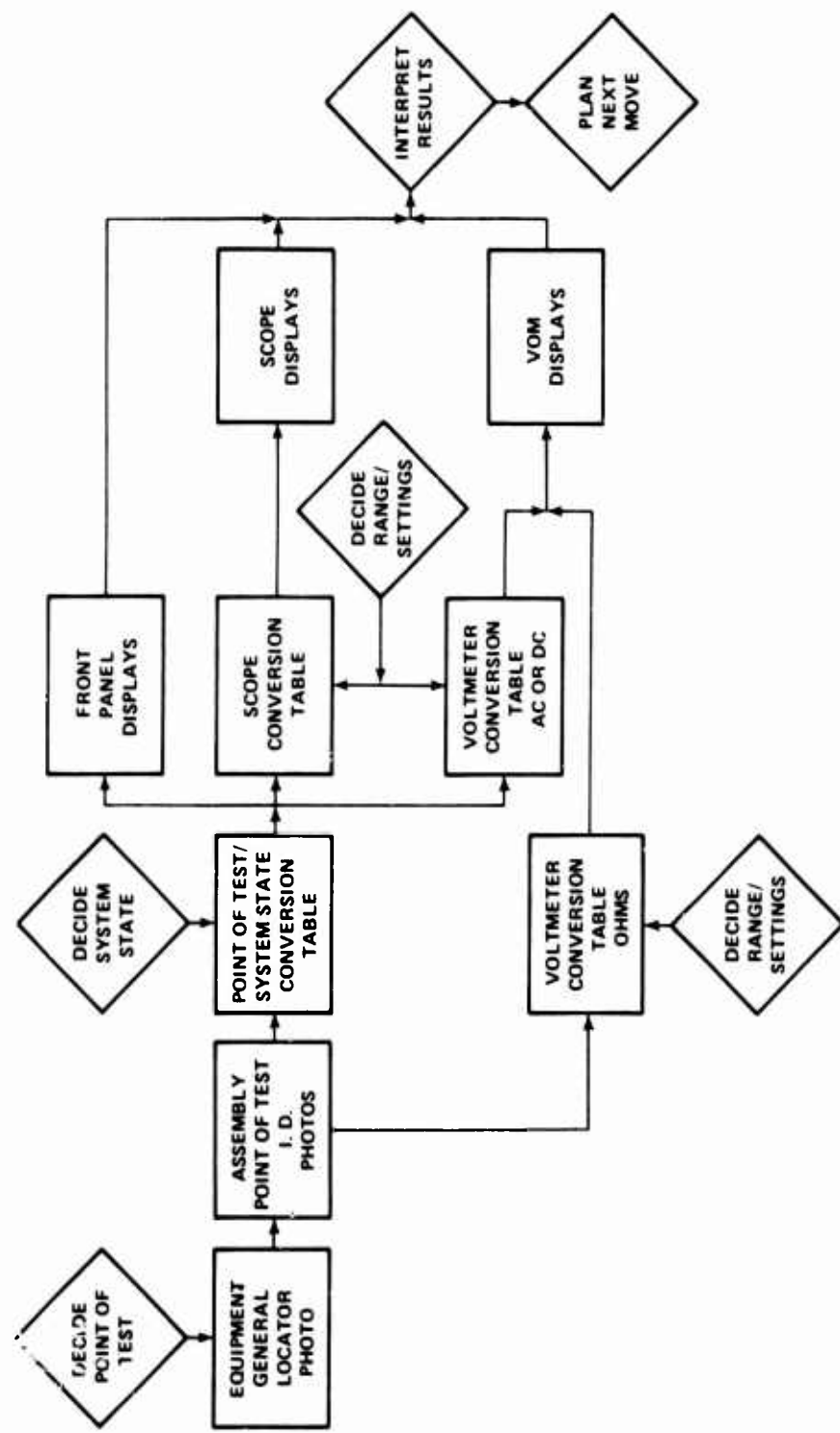
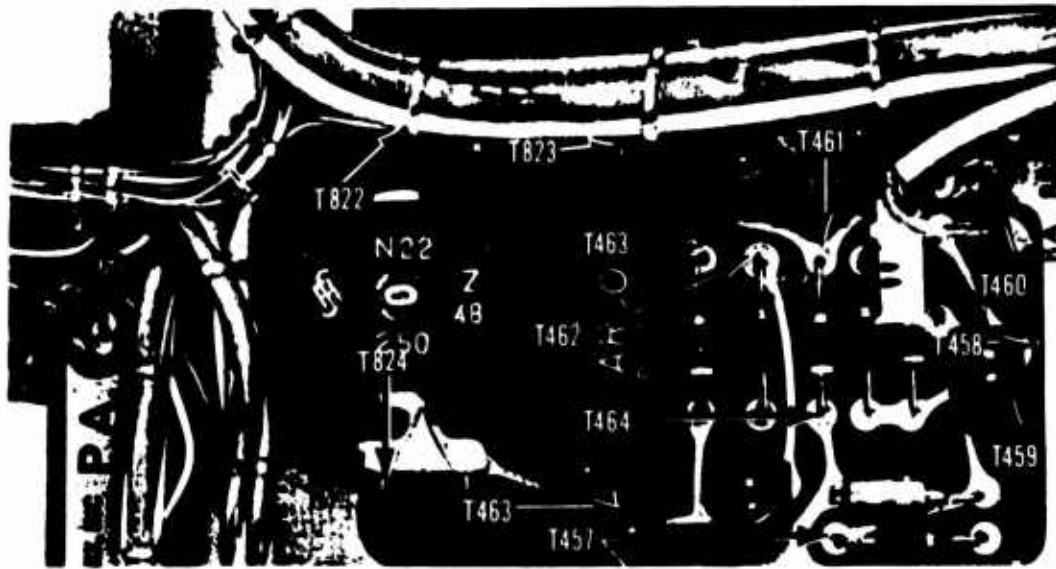

Figure 7. Sequence of Test Materials Use



K

Figure 8. Point of Test Locator

	1	2	3	4	5	
POINT OF TEST I.D.	GUIDE NOS.	GUIDE NOS.	GUIDE NOS.	GUIDE NOS.	GUIDE NOS.	GUIDE NOS.
T1	S1	S2	S3	S4	S5	S6
T2	S7	S8	S9	S10	S11	S12
T3	S13	S14	S15	S16	S17	S18
T4	S19	S20	S21	S22	S23	S24
T5	S25	S26	S27	S28	S29	S30
T6	S31	S32	S33	S34	S35	S36
T7	S37	S38	S39	S40	S41	S42
T8	S43	S44	S45	S46	S47	S48
T9	S49	S50	S51	S52	S53	S54
T10	S55	S56	S57	S58	S59	S60
T11	S61	S62	S63	S64	S65	S66
T12	S67	S68	S69	S70	S71	S72
T13	S73	S74	S75	S76	S77	S78
T14	S79	S80	S81	S82	S83	S84
T15	S85	S86	S87	S88	S89	S90

Figure 9. Point of Test/System State Conversion Table

point and range and function was the guide number to a meter display illustrating the test result.

VOLTMETER CONVERSION TABLE: AC

SYSTEM STATE GUIDE NUMBER	19	20	21	22	23	24
S1	V23	V15	V2	V4	V9	V20
S2	V14	V12	V20	V8	V20	V20
S3	V2	V19	V8	V4	V4	V4
S4	V19	V21	V11	V8	V12	V12
S5	V21	V7	V6	V5	V9	V20
S6	V20	V20	V20	V20	V20	V20
S7	V8	V12	V5	V4	V4	V4
S8	V11	V6	V7	V3	V4	V4
S9	V9	V8	V7	V7	V8	V20
S10	V11	V2	V3	V6	V20	V20
S11	V3	V4	V7	V12	V20	V20
		V9	V5	V7	V7	V20
					V9	V9

Figure 10. Voltmeter Conversion Table: AC

Voltmeter Ohms Conversion. The ohms conversion was similar to the AC and DC versions, except that the first column contained dual entries for the point of test (Figure 11).

The dual point of test columns were identified by ohmmeter leads. This permitted forward and reverse resistance readings on diode and transistor junctions since all points of test were covered sequentially (e.g., T1-T49 was also included as T49-T1).

All entries in the dual column were in first-column numerical order for easy access.

Front Panel Displays. The front panel displays were illustrations of the subject equipment with switches set appropriately for selected system states, and with the appropriate meter face or display given the system state and the malfunction. The desired display was identified on the Point of Test/System State Conversion Table.

VOLTMETER CONVERSION TABLE: OHMS

POINTS OF TEST		25	26	27	28	29	30
COM	DCA OHMS						
T1	T49	V23	V7	V6	V4	V18	
T2	T58	V14	V19	V3	V5	V23	
T3	T47	V19	V8	V7	V3	V20	
T4	T63	V18	V8	V6	V20	V20	V
T5	T110	V17	V11	V6	V3	V20	V
T6	T12	V9	V10	V14	V2	V20	
T6	T14	V3	V2	V11	V9	V7	
T6	T19	V17	V15	V25	V20	V20	
T7	T19	V4	V3	V2	V20	V20	
T7	T20	V5	V9	V3	V8	V12	
T7	T24	V5	V3	V2	V11	V20	
T8	T9		V2		V20		

Figure 11. Voltmeter Conversion Table: Ohms

Voltmeter Displays. There was a series of meter readings associated with Voltmeter Conversion Guide Numbers (Figure 12). The correct display was the one carrying the guide number obtained for a specific check in the Voltmeter Conversion Table.

Oscilloscope Displays. The scope waveforms were identified by a guide number obtained in the Scope Conversion Table. The scope conversion guide numbers were associated with individual waveforms, just as the meter displays were. See Figure 13 for a sample of the scope displays.

SPT Materials Development

The information contained in the sequential matrices was obtained by actually performing the indicated measurements. Three items each were developed for the HP 652A and the TEK 453A for a total of six. The system states and the scope and VOM ranges and functions to be included were specified for each piece of equipment prior to collecting the measurements and remained the same for all items on a particular piece of prime equipment.

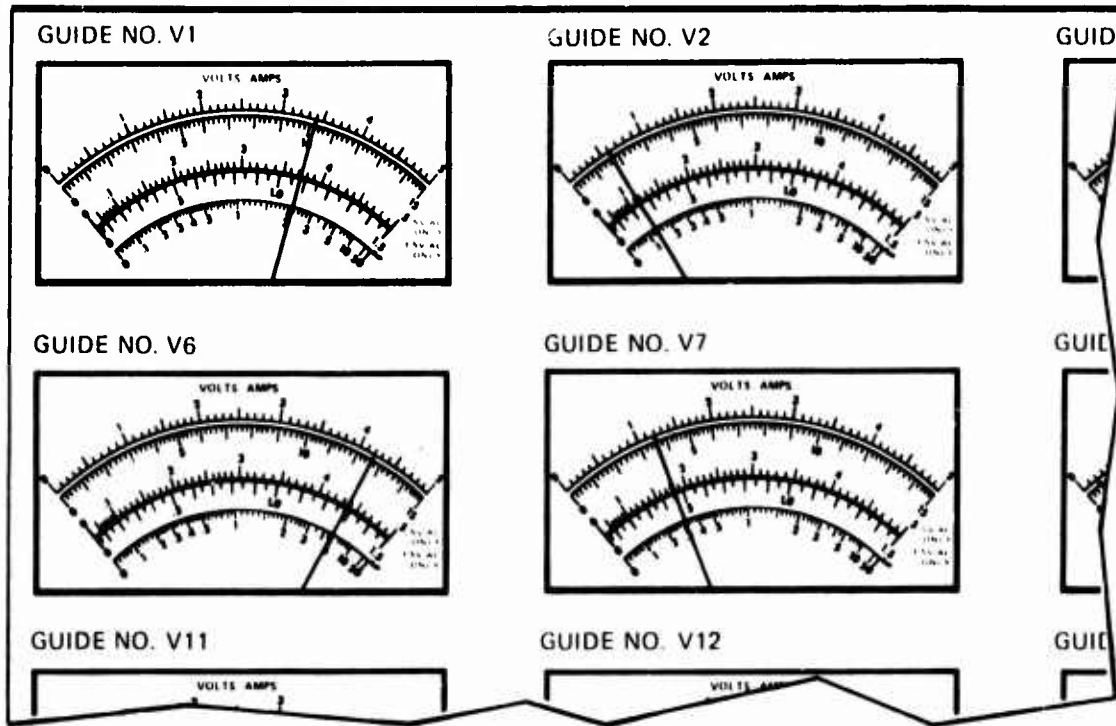

Figure 12. VOM Displays

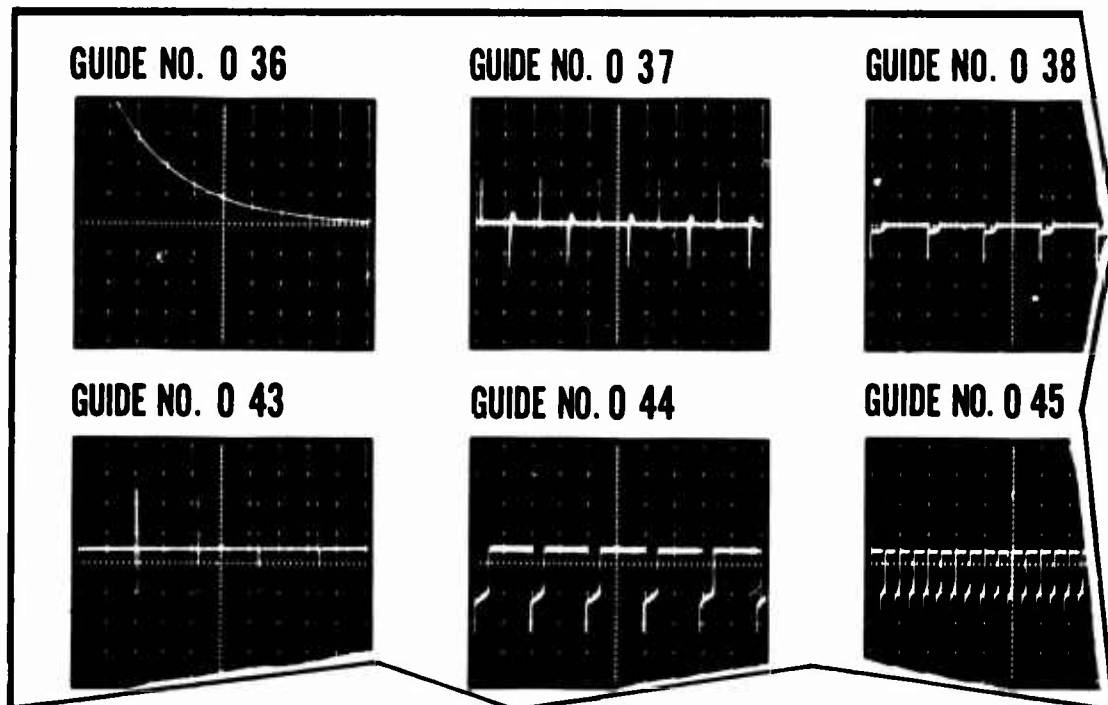

Figure 13. Scope Displays

The previously designed and tested malfunctions (items) were installed individually. Measurements were made with both the scope and VOM at each point of test, in each system state, and at each specified test equipment range and function.

The number of tests to be made was also very large. Several measures were taken to reduce the required number of measurements. These measures included taking all readings with all test equipment with no malfunction installed, then installing a malfunction and retaking only the affected readings. The number of readings was also reduced by eliminating those readings which were irrelevant, such as VOM RMS values in DC circuits; in most cases, RMS values were provided only in the power supply circuits. Waveform coverage was limited to those circuits producing periodic signals. With the VOM, it was not necessary to repeat measurements on different voltage ranges because of a sufficiently high meter input impedance. It was necessary, however, to measure resistances in semiconductor circuits on each range because of different ohmmeter output impedance on each range. By limiting measurements to relevant parameters, the number of required measurements was reduced from a few hundred thousand to a few thousand.

Preliminary Tryout

The preliminary tryout was held to debug the test materials and instructions. The JST and SPT test materials used were for the HP 652A.

The tryout was conducted using an industrial electronics technician with qualifications roughly equivalent to those of an experienced PMEL technician or instructor. The subject completed six JST items (the three designated for the final testing and three alternates) and three SPT items.

Results. The subject correctly solved all JST and SPT problems. The subject's performance time on the JST was within the originally planned 60 minutes, while SPT performance time was significantly longer than 60 minutes on two of the three items.

The original answering scheme was judged too difficult, and the results were too unreliable. The answering scheme required the subject to identify the malfunctioning stage by listing the components making up the stage. This process was too judgmental to provide reliable results without a large amount of pretest training in stage identification.

The subject worked on the first symbolic item approximately 80 minutes before the administrator discovered an instruction omission and an SPT materials defect. Once the complete instructions were provided and the defect corrected, the subject completed the item satisfactorily. The symbolic materials did not address the scope probe attenuation factor. This accounted for the subject's difficulties with the first symbolic item. The original materials assumed that the normal (10X) probe

would be used; however, the probe was not pictured in the scope range and function choice illustrations.

Subject's Comments. The subject observed that one reason for longer performance times on the SPT was the limited number of test points provided. Test design provided for one physical location for each electrical point of test, whereas in the real equipment there may be several alternate physical locations for the same point of test.

The tryout technician preferred to use the oscilloscope for all diagnostic measurements, but was unable to do so since the SPT materials were designed to minimize test equipment overlap whenever possible.

The subject noticed some solder flux on the circuit boards in the area of the installed malfunction. The subject was not able to identify the malfunction visually, but to some extent received confirmation of being in the right "ballpark."

SPT Design Modifications

As a result of the tryout, some features of the SPT instructions and materials were modified. The changes are discussed below.

Answering Scheme. The problems associated with stage identification were eliminated by providing a standard set of stage definitions. The standard stage definitions were the maintenance manual schematics reproduced with partitioning lines drawn around individual stages. Each stage was assigned a reference number for answering purposes. A subsequent tryout demonstrated that the answering problem was solved and that time to solution was also reduced.

Oscilloscope Range and Function Drawings. These drawings were modified to include the probe. The probe was positioned so that the attenuation factor was visible in the illustration.

Points of Test. This problem was considered, but no changes were made to the test coverage. There was no doubt that by increasing the number of points of test the materials would be easier to use; however, finding desired points of test in actual equipment is often just as difficult.

Test Equipment Use. The intent was to provide point of test value information with the easiest-to-operate test equipment capable of accurately reading the parameter of interest. The rationale was that using more difficult-to-operate test equipment than is required to obtain a measurement is a more error-likely process.

In a few instances, the technical manual contained a measurement at a point of test not provided in the materials. In these cases, the materials were expanded to contain this overlap. No other changes were made.

Malfunction Insertion Techniques. New circuit boards were installed to replace the old ones which had evidence of soldering. Malfunctions in the oscilloscope JST were selected for plug-in components. Spare components were obtained and failed. During testing, bad components could be substituted for good ones by simply unplugging the good one and plugging in the bad.

Where there were no plug-in components in the oscillator, additional wires were added to the chassis wiring harness and connected to the circuit boards. These wires and connections were not visible. This wiring was then connected to switches which, when operated, installed or removed the malfunctions. These switches were placed inside a closed container where their positions and effects could not be seen or detected by the subjects.

Test Administration

Study Context

Troubleshooting performance was tested on two pieces of PMEL equipment: the HP 652A test oscillator and the TEK 453A oscilloscope. Each test contained three items, with an item being the isolation of a single malfunction to the stage level of penetration. Acceptable performance was criterion-referenced (go/no-go) and time to solution was measured.

Criterion and symbolic tests were given to 31 subjects: 15 apprentice level technicians (PMEL students), and 16 journeyman level technicians (PMEL course instructors).

Test Administrator Role

The administrator's role encompassed a variety of activities including:

1. Providing a project briefing.
2. Providing test instructions.
3. Checking out the time equipment before installing JST problems.
4. Assigning and installing JST problems.
5. Monitoring JST and SPT activity.
6. Scoring JSTs and SPTs.

7. Providing subjects with SPT briefing.
8. Demonstrating SPT practice problems.
9. Monitoring additional SPT practice.
10. Assigning SPT problems.

JST Equipment Checkout and Problem Installation. The administrator verified proper operation of the prime equipment before installing a JST problem. The administrator also verified the malfunction after installing a problem.

Student-induced malfunctions (e.g., shorting test points to ground) were handled in one of two ways:

1. If the administrator noted the exact moment the student caused a malfunction, the problem timer was stopped and the subject given a break while the administrator repaired the equipment. Once the equipment was repaired, the student resumed and the timer was restarted.
2. If the administrator detected a student-caused problem after its introduction, the student was given a break and the equipment was repaired. The timer was then reset and the student started the problem over.

SPT Practice Problems. SPT sample materials were developed to be used by the administrator to demonstrate the SPT concept. The sample materials contained two short problems which the instructor solved in a demonstration for the SPT subjects. The sample problem materials are contained in Appendix A of this report. The SPT subjects were then given an actual SPT problem on the HP 652A as a practice item. The subjects solved this problem with no time limit, since the practice item was intended to familiarize the subjects with the materials. The sample problems and practice problem were prerequisites for participation in the SPT.

Problem Order Assignments. Since the JST and SPT items for an individual piece of prime equipment were the same, the order of presentation for each subject between JST and SPT was varied. The order of presentation between subjects was also varied to prevent association of answer with presentation order, and to insure that subjects were not working on the same item at the same time during data collection.

Figure 14 is a sample problem assignment record. It contains the item presentation order combinations used.

TESTEE NAME	JOB SAMPLE	SYMBOLIC
1.	*1, 2, 3	2, 3, 1
2.	2, 3, 1	*3, 2, 1
3.	*3, 1, 2	1, 2, 3
4.	2, 1, 3	*2, 3, 1
5.	*1, 3, 2	1, 2, 3
6.	3, 2, 1	*3, 1, 2
7.	*2, 3, 1	2, 1, 3
8.	1, 2, 3	*1, 3, 2
9.	*3, 1, 2	1, 2, 3
10.	2, 1, 3	*3, 2, 1
11.	*1, 3, 2	3, 2, 1
12.	3, 2, 1	*2, 3, 1
13.	*2, 3, 1	2, 1, 3
14.	1, 2, 3	*3, 1, 2
15.	*3, 1, 2	1, 3, 2

*Subject begins with this test form.

Figure 14. Problem Assignment Sheet

Test Site Layout

Refer to Figure 15 for the test site floor plan. The JST carrels were created by separating two work benches with a portable visual barrier. The SPT carrels each consisted of two 30 by 60 inch tables. The SPT carrels were also separated with a portable visual barrier.

In addition to the prime equipment, each JST carrel was supplied with an HP 410C transistorized voltmeter and a Tektronix 453 scope to be used as troubleshooting test equipment. The prime equipment had all access covers removed, eliminating the time required to remove them and eliminating the subjects' need for hand tools. Each carrel also contained a clock with a start/stop switch to serve as a timer.

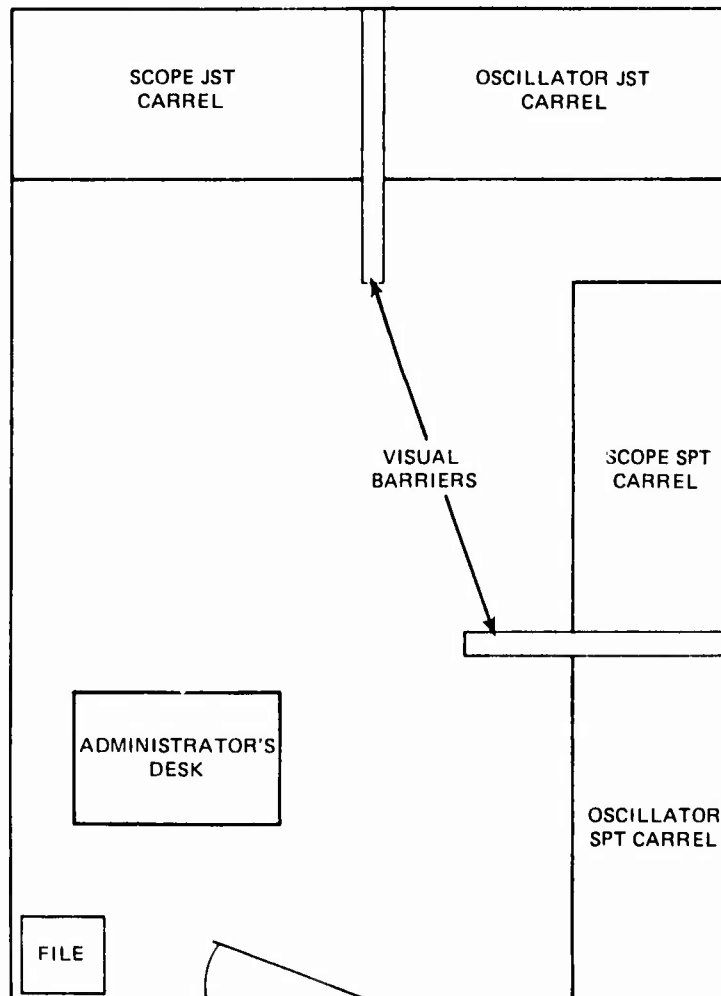

Figure 15. Test Site Floor Plan

Data Collected

The data were collected on two sources: an answer card (Figure 16) and a protocol record (Figure 17).

The test administrator started, stopped, and reset the timers in each carrel. The timer was started when a subject began a problem and was stopped when the problem was completed. The test administrator noted the elapsed time on the answer card. The subject entered his choice of defective stage on the answer card.

The subjects completed the JST or SPT Record as they worked through the problem solution. The subject recorded each diagnostic check and the point tested within the equipment on this form.

ANSWER CARD	
Name	<u>John Doe</u> Date <u>9-22-77</u>
Social Security No.	<u>██████████</u>
Problem No.	<u>2A</u> Total Time <u>37 min.</u>
Complaint	<u>Meter indicates 0 in normal.</u>
Defective Stage No.	<u>45</u>

Figure 16. Answer Card

Scoring

The test administrator checked the defective stage choice and indicated either correct or incorrect. The elapsed time was considered in the analyses as time to completion.

The test records yielded steps to completion by counting the number of diagnostic checks made.

The accuracy (correct versus incorrect), time to completion, and steps to completion raw data are included in Appendices B, C, and D, respectively.

Name _____ SSN _____

Date _____

Problem No. _____

JST RECORD								
CHECK NUMBER	POINT OF TEST	KIND OF TEST						TEST RESULTS (READING OR VALUE)
		ACV	+DCV	-DCV	SCOPE	OHMS	FRONT PANEL	
1								
2								
3								
4								
5								
6								
7								
8								
9								
10								
11								
12								

Figure 17. Sample Protocol Form

RESULTS

Introduction

The following section examines the JST and SPT results. The results are first viewed combined; i.e., all subjects, all problems. Secondly, the subdivisions of subjects and treatments are examined individually to determine their effects on the outcome.

Summary Output Results

The three measures of comparison between JST and SPT performance are accuracy (correct or incorrect), time to completion, and steps to completion. Accuracy data were expressed in mean percent correct, and time data were expressed in minutes to completion.

Accuracy: JST versus SPT

There are two important aspects of the accuracy results. The first is that the overall accuracy (correct versus incorrect solution) was very low; subjects failed approximately two problems out of every three, partially because only one try was permitted. The second is that there was a total of six items for each treatment group (JST/SPT) resulting in only six data points to produce the accuracy means. The resulting step function between scores possible (i.e., 16, 34, 50, 67, 83, 100) tended to suppress accurate correlations.

Figure 18 illustrates the accuracy grand means for JST and SPT. Correlation between mean scores was +.384 which is significant at the .025 level.

In his discussion of measuring association in ordered classes, Hays (1963) said ". . .the value of the τ statistic itself does not seem to have a very simple interpretation when ties are present in either ranking. This difficulty is removed if one uses the γ statistic suggested by Goodman and Kruskal (1954) specifically for data arranged in ordered classes [p. 655]." The formula for the Goodman-Kruskal (GK) gamma is:

$$\Gamma = \frac{N_c - N_d}{N_c + N_d}$$

where N_c is the number of concordant sets and N_d is the number of discordant sets. This statistic is interpreted like a correlation coefficient.

GK gammas are reported for comparison with the accuracy correlations since the gammas are more sensitive to associated relationships.

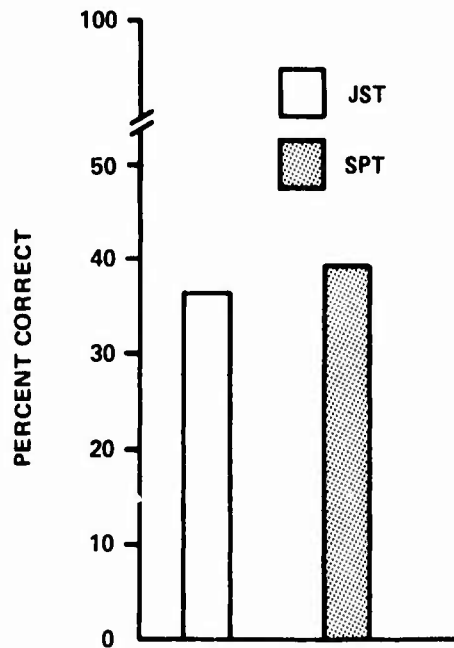

Figure 18. Accuracy Grand Means

In this case, looking at pass-fail results for each set of JST/SPT problems, the GK gamma is $+0.376$ which closely parallels the correlation coefficient of $+0.384$.

Time to Completion: JST versus SPT

Figure 19 illustrates the time to completion grand means of JST and SPT tests. Correlation between times was $+0.588$ which is significant to the $.0005$ level. Time to completion was limited at the high end by a maximum limit of 60 minutes. Subjects that did not solve the problem in 60 minutes ("timed out") were also given a fail on the accuracy measure. There was a total of 28 "time outs" out of 372 trials. Approximately 7.5 percent of the data was influenced by "time outs." The "time out" effects on the grand means are minimal, since they are less than 30 minutes. The restriction in range probably suppressed slightly the obtained correlations.

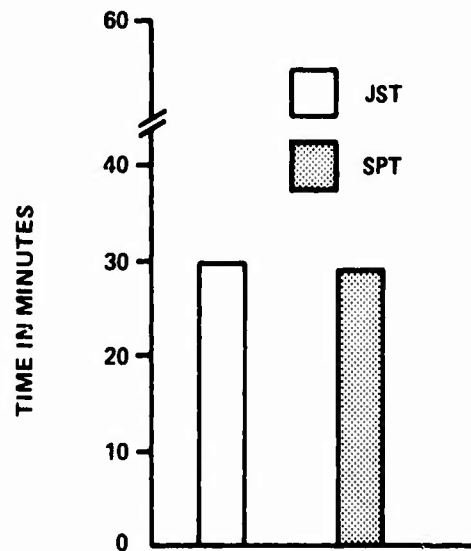

Figure 19. Time to Completion Grand Means

Steps to Completion: JST versus SPT

Figure 20 illustrates the steps to completion grand means for JST and SPT tests. Correlation between scores was $+0.356$ which is significant at the $.025$ level. Steps to completion is viewed as the least significant output measure for demonstrating similarity since it is also related to time to completion (i.e., the greater the number of steps to completion, the longer it will take to perform them). It is interesting to note the mean time per step, using the data from Figures 19 and 20 is 4.54 minutes per JST step and 6.47 minutes per SPT step. The SPT steps took on the average 42-1/2 percent longer to perform than the JST steps. This fact was sensed and mentioned by many of the subjects in their comments on the SPT. Working through the SPT photographs and sets of matrices appears to take longer than performing a check on the actual equipment.

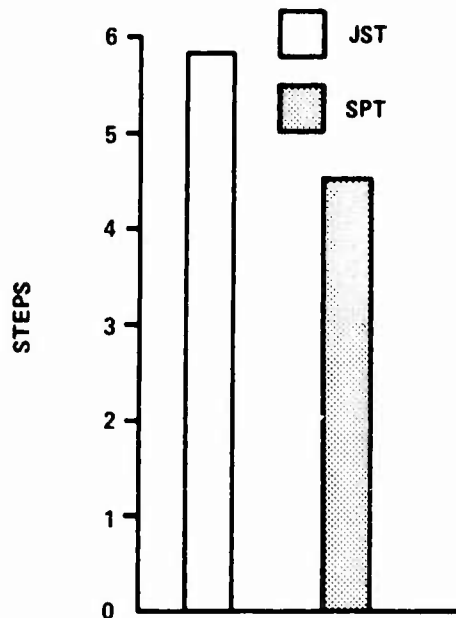

Figure 20. Steps to Completion Grand Means

Factors Affecting the Summary Accuracy Correlation

As one might expect, several subject and treatment features had some effect on the summary accuracy correlation. The significant effects are discussed below.

Accuracy: Students versus Instructors

Figure 21 illustrates the accuracy grand means for students and instructors for both JSTs and SPTs. The JST/SPT accuracy correlation for instructors was $+0.628$ which is significant at the $.0005$ level. The JST/SPT accuracy correlation for students was $-.041$ which is not significant. The low student correlation accounts for the abnormally low value of the overall accuracy correlation. However, the instructor GK gamma was $+0.31$ while the student GK gamma was $+0.44$. The GK gamma depicts a more consistent level of performance between these two groups than the correlations do.

Student JST results matched SPT results (right on JST and SPT or wrong on JST and SPT) 72 percent of the time, while instructor results matched 65.6 percent of the time.

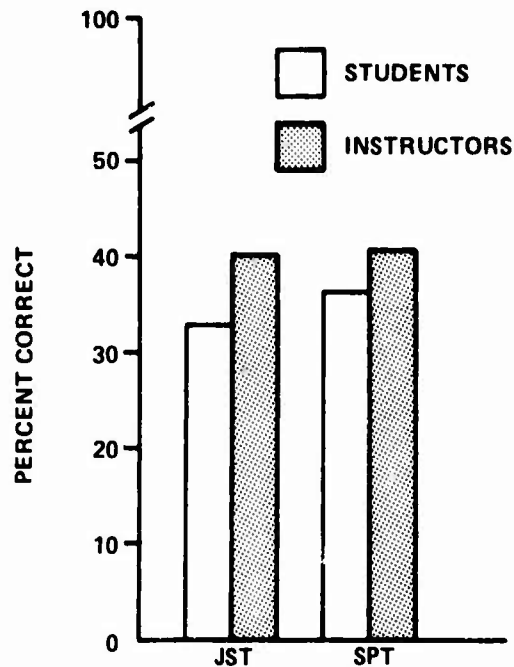

Figure 21. Accuracy Grand Means for Students and Instructors

Accuracy: Oscillator Problems versus Scope Problems

Figure 22 illustrates the accuracy grand means for scope and oscillator for both JSTs and SPTs. The correlation for oscillator JST and SPT items was $+0.29$ which is not significant. The corresponding scope correlation was $+0.48$ which is significant at the $.005$ level. The GK gammas are as follows: oscillator $+0.31$ and scope $+0.44$. The oscillator JST results matched SPT results 61 times out of 93 possible or 65.5 percent of the time. The scope JST results matched SPT results 69 times out of 93 possible or 74 percent of the time.

Oscillator Accuracy: Students versus Instructors

Figure 23 illustrates the oscillator accuracy grand means for students and instructors.

The correlation for student JST/SPT performance was $+0.19$ which is not significant. The correlation for instructors was $+0.34$ which also is not significant.

The GK gammas are as follows: students $+0.47$, instructors $+0.16$. The GK results contradict the correlations, which suggests that the correlations may not be as appropriate as the gammas for judging the similarity

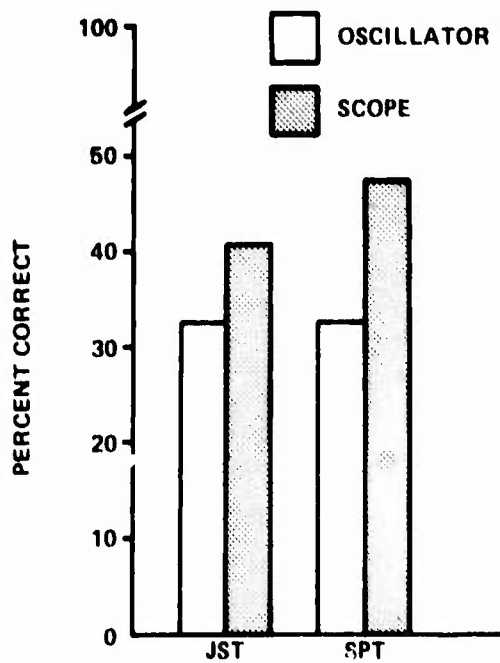

Figure 22. Accuracy Grand Means for Scope and Oscillator

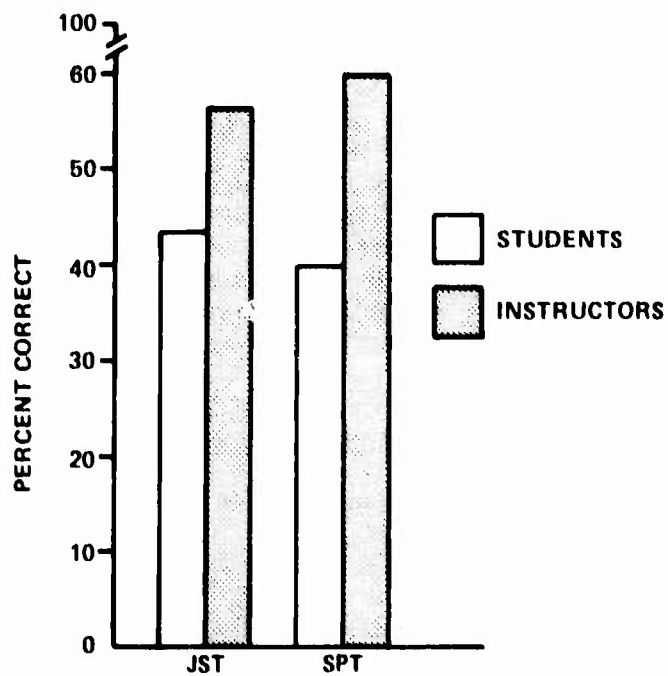

Figure 23. Oscillator Accuracy Means for Students and Instructors

of performance in this case. Student results matched 33 times out of 45 trials or 73 percent of the time. Instructor results matched 28 times out of 48 trials or 58 percent of the time.

Scope Accuracy: Students versus Instructors

Figure 24 illustrates the scope accuracy grand means for students and instructors.

The correlation for student JST/SPT performance was +.42 which is significant at the .05 level of confidence. The correlation for instructors was +.54 which is significant at the .025 level of confidence.

The GK gammas are as follows: students +.42, instructors +.46. Student results matched in 32 of 45 trials or 71 percent of the time. Instructor results matched 35 out of 48 trials or 73 percent of the time.

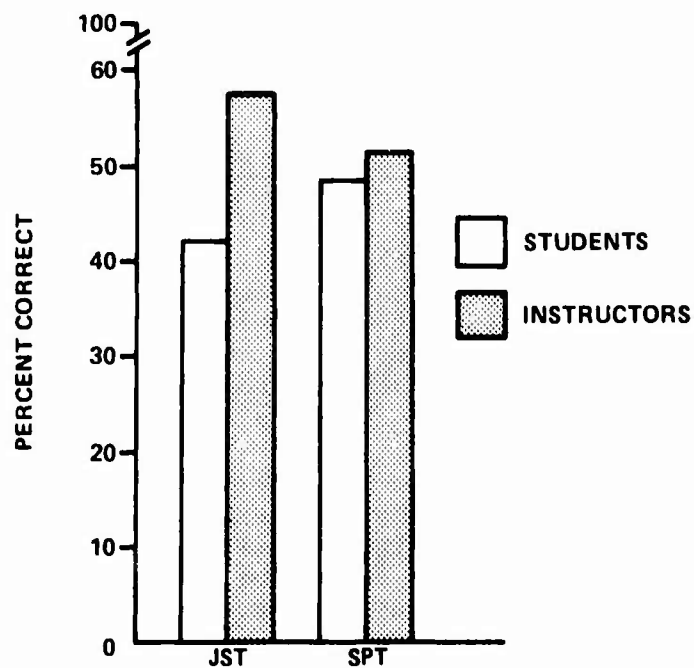

Figure 24. Scope Accuracy Means for Students and Instructors

Factors Affecting the Summary Time Correlation

It may be difficult to conclude that performance time is similar for the different treatments (JST and SPT) based on time alone when the task to be performed (at the step level) is not controlled. That is, the technician may use different numbers of steps and in different order to solve each presentation of the problem. In this study, the task was not controlled; however, the protocol data suggest that the same strategies were followed in both test formats. Correlations for student and instructor time to completion for JST and SPT are as follows: students +.72, significant to the .005 level of confidence; instructors +.63, significant to the .0005 level of confidence. Correlations between oscillator and scope JST and SPT problems are as follows: oscillator +.56, significant to the .0005 level of confidence; scope +.39, significant to the .025 level of confidence.

The summary time correlations were quite high and significant. If one accepts that the tasks performed were similar on the basis of the protocol analysis of strategy, then one must conclude that, time-wise, performance was similar regardless of presentation mode.

Presentation Order Effects

Each subject received each test item twice, once as a JST problem and once as an SPT problem. It was possible that performance on the second presentation could be affected by the previous exposure. First exposure as used here is equivalent to the test form (JST or SPT) initially worked by a subject. The second exposure is equivalent to a retest in the other test form.

In a test/retest situation such as this using the same limited numbers of items, it was reasonable to expect some improvement on the retest. The expectation is that the initial encounter will produce some learning; however, on such a small test there is the fear of test compromise. The following discussion reviews the effects of presentation order on each of the performance measures.

Presentation Order and Accuracy

Figure 25 compares the accuracy means of first and second presentation scores in several ways. First and second exposures for all subjects and both test forms are compared with the results of the student and instructor groups. The student and instructor results are compared with the SPT-first exposure contrasted against the JST-first exposure.

The data in each category of first- and second-exposure comparison were evaluated with the chi-square statistic. Chi-square was chosen in preference to a t-test since the accuracy data were seriously skewed toward the low end of the distribution (see Guilford, 1956, p. 221). This low end distribution is accounted for by the overall mean score of approximately 38 percent.

Using the chi-square evaluation, all of the first- versus second-presentation differences depicted in Figure 25 are significant beyond the .0001 level.

The pooled data comparison indicated a seven percent improvement between first and second exposures, which is far less than one would expect if the test had been compromised. The marked differences between first- and second-exposure results for students suggest that the students learned about the equipment, its technical data, and/or troubleshooting as a result of first-test exposure. The student improvement in accuracy on the second presentation regardless of format was approximately 13 percent. One would expect the instructors to be far more familiar with the equipment and to have adopted some troubleshooting philosophy and that one additional exposure to the equipment would produce little change in their performance. This hypothesis is partly borne out by the instructor results. Indeed, while the instructor differences were significant, the increment of change was many times less than that of the students.

While the student SPT-first means were somewhat lower than their JST-first means, it is important to note the 13 percent increment of improvement using the SPT first.

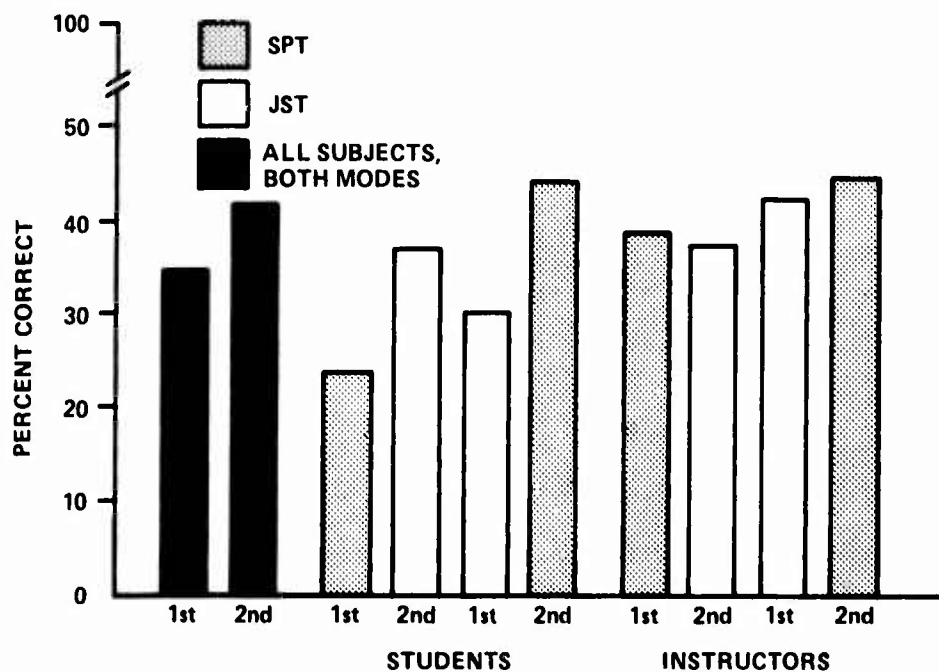

Figure 25. Presentation Order Effects on Accuracy

Presentation Order and Time to Completion

Figure 26 compares the time to completion means for the first and second exposures in the same categories as accuracy in Figure 25. The data were evaluated using t-tests. The t-tests indicated significant differences between the means in all categories except instructor JST-first.

The t-test results are:

Pooled: $t = 3.81$, significant at the .0005 level

Student SPT-first: $t = 2.76$, significant at the .05 level

Student JST-first: $t = 3.11$, significant at the .001 level

Instructor SPT-first: $t = 2.16$, significant at the .025 level

Instructor JST-first: $t = .81$, not significant at the .05 level

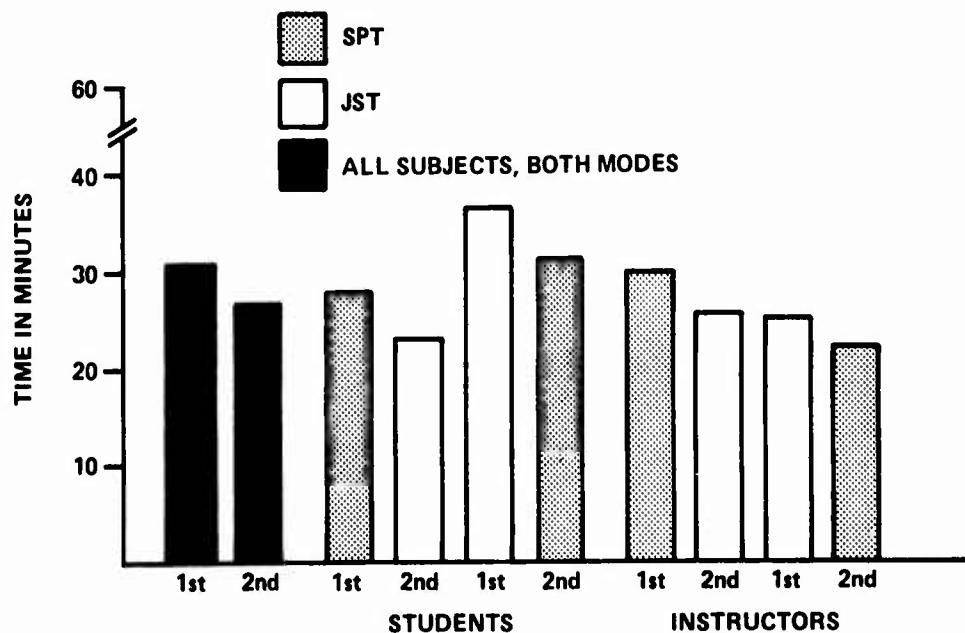

Figure 26. Presentation Order Effects on Time to Completion

Each category showed a decreased time to completion in the second presentation. The range of the decrease (2.68 to 5.2 minutes) again suggests that the test was not compromised. One would expect much shorter times on the second exposure if the test had been compromised.

An interesting comparison can be made between the student categories of SPT-first versus JST-first. The SPT-first group's time to completion on the SPT was faster than the JST-first group's time to completion on either test.

The students in the SPT-first group also had a faster time to completion when they took the JST than either of the instructor groups. A statistical comparison of the SPT-first student JST results, with the shortest instructor JST times showed no significant differences. A t-test revealed a t of 0.35 which is not significant at the .05 level.

A final point of interest is the instructor JST time scores; regardless of presentation order, their time to completion means were within 0.1 minutes. A t-test confirmed that there were no significant differences in these means. The t-statistic was: $t = .024$ which is not significant at the .05 level. This finding helps support the assertion made in the section on presentation and accuracy that one more exposure to the equipment for instructors should produce little change in the instructor performance.

Presentation Order and Steps to Completion

Figure 27 compares the steps to completion means for the first and second exposures in the same categories presented for accuracy and time in Figures 25 and 26.

The data were evaluated using t-tests. The t-tests indicated no significant differences between the means in all categories except instructor SPT-first.

The t-test results are:

Pooled: $t = .34$, not significant at the .05 level

Student SPT-first: $t = 1.26$, not significant at the .05 level

Student JST-first: $t = 1.46$, not significant at the .05 level

Instructor SPT-first: $t = -1.78$, not significant at the .05 level

Instructor JST-first: $t = 3.47$, significant at the .001 level

Again, the hypothesis for test compromise stated for steps to completion would be a significantly fewer number of steps to completion in the second encounter. While the difference was not significant, the pooled data indicated a slightly lower number of steps to completion for the second presentation.

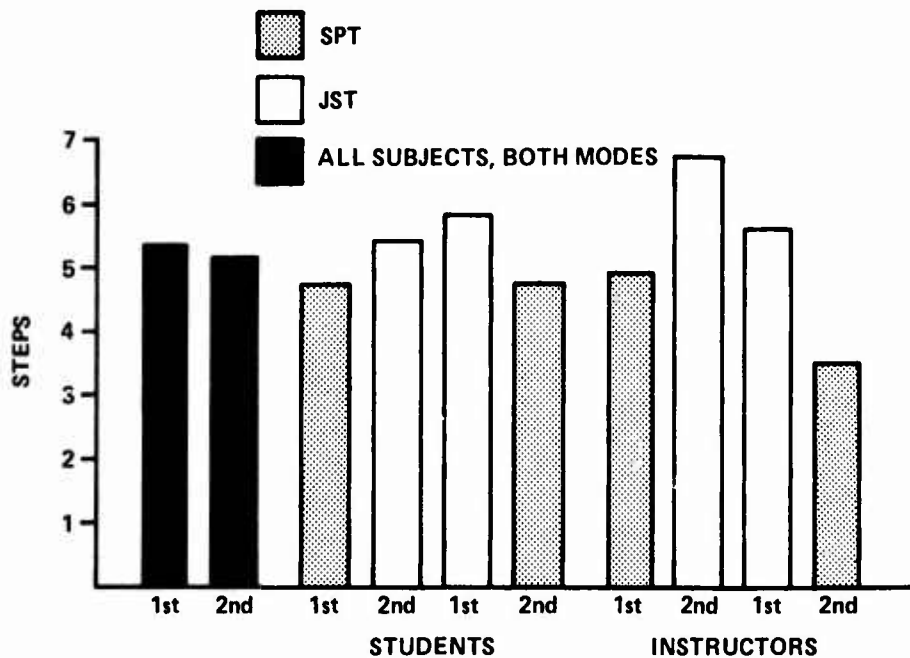

Figure 27. Presentation Order Effects on Steps to Completion

The protocol data does suggest that a few competent troubleshooters followed a systematic strategy to solve a problem on the first exposure, but went right to the suspect component and confirmed that it was the problem in the second exposure. However, the combined steps to completion data suggest that this was generally not the case.

Analysis of the student and instructor breakdowns in Figure 27 reveals one other important fact: In every case there were fewer steps to completion in the SPT format than in the JST format. This may be a function of SPT structure or volume of materials forcing more deliberate behavior.

Protocol Data

The protocol data consisted of the list of steps (and points of test) performed by the subject while attempting to solve each problem. The protocol records were analyzed for troubleshooting process information and were compared with an optimal solution. The comparison was made on a data flow drawing of the equipment at the stage level (see Figure 28 for an example).

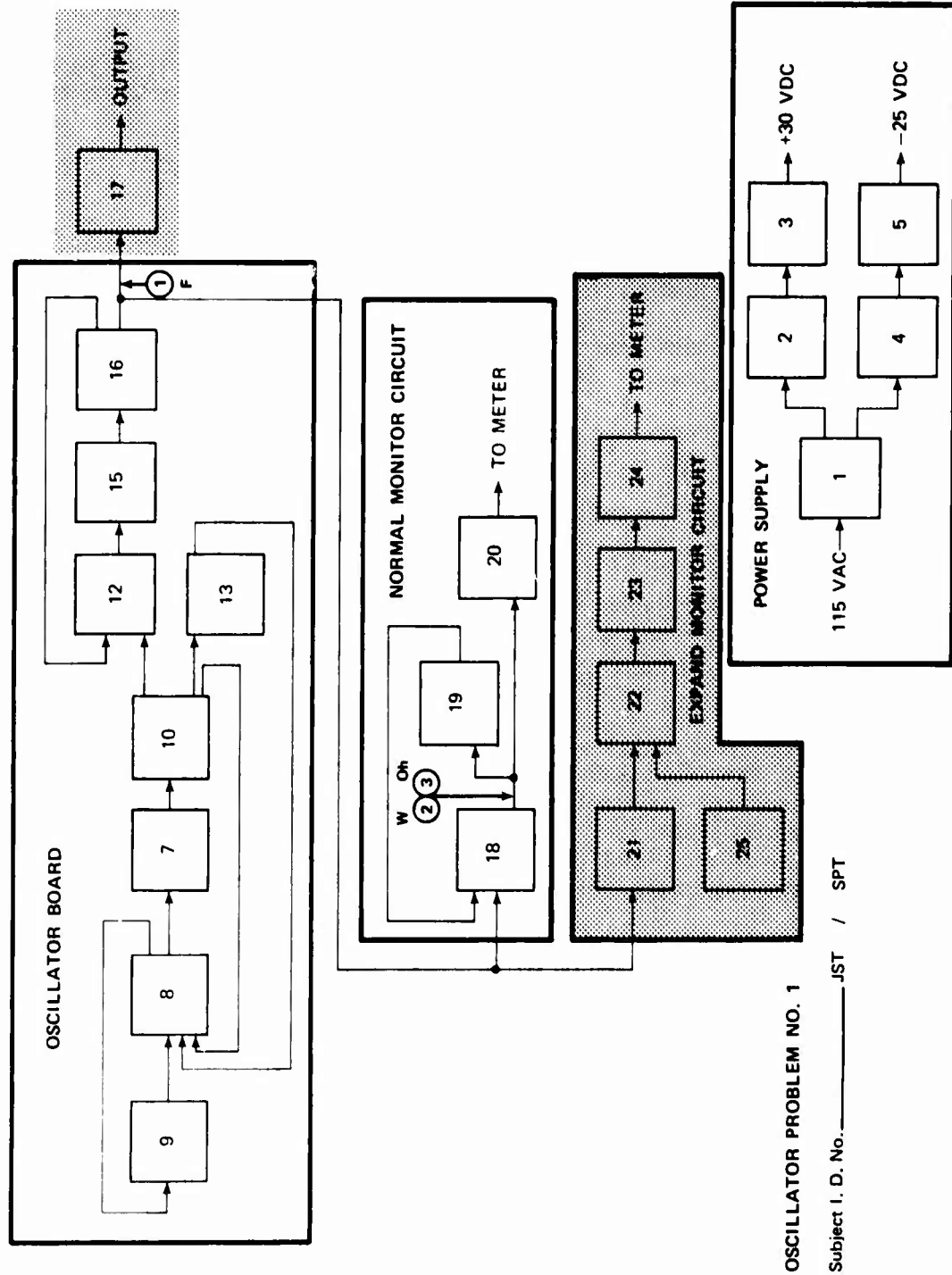

Figure 28. Protocol Map

The legitimate search field was indicated in the clear area. Subject's checks in the shaded portions were classed as irrelevant to the problem. The optimal solution was charted on the drawing both in terms of check location, type of check, and check sequence. Each subject's checks were also charted on the data flow drawing in the same manner. This permitted a direct comparison with the optimal solution.

The protocol analyses classified troubleshooting behavior in terms of approach to solving the problems. Each solution was compared to the following criteria:

1. Symptom Pattern Analysis--isolated suspect subset of possible causes from malfunction description.
2. Input Checks--checked input to suspect subset of data flow.
3. Output Checks--checked output of suspect subset of data flow.
4. Internal Checks--checked within suspect subset of data flow.
5. Power Supply Checks--checked unit common power supplies.
6. Irrelevant Checks--checked outside the subset of suspect components.

Protocol Results

Correlating the Symptom Pattern Analysis category results for all JST/SPT tests produced a correlation coefficient of +.962 which is significant at the .0005 level of confidence. This fact very strongly suggests that most subjects used the same (and an appropriate) strategy to find the problem, regardless of treatment.

The internal checks and output classes produced correlation coefficients of +.926 and +.916 respectively. The input check category produced a correlation coefficient of +.90. These correlations are all significant at the .005 level of confidence. This suggests that regardless of treatment, most subjects made an attempt to identify the problem by testing within the area of the equipment containing the malfunction.

Power supply checks are often a routine part of a troubleshooter's approach since they tend to be a common link to the remainder of the equipment. The power supply check category produced a correlation of +.748 between JST and SPT treatments, which is significant at the .025 level.

In the irrelevant check category, comparison of the JST/SPT treatments produced a correlation coefficient of +.469, which is not significant.

Problem Difficulty

The following analysis was performed to evaluate the problem difficulty algorithm which was developed during this study as an aid in selecting problems. The percentage of incorrect solutions was calculated for each test item. These scores were correlated with the level of difficulty numbers calculated using the problem difficulty algorithm. The correlation for the combination of all JST and SPT results is +.567, which is not significant with only six data pairs. The correlation for only JST results is +.642 which is significant at the .05 level of confidence. The correlation for only SPT results is +.467 which is not significant.

CONCLUSIONS

Introduction

The study objective was to develop and evaluate the practical usefulness of a paper-and-pencil simulation approach to performance testing in a technical training environment. Satisfying the underlying assumptions necessary to normal test instrument reliability and validity measures was waived in the study design to permit the demonstration to embrace as many of the real-world variables as possible. Emphasis in the design of the SPT was on content validity.

The major study variables which militated against demonstration of predictive validity included:

1. Items of widely varying difficulty.
2. Tests with few items ($N = 3$).
3. Subject groups of vastly differing backgrounds (students and instructors).
4. Small subject groups (Students = 15, Instructors = 16).
5. Tests on two different pieces of equipment.
6. Counterbalanced order of presentation for equipment, test format, and item.

In spite of the action of these factors, significant predictive validity was shown. Comparison of all subjects' JST versus SPT performance measures produced positive and statistically significant correlations. The correlation coefficients for accuracy, time to solution, and steps to solution are $+0.384$, $+0.588$, and $+0.356$ respectively.

The following section reviews the summary statistics for each of these measures to assess similarity of performance. SPT content validity and the problem difficulty metric are also examined in these conclusions.

Accuracy

The pooled (all subjects, correct versus incorrect) accuracy correlation was positive and significant; however, the potential magnitude of the correlation was suppressed by the variance in performance. This variance is contributed by:

1. Problem difficulty differences.
2. Low overall accuracy (37.7%).
3. Student and instructor differences.
4. Oscillator and oscilloscope problem differences.

Table 1 compares the accuracy correlations with the GK gammas. With the exception of the instructor and student JST/SPT correlations, the gammas closely parallel the correlations. If one accepts the gammas as more indicative of performance due to their associative nature, we must conclude that performance, accuracy-wise, was fairly uniform across these categories.

TABLE 1. COMPARISON OF ACCURACY METRICS

	JST/SPT	Instructor JST/SPT	Student JST/SPT	Oscillator JST/SPT	Scope JST/SPT
r =	+0.36	+0.63	-0.04	+0.29	+0.48
GK gamma =	+0.38	+0.31	+0.44	+0.31	+0.44

Time Correlations

The time differences are primarily a function of the order of presentation rather than test format. The increased time per step in SPT tests is probably a function of the volume of SPT materials which must be used to solve a problem. This limitation may have forced the subjects to consider more carefully their strategy while performing the SPTs. The test structure may also have eliminated some irrelevant checks. These conclusions are not obvious from the collected data; however, many subjects commented that the symbolic test was more difficult and that they learned a lot as a result of the testing.

The time correlations were high, positive, and significant, and lend support to the claim for test similarity made on behalf of accuracy. This argument is valid since the tasks performed in different treatment modes were similar in approach as seen through the protocol analysis results.

Problem Difficulty

Correlational methods did not produce significant agreement between the hypothesized problem difficulties and the empirically determined results. The correlation for combined JST and SPT difficulties compared to the hypothesized ones was +.567 which was not significant. However, a t-test performed on the same data suggests that there is no significant difference between the means. The t-statistic is .886 which is not significant at the .05 level. Table 2 compares the hypothesized and empirical item difficulties.

TABLE 2. HYPOTHESIZED AND EMPIRICAL ITEM DIFFICULTIES

Difficulty Factor	Item					
	S1	S2	S3	O1	O2	O3
Hypothesized	51.7	77.4	40.8	64.7	47.8	48.2
JST/SPT Combined	54.8	90.3	24.2	51.6	82.3	71.0
JST	51.6	96.8	29.0	51.6	77.4	77.4
SPT	58.1	83.9	19.4	51.6	87.1	64.5

The major differences occurred on oscillator problems 2 and 3. Reviewing the earlier accuracy data reveals that both subject groups appeared to have more than the expected difficulty with these problems. This finding suggests that the difference is equipment-related. A major difference between the oscillator and the scope is the extensive use of both positive and negative feedback in the oscillator circuitry. There is no question that feedback complicates the troubleshooting task. The unanswered question is whether the subject group is typical of the general population in this regard. If so, the problem difficulty algorithm is insensitive to this hardware feature.

While these results indicate that the algorithm requires some fine-tuning, the algorithm has been partially proven. The importance of the algorithm cannot be overstated. In future tests of this sort, developers will be limited by item development cost; prohibited from building a pool of items to establish empirical difficulty. The algorithm is at least a yardstick for gauging difficulty which can permit test developers to approximate difficulty and select roughly equivalent items for reliability and validity determinations.

Similarity of Performance

Similar performance is a measure of concordance (e.g., what percentage of the time were the subjects' responses for an item the same between test types: either both correct, or both incorrect). Table 3 compares two sets of concordant data. The gammas are Goodman-Kruskal indices of concordance which have the same range and interpretation as a correlation coefficient. The percent matched sets are determined as follows:

$$\% \text{ matched sets} = \frac{\Sigma (\text{JST}=\text{SPT})}{\Sigma \text{ Response Sets}}$$

TABLE 3. COMPARISON OF CONCORDANT ACCURACY RESULTS

	JST/SPT	Instructor JST/SPT	Student JST/SPT	Oscillator JST/SPT	Scope JST/SPT
GK gamma	+0.38	+0.31	+0.44	+0.31	+0.44
% matched sets	68.8	65.6	72.0	65.5	74.0

The protocol data confirm performance similarity in terms of strategy. Organized strategies were present in both JST and SPT solutions. The protocol results produced high, positive, and significant correlations (+0.96, +0.93, and +0.75) in the organized approaches categories.

The grand means for time, accuracy, and steps to completion also suggest little overall difference between JST and SPT treatments. These means are presented in Table 4.

TABLE 4. COMPARISON OF OUTPUT MEASURES BY TREATMENT TYPE

	Accuracy	Time to Complete	Steps to Complete
JST	36.6%	29.7	5.9
SPT	39.3%	29.2	4.5

When combined, the evidence overwhelmingly suggests a high degree of similarity between job sample and symbolic performance.

SPT Content Validity

The study was focused on troubleshooting to the stage level. The subtasks which make up generic troubleshooting are:

1. Manipulating equipment system state to discern the character or probable location of the malfunction.
2. Measuring operating signals anywhere within the equipment.
3. Selecting from normally available test equipment to measure operating signals.
4. Physically locating the desired point of test.
5. Choosing a measurement parameter.
6. Adjusting test equipment to measure the desired operating parameter.
7. Reading displays and factoring range and function information into values.
8. Planning or modifying troubleshooting strategy based on test results.
9. Using equipment technical data during troubleshooting.

The SPT materials used in this study addressed the component subtasks in generic troubleshooting by:

1. Providing access to front panel controls to allow changing system state.
2. Providing access to front panel displays in response to system state changes.
3. Providing access to all points of test.
4. Providing access to normally available test equipment.
5. Permitting subjects the choice of measurement parameters.
6. Providing access to test equipment range and function controls to permit selection of test parameters.

7. Providing test equipment displays to permit factoring of range and function information into values.
8. Designing the SPT materials to permit the subjects to follow the strategy of their choice.
9. Providing access to equipment technical data.

If one accepts that the list of generic troubleshooting subtasks is complete or at least contains the most important elements of the troubleshooting task, then one must conclude that the SPT content is similar to on-equipment troubleshooting task content.

Upon completion of the testing, each subject was asked to give the test administrator "feedback" or any relevant comments on either test. While the comments were solicited, they were provided voluntarily. Comments were received from 24 of the 31 subjects. Most of the subjects attempted to provide some constructive criticism of the SPT. These criticisms have been mentioned with the SPT features they pertained to elsewhere in this report. Approximately 40 percent of the comments addressed content validity. Typical comments were:

". . . overall, it [the SPT] was quite different from the standard theoretical troubleshooting [presently given in training] and I believe it's better. . . ." (An instructor)

". . . I think it [the SPT] was a reasonably good method and realistic too. I think it might be an effective aid to [learning] actual troubleshooting. You must apply the same mental logic in either method. . . ." (A student)

". . . once you get used to the system, it [the SPT] seems pretty good. . . ." (An instructor)

". . . the way that the paper-pencil [SPT] was presented was easily understood and the troubleshooting was easier [than JST] to do. I really enjoyed this class and feel that I have learned more [than in the present course]. . . ." (A student)

". . . my personal preference is the on-equipment test. The paper troubleshooting test is good though. I think it would be excellent, especially where equipment is not available for training. . . ." (A student)

Both from the analytic point of view and from the subjects' reactions to the SPT, one must conclude that the SPT content validity is quite high.

Discussion

The comparative measures individually or combined illustrate a high degree of performance similarity regardless of test format. The order of presentation data show that some learning occurred between presentations and that the instructor JST parameters were relatively unaffected by either another exposure or the symbolic format.

The reliability and validity of the technique as a performance measurement and prediction tool are yet to be demonstrated. However, refinement and use of the problem difficulty algorithm should reduce this to a routine effort.

The most provocative result is the similarity of performance regardless of format. It seems very likely that the symbolic materials are a substitute for the actual equipment and the troubleshooting environment, and could be used to practice troubleshooting in a technical training situation. From the subjects' comments, one could expect a fair degree of SPT acceptance from the students and instructors also.

The symbolic materials for this study were produced in a paper-and-pencil medium; however, it is a short step from paper and pencil to a computer presentation. An interactive computer terminal coupled with a graphics terminal or carousel projector would be required to replace the paper-and-pencil format. Whole class demonstrations would be possible if a slide projector was used to display the graphics. This change in medium would also satisfy most of the critical comments from the subjects on the volume of SPT materials.

In addition, the computer could be utilized in a self-instructional mode. The optimal strategy can be programmed in addition to the malfunction-specific data. The computer can provide the student with immediate feedback at each decision point in the problem-solving process on the student's choice of: points of test, test equipment, and test equipment range and function.

SUGGESTIONS FOR FUTURE RESEARCH

Introduction

The basic goal underlying the development of a valid SPT for troubleshooters is the potential savings in training equipment by substituting paper-and-pencil tests for actual operating equipment. This saving can be viewed as increased opportunity for each student to interact with the equipment. The approach featured in this study could be used to improve the quality of training.

Validity and Reliability Study

Before implementing the SPT process in Air Force technical training, it is necessary to demonstrate its validity clearly and unequivocally. Based on the present study, there are several features we recommend be part of a large-scale study.

1. The prime equipment used in the study should be widely used in the field so that a larger pool of experienced service personnel could be sampled. We recommend using only one piece of equipment and increasing the number of problems on it. This also simplifies test administration logistics and repair.
2. The test items should remain typical and of uniform difficulty.
3. The point of test location visuals should be in color. The specific points of test called out should always include individual circuit board connectors.

Computer Presented SPT

The SPT materials contained two types of visual materials: the sets of equipment photographs and drawings, and the cross-reference matrices. The matrices were the objectionable and difficult-to-use portions of the SPT materials, according to the subjects. Much of this objection could be eliminated if the tables were programmed into a computer and the subject simply responded to a computer prompt for each decision input.

The point of test location photographs would provide more visual information in color; they were black and white in this study. Shriver and Foley (1974) suggest the use of a random-access slide projector for visuals; within our study there were no advantages to using a projector. However, a slide projector with color slides for point of test and range and function information controlled by the computer would seem to be a natural combination.

The validity and reliability study should be run using a computer presented SPT. The visuals should be computer controlled color slides. The computer protocol should follow the decision sequence discussed earlier in this report.

The results should then be carefully compared to the validation study results. An important feature to study would be user acceptance of paper-and-pencil presentation versus computer presentation.

SPT Troubleshooting Practice Compared with Conventional On-Equipment Troubleshooting Practice

The data reported in results and conclusions suggest that the SPT materials lend themselves to use in the troubleshooting practice just as effectively as the actual equipment. If symbolic materials were used in conjunction with the protocol records and protocol maps, an entire class could practice troubleshooting without any operational equipment. Subjects could self-score the protocol maps to compare their strategy with the optimal solution. The instructor would be required only to explain and discuss differences of approach that were unclear to the student.

Experimental and control classes should be trained in troubleshooting. The control class should be trained normally. The experimental class should use SPT materials with protocol map feedback for troubleshooting practice. Their performance should then be compared on a criterion JST and against the control class JST results.

Problem Difficulty Algorithm

As additional studies are conducted and additional materials prepared, the problem difficulty ratings should be calculated and the results compared as described in this report. Special attention should be given to the matter of algorithm sensitivity to feedback circuits.

The algorithm has a multitude of other applications such as maintainability evaluations and equipment evaluation in the context of training curriculum development.

SPT Method Applicability to Other Levels of Troubleshooting

The SPT method developed on this project can be used for any level of troubleshooting penetration. The items developed and tested on this project could be used to test or practice component level troubleshooting by simply having the subject answer with a component designator rather than a stage identification. It is possible to build SPT materials such as these to cover black box, stage or chassis, and component level repair for the cost of item development for troubleshooting to the stage level. This would seem to be a desirable feature, since troubleshooting could be taught, practiced, and tested as it is performed in the field.

It would be desirable to rerun this study for component level troubleshooting to demonstrate the applicability of the concept at this level. Extreme caution should be exercised when selecting subjects since the level of difficulty will increase and the proposed study will suffer from low overall accuracy if competent subjects are not used.

REFERENCES

- AFM 50-2. Instructional systems development. Washington, D.C.: Department of the Air Force, 1975.
- Bergman, B. A., & Siegel, A. L. Training evaluation and student achievement measurement: A review of the literature. AFHRL-TR-72-3, AD-747 040. Lowry AFB, CO: Technical Training Division, Air Force Human Resources Laboratory, January 1972.
- Boyd, J. L., Jr., & Shimberg, B. Handbook of performance testing. Princeton, NJ: Educational Testing Service, 1971.
- Cantor, J. H., & Brown, J. An evaluation of the trainer-tester and punchboard tutor as electronic troubleshooting aids. NAVTRADEVGEN 1257-2-i, AD-115 706. Port Washington, NY: Naval Training Device Center, 1956.
- Crowder, N., Morrison, E. J., & Demaree, R. G. Proficiency of Q-24 radar mechanics: VI. Analysis of intercorrelations of measures. AFPTRC-TR-54-127, AD-62 115. Lackland AFB, TX: Air Force Personnel and Training Research Center, 1954.
- Engel, J. D. Development of a work sample criterion for general vehicle mechanic. TR 70-11. Alexandria, VA: Human Resources Research Organization, 1970.
- Engel, J. D., & Rehder, R. J. A comparison of correlated-job and work-sample measures for general vehicle repairman. TR 70-16. Alexandria, VA: Human Resources Research Organization, 1970.
- Evans, R. N., & Smith, L. J. A study of performance measures of troubleshooting ability on electronic equipment. Urbana, IL: College of Education, University of Illinois, 1953.
- Fitzpatrick, R., & Morrison, E. J. Performance and product evaluation. In R. L. Thorndike (Ed.), Educational Measurement. Washington, DC: American Council on Education, 1971, 2, 237-270.
- Foley, J. P., Jr. Evaluating maintenance performance: An analysis. AFHRL-TR-74-57(I), AD-A004 761. Wright-Patterson AFB, OH: Advanced Systems Division, Air Force Human Resources Laboratory, October 1974.
- Foley, J. P., Jr. Criterion referenced measures of technical proficiency in maintenance activities. AFHRL-TR-75-61, AD-A016 420. Wright-Patterson AFB, OH: Advanced Systems Division, Air Force Human Resources Laboratory, October, 1975.

- Gagne, R. M. Problem solving and thinking. Annual Review of Psychology, 1959, 10.
- Glaser, R., Damrin, E. E., & Gardner, R. M. The tab item: A technique for the measurement of proficiency in diagnostic problem-solving tasks. Urbana, IL: Bureau of Research and Service, College of Education, University of Illinois, 1952.
- Grings, W. W., Rigney, J. W., Bond, N. A., & Summers, S. A. A methodological study of electronic troubleshooting skill: II. Intercomparisons of the MAST test, a job sample test, and ten reference tests administered to Fleet Electronics Technicians. Navy Technical Report No. 10. Los Angeles, CA: Department of Psychology, University of Southern California, 1953.
- Guilford, J. P. Fundamental statistics in psychology and education. New York: McGraw-Hill, 1956.
- Hays, W. L. Statistics for psychologists. New York: Holt, Rinehart and Winston, 1965.
- Lefkowitz, E. G. The validity of pictorial tests and their interaction with audiovisual teaching methods. SPECDEV CEN 269-7-49, AD-96 928. State College, PA: Pennsylvania State University, 1955.
- McGuire, C. H., & Babbott, D. Simulation technique in the measurement of problem solving skills. Journal of Educational Measurement, 1967, 4, 1-10.
- McGuire, C. H., Solomon, L. M., & Bashook, P. G. Construction and use of written simulations. Chicago, IL: Psychological Corporation, 1976.
- Naval Training Device Center. Utilization guide for study card sets. NAVEXOS P-2167, Port Washington, NY: Author, 1960.
- Osborn, W. C. An approach to the development of synthetic performance tests for use in training evaluation. PP 30-70. Alexandria, VA: Human Resources Research Organization, 1970.
- Shriver, E. L., & Foley, J. P., Jr. Evaluating maintenance performance: The development of graphic symbolic substitutes for criterion referenced job task performance tests for electronic maintenance. AFHRL-TR-74-57 (III), AD-A005 296. Wright-Patterson AFB, OH: Advanced Systems Division, Air Force Human Resources Laboratory, November 1974.
- Siegel, A. L., Bergman, B. A., Federman, P., & Sellman, W. S. Some techniques for the evaluation of technical training courses and students. AFHRL-TR-72-15, AD-753 094. Lowry AFB, CO: Technical Training Division, Air Force Human Resources Laboratory, 1972.

Thorndike, R. L. Personnel selection. New York: John Wiley & Sons, Inc., 1949.

Vineberg, R., Taylor, E. N., Young, D. L., Hirshfeld, S. F., & Maier, M. H. Manual for developing skill qualification tests. Alexandria, VA: Human Resources Research Organization, 1976.

APPENDIX A
SPT SAMPLE PROBLEMS

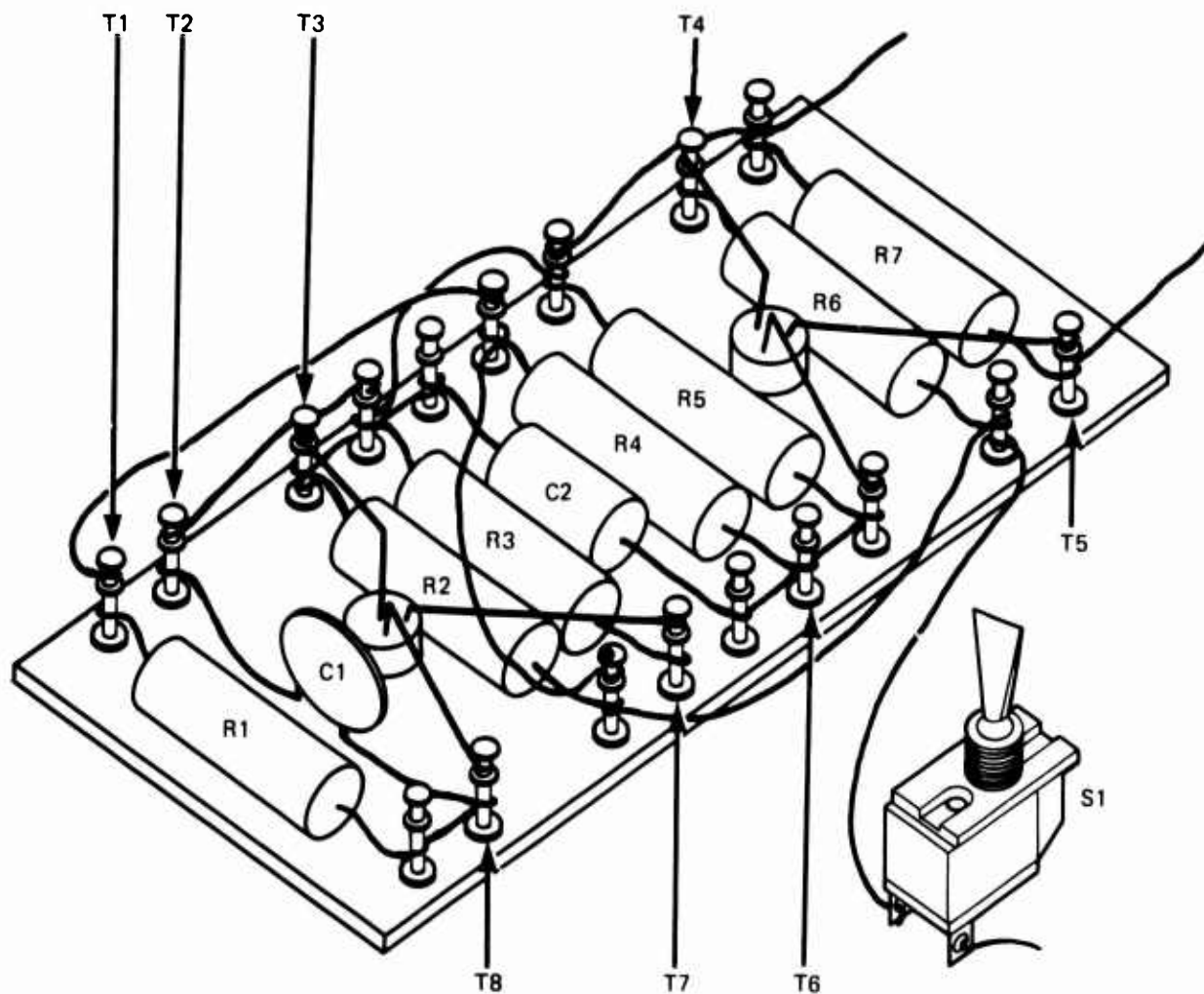

SYMBOLIC PERFORMANCE TEST
 SAMPLE PROBLEM
 LOCATOR ART

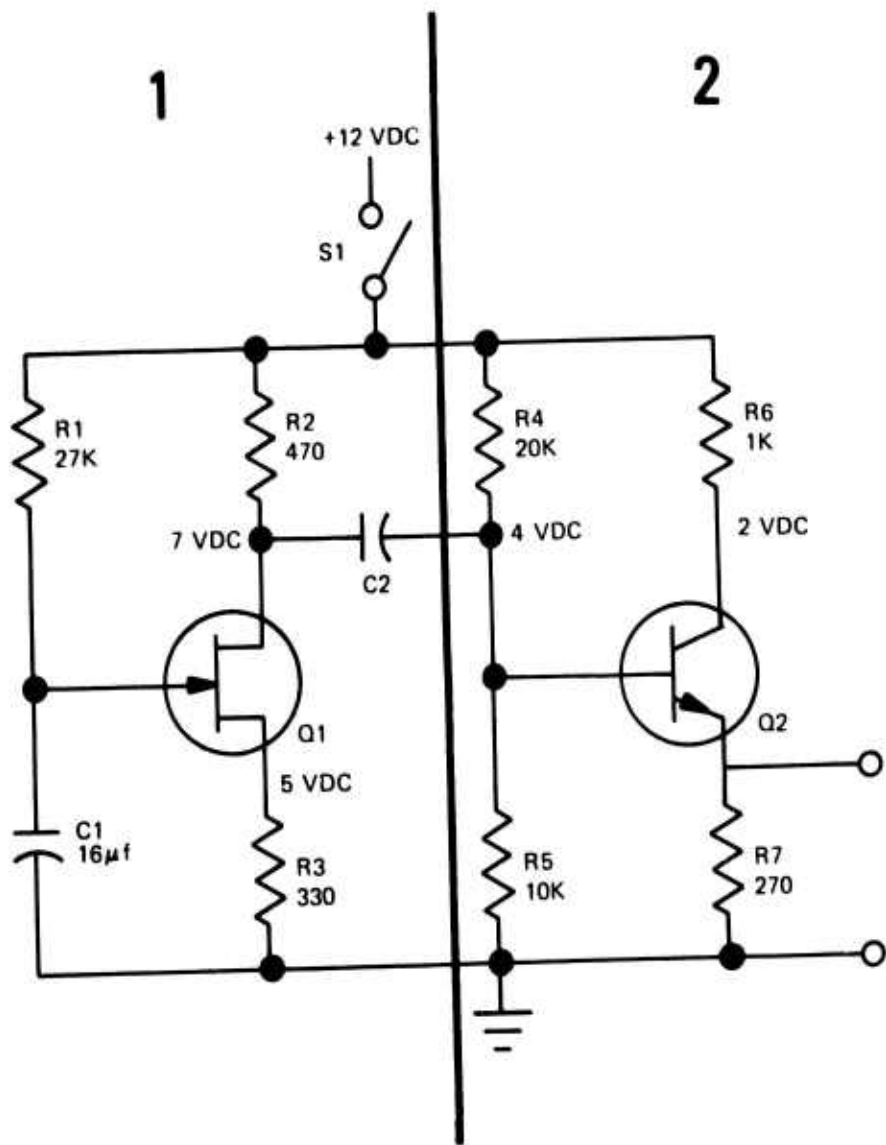

SYMBOLIC PERFORMANCE TEST
 SAMPLE PROBLEM
 SCHEMATIC (TECHNICAL DATA)

SAMPLE PROBLEM 1

POINT OF TEST/SYSTEM STATE CONVERSION TABLE

	S1 OFF	S1 ON				
POINT OF TEST I.D.	GUIDE NOS.	GUIDE NOS.	GUIDE NOS.	GUIDE NOS.	GUIDE NOS.	GUIDE NOS.
T1	S1	S2				
T2	S3	S4				
T3	S5	S6				
T4	S7	S8				
T5	S9	S10				
T6	S11	S12				
T7	S13	S14				
T8	S15	S16				

SAMPLE PROBLEM 1

VOLTMETER CONVERSION TABLE: AC

SYSTEM STATE GUIDE NUMBER	19	20	21	22	23	24
S1	V20	V20	V20	V20	V20	V20
S2	V20	V20	V20	V20	V20	V20
S3	V20	V20	V20	V20	V20	V20
S4	V20	V20	V20	V20	V20	V20
S5	V20	V20	V20	V20	V20	V20
S6	V4	V4	V4	V5	V2	V8
S7	V20	V20	V20	V20	V20	V20
S8	V20	V20	V20	V20	V20	V20
S9	V20	V20	V20	V20	V20	V20
S10	V20	V20	V20	V20	V20	V20
S11	V20	V20	V20	V20	V20	V20
S12	V4	V4	V5	V2	V8	V20
S13	V20	V20	V20	V20	V20	V20
S14	V4	V4	V4	V5	V2	V8
S15	V20	V20	V20	V20	V20	V20
S16	V4	V4	V5	V2	V8	V20

SAMPLE PROBLEM 1

VOLTMETER CONVERSION TABLE: DC+

SYSTEM STATE GUIDE NUMBER	7	8	9	10	11	12
S1	V20	V20	V20	V20	V20	V20
S2	V4	V4	V4	V18	V7	V12
S3	V20	V20	V20	V20	V20	V20
S4	V20	V20	V20	V20	V20	V20
S5	V20	V20	V20	V20	V20	V20
S6	V4	V4	V4	V23	V2	V8
S7	V20	V20	V20	V20	V20	V20
S8	V4	V4	V4	V18	V7	V12
S9	V20	V20	V20	V20	V20	V20
S10	V20	V20	V20	V20	V20	V20
S11	V20	V20	V20	V20	V20	V20
S12	V20	V20	V20	V20	V20	V20
S13	V20	V20	V20	V20	V20	V20
S14	V4	V4	V4	V22	V2	V8
S15	V20	V20	V20	V20	V20	V20
S16	V4	V4	V4	V5	V2	V8

SAMPLE PROBLEM 1

VOLTMETER CONVERSION TABLE: OHMS

POINTS OF TEST		25	26	27	28	29	30
COM	DCA OHMS						
T1	T3	V4	V6	V22	V8	V20	V20
T1	T6	V4	V4	V4	V4	V4	V4
T1	T4	V4	V23	V12	V20	V20	V20
T1	T8	V4	V4	V17	V16	V20	V20
T2	T5	V17	V16	V20	V20	V20	V20
T2	T6	V4	V4	V23	V12	V20	V20
T2	T7	V18	V7	V20	V20	V20	V20
T2	T8	V4	V4	V4	V4	V4	V4
T3	T1	V4	V6	V22	V8	V20	V20
T3	T6	V4	V4	V4	V4	V4	V4
T3	T7	V4	V4	V4	V4	V4	V4
T3	T8	V1	V25	V8	V20	V20	V20
T4	T1	V4	V23	V12	V20	V20	V20
T4	T5	V4	V4	V4	V13	V25	V20
T4	T6	V4	V10	V7	V20	V20	V20
T5	T2	V17	V16	V20	V20	V20	V20
T5	T4	V20	V20	V20	V20	V20	V20
T5	T6	V4	V10	V7	V20	V20	V20
T6	T1	V4	V4	V4	V4	V4	V4
T6	T3	V4	V4	V4	V4	V4	V4
T6	T4	V4	V4	V4	V4	V4	V4
T6	T5	V4	V4	V4	V13	V25	V20
T7	T2	V18	V7	V20	V20	V20	V20
T7	T3	V4	V4	V4	V4	V4	V4
T7	T8	V1	V25	V8	V20	V20	V20
T8	T1	V4	V4	V17	V16	V20	V20
T8	T2	V4	V4	V4	V4	V4	V4
T8	T3	V4	V4	V22	V8	V20	V20
T8	T7	V4	V4	V22	V8	V20	V20

SAMPLE PROBLEM 1

SCOPE CONVERSION TABLE

SYSTEM STATE GUIDE NUMBER	31	32				
S1	09	09				
S2	07	08				
S3	09	09				
S4	09	09				
S5	09	09				
S6	05	02				
S7	09	09				
S8	07	08				
S9	09	09				
S10	09	09				
S11	09	09				
S12	05	02				
S13	09	09				
S14	03	06				
S15	09	09				
S16	01	04				

SAMPLE PROBLEM 2

POINT OF TEST/SYSTEM STATE CONVERSION TABLE

	S1 OFF	S1 ON				
POINT OF TEST I.D.	GUIDE NOS.	GUIDE NOS.	GUIDE NOS.	GUIDE NOS.	GUIDE NOS.	GUIDE NOS.
T1	S1	S2				
T2	S3	S4				
T3	S5	S6				
T4	S7	S8				
T5	S9	S10				
T6	S11	S12				
T7	S13	S14				
T8	S15	S16				

SAMPLE PROBLEM 2

VOLTMETER CONVERSION TABLE: AC

SYSTEM STATE GUIDE NUMBER	19	20	21	22	23	24
S1	V20	V20	V20	V20	V20	V20
S2	V20	V20	V20	V20	V20	V20
S3	V20	V20	V20	V20	V20	V20
S4	V20	V20	V20	V20	V20	V20
S5	V20	V20	V20	V20	V20	V20
S6	V20	V20	V20	V20	V20	V20
S7	V20	V20	V20	V20	V20	V20
S8	V20	V20	V20	V20	V20	V20
S9	V20	V20	V20	V20	V20	V20
S10	V20	V20	V20	V20	V20	V20
S11	V20	V20	V20	V20	V20	V20
S12	V20	V20	V20	V20	V20	V20
S13	V20	V20	V20	V20	V20	V20
S14	V20	V20	V20	V20	V20	V20
S15	V20	V20	V20	V20	V20	V20
S16	V20	V20	V20	V20	V20	V20

SAMPLE PROBLEM 2

VOLTMETER CONVERSION TABLE: DC+

SYSTEM STATE GUIDE NUMBER	7	8	9	10	11	12
S1	V20	V20	V20	V20	V20	V20
S2	V4	V4	V4	V18	V7	V12
S3	V20	V20	V20	V20	V20	V20
S4	V20	V20	V20	V20	V20	V20
S5	V20	V20	V20	V20	V20	V20
S6	V4	V4	V4	V18	V7	V12
S7	V20	V20	V20	V20	V20	V20
S8	V4	V4	V5	V2	V8	V20
S9	V20	V20	V20	V20	V20	V20
S10	V20	V20	V20	V20	V20	V20
S11	V20	V20	V20	V20	V20	V20
S12	V4	V4	V18	V19	V12	V8
S13	V20	V20	V20	V20	V20	V20
S14	V4	V4	V4	V18	V7	V12
S15	V20	V20	V20	V20	V20	V20
S16	V4	V4	V4	V18	V7	V12

SAMPLE PROBLEM 2

VOLTMETER CONVERSION TABLE: OHMS

POINTS OF TEST		25	26	27	28	29	30
COM	DCA OHMS						
T1	T3	V4	V6	V22	V8	V20	V20
T1	T6	V4	V4	V4	V1	V12	V20
T1	T4	V4	V23	V12	V20	V20	V20
T1	T8	V4	V4	V17	V16	V20	V20
T2	T5	V17	V16	V20	V20	V20	V20
T2	T6	V4	V4	V23	V12	V20	V20
T2	T7	V4	V4	V4	V4	V4	V4
T2	T8	V4	V4	V4	V4	V4	V4
T3	T1	V4	V6	V22	V8	V20	V20
T3	T6	V4	V4	V4	V4	V4	V4
T3	T7	V4	V4	V4	V4	V4	V4
T3	T8	V1	V25	V8	V20	V20	V20
T4	T1	V4	V23	V12	V20	V20	V20
T4	T5	V4	V4	V4	V13	V25	V20
T4	T6	V4	V10	V7	V20	V20	V20
T5	T2	V17	V16	V20	V20	V20	V20
T5	T4	V20	V20	V20	V20	V20	V20
T5	T6	V4	V10	V7	V20	V20	V20
T6	T1	V4	V4	V4	V1	V12	V20
T6	T3	V4	V4	V4	V4	V4	V4
T6	T4	V4	V4	V4	V4	V4	V4
T6	T5	V4	V4	V4	V13	V25	V20
T7	T2	V4	V4	V4	V4	V4	V4
T7	T3	V4	V4	V4	V4	V4	V4
T7	T8	V1	V25	V8	V20	V20	V20
T8	T1	V4	V4	V17	V16	V20	V20
T8	T2	V4	V4	V4	V4	V4	V4
T8	T3	V4	V4	V22	V8	V20	V20
T8	T7	V4	V4	V22	V8	V20	V20

SAMPLE PROBLEM 2

SCOPE CONVERSION TABLE

SYSTEM STATE GUIDE NUMBER	31	32				
S1	09	09				
S2	09	09				
S3	09	09				
S4	09	09				
S5	09	09				
S6	09	09				
S7	09	09				
S8	09	09				
S9	09	09				
S10	09	09				
S11	09	09				
S12	09	09				
S13	09	09				
S14	09	09				
S15	09	09				
S16	09	09				

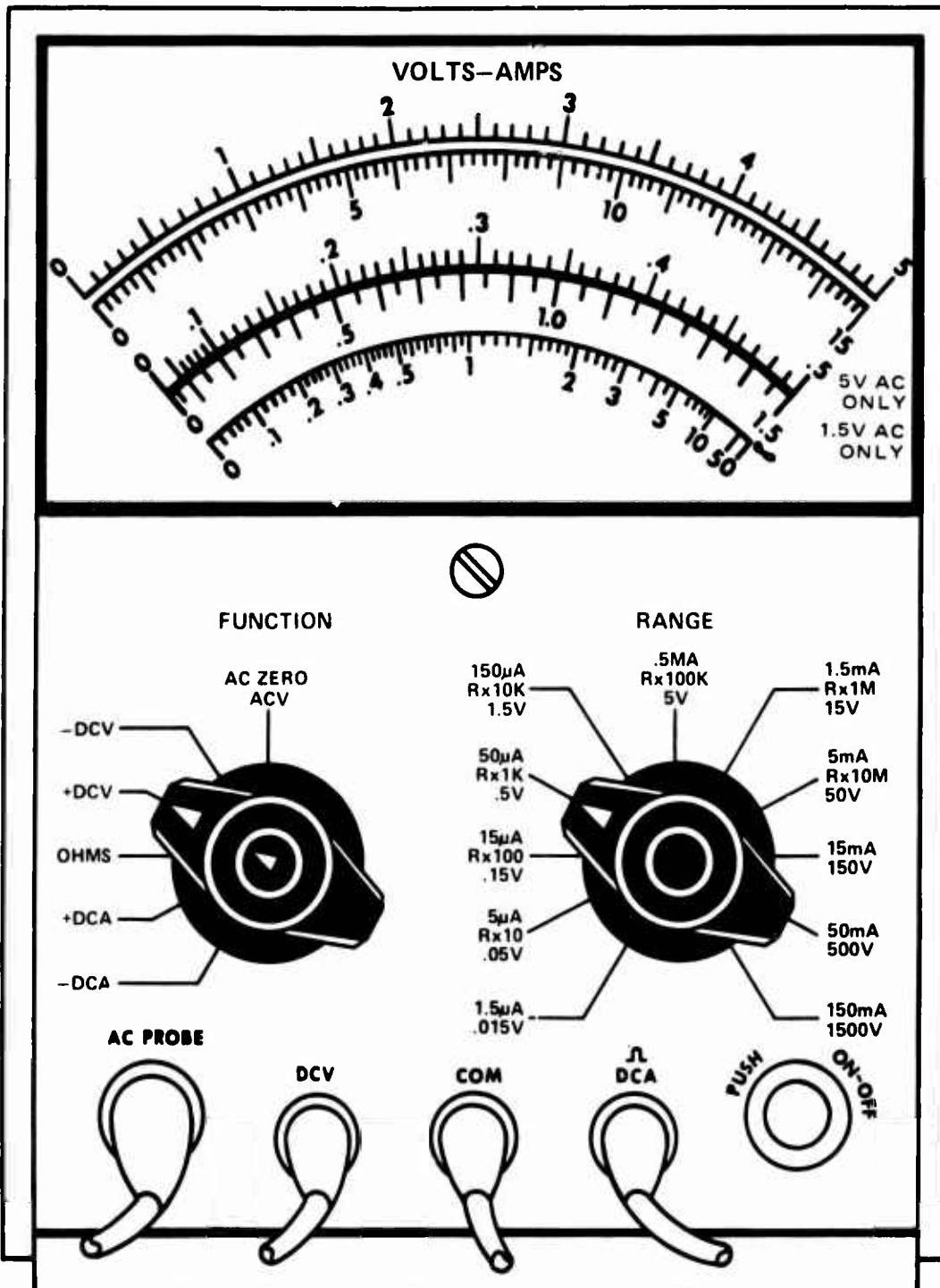

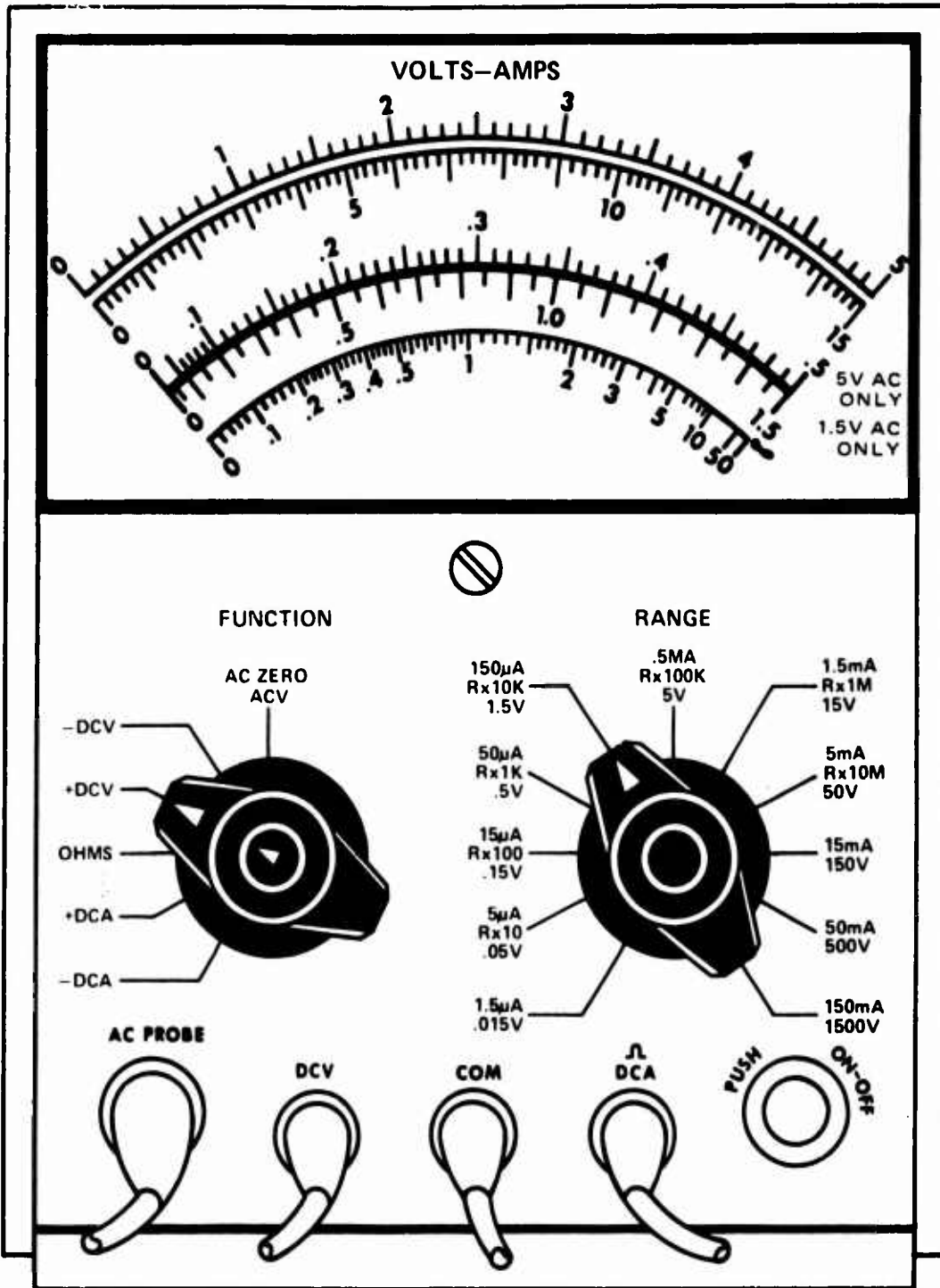

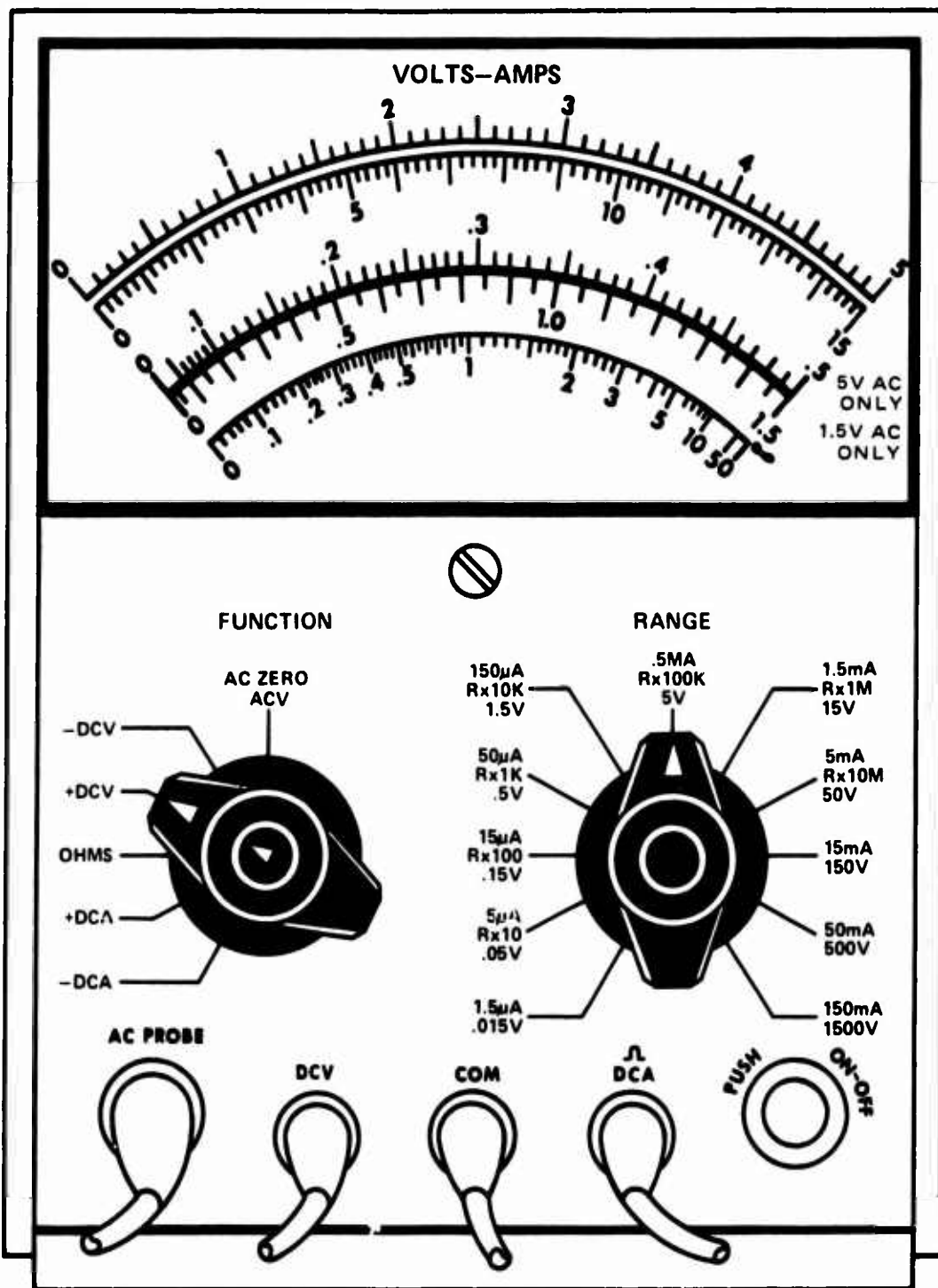

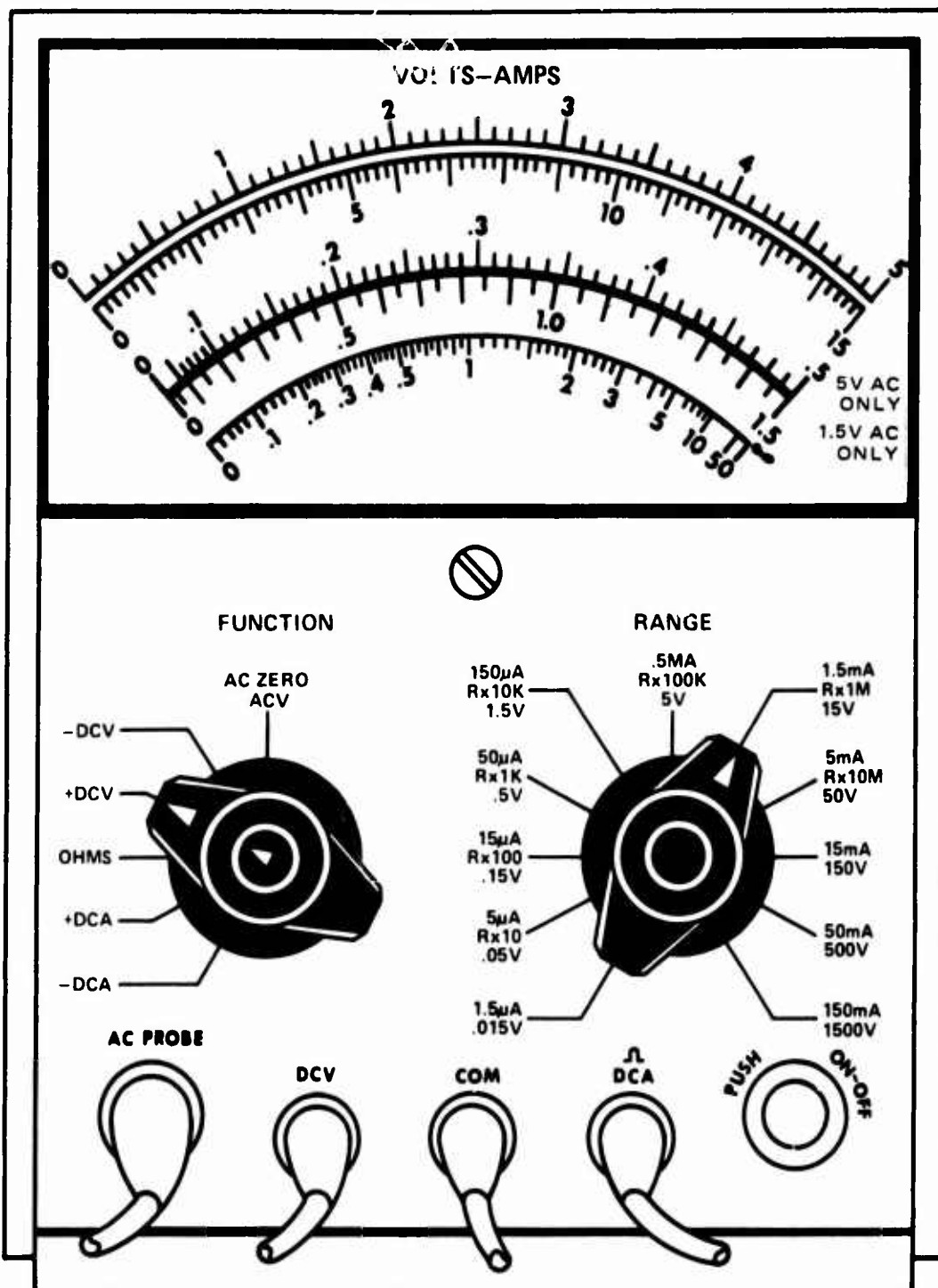

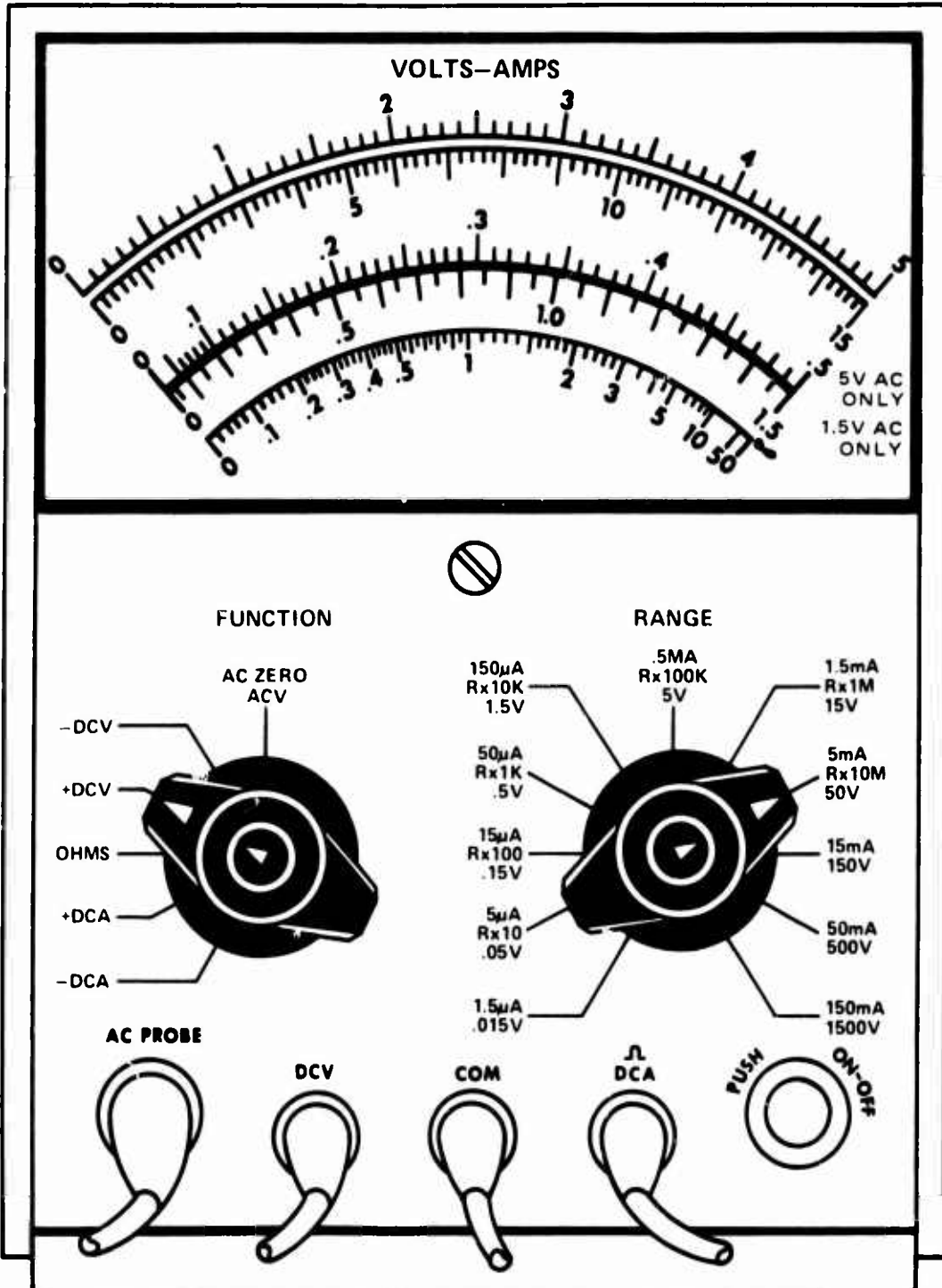

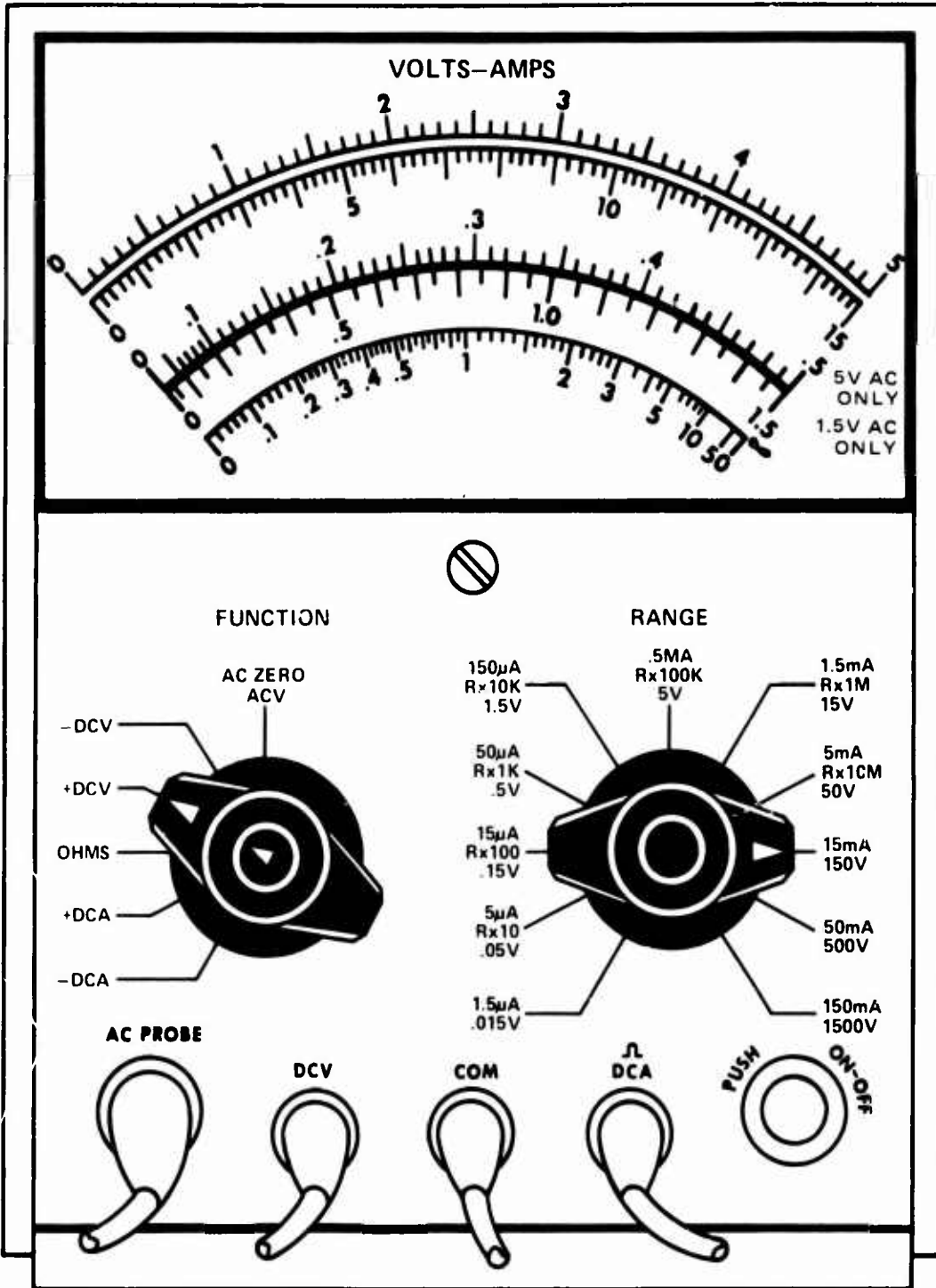

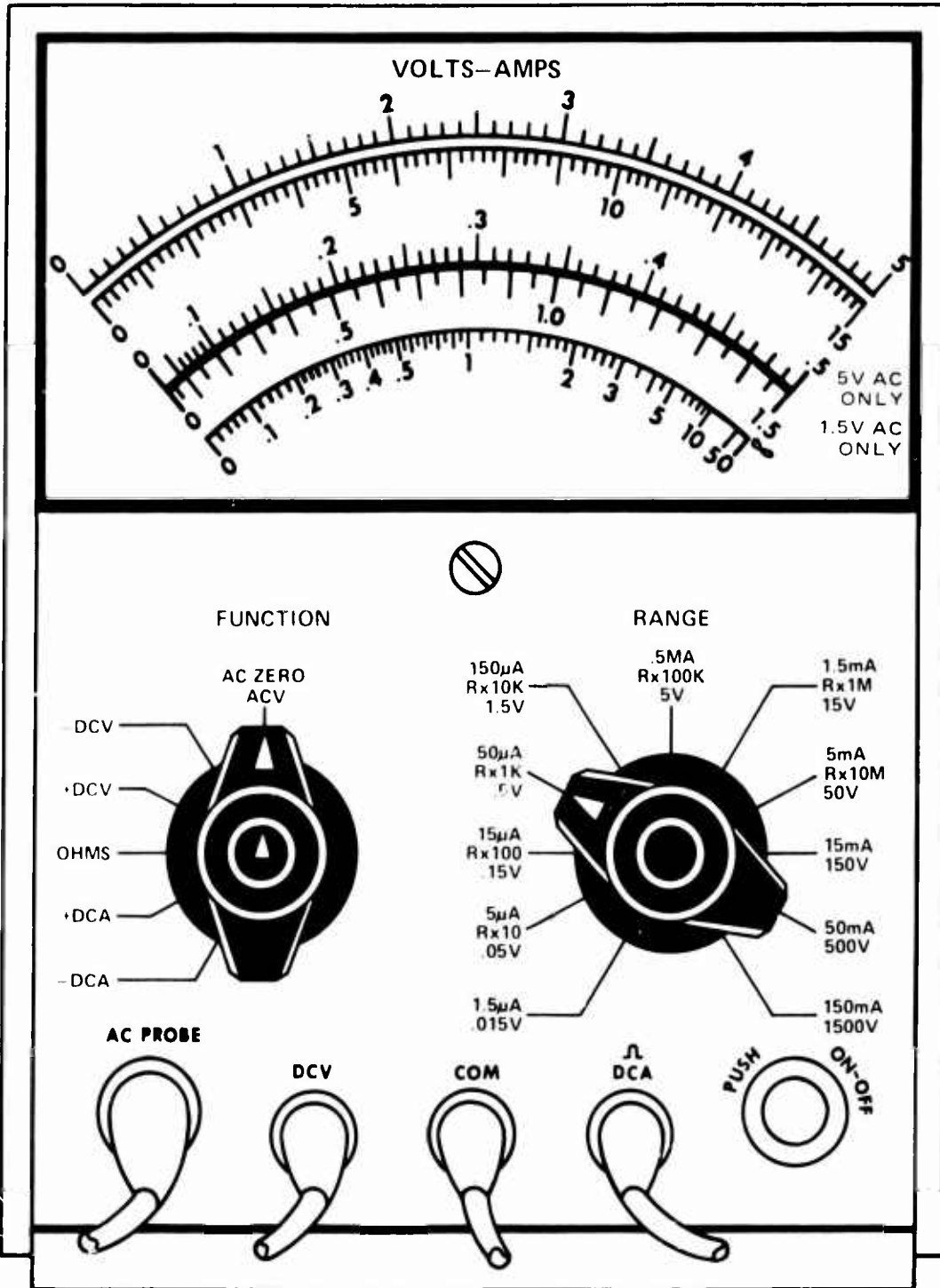

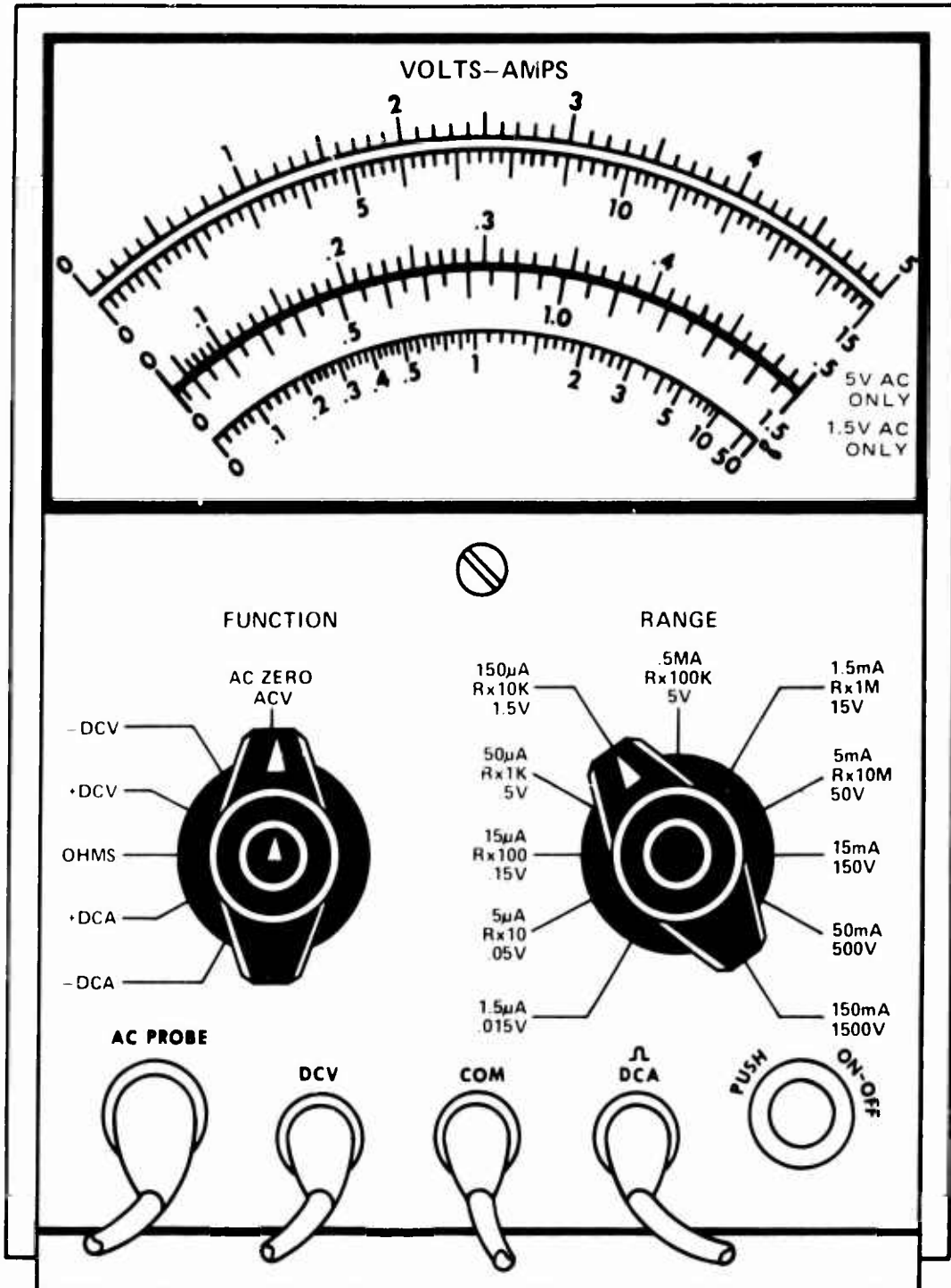

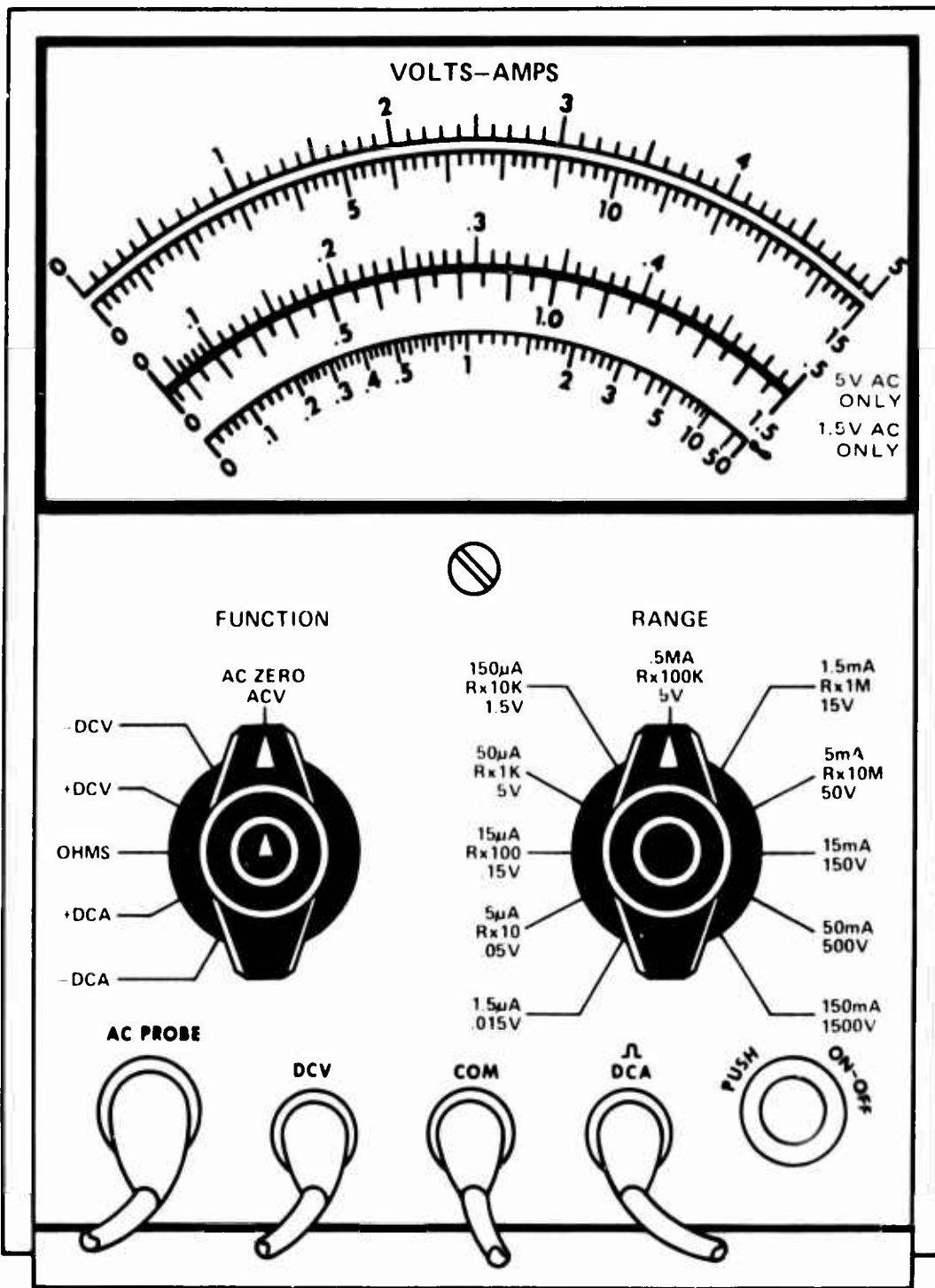

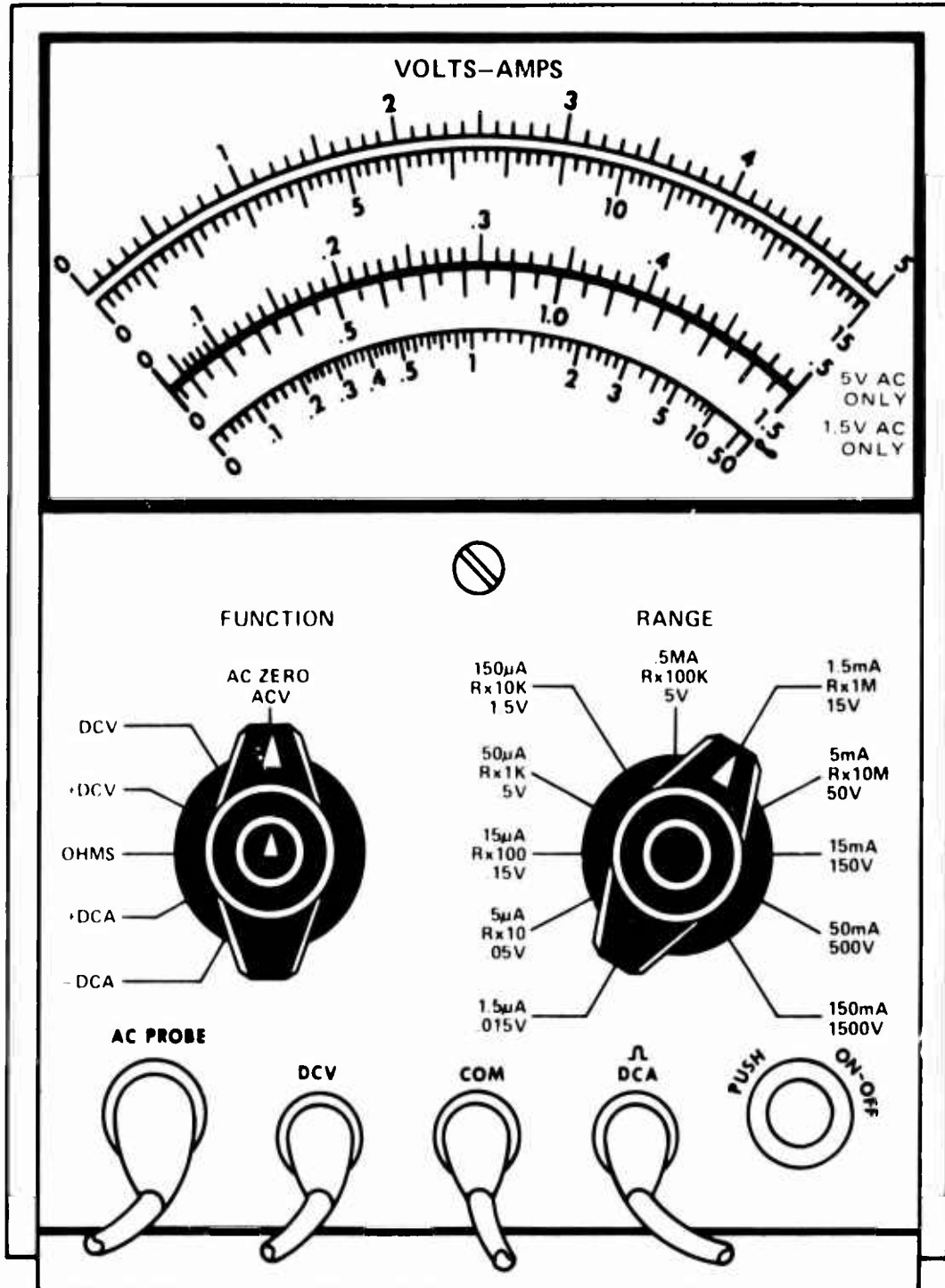

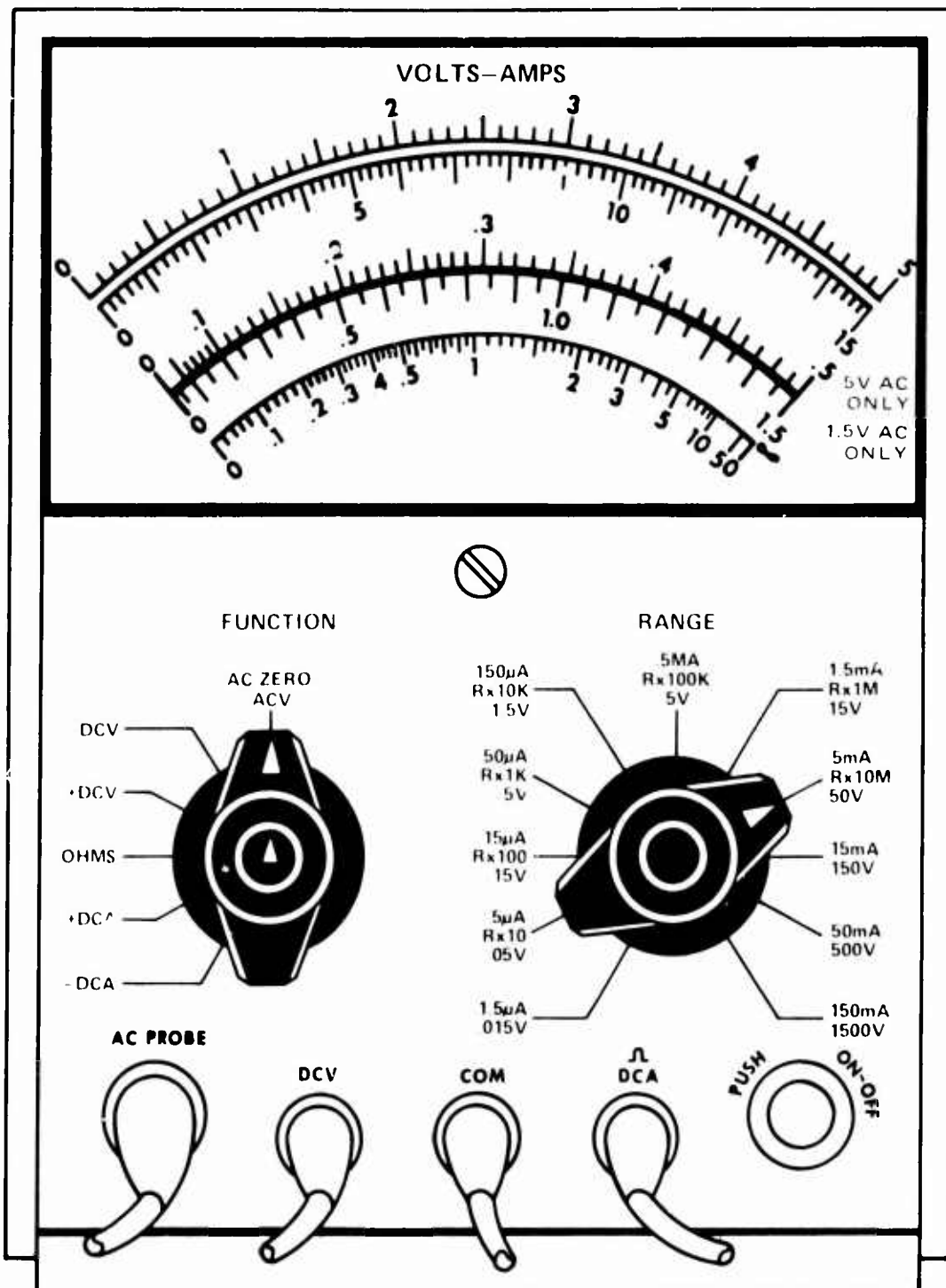

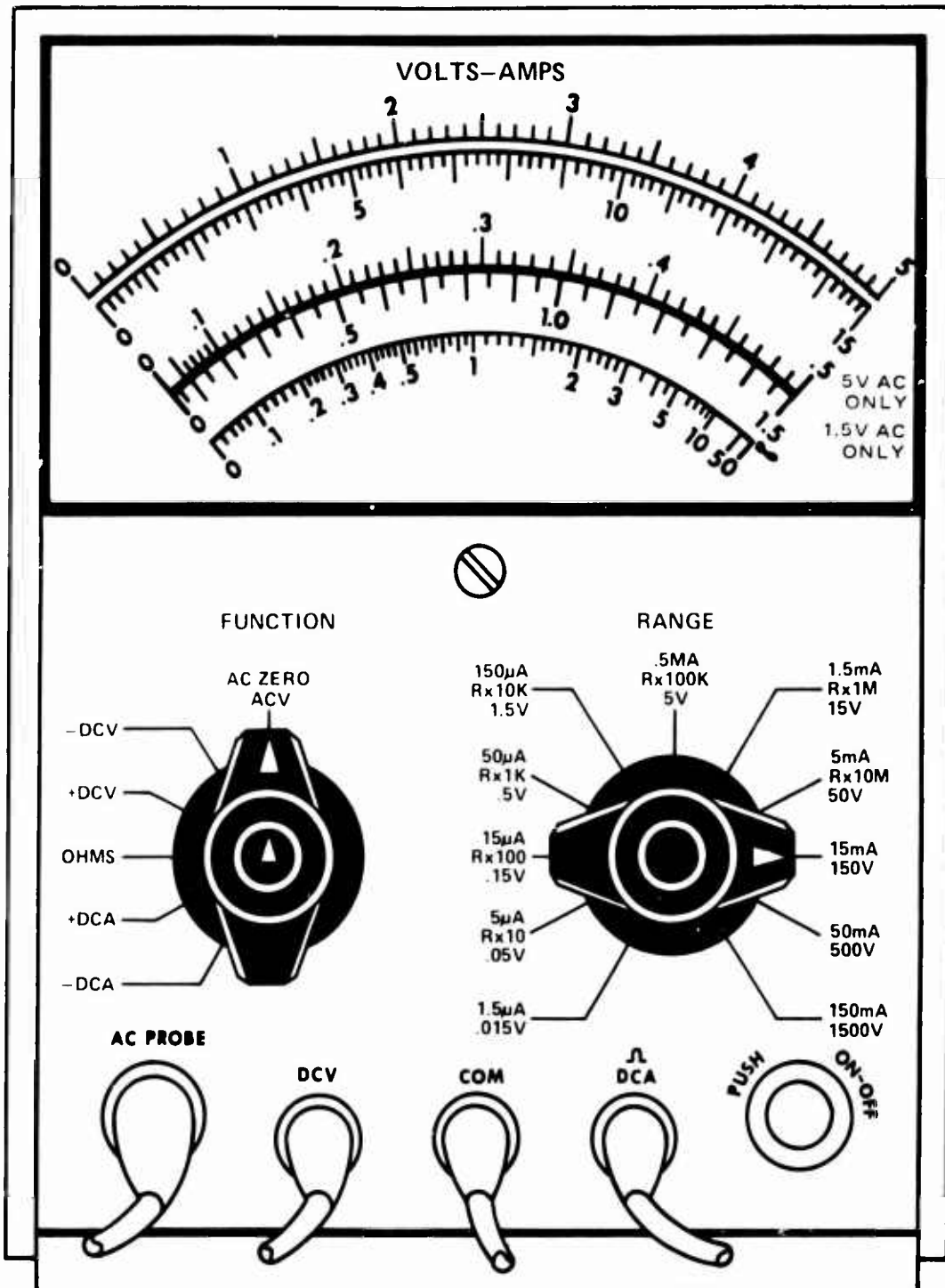

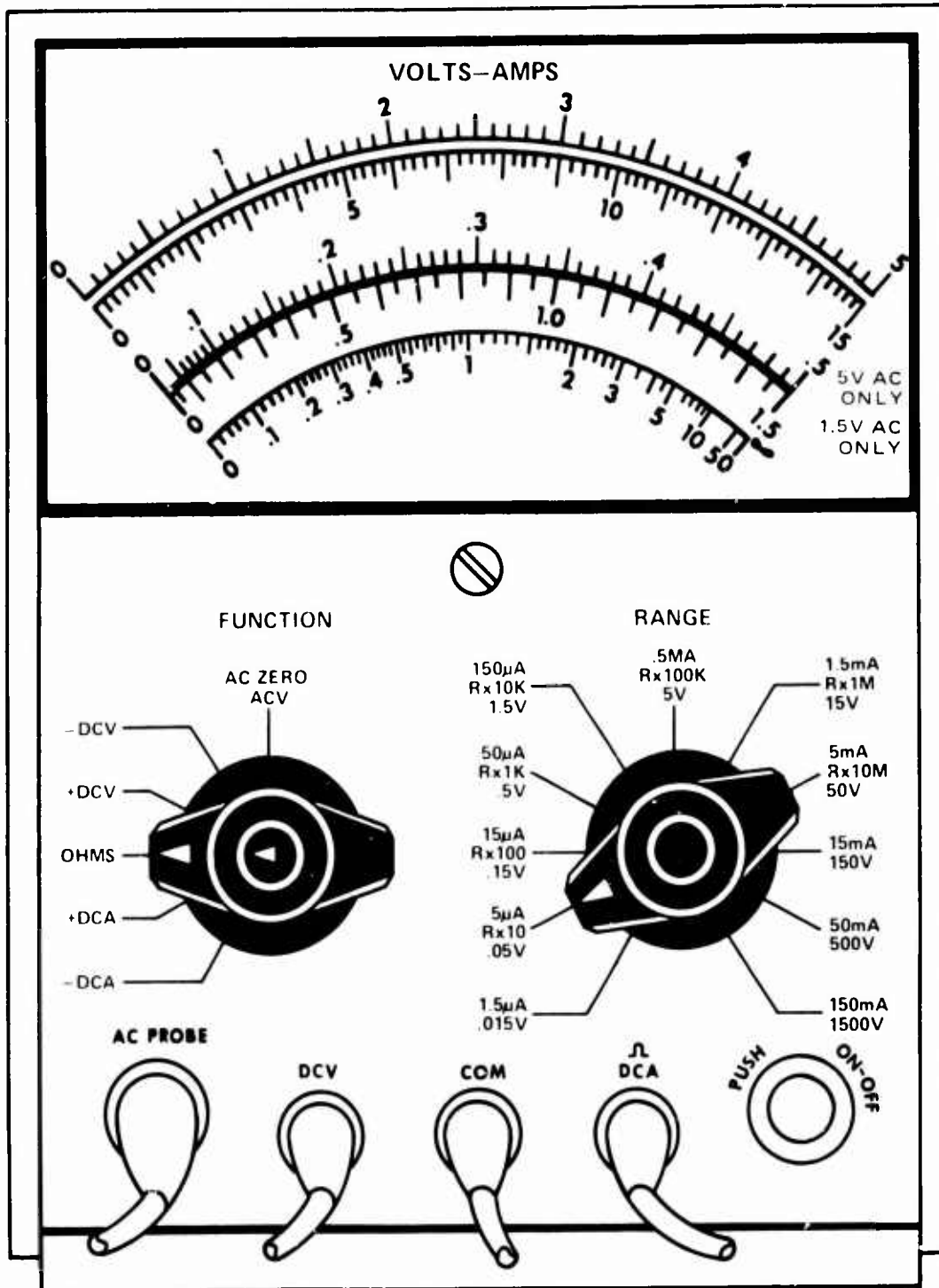

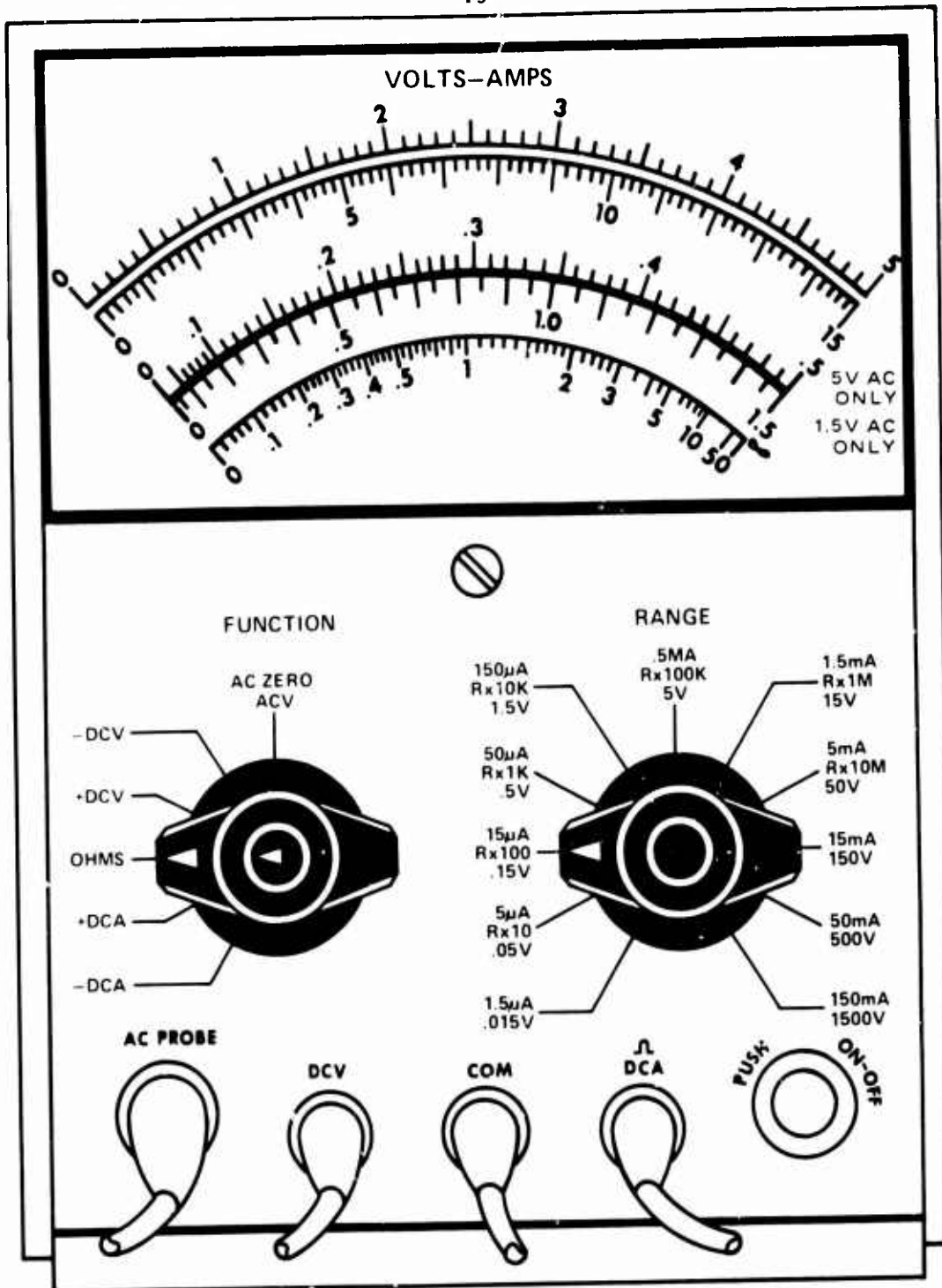

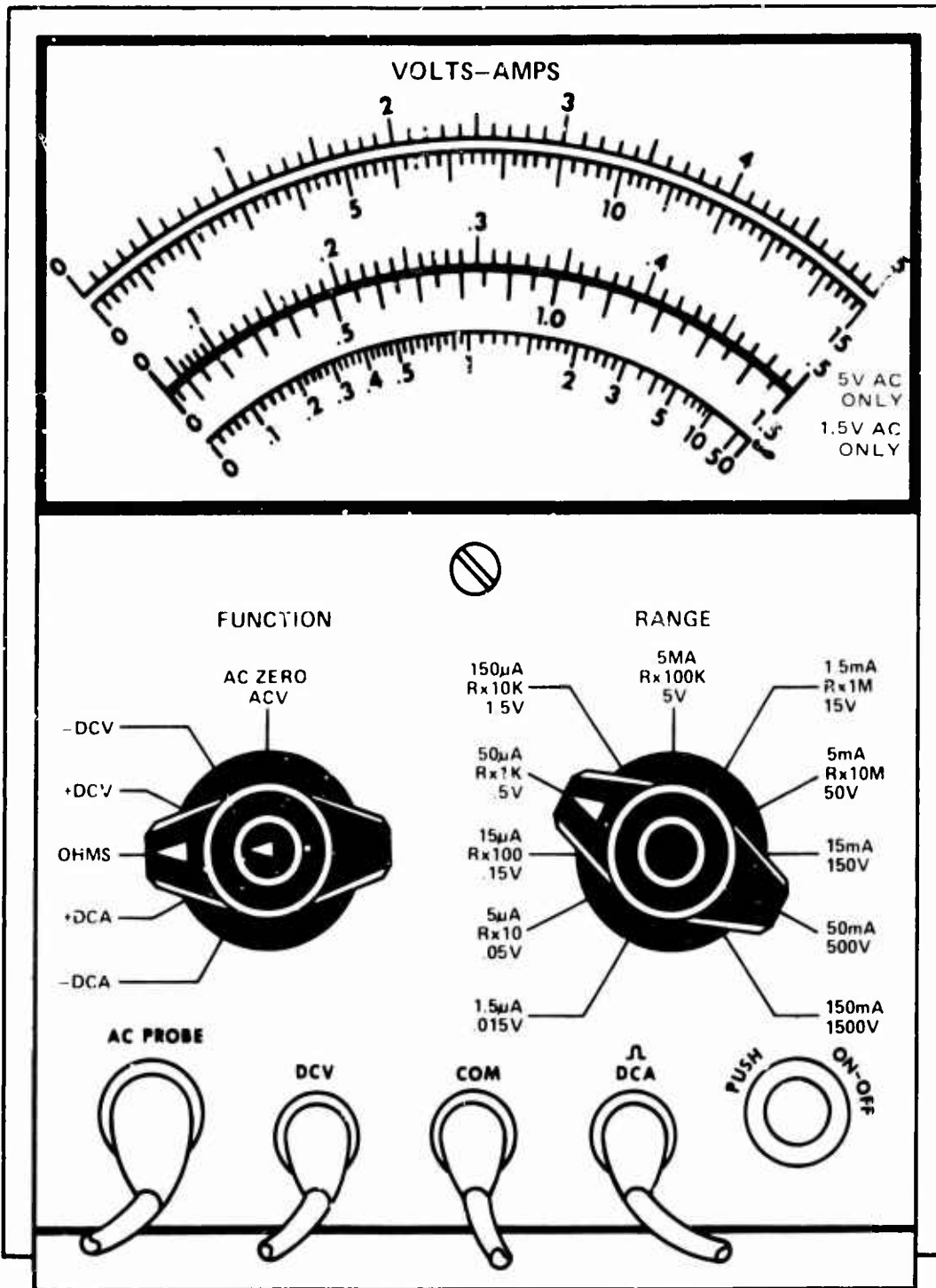

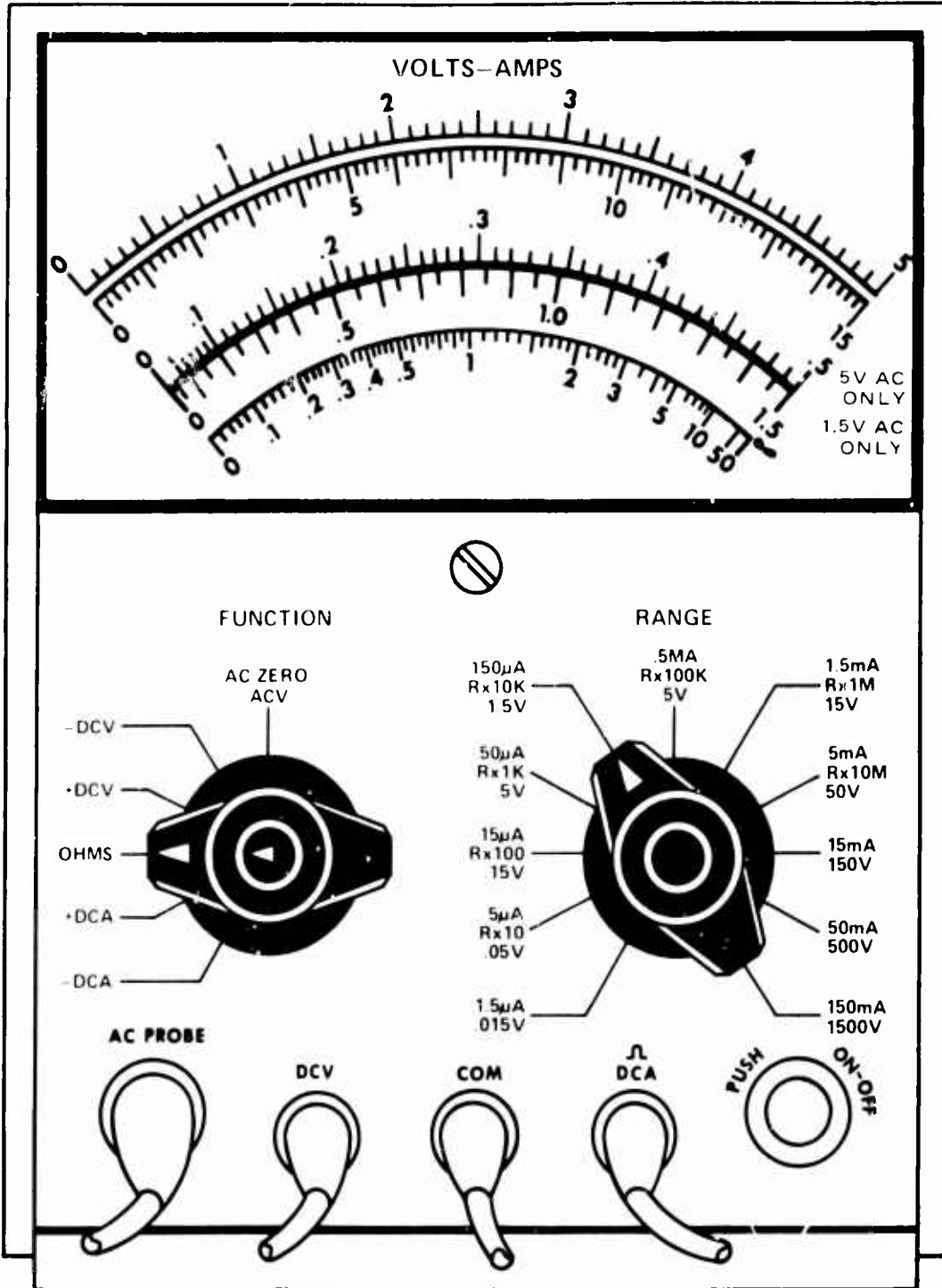

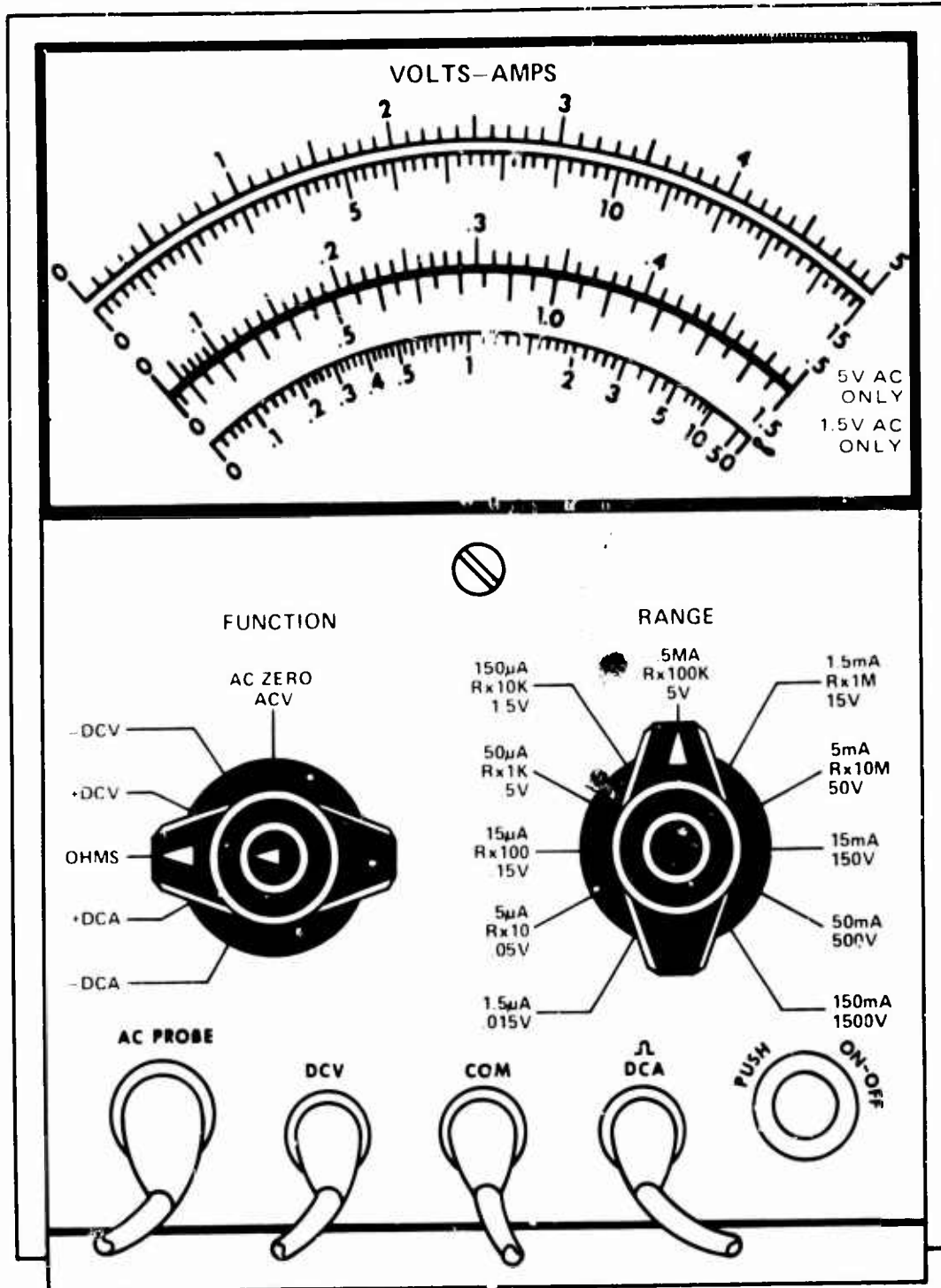

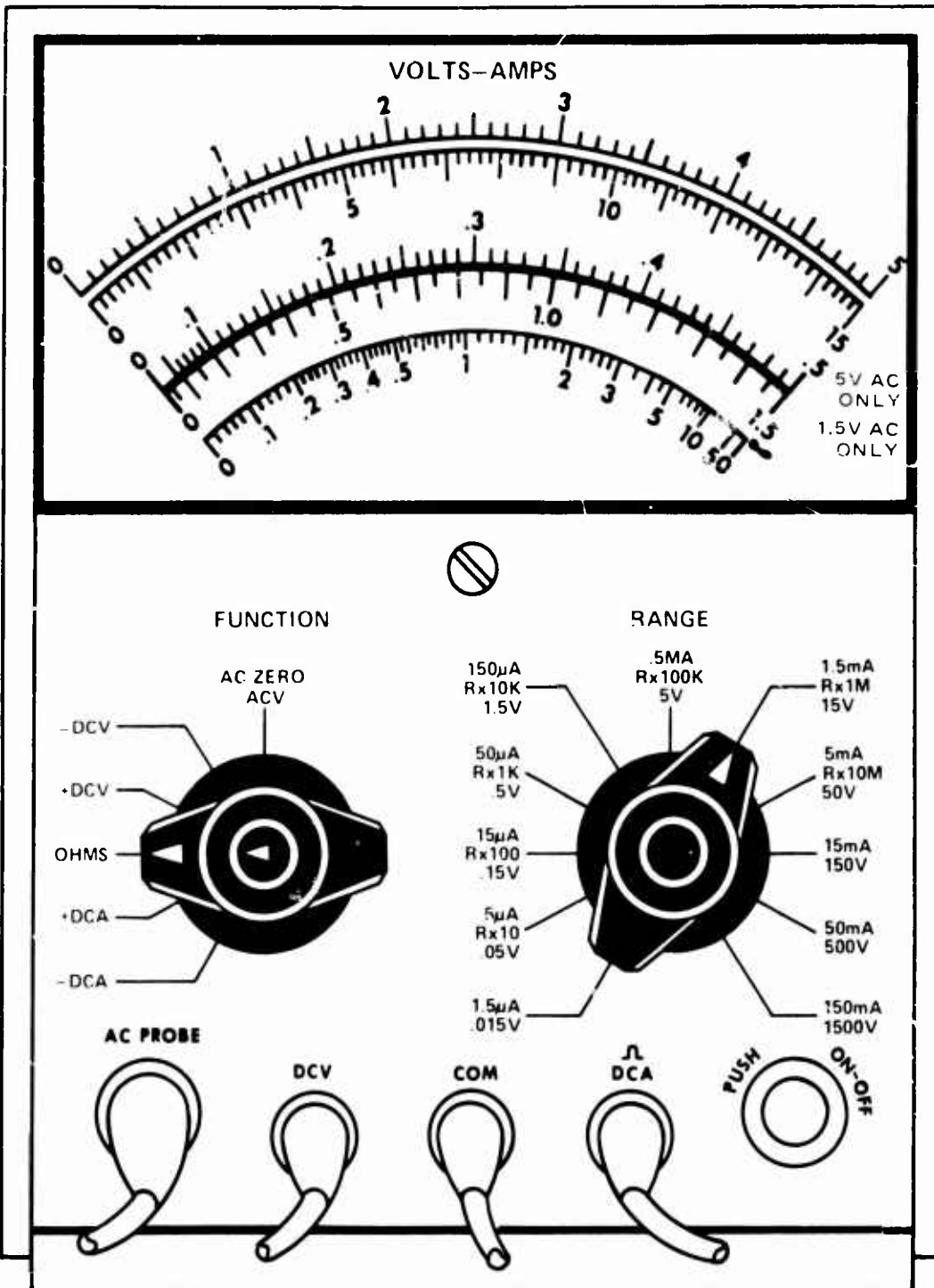

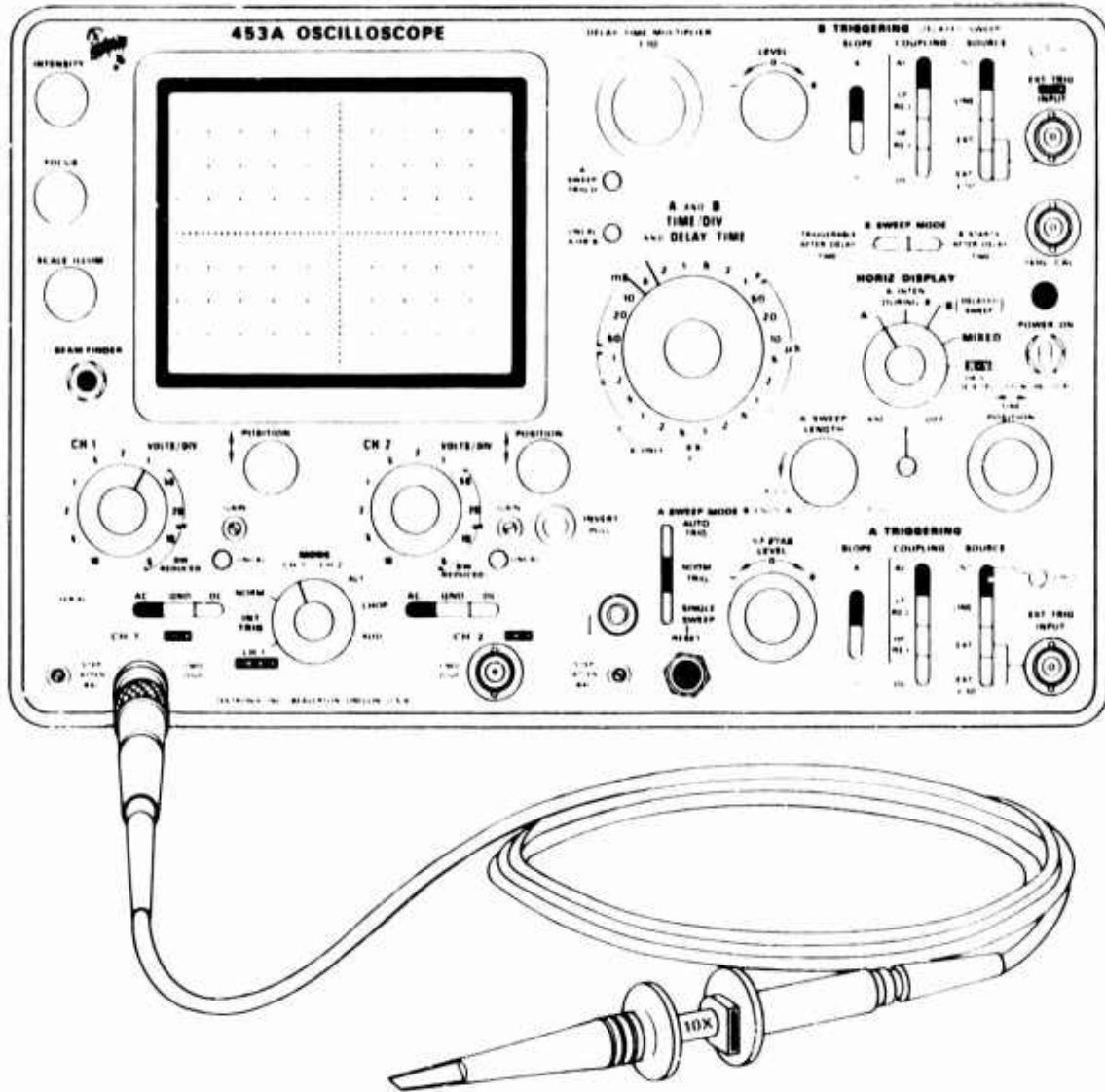

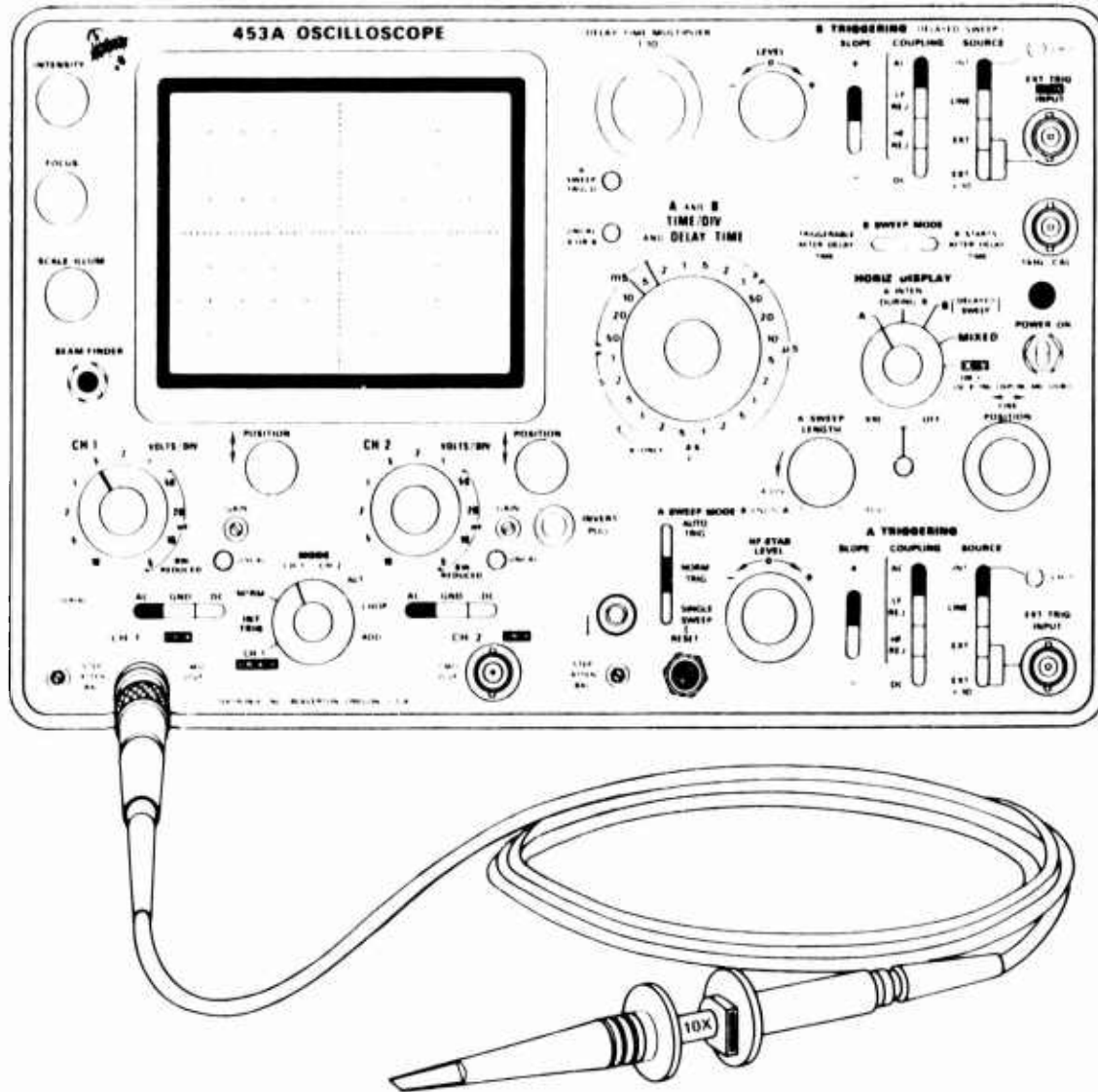

GUIDE NO. V1

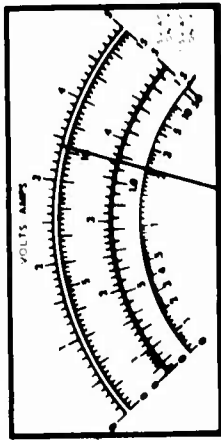

GUIDE NO. V2

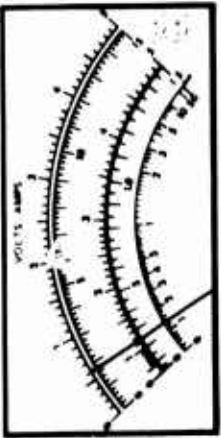

GUIDE NO. V3

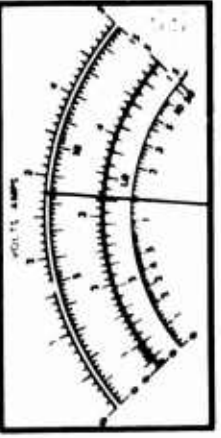

GUIDE NO. V4

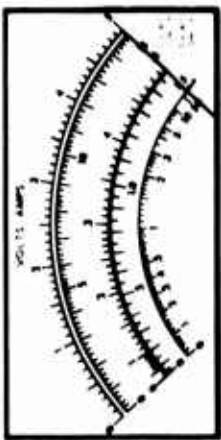

GUIDE NO. V5

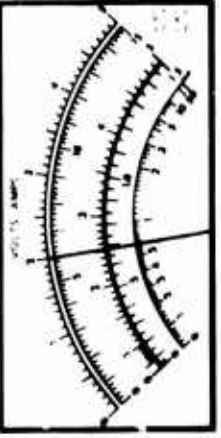

GUIDE NO. V6

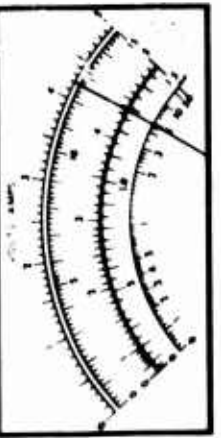

GUIDE NO. V7

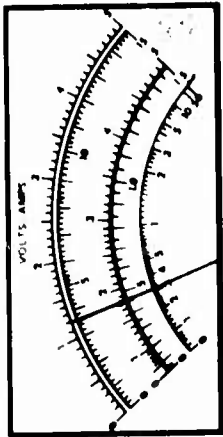

GUIDE NO. V8

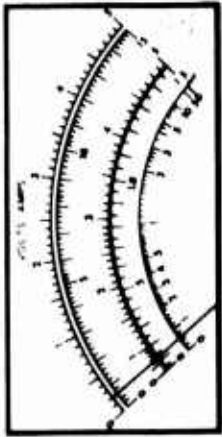

GUIDE NO. V11

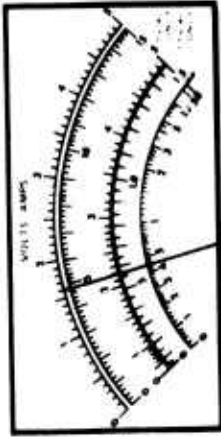

GUIDE NO. V14

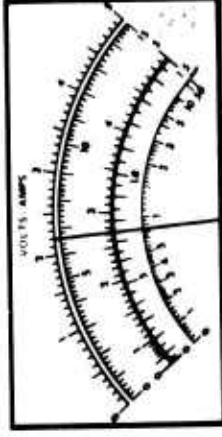

GUIDE NO. V17

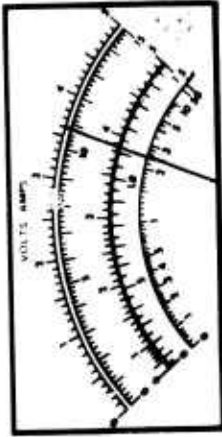

GUIDE NO. V10

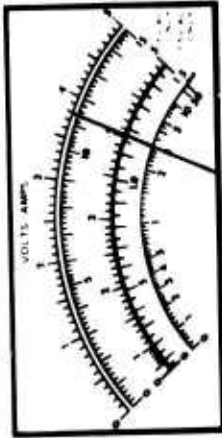

GUIDE NO. V13

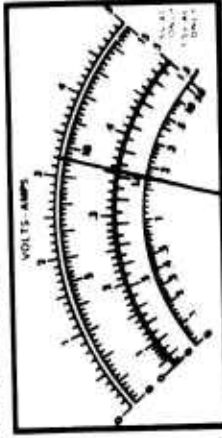

GUIDE NO. V16

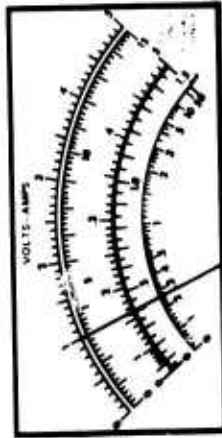

GUIDE NO. V9

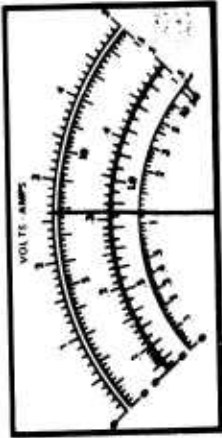

GUIDE NO. V12

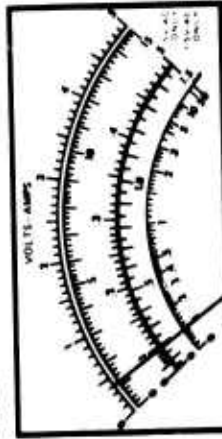

GUIDE NO. V15

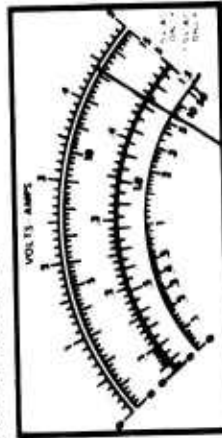

GUIDE NO. V18

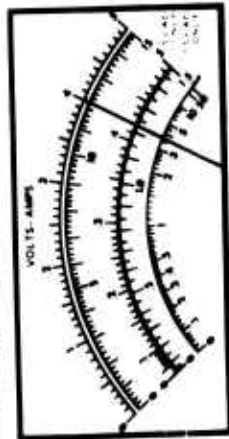

GUIDE NO. V19

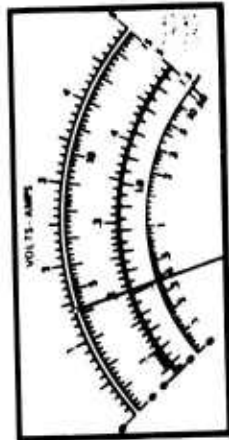

GUIDE NO. V20

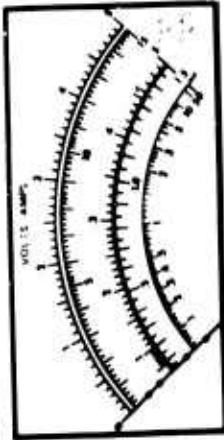

GUIDE NO. V21

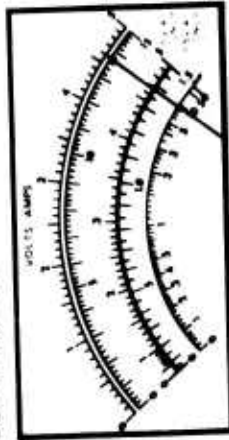

GUIDE NO. V22

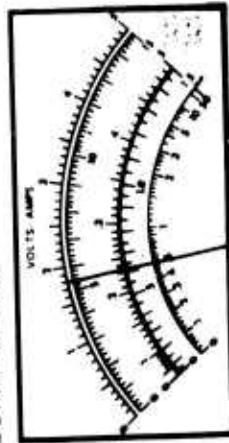

GUIDE NO. V23

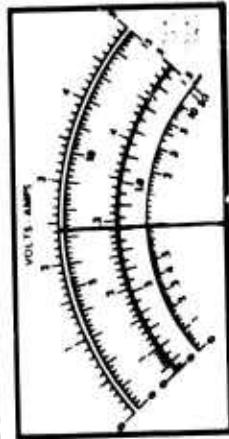

GUIDE NO. V24

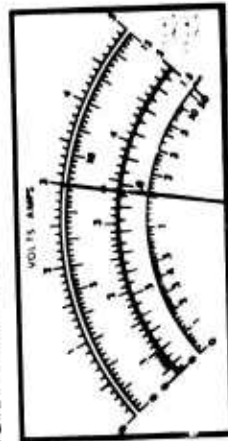

GUIDE NO. V25

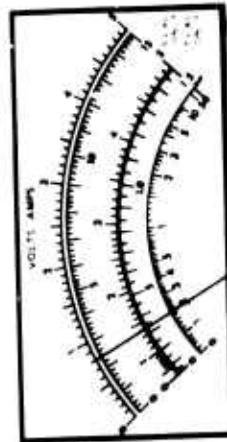

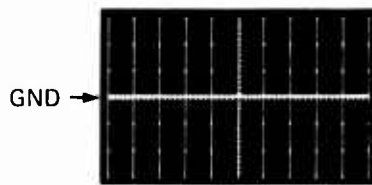
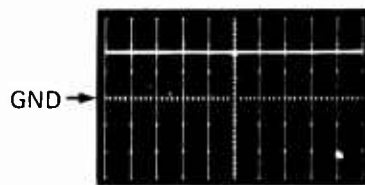
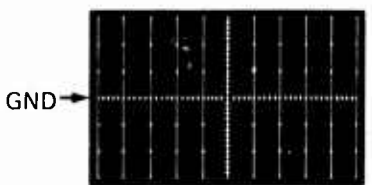
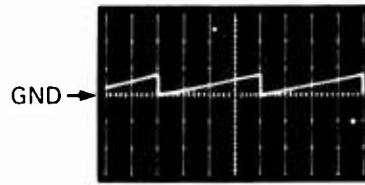
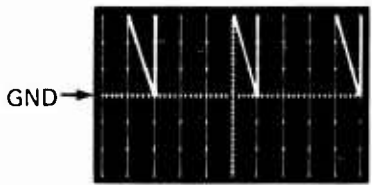
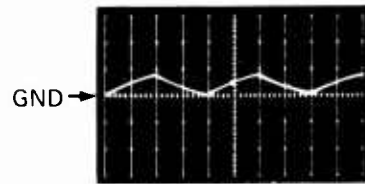
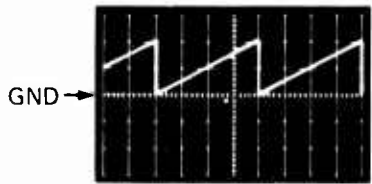
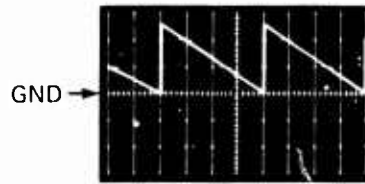
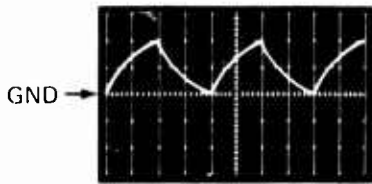

APPENDIX B
ACCURACY RAW DATA

SUBJECT	OSCILLATOR						SCOPE							
	1	2	3	JST	SPT		1	2	3	JST	SPT			
1 (S)	1	0	1	1	0	1	0	0	1	0	1	1	0	1
2 (I)	0	0	0	0	0	0	0	0	1	0	0	0	0	1
3 (S)	0	0	0	1	0	0	1	0	0	0	1	0	0	1
4 (S)	1	0	0	0	0	0	1	0	1	0	1	0	1	1
5 (I)	1	1	0	1	0	1	1	1	1	1	1	1	1	1
6 (I)	0	0	0	1	1	0	0	0	1	1	1	0	0	0
7 (S)	1	0	0	0	0	0	1	0	1	0	1	0	1	0
8 (I)	1	0	1	0	0	1	0	0	1	0	1	0	0	0
9 (I)	1	1	0	1	0	0	1	0	1	0	1	0	0	1
10 (S)	1	0	0	1	0	0	1	0	1	0	1	1	0	1
11 (I)	0	0	0	0	0	0	1	0	1	0	1	1	0	1
12 (S)	0	0	0	1	0	0	0	0	0	0	0	0	0	1
13 (S)	1	0	1	1	0	0	0	0	1	0	1	0	0	1
14 (S)	0	0	1	0	0	1	1	0	0	0	1	0	0	1
15 (I)	1	1	0	0	1	1	0	0	0	0	1	0	0	1
16 (S)	0	0	0	0	0	0	0	0	0	0	1	0	0	1
17 (I)	1	0	0	0	0	0	0	0	0	0	0	0	0	0
18 (S)	1	0	0	1	0	0	0	0	1	0	1	0	0	1
19 (S)	0	1	0	0	0	0	0	0	0	0	1	0	0	1
20 (I)	1	0	1	1	0	1	1	1	0	0	1	1	0	1
21 (I)	0	1	0	0	0	0	0	0	0	0	1	0	1	1

ACCURACY (cont.)

OSCILLATOR

SCOPE

SUBJECT	OSCILLATOR						SCOPE					
	1	2	3	1	2	3	1	2	3	1	2	3
22 (S)	0	0	0	1	0	0	0	0	1	0	0	1
23 (S)	0	0	0	1	0	1	0	0	1	1	1	1
24 (I)	0	0	0	1	0	1	1	0	1	0	0	1
25 (I)	0	1	0	0	0	0	1	0	0	0	0	1
26 (I)	0	0	1	0	0	1	0	0	1	1	0	1
27 (I)	1	0	0	0	1	1	1	0	1	1	0	1
28 (I)	0	0	0	1	0	0	1	0	0	0	0	0
29 (S)	0	0	0	0	0	0	1	0	0	0	0	1
30 (S)	1	1	1	0	0	1	0	0	0	0	0	0
31 (I)	1	1	0	1	1	0	1	0	1	1	0	1

APPENDIX C
TIME TO COMPLETION RAW DATA

TIME TO SOLUTION OSCILLATOR SCOPE

SUBJECT	JST			SPT			JST			SPT		
	1	2	3	1	2	3	1	2	3	1	2	3
1 (S)	21.25	33.33	44.25	26.17	24.00	24.33	57.58	60.00*	28.42	26.00	56.75	17.25
2 (I)	16.42	21.00	30.25	13.75	24.50	11.00	49.92	27.67	9.50	29.50	41.75	14.25
3 (S)	58.50	11.92	17.42	18.17	24.75	15.67	26.50	45.50	30.00	46.92	33.75	29.75
4 (S)	9.67	13.00	15.17	26.17	16.67	43.50	38.75	25.42	12.00	25.42	40.50	15.42
5 (I)	31.75	27.50	21.25	40.50	59.50	34.50	40.50	21.00	14.50	50.17	45.33	20.50
6 (I)	8.50	20.00	12.08	26.25	33.58	17.25	57.00	33.50	18.25	22.50	51.00	28.00
7 (S)	9.75	17.25	16.00	10.17	17.50	24.50	15.83	49.83	12.33	10.00	57.50	33.75
8 (I)	49.50	24.92	33.00	60.00	39.75	55.33	34.50	60.00	20.25	43.00	12.75	60.00*
9 (I)	26.00	20.00	36.67	60.00	25.67	30.00	40.50	60.00	26.50	50.00	60.00*	29.25
10 (S)	35.50	24.50	20.75	18.25	16.25	60.00*	49.08	37.00	23.75	43.17	23.50	10.25
11 (I)	28.50	30.17	55.50	60.00*	19.50	60.00	41.25	55.50	16.50	38.00	60.00*	18.50
12 (S)	36.17	30.17	49.50	38.75	30.50	25.00	60.00	40.00	32.00	36.58	60.00*	18.00
13 (S)	40.75	22.25	59.25	20.00	20.50	31.50	24.50	60.00*	15.33	20.25	60.00*	20.33
14 (S)	30.50	60.00*	35.83	40.25	33.25	39.83	25.17	43.50	45.58	20.25	36.25	14.83
15 (I)	15.17	5.50	23.50	8.58	5.17	26.17	25.17	60.00*	18.58	41.92	36.00	8.75
16 (S)	22.58	50.50	60.00*	60.00	43.50	35.75	60.00*	60.00*	46.17	33.50	60.00*	8.58
17 (I)	31.50	17.17	7.17	5.17	8.33	6.33	4.17	60.00*	32.25	10.17	47.25	2.17
18 (S)	27.25	59.75	43.50	49.50	34.50	32.50	43.50	41.00	53.50	60.00*	39.50	12.25
19 (S)	15.50	16.17	22.00	42.17	36.00	23.75	39.75	54.25	26.00	22.50	60.00*	18.00
20 (I)	11.75	12.00	41.50	8.17	47.17	15.25	32.33	42.25	14.25	23.00	48.00	9.33
21 (I)	14.00	40.17	54.17	15.08	40.17	35.33	50.17	60.00*	28.33	25.17	42.50	20.25

TIME TO SOLUTION (cont.) OSCILLATOR

SCOPE

SUBJECT	JST			SPT			JST			SPT		
	1	2	3	1	2	3	1	2	3	1	2	3
22 (S)	20.58	30.50	14.17	18.67	26.58	13.25	8.50	18.75	18.83	22.50	31.33	8.33
23 (S)	29.00	30.50	31.00	32.08	25.25	25.50	27.00	30.25	7.17	44.08	34.17	6.17
24 (I)	16.17	16.17	15.33	19.25	15.17	35.00	33.00	18.50	11.42	24.75	5.00	18.67
25 (I)	19.00	24.42	25.17	24.42	17.67	21.33	36.67	34.50	19.00	12.58	26.67	14.25
26 (I)	7.25	7.83	20.25	17.83	14.42	9.92	12.50	32.25	17.58	31.00	60.00*	33.67
27 (I)	10.50	11.42	29.58	46.75	5.50	35.83	15.42	48.17	12.25	20.00	20.17	22.75
28 (I)	10.00	6.25	6.00	14.25	11.00	14.00	12.67	21.50	9.67	11.50	60.00*	12.00
29 (S)	30.17	31.25	34.75	20.58	16.25	40.42	51.25	30.75	20.17	60.00	45.00	16.50
30 (S)	19.00	13.75	25.00	55.60	20.25	57.00	60.00*	42.17	5.33	27.42	12.25	35.75
31 (I)	30.50	34.17	18.33	9.00	10.58	18.33	15.92	56.23	23.25	12.50	45.25	8.00

APPENDIX D
STEPS TO COMPLETION RAW DATA

SUBJECT	STEPS TO SOLUTION					OSCILLATOR					SCOPE					
		JST			SPT		JST			SPT		JST			SPT	
1	2	3	1	2	3	1	2	3	1	2	3	2	3	1	2	3
1 (S)	4	6	3	3	3	4	5	3	1	5	3	5	3	1	5	3
2 (I)	4	11	2	4	4	4	6	4	4	4	4	6	4	3	6	1
3 (S)	3	3	6	7	3	6	4	8	4	7	8	4	4	4	4	8
4 (S)	4	6	5	6	5	7	8	4	4	6	8	4	4	5	7	3
5 (I)	8	6	5	8	7	9	8	6	6	8	6	8	6	5	6	5
6 (I)	3	7	7	5	2	7	8	4	4	5	4	8	4	2	5	5
7 (S)	5	6	2	5	3	5	9	3	5	5	3	9	3	-	14	9
8 (I)	9	4	21	6	9	4	11	2	4	6	2	11	2	3	3	5
9 (I)	10	11	11	5	3	12	17	8	12	5	8	17	8	2	3	4
10 (S)	7	6	2	4	7	10	12	9	10	4	9	12	9	6	3	1
11 (I)	7	9	14	6	5	6	8	4	6	6	4	8	4	2	10	5
12 (S)	Lost	Lost	6	4	5	2	4	3	2	4	3	4	3	3	5	5
13 (S)	7	3	4	3	6	4	11	4	4	3	4	11	4	3	7	2
14 (S)	3	?	4	6	9	5	10	5	5	6	5	10	5	4	5	2
15 (I)	5	3	2	2	6	5	9	4	5	2	4	9	4	7	7	2
16 (S)	2	5	3	2	3	10	4	7	10	2	4	4	7	1	-	1
17 (I)	3	4	2	3	1	-	5	6	-	3	6	5	6	3	6	1
18 (S)	4	12	9	8	11	6	9	5	6	8	9	9	5	3	12	4
19 (S)	3	5	7	8	4	4	8	3	4	4	8	8	3	4	8	5
20 (I)	5	9	2	11	4	6	11	6	4	11	11	11	6	4	8	2
21 (I)	3	4	1	3	1	8	8	2	8	3	8	8	2	1	3	2

STEPS TO SOLUTION (cont.) OSCILLATOR SCOPE

		JST			SPT			JST			SPT	
SUBJECT	1	2	3	1	2	3	1	2	3	1	2	3
22 (S)	3	4	3	2	5	2	1	3	3	-	5	1
23 (S)	6	6	7	13	5	5	7	8	1	4	7	2
24 (I)	10	11	7	7	6	8	9	4	4	6	1	7
25 (I)	3	9	4	4	3	3	3	8	5	2	3	3
26 (I)	3	5	11	10	4	2	4	9	7	5	7	2
27 (I)	4	4	6	5	2	5	5	7	3	1	2	1
28 (I)	2	3	2	2	3	4	3	5	3	2	6	2
29 (S)	8	6	7	4	3	6	8	10	6	5	5	4
30 (S)	7	3	10	7	5	7	-	8	1	5	4	5
31 (I)	5	7	6	2	2	2	4	3	6	1	8	1

STEPS TO SOLUTION

OSCILLATOR

SCOPE

			JST			SPT				JST		SPT	
SUBJECT	1	3	2	1	3	2	1	3	2	1	3	2	3
1 (S)	4	6	6	3	2	3	4	3	5	5	3	5	3
2 (I)	4	6	11	2	2	4	4	4	6	6	3	6	1
3 (S)	3	3	3	6	3	7	6	8	4	4	4	4	8
4 (S)	4	6	6	5	5	6	7	4	8	5	7	7	3
5 (I)	8	9	6	5	7	8	9	6	8	5	6	6	5
6 (I)	3	4	7	7	2	5	7	4	8	2	4	5	5
7 (S)	5	8	6	2	3	5	5	3	9	9	-	14	9
8 (I)	9	8	4	21	9	6	4	2	11	2	3	3	5
9 (I)	10	19	11	11	3	5	12	8	17	2	3	3	4
10 (S)	10	7	6	2	7	4	10	9	12	6	3	3	1
11 (I)	7	7	9	14	5	6	6	4	8	4	2	10	5
12 (S)	Lost	7	Lost	6	5	4	2	3	4	3	3	5	5
13 (S)	7	5	3	4	6	3	4	4	11	3	3	7	2
14 (S)	3	6	2	4	9	6	5	5	10	4	4	5	2
15 (I)	5	2	3	2	6	2	5	4	9	7	7	7	2
16 (S)	2	6	5	3	3	2	10	7	4	1	-	-	1
17 (I)	3	5	4	2	1	3	-	6	5	3	6	6	1
18 (S)	4	8	12	9	11	8	6	5	9	3	3	12	4
19 (S)	3	5	5	7	4	8	4	3	8	4	4	8	5
20 (I)	5	5	9	2	4	11	6	6	11	4	4	8	2
21 (I)	3	5	4	1	1	3	8	2	8	1	3	3	2