

AD-A063 586

INSTITUTE FOR DEFENSE ANALYSES ARLINGTON VA  
RECENT DEVELOPMENTS IN THE ESTIMATION OF POTENTIAL EFFECTS OF H--ETC(U)  
OCT 78 R C OLIVER, E BAUER, W WASYLKIWSKYJ DOT-FA77WA-3965  
P-1343 FAA-AEE-78-24 NL

UNCLASSIFIED

1 OF 3

AD A063586



**LEVEL**

**12**

Report No. FAA-AEE-78-24

**RECENT DEVELOPMENTS IN THE ESTIMATION OF POTENTIAL EFFECTS  
OF HIGH ALTITUDE AIRCRAFT EMISSIONS ON OZONE AND CLIMATE**

(Institute for Defense Analyses Paper P-1343)

**R. C. Oliver  
with  
E. Bauer  
W. Wasylkiwskyj**



October 1978

**INTERIM REPORT**

Prepared for

**HIGH ALTITUDE POLLUTION PROGRAM  
U.S. DEPARTMENT OF TRANSPORTATION**

**FEDERAL AVIATION ADMINISTRATION  
Office of Environment and Energy  
Washington, D.C. 20591**

**AD A063586**

**DDC FILE COPY.**

RECEIVED  
JAN 23 1979

This document has been approved  
for public release and sale; its  
distribution is unlimited.

79 01 22 085

**This document is disseminated under the sponsorship of the Department of Transportation in the interest of information exchange. The United States Government assumes no liability for its contents or use thereof.**

**The work reported in this document was conducted under Contract No. DOT-FA-77WA3965 for the Department of Transportation. The publication of this IDA Report does not indicate endorsement by the Department of Transportation, nor should the contents be construed as reflecting the official position of that agency.**

9 Interim rept.  
15 Apr 77-15 Oct 78

12 198p.

Technical Report Documentation Page

18 1. Report No. FAA-AEE-78-24	2. Government Accession No.	3. Recipient's Catalog No.	
6 4. Title and Subtitle Recent Developments in the Estimation of Potential Effects of High Altitude Aircraft Emissions on Ozone and Climate.		5. Report Date 11 Oct 1978	6. Performing Organization Code
10 R.C. Oliver, E. Bauer W. Wasyliwskyj		8. Performing Organization Report No. P-1343	10. Work Unit No. (TRAIS)
10 R.C. Oliver, E. Bauer W. Wasyliwskyj INSTITUTE FOR DEFENSE ANALYSES 400 Army-Navy Drive Arlington, VA 22202		11. Contract or Grant No. DOT-FA 77WA8965	
12. Sponsoring Agency Name and Address Department of Transportation Federal Aviation Administration Office of Environment and Energy Washington, D.C. 20591		13. Date of Report and Period Covered April 15, 1977 Interim October 15, 1978	
15. Supplementary Notes		14. Sponsoring Agency Code	
<p>16. Abstract</p> <p>A review is provided of recent (December 1976-June 1978) developments in problems associated with estimating the potential effects that aircraft emissions at cruise altitudes may have on the earth's protective ozone shield and/or surface climate. Background information is provided as deemed necessary for context. The review shows that one recently measured key reaction rate (<math>\text{HO}_2 + \text{NO} \rightarrow \text{NO}_2 + \text{HO}</math>) has had dramatic effects on the ozone question. Computed effects on the ozone column of nitrogen oxides (which, unless in very large quantity, now cause an increase) and water vapor emissions (which, unless thermal feedback effects are included, cause a decrease) from supersonic transports (at 17-20 km) are now small and, on balance, apparently positive, at least for moderate fleets (several hundred aircraft). Subsonic aircraft also appear to cause small increases in the ozone column; however, no new modeling results are available. The new <math>\text{HO}_2 + \text{NO}</math> rate has affected model duplication of the natural atmosphere adversely; another important new rate (<math>\text{HO}_2 + \text{O}_3 \rightarrow \text{HO} + 2 \text{O}_2</math>), not yet incorporated in available results, may reduce this difficulty. Second-order effects (thermal feedback) have become important, particularly in modeling water effects; the modeling of water transport processes, however, involves many uncertainties. Additional modeling studies are needed. Progress in emissions measurement uncertainties and brief comments on possibly important climatic aspects are also included.</p>			
17. Key Words ozone, climate, stratosphere, troposphere, aircraft emissions, supersonic aircraft, subsonic aircraft		18. Distribution Statement Document is available to the public through the National Technical Information Service, Springfield, Virginia 22151.	
19. Security Classif. (of this report) UNCLASSIFIED	20. Security Classif. (of this page) UNCLASSIFIED	21. No. of Pages 198	22. Price

179 350

Gu

ACCESSION for	
NTIS	Whole Section <input checked="" type="checkbox"/>
DDC	Half Section <input type="checkbox"/>
UNANNOUNCED	<input type="checkbox"/>
JUSTIFICATION	
BY	
DISTRIBUTION/ANAL. ADULT. COPIES	
Dist.	TOTAL
A	

## ABSTRACT

A review is provided of recent (December 1976-June 1978) developments in problems associated with estimating the potential effects that aircraft emissions at cruise altitudes may have on the earth's protective ozone shield and/or surface climate. Background information is provided as deemed necessary for context. The review shows that one recently measured key reaction rate ( $\text{HO}_2 + \text{NO} \rightarrow \text{NO}_2 + \text{HO}$ ) has had dramatic effects on the ozone question. Computed effects on the ozone column of nitrogen oxides (which, unless in very large quantity, now cause an increase) and water vapor emissions (which, unless thermal feedback effects are included, cause a decrease) from supersonic transports (at 17-20 km) are now small and, on balance, apparently positive, at least for moderate fleets (several hundred aircraft). Subsonic aircraft also appear to cause small increases in the ozone column, however, no new modeling results are available. The new  $\text{HO}_2 + \text{NO}$  rate has affected model duplication of the natural atmosphere adversely; another important new rate ( $\text{HO}_2 + \text{O}_3 \rightarrow \text{HO} + 2 \text{O}_2$ ), not yet incorporated in available results, may reduce this difficulty. Second-order effects (thermal feedback) have become important, particularly in modeling water effects; the modeling of water transport processes, however, involves many uncertainties. Additional modeling studies are needed. Progress in emissions measurement uncertainties and brief comments on possibly important climatic aspects are also included.

## ACKNOWLEDGMENTS

This document was prepared for the High Altitude Pollution Program of the Federal Aviation Administration under contract DOT-FA77WA-3965.

The authors are indebted to the numerous individuals cited herein who have contributed material, much of it in prepublication or draft form, for use in preparing this report. In addition, special thanks are due to those individuals who have provided valuable criticism and corrections on draft versions of this paper. These include: Mr. J. D. Few of ARO, Inc. at the Arnold Engineering Development Center, Mr. H. Hidalgo of the Institute for Defense Analyses, Dr. F. M. Luther and his coworkers of the Lawrence Livermore Laboratory, Dr. J. D. Mahlman of the Geophysical Fluid Dynamics Laboratory, and Dr. R. C. Whitten and coworkers at the Ames Research Center of the National Aeronautics and Space Administration. Any errors or misinterpretations in the material presented are, however, entirely the responsibility of the authors and in particular, of the principal author, who prepared this report in its entirety, with the exception of Appendix B.

## CONTENTS

ABSTRACT	iii
ACKNOWLEDGMENTS	v
SUMMARY	S-1
S.1 Background and Status in Brief	S-1
S.2 Aircraft Emissions	S-4
S.2.1 NO <sub>x</sub> Emissions Measurements	S-4
S.2.2 Fleet Projections	S-4
S.2.3 Fleet Emissions	S-4
S.2.4 NO <sub>x</sub> Emission Reduction	S-5
S.3 Ozone Modeling Developments	S-5
S.3.1 1-D Transport--General	S-5
S.3.2 1-D Transport of Water Vapor	S-6
S.3.3 Trace Species Measurements	S-6
S.3.4 Chemistry	S-7
S.3.5 SST Effects on Ozone	S-8
S.3.6 Subsonic Effects on Ozone	S-9
S.3.7 Model Validation	S-9
S.4 Climatic Effects	S-10
S.5 Recommendations	
S.5.1 Ozone Model Development	S-10
S.5.2 Fleet Effects	S-10
S.5.3 Ozone Model Validation	S-10
S.5.4 Chemistry	S-11
S.5.5 Transport and Feedback Effects	S-11
S.5.6 NO <sub>x</sub> Emission Index Uncertainties	S-11
S.5.7 Climate	S-12
1. INTRODUCTION AND BRIEF REVIEW	1-1
1.1 Fleet Projections and Altitude Distribution of Emissions	1-3
1.2 NO <sub>x</sub> Effects on the Ozone Column	1-3
1.3 Climatic Effects	1-5
2. AIRCRAFT EMISSIONS	2-1
2.1 NO <sub>x</sub> Measurement Uncertainties	2-1
2.1.1 Introduction	2-1
2.1.2 Background Data	2-1
2.1.3 Related Investigations	2-5
2.1.4 Significance: A Probably Upper-bound Estimate of NO <sub>x</sub> Emission Index of Concorde	2-14

2.2	Fleet Forecasts of Projections	2-16
2.3	Concorde Emissions Estimates	2-19
2.4	NO <sub>x</sub> Emission Reduction Efforts	2-25
2.5	Some Comments	2-34
3.	OZONE MODELING DEVELOPMENT	3-1
3.1	Introduction	3-1
3.2	Some Comments on PL95-95	3-1
3.3	Transport Processes: 1-D Parameterization	3-3
3.3.1	Background	3-3
3.3.2	N <sub>2</sub> O Tracer Studies and Derived K <sub>z</sub> Profiles	3-4
3.3.3	The NASA-Ames Model K <sub>z</sub> Profile	3-8
3.3.4	Latitude-Tropopause Adjustments	3-9
3.3.5	Some Relevant Aspects of a 3-D Tracer Study	3-9
3.3.6	Studies Using Zr-95 Data	3-11
3.3.7	The Water Problem	3-14
3.4	Some Important Measurements of Trace Species	3-21
3.5	Chemistry Changes and Modeling Results	3-23
3.5.1	Introduction	3-23
3.5.2	Chemistry Changes and Uncertainties	3-23
3.5.3	Other Modeling Changes	3-31
3.5.4	Effects of Recent Chemistry Changes on Model Atmospheres	3-32
3.5.5	Recent Calculations of Aircraft Effects (1-D)	3-34
3.5.6	2-D Model Results	3-57
3.6	Validation Attempts	3-57
4.	CLIMATIC EFFECTS	4-1
4.1	Introduction	4-1
4.2	The Various (and Changing) "Threats" to Ozone and Climate	4-2
4.3	Climate and Climate Modeling--Some Developments of Interest	4-6
4.3.1	Scope	4-6
4.3.2	Predictability of Climate Change	4-6
4.3.3	Stratospheric Aerosol Effects	4-8
4.4	A Soviet View	4-10
5.	REFERENCES	5-1
APPENDIX A	- An Alternative Look at the General Electric Emissions Data (Lyon et al., 1975; Lyon, 1975)	A-1
APPENDIX B	- On the Use of Zr-95 Data from Chinese Atmospheric Thermonuclear Explosions to Study Stratospheric Transport in a One- Dimensional Parameterization	B-1



## TABLES

2-1.	Average NO Concentration in the Exhaust of a YJ93-GE-3 Engine Comparison of Values Measured In-Situ by UV Absorption and Measured by Sampling	2-2
2-2.	J93 NO <sub>x</sub> Emission Indices	2-3
2-3.	Comparison of Optical and Probe Measurements for NO Using a T-56 Combustor	2-4
2-4.	Comparison of Emissions Measured with the Various Probes	2-10
2-5.	NO <sub>x</sub> Emission Index Data Comparisons	2-15
2-6.	Comparison of Concorde (Probe) and J93 NO <sub>x</sub> Results	2-16
2-7.	United States; Year 2000 Estimates	2-17
2-8.	Fleet Comparisons	2-18
2-9.	Concorde Route Network Summary	2-20
2-10.	Emission Indices for Concorde (g NO <sub>2</sub> /kg Fuel)	2-21
2-11.	Concorde Emission Indices (Other than NO <sub>x</sub> , SO <sub>2</sub> )	2-22
2-12.	Fuel Flow for a Nine-Concorde Fleet	2-23
2-13.	NO <sub>x</sub> Emissions (g NO <sub>2</sub> /Day) for a Nine-Concorde Fleet, Annual Average Temperatures	2-24
3-1.	Comparison of Results From Different Models for 18-km Injection	3-13
3-2.	Models and Runs Compared	3-35
3-3.	Aircraft and Fleet Characteristics	3-37
3-4.	Ozone Changes Calculated for 100 Aircraft with Different NO <sub>x</sub> Emission Indices	3-38
3-5.	Sensitivity Studies of Ozone Perturbations Due to SSTs	3-43
3-6.	Stratospheric Ozone Column Changes, Percent	3-45
3-7.	Ozone Column Changes Showing Effects of the Howard and Evenson (1977) Reaction Rate Measurement	3-49

79 01 22 085

3-8.	Effects of Combined $\text{NO}_x$ - $\text{H}_2\text{O}$ Injections on the Ozone Column Change/1976 $K_z$ Profile	3-56
4-1.	A Comparison of Anthropogenic Emissions as Threats to Ozone and Climate	4-3
A-1.	Apparent $\text{NO}_x$ Emission Indices vs. Downstream Positions J85-5, Military Power, Preliminary Test Results	A-4
A-2.	Summary of Emissions Data From Final J85-5 Tests	A-9
A-3.	Summary of Emissions Data From Final J79-15 Tests	A-10
B-1.	$x_0$ and $U(x_0)$ From Eq. (B.9) as Functions of Time (From Model I)	B-14
B-2.	Stratospheric Burden $B_T(t)$ For the Two-Step Model As a Function of Time, For Various Values of $d = K_{\text{stratosphere}}/K_{\text{troposphere}}$	B-16
B-3.	Time Correction $t_0$ as a Function of $K$	B-17
B-4.	Experimental Parameters for Various Tests Used in the Data Analysis	B-22
B-5.	Effective $K$ -Values Computed From Experimental Data	B-25
B-6.	Comparison of Results From Different Models for 18-km Injection	B-28

## FIGURES

2-1.	NO concentration as a function of the fuel-to-air ratio for turbine engine combustor exhaust obtained by various means.	2-6
2-2.	Sampling portions of the baseline, quick-quench and dilution probes.	2-9
2-3.	NO concentrations and static temperature profiles.	2-12
2-4.	NO <sub>x</sub> emission outlooks according to Diehl et al., 1977.	2-27
2-5.	NO <sub>x</sub> and CO emission indices under lean conditions.	2-29
2-6.	Theoretical and experimental pressure effects in NO <sub>x</sub> formation at various equivalence ratios as a function of pressure.	2-30
2-7.	NO <sub>x</sub> emission index at various equivalence ratios and inlet temperatures, showing stable flame, blowout, and operating margins.	2-31
2-8.	Auto ignition regions and droplet evaporating times as a function of combustor exit pressure and droplet diameter.	2-32
2-9.	The jet-induced combustor (JIC) and vortex air blast (VAB) combustor concepts.	2-33
2-10.	CO emissions with a vortex air blast (VAB) combustor simulated idle pressure with various inlet temperatures, illustrating rapid rise in CO at low inlet temperatures.	2-35
3-1.	Some eddy diffusivity profiles of interest	3-7
3-2.	Tracer study results.	3-10
3-3.	Water vapor mixing ratios.	3-18
3-4.	Globally averaged one-dimensional K <sub>z</sub> profile based on water, ozone and NO <sub>2</sub> fluxes and gradients; derived from 3-D results.	3-20
3-5.	Widhopf model results showing how use of the Howard-Evenson reaction rate distorts the model ozone profile relative to the measured atmosphere values.	3-33

3-6.	NASA-Ames 1-D model results plotted here to show effects of varying NO <sub>x</sub> injection rates at constant H <sub>2</sub> O injection rates.	3-39
3-7.	Separate effects of water and NO <sub>x</sub> injections at 20 km at various rates on the ozone column above 10 km as calculated at NASA-Ames (Poppoff et al., 1978) for three K <sub>z</sub> profiles.	3-40
3-8.	Effects of NO <sub>x</sub> and NO <sub>x</sub> and H <sub>2</sub> O injections at various altitudes on the ozone column above 10 km as calculated by NASA-Ames (Poppoff et al., 1978).	3-41
3-9.	Changes in calculated ozone depletions over the 1974-1976 period due to various changes in modeling parameters.	3-48
3-10.	Ozone column changes for 17 and 20 km NO <sub>x</sub> injections calculated at Lawrence Livermore Laboratory, using their 1-D model, for two eddy diffusivity profiles (Chang, 1976 and Hunter, 1974) with 1976 and 1977 chemistry sets.	3-51
3-11.	Percentage changes in ozone vs. altitude for three injection rates of NO <sub>x</sub> at 20 km.	3-53
3-12.	Lawrence Livermore Laboratory modeling results showing water effects on the ozone column with and without consideration of thermal feedback effects.	3-55
A-1.	Emissions concentrations vs. CO <sub>2</sub> for J85-5 engine, 30 feet aft of exhaust nozzle, military power.	A-5
A-2.	Emissions concentrations vs. CO <sub>2</sub> for J85-5 engine, 30 feet aft of exhaust nozzle, at max. A/B power.	A-6
A-3.	Emissions concentrations vs. CO <sub>2</sub> for J79-15 engine, 60 feet aft of exhaust nozzle, at military power levels.	A-7
A-4.	Emissions concentrations vs. CO <sub>2</sub> for J79-15 engine, 60 feet aft of exhaust nozzle, at max. A/B power.	A-8
A-5.	Apparent NO <sub>x</sub> emission index as a function of dilution, J85-5 military power.	A-13
A-6.	Apparent NO <sub>x</sub> emission index as a function of dilution, J79-15 military power.	A-14
A-7.	Apparent NO <sub>x</sub> emission index as a function of dilution J85-5, maximum afterburning.	A-15
A-8.	Apparent NO <sub>x</sub> emission index as a function of dilution, J79-15, maximum afterburning.	A-16

B-1.	Stratospheric Zr-95 burden (decay-corrected) following the Chinese nuclear tests.	B-6
B-2.	Observed vertical Zr-95 activity distribution for five high yield Chinese nuclear tests.	B-7
B-3.	Effective injection height for aerosols as a function of time, $\tilde{Z}(t)$ .	B-19
B-4.	Decay of stratospheric tracer burden as a function of time.	B-21
B-5.	Time for stratospheric tracer burden to decrease to 60 percent of its peak value, $t_{0.6}$ , computed with and without sedimentation, shown as a function of eddy diffusivity $K$ .	B-23
B-6.	The present results for an 11 km tropopause compared with some other, currently used, eddy diffusivity profiles.	B-29

## SUMMARY

This report summarizes recent (December 1976-June 1978\*) developments in the estimation of potential effects of aircraft emissions at cruise altitude on the protective ozone layer and on surface climate. Background information is provided as deemed necessary for context. The subjects covered include developments in aircraft emissions, ozone modeling (atmospheric dynamics and chemistry), and briefly, climate.

### S.1 BACKGROUND AND STATUS IN BRIEF

The subjects discussed herein have been under continuing study since about 1970 when the advisability of continuing development on the United States supersonic transport (SST) was being intensively debated. The original environmental argument related to exhaust water vapor reduction of the stratospheric ozone layer; in 1971 a much larger effect on ozone was predicated due to the nitrogen oxides ( $\text{NO}_x$ ) in the exhaust. Climatic effects due to water vapor and sulfur dioxide (from sulfur in the fuel) were also forecast. Although the U.S. SST was cancelled, the issues remained; also, other SSTs were in development. Accordingly, to pursue the questions raised, a large, several-year, multimillion-dollar study, the Climatic Impact Assessment Program (CIAP) of the Department of Transportation, was undertaken in late 1971. Results of this study (Grobeck et al., 1974), as well as of a concurrent National Academy of

---

\* The principal cutoff date for this work is June 1, 1978. Where feasible and critical however, certain information reported at the World Meteorological Organization (WMO) meeting (Toronto, June 26-30, 1978) has been included.

Sciences study (NAS, 1975), were released in 1974-75, largely confirming early predictions (but narrowing the range) of stratospheric ozone depletion due to  $\text{NO}_x$ , with water effects on ozone ambiguous, and also predicting climate changes (overall cooling) due to sulfur dioxide and water emissions; potential adverse effects were detailed at length. Furthermore, while the market situation for SSTs declined during CIAP, a worrisome extension of the stratospheric ozone depletion problem to include subsonic aircraft was added. Many unanswered questions remained.

In 1975, to implement and extend the findings of CIAP, the High Altitude Pollution Program of the Federal Aviation Administration was established. At about the same time, the newly recognized threat to the ozone layer from halocarbons came under intensive investigation by other groups. During the course of these various efforts, new chemical reaction rate constant measurements have been undertaken and new chemistry has been included, all of which have caused dramatic revisions in computed effects of aircraft emissions on the ozone layer. A comprehensive review of these various developments was prepared as of December 1976 and distributed in 1977 (Oliver et al., 1977). The 1977 review showed computed SST depletion effects on ozone (at constant  $\text{NO}_x$  input) to have declined substantially (although uncertainties increased), and that  $\text{NO}_x$  from subsonics would result in an increase in the ozone column, rather than the decrease reported in CIAP.

Changes since December 1976 have continued the above post-CIAP trends in  $\text{NO}_x$  effects on ozone, but have introduced certain new difficulties, in that modeling results reported herein are from models which do not adequately match the "natural" atmosphere. Matching of the natural atmosphere is generally considered to be a necessary (but clearly not a sufficient) condition to credibly predict effects of perturbations. However, very late chemistry changes, which have not yet been included,

should ameliorate this problem. Available modeling results are thus somewhat unsatisfactory; nevertheless, modeling efforts with rate constants treated parametrically permit certain observations as follows: *Currently (see S.3 below and Section 3.5.5 in the main text), it appears that the NO<sub>x</sub> constituent of engine exhaust from both SSTs at 17-20 km (except in very large numbers) and from subsonics at 9-14 km, will contribute to an increase in the ozone column; water vapor emissions, on the other hand, at least from SSTs, (will) tend to decrease ozone unless, as some modeling results indicate, radiative feedback effects compensate. The net effect on the ozone column, of combined water and NO<sub>x</sub> emissions, with current NO<sub>x</sub> emission indices, is apparently slightly positive for both classes of aircraft in foreseeable numbers.*

Quantitative estimates for the effects of projected fleets, combining revised forecasts with revised chemistry, are not yet available. It seems quite probable, however, that the effects over the next 20 years or so from subsonics will be greater than from supersonics. Subsonic aircraft tend to increase the ozone column by increasing the ozone concentration in the upper troposphere. Conceivably, this potential increase may become a matter of concern.

As discussed in our previous report (Oliver et al., 1977), climatic effects of both subsonics and supersonics are doubtful, but may involve warming; water vapor is probably the emitted ingredient of greatest climatic importance for either type of aircraft. More study is needed on effects of altered vertical profiles of radiatively significant species such as ozone and water vapor.

As in the past, many uncertainties remain. Recent developments are described in the following sections, with emphasis on matters which are felt to be of current interest.



## S.2 AIRCRAFT EMISSIONS

### S.2.1 NO<sub>x</sub> Emissions Measurements

Large uncertainties--factors of 2 to 6--still exist in aircraft NO<sub>x</sub> emission estimates, because spectroscopic techniques have yielded far higher values for NO than have standard probe techniques. Progress toward reducing these uncertainties is being made. Data have been accumulated which show that under some conditions, NO<sub>x</sub> in a hot gas stream can be destroyed on sampling, and that measured NO<sub>x</sub> contents vary with probe details. No probe design, however, has yielded NO results in hot gas streams as high as those found using ultraviolet spectroscopic techniques at the Arnold Engineering Development Center (AEDC). The spectroscopic techniques are difficult and are currently being investigated in detail. Final resolution of the differing results obtained by probe and spectroscopic techniques may well show that both techniques have been in significant error under some circumstances. A better understanding of proper measurement techniques should result.

### S.2.2 Fleet Projections

A recently published (February 1977) FAA document, *Aviation Futures to the Year 2000*, which is limited "almost exclusively to the United States," shows minimal expectation of SST traffic increase. Of five scenarios considered, only one, "Expansive Growth," includes any SST traffic; this implicitly unlikely scenario includes some 230 SSTs by the year 2000, with about 100 by 1990. An aircraft manufacturer's projection (McDonnell-Douglas) includes 118 SSTs by 1990. Continued growth in the subsonic fleet is generally expected.

### S.2.3 Fleet Emissions

A detailed global emissions estimate provided by British Aircraft Corporation is included for a small Concorde fleet (nine aircraft). Ozone change calculations for this fleet using

current chemistry have not been attempted, but would be exceedingly small.

#### S.2.4 NO<sub>x</sub> Emission Reduction

Some progress in achieving lower NO<sub>x</sub> emission indices in advanced combustors has been reported, but the problems in achieving substantial reductions in practical systems are evident. A significant aspect is that technological advances leading to improved performance (lower specific fuel consumption) appear to be in conflict with those leading to lower emissions; if conventional or modestly modified combustor technology is used, i.e., without emissions reduction techniques, a substantial increase in NO<sub>x</sub> emission index with time could be expected.

### S.3 OZONE MODELING DEVELOPMENTS

#### S.3.1 1-D Transport--General

N<sub>2</sub>O concentration vs. altitude measurements at various seasons and latitudes by Schmeltekopf et al. (1977) have resulted in new estimates of average vertical transport as used in 1-D models. Results show average vertical transport in the middle stratosphere (17-27 km) to be approximately twice as rapid as derived earlier by some modelers from CH<sub>4</sub> measurements. The powerful effect of including one tropical profile is evident. The N<sub>2</sub>O data, however, provide no information for the region near the tropopause critical to computation of aircraft effects. This region involves widely differing estimates by various modelers. A 1-D analysis, (Appendix B), of the transport of Zr-95 from a source at 40°N across the tropopause indicates stratosphere-to-troposphere transport rates to vary seasonally but, on the average, to be more rapid than implied by some K<sub>z</sub> profiles (e.g., Hunten, 1975; Turco and Whitten, 1977) and slightly slower than in others (e.g., Chang/1976); it is recognized, however, that the analysis is preliminary in view of certain simplifications introduced. A brief examination of

available 3-D modeling results from NOAA-GFDL\* indicates (qualitatively, because the computations are not fully reduced) support for 1-D models (such as Chang/1976) which show rather gradual transition across the "globally-averaged" tropopause; the 3-D modeling work also has shown earlier that feedback (troposphere-to-stratosphere) of excess C-14 is significant after one year or so, suggesting that this tracer is applicable primarily at relatively early times following injection. It can, of course, be debated whether tropospheric-stratospheric transport can be adequately represented in such models for sources near the tropopause.

### S.3.2 1-D Transport of Water Vapor

Injections of water vapor into the stratosphere by aircraft have become of increasing interest in terms of effects on ozone and climate, as noted above. Appropriate procedures for modeling this tracer are, however, in some doubt: sources and sinks are not well established. The tropical tropopause cold trap concept does not operate satisfactorily in 1- or 2-D models. More study on this problem is needed, particularly if thermal (radiative) feedback effects, which are evidently important, or both chemistry effects and water content itself (through changes in the tropical tropopause temperature) are to be estimated. Only 3-D modeling, perhaps using models more advanced than those presently available, would seem to be adequate for the feedback estimates; as a practical necessity however, techniques to decouple this aspect from the detailed chemical calculations must be considered.

### S.3.3 Trace Species Measurements

Of the many trace species measurement programs, two merit particular mention because of the questions raised by the results

---

\* National Oceanic and Atmospheric Administration-Geophysical Fluid Dynamics Laboratory

obtained. The first of these is the various Cl and ClO measurements of Anderson et al. (1977); one set of these, in particular, shows an inexplicably large stratospheric ClO content ( $\sim 8$  ppb). Chlorine content and chlorine chemistry, both of which (along with the measurements themselves) are placed in question by these measurements, affect the response of stratospheric ozone to  $\text{NO}_x$  injections. The second relates to the  $\text{NO}_2$  measurements by Noxon (1978), who finds  $\text{NO}_2$  contents in the troposphere to be an order-of-magnitude smaller than previously believed.  $\text{NO}_2$  content in the troposphere affects tropospheric chemistry (OH,  $\text{O}_3$  contents) and thereby the response of tropospheric (and, in fact, stratospheric) ozone to  $\text{NO}_x$  and numerous other injectants.

#### S.3.4 Chemistry

The single most significant recent development in ozone chemistry and its modeling has been the direct measurement of the rate of the reaction of  $\text{HO}_2$  with NO (Howard and Evenson, 1977), indicating a 40-fold increase in rate at room temperature over a previous (CIAP-era) evaluation. The temperature coefficient has been reported to be moderately positive, the rate increasing slightly with decreased temperature (Howard, 1978). Use of this rapid rate leads to substantially increased ozone content in model "natural" atmospheres, an increase which is particularly evident in 2-D models and is of sufficient magnitude to be of concern. However, direct measurement of the  $\text{HO}_2 + \text{O}_3$  reaction rate has also been reported very recently (Zahniser and Howard, 1978); the new rate should ameliorate the excess ozone problem, but evaluation runs are not yet available.  $\text{HO}_2$  chemistry is apparently becoming moderately well established, although important uncertainties still exist (as, e.g., in the  $\text{HO}_2 + \text{OH}$  and methane oxidation reactions) and possible pressure dependencies, temperature effects, etc., still need investigation.

A number of species have been noted as being of new or altered significance; among these are  $\text{HO}_2\text{NO}_2$ ,  $\text{H}_2\text{O}_2$ , and  $\text{HOCl}$ . Certain reactions and trace species contents in the troposphere are also of indirect but potentially great significance to stratospheric ozone; reactions affecting troposphere OH content affect the lifetime of methane and hydrogen-containing chlorocarbons, and thus the flux of such materials into the stratosphere.

### S.3.5 SST Effects on Ozone

Three recent 1-D studies are reviewed: as indicated above, none of these specifically include the latest  $\text{HO}_2 + \text{O}_3$  reaction rate, but available parametric evaluations indicate clearly that the new rate will increase the probability that  $\text{NO}_x$  injections at SST altitudes will lead to an increase in the ozone column. In general, as computed, the three studies reviewed agree that recent chemistry changes (primarily the  $\text{HO}_2 + \text{NO}$  change) lead to local enhancement of ozone from  $\text{NO}_x$  injected at SST altitudes (17-20 km). The net column effect for "Moderate" injections (of the order of, say, the expansive growth 230 SST, year 2000, fleet noted above, is probably positive as indicated, but depends nevertheless on the exact choice of reaction rates, emission indices ( $\text{NO}_x/\text{H}_2\text{O}$  ratio), and a number of modeling details ( $K_z$  profile, feedback effects). For "very large" injections, however (the magnitude depending on the  $K_z$  profile used), column ozone depletion is expected due to "saturation" of the ozone-enhancement effect in mid-altitudes and an increase in destruction at higher altitudes. Water vapor additions cause slight ozone decreases in the two models where its effects have been studied under fixed temperature assumptions; if thermal feedback (stratospheric cooling effects of the added water) effects are included, the effect of water additions on the ozone column become either negligible or enhancing. As indicated above, higher order modeling of such feedback effects is desirable, as, obviously, would be better knowledge of thermal and

possibly pressure effects on rate coefficients. The water/ $\text{NO}_x$  ratio is clearly a variable of interest; there may be, depending on further evaluation of feedback effects, an optimum cruise value leading to minimum risk to the ozone column, probably varying with fleet size and altitude.

#### S.3.6 Subsonic Effects on Ozone

No new results are available for the effects of subsonics on the ozone column. The new rate for  $\text{HO}_2 + \text{NO}$ , however, can be expected to increase ozone enhancements for specified  $\text{NO}_x$  injections.

#### S.3.7 Model Validation

As noted above, use of "current" chemistry (i.e., without the late  $\text{HO}_2 + \text{O}_3$  rate result) to model the "natural" atmosphere involves some new questions, as there is a tendency for the models to generate too much ozone; the problem is most evident with 2-D models. The newly reported  $\text{HO}_2 + \text{O}_3$  rate will alleviate this problem, but by how much is not yet established. For the perturbed atmosphere, some partial success in matching short-term, observed ozone depletions to model predictions has been achieved in both 1-D and 2-D models for solar proton events, but unexplained aspects exist. Moreover, significant apparent anomalies still exist over the longer term in comparing ozone destruction predictions to ozone records in the cases of nuclear weapons tests and chlorofluorocarbon releases. A dominant factor appears to be variation in solar ultraviolet output with time. The various modeling efforts all need to be reexamined in the light of up-to-date chemistry. Studies with 2-D or 3-D models, recognizing the array of known ongoing perturbing influences, will be of particular interest to the questions involved. A time-dependent 2-D "catalog" of perturbing influences over the period 1955-1975 has been prepared (Bauer, 1978).

## S.4 CLIMATIC EFFECTS

Little new information has been developed specific to the climatic effects of aircraft effluents. Climatic research, of course, continues and all such work has some relevance. A brief review is included of current problem areas and probable climatic effects. It is noted that the probable climatic effect of most long-lived anthropogenic pollutants ( $\text{CO}_2$ ,  $\text{N}_2\text{O}$ , halocarbons) of current concern is to cause warming; these effects will add to any effects (also probably, a small warming) due to aircraft effluents.

## S.5 RECOMMENDATIONS

### S.5.1 Ozone Model Development

Existing models need examination to determine the cause of, and to remove, a tendency for such models to yield too much ozone in the natural atmosphere; the new  $\text{HO}_2 + \text{O}_3$  rate constant (Zahniser and Howard, 1978) should help.

### S.5.2 Fleet Effects

New modeling runs are needed to develop estimates vs. time of the effects on the ozone column of future (particularly subsonic) fleets. These calculations should be time-dependent and should include expected time-dependent variations in the atmospheric halocarbon concentrations. Consideration should be given to whether (and when) the expected ozone column effects due to subsonic aircraft may become a matter of concern.

These runs should be in both 1-D and 2-D, and should be carried out only when (and if) modeling peculiarities introduced by recent changes in chemistry are clarified.

### S.5.3 Ozone Model Validation

The most important factor causing changes in the ozone column in recent decades appears to be solar ultraviolet

variability, but the variations are poorly established quantitatively. It is essential for model validation to obtain data on solar ultraviolet variability with time if long-term anthropogenic influences are to be verified.

#### S.5.4. Chemistry

Continued study of HO<sub>2</sub> chemistry is called for to remove doubts about pressure effects and competing mechanisms; in some cases (HO<sub>2</sub> + OH, e.g.), additional rate and temperature sensitivity data are needed. Some species (HOCl, HO<sub>2</sub>NO<sub>2</sub>, H<sub>2</sub>O<sub>2</sub>, HCHO), and their formation and breakdown paths and products need more investigation. Some reactions, considered unimportant in initial screening (such as OH + OCl) merit examination in view of an evident (if perhaps unlikely) potential significance. Methane oxidation chemistry also needs increased attention.

#### S.5.5 Transport and Feedback Effects

Wide discrepancies still exist among the various 1-D models on the rate of transport across the tropopause. These discrepancies need resolution through examination of the behavior of various tracers, particularly from those deposited in the stratosphere at known altitudes and latitudes, from studies of potential vorticity, and from three-dimensional modeling efforts. Water vapor transport is of particular interest; studies of HTO from nuclear weapons tests may be of value. Thermal feedback effects, as on stratospheric and tropical tropopause temperatures, need investigation, almost certainly requiring use of (possibly improved) 3-D models. Following phenomenological studies, parameterized feedback procedures in lower dimensionality models may be feasible for studies of the ozone chemistry involved.

#### S.5.6 NO<sub>x</sub> Emission Index Uncertainties

Possible errors in probe techniques have been clarified in recent work. Errors may also exist in the spectroscopic techniques. Work underway should be continued.



### S.5.7 Climate

Thermal feedback effects have been shown to be significant in 1-D modeling. To better quantify these complex effects, however, and particularly to estimate changes in stratospheric water content resulting from changes in tropical tropopause temperature, additional, preferably 3-D, modeling studies are needed. Studies in 1-D models of the coupled climatic-chemical effects of simultaneous injections of  $\text{NO}_x$ ,  $\text{H}_2\text{O}$ ,  $\text{SO}_2$ , etc. (i.e., aircraft engine effluents), with resultant changes in the altitude distribution of ozone, and other trace species would, however, be of interest.

## 1. INTRODUCTION AND BRIEF REVIEW

This report presents continuing developments in the problem of predicting effects that future fleets of high-flying aircraft may have on the ozone column and on surface climate. The issues arose in the 1970-71 time frame during debates on the advisability of continuing the United States supersonic transport (SST) program. Initial concern was with water effluents, with a postulated decrease in ozone resulting and with some possible impact on climate. The concerns shifted later (1971) as rate constants were reevaluated, to emphasize  $\text{NO}_x$  which, in a catalytic ozone destruction cycle (Crutzen, 1970; Johnston, 1971), was postulated to lead to substantial ozone destruction [3 to 50 percent, Johnston (1971), depending on assumptions], should large fleets of SSTs come into operation (Crutzen, 1971, 1972; Johnston, 1971). Concern with the climatic effects of  $\text{SO}_2$  arising from sulfur in the fuel and the sulfuric acid derived therefrom were also expressed in this time frame.

Although the United States SST program was canceled, the issues and the scientific problems remained, as other SSTs were in development elsewhere and the possibility remained that new SSTs might be developed in the future. To pursue these matters, a large multimillion dollar, multidisciplinary program, the Climatic Impact Assessment Program (CIAP), was sponsored by the Department of Transportation, beginning in 1971; the Report of Findings from this program was released in early 1975 (Grobecker et al., 1974). This study, as well as concurrent studies by the National Academy of Sciences (NAS, 1975) and by the United Kingdom (COMESA, 1975), largely affirmed that  $\text{NO}_x$  emissions from

aircraft would have a deleterious effect on the ozone column, although the estimated magnitudes of the effect differed. Comparison to pre-CIAP estimates was difficult due to the wide ranges ranges quoted, the differing averages involved (global, hemispheric, or corridor), differing estimates concerning the average flight hours per day per SST and thus  $\text{NO}_x$  emissions to be expected per year, etc. A nominal Northern Hemisphere figure for 500 large advanced mach 2.7 SSTs operating at 19.5 km (not 500 of the canceled U.S. SSTs) according to the CIAP Report of Findings would be 9 percent depletion in the Northern Hemisphere; the NAS procedures, which used greater fuel flow estimates, gave about 15 percent. Effects per unit of (continuous)  $\text{NO}_x$  emission were noted to decrease with decreasing altitude; however, even subsonics, and particularly advanced subsonics operating to nearly 14 km, were implied to represent a significant threat to the ozone column in view of expected growth rates. Water emissions were considered to have little effect on ozone. The CIAP report gave considerable discussion to the cooling climatic effect of  $\text{SO}_2$ , which was reportedly larger (at 0.05 percent sulfur in the fuel), than the warming effect of water vapor and the small effects of other exhaust ingredients. Climatic effects were still implied to be rather small, and of more remote concern in a time sense, than were the ozone effects.

In 1975, in order to implement the findings of and to extend the investigations carried out in CIAP, the High Altitude Pollution Program (HAPP) of the Federal Aviation Administration was begun. About this time also, the effects of halocarbons (chlorofluoromethanes and others) on the ozone layer became a matter of considerable national scientific interest, and much research was undertaken. This research made evident the greater complexity of stratospheric chemistry than had been recognized in CIAP; of more importance to the aircraft problem, however, certain reaction rates, previously evaluated somewhat indirectly, were begun to be measured directly.

All of these matters were reviewed in a previous report, prepared under FAA/ HAPP sponsorship (Oliver et al., 1977), based on information available as of December 1976. The report emphasized developments in the 1975-76 time period and noted changes which had occurred relative to findings and assumptions reported in CIAP (Grobeck et al., 1974) and in NAS, 1975. A brief review of that work, conducted in the 1975-76 period and of the developments which resulted, follows.

### 1.1 FLEET PROJECTIONS AND ALTITUDE DISTRIBUTION OF EMISSIONS

Changes in fuel prices and general economic conditions between the initiation times of CIAP and of HAPP, and recognition of the need for better altitude resolution for emissions near the tropopause, made new projections necessary. These were made and resulted in substantially altered and more detailed projections. These projections did not include a large, mach 2.7 advanced SST by 1990, as had CIAP. In addition, future fuel consumption by SSTs, expected fleet growth rates, and fuel consumption by advanced subsonics at peak cruise altitudes (near 14 km) were all found to be much lower than in CIAP. However, a caveat persisted, in that  $\text{NO}_x$  emission estimates were in question because of a large measurement discrepancy between accepted probe-sampling techniques and a new in situ ultraviolet spectroscopic technique. The spectroscopic technique indicated much large values for  $\text{NO}_x$ .

### 1.2 $\text{NO}_x$ EFFECTS ON THE OZONE COLUMN

A review of the chemistry (reaction rates) controlling the production and destruction of ozone in an  $\text{NO}_x$ - $\text{HO}_x$ - $\text{O}_x$  atmosphere indicated that uncertainties were much larger than recognized in CIAP; it was shown that  $\text{NO}_x$  emissions from SSTs might actually increase the ozone column slightly rather than decrease it, or the effects could be substantially more deleterious than reported

in CIAP, all of these potential results being within reaction rate uncertainties. The uncertainties were largely in reactions involving the HO<sub>2</sub> radical. Uncertainties in parameterized transport also affected the results. Overall, for a specified NO<sub>x</sub> injection rate corresponding to a very large fleet (2000 molecule/cm<sup>3</sup>-sec over 1 km at 17 km, globally equivalent to about 4,000 Concorde), results varied from -17.0 percent to +2.2 percent global ozone change.

Water effects from aircraft exhaust were also studied briefly in these uncertainty studies. It was found that when NO<sub>x</sub> negative effects on ozone are maximized by a choice of reaction rates, water vapor, which is also present in the exhaust, increases ozone; where NO<sub>x</sub> effects on ozone are minimized or positive, the water emissions reduce ozone.

During the course of this and related work, recommended reaction rates were being changed and interactions of HO<sub>x</sub> and NO<sub>x</sub> with ClO<sub>x</sub> chemistry were being recognized. One particular reaction rate (for HO<sub>2</sub> + HO → H<sub>2</sub>O + O<sub>2</sub>) was revised downward (somewhat excessively by current estimates) ten-fold; this decreased computed SST effects on ozone some 40 percent, but increased effects of halocarbon injections. Interactions with ClO<sub>x</sub> cycles, which yield reduced (or positive) SST NO<sub>x</sub> effects on ozone with increased chlorine content, and other changes also combined to show reduced deleterious effects of SST NO<sub>x</sub> on ozone. In addition, ozone-forming reactions involving methane oxidation and nitrogen oxides, recognized but not included in CIAP, were put into some models. Inclusion of methane oxidation reactions in 2-D model studies showed that subsonics, in fact, appear to increase rather than decrease the ozone column; in addition, while supersonics tended, in these calculations, to decrease the ozone column, the combined effect of the projected 1990 "high" traffic fleet, including both supersonics and subsonics, was to increase ozone slightly. The increase varied with season and

latitude, with a maximum enhancement of about 1.4 percent. Uncertainties were recognized to be large in all these calculations.

### 1.3 CLIMATIC EFFECTS

Little new climate modeling work was undertaken in the HAPP program. However, as part of the review in Oliver et al., 1977, the postulated effects of the various exhaust ingredients were examined in detail, using available models, estimates of residence times, etc. The work was aimed at determining, to the degree possible, the effect of SST exhaust on climate, rather than focusing on the effects of  $\text{SO}_2$ , which results from a removable (at some cost) impurity in the fuel. These calculations indicated that, according to available models, the water effect (warming) is greater than the sulfur effect (at 0.05 percent sulfur), or other effects ( $\text{NO}_2$ , ozone changes); the net result appeared to be a warming due to SST aircraft exhaust, rather than a cooling. The same calculations were not applied to the subsonic fleet, it being argued that the models, which do not include contrail effects (which may be dominant) are inapplicable. Climatic effects for the SST portion of the 1990 "high" HAPP fleet were found to be small (0.00 to 0.02 K); however, for large fleets of advanced SSTs, climatic effects from water vapor might well limit fleet size, assuming some specified warming value (0.1 K, for example) from aircraft could not be exceeded.

It is evident from the above that many changes in the understanding of aircraft effects occurred in the period between December 1974 (the date of the CIAP Report of Findings; Grobecker et al., 1974) and December 1976, the cutoff date for the Oliver et al., 1977, report. The rate of change was such that further changes could be anticipated. These have indeed occurred, particularly in the ozone modeling area. Relatively little recent attention has been given to climatic effects of aircraft exhaust, and equivalently dramatic changes are lacking. This report summarizes these recent developments, as of June 1, 1978; where

feasible and critical however, certain information presented at the World Meteorological Organization in Toronto (June 26-30, 1978) has been included. No attempt to include other developments which may have been reported during June 1978 has been made. An attempt is made, however, to give enough additional background material so that coherence and perspective are maintained.

The material that follows is organized in the same general fashion as have been previous reports (Grobeck et al., 1974; Oliver et al., 1977); thus, aircraft emissions are first discussed, followed by a treatment of ozone effects and (minimally), climatic effects. Conclusions and recommendations from these efforts have been brought forward to the summary section, already presented.

## 2. AIRCRAFT EMISSIONS

### 2.1 NO<sub>x</sub> MEASUREMENT UNCERTAINTIES

#### 2.1.1 Introduction

As discussed in the earlier report (Oliver et al., 1977), optical measurements of NO in aircraft exhaust have disagreed sharply with measurements made according to standard probe techniques (SAE ARP 1256). The disagreements were first noticed in work begun at AEDC in 1972 (Davidson and Domal, 1973) and are not yet resolved, but some new information is available. A brief history of the problem, some reinterpretation of old data, and these recent developments follow.

#### 2.1.2 Background Data

Representative data obtained by Davidson and Domal (1973) are given in Table 2-1. The tests were made with a J93 engine mounted in an altitude test cell. The optical procedure (see McGregor et al., 1973) utilized the NO (0,0)  $\gamma$ -band, measuring absorption in individual spectral lines in the ultraviolet (225 to 227 nm). The probe procedure used standard techniques, with the gas samples being brought through an orifice and a sampling line to analytical apparatus.

Note that large disagreements occurred, particularly at higher mach numbers and altitudes and under afterburning conditions. No data were obtained at subsonic conditions.



TABLE 2-1. AVERAGE NO CONCENTRATION IN THE EXHAUST OF A YJ93-GE-3 ENGINE  
 COMPARISON OF VALUES MEASURED IN-SITU BY UV ABSORPTION AND  
 MEASURED BY SAMPLING. (DAVIDSON AND DOMAL, 1973)

<u>Simulated Flight Conditions</u>			<u>Concentration Measurements, ppm</u>	
<u>Mach</u>	<u>Altitude, thousands of ft</u>	<u>Power Setting</u>	<u>Absorption</u>	<u>Sampling</u>
1.4	35	Military	75	56
2.0	55	Military	165	70
		Minimum Afterburning	175	80
		Maximum Afterburning	278	110
2.6	66	Military	323	100
		Maximum Afterburning	617	130

It is of interest that analytical data obtained on sample gases which had passed through a probe and sample line were in reasonable agreement using several techniques, including chemiluminescence, dispersive infrared, and wet chemistry techniques (and, as will be shown shortly, by UV spectrometry). Dispersive infrared data (on the probe-sampled gases) were reported by Forney (1973) and were within 10 or 15 percent of the chemiluminescence techniques under all conditions. Comparison of the wet chemistry data to that based on the chemiluminescence data were not made by Davidson and Domal, but are reported in Table 2.2 using their data.

These large disagreements prompted further work. In one study, at Wright-Patterson AFB, a T-56 jet engine combustor was used, and two different optical in-situ techniques (IR and UV) were used along with conventional sampling procedures. Two groups of investigators were involved, one group from AEDC (Few et al., 1976) and one from Aeronutronic (Gryvnak and Burch, 1976). The inlet air temperature to the combustor was 756 K (900°F), pressure was 120 psig,\* and a fuel-to-air ratio of 0.013 was used.

\*M. Roquemore, Wright-Patterson AFB, private communication, 12 April 1977.

TABLE 2-2. J93 NO<sub>x</sub> EMISSION INDICES. PROBE DATA.  
WET CHEMISTRY vs. CHEMILUMINESCENCE

Data source: Davidson and Domal, FAA-RD-73-66 (1973)

From Table VI, p. 64 (in order)

Approximate O<sub>2</sub> check\* (assume O<sub>2</sub> in H<sub>2</sub>O = 0.5 CO<sub>2</sub>)

O <sub>2</sub>	15.0	8.6	15.2	10.8	17.8	9.8
CO <sub>2</sub>	3.6	8.9	3.7	5.9	2.7	9.0
H <sub>2</sub> O	<u>1.8</u>	<u>4.45</u>	<u>1.85</u>	<u>2.95</u>	<u>1.35</u>	<u>4.5</u>
Total	20.4	21.95	20.75	19.65	21.85	23.3
Corrected O <sub>2</sub> **	20.0	21.01	20.37	19.09	21.45	22.3

Excess air (mol/mol, approximate)

From CO <sub>2</sub> + CO*	4.44	0.951	4.28	2.05	6.38	0.938
From O <sub>2</sub>	3.48	0.967	3.65	1.483	7.75	1.220
Assigned	3.96	0.959	3.97	1.775	7.07	1.079
Fuel/air	0.0185	0.0413	0.0186	0.0310	0.0118	0.0394

Molecular weight

	28.95	28.93	29			
Σ NO <sub>x</sub> (ppmv)	74.0	79.1	49.7	43.0	82.7	137.3

Emission index as NO<sub>2</sub>

Wet chemistry	6.45	3.16	4.32	2.27	11.25	5.75
Table IV, p. 61	5.50	2.97	3.76	1.81	12.03	5.46

\* It is assumed that analyses are on a dry basis. CO is negligible except in the fourth case, which is in question otherwise.

\*\* Calculated O<sub>2</sub> content in original air. Dry basis. Should equal 21.07.

Fuel was JP-4. The exhaust gases from the combustor (at 1200 K, 1700°F) passed through a choker, into a plenum (wherein ambient air was entrained), and through about 18 ft of a 12-in. duct prior to sampling [at about 933 K (1220°F)]. Samples were taken 3 in. and 18 in. downstream of the 18-in. duct. The temperature 3 in. downstream was about 847 K. These conditions were apparently intended to be indicative of the emissions in the free atmosphere behind an aircraft. Results from the AEDC group and from the Aeronutronic group are given in Table 2-3. Note that both UV and IR techniques implied a destruction of NO in sampling (even after passage through a choke and 18 ft of pipe, on which surface reactions could have taken place). Because conditions differed, it is difficult to compare these results to those obtained on the J93 engine by AEDC.

TABLE 2-3. COMPARISON OF OPTICAL AND PROBE MEASUREMENTS FOR NO USING A T-56 COMBUSTOR

<u>AEDC (UV) (Few et al., 1976)</u>			
	<u>Probe (ppmv)</u>	<u>Optical</u>	<u>Optical/Probe</u>
3 in. downstream	109	178	1.63
18 in. downstream	70	114	1.63
<u>Aeronutronic (IR) (Gryvnak and Burch, 1976)</u>			
	<u>Optical/Probe</u>		
Flat profile	1.24		
Bell profile	1.37		
Asymmetric	1.51		

A related study was carried out by Lyon et al., 1975; see also Lyon, 1975. In this work, a detailed study was made of emissions, both nonafterburning and from afterburning jet engines using J85 and J79 engines. Pollutant concentrations were obtained at the engine exit and at a variety of stations to 60 feet downstream. The effort used probe techniques only, but

these were used under the widely varying conditions between the engine exhaust plane and points downstream. While some anomalies were noted, no obvious change occurred in the  $\text{NO}_x$  emission index with distance downstream, with or without afterburning, leading the investigator to conclude that probe sampling gives accurate results, even under afterburning conditions. It is possible to interpret the same data in a somewhat different fashion, as is done in this report in Appendix A, with results that suggest, but do not prove, that reactions were taking place in the probe system, at least in some of the runs.

In another investigation carried out in 1974-1975 (Few et al., 1977), the validity of the UV analytical technique was studied by comparing NO measurements using UV and conventional methods on gases drawn through a probe; results were also obtained in-situ, on the hot gas stream.

The results, as indicated earlier and as shown in Fig. 2-1, showed excellent agreement downstream of the probe by conventional and in-situ spectroscopic techniques, but the values so obtained were about one-sixth those found in the free stream. The implication, if the UV technique is correct, is that some five-sixths of the free stream NO was destroyed in the sampling probe. The conditions used (about 600 K combustor inlet temperature, 55 psia, and fuel/air ratios of 0.01 to 0.05) correspond roughly to full power at about mach 0.9 and 36,000 ft, and were not exceptional; i.e., afterburning or high altitude, high mach number flight was not simulated. Furthermore, since a 6-fold ratio was found at the combustor exit, but a much smaller ratio implied at engine exit by the J93 data, it could be speculated that much NO created in the combustor is being destroyed in the turbine.

### 2.1.3 Related Investigations

The possibility that probe sampling of hot reactive gases can give erroneous results has been recognized for many years, and was almost certainly considered when developing ARP1256.

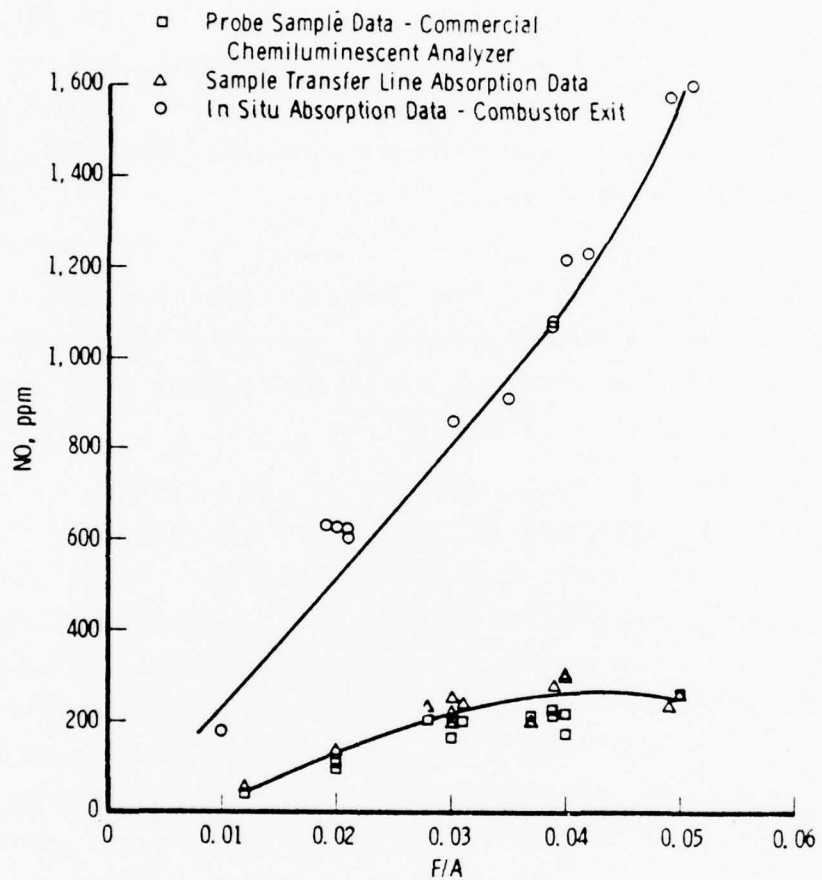

FIGURE 2-1. NO concentration as a function of the fuel-to-air ratio for turbine engine combustor exhaust obtained by various means.

Source: Few et al., 1977

Nevertheless, recently obtained results--in addition to those cited above--imply that much remains to be learned.\* A brief review follows.

Samuelson and Harman (1977) and Benson and Samuelson (1977) review past work and the possible homogeneous and heterogeneous reactions that can take place in sampling combustion gases containing nitrogen oxides (NO and NO<sub>2</sub>), and report on experiments involving mixtures of NO (500 ppm) and NO<sub>2</sub> (75 ppm) in an N<sub>2</sub> carrier gas containing various other gases (O<sub>2</sub>, CO<sub>2</sub>, H<sub>2</sub>, CO, CH<sub>4</sub>, C<sub>2</sub>H<sub>4</sub>, C<sub>3</sub>H<sub>6</sub>), with two probe materials (316 stainless steel and silica). A temperature range from 25 to 400° C was investigated. The following results seem to be of particular interest here:

1. In general, silica probes show less reactivity than stainless steel probes.
2. In many of the tests, NO<sub>2</sub> was converted to NO, but the sum of the two remained unchanged.
3. In O<sub>2</sub>-free mixtures containing H<sub>2</sub> or C<sub>3</sub>H<sub>6</sub> (but generally not with CH<sub>4</sub>, CO, or C<sub>2</sub>H<sub>4</sub>), NO<sub>x</sub> was removed, in some cases quantitatively, depending on reducing gas concentration, at temperatures of 400°C or lower, particularly over stainless steel. The concentrations used were 500 and 1000 ppm C<sub>3</sub>H<sub>6</sub>, and 0.5 to 3 percent H<sub>2</sub>.

These results are of considerable interest, indicating as they do the possibility of reactions taking place on the probe tips or in the sample lines. Of course, the mixtures used were not representative of typical combustor gases, lacking excess oxygen and combustion moisture. (Results with CO might have

---

\* Thus, while NO at room temperatures is known to be thermodynamically unstable, its kinetic stability is very great. Nevertheless, it can decompose slowly heterogeneously. Recently published data (Robertson et al., 1977), for example, show that NO in N<sub>2</sub> (250 to 1000 ppm) decomposes by 3.3 percent in 6-10 months in steel cylinders and by 3.8 percent in 17 months in commercial cylinders.

been different had  $H_2O$  been present, as water gas shift reactions could have resulted in  $H_2$  reactions with  $NO$ . Whether these would take place in oxygen-containing streams is unknown.)

Effects of probe materials and probe designs have also been studied recently at AEDC (R. Bryson).<sup>\*</sup> The probe designs used are shown in Fig. 2-2. An AVCO-Lycoming AGT-1500 combustor was used. This combustor, 5.5 inches in diameter and 12 inches long, was designed for use in a tank gas turbine, is symmetric in configuration, has a well-defined flow field and was thus considered particularly suitable for these tests. Results are shown in Table 2-4. Their results showed the following:

1. The quick-quench probe as recommended by GE (Lyon et al., 1975) gives lower  $NO$  values than the AEDC baseline probe, which latter involves a large sample tube and a noncritical pressure drop.
2. Baseline probe results were independent of tip material.
3. Strange results were evident for  $CO$ . High  $CO$  values were associated with low  $NO_x$ .  $CO$  values determined by probe, as well as  $NO$  values, thus appear to be in doubt.

UV results at these fuel-to-air ratios can be estimated roughly from Few et al. (1977), as being about 175 ppmv at 0.01, 605 ppmv at 0.02, and 860 ppmv at 0.03. The highest values found by probe at corresponding conditions (39 ppmv at 0.01, 133 ppmv at 0.02, 228 ppmv at 0.03) were always much lower than those estimated from UV spectrometry. It follows that probe design is important, but, particularly in light of independence of probe material, does not appear to explain the differences between the two methods.

In another AEDC study (Few, 1977) of particular interest to the subsonic aircraft case, optical  $NO$  measurements were made of the exhaust from an F-101-GE-100 engine at simulated altitudes,

---

<sup>\*</sup> Private communication October 11, 1977. See Bryson and Few, 1978.

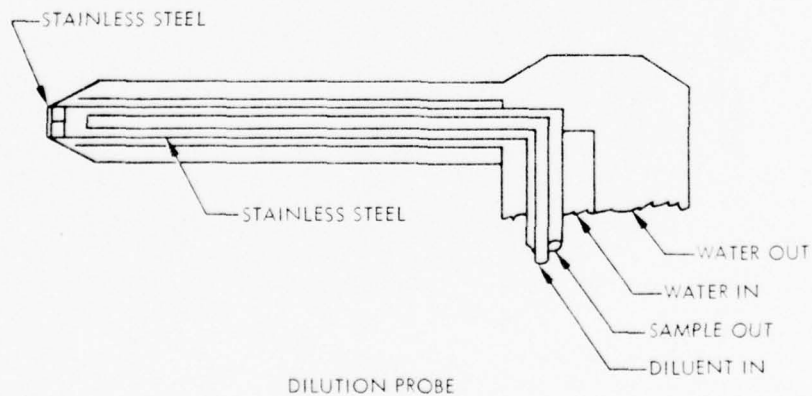
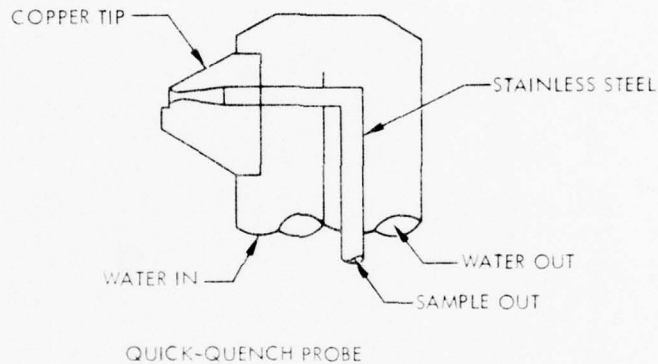
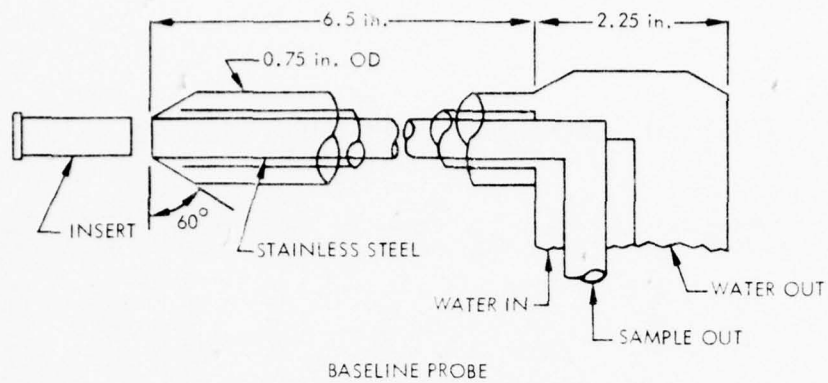

FIGURE 2-2. Sampling portions of the baseline, quick-quench and dilution probes.

Source: R. Bryson, AEDC



TABLE 2-4. COMPARISON OF EMISSIONS MEASURED WITH THE VARIOUS PROBES

Fuel-to-Air Ratio	Air Flow, km/sec	Combustor Pressure, kPa	Probe <sup>a</sup>	Sample Pressure Ratio <sup>b</sup>	Diluent Sample Ratio <sup>c</sup>	NO Content, ppmv	NO <sub>x</sub> Content, ppmv	CO Content, ppmv	CO <sub>2</sub> Content, Percent	C <sub>x</sub> H <sub>y</sub> Content, ppmc
0.010	0.816	265	BLSS	1.04	-	30	39	165	2.68	6
0.010	0.816	266	BLQ	1.08	-	33	43	155	2.79	4
0.010	0.821	265	BLC	1.04	-	32	43	165	2.77	4
0.010	0.821	265	QQ	1.93	-	26	33	116	2.07	29
0.010	0.816	263	QQ	4.96	-	25	32	126	2.07	16
0.010	0.816	262	DIL	4.87	0	29	34	131	2.22	8
0.010	0.816	262	DIL	2.57	1.43, N <sub>2</sub>	26	32	138	2.16	6
0.010	0.816	263	DIL	2.30	2.32, N <sub>2</sub>	13	13	70	1.03	47
0.010	0.816	263	DIL	2.37	1.50, A <sup>2</sup>	24	26	97	2.03	22
0.010	0.816	268	DIL	2.37	1.96, A	11	13	62	.83	15
0.010	0.816	263	DIL	3.00	1.70, He	32	37	113	2.32	16
0.010	0.816	263	DIL	2.23	3.36, He	31	38	131	2.14	4
0.020	0.816	311	BLSS	1.06	-	114	120	70	5.25	3
0.020	0.821	310	BLQ	1.12	-	114	129	85	5.27	0
0.020	0.816	311	BLC	1.06	-	118	133	70	5.33	0
0.019	0.821	311	QQ	2.29	-	73	92	272	4.02	11
0.019	0.821	309	QQ	5.91	-	71	90	307	4.02	11
0.020	0.816	309	DIL	5.82	0	78	96	490	4.18	5
0.020	0.821	309	DIL	3.01	1.36, N <sub>2</sub>	63	83	417	4.11	4
0.020	0.816	308	DIL	2.44	2.24, N <sub>2</sub>	44	60	315	3.21	4
0.020	0.816	308	DIL	2.76	1.42, A	59	75	460	3.85	3
0.020	0.816	308	DIL	2.51	1.94, A	39	51	335	2.70	2
0.020	0.816	308	DIL	3.52	1.56, He	69	91	574	4.33	3
0.020	0.816	308	DIL	2.60	3.09, He	63	91	535	4.29	0
0.030	0.821	347	BLSS	1.07	-	192	205	124	6.63	0
0.030	0.816	346	BLQ	1.15	-	198	221	165	7.03	0
0.030	0.816	347	BLC	1.08	-	202	228	190	6.93	0
0.030	0.816	346	QQ	2.00	-	128	163	1878	5.91	8
0.030	0.816	345	QQ	5.21	-	134	163	3140	5.72	14
0.030	0.816	345	QQ	6.51	-	136	164	3242	5.72	14
0.030	0.816	343	DIL	6.72	0	148	172	4900	5.86	20
0.030	0.816	341	DIL	3.54	1.38, N <sub>2</sub>	124	147	3976	5.47	33
0.030	0.816	342	DIL	2.74	2.35, N <sub>2</sub>	110	133	5753	5.26	74
0.030	0.821	343	DIL	3.21	1.50, A <sup>2</sup>	114	130	4010	5.25	25
0.030	0.816	342	DIL	2.76	2.02, A	101	116	3985	4.83	49
0.030	0.816	343	DIL	4.11	1.73, He	141	174	6008	6.12	55
0.030	0.816	341	DIL	3.06	3.23, He	129	160	5191	5.75	51
0.024	0.821	327	BLSS	1.07	-	169	177	80	6.27	1
0.025	0.816	329	BLQ	1.15	-	175	191	85	6.44	0
0.025	0.821	328	BLC	1.07	-	174	194	75	6.38	0
0.024	0.816	327	QQ	1.92	-	106	136	856	5.20	8
0.025	0.816	329	QQ	3.91	-	106	134	1052	5.16	15
0.025	0.816	329	QQ	6.28	-	103	132	1148	4.99	8
0.025	0.816	329	DIL	6.29	0	126	147	2400	5.32	10
0.025	0.821	329	DIL	3.24	1.42, N <sub>2</sub>	102	132	2124	5.23	14
0.025	0.816	329	DIL	2.59	2.29, N <sub>2</sub>	87	112	1848	4.74	26
0.025	0.816	328	DIL	2.99	1.48, A <sup>2</sup>	94	112	1891	4.79	10
0.025	0.816	329	DIL	2.65	1.94, A	83	99	1696	4.26	14
0.025	0.816	327	DIL	3.33	1.66, He	115	142	2333	5.43	21
0.025	0.816	327	DIL	2.93	3.09, He	102	134	2078	5.15	16

- a. BLSS - Baseline with stainless steel surface      QQ - Quick quench  
 BLQ - Baseline with quartz surface                      DIL - Dilution  
 BLC - Baseline with copper surface
- b. Sample pressure ratio is ratio of combustor pressure to sample line pressure
- c. Diluent - Sample ratio is the ratio of the volume flow rate of diluent gas to the volume flow rate of sample

under subsonic conditions, and as a function of distance from the centerline. Unfortunately, probe results were not taken in the same test, but extrapolations were made from probe results (an orifice-type probe) taken on a similar engine earlier. The results are shown in Fig. 2-3. Note that a rapid drop-off in NO occurs with distance from centerline. The apparent agreement between probe values and optical values at larger radii is perhaps misleading due to the extrapolation procedure used; in addition, mass flux as a function of radius is unknown, so that it is impossible to obtain a reliable estimate of total NO<sub>x</sub> flux by the two methods, although this would be of interest. If, however, uniform mass flux per unit area is assumed, and the plot accepted as drawn, the mass weighted emissions by optical techniques would be about 35-40 percent above these by probe.

An optical procedure was also used in an attempt to measure NO<sub>2</sub>. No discernible absorption was found, indicating, for the setup used, less than 20 ppmv of NO<sub>2</sub>. It was concluded that most of the NO<sub>x</sub> is as NO.

The above results suggest significant difficulties in using probe-sampling techniques, although there is no proof that the spectroscopic values are correct; there are other additional, somewhat fragmentary, data which tend to confirm these difficulties and indicate the need for further work. Thus, Seery and Zabielski (1977), in reporting on work carried out to study chemistry in flames (rather than on measurement methods per se), give a comparison of NO content in a flame formed by methane and air (stoichiometric at 0.1 atm), as measured by molecular beam samples (with mass spectroscopy) and by a quartz microprobe. The microprobe samples were found to show far lower (factors of 5-10) NO values than those found by the molecular beam system.

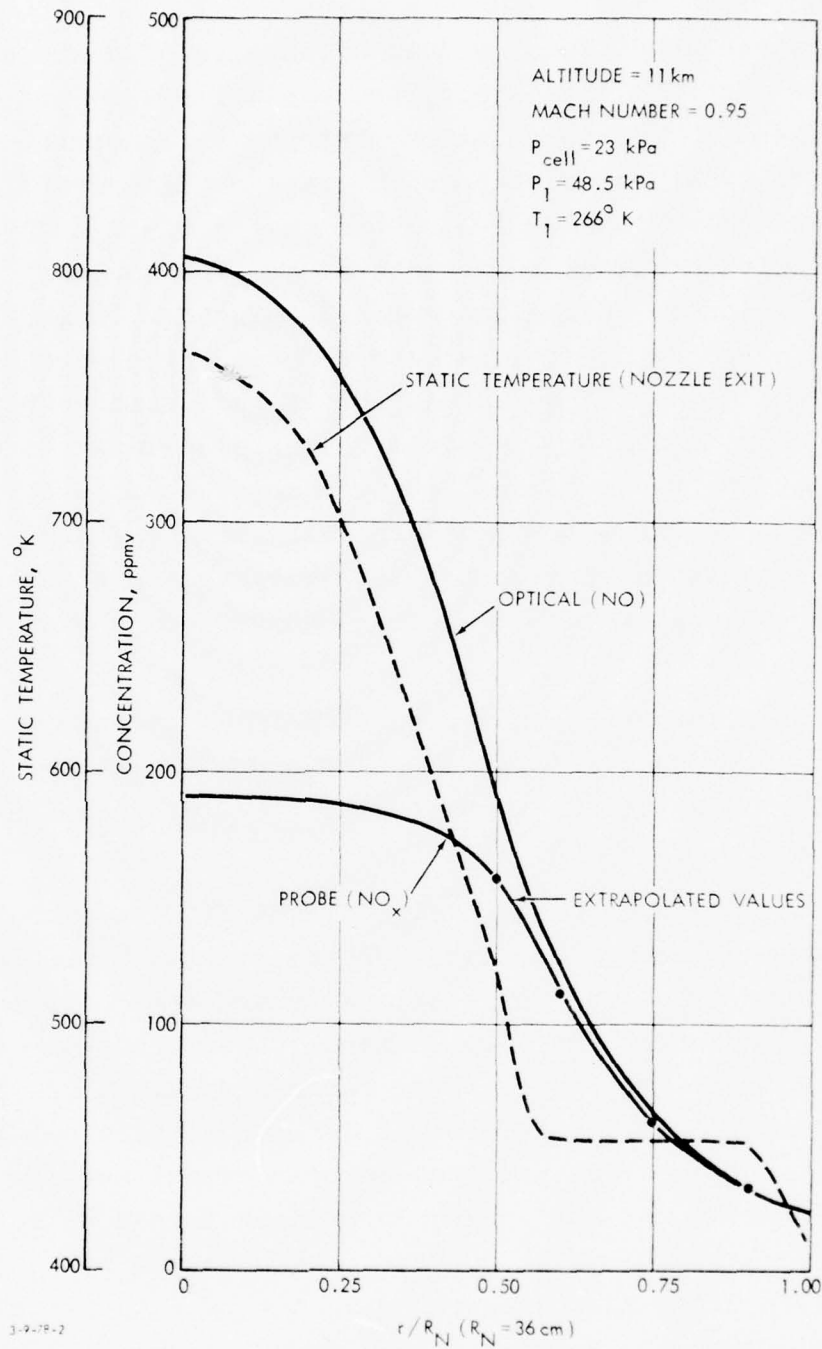

FIGURE 2-3. NO concentrations and static temperature profiles. Intermediate power. The NO concentration values shown are at 10.2 cm downstream. The probe values shown have been extrapolated (with uncertainties introduced) from measurements at other conditions. The temperature profile shown is at the nozzle exit.

Source: Few (1977)

A related investigation is underway in which measurement methods are at issue. No conclusive results are yet available, but some questions about the accuracy of the ultraviolet spectroscopic technique as developed at AEDC have arisen (M.F. Zabielski, private communication, 1978); it does not appear, however, that the uncertainties at issue would account for a six-fold difference, as found at AEDC in some investigations. (See Fig. 2-1.) This preliminary finding may be important and may, in concert with the probe studies, indicate that both the probe and spectroscopic results have been in some error.

Returning to probe questions, there is also recent evidence that heterogeneous processes may enter, which could be involved on uncooled parts in sampling afterburning mixtures or could take place with soot particles carried in the hot stream. Thus, Myerson (1978) found that a pyrolytic type of carbonaceous deposit, highly reactive to NO decomposition, could be formed on the walls of a ceramic reactor being used in the study of homogeneous reduction of NO by hydrocarbons (as in auto exhaust mixtures) at temperatures of the order of 1400-1500°C. The oxygen in the NO appeared as CO, the nitrogen as N<sub>2</sub>. The input gases in the experiments typically involved mixtures in N<sub>2</sub> containing 0.4 percent i-C<sub>4</sub>H<sub>10</sub>, 0.4 percent O<sub>2</sub>, and NO at the level of 1000 ppm. These conditions, of course, do not exist in usual jet engine streams, although soot is always present to some degree. Myerson also refers to earlier work which showed that graphite resistant to attack by oxygen would react with NO (at 1233 K). The homogeneous reactions are, of course, also of interest, with Samuelson's work already cited. Presumably, analogous processes were involved in work of Sugiyama et al. (1978) which showed that fuel-bound nitrogen is converted to N<sub>2</sub> in the presence of small amounts of O<sub>2</sub> during pyrolysis at 600-800°C.

Finally, in still another investigation, two sources of error in chemiluminescence methods have been studied by Mathews

et al. (1977). These have to do with relative quenching efficiencies of different third bodies--water vapor showing a high quenching efficiency, for example. It appears that errors of 20 percent or so may be involved with different mixtures of combustion gases. In addition, the possibility exists that other nitrogen-containing gases may be converted to NO in the analyzer. Obviously, the questions involved merit attention in any measurement program using these techniques.

#### 2.1.4 Significance: A Probable Upper-bound Estimate of NO<sub>x</sub> Emission Index of Concorde

The significance of the NO<sub>x</sub> measurement uncertainty to HAPP obviously relates to the question of how many aircraft would cause a specified effect. What would be needed in order to bound such effects are measurements using a validated UV spectrometric technique (if probes are shown to be unreliable on existing engines under appropriate operating conditions rather than on combustors or other research-type setups). In the absence of such information, the significance must be determined indirectly. In doing so, it must be considered that, at present, both probe and UV spectrometer data are suspect, and ratios of the two techniques cannot necessarily be applied from engine to engine.

The first comparison of interest is that of the emission index data derived from the T-56 combustor test (Few et al., 1977) to that obtained from engine tests (Davidson and Domal, 1973) both at AEDC, as shown in Table 2-5. The nonafterburning case at military power is used. Here, the engine tests, even when conducted under considerably more severe conditions,\* give

---

\* According to Davidson and Domal (1973), the NO<sub>x</sub> emission index increases by the 2.5 power of the combustor inlet temperature. The emission index for the T-56 combustor at 800 K inlet would, by this relationship, be twice that at 600 K, or about 100 gm NO<sub>2</sub>/kg fuel by UV techniques, using the data in Table 2.5. This value (100) is about half the equilibrium value for dry air, at this inlet temperature, at an equivalence ratio of 0.9 (Blazowski et al., 1975).

lower emission indices by spectroscopic techniques than were obtained at the output of the combustor for the combustor tests using the same technique. This would seem to imply that considerable  $\text{NO}_x$  reduction takes place in the turbine (which seems doubtful).

TABLE 2-5.  $\text{NO}_x$  EMISSION INDEX DATA COMPARISONS

<u>T-56 Combustor Test (Few et al., 1977)</u>					
Temperature Inlet, K	Pressure Inlet, psia	f/a	$\text{NO}_x$ E.I. (as $\text{NO}_2$ ) <sup>a</sup>		
			(Probe)	(In-Situ)	
598	56.4	0.010	4.8	28.0	
598	46.2	0.020	8.3	48.9	
600	54.4	0.030	10.4	46.8	
604	52.1	0.040	8.9	50.3	
605	57.0	0.051	8.6	52.3	

<u>J93 Engine Test (Davidson and Domal, 1973)</u>					
Temperature Inlet, K <sup>b</sup>	Pressure Inlet, psia <sup>b</sup>	f/a	$\text{NO}_x$ E.I. (as $\text{NO}_2$ )		Comment
			(Probe)	(In-Situ) <sup>c</sup>	
590	82	0.0211	4.60	6.04	Mach 1.4, 35,000 ft
672	53	0.0196	6.70	14.90	Mach 2.0, 55,000 ft
800	59	0.0150	12.03	35.9	Mach 2.6 66,000 ft

<sup>a</sup>Based on NO alone.  $\text{NO}_2$  data are not reported but should be negligible.

<sup>b</sup>From Fig. 12, p. 44 (graphical) Davidson and Domal (1973).

<sup>c</sup>These values are derived from the reported NO ratios and the  $\text{NO}_x$  emission indices from probe measurements, assuming the  $\text{NO}_2$  component is constant.

As another comparison of interest, the J93 data can be compared to the Concorde data (CIAP Monograph 2, pp. 4-34), as in Table 2-6. Note that the J93 probe data, if converted to conditions used in the Concorde, agree well with Concorde probe

data (16.7 vs. 16.8). Also, if the spectroscopic data are correct, and emission index (E.I) of about 50 gm NO<sub>2</sub>/kg fuel might be assigned to the Concorde at cruise. The agreement in probe results is somewhat surprising in that the probe data obtained by AEDC were apparently somewhat (~ 10 percent) low compared to other turbojet data. (See Davidson and Domal, 1973, p. 52.)

TABLE 2-6. COMPARISON OF CONCORDE (PROBE) AND J93 NO<sub>x</sub> RESULTS

Temperature Inlet, K	Pressure In- let, psia	f/a	NO <sub>x</sub> E.I.		(Test No.); Conditions
			(Probe)	(UV)	
<u>Concorde</u>					
801	102	0.0147	16.8		(4) Mach 1.99 58,879 ft, ISA-9 K
824	95	0.0141	17.7		(7) Mach 2.00, 58,000 ft, ISA+5 K
<u>J93 (measured)</u>					
800	59	0.0150	12.0	35.9	Mach 2, 55,000 ft
<u>J93 (converted to Concorde conditions)*</u>					
800	102	0.0150	16.7	49.9	

\* Estimated values, assuming P<sup>0.6</sup> dependence based on results presented by Blazowski et al., 1975; prorating the quoted results at 59 psia.

## 2.2 FLEET FORECASTS OR PROJECTIONS

Fleet forecasting, the problems inherent in it, and in the fleet figures generated thereby, have been discussed in earlier reports (see Oliver et al., 1977, Pozdena 1976, Athens et al., 1976, CIAP Monograph 2, 1975) and will not be discussed in detail here. Nevertheless, it is of some interest to consider two papers which have become available since our previous report. One of these, *Aviation Futures to the Year 2000* (published by the Department of Transportation, FAA, February 1977), was

sponsored by the FAA; the other, Geddes (1977), is a projection by McDonnell-Douglas, updating similar earlier publications.

In *Aviation Futures*, five scenarios are assumed, consideration being given "almost exclusively" (not further defined) to the U.S. fleet. The scenarios are based on sets of assumptions as to population, business productivity, cost of domestic crude, etc. Certain data extracted from the report are given in Table 2-7. Note that SST traffic is included only in the most optimistic "expansive growth" scenario. Note also the assumed prices of oil: in the "muddling through" scenario, with \$14 oil, the jet fuel consumption is less in the year 2000 than at present.

TABLE 2-7. UNITED STATES; YEAR 2000 ESTIMATES\*

Key Variables	1974	Limited Growth	Muddling Through	Resource Allocation	Individual Allowance	Expansive Growth
Population (millions)	212	250	297	250	250	297
Gross National Product 10 <sup>12</sup> 1973 dollars	1.3	1.9	2.1	2.9	4.1	4.3
Cost of Domestic Crude 1973 dollars/barrel	11.0	8.5	14.0	8.0	6.0	7.5
Enplaned Passengers Millions/yr.	207	406	272	471	788	1113
Total Revenue Passenger Miles Billions/yr.	131	259	167	304	485	597
Jet Fuel Consumption Millions of barrels/yr.	190	317	158	317	517	850
Carrier Fleet Total Aircraft	2420	3790	2430*	3540	5660	7670
Mix (percentage)						
747-type		5	4	8	9	10
707-type		0	4	0	0	0
DC-10 type		18	12	20	17	20
727-type		62	64	59	55	41
Small (50 passengers)		15	16	10	11	9
SST		0	0	0	0	3
Large (1000 passengers)		0	0	3	3	4
Jet STOL (150 passengers)		0	0	4	5	13

Source: FAA, 1977

\* 2670 in 1985



Direct comparison of the *Aviation Futures* results with those of McDonnell-Douglas (Geddes) is difficult, as time periods differ, some questions arise as to what is included in the two forecasts, and there is a difference in focus, one (Geddes) emphasizing passenger miles and the other passenger enplanement and operations. Nevertheless, some figures have been developed for comparison of the two sources, as shown in Table 2-8.

TABLE 2-8. FLEET COMPARISONS

	<u>1985</u>	<u>1990</u>	<u>2000</u>
Total Aircraft			
Aviation Futures ("Expansive U.S.")	3890	--	7670
McDonnell-Douglas (world)	7217	7908	--
McDonnell- Douglas (U.S.) <sup>1</sup>	3115	3270	--
SSTs			
Aviation Futures ("Expansive U.S.") ~	20	(100) <sup>2</sup>	230
McDonnell-Douglas (world)	16	118	--
U.S. Passenger Miles/yr. (Billions)			
Aviation Futures ("Expansive U.S.") ~	260 <sup>3</sup>	~ 350 <sup>3</sup>	597 <sup>3</sup>
McDonnell-Douglas	302	~ 380	--

<sup>1</sup>Prorating U.S. numbers by U.S. share of world schedule/passenger-miles.

<sup>2</sup>Interpolated

<sup>3</sup>In this scenario, a rapid growth in jet STOL takes place between 1985 and 2000, reducing average passenger-miles per enplanement. The approximate figures shown were estimated by this author, assuming 630, 585, and 540 (their numbers) miles per trip average in the respective years.

The McDonnell-Douglas projections show a new SST introduced in 1986. The *Aviation Futures* document does not indicate the SST types. *Aviation Futures* shows a 1000-passenger plane to be in operation (~ 40) in the expansive-growth scenario by 1985; McDonnell-Douglas does not include such a craft.

### 2.3 CONCORDE EMISSIONS ESTIMATES

In a previous report (Oliver et al., 1977),  $\text{NO}_x$  emission estimates were provided for the Concorde aircraft as well as for a "1990-High" estimate of a world fleet. No new world fleet results are available, but new estimates have been provided for the Concorde by P.C. Beadle of the British Aircraft Corporation (Beadle, 1977). The new estimates are for only a nine-aircraft fleet, but cover a wide network, and are the only estimates available for the full altitude-latitude range. The data are still subject to adjustment, as certain approximations have been made in treating the various atmospheres at different latitudes. Nine aircraft, of course, are of little environmental significance, but the distribution may be of interest to traffic modelers.

The network Beadle studied is that planned "for likely operation" in 1978-1979. The route network shown in Table 2-9 is served by nine aircraft, totaling 57.5 hours daily usage, from 6.4 hours per aircraft per day (or 2330 hours each per year).

The  $\text{NO}_x$  (as  $\text{NO}_2$ ) emission index data used by Beadle is shown in Table 2-10. These were generated by him and involve a much larger correction to zero humidity than used by Scott (1974) or recommended by Blazowski et al. (1975), so that the emission index values at cruise are 20-40 percent higher than given previously by Scott. Beadle argues that his correction gives a better fit to available data for supersonic flight conditions.\* Other emission indices recommended by Beadle are given in Table 2-11; the data are from COMESA (1975).

---

\* Beadle's correction seems excessive in view of the data reported by Scott where an 80 percent reduction in inlet humidity resulted in an increase from 17.7 to 18.4 to 19.3  $\text{kg}/\text{NO}_2/\text{gm}$ . Scott corrected for the remaining 20 percent water with a 3 percent further increase. Beadle's (continued)

TABLE 2-9. CONCORDE ROUTE NETWORK SUMMARY

Route		Distance,	Flight Time,	Fuel,	Weekly
<u>Origin</u>	<u>Destination</u>	<u>nmi</u>	<u>minutes</u>	<u>kg</u>	<u>Frequency</u>
London	Washington	3,306	222	73,591	7
	New York	3,060	203	69,385	14
Washington	Bahrain	3,056	222	75,115	4
	London	3,423	209	77,945	7
New York	Paris	3,546	215	79,853	7
	London	3,115	189	68,059	14
Bahrain	Paris	3,266	201	69,964	14
	London	3,070	235	73,709	4
Paris	Singapore	3,624	235	77,785	3
	Washington	3,464	226	80,971	7
Singapore	New York	3,221	208	76,774	14
	Dakar	2,485	171	58,520	2
Dakar	Santa Maria	1,474	119	35,760	1
	Bahrain	3,640	220	79,866	3
Santa Maria	Melbourne	3,387	221	77,310	3
	Paris	2,512	166	54,260	2
Melbourne	Rio de Janeiro	2,789	180	63,192	2
	Paris	1,454	111	32,315	1
Rio de Janeiro	Caracas	2,785	175	61,025	1
	Singapore	3,353	223	78,994	3
Caracas	Dakar	2,779	173	60,849	2
	Buenos Aires	1,150	88	33,013	2 (1979)
Buenos Aires	Santa Maria	2,793	172	60,195	1
	Rio de Janeiro	1,150	87	29,481	2 (1979)

Source. Beadle, 1977

correction for the remaining 20 percent of water is 25 percent or more, which is difficult to understand in view of Blazowski's theoretical arguments (Blazowski, 1975). Blazowski suggests that the difference in NO<sub>x</sub> emission index between air at 300 ppm and air at 3 ppm at stratosphere conditions should be about 1/2 percent.

TABLE 2-10. EMISSION INDICES FOR CONCORDE (g NO<sub>2</sub>/kg Fuel)

Takeoff and Subsonic Climb	Subsonic Cruise	Transonic Acceleration	Descent and Landing	Supersonic Cruise - Climb					
				ISA	ISA - 5	ISA - 10	ISA-15	ISA - 20	
13.1			3.8						
16.8			3.4						
16.5			3.2						
16.2			3.1						
15.9			3.0						
15.6			2.8						
15.3			2.7						
15.0	10.0	13.2	2.6						
	8.7	11.0	2.4						
	7.3	10.8	2.3						
	5.9	10.7	2.5						
	4.5	11.2	2.7						
		14.6	2.9						
			3.2	25.7	24.9	24.0	23.7	23.4	
			3.5	27.8	26.9	25.8	25.4	25.1	
			3.8	29.6	28.7	27.7	27.3	26.9	
			4.3	27.3	26.4	25.5	25.1	24.8	
			4.8	25.1	24.3	23.3	23.0	22.8	
			5.2	23.9	23.1	22.2	21.9	21.7	

Source: Beadle, 1977

TABLE 2-11. CONCORDE EMISSION INDICES (OTHER THAN NO<sub>x</sub>, SO<sub>2</sub>)  
 Source: Beadle, 1977

<u>Emissions other than NO<sub>x</sub></u>	<u>Emission Index (g/kg fuel)</u>
Water Vapor	1270
Carbon dioxide	3140
Carbon monoxide	3.5
Unburnt hydrocarbons	0.2
Particulates	0.1

Beadle's analysis (like Scott's) was based on use of an International Standard Atmosphere (which is the same as the U.S. Std. Atm. 1976 for purposes here) plus-or-minus varying increments in temperature, with the standard atmosphere assumed for the troposphere (to 13 km) and a uniformly cooler or warmer atmosphere above, rather than standard atmospheres for other latitudes. Some uncertainty is recognized in so doing, but the resulting estimates should still be suitable for modeling purposes, in view of the other uncertainties involved.

The Concorde is limited to a pressure altitude of 18.3 km or 60,000 ft (Scott, 1974), or about 72 mbar. The geometric altitude resulting varies with season and latitude from about 17.6 km (arctic winter) to about 18.6 km (30°N in summer).

Beadle gives fuel flows and NO<sub>x</sub> (as NO<sub>2</sub>) emissions from 0 to 19 km by 1-km bands and from 40°S to 55°N by 5° latitude bands. His results are given in Tables 2-12 and 2-13.

Beadle also analyzes normalized emissions by altitude bands in the stratosphere (15-16, 16-17, 17-18 km) as done earlier by Oliver et al. (1977, pp. 2-32) in adjusting A.D. Little (Athens et al., 1976) estimates. Beadle finds Oliver's adjusted values agree reasonably well with his estimates, if taken to apply to the Northern Hemisphere wherein most of the traffic lies. However, surprisingly large relative amounts of NO<sub>x</sub> enter the 18-19 km

TABLE 2-12. FUEL FLOW FOR A NINE-CONCORDE FLEET. kg/WEK. Source: Beadle, 1977

Alt. km.	0	1	2	3	4	5	6	7	8	9	10	11	12	13	14	15	16	17	18	19	20	21	22	23	24	25	30	3.5	4	4.5	5	5.5					
0 - 1	-	23056	-	6570	-	-	-	-	-	-	-	-	-	-	-	-	-	-	-	-	-	-	-	-	-	-	-	-	-	-	-	-	-	-	-		
1 - 2	-	8170	-	3968	-	-	-	-	-	-	-	-	-	-	-	-	-	-	-	-	-	-	-	-	-	-	-	-	-	-	-	-	-	-	-	-	
2 - 3	-	3170	-	4024	-	-	-	-	-	-	-	-	-	-	-	-	-	-	-	-	-	-	-	-	-	-	-	-	-	-	-	-	-	-	-	-	
3 - 4	-	2920	-	3964	-	-	-	-	-	-	-	-	-	-	-	-	-	-	-	-	-	-	-	-	-	-	-	-	-	-	-	-	-	-	-	-	
4 - 5	-	3520	-	3844	-	-	-	-	-	-	-	-	-	-	-	-	-	-	-	-	-	-	-	-	-	-	-	-	-	-	-	-	-	-	-	-	
5 - 6	-	3170	-	3764	-	-	-	-	-	-	-	-	-	-	-	-	-	-	-	-	-	-	-	-	-	-	-	-	-	-	-	-	-	-	-	-	
6 - 7	200	2970	-	3924	-	-	-	-	-	-	-	-	-	-	-	-	-	-	-	-	-	-	-	-	-	-	-	-	-	-	-	-	-	-	-	-	
7 - 8	15650	7720	-	4364	-	-	-	-	-	-	-	-	-	-	-	-	-	-	-	-	-	-	-	-	-	-	-	-	-	-	-	-	-	-	-	-	
8 - 9	3710	1950	-	5762	-	-	-	-	-	-	-	-	-	-	-	-	-	-	-	-	-	-	-	-	-	-	-	-	-	-	-	-	-	-	-	-	
9 - 10	4570	100	-	6882	-	-	-	-	-	-	-	-	-	-	-	-	-	-	-	-	-	-	-	-	-	-	-	-	-	-	-	-	-	-	-	-	
10 - 11	6570	-	-	6842	-	-	-	-	-	-	-	-	-	-	-	-	-	-	-	-	-	-	-	-	-	-	-	-	-	-	-	-	-	-	-	-	
11 - 12	18000	-	-	6922	-	-	-	-	-	-	-	-	-	-	-	-	-	-	-	-	-	-	-	-	-	-	-	-	-	-	-	-	-	-	-	-	
12 - 13	6200	-	3920	4222	-	-	-	-	-	-	-	-	-	-	-	-	-	-	-	-	-	-	-	-	-	-	-	-	-	-	-	-	-	-	-	-	
13 - 14	1920	-	3500	2862	-	-	-	-	-	-	-	-	-	-	-	-	-	-	-	-	-	-	-	-	-	-	-	-	-	-	-	-	-	-	-	-	
14 - 15	9330	4940	3500	3482	-	-	-	-	-	-	-	-	-	-	-	-	-	-	-	-	-	-	-	-	-	-	-	-	-	-	-	-	-	-	-	-	
15 - 16	650	24420	3600	1144	3180	-	-	-	-	-	-	-	-	-	-	-	-	-	-	-	-	-	-	-	-	-	-	-	-	-	-	-	-	-	-	-	
16 - 17	600	10340	27900	18194	12420	-	-	-	-	-	-	-	-	-	-	-	-	-	-	-	-	-	-	-	-	-	-	-	-	-	-	-	-	-	-	-	
17 - 18	2750	14200	31400	18194	43150	54560	35190	7590	15100	29150	50465	16400	29650	43150	87685	32035	293707	759170	16702	827768	-	-	-	-	-	-	-	-	-	-	-	-	-	-	-	-	
18 - 19	2400	23250	4350	5950	5070	12000	30160	20500	65940	5075	31000	24400	16400	9968	-	-	-	-	-	-	-	-	-	-	-	-	-	-	-	-	-	-	-	-	-	-	
Total	80600	162206	77220	114596	69820	66550	88009	69750	102987	249640	136373	102870	119665	215032	168200	519030	180808	2741001	528086	8912000	-	-	-	-	-	-	-	-	-	-	-	-	-	-	-	-	
%	.95	1.61	.91	1.36	.76	.79	1.05	.83	1.22	2.96	1.62	1.22	1.37	2.55	1.96	6.15	22.12	32.47	16.10	-	-	-	-	-	-	-	-	-	-	-	-	-	-	-	-	-	
0 - 11	30700	59056	-	53845	-	-	-	-	3000	54777	22650	56653	2960	5790	97246	-	-	-	-	-	-	-	-	-	-	-	-	-	-	-	-	-	-	-	-	-	25.3
11 - 14	34120	-	6420	14006	-	-	-	-	14100	1296	14400	16675	9300	12210	26693	-	-	-	-	-	-	-	-	-	-	-	-	-	-	-	-	-	-	-	-	10.3	
14 - 19	15780	77150	79800	56654	63820	66550	88000	92660	10591	212800	67035	90810	97965	91093	103200	154105	1696607	215742	952544	5438619	-	-	-	-	-	-	-	-	-	-	-	-	-	-	-	61.4	
%	.29	1.42	1.30	.86	1.17	1.22	1.63	.97	.68	3.91	1.16	1.68	1.80	1.67	3.04	2.83	18.51	36.90	16.96	-	-	-	-	-	-	-	-	-	-	-	-	-	-	-	-		

WP/7075

TABLE 2-13. NO<sub>x</sub> EMISSIONS (g NO<sub>2</sub>/DAY) FOR A NINE-CONCORDE FLEET,  
ANNUAL AVERAGE TEMPERATURES

Altitude, km	Latitude, Northern Hemisphere										Latitude, Southern Hemisphere													
	0	5	10	15	20	25	30	35	40	45	50	55	0	5	10	15	20	25	30	35	40	45	50	55
0 - 1	37,429.	0.	7,178.	0.	0.	32,808.	0.	56,107.	129,743.	64,594.	164,201.													
1 - 2	21,630.	0.	8,956.	0.	0.	18,402.	0.	38,810.	83,056.	57,772.	42,743.													
2 - 3	8,764.	1,697.	8,869.	0.	0.	12,970.	0.	38,159.	85,190.	59,967.	39,579.													
3 - 4	4,435.	4,791.	8,769.	0.	0.	12,730.	0.	37,437.	79,804.	59,986.	35,962.													
4 - 5	5,031.	4,702.	9,025.	0.	0.	12,431.	0.	36,890.	76,938.	55,833.	34,586.													
5 - 6	4,924.	4,613.	8,668.	0.	0.	12,242.	0.	36,076.	75,320.	53,456.	35,458.													
6 - 7	4,825.	4,459.	8,270.	0.	0.	12,003.	0.	37,389.	78,138.	54,372.	34,764.													
7 - 8	5,600.	3,847.	9,346.	0.	0.	13,548.	0.	43,274.	131,279.	177,066.	36,343.													
8 - 9	6,337.	3,206.	8,707.	0.	0.	14,453.	0.	34,235.	74,454.	48,312.	78,893.													
9 - 10	6,217.	7,406.	10,125.	118.	4,212.	9,974.	0.	31,018.	73,131.	57,833.	46,468.													
10 - 11	905.	7,337.	7,391.	3,506.	4,677.	12,454.	0.	31,061.	77,729.	89,285.	74,539.													
11 - 12	236.	7,680.	6,350.	4,634.	4,848.	13,683.	0.	36,174.	121,108.	46,688.	76,850.													
12 - 13	167.	10,011.	12,048.	6,423.	6,320.	17,781.	0.	45,205.	106,879.	25,556.	102,717.													
13 - 14	129.	16,046.	14,743.	7,937.	20,822.	27,488.	0.	242,970.	207,385.	291,640.	291,718.													
14 - 15	141.	17,211.	18,730.	15,308.	23,524.	29,453.	5,086.	108,116.	611,718.	267,356.	592,389.													
15 - 16	153.	64,675.	3,371.	22,434.	105,048.	65,964.	19,717.	3,051.	1,239,211.	212,860.	2,180,807.													
16 - 17	481.	163,574.	3,316.	114,704.	34,579.	20,391.	224,181.	343,634.	722,828.	4,796,060.	890,771.													
17 - 18	257,803.	257,803.	163,047.	53,848.	94,989.	168,559.	291,308.	109,506.	1,030,273.	2,690,867.	60,366.													
18 - 19	63,550.	204,414.	15,732.	96,543.	76,337.	51,543.	31,603.	0.	26,241.	6,297.	0.													

band, differing from earlier estimates. Because such distributions are sensitive to the assumptions made in treating the atmospheric temperature profile, such discrepancies may not be surprising (or, probably, too important).

The  $\text{NO}_x$  emissions shown by Beadle are almost certainly too small to be noticeable in a computer perturbation study. A 50-fold increase (corresponding to 450 aircraft) would perhaps be appropriate for modeling purposes for accuracy; however, to test possible nonlinearities (see Section 3.5.5), several fleet sizes would need to be examined.

The Beadle results just shown are nominally for geometric altitude models. Resolution is probably such, however, that little additional uncertainty will be introduced if these distributions are used in pressure coordinate models. It is important to recognize that a substantial part of the total emissions is released in climbing to altitude, so that models assuming aircraft at a single altitude may give misleading results.

#### 2.4 $\text{NO}_x$ EMISSION REDUCTION EFFORTS

The CIAP (Grobecker et al., 1974) and NAS (1975) studies indicated that both subsonic and supersonic aircraft would reduce the ozone layer if fleet growth were to continue as then expected unless  $\text{NO}_x$  emission indices are substantially reduced (6-fold or more). This goal thus became an add-on to efforts which had been underway for some time to reduce emissions at takeoff and landing, based on EPA proposed standards, and programs were initiated under NASA sponsorship. All these efforts were reviewed in a conference held at NASA Lewis in May 1977 (Aircraft Engine Emissions, 1977). The Stratospheric Cruise Emission Reduction Program (SCERP) (Diehl et al., 1977, op.cit.) is of particular interest. Much of the "clean combustor" work directed to EPA goals is of general technical interest, but the modest reductions achievable by the combustor modifications



being investigated (2-fold perhaps) make them poor candidates for the bold reductions called for in CIAP and by the NAS (which goals, of course, were set by the stratospheric chemistry then employed and will not be reviewed here). This is not to say that these more modest goals, with their perhaps more practical approaches, will not eventually find use at cruise conditions. All  $\text{NO}_x$  values reported in the conference were based on standard probe-sampling techniques.

Diehl (1977) provides a plot (Fig. 2-4) which summarizes the "outlook" for both subsonic and supersonic cruise. Several points should be noted:

1. The inapplicability of clean combustor technology to the expressed goals is clear.
2. For advanced SSTs, the great *increase* in  $\text{NO}_x$  emission index using conventional combustors is due to expected higher combustor pressures and temperatures, presumably called for by efforts to achieve lower specific fuel consumption at cruise. Note that the mach 2.32 aircraft at 52,000 feet (16 km) design condition flies lower and faster than Concorde. Clean combustor technology would be required to maintain future  $\text{NO}_x$  emission indices at current levels.
3. The recommended levels of  $\text{NO}_x$  emissions are approached or achieved by "forced circulation," lean premix-prevaporize (LPP), and catalytic techniques. The problems in achieving a practical engine using any of these techniques are severe; those using a catalyst are probably the most severe, although some hybrid system, using a catalyst as an ignitor, may be promising. The LPP system has been investigated to the greatest degree.

The problems associated with the LPP technique include questions of fuel-air mixing, flashback, variable geometry, auto-ignition, narrow operating limits (in terms of stoichiometry),

### SUBSONIC CRUISE NO<sub>x</sub> EMISSION OUTLOOK

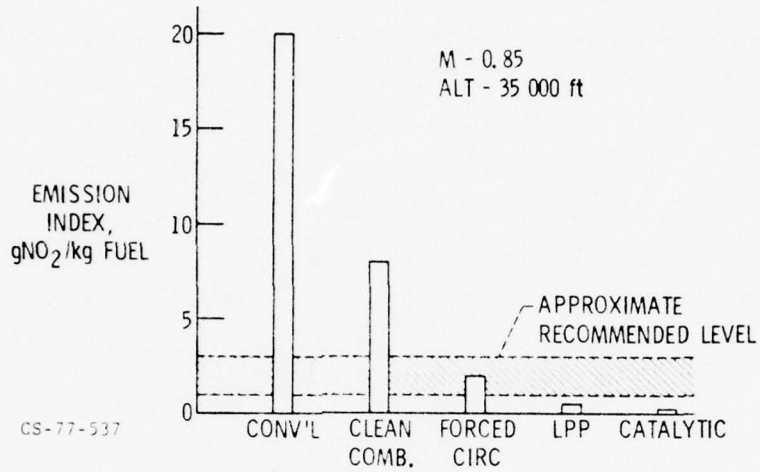

### SUPERSONIC CRUISE NO<sub>x</sub> EMISSION OUTLOOK

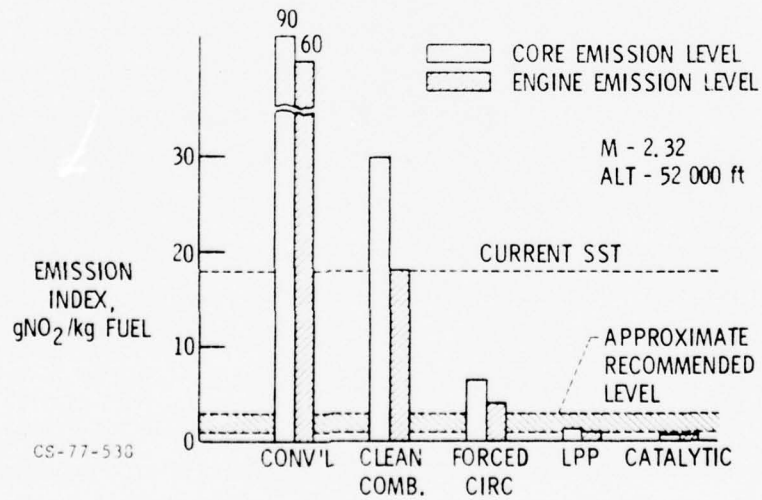

FIGURE 2-4. NO<sub>x</sub> emission outlooks according to Diehl et al., 1977

and effects of engine transients (relight requirements, compressor stall, etc.). All these problems (and the SCERP program) are in a relatively early state of development. Nevertheless, some interesting results have been achieved. Thus (Fig. 2-5), very low  $\text{NO}_x$  emissions can be achieved, such as 0.3 gm  $\text{NO}_2$ /kg fuel at the inlet conditions shown, at an equivalence ratio of 0.4 (which is uncomfortably close to blowout) with greater than 99 percent combustion efficiency. It is also of interest that pressure has little theoretical effect on  $\text{NO}_x$  formation at lean conditions, as shown in Fig. 2-6, in contrast to the usual 0.5 or 0.6 power dependency found with conventional combustors. The fragmentary experimental data are not very illuminating.

The operating margin question and fuel air preparation problem are illustrated by Figs. 2-7 and 2-8. Note that higher inlet air temperatures increase the operating margin; also note, however (Fig. 2-8) that the probability of preignition also increases. A number of other problems are also discussed and illustrated by Diehl et al.

Forced circulation techniques are discussed by Roberts and Butze (1977) in the same document. These involve use of lean premixed and prevaporized fuel-air mixtures with a recirculation zone for flame stabilization. Studies on these concepts were begun in March 1974 and were in the final stages at the time of the Aircraft Engine Emissions Conference (May 1977). The two concepts studied were jet-induced circulation (JIC) and vortex air blast (VAB); these are illustrated in Fig. 2-9. The goals, in general, were low  $\text{NO}_x$  emissions (1.0 gm/kg) along with low CO (0.5 gm/kg) and total hydrocarbon (0.5 gm/kg) emission indices at a combustor inlet temperature and pressure of 1500°R and 5 atmospheres, with a combustor outlet temperature of 3200°R, using Jet A-1 fuel. The techniques are, in effect, specific mechanical approaches to carrying out the lean premixed

### FLAME TUBE EMISSIONS

5.5 atm, 980° F

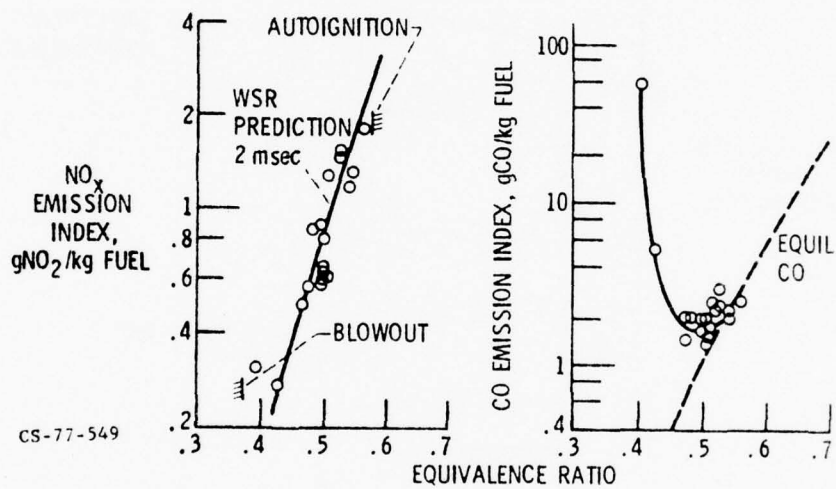

FIGURE 2-5. NO<sub>x</sub> and CO emission indices under lean conditions. The auto ignition and blowout limits are shown for the conditions indicates. "WSR" refers to a "well-stirred reactor" theoretical result.

Source: Diehl et al., 1977

### PRESSURE EFFECT ON NO<sub>x</sub> EMISSIONS FOR JET A

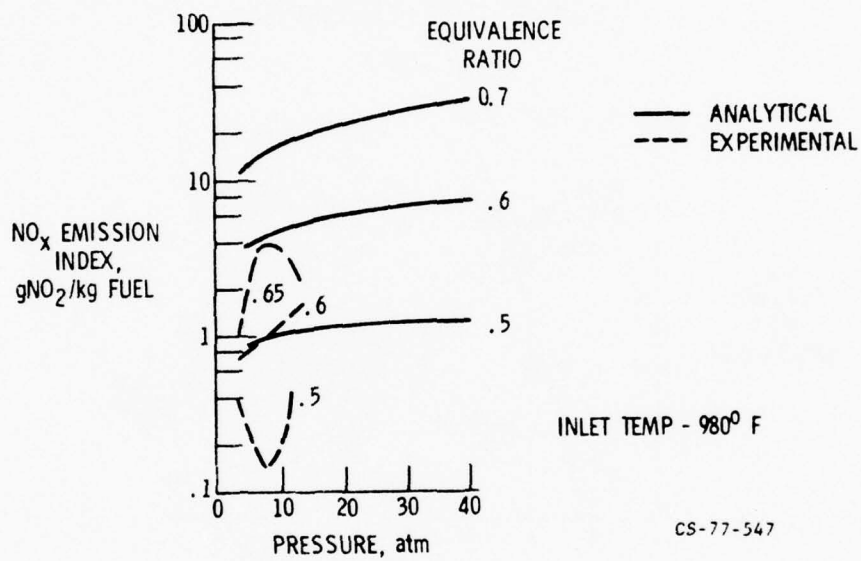

FIGURE 2-6. Theoretical and experimental pressure effects in NO<sub>x</sub> formation at various equivalence ratios as a function of pressure.

Source: Diehl et al., 1977

### PERFORATED PLATE STABILITY MARGIN

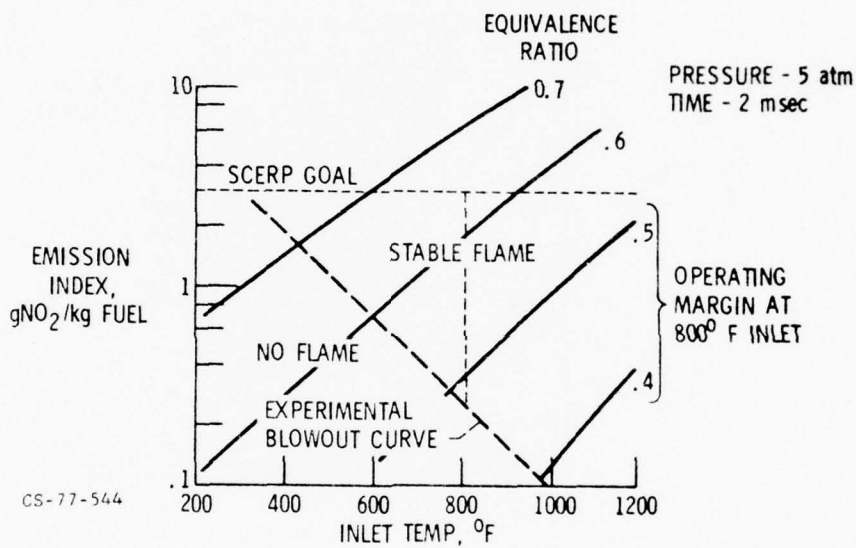

FIGURE 2-7.  $\text{NO}_x$  emission index at various equivalence ratios and inlet temperatures, showing stable flame, blowout, and operating margins.

Source: Diehl et al., 1977

JET A AUTOIGNITION DELAY AND  
DROPLET EVAPORATION TIMES

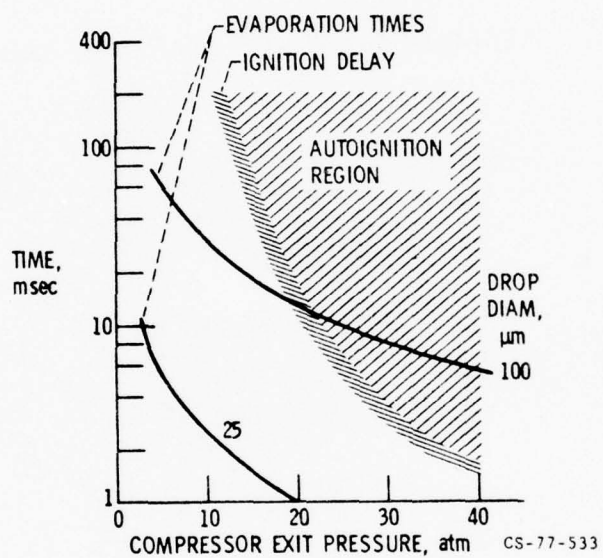
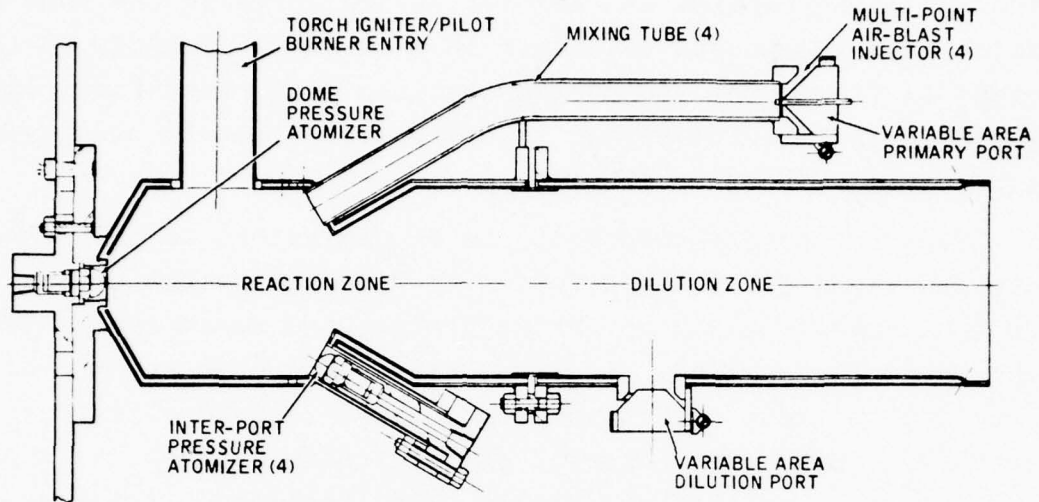

FIGURE 2-8. Auto ignition regions and droplet evaporating times as a function of combustor exit pressure and droplet diameter.

Source: Diehl et al., 1977

### JIC COMBUSTOR DETAILS



### VAB COMBUSTOR DETAILS

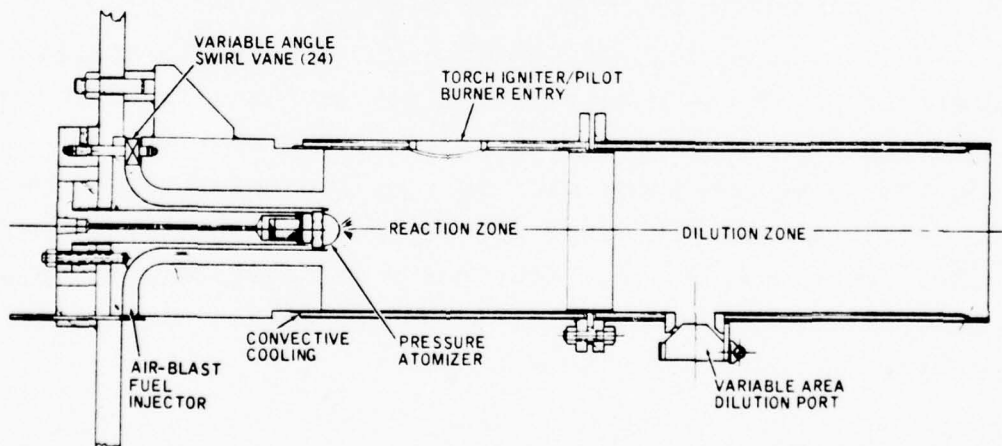

FIGURE 2-9. The jet-induced combustor (JIC) and vortex air blast (VAB) combustor concepts.

Source: Roberts and Butze, 1977



prevaporized combustion processes over a range of operating conditions (idle, takeoff, cruise). In the JIC system, the air and fuel are premixed and fed (at 30° relative to the combustor axis) into a combustion chamber in a direction counter to the eventual flow. The VAB system involves concurrent flow, with variable angle swirl vanes; reaction stabilization occurs in a resulting vortex recirculation.

Early efforts showed that low  $\text{NO}_x$  emissions at cruise conditions could be obtained, with the VAB concept the better one from an emissions standpoint at cruise, and essentially meeting the goal of 1.0 gm/kg. However, as was noted in earlier discussion, the lean stability deteriorated (and CO emissions increased) rapidly with decreasing inlet temperatures, as shown in Fig. 2-10, so that the simple, lean, premixed, constant-geometry combustor cannot be considered for use across the range of engine conditions.

More recent work with these concepts has been concerned with seeking ways to avoid the problems indicated above, using variable dilution, variable geometry, staging, etc.

The foregoing discussion has been intended to highlight briefly some of the possibilities and problems in achieving ultra-low  $\text{NO}_x$  combustors. It would appear obvious that considerable time and money will be required before such concepts can be brought to the level of safety and sophistication required for aircraft use. Stationary gas turbine systems or automotive applications using these approaches might well come before those for aircraft.

## 2.5 SOME COMMENTS

The foregoing discussion permits only a few general observations. Thus, uncertainties in emission indices still exist as they have since 1973. Aircraft fleet projections, particularly of SSTs, have dropped dramatically. Progress is being

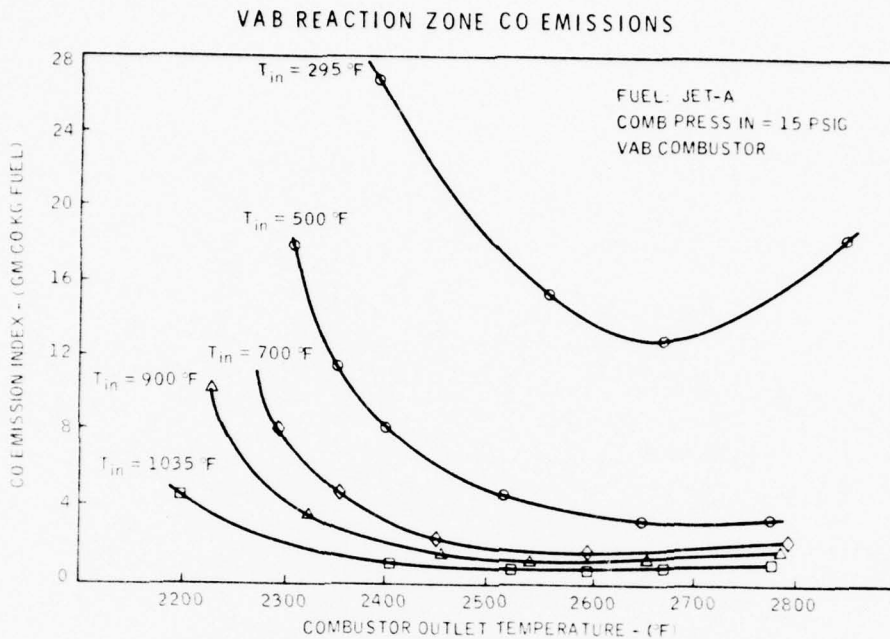

FIGURE 2-10. CO emissions with a vortex air blast (VAB) combustor simulated idle pressure with various inlet temperatures, illustrating rapid rise in CO at low inlet temperatures.

Source: Roberts and Butze, 1977

made on  $NO_x$  cruise emission reduction programs (although the original basis for these efforts, as will be described more fully in the following sections) has been shown to be in substantial doubt) but the attendant problems in achieving large reductions in  $NO_x$  emission index values are all too evident.

### 3. OZONE MODELING DEVELOPMENTS

#### 3.1 INTRODUCTION

As noted in Section 1.0, the cut-off date for input to our previous summary report under the HAPP effort (Oliver et al., 1977) was December 1976. Since that time, there have been a number of developments affecting the computed effects on ozone of aircraft emissions, chiefly in the kinetics area. The principal effort, in a national sense, in this period has been devoted to the halogen problem; the fertilizer question has also been subjected to some study. The sheer volume of this other work, and its somewhat peripheral relevance to the aircraft question, preclude its detailed review here. An attempt will be made to draw from these work developments which seem to be of particular interest to aircraft effects and to the uncertainties therein.

As will be evident in the following material, changes in chemistry which have generally reduced computed effects of  $\text{NO}_x$  additions have brought what have been secondary issues to the fore, such as the effects of thermal feedback, of simultaneous water-vapor injection, and of detailed choices in reaction rates; the sign of the effect on the ozone column change can vary with choices in these matters, as well as with other modeling details. A recently passed law is of interest in this connection and merits comment.

#### 3.2 SOME COMMENTS ON PL95-95

In connection with modeling "details," the apparent impact of Public Law 95-95, passed on August 7, 1977, should be noted.

This act, *Clean Air Act Amendments of 1977*, covers many aspects of air quality; however, amendments to Section 126 are of prime interest here. This amendment adds a Section B to this section of prior legislation entitled "Ozone Protection;" the amendment refers only to ozone in the "stratosphere". The stratosphere by definition (Sec. 152) is "that part of the atmosphere above the tropopause," and thus includes the mesosphere, etc. The act states that the "Administrator [of the EPA] shall conduct a study of the cumulative effect of all substances, practices, processes, and activities which may affect the stratosphere, especially ozone in the stratosphere" and goes on to cite halocarbons, other sources of chlorine, bromine compounds, and emissions from aircraft. EPA thus becomes the lead agency for protection of stratospheric ozone, and through a Coordinating Committee, reviews and comments on research by, and research plans of, other agencies. An interim report by the NAS has, in fact, already been prepared under this act (NAS, 1977).

While the full implications of this act are still developing, an apparent (if perhaps temporary) result has transpired due to emphasis in the act on changes in *stratospheric* ozone, rather than on changes in the ozone column, including changes in the upper troposphere, which total effect, of course, controls changes at the earth's surface. This emphasis can lead to awkward reporting problems for investigators. Thus, in connection with climatic effects, release of halocarbons may cause depletion of ozone in the stratosphere, which would involve a cooling at the earth's surface; however, on inclusion of the tropospheric greenhouse effect of the halocarbons themselves, the net effect appears to be a surface warming. Similarly, 1-D atmospheric ozone modelers, if the act is taken literally, may decide not to include the troposphere in their models, and may obtain thereby misleading results,\* particularly if aircraft effects

---

\* It should be noted that modelers who exclude the troposphere have argued the opposite; that is, tropospheric chemistry, in their view, is so poorly understood that inclusion of the troposphere can lead to misleading results.

are being computed. With aircraft (see e.g., Hidalgo and Crutzen, 1977), particularly realistic fleets with principal traffic in the upper troposphere, significant changes can take place which may be more important at ground level than the very small change (possibly of the opposite sign) which may result in the stratosphere. Any model excluding the troposphere necessarily fixes conditions more or less arbitrarily at the lower model boundary (the tropopause), thereby affecting or suppressing the changes which would take place at this altitude in a model with a troposphere included. Erroneous or misleading estimates of ozone effects, like those for climate, could result using such procedures.

### 3.3 TRANSPORT PROCESSES: 1-D PARAMETERIZATION

#### 3.3.1 Background

The fundamental problems in representing atmospheric transport processes or "dynamics" in a one-dimensional parameterization (the " $K_z$ " profile) have been described at length elsewhere (see, e.g., Mahlman, 1975; COMESA, 1975; NAS, 1976, Appendix B; Oliver et al., 1977). Here we note only that (1) in principle, each tracer has its own profile, depending on its sources and sinks; water vapor, e.g., very likely behaves differently than does either  $\text{NO}_x$  or ozone; (2) fundamental ambiguities as to interpretation of 1-D results are evident, with some modelers arguing that their models represent "global (time and space) averages" and others, mean mid-latitude conditions, etc.; and (3) for sources near the tropopause, no satisfactory means of taking into account time and latitude-varying tropopause heights, or regions of upwelling or subsidence, has been developed. In spite of these and other problems, however, the great computational simplicity introduced by carrying out computations in one-dimension has insured their continued use. Attempts to refine such representations are of continuing interest, as are

intercomparisons of the estimates used by different authors. Some recent developments, with relevant background information follow.

### 3.3.2 N<sub>2</sub>O Tracer Studies and Derived K<sub>z</sub> Profiles

Undoubtedly, the most extensive recent work in characterizing 1-D transport is that of Schmeltekopf et al. (1977, 1977a). These authors reported on an extensive series of measurements of N<sub>2</sub>O as a function of altitude (to about 35 km), latitude (78°S to 63°N) and (to some degree) season, with interpretation thereafter as to K<sub>z</sub> profiles. The work is apparently not yet fully reported; the following is principally from Schmeltekopf et al. (1977).

Schmeltekopf et al. (1977), argue that, while both CH<sub>4</sub> and N<sub>2</sub>O are suitable tracers, the loss processes involved have greater uncertainties with CH<sub>4</sub>, so that N<sub>2</sub>O is a more suitable tracer. Thus, CH<sub>4</sub> is destroyed principally by OH, the profile of which is not well established, as well as by O(<sup>1</sup>D) (and by Cl, although not noted by Schmeltekopf), whereas the principal loss process (~ 80 percent) for N<sub>2</sub>O is photolysis

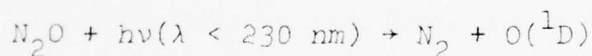

with secondary destruction mechanisms (~ 20 percent from O(<sup>1</sup>D) formed by photolysis of O<sub>3</sub>, giving



or



Schmeltekopf et al. (1977) state that the overall uncertainty in the photodissociation rate is ± 50 percent. (This is evidently less than the overall uncertainty in [OH] concentration, on which only limited data exist--see Anderson, 1976).

Several aspects of this work are of particular interest:

1. Local  $K_z$  profiles vary tremendously with latitude, with, e.g., Alaska values being up to two orders of magnitude smaller than Panama values. In the authors' words, "Individual  $K_z$  profiles probably have little physical reality."
2. Inclusion of a Panama profile, of which only one was available at the time of the 1977 paper, roughly tripled the global average eddy diffusivity otherwise obtained, in the 17-27 km altitude range principally discussed.
3. The area-averaged eddy diffusivity coefficients derived were found to be a factor of 1.5 to 3 times those found by Hunten (1975) using  $\text{CH}_4$  data taken at Palestine, Texas. This result relied heavily on the Panama data.

In this author's opinion, the  $K_z$  profiles derived by procedures, such as those used by Schmeltekopf et al., seem most appropriate to a material, such as  $\text{N}_2\text{O}$  or one of the long-lived halocarbons, which involve a surface source, with long life and good mixing in the troposphere, and a stratospheric sink. To what extent the mean  $K_z$  profiles so derived are applicable to stratospheric sources, concentrated in terms of latitude, and with tropospheric sinks, is a matter of some debate.

The procedures used by Schmeltekopf et al. (1977) give  $K_z$  profile data for roughly the 17-27 km region, and as such are not alone sufficient for use in 1-D modeling. However, Crutzen et al. (1978), from the same group, in a study of chlorocarbon effects on ozone, utilized these and other data to form a  $K_z$ -altitude profile which they characterized as follows (in  $\text{cm}^2/\text{sec}$ ):

$$\begin{array}{ll}
K_z = 7 \times 10^4 & 0 \leq z \leq 8 \text{ km} \\
K_z = 4 \times 10^3 + (4 \times 10^3 - 7 \times 10^4)(z - 15)/ & 8 \leq z \leq 15 \text{ km} \\
K_z = 4 \times 10^3 \exp [(z - 15)/5.54] & 15 \leq z \leq 29 \text{ km} \\
K_z = 5 \times 10^4 & 29 \leq z \leq 50 \text{ km} \\
K_z = 5 \times 10^4 \exp [(z - 50)/10.9] & z > 50 \text{ km}
\end{array}$$

The values from 15 to 30 km are based on the N<sub>2</sub>O data. At higher altitudes, the values are based on methane data (Ehhalt et al., 1974), adjusted by a factor of 2 to account for day-night averaging. As noted earlier, the Schmelkopf 1977 K<sub>z</sub> values are considerably greater in the 15-25 km region than are the Hunten 1975 values.

This profile was included in comparison studies herein of effective K<sub>z</sub> values (see Section 3.3.6 below) and is also of general interest. For aircraft (and other) effects studies, in a later paper, using a 1-D steady state model, with a 10-km lower boundary, Crutzen and Howard (1978) used a modified K<sub>z</sub> profile, still based on the N<sub>2</sub>O data, as follows:

Above 15 km

$$K_z = 5 \times 10^3 \exp [(Z-15)/8], \text{ but } < 10^6$$

From 10-15 km, two profiles were used

$$K_z \text{ (high)} = 5 \times 10^3 \exp [(15-Z)/2]$$

$$K_z \text{ (low)} = 5 \times 10^3$$

with Z in km and K<sub>z</sub> in cm<sup>2</sup>/sec.

The statement is made that the K<sub>z</sub> (high) relationship is more appropriate to global conditions, representing a continuous transition from troposphere to stratosphere, whereas K<sub>z</sub> (low) is more appropriate at latitudes poleward of 40°. These relationships are sketched on Fig. 3-1, along with certain other profiles of interest.



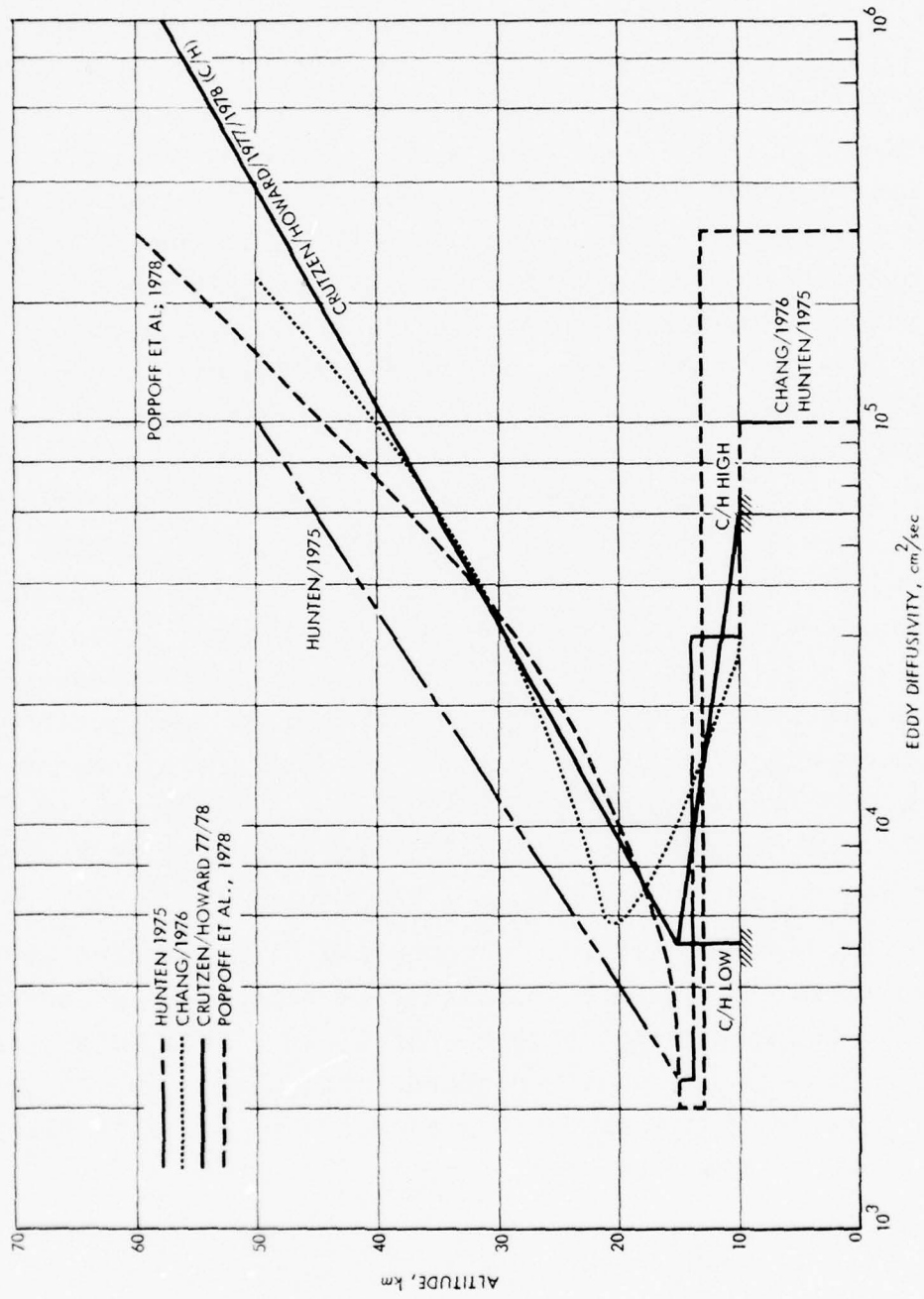

525/183

FIGURE 3-1. Some eddy diffusivity profiles of interest

### 3.3.3 The NASA-Ames Model $K_z$ Profile

Poppoff et al. (1978) and Turco and Whitten (1977) describe the NASA-Ames 1-D model. The  $K_z$  profile used by them (see Section 3.5.5) in a recent assessment and referred to as a "WT" or "Wofsy-type" profile is plotted as Poppoff et al., 1978, on Fig. 3-1. This profile includes a very low eddy diffusivity region near the model tropopause, followed by a rapid increase in  $K_z$  with altitude. The plot shows a  $K_z$  value for the troposphere taken from Turco and Whitten (1977); their recent modeling exercises, however, have not included the troposphere (Poppoff et al., 1978). The small eddy diffusivity values in the 13-15 km region lead to slow transport of material to the troposphere and large accumulations (long residence time, or burden/flux) from steady stratospheric sources. The profile in the region was developed to make the model consistent with transport of excess C-14, following Johnston et al (1976).\* The Hunten/1975 profile is also shown; it also was noted by Johnston et al. (1976) as leading to a reasonable representation of the excess C-14 data. There has, of course, been controversy surrounding the use of excess C-14 data in this manner. See Chang, 1975; Mahlman, 1975; Oliver et al., 1977 (pp. 3-85 to 3-89); also Mahlman and Moxim, 1978 as discussed in Section 3.3.5 below.

Turco and Whitten (1977), in agreement with Johnston et al. (1976) note that it would be difficult to reproduce excess C-14 data with a tropopause set higher than 13 km. This height is thus properly a global model tropopause which may not (in our opinion) have any physical reality relative to aircraft flight in, for example, mid-latitudes.

---

\*The WT  $K_z$  profile also leads to good agreement with the measured  $N_2O$  and CFM distributions (R.C. Whitten, private communication, 1978).

#### 3.3.4 Latitude-Tropopause Adjustments

In the above vein and as noted earlier, the proper treatment of aircraft altitudes relative to tropopause altitudes, and proper mean values thereof for various problems of interest, has not been given adequate attention. Hunten (1975) recommended a 2-km upward adjustment of aircraft altitudes for traffic at about 40°N, to compensate for tropopause differences between 40°N and about 30°N, for which his model  $K_z$  profile was developed. Mahlman (1975) pointed out some of the difficulties with simple approaches of this type. In NAS (1976) Appendix B, some alternative adjustment procedures were recommended for tropopause height variations; if adopted, these approaches would at least keep aircraft positions correctly above or below local tropopause heights. (See Oliver et al., 1977, pp. 3-94.) The procedures used by Crutzen and Howard (1978) were described earlier in Section 3.3.2. Poppoff et al. (1978) however, based on 1-D and 2-D modeling efforts, argue for direct use of the "WT" profile, with a 13-km tropopause, without aircraft altitude adjustment.

#### 3.3.5 Some Relevant Aspects of a 3-D Tracer Study

Mahlman and Moxim (1978) have carried out a model experiment which is relevant to the questions just discussed. In this experiment, using a 3-D global general circulation model, an instantaneous pulse of inert water-soluble tracer was injected on 1 January at 65 mbar (~ 18.8 km) with its center of 36°N and 180°E. The pulse was spread in such a way that most of this tracer was contained in a "single stratospheric disturbance." One aspect of their results is of particular interest, represented by Fig. 3-2. In this figure, time and zonally averaged mixing ratio profiles in October of the fourth model year are shown. While it is not possible from the plot alone to derive  $K_z$  profiles (a steady state distribution does not prevail), it is of interest to note the smoothness of the "global average"

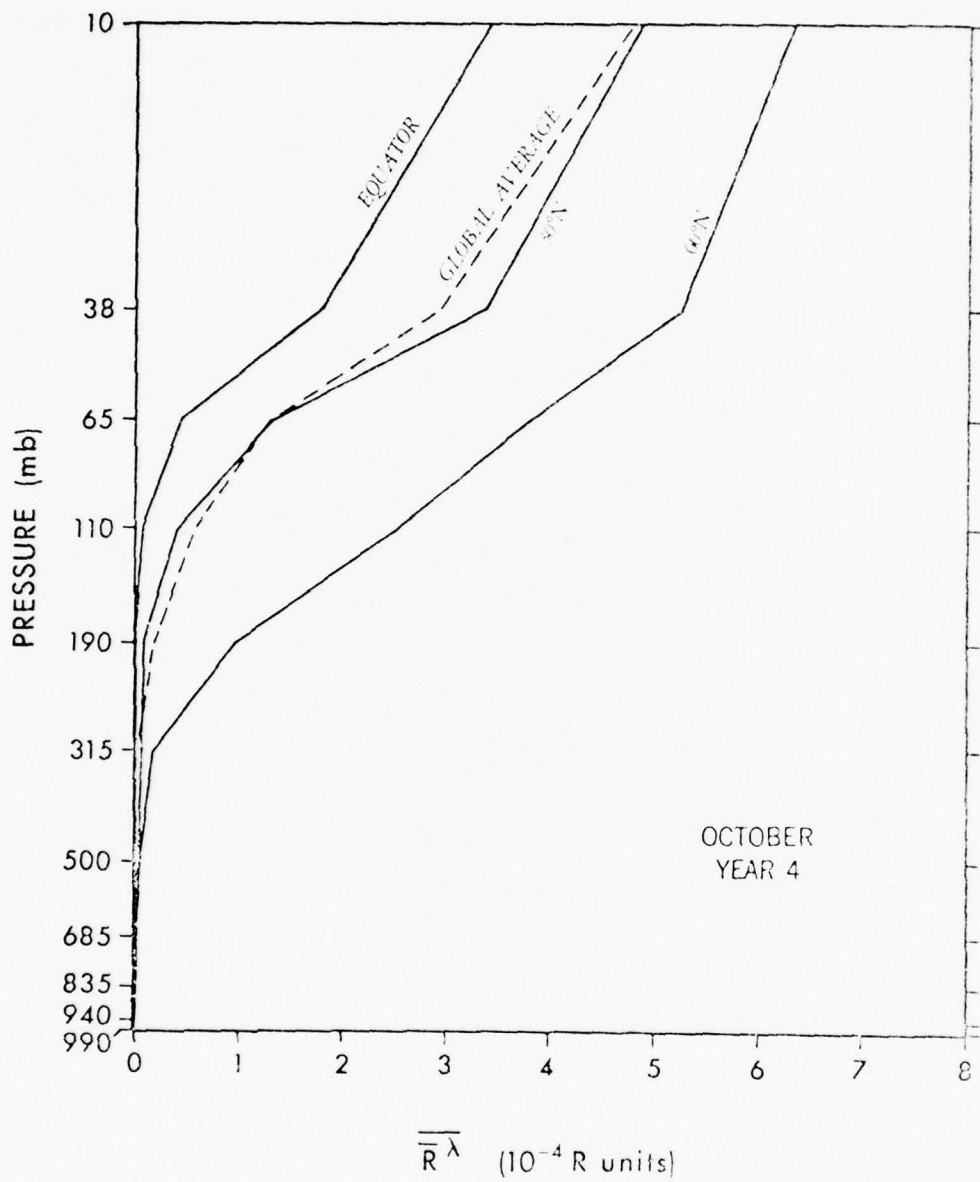

FIGURE 3-2. Tracer study results

Source: Mahlman and Moxim, 1978

curve up to 38 mbar relative to curves for other latitudes. In general, a break in the curve is caused by a change in the rapidity of vertical transport, which in 1-D modeling would be represented by an "eddy diffusivity."\* A decrease in slope is analogous to a decrease in eddy diffusivity. Qualitatively, these 3-D results (in our opinion at least) tend to support the use of  $K_z$  profiles with relatively smooth transition from tropospheric to stratospheric values, at least for "global average" 1-D models.

As a separate matter, Mahlman and Moxim (1978) note (referring to Mahlman, 1975, for more detail) that feedback of C-14 from the troposphere to the stratosphere would affect apparent removal rates of excess C-14 during the second year following cessation of testing. Thus, the relevance of excess C-14 at longer times as a tracer is brought into question (excluding other considerations); however, Mahlman and Moxim (1978) also find that the water-soluble gaseous tracer is removed somewhat more slowly than were particulates from weapons tests, indicating that sedimentation does play an important role over longer times (perhaps more than one year).

### 3.3.6 Studies Using Zr-95 Data

In a previous report, Oliver et al., 1977 (Appendix C) work by Bauer, Oliver, and Wasylkiwskyj was reported in which the behavior of Zr-95 injected by Chinese nuclear tests (40°N, 90°E, approximately 18 km altitude) was examined in a 1-D model as a function of time after several events at different seasons. This work has since been substantially revised (Bauer et al., 1978) and, for completeness, is included as Appendix B of this report.

---

\* 3-D models do not use eddy diffusivities, except in subgrid parameterizations in which very low values are used. In the particular experiment described, zero vertical subgrid eddy diffusivities were used.

The reason advanced by Bauer et al., 1978, for examination of the Chinese data is that these data more closely resemble a mid-latitude stratospheric aircraft source with a tropospheric sink than do any of the other data used, such as data on  $\text{CH}_4$  or  $\text{N}_2\text{O}$  which involve a globally-dispersed surface source and a stratospheric (primarily high-altitude tropical) sink. In Bauer's approach, the available data are treated in terms of a two-step model (a constant tropospheric  $K_z$  and a constant stratospheric  $K_z$ ) which is justified, at least for an initial investigation, on the basis of simplicity; i.e., a minimum in the number of variables is needed to describe the data involved. The appropriate  $K_z$  form for mid-latitude stratospheric sources is not well established in any event. A correction is included for sedimentation. Two mean tropopause values were considered (11 and 14 km) to determine the sensitivity of results to this variable. The data show that removal rates are much more rapid in the winter than in the summer, so that difficulty is encountered in attempting to develop an appropriate mean  $K_z$  for use in 1-D time- and space-averaged modeling. By making what were considered to be suitable assumptions, however, the authors were able to develop approximate mean stratospheric eddy diffusivities (tropopause to 18 km) and to calculate therefrom mean residence times and injection coefficients ( $\alpha$ ) in the manner of McElroy et al. (1974), or Hunten (1975 or 1975a). Results are shown in Table 3-1. Mean  $K_z$  values ( $\bar{K}$ ) found for the various tests are shown in the tabulation. The recommended values are those shown with an assumed 11-km tropopause.

The results in Table 3-1 suggest that residence times or injection coefficients for 18-km injections by either the Chang/1974 profile or the Chang/1976 profile are somewhat low, but that some of the other model values, particularly using the 2-km adjustment on the injection altitude recommended by Hunten (1975), are apparently high. As noted, a strong caveat is implied by the great seasonal variability found and the approxi-

TABLE 3-1. COMPARISON OF RESULTS FROM DIFFERENT MODELS FOR 18-km INJECTION\*

<u>Source</u>	$10^{-17} \alpha,$ <u>cm<sup>2</sup>-sec</u>	<u>t<sub>R</sub>,</u> <u>yr</u>
<u>This analysis (Two-Step Case)</u>		
<u>11-km tropopause</u>		
with sedimentation ( $\bar{K} = 7.25 \times 10^3 \text{ cm}^2/\text{sec}$ )	2.4	2.0
without sedimentation ( $\bar{K} = 9.75 \times 10^3 \text{ cm}^2/\text{sec}$ )	1.8	1.5
<u>14-km tropopause</u>		
with sedimentation ( $\bar{K} = 2.44 \times 10^3 \text{ cm}^2/\text{sec}$ )	5.0	3.5
without sedimentation ( $\bar{K} = 4.55 \times 10^3 \text{ cm}^2/\text{sec}$ )	2.5	1.9
<u>Other K-Profiles*</u>		
Chang/1974	1.7	1.4
Chang/1976	1.8	1.6
Hunten/1975	4.6	3.6
Hunten/1974 (+2)(18 km, latitude adjusted to 20 km)	7.1	4.6
Crutzen/1974	1.8	1.7
Crutzen-Isaksen/1975	1.9	1.7
Wofsy/1975	3.2	2.6
Crutzen et al., 1978	2.3	2.0
Poppoff et al., 1978**	4.4	3.6
Crutzen and Howard 1977/1978		
High	2.4	2.1
Low	3.3	3.2

\* See Appendix B (or Bauer et al., 1978) for details.

\*\* A  $K_z$  of  $7 \times 10^4$  in the 0-10 km region was assigned for these calculations. The troposphere is not included in the Poppoff et al., 1978 work.

mations needed to get annual means. It is suggested, however, that since the large Soviet tests in 1961-1962 took place in the late fall, overestimates of pollutant burdens may result if a year-round average  $K_z$  value is applied in computing effects.

Further analysis of these and other data using a more complex model ( $K_z$  increasing with altitude above the tropopause) is anticipated in follow-on work.

### 3.3.7 The Water Problem

a. Stratospheric Water. The original focus of potential SST effects on ozone was on effects due to added water vapor (see, e.g., H. Harrison, 1970; Hearings, 1971, p. 451 ff). A change of 0.2 ppm, as was suggested might result from an SST fleet, was estimated to cause a global average reduction in ozone of about 0.8 percent based on calculations by London and Park (Hearings, 1971). The reaction rates used were subsequently revised, with water vapor becoming of much less importance.\* The  $\text{NO}_x$  issue was raised in 1971 (Crutzen, 1971; Johnston, 1971) and became of dominant interest. Lately, however, with further revisions in reaction rates and with the  $\text{NO}_x$  problem becoming of lesser significance, the water problem has arisen again, as will be discussed more fully in a later section. This leads to the question of how water vapor should be handled in 1-D and 2-D models.

\* These early calculations were based on an assumed value for the rate of the  $\text{HO}_2 + \text{O}_3$  reaction of  $10^{-14} \text{ cm}^3 \text{ molec}^{-1} \text{ sec}^{-1}$ , as used by Hunt (1966) in modeling the ozone column using an  $\text{HO}_x - \text{O}_x$  atmosphere. It was later pointed out by Nicolet (1970) that the rate was probably much too high; modelers accepted his arguments and (initially) set the rate to zero in investigating the  $\text{NO}_x$  catalytic cycle and its effects on ozone (Crutzen, 1971, 1974). It is of interest that the early water vapor efforts, as well as later efforts involving  $\text{NO}_x$ , illustrate the fact that a model which reasonably duplicates a "natural" atmosphere may not correctly predict the effects of a perturbation to that atmosphere. Duplication of the "natural" atmosphere in a model is generally considered to be a necessary, but clearly not a sufficient condition, to predict effects of perturbations.



There are several related aspects to the water-vapor question. First, perhaps, is the limited data base in terms of reliable measurements at various times and places. (See Harries 1976, Pendorff 1977, Ellsaesser 1974.) According to Ellsaesser (1974), the data that do exist suggest that the conventional tropical tropopause cold-trap argument (Brewer, 1949) is quantitatively unsatisfactory in explaining stratospheric water vapor; a sink, specific for H<sub>2</sub>O vapor, is needed, which Ellsaesser suggested may exist in the Antarctic night. More data will be required (temperatures, upwelling velocities, relative humidities) to fully test these suggestions. It seems possible that the apparent problem may, in fact, be an artifact of averaging processes.\* The vapor pressure of water (ice) varies by a factor of about 2 with a 4°C change in temperature near -80°C, and regions in the tropics exist (as pointed out by Ellsaesser, citing Angell and Korshover 1974) wherein 12-month running mean temperatures are -84.5°C to -81.5°C, significantly colder than the -80°C nominal tropical tropopause used by Ellsaesser in his analysis. It may be precisely these cold regions through which air is entering the stratosphere. Similarly, tropospheric air enters the stratosphere on the anticyclonic side of jet streams in mid-latitudes; in these regions, temperatures considerably below zonal mean values are not uncommon (J.D. Mahlman, NOAA GFDL, private communication, 1978). These zonal inhomogeneities can be (and are) modeled in existing 3-D models (as at GFDL), resulting in a satisfactorily dry stratosphere.\*\* (A CH<sub>4</sub> contribution is not included in the GFDL model.) None of this, of course, proves

---

\* I am indebted to Dr. J.D. Mahlman of NOAA/GFDL for pointing out this and other "3-D" features of the water vapor question.

\*\* It is of interest that the GFDL model referred to has an excessively cold polar night, resulting in an excessive estimate of the Antarctic sink proposed by Ellsaesser. Even so, the resulting "sink" is of almost no significance. (J.D. Mahlman, private communication, 1978.)

that the models duplicate the real atmosphere, as the data against which to test the models is inadequate.

The above discussion suggests that water vapor transport into (and out of) the stratosphere is dependent on processes which can be represented in 3-D modeling, but which lead to difficulties in 1-D or 2-D models. In these simpler models, the cold-trap concept cannot be applied if mean temperatures are employed; rather, some further prescription is necessary. This is conventionally done in 1-D models by specifying a water vapor content above (or at) some model tropopause, and in somewhat more complex ways in 2-D models. It is not overly difficult to develop some prescription in these models which leads to a reasonable "natural" stratosphere, but it is difficult to establish that this prescription will permit an estimate of the perturbations to be expected from a stratospheric water source. This is certainly true if thermal feedback effects of water vapor, or effects on the tropical tropopause temperature (with changes in water vapor) are in question.

b. Water Vapor in the Upper Troposphere--Implications.

That the stratosphere is dry (very low relative humidity, except, presumably, near the tropical tropopause) in certain regions is well established.\* There seems to have been less attention given to upper tropospheric water contents in mid-latitudes, but the information that is available may have some implications for 1-D and 2-D modeling problems. Thus, data exist which show that upper tropospheric air, in general, apparently being mixed with dry stratospheric air (see Danielsen and Louis, 1977), is also

\* Manabe and Wetherald (1967), after reviewing rather limited data, modeled relative humidity  $h$  as a function of  $Q$  ( $\equiv$  ambient pressure/surface pressure) according to  $h = h^* \frac{Q-0.02}{1-0.02}$ , where  $h^* = 0.77$ , with adjustment to prevent the mass mixing ratio from dropping below 3 ppm. Manabe and Wetherald (1975) show model (2-D) relative humidity values (zonal means) of 40-50 percent in large areas, including the tropical tropopause, which figures presumably reflect the averaging processes described in Section 3.3.7a above.

fairly dry (i.e., low relative humidity).\* The Amarillo data plotted on Fig. 3.3 at about 30°N, show a relative humidity of about 19 percent at the tropopause.\* It is of interest also that the Amarillo data, as well as data at Washington, D.C., and Trinidad (CIAP Monograph 1, p. 3-52) show a gradual change in mixing ratio across the tropopause; however, other data (same reference) over Greenland show abrupt increases below about 250 mbar (which might represent the tropopause).\*\* With some exceptions, as in the cold regions near jet streams referred to earlier, and data such as that for Greenland, the air near the tropopause in mid-latitudes is not saturated. The existence, on average, of rather dry upper tropospheric air suggests that vertical mixing from below in this region is not (on the average) extremely rapid, as implied by models using large values of tropospheric eddy diffusivity: further, the lack of gradient across the tropopause suggests that extreme step changes in eddy diffusivity at the tropopause are not representative of the actual atmosphere. There is some additional support for this lack of step change in the data on HTO distributions with altitude across the tropopause (see Mason and Ostlund, 1976) wherein abrupt changes in concentration or in gradient were not found in crossing the tropopause.†

c. Water Vapor - General. The somewhat murky picture (in a quantitative sense) of water vapor transport in the upper

---

\* Saturation mixing ratios in Fig. 3-3 have been computed from the 1966 U.S. Standard Atmosphere and from the Smithsonian Meteorological Tables (List, 1958).

\*\* The data of McClatchey et al. (1972) as plotted by Ramanathan (1977) also indicate low relative humidities in the upper troposphere in the Arctic (winter and summer), mid-latitudes (winter and summer), and the tropics (~ 15 percent at 10 km). The plotted data appear to be suspect, however, in the stratosphere (~ 0.6 ppm).

† It is of interest that Poppoff et al. (1978) view this same data in a directly opposite way. We plan to examine these data more carefully in future work.

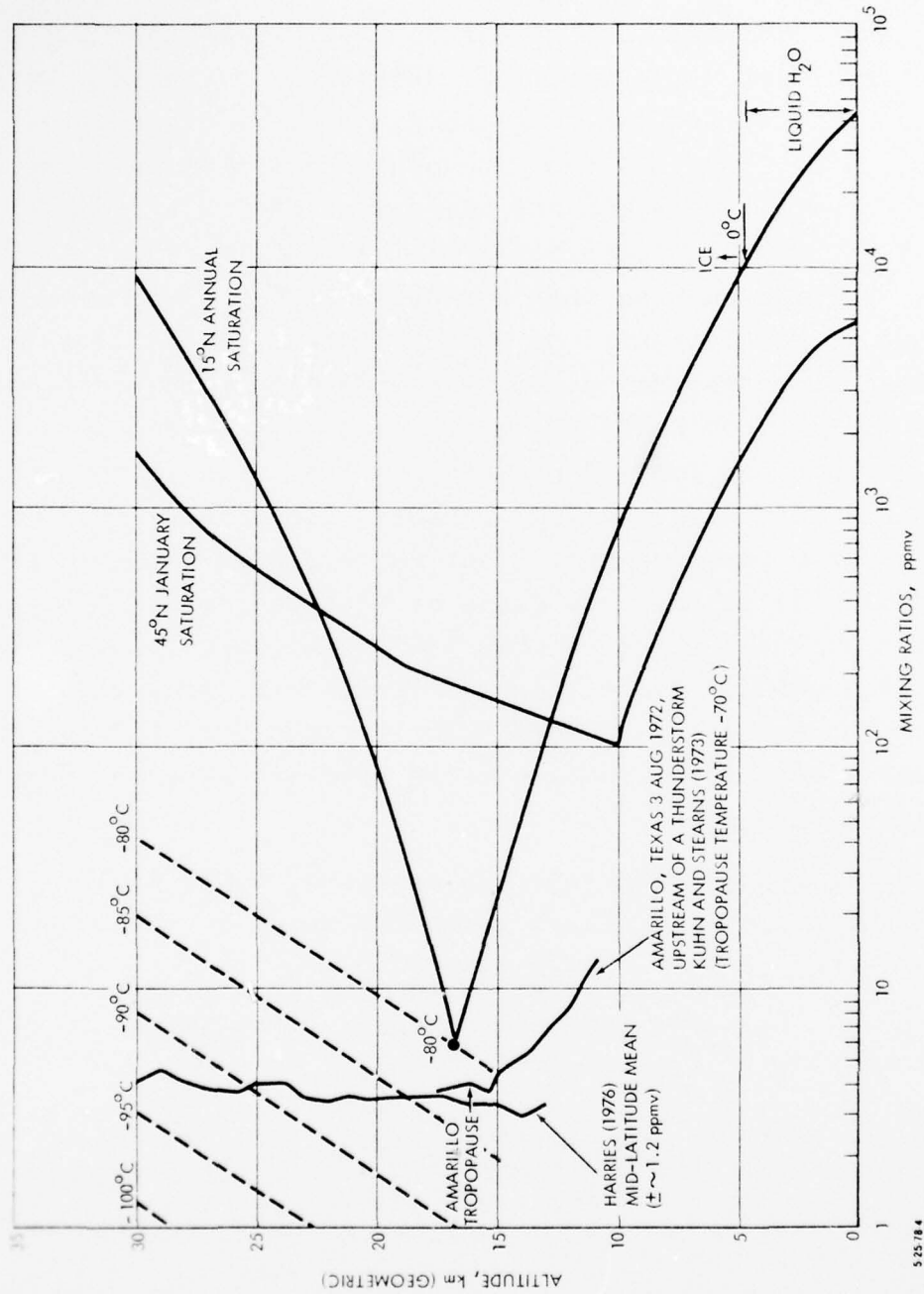

525784

FIGURE 3-3. Water vapor mixing ratios

troposphere and stratosphere is (following Danielsen and Louis, 1977, who do not discuss water but do discuss transport) that the principal source of stratospheric air is from upwelling in certain regions of the tropics with little vertical transport elsewhere and general subsidence poleward. The air carried into the stratosphere carries with it a small amount of moisture, which, in general, is then transported by bulk flow through the so-called tropopause gaps into the troposphere, where it is further mixed longitudinally and meridionally. Some air obviously also is carried into the stratosphere by eddy motion from mid-latitudes, as evidenced by regions of relatively high water vapor mixing ratios (6 ppm or 10 ppmv) found on a N-S traverse (80°N to 50°S at 17-19 km) by Hilsenrath et al. (1977). Antarctic sinks may exist (Ellsaesser, 1974; Stanford, 1977; Kuhn, 1977), as may Arctic sinks, but these may be unimportant in terms of the water budget and transport. It would seem that water vapor introduced above the tropopause in mid-latitudes has an uncertain fate; some meridional transport parallel to the sloping tropopause would certainly occur. Because of the general subsidence, vertical transport would be suppressed but not eliminated.

For reasons such as these, and because H<sub>2</sub>O was not of apparent consequence, CIAP modelers generally made no attempt to include water vapor injections (COMESA modelers did). It is of interest that the K<sub>z</sub> profile generated by COMESA for H<sub>2</sub>O vapor "behaves" better than that for NO<sub>x</sub> (see Fig. 3-4) which latter involves negative regions near 18 km. However, the COMESA model shows much too high a water content in the stratosphere (~ 50 ppm at 20 km in the Northern Hemisphere, decreasing with increasing altitude, and varying with season, to values of the order of 5 ppm at 33 km in the fall; see Fig. 4.423 COMESA, 1975), so that it is not clear to what extent the derived K<sub>z</sub> profile for H<sub>2</sub>O duplicates the "true" atmosphere "reduced" to one dimension.

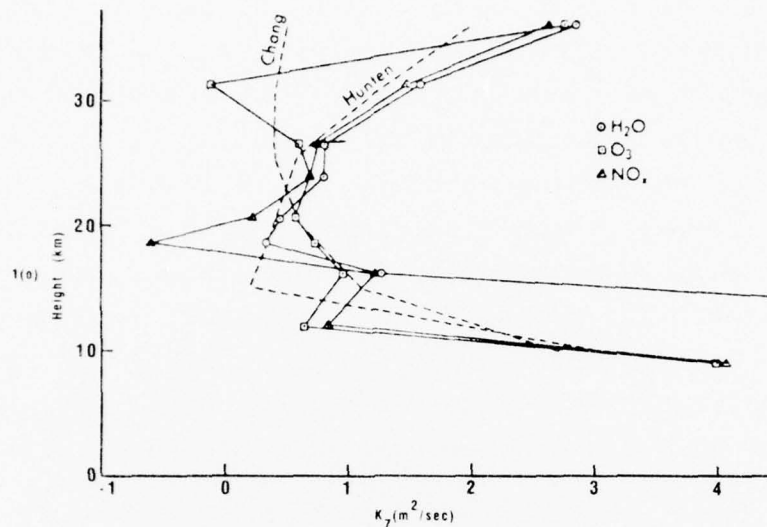

FIGURE 3-4. Globally averaged one-dimensional  $K_z$  profile based on water, ozone and  $\text{NO}_2$  fluxes and gradients; derived from 3-D results.

Source: COMESA 1975

In some cases in CIAP and in HAPP, estimates of the effects of water vapor have been made using adjusted water contents based on residence time or other arguments (as at Lawrence Livermore Laboratory; see Oliver, 1977); in other cases, rain-out coefficients (essentially fractional rates of decay at some model altitude) have been used. In still other cases, modelers have fixed the water content at some level (as NASA Ames,  $3 \times 10^{13} \text{ mol/cm}^3$  at 10 km; Turco and Whitten, 1977), and assumed the same  $K_z$  profile applies to water as to other species. "Rain-out coefficients" have also been applied in 2-D models over certain altitude and latitude bands in the troposphere (G. Widhopf, private communication, 1978).

Clearly, as water vapor effects on ozone and thermal feedback effects become of significance, more debate is called for on the "proper" way to model water vapor in reduced dimension models.

### 3.4 SOME IMPORTANT MEASUREMENTS OF TRACE SPECIES

A considerable number of field measurements of trace species has taken place or been reported in the period between this and our previous report. Two of these efforts seem particularly worthy of note in view of the questions raised by the measurements.

The first of these (the Cl and ClO measurements of Anderson et al., 1977, and Anderson, 1978) is of particular importance to the halocarbon problem, but is significant to the general understanding of ozone chemistry and, because background ClX content is important to the computations, to the specific question of the response of stratospheric ozone to perturbations by aircraft effluents. In brief, Anderson et al. (1977) have reported three sets of profile measurements of Cl and ClO taken 28 July 1976, 2 October 1976, and 8 December 1976 over Palestine, Texas, at altitudes from roughly 25 to 40 km. A 14 July 1977 flight (Anderson, oral presentation, Toronto, 1978) also took place. The Cl measurements involved no surprises: the ClO measurements, however, showed wide variability among the different flights--a factor of about 10. Furthermore, three of four profiles show a peak ClO content higher than called for by any of the models; the profile for 8 December 1976, in particular, showed ~ 8 ppb of ClO at 30 km, some three times the highest value predicted. As at least some of the ClX is necessarily in the form of HCl, the total ClX content of the stratospheric air implied by the flight was clearly far larger than can be accounted for by any known sources of chlorine. These results have not yet been explained; a discussion is included in Hudson, 1977. The July 1977 flight also showed excessive chlorine (~ 7 ppbv). It is of interest that in this flight, the OH and O<sub>3</sub> contents looked normal (Anderson, oral presentation, Toronto, 1978); i.e., the excess chlorine, if present, was having no evident impact on ozone. Wofsy (1978), in a detailed review of

theory and experiment with regard to stratospheric trace gases, also notes an excess of ClO, and notes difficulties in reconciling OH, ClO, and O<sub>3</sub> observations in the upper stratosphere. He finds the theory to explain adequately the major features of latitude and seasonal distributions of NO<sub>x</sub> and HNO<sub>3</sub>. It should be noted that important rate-constant revisions have been made since these calculations were carried out, so that the results--as with much or all of the work in this field--may need reexamination.

As noted above, ClX content of the stratosphere affects ozone results for NO injections with increased chlorine, leading to reduced or more positive effects. This has been shown by computations at Lawrence Livermore Laboratory, with their results summarized in Oliver et al., 1977; no similar results with the latest chemistry are available.

A second measurement program relates to the NO<sub>x</sub> content of the troposphere. The measurements involved are those by Noxon (1978), who reports tropospheric NO<sub>2</sub> (no NO<sub>x</sub>) measurements, and who finds tropospheric NO<sub>x</sub> to be perhaps an order-of-magnitude smaller than thought previously. The results are important to OH content calculations and thus to CH<sub>4</sub>, OH, Cl, other hydrogenated halocarbons, and CO lifetimes, and thereby to stratospheric ozone content. Response of tropospheric ozone to injections of NO<sub>x</sub> from subsonics may also depend on the absolute level of NO<sub>x</sub> in the troposphere. It might be noted, however, that the approach which has not, in the publication at least, considered aerosols, has been criticized as giving erratic results by Kuznetsov and Nigmatullina (1977). The implications are further discussed by Hidalgo (1978), but no new modeling results on aircraft NO<sub>x</sub> injections into the troposphere are available.



### 3.5 CHEMISTRY CHANGES AND MODELING RESULTS

#### 3.5.1 Introduction

In the sections just preceding, certain developments have been noted on the parameterization of transport processes. These developments have not, in general, been fully "folded" into the modeling results, partly because ambiguities are involved, but also and primarily, because other developments--in chemistry--have occurred which have been of more immediate significance. These developments in chemistry have reduced net effects of NO<sub>x</sub> injection on the ozone column substantially while somewhat increasing H<sub>2</sub>O effects; whether the net effect on the ozone column is positive or negative depends on a number of modeling variables, included among which, however, is the parameterization used for transport. Transport processes are thus still of significance.

#### 3.5.2 Chemistry Changes and Uncertainties

a. Previously Identified Problem Reactions. In a pioneering study of uncertainties, Duewer et al. (1977 and 1977a) pointed out the importance of five key reactions in evaluating perturbations of stratospheric ozone by aircraft (in a chlorine-free atmosphere): These are, using their reaction numbers:

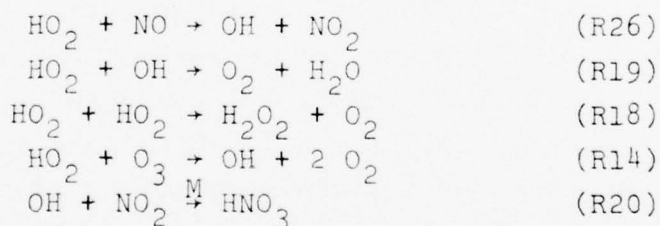

These reactions have since been reviewed by the same group (Duewer et al., in Luther, 1977). Recommended values for these (and numerous other reactions) have also been provided in Hudson (1977), along with discussion and estimated uncertainties. Crutzen and Howard (1978), and Poppoff et al. (1978) also discuss the various rate data for these and other reactions of significance.

The rate of reactions involving HO<sub>2</sub>, particularly at stratospheric temperatures and pressures, are, in general, still not fully established, although important progress has been made. Based on at least one example (see below) the uncertainties quoted, in our opinion, tend to be underestimated. In fact, the most important changes in computed aircraft effects since our previous report have resulted from the measurement at room temperature by Howard and Evenson (1977) of the rate of Reaction 26:



The rate found,  $(8.1 \pm 1.5) \times 10^{-12}$  cm<sup>3</sup>/sec at 296 K, has since been confirmed ( $\pm 0.1 \times 10^{-12}$ ) by four groups (Howard, 1978). This figure can be compared to the "survey" value quoted in CIAP Monograph 1 (p. 5-227) at 300 K of  $2 \times 10^{-13}$  cm<sup>3</sup>/sec (with an uncertainty factor quoted of 3 either way), a factor of 40 slower.

In very recent work (reported June 1978), Howard (1978) reports the following temperature-dependent rate for this reaction as

$$k_{26} = (3.3 \pm 0.7) \times 10^{-12} \exp [(254 \pm 50)/T]$$

over the range 230-400 K. This positive temperature dependence, and the rate measured, are in marked contrast to earlier values. Simonaitis and Heicklen (1977) reported, e.g., a rate constant at room temperature of  $1 \times 10^{-12}$  cm<sup>3</sup>/sec and a temperature dependence, based on certain assumptions as to other reactions of  $(-1400 \pm 500)/T$ . Hudson (1977) gives no temperature dependence, but gives an uncertainty at 230 K, corresponding to a multiplier of 1.4 to 0.35.

In studies prior to the Howard (1978) work, authors assumed temperature dependence as follows, with k values shown at room temperature and at a nominal stratospheric temperature:

Crutzen and Howard, 1978

$$k_{26(\text{HE})} = 3 \times 10^{-11} \exp(-390/T) \quad \begin{array}{cc} \underline{k_{296 \text{ K}}} & \underline{k_{230 \text{ K}}} \\ 8.0 \times 10^{-12} & 5.5 \times 10^{-12} \end{array}$$

Luther et al., 1977 (p. 47)

$$k_{26(\text{HE})} = 4.28 \times 10^{-11} \exp(-500/T) \quad \begin{array}{cc} 7.9 \times 10^{-12} & 4.9 \times 10^{-12} \end{array}$$

In later work at Lawrence Livermore Laboratory (LLL) (Wuebbles, 1978), the above temperature dependence for this reaction was dropped (See Section 3.5.4c.).

The central value expression for  $k_{26}$  developed by Howard (1978) yields  $9.96 \times 10^{-12}$  at 230 K. The much higher than heretofore measured rate for this reaction, its positive temperature coefficient, and the fact that measurements by the technique recently used by Howard (and others) require low pressures ( $< 10$  Torr, Burrows et al., 1978) have raised the possibility that a pressure-dependent three-body effect may be involved. Howard (1978) argues however, based on certain related data, that the measured rate as reported is applicable at atmospheric pressure.

This reaction, with this new rate, has a powerful influence on both tropospheric and stratospheric ozone chemistry in atmospheres containing  $\text{NO}_x$ , as shall be shown.

A second important reaction, which accounted for much of the change in computed  $\text{NO}_x$  effects on ozone between the period of the CIAP report (Grobecker et al., 1974) and our recent report (Oliver et al., 1977), is Reaction 19:

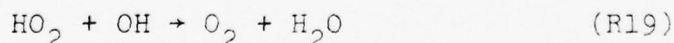

The CIAP figure of  $2 \times 10^{-10} \text{ cm}^3/\text{sec}$  was revised in the previous Duewer et al. evaluation (1977) to  $2 \times 10^{-11} \text{ cm}^3/\text{sec}$ ; the Hudson report recommends  $3 \times 10^{-11}$ . Burrows et al. (1977) reported a direct measurement of  $5.1 \times 10^{-11}$ , but this figure,

based on other evidence, is considered to be high both by LLL (Duewer et al., 1977; Luther, 1977) and by the NASA panel. (One might argue, in general, for the validity of direct measurements over indirect, in view of experience with the HO<sub>2</sub> + NO rate data.)

The reaction

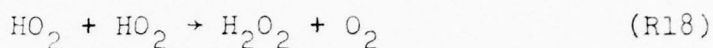

is also clearly of significance in view of the importance of HO<sub>2</sub>; e.g., in its reaction with NO. The importance of the reaction also depends on the rate of destruction of the H<sub>2</sub>O<sub>2</sub> formed, as discussed by Poppoff et al. (1978). Several room temperature measurements of the rate have been made (Luther, 1977), which appear to be in good agreement (at  $2.5 \times 10^{-12}$  with  $\pm \log k$  of 0.3; Hudson, 1977). However, there is concern (Hudson, 1977) in light of the Howard and Evenson (1977) measurement, that competing reactions may have been inadequately accounted for (Burrows et al., 1978). An argument is advanced by these authors for the formation of H<sub>2</sub>O<sub>4</sub> as an intermediate and extended to argue for possible pressure dependence in HO<sub>2</sub> + NO and ClO + NO reaction. No temperature dependence data exists for Reaction 18; the Luther (1977) report suggests a range of  $e^{\pm 1000/K}$  which alone represents a much larger uncertainty than indicated in Hudson (1977).

Crutzen and Howard (1978) in parametric studies used two values for this reaction:

$$k \text{ (standard)} = 5 \times 10^{-12} e^{-500/T} \quad (9.3 \times 10^{-13} \text{ at } 298 \text{ K})$$

$$k \text{ (high)} = 1.5 \times 10^{-11} e^{-500/T} \quad (2.8 \times 10^{-12} \text{ at } 298 \text{ K})$$

A fast rate constant for this reaction, according to Crutzen and Howard (1978) and Duewer et al. (1977), increases ozone depletion.

The rate of the reaction

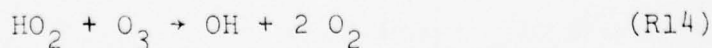

is also (still\*) quite significant to modeling of ozone in natural and perturbed atmospheres. A very recent (June 1978) expression has been reported by Zahniser and Howard (1978) as

$$k_{14} = (1.4 \pm 0.4) \times 10^{-14} \exp(-580 \pm 100)/T$$

over the range 250 - 370 K. At 230 K, the central value using this expression is  $1.1 \times 10^{-15}$  cm<sup>3</sup>/sec.

The rate expression used by LLL for Reaction 14 is  $10^{-13} \exp(-1250/T)$ , which yields  $4.4 \times 10^{-16}$  cm<sup>3</sup>/sec at 230 K. The rate quoted in Hudson, 1977 is, in cm<sup>3</sup>/sec,  $k_{14} = 7.3 \times 10^{-14} e^{-1275/T}$ , with  $\pm \log k$  equal to 0.3 (a factor of 2). The expression yields  $2.9 \times 10^{-16}$  at 230 K. Crutzen and Howard (1978) use two values, a "standard" and a "high" value as follows

$$\begin{aligned} \text{and } k \text{ standard} &= 10^{-13} \exp(-1525/T), \text{ or } 1.3 \times 10^{-16} \text{ at } 230 \text{ K} \\ k \text{ high} &= 2 \times 10^{-13} \exp(-1250/T), \text{ or } 8.7 \times 10^{-16} \text{ at } 230 \text{ K} \end{aligned}$$

The NASA (Hudson, 1977) rate is sensitive to the rate of HO<sub>2</sub> + HO<sub>2</sub>, which, as pointed out earlier, is uncertain, and may be influenced in turn by reevaluation of the impact of the HO<sub>2</sub> + NO reaction. Note that the new rate expression given, at 230 K, a value 3.8 times that given by the expression in Hudson (1977). The uncertainty quoted in Hudson (1977) corresponded to a factor of 2.

Crutzen and Howard (1978) [as well as Poppoff et al. (1978), also Duewer et al. (1977 and 1977a), Table 3.5, later herein] show that if the reaction, HO<sub>2</sub> + O<sub>3</sub>, is "fast," the "natural" ozone column is reduced, but NO<sub>x</sub> additions tend to enhance ozone. The effect is a subtle one, involving a *decrease* in a *reduction* (which thus becomes an enhancement); i.e., as explained by Crutzen (private communication, August 1977). If Cycle 1, for which the HO<sub>2</sub> + O<sub>3</sub> rate is controlling,

\* See first footnote Section 3.3.7a.

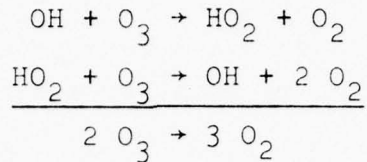

is rapid, then this ozone destruction cycle is significant. As NO is added, however, the cycle is slowed by the competitive reaction of HO<sub>2</sub> with NO as follows:

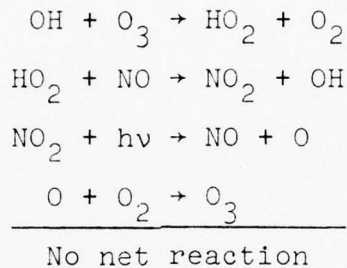

which decreases the destructiveness of the HO<sub>x</sub> cycle.

The fifth reaction listed by Duewer et al.--that forming HNO<sub>3</sub>--still involves a number of uncertainties but other reactions, as below, are of greater current interest.

Hudson (1977) cites two additional reactions in the HO<sub>x</sub> series which the NASA panel felt to be worthy of particular attention,

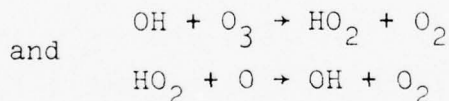

The uncertainties in these rates, in addition to the first four cited above, contribute significantly, according to Hudson (1977), to the overall uncertainty in stratospheric models.

b. Some Other Reactions and Species of New or Possibly Increased Significance. There has been considerable effort in the past few years devoted to stratospheric chemistry, which is particularly important to the halocarbon problem (see,

e.g., Hudson, 1977; Watson, 1977). As most of this work is of secondary interest to the aircraft problem, no attempt will be made to review it here. Rather, discussion will be limited to a few items which seem to be of interest.

$HO_2NO_2$  (*peroxynitric acid*).  $HO_2NO_2$  was not considered in modeling done under CIAP nor has it been included in most reaction schemes since. Attention to this species was apparently drawn by Simonaitis and Heicklen (1976) with subsequent attention being given it by Cox et al. (1977) and by Jesson et al. (1977).

The species is an analog of the well-known peroxyacetyl nitrate (PAN) important in smog chemistry. According to Cox et al. (1977),  $HO_2NO_2$  is not important in the troposphere, having a lifetime of only 9 seconds at 298 K. At stratospheric temperature (220 K), however, the lifetime is estimated at about one month (Jesson et al., 1977) to 0.3 years (Cox et al., 1977). It could thus be an important "reservoir" for both  $HO_2$  and  $NO_2$ , and could enter into a variety of possibly significant reactions (Jesson et al., 1977); its peak concentrations would be in the 20-30 km region, and could reach 1-3 ppb, largely at the expense of  $HNO_3$  concentrations (Jesson et al., 1977) without  $NO$  and  $NO_2$  concentrations being much affected.

Absorption data and photodissociation products are apparently inadequate. Modeling runs showing the possible effect of this species are not extensive; however, Poppoff et al., 1978, assuming  $HO_2NO_2$  to be photolyzed at the same rate as  $H_2O_2$ , found that its inclusion reduced ozone production by  $NO_x$ , but the absolute effect on the ozone column was small.

$HOCl$ . Jaffe and Langhoff (1978) have carried out a theoretical study of the ultraviolet photodissociation of  $HOCl$ . The results do not agree with earlier experiments which indicated a double-peaked absorption spectrum with peaks at about 220 and 320 nm; the theoretical results showed significant

absorption only at the shorter wave length. The significance of this is, of course, the HOCl is not photodissociated by the relatively strong flux in the 300-350 nm region, so that HOCl has a much longer life than previously believed for Cl species, reducing the effectiveness of the Cl catalysis cycle (see Prasad et al., 1978). Jaffee and Langhoff (1978) estimate HOCl life due to photodissociation (to Cl + OH) as 5.3 h at 40 km and 56 h at 30 km. They point out, however, that other processes as, e.g., reaction with O(<sup>3</sup>P) may predominate in controlling the lifetime.

HOCl could have some significance in the aircraft effects problem, thus such processes as

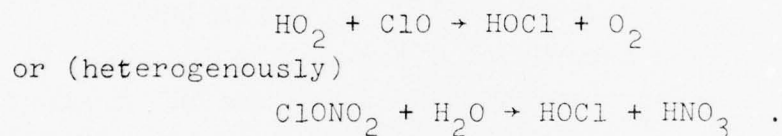

(These formation mechanisms were suggested by Jaffee and Langhoff, 1978).

*H<sub>2</sub>O<sub>2</sub>*. Poppoff et al. (1978) point out the fact that a "long" wave (> 255 nm) absorption tail for H<sub>2</sub>O<sub>2</sub> has been neglected in both CIAP and in Hudson (1977). This neglect produces an erroneously large estimate of H<sub>2</sub>O<sub>2</sub> in the lower stratosphere. In their model, CH<sub>4</sub>O<sub>2</sub> is assumed to behave like H<sub>2</sub>O<sub>2</sub>. Neglect of the long wavelength tail would put both of these species at fairly large values (~ 1 ppbv) which Poppoff et al. suggest would be incompatible with experimental data.

*The reaction ClO + OH → products.* This reaction, which, if it proceeds according to



at moderate rate, would be important in stratospheric chemistry, for two reactive species are destroyed (R.E. Roberts, IDA, private communication, 1977) in the process.



Classically, a reaction such as the one cited is assumed by kineticists to be a four-center reaction and too slow to be of consequence. In this case, however, the extreme energy release involved ( $\sim 55.6$  kcal/mol) and its possible chain-terminating character, suggest that it merits investigation. Its importance also relates to  $\text{CH}_4$  content; this reaction would be of greater importance with the recent  $\text{CH}_4$  profile measurements of Ackerman et al. (1977) than with earlier profiles (W.S. Smith, private communication, 1977).

The speculative reaction  $\text{O}_2 + \text{ClO} \rightarrow \text{O}_2\text{ClO}$ . Jesson (1978) in a speculative suggestion, commented that if the reaction

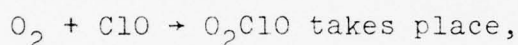

followed by

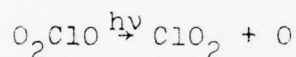

and

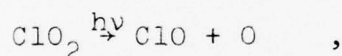

a mechanism for odd oxygen production would result, but no evidence is known for such a reaction.

### 3.5.3 Other Modeling Changes

Recent models have been improved in terms of their ability to incorporate such effects as multiple scattering, diurnal averaging, and thermal feedback. Each of these effects can be shown to be of significance; in 1-D modeling, however, the appropriateness of the various procedures, as in 1-D modeling in general, can be debated: each represents an improvement on an already "globally-averaged" process of sorts. The appropriate means of further averaging is never fully clear. In COMESA (1975) efforts, 1-D models were used with fully diurnally and seasonally varying sun, but with fixed eddy-diffusivity profile. Currently, modelers feel this process uses too much computer time, and may be difficult to justify; instead, in what seems to be a reasonable approach, the appropriate time-averaged

AD-A063 586

INSTITUTE FOR DEFENSE ANALYSES ARLINGTON VA  
RECENT DEVELOPMENTS IN THE ESTIMATION OF POTENTIAL EFFECTS OF H--ETC(U)  
OCT 78 R C OLIVER, E BAUER, W WASYLKIWSKYJ DOT-FA77WA-3965  
P-1343 FAA-AEE-78-24 NL

UNCLASSIFIED

2 OF 3  
AD A063586

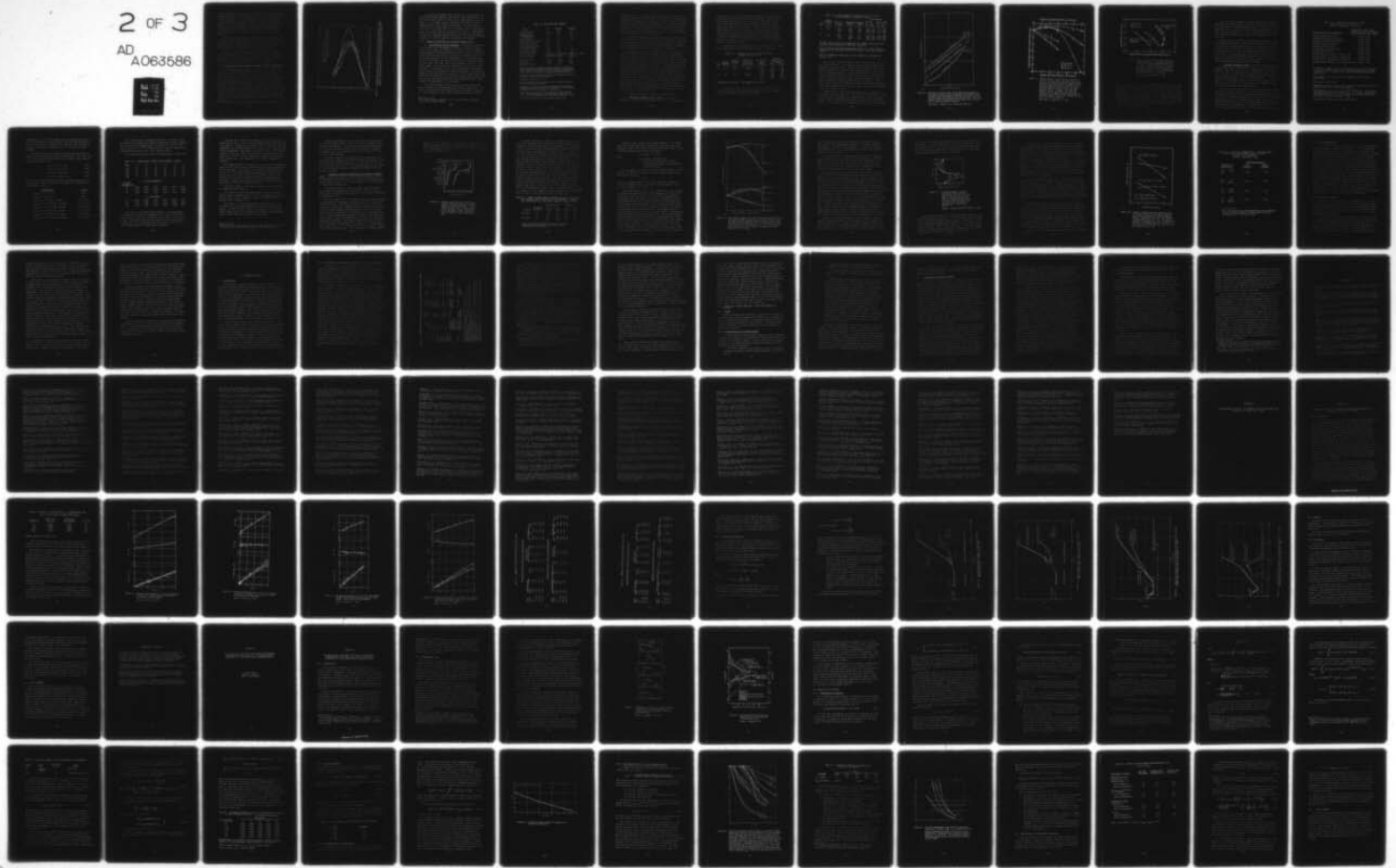

species product concentrations are determined by simpler diurnal averaging studies. The object, of course, is to avoid, in kinetic calculations, the multiplying together of concentrations of species which exist only at different times of the 24-hour period. As far as is known, however, all models "turn the sun on" and off over the entire model altitude simultaneously for all wavelengths in these diurnal averaging procedures, thus ignoring differences in sunrise and sunset with altitude and wavelength.

Thermal feedback effects also involve obvious questions as to whether the "average" heating or cooling processes are appropriately considered, or whether the heating processes, like the trace species in diurnal modeling, are in fact separated in time and/or space from the chemical reaction processes.

In spite of these questions, in this author's opinion, these "improvements" to the 1-D models are justified in indicating the potential importance of various physical phenomena, but higher (preferably 3-D) modeling will be necessary to provide a more quantitative indication of their significance.

#### 3.5.4 Effects of Recent Chemistry Changes on Model Atmospheres

Incorporation of the Howard and Evenson (1977) rate constant in existing models increases the ozone in the model "natural" atmosphere. The effect is evident in 1-D models, but rather easily dismissed since total ozone in a 1-D model varies significantly with  $K_z$  profile choice as well as with chemistry, and considerable ambiguity exists as to whether a 1-D model is a global average, a mid-latitude, or a hemispheric model. In a 2-D model, the effect becomes quite obvious, as shown in Fig. 3.5, provided by Widhopf (private communication, 1978). Note the large excess of ozone in the model atmosphere over that measured. This model had previously provided a more reasonable match between calculated and measured atmospheres.\* (See Widhopf et al., 1977).

\* Chlorine species are not included in these model results.

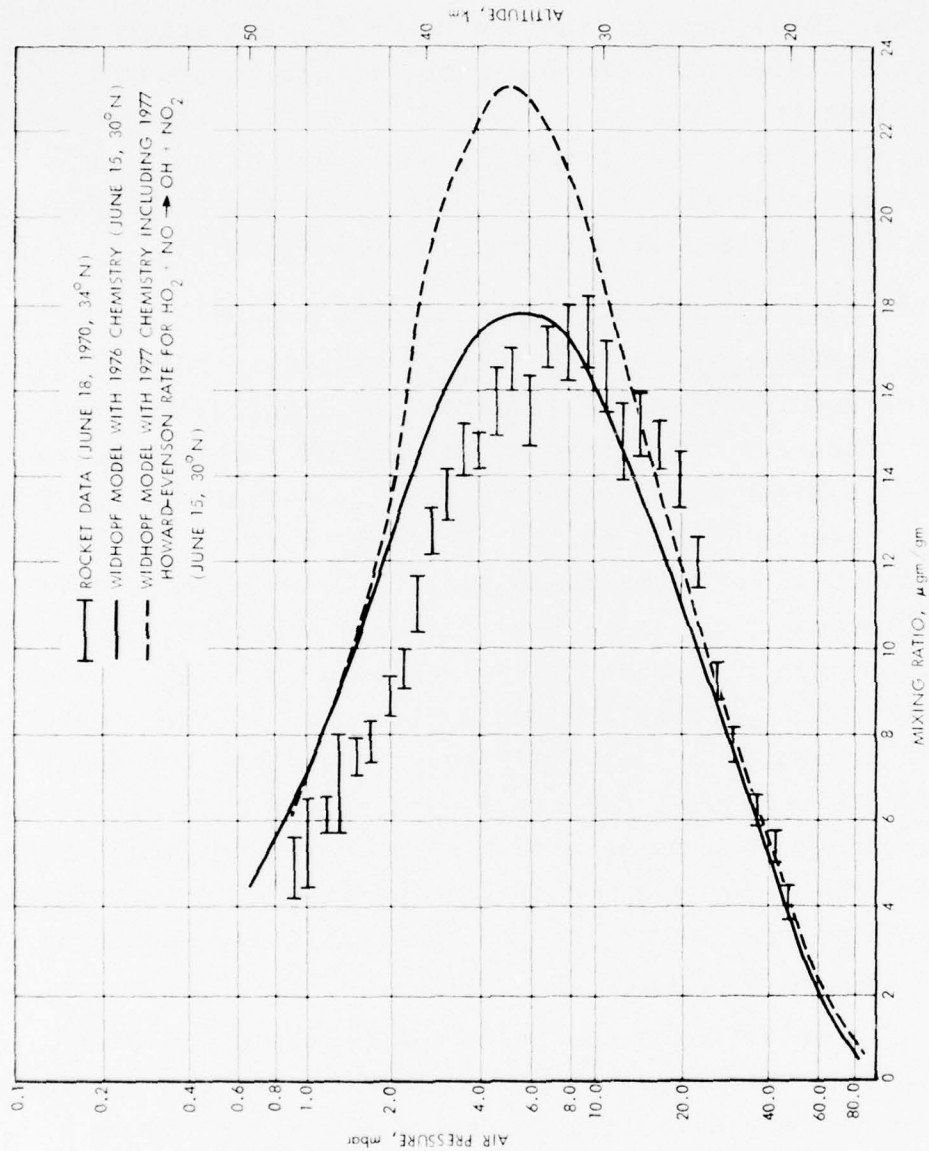

10 25 78 20

FIGURE 3-5. Widhopf model results showing how use of the Howard-Evenson Reaction rate distorts the model ozone profile relative to the measured atmosphere values. Widhopf, private communication, 1978. (See also Widhopf et al., 1977.)

It can be anticipated that the fast  $\text{HO}_2 + \text{O}_3$  reaction, as recently reported (Zahniser and Howard, 1978; Section 3.5.2), will reduce the excess of ozone, but to what extent is not yet known. In 1-D model results (Zahniser and Howard, private communication, 1978), use of the new  $\text{HO}_2 + \text{O}_3$  rate which is some four-fold faster than the old rate, at 230 K, brought the 1-D ozone column from 10.6 to 9.6 ( $\times 10^{18}$ ,  $\text{cm}^{-2}$ ). This approximate 10 percent reduction apparently would not be sufficient to bring the computed Widhopf model into line with the measured values, but would be expected to improve the situation.

### 3.5.5 Recent Calculations of Aircraft Effects (1-D)

a. The Different Models Compared. Potential SST effects on ozone have been reestimated in detail in light of recent (post-1976) changes in chemistry by workers at three organizations--Lawrence Livermore Laboratory (LLL), National Center for Atmospheric Research (NCAR) and the National Aeronautics and Space Administration at Ames (NASA-Ames). These studies have all used 1-D models, but these have varied in important details. No new studies have been done in the subsonic question. Only draft copies of the studies are available to us at the time of writing.\* A review as of July 1977 was prepared by Broderick (1978), which is scheduled for early publication. The paper by Broderick includes results as affected by the Howard and Evenson (1977) rate for the  $\text{HO}_2 + \text{NO}$  reaction; however, some effects not included in that paper have since become available, and these results are emphasized in the following.

The characteristics of the three 1-D models which seem most pertinent to this discussion are shown in Table 3-2. The models themselves are described in detail elsewhere (Chang et al., 1977; Poppoff et al., 1978, and Turco and Whitten, 1977;

---

\*The final version (Poppoff et al., 1978) became available during the review period.

TABLE 3-2. MODELS AND RUNS COMPARED<sup>1</sup>

Aspect	LLL	NASA-Ames	NCAR/NOAA
Troposphere Included	Yes	No <sup>2</sup>	No
Altitude Range, km	0-55	10-120	10-65
Steady State (SS) or Time-Dependent (TD)	TD	TD	SS
Vertical Resolution	1 km	2 km	1 km
Multiple Scattering Included	Yes	No	--
Albedo Effects Included	Yes	No	--
Diurnal Averaging Included	Yes	Yes	--
Thermal Feedback Included	Yes	No	--
ClX chemistry Included	Yes	Yes	Yes
Smog chemistry Included	Yes <sup>3</sup>	Yes	Yes
"Basic" $K_z$ profile(s) <sup>4</sup>	Chang/1976	WT; Chang/1976 <sup>5</sup>	Crutzen et al, 1978 <sup>6</sup>
Water Vapor Changes	Parameterized <sup>7</sup>	Computed	Computed
NO <sub>x</sub> injection rates	Varied	Varied	Fixed
NO <sub>x</sub> /H <sub>2</sub> O ratio	Varied	Varied	Fixed
H <sub>2</sub> O injection (alone)	Yes	Yes	No

<sup>1</sup>Refers to models in the configuration used to generate the main body of results discussed here. Each group has a number of models. The various effects listed as "included" can, of course, be excised if desired; similarly, effects shown as not included can, in general, be included if desired.

<sup>2</sup>NASA-Ames has a second model which includes the troposphere; they find that tropospheric ozone is little affected by SSTs.

<sup>3</sup>Simplified. See Oliver et al., 1977.

<sup>4</sup>By this is meant the implicitly preferred profile. Results are reported for various profiles by each group.

<sup>5</sup>"Wofsy-type," a profile similar to that of these authors but developed by NASA-Ames based on excess C-14 data. See Section 3.3.3. This is referred to elsewhere herein as the Poppoff et al., 1978 profile.

<sup>6</sup>Two versions are used to correct approximately for latitude (see Section 3.3.2). These are referred to as Crutzen and Howard (1978) "high" and "low." The mid-stratosphere portion is based on Schmeltekopf et al. (1977).

<sup>7</sup>Very recent calculations have included computed changes in H<sub>2</sub>O.

Crutzen, 1977). In a sense, the differences result from differences in approach and purpose. Thus, the LLL group has used and modified its model for a number of years to explore a wide variety of perturbations; SSTs, atmospheric nuclear explosions, and halocarbons have all been studied and sensitivities (particularly as to kinetics) explored. No claim (to our knowledge) has been made that an "upperbound" or other policy-oriented result is intended by these calculations.

The specific NASA-Ames modeling work described here is devoted entirely to the SST problem; in this work, the troposphere has little effect on the result as tested by them in studies with a second model which included the troposphere. They argue that tropospheric chemistry is uncertain in any event.

The NASA-Ames group also argues against the inclusion of thermal feedback effects for somewhat similar (uncertainty) reasons. The eddy diffusivity profile used by them is consistent with their approach. Crutzen and Howard (1978) also argue that tropospheric chemistry is poorly known and thereby justify its omission for studying SST effects. A major purpose of the Crutzen and Howard paper is to examine stratospheric ozone sensitivity to various reaction rates of current importance in stratospheric chemistry. In a sense, both the NASA Ames and Crutzen and Howard papers are consistent with the apparent intent of PL95-95 (see Section 3.2). Variations at and near the tropopause, which would be expected with aircraft cannot, in our opinion, be taken adequately into account with a model which fixes conditions (concentrations or fluxes) at the tropopause. None of the available modeling studies report effects of simultaneous injection of  $\text{SO}_2$ .

The various results will now be reviewed briefly.

b. NASA-Ames (Poppoff et al., 1978). Poppoff et al. emphasize effects on stratospheric ozone due to simultaneous

injections of  $\text{NO}_x$  and  $\text{H}_2\text{O}$  at various altitudes, and for "near-term" and "far-term"  $\text{NO}_x$  emissions technology. "Near-term" engine technology implies today's combustor technology; "far-term" technology includes two possible  $\text{NO}_x$  emissions levels, roughly 40 percent and 15 percent of today's values. The actual values used are quoted below. Their model, as indicated above, did not include a troposphere. Their results, which follow, are of particular interest in that they show clearly, for small to reasonable SST fleet sizes, the change in significance of  $\text{H}_2\text{O}$  and  $\text{NO}_x$  emissions due largely to the revision of the  $\text{HO}_2 + \text{NO}$  reaction rates.

Two aircraft types were considered by Poppoff et al., 1978, with varying  $\text{NO}_x$  emission indices, as shown in Table 3-3.

TABLE 3-3. AIRCRAFT AND FLEET CHARACTERISTICS  
(Poppoff et al., 1978)

Type	Nominal Mach No.	Nominal Altitude, km	Nominal Fuel Flow Rate, kg/hr/aircraft	$\text{NO}_x$ Emission Index, g $\text{NO}_2$ /kg	Nominal* Fleet Emissions $10^8$ kg/yr	
					$\text{NO}_x$	$\text{H}_2\text{O}$
A	2.7	20.0	37,800	15.6	1.47	125
				6.0	0.57	125
				2.0	0.19	125
B	2.3	17.5	35,200	18.0	1.65	117
				7.0	0.64	117
				3.0	0.27	117

\*100 Aircraft, 7 hours/day. From Poppoff et al. (1978)

The reported ozone depletions are given in Table 3-4. Results are given for the "Dickinson-Chang" profile (or Chang/1976), and for "WT" (Wofsy-type) profile.



TABLE 3-4. OZONE CHANGES CALCULATED FOR 100 AIRCRAFT  
WITH DIFFERENT NO<sub>x</sub> EMISSION INDICES

Type	Cruise Altitude, km	NO <sub>x</sub> E.I., g NO <sub>2</sub> /kg	Injections, 10 <sup>3</sup> kg/yr		% Ozone Change*			
					NO <sub>x</sub> only		NO <sub>x</sub> plus H <sub>2</sub> O	
					NO <sub>x</sub>	H <sub>2</sub> O	DC1	WT2
A	20.0	15.6	1.47	125	0.12	0.12	0.07	0.03
		6.0	0.57	125	0.05	0.05	0	-0.06
		2.0	0.19	125	0.02	0.02	-0.03	-0.08
B	17.5	18.0	1.65	117	0.13	0.13	0.10	0.06
		7.0	0.64	117	0.05	0.05	0.02	-0.02
		3.0	0.27	117	0.02	0.02	-0.01	-0.05

\*The Ames authors point out that these near-zero numbers, obtained by interpolation, involve substantial (fractional) uncertainty.

<sup>1</sup>This is referred to as the Dickinson-Chang profile; it has been referred to elsewhere as the "Chang/1976" profile (or at times as the "new" Chang profile).

<sup>2</sup>This is the NASA-Ames "Wofsy-type" profile, developed by NASA-Ames (see Section 3.3.3).

The results given in Table 3-4 are plotted in Fig. 3-6 for the two K<sub>z</sub> profiles. Note that the ozone column *increases* with increased NO<sub>x</sub> injection at constant water injection rate; the depletion appears to be due to the H<sub>2</sub>O injections. The NO<sub>x</sub> result is entirely opposite to that found in CIAP. The H<sub>2</sub>O effect on ozone was never clear in CIAP; in one paper however (Crutzen, 1974), it was reported that water vapor, according to then-current chemistry, actually increased ozone slightly. Prior to CIAP and the NO<sub>x</sub> issue, however, as noted in an earlier section, water vapor depletion of ozone was a major question with regard to the SST (Section 3.3.7).

Poppoff et al. (1978) also give effects as a function of NO<sub>x</sub> and H<sub>2</sub>O injection rate at 20 km in Fig. 3-7, and in Fig. 3-8 as a function of altitude, for a specified NO<sub>x</sub> injection rate. In Fig. 3-7, the water effects and NO<sub>x</sub> effects are computed separately. The scales are sized however for an NO<sub>x</sub> emission index

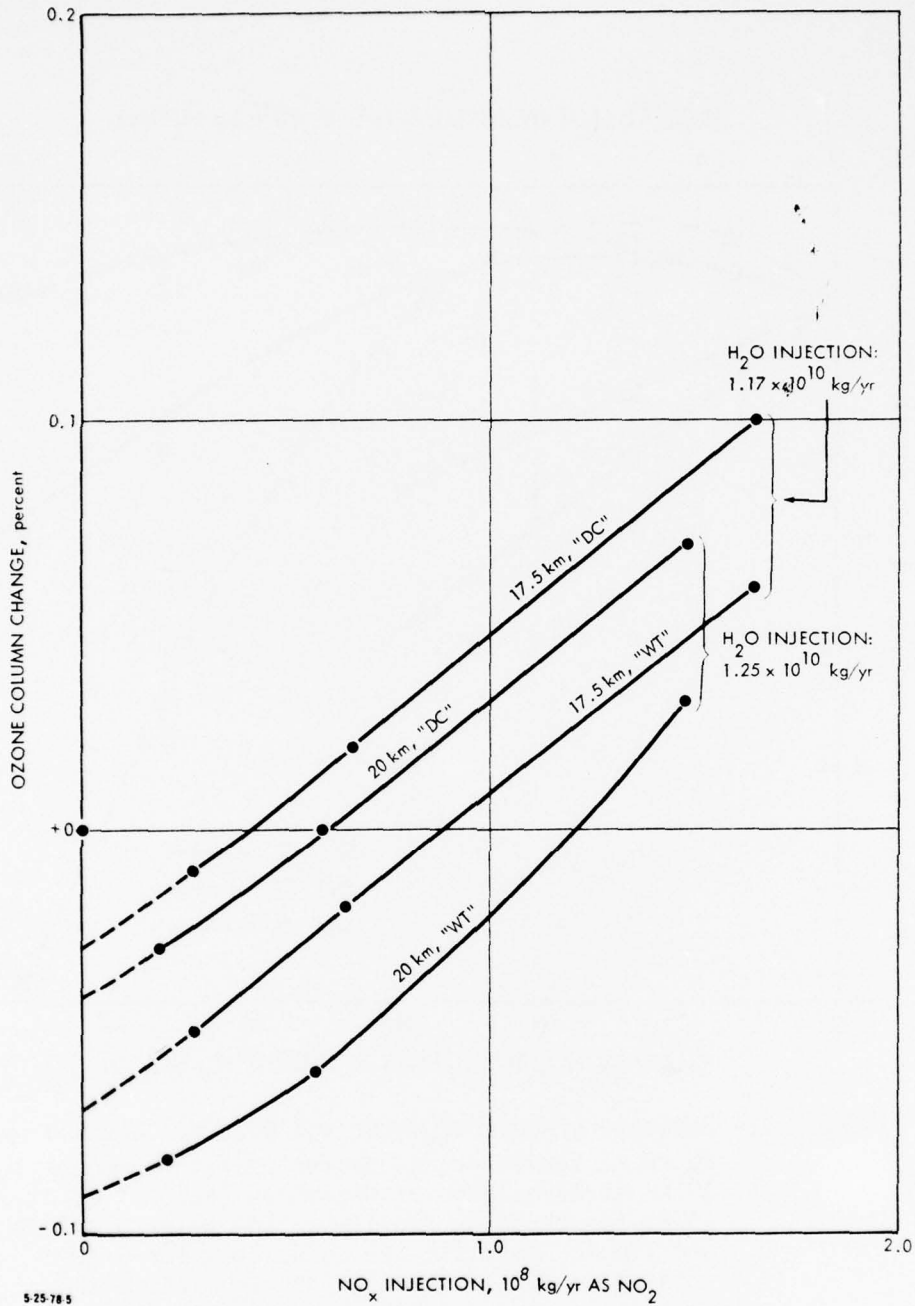

FIGURE 3-6. NASA-Ames 1-D model results plotted here to show effects of varying NO<sub>x</sub> injection rates at constant H<sub>2</sub>O injection rates. The water rates correspond to 100 SSTs at 17.5 and 20 km for Dickinson-Chang (DC) and Wofsy-type (WT) profiles. The points plotted involve approximations so the curves are not as precisely located as might be inferred.

Data Source: Poppoff et al., 1978 (see Table 3-4)

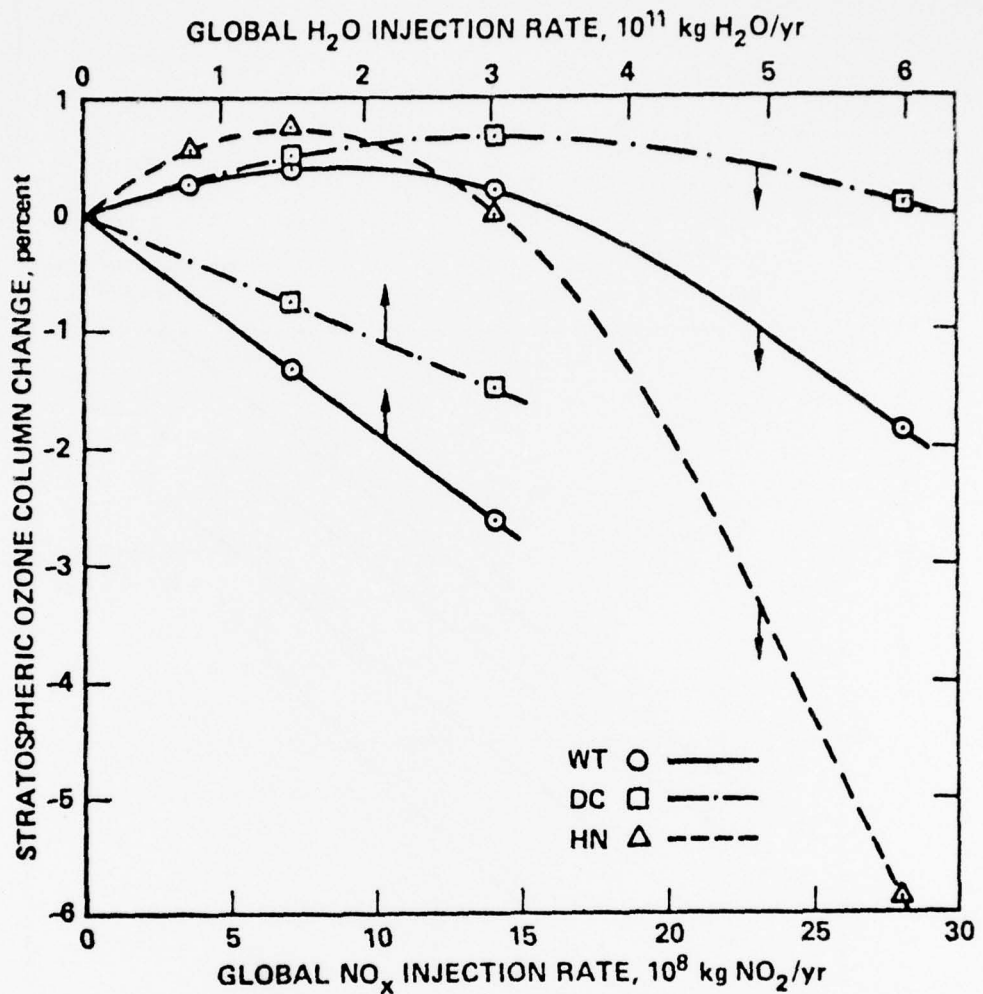

FIGURE 3-7. Separate effects of water and  $\text{NO}_x$  injections at 20 km at various rates on the ozone column, above 10 km as calculated at NASA-Ames (Poppoff et al., 1978) for three  $K_2$  profiles. The water abscissa and the  $\text{NO}_x$  abscissa are coincident for a  $\text{NO}_x$  emission index of 6 gm/kg (as  $\text{NO}_2$ ) and water emission index of 1.3 kg/kg. For other  $\text{NO}_x$  emission indices, the water effect should be scaled; e.g., the NASA "current" technology SST, the water effect is 6/15.6 or 0.38 times the value read at a given  $\text{NO}_x$  abscissa.

Data Source: Poppoff et al., 1978

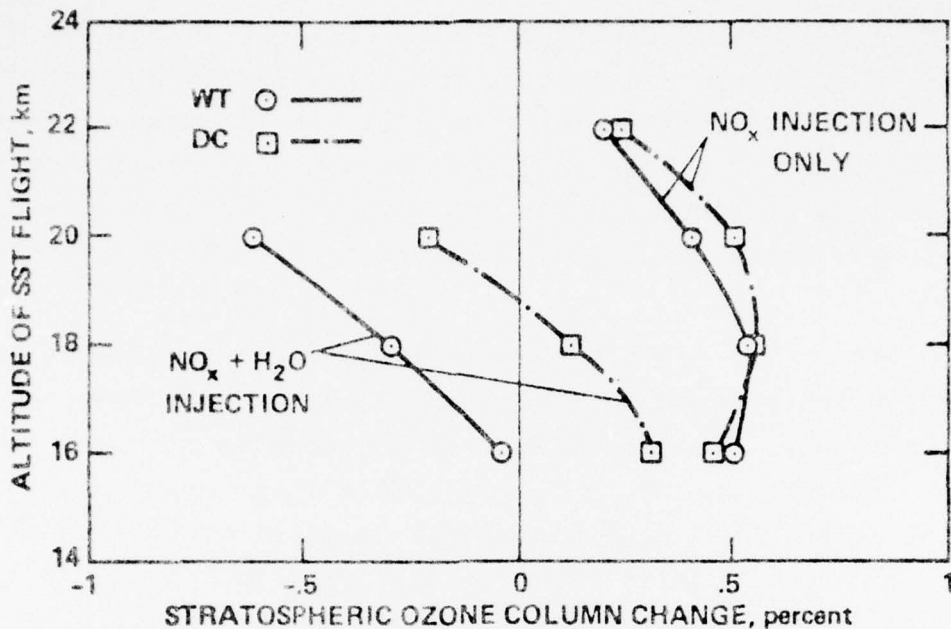

FIGURE 3-8. Effects of  $\text{NO}_x$  and  $\text{NO}_x$  and  $\text{H}_2\text{O}$  injections at various altitudes on the ozone column above 10 km as calculated by NASA-Ames (Poppoff et al., 1978). Results shown are for a  $\text{NO}_x$  injection of  $7 \times 10^8$  kg (as  $\text{NO}_2$ )/year and for this  $\text{NO}_x$  rate plus  $1.5 \times 10^{11}$  kg  $\text{H}_2\text{O}$ /year, for two  $K_z$  profiles. A  $\text{NO}_x$  emission index of 6 gm/kg fuel (as  $\text{NO}_2$ ) is implied.

Data Source: Poppoff et al., 1978

of 6 g  $\text{NO}_2$ /kg fuel. Note that the water effect is always negative and apparently linear, whereas the  $\text{NO}_x$  effect is distinctly nonlinear. Very high  $\text{NO}_x$  injection rates cause ozone depletion in all cases. Fig. 3-8 is for an  $\text{NO}_x$  injection rate of  $7 \times 10^8$  kg/yr and  $\text{H}_2\text{O}$  injection rate of  $1.5 \times 10^{11}$  kg/yr, corresponding to aircraft using advanced engines with an emission index of 6 g  $\text{NO}_x$ /kg fuel. Note for comparison that the injection rates used in Fig. 3-8 are over ten times those used in the Table 3-4, or some 1200 Type A SSTs at 20 km.

Note also that according to these results, an optimum  $\text{NO}_x$  emission index should exist, varying with selected  $K_z$  profile and fleet size, to provide minimum effect on the ozone column. This optimum is, of course, a "1-D" optimum, and should not be given too much credence. It is not obvious from these results that very low emission index values are a necessarily attractive goal.

Poppoff et al. (1978) give an extensive discussion of uncertainties and effects of various rate constants. They point out in particular the sensitivity of the results to the rate constant used for the  $\text{HO}_2 + \text{O}_3$  reaction. Their results are included as Table 3-5. Note the always deleterious effects of water vapor. For details other than those shown in the footnotes, the reader is referred to Poppoff et al., 1978. They also point out quite convincingly that estimates of uncertainties are unreliable and apt to be misleading.

c. Crutzen and Howard (1978). Crutzen and Howard studied ozone changes due to injections of  $\text{NO}_x$ ,  $\text{N}_2\text{O}$ , and chlorofluoromethanes. As noted in Table 3-2, a steady-state stratospheric model was used. A combination of concentration ( $\text{N}_2\text{O}$ ,  $\text{CH}_4$ ,  $\text{CO}$ ,  $\text{H}_2\text{O}$ ,  $\text{H}_2$ ,  $\text{CH}_3\text{Cl}$ ) and flux (odd nitrogen,  $\text{Cl}_x$ , ozone) boundary conditions was used at 10 km, the lower boundary. A major purpose was to investigate effects resulting from changes in the rate used for the  $\text{HO}_2 + \text{NO}$  reaction, and to consider effects due to other reaction rate uncertainties.

The authors chose equinox at  $40^\circ$  latitude as being representative of global conditions. Two eddy diffusivity profiles, differing only below 15 km were used to represent global average ( $K_z$  high) or conditions poleward of  $40^\circ$  ( $K_z$  low) as noted earlier. (See Section 3.3.4). An injection rate (over 1 km) of  $1000 \text{ NO molecules cm}^{-3}\text{sec}^{-1}$  and  $2 \times 10^5 \text{ H}_2\text{O molecules cm}^{-3}\text{sec}^{-1}$  was used in all cases; this corresponds to an injection rate of  $1.23 \times 10^9 \text{ kg NO}_2$  per year and  $9.64 \times 10^{10} \text{ kg H}_2\text{O}$  per year; a fuel

TABLE 3-5. SENSITIVITY STUDIES OF OZONE  
 PERTURBATIONS DUE TO SSTs<sup>1</sup>  
 (Source: Poppoff et al., 1978)

<u>Model Modification (noncumulative)</u>	<u>Stratospheric ozone column changes due to SST NO<sub>x</sub> injection without/with water vapor effect<sup>2</sup></u>
Increase background N <sub>2</sub> O by 50%	-0.35%/ -0.88%
Increase total chlorine to 5 ppbv <sup>3</sup>	+2.13%/ +0.42%
Eliminate chlorine nitrate formation	-0.80%/ -0.81%
Eliminate scattered radiation	+0.55%/ -0.54%
Eliminate diurnal effects	+0.30%/ -0.50%
Use Moortgat CH <sub>2</sub> O quantum yields <sup>4</sup>	+0.68%/ -0.38%
Include NO <sub>2</sub> NO <sub>2</sub> formation	+0.17%/ -0.74%
Decrease the HO <sub>2</sub> + O <sub>3</sub> rate by a factor of 3 <sup>5</sup>	-0.50%/ -1.10%
Increase the HO <sub>2</sub> + O <sub>3</sub> rate by a factor of 3 <sup>5</sup>	+1.80%/ +0.13% *
Increase the OH + HNO <sub>3</sub> rate by a factor of 3 <sup>6</sup>	-1.74%/ -1.90%
Decrease ambient H <sub>2</sub> O from 1.0 to 2.5 ppbv at 14 km	-0.07%/ -1.10%

<sup>1</sup>A global NO<sub>x</sub> injection rate of  $7 \times 10^8$  kg NO<sub>2</sub>/yr and  $1.5 \times 10^{11}$  kg H<sub>2</sub>O/yr at 20 km are assumed; the WT diffusion coefficient has been used for each sensitivity test. See Poppoff et al. (1978) for detailed discussion of these effects.

<sup>2</sup>For reference, the nominal ozone column changes are +0.40%/ -0.62%, respectively.

<sup>3</sup>An increase of about 3 ppbv.

<sup>4</sup>Represents an increase of about 50% (varying with altitude) in the yield of hydrogen radicals over baseline model values.

<sup>5</sup>The baseline HO<sub>2</sub> + O<sub>3</sub> rate is  $7.3 \times 10^{-14} e^{-1275/T}$  cm<sup>3</sup>/sec. Note that the corresponding tripled rate at 230 K is  $8.6 \times 10^{-16}$  cm<sup>3</sup>/sec, a rate which is lower than the value of  $1.1 \times 10^{-15}$  cm<sup>3</sup>/sec calculated from the Zahniser and Howard 1978 expression (Section 3.5.2a).

<sup>6</sup>The baseline OH + HNO<sub>3</sub> rate is  $8.0 \times 10^{-14}$  cm<sup>3</sup>/sec.

consumption of  $7.71 \times 10^{10}$  kg/year and an  $\text{NO}_x$  emission index of  $16.0 \text{ g NO}_2/\text{kg fuel}$  is also implied. The fuel flow corresponds to 684 of the type A aircraft (at 7 hours per day) described in the previous section. Injections at 13, 16, and 20 km were studied.

The effects due to variations in three reaction rates and the two eddy diffusivity profiles were computed. The three reactions and rate expressions used are as follows, using nomenclature as in Section 3.5.2.

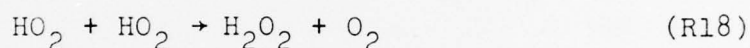
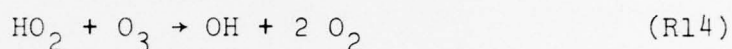
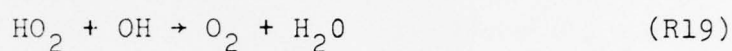

Reaction rate effect studies used the following values in  $\text{cm}^3/\text{molecule-sec}$ . The value at 230 K is shown as a representative stratospheric value.

	<u>Expressions</u>	<u>k 230 K</u>
$k_{19}(\text{ST})$	$= 2.1 \times 10^{-11}$	same
$k_{19}(\text{hi})$	$= 5.1 \times 10^{-11}$	same
$k_{14}(\text{ST})$	$= 10^{-13} \exp(-1525/\text{K})$	$1.3 \times 10^{-16}$
$k_{14}(\text{hi})$	$= 2 \times 10^{-13} \exp(-1250/\text{K})$	$8.7 \times 10^{-16}$
$k_{26}(\text{HE})$	$= 3 \times 10^{-11} \exp(-390/\text{K})$	$5.5 \times 10^{-12}$
$k_{26}(\text{C})$	$= 5 \times 10^{-12} \exp(-450/\text{K})$	$7.1 \times 10^{-13}$
$k_{18}(\text{ST})$	$= 5 \times 10^{-12} \exp(-500/\text{K})$	$5.7 \times 10^{-13}$
$k_{18}(\text{hi})$	$= 1.5 \times 10^{-11} \exp(-500/\text{K})$	$1.7 \times 10^{-12}$

Here "ST" refers to "standard" and "hi" to a "high" value; HE refers to the Howard and Evenson measurement (using a temperature coefficient consistent with an A factor of  $3 \times 10^{-11}$  and their value of  $8 \times 10^{-12} \text{ cm}^3/\text{sec}$  at 296 K); and "C" refers to an expression based on the Cox (1975) measured value.

The Crutzen and Howard results are summarized in Table 3-6.

TABLE 3-6. STRATOSPHERIC OZONE COLUMN CHANGES, PERCENT

Case	<u>1</u>	<u>2</u>	<u>3</u>	<u>4</u>	<u>5</u>	<u>6</u>
k <sub>19</sub>	ST	ST	hi	ST	hi	ST
k <sub>14</sub>	ST	ST	ST	hi	hi	ST
k <sub>26</sub>	C	HE	HE	HE	HE	HE
k <sub>18</sub>	ST	ST	ST	ST	hi	hi

Altitude Injection, km	K <sub>2</sub> , HIGH--POLEWARD 40°					
	13	-0.23	+0.07	-0.20	+0.71	+0.22
16	-1.15	-0.37	-1.03	+1.21	0	-0.39
20	-3.08	-1.55	-2.75	+1.11	-1.01	-1.64
	K <sub>2</sub> , LOW--GLOBAL					
13	-0.81	-0.26	-0.91	+1.67	+0.40	-0.24
16	-2.06	-1.05	-2.17	+2.19	+0.06	-1.05
20	-3.95	-2.37	-3.91	+1.82	-1.04	-2.41

The effect of the Howard and Evenson vs. Cox measurement of Reaction 26 is seen by comparing cases 1 and 2; the faster rate results in smaller, or opposite sign, effects on the ozone column. Note that the actual rate used in these calculations is less than the recommended NASA rate (Hudson, 1977) of  $8 \times 10^{-12}$ , which assumed no temperature correction.



The effects of the rate of Reaction 19 can be seen by comparing Runs 2 and 3. Note that the standard value for this reaction (Case 2) is taken by the authors to be  $2.1 \times 10^{-11}$ ; the recommended value by NASA (Hudson, 1977) is  $3 \times 10^{-11}$  and the only direct measurement (Burrows et al., 1977) is  $5.1 \times 10^{-11}$  (which is used in Case 3). Note that the rate for this reaction was taken as  $2 \times 10^{-10}$  in CIAP, resulting in large ozone depletions. Case 3 would seem to be reasonable as a perhaps conservative estimate.

The powerful effect of Reaction 14 can be seen by comparing cases 2 and 4, with a fast rate\* resulting in ozone enhancements at all altitudes. The reasons for this were discussed in Section 3.5.2. Note that the rate recommended in Hudson (1977) at 230 K is  $2.9 \times 10^{-16}$ , close to the geometric mean (3.3) of the two values (230 K) developed from the Crutzen-Howard expressions. Duewer et al. (previous section) use an expression which gives  $4.4 \times 10^{-16} \text{ cm}^3/\text{sec}$  at 230 K.

The small effects of the rate of Reaction 18 can be seen by comparing cases 2 and 6.

The effects of using all high values vs. all low values can be seen by comparing cases 1 and 5. Assuming  $k_{18}$  has little effect, Case 5 can be compared to Case 4 to again show the strong effect of Reaction 19.

The effect of a reduced effective transport rate at the tropopause can be seen by comparing the  $K_z$  high to the  $K_z$  low values. As most aircraft traffic is poleward of  $40^\circ$ , the  $K_z$  (high) values may be most appropriate, although the interpretation of these results is subject to some debate.

---

\*The "fast rate" used here is still slower than the  $1.1 \times 10^{-15} \text{ cm}^3/\text{sec}$  value found by Howard (1978). See Section 3.5.2.

Crutzen and Howard also show the vertical redistribution of ozone that takes place in Case 4 for 16 km injection (1.21 percent net increase). In this case, ozone was enhanced from 10 to about 27 km, above which ozone was depleted. Maximum percentage local ozone enhancement was 8.36 percent at 10 km, the lower model boundary.

Crutzen and Howard conclude that ozone enhancement from SST injections, accepting the Howard-Evenson measurement, would result only with some combination of a fast rate for  $\text{HO}_2 + \text{O}_3$  and a slow rate for  $\text{HO}_2 + \text{OH}$ . The high rate for  $\text{HO}_2 + \text{O}_3$  has, in fact, since been reported (Zahniser and Howard, 1978), as discussed earlier.

d. Lawrence Livermore Laboratory (LLL) Results (Luther, 1977). These workers have continued their extensive studies of atmospheric perturbations due to aircraft, halocarbons, and nuclear weapons tests, etc. Several aspects of their work are of particular interest here.

*Historical changes in aircraft ozone depletion results with changes in chemistry and  $K_z$  profile.* The LLL workers break their reporting of this work into two periods: 1974-1976, 1976-September 1977.

The LLL results for the 1974-1976 period, in which chlorine chemistry was not included, are shown in Fig. 3-9 for 17- and 20-km injections. The Chang/1974 profile results, with 1974 chemistry, represent the starting point; the second point (moving down) shows changes resulting from the use of the Chang/1976  $K_z$  profile (referred to by NASA-Ames in the previous section in the Dickinson-Chang profile), with the same chemistry. Other results, using the Chang/1976  $K_z$  profile, with changes in chemistry, are shown. The biggest single effect in this time frame was clearly the result of the revision of the  $\text{HO} + \text{HO}_2$  rate (R19) from  $2 \times 10^{-10} \text{ cm}^3/\text{sec}$  in CIAP to  $2 \times 10^{-11} \text{ cm}^3/\text{sec}$ , their then-preferred value. Note again that a somewhat higher

value ( $3 \times 10^{-11}$  cm<sup>3</sup>/sec) is recommended in Hudson (1977), and that both groups reject the only direct measurement of  $5.1 \times 10^{-11}$  (see Section 3.4.2). Details of the other rate changes are given in Luther (1977).

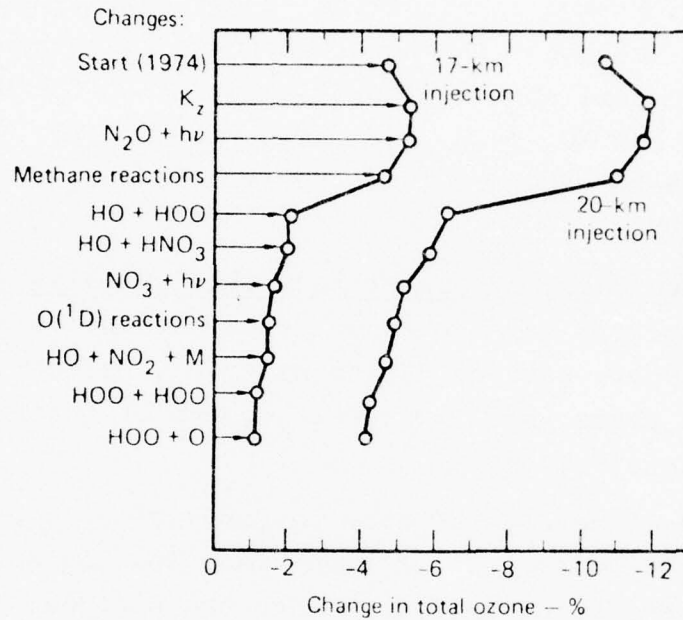

FIGURE 3-9. Changes in calculated ozone depletions over the 1974-1976 period due to various changes in modeling parameters. Global injection rate of  $NO_x$  (as  $NO_2$ ) taken as  $2.46 \times 10^9$  kg/yr. The  $K_z$  change refers to the Chang/1976 profile. See Luther, 1977, for details. See also Broderick, 1978.

Following this work, a number of changes were made to the LLL model, including the addition of multiple scattering, inclusion of chlorine chemistry, and modification of some additional reaction rates and absorption cross sections in accordance with the recommendations in Hudson (1977). (A rate of  $2 \times 10^{-11}$  cm<sup>3</sup>/sec was retained in these modeling exercises as the then-preferred LLL value; later runs have used  $3 \times 10^{-11}$ .) These changes resulted in an increase in ozone reduction for the same injection rate (2000 mol/cm<sup>3</sup>-sec over 1 km;  $2.46 \times 10^9$  kg/yr as NO<sub>2</sub>) from about 1.0 percent at 17 km and 4.0 percent at 20 km as in Fig. 3-9 to 1.3 percent at 17 km and 4.8 percent at 20 km, respectively. At this point, introduction of the Howard and Evenson rate constant had dramatic effects, as shown in Table 3-7, which table also includes LLL results using the Hunten/1975 K<sub>z</sub> profile. Note that these results include an assumed temperature coefficient for the Howard and Evenson measurement, reducing the rate at a nominal stratospheric temperature (230 K) to  $4.9 \times 10^{-12}$  rather than  $8.1 \times 10^{-12}$ , as recommended in Hudson (1977), and presumably reducing the magnitude of the change in effect; however, the slower rate used for the OH + HO<sub>2</sub> reaction works the other way.

TABLE 3-7. OZONE COLUMN CHANGES SHOWING EFFECTS OF THE HOWARD AND EVENSON (1977) REACTION RATE MEASUREMENT. GLOBAL NO<sub>x</sub> INJECTION  $2.46 \times 10^9$  kg/yr (Source: Luther, 1977)

K <sub>z</sub> Profile	NO <sub>x</sub> Injection Altitude (km)	Change in O <sub>3</sub> Column, %		Change in NO <sub>x</sub> , %	
		Old Rate*	HE Rate*	Old Rate	New Rate
Chang (1976)	20	- 4.79	0.55	46.7	47.9
	17	- 1.31	1.96	27.3	27.8
Hunten (1975)	20	-10.8	-6.90	96.2	97.1
	17	-4.35	0.83	61.4	62.3

\*The "old rate" used is  $2 \times 10^{-13}$  cm<sup>3</sup>/sec; the HE rate is based on the Howard and Evenson 1977 measurement, with an assumed temperature coefficient [ $4.28 \times 10^{-11} \exp(-500/T)$ ].

*Injection rate effects and modeling comments.* In studies under CIAP, ozone depletions calculated using 1-D models were generally found to be roughly linear with injection rate. Thus, the Hunten formula involved the expression

$$\delta = 1.405\chi - 0.0105\chi^2$$

where

$\delta$  = percent ozone depletion  
 $\chi$  = incremental mixing ratio of odd nitrogen, ppbv, which is proportional to injection rate

In the range of interest, the linear term dominated. Similarly, in correlating Chang's 1973-74 results, expressions were used of the type

$$\delta = a\chi_1^b$$

where  $\chi_1$  = annual injection rate and a and b are constants. Values of b ranged from 1.0 at 9 km to 0.89 at 23 km. (See pp. 3-32, Oliver et al., 1977).

With 1976 studies (see p. 3-70, Oliver et al., 1977) using the Chang/1976 profile, ozone column changes were found to be linear with injection rate at 17 km; however, nonlinearities were evident with the Hunten  $K_z$  profile. Introduction of the Howard-Evenson rate for the  $\text{HO}_2$ -NO reaction has now made non-linearity even more pronounced. This is shown by the LLL data given in Fig. 3-10 for 17- and 20-km injections of  $\text{NO}_x$  (and by the NASA-Ames results given earlier); the changes since the previous report (Oliver et al., 1977) are shown for convenience. Water injections are not included in Fig. 3-10 nor are thermal feedback effects. Note that the total enhancement with either profile is less than 1 percent for 20-km injections and (apparently) about 2 percent for 17-km injections. Note also the scale of the injections: 1000 molecules/cm<sup>3</sup>-sec over 1 km altitude corresponds to  $1.23 \times 10^9$  kg  $\text{NO}_x$  as  $\text{NO}_2$  per year. With the yearly  $\text{NO}_x$  emission figures (NAS, 1975) cited for Concorde,

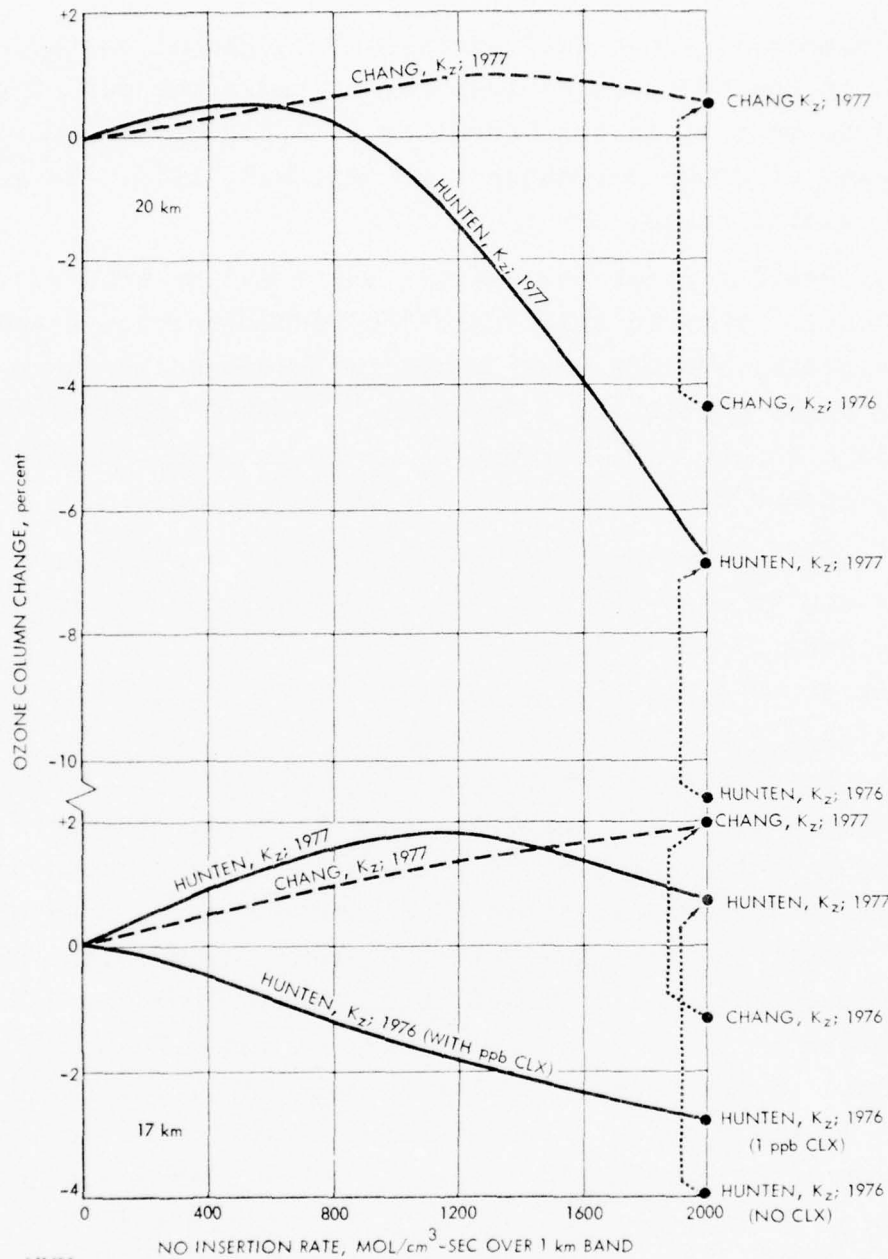

FIGURE 3-10. Ozone column changes for 17 and 20 km  $\text{NO}_x$  injections calculated at Lawrence Livermore Laboratory, using their 1-D model, for two eddy diffusivity profiles (Chang, 1976 and Hunter, 1974) with 1976 and 1977 chemistry sets. The 1976 values are taken from Table 3-20 (p. 3-65) (Oliver et al., 1977) for an atmosphere without chlorine. A number of changes were made in going to the 1977 results.

this corresponds to about 2000 aircraft on a global basis, or about 1000 in the Northern Hemisphere, if the ozone depletion is assumed to be that in the "corridor." A figure of 500 molecules/cm<sup>3</sup>-sec at 20-km corresponds to 375 (NAS, 1975) "large SSTs" on a global basis.

An interesting point now emerges which can be studied only in a 2-D model. This is that injection conditions could exist which on a global average basis would imply enhancement; however, this might consist of a "corridor" in which depletion occurs, and a larger area elsewhere, where enhancement occurs. Obviously, higher dimension model studies are needed.

Additional important points result from these LLL calculations. First, as has been mentioned earlier, the NO<sub>x</sub> injection alters the altitude distribution of NO<sub>x</sub>. This is shown in Fig. 3-11, which shows percentage changes in local ozone concentration for three injection rates with the Chang/1976 K<sub>z</sub> profile. The ozone concentration is increased at low altitudes and decreased at higher altitudes. The absolute concentration, of course, varies with altitude so that percentage changes in concentration cannot be interpreted directly in terms of column changes. Note also that even though the net effect on the ozone column might be zero in a 1-D model, a climatic effect could result from the altitude redistribution of ozone as well as from the added NO<sub>2</sub>, H<sub>2</sub>O and SO<sub>2</sub>. A final important point, already made, is illustrated in Fig. 3-11, in which ozone concentration changes near the tropopause (which in this author's opinion are best developed in a model such as this one, i.e., one with a troposphere), are given for the LLL 1-D model with several NO<sub>x</sub> injection rates at 20 km.

*Multiple scattering and surface albedo effects.* The LLL authors studied the effects of including or not including multiple scattering and of changes in surface albedo. Results for NO<sub>x</sub> injections were generally insensitive (approximately 1 percent increase) to these changes, although in one near-zero case,

the sign of the effect reversed (from -0.07 percent with pure absorption to +0.39 percent with multiple scattering and a surface albedo of 0.25. For halocarbon injections, however, the effect of multiple scattering is quite significant, increasing the depletion estimate by about 20 percent.

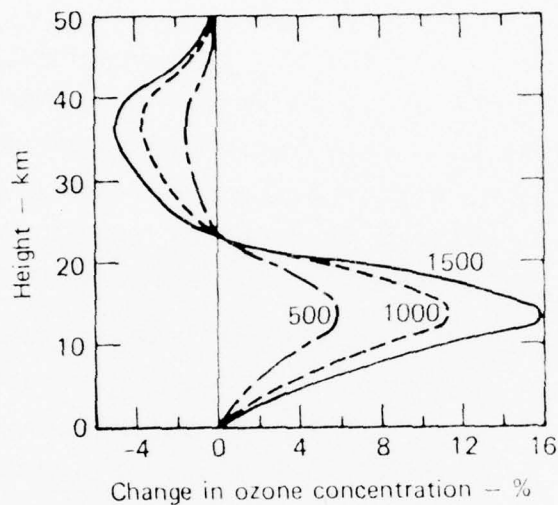

FIGURE 3-11. Percentage changes in ozone vs. altitude for three injection rates of  $\text{NO}_x$  at 20 km. The rates shown are in molecules/cm<sup>3</sup> sec over a 1 km band, and correspond to global injection rates of 0.62, 1.23, and  $1.85 \times 10^9$  kg  $\text{NO}_x$  (as  $\text{NO}_2$ ) per year. Chang/1976  $K_z$  profile.

Source: Lawrence Livermore Laboratory, 1978

*Water vapor injections and thermal feedback effects.* As was found earlier by Liu et al., 1976, increases in the stratospheric water vapor were noted to lead to a decrease in ozone in the NASA-Ames modeling work (Poppoff et al., 1978), as already discussed. These effects have been further investigated by LLL, including studies of thermal feedback effects, which later were not included in Poppoff et al. (1978).



The LLL results, including feedback effects for parameterized water contents with the Chang/1976  $K_z$  profile, and revised chemistry (from that used in Figs. 3-10 and 3-11), are shown in Fig. 3-12. Details of the chemistry used are given by Luther and Duewer (1978); important changes from the 1977 chemistry used in Figs. 3-9 and 3-10 include use of  $8.0 \times 10^{-12} \text{ cm}^3\text{-sec}^{-1}$ , independent of temperature for the  $\text{HO}_2 + \text{NO}$  reaction, and  $3 \times 10^{-11} \text{ cm}^3\text{-sec}^{-1}$  for the  $\text{HO}_2 + \text{OH}$  reaction. An  $\text{NO}_x$  injection of  $1000 \text{ mol/cm}^3\text{-sec}$  at 20 km was used for the injection studies. The results show that increases in water, with or without  $\text{NO}_x$  injections, reduce the ozone column; however, with thermal feedback, the effect on ozone of the increase in water content is largely eliminated.

The LLL investigators also report earlier computations of water effects using other chemistry sets, for both the Chang/1976 and Hunten/1975  $K_z$  profiles. Resulting effects were similar for the Chang/1976 profile but differed somewhat; the ozone was depleted by the degree of depletion decreased with increased  $\text{H}_2\text{O}$  with thermal feedback for the Hunten/1975 case. All such results are, of course, sensitive to the temperature coefficients used for the reaction rates and many of these are poorly established.

Wuebbles (1978) reports on later calculations carried out at LLL, in which the water increase was calculated rather than parameterized. The reaction rates used were those suggested by Hudson (1977), which are much the same as those used in the computations shown in Fig. 3-12. A  $\text{ClO}_x$  content of 1.7 ppbv ("current" levels) was assumed, along with the Chang/1976 profile. The computations included multiple scattering, but did not include thermal feedback. Results are shown in Table 3-8. Note that water and  $\text{NO}_x$  injection effects on ozone at 17 km are roughly additive, but somewhat less than additive at 20 km.

No results with the new model are available for the Hunten  $K_z$  profile.

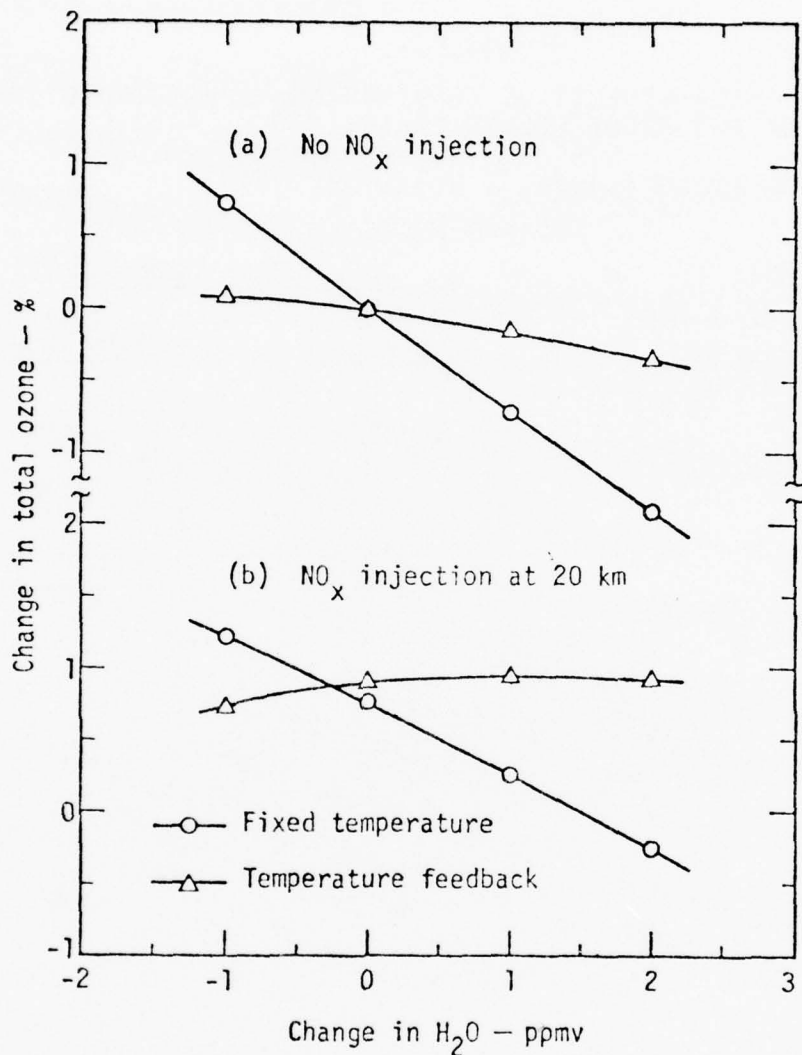

FIGURE 3-12. Lawrence Livermore Laboratory modeling results showing water effects on the ozone column with and without consideration of thermal feedback effects. Chang/1976 K<sub>z</sub> profile. NO<sub>x</sub> injection rate 1000 mol/cm<sup>3</sup>-sec over 1 km. For detailed chemistry, see Luther et al, 1977; critical rates include (in cm<sup>3</sup>/molecule-sec) 8.0 x 10<sup>-12</sup> for HO<sub>2</sub> + NO, 6 x 10<sup>-11</sup> for HO<sub>2</sub> + OH, and 7.3 x 10<sup>-14</sup> exp (-1225K) for HO<sub>2</sub> + O<sub>3</sub>.

TABLE 3-8. EFFECTS OF COMBINED NO<sub>x</sub> - H<sub>2</sub>O INJECTIONS  
ON THE OZONE COLUMN CHANGE/1976 K<sub>Z</sub> PROFILE;  
HUDSON, 1977 CHEMISTRY.  
(Source: Wuebbles, 1978)

Injection Rate mol/cm <sup>3</sup> -sec*		Ozone Column Change, %	
		17-km Injection	20-km Injection
NO <sub>x</sub>	1,000	1.57	1.47
H <sub>2</sub> O	0		
NO <sub>x</sub>	0	-0.16	-0.47
H <sub>2</sub> O	177,000		
NO <sub>x</sub>	1,000	+1.42	+1.11
H <sub>2</sub> O	177,000		
NO <sub>x</sub>	1,000	+1.13	+0.42
H <sub>2</sub> O	531,000		

\* Over a 1-km altitude band, 1000 mol/cm<sup>3</sup>-sec of NO<sub>x</sub> corresponds to 1.23 x 10<sup>9</sup> kg/yr (as NO<sub>2</sub>); 177,000 mol/cm<sup>3</sup>-sec of H<sub>2</sub>O corresponds to 8.5 x 10<sup>10</sup> kg/yr of H<sub>2</sub>O.

### 3.5.6 2-D Model Results

No 2-D model results incorporating both the Howard-Evenson rate and chlorine chemistry are available. A 2-D evaluation including these is underway at NASA-Ames; the evaluation will include Widhopf modeling results as part of their study. Widhopf and Glatt (1978) do report briefly on runs using the Howard-Evenson rate data, along with other revisions, but not including the very recent  $\text{HO}_2 + \text{O}_3$  measurement or chlorine chemistry. The run used a model fleet of both subsonic and supersonic aircraft and included both  $\text{H}_2\text{O}$  and  $\text{NO}_x$  injections; the fleet was that reported in Oliver et al., 1977, except that the  $\text{NO}_x$  injection rate above 15 km (the SST cruise component) was tripled. The prime differences from earlier results (Widhopf et al., 1977) was an increase in the total ozone column over and above that computed earlier. The total ozone column increased at  $40^\circ\text{N}$  by about 3.5 percent of the background in the fall vs. about 1.2 percent in earlier runs. A minimum in the increase was found in the winter with about 1 percent in the current result vs. about 0.4 percent earlier. The model suffered, as noted earlier, from an excess of ozone in the "natural" atmosphere.

### 3.6 VALIDATION ATTEMPTS

Studies of model estimates of ozone depletion for "known" events for use in comparison with the ozone record have continued. These include effects of the solar proton event of August 1972, of atmospheric nuclear weapons tests in the early 1960s, and estimates of ozone depletion at about 40 km due to increasing halocarbon production.

The August 1972 solar proton event and its effect on ozone near 4 mbar was described and compared to satellite observations by Crutzen et al. (1975) and by Heath, Krueger, and Crutzen (1976). The work has been updated with current chemistry by Borucki et al. (1978) in a 2-D model. In the Crutzen et al. studies, reasonable agreement (with some ambiguities) between

theory and observation could be argued, at least over the early period following the events. The Borucki et al. work showed that the new chemistry has little effect on the results for  $\text{NO}_x$  perturbations at the altitudes involved; substantial unexplained discrepancies, especially at low altitudes, were noted (R.C. Whitten, private communication, 1978).

Injections of  $\text{NO}_x$  from nuclear weapons tests in the 1958-62 period have also been studied by several groups, following a suggestion by Foley and Ruderman in 1972 (see Foley and Ruderman, 1972, 1973; Bauer and Gilmore, 1975; COMESA, 1975; NAS, 1975). Only 1-D model studies have been performed, although there is evidence (see Appendix B) that the season and latitude at which the explosion takes place is important. Model studies showed that hemispheric average depletions of the order of 6 to 8 percent should have occurred, but whether there was any evidence that it did occur can be debated (see Bauer and Gilmore, 1975; NAS, 1975, Angell and Korshover, 1977). The measurement by Howard and Evenson (1977) of a much faster rate for the  $\text{HO}_2 + \text{NO}$  reaction than thought earlier, led to an immediate possible explanation for the apparent discrepancy, because it implied a much lower sensitivity of the ozone column to  $\text{NO}_x$  injections. Calculations by LLL (Chang et al., 1978) have indeed shown a lesser sensitivity, with reduction in estimated effect to about 2-4 percent, depending on (unknown) stabilization altitudes for an  $\text{NO}_x$  cloud. The 2 percent lower value would not be inconsistent with observations (Angell and Korshover, 1977); within the uncertainties, then, the LLL authors argue that there are not necessarily any incompatibilities between theory and observation.

It should be noted at this point that a major point made in NAS (1975) is not discussed in Chang et al. (1978), and relates to solar cycle effects on ozone; a missing "increase" is noted by NAS. Indeed, substantial variations in total ozone

might be expected if the solar ultraviolet and the ozone column variation with time is as large as may be the case (global ozone changes of 7 percent or more, solar maximum to solar minimum, Callis and Nealy, 1978). This variation, which is quite uncertain, represents the largest known potential source of ozone variability during the 1955-1975 time period (see Bauer, 1978). Obviously, if an ozone record is to be examined for comparison with models, all such variations with time should be considered.

Finally, a perhaps more significant discrepancy lies in the ozone records versus the model results in terms of the halocarbon problem. Thus, Crutzen et al. (1978) compute that ozone decreases of 0.65 percent per year should have been occurring at about 40 km due to transport of Cl species from halocarbons released at the surface. However, during this same period, based on Umkehr records, Angell and Korshover (1977) show a general upward trend, as does Pittock (1977), based on balloon flights over Aspendale, Australia. Taken at face value, these observations would represent a serious challenge to the ClX theories. Questions about the Umkehr data, however, and other possible reasons for observed changes, preclude any such conclusion.

These various model validation questions are all evidently confounded by a variety of time-varying phenomena (see Bauer, 1978). A critical requirement would seem to be the difficult one of establishing solar ultraviolet variability with time, preferably as a function of sunspot number or some other easily identifiable variable.

## 4. CLIMATIC EFFECTS

### 4.1 INTRODUCTION

Little specific research attention has been given to the potential climatic effects of aircraft exhaust in the period since the cut-off date (December 1976) for input to our previous report (Oliver et al., 1977). The reasons for this, of course, relate to the complexity of the climate problem in general, to the lack of an immediate or evident threat from aircraft, and to the finite nature of resources with which to study aircraft effects; in addition, from a national standpoint, interest has moved into problems of more immediate policy relevance, principally the potential effects of halocarbons and of increases in atmospheric carbon dioxide. Even for these however, the actual level of climatic modeling work accomplished has been modest (although further work is certainly in the planning stage) and quite cautiously reported. (See e.g., NAS, 1976; NAS, 1977.)

In view of this general lack of new work specific to aircraft climatic effects, there would seem to be little to discuss. This is not quite the case, as climate modeling and climate research, wherever done, are applicable in general to a variety of problems. Furthermore, it seems appropriate to devote a few paragraphs to the ensemble of current climatic threats, and to note the common and uncommon features of the aircraft threat vis-a-vis the others. In addition, there have been some studies of rather direct (if not necessarily quantitative) relevance, and some apparent trends in the treatment of the general problem seem worthy of note. These follow in the order just mentioned.

#### 4.2 THE VARIOUS (AND CHANGING) "THREATS" TO OZONE AND CLIMATE

A number of the various "threats" postulated (in recent years) to climate and ozone are given in Table 4-1, along with some characteristics as now perceived. Note that any material which affects ozone, either in total column or in altitude or latitudinal distribution, also affects climate; similarly, any factor causing a change in climate--or a change in stratospheric temperatures--will affect this ozone column.

The aircraft threat ( $\text{NO}_x$ ) is shown in Table 4-1 as leading to an increase in ozone, a result shown by at least some models (see Section 3), even for aircraft operating at 20 km. For  $\text{N}_2\text{O}$  from fertilizer or power plants (directly from combustion, or indirectly from fixed nitrogen), the table shows a decrease in ozone, but the chemistry as used in the calculations on which this result is based is in need of revision; some models do show an increase. From a climate (mean temperature) standpoint, both aircraft effluents and  $\text{N}_2\text{O}$  increases may well result in warming, although in both cases a "netting out" of cooling and warming effects involved: for aircraft, see Oliver et al., 1977; for  $\text{N}_2\text{O}$ , the tropospheric greenhouse effect of added  $\text{N}_2\text{O}$ , which absorbs at 7.78  $\mu\text{m}$  in a "partial window" and also at 17  $\mu\text{m}$  and 4.5  $\mu\text{m}$ , all in the infrared, probably more than compensates for the cooling which would be expected if stratospheric ozone is depleted. No model calculations including both these effects are known to this author; however, Yung et al., 1976, indicate 0.5 to 0.75 K warming with a doubling of  $\text{N}_2\text{O}$ , whereas Crutzen and Howard (1978), indicate *at most* a 10 percent reduction in stratospheric ozone for a doubling of  $\text{N}_2\text{O}$ . A 10 percent reduction of stratospheric ozone may involve a cooling of the order of 0.1 K (see Oliver et al., 1977, pp. 4-10, 4-11) ignoring ozone altitude redistribution effects,  $\text{NO}_2$  changes, etc.



TABLE 4-1. A COMPARISON OF ANTHROPOGENIC EMISSIONS AS THREATS TO OZONE AND CLIMATE\*

Source	Aircraft <sup>1</sup> (cruise)	Aerosol Propellants, etc.; <sup>2</sup> Space Shuttle	Power Plants <sup>1</sup> (fossil fuels)	Fertilizers <sup>1</sup> (nitrogenous)	Power Plants <sup>1</sup> (nuclear)
Pollutants	NO <sub>x</sub> , H <sub>2</sub> O, SO <sub>2</sub> , soot, particulates, CO <sub>2</sub>	Cl <sub>2</sub> , BrO <sub>x</sub>	CO <sub>2</sub> , aerosols, N <sub>2</sub> O, NO <sub>x</sub> , SO <sub>2</sub> , CO <sub>2</sub> , H <sub>2</sub> O, waste heat	N <sub>2</sub> O, (NO <sub>x</sub> ) <sup>3</sup>	Radionuclides <sup>4</sup> (K <sup>85</sup> , H <sup>3</sup> , C <sup>14</sup> ), waste heat
Ozone column effects	Increase (?) (small)	Increase (potentially large)	Increase slightly, (unless N <sub>2</sub> O counters) <sup>2</sup>	Decrease (?)	(?) (NO <sub>x</sub> production) OH
Climatic effects (probable)	Warming (?) <sup>5</sup>	Warming <sup>6a</sup>	Warming (potentially large)	Warming <sup>6b</sup>	?
Pollutant source altitude	6-20 km	Surface	Surface	Surface	Surface
Pollutant sink altitude	~ 3 km <sup>6</sup>	30-40 km (initial) ~ 3 km (final) <sup>7</sup>	Surface (oceans, plants)	Stratosphere <sup>8</sup>	Distributed decay
Atmospheric response/ recovery time	2-5 yr	50-100 yr	100+ (?) yr	10-100(+) yr	Decades
Special aspects and uncertainties	Tropopause height, transport, upper troposphere chemistry, sources concentrated by latitude, 2-D, 3-D effects, emission forecasts and measure- ments	Tropospheric sinks (if any)	CO <sub>2</sub> material balance, equilibrium with oceans, geophysical effects	Unknown sinks for N <sub>2</sub> O, equil- ibration time with N reser- voirs	Atmospheric elec- tricity, ions affecting clouds, transport (?)
Common aspects	Atmospheric chemistry transport, climatic phenomena, biospheric impact (if O <sub>3</sub> decreases)	Atmospheric chemistry, trans- port, climatic, biospheric impact	Climatic phenomena	Chemistry, trans- port, biospheric impact (if ozone decreases)	?

\* An early version of this table was included in the HAPP Status Report, December 1977, FAA AEO 77-16.

<sup>1</sup>Principal threat materials (in this context) underlined.

<sup>2</sup>The Space Shuttle will introduce chlorine compounds (plus water and NO<sub>x</sub>) into the upper atmosphere. Effects relative to halocarbons are thought to be small.

<sup>3</sup>NO reacts in the stratosphere with O(1D) to form NO<sub>2</sub>, which eventually is transported to the troposphere and rained out. Recent models suggest an ozone increase, earlier models a decrease.

<sup>4</sup>Release depends on reprocessing procedures.

<sup>5</sup>Multiple effects: Cooling due to stratospheric aerosols and if ozone is depleted; warming due to H<sub>2</sub>O, contrails, NO<sub>2</sub>, and O<sub>3</sub> if O<sub>3</sub> increases.

<sup>6a-b</sup>Warming by tropospheric greenhouse effect (6a), Ramanathan, 1975; 5b, Yung et al., 1976) very likely exceeds any cooling due to ozone reduction in the stratosphere.

<sup>7</sup>Assumed rainout altitude.

<sup>8</sup>The known sources and sinks for N<sub>2</sub>O are in poor balance. The known stratospheric sinks (principally photolysis) are too small and tropospheric sinks are not established.

The threat to ozone involving stratospheric chlorine or bromine is currently--as a result of several revisions in reaction rates--considered to be larger per unit of halogen added than at the time of the NAS (1976) report. However, the actual magnitude of the expected threat is probably down somewhat, due to regulatory actions with regard to aerosol sprays already announced or recognized to be necessary.\* From a climate standpoint, the halocarbon threat is again a combined one, with a tropospheric greenhouse (warming) component due to undissociated halocarbons (primarily resulting from absorption by the C-F bond) again very likely exceeding the cooling effects due to reductions in stratospheric ozone. (See Ramanathan, 1975, for greenhouse effects.)

Fossil-fueled power plants produce  $\text{CO}_2$ ,  $\text{N}_2\text{O}$ ,  $\text{NO}_x$ , water vapor, aerosols (ash),  $\text{COS}$ ,  $\text{SO}_2$ , etc. The  $\text{CO}_2$  is thought to be the most significant climatic component, one creating considerable concern for the future (particularly sometime after the year 2000) with substantial warming expected if, e.g., the current  $\text{CO}_2$  content should double, and low cloudiness should remain unchanged.\*\* [It is of interest however that Smagorinsky, an outstanding authority on climate modeling, provided the most cautious view on the effects to be expected of all of those reported in NAS, 1977.]† A considerable effort is planned for

---

\* In the U.S., bulk production of chlorofluorocarbons intended for "nonessential" use, principally aerosol propellants, is to be halted October 15, 1978. The manufacture of products containing these propellants is to cease December 15, 1978, but other uses for fluorocarbons are growing, so the problem is still of considerable significance.

\*\* A rather small increase (a few percent) in low cloudiness would compensate for a doubling of  $\text{CO}_2$  content, according to the Manabe and Wetherald (1967) model results.

†See also Section 4.3.2 below for a relevant and basic critique offered by Robinson, 1978.

the CO<sub>2</sub> problem; however, a CO<sub>2</sub> budget question (Kerr, 1977; Woodwell, 1978) exists which must (or should) first be resolved. One power plant exhaust ingredient, COS, has no known tropospheric sink, is not removed by lime scrubbers, and will presumably increase the stratospheric aerosol layer with some compensating (cooling) effect. The fly ash and SO<sub>2</sub>-derived aerosols would also have some effect--whether warming or cooling is perhaps controversial--but these will likely be removed from the stack gas by scrubbers and precipitators. It is of interest, as pointed out by Robinson (1977), that the net loss in solar radiation due to sulfuric acid aerosols (assuming 2.5 percent sulfur in the coal and no scrubbers) could exceed the heat released by combustion, arguing that these effects should not be considered in isolation. An increase in CO<sub>2</sub> will cause a cooling of the stratosphere, with a reduction in thermal reaction rates of ozone-destruction cycles, resulting in a slight increase in ozone (*ceteris paribus!*).

Nuclear power plants, whatever their other aspects might be, are not normally considered to be a threat to ozone or to climate, except for waste heat effects. However, as pointed out by Boeck (1976) such plants do generate, and waste fuel reprocessing could release, Kr-85 which is a  $\beta$  emitter with a 10.8 year half life. Kr-85 would affect atmospheric electricity, with unknown, but possibly important, effects (see Markson, 1978); also, some NO would be formed as the principal  $\beta$  (0.249 MEV) is slowed in the air. Both climate and ozone could be affected by the various processes involved. With care, of course, Kr-85 could be largely contained rather than released to the atmosphere.

These various threats have common and unique features. All, of course, involve much the same chemistry and physics, and all could impact similarly on the biosphere if, e.g., there is a general warming, or a destruction of stratospheric ozone,

etc. But there are important differences both in a geophysical and policy sense. Thus, aircraft sources are concentrated in mid-latitudes with effluents that have a short life in the troposphere; halogen and  $N_2O$  sources involve surface releases of materials with long tropospheric lives and with stratospheric destruction. Carbon dioxide is inert in the atmosphere but is absorbed by (growing) plants and the oceans. These differences mean that effects will differ relatively with latitude and response and recovery times will also differ. From a policy point of view, it is important to know whether the atmosphere would recover in 5 years or 100 years if an error were made. Aircraft, of course, have long life times (approximately 20 years) and policy decisions are difficult to reverse; should it prove necessary, the atmosphere would recover if the polluting source were discontinued, much more rapidly in the case of aircraft than in the case, e.g., of halocarbons.

#### 4.3 CLIMATE AND CLIMATE MODELING - SOME DEVELOPMENTS OF INTEREST

##### 4.3.1 Scope

Climate modeling and the study of climates are fields in their own right, and no attempt will be made here to assess the real or potential significance in evaluating aircraft effects of the various publications in this field. A few papers have touched on matters of evident interest, and some comments on these matters follow.

##### 4.3.2 Predictability of Climate Change

In a particularly sobering paper, Robinson (1978) examines the prediction equations for complicated hydrodynamic flows "in a critical and didactic manner." His conclusions are obviously pertinent to the entire modeling problem, and seem to be best presented by direct quotation:

"The only logically valid prediction with the types of equations now used in meteorological practice is one of no change.

"Predictive equations ostensibly based on dynamics are empirical and must be validated empirically.

"...Other predictive schemes merit a priori the same careful consideration as those ostensibly based on dynamics.

"Empiricism, in itself, does not limit the value of a predictive scheme but it does impose stringent requirements for validation. The implications of this are particularly disturbing in the context of understanding and predicting climate change, where the historical record is insufficient to provide useful validating statistics, unless, as seems unlikely, it can be greatly improved in detail. Validation of an empirical method of climate prediction must proceed simultaneously with its application. Several prediction intervals must elapse before the performance of the method can be assessed; for example, skill in predicting decadal averages might begin to be quantified after a century of application. There is no reason to expect a more rapid resolution; even if the relevant atmospheric statistics are stationary, the integral time scale is certainly more than a century."

Robinson's critiques must obviously be kept in mind when climate change estimates are offered. As Robinson indicates, however, the third statement above represents the positive implication of his arguments. In effect (and Robinson does not make the statement), it might be argued that relatively simple formulations compared to large general circulation models (such as 1-D or 2-D models) may provide useful, if not necessarily quantitatively reliable, information; in a sense, all such predictive techniques must await validation and any prediction at the present state of understanding (in this author's opinion)

should be considered primarily as a measure of risk rather than as a quantitative prediction. Other, perhaps more pragmatic, aspects and results, follow.

#### 4.3.3 Stratospheric Aerosol Effects

The principal climatic effort in CIAP was in studies of the effects of aerosols resulting from fuel sulfur in SSTs, (see Oliver et al., 1977). The conclusion reached in CIAP was that such aerosols will cause a cooling effect at the surface. The water-vapor-induced warming was argued in CIAP to be smaller than the cooling effect of the aerosols; a reexamination in our previous report (Oliver et al., 1977) however, recognizing sedimentation effects and attempting internal consistency in the treatments, suggested that the warming effects were probably larger. No studies (of which we are aware) have been undertaken to resolve this disagreement. Studies have, however, been reported which pertain specifically to aerosol effects. It is of interest that there now seems to be agreement that stratospheric aerosols do cause some cooling effect. The quantification of this effect, however, for a specified fleet, remains highly uncertain, because both steady-state burdens and effects per unit mass involve many unknowns.

A paper of specific and general climatological interest is that of Mass and Schneider (1977). These authors in a follow-up study to an earlier paper (Schneider and Mass, 1975) report on statistical evidence as to the influence of sunspots and volcanic dust on long-term temperature records. The authors conclude that their earlier (1975) conclusions, which showed a dominant effect of sunspots, does not hold up on critical examination; they do find, however, that a volcanic signal can be weakly detected in the temperature records. This result thus minimizes questions associated with numerous contentions or analyses by other authors who have studied effects of volcanic dust, and who have largely or totally ignored sunspot

numbers (e.g., Lamb, 1972; Mitchell, 1961, 1970; Oliver, 1976; Bradley and England, 1978). It is also of interest that Livingston (1978) has recently reported measurements which indicate a cooling of the sun's photosphere with increased sunspot activity, rather than a warming, as required; e.g., if the "Little Ice Age" is to be explained by the lack of sunspots during the Maunder Minimum (Schneider and Mass, 1975).

A second paper requiring comment is that due to Hamill, Toon, and Kiang (1977). These authors have examined in detail the microphysical processes affecting stratospheric aerosols, specifically those composed of sulfuric acid and water, such as would result from  $\text{SO}_2$  effluent from aircraft. The authors consider the altitude region in which nucleation of such particles takes place and find that it corresponds to that region of the stratosphere where such particles are generally found. Various features of the aerosol layer can be explained by the analyses. Of particular interest is their observation that such droplets are unstable--i.e., they will evaporate--at higher altitudes, above about 30 km, and that such particles will grow with time at lower altitudes, depending on the ambient  $\text{H}_2\text{SO}_4$  vapor pressure. Computations of residence times and injection coefficients for particulates, such as those by Bauer and Gardner (Appendix D in Oliver et al., 1977), assuming such particulates to be inert, thus cannot hold for sulfuric acid aerosols. Hamill et al. (1977) point out some of the still outstanding questions about their modeling work, among which is the role and importance of  $(\text{NH}_4)_2\text{SO}_4$  at various altitudes. Analyses of such particles are provided by Farlow et al. (1977); these authors report finding various insoluble materials in the particles and conclude that sources other than volcanoes contribute significantly to such aerosols. The aerosols, in general, were found to be mixtures of solids and liquids rather than pure sulfuric acid.

A 1-D aerosol model based on this and additional analysis has been developed by the same group (Turco et al., 1976).

#### 4.4 A SOVIET VIEW

Budyko and Karol (1976) in a review of CIAP research, and Budyko (1977) in an article on present-day climatic changes, present views on climate modification which differ from that presented in CIAP and elsewhere. Since stratospheric pollution problems are global in nature, and agreement must be multi-national, it seems important that these views be recognized.

In Budyko and Karol (1976), the climatic impact of aerosols and water vapor as presented in CIAP are reviewed. A case is drawn from CIAP which indicated by the year 2000 that a drop in the average air temperature of  $0.16^{\circ}\text{C}$  would result from aircraft-generated aerosols. They note a cooling of about  $0.1^{\circ}\text{C}$  (including  $\text{NO}_2$  compensation), due to 10 percent ozone reduction, and a warming of  $0.1$  to  $0.2^{\circ}\text{C}$  from water vapor. They then state "Thus, the total effect of the influence of the change in the mass of the ozone and water vapor on thermal condition may prove to be insignificant even with high levels of aircraft propulsion effluents." [Note that this interpretation differs from that in CIAP, where (p. 74, Grobecker et al., 1974) it was argued that  $\text{NO}_2$  increases compensated for ozone decreases, and temperature changes due to ozone changes were not treated.]

After further discussion of various other aspects of the CIAP work, Budyko and Karol (1976) note that the effects of sulfate aerosol obtained by CIAP agree reasonably well with their own independent estimates. They then note the possibility of a "directed impact" on climate due to the burning of sulfur in the lower atmosphere, and argue that another circumstance is of essential importance to an evaluation of the conclusions of the CIAP research. This circumstance is the expected increase in temperature due to increases in carbon dioxide from combustion



of fossil fuels, and they point out that the increase in expected temperature of 0.5 to 1.0°C exceeds the cooling due to stratospheric aircraft. This warming would result in reduced precipitation in mid-latitudes, with "substantial losses in the economies of many countries."\* The stratospheric aviation effect may then prove to be, first, insignificant compared to other changes, and second, the aerosol may diminish the CO<sub>2</sub>-induced tendency towards warming. They point out that the second effect was noted by them earlier, and give references.

In the later paper, Budyko (1977)\*\* argues for the coupling of climate theory with economic aspects. He includes plots which show that as the mean annual temperature anomaly for the northern hemisphere (and for 75-85°N) increased (since 1883) the precipitation in mid-latitudes decreased; decreases in integrated precipitation (as measured by the Caspian sea level) correlated with decreases in wheat yield. He then discusses climate models, effects of atmospheric transparency and changes in cloudiness and albedo, examines data, and concludes that, at least for periods over which the ice-albedo feedback is small, climate models satisfactorily explain natural changes and are thus capable of predicting anthropogenic factors on climate. He considers CO<sub>2</sub> and aerosol (tropospheric) effects on climate, and warns that warming may result with a decrease in rainfall in mid-latitudes (presumably leading to reduced food production). He then refers to his earlier works, and points out that an increase in stratospheric aerosol could be effected to counter the effects of CO<sub>2</sub> warming.

\* Budyko and Karol also criticize the CIAP investigators for not including in their evaluation the increased rainfall in mid-latitudes with global cooling, even though the information, in their view, was available to the CIAP investigators.

\*\* According to *Tellus*, the manuscript was received November 19, 1975 and in final form June 4, 1976.

## REFERENCES

Ackerman, M., D. Frimout, C. Muller, "Stratospheric CH<sub>4</sub>, HCl and Cl) and the Chlorine-Ozone Cycle," *Nature*, Vol. 269, September 15, 1977.

Anderson, J.G., "Free Radicals in the Stratosphere: HO<sub>2</sub>, OH, ClO, Cl, O, NO," presented at the World Meteorological Organization Symposium on the Geophysical Aspects and Consequences of Changes in the Composition of the Stratosphere, Toronto, Canada, p. 53, June 26-30, 1978.

Anderson, J.G., "The Absolute Concentration of OH(X<sup>2</sup>π) in the Earth's Atmosphere," *Geophys. Res. Lett.*, Vol. 3, No. 3, pp. 165-168, March 1976.

Anderson, J.G., J.J. Marsitan, D.H. Stedman, "Atomic Chlorine and the Chlorine Monoxide Radical in the Stratosphere: Three In-situ Observations," *Science*, Vol. 198, pp. 501-503, November 4, 1977.

Angell, J.K., and J. Korshover, "Recent Trends in Total Ozone and Ozone in the 32-46 km Layer," presented at the World Meteorological Organization Symposium on the Geophysical Aspects and Consequences of Changes in the Composition of the Stratosphere, Toronto, Canada, p. 107, June 26-30, 1978.

Angell, J.K., and J. Korshover, *Global Ozone Variations: An Update into 1976*, Air Resources Laboratories, ERL, NOAA: Silver Spring, Maryland, November 1977 (unpublished).

Angell, J.K., and J. Korshover, "Quasibiennial and Long-Term Fluctuations in Tropopause Pressure and Temperature and the Relation to the Stratospheric Water Content," *Mon. Wea. Rev.*, Vol. 102, pp. 29-34, 1974.

Athens, P., P. Gott, P. O'Farrell, and B. Huckins, *Stratospheric Emissions Due to Current and Projected Aircraft Operations*, Arthur D. Little, Inc., Cambridge, Massachusetts, DOT-FA76WAI-603, August 1976.

Bauer, E., *A Catalog of Perturbing Influences on Stratospheric Ozone, 1955-1975*, IDA Paper P-1340, September 1978.

Bauer, E., R.C. Oliver, W. Wasylkiwskyj, "On the Use of Zr-95 Data from Chinese Atmospheric Nuclear Explosions to Study Stratospheric Transport in a One-Dimensional Parameterization," *J. Geophys. Res.*, Vol. 83, No. C8, pp. 4019-4028, August 20, 1978.

Bauer, E., and F.R. Gilmore, "Effect of Atmospheric Nuclear Explosions on Total Ozone," *Revs. Geophys. Space Phys.*, Vol. 13, No. 4, pp. 451-458, August 1975.

Beadle, P.C., *Concorde Fuel Usage and Emissions Latitudinal and Seasonal Variation for Atmospheric Modelling, An Analysis of Current and Probable British Airways and Air France Route Networks*, Environmental Sciences Group, Commercial Aircraft Division, British Aircraft Corp. Ltd., B30/PCB/479, July 1977.

Benson, R., and G.S. Samuelson, *Oxides of Nitrogen Transformation While Sampling Combustion Products Containing Carbon Monoxide, Hydrogen, and Hydrocarbons*, UCI Combustion Laboratory, Irvine, California, April 1977. Presented at the 1977 Spring Meeting, Western States Section, Combustion Institute, Univ. of Washington, Seattle, Washington, April 18-19, 1977.

Blazowski, W.S., D.E. Walsh, and K.D. Mach, "Operating and Ambient Condition Influences on Aircraft Gas Turbine NO<sub>x</sub> Emissions," *J. Aircraft*, Vol. 12, No. 2, pp. 110-115, February 1975.

Boeck, W.L., "Meteorological Consequences of Atmospheric Krypton-85," *Science*, Vol. 193, No. 4249, pp. 195-198, July 16, 1976.

Borucki, W.J., D.S. Colburn, R.C. Whitten, L.A. Capone, M. Covert, *Model Analysis of the Ozone Depletion Due to the August 1972 Solar Proton Event*, paper presented at AGU Meeting, Miami Beach, Florida, April 1978.

Bradley, R.S., and J. England, "Volcanic Dust Influence on Glacier Mass Balance at High Latitudes," *Nature*, Vol. 271, pp. 736-738, February 23, 1978.

Brasseur, G., "Un Modele Bidimensionnel du Comportement de l'Ozone dans la Stratosphere," *Planet Space Sci.*, Vol. 26, pp. 139-159, Pergamon Press, 1978.

Brewer, A.W., "Evidence for a World Circulation Provided by the Measurements of Helium and Water Vapor Distribution in the Stratosphere," *Quart. J. Roy. Meteorol. Soc.*, Vol. 75, pp. 351-363, 1949.

Broderick, A.J., "Stratospheric Effects from Aviation," *J. Aircraft*, Vol. 15, No. 10, pp. 643-653, October 1978.

Bryson, R., and J. Few, "Comparison of Turbine Engine Combustor Exhaust Emissions Measurements Using Three Gas Sampling Probe Designs," AEDS TR-78-7 (in press), 1978.

Budkyo, M.I., "On Present-Day Climatic Changes," *Tellus*, Vol. 29, pp. 193-204, 1977.

Budkyo, M.I., and I.L. Karol, "Review of the Climatic Impact Assessment Program's Research," (Translated for HAPP, Department of Transportation-FAA), Moscow *Meteorologiya I Gidrologiya* in Russian No. 9, pp. 103-111, 1976.

Burrows, J.D., et al., "Laboratory Studies of the Reactions of Hydroperoxy Radicals ( $\text{HO}_2$ ) Having Stratospheric Importance," presented at the World Meteorological Organization Symposium on the Geophysical Aspects and Consequences of Changes in the Composition of the Stratosphere, Toronto, Canada, p. 177, June 26-30, 1978.

Burrows, J.D., G.W. Harris, B.A. Thrush, "Rates of Reaction of  $\text{HO}_2$  with HO and O Studied by Laser Magnetic Resonance," *Nature*, Vol. 267, pp. 233-234, 1977.

Callis, L.B., J.E. Nealy, "Solar UV Variability and Its Effect on Stratospheric Thermal Structure and Trace Constituents," *Geophys. Res. Lett.*, Vol. 5, No. 4, April 1978.

Chang, J.S., "Uncertainties in the Validation of Parameterized Transport in 1-D Models of the Stratosphere," *Proceedings, Fourth Conference on CIAP*, pp. 175-182, February 1975.

Chang, J.S., D.J. Wuebbles, R. Tarp, *Fully Diurnal Averaged Model of the Stratosphere*, presented at IAGA/IAMAP Joint Session, Seattle, Washington, August 1977.

Chang, J.S., W.H. Dwyer, and D.J. Wuebbles, "The Atmospheric Nuclear Tests of the 50's and 60's: A Possible Test of Ozone Depletion Theories," (prepared for submission to *J. Geophys. Res.*) March 1978.

CIAP Monograph 1, *The Natural Stratosphere of 1974*, Department of Transportation, Climatic Impact Assessment Program, DOT-TST-75-51, final report, September 1975.

CIAP Monograph 2, *Propulsion Effluents in the Stratosphere*, Department of Transportation, Climatic Impact Assessment Program, DOT-TST-75-52, final report, September 1975.

COMESA, *The Report of the Committee on Meteorological Effects of Stratospheric Aircraft*, Parts 1 and 2, 1972-75.

Cox, R.A., R.G. Derwent, and A.J.L. Hutton, "Significance of Peroxynitric Acid in Atmospheric Chemistry of Nitrogen Oxides," *Nature*, Vol. 270, November 24, 1977.

Crutzen, P.J., "A Description of a One-Dimensional Photochemical Steady-State Model," *Meteorol. Monogr.*, 1977 (in press).

Crutzen, P.J., "A Review of Upper Atmospheric Photochemistry," *Can. J. Chem.*, Vol. 52, No. 8, pp. 1569-1581, 1974.

Crutzen, P.J., "SSTs--A Threat to the Earth's Ozone Shield," *Ambio*, Vol. 1, pp. 41-51, 1972.

Crutzen, P.J., "Ozone Production Rates in an Oxygen-Hydrogen-Nitrogen Oxide Atmosphere," *J. Geophys. Res.*, Vol. 76, pp. 7311-7327, 1971.

Crutzen, P.J., "The Influence of Nitrogen Oxides on the Atmospheric Ozone Content," *R. Meteorol. Soc. Quart. J.*, Vol. 96, pp. 320-325, 1970.

Crutzen, P.J., and C.J. Howard, "The Effect of the HO<sub>2</sub> + NO Reaction Rate Constant on One-Dimensional Model Calculations of Stratospheric Ozone Perturbations," *PAGEOPH*, Vol. 116, Birkhäuser Verlag, Basel, pp. 497-510, 1978.

Crutzen, P.J., I.S.A. Isaksen, J.R. McAfee, "The Impact of the Chlorocarbon Industry in the Ozone Layer," *J. Geophys. Res.*, Vol. 83, No. C1, pp. 345-363, January 20, 1978.

Crutzen, P.J., I.S.A. Isaksen, G.C. Reid, "Solar Proton Events: Stratospheric Sources of Nitric Oxide," *Science*, Vol. 189, pp. 457-459, August 8, 1975.

Danielsen, E.F., and J.F. Louis, "Transport in the Stratosphere," from *The Upper Atmosphere and Magnetosphere (Studies in Geophysics)*, National Academy of Sciences, Washington, D.C., 1977.

Danielsen, E.F., and V.A. Mohnen, "Project Dust Storm Report Ozone Transport, In-Situ Measurements and Meteorological Analysis of Tropopause Folding," *J. Geophys. Res.*, Vol. 82, No. 37, pp. 5867-5877, December 20, 1977.

Davidson, D.L., and A.F. Domal, *Emission Measurements of a J93 Turbojet Engine*, Arnold Engineering Development Center, Tennessee, FAA-RD-73-66, September 1973.

Department of Transportation, FAA, *Aviation Futures to the Year 2000*, February 1977.

Diehl, L.A., G.M. Reck, D.J. Marek, and A.J. Szahniszlo, "XIV Stratospheric Cruise Emission Reduction Program," *Aircraft Engine Emissions*, a conference held at Lewis Research Center, Cleveland, Ohio, May 18-19, 1977, NASA Conference Publication 2021, pp. 357-391.

Duewer, W.H., D.J. Wuebbles, H.W. Ellsaesser, and J.S. Chang, "NO<sub>x</sub> Catalytic Ozone Destruction: Sensitivity to Rate Coefficients," *J. Geophys. Res.*, Vol. 82, No. 6, pp. 935-942, February 20, 1977.

Duewer, W.H., D.J. Wuebbles, H.W. Ellsaesser, and J.S. Chang, "Reply," *J. Geophys. Res.*, Vol. 82, No. 18, pp. 2599-2605, June 20, 1977a.

Ehhalt, D.L., L.E. Heidt, R.H. Lueb, and N. Roper, "Vertical Profiles of CH<sub>4</sub>, H<sub>2</sub>, CO, N<sub>2</sub>O, and CO<sub>2</sub> in the Stratosphere," *Proceedings, Third Conference on CIAP*, pp. 153-160, February 1974.

Ellsaesser, H.W., "Water Budget of the Stratosphere," *Proceedings, Third Conference on CIAP*, pp. 273-283, February 1974.

Farlow, N.H., D.M. Hayes, and H.Y. Lem, "Stratospheric Aerosols: Undissolved Granules and Physical State," *J. Geophys. Res.*, Vol. 82, No. 31, pp. 4921-4929, October 20, 1977.

Few, J.D., *Optical Measurements of NO and NO<sub>2</sub> in the Exhaust of an F-101-GE-100 Engine at Simulated Altitudes*, Arnold Engineering Development Center, Tennessee, AEDC-TR-77-5, December 1977.

Few, J.D., R.J. Bryson, and W.K. McGregor, *Evaluation of Probe Sampling vs. Optical In-Situ Measurements of Nitric Oxide Concentrations in a Jet Engine Combustor Exhaust*, Arnold Engineering Development Center, Tennessee, AEDC-TR-76-180, January 1977.

Few, J.D., W.K. McGregor, and H.N. Glassman, *Comparison of UV Absorption Measurements with Probe-Sampling Measurements of Nitric Oxide Concentration in a Jet Engine Combustor Exhaust*, Arnold Engineering Development Center, Tennessee, AEDC-TR-76-134, September 1976.

Foley, H.M. and M.A. Ruderman, "Stratospheric NO Production from Past Nuclear Explosions," *J. Geophys. Res.*, Vol. 78, pp. 4441-4450, 1973.

Forney, A.K., *Engine Exhaust Emission Levels*, presented at the AIAA 11th Aerospace Sciences Meeting, Washington, D.C., AIAA Paper No. 73-98, January 10-12, 1973.

Geddes, J.P. "World Commercial Air Transport Market to 1991," *Interavia*, pp. 987-990, October 1977.

Grobecker, A.J., S.C. Coroniti, and R.H. Cannon, Jr., *Report of Findings - The Effects of Stratospheric Pollution by Aircraft*, DOT-TST-75-50, prepared by Department of Transportation, CIAP, December 1974.

Gryvnak, David A., and Darrell E. Burch, *Monitoring NO and CO in Aircraft Jet Exhaust by a Gas-Filter Correlation Technique*, Aero-nutronic Ford Corp., Newport Beach, California, AFAPL-TR-75-101, January 1976. Also AIAA Paper 76-110, January 26-28, 1976.

Hamill, P., O.B. Toon, and C.S. Kiang, "Microphysical Processes Affecting Stratospheric Aerosol Particles," *J. Atmos. Sci.*, Vol. 34, pp. 1104-1119, July 1977.

Harries, J.E., "The Distribution of Water Vapor in the Stratosphere," *Revs. Geophys. Space Phys.*, Vol. 14, No. 4, pp. 565-575, November 1976.

Harrison, H., "Stratospheric Water Vapor: Influence of High-Altitude Aircraft," *Science*, Vol. 170, pp. 734-736, 1970.

*Hearings, Civil Supersonic Aircraft Development (SST)*, before a Subcommittee of the Committee on Appropriations House of Representatives, 92nd Congress, First Session, John J. McFall, Chairman, 1971.

Heath, D.F., A.J. Krueger, and P.J. Crutzen, *Influence of a Solar Proton Event on Stratospheric Ozone*, Goddard Space Flight Center, Report X-912-76-712, June 1976.

Hidalgo, H. and P.J. Crutzen, "The Tropospheric and Stratospheric Composition Perturbed by NO<sub>x</sub> Emission of High Altitude Aircraft," *J. Geophys. Res.*, Vol. 82, No. 37, pp. 5833-5866, December 20, 1977.

Hidalgo, H., "Status of Representative Two-Dimensional Photo-chemical Models of the Stratosphere and Troposphere as of Mid-1978," IDA Paper P-1341, in press, 1978.

Hilsenrath, E., B. Guenther, and P. Dunn, "Water Vapor in the Lower Stratosphere Measured from Aircraft Flight," *J. Geophys. Res.*, Vol. 82, No. 34, pp. 5453-5458, November 20, 1977.

Howard, C.J., "Recent Developments in Atmospheric HO<sub>2</sub> Chemistry," presented at the World Meteorological Organization Symposium on the Geophysical Aspects and Consequences of Changes in the Composition of the Stratosphere, Toronto, Canada, p. 11, June 26-30, 1978.

Howard, C.J., and K.M. Evenson, "Kinetics of the Reaction of HO<sub>2</sub> with NO," *Geophys. Res. Lett.*, Vol. 4, No. 10, October 1977.

Hudson, R.D., ed., *Chlorofluoromethanes and the Stratosphere*, Goddard Space Flight Center, Greenbelt, Maryland, NASA Ref. Pub. 1010, 1977.

Hunt, B.G., "Photochemistry of Ozone in a Moist Atmosphere," *J. Geophys. Res.*, Vol. 71, p. 1385, 1966.

Hunten, D.M., "Estimates of Stratospheric Pollution by an Analytic Model," *Proc. Natl. Acad. Sci.*, Vol. 72, pp. 4711-4715, 1975.

Hunten, D.M., "Residence Times of Aerosols and Gases in the Stratosphere," *Geophys. Res. Lett.*, Vol. 2, No. 27, 1975a.

Jaffe, R.L., and S.R. Langhoff, "Theoretical Study of the Photodissociation of HOCl," *J. Chem. Phys.*, Vol. 68, No. 4, February 15, 1978.

Jesson, J.P., "Sources and Sinks for the Atmospheric Chlorine System," presented at the World Meteorological Organization Symposium on the Geophysical Aspects and Consequences of Changes in the Composition of the Stratosphere, Toronto, Canada, p. 177, June 26-30, 1978.

Jesson, J.P., L.C. Glasgow, D.L. Filkin, and C. Miller, "The Stratospheric Abundance of Peroxynitric Acid," *Geophys. Res. Lett.*, Vol. 4, No. 11, November 1977.

Johnston, H.S., "Reduction of Stratospheric Ozone by Nitrogen Oxide Catalysts from Supersonic Transport Exhaust," *Science*, Vol. 173, pp. 517-522, 1971.

Johnston, H.S., D. Kattenhorn, and G. Whitten, "Use of Excess Carbon-14 Data to Calibrate Models of Stratospheric Ozone Depletion by Supersonic Transports," *J. Geophys. Res.*, Vol. 81, No. 3, pp. 368-380, 1976.

Kerr, R.A., "CO<sub>2</sub> and Climate: Carbon Budget Still Unbalanced," *Science*, Vol. 197, p. 1352, September 30, 1977.

Krueger, A.J., D.F. Heath, and C.L. Mateer, "Variations in Stratospheric Ozone Field Inferred from Nimbus Satellite Observations," *Pure Appl. Geophys.*, Vol. 106, No. 108, pp. 1254-1263, 1973.

Kuhn, P.M., *Stratospheric and Upper Tropospheric Water Vapor Experiment from Interhemispheric Survey of Minor Upper Atmospheric Constituents During October-November 1976*, Lewis Research Center, NASA, Cleveland, Ohio, NASA TM X-73630, pp. 45-54, March 1977.



Kuhn, P.M. and L.P. Stearns, "Radiometric Observations of Atmospheric Water Vapor Injection by Thunderstorms," *J. Atmos. Sci.*, Vol. 30, pp. 507-509, 1973.

Kuznetsov, G.I., and K.S. Nigmatullina, "Optical Determination of the Nitrogen Dioxide Content in the Atmosphere," *Izvestiya, Atmospheric and Oceanic Physics*, Vol. 13, No. 8, 1977, UDC 551.510.41.

Lamb, H.H., "Climate: Present, Past, and Future," Vol. 1, *Fundamentals and Climate Now*, Methuen & Co., p. 613, 1972.

List, R.J., *Smithsonian Meteorological Tables*, published by the Smithsonian Institution, 1958.

Liu, S.C., T.M. Donahue, R.J. Cicerone, and W.L. Chameides, "Effect of Water Vapor on the Destruction of Ozone in the Stratosphere Perturbed by ClX or NO<sub>x</sub> Pollutants," *J. Geophys. Res.*, Vol. 81, No. 18, pp. 3111-3118, June 20, 1976.

Livingston, W.C., "Cooling of the Sun's Photosphere Coincident with Increased Sunspot Activity," *Nature*, Vol. 272, pp. 340-341, March 23, 1978.

Luther, F.M., Principal Investigator, *Second Annual Report of Lawrence Livermore Laboratory to the High-Altitude Pollution Program*, September 30, 1977.

Luther, F.M., and W.H. Duewer, "Effect of Changes in Stratospheric Water Vapor on Ozone Reduction Estimates," *J. Geophys. Res.*, Vol. 83, No. C5, pp. 2395-2402, May 20, 1978.

Lyon, T.F., *Development of Emissions Measurement Techniques for Afterburning Turbine Engines: Supplement 1--Engine Emissions Test Data*, General Electric Company, Cincinnati, Ohio, AFAPL-TR-75-52, Supplement 1, October 1975.

Lyon, T.F., W.C. Colley, M.J. Kenworthy, and D.W. Bahr, *Development of Emissions Measurement Techniques for Afterburning Turbine Engines*, General Electric Company, Cincinnati, Ohio, AFAPL-TR-75-52, October 1975.

Mahlman, J.D., "Some Fundamental Limitations of Simplified Transport Models as Implied by Results from a Three-Dimensional General Circulator/Tracer Model," *Proceedings, Fourth Conference on CIAP*, pp. 132-146, February 1975.

Mahlman, J.D., and W.J. Moxim, "Tracer Simulation Using a Global General Circulation Model: Results from a Mid-Latitude Instantaneous Source Experiment," Geophysical Fluid Dynamics Laboratory, NOAA, Princeton University, November 1977. To be published in *J. Atmos. Sci.*, 1978.

Manabe S. and R.T. Wetherald, "The Effects of Doubling the CO<sub>2</sub> Concentration on the Climate of a GCM," *J. Atmos. Sci.*, Vol. 32, p. 3, 1975.

Manabe, S., and R.T. Wetherald, "Thermal Equilibrium of the Atmosphere with a Given Distribution of Relative Humidity," *J. Atmos. Sci.*, Vol. 24, No. 3, pp. 241-259, May 1967.

Markson, R., "Solar Modulation of Atmospheric Electrification and Possible Implications for the Sun-Weather Relationship," *Nature*, Vol. 273, pp. 103-109, May 11, 1978.

Mason, A.S., and H.G. Ostlund, "Atmospheric HT and HTO 3. Vertical Transport of Water in the Stratosphere," *J. Geophys. Res.*, Vol. 81, No. 30, pp. 5349-5352, October 20, 1976.

Mass, C., and S.H. Schneider, "Statistical Evidence on the Influence of Sunspots and Volcanic Dust on Long-Term Temperature Records," *J. Atmos. Sci.*, Vol. 34, pp. 1995-2004, December 1977.

Matthews, R.P., R.F. Sawyer, and R.W. Schefer, "Interferences in Chemiluminescent Measurements of NO and NO<sub>2</sub> Emissions from Combustion Systems," *Environ. Sci. Technol.*, Vol. 11, No. 12, pp. 1092-1096, November 1977.

McClatchey, R.A., R.W. Fenn, J.E.A. Selby, F.E. Volz, and J.S. Garin, *Optical Properties of the Atmosphere*, Environmental Research Paper No. 411, Air Force Cambridge Research Laboratories (NTIS No. 0497) 1972. Cited by Ramanathan 1977.

McElroy, M.B., S.C. Wofsy, J.E. Penner, and J.C. McConnell, "Atmospheric Ozone: Possible Impact of Stratospheric Aviation," *J. Atmos. Sci.*, Vol. 31, No. 287, 1974.

McGregor, W.K., J.D. Few, and C.D. Litton, *Resonance Line Absorption Method for Determination of Nitric Oxide Concentration*, Arnold Engineering Development Center, Tennessee, AEDC-TR-73-182, December 1973.

Miles, M.K., and P.B. Gildersleeves, "Volcanic Dust and Changes in Northern Hemisphere Temperature," *Nature*, Vol. 271, pp. 735-736, February 23, 1978.

Mitchell, J.M., Jr., "Recent Secular Changes of Global Temperature," *Ann. N.Y. Acad. Sci.*, Vol. 95, pp. 235-250, 1961.

Myerson, A.L., "New Heterogeneous Mode of Nitric Oxide Reduction by an In-Situ Formed Carbon," *Environ. Sci. Technol.*, Vol. 12, No. 2, pp. 212-217, February 1978.

National Academy of Sciences, *Response to the Ozone Protection Sections of the Clean Air Act Amendments of 1977: An Interim Report*, Committee on the Impacts of Stratospheric Change, National Research Council, 1977.

National Academy of Sciences, *Halocarbons: Effects on Stratospheric Ozone*, Panel on Atmospheric Chemistry, National Research Council, 1976.

National Academy of Sciences, *Halocarbons Environmental Effects of Chlorofluoromethane Release*, Committee on Impacts of Stratospheric Change, National Research Council, 1976.

National Academy of Sciences, *Environmental Impact of Stratospheric Flight: Biological and Climatic Effects of Aircraft Emissions in the Stratosphere*, 1975.

Newell, R.E., "One-Dimensional Models: A Critical Comment and their Application to Carbon Monoxide," *J. Geophys. Res.*, Vol. 82, No. 9, pp. 1449-1450, March 20, 1977.

Nicolet, M., "Ozone and Hydrogen Reactions," *Ann. Geophys.*, Vol. 26, p. 531, 1970.

Noxon, J.F., "Tropospheric NO<sub>2</sub>, *Journal of Geophysical Research*, Vol. 83, No. C6, pp. 3051-3057, June 20, 1978.

Oliver, R.C., "On the Response of Hemispheric Mean Temperature to Stratospheric Dust: An Empirical Approach," *J. Appl. Meteorol.*, Vol. 15, No. 9, pp. 933-950, September 1976.

Oliver, R.C., et al., *Aircraft Emissions: Potential Effects on Ozone and Climate*, prepared for High Altitude Pollution Program, FAA-EQ-77-3, IDA Paper P-1207, March 1977.

Penndorf, R., *Critical Analysis of Field Measurement Data*, unpublished final report prepared for HAPP, U.S. Department of Transportation/FAA, Report No. FAA-EQ-, August 1977.

Pittock, A.B., "Climatology of the Vertical Distribution of Ozone Over Apsendale (38°S 145°E)," *Quart. J. Roy. Meteorol. Soc.*, Vol. 103, No. 438, pp. 575-584, October 1977.

Poppoff, I.G., R.C. Whitten, R.P. Turco, and L.A. Capone, *An Assessment of the Effect of Supersonic Aircraft Operations on the Stratospheric Ozone Content*, NASA Reference Publication 1026, September 1978.

Pozdena, R., *Forecasts of Aircraft Activity by Altitude, World Region and Aircraft Type*, Stanford Research Institute, FAA-AVP-76-18, November 1976.

Prasad, S.S., R.L. Jaffee, R.C. Whitten, and R.P. Turco, "Reservoirs of Atmospheric Chlorine: Prospects for HOCl Revisited," *Planet. Space Sci.*, Vol. 26 (in press), 1978.

Ramanathan, V., "1977 Interactions Between Ice-Albedo, Lapse-Rate and Cloud-Top Feedbacks: An Analysis of the Non-Linear Response of a Gem Climate Model," *J. Atmos. Sci.*, Vol. 34, pp. 1885-1897, December 1977.

Ramanathan, V., "Greenhouse Effect Due to Chlorofluorocarbons: Climatic Implications," *Science*, Vol. 190, pp. 50-52, 1975.

Roberts, P.B., and H.F. Butze, "XV Advanced Low-NO<sub>x</sub> Combustors for Supersonic High-Altitude Gas Turbines," *Aircraft Engine Emissions*, conference held at Lewis Research Center, Cleveland, Ohio, May 18-19, 1977, NASA Conference Publication 2021, pp. 393-415.

Robertson, D.J., R.H. Groth, D.G. Gardner, and A.G. Glastris, *JAPCA*, Vol. 27, pp. 779-780, August 1977.

Robinson, G.D., *Effluents of Energy Production: Particulates; Part 3 in Energy and Climate*, National Academy of Sciences, 1977.

G.D. Robinson, "Weather and Climate Forecasting as Problems in Hydrodynamics," *Monthly Weather Review*, Vol. 106, No. 4, pp. 448-457, April 1978.

Samuelson, G.S., and J.M. Harman III, "Chemical Transformations of Nitrogen Oxides while Sampling Combustion Products," *JAPCA*, Vol. 27, No. 7, pp. 648-655, July 1977.

Schmeltekopf, A.L., D.L. Albritton, P.J. Crutzen, P.D. Goldan, W.J. Harrop, W.R. Henderson, J.R. McAfee, M. McFarland, H.I. Schiff, T.L. Thompson, (NOAA), D.J. Hofmann, and N.T. Kjome (Univ. of Wyoming), "Stratospheric Nitrous Oxide Altitude Profiles at Various Latitudes," *J. Atmos. Sci.*, Vol. 34, pp. 729-736, 1977.

Schmeltekopf, A.L., E.E. Ferguson, P.D. Goldan, J.R. McAfee, "Stratospheric Measurements of N<sub>2</sub>O, F11 and F12," presented at the IAGA/IAMAP Joint Assembly, Seattle, Washington, August 22-September 3, 1977 (1977a).

Schneider, S.H. and C. Mass, "Volcanic Dust, Sunspots, and Temperature Trends," *Science*, Vol. 190, No. 4216, pp. 741-746, November 21, 1975.

Scott, C.J., *A Review of Olympus 593 Engine Emissions During High-Altitude Concorde Flights*, presented at the Second COMESA COVUS Symposium, Oxford, England, September 24-26, 1974.

Seery, D.J., and M.F. Zabielski, *Mass Spectrometer Study of NO Formation in Methane-Air Flames*, Paper 77-45. Presented at the 1977 Fall Meeting, Western States Section 1, Combustion Institute, Stanford, California, October 17-18, 1977.

Simonaitis, R., and J. Heicklen, *The Temperature Dependence of the Reactions of HO<sub>2</sub> with NO and NO<sub>2</sub>*, Pennsylvania State Ionospheric Research, Scientific Report 454, March 7, 1977.

Simonaitis, R., and J. Heicklen, "Reactions of HO<sub>2</sub> With NO and NO<sub>2</sub> and of OH With NO," *J. Phys. Chem.*, Vol. 80, pp. 1-7, 1976.

Stanford, J.L. "On the Nature of Persistent Stratospheric Clouds in the Antarctic," *Tellus*, Vol. 29, pp. 530-534, 1977.

Sugiyama, S., N. Arai, M. Hasatani, S. Kawamura, I. Kudou, and N. Matsuhiro, "Reducing Fuel NO<sub>x</sub> Emission: N<sub>2</sub> Formation From Fuel N," *Environ. Sci. Technol.*, Vol. 12, No. 2, pp. 175-180, February 1978.

Thrush, B.A., *Aspects of the Chemistry of Ozone Depletion*, University of Cambridge, Prepublication Draft, December 1977.

Tuck, A.F., "Numerical Model Studies of the Effect of Injected Nitrogen Oxides on Stratospheric Ozone," *Proc. R. Soc. Lond.*, Vol. 355, pp. 267-299, 1977.

Turco, R.P., P. Hamill, O.B. Toon, and R.C. Whitten, *A Model of the Stratospheric Aerosol. Atmospheric Aerosols: Their Optical Properties and Effects. A Topical Meeting on Atmospheric Aerosols*, Williamsburg, Virginia, NASA CP-2004, December 1976.

Turco, R.P., and R.C. Whitten, *The NASA Ames Research Center One- and Two-Dimensional Stratospheric Models, Part I: The One-Dimensional Model*, NASA Technical Paper 1002, September 1977.

Watson, R.T., "Rate Constants for Reactions of ClO<sub>x</sub> of Atmospheric Interest," *J. Phys. Chem. Ref. Data*, Vol. 6, No. 3, 1977.

Weinberg, A.M., "Trans-Science," *Nature*, Vol. 273, p. 93, May 11, 1978.

Widhopf, G., L. Glatt, R. Kramer, "A Two-Dimensional Time-Dependent Photochemical Model of the Atmosphere," final report, Aerospace Corporation, October 1976. See also "Results of a Phenomenological Two-Dimensional Time-Dependent Photochemical Model of the Atmosphere," *AIAA preprint 77-131*, 24-26 January 1977.

Widhopf, G.F., and L. Glatt, "Numerical Modeling of Atmospheric Pollution," presented at the Sixth International Conference on Numerical Methods in Fluid Dynamics held in Tbilisi, USSR, June 20-25, 1978 (to appear in Meeting Proceedings, Springer-Verlag).

Wofsy, S.C., "Temporal and Latitudinal Variations of Stratospheric Trace Bases: A Critical Comparison Between Theory and Experience," *J. Geophys. Res.*, Vol. 83, January 20, 1978.

Woodwell, G.M., "The Carbon Dioxide Question," *Scientific American*, Vol. 283, No. 1, pp. 34-43, 1978.

Wuebbles, D.J., *H<sub>2</sub>O Injections in the Stratosphere*, High Altitude Pollution Program, Quarterly Progress Report, Lawrence Livermore Laboratory, DOT-FA76WAI-653, December 15, 1977 to March 15, 1978.

Yung, Y.L., W.C. Wang, and A.A. Lacis, "Greenhouse Effect Due to Atmospheric Nitrous Oxide," *Geophys. Res. Lett.*, Vol. 3, No. 10, pp. 619-621, October 1976.

Zahniser, M.S., and C.J. Howard, "A Direct Measurement of the Temperature Dependence of the Rate Constant for the Reaction  $\text{HO}_2 + \text{O}_3 \rightarrow \text{OH} + 2 \text{O}_2$ ," presented at the World Meteorological Organization Meeting, Toronto, Canada, June 26-30, 1978.

APPENDIX A

AN ALTERNATIVE LOOK AT THE GENERAL ELECTRIC EMISSIONS DATA  
(Lyon et al., 1975; Lyon, 1975)

## APPENDIX A

### AN ALTERNATIVE LOOK AT THE GENERAL ELECTRIC EMISSIONS DATA (Lyon et al., 1975; Lyon, 1975)

#### A.1 BACKGROUND

As discussed in the main text, the issue of the appropriateness of probe sampling techniques (particularly under afterburning conditions) to determine  $\text{NO}_x$  in jet engine exhausts was raised by the work of Davidson and Domal (1973), who found, using in-situ spectroscopic techniques, that probe techniques may give severely low  $\text{NO}_x$  values. The question led to the referenced work by GE investigators who studied  $\text{NO}_x$  measurements by probe techniques over a wide range of conditions (military power to full afterburning) and from zero to about 24 nozzle diameters downstream. The J85 and J79 engines were used. The GE work did not employ spectroscopic techniques, but did sample combustion gases at high and low temperature conditions and with various degrees of dilution. GE concluded that the probe techniques, used properly, give emission index values independent of position downstream, and hence, implicitly, the probe techniques must be accurate.

The GE effort was broken into several phases. The first phase was exploratory. The second phase involved a great deal of data collection, but some difficulty with measuring instruments was noted, and analytical procedures were under development. The data did show a disconcerting tendency to give higher  $\text{NO}_x$  emission indices as gas samples were taken from cooler (more dilute) regions, but material balance questions were evident in many cases. Examples of these effects are shown in Table A-1.

A-3

PRECEDING PAGE BLANK-NOT FILMED



TABLE A-1. APPARENT NO<sub>x</sub> EMISSION INDICES vs. DOWNSTREAM POSITIONS  
J85-5, MILITARY POWER, PRELIMINARY TEST RESULTS

<u>Station, ft</u>	<u>Metered Fuel Flow, pps</u>	<u>Calculated Fuel Flow, pps</u>	<u>E.I. NO<sub>x</sub></u>
0	0.683	0.687	4.4
3.75	0.689	0.614	4.7
7.5	0.708	0.654	4.7
15.0	0.719	0.598	6.7
30.0	0.714	0.280	10.3

Source: Lyon et al., 1975 (p. 124)

Similar trends were noted at other conditions and for both engines, although the calculated fuel flow and metered fuel flows did not all behave in the fashion shown in this example.

The difficulty was ascribed to measurement errors, primarily in CO<sub>2</sub> content at large dilutions, and in some cases to background contaminant levels. A technique was thus developed in which measured NO<sub>x</sub> was plotted against measured CO<sub>2</sub> values, and emission indices deduced from the slopes. This technique was then used, together with improved instrumentation in Phase III. Phase II involved measurements at four stations. Phase III involved measurements only at the exhaust plane and about 24 nozzle diameters downstream. Results of Phase III work to be analyzed here are shown in Figs. A-1 to A-4; the corresponding detailed tabular data are given by Lyon (1975) (Tables 41, 45, 49, and 53 for military power and Tables 44, 48, 52, and 56 for maximum afterburning power). Tables A-2 and A-3 show the GE summarized results.

Figure A-4 represents an extreme case in which a severely polluted atmosphere is implied, with background NO<sub>x</sub>, hydrocarbon, and CO<sub>2</sub> contents of about 2, 5, and 10 ppmv, respectively. The plots indicate a negative hydrocarbon emission index; the entries are dashed in Table A-3.

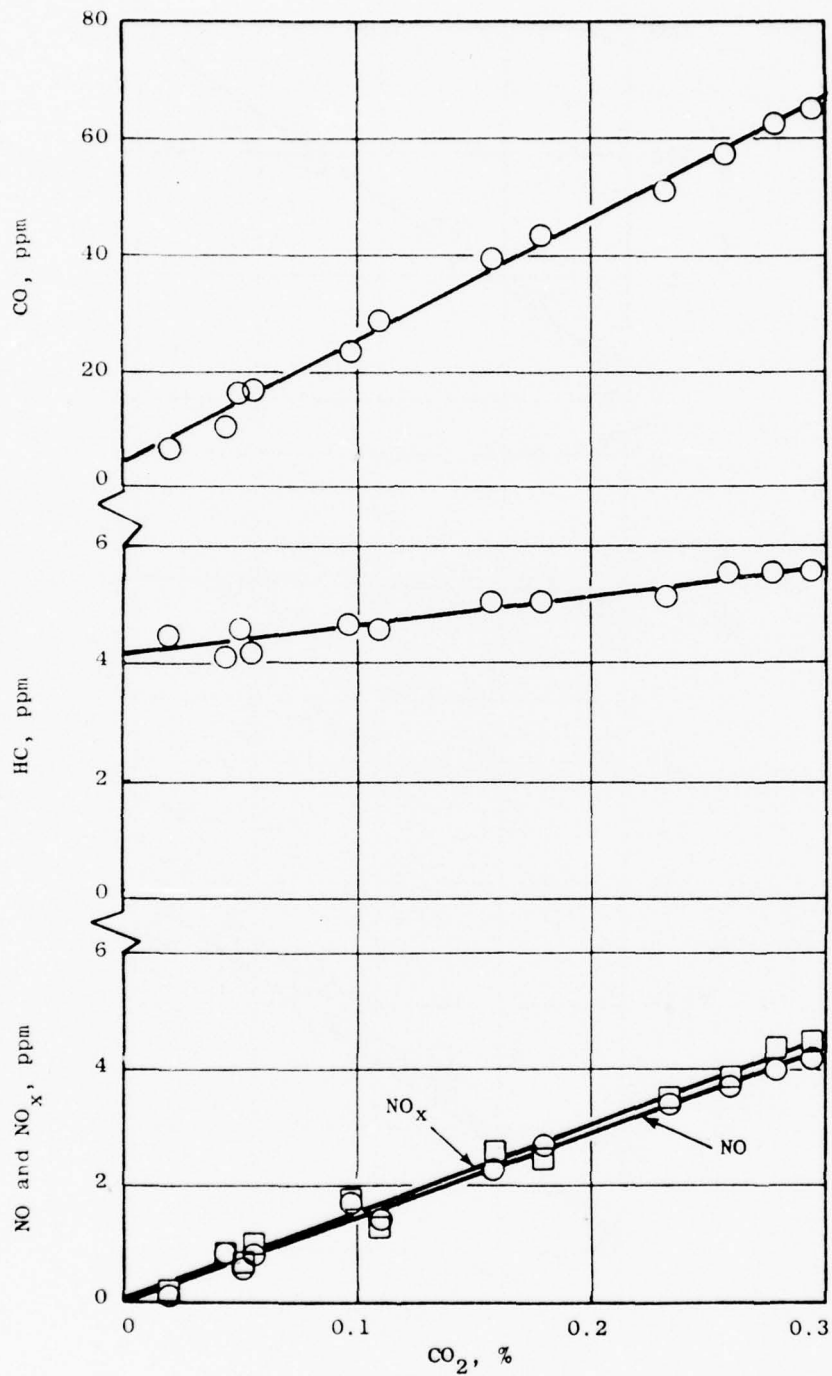

FIGURE A-1. Emissions concentrations vs. CO<sub>2</sub> for J85-5 engine, 30 feet aft of exhaust nozzle, military power. Final data by Far Plume Method.

Source: Lyon et al., 1975

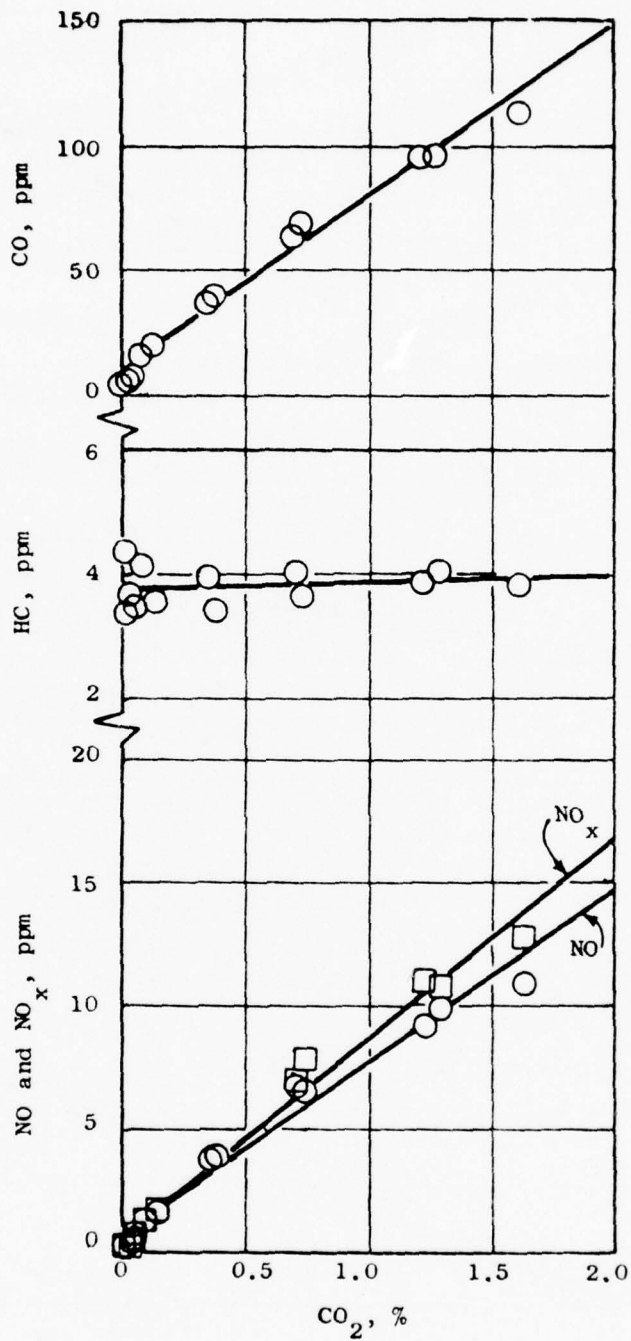

FIGURE A-2. Emissions concentrations vs. CO<sub>2</sub> for J85-5 engine, 30 feet aft of exhaust nozzle, at max. A/B power. Final data by Far Plume Method.

Source: Lyon et al., 1975

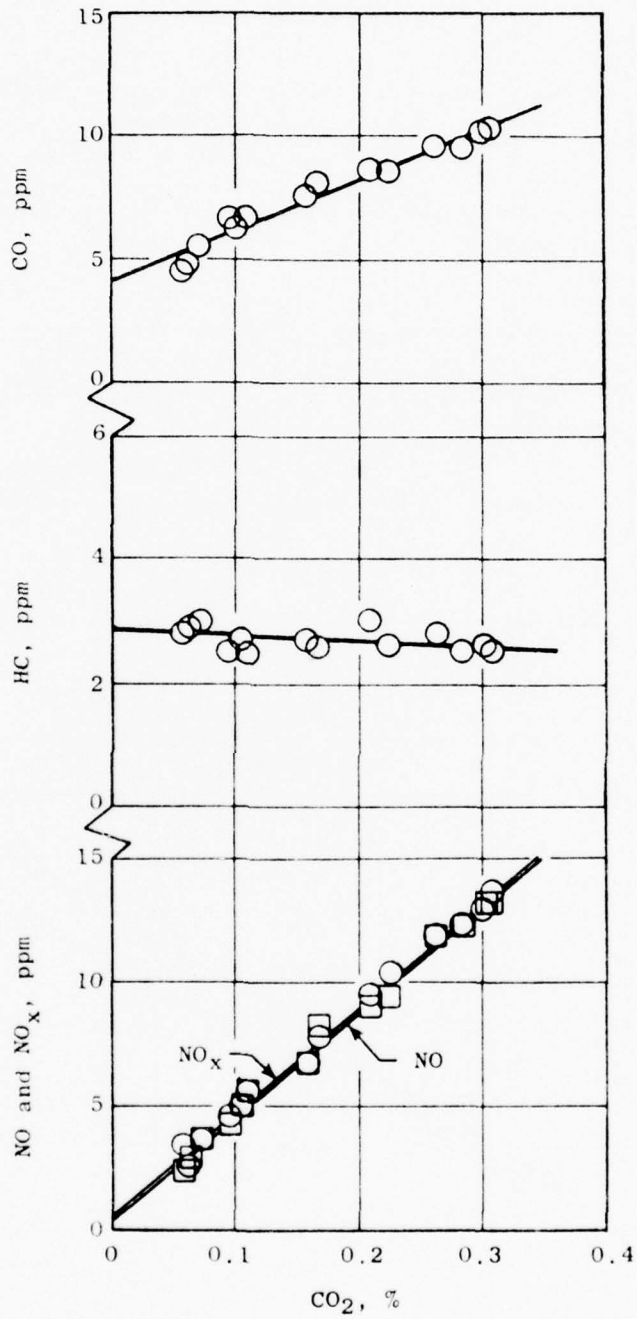

FIGURE A-3. Emissions concentrations vs. CO<sub>2</sub> for J79-15 engine, 60 feet aft of exhaust nozzle, at military power levels. Final data by Far Plume Method.

Source: Lyon et al., 1975

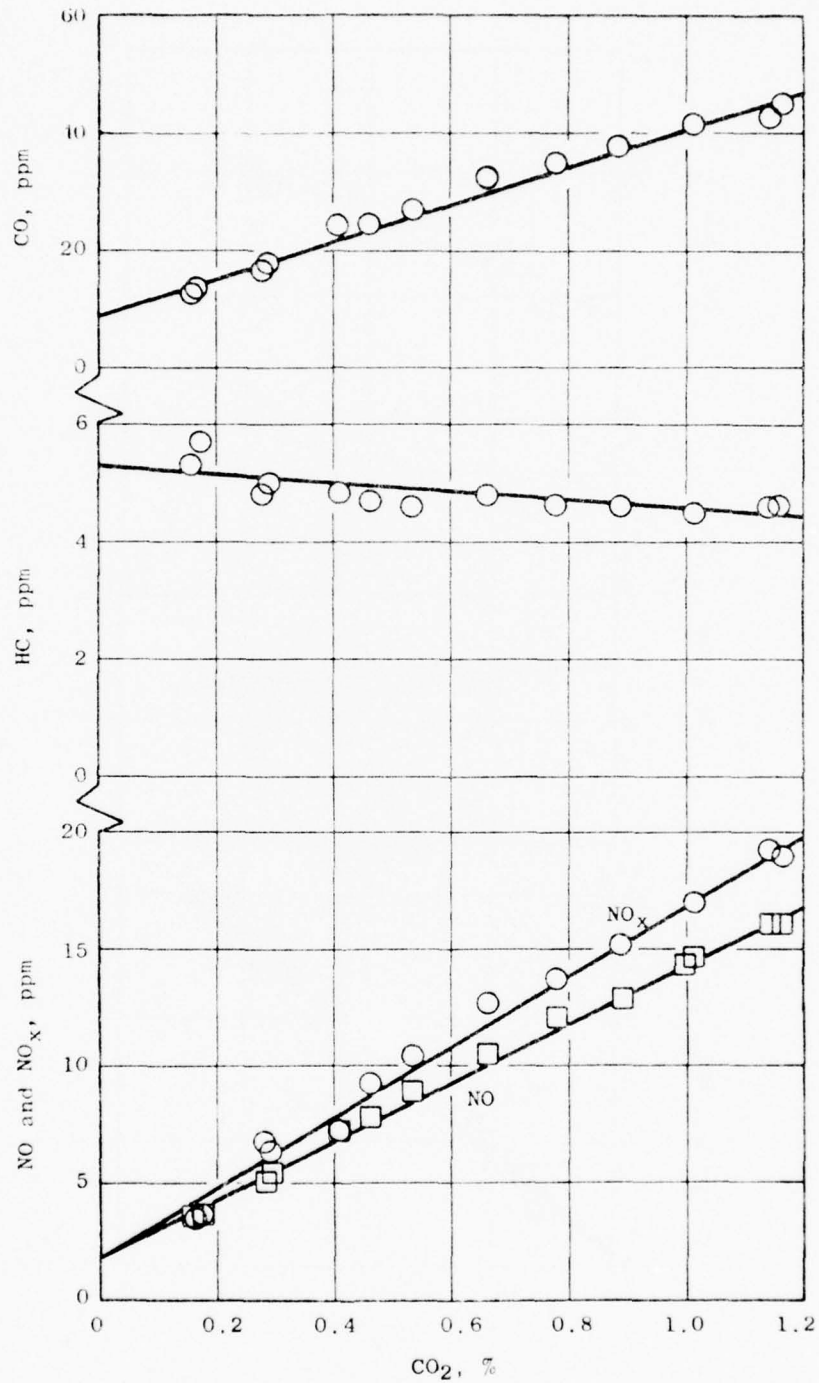

FIGURE A-4. Emissions concentrations vs. CO<sub>2</sub> for J79-15 engine, 60 feet aft of exhaust nozzle, at max. A/B power. Final data by Far Plume Method.

Source: Lyon et al., 1975

TABLE A-2. SUMMARY OF EMISSIONS DATA FROM FINAL J85-5 TESTS

Near Plume Procedure - Nozzle Exit (Integral Programs)

Power Level	Fuel Flow, pps		% Diff.	Emission Index lb/1000 lb fuel			Flow Rate, pps		
	Meas.	Calc.		CO	HC	NO <sub>x</sub>	CO	HC	NO <sub>x</sub>
Min	0.706	0.76	+ 7.6	33.9	0.3	4.6	.0258	.0003	.0035
Min A/B	1.167	1.16	- 0.6	95.9	60.3	2.8	.112	.070	.0033
Mid A/B	1.724	1.79	+ 3.8	56.3	7.2	2.8	.101	.0130	.0051
Max A/B	2.222	2.30	+ 3.5	144	1.5	2.6	.332	.0034	.0060

A-9

Far Plume Procedure - 30-Foot Station (ABE Program)

Power Level	Emission Index, lb/1000 lb fuel			Meas. Fuel Flow Rate, pps			Flow Rate, pps		
	CO	HC	NO <sub>x</sub>	CO	HC	NO <sub>x</sub>	CO	HC	NO <sub>x</sub>
Min	40.9	0.5	4.7	4.9	.731		.0299	.0004	.0034
Min A/B	10.9	53.3	1.5	2.4	1.171		.128	.0624	.0018
Mid A/B	25.3	0.4	2.5	3.3	1.722		.0436	.0007	.0043
Max. A/B	14.1	0	2.3	2.7	2.222		.0313	0	.0051

TABLE A-3. SUMMARY OF EMISSIONS DATA FROM FINAL J79-15 TESTS

Near Plume Procedure - Nozzle Exit (Integral Programs)

Power Level	Fuel Flow, pps		% Diff.	Emission Index lb/1000 lb fuel			Flow Rate, pps		
	Meas.	Calc.		CO	HC	NO <sub>x</sub>	CO	HC	NO <sub>x</sub>
Min	2.450	2.65	+ 8.1	4.0	0.05	12.0	.0106	.0001	.0318
Mid A/B	4.428	4.47	+ 0.9	35.4	11.9	7.1	.158	.0532	.0317
Max A/B	6.094	6.19	+ 1.6	76.8	65.8	5.2	.476	.407	.0322
Max A/B	8.328	8.50	+ 2.1	73.0	2.8	5.0	.621	.0239	.0421

Far Plume Procedure - 60-Foot Station (ABE Program)

Power Level	Emission Index, lb/1000 lb fuel			Meas. Fuel Flow Rate, pps			Flow Rate, pps		
	CO	HC	NO <sub>x</sub>	CO	HC	NO <sub>x</sub>	CO	HC	NO <sub>x</sub>
Min	4.1	- 0.09	13.8	2.535	-	.0350	.0104	-	.0350
Mid A/B	24.6	2.8	4.8	4.486	8.2	.0368	.1104	.0126	.0215
Max A/B	93.3	35.8	1.0	6.056	6.3	.0382	.565	.217	.0061
Max A/B	6.2	- 0.07	4.1	8.322	4.9	.0408	.0516	-	.0341

Note that the slopes of the lines in these figures are largely determined by the richer (and hotter) gas samples, the data at highest dilutions tending to have little weight. In order to see whether there may be information of interest in these high dilution data, an alternative procedure, which gives greatest emphasis to dilute gas samples, has been developed, and is described below.

## A.2 ALTERNATIVE PROCEDURE

In the approach that follows, no attempt is made to determine a mass-weighted emission index for the entire stream. Rather, the question is asked whether the various data on individual air samples imply higher emission indices as the parcels are cooled by mixing with ambient air.

Note that if fuel and exhaust gas compositions are known, the  $\text{NO}_x$  emission index and the air-to-fuel ratio for that sample can be calculated simply according to

$$\text{E.I. NO}_x = \frac{0.329 X_{\text{NO}_x}}{\Sigma}, \text{ gm NO}_x/\text{kg fuel}$$

$$\text{Air-to-fuel} = \frac{206}{\Sigma} - 1, \text{ gm/gm}$$

where

$$\Sigma = P_{\text{CO}_2} + \frac{X_{\text{CO}}}{10^4} + \frac{X_{\text{CH}}}{10^4}$$

and  $P_{\text{CO}_2}$  = percent  $\text{CO}_2$ , above background.  $X_{\text{NO}_x}$ ,  $X_{\text{CO}}$ ,  $X_{\text{CH}}$  are measured  $\text{NO}_x$ , CO, and unburned hydrocarbon contents, in ppmv (corrected, if necessary, for ambient levels).

At dilute conditions, where CO and HC contents are negligible,



$$\text{E.I. NO}_x = 0.329 \frac{X_{\text{NO}_x}}{P_{\text{CO}_2}}$$

or, more precisely,

$$\text{E.I. NO}_x = 0.329 \frac{\Delta X_{\text{NO}_x}}{\Delta P_{\text{CO}_2}}$$

where correction is made for background levels of  $\text{NO}_x$  and  $\text{CO}_2$ . This is the basis of the GE procedure. Unfortunately, however, background  $\text{NO}_x$  and  $\text{CO}_2$  levels were not measured (except indirectly by noting intercepts) so that high dilution results, which may contain the desired information are subject to severe uncertainties. To explore these effects, certain assumptions were necessary as follows:

1. The  $\text{CO}_2$  content was reduced by 0.032 percent, the known minimum level, or, in some cases, where the instrument showed a slightly smaller value (e.g., 0.02 percent) by the minimum value measured.
2. The ambient  $\text{NO}_x$  was assumed (a) to be zero, or (b) for the downstream cases, a value was read from a plot such as Fig. A-4, reading the  $\text{NO}_x$  value at 0.032 percent  $\text{CO}_2$ . (Ambient  $\text{NO}_x$  values on unpolluted air are  $< 1$  ppbv, which are negligible in this context.) Plots such as Fig. A-4 were not prepared by GE for the cases at the nozzle exits. The  $\text{NO}_x$  levels at this station are, however, still normally far above any normal background level.

Calculations using these procedures were made for military and maximum afterburning power for the J85 and J79 engines.

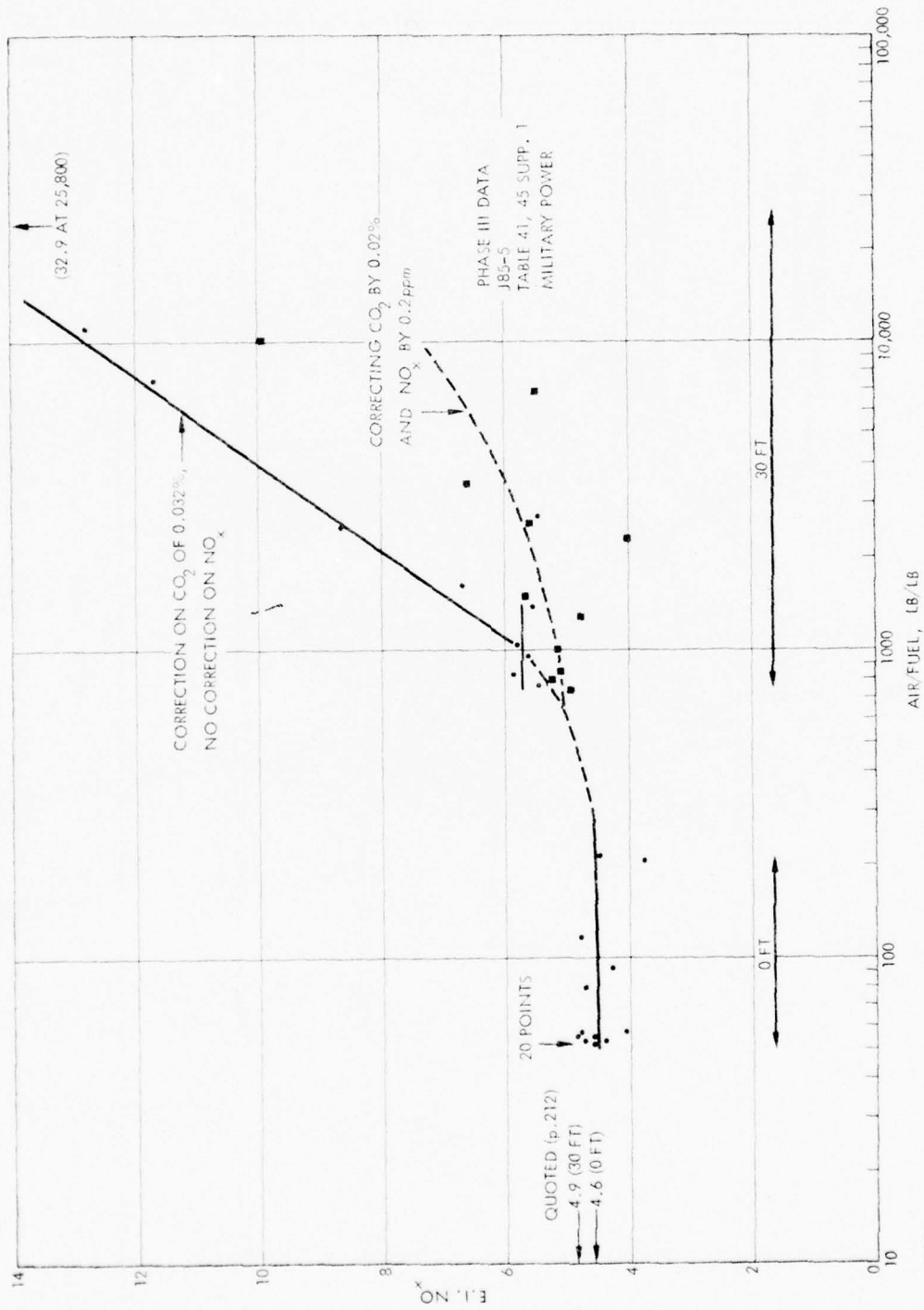

FIGURE A-5. Apparent NO<sub>x</sub> emission index as a function of dilution, J85-5 military power. Based on Lyon, 1975.

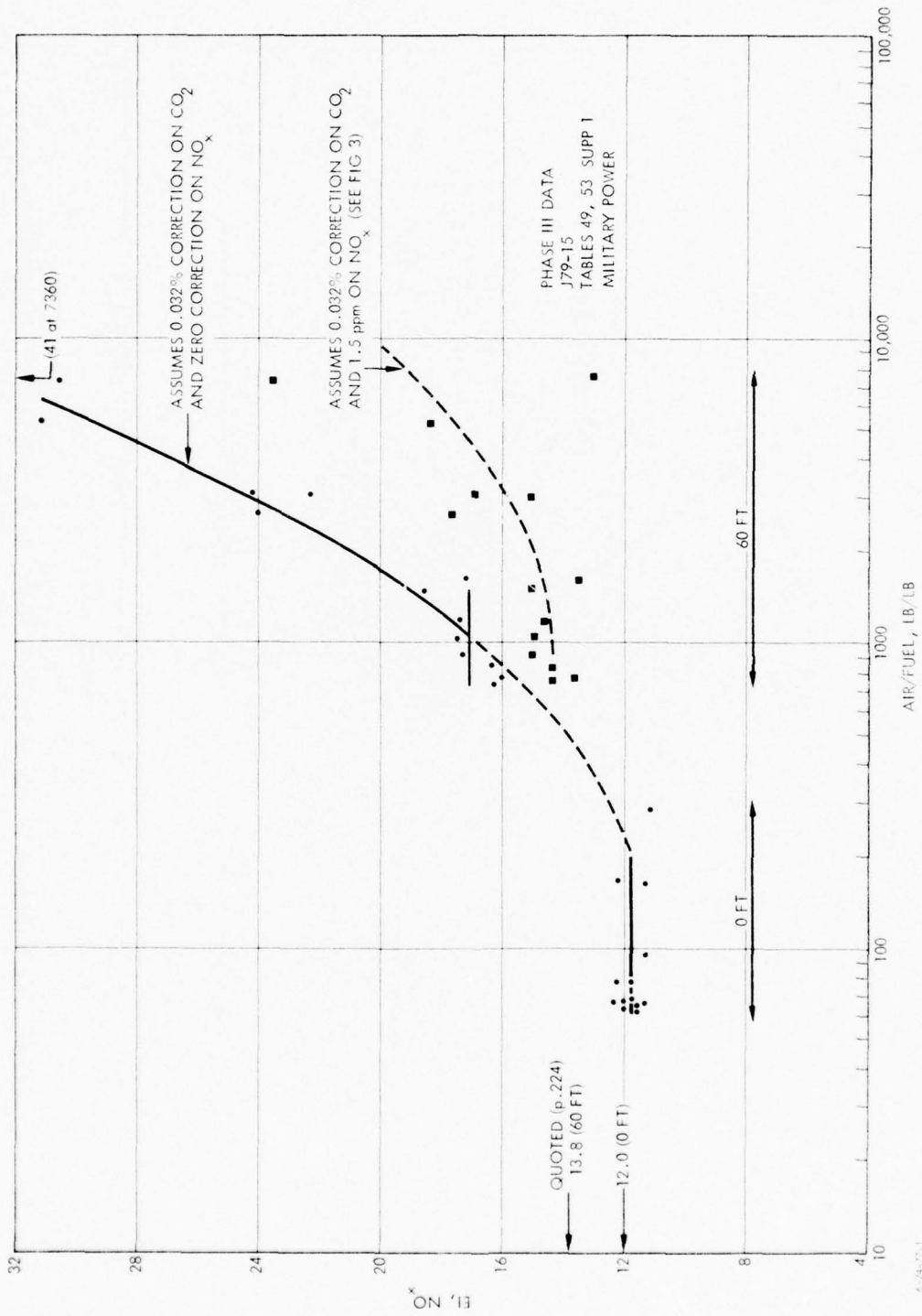
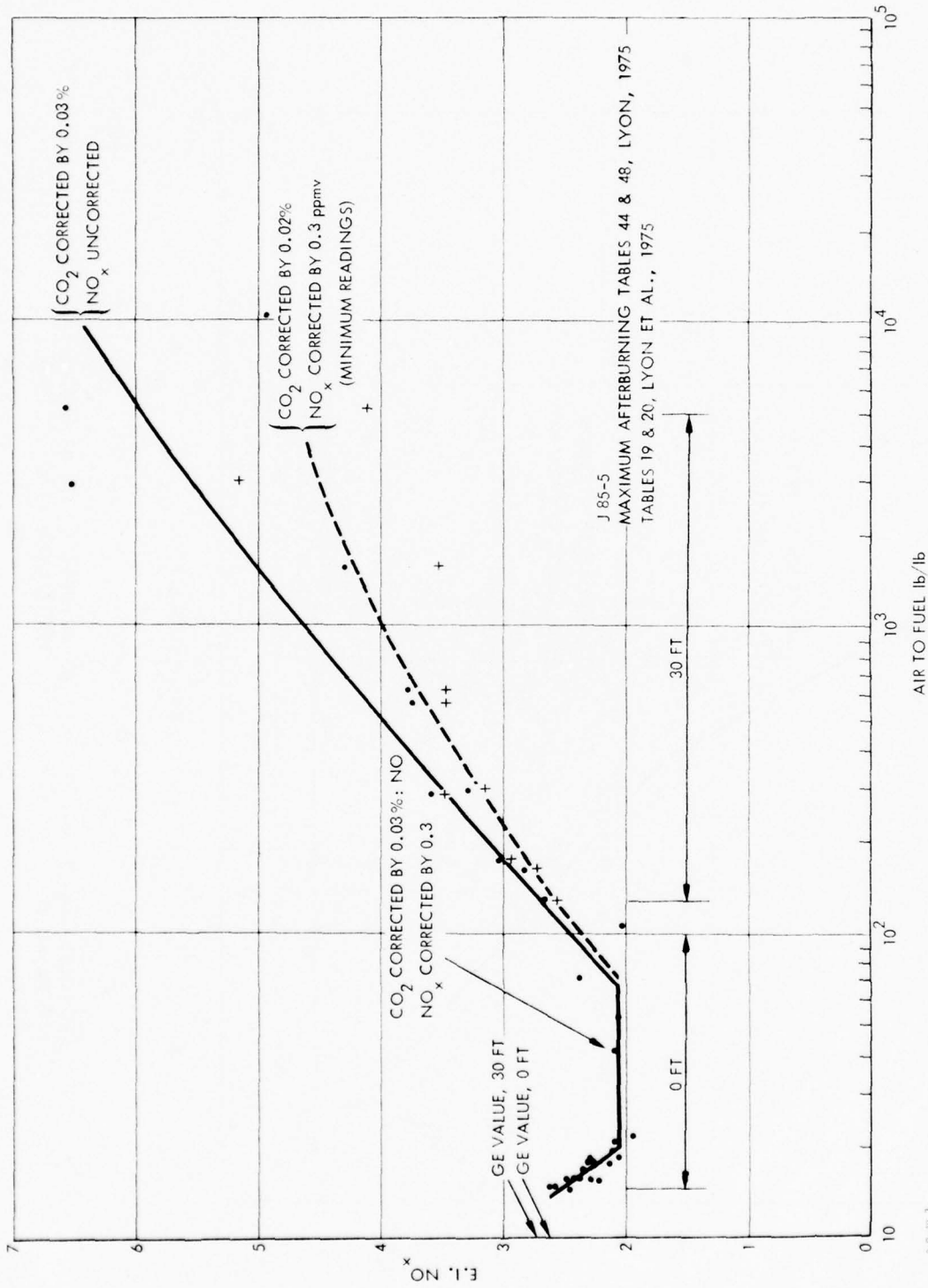

FIGURE A-6. Apparent NO<sub>x</sub> emission index as a function of dilution, J79-15 military power. Based on Lyon, 1975.



3-9-76-3

FIGURE A-7. Apparent NO<sub>x</sub> emission index as a function of dilution, J85-5, maximum afterburning. Based on Lyon, 1975; Lyon et al., 1975.

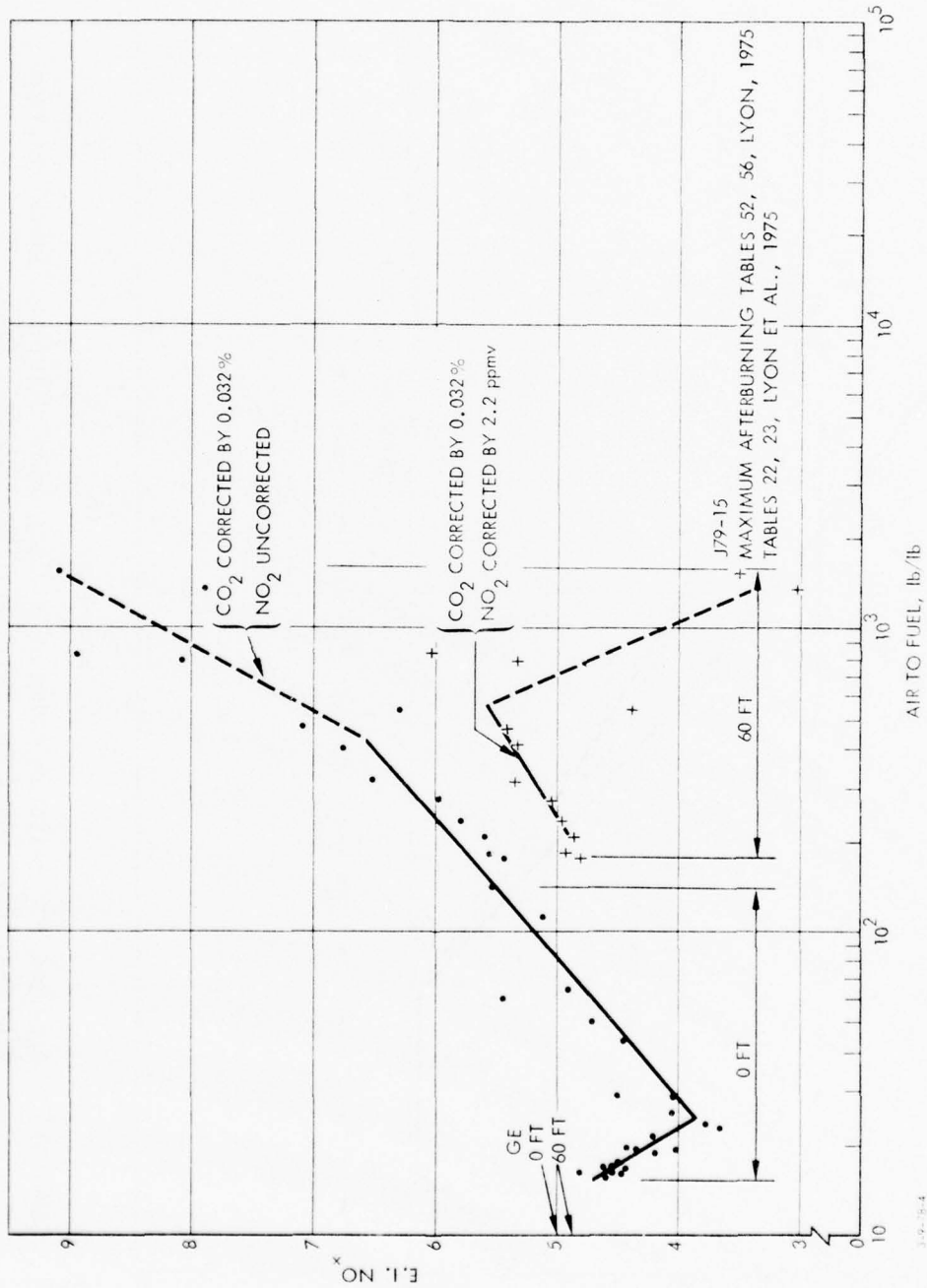

FIGURE A-8. Apparent NO<sub>x</sub> emission index as a function of dilution, J79-15, maximum afterburning. Based on Lyon, 1975; Lyon et al., 1975.

### A.3 RESULTS

Results for the four cases studied are shown in Figs. A-5 through A-8. Solid points are based on the assumption of negligible background  $\text{NO}_x$ ; crosses include a correction for background  $\text{NO}_x$ .

Note that this method of plotting permits incorporation of samples taken at any point in the plume.

### A.4 DISCUSSION

In all cases, the apparent  $\text{NO}_x$  emission index increases at high dilution. The effect takes place at much lower dilutions at maximum afterburning than at military power.

A correction for background  $\text{NO}_x$  has, as would be expected, a powerful effect on the apparent emission index at high dilutions. The correct value of background  $\text{NO}_x$  to use is unknown, and may have changed during the course of the run. Thus, there is great uncertainty in the derived value of the  $\text{NO}_x$  emission index.

In the afterburning cases, an interesting region exists in which the  $\text{NO}_x$  apparent emission index decreases with air-to-fuel ratio. This may imply destruction of  $\text{NO}_x$  with time by reactions with  $\text{CO}$ ,  $\text{H}_2$ , or hydrocarbons. After passing through a minimum, more  $\text{NO}_x$  may be generated by heating of excess air. Probe surface reactions may also enter.

For the military power cases, the rise in apparent emission index at air-to-fuel ratios greater than about 1000 to 1 is puzzling. The temperature rise at dilutions of this order is small: at 18,000 Btu/lb of fuel, the temperature rise at 1000 to 1 is about 72°F. Surface catalytic effects would seem improbable. The temperature maintained inside the line is higher (about 300°F) but still doesn't seem high enough to initiate surface catalytic reactions (such as the water-gas shift reaction,

followed by NO reduction). [It would be of interest, if it has not been done, to run known mixtures of NO (in moist air containing CO and hydrocarbons) through a probe tip and several hundred feet of line as used in the GE tests.]

The GE report, in general, shows slightly higher emission indices for the downstream location than for the nozzle exit. In the J79 maximum afterburning case, the value is lower, but the method of plotting shown in Fig. A-8 would not lead to the same conclusion.

In early work at AEDC [Davidson and Domal (1973)], the error in using probe techniques was greater with afterburning than without. It is debatable whether the results plotted here support this observation, due to uncertainties about the  $\text{NO}_x$  correction. (Note suppressed zeroes in Figs. A-6 and A-8. Note also that a correction of 2.2 ppmv in Fig. A-8 appears to be excessive.)

#### A.5 FINAL COMMENTS

Before any interpretation of  $\text{NO}_x$  emissions data can be accepted which shows large increases in emission index with dilution, the mechanisms involved would need to be established. The work reported by Benson and Samuelson (1977), e.g., might suggest  $\text{NO}_x$  reduction on the probe tip by unsaturated hydrocarbons. However, if this mechanism were operating, one would expect low  $\text{NO}_x$  emission indices in samples with large hydrocarbon contents. A brief perusal of the afterburning data (Table 52, e.g., Lyon, 1975) shows no such effect. Furthermore, the good linearity of  $\text{NO}_x$  vs.  $\text{CO}_2$  found in the GE plots, and the reasonable agreement (by their methods) between nozzle exits and 30 (J85) or 60 (J79) ft downstream stations, would seem to preclude any massive effect of probe tips, etc.

## REFERENCES, APPENDIX A

- Benson, R., and G.S. Samuelson, *Oxides of Nitrogen Transformation While Sampling Combustion Products Containing Carbon Monoxide, Hydrogen, and Hydrocarbons*, UCI Combustion Laboratory, Irvine, California, April 1977. Presented at the 1977 Spring Meeting, Western States Section, Combustion Institute, Univ. of Washington, Seattle, Washington, April 18-19, 1977.
- Davidson, D.L., and A.F. Domal, *Emission Measurements of a J93 Turbojet Engine*, Arnold Engineering Development Center, Tennessee, FAA-RD-73-66, September 1973.
- Lyon, T.F., *Development of Emissions Measurement Techniques for Afterburning Turbine Engines: Supplement 1--Engine Emissions Test Data*, General Electric Company, Cincinnati, Ohio, AFAPL-TR-75-52, Supplement 1, October 1975.
- Lyon, T.F., W.C. Colley, M.J. Kenworthy, and D.W. Bahr, *Development of Emissions Measurement Techniques for Afterburning Turbine Engines*, General Electric Company, Cincinnati, Ohio, AFAPL-TR-75-52, October 1975.



APPENDIX B

ON THE USE OF Zr-95 DATA FROM CHINESE ATMOSPHERIC  
THERMONUCLEAR EXPLOSIONS TO STUDY STRATOSPHERIC  
TRANSPORT IN A ONE-DIMENSIONAL PARAMETERIZATION

Ernest Bauer  
Robert C. Oliver  
Wasył Wasyłkiwskyj

## APPENDIX B

### ON THE USE OF Zr-95 DATA FROM CHINESE ATMOSPHERIC THERMONUCLEAR EXPLOSIONS TO STUDY STRATOSPHERIC TRANSPORT IN A ONE-DIMENSIONAL PARAMETERIZATION

#### B.1 INTRODUCTION

There has been considerable discussion [Grobeck et al. (1974), COMESA (1975), NAS (1975), NAS (1976), Oliver et al. (1977)\*] on the transport of materials injected into the lower stratosphere. Particular questions arise for the only currently existing SSTs, Concorde and Tu-144, which, in airline service, will inject most of their exhaust products in the 15-18 km altitude, 40-60°N latitude region. The one-dimensional parameterizations of this motion by different workers differ substantially.

From the standpoint of altitude and latitude of injection, the single set of data which are most directly comparable to stratospheric aircraft flight, in particular, the Concorde and Tu-144 SSTs, are the Zr-95 data from the five Chinese 3-Mt thermonuclear explosions that injected debris at 18 km altitude, 40°N, 90°E - see Telegadas (1974 and 1976). Here we examine the integrated stratospheric burden of the radioactive isotope Zirconium-95 (Zr-95; 65 day half-life) in terms of a

---

\* We should like to thank H.S. Johnston, D.M. Hunten, L. Machta, J.D. Mahlman, and K. Telegadas for helpful comments. The present work supersedes that reported in Appendix C of Bauer et al. (1977), which was based entirely on Model I (see Section B.3.1).

one-dimensional model which uses an effective mean eddy diffusivity  $\bar{K}$  (assumed to be constant above the tropopause) and an effective mean tropopause height  $z_0$  (which characterizes an effective height of injection above the local tropopause) as parameters to characterize atmospheric transport of precipitation-scavengeable materials.

## B.2 EXPERIMENTAL DATA

The U.S. ERDA (now DOE) "Airstream" program has involved sampling radioactive debris from aircraft flying at altitudes of 15 to 20 km along a flight path following generally along the West Coast of North and South America, from 72°N down to 50°S (more recently to 10°S only). These flights, at regular intervals of 4-6 months, are supplemented by occasional balloon probes which are flown mainly from San Angelo, Texas (32°N, 101°W) and which go to higher altitudes (27-35 km).

The Chinese nuclear explosions are conducted at Lop Nor (40°N, 90°E), which is roughly at the opposite meridian of longitude to the Airstream corridor; in general, East-West transport is considered to be fast compared to North-South transport, so that the Airstream profiles of radioactive debris should provide an effective zonal average profile of a tracer of atmospheric motions some weeks after the detonation. This assumption, made by Telegadas in deriving an estimate of the vertical, zonal averaged distribution of radioactivity with height, introduces some uncertainty into the data, especially at early times.\*

---

\* Thus, J.F. Louis (private communication, May 1976) who analyzed the 1967-1970 data with a two-dimensional model, treated the effective latitude of injection of the 1967 debris as 55°N rather than 40°N; evidently, the cloud from that detonation was caught in the Central Asian summer high-pressure cell and thus took a relatively long time before it was zonally spread.

Our primary concern in this work is with the rate of removal of radioactive debris from the lowest stratosphere on a global basis, although the height distribution of radioactivity in the stratosphere is of some interest.

Among other parameters (such as altitude and season), this removal rate will vary with the latitude of injection, so that the analysis that follows applies specifically only to the latitude under study; i.e.,  $40^\circ$  or, generally, mid-latitudes.

The data are described in terms of altitude/latitude profiles presented every 3 months in terms of a stratospheric burden of the isotope Zr-95, decay-corrected to the time of detonation. The integrated stratospheric burden of Zr-95 for the various Chinese 3-Mt thermonuclear explosions computed by Telegadas (1974, 1976) are shown in Fig. B-1. The numerical data from which Fig. B-1 was prepared are the basic experimental data analyzed here. Note that for a summer injection there is no significant decrease in stratospheric burden until midwinter, while with a winter injection of tracer, the stratospheric burden decreases steadily.

Figure B-2 shows the vertical Zr-95 activity distribution observed after the various Chinese nuclear tests. While the data are subject to major uncertainties because the Airstream sampling took place so far from the latitude of injection and often quite a long time after the actual injection, all the data suggest an injection height of the debris in the 17-19 km altitude range. The low value observed some 16 weeks after the October 1970 test is evidently due to large-scale cloud motion at some time well after the injection (cf. the distribution estimated one week after that same test).

In a one-dimensional model, one crucial parameter for a quantitative interpretation of transport out of the stratosphere is  $(z_1 - z_0)$ , the height of injection above the local tropopause. Inspection of Fig. B-2 shows that the present

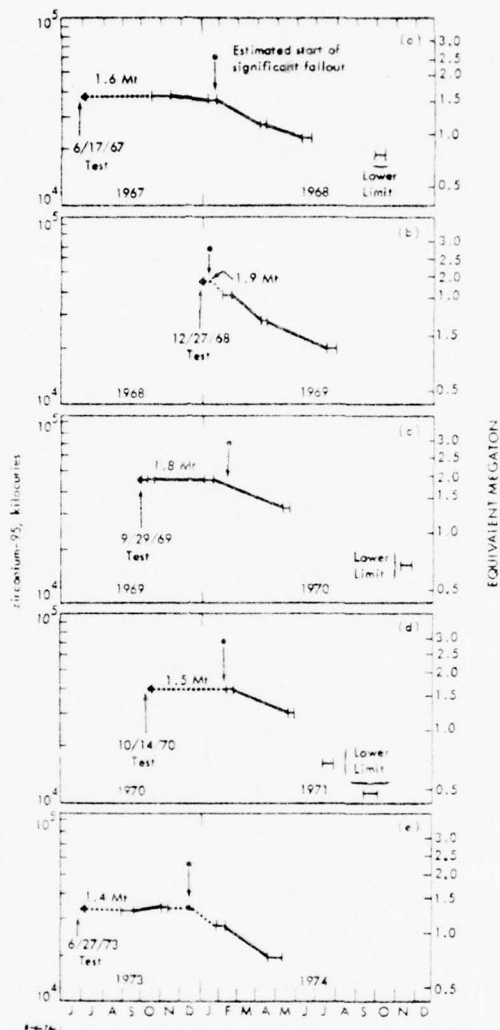

FIGURE B-1. Stratospheric Zr-95 burden (decay-corrected) following the Chinese nuclear tests. Observed burdens are indicated by the short horizontal lines.

Source: Telegadas, 1974, 1976

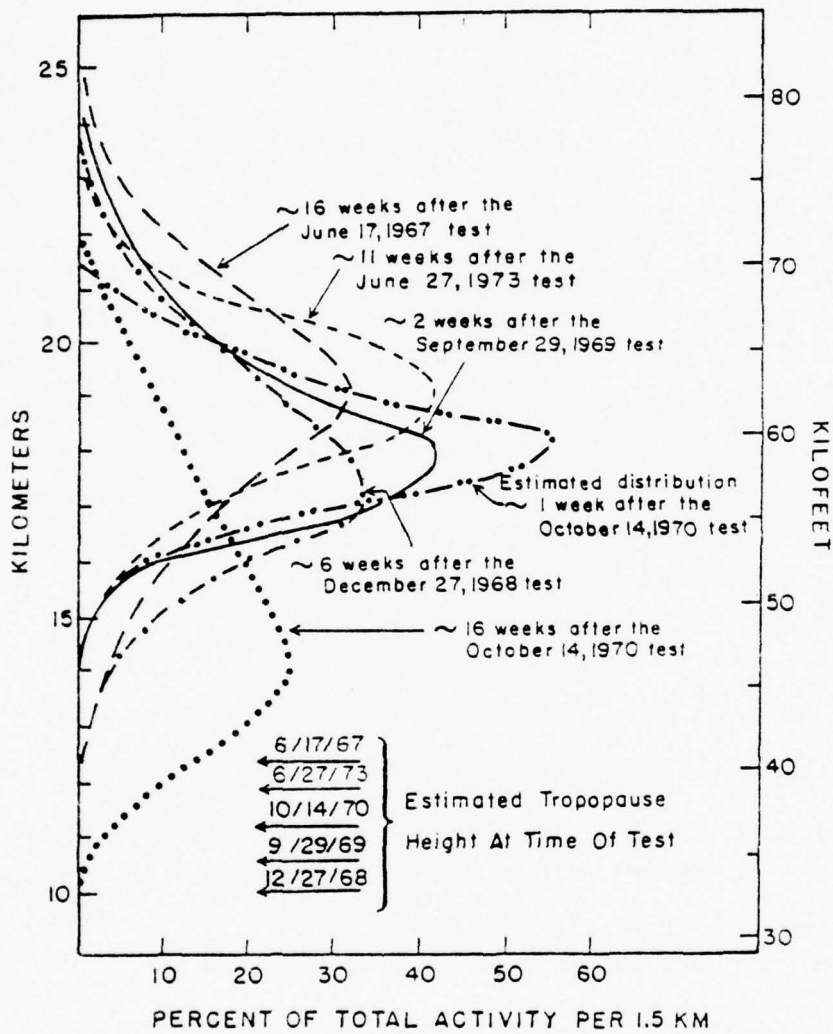

FIGURE B-2. Observed vertical Zr-95 activity distribution for five high yield Chinese nuclear tests.

Source: Telegadas, 1977

results are consistent with injection heights  $z_1$  of 17-19 km and with local tropopause heights  $z_0$  of 10-12.5 km. We describe the data in terms of a mean injection height  $z_1 = 18$  km and a mean tropopause height  $z_0 = 11$  km, corresponding to a net injection height  $(z_1 - z_0) = 7$  km above the local tropopause. [The tropopause height over Lop Nor ( $40^\circ\text{N}$ ,  $90^\circ\text{E}$ ) is highly variable, ranging from 10 km in winter up to 14-15 km in summer--see, e.g., Crutcher and Davies (1969).]

As an extreme in variability of the effective stratospheric injection height, we also consider  $z_0 = 14$  km which gives  $(z_1 - z_0) = 4$  km. The quantity  $(z_1 - z_0)$  will tend to be preserved in North-South transport since--while the local tropopause height changes significantly with latitude--the lines of constant mixing ratio for stratospheric injectants tend to remain parallel to the local tropopause, suggesting North-South transport parallel to the sloping tropopause [e.g., NAS (1975), p. 146; Machta and Telegadas (1973).]

### B.3 ANALYSIS OF THE DATA

#### B.3.1 Mathematical Formulism

For a chemically inert tracer of mixing ratio  $f(z,t)$  which is injected at time  $t = 0$  at some altitude  $z = z_1$  in the stratosphere, the transport equation may be written in terms of an effective eddy diffusion coefficient  $K(z)$  as

$$(\partial/\partial z)[n(z)K(z)\partial f/\partial z] = n(z) \partial f/\partial t . \quad (\text{B.1})$$

We treat the stratosphere as a region of constant and relatively small eddy diffusivity coefficient  $K$ , characterized by a tropopause at height  $z_0$ , below which transport is very much faster; the eddy diffusivity profile is taken as

$$K(z) = \begin{cases} K, \text{ constant, in the stratosphere; i.e., for } z > z_0 \\ K_t, \text{ constant, in the troposphere; i.e., for } z < z_0 \end{cases} \quad (\text{B.2})$$

where, typically,  $K_t \gtrsim 10$  K. This simple K-profile was used by Machta (1974) and by Crutzen (1974); it is used here because it permits transport out of the lowest stratosphere to be described in terms of only two parameters, namely  $K$  and  $z_0$ . (The value of  $K_t$  is typically not critical, as long as it is sufficiently greater than  $K$ .)

Most current models for  $K(z)$  show a monotonic increase with height above some minimum in the 10- to 20-km altitude range that is associated with the tropopause; Lindzen (1971) points out that this is a general characteristic associated with the decrease in density with increasing height. The present model does not show this increase in  $K$  at higher altitudes. However, any model satisfying Lindzen's criterion requires at least three parameters in the region of interest here [perhaps  $z_0$ , the lowest value of  $K$  above  $z_0$ , and the slope  $dK/dz$  or  $d(\log K)/dz$  above  $z_0$ ], and we prefer to analyze the Zr-95 data in terms of this simplest possible model before going to the additional complexity of a three-parameter model (which we plan to do in future work).

We also assume an isothermal stratosphere, so that in the region of interest

$$n(z) = n_0 e^{-(z-z_0)/H}, \quad (\text{B.3})$$

where  $n(z)$  = total particle number density at height  $z$ ,  $n_0 = n(z_0)$ , and the "scale height"  $H = kT/Mg$  is taken as 6.3 km (corresponding to  $T = 216$  K). In the region from 10 km to 20 km, which is of direct interest here, the assumption of constant temperature is quite well satisfied.



With the assumption of Eq. (B.3), the differential equation (B.1) becomes

$$(\partial/\partial z)\{K(z)\partial f/\partial z\} - \{K(z)/H\}\partial f/\partial z = \partial f/\partial t \quad . \quad (B.4)$$

Clearly, this equation simplifies somewhat further with the assumption of Eq. (B.2) for the eddy diffusivity profile,  $K(z)$ .

We initially ignore sedimentation of the aerosols carrying the Zr-95 tracer (postponing discussion to Section B.3.3 below), and now we wish to solve the diffusion Eq. (B.4) with the condition (B.2) for  $K(z)$ , for the following initial condition

$$f(z,0) = q \delta (z - z_1) \quad . \quad (B.5)$$

which corresponds to instantaneous point injection at height  $z_1$ ; the initial injection is not precisely a delta-function injection, so there is a slight time correction, as discussed in Section B.3.2.

Main emphasis is clearly on the stratosphere; in the troposphere; i.e., for  $z < z_0$ , we have made three different approximations, of successively increasing accuracy and complexity, namely,

- "Infinite Model" I: We solve the transport equation (B.1) for constant  $K$  (equal to the stratospheric value) for all  $z$ . This is a very simple model, but does not describe the situation in the troposphere or the lower boundary at all accurately.
- "Semi-infinite Model" S: Once again, we solve the transport equation (B.1) for constant  $K$  in both the stratosphere and the troposphere, but now we assume an absorbing surface at some height  $z_2$  (which may be taken as on the ground, at the tropopause, or at some intermediate altitude, possibly corresponding to the altitude of rain-out).

- "Two-step Model" T: We assume different rates of transport in the stratosphere and troposphere [i.e.,  $K_t \neq K$  in Eq. (B.2)] and zero mixing ratio at the ground.

The solution of Eq. (B.1) with the initial condition (B.5) for the infinite model I can be shown to be--see, e.g., Martin (1976)--

$$f_I(z,t) = q(4\pi Kt)^{-1/2} \exp \left\{ -(Kt/4) \left[ (1/H) - (z-z_1)/Kt \right]^2 \right\}. \quad (B.6)$$

With the more satisfactory treatment of the lower boundary by model S, it can be shown [Feller (1968), Martin (1976)] that the solution for  $z > z_2$  is

$$f_S(z,t) = f_I(z,t) \{1 - \exp [-(z-z_2)(z_1-z_2)/Kt]\}. \quad (B.7)$$

For the "two-step" model T, there is an additional requirement to matching stratospheric and tropospheric solutions at the tropopause,  $z = z_0$ . It is evident that  $f(z,t)$  must be continuous at the tropopause, and further, since there is no source or sink at the tropopause, the net flux transported across  $z = z_0$  must be continuous. By integrating Eq. (B.1) with respect to  $z$ , this condition is seen to be

$$n(z) K(z) \partial f / \partial z = \text{continuous at } z = z_0, \quad (B.8a)$$

or

$$K^{(\text{Strat.})} \partial f^{(\text{Strat.})} / \partial z \Big|_{z=z_0} = K^{(\text{Trop.})} \partial f^{(\text{Trop.})} / \partial z \Big|_{z=z_0}. \quad (B.8b)$$

It may be shown that the solution of the two-step model characterized by Eq. (B.4), with the initial condition of Eq. (B.5), with the matching condition (B.8b) at the tropopause  $z_0$ , and with a sink at the ground so that

$$f_T(z=0, t) \equiv 0$$

is\*

$$f_T(z, t) = \frac{2g}{\pi} \exp(z-z_1)/2H \int_0^\infty d\kappa \exp-\kappa t \left( \kappa^2 + \frac{1}{4H^2} \right) W(\kappa, z, z_0) W(\kappa, z_1, z_0), \quad (B.10)$$

where

$$W(\kappa, z, z_0) = \frac{\left[ \kappa_T K_t \cos \kappa_T z_0 + \frac{K_t - K}{2H} \sin \kappa_T z_0 \right] \sin \kappa(z-z_0) + \kappa K \sin \kappa_T z_0 \cos \kappa(z-z_0)}{\sqrt{\left[ \left( \frac{K_t - K}{2H} \right) \sin \kappa_T z_0 + \kappa_T K_t \cos \kappa_T z_0 \right]^2 + \kappa^2 K^2 \sin^2 \kappa_T z_0}} \quad (B.11)$$

and

$$\kappa_H = \sqrt{\left( \kappa^2 + \frac{1}{4H^2} \right) d - \frac{1}{4H^2}} \quad (B.12)$$

$$d \equiv \frac{\text{stratospheric } K}{\text{tropospheric } K} = \frac{K}{K_t} \quad ; \text{ i.e., } 0 \leq d \leq 1 \quad (B.13)$$

The function  $f_T(z, t)$  cannot be expressed in terms of tabulated functions, but the total stratospheric burden of tracer, which is the quantity that is analyzed here, can be expressed as a single integral that can be evaluated numerically--see Eq. (B.15) below.

\* A derivation of this result, using transform techniques appropriate for the boundary conditions, has been given by W. Wasyliwskyj, IDA Inter-Office Memorandum of 1 July 1977, and addendum of 2 September 1977, "A one-dimensional model for studying diffusion of injectants in the stratosphere." Copies of this memorandum are available on request. It may be verified by direct substitution that Eq. (B.10) is indeed a solution of the problem.

For comparison with the results of Fig. B-1, which gives the total measured stratospheric burden of Zr-95 as a function of time, we need the total calculated stratospheric burden of tracer,

$$B_j(t) = \int_{z_0}^{\infty} n(z) f_j(z,t) dz; \quad (j=I,S,T) \quad . \quad (B.14)$$

Numerical calculations of  $B_j(t)$  have been made using the two-step model T of Eq. (B.10). Significant qualitative insight\* can be gained with the simple model I of Eq. (B.6) which gives

$$B_I(t) = \int_{z_0}^{\infty} n(z) f_I(z,t) dz = n_0 q e^{-(z_I - z_0)/H} U(x_0) \quad , \quad (B.15)$$

where

$$x_0 = (1/2)(Kt)^{1/2} \left[ (1/H) - (z_I - z_0)/Kt \right] \quad ; \quad (B.16a)$$

$$U(x_0) = \begin{cases} 1/2(1 + \operatorname{erf} x_0) & \text{for } x_0 < 0 \\ 1/2(1 - \operatorname{erf} x_0) & \text{for } x_0 > 0 \end{cases} \quad (B.16b)$$

The overall relationship between time  $t$ ,  $x_0$ , and  $U(x_0)$  is given in Table B-1.

\* There are quantitative defects in model I, which gives high values of  $K$  because the relatively fast transport in the troposphere cannot be simulated in any other way by this model.

TABLE B-1.  $x_0$  AND  $U(x_0)$  FROM EQ. (B.9) AS FUNCTIONS OF TIME (FROM MODEL I)

<u>Time t</u>	<u>Small</u>	<u><math>H(z_1 - z_0)/K</math></u>	<u>Large</u>
$x_0$	large, negative	0	$(Kt)^{1/2}/2H$
$U(x_0)$	1	0.5	$(1/2)(1 - \text{erf } x_0) \rightarrow 0$ as $t \rightarrow \infty$

The physical meaning of Eqs. (B.15 and B.16) is relatively clear-cut. The quantity  $qn_0 e^{-(z_1 - z_0)/H}$  in Eq. (B.15) is the total number of molecules per unit area injected at  $t = 0$  at  $z = z_1$ ;  $x_0$  is a time-dependent variable, and  $U(x_0)$  is the fraction of injected material that remains in the stratosphere after time  $t$ , where  $x_0 = x_0(t)$ .

From Table B-1 we see that a simple way to determine  $K$  is from the time  $t_{I;1/2}$  at which  $U(x_0)$  or the stratospheric burden in the approximation I has half its initial value, because

$$t_{I;1/2} = (z_1 - z_0) H/K \quad . \quad (B.17)$$

This result shows qualitatively how the effective stratospheric  $K$ -value depends on the decay time of the stratospheric burden and also on the effective injection height above the tropopause. Note, in particular, that a given decay rate ( $1/t_{I;1/2}$ ) may be obtained by rapid transport ( $K$  large) through a large distance ( $z_1 - z_0$ ), i.e., a *low* tropopause; or by *slow* transport ( $K$  small) and a *high* tropopause, i.e., slow transport through a short distance only.

Note that the net transport rate in the stratosphere is proportional to  $K(z) n(z) \partial f / \partial z$ . In comparing the infinite model I with the two-step model T, we note that in the lower stratosphere  $|\partial f_I / \partial z| < |\partial f_T / \partial z|$  because of  $f_T \approx 0$  at the tropopause while  $f_I(z_0) \neq 0$  [note that at early time  $f_T(z_1) \approx f_I(z_1)$ ]. Thus, for a given value of  $K$  in the stratosphere, model I gives significantly

faster transport than does model T, and conversely, to explain a given set of data with model T requires a *smaller* K-value than does model I.

For the two-step case T, an expression for the stratospheric burden  $B_T(t)$  in the form of a single integral which can readily be evaluated numerically is given below:

$$B_T(t) = \frac{2qn_0}{\pi} e^{(z_0 - z_1)/2H} \int_0^\infty d\kappa e^{-\kappa_S t \left( \kappa^2 + \frac{1}{4H^2} \right)} \frac{1}{\kappa^2 + \frac{1}{4H^2}} \quad (B.18)$$

$$\frac{\left[ \left( \kappa_T \cos \kappa_T z_0 + \frac{1-d}{2H} \sin \kappa_T z_0 \right) \kappa + \frac{\kappa d}{2H} \sin \kappa_T z_0 \right] \left[ \left( \kappa_T \cos \kappa_T z_0 + \frac{1-d}{2H} \sin \kappa_T z_0 \right) \sin \kappa(z_1 - z_0) + \kappa d \sin \kappa_T z_0 \cos \kappa(z_1 - z_0) \right]}{\left( \frac{1-d}{2H} \sin \kappa_T z_0 + \kappa_T \cos \kappa_T z_0 \right)^2 + \kappa^2 d^2 \sin^2 \kappa_T z_0}$$

Here,  $\kappa_T$  is defined in Eq. (B.12) and  $d$  is defined in Eq. (B.13). Note that the value of  $\kappa_T$  passes through zero as  $\kappa$  goes from 0 to  $\infty$ ; when

$$\left( \kappa^2 + \frac{1}{4H^2} \right) d - \frac{1}{4H^2} < 0, \quad (B.19a)$$

we must make the substitution

$$\left. \begin{aligned} \cos \kappa_T z_0 &\longrightarrow \cosh \kappa_T z_0 \\ \sin \kappa_T z_0 &\longrightarrow i \sinh \kappa_T z_0 \end{aligned} \right\} \quad (B.19b)$$

in the integrand of Eq. (B.18).

It is of interest to compare the solution  $f_T$  of Eq. (B.10) with the much simpler solution  $f_S$  of Eq. (B.7), bearing in mind that

$$\lim_{d \rightarrow 0} f_T = f_S(z_2 = z_0); \text{ i.e., a sink at the tropopause, } \quad (\text{B.20a})$$

because  $K \ll K_t$

$$\lim_{d \rightarrow 1} f_T = f_S(z_2 = 0); \text{ i.e., a sink at the ground if } \quad (\text{B.20b})$$

$$K = K_t$$

Some representative results for the burden  $B_S(t)$  and  $B_T(t)$  are shown in Table B-2 for various values of the parameters. We see that for short times (about 1-4 months) the  $d$ -dependence of  $B_T(t)$  is very small, but for the times of interest here, which are typically 8-16 months, there is a significant variation between the values of  $B_T(t)$  for  $d \sim 0.03 - 0.1$  (which are considered to be representative), and the limit  $d \rightarrow 0$ . The present calculations are reported for  $d = 0.03$ ; the choice of  $d$  affects  $B_S(t)$  and thus the rate of transport out of the stratosphere for a given value of  $K$ , but the numerical value of the eddy diffusivity in the troposphere,  $K_t = K/d$ , is not important for the subsequent discussion.

TABLE B-2. STRATOSPHERIC BURDEN  $B_T(t)$  FOR THE TWO-STEP MODEL AS A FUNCTION OF TIME, FOR VARIOUS VALUES OF  $d = K_{\text{stratosphere}}/K_{\text{troposphere}}$

$d = K_{\text{strat}}/K_{\text{trop}}$	Time, months				
	<u>1</u>	<u>4</u>	<u>8</u>	<u>12</u>	<u>16</u>
$0^a$	2.515	1.993	1.382	1.017	0.782
0.01	2.516	2.003	1.392	1.026	0.790
0.03	2.516	2.020	1.412	1.043	0.804
0.1	2.517	2.066	1.480	1.105	0.857
0.3	2.518	2.131	1.614	1.258	1.003
$1^b$	2.520	2.217	1.807	1.518	1.303

We show values of  $B(t)/10^{18} \text{ g}$  for injection height  $z_1 = 18 \text{ km}$ , tropopause height  $z_0 = 11 \text{ km}$ , stratospheric eddy diffusivity  $K = 10^4 \text{ cm}^2/\text{sec}$ .

<sup>a</sup>This is actually case S,  $z_2 = z_0 = 11 \text{ km}$  - see Eq. (B.20a)

<sup>b</sup>This is case S,  $z_2 = 0$  - see Eq. (B.20b)

### B.3.2 Initial Condition

The initial Zr-95 profile as a function of height used here is taken from Telegadas (1974), Fig. 45. It can be fitted quite well to a Gaussian profile

$$f(z, t_0) = f_0 \exp \left\{ - (z-z_1)^2 / \sigma_0^2 \right\} \quad (\text{B.21})$$

with  $\sigma_0 = 2.15$  km, which can be reconciled with the delta-function injection of Eq. (B.5) by the equivalence

$$\sigma_0^2 = 4 K t_0 \quad (\text{B.22a})$$

$$t_{\text{calc}} = t_{\text{obs}} + t_0 \quad (\text{B.22b})$$

where  $t_{\text{calc}}$  = time from a delta function injection, and

$t_{\text{obs}}$  = time after the nuclear explosion.

Representative values of  $t_0$  are shown in Table B-3 as functions of  $K$ . For  $K \gtrsim 3 \times 10^3$  cm<sup>2</sup>/sec the  $t_0$  values are so small compared to the observation times shown in Fig. B-1 that the equivalence of Eq. (B.22) is indeed satisfactory.

TABLE B-3. TIME CORRECTION  $t_0$  AS A FUNCTION OF  $K$  [SEE EQ. (B.22a).]

$K, \text{cm}^2/\text{s}$	$t_0, \text{months}$
$10^3$	4.4
$3 \times 10^3$	1.5
$10^4$	0.44
$3 \times 10^4$	0.15

### B.3.3 Correction for Sedimentation

Zr-95, like most other radioactive isotopes, is carried on small particles whose mean radius lies in the range 0.02  $\mu\text{m}$  to



0.15  $\mu\text{m}$  (see Drevinsky and Pecci, 1965; Telegadas and List, 1969). We assume that the density of the particles is  $\rho = 2 \text{ g/cm}^3$  and that the mean radius  $R = 0.1 \text{ }\mu\text{m}$ , as did Telegadas and List (1969). Spherical particles of this density and radius have a sedimentation speed  $v_s = 3.6 \times 10^{-3} \text{ cm/sec}$  at an altitude of 18 km (see, e.g., Junge et al., 1961), which corresponds to a net settling of about 100 m per month. One way to correct for sedimentation is to assume that the mean injection height falls with the effective sedimentation speed  $v_s$ . Thus, the effective injection height above the tropopause is

$$\tilde{z}_{1,0}(t) = z_{1,0} - \int_0^t v_s [R, \tilde{z}_{1,0}(t)] dt, \quad (\text{B.23})$$

since the sedimentation speed depends on radius and on ambient height (or density). A plot of  $\tilde{z}_1(t)$  is given in Fig. B-3, for  $\rho = 2 \text{ g/cm}^3$ ,  $R = 0.1 \text{ }\mu\text{m}$ .

With this correction, we replace  $x_0$  of Eq. (13) by

$$\tilde{x}_0 = 1/2 (Kt)^{1/2} \left[ (1/H) - (\tilde{z}_{1,0}(t)/Kt) \right], \quad (\text{B.24})$$

and thus  $U(x_0)$  by  $U(\tilde{x}_0)$ .

It has been pointed out (by H.S. Johnston, private communication, 1975; also Poppoff, Whitten, and Turco, 1978) that the residence time of aerosols is very sensitive to particle size and could be affected by aerosol growth and coagulation processes. In keeping with the use of a relatively simple model, we make the present simple estimate of the effects of sedimentation. Note, however, that the effect of sedimentation on the present estimate of stratospheric K-values is particularly significant for relatively small stratospheric diffusion distances ( $z_1 - z_0$ ), i.e., for high values of the assumed mean tropopause. Overall, the correction for sedimentation introduces significant uncertainties, and it may be desirable to reexamine the present estimate on the basis of any additional experimental data.

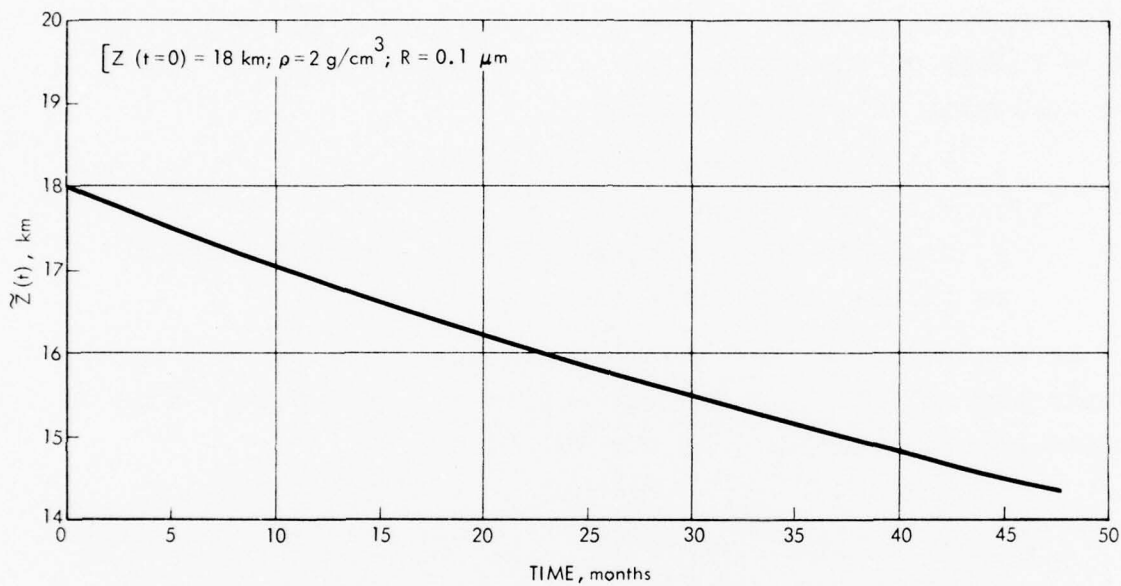

7-20-76-17

FIGURE B-3. Effective injection height for aerosols as a function of time,  $Z(t)$ .

#### B.3.4 Data Reduction for (K, z<sub>0</sub>) Parameterization

To reduce the data, we normalize the tracer concentrations shown in Fig. B-1 to give

$$A_{\text{exp}}(t) = \frac{\text{tracer burden (corrected for decay)}}{\text{maximum burden observed for the event}} \quad . \quad (\text{B.25})$$

This quantity is shown in Fig. B-4, where we also show calculated values of the normalized tracer burden,  $A_{\text{calc}}(t)$ , for the following set of parameters:

- $z_0 = 11$  km - height of tropopause
- $z_1 = 18$  km - height of injection
- $z_1$  from Fig. B-3 to correct for sedimentation from an initial 18-km injection.

We see from Fig. B-4 that experimental data for all five events extend to  $A_{\text{exp}} \leq 0.6$  but not to  $A_{\text{exp}} \leq 0.5$ , and thus we define the quantity  $t_{0.6}$  by the relation

$$A_{\text{exp}}(t_{0.6}) = 0.6 \quad (\text{B.26})$$

and use  $t_{0.6}$  rather than  $t_{1/2}$ , which cannot be determined from all five events) to compute  $K$  for a given value of  $z_0$ .

Note in Fig. B-4 (or Fig. B-1) that the stratospheric burden due to the October 1970 shot falls rather abruptly some 7 months after the event. While this decrease may be spurious (since the later values of burden are lower-bound values due to contamination from the French tests of summer 1971), yet it may be correlated with the fall in mean altitude in the profile some 4 months after the event shown in Fig. B-2. In the analysis, we shall use the three events of June 1967 (slow decay-summer), September 1969 (intermediate decay-fall), and December 1968 (fast decay-winter) as representative of the data. The characteristic times  $t_{0.6}$  for these events are listed in Table B-4.

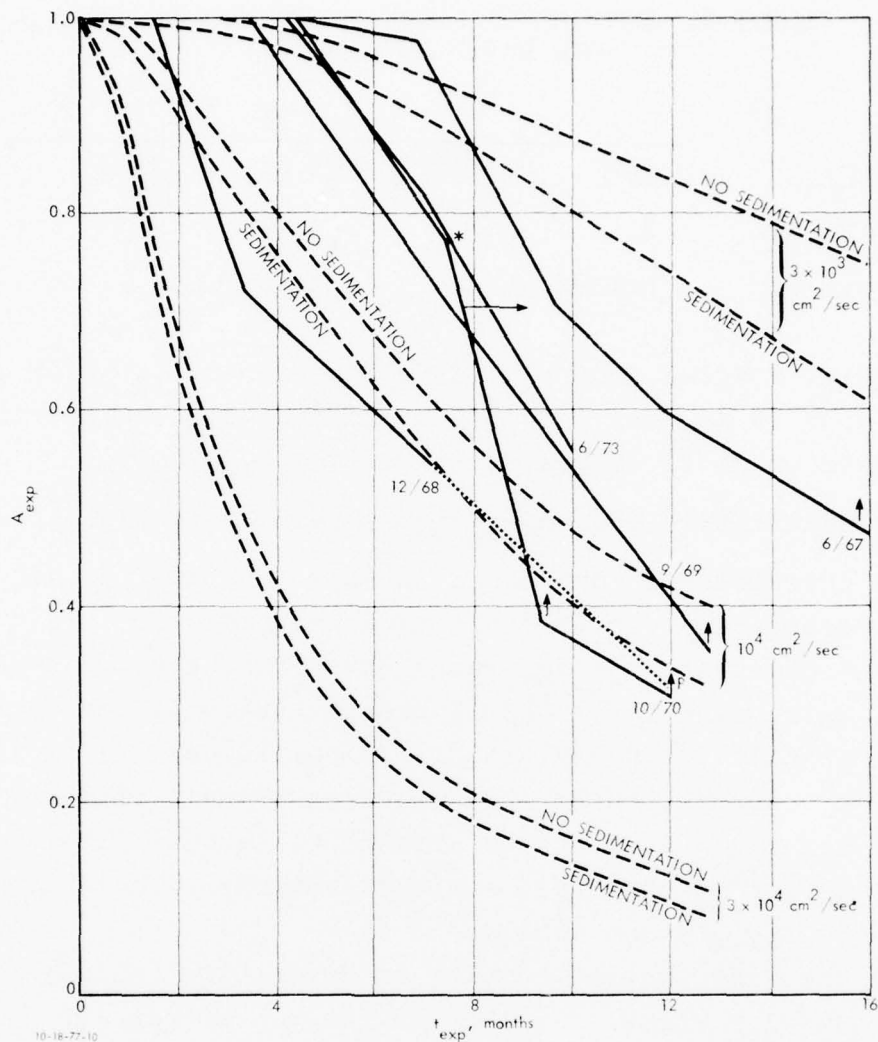

FIGURE B-4. Decay of stratospheric tracer burden as a function of time. Comparison of results from the Chinese tests (from Telegadas, 1974, 1976) with the predictions of the "T" model with and without sedimentation for various eddy diffusivity ( $K$ ) coefficients. Note that the final data points marked with an arrow are lower-bound values, as the radioactivity data from the Chinese tests were obscured by new fallout from later (French) tests. Tropopause height taken as 11 km,  $d = 0.03$ . Note that the data of 10/70 fall abruptly at \*; this correlates with the earlier motion down of the peak. Also, the data of 12/68 have been extrapolated to the 12-month point P used to determine  $A_{exp}$  (12 mos.) for the analysis of Eq. (27).

TABLE B-4. EXPERIMENTAL PARAMETERS FOR VARIOUS TESTS  
USED IN THE DATA ANALYSIS

Parameter	Test of				
	12/68	10/70	9/69	6/73	6/67
$t_{0.6}$ (month)	5.7	8.2	9.0	9.45	11.7
$A_{exp}$ (12 months)	(0.305)		(0.555)		0.59

In Fig. B-5, we show  $K_{eff}$  as a function of  $t_{0.6}$  for  $z_0 = 11$ , 14 km,  $z_1 = 18$  km, and as  $z_1(t)$  from Fig. B-3, correcting for sedimentation as is suggested in Section B.3.3.

The qualitative character of the results is plausible:

- a. Increasing  $z_0$  decreases  $(z_1 - z_0)$  and thus [cf. Eq. (B.17)] decreases  $K$  for a given time delay;\*
- b. Sedimentation accelerates transport; i.e., a smaller value of  $K$  is needed if sedimentation is considered than if it is neglected. In particular, for a 14-km tropopause, which only requires transit through  $(z_1 - z_0) = 4$  km in the stratosphere, very little diffusion is needed to supplement the sedimentation as predicted by the present model.
- c. The experimental results in summertime call for a much smaller value of  $K$  than do the winter results.

A different way to analyze the data is to obtain an annual average of activity; i.e., to ask for the activity 12 months after the event and to match this with the model as a function of  $K$ , rather than by asking for the time  $t_{0.6}$  of Eq. (B.26). We see from Figs. B-1 and B-4 that for the fast event of December 1968, there are no data as late as 12 months after

\* Note that the quantitative relation of Eq. (B.17) that for a given removal rate, the ratio of  $K$  to  $(z_1 - z_0)$  is constant, is not satisfied for the present model T.

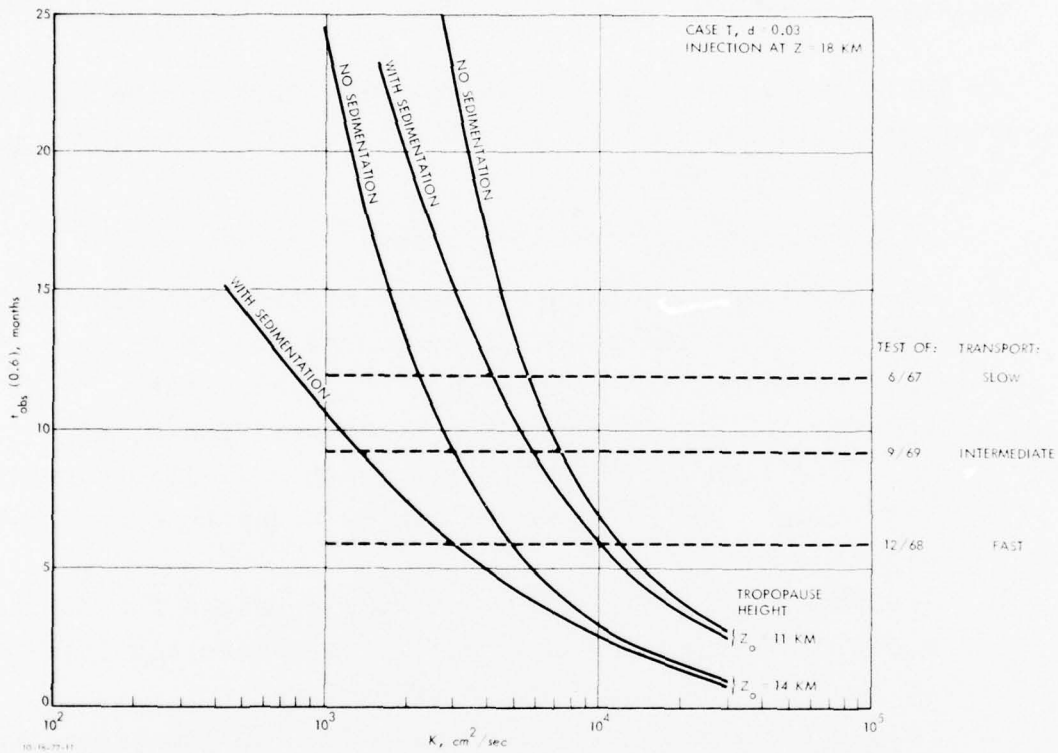

FIGURE B-5. Time for stratospheric tracer burden to decrease to 60 percent of its peak value,  $t_{0.6}$ , computed with and without sedimentation, shown as a function of eddy diffusivity  $K$ . Calculations are shown for tropopause height  $z_0 = 11$  and 14 km. The corresponding decay times calculated from the various nuclear explosions are also shown.

the event, but by extrapolation we obtain the point P in Fig. B-4 which is used here; the  $A_{\text{exp}}$  values used here are listed in Table B-4.

Explicitly, we obtain K from the relation

$$A_{\text{exp}}(t_{\text{obs}} = 12 \text{ months}) = A_{\text{calc}} [t_{\text{calc}} = 12 \text{ months} + t_0(K); (K)] \quad (\text{B.27})$$

In Table B-5 we show effective mean K-values in the lower stratosphere obtained from  $t_{0.6}$  [see Eq. (B.26)] and from  $A_{\text{exp}}$  (12 months) [see Eq. (B.27)].

The following points should be noted:

- a. The K-values corrected for sedimentation are considered preferable to those not so corrected (but note the limitations of the correction, especially for  $z_0 = 14$  km).
- b. The two different procedures of determining K, of Eq. (B.26) and Eq. (B.27), give rather similar numerical values; the differences can be understood on physical grounds.
- c. The significant difference between K-values for summer and winter injection can readily be understood in terms of the experimental results of Fig. B-1.
- c. Calculations have also been made for varying injection heights,  $z_1 = 16, 20$  km, with reasonable consequences, in that larger values of  $z_1 - z_0$  require smaller values of K to compensate, etc.

#### B.4 APPLICATION TO STEADY-STATE INJECTION

Given the effective stratospheric K-values deduced here, it is possible to compute atmospheric residence times and injection coefficients for the continuous injection of tracers (injected at 18 km altitude and 40°N latitude), by using the present model for a K-profile [cf. Eq. (B.2)].

TABLE B-5. EFFECTIVE K-VALUES COMPUTED FROM EXPERIMENTAL DATA  
(IN  $10^3 \text{ cm}^2/\text{sec}$ )

<u>Experimental Situation</u>	<u>June 1967 Slow-Summer</u>	<u>September 1969 Intermediate-Fall</u>	<u>December 1968 Fast-Winter</u>
<u>Tropopause at 11 km</u>			
From A(12 mo.), i.e., 12-month average			
With sedimentation	4.0	4.5	10.5
Without sedimentation	5.5	6.1	14.0
From $t_{0.6}$ - decreases to 0.6 of maximum			
With sedimentation	4.3	6.2	10.3
Without sedimentation	6.1	7.9	12.0
<u>Tropopause at 14 km</u>			
From A(12 mo.)			
With sedimentation	0.77	0.95	4.1
Without sedimentation	2.2	2.6	6.9
From $t_{0.6}$			
With sedimentation	0.5	1.35	3.0
Without sedimentation	1.8	2.9	5.2

NOTE: We use model "T", with  $d = K_{\text{strat.}}/K_{\text{trop.}} = 0.03$



The atmospheric residence time  $t_R$  is defined as atmospheric burden/flux, while the injection coefficient  $\alpha$  is defined for a steady state by McElroy et al. (1974)--see also Hunten (1975)--as follows:

$$\alpha = X/Q \quad (\text{B.28})$$

where  $X$  - molecular mixing ratio at and above the injection height  $z_1$  (which is constant in a steady state), and  $Q$  = source strength.

For the case of an isothermal stratosphere with scale height  $H$  (= 6.3 km, corresponding to  $T = 216^\circ\text{K}$ ), and an isothermal troposphere with scale height  $H_t$ , and for the  $K$ -profile of Eq. (B.2) we have the following expressions for gaseous tracers:

$$t_R = \frac{H}{K} (z_1 - z_0) + \frac{H_t}{K_t} \left[ z_0 - H_t \left( 1 - e^{-z_0/H_t} \right) \right], \quad (\text{B.29})$$

$$\alpha = \left( \frac{H}{Kn_0} \right) \left[ e^{(z_1 - z_0)/H} - 1 \right] + \frac{H_t}{K_t n_0} \left[ 1 - e^{-z_0/H_t} \right]. \quad (\text{B.30})$$

For aerosols, the treatment is more complex [see Bauer, Gardner, Oliver (1977)]. Here we confine the discussion to gaseous injections, which are of greatest interest.

Given these formulae, we can compute injection coefficients and residence times for various values of the spatial and temporal mean eddy diffusivity coefficient  $\bar{K}$  (between 18 km and the tropopause) as derived from the experimental data. Before doing so, however, some discussion of the appropriate mean on a time-weighted basis is necessary.

Let us reexamine how material leaves the stratosphere. From Fig. B-1, it appears that material injected in summer does not leave at all until the following winter. However, the  $A_{\text{exp}}$  (12 month) estimates of Eq. (B.27) do provide annual mean  $K$ -value for a summer injection. Here we shall use an annual average

$$\bar{K} = 1/2 (K_{\text{summer}} + K_{\text{winter}}) \quad (\text{B.31})$$

based on the  $A_{\text{exp}}$  (12-month) estimates, taking into account the effects of sedimentation. The results obtained in this way are compared with those of some other studies in Table B-6. Referring to Fig. B-2, we see that an annual mean tropopause height  $z_0 = 11$  km is most appropriate; we show results also for a high tropopause,  $z_0 = 14$  km, for which the short diffusion distance implies that  $\bar{K}$  is quite small and the effects of sedimentation are extremely important.

In Fig. B-6 we compare the present estimates of  $K$  with those of several current models listed in Table B-6. Note the effects of sedimentation on an annual-average basis, and in particular the wide variation between effective  $K$ -values for summer and winter injection.

#### B.5. A FINAL COMMENT

The most striking characteristic of the radioactive fallout data of Telegadas (1974 and 1976) is that they display a very strong seasonal variation, with transfer to the troposphere being much more rapid in late fall and winter than in summer. This effect is not included in most one-dimensional models, in which an *annual average* eddy diffusivity profile is used, and may have resulted in an overestimate by such models of the calculated ozone reduction following the massive Soviet atmospheric nuclear tests of fall 1961 and fall 1962 [see Foley and Ruderman (1973), Bauer and Gilmore (1975), and p. 159 of NAS (1975)].

AD-A063 586

INSTITUTE FOR DEFENSE ANALYSES ARLINGTON VA  
RECENT DEVELOPMENTS IN THE ESTIMATION OF POTENTIAL EFFECTS OF H--ETC(U)  
OCT 78 R C OLIVER, E BAUER, W WASYLKIWSKYJ DOT-FA77WA-3965  
P-1343 FAA-AEE-78-24 NL

UNCLASSIFIED

3 OF 3

AD A063586



END  
DATE  
FILMED  
3-79  
DDC

TABLE B-6. COMPARISON OF RESULTS FROM DIFFERENT MODELS  
FOR 18-km INJECTION

<u>Source</u>	$\alpha,$ <u><math>10^{-17} \text{ cm}^2\text{-sec}</math></u>	<u><math>t_R,</math></u> <u>yr</u>
<u>This analysis (two-step case "T", d = 0.03)</u>		
<u>11 km tropopause</u>		
With sedimentation ( $\bar{K} = 7.25 \times 10^3 \text{ cm}^2/\text{sec}$ )	2.4	2.0
Without sedimentation ( $\bar{K} = 9.75 \times 10^3 \text{ cm}^2/\text{sec}$ )	1.8	1.5
<u>14 km tropopause</u>		
With sedimentation ( $\bar{K} = 2.44 \times 10^3 \text{ cm}^2/\text{sec}$ )	5.0	3.5
Without sedimentation ( $\bar{K} = 4.55 \times 10^3 \text{ cm}^2/\text{sec}$ )	2.5	1.9
<u>Other K-Profiles*</u>		
Chang (1974)	1.7	1.4
Chang (1976)	1.8	1.6
Hunten (1974)	4.6	3.6
Hunten (1974) (+2)(18 km, latitude adjusted to 20 km)	7.1	4.6
Crutzen (1974)	1.8	1.7
Crutzen-Isaksen (1975)	1.9	1.7
Wofsy (1975)	3.2	2.6
Crutzen et al. (1978)	2.3	2.0

\*The more recent (1975-78) eddy diffusivity profiles used here are shown in Fig. B-6; the older ones, which were used during CIAP, are listed in Oliver et al. (1977). All estimates are made for 18-km injection, except for the "Hunten (1974) (+2)" estimate which corresponds to a 20-km injection as an adjustment for the latitude variation of mean tropopause height, the procedure recommended in NAS (1975), p. 118. Conceivably, other profiles should be similarly adjusted, but we have seen no such recommendation for the other profiles.

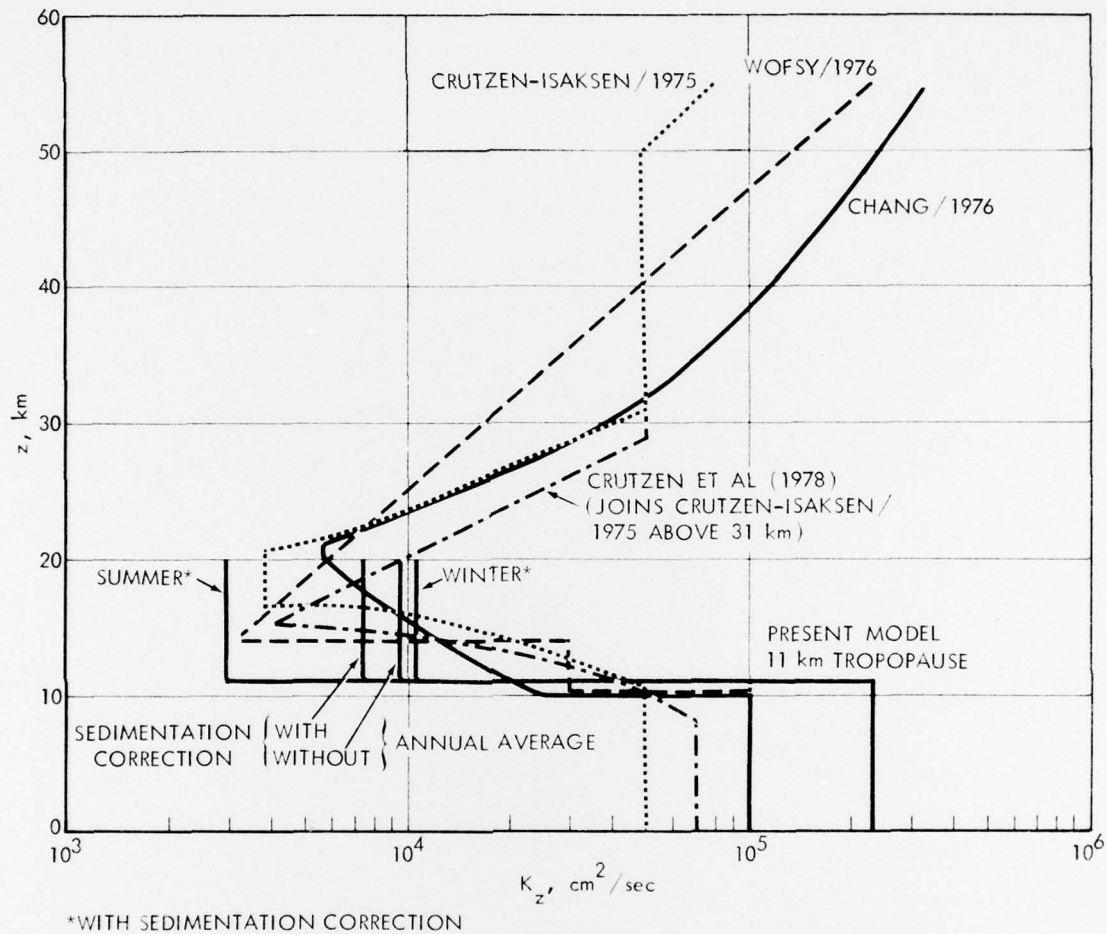

FIGURE B-6. The present results for an 11 km tropopause compared with some other, currently used, eddy diffusivity profiles. Note the effect of sedimentation (see Section B.3.3) on an annual average bases, and also the large summer/winter variation.

## REFERENCES, APPENDIX B

- Bauer, E., K.A. Gardner, R.C. Oliver, "Computations of Injection Coefficients and Residence Times for 1-D Models," Appendix D to Oliver et al., 1977.
- Bauer, E. and F.R. Gilmore, "Effect of Atmospheric Nuclear Explosions in Total Ozone," *Revs. Geophys. Space Phys.*, Vol. 13, p. 451, 1975.
- Bauer, E., R.C. Oliver, and W. Wasylkiwskyj, "On the Use of Zr-95 Data from Chinese Atmospheric Thermonuclear Explosions to Study Atmospheric Motions in a One-Dimensional Parameterization," Appendix C to Oliver et al., 1977.
- COMESA, *The Report of the Committee on Meteorological Effects of Stratospheric Aircraft*, U.K. Meteorological Office, 1975.
- Crutcher, H.L., and O.M. Davies, *U.S. Navy Marine Climatic Atlas of the World*, Vol. 8, NAVAIR 50-10-54, Chief of Naval Operations, Washington, D.C. 1969.
- Crutzen, P.J., "A Review of Upper Atmosphere Photochemistry," *Can. J. Chem.*, Vol. 52, No. 8, pp. 1569-1581, 1974.
- Crutzen, P.J., I.S.A. Isaksen and J.R. McAfee, "The Impact of the Chlorocarbon Industry on the Ozone Layer," *J. Geophys. Res.*, Vol. 83, No. C1, pp. 345-363, January 20, 1978.
- Drevinsky, P.J., and J. Pecci, "Size and Vertical Distribution of Stratospheric Radioactive Aerosols," *Radioactive Fallout from Nuclear Weapons Tests*, A.W. Klement, ed., USAEC Publication, Symposium Series No. 5, pp. 158-182, November 1965.
- Feller, W., *An Introduction to Probability Theory and Its Applications*, 3rd Ed., Ch. 14, Wiley, 1968.
- Foley, H.M., and M.A. Ruderman, "Stratospheric NO Production from past Nuclear Explosions," *J. Geophys. Res.*, Vol. 78, pp. 44-41, 1973.

Grobecker, A.J., S.C. Coroniti, and R.H. Cannon, Jr., *CIAP Report of Findings: The Effects of Stratospheric Pollution by Aircraft*, U.S. Department of Transportation Report DOT-TST-75-50, December 1974.

Hunten, D.M., "Residence Times of Aerosols and Gases in the Stratosphere," *Geophys. Res. Lett.*, Vol. 2, p. 27, 1975

Junge, C.E., C.W. Chagnon, and J.E. Manson, "Stratospheric Aerosols," *J. Meteorol.*, Vol. 18, p. 81, 1961.

Lindzen, R.S., "Tides and Gravity Waves in the Upper Atmosphere," *Mesospheric Models and Related Experiments*, G. Fiocco, ed., D. Reidel, Amsterdam, 1971.

Machta, L., "Global Scale Atmospheric Mixing," *Adv. in Geophys.*, Vol. 18B, p. 33, 1974.

Machta, L., K. Telegadas, "Examples of Stratospheric Transport," *Proceedings, Second Conference on CIAP*, A.J. Broderick, Department of Transportation Report No. DOT-TSC-OST-73-4, April 1973.

Martin, B., "Critical Evaluation of Residence Times Calculated Using the Exponential Approximation," *J. Geophys. Res.*, Vol. 81, p. 2637, 1976.

McElroy, M.B., S.C. Wofsy, J.E. Penner, and J.C. McConnell, "Atmospheric Ozone: Possible Impact of Stratospheric Aviation," *J. Atmos. Sci.*, Vol. 31, p. 287, 1974.

National Academy of Sciences, *Halocarbons: Effects on Stratospheric Ozone*, Panel on Atmospheric Chemistry, National Research Council, 1976.

National Academy of Sciences, *Halocarbons Environmental Effects of Chlorofluoromethane Release*, Committee on Impacts of Stratospheric Change, National Research Council, 1976.

Oliver, R.C., et al., *Aircraft Emissions: Potential Effects on Ozone and Climate*, prepared for High Altitude Pollution Program, FAA-EQ-77-3, (IDA Paper P-1207) March 1977.

Poppoff, I.G., R.C. Whitten, R.P. Turco, and L.A. Capone, "An Assessment of the Effect of Supersonic Aircraft Operations on the Stratospheric Ozone Content," NASA Reference Publication 1026, September 1978.

Telegadas, K., *Radioactivity Distribution in the Stratosphere from Chinese and French High Yield Nuclear Tests (1967-1970)*, USERDA Report No. HASL-281, I-3, April 1974.

Telegadas, K., *Radioactivity Distribution in the Stratosphere from the Chinese High Yield Nuclear Test of June 27, 1973*, USERDA Report No. HASL-298, I-7, January 1976.

Telegadas, K., *An Estimate of Maximum Credible Atmospheric Radioactivity Concentrations from Nuclear Tests*, USERDA Report No. HASL-328, I-39, October 1977.

Telegadas, K., R.J. List, "Are Particulate Radioactive Tracers Indicative of Stratospheric Motions?", *J. Geophys. Res.*, Vol. 74, p. 1339, 1969.



U.S. DEPARTMENT OF TRANSPORTATION  
FEDERAL AVIATION ADMINISTRATION  
Washington, D.C. 20591  
Official Business  
PENALTY FOR PRIVATE USE, \$300

POSTAGE AND FEES PAID  
FEDERAL AVIATION  
ADMINISTRATION  
DOT 515



RECENT DEVELOPMENTS IN THE ESTIMATION OF POTENTIAL EFFECTS OF HIGH  
ALTITUDE AIRCRAFT EMISSIONS ON OZONE AND CLIMATE FAA-AEE-78-24