

AD-A063 560

NAVY ELECTRONICS LAB SAN DIEGO CALIF
THE BURIAL AND SCOURING OF GROUND MINES ON A SAND BOTTOM. (U)
SEP 58 R F DILL

F/G 19/8

UNCLASSIFIED

NEL-861

NL

1 OF 1
AD A
063560



END
DATE
FILMED

3 -79
DDC

~~CONFIDENTIAL~~
UNCLASSIFIED
unclassified

AD A063560

9 Research report 150
for period ending 1 Jan 58

14 NEL-867

6 the burial and scouring of ground mines
on a sand bottom (u)

11 23 Sep 58

12 35 p

10 ROBERT F. DILL

DDC FILE COPY

gr IV

Classified by: _____
Subject to general declassification
Schedule of Executive Order 11652
Automatically downgraded at two-year intervals
Declassified on 31 December 1964

DDC
RECEIVED
JAN 22 1979
A

DISTRIBUTION STATEMENT A
Approved for public release;
Distribution Unlimited

U. S. NAVY ELECTRONICS LABORATORY, SAN DIEGO, CALIFORNIA
A BUREAU OF SHIPS LABORATORY

253 550

UNCLASSIFIED
CONFIDENTIAL
unclassified

cop. 13

This document contains information affecting the national defense of the United States within the meaning of the Espionage Laws, Title 18, U.S.C., Sections 793 and 794. The transmission or the revelation of its contents, in any manner to an unauthorized person, is prohibited by law.

the problem

Determine the characteristics of environmental factors important in acoustic mine hunting. Applications: specification of optimal equipment characteristics and operational techniques for locating bottom mines, and prediction of detection probabilities.

This report covers a study of the behavior of ground mines and other objects on the sea bottom off Mission Beach, California.

results

1. When ground mines are placed on a sand bottom in areas subject to long-period swell (10 seconds or more), the main agents of burial are the oscillatory currents set up by swell.
2. Mines observed in this study when placed on a sand bottom did not roll or move from the point of placement more than 1 foot.
3. When hunting for mines in areas subject to open-sea wave conditions, the shallow-water areas should be investigated first because mines scour into the bottom faster in shallow water than deep water.
4. The burial of mines involves the following step-like process: (1) a rapid scour to equilibrium, (2) occasional deepening by storm-induced bottom currents, and (3) eventual burial when the mine no longer extends above the general level of the sea floor. This process is highly dependent on grain size of the sediment and the organisms contained in it.

recommendations

1. Perform additional work in other environments such as rock bottoms, mud bottoms, and cobble bottoms subject to strong tidal flow.
2. Set up a program to measure the bottom currents at various depths which are set in motion by a wave of a given period and height.
3. Expend considerable effort to develop an accurate navigation system for mine hunting operations.
4. Make available as soon as possible the AN/PQS-1 diver-held sonar to all units of the Navy engaged in mine hunting operations.

administrative information

This report covers work to 1 January 1958, and was approved for publication 23 September 1958. The work was done under AS 14101, NE 051456-19 (NEL E4-4) and AS 14101, NE 051456-846.12 (NEL L1-7).

The author wishes to thank the many persons who contributed to the field work for the study, particularly those who worked during bad weather and under uncomfortable conditions at sea. For their part in the diving and field work, special mention is due J. A. Beagles, E. C. Buffington, E. L. Hamilton, E. C. LaFond, C. Limbaugh, J. McGann, H. W. Menard, Jr., D. G. Moore, H. Nething, G. A. Shumway, H. B. Stewart, and the personnel of UDT 11 and 12.

Information on the biology of the areas studied and physical processes in shallow water was provided by A. J. Carsola, C. S. Cox, D. L. Inman, C. Limbaugh, A. B. Rechnitzer, and J. F. T. Saur.

The shaped objects used in a portion of this study were furnished by Aerojet-General Corporation, Azusa, California.

Special thanks are given to E. C. Buffington, G. H. Curl, and E. L. Hamilton who critically read the manuscript and who made many suggestions during the course of the field work.

ACCESSION FOR	
NTS	White Section <input checked="" type="checkbox"/>
DD	Buff Section <input type="checkbox"/>
UNANNOUNCED <input type="checkbox"/>	
JUSTIFICATION	
<i>Req. sub. - 78-277</i>	
BY <i>2272</i>	
DISTRIBUTION/AVAILABILITY CODES	
Dist.	AVAIL. and/or SPECIAL
A	

contents

page	
3	INTRODUCTION
4	PREVIOUS WORK
10	CHOICE OF AN AREA
10	THE MISSION BEACH AREA ENVIRONMENT
13	FIELD METHODS
15	FIELD OBSERVATIONS
20	DISCUSSION OF SCOUR
25	THE STABILIZATION OF MINES
29	CONCLUSIONS
30	RECOMMENDATIONS
31	REFERENCES

illustrations

page	figure	
8	1	Map showing positions of mines
11	2	Cyclic behavior of giant ripple marks
12	3	Jet coring profiles of sediments
12	4	Characteristics of oscillatory currents in shallow water
13	5	Arrangement of measuring stakes
14	6	Scour depression around a mine in 30 feet of water
15	7	Scour depression around a mine in 69 feet of water
16	8	Relative rates of scour for fine sand bottom and medium sand bottom
17	9	Scour depression at the nose of a mine
17	10	Shapes and sizes of objects used in the study
18	11	Scour depression of a hemi-oblate spheroid
19	12	Scour depression of a hemisphere
20	13	Scour depression of a free-flooding cylinder
21	14	Normalized random velocity distribution
22	15	Bottom profile off Mission Beach, California, showing test mines
24	16	Percentage of time that critical velocity is exceeded by bottom currents
25	17	Giant ripple marks
27	18	Gas-filled floats of <i>Macrocyctis</i>
28	19	Organic mat at Mission Beach

introduction

NATURE OF SCOUR

The sedimentary material which is found at any given location on the sea floor is, in general, in dynamic equilibrium with the current regime prevalent in that area. The placement of mines and other foreign objects on the sea floor upsets this established dynamic balance. On sea floors mainly composed of sand-sized particles, the velocity of localized currents caused by the compression of streamlines of water flow around a foreign object may surpass the "critical velocity"* of the sediment. If this is the case, individual sedimentary particles will be moved and, in some instances, lifted from the sea floor. This process is called "scour." It is primarily dependent on the velocity of bottom currents, the relationship of the bottom to the configuration of the object causing the disruption of the streamlines of flow, and the grain size and sorting of bottom sediments. In natural environments another important factor also affects scour, namely, the animal and plant content of the sediment. The interwoven plant and animal bodies found in subsurface sediments often provide sufficient reinforcement to give the sediment a tangible scour-resistant characteristic.

SCOPE OF REPORT

This report presents information derived from a study of scour and other environmental processes affecting a mine or other foreign object placed on a sand bottom. Because scour plays an important role in mine burial, the extent and rate of the scour process were emphasized in the study. Special attention was given to the variation of scour with water depth; scour relationship to bottom currents; the effect of object shape on scour development; the movement, if any, of objects placed on the sea floor; and the function of sediment grain size within the range commonly classified as sand in the Wentworth scale of sediment sizes (median diameters 0.062 mm to 2.000 mm).

Actual mine cases were used in this study so as to reproduce operational conditions that would be encountered in mine hunting over a sand bottom. Nevertheless, some caution must be exercised when extrapolating the data in this report to other areas which have sand bottoms. The classification of the sea floor as a specific environment is dependent on many factors, only one of which is the bottom type. Particular care must be exercised when utilizing bottom notations or current data taken from published charts of Hydrographic Office Oceanographic Data Sheets (HOODS); the original data which provide the basis for these notations are usually not taken in sufficient detail to permit extrapolation of mine behavior from one area to another. However, in some cases sufficient information is available to classify one area as environmentally similar to another; in these cases criteria developed in one area should be applicable to others regardless of location.

SAND BOTTOM CHARACTERISTICS

Large areas of the continental shelf throughout the world are predominantly covered by sand. Shepard¹ (see list of references at end of report) estimates that 60 ± 10 per cent of the total area of all the continental shelves are covered by

* Critical velocity is the theoretical current velocity at which sediment of a given grain size will be moved. This concept is discussed more fully on pages 20 to 22.

sand-sized sediments. In Southern California between Point Conception and the Mexican border, in an area bounded by the 150-foot-depth contour and the shoreline, over 50 per cent of the bottom is covered with sand sediment. Sand bottoms thus occur in a considerable percentage of mineable waters, and so the behavior of mines on such bottoms is of major importance in mine hunting operations.

Bottoms composed mainly of sand feature some specific recognizable characteristics. The sea floor is relatively flat, with local variations in relief rarely exceeding 6 inches in height. The bottom is firm and withstands great initial loads. This initial strength is deceptive, however, for the ability of the sand bottom to act as a permanent platform for objects, even large ones, is limited by its extreme susceptibility to scour, particularly in the relatively shallow water where mining is effective.

The sand bottom, in spite of its instability for emplaced objects, is still the most favorable bottom type for present day mine hunting operations. Drags and grapnels do not snag on obstructions such as those found in rock areas; mines do not sink far beneath the surface of the sea floor as they have been reported to do in soft-mud areas; and, although bottom reverberation is relatively high, the sand bottom does not restrict acoustic mine hunting as badly as do areas with rock and cobble bottoms.

Sand bottoms are usually associated with variable oceanographic conditions, particularly bottom currents. Conditions which are unfavorable for mine hunting may change radically within a very short time and become favorable, sometimes within hours. This is especially true for acoustic and visual mine hunting operations.

previous work

In general, there is a lack of published data on the exact changes that take place, with time, when a mine is placed on the sea floor. Reports are numerous, however, on what is *thought* to happen, and an extensive lore on mine behavior in various environments has accumulated over the past 20 years. Most reports on mine behavior in various environments are largely suppositions or deductions from indirect evidence as to what might have caused the disappearance of a sonic contact or the failure of a certain equipment to find a mine. A typical example of the use of indirect evidence to deduce a mine's behavior on the bottom is the statement quoted below. This statement is followed by some remarks which are intended as objective comments and not as criticism; it is fully appreciated that, until recently, indirect methods were the only ones available for the study of mine behavior. The statement in question is from a report from the Commander Mine Squadron Five (CTG 59.2) to Commander Mine Force, U. S. Pacific Fleet,² and is as follows:

"During the first week at CORONADO ROADS, recovery of mines was accomplished by means of the MK 1 MOD Retriever. Conditions of all mine cases recovered showed that the bottom was hard and conducive to mines' rolling. Cases were shiny and paint was often scraped off; no silt was observed. Also, the position

in which mines were recovered were often so far from the positions in which mines were spotted during the aerial plant that it appeared that, even allowing for errors in mine spotting, the mines might have rolled. In the case of one mine, difficulty in recovery was experienced due to the fact that the nylon cord had wrapped two or three times around the mine case after the float had released, indicating that the mine might have rolled after the float surfaced. Swimmers had to attach the MK 1 MOD Retriever to this mine by taking it down and attaching it at the steel spear, the retriever not being capable of being slid down the cord in the cord's tangled condition.

"During the second week at CORONADO ROADS only one mine was recovered. This mine was caught in one of the galvanic drags during a turn the LCU made at a considerable distance outside the position of the field as established by spots of the aerial mine plant— further indication that the mines might have rolled."

Subsequent questioning by the writer of the personnel involved in this operation indicated that there had been some doubt in their minds as to the accuracy of the air drop positions. If the air drop positions are assumed accurate, the minimum distance these mines would have travelled was 250 yards and, in the case of one mine, 700 yards. To check the possibility that the mines could have actually moved these unusual distances, a mine case identical to that used in the air drop (Mark 36) was placed in the same area; as expected no rolling occurred, only rapid sand scour where the mine case touched the bottom and barely noticeable horizontal movement. Often overlooked in operational reports are the possible agents that could cause rolling. In most areas similar to CORONADO ROADS, the currents are never of sufficient velocity to move a mine of the size of the Mark 36, even if it were on a hard flat concrete surface. In addition, there is very little slope to the bottom in this area, thereby excluding gravity as a causal agent. The bottom in this area, when first seen by a diver, does appear to be flat, hard, and firm, and rolling would be a logical process to suspect if one could not find a mine. However, closer examination shows that the bottom in this area actually consists of a fine sand, with a median grain size within the range most susceptible to scour action by bottom oscillatory currents. Later discussions with the UDT personnel who did the diving on this operation indicated that scour was actively taking place around the mines when found, and that the mines were in scour depressions. That the paint had been worn from the mines is understandable, because any object on a fine sand bottom is continually subjected to an oscillating particle-laden current, a condition quite similar to sand blasting, and the mine could be expected to acquire a smooth polished look.

It has only been with the utilization of Self-Contained Underwater Breathing Apparatus (SCUBA) as a tool, to permit direct observations by scientific and technical personnel, that data in sufficient detail have become available for ascertaining events on the sea floor when a foreign object disturbs the natural environment. In most previous work conducted without the great advantage of direct observation, the first approach has usually been a series of flume experiments. In these studies objects of different sizes and shapes have been placed on different types of sediment and subjected to different current velocities. An example of this type of experiment is the work done by Kellogg and Reynolds³ who used models of the Mark 25 and Mark 36 mines under simulated current and

bottom conditions. Although conducted entirely in the laboratory their work gave some indication of what could be expected when a mine similar to the Mark 25 or Mark 36 is placed in an alternating current similar to natural currents associated with tide. They used variable velocities up to 0.6 knot to represent peak velocities around scaled models which were resting on a medium-sized sand bottom. Unfortunately, a scaled version of the sediment composing the bottom in nature differs in behavior from the natural sediment. Thus, the results of any flume studies can be, at best, only qualitative, and the shapes of the scour depressions, the rates of burial, and the possible changes that are reported in scale model studies are not totally applicable to natural conditions. However, the experiments showed that, even under the scaled conditions, there was no appreciable lateral movement of the models, even in the highest current, once scour had begun. There was only a downward movement and a slight tendency to move upstream as the mine settled into its gradually deepening depression. Similar movements have been observed by the writer in studies of real mines.

Realizing the limitations of flume studies, many researchers have resorted to indirect measurements of the sea floor from surface vessels. An ingenious instrument for measuring scour indirectly was used by Stetson and Hough.⁴ This instrument consisted of a tripod with feet mounted on a circular ring supporting a round head to which a ratchet, sliding in guides, had been screwed. The inside diameter of the ring was 35 inches and the diameter of the head 7 inches. Construction permitted disengagement of the head as the instrument hit the bottom; it was then free to sink into the bottom sediment as the scour developed at the point of contact. Upon being retrieved, the position of the head became fixed and the penetration for a given length of time could be measured. In spite of the usual mechanical difficulties encountered when working with instruments on the bottom, some of their data indicate that the round head would start to sink when tidal velocities had reached 0.5 knot over sand bottoms. At lower velocities the head remained at rest for considerable periods of time. At velocities of 1 knot or more, complete penetration (12 inches) was obtained in 4 to 5 minutes.

Some of the most extensive work on mine behavior in various environments over a period of time has been reported in a series of papers by members of the oceanographic section of the Narragansett Marine Laboratory (NML). Researchers from NML chose four areas along the New England coast which offered diversified sediment types, water depth, and current. A team approach was used to investigate the behavior of mines in these areas, engineers, geologists and oceanographers partaking. Donohue and Garrison,⁵ of NML, after selecting the general areas to be used in the studies, placed mines in carefully selected localities which typified the environment of the general area. They then made SCUBA observations of the changes which took place over a period of time. Their data are supplemented by oceanographic data from the area and are therefore extremely valuable for possible comparison with, and application to, other regions. The use of underwater photography by NML as a means of recording bottom conditions is noteworthy. This technique permits comparison studies. McMasters, Garrison, and Hicks⁶ in the same program studied the effect of Hurricane Carol on bottom mines. As far as they could determine, there was very little movement of the mines in their areas as a result of this storm. Some minor rolling was suspected with one mine because of the lack of paint and plant growth on the mine after the hurricane,

but this movement was insignificant as indicated by the mine's position relative to a 1/4-inch dowel driven into the bottom as a reference point. One of the main problems which this group encountered after the hurricane was the relocation of their mines. This difficulty was not due to the rolling or scouring of mines, but rather to the destruction of shore location points by the hurricane. Frazier and Miller,⁷ in the same series of studies, determined the strength of the sediments from the different areas. They showed that a sand bottom has sufficient structural strength to prevent a Mark 36 mine from sinking into the sea floor by its weight alone, and that scour must take place prior to sinking.

The results obtained by NML are comparable, in many instances, with those obtained in the present study, especially with regard to the sand environment. For example, McMasters *et al.* found little bottom penetration when their mines were dropped from the sea surface into 30 feet of water, and they also state:⁶ "Subsequent movement of mines after placement were minor and due to the granular readjustment of the sediment mass, to locally satisfy the profile of equilibrium with respect to the mine." NML's work differs from that of this report in that the effect of water depth and strong oscillatory current action was not considered. However, even though there were major differences in current type, both investigations resulted in similar conclusions as to the basic causes and extent of scour.

Much unpublished work on mine behavior has been done at NEL, and the experimental conditions for this study were largely based on this previous NEL work. An important fact which cannot be overemphasized is that much of this previous work had to be prematurely terminated because of the inability to find experimental mines after they had been placed on the bottom. All losses could be attributed to the inadequacy of commonly used navigational techniques for relocating over a given spot on the sea floor. These methods (sextant, compass bearings, etc.) are not of sufficient accuracy to allow investigators to consistently revisit experimental mines. The difficulties encountered in these early experiments point out the almost futile position of the Navy in actual mine hunting operations, without accurate electronic navigational systems. Even though the writer knew where mines were located to within a few feet, a situation *never* encountered in actual operations, relocation over a given spot on the sea floor was extremely difficult. Drift of the diving boat, poor visibility (fog, etc.), and turbid water make diving operations and the finding of bottom mines an extremely specialized task which requires considerable training.

Basic conclusions drawn from NEL previous unpublished work are:

1. Mines placed on a fine sand bottom in water depths of less than 25 feet and subject to periodic swell-induced currents will become completely buried within a short time (8 weeks).
2. In depths of water greater than 50 feet mines are not buried at the same rate as mines in the 25 foot depths, even though they are both on a bottom of similar grain size and subject to nearly the same oceanographic conditions.
3. In water depths greater than 80 feet there is very little scour regardless of surface swell conditions.

CONFIDENTIAL

Mills and Jackson,⁸ while performing contract work for NEL, studied the behavior of mines in two different environments: (1) the shallow bottom just off the NEL pier in San Diego Bay, and (2) the sand bottom at two depths (29 feet and 72 feet) in La Jolla Bay (fig. 1).

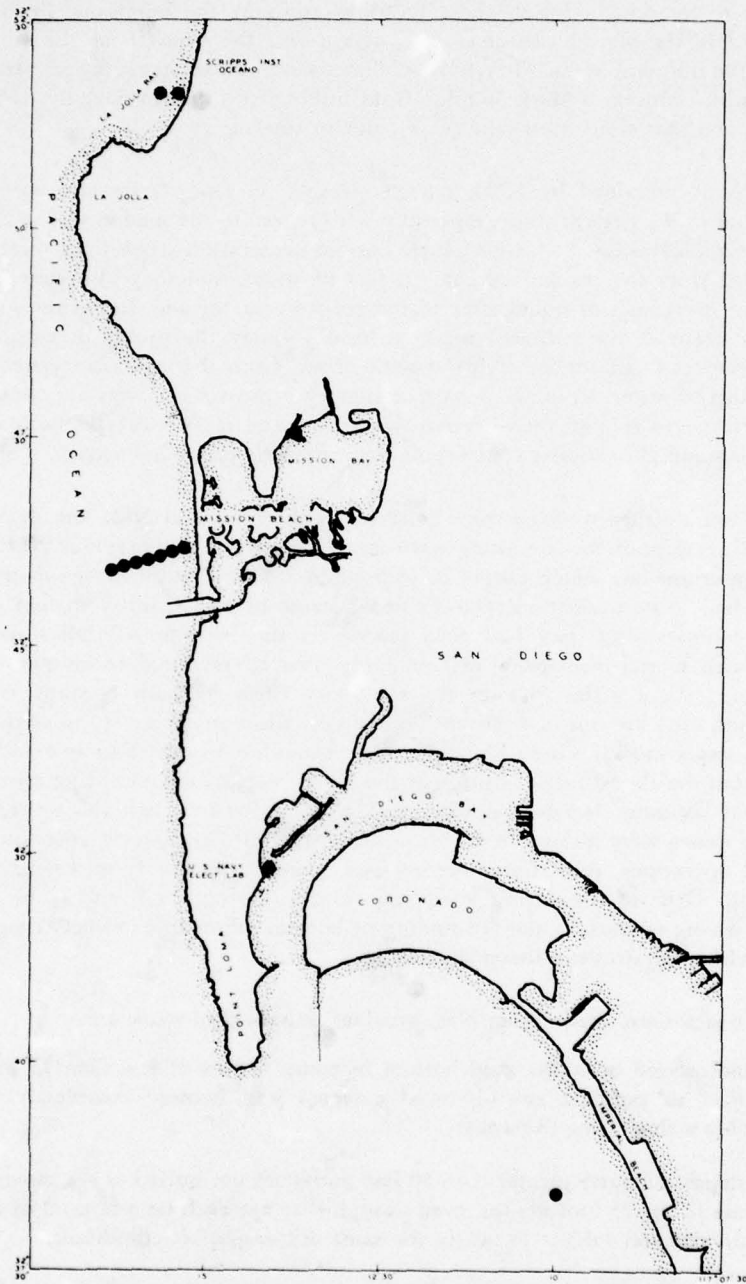

Figure 1. Map showing the positions of mines discussed in this study. Black dots represent mines.

8 CONFIDENTIAL

In San Diego Bay, the bottom is composed of a fine silt and shell sediment. Mines placed in this environment showed only moderate scour over a period of 1 year even though subject to periodic strong tidal currents. The scour depressions had reached equilibrium with the maximum bottom currents within the first 2 weeks after placement; this usually resulted in the mine sinking approximately one-third of its diameter into the sediment relative to the general level of the adjacent sea floor. Little change took place after this initial scour. Plant and organic growth on these mines was quite heavy after a short time, and the mines created a haven for many bottom dwelling crabs and fish. Hayes⁹ who also conducted experiments in the same area noted that the mines they used reacted in much the same manner; no movement could be detected nor was there any appreciable scour after equilibrium had been reached even though surface currents as high as 3 knots were measured. Of interest is the decrease in strength of the echo from the mine used as a target after a period of 5 months. The target strength of the mine had decreased to such an extent that it could not be detected until extensive organic growth on the mine had been removed.

In the La Jolla Bay area, Mills and Jackson⁸ placed two mines on the bottom, one in 29 feet and the other in 72 feet of water. The bottom sediment in this area is a fine sand which is subject to considerable oscillatory current action. Only one observation was made on the deep mine, 4 days after the initial placement. At that time it had scoured into the bottom 8 inches (one-third of its diameter) and was lying in a shallow trough. Active scour was taking place even though the bottom oscillatory currents were only 9.4 cm per sec (0.18 knot). A thin veneer of fine sand $\frac{1}{8}$ inch thick rested on the mine. Unfortunately, this mine was never found again, due to the loss of the surface marker buoy and inability to relocate exactly over the position of placement.

The shallow mine (29 feet deep) gradually sank into the bottom until, after a period of 27 days, it was completely buried. The mine was relocated by a marker buoy on successive dives even after burial. Mills and Jackson state that, after burial, "there was no hump or other deformation of the bottom around the mine, nor was there any discontinuity of the ripple marks." The depth of burial below the sea floor was 6 to 7 inches. There was no appreciable movement of the inshore mine even though it was subject to considerable oscillatory current prior to its complete burial. To check whether or not there was any change of the general level of the bottom, Mills and Jackson placed three stakes near the mine and carefully measured the distance from the top of the stake to the level of the sea floor over a period of two months (25 June 1952 to 25 August 1952). Over this period there was no appreciable change in the sediment level.

Inman¹⁰ has done considerable unpublished work in La Jolla Bay. He found that mines became completely buried in the bottom, at a depth of 70 feet of water, if given sufficient time. He also found that, in deeper water, mines periodically became covered and uncovered, so long as some part of the mine remained above the general sea floor surface. Once completely buried, however, the mine no longer became uncovered unless the general sediment level changed. The probability of the sediment level changing is highly remote. In all studies either by Inman or the writer there has been no indication that the general surface of the sea floor beyond the surf zone on flat sand bottoms varies over 2 inches from year to year in the region of Southern California.

choice of an area

The area (fig. 1) off Mission Beach, California, was chosen as the site for this study because it was believed to represent best the general bottom conditions which prevail in sand environments near San Diego. This belief is based on over two thousand dives made by the writer between Point Conception and the Mexican border along the Southern California coast. In the Mission Beach area are found most of the elements which are featured in the sand environment in other areas. The swell and currents affecting the bottom are not modified by topographical irregularities and, therefore, afford a good picture of the changes that take place in a relatively simple oceanographic province.

The area was readily accessible to small boat operations, a necessity in carrying out long-term diving operations.

the mission beach area environment

GEOLOGY

Horizontal Sediment Distribution

There are two major sediment types in the Mission Beach area. From the shore line to a depth of approximately 60 feet, the bottom sediment is a fine-grained gray sand. It is well sorted and has a median grain diameter of 0.09 mm. Ripple marks are usually found in this area with wavelengths of 3 to 4 inches and heights of $\frac{1}{4}$ to $\frac{1}{2}$ inch. In all instances the ripples reflect the direction of swell approach in the area and are aligned perpendicular to the major oscillatory current direction. In water less than 30 feet, small channels are commonly observed to run perpendicular to the shore line; they contain slightly coarser sediment and larger ripples. These channels are the result of high current action at the heads of rip currents. Often, during periods of confused cross swell (swell arriving in the area from two different directions), a ripple pattern forms which is diamond shaped. This relationship of bottom ripples to swell is significant in that it permits the determination of general direction of swell approach by observing the ripples on the bottom. During periods of high swell the ripples in the fine sand are regenerated twice with the passing of each swell. As each swell passes overhead the sediment on the bottom is placed in motion, first in an offshore direction and then toward shore. The ripples thus formed are asymmetrical; their regeneration with the passing of each wave shows that bottom oscillatory currents exceed the critical velocity of this sediment grain size. Because these ripples form straight lines on the bottom they make an excellent navigational aid for the underwater investigator as he swims over the bottom.

Seaward of the fine sand there is a coarse-to-medium-grained, well sorted brown sand with a median grain size of 0.31 mm. Probably, this sand is a relict sediment and represents an environment of deposition different from the one that now exists in the area. It has remained through time without substantial change, because there are no agencies to cause its removal nor has sufficient later deposition occurred to cover it. The contact between these two sediments is quite sharp and often takes place over a distance of less than 12 inches. The bottom microtopography in this coarse sediment is entirely different from that in the fine sand. The ripple marks when well developed are extremely large and have wavelengths as

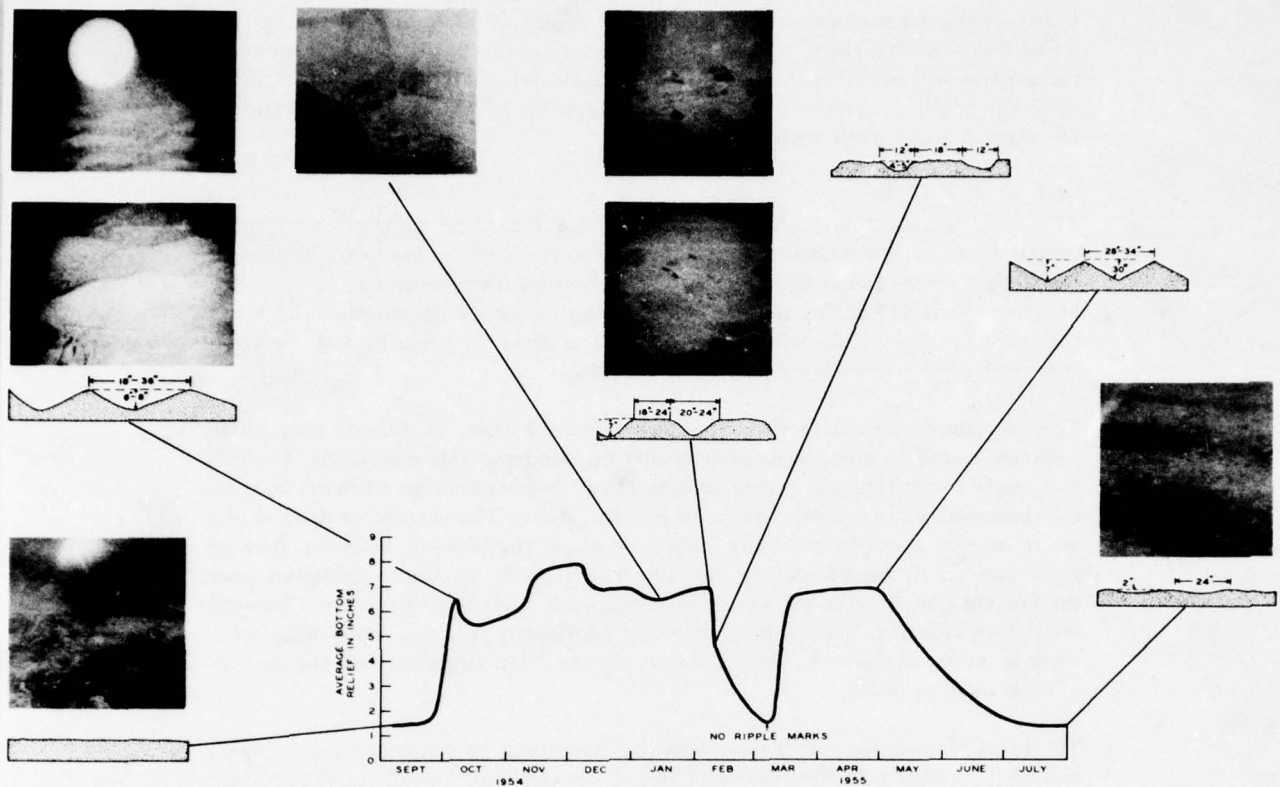

Figure 2. Cyclic behavior of the giant ripple marks in the coarse sand off Mission Beach. The profiles are of typical ripple marks.

long as 40 inches; ripple heights have been observed as high as 8 inches, but average 6 inches when the ripples are being actively formed. Because of the periodic increase in bottom oscillatory current velocity during storm-induced swell, there is a cyclic build-up and decay of these "giant ripple marks" (fig. 2), for only high-velocity bottom currents are able to maintain these large ripples. During periods of quiescence they are gradually broken down both by the weak swell-induced current action along the bottom and by the activity of organisms. The bottom micro-relief during these quiet periods, if given sufficient time to progress to an end point, will completely disappear, and the bottom will return to essentially a flat plane.

Vertical Sediment Distribution

To determine the vertical sediment distribution in the test area six jet borings were made on both sides of the contact between the fine-grained sand and the coarse-to-medium-grained sand. The technique employed a diver holding a 12-foot long, 1/2-inch diameter pipe, perpendicular to the sea floor. The upper end of the pipe was attached to a hose which ran up to a high pressure displacement pump in the tending boat. As water was pumped through the pipe, the end which

rested on the sea floor penetrated the bottom as the sediment around the tip was jettied away. With a little experience the diver could tell by the feel and sound of the pipe as it moves down through the sediment whether the pipe was striking sand, silt, cobbles, or rock. The resulting profiles (fig. 3) indicate an interfingering of coarse and fine sands with depth.

OCEANOGRAPHY

The water masses found offshore from Mission Beach are predominantly of a coastal type having a nearly constant salinity of 33.4⁰/₀₀ and temperatures at the surface which range from 49°F to 74°F. Bottom temperatures as low as 48°F have been recorded during periods of upwelling in the spring months. The water transparency is variable with visibilities for a diver in a horizontal direction ranging from less than 6 inches to over 50 feet.

The longshore currents in the area rarely exceed 1 knot; in general they range between 1/4 and 1/8 knot, depending greatly on wind and tide conditions. There is frequently a sharp change in current strength at the thermocline. Currents beneath the thermocline are usually weaker than those above. The current or drift of the water mass as a whole is usually very slow along the bottom; however, passing swell sets up strong oscillatory currents which reach maximum velocities near the breaker line. Most of the scour observed in this study was due to swell induced oscillatory currents. The pattern of water movement beneath the passing of a wave is shown in figure 4. These currents reverse their direction with the passing of each wave or swell.

To obtain meaningful values for use in the determination of competence to move sediment (critical velocity), the velocities of the oscillatory bottom currents were (1) calculated from surface wavelengths and periods (Munk and Sargent¹¹) and (2) measured directly *in situ* by using dye to mark a particular water mass and timing its movement with relation to a fixed reference point on the bottom. The computed velocities, although lower, compared favorably with those measured. Typically, a computed value for a given set of data would be 0.6 knot whereas measured velocity would be 0.72 knot.

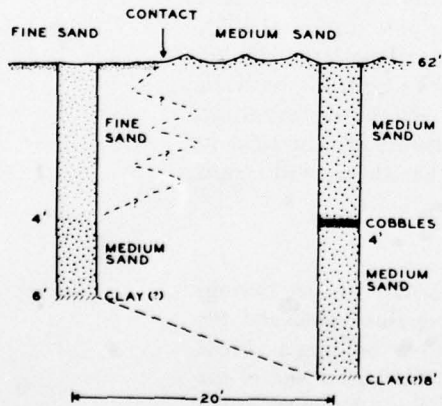

Figure 3. Jet coring profiles of the sediment on both sides of the contact between fine and medium sand in the Mission Beach Test Area.

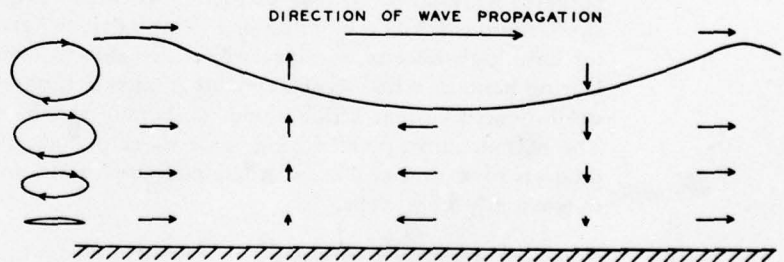

Figure 4. General characteristics of oscillatory currents in shallow water showing direction of water particle movement with the passage of a wave.

field methods

PLACEMENT OF MINES

The initial position for a mine was determined by means of a predetermined range set up on the shore. After the ship reached water of the proper depth, the mine was dropped over the side and the position of the mine determined with horizontal sextant angles from known points on the beach. The mine was also marked visually on the surface by a small buoy attached to the mine by a line. The line had very little scope and the buoy indicated the position of the mine on the bottom to within 10 feet.

Dummy plaster-filled mines were used as test objects and were placed on the bottom from a modified LCU by dropping them freely from the sea surface to the bottom. The mines made a slow spiral descent to the bottom with their maximum axis parallel to the sea surface. There was no appreciable digging in or formation of a mound of displaced sediment when they hit the bottom.

There was no indication that the mines struck the bottom with any preferred orientation. It is unlikely that there was sufficient time during the fall to allow any orientation with regard to swell or current.

The initial observation of the mines by project personnel was made within minutes after their placement; during these few minutes the mine had already begun to create a scour depression. The mines were rolled out of their initial depressions and oriented by the divers parallel to the main ripple mark trend. This reorientation placed the largest area of the mine perpendicular to the direction of the prevailing bottom oscillatory currents and insured that maximum scour would take place. It also insured that the starting position of the mine would be the level of the sea floor at the beginning of the tests.

MEASUREMENT OF SCOUR

Four-foot stakes were driven 2 feet into the sea floor around the mines in a predetermined pattern (fig. 5). This pattern enabled the SCUBA-equipped geologists

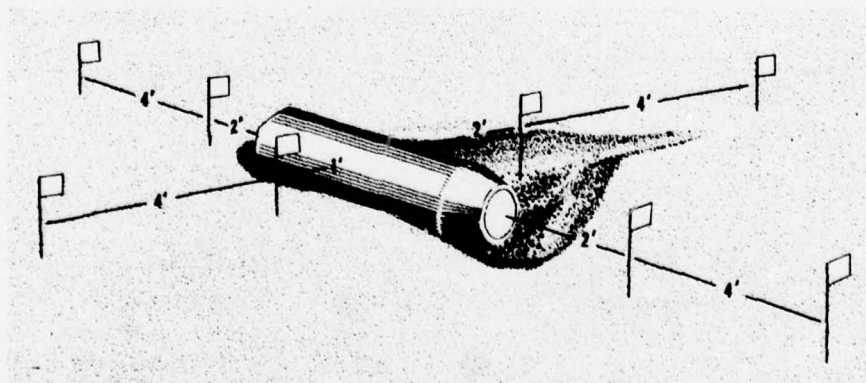
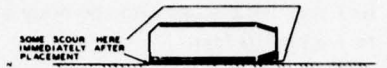

Figure 5. The arrangement of the measuring stakes used to determine the amount of scour around mines.

CONFIDENTIAL

to make measurements of changes in sand level and movements of the mine from given reference points, as the mines scoured into the bottom. Contours of the scour depressions based on these measurements are shown in figures 6 and 7. The stakes were of small diameter and did not themselves create scour patterns; thus the measurements of changes in bottom level are probably accurate to within 1 inch.

Figure 6. Scour depression over a period of time around a mine in 30 feet of water.



FEBRUARY 21, 1955

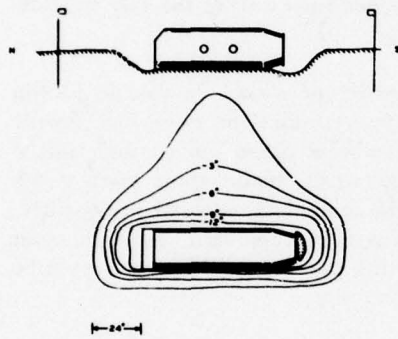

FEBRUARY 24, 1955
3 DAYS

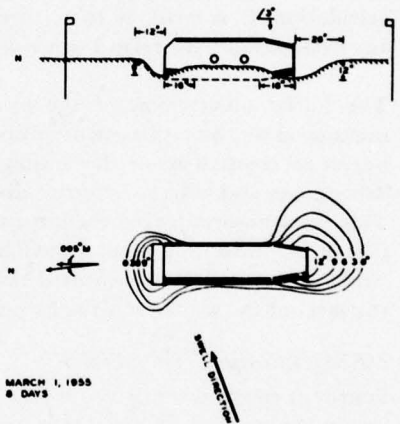

MARCH 1, 1955
8 DAYS

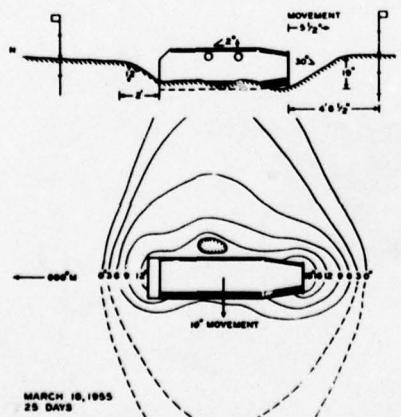

MARCH 18, 1955
25 DAYS

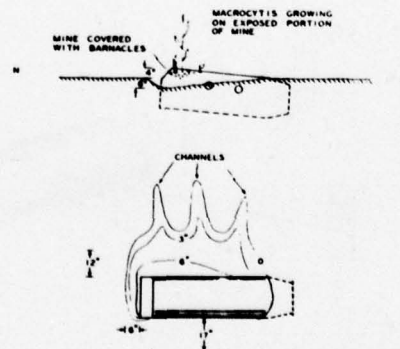

OCTOBER 4, 1955
7 MONTHS

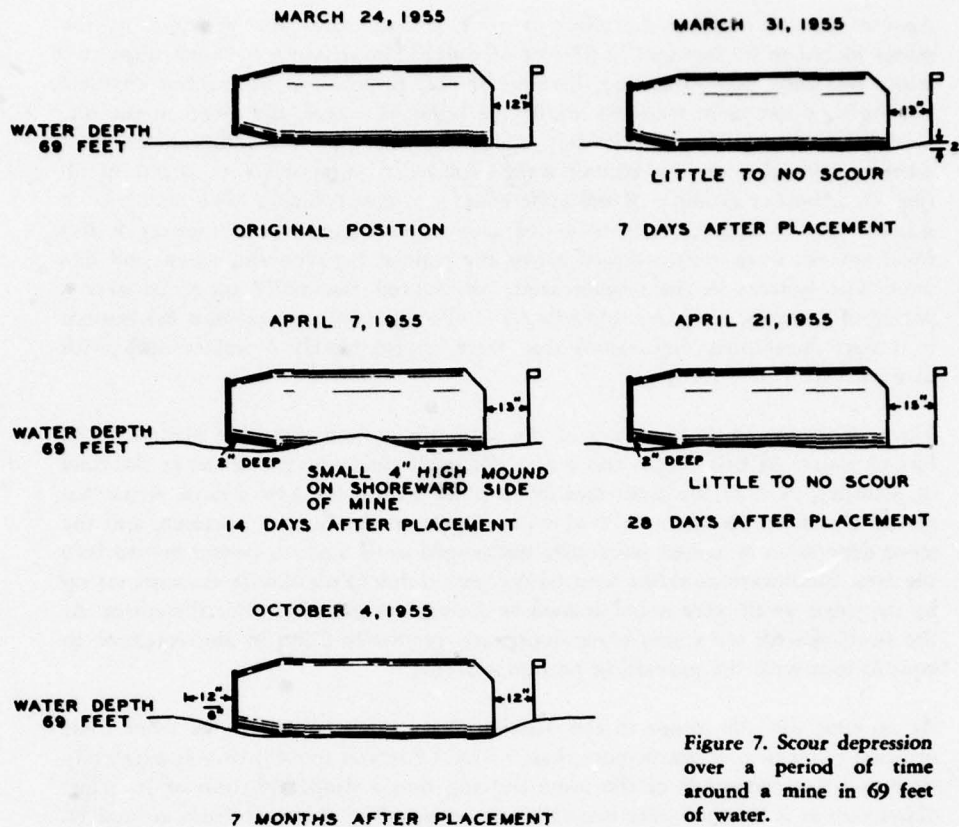

Figure 7. Scour depression over a period of time around a mine in 69 feet of water.

Any movement of the mine horizontally (and its direction), with reference to the stake, was measured. Sketches of the scour depressions were made by divers while on the bottom. The actual depth of sinking was measured by placing a leveled steel rod on one edge of the scour depression, extending it to the mine and making a scratch on the mine. The scratch thus showed the level of the sea floor relative to the mine at the time of measurement. Successive scratches were used to determine the rate and amount of scour into the bottom. All horizontal movement of mines in the Mission Beach area took place within the pattern of the nearest stakes (fig. 5).

field observations

OBSERVATIONS OF MARK 36 MINES

Mines were placed in depths of water ranging from 30 feet to 69 feet. Scour started as soon as the mines were placed on the bottom, except in the case of the outermost mine (planted at 69 feet) which was on the medium-grained sand. Bottom currents were not sufficiently strong at this location to move these larger sand grains.

An excellent example of the effect of grain size on scour was provided by the mines placed in 69 feet and in 63 feet of water. The distance between these two mines was only 100 yards and, because of this proximity, the bottom currents impinging upon them were essentially the same. However, the mine on the fine sand bottom scoured approximately one-half of its diameter into the sediment whereas the mine on the coarser sand experienced practically no scour at all (fig. 8). (Another example of the same effect was noted during experiments with spheres used as acoustic targets in the same area. Eight 2-foot diameter water-filled spheres were evenly spaced across the contact between the coarse and fine sand. The spheres in the coarser sand experienced essentially no scour over a period of 2 weeks. However, the spheres in the fine sand scoured into the bottom in 1 day, developing depressions that were approximately 8 inches deep with diameters of 4 to 5 feet.)

Figure 6 shows the development of the scour pit around the mine planted in 30 feet of water. At this depth, and under the swell condition prevalent at the time of planting, most of the scour had taken place within the first 4 days. After this period the mine became stabilized with respect to the bottom currents, and the scour depression remained essentially unchanged until a storm system moved into the area. Modifications of the scoured depression due to oscillatory currents set up by the storm swell were noted as soon as diving was practical after the storm. As the swell abated, the storm scour depression gradually filled in and returned to equilibrium with the prevailing bottom currents.

At no time did the mines in the Mission Beach area roll or move from their original point of placement more than 1 foot. Observed movement was extremely slow and was the result of the mine shifting into a deeper portion of its scour depression as it became undermined by the removal of sediment from around its base. The inshore mines scoured in faster than those in deeper water.

Associated with the development of the scour depression was a definite coarsening of the sediment in the immediate vicinity of the mine. Coarse residual material such as shell fragments and pebbles was left as a lag deposit after the fine sediment,

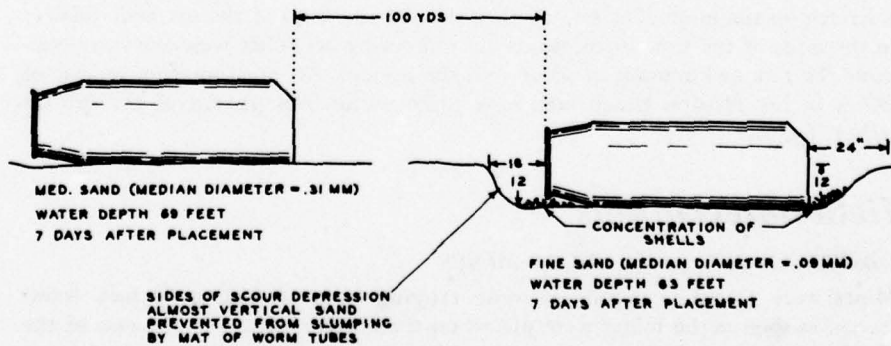

Figure 8. Relative rates of scour for mines subject to nearly the same oceanographic conditions when one is on a fine sand bottom and the other on a medium sand bottom.

which ordinarily surrounded the mine, had been scoured away. Bottom currents were not sufficiently strong to move this coarse material, and it accumulated in the deepest portions of the scour pit (fig. 9).



Figure 9. A scour depression at the nose of a mine showing the coarse material that collects as a lag deposit.

THE EFFECT OF SHAPE

In addition to placing dummy mines on the sea floor a series of free-floating shaped objects were placed on the bottom for observation. Two cylinders, a hemisphere, a hemi-oblate spheroid, and a cylinder with a circular base plate attached to one end were used (fig. 10). The purpose of this part of the study was to determine what shapes are most affected by bottom oscillatory currents.

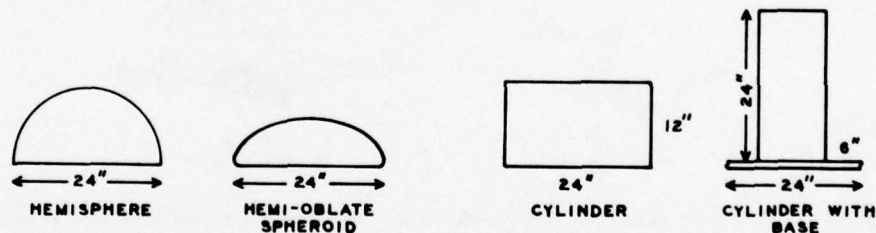

Figure 10. Shapes and sizes of the various objects used to determine the effect of shape on scour.

Figure 11 shows the scour and relative movement of the hemi-oblate spheroid. This object weighed 35 pounds in air and approximately 25 pounds in water. When placed flat side down on the bottom in 30 feet of water, it had a tendency to sail upcurrent. The shape of the object actually appeared to give it a hydrodynamic lift as the currents moved over it. This lift caused the object to topple into its scour depression. Tilting of the object was observed almost as soon as a scour depression developed.

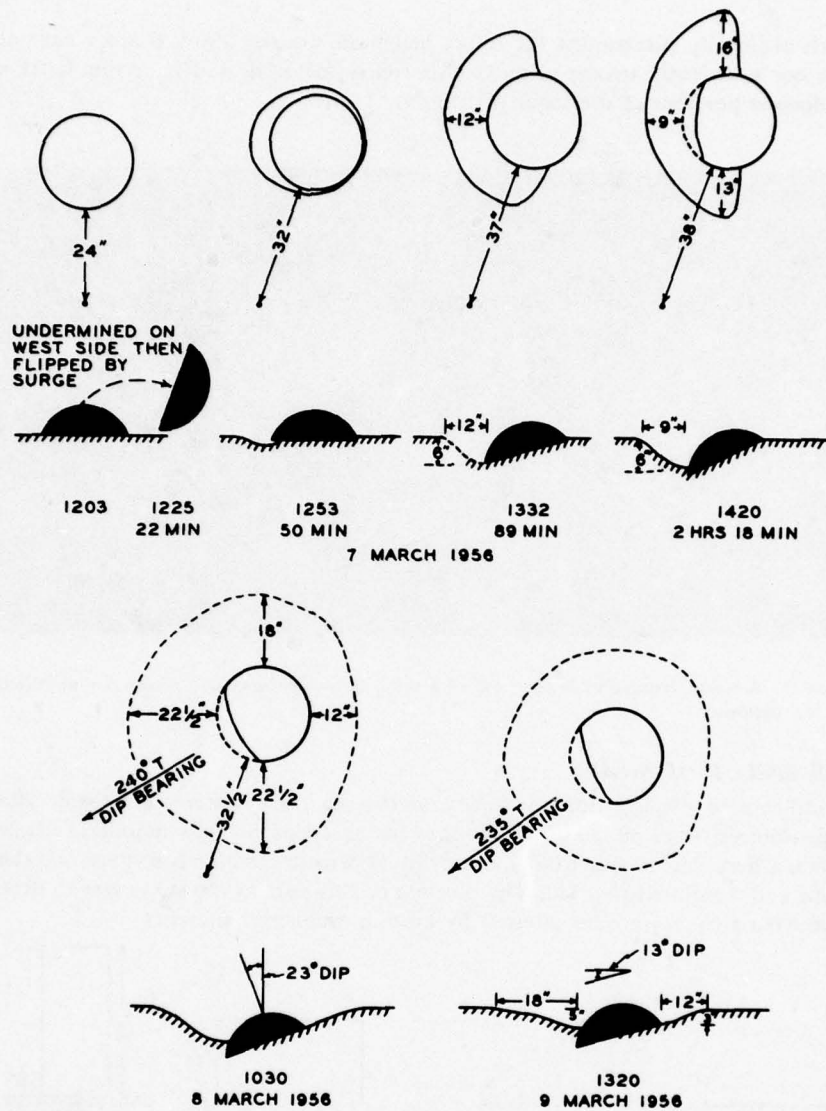

Figure 11. The scour depression and movement of a hemi-oblate spheroid with time in 30 feet of water.

The hemisphere, which had a diameter of 24 inches and a weight of approximately 35 pounds in air (25 pounds in water) was quite stable when placed in 30 feet of water even though a scour depression began developing immediately after the object was placed on the bottom (fig. 12). Little to no tipping was associated with this shape. The motion of the clouds of sediment caused by the turbulence around this object closely resembled the eddy motion commonly observed in wind tunnel experiments with spheres. The scour depression was asymmetrically shaped and better developed on the shoreward side of the hemisphere, probably because the onshore phase of the oscillatory current was stronger than the offshore phase.

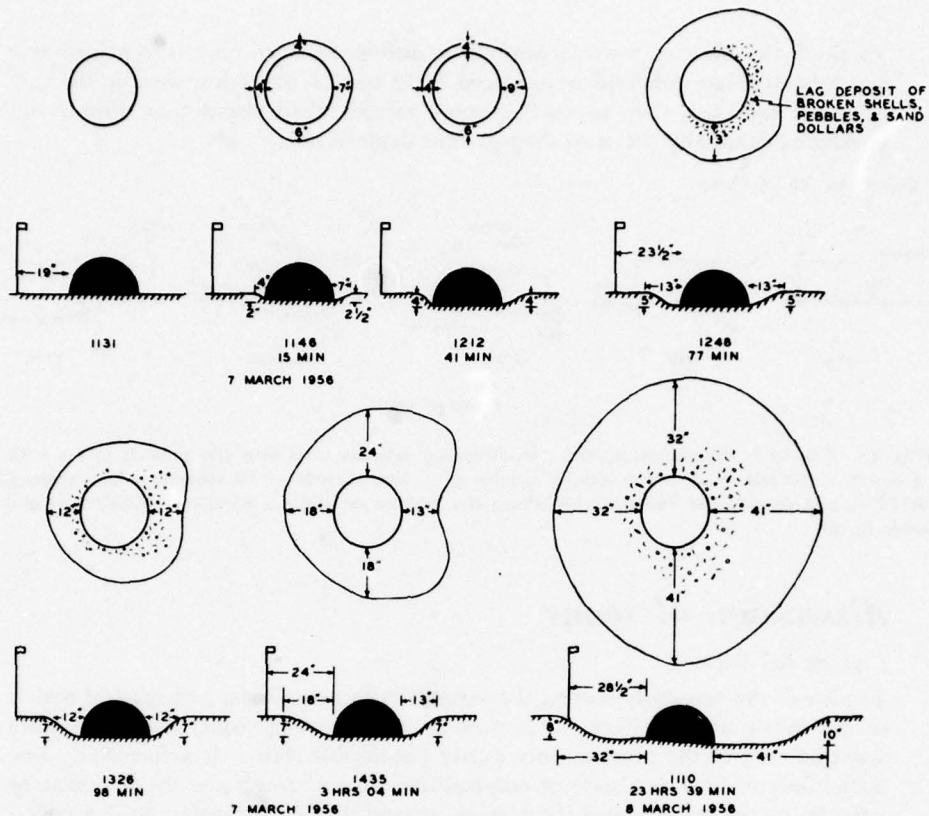

Figure 12. The scour depression and movement of a hemisphere with time in 30 feet of water.

Free-flooding cylinders of two different weights but the same size (2 feet long and 12 inches in diameter) were used in the experiment; one weighed 37 pounds in air and the other 100 pounds. The lighter cylinder rolled along the sea floor when first placed on the bottom. It moved both seaward and shoreward with the passage of each swell, and covered a distance of 125 feet before it finally became almost immobilized by the formation of a scour depression. At this point it began to scour into the bottom, still moving slightly however, and over a period of two days made a trench in the bottom 7 feet long and 7 inches deep.

The heavy cylinder was weighted internally. When placed on the bottom it did not roll, as did the light cylinder, but immediately set up a scour pattern and rapidly scoured into the bottom. It had a tendency to tip as scour developed (fig. 13). However, like the larger mines, it reached equilibrium with the prevailing currents within a short time, in this case 1 day.

The cylinder with a circular base plate attached to one end soon after placement (standing on its base plate) toppled over and excavated a very large scour pit in the bottom. It moved from one side of the scour depression to the other with the passing swell, and within 20 hours it was 1½ feet deep into the bottom in a depression that was 6 feet in diameter.

To check the effect of water depth on the different shaped objects, a hemisphere and a hemi-oblate spheroid were placed in 12 feet of water just outside the surf zone. As expected, they scoured in more rapidly than the deeper objects but developed essentially the same shaped scour depression.

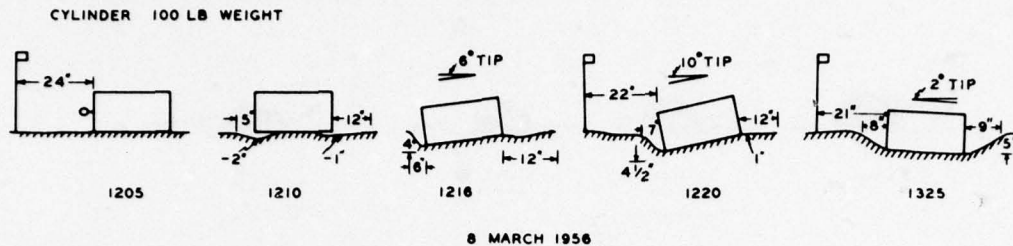

Figure 13. The scour depression around a free-floating cylinder weighing 100 pounds in air with time, at a depth of 30 feet, with swells having heights of 4 feet, periods of 10 seconds, and wavelengths of 150-175 feet. This cylinder did not roll along the bottom as did an identical cylinder weighing 35 pounds in air.

discussion of scour

CAUSE OF SCOUR

Because of the transitory nature, the variability in magnitude, and spectral nature of the swells which induce the bottom currents causing scour, their effects are unstable and, at the present, only partly predictable. Scour is a factor in mine burial only as long as a state of non-equilibrium exists between the sedimentary particles on the sea floor and the currents around the object causing local accelerations. As previously mentioned, the main variables controlling scour formation are the sediment grain size, current velocity, and the shape of the object relative to the general surface of the sea floor.

In general, all current or water motion in the ocean is in a turbulent state.¹² Therefore, when considering the bottom currents, at a given point either before or after scour takes place, one has to consider velocity distributions. In turbulent flow, the random motions of small masses of fluid are superimposed upon some simple pattern of flow. The instantaneous velocity distribution during turbulent flow is difficult to determine, since current meters give a time-averaged value. The instantaneous velocity is the sum of this average velocity and the random velocity.

The time distribution of the instantaneous velocities is important when considering the cause of scour. In many instances in nature, especially if the bottom currents are in near-equilibrium with the critical velocity of the sediment, the average current velocity theoretically is not large enough to cause movement of sediment, but sediment motion and scour nevertheless occur. Movement is especially noticeable on the crests of ripple marks. This movement can be explained by high-instantaneous-velocity currents on the upper end of the velocity distribution curve, which may occur when the random current is in the same direction as the average flow current. If the instantaneous velocity is large enough to surpass the critical velocity of the sediment, sediment movement and possibly scour will take place.

The concept of critical velocity needs more explanation. Because of the turbulent flow of water in nature and the variation of grain size in naturally occurring sediments, there is no specific current velocity at which all sediment of a range of grain size classified as sand will move. However, for a sediment of given range of grain size, the probability of movement increases with the instantaneous velocity and builds up rapidly in the neighborhood of the critical velocity. The movement is a grain-by-grain process, with individual particles being lifted or pushed along the bottom by small masses of turbulently moving water. Therefore, critical velocity may be defined practically as the minimum current velocity which will cause recognizable movement of the sediment present on the sea floor in any given area. Hjulstrom¹³ has computed the current velocities necessary for movement of sediments of various grain sizes. The values were based on data gathered in the laboratory, but are extremely useful for field problems, because they appear to be valid when applied to sediments found in nature. The critical velocities used in this report for the Mission Beach sediments are derived from Hjulstrom's curve.

In turbulent flow over the bottom, if one assumes a Gaussian distribution with zero mean for the horizontal components of the random currents, the typical bell-shaped curve, as shown in figure 14A, will probably represent the current regime at that time. (There will also be a vertical component to the current but, near the bottom in the depth of water in which this study was made, it is insignificant and it is not considered in the present discussion.) Observations of the sea floor in most areas usually show very little movement of bottom sediment by current beyond the formation of ripple marks. This usual lack of movement leads to the conclusion that the bottom sediments have a higher critical velocity than the prevailing current velocity of the area and are, in general, in equilibrium with the prevailing swell conditions.

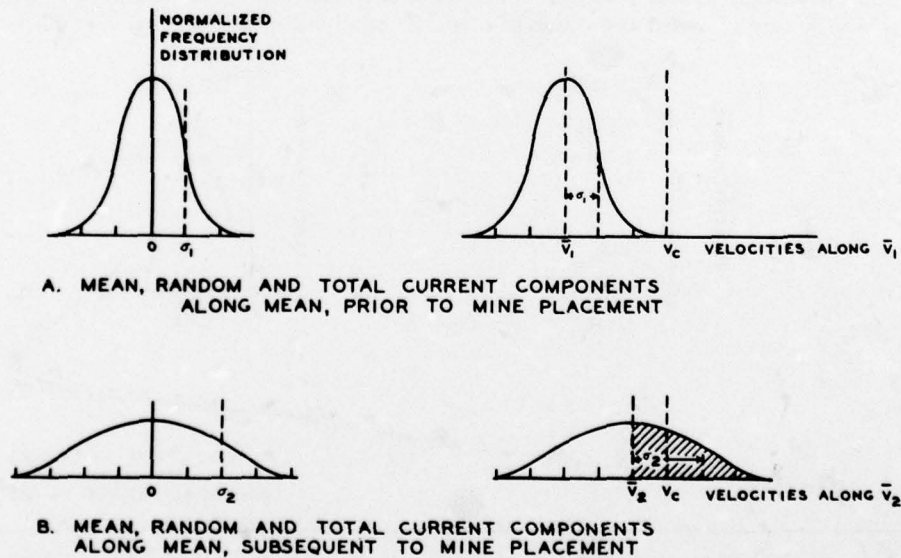

Figure 14. Normalized random velocity distribution for currents before and after placement of the mine.

When an object, such as a mine, is placed on the bottom the existing velocity distribution in the near vicinity of the mine is upset. Streamlines of water flowing about the mine converge, resulting in an increase in mean flow velocity in areas at the ends of the mine. This increase in the mean flow may now result in some of the total velocities exceeding the critical velocity. In addition, in the presence of a boundary or obstruction, the turbulence generally increases when the mean flow increases, resulting in a broadening of the random velocity distribution curves in a particular water mass. This would mean that the critical velocity would not only be exceeded by the generated higher velocity currents, but also that the sediment would be subject to them for an even greater per cent of the time (fig. 14). This effect accounts in part for the relatively higher rate of scour around the ends of the mine cases observed in this study.

EFFECT OF DEPTH ON SCOUR PRODUCING CURRENTS

The oscillatory currents which are the main cause of scour in the Mission Beach area decrease in velocity with increasing depth of water and approach a general flat back-and-forth motion as the bottom is approached (fig. 4). It is therefore to be expected, and was found, that the amount and rate of scour around mines decrease with depth and distance from shore. By using the mean wave height and period of waves which are found in Mission Beach (Carsola, *et al.*¹⁴), the maximum bottom current velocity generated by the passing of this mean wave can theoretically be computed by the following equation:

$$\mu = \frac{\pi H}{T} \cdot \frac{1}{\sinh 2 \frac{2\pi b}{L}}$$

where μ is the maximum velocity along the bottom in a horizontal direction, H the wave height, T the period of the wave, L the wavelength, and b the depth of water. Figure 15 shows the values of μ and its relationship to the critical velocity

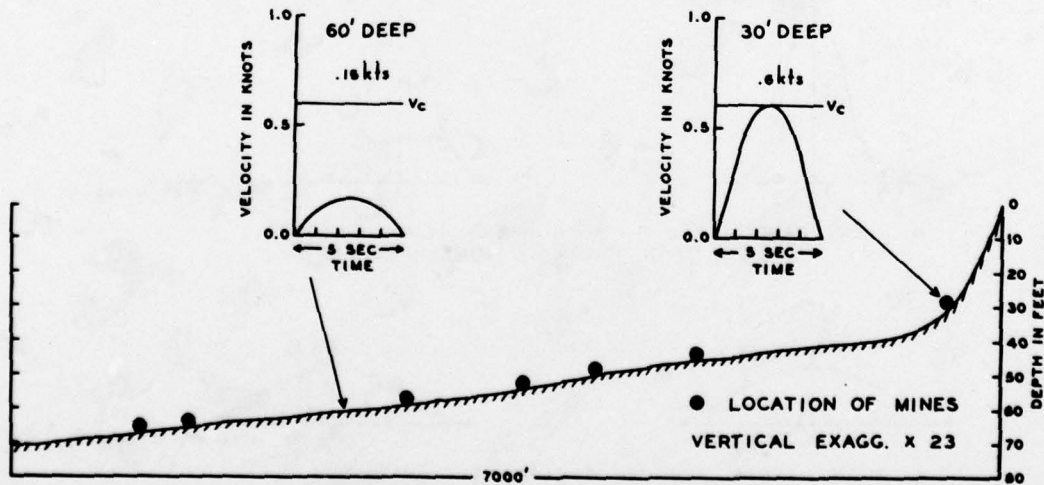

Figure 15. Bottom profile off Mission Beach, California, showing location of test mines and their relationship to bottom currents set up by the average swell. V_c is the theoretical critical velocity for the sediment found in this area.

at two depths for a typical wave in the Mission Beach area. For this example, a wave was chosen to represent the mean wave over a period of 9 months. This typical wave has a wavelength of 210 feet, a height of 2.4 feet, and a period of 10 seconds in 60 feet of water; it has a measured wavelength of 180 feet, a period of 10 seconds, and a height of 4 feet in 30 feet of water. It was assumed that this wave has a sinusoidal shape. Although this example is theoretical, mean values of wave period were used, and the computed velocities are probably a fair estimate of the mean of the prevailing conditions in the Mission Beach area. It should be added that these values agree with the current measurements made directly on the bottom by underwater observers during times when swell in the area was close to the mean used in the calculations.

The bottom profile in figure 15 has a sharp break-in-slope at a depth of approximately 40 feet. In this general area the bottom oscillatory velocities for the mean wave conditions surpass the critical velocity of the bottom sediments. At depths greater than this break the average currents are not capable of moving the sediment. It is to be expected, therefore, that at this depth there would be a sharp decrease in the amount of sediment transported along the bottom. Fisher (personal communication)¹⁵ found in sediment trap experiments off La Jolla Bay that there is a distinct change in the amount of sediment which is transported along the near shore areas at the break-in-slope of the bottom profile. His work was done in an area with wave conditions similar to those in the Mission Beach Test Area.

In deeper water, there is no continuous agency of burial except organisms which slowly plow sediment into storm created scour depressions. There are, therefore, long periods of time between storms when there is no competent current agency which will cause rapid burial of objects on the bottom. Therefore, for all practical purposes there is a "depth of non-burial" in most areas subject to oscillatory currents. The part which organisms play in returning irregularities of microtopography to a flat plane in deeper water is therefore extremely important.

In the Mission Beach Test Area the swell conditions were usually constant for periods of at least several weeks. This resulted in the bottom sediments reaching equilibrium with the oscillatory currents around the mines in stages. During most observations bottom conditions were constant and, after the initial scour period, few changes took place in the scour depression around the mine for considerable periods of time. However, during the occasional storms which passed through this area, the bottom oscillatory currents were intensified and bottom sediments were set into motion by mine induced turbulence. During these storm conditions the scour depressions grew in size and depth, causing the mine to sink deeper into the bottom. When the storm currents abated there was a return to equilibrium and the scour pit was gradually filled in by minor current actions and organisms until the mine was again able to exert sufficient influence on the new set of oscillatory currents to maintain a depression.

Storms, therefore, tend to deepen the scour hole and cause the mine to sink into the sediment to a greater depth than it could attain by normal scour action during periods of equilibrium. Also, when the scour pit is filled in after the storm currents diminish, the mine case causes less turbulence because less of its area is exposed to the oscillatory currents. The decreased obstruction therefore cannot

maintain as large a scour depression, and the depression becomes smaller after storms. Thus, the following step-like sequence occurs in the burial of a mine on sand bottom: (1) a rapid scour over a relatively large area of the bottom around the mine when it is first placed on the sea floor; (2) a period of nonscour which continues so long as an equilibrium exists between the turbulent currents created by the mine and the sediment, during which period the depression neither grows nor diminishes; (3) the increase in size and depth of the scour depression with occasional storms; and (4) the subsequent return of the scour depression to equilibrium with relatively low velocity bottom currents prevalent in the area.

The change of equilibrium and the filling and scour around the mine are also responsible for the coarsening of the bottom sediment around ground mines with time. During the period of high velocity oscillatory currents caused by storms, the finer fractions of the bottom sediment are removed from the vicinity of the mine. Only material of sufficient size to resist movement by these currents remains. Therefore, as most naturally occurring sediments are a mixture of particles of different grain size, as time passes, there is left around the mine a lag deposit of only the coarsest fraction of the original sediment. Usually this fraction consists of shell fragments, cobbles, and debris such as cans and bottles. In addition to the coarse material there is often a collection of kelp and other seaweeds which drift into the area and settle in the scour depression after bottom currents have become weak.

Because of the oscillatory nature of bottom currents, the water particles must go from essentially a still position to a maximum velocity and return to a still position with the passing of each wave. This periodic variation in current velocity is important in the process of scour because, in many instances, depending on the water depth, there is only a short time during the passage of each wave when the critical velocity is surpassed and scour can take place.

The velocity of bottom water particles plotted against time at various depths, as a theoretical sinusoidal surface wave with a 10-second period passes through an area, is shown in figure 16. The numbers shown in these curves are only a rough

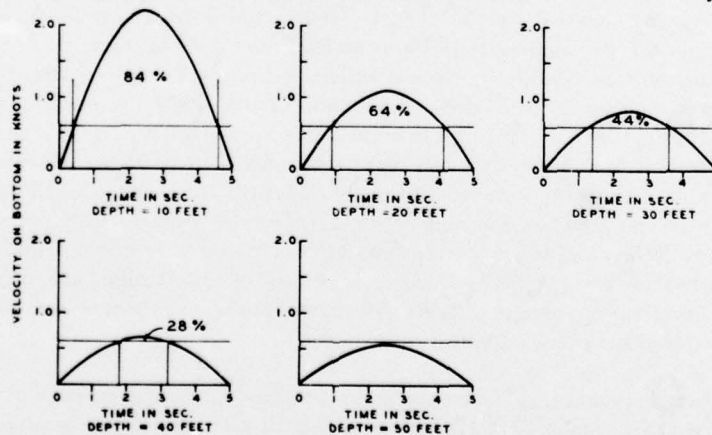
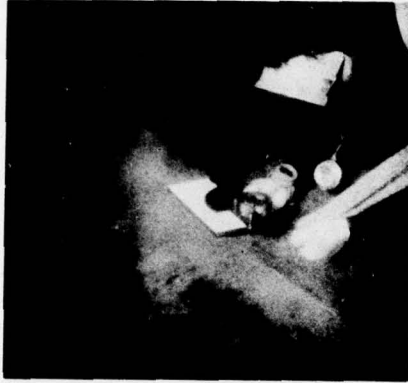

Figure 16. The percentage of time that the critical velocity is exceeded by bottom currents during the passage of a theoretical wave from deep to shallow water over an area like Mission Beach, California. The critical velocity used in this example is 0.6 kt.

approximation of the actual current velocities, because the theory upon which they are based does not take in account the variability and spectral nature of naturally occurring waves in shallow water. They do, however, show that mines placed in shallow water will not only be subject to higher current velocities but also will be affected for longer times than mines placed in deep water.



A. MEASURING THE TREND OF GIANT RIPPLE MARKS



B. SOUND REFLECTING SPHERE IN THE TROUGH BETWEEN GIANT RIPPLE MARKS



C. MEASURING THE ANGLE OF SLOPE WITH AN INCLINOMETER



D. MEASURING THE WAVELENGTH OF GIANT RIPPLE MARKS

Figure 17. Giant ripple marks as they appear in the Mission Beach Area.

the stabilization of mines

EFFECT OF GIANT RIPPLE MARKS

As previously mentioned, in sediment of medium-to-coarse-grain size, giant ripple marks form (fig. 17). In the Mission Beach coarse and medium sands, these ripples have heights of up to 8 inches and wave length up to 40 inches. On the sea floor

they form elongated relatively symmetrical sharp crested ridges, parallel to the general direction of surface wave crests. In general, high current velocities are needed to produce these features, and when the currents which produced them decrease, the ripples gradually decay and the bottom returns to a flat plane. Placing a mine in such an area can be likened to placing a dowel on a washboard. If the mine is to move, it must be lifted over a series of 6-inch to 8-inch high ridges. Currents of the velocity necessary for such a lifting force would create extreme turbulence around a mine case and scour would occur. This scour would form a large pit from which it would be impossible for the mine to roll. Never, in any of the sand environments visited during this study, have bottom currents reached sufficient velocity to move a mine along a coarse sand bottom.

BIOLOGICAL CHANGES

Underwater observations have shown that, whenever a mine or any other sizable object is placed on a sand bottom like that found off Mission Beach, a foreign biotope* is created which attracts organisms not normally found in the area surrounding the mine. Foreign objects also act as anchoring points for sessile (attached) organisms and plants which would normally be swept from the area by currents. Thus, with the passage of time a population foreign to the area develops around a mine.

Fish, such as pile perch and blennies, congregated around the mines in the Mission Beach area and used them as hiding places. Many bottom crustaceans, such as crabs and lobsters, also used the mine case as a home. Octopi were frequently observed under mines, as were many different types of shrimp. Barnacles, bryozoan, sponges, hydroids, and starfish are also associated with mines which have remained on the bottom for some time.

In many areas along the Pacific coast giant brown algae, *Macrocystis pyrifera*, use objects on sand bottoms as holdfasts. In the Mission Beach area and off La Jolla these plants often reach a length of 40 feet. Of particular interest are the small gas filled floats which hold the plant upright in the water (fig. 18). These floats are excellent acoustic targets. Other algae commonly use mines as anchors and will completely cover a mine if it remains in the marine environment for any period of time. Often the depth of burial of a mine during a previous cycle of burial can be determined by observing the line of demarcation between the organic growth on a mine and that portion which is clean of growth.

Scour on a sand bottom is also affected by the organic mats which are formed by worms and plants (fig. 19). In some places on the bottom of the Mission Beach area these mats are quite dense and form areas resistant to scour, as was indicated when spheres were placed upon them. Sediment found in the near-vicinity of the mat is coarser than the surrounding sediment and, since it has a higher critical velocity, is more resistant to scour. In addition, the bodies of the worm tubes found in these mats extend down into the sediment and make it less susceptible to scour. These mats have been observed to extend down into the sediment for a depth of at least 2 feet. Normal slumping does not occur in areas of organic mats

* An area in which the natural conditions and the living forms are essentially uniform.



Figure 18. Gas-filled floats of *Macrocyctis*.

~~CONFIDENTIAL~~



Figure 19. Organic mat at Mission Beach which inhibits erosion.

and angles of repose for matted sand are often much greater than for corresponding sediments found on land. Extremely steep sides can be maintained in holes and scour depressions, because of reinforcement by the interwoven plant and animal bodies. An example of this effect was provided when trying to dig a hole into the bottom off Mission Beach. An air lift was used to pump sediment from the bottom into another area in the hope that, as the hole became deeper, the sediment would slump into the hole and the diver would not have to move very far from his original position as he settled into the bottom. However, the structural strength of the sediment was so great that vertical walls were formed and, in some instances, could be undercut without collapsing, due to the large numbers of organisms holding the sediment together.

conclusions

1. Scour around bottom mines is dependent on the velocity of impinging bottom currents, the surface area of the mine exposed to the current, the shape of the mine, the grain size of the bottom sediments, and the presence or absence of organisms and plants in the sediment.
2. On sand bottoms such as those found off Mission Beach, California, where the major agents of scour are the swell-induced oscillatory currents, mines scour into the bottom at higher rates in the shallower water than deeper water because bottom currents are stronger and operate over longer periods of time in shallow water. Offshore in deeper water, there is a rapid drop-off in the velocity of oscillatory currents. Because of this effect, in many areas bottom current velocities do not surpass the critical velocity of the sediment, and a depth of non-burial is reached. This depth of non-burial varies with different seasons, because of the seasonal variations in height and period of swell. In any one area a general range of swell conditions prevails, and it is possible with a few environmental measurements to predict with some accuracy the depth at which a mine will scour into the bottom. The measurements needed for such a prediction are bottom sediment size and bottom current velocity.
3. Scour is strongly dependent on sediment size. In the Mission Beach area a mine placed in fine sand scoured into the bottom one-half of its diameter, whereas a mine in medium sand only 100 yards away and subject to essentially the same currents showed no appreciable scour during the same time.
4. Scour is largely the result of the increased carrying capacity of the current in turbulent flow around any object which upsets the streamlines of flow of the bottom currents.
5. The maximum movement observed for any of the mines in this study was only a few inches relative to reference stakes placed in the bottom near the mines. This suggests that many of the large movements of bottom mines reported in the literature may be due to location errors.

6. In the Mission Beach area a cylinder which weighed 37 pounds was moved back and forth along the bottom by the oscillatory currents. A similar cylinder which weighed 100 pounds did not move but scoured rapidly into the bottom. This indicates that there is a critical weight which must be attained before an object will remain stationary for a long enough time to allow scour to take place.

7. In all the scour depressions which formed around the shaped objects, there was an appreciable coarsening of the bottom sediment. This change in bottom type, and the resultant change in acoustic reflectivity, might be utilized in finding bottomed objects by acoustic equipment.

8. Tipping is often associated with objects placed on a sand bottom, as scour depressions develop. Therefore, if an object is to remain perpendicular to the bottom of the sea, some special means must be used other than the original placement of the object on the bottom in an upright position.

9. A mine or any other object on the sea floor will scour into the bottom at variable rates, dependent on the swell conditions at the time of placement and the duration of these conditions. For example, a mine placed on the bottom during a period of extremely high orbital currents will rapidly scour itself into the bottom. If this scour continues until the top of the mine is below the general level of the sea floor it is likely that, during the next quiescent period the mine would be completely buried. Conversely, if the mine were placed on the bottom during a period of low oscillatory velocities it might remain at the surface and show very little scour for a considerable time. Usually, a series of events takes place before a mine is completely buried. When first placed on the bottom (during fast scour periods) the mine will rapidly scour into the bottom until it is below the general sea-floor surface and the exposed surface area of the mine is no longer capable of causing the necessary turbulent current velocities to further enlarge and deepen the depression. At this stage, equilibrium will be maintained as long as the currents remain constant. If the currents become weaker, the depression will gradually be filled in by slumping and the activities of organisms; if the currents become stronger, the depression will become larger and the mine will sink deeper into the bottom.

recommendations

1. The conclusions offered in this report are based on data obtained only in the area off San Diego. It is recommended that additional work be done in other areas to check the validity of extrapolating information on mine scour from one area to another.

2. The results obtained in the Mission Beach area suggest that a few simple environmental measurements would permit the prediction of mine behavior in other areas which are covered with a sand sediment. An excellent opportunity now exists to obtain these measurements during the Inshore Survey Program currently being conducted by the U. S. Navy Hydrographic Office.

3. Because of the higher rate of scour in shallow water in those areas subject to oceanic swell, it is suggested that the near-shore areas be searched first during mine hunting operations. Mines in deeper water will probably remain unburied for longer periods of time. Mines planted in shallow water may be completely buried in several days if subject to strong oscillatory or tidal currents.
4. It is extremely desirable that a navigational system be developed for mine hunting operations which will allow the rapid determination of position to within 50 feet under all weather and current conditions. One of the main difficulties encountered in the relocation over the test mines was the maintenance of a fixed position prior to diving on the mine. Operational units would face these same problems during final identification and removal of mines by diving personnel.
5. In future work on mine scour, it is recommended that the height and wavelength of surface waves be measured concurrently with the bottom oscillatory currents, to provide a better understanding of their relationships.
6. The NEL-developed AN/PQS-1(XG) diver-held sonar proved extremely useful in finding mines during portions of this study. It is recommended that this type of equipment be made available to Navy mine hunting units as soon as possible.

references

1. Shepard, F. P., *Percentage of Continental Shelf Covered by Sand*. Personal communication, Scripps Institution of Oceanography, 1956.
2. Commander Mine Squadron FIVE (CTG 59.2) CONFIDENTIAL letter serial 0272 to Commander Mine Force, U. S. Pacific Fleet, Subject: *Letter Report on Mine Hunting Operations*, 2 December 1953.
3. Woods Hole Oceanographic Institution, *Behavior of Scale Models of Mark 25 and Mark 12 Mines in a Flume*, by G. D. Kellogg, Jr., and K. C. Reynolds, CONFIDENTIAL, 15 March 1946.
4. Woods Hole Oceanographic Institution, *Survey of Oceanographic Conditions in Areas of Provincetown, Massachusetts, Restricted for U. S. Naval Mine Test Facilities*, by H. C. Stetson and J. L. Hough, 15 March 1946.
5. Narragansett Marine Laboratory Reference 54-13, *An Evaluation of Mine Behavior Observations in Four Test Areas*, by J. J. Donohue and L. E. Garrison, CONFIDENTIAL, August 1954.
6. Narragansett Marine Laboratory Reference 55-15, *Marine Sedimentation Project; Mine Behavior Studies*, by R. L. McMaster and others, p. 1-37, SECRET, December 1955.
7. Narragansett Marine Laboratory Reference 55-16, *Marine Sedimentation Project; Geological and Engineering Characteristics at Mine Behavior Test Sites*, by D. E. Frazier and C. E. Miller, CONFIDENTIAL, December 1955.

~~CONFIDENTIAL~~

UNCLASSIFIED

8. Mills, R. D. and Jackson, P. E., *Measurement of Erosion on the Floor of San Diego and La Jolla Bays*. Unpublished manuscript, Navy Electronics Laboratory, September 1953.
9. Navy Electronics Laboratory Report 457, *Detection of Buried Targets by Acoustical Means; a Feasibility Study*, by J. C. Hayes, CONFIDENTIAL, 14 June 1954.
10. Inman, D. I., *Behavior of Ground Mines in La Jolla Bay*. Personal communication, Scripps Institution of Oceanography, April 1957.
11. Munk, W. H. and Sargent, M. C., "Adjustment of Bikini Atoll to Ocean Waves," (Chapter C of Geological Survey Professional Paper 260-B, C, D; Part 2, *Oceanography*, p. 275-280, 1954.
12. Sverdrup, H. U. and others, *The Oceans, their Physics, Chemistry, and General Biology*, p. 90, Prentice-Hall, 1946.
13. Hjulstrom, F., "Transportation of Detritus by Moving Water," in *Recent Marine Sediments, a Symposium*, p. 5-31, American Association of Petroleum Geologists, 1939.
14. Navy Electronics Laboratory Report 785, *Some Major Environmental Factors Affecting the AN/UQS-1B Sonar Performance*, by A. J. Carsola and others, CONFIDENTIAL, 10 June 1957.
15. Fisher, R. L., *Sediment Transported along the Shelf of La Jolla Bay*. Personal communication, Scripps Institution of Oceanography, April 1957.

UNCLASSIFIED

Navy Electronics Laboratory
Report 861

THE BURIAL AND SCOURING OF GROUND MINES ON A SAND BOTTOM (U), by R. F. Dill. 32 p., 23 September 1958.
~~CONFIDENTIAL~~

Ground mines and other objects on the sea bottom were observed at water depths from 12 to 69 feet over a period of 1 year at the NEL Mission Beach Test Area. Scour depressions which developed were studied by SCUBA-equipped laboratory personnel.

Most of the scour occurred within the first 4 days after placement of the mines, and was caused by the increase in current velocity and turbulence resulting from interference with the normal oscillatory bottom currents. Soon after placement the rate of burial decreased rapidly, and scour depressions reached equilibrium with the existing bottom oscillatory currents. Very little change in the bottom micro-topography around the mines occurred thereafter except during periods of high swell induced by storms when the

(over)

AS 14101
NE 051456-846.12 (NEL L1-7)
NE 051456-19 (NEL E4-4)

~~This card is CONFIDENTIAL~~

1. Naval mines - Test results
I. Dill, R. F.

Navy Electronics Laboratory
Report 861

THE BURIAL AND SCOURING OF GROUND MINES ON A SAND BOTTOM (U), by R. F. Dill. 32 p., 23 September 1958.
~~CONFIDENTIAL~~

Ground mines and other objects on the sea bottom were observed at water depths from 12 to 69 feet over a period of 1 year at the NEL Mission Beach Test Area. Scour depressions which developed were studied by SCUBA-equipped laboratory personnel.

Most of the scour occurred within the first 4 days after placement of the mines, and was caused by the increase in current velocity and turbulence resulting from interference with the normal oscillatory bottom currents. Soon after placement the rate of burial decreased rapidly, and scour depressions reached equilibrium with the existing bottom oscillatory currents. Very little change in the bottom micro-topography around the mines occurred thereafter except during periods of high swell induced by storms when the

(over)

AS 14101
NE 051456-846.12 (NEL L1-7)
NE 051456-19 (NEL E4-4)

~~This card is CONFIDENTIAL~~

1. Naval mines - Test results
I. Dill, R. F.

Navy Electronics Laboratory
Report 861

THE BURIAL AND SCOURING OF GROUND MINES ON A SAND BOTTOM (U), by R. F. Dill. 32 p., 23 September 1958.
~~CONFIDENTIAL~~

Ground mines and other objects on the sea bottom were observed at water depths from 12 to 69 feet over a period of 1 year at the NEL Mission Beach Test Area. Scour depressions which developed were studied by SCUBA-equipped laboratory personnel.

Most of the scour occurred within the first 4 days after placement of the mines, and was caused by the increase in current velocity and turbulence resulting from interference with the normal oscillatory bottom currents. Soon after placement the rate of burial decreased rapidly, and scour depressions reached equilibrium with the existing bottom oscillatory currents. Very little change in the bottom micro-topography around the mines occurred thereafter except during periods of high swell induced by storms when the

(over)

1. Naval mines - Test results
I. Dill, R. F.

Navy Electronics Laboratory
Report 861

THE BURIAL AND SCOURING OF GROUND MINES ON A SAND BOTTOM (U), by R. F. Dill. 32 p., 23 September 1958.
~~CONFIDENTIAL~~

Ground mines and other objects on the sea bottom were observed at water depths from 12 to 69 feet over a period of 1 year at the NEL Mission Beach Test Area. Scour depressions which developed were studied by SCUBA-equipped laboratory personnel.

Most of the scour occurred within the first 4 days after placement of the mines, and was caused by the increase in current velocity and turbulence resulting from interference with the normal oscillatory bottom currents. Soon after placement the rate of burial decreased rapidly, and scour depressions reached equilibrium with the existing bottom oscillatory currents. Very little change in the bottom micro-topography around the mines occurred thereafter except during periods of high swell induced by storms when the

(over)

AS 14101
NE 051456-846.12 (NEL L1-7)
NE 051456-19 (NEL E4-4)

~~This card is CONFIDENTIAL~~

1. Naval mines - Test results
I. Dill, R. F.

UNCLASSIFIED
CONFIDENTIAL

INITIAL DISTRIBUTION LIST

(One copy to each addressee unless otherwise specified)

Chief, Bureau of Ships (Code 312) (12 copies)
(Code 538)
(B. King Couper (Code 530)
Chief, Bureau of Ordnance (Re6) (Ad3) (2)
(Lt. B. A. Hawkins)
Chief, Bureau of Aeronautics (TD-414)
Chief, Bureau of Medicine and Surgery
(Research Division)
Chief of Naval Personnel (Pers 15) (3)
(Cdr. G. M. Hogerman, Functional Training Section)
(Dr. J. T. Dailey)
Chief of Naval Operations (Op-37) (2)
(Op-315B, Cdr. G. C. Ellerton, Jr.)
(Op-343)
(Op-602, Capt. R. H. Boss)
(Op-315R) (Op-316)
Chief of Naval Research
(Code 411) (Code 416) (Code 418)
(Code 439) (Code 441) (Code 465)
(Code 466)
Commander in Chief, U. S. Pacific Fleet
Commander in Chief, U. S. Atlantic Fleet
Commander Operational Development Force, U. S.
Atlantic Fleet (1)
Commander Mine Force, U. S. Pacific Fleet (2)
Commander Western Sea Frontier
Commander Southern Sector, Western Sea Frontier
Commander Central Sector, Western Sea Frontier
Commander Northern Sector, Western Sea Frontier
Commander Hawaiian Sea Frontier
Commander U. S. Naval Forces, Far East (2)
Commander U. S. Naval Forces, Philippines
Commander U. S. Naval Forces Marianas
Commander Amphibious Force, U. S. Pacific Fleet (2)
Commander Service Force, U. S. Pacific Fleet
Commander, U. S. Naval Air Development Center
(Library)
Commander, U. S. Naval Air Missile Test Center
(Technical Library)
Commander, U. S. Naval Air Test Center (NANEP) (2)
Commander, U. S. Naval Ordnance Laboratory
(Library) (2)
Commander, U. S. Naval Ordnance Test Station
(Pasadena Annex Library)
Commanding Officer and Director, David Taylor
Model Basin (Library) (2)
Commanding Officer and Director, U. S. Navy
Underwater Sound Laboratory (Code 1450) (3)
(Russell I. Mason)
Director, U. S. Naval Engineering Experiment
Station (Library)
Director, U. S. Naval Research Laboratory (Code
2021) (2)
Director, U. S. Navy Underwater Sound Reference
Laboratory (Library)
Commanding Officer, U. S. Fleet Sonar School,
San Diego
Commanding Officer, U. S. Naval School, Underwater
Swimmers, U. S. Naval Station, Key West, Fla.
Commanding Officer, Underwater Demolition Unit
ONE
Commanding Officer, Underwater Demolition Unit
TWO
Commanding Officer, Explosive Ordnance Disposal
Technical Center, U. S. Naval Powder Factory,
Indian Head, Md.
Commanding Officer, Beach Jumper Unit Two, U. S.
Naval Amphibious Base, Little Creek, Va.
Commanding Officer, Mine Hunter Unit, U. S. Naval
Amphibious Base, Little Creek, Va.
Commanding Officer, U. S. Navy Mine Defense
Laboratory (Code 712) (J. M. Seawright)
Commanding Officer, Office of Naval Research,
Pasadena Branch
Commanding Officer, Mine Warfare Evaluation
Detachment
Commanding Officer, U. S. Naval Medical Research
Institute, National Naval Medical Center (Dr. S. N.
Stein) Bethesda, Md.
Commanding Officer, Naval Photographic Center,
U. S. Naval Air Station, Anacostia
Commanding Officer, U. S. Naval Submarine Base,
New London

Officer in Charge, Experimental Diving Unit (Lt. E. H.
Lamphier (MC) USNR) U. S. Naval Gun Factory
Officer in Charge, U. S. Naval Medical Research
Laboratory (Cdr. J. L. Kinsey)
(Cdr. Gerald J. Duffner (MC))
(Dr. K. E. Schaefer)
Officer in Charge, Experimental Diving Unit, U. S.
Naval Gun Factory
Commanding Officer, U. S. Naval Aero-Medical Re-
search Laboratory (Dr. M. Radnofsky) U. S. Naval
Shipyard, Philadelphia, Pa.
Hydrographer, U. S. Navy Hydrographic Office (1)
(Air Weather Service Liaison Office)
(Division of Oceanography)
Senior Navy Liaison Officer, U. S. Navy Electronics
Liaison Office
Superintendent, U. S. Naval Postgraduate School
(Library) (2)
Navy Representative, Project LINCOLN,
Massachusetts Institute of Technology
Commanding Officer, G2-Headquarters, Marine Corps,
Organization and Training (Capt. R. H. Porter,
USMC) Navy Annex
Assistant Secretary of Defense, Research and
Development (Technical Library Branch)
Assistant Chief of Staff, G-2, U. S. Army (Document
Library Branch) (3)
Chief of Engineers, U. S. Army (Engineer Research
and Development Div., Field Engineering Branch)
The Quartermaster General, U. S. Army (Research
and Development Division, CBR Liaison Officer)
Commanding General, Redstone Arsenal
(Technical Library)
Commanding Officer, Transportation Research and
Development Command (TRAD-TO-1)
Commanding General, Continental Army Command
(ATDEV)
Resident Member, Beach Erosion Board, Corps of
Engineers, U. S. Army
Commander, Air Defense Command
(Office of Operations Analysis)
Commander, Air University (Air University Library,
CR-5028)
Commander, Strategic Air Command
(Operations Analysis)
Commander, Air Force Armament Center (ACGL)
Commander, Air Force Cambridge Research Center
(CRQST-2)
Commandant, U. S. Coast Guard (Aerology and
Oceanography Section)
Commander, International Ice Patrol,
U. S. Coast Guard
University of California, Director, Marine Physical
Laboratory, San Diego, California
University of California, Director, Scripps Institution
of Oceanography (Library), La Jolla, California
(Adm. Charles Wheelock) (Robert F. Fisher)
(Frank Snodgrass) Conrad Limbaugh)
(Dr. Frances P. Shepard)

VIA BUREAU OF SHIPS:

Executive Secretary (George Wood), Committee on
Undersea Warfare, National Research Council
(J. S. Coleman)
Director, U. S. Coast and Geodetic Survey
Brown University, Director, Research Analysis Group
University of California at Los Angeles
(Dr. D. B. Lindsley)
University of California, Radiation Laboratory
(Dr. Hugh Bradner) (2)
Colorado College, Department of Physics
(Prof. Charles H. Townes)
Columbia University, Director, Hudson Laboratories,
Dobbs Ferry, New York (Roberto Frassetto)
Harvard University, Director, Acoustics Research
Laboratory (Dr. F. V. Hunt)
(Dr. Harvey Brooks, Cruft Laboratory)
The Johns Hopkins University, Director, Chesapeake
Bay Institute (Library), Annapolis, Maryland
(Dr. Donald W. Pritchard)

Massachusetts Institute of Technology
(J. C. R. Licklider)
(Dr. Harold E. Edgerton)
University of Miami, Director, Marine Laboratory
University of Michigan, Director, Engineering Research
Institute (Dr. J. C. Johnson)
Pennsylvania State University, Director,
Ordnance Research Laboratory
University of Southern California, Director, Allan
Hancock Foundation, Los Angeles, Calif.
Agricultural and Mechanical College of Texas, Head
Department of Oceanography (Dr. D. F. Leipper)
The University of Texas
Director, Defense Research Laboratory
University of Washington, Department of Oceanog-
raphy (Dr. R. H. Fleming, Executive Officer)
Director, Lamont Geological Observatory (M. Ewing)
The Director, Woods Hole Oceanographic Institution
(David Owen)
Bell Telephone Laboratories, Incorporated
(Charles F. Wiebusch)
Vitro Corporation of America, Silver Spring
Laboratory (Library)
Director, The Oceanographic Institute, Florida State
University, Tallahassee, Fla.
Director, Narragansett Marine Laboratory,
Kingston, R. I.
Head, Dept. of Oceanography, Texas A&M College,
College Station, Texas
Director, Hawaii Marine Laboratories, University of
Hawaii, Honolulu, T. H.
Director of Marine Science, Port Aransas, Texas
Oregon State College, School of Science (Dr. Wa-
V. Burt, Associate Prof. of Oceanography)
Corvallis, Oregon
Texas A and M College, Marine Laboratory of
Dept of Oceanography (R. MacAllister) 12th
and Strand, Galveston, Texas
University of Chicago (Dr. W. D. Neff, Dept of
Psychology) Chicago, Ill.
Pacific Oceanic Fisheries Investigations, Honolulu
T. H. (Thomas S. Austin)
Hawaii Board of Agriculture and Forestry (Vernon
Brack, Division of Fish and Game) P. O. Box 5-
Honolulu 1, T. H.
Monterey Oil Co. (Thomas A. Baldwin) 430 Star
Office Bldg., 900 Wilshire Blvd., Los Angeles
Calif.
University of Pennsylvania (Prof. G. P. Hornow)
(Dr. C. J. Lambertsen, Laboratory of Pharmacology,
School of Medicine) Philadelphia 4, Pa.
Rice Institute (Dr. W. V. Houston) Houston, Texas
Pennsylvania State University (Dr. E. A. Walk
State College, Pa.
Raytheon Corporation (Dr. Ivan Getting) Waltham,
Massachusetts
Panel on Underwater Swimmers, N.R.C. (Loyal
Goff) 2101 Constitution Ave, Washington, D. C.
Aerajet General Corporation, Underwater Engineer
Division (Calvin A. Gangwer) Azusa, Calif. (3)
Fairchild Engine and Airplane Corporation (A.
Gregory, Engine Division) Farmingdale, Long
Island, New York
General Electric Co. (Walter A. Hahn, Jr.) Rude
Bldg., Syracuse, New York
Mr. J. R. R. Harter, 4953 Brandywine St., N.J.
Washington 16, D. C.
Medical College of Virginia (Dr. E. C. Hoff)
Richmond, Va.
Advisory Committee on Civil Defense National A-
cademy of Sciences-National Research Council
(Willard N. Boscom, Technical Director) 1346
Connecticut Ave., N.W., Washington, D. C.
Engineer Research and Development Laboratory
(J. Thomas Blair) Fort Belvoir, Va.
Director, Garfield Thomas Water Tunnel, Ordnance
Research Laboratory, P. O. Box 30, State Coll.
Pa.
U. S. Liaison Committee for Oceanic Research,
(James Dugan) 245 East 21st Street, New York,
N. Y. (5)

UNCLASSIFIED
CONFIDENTIAL