

AD-A063 011

ROME AIR DEVELOPMENT CENTER GRIFFISS AFB N Y
ELECTRICAL EQUIPMENT SHELTERS S-514A/G ABD S-515A/G, (U)
NOV 78 J J GUBA, M B RUDENSEY
RADC-TR-78-242

F/G 13/13

UNCLASSIFIED

[OF 1

AD
A063011



NI



END
DATE
FILMED
3-79
DDC

LEVEL II

(12)
52



RADC-TR-78-242
In-House Report
November 1978

**ELECTRICAL EQUIPMENT SHELTERS
S-514A/G AND S-515A/G**

John J. Guba
Mark B. Rudensey

APPROVED FOR PUBLIC RELEASE; DISTRIBUTION UNLIMITED

DDC
RECEIVED
9 JAN 1979
E

ROME AIR DEVELOPMENT CENTER
Air Force Systems Command
Griffiss Air Force Base, New York 13441

79 01 08 034

DDC FILE COPY
ADA063011

This report has been reviewed by the AIOC Information Office (IOI) and the Committee for the Review of Security Information Service (CRSIS). AIOC CRSIS will be available to the general public, including foreign nationals.

SECRET-20-202 has been reviewed and is approved for publication.

APPROVED: *Charles F. Booth*

CHARLES F. BOOTH
Chief, Intelligence Branch

APPROVED: *Joseph J. Nardone*

JOSEPH J. NARDONE
Chief, Security & Responsibility Division

FOR THE COMMISSIONER: *John P. Hines*

JOHN P. HINES
Acting Chief, P. Hines Office

This report contains information that is classified as secret under the AIOC regulations. It is the responsibility of the recipient to ensure that this information is not disclosed to unauthorized persons. This will assist in maintaining a secure intelligence base.

Do not destroy this copy. Retain for security.

MISSION
of
Rome Air Development Center

RADC plans and conducts research, exploratory and advanced development programs in command, control, and communications (C³) activities, and in the C³ areas of information sciences and intelligence. The principal technical mission areas are communications, electromagnetic guidance and control, surveillance of ground and aerospace objects, intelligence data collection and handling, information system technology, ionospheric propagation, solid state sciences, microwave physics and electronic reliability, maintainability and compatibility.



UNCLASSIFIED

SECURITY CLASSIFICATION OF THIS PAGE (When Data Entered)

REPORT DOCUMENTATION PAGE		READ INSTRUCTIONS BEFORE COMPLETING FORM
14 1. REPORT NUMBER RADC-TR-78-242	2. GOVT ACCESSION NO.	3. RECIPIENT'S CATALOG NUMBER
6 4. TITLE (and Subtitle) ELECTRICAL EQUIPMENT SHELTERS S-514A/G and S-515A/G	5. TYPE OF REPORT & PERIOD COVERED In-House	
	6. PERFORMING ORG. REPORT NUMBER N/A	
10 7. AUTHOR(s) John J. Guba Mark B. Rudensey	8. CONTRACT OR GRANT NUMBER(s) F30602-77-C-0117 ^{ew}	
	9. PERFORMING ORGANIZATION NAME AND ADDRESS Rome Air Development Center (RBES) Griffiss AFB NY 13441	
11 11. CONTROLLING OFFICE NAME AND ADDRESS Rome Air Development Center (IRAE) Griffiss AFB NY 13441	10. PROGRAM ELEMENT, PROJECT, TASK AREA & WORK UNIT NUMBERS 310116 68310033	
	12. REPORT DATE November 1978	
14. MONITORING AGENCY NAME & ADDRESS (if different from Controlling Office) Same <i>1238p.</i>	13. NUMBER OF PAGES 39	
	15. SECURITY CLASS. (of this report) UNCLASSIFIED	
15a. DECLASSIFICATION/DOWNGRADING SCHEDULE N/A		
16. DISTRIBUTION STATEMENT (of this Report) Approved for public release; distribution unlimited.		
17. DISTRIBUTION STATEMENT (of the abstract entered in Block 20, if different from Report) Same		
18. SUPPLEMENTARY NOTES N/A		
19. KEY WORDS (Continue on reverse side if necessary and identify by block number) Shelters Ground Electronic Equipment Maintenance		
20. ABSTRACT (Continue on reverse side if necessary and identify by block number) This report presents a general description and the results of an effort initiated by RADC to produce a highly mobile and air transportable electronics maintenance shelter complex that can be used to house equipment necessary to provide maintenance facilities for US Air Force electronic systems.		

DD FORM 1473 1 JAN 73

EDITION OF 1 NOV 65 IS OBSOLETE

UNCLASSIFIED

SECURITY CLASSIFICATION OF THIS PAGE (When Data Entered)

309 050

LB

UNCLASSIFIED

SECURITY CLASSIFICATION OF THIS PAGE(When Data Entered)

1. REPORT NUMBER	2. SECURITY CLASSIFICATION	3. DATE
4. TITLE	5. AUTHOR	6. PERIODICITY
7. ABSTRACT	8. SUBJECT TERMS	9. DISTRIBUTION STATEMENT
10. DISTRIBUTION STATEMENT	11. DISTRIBUTION STATEMENT	12. DISTRIBUTION STATEMENT
13. DISTRIBUTION STATEMENT	14. DISTRIBUTION STATEMENT	15. DISTRIBUTION STATEMENT
16. DISTRIBUTION STATEMENT	17. DISTRIBUTION STATEMENT	18. DISTRIBUTION STATEMENT
19. DISTRIBUTION STATEMENT	20. DISTRIBUTION STATEMENT	21. DISTRIBUTION STATEMENT
22. DISTRIBUTION STATEMENT	23. DISTRIBUTION STATEMENT	24. DISTRIBUTION STATEMENT
25. DISTRIBUTION STATEMENT	26. DISTRIBUTION STATEMENT	27. DISTRIBUTION STATEMENT
28. DISTRIBUTION STATEMENT	29. DISTRIBUTION STATEMENT	30. DISTRIBUTION STATEMENT
31. DISTRIBUTION STATEMENT	32. DISTRIBUTION STATEMENT	33. DISTRIBUTION STATEMENT
34. DISTRIBUTION STATEMENT	35. DISTRIBUTION STATEMENT	36. DISTRIBUTION STATEMENT
37. DISTRIBUTION STATEMENT	38. DISTRIBUTION STATEMENT	39. DISTRIBUTION STATEMENT
40. DISTRIBUTION STATEMENT	41. DISTRIBUTION STATEMENT	42. DISTRIBUTION STATEMENT
43. DISTRIBUTION STATEMENT	44. DISTRIBUTION STATEMENT	45. DISTRIBUTION STATEMENT
46. DISTRIBUTION STATEMENT	47. DISTRIBUTION STATEMENT	48. DISTRIBUTION STATEMENT
49. DISTRIBUTION STATEMENT	50. DISTRIBUTION STATEMENT	51. DISTRIBUTION STATEMENT
52. DISTRIBUTION STATEMENT	53. DISTRIBUTION STATEMENT	54. DISTRIBUTION STATEMENT
55. DISTRIBUTION STATEMENT	56. DISTRIBUTION STATEMENT	57. DISTRIBUTION STATEMENT
58. DISTRIBUTION STATEMENT	59. DISTRIBUTION STATEMENT	60. DISTRIBUTION STATEMENT
61. DISTRIBUTION STATEMENT	62. DISTRIBUTION STATEMENT	63. DISTRIBUTION STATEMENT
64. DISTRIBUTION STATEMENT	65. DISTRIBUTION STATEMENT	66. DISTRIBUTION STATEMENT
67. DISTRIBUTION STATEMENT	68. DISTRIBUTION STATEMENT	69. DISTRIBUTION STATEMENT
70. DISTRIBUTION STATEMENT	71. DISTRIBUTION STATEMENT	72. DISTRIBUTION STATEMENT
73. DISTRIBUTION STATEMENT	74. DISTRIBUTION STATEMENT	75. DISTRIBUTION STATEMENT
76. DISTRIBUTION STATEMENT	77. DISTRIBUTION STATEMENT	78. DISTRIBUTION STATEMENT
79. DISTRIBUTION STATEMENT	80. DISTRIBUTION STATEMENT	81. DISTRIBUTION STATEMENT
82. DISTRIBUTION STATEMENT	83. DISTRIBUTION STATEMENT	84. DISTRIBUTION STATEMENT
85. DISTRIBUTION STATEMENT	86. DISTRIBUTION STATEMENT	87. DISTRIBUTION STATEMENT
88. DISTRIBUTION STATEMENT	89. DISTRIBUTION STATEMENT	90. DISTRIBUTION STATEMENT
91. DISTRIBUTION STATEMENT	92. DISTRIBUTION STATEMENT	93. DISTRIBUTION STATEMENT
94. DISTRIBUTION STATEMENT	95. DISTRIBUTION STATEMENT	96. DISTRIBUTION STATEMENT
97. DISTRIBUTION STATEMENT	98. DISTRIBUTION STATEMENT	99. DISTRIBUTION STATEMENT
100. DISTRIBUTION STATEMENT	101. DISTRIBUTION STATEMENT	102. DISTRIBUTION STATEMENT

UNCLASSIFIED

SECURITY CLASSIFICATION OF THIS PAGE(When Data Entered)

Blank

ACKNOWLEDGEMENT

Acknowledgement is made to TSgt B. Decker, USAFSS/LGMS, and Mr. W. Ciccarelli, General Manager of Gichner Mobile Systems. Their efforts made it possible to complete the design, fabrication, testing and delivery of a production quantity of 9 sets of Shelters in a period of 12 months from the date of award of the contract. Their cooperation and assistance led to the successful accomplishment of this project.

ACCESSION for	
NTIS	White Section <input checked="" type="checkbox"/>
DDC	Buff Section <input type="checkbox"/>
UNANNOUNCED	<input type="checkbox"/>
JUSTIFICATION	
BY	
DISTRIBUTION/AVAILABILITY CODES	
Dist.	SPECIAL
A	

79 ⁱⁱⁱ 0.1-08 034

TABLE OF CONTENTS

	<u>Title</u>	<u>Page</u>
I	Introduction	1
II	Purpose of the Equipment	1
III	Mechanical Characteristics	2
IV	Electrical Characteristics	13
V	Modular Test Box	16
VI	Leading Particulars	20
	A. Physical Data	20
	Interior/Exterior	20
	B. Electrical	21
	C. DC Power Supply	21
	D. Shielding (Expanded)	21
	Frequency(MHz)/Shielding Effectiveness(dB)	21
	E. Frequency Converter	22
	F. Air Compressor	22
	G. U Factor	22
VII	General Miscellaneous Characteristics	22
	A. Mobilizer	22
	B. Altitude Pressure Equilization	24
	C. Humidity Indicators	24
	D. Shelter Repair Kit	24
	E. Shelter Complex Setup	24
	F. Other System Applications	26

LIST OF ILLUSTRATIONS

<u>Figure No.</u>	<u>Title</u>	<u>Page</u>
1	S-514A/G & S-515A/G Electrical Equipment Shelters	3
2	S-514A/G & S-515A/G Electrical Equipment Shelters in Complex Deployment	4
3	Repair Shelter Interior	5
4	Supply Shelter Interior	6
5	Shelter Complex Interior - Expanded Configuration (View A)	7
6	Shelter Complex Interior - Expanded Configuration (View B)	8
7	Power Distribution Panel	14
8	Modular Test Box	17
9	Maintenance Test Panel	19
10	Mounting of the Dolly Set	23
11	Jack Leveling Sequence (Sequences 1-3)	25
12	Shelter Complex Deployment (Steps 1&2)	27
13	Shelter Complex Deployment (Steps 3&4)	28
14	Shelter Complex Deployment (Steps 5&6)	29
15	Shelter Complex Deployment (Step 7)	30
16	Shelter Complex Tiedown	31

I INTRODUCTION

The need for highly mobile, air-transportable maintenance facilities has been a major problem facing the military ever since a high degree of systems mobility became essential. A facility designed and developed under RADC contract to meet this requirement is the S-514A/G and S-515A/G expandable shelter system.

Since most military equipment must be capable of operating in all areas of the world, the development of lightweight equipment imposes considerably more stringent requirements on the item than is normal for its commercial equivalent. The strength-to-weight ratio of the maintenance facility is significant in itself. Considering the natural and induced environments under which the equipment must operate, and the requirements imposed, the development of this item becomes a significant outstanding accomplishment.

II PURPOSE OF THE EQUIPMENT

The facilities described in this report are land, sea and air-transportable electronic equipment maintenance support shelters. They will give the using command the capability of testing and repairing operational electronic equipment in the field. The facilities were developed and manufactured by Gichner Mobile Systems, Inc. under RADC Contract F30602-77-C-0017.

Throughout this report, the Electrical Equipment Shelters will be referred to as the Shelter Complex or the Facility when assembled together and as the Repair Shelter (S-514A/G) and Supply Shelter (S-515A/G) when discussed separately.

The Electrical Equipment Shelters are S-514/G and S-515/G

expandable shelters which have been modified to permit use as a transportable ground electronics repair shop or a combination repair and supply facility when the individual shelters are expanded and operated together as a Shelter Complex (S-514A/G and S-515A/G). The approximate assembly (or disassembly) time for the complex is three hours using four persons to do the work. The shelters are used to house test equipment, spare parts and service equipment for testing, calibrating and repairing electronic communications and special purpose equipment. The S-514A/G Expandable Shelter is configured as a Repair Shelter and the S-515A/G Expandable Shelter is configured as a Supply Shelter. The internal configuration of the S-514A/G and S-515A/G which form the Repair Shelter and Supply Shelter include the installation of an AC/DC power distribution system, general and work area lighting, special workbenches, a terminal for the AIC-25 Intercommunication Set, test panels, test equipment racks, and part storage facilities. The shelters provide protection for maintenance personnel from adverse environmental conditions and also provide adequate working space and a comfortable working environment. The shelters are easily transportable and are capable of withstanding all hazards of shipment by road, rail, aircraft, or by International Standards Organization (ISO) ship or large landing craft. Figures 1-6 illustrate different aspects of the Shelter Complex and the individual shelters.

III MECHANICAL CHARACTERISTICS

Both of the Expandable Shelters, the S-514A/G Repair

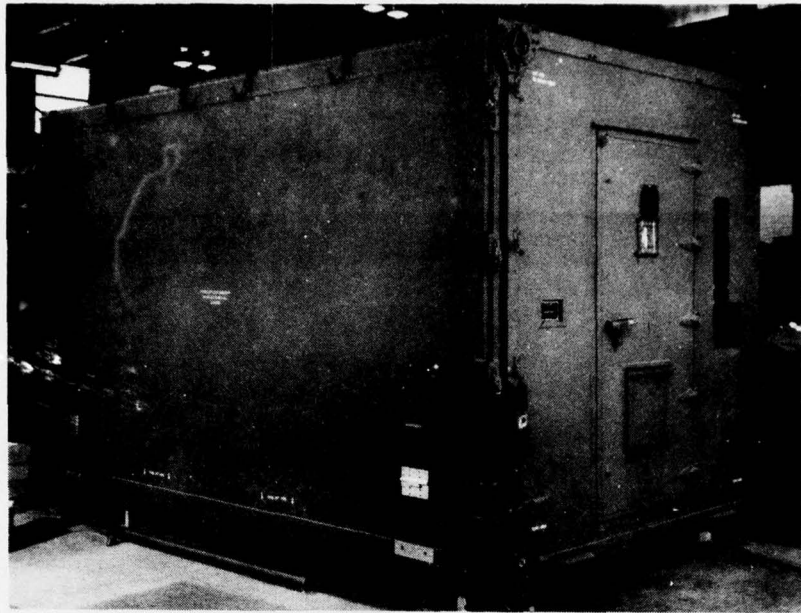

SUPPLY SHELTER S-515A/G

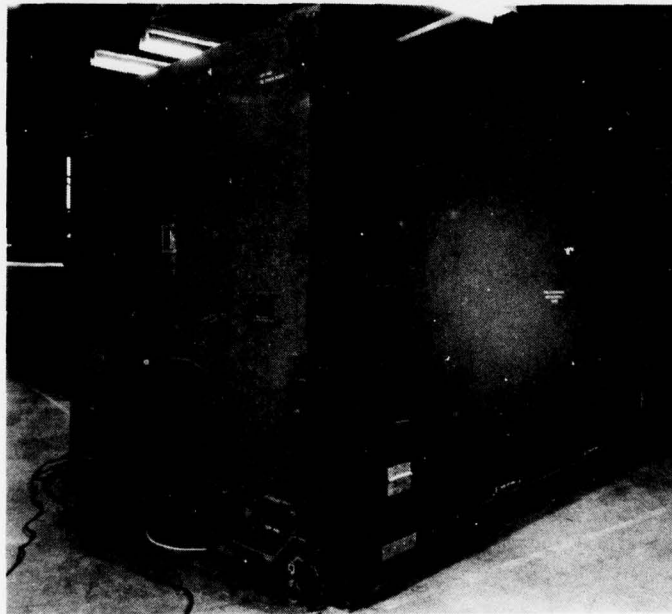

REPAIR SHELTER S-514A/G

FIGURE 1 - S-514A/G and S-515A/G ELECTRICAL EQUIPMENT SHELTERS

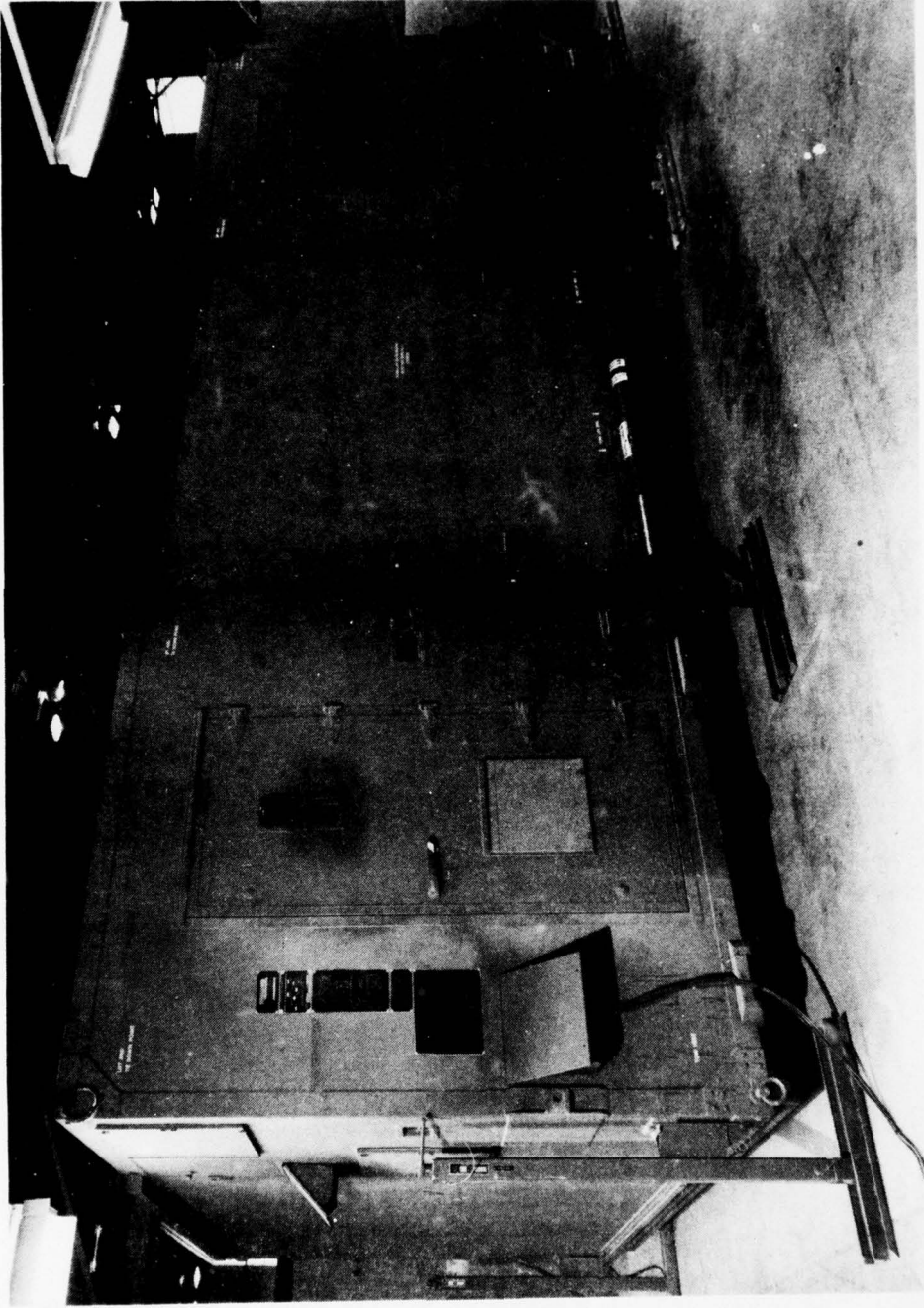

FIGURE 2 - S-514A/G and S-515A/G ELECTRICAL EQUIPMENT SHELTERS IN COMPLEX DEPLOYMENT



FIGURE 3 - REPAIR SHELTER INTERIOR

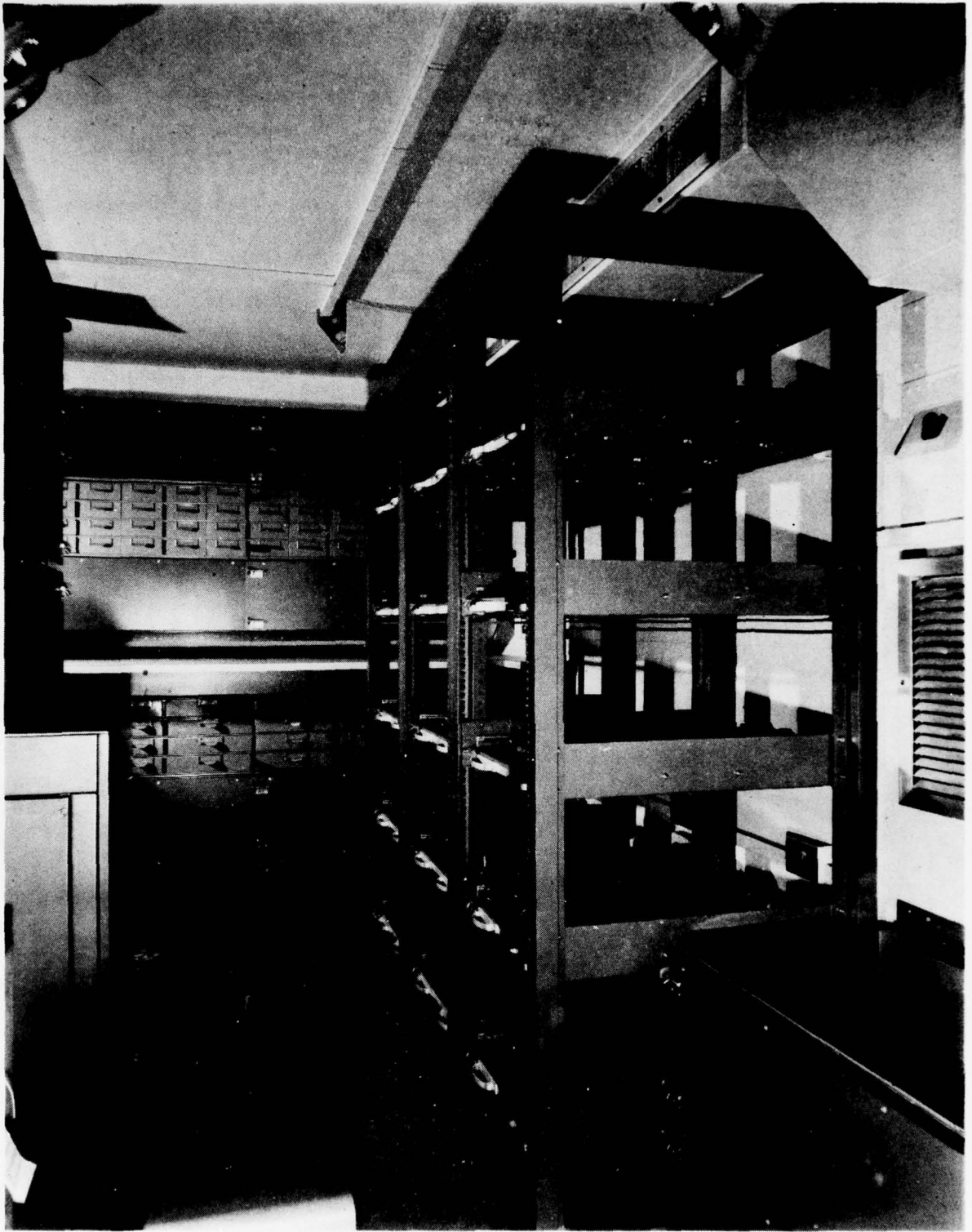

FIGURE 4 - SUPPLY SHELTER INTERIOR



FIGURE 5 - SHELTER COMPLEX INTERIOR - EXPANDED CONFIGURATION (VIEW A)

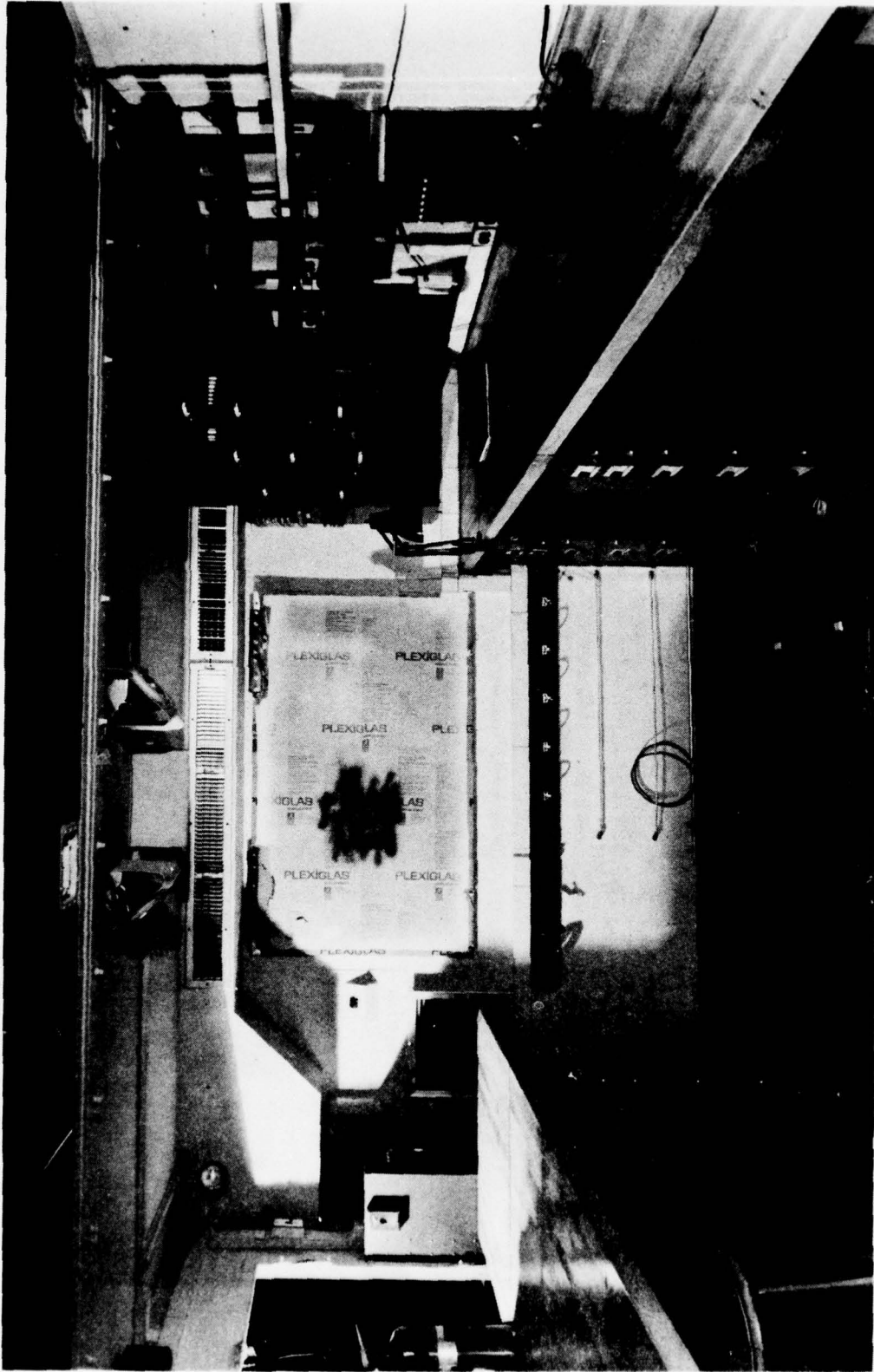

FIGURE 6 - SHELTER COMPLEX INTERIOR - EXPANDED CONFIGURATION (VIEW B)

Shelter and the S-515A/G Supply Shelter, are rectangular in shape and are constructed of aluminum skins forming a sandwich with a urethane core. The skins are welded and riveted to internal framing members. One end of each shelter has a personnel door that is provided with a louver, internal humidity indicator, and an anti-back draft (pressure relief) valve. One side of each shelter is provided with EMI/RFI filtered openings that are inlet and exhaust interfaces for air conditioning ducts. Air conditioners are not provided with the Repair Shelter or Supply Shelter, however, all provisions, including necessary cabling and connectors to interface with the standard Type A/E 32-C-24 and A/E 32-C-25 air conditioners, are provided with the shelters. Also included are the mounting provisions for the air conditioning remote control units. Air conditioning duct work is permanently mounted inside each shelter.

One side of each shelter consists of an adjustable side panel which is used as a roof or floor panel when the individual shelters are connected together as a Shelter Complex. A removable end panel is mounted externally on the opposite side wall panel during transport. This panel is used as one of the end panels when the shelters are combined to form the Shelter Complex. The four end corners of both the Repair Shelter and the Supply Shelter are provided with leveling jack mountings that allow leveling jacks to be used to level the shelters if they are deployed on a 0 to 10 percent incline. Selection and installation of the electronic test equipment to be used in the Shelter Complex is

made by US Air Force personnel as necessary. After the selection and installation of the various pieces of electronic test equipment, the individual shelters, or Shelter Complex, can operate as a repair and supply facility in a manner determined by policy and/or the local situation.

The Supply Shelter (S-515A/G) contains four matching dual-purpose rack bays constructed of aluminum channels that house adjustable shelves. These bays can accommodate paneled test equipment. The racks are shock and vibration mounted to protect the test equipment during transit. The shelves in the rack structures have a padded top and straps for securing equipment. The shelves are adjustable up and down and can slide in and out. Two 18-drawer metal cabinets (bolted together) provide storage for small parts. The drawers on the metal cabinets can be sealed to indicate if entry has been made. Each drawer is equipped with replaceable labels to identify the contents. A small shelf for the use of small accessory gear, such as a Microfiche Reader, has been provided in the Supply Shelter. Fifteen sets of multidrawer metal cabinets, assembled together, form a small parts storage area and work surface in the Supply Shelter. The drawers can be sealed, and each drawer is equipped with replaceable labels to identify the contents. A two-drawer security file, with a three-digit combination lock, is also located in the Supply Shelter.

A special rack designed for housing up to 250 pounds of test gear and special equipment is mounted horizontally above a workbench in the front of the Repair Shelter. This test equipment

rack is both shock and vibration mounted for equipment protection. The Repair Shelter also contains a maintenance test panel, cable and communication panels for routing cables and signals into and out of the Shelter Complex as necessary during maintenance operations. An equipment status board, a safety box, and several heavy duty wrecking tools are included in the Repair Shelter. The power distribution panel that controls the application of power to all areas of the Shelter Complex is also located in the Repair Shelter.

Two 36 inch by 93 inch removable bolt-down type workbenches with an electrical convenience outlet strip on top are included with the Shelter Complex. When the two shelters are arranged in the expanded Shelter Complex configuration, a removable workbench is located on the end walls in the expanded area of the assembled Shelter Complex. Two 12 inch by 60 inch removable bolt-down type shelves that can be used to support TO's, books, or lightweight equipment are located above the bolt-down workbenches at the ends of the expanded Shelter Complex.

A hinged plexiglass equipment status board to cover poster-board charts is supplied in the Repair Shelter. An eight day wind-up clock is also provided in the Repair Shelter. A hinged workbench (due to the door opening of the shelter) is supplied with a reversible warning sign for attachment to the door of the Repair Shelter that indicates "no exit" when the shelters are deployed as a Shelter Complex. The reverse of the sign indicates that the fold down workbench is not to be used when the shelter is deployed singly. There is also a permanently installed

36 inch by 76 inch workbench in the Repair Shelter.

A safety board is included in the Repair Shelter and consists of the following items:

1. Safety Operating Instructions
2. Resuscitator
3. First Aid and Snake Bite Kit
4. Fire Extinguisher (10 lb, dry chemical) - One in each Shelter (Class BC)
5. Medical Service Walking Cane
6. Flashlight
7. 15 Foot Rope
8. Electrically Insulated Gloves
9. Wrecker Bar
10. Fire Axe
11. Ground Rod
12. Ten Pound Sledge Hammer
13. Grounding Stick (Shorting Stick).

A lightweight, oilless, noncontaminating air compressor is included in the Repair Shelter. It supplies sufficient regulated pressure to clean equipment, circuit boards and external items (by feeding a hose through the wall to the outside of the shelter). It supplies 60 PSIG at 1.2 SCFM.

A special combination shock and vibration mounted test equipment pallet, 30 inches by 45 inches, used to strap down test equipment during transit is also provided in the Repair Shelter.

Floor rings are provided on the floor of the shelters for strapping down equipment during transportation of the shelters. The Shelter Complex also contains special roof mountings for three detachable antennæ (two whip antennas and one discone).

IV ELECTRICAL CHARACTERISTICS

The electrical system for the Shelter Complex is controlled from a power distribution panel located in the Repair Shelter. The Shelter Complex operates on three-phase input power at 120/208 volts, connected in a wye configuration. Input power can be supplied at either 60Hz or 400Hz, however, the input power at the two different frequencies must be applied to different connectors on the power input panel. The power input panel contains the two input power receptacles and a ground stud. Input power consumption for either 60Hz or 400Hz operation is limited to 50 amperes per phase.

The power distribution panel is located on the inside rear wall (door end) of the Repair Shelter (See Figure 7). The power distribution panel contains input line filters for RFI filtering and circuit breakers for protecting the various circuits and equipments from overload conditions. Indicator lights on the panel indicate which power input power circuit (60Hz or 400Hz) is being used and if all three phases of the input power are available. A switchable voltmeter and ammeter allow each phase of the input power to be monitored individually. Separate meters are provided for the 60Hz circuits and the 400Hz circuits. A variable 50 ampere DC power supply, operating on either 60Hz

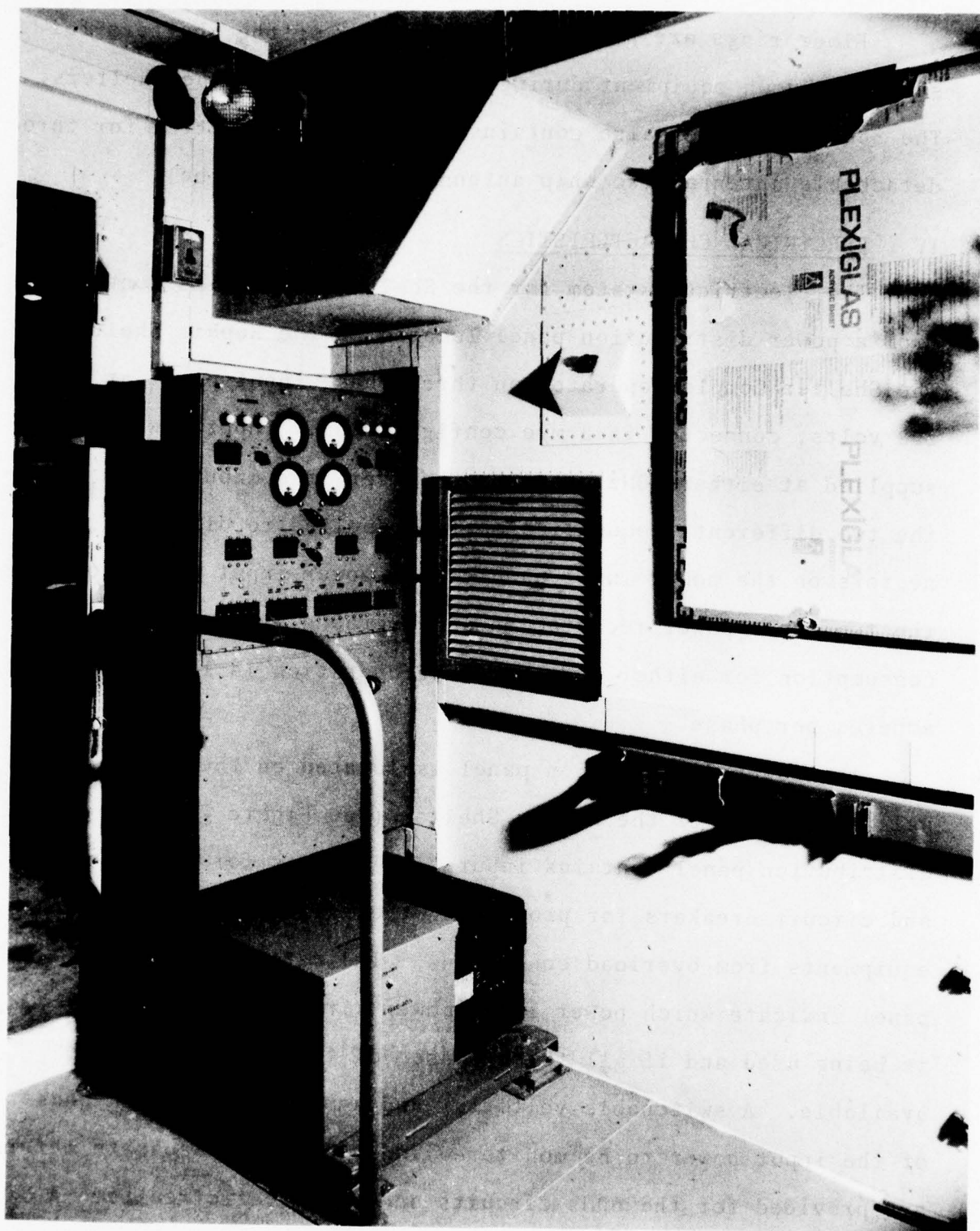

FIGURE 7 - POWER DISTRIBUTION PANEL

or 400Hz input power, adjustable from 20 to 40 volts DC, provides a nominal 28VDC. A 400Hz, three-phase input frequency converter delivers 2KVA of single phase 60Hz power. Thus, some 60Hz power is available for use at all times.

A framed RFI tight cable entrance panel, with an outside cover, houses four antenna feedthrough connectors, one RF filtered telephone connector (standard four wire), six hybrid connectors (four coaxial pin module and 23 standard pin module), and one bulkhead connector for the C-65671 AIC-25 control box. Specific use of these items is determined by local procedures and the tactical situation.

Provisions for utilizing air conditioners are included with each shelter. When the air conditioners are to be used, the control box is removed from the air conditioner and mounted on the wall of the shelter. Cables are then connected between the control unit, and the air conditioner is operated remotely from the shelter.

Throughout the Shelter Complex there are incandescent lights and high intensity lights to provide both general lighting and selective lighting for small parts. The Repair Shelter is supplied with five incandescent lights and the Supply Shelter with six. The high intensity lights (for selective lighting) are relocatable, but are generally used above the workbenches.

Throughout the Shelter Complex there are a series of 60Hz and 400Hz duplex receptacles to provide adequate power to satisfy the power requirements of the equipment used in the complex. Each

workbench has a set of power strips to operate from the 60Hz power source or from the 60Hz power provided by the frequency converter. The 60Hz receptacle boxes are color coded yellow and the 400Hz receptacle boxes are color coded red to prevent equipment damage due to using an incorrect power source.

A ground system is employed throughout the Shelter Complex which connects to the main ground in the power distribution panel. The workbenches in the Shelter Complex are equipped with a copper ground bus, which ties to the main ground, and the equipment racks have stainless steel bonding straps for electrical protection. Additionally, an external six-foot ground rod with a braided attaching wire is provided which connects to the ground stud.

V MODULAR TEST BOX

In many of the present fielded facilities used to conduct maintenance on diversified electronic equipment, the major problem that appears to be encountered by technicians is not only the lack of a device to provide the correct type of power, but also an interface to the power connectors. Electronics are supplied with various power connectors, such as AN, Bendix, Amphenol, and numerous others. In an attempt to reduce this problem to a minimum, a modular test box was developed for the Shelter Complex (Figure 8). There are two aluminum modular test boxes supplied with the Shelter Complex that are used to house plug-in modules for testing various electronic equipment. The test boxes have individual line switches and power-on indicators. The test boxes are wired for 400Hz, 3Ø power; 60Hz, 3Ø power, and 28 VDC. A total of 12 modules and

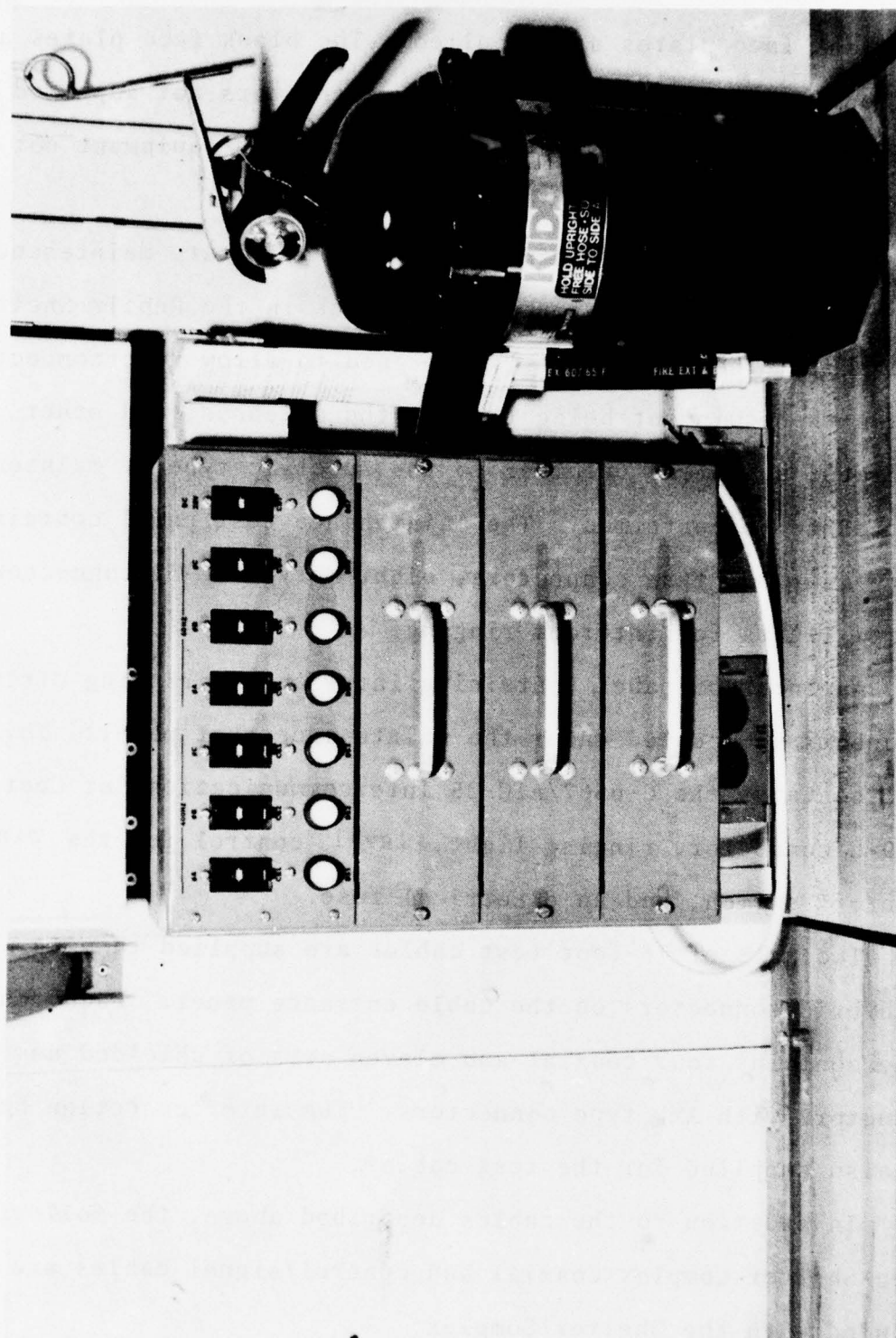

FIGURE 8 - MODULAR TEST BOX

four blank face plates are supplied. The blank face plates are provided for field fabrication using connectors not supplied with the Shelter Complex, but encountered with some equipment not identifiable at this time.

A maintenance test panel, used to facilitate maintenance, is mounted next to the overhead test rack in the Repair Shelter (Figure 9). The test panel is designed to allow interconnection between the equipment being tested, the antennas, and other associated equipment peculiar to the specific type of maintenance expected to be performed. The maintenance test panel contains twenty-four BNC type connectors, eight N type UG-30 connectors, and six lights for intercom ringing.

An intercom panel, containing intercom and ringing circuit components, is located under the maintenance test panel. This panel contains the C-6567/AIC-25 Intercommunication Set Control, a U79-G connector, ringing light, level control for the ring, an on/off switch, and an electrical fuse.

Two sets of 75-foot test cables are supplied to mate with the hybrid connectors on the cable entrance panel. Each test cable contains four coaxial and eleven sets of shielded dual conductors with AMP type connectors. Two interconnection boxes are also supplied for the test cables.

In addition to the cables described above, the following intra-Shelter Complex coaxial and control/signal cables are included with the Shelter Complex:

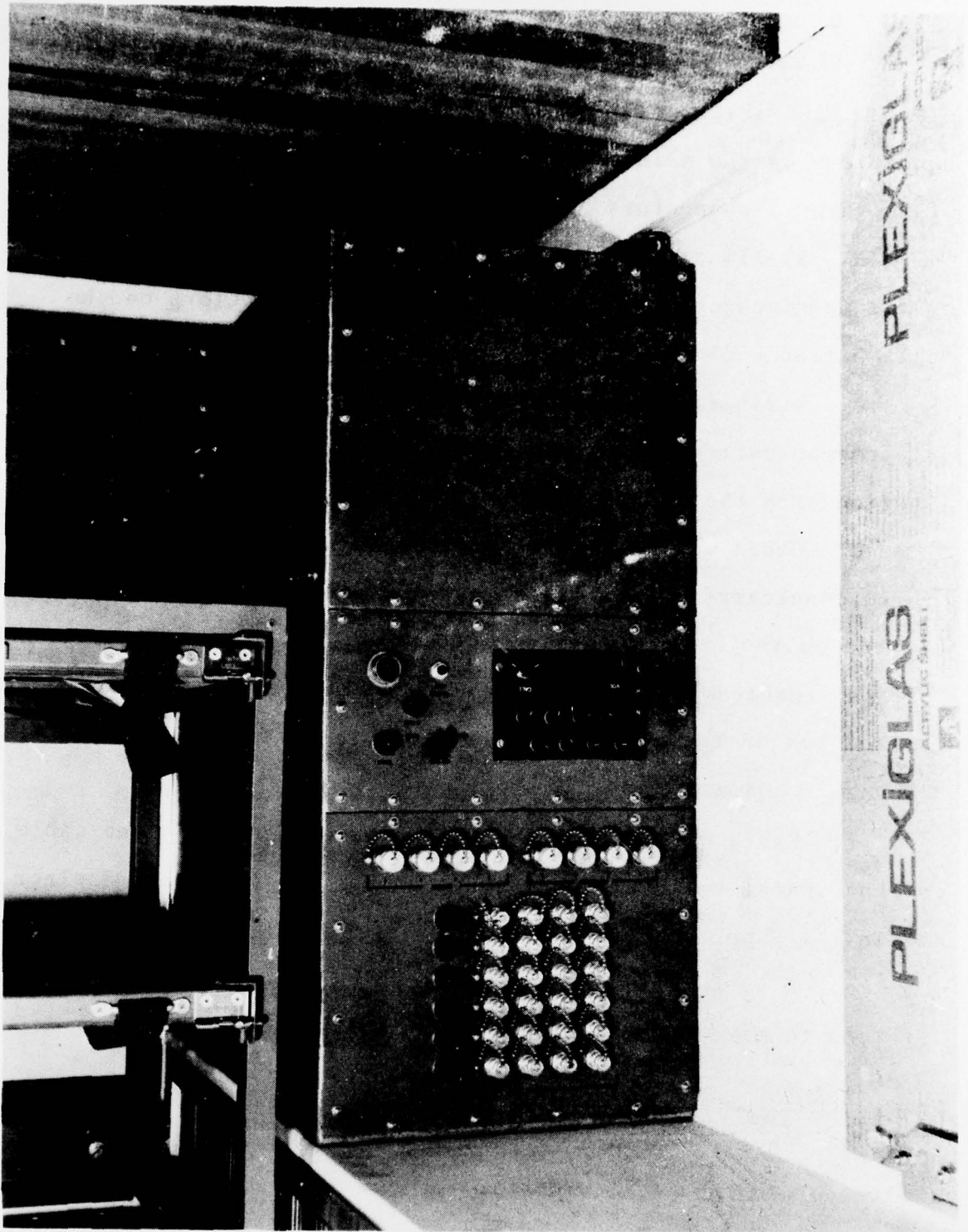

FIGURE 9 - MAINTENANCE TEST PANEL

a. RG-58 coaxial cables which are routed from the 24 BNC connectors on the maintenance test panel to the coaxial portions of the hybrid connectors on the cable entrance panel.

b. RB-214 coaxial cables from the eight type N connectors on the maintenance test panel to the type N connectors on the cable entrance panel.

c. Wiring to enable the C-6567/AIC-25 control box to furnish intercommunication with up to seven other facilities used in conjunction with the Repair Shelter.

d. Cable wiring (not used with the intercom) from the hybrid connectors on the cable entrance panel to terminal strips mounted on the back of the test equipment rack.

e. Cable wiring from the bulkhead connectors for the AIC-25 control box on the cable entrance panel to a terminal strip in the test equipment rack.

f. Cable wiring from the telephone connector on the cable entrance panel to a telephone junction box in the Repair Shelter and in the Supply Shelter.

g. A 50-foot interconnecting cable to connect the AIC-25 intercom to mate with a COMPASS EARS Central.

VI LEADING PARTICULARS

A. Physical Data:

Shelter Dimensions (individual)

Interior:

Length: 138 inches

Exterior:

Length: 146 inches (roof)

147 inches (floor)

Width: 80 inches

Width: 87 7/8 inches (below 16 inch
fording line)

88 inches (above 16 inch
fording line)

Height: 82 inches

Height: 93 inches

Expanded Length: 246 1/2 in. Expanded Length: 250 3/4 in.

Weights: S514A/G - 4,660 lbs

S515A/G - 4,900 lbs

B. Electrical:

Power Input: 120/208 volt, three phase, 60 Hz, four
wire, or 120/208 volt, three phase, 400 Hz,
four wire

Current: Maximum 50 amperes per phase

C. DC Power Supply:

Input Voltage: 230 VAC single phase

(Input voltage supplied by Autotransformer)

Input Frequency: 60 Hz or 400 Hz

Output Voltage: Adjustable from 20 to 40 VDC
(Maximum of 50 amperes continuous duty)

D. Shielding (Expanded):

<u>Frequency (MHz):</u>	<u>Shielding Effectiveness (dB):</u>
400	70
1200	68
5000	55
3100	58
5000	48

It is important to note that the above data reflects the lowest numbers (dB) obtained during tests on the shelters after all modifications were made, i.e., air conditioner, power input, and RF panel openings.

E. Frequency Converter:

Input Voltage: 120/208, three phase
Input Frequency: 400 Hz
Output Voltage: 120 VAC, single phase
Output Frequency: 60 Hz

F. Air Compressor:

Rated Horsepower: 1/2 Horsepower
Weight: 60 pounds
Output: 60 lbs/sq in
Input Power: 115 volts, 60 Hz, single phase
Features: Check valve and shutoff valve at tank outlet

G. U FACTOR (overall heat transfer):

.35 BTU/Hr/Sq Ft/Degree F.

VII GENERAL MISCELLANEOUS CHARACTERISTICS:

A. Mobilizer:

Each shelter is equipped with M-720 Dolly Set attachment hardware to facilitate mounting to the Dolly Set. Mounting of the Dolly Set (Figure 10) can be accomplished both with or without the leveling jacks being in place. Additionally, the shelters are capable of being transported in the bed of an M-35 truck.

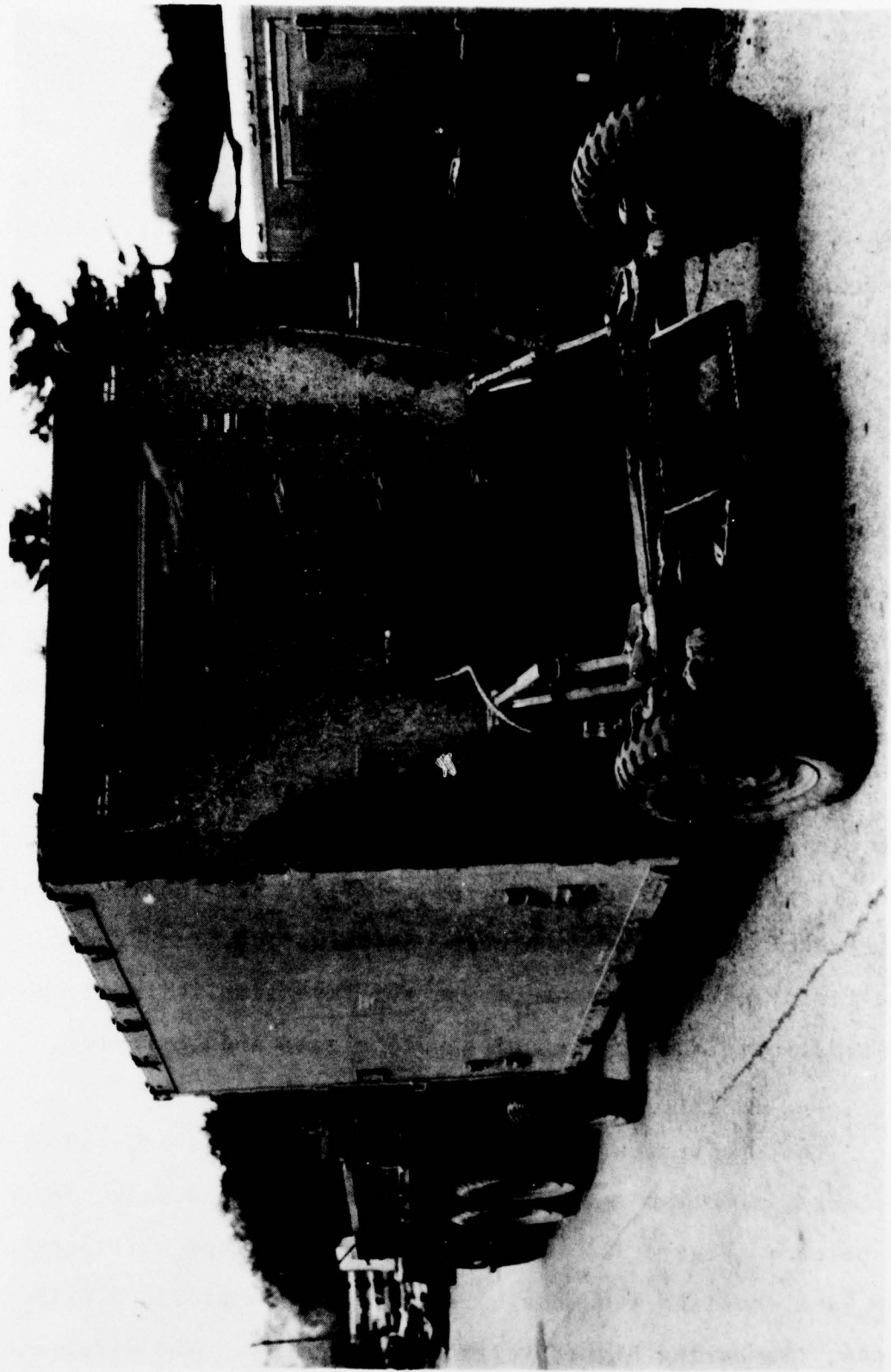

FIGURE 10 - MOUNTING OF THE DOLLY SET

B. Altitude Pressure Equilization:

An automatic device is provided in the personnel doors of the Repair Shelter and the Supply Shelter. This device allows pressure equalization between the inside and the outside of the shelters during air transport for elevation changes up to 10,000 feet per minute to and from altitudes of 50,000 feet.

C. Humidity Indicators:

External monitoring of humidity levels inside the shelters is made possible through the use of humidity indicators located in the personnel doors. Discoloration of the indicator, as viewed from outside the shelters, shows evidence of the amount of humidity within the shelters and alerts personnel to the fact that desiccant must be changed or added to prevent corrosion.

D. Shelter Repair Kit:

Maintenance of the Shelter Complex is accomplished through the use of repair kits, furnished with each shelter. These kits contain all of the necessary raw materials and tooling required to conduct repairs of punctures, delamination, leaks, etc., at the field level. Because of the relative simplicity of the design, most malfunctions may be quickly localized and corrected.

E. Shelter Complex Setup:

The shelters are designed to expand into a complex of three shelters, from two shelters, and may be operated on slopes up to 10 percent (Figure 11). The degree of the slope will determine the jack leveling sequence. Each shelter is provided with four jacks, two having higher vertical capability. The direction of

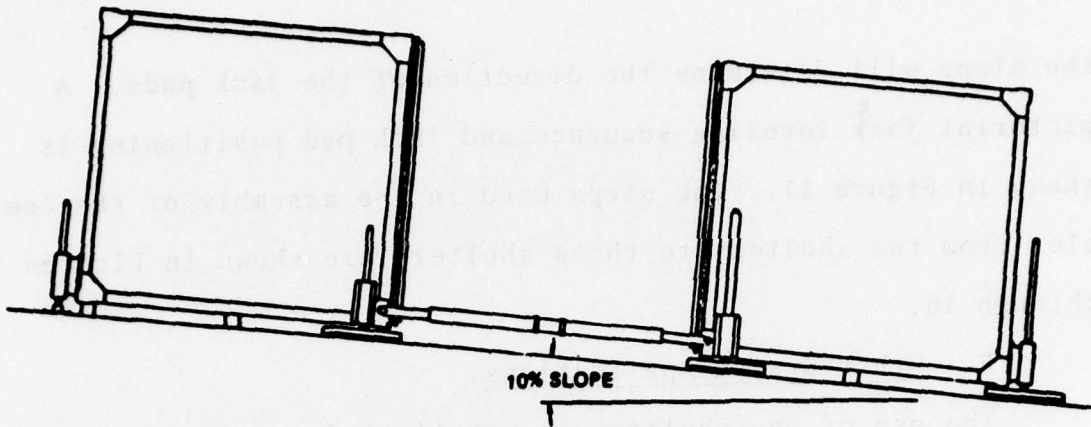

SEQUENCE 1

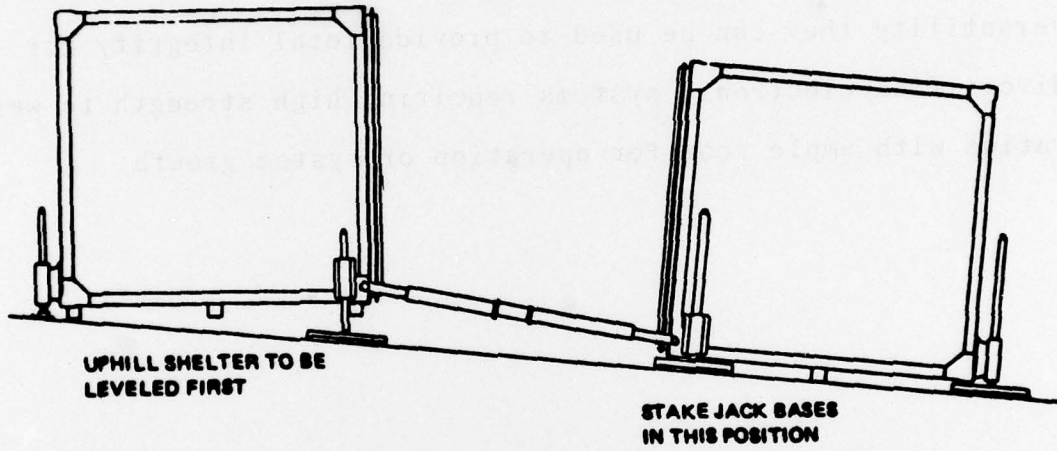

SEQUENCE 2

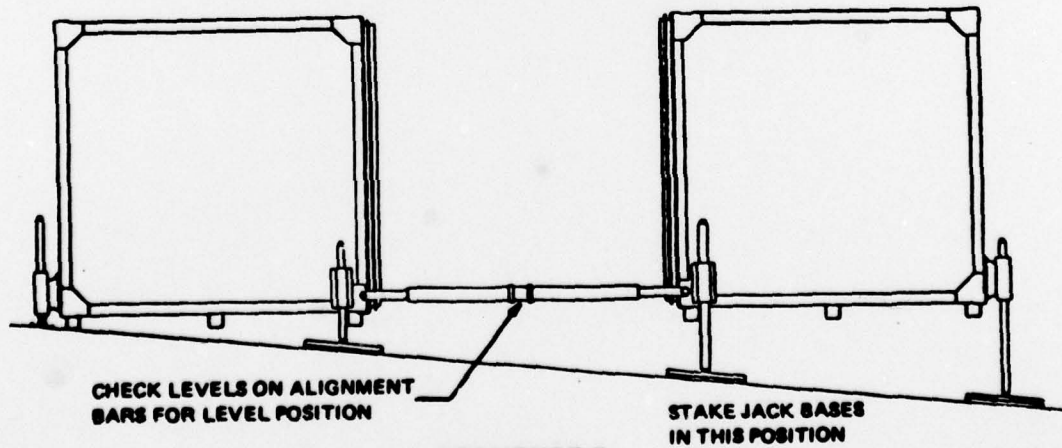

SEQUENCE 3

FIGURE 11 - JACK LEVELING SEQUENCE

the slope will determine the direction of the jack pads. A pictorial jack leveling sequence and jack pad positioning is shown in Figure 11. The steps used in the assembly of the complex from two shelters to three shelters are shown in Figures 12 through 16.

F. Other System Applications:

The use of the shelters is not limited to maintenance facilities as depicted in this report, but because of their versatility they can be used to provide total integrity for diversified electronic systems requiring high strength to weight ratios with ample room for operation or system growth.

STEP 1

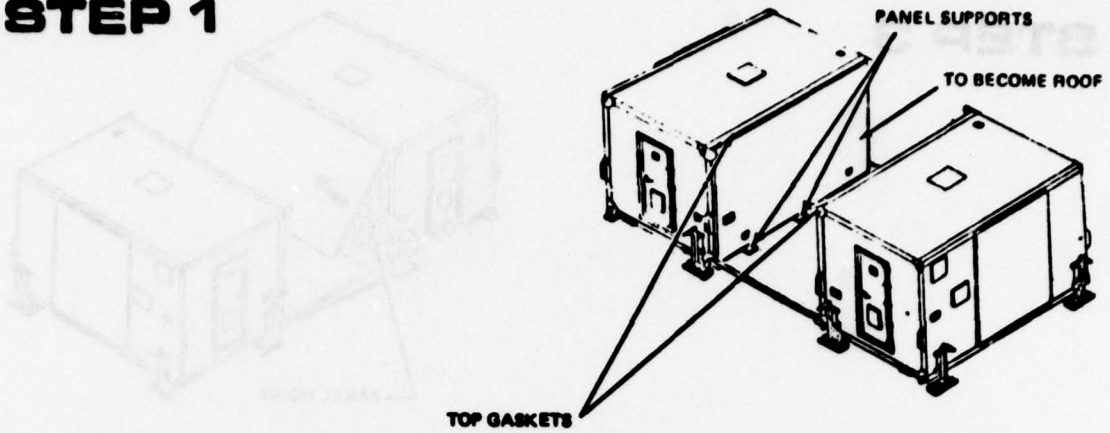

STEP 2

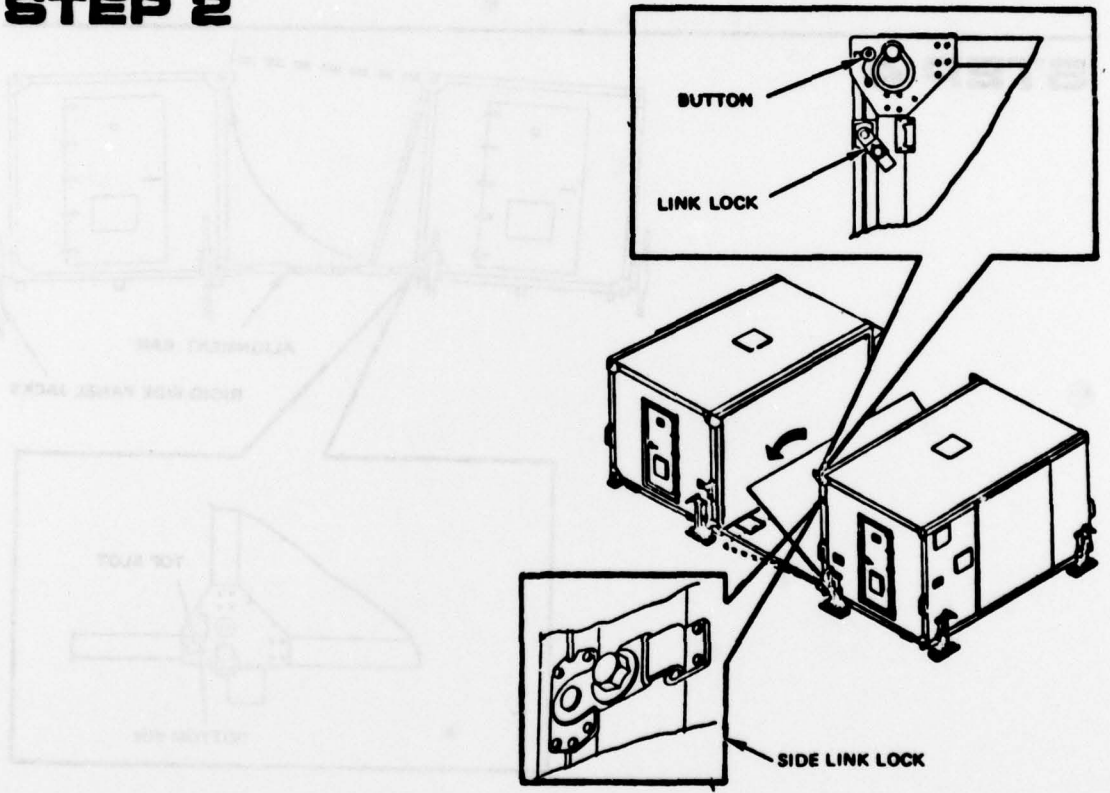
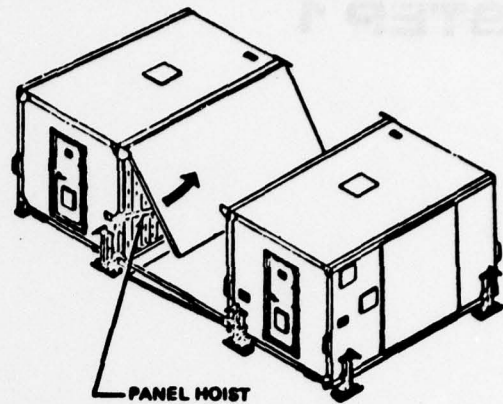

FIGURE 12 - SHELTER COMPLEX DEPLOYMENT

STEP 3



STEP 4

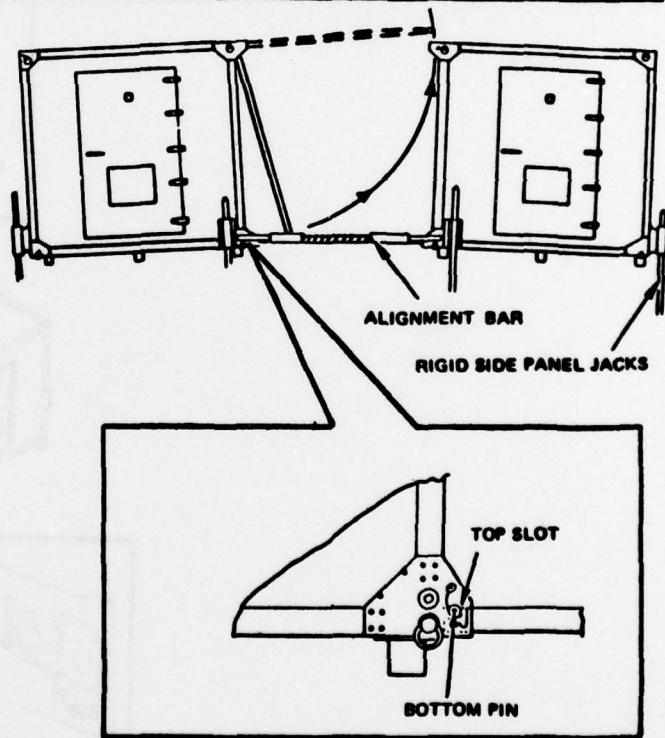
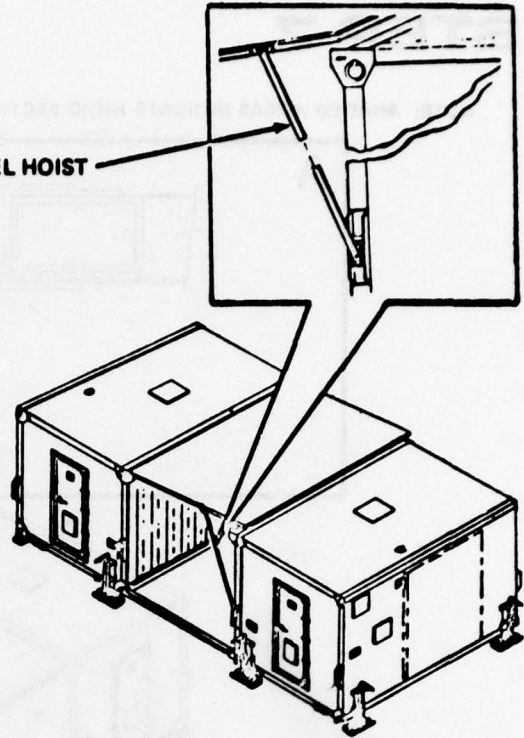

FIGURE 13 - SHELTER COMPLEX DEPLOYMENT

STEP 5

PANEL HOIST



STEP 6

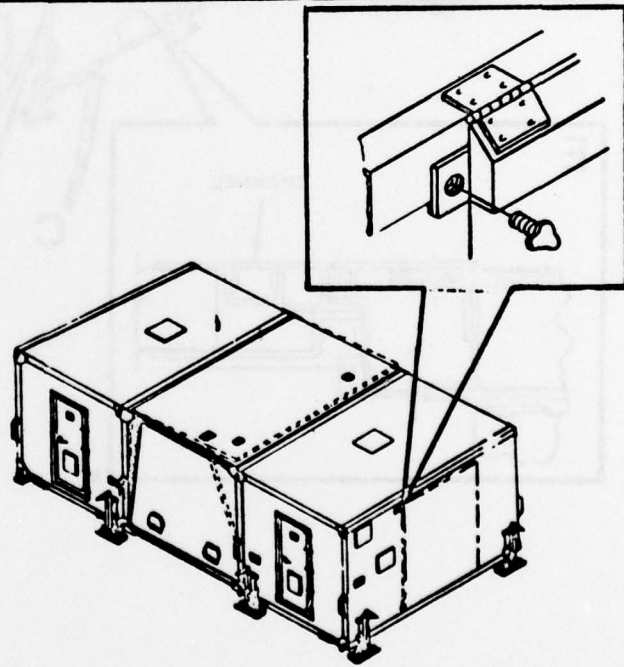

FIGURE 14 - SHELTER COMPLEX DEPLOYMENT

STEP 7

NOTE: SHADED AREAS INDICATE RIGID SECTION OF SHELTERS.

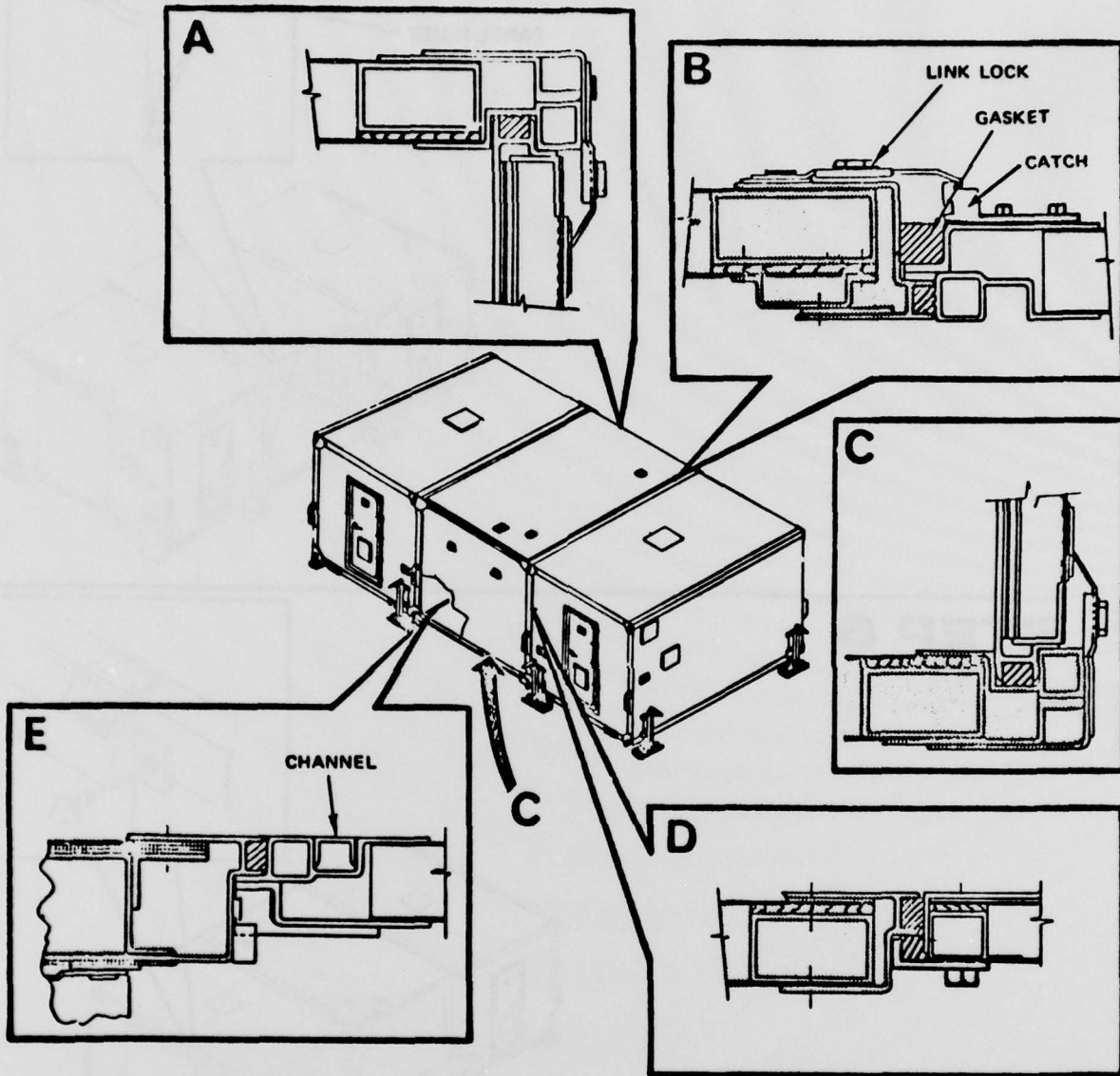

FIGURE 15 - SHELTER COMPLEX DEPLOYMENT

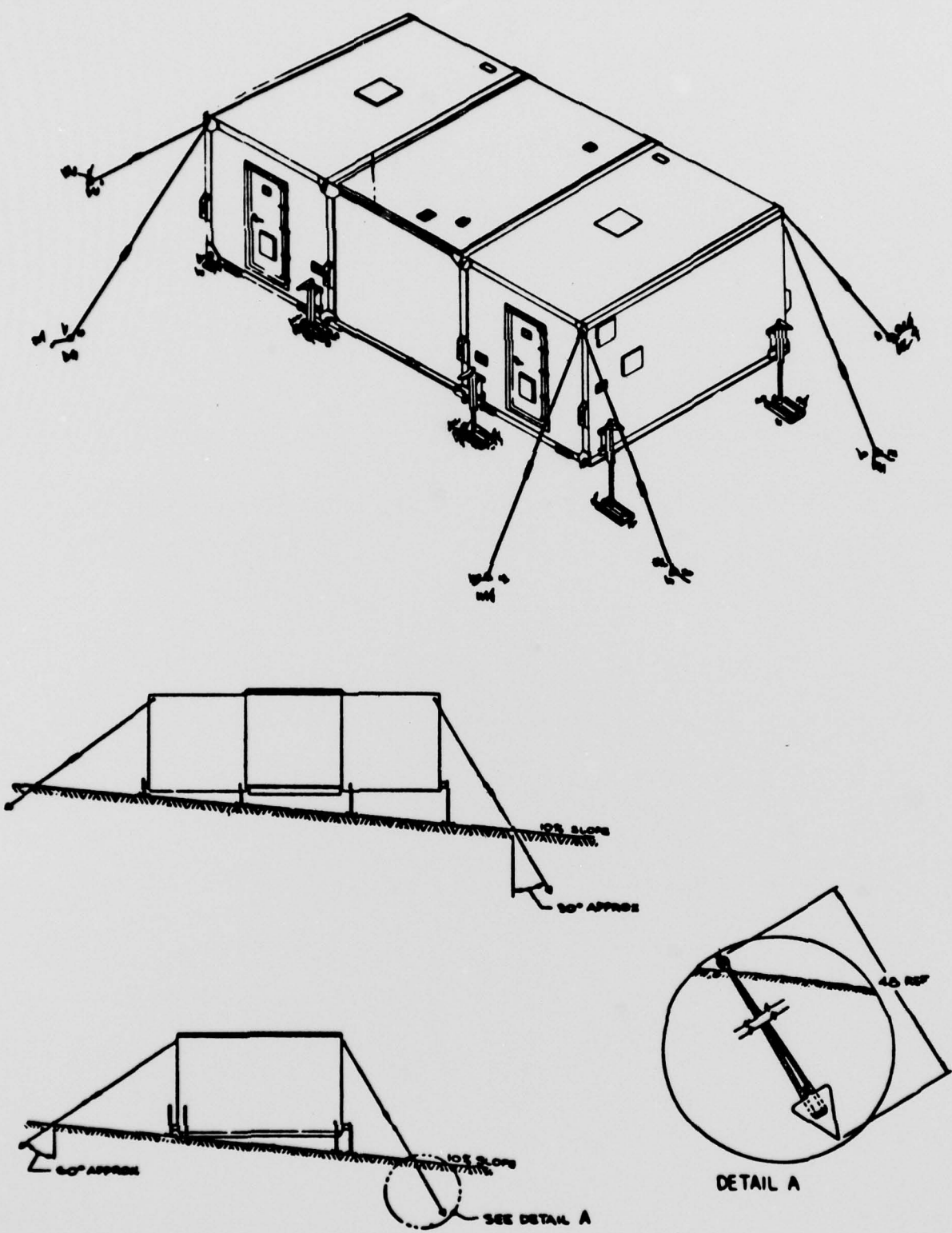

FIGURE 16 - SHELTER COMPLEX TIEDOWN