

ARO 13448.12-L<sup>v</sup>

**LEVEL II**

12  
SC

QUANTIFICATION AND MEASUREMENT OF INTERNAL  
ELECTROMAGNETIC FIELDS INDUCED IN FINITE BIOLOGICAL  
BODIES BY NONUNIFORM ELECTROMAGNETIC FIELDS

Final Report

Kun-Mu Chen

October 15, 1978

U. S. Army Research Office

Grant DAAG 29-76-G-0201

DDC  
RECEIVED  
DEC 7 1978  
E

Division of Engineering Research,  
Michigan State University  
East Lansing, Michigan 48824

Approved for Public Release  
Distribution Unlimited

78 12 04.010

DAAG 61892

DDC FILE COPY

THE FINDINGS IN THIS REPORT ARE NOT TO BE  
CONSTRUED AS AN OFFICIAL DEPARTMENT OF THE  
ARMY POSITION, UNLESS SO DESIGNATED BY OTHER  
AUTHORIZED DOCUMENTS.

6

QUANTIFICATION AND MEASUREMENT OF INTERNAL ELECTROMAGNETIC FIELDS INDUCED IN FINITE BIOLOGICAL BODIES BY NONUNIFORM ELECTROMAGNETIC FIELDS.

(9)) Final Report. 9 Apr 76 - 30 Sep 78,

(10) Kun-Mu/Chen

(11) 15 Oct ~~1978~~ 78

(12) 17 p. 1

U. S. Army Research Office

Grant DAAG 29-76-G-0201

(15)

(16) ARO | (14) 13/48, 127

Division of Engineering Research  
Michigan State University  
East Lansing, Michigan 48824

Approved for Public Release  
Distribution Unlimited

401 086

78 12 04.010 mt

REPORT DOCUMENTATION PAGE		READ INSTRUCTIONS BEFORE COMPLETING FORM
1. REPORT NUMBER Final Report	2. GOVT ACCESSION NO.	3. RECIPIENT'S CATALOG NUMBER
4. TITLE (and Subtitle) QUANTIFICATION AND MEASUREMENT OF INTERNAL ELECTROMAGNETIC FIELDS INDUCED IN FINITE BIOLOGICAL BODIES BY NONUNIFORM ELECTRO-MAGNETIC FIELDS		5. TYPE OF REPORT & PERIOD COVERED Final Report--April 9, 1976 to Sept. 30, 1978
7. AUTHOR(s) Kun-Mu Chen		6. PERFORMING ORG. REPORT NUMBER
9. PERFORMING ORGANIZATION NAME AND ADDRESS Division of Engineering Research Michigan State University East Lansing, Michigan 48824		8. CONTRACT OR GRANT NUMBER(s) DAAG 29-76-G-0201
11. CONTROLLING OFFICE NAME AND ADDRESS U. S. Army Research Office P.O.Box 12211 Research Triangle Park, NC 27709		10. PROGRAM ELEMENT, PROJECT, TASK AREA & WORK UNIT NUMBERS P-13448-L
14. MONITORING AGENCY NAME & ADDRESS (if different from Controlling Office)		12. REPORT DATE October 15, 1978
		13. NUMBER OF PAGES 13
		15. SECURITY CLASS. (of this report) unclassified
		15a. DECLASSIFICATION/DOWNGRADING SCHEDULE
16. DISTRIBUTION STATEMENT (of this Report) Approved for public release; distribution unlimited.		
17. DISTRIBUTION STATEMENT (of the abstract entered in Block 20, if different from Report) NA		
18. SUPPLEMENTARY NOTES The findings in this report are not to be construed as an official Department of the Army position, unless so designated by other authorized documents.		
19. KEY WORDS (Continue on reverse side if necessary and identify by block number) Induced EM field in human body, implantable EM field probe, interaction of antenna and human body, EM local heating, hyperthermia.		
20. ABSTRACT (Continue on reverse side if necessary and identify by block number) A theoretical method based on the numerical solution of a tensor integral equation was developed to quantify the internal EM fields induced in finite heterogeneous biological bodies by nonuniform impressed EM fields. An experimental study was also conducted to develop and study implantable EM field probes which can be used to measure the internal EM fields induced in simulated biological bodies. Major topics of this program include: (1) implantable		

electric field probes, (2) the interaction of near zone field of an antenna with human body, (3) theoretical and experimental studies on the induced EM fields inside human bodies, and (4) EM local heating for hyperthermia cancer therapy.

ACCESSION No		
DTIC	White Section	<input checked="" type="checkbox"/>
DDI	Staff Section	<input type="checkbox"/>
UNANNOUNCED		<input type="checkbox"/>
JUSTIFICATION.....		
BY.....		
DISTRIBUTION/AVAILABILITY CODES		
Dist.	AVAIL. Num/yr	SPECIAL
A		

unclassified

This is the final report on the research program, "Quantification and measurement of internal electromagnetic fields induced in finite biological bodies by nonuniform electromagnetic field," supported by the Army Research Office under Grant DAAG29-76-G-0201.

The purpose of this research program was to develop a theoretical method based on the numerical solution of a tensor integral equation to quantify the internal EM fields induced in finite, heterogeneous biological bodies by nonuniform impressed EM fields. An experimental study was to be conducted to develop and study implantable EM field probes which can be used to measure the internal EM fields induced in simulated biological bodies with a high degree of accuracy.

Most of the originally planned topics have been completed, and the study has also led to a new area of EM local heating for hyperthermia cancer therapy. Major topics of this program are (1) implantable electric field probes, (2) the interaction of near zone field of an antenna with human body, (3) theoretical and experimental studies on the induced EM fields inside human bodies, and (4) EM local heating for hyperthermia. Significant findings of each of these topics will be briefly described below.

## 1. BRIEF OUTLINE OF RESEARCH FINDINGS

### 1.1. Implantable Electric Field Probes

An ideal probe for measuring the electric field inside a finite, heterogeneous biological body should possess a constant calibration factor; probe effective length and equivalent impedance must therefore be independent of its location in the body. In order to understand characteristics of such a probe, an idealized spherical probe, insulated by a dielectric layer and immersed in a finite, lossy-dielectric body was studied theoretically and experimentally. Analytical expressions for the effective diameter and equivalent impedance of the probe were obtained. Theoretical results indicated that the variation of these parameters with probe location was minimized by coating

the probe with a relatively thick, low-permittivity dielectric layer. This conclusion was verified by experimental impedance and electric field measurements. In this study, limitations of using electric field probes were also found. Details of this study have been published in IEEE Transactions on Microwave Theory and Technique, Vol. MTT-26, Vol. 8, 599-607, August 1978.

In a separate effort, we have also developed a practical E-field probe with an interference-free lead wire system. The structure of this probe system is shown schematically in Figure 1. In this system, the section of lead wires adjacent to the probe is constructed with two series of lumped resistors of 3 K . . . The function of these resistors is to minimize the current induced on the lead wires by a strong electric field which is perpendicular to an irradiated conducting body surface. If this current induced by the surface electric field is not minimized, it will become a dominant noise component of the probe output signal. With these lumped resistors, the lead wire system becomes essentially interference-free. The probe itself is made from a zero-bias microwave diode (MA 40234) manufactured by Microwave Associates. The probe and the lead wire system are encased in a plexiglass stick with the help of epoxy glue. The probe is very rugged and inexpensive and its dimension is about 1 cm. We have used this E-field probe to measure the induced electric fields in various experimental models filled with phantom biological materials. Characteristics of this probe were reported in the 1978 International Symposium on Biological Effects of Electromagnetic Waves held on July 31 to August 8, 1978, in Helsinki, Finland.

#### 1.2. Interaction of Near Zone Field of an Antenna with Human Body

When a human body is in the proximity of an antenna, the situation leads to two problems. The problem of EM fields induced in the body and its potential biological hazard, and the problem of the proximity effects of the body on the performance of the antenna.

Our first study on the coupling between nonuniform near-zone EM fields of a small, thin wire antenna and a finite biological

body was conducted based on a simple assumption of sinusoidal antenna current. Results of this study have been published in IEEE Transactions on Antennas and Propagation, Vol. AP-25, No. 6, 863-866, November 1977.

To improve the accuracy of theoretical results, a new numerical method based on two coupled integral equations for the induced electric field in the body and the induced current on the antenna was developed recently. Based on this method the antenna and the body were considered as a single coupled system which was driven by a generator connected at a certain location on the antenna. New results have been generated and they have been presented at the 1978 IEEE International Antenna Symposium held in Washington in May 1978. Samples of these new results are shown in Figures 2 and 3.

In Figure 2, theoretically predicted antenna impedances, as a function of antenna-body spacing, are compared with corresponding measured impedances for an antenna of half-length 6.25 cm (0.125 wavelength), and a saline solution model of 25x6.25x1.56 cm. A generally good agreement between theory and experiment was obtained. This indicates the validity and accuracy of our new numerical method for solving two coupled integral equations for the antenna current and the induced electric field inside the body.

Figure 3 indicates a comparison between theoretically-predicted and experimentally-measured induced electric-field distributions in the same body of half-height 12.5 cm irradiated at 600 MHz by a quarter-wavelength (12.5 cm) monopole antenna at 4.5 cm spacing. A phantom-model body with the indicated electrical parameters was used for the experimental study. Electric fields induced in the body were measured using an implantable electric-field probe. Predicted fields induced in the two columns of cells comprising one quadrant of the body are compared with measured fields in this figure; both tabular and graphical comparison are indicated. Again the theoretical predictions conform very closely with experimentally measured data.



### 1.3. Theoretical and Experimental Studies on the Induced EM Fields Inside Human Bodies

A numerical method, called the tensor integral equation method, developed by our group has been used to quantify the internal electric field and the specific absorption rate (SAR) of EM energy induced inside human bodies irradiated by EM waves of up to 500 MHz. It was found theoretically that the induced SARs inside the body depends, among many factors, strongly on the body geometry and the frequency and polarization of incident EM wave. In many cases, hot spots are induced in narrow regions of the body, such as the neck, legs and arms. Numerical results based on a simple model of man were published in IEEE Transactions on Microwave Theory and Techniques, Vol. MTT-25, No. 9, 764-756, September 1977. Later on, another set of numerical results based on a realistic model of man was published in the Journal of Microwave Power, 12(2), 173-183, November 1977. Some sample results are shown in Figure 4.

To verify the theoretical results generated by our group on the induced EM fields inside the human body, we have conducted an experimental study to directly measure the induced electric field inside a phantom model of man with the implantable E-field probe as shown in Figure 1. A qualitative agreement was obtained between theory and experiment. The main cause of discrepancy between theory and experiment was believed to be due to numerical inaccuracy which could only be improved by subdividing the body into many more subcells. It is felt that even though our published theoretical results on the induced EM fields inside a human body may not be very accurate, they are sufficient for practical applications. An example showing the comparison between theoretical and experimental results on the induced electric fields inside a phantom model of man is given in Figure 5.

### 1.4. EM Local Heating for Hyperthermia

A study has been conducted to investigate effective methods of inducing hyperthermia in the tumors embedded in animal and human bodies by utilizing EM fields. Biological bodies with tumors were exposed to the part- or whole-body irradiation with

a uniform electric field of the HF range, the part-body irradiation with a microwave in the waveguide system, and the whole-body irradiation with a UHF EM wave in the air. The effective local EM heating of the tumor was found to depend on (1) the type of EM irradiation; part-body or whole-body, (2) the frequency of the EM field, (3) the type of applied field; electric, magnetic or electromagnetic, (4) the location of the tumor in the body, (5) the conductivity and permittivity of the tumor relative to that of the surrounding tissues, and (6) the heat dissipation from the tumor. A scheme of utilizing a non-uniform EM field to achieve an effective local heating was also investigated.

Results of this study have been published in the following papers: (1) "Focal hyperthermia as induced by RF radiation of simulacra with embedded tumors and as induced by EM fields in a model of a human body," Radio Science, Vol. 12, Vol. 6(S), 27-37, Nov.-Dec. 1977; (2) "Hyperthermia in animal and human bodies induced by EM fields," Journal of Bioengineering, Vol. 1, 531-539, 1977; and (3) "Hyperthermia by local EM heating and local conductivity change," IEEE Trans. on Biomedical Engineering, Vol. BME-24, No. 5, 473-477, September 1977. A sample example of our results is given in Figure 6.

## 2. LIST OF PUBLISHED AND SUBMITTED PAPERS

1. K.M.Chen and B. G. Guru, "Internal EM fields and absorbed power density in human torsos induced by 1-500 MHz EM waves," IEEE Trans. on Microwave Theory and Techniques, Vol. MTT-25, No. 9, 746-756, September 1977.
2. B. S. Guru and K. M. Chen, "Hyperthermia by local EM heating and local conductivity change," IEEE Trans. on Bio-medical Engr, Vol. BME-24, No. 5, p. 473-477, September 1977.
3. D. P. Nyquist, K. M. Chen, and B. S. Guru, "Coupling between small thin-wire antennas and a biological body," IEEE Trans. on Antennas and Prop., Vol. AP-25, No. 6, 863-866, November 1977.
4. K. M. Chen and B. S. Guru, "Induced EM fields inside human bodies irradiated by EM waves of up to 500 MHz," Journal of Microwave Power, Vol. 12, No. 2, 173-183, 1977.

5. K. M. Chen and B. S. Guru, "Focal hyperthermia as induced by RF radiation of simulacra with embedded tumors and as induced by EM fields in a model of a human body," Radio Science, Vol. 12, Vol. 6(S), 27-37, Nov.-Dec. 1977.

6. K. M. Chen and S. Rukspollmuang, "Hyperthermia in animal and human bodies induced by electromagnetic fields," Journal of Bioengineering, Vol. 1, No. 5/6, 531-539, December 1977.

7. H. Mousavinezhad, K. M. Chen and D. P. Nyquist, "Response of insulated electric field probes in finite heterogeneous biological bodies," IEEE Trans. on Microwave Theory and Techniques, Vol. MTT-26, No. 8, 599-607, August 1978.

8. K. M. Chen, H. Mousavinezhad, S. Rukspollmuang and D. P. Nyquist, "Induced EM field inside human bodies and human heads," presented at 1977 International Symposium on Biological Effects of EM Waves, October 1977, Airlie, Virginia.

9. K. M. Chen and S. Rukspollmuang, "RF applications for inducing hyperthermia in embedded tumors," presented at 1977 International Symposium on Biological Effects of EM waves, October 1977, Airlie, Virginia.

10. K. M. Chen and S. Rukspollmuang, "Hyperthermia in animal and human bodies induced by EM fields," presented at Workshop on Electromagnetics and Cancer held in conjunction with IEEE-MTT Symposium in San Diego, California, June 1977.

11. K. Karimullah, D. P. Nyquist and K. M. Chen, "Interaction of thin-wire antennas with conducting polarizable bodies: theory and experiment," presented at 1978 International IEEE/AP-S Symposium, May 15-19, 1978, Washington, D.C.

12. K. M. Chen, S. Rukspollmuang and D. P. Nyquist, "Measurement of induced electric fields in a phantom model of man," presented at International Symposium on Biological Effects of Electromagnetic Waves held on July 31 to August 8, 1978, in Helsinki, Finland.

### 3. SCIENTIFIC PERSONNEL PARTICIPATING IN THIS PROJECT

- (1) Dr. Kun-Mu Chen, Professor and Principal Investigator.
- (2) Dr. Dennis P. Nyquist, Associate Professor and Co-Principal Investigator
- (3) B. S. Guru, Graduate Assistant, not supported financially by this grant and was graduated with Ph.D. in September 1976.

- (4) H. Mousavinezhad, graduate with Ph.D. in September 1977
- (5) Khalid Karimullah, Graduate Assistant
- (6) Jen-Hwang Lee, Graduate Assistant, partially supported by this grant
- (7) Sutus Rukspollmuang, Graduate Assistant, partially supported by this grant

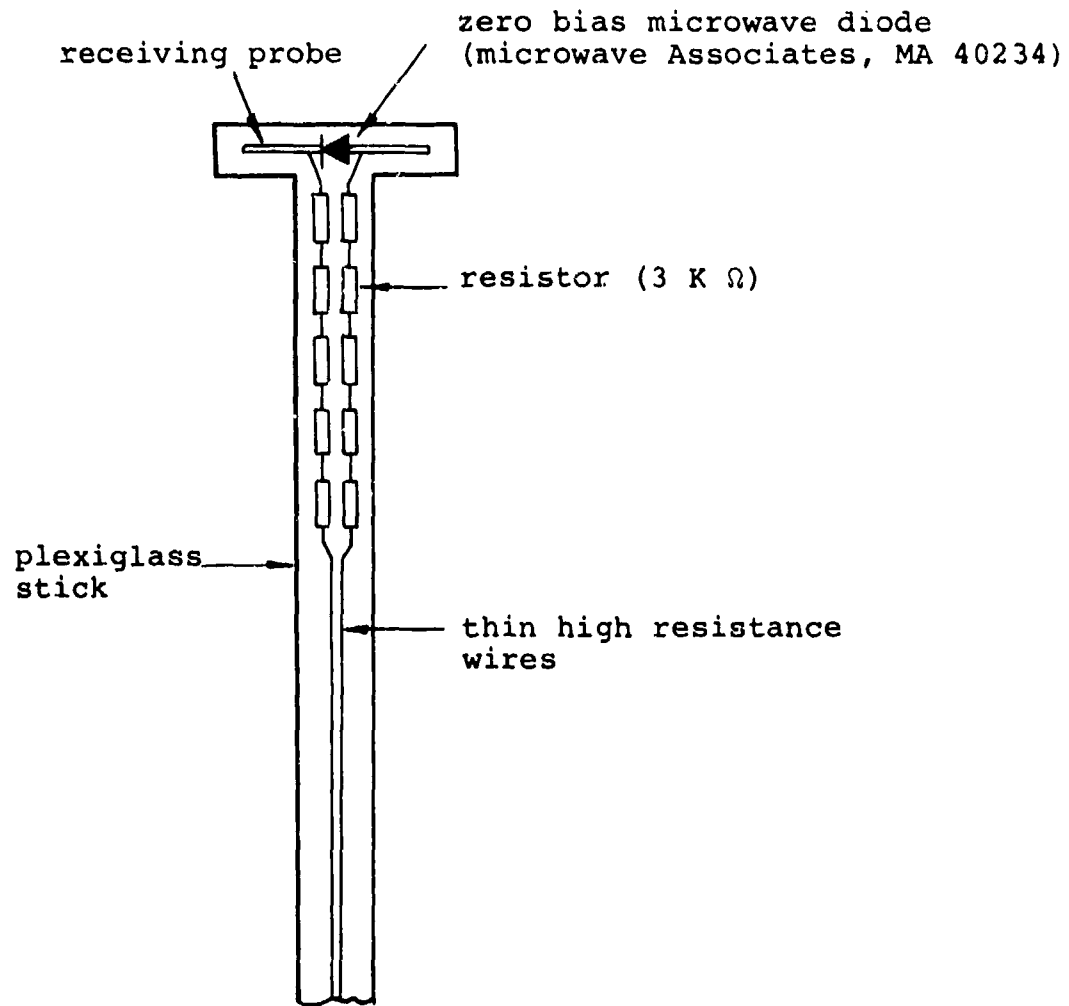
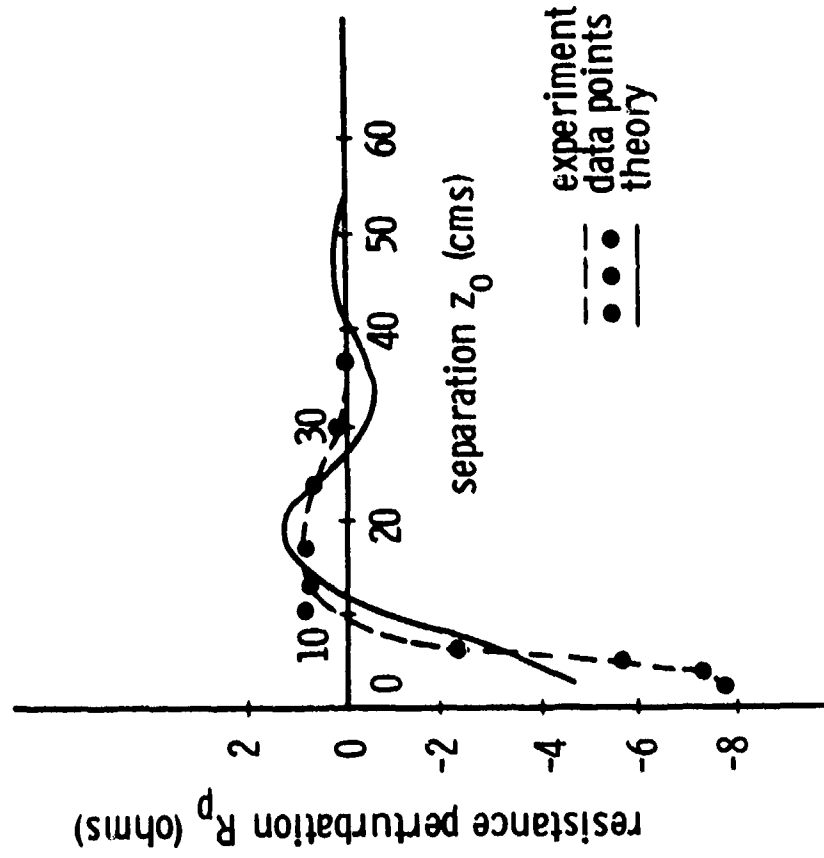
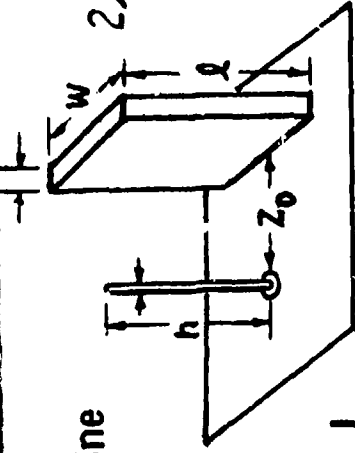

Figure 1 A non-interfering, electric field probe for measuring the induced electric field in a biological body.

$f = 600 \text{ MHz}$   
 $h = 0.125 \lambda_0 = 6.25 \text{ cm}$   
 $\Omega = 2 \ln \left( \frac{2h}{a} \right) = 10$

body = 0.5N NaCl Saline  
 $\sigma = 4.44 \text{ S/m}$   
 $\epsilon_f = 71.00$

$2L = 25.0 \text{ cm}$   
 $w = 6.25 \text{ cm}$   
 $d = 1.56 \text{ cm}$



a. perturbation  $R_p$  to antenna resistance.

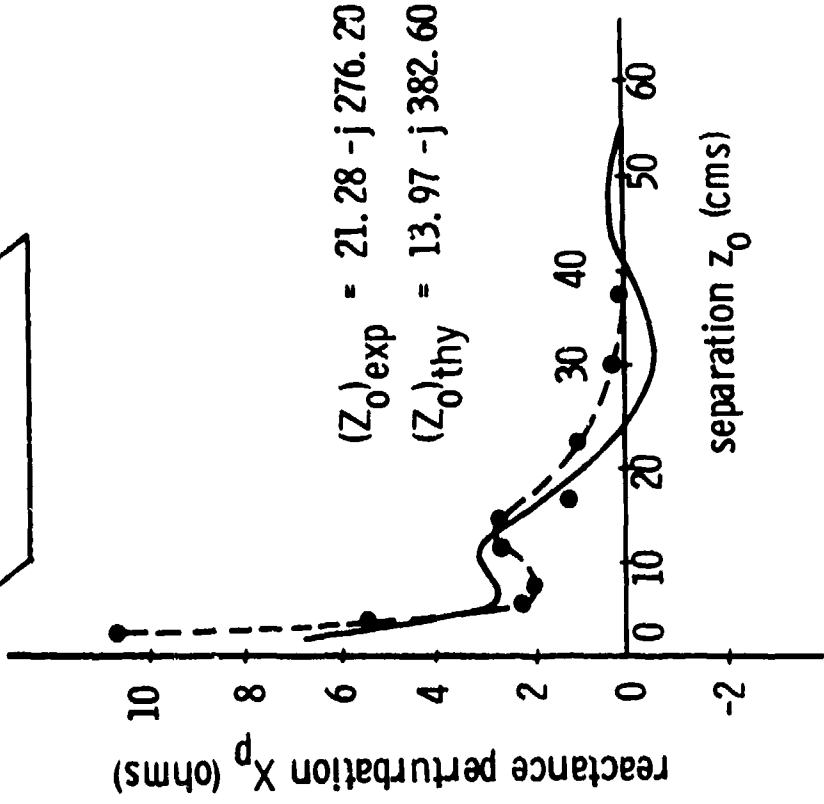

b. perturbation  $X_p$  to antenna reactance.

Figure 2 Dependence of antenna impedance  $Z_{\text{in}} = Z_0 + Z_p$  ( $Z_0$  = free-space impedance,  $Z_p$  = perturbation due to body proximity effect) upon antenna-body spacing  $z_0$ .

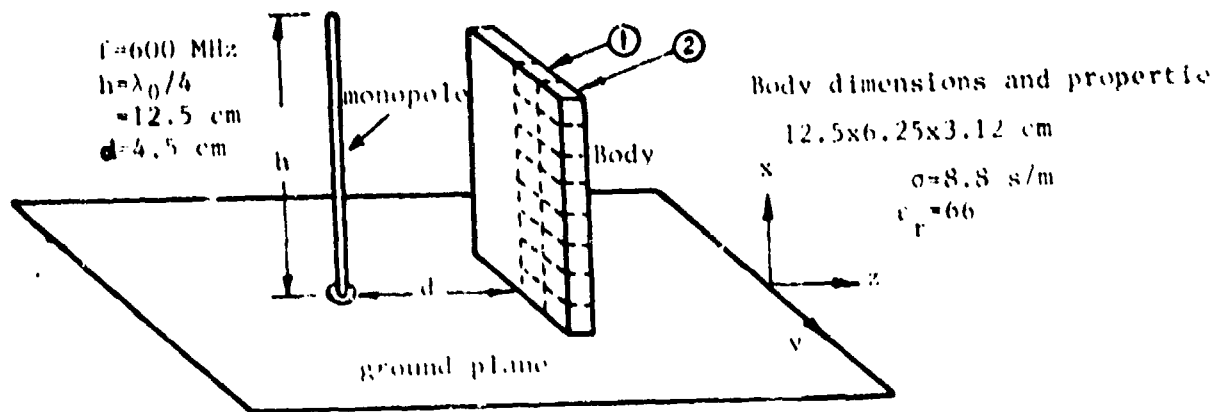

(Theory)

①	②
0.18	0.21
0.33	0.38
0.47	0.53
0.60	0.68
0.71	0.80
0.80	0.90
0.86	0.97
0.88	1.0

relative distribution of  $|E_x|$  in the body

(Experiment)

①	②
0.22	0.27
0.30	0.37
0.48	0.65
0.59	0.84
0.72	1.0
0.74	1.14
0.85	1.21
0.97	1.3

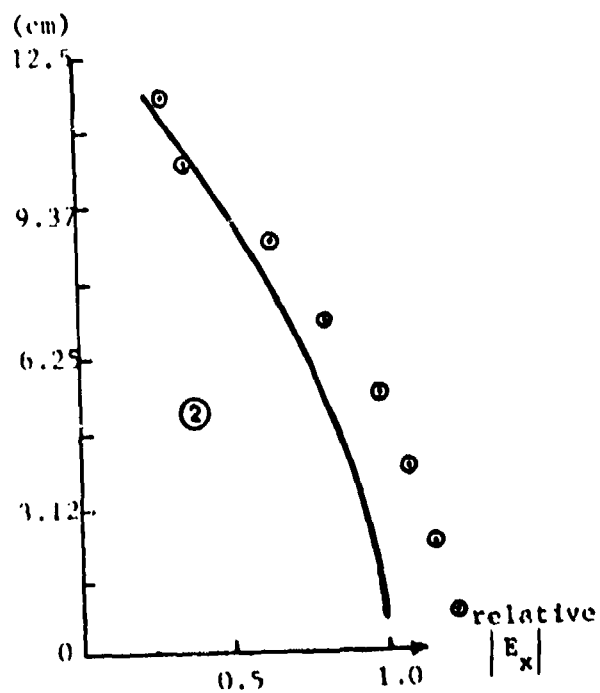
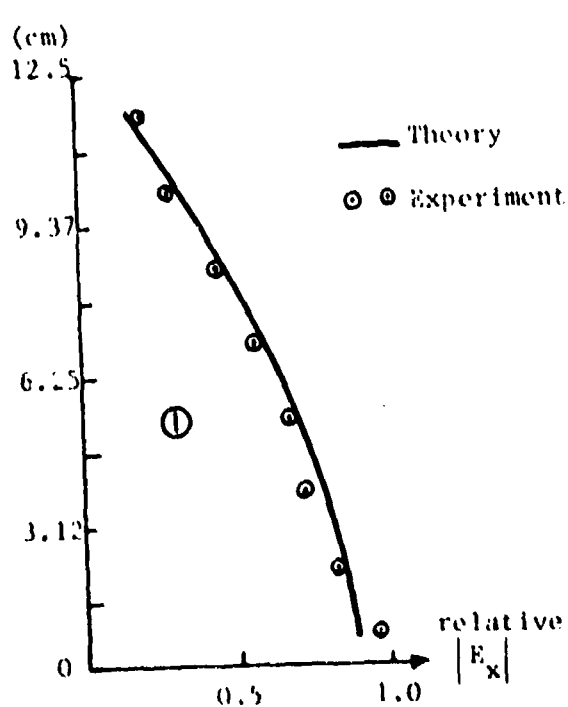
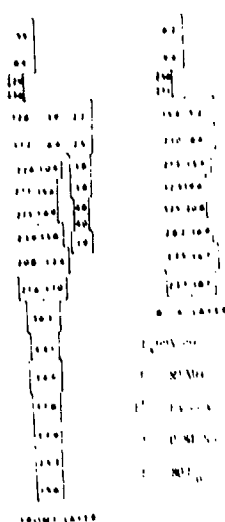
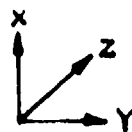
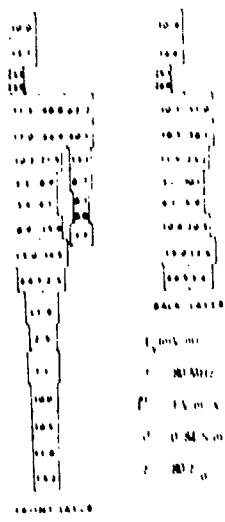

Fig. 3 Theoretical and experimental results on the x-components of the induced electrical fields in a conducting body of  $12.5 \times 6.25 \times 3.12$  cm placed at a distance of 4.5 cm from a  $\lambda_0/4$  monopole.



The x-component of induced electric field. Incident EM wave vertical polarization, 80 MHz,  $E^i = 1 \text{ V/m}$ . Body parameters:  $\sigma = 0.84 \text{ S/m}$ ,  $\epsilon = 80 \epsilon_0$ .



The y-component of induced electric field. Incident EM wave vertical polarization, 80 MHz,  $E^i = 1 \text{ V/m}$ . Body parameters:  $\sigma = 0.84 \text{ S/m}$ ,  $\epsilon = 80 \epsilon_0$ .

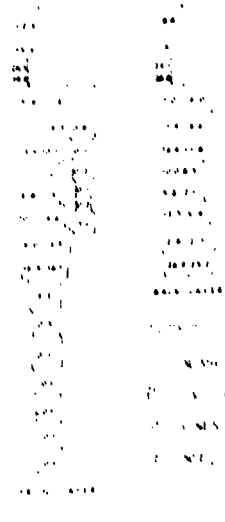

The z-component of induced electric field. Incident EM wave vertical polarization, 80 MHz,  $E^i = 1 \text{ V/m}$ . Body parameters:  $\sigma = 0.84 \text{ S/m}$ ,  $\epsilon = 80 \epsilon_0$ .

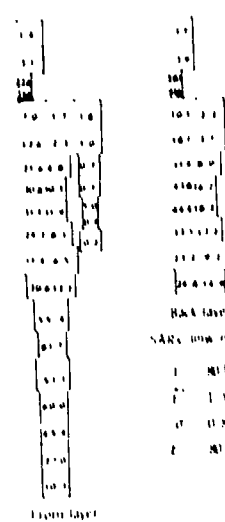

Distribution of induced SARs. Incident EM wave vertical polarization, 80 MHz,  $E^i = 1 \text{ V/m}$ . Body parameters:  $\sigma = 0.84 \text{ S/m}$ ,  $\epsilon = 80 \epsilon_0$ .

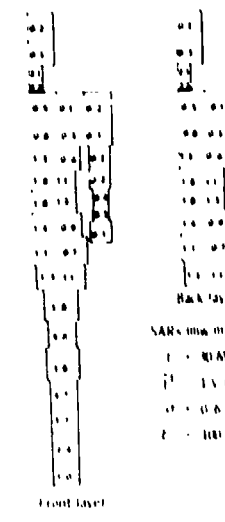

Distribution of induced SARs. Incident EM wave vertical polarization, 30 MHz,  $E^i = 1 \text{ V/m}$ . Body parameters:  $\sigma = 0.6 \text{ S/m}$ ,  $\epsilon = 100 \epsilon_0$ .

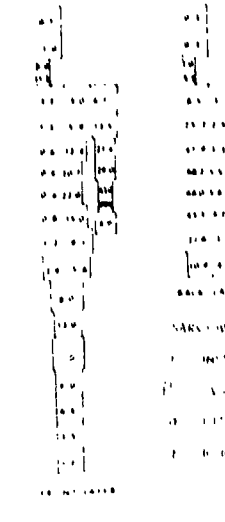

Distribution of induced SARs. Incident EM wave vertical polarization, 160 MHz,  $E^i = 1 \text{ V/m}$ . Body parameters:  $\sigma = 1.12 \text{ S/m}$ ,  $\epsilon = 62.6 \epsilon_0$ .

Fig. 4 Induced EM Fields inside a model of man with a height of 177 cm.



Relative distribution of  $E_x$   
(Experiment)

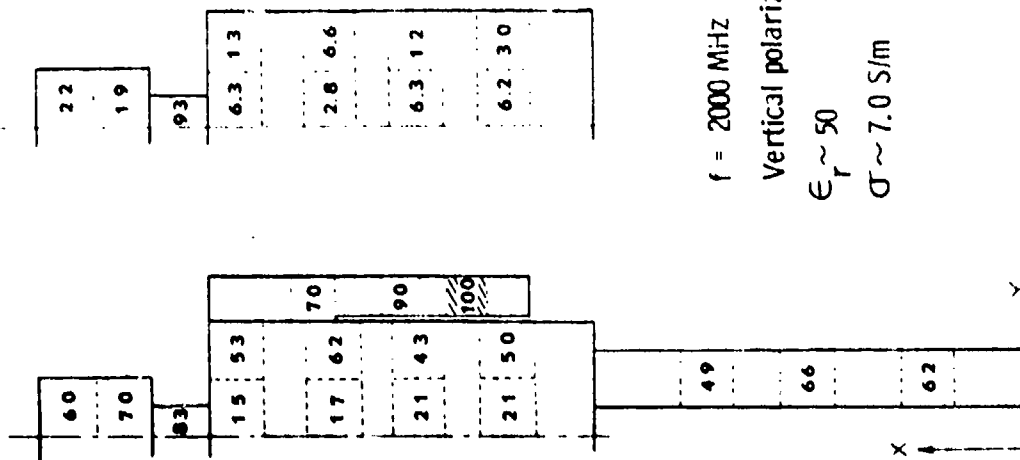

Fig. 5(a) Distribution of measured electric field in a phantom model of man (height of model = 16 cm)

Relative distribution of  $E_x$   
(Theory)

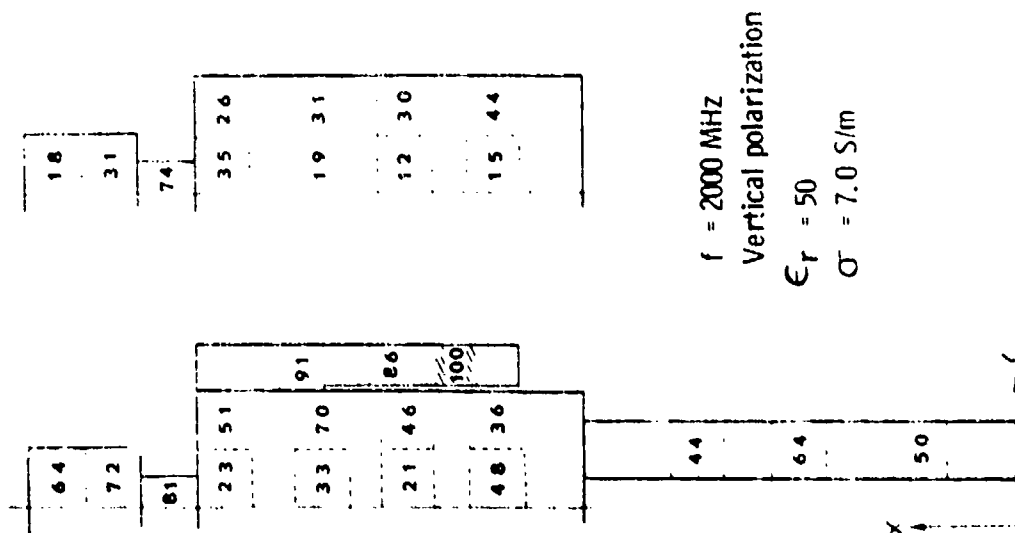

Fig. 5(b) Distribution of theoretical electric field in a phantom model of a man (height of model = 16 cm)

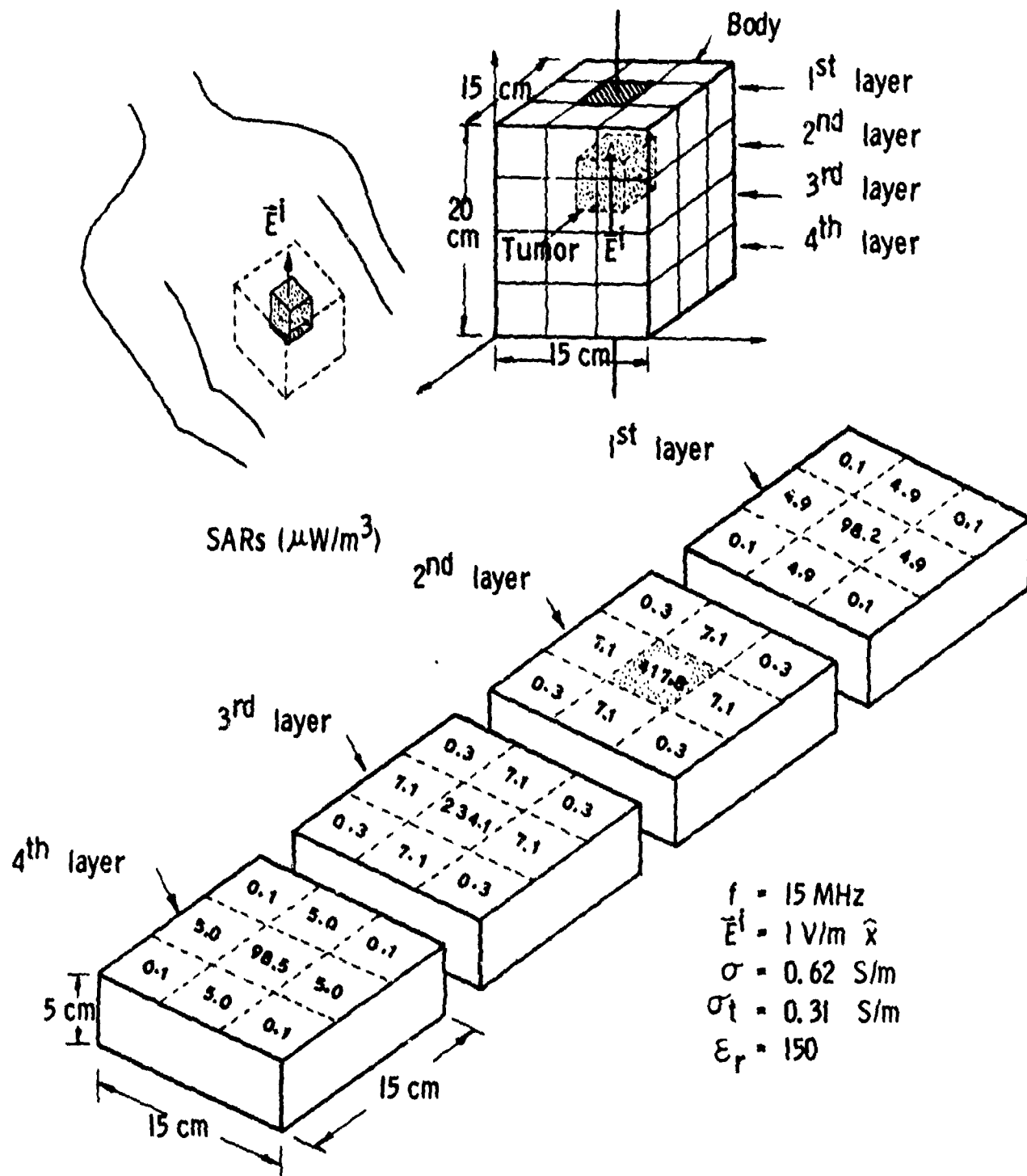

Fig. 6 Distribution of SARs induced by a beam of HF electric field in a human torso with an embedded tumor.