

AD-A061 275

NAVAL POSTGRADUATE SCHOOL MONTEREY CALIF  
AN EXPERIMENT TO MEASURE SLANT PATH EXTINCTION IN THE MARINE B0--ETC(U)  
JUN 78 D G HENDERSON

F/G 20/6

UNCLASSIFIED

NL

1 of 1  
AD  
A061 275



END  
DATE  
FILMED  
1-79  
DDC

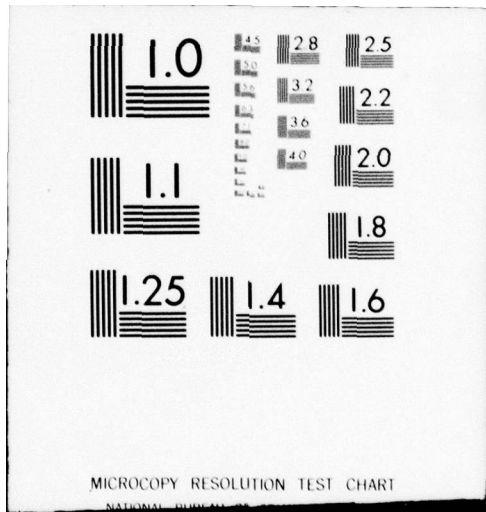

**LEVEL II**

*2*  
*NW*

**NAVAL POSTGRADUATE SCHOOL**  
**Monterey, California**

AD A061275

DDC FILE COPY



**THESIS**

AN EXPERIMENT TO MEASURE  
SLANT PATH EXTINCTION  
IN THE MARINE BOUNDARY LAYER

by

Daniel Glen Henderson

June 1978

Thesis Advisor:

E.C. Crittenden, Jr.

Approved for public release; distribution unlimited.

DDC  
RECEIVED  
NOV 17 1978  
D

78 11 13 094

UNCLASSIFIED

SECURITY CLASSIFICATION OF THIS PAGE (When Data Entered)

REPORT DOCUMENTATION PAGE		READ INSTRUCTIONS BEFORE COMPLETING FORM
1. REPORT NUMBER	2. GOVT ACCESSION NO.	3. RECIPIENT'S CATALOG NUMBER
6. TITLE (and Subtitle) An Experiment to Measure Slant Path Extinction in the Marine Boundary Layer		4. TYPE OF REPORT & PERIOD COVERED Master's Thesis June 1978
7. AUTHOR(s) Daniel Glen Henderson		5. PERFORMING ORG. REPORT NUMBER
8. PERFORMING ORGANIZATION NAME AND ADDRESS Naval Postgraduate School Monterey, California 93940		6. CONTRACT OR GRANT NUMBER(s)
9. CONTROLLING OFFICE NAME AND ADDRESS Naval Postgraduate School Monterey, California 93940		7. REPORT DATE June 1978
10. MONITORING AGENCY NAME & ADDRESS (if different from Controlling Office) 12. 44 p.		8. NUMBER OF PAGES 43
		9. SECURITY CLASS. (of this report) Unclassified
		10. DECLASSIFICATION/DOWNGRADING SCHEDULE
11. DISTRIBUTION STATEMENT (of this Report) Approved for public release; distribution unlimited.		
12. DISTRIBUTION STATEMENT (of the abstract entered in Block 20, if different from Report)		
13. SUPPLEMENTARY NOTES		
14. KEY WORDS (Continue on reverse side if necessary and identify by block number) Slant Path Extinction Marine Boundary Layer		
15. ABSTRACT (Continue on reverse side if necessary and identify by block number) An experiment to measure atmospheric extinction, along a slant path in the marine boundary layer, was devised and partially constructed. The slant path is from a kytoon, flown from a ship in motion, to a gyro-stabilized platform mounted on shipboard. The light source on the kytoon is an omnidirectional high pressure xenon flash lamp, with a quartz envelope, to provide radiation from the visible to the middle		

78 11 13 251 450



UNCLASSIFIED

SECURITY CLASSIFICATION OF THIS PAGE(When Data Entered)

(20. ABSTRACT Continued)

IR regions of the spectrum. Wavelengths of 0.4880 <sup>micrometers</sup>  $\mu\text{m}$ , 0.6328  $\mu\text{m}$ , 1.06  $\mu\text{m}$ , 1.25  $\mu\text{m}$ , 1.60  $\mu\text{m}$ , 2.20  $\mu\text{m}$ , and 3.80  $\mu\text{m}$ , are isolated by use of interference filters. The range, needed in the process of determining extinction is obtained by a ranging system composed of a GaAs pulsing laser with optics mounted on the gyro-platform on shipboard, a retro-reflecting system on the kytoon, a receiver coaxial with the transmitter on shipboard, and a HP-1743-A 100 MHz oscilloscope. The pulsed laser also triggers the flashlamp on the kytoon so that synchronous detection techniques can be utilized for extinction measurements at the receivers.

ABSTRACT OF		
DTIC	White Section <input checked="" type="checkbox"/>	
DDC	DDC Section <input type="checkbox"/>	
ORANNOUDED	<input type="checkbox"/>	
JUSTIFICATION		
BY		
DISTRIBUTION/AVAILABILITY CODES		
GOL AVAIL. and/or SPECIAL		
A		

DD Form 1473 (BACK)  
1 Jan 73  
S/N 0102-014-6601

UNCLASSIFIED  
SECURITY CLASSIFICATION OF THIS PAGE(When Data Entered)

Approved for public release; distribution unlimited.

An Experiment to Measure  
Slant Path Extinction  
in the Marine Boundary Layer

by

Daniel Glen Henderson  
Lieutenant, United States Coast Guard  
B.S., United States Coast Guard Academy, 1974

Submitted in partial fulfillment of the  
requirements for the degree of

MASTER OF SCIENCE IN PHYSICS

MASTER OF APPLIED SCIENCE

from the

NAVAL POSTGRADUATE SCHOOL

June 1978

Author

*Daniel G. Henderson*

Approved by:

*E. L. Britton*

Thesis Advisor

*E. A. Milne*

Second Reader

*J. B. Powers*

Second Reader

*H. G. Walker*

Chairman, Department of Physics and Chemistry

*W. E. Kunk*

Chairman, Department of Electrical Engineering

*William M. Tolks*

Dean of Science and Engineering

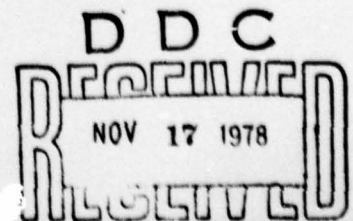

### ABSTRACT

An experiment to measure atmospheric extinction, along a slant path in the marine boundary layer, was devised and partially constructed. The slant path is from a kytoon, flown from a ship in motion, to a gyro-stabilized platform mounted on shipboard. The light source on the kytoon is an omni-directional high pressure xenon flash lamp, with a quartz envelope, to provide radiation from the visible to the middle IR regions of the spectrum. Wavelengths of 0.4880  $\mu\text{m}$ , 0.6328  $\mu\text{m}$ , 1.06  $\mu\text{m}$ , 1.25  $\mu\text{m}$ , 1.60  $\mu\text{m}$ , 2.20  $\mu\text{m}$ , and 3.80  $\mu\text{m}$  are isolated by use of interference filters. The range, needed in the process of determining extinction is obtained by a ranging system composed of a GaAs pulsing laser with optics mounted on the gyro-platform on shipboard, a retro-reflecting system on the kytoon, a receiver coaxial with the transmitter on shipboard, and a HP-1743A 100 MHz oscilloscope. The pulsed laser also triggers the flashlamp on the kytoon so that synchronous detection techniques can be utilized for extinction measurements at the receivers.



TABLE OF CONTENTS

I.	PROBLEM DESCRIPTION -----	7
	A. GENERAL -----	7
	B. MATHEMATICAL BASIS OF EXPERIMENT -----	8
	1. Extinction -----	8
	2. Scintillation Effects -----	12
II.	DESIGN OF EXPERIMENT -----	15
	A. GENERAL -----	15
	B. PROPOSED EQUIPMENT -----	18
	1. Ranging Apparatus -----	18
	2. Airborne Platform -----	31
	3. Radiation Source -----	31
	4. Tracking System -----	32
	5. Frequency Bands of Observation and Detectors -----	33
	6. Signal Processing -----	36
III.	CONCLUSIONS -----	41
	BIBLIOGRAPHY -----	42
	INITIAL DISTRIBUTION LIST -----	43

LIST OF FIGURES

1. Atmospheric Absorption -----	9
2. Proposed Slant Path Experiment -----	16
3. Monterey Bay Test Ranges -----	17
4. Ranging Equipment -----	20
5. Transmitter Schematic -----	21
6. Laser Pulser Circuit Boards -----	22
7. Laser and Adjustments -----	24
8. Response of Single Retro Reflector -----	26
9. Three-Retro Array -----	27
10. Response of Three-Retro Array -----	28
11. Isolation of 1.60 micrometer observation band --	35
12. Signal Processing Scheme Flowchart -----	37



## I. PROBLEM DESCRIPTION

### A. GENERAL

Light propagating in the atmosphere is affected by many phenomena. Depending upon the characteristics of the light which is propagated, the time dependence of the magnitude and phase of the light at a receiver leads to behavior such as beam wander and spread for highly collimated light, as well as scintillation and attenuation for all forms of light. Attenuation, or extinction, has usually been experimentally measured along paths parallel to the surface of the earth. The goal of this work is the development of an experiment which will allow the measurement of extinction along a slant path in a marine environment.

Optical extinction, due to the atmosphere, is usually the result of two processes -- absorption by the gaseous molecules of the air, and scattering and absorption due to particulates and aerosols in suspension in the atmosphere. The effects of gaseous absorption will be eliminated in this experiment by the use of known molecular absorption coefficients. The magnitude of this correction will be minimized wherever possible by use of regions of the spectrum where gaseous absorption is small. As a result the degree of extinction will be a function of the particulate and aerosol concentrations that exist at the time of observation, and these in turn depend on the meteorological conditions.

Hopefully this will allow the existing meteorological conditions to be correlated with observed extinction values. This should permit an observer to measure the meteorological conditions and successfully predict an approximate extinction value.

## B. MATHEMATICAL BASIS OF EXPERIMENT

### 1. Extinction

It was discovered by Bouguer and Lambert that layers of equal thickness of an attenuating material (solid, liquid, gas) will attenuate equal amounts of electromagnetic flux passing through them. This fact is mathematically stated in the Bouguer-Lambert Law for parallel light [Ref. 1].

$$P = P_0 e^{-\sigma x} \quad (1)$$

where

$p$  = Flux remaining after traveling a distance  $x$  in the attenuating layer

$p_0$  = Flux incident upon the attenuating layer

$\sigma$  = Extinction coefficient

$x$  = Path length in the attenuating layer

The extinction coefficient  $\sigma$  contains effects from both molecular absorption and particulate scattering. That is,  $\sigma$  is the algebraic sum of the molecular absorption coefficient ( $\alpha$ ) and the scattering coefficient ( $\gamma$ ).

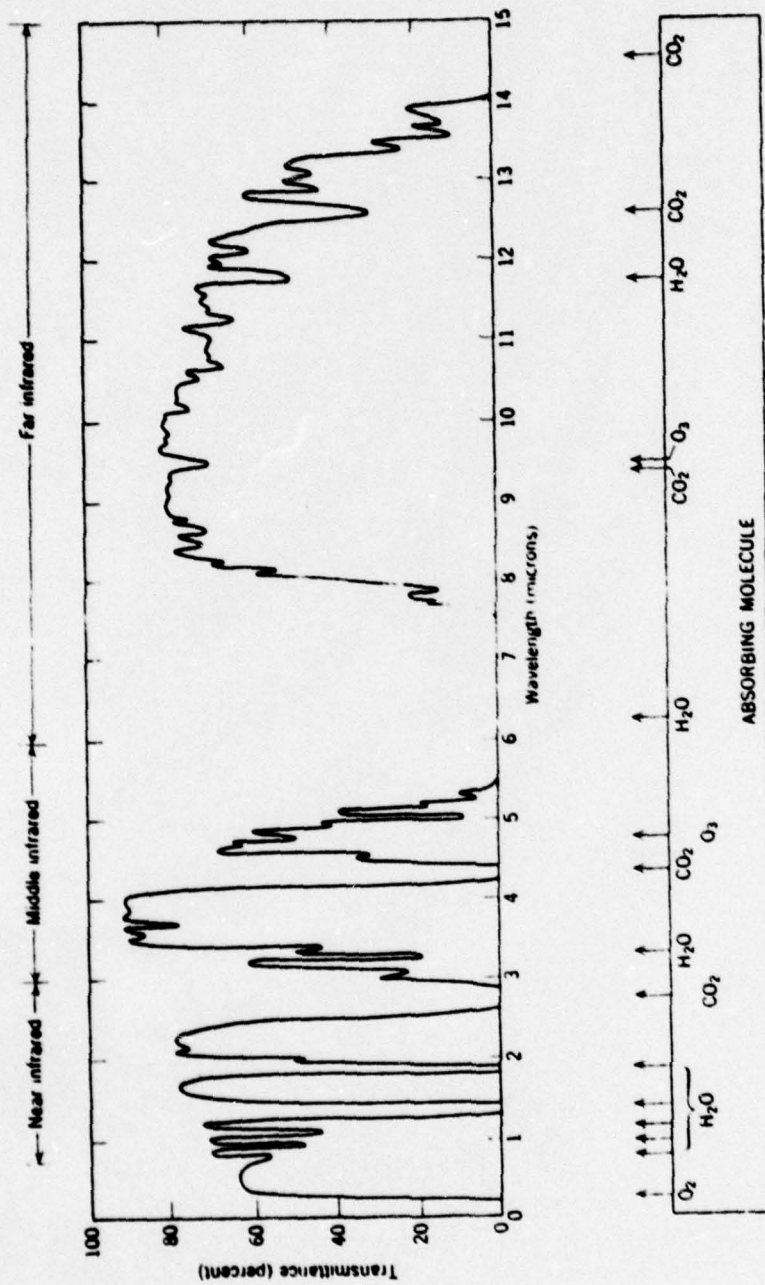

Figure 1. Absorption of the Atmosphere, 6000 ft. horizontal, sea level path [Ref. 1].



$$\sigma = \alpha + \gamma \quad (2)$$

As stated in Sect. A of this chapter, the effect of  $\alpha$  will be reduced but not altogether eliminated by using regions of the spectrum where gaseous absorption is a minimum. Since  $\gamma$  is the parameter of greatest interest the effects of  $\alpha$  must be subtracted.

The relationship described by Eq. (1) holds for plane waves. The units of flux described by the Bouguer-Lambert law are energy per unit time over a given area. Thus, considering a flash source to radiate  $p_0$  watts in a spherical wave into solid angle  $\Omega$  the irradiance  $R$  meters from the source is:

$$H = \frac{4\pi p_0 e^{-\sigma R}}{\Omega R^2} \quad (3)$$

By performing a controlled calibration test where  $R_0$  is at least three orders of magnitude less than the  $R$  of the experimental runs, and where absorption is a minimum ( $\sigma = \sigma_0$ ), a system reference can be established.

$$H_0 = \frac{p_0 e^{-\sigma_0 R_0} 4\pi}{\Omega R_0^2} \quad (4)$$

where subscript indicates control calibration run.

Then from Eq. (4)

$$\frac{4\pi P_o}{\Omega} = H_o R_o^2 e^{\sigma_o R_o} \quad (5)$$

therefore

$$H = \frac{H_o R_o^2 e^{\sigma_o R_o} e^{-\sigma R}}{R^2} \quad (6)$$

Taking the natural logarithm yields

$$\text{LN}(HR^2) = \text{LN}(H_o R_o^2 e^{\sigma_o R_o}) - \sigma R \quad (7)$$

At this point one would recognize that  $e^{\sigma_o R_o}$  is approximately equal to one, since  $\sigma_o R_o$  is much less than one when  $R_o$  is on the order of several meters. Therefore define the constant C to be evaluated during the calibration test.

$$H_o R_o^2 = C \quad (8)$$

Substituting into Eq. (6) yields

$$H = \frac{C e^{-\sigma R}}{R^2} \quad (9)$$

from which one may solve for  $\sigma$ :

$$\sigma = \frac{\text{LN}(C) - \text{LN}(HR^2)}{R} \quad (10)$$

and



From this the extinction coefficient can be evaluated from a measurement of irradiance and range.

Recalling that  $\sigma = \alpha + \gamma$  now  $\gamma$  may be calculated by subtracting off the value of  $\alpha$  in the experimental run. For an observation wavelength of less than one micrometer the value of  $\alpha$  is essentially equal to zero. However, for wavelengths greater than one micrometer molecular absorption begins to be appreciable.

Over the wavelengths of interest, molecular absorption is quite well known. This information is available in the form of the McClatchey code [Ref. 2]. This is a computer program used to calculate molecular absorption in the atmosphere. The data for this program is an exhaustive collection of over 100,000 line tabulations, containing frequency, intensity, half width and other pertinent information. To obtain  $\alpha$  one must specify wavelength, pressure, temperature, and molecular abundance of the species responsible for absorption:  $\text{CO}_2$ ,  $\text{N}_2\text{O}$ ,  $\text{CO}$ ,  $\text{CH}_4$ ,  $\text{O}_2$ ,  $\text{O}_3$ , and  $\text{H}_2\text{O}$ . The program will yield transmittance over a given path length  $L$ . From this transmittance  $\alpha$  can be calculated thus allowing the calculation of  $\gamma$ .

## 2. Scintillation Effects

In an experiment of this nature one must consider the amplitude modulating effects of scintillation, arising

from the turbulent nature of the atmosphere. As summarized by Strohbehn [Ref. 3], the field which exists at a receiver, in a line of sight problem, is the result of the multiplicative effects of the turbulent atmosphere. That is, the atmosphere may be characterized in the following manner.

Consider the atmosphere to be composed of a large number of turbulent modulating slabs oriented perpendicular to the direction of propagation. After passing through the first modulating slab the original field  $A_0$  is modified by a random modulating term  $M_1(t)$ . This results in a new field  $A_1 = M_1(t)A_0$ . This new field  $A_1$  passes through the next modulating slab and is appropriately altered,  $A_2 = M_2(t)A_1 = M_2(t)M_1(t)A_0$ . This can be extended until the receiver is reached.

$$A_r(t) = M_n(t) \cdot M_{n-1}(t) \cdots M_2(t) \cdot M_1(t) \quad (11)$$

Strohbehn states that if the width of the turbulent slab is several times larger than  $L_0$ , the outer scale of the turbulence, then  $M_1(t)$  is essentially independent of  $M_j(t)$ . Taking the natural logarithm of Eq. (11)

$$X_r(t) = \text{Ln} [A_r(t)] = \text{Ln} A_0 + \sum_{i=1}^n \text{Ln} M_i(t) \quad (12)$$

By allowing  $n$  to tend to infinity and the application of the Central Limit Theorem of probability, we see that the statistics of the log-amplitude are Gaussian.



## II. DESIGN OF EXPERIMENT

### A. GENERAL

The overall experiment will consist of an airborne platform towed over a marine environment, a shipboard equipment mount consisting of a ranging apparatus, a tracking system, and a diagnostic package. The Research Vessel ACANIA of the Naval Postgraduate School will be used as the base of the slant range (Fig. 2). The R/V ACANIA will be used to position the slant range at the mouth of Monterey Bay to obtain an environment closely resembling the open ocean (Fig. 3).

Actual experimental determination of  $\sigma$  will be as follows. A light pulse will be emitted from the ranging apparatus. This pulse, upon arrival at the airborne platform, will be reflected for ranging and will also trigger the flash source. The reflected ranging pulse will be received at the ship and time of flight will be measured and range determined. The time delay from reception of the reflected ranging pulse and the discharge of the source will be measured prior to experimental runs and will be used to extract the signal from noise using Synchronous Detection. The ship's reception of the ranging pulse will appropriately trigger the synchronous detector to sample the irradiance at the detector due to the source.

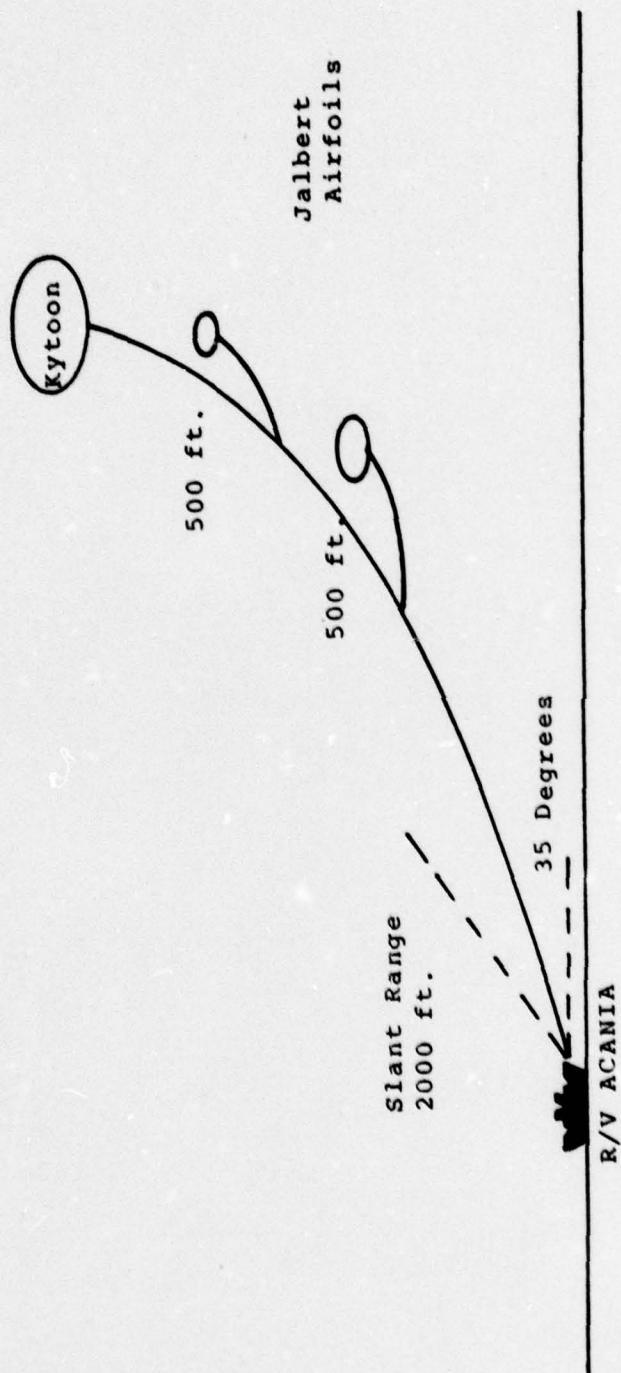

Figure 2. Proposed Slant Path Experiment



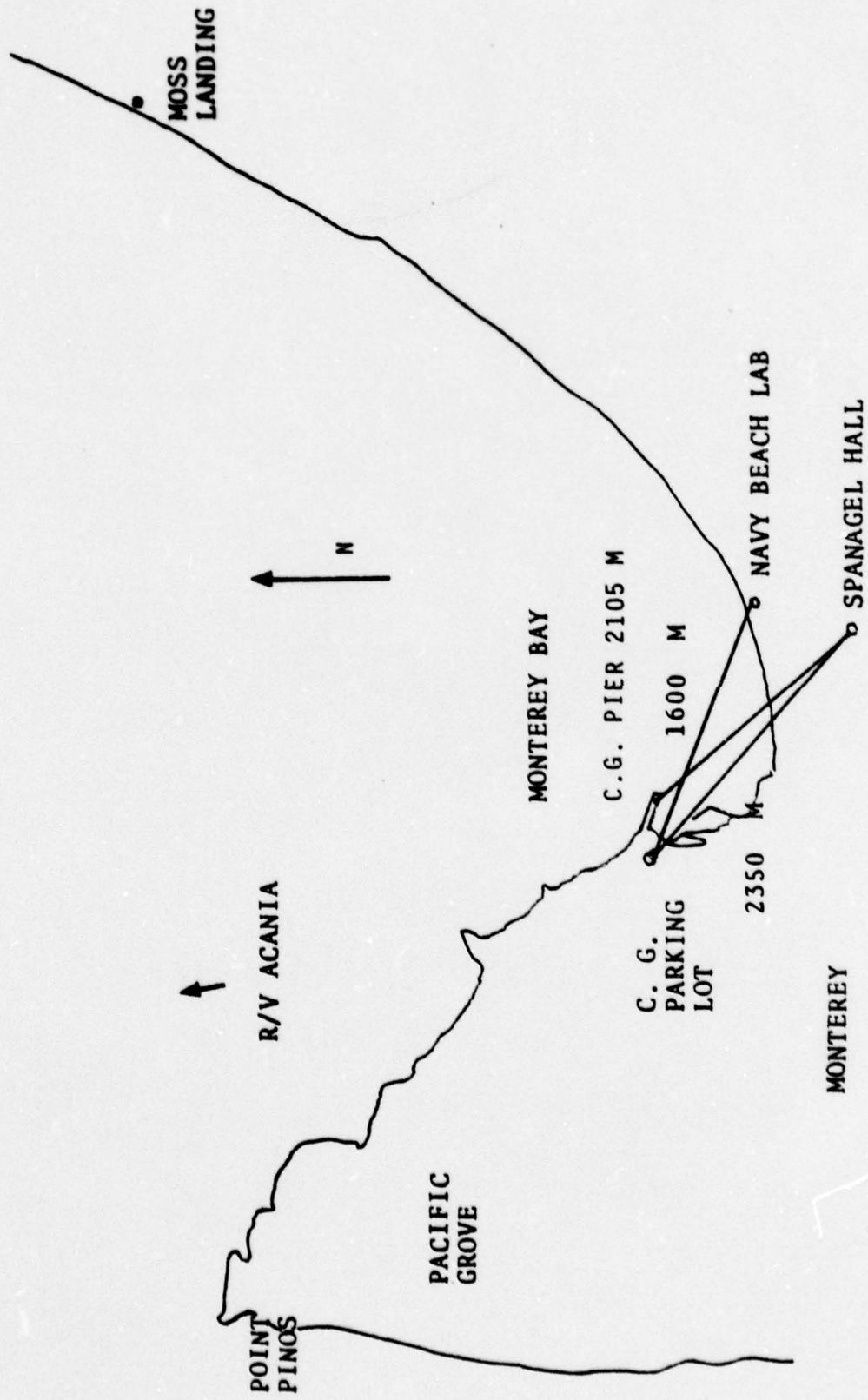

Figure 3. Monterey Bay Test Ranges.

These measurements will be collected at the rate of 1KHz. Allowing for the log-normal amplitude distribution of irradiance, samples will be collected until approximately 20,000 samples have been recorded at the mean of the distribution, a total time of approximately 25 seconds. The actual time necessary will depend upon the standard deviation of the log-normal distribution that exists at the time of observation. From the average values of irradiance and range, a value of the extinction coefficient will be calculated from Eq. (10). This process will be employed consecutively at the design wavelength bands centered about the following wavelengths: 0.4880  $\mu\text{m}$ , 0.6328  $\mu\text{m}$ , 1.06  $\mu\text{m}$ , 1.25  $\mu\text{m}$ , 1.60  $\mu\text{m}$ , 2.20  $\mu\text{m}$ , 3.80  $\mu\text{m}$ , and possibly 10.6  $\mu\text{m}$ .

## B. EQUIPMENT

### 1. Ranging Apparatus

The ranging system of this experiment will consist of three areas of instrumentation:

- a) Light pulse transmitter and receiver
- b) Airborne retroreflector
- c) Time of flight analyzer

The light pulse transmitter consists of a Ga As solid state injection laser (Laser Diode Laboratories Model LD-22) mounted with associated circuitry and optics, a Celestron 750 mm f/6 Schmidt-Cassegrainian telescope receiver with a G.E. Model 50-EHS silicon avalanche diode as a detector

(operated at a reverse bias of 2040 volts for a gain of one hundred), and a Hewlett-Packard Model HP-3310-A function generator. The entire transmitter and receiver package is shown (Fig. 4). The diode detector is configured in series with a selectable dropping resistor to control circuit RC.

Due to the use of retro-reflectors on the airborne platform it is necessary to locate the transmitting and receiving systems within the angular deviation of the retros employed. The use of colinear systems as shown in Fig. 4, will accomplish this. This system will transmit light to the retro-reflector where it will be laterally displaced and retro-reflected. This retro-reflection will be imperfect and some deviation will be experienced. For the retros used this deviation is less than 5 arc seconds. The combination of lateral displacement and imperfect reflection will allow the telescope to receive the majority of the reflected pulse.

Colinear mounting of the transmitting and receiving systems was provided by securing the laser transmitter to the central obscuration of the Celestron's Schmidt-Cassegrainian system. This mounting required a reduction in size of the laser pulsing circuit to fit within a cylindrical volume having  $1 \frac{3}{8}$  inch diameter and  $2 \frac{1}{2}$  inch length. Figure 5 shows the laser pulsing circuit adapted from Burman [Reference 4].

The adaptation of Burman's circuit consisted of two sections: 1) Design and construction of printed circuits to meet size requirements of this experiment (Fig. 6).



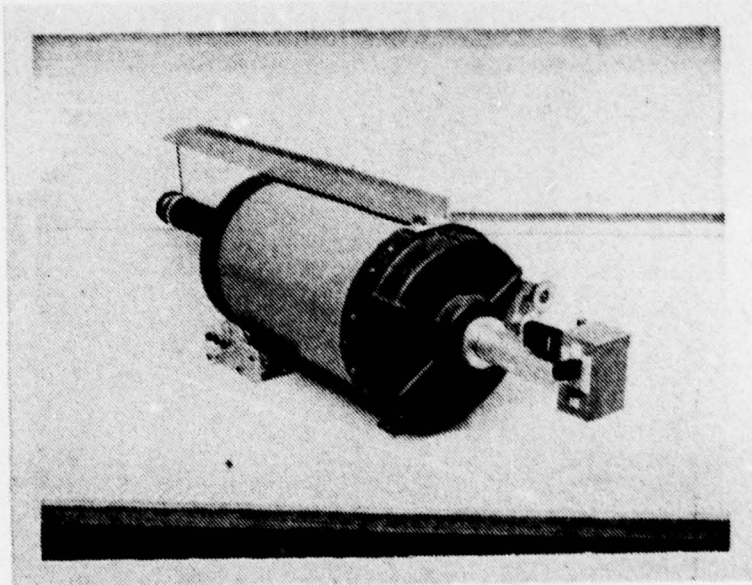
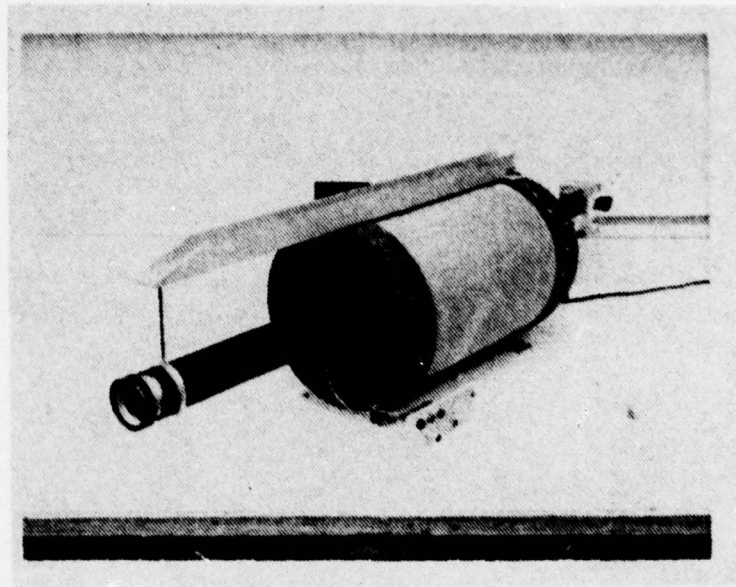

Figure 4. Ranging Equipment

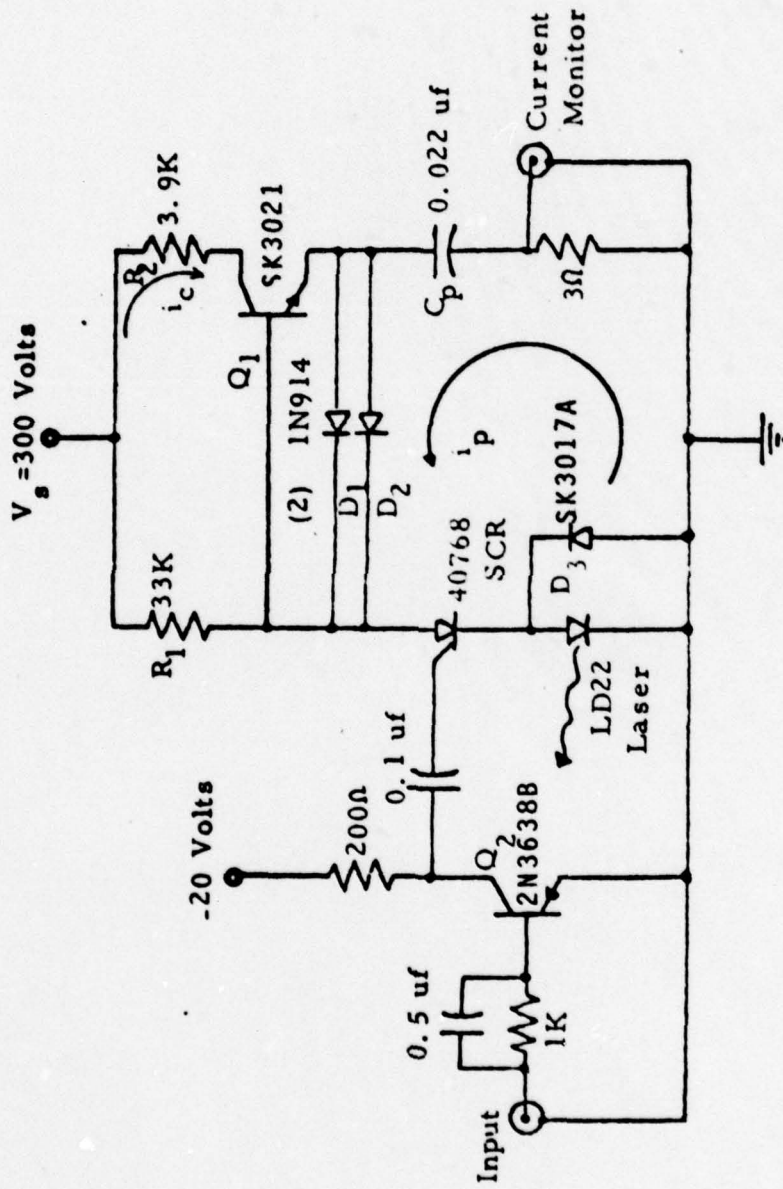
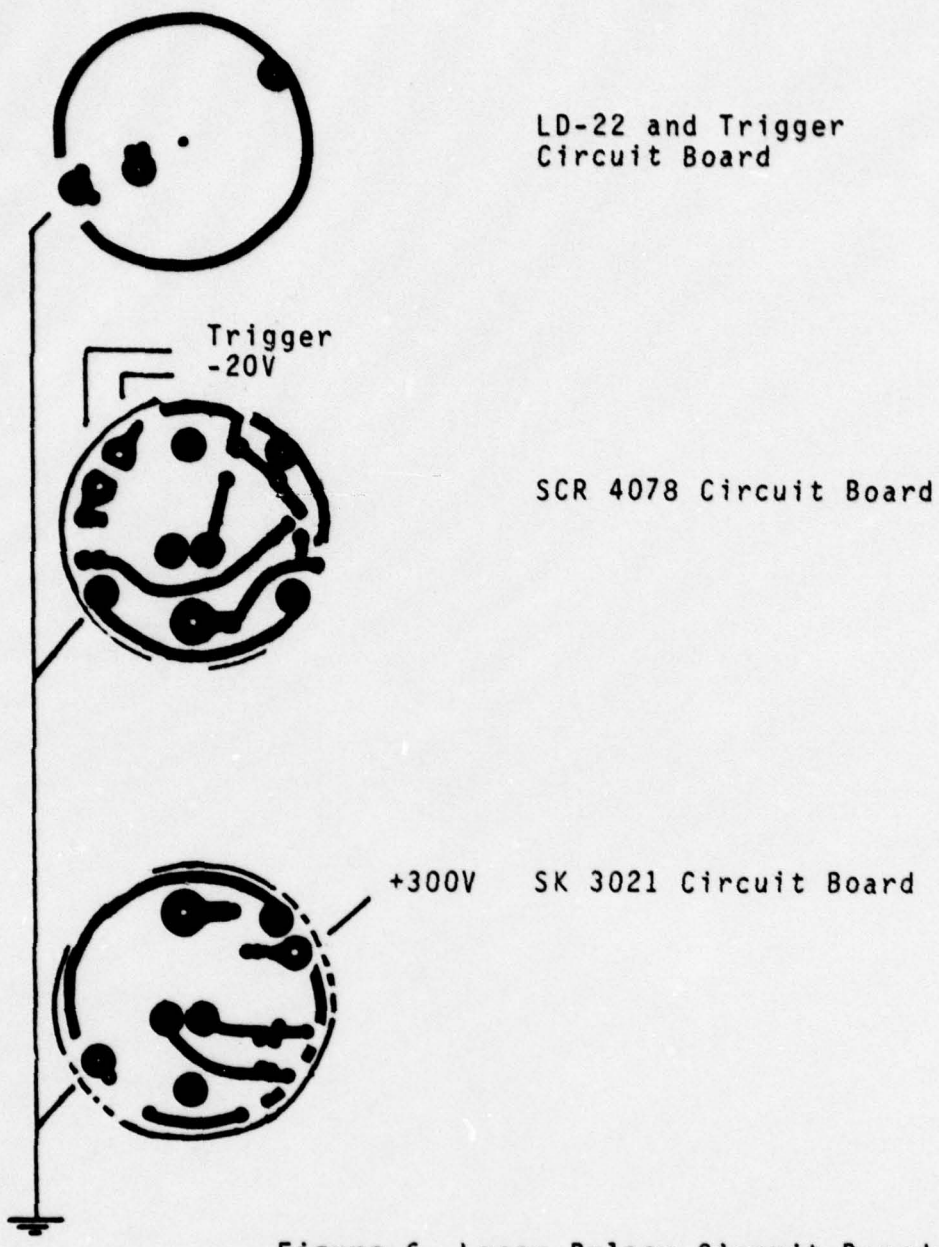

Figure 5. Transmitter Schematic





LD-22 and Trigger  
Circuit Board

SCR 4078 Circuit Board

+300V SK 3021 Circuit Board

Figure 6. Laser Pulser Circuit Boards

2) Replacement of certain components with comparable functioning ones to meet the size constraints composed by the printed circuits.

The pulsing circuit was constructed on three boards each of which contained one central circuit component 1) LD-22 laser, 2) SCR40768, and 3) SK 3021 transistor, as well as various other smaller components. These boards in final form were layered as close together as possible to reduce inductance. This allowed the production of a 280 nano second laser pulse. The entire laser and circuit package was mounted within the  $1 \frac{1}{2}$  inch diameter laser tube. The  $\frac{1}{8}$  inch clearance within the laser tube allowed the laser to be moved up-down and right-left across the face of the 200mm objective lens, by use of four adjustment screws, until the LD-22 was in the center of the objective. Another adjustment was added in the form of a collar, with three adjustable screws mounted at 120 degree angles from each other, attached to the board containing the LD-22 (Fig. 7). This adjustment insures that the angle at which the laser light was emitted was normal to the objective's thin lens refracting plane.

By correct manipulation of these adjustments the laser light emitted has a propagation ray which is coincident with the central axis of the Celestron receiving optics. By adjusting the focus of the objective one can vary the beam divergence from a minimum of 0.75 milliradians to the operating divergence of between 1.0 and 2.0 milliradians.

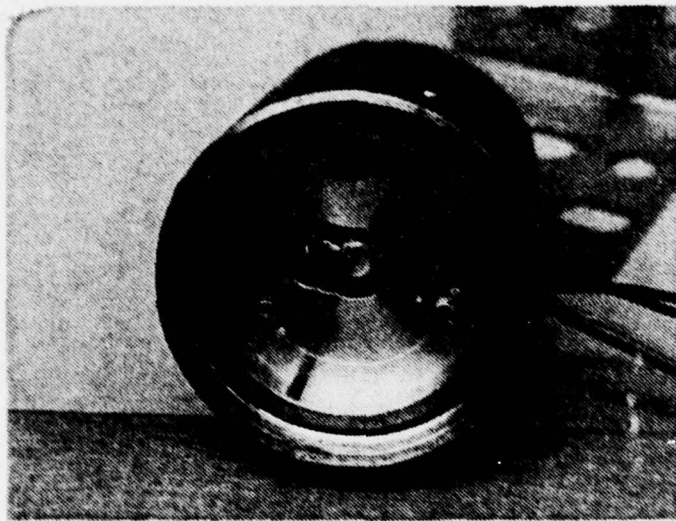

Figure 7. Laser and Adjustments



The actual emitting area of the GaAs laser has dimensions of 0.175mm and 0.035mm. The beam as emitted from the laser is rectangular in shape. When imaged shows areas of light and dark bands in the short dimension. The distance from the GaAs laser to the objective lens is 200mm. At this distance down the tube, the beam in the short dimension is approximately 50mm. The 52mm objective intercepts approximately 50 percent of the beam pattern. Under operating divergences the emitted laser beam's cross-section is approximately circular.

On the airborne platform a retroreflecting system will be employed to obtain the largest and most uniform signal to noise ratio at the Celestron receiver. The design package arrived at was the one considered optimum out of nineteen which were designed and analyzed. The criteria for determining the optimum configuration were uniformity of angular response, size and weight, and cost of building.

The type of individual retros which were selected were those having a circular aperture. The angular response of a singular circular aperture retro is shown in Fig. 8 [Ref. 5]. Although a single retro would minimize cost and weight requirements it would have a signal fluctuation of -3dB over the angular deviation expected ( $\pm 22^\circ$ ) and therefore an array of retros was decided upon to reduce this loss. Arrays containing from two (2) to twelve (12) retros of various sizes were investigated. The array which was judged the best for this experiment is shown in Fig. 9. Figure 10 shows the



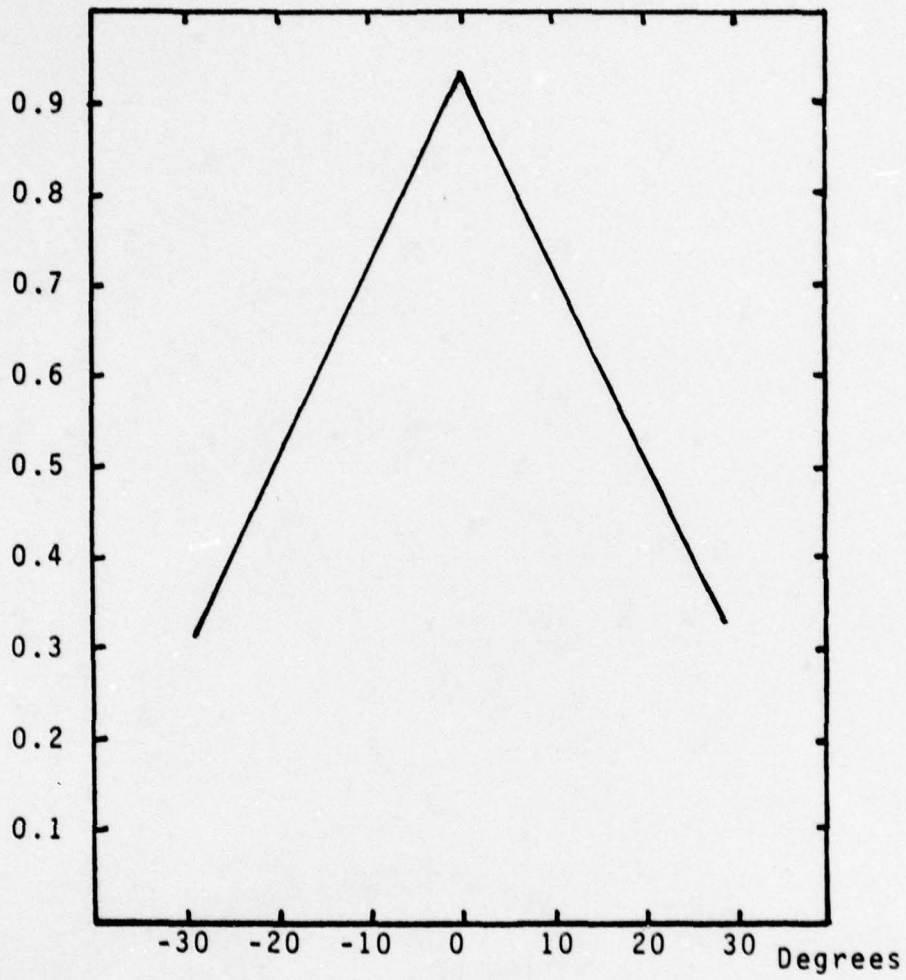

Figure 8. Radiant Power reflected from a circular aperture retro reflector vs angle of incidence

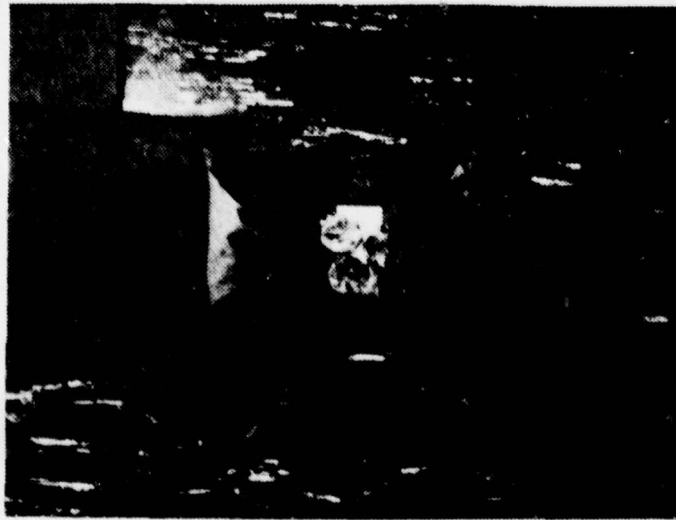

Figure 9. Three-Retro Array

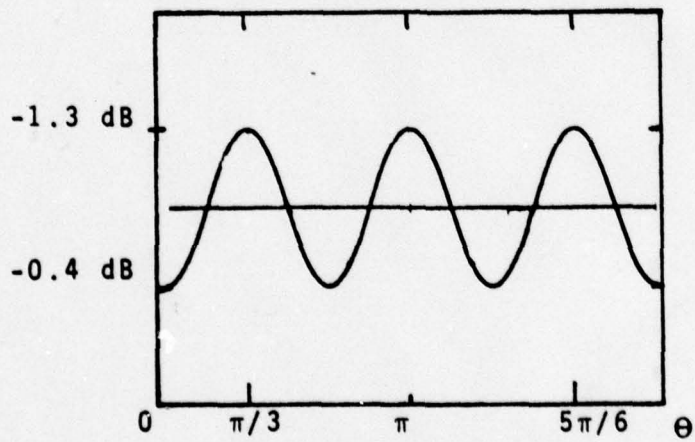
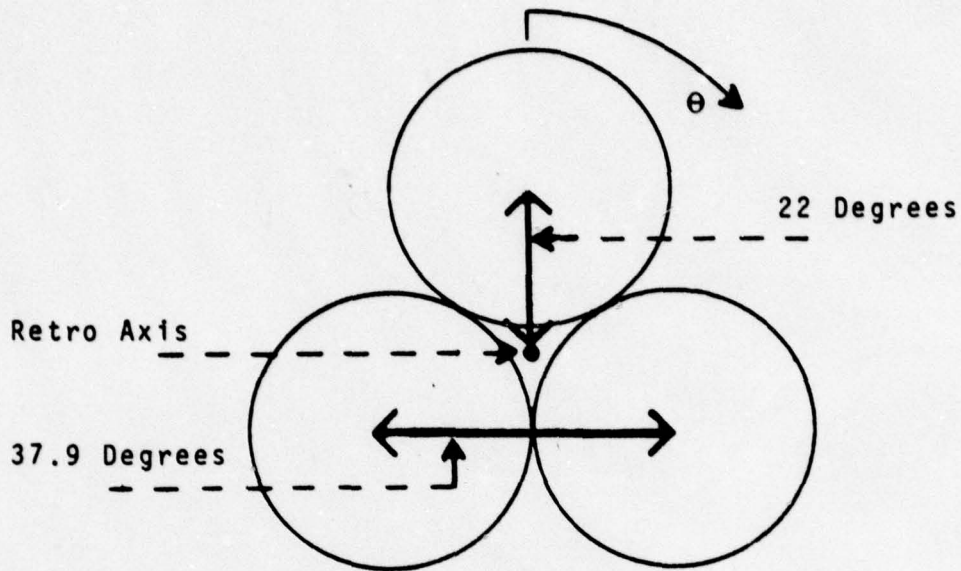

Figure 10. Airborne Retro design and response relative to return when slant range is on retro axis



worst response that may be expected from this array. This response is taken when the angle of incidence is  $22^\circ$  from the retro axis and is plotted as a function of around the array. The worst response expected is a variation of  $-1.3\text{dB}$  in the signal reflected. The accuracy of the retro reflection of the trihedral prism is less than 5 arc seconds deviation from perfect retro reflection.

The last section of the ranging system is the time of flight analyzer. This will consist of a Hewlett-Packard Model HP-1742-A 100Mhz delta-time oscilloscope. This scope is a dual trace, dual time base system capable of time duration measurements to an accuracy of 100 picoseconds. This scope was selected because the accuracy which is required in range measurements is easily handled by this scope's resolution. The 100 picosecond resolution on the ranging pulse's round trip flight converts to a range uncertainty of 0.049 feet. At a design range of 2000 feet for the experiment this value converts to a percent uncertainty of 0.0025%. In addition to the range accuracy provided by this scope, the LED readout which displays the time of flight in seconds provides for rapid evaluation of range.

The HP-1743-A can also introduce a time delay between the time channel A is triggered and the time that channel B becomes triggerable. At the time that channel B is triggered a square wave blanking pulse is produced at the scope's delayed gate. This will be used to trigger the demodulator

unit in the signal processing package. This triggering scheme is explained in Sec. II.B.6 of this work.

A range measurement is initiated by the square wave output of the HP-3310-A signal generator. This signal is used to trigger the laser pulser and also the channel A time base of the HP-1743-A. Some of the laser pulse, as it is emitted from the objective lens, is scattered back down the axis of the Celestron by means of a small corner cube prism. This scattered pulse, denoted  $t_0$ , serves as the zero time for range measurements. The reflected ranging pulse, denoted  $t_1$ , will return to the Celestron approximately 4  $\mu$ s after the  $t_0$  pulse has occurred. This 4  $\mu$ s is a result of the 2000 feet experiment design range. Both of these pulses are displayed on channel A of the HP-1743-A. The time between the occurrence of the  $t_0$  and the  $t_1$  pulses is accurately measured by the HP-1743-A. This is accomplished by adjusting two intensified marks on the trace of channel A until they bracket the  $t_0$  and  $t_1$  pulses. The corresponding time difference,  $\Delta t$ , is displayed on the LED readout, located on the scope face in the upper right hand corner. With this  $\Delta t$  the range may be determined by:

$$R = c\Delta t/2$$

where  $c$  is the speed of light.

## 2. Airborne Platform

The airborne support for the flash source, retro-reflector, and circuitry will be provided by the "Pie in the Sky, Inc." Model JK-20 kytoon which has the following characteristics:

- a) Length - 20 feet
- b) Volume - 400 cubic feet He.
- c) Payload - 14 pounds
- d) Increase in payload - 5-7 pounds for every 5-7 knots additional wind
- e) Construction - Mylar on fabric

This kytoon will fly at an angle of approximately 35° off the horizon. This may vary ±5° depending upon wind conditions.

Due to the weight of and wind resistance on the tether line, some sort of line support system is necessary to achieve the 35° operating angle. For this, two JALBERT AIRFOILS will be used [Ref. 6]. These airfoils will be placed at intervals approximately 500 feet below the kytoon providing lift support to the tether (Fig. 2).

## 3. Radiation Source

The flash source proposed for this experiment is one supplied by Mr. Vincent Rosati of the Combat Systems and Target Acquisition Laboratory, Fort Mammoth, New Jersey. The characteristics of this lamp are:

- a) Gas - Xenon
- b) Pressure - 450 torr



- c) Envelope - Quartz
- d) Arc length - one and one-half (1.5) inch
- e) Maximum energy - 50 Joules
- f) Operating energy - 5 Joules
- g) Pulse length - 100 microseconds
- h) Radiation - as a 10,000° K Black Body

This lamp should provide the necessary wavelengths to utilize all proposed wavelengths of observation with the exception of 10.6  $\mu\text{m}$ . The unavailability of the 10.6  $\mu\text{m}$  is due to the quartz envelope cutoff. Desired operating conditions may be accomplished by allowing a 10 microfarad capacitor, charged to 1KV, to discharge across the arc. The trigger to this flash source is to be provided by a PIN diode receiver located with the flash source on the airborne platform.

#### 4. Tracking System

This experiment requires the use of a gyrostabilized shipboard optical platform from which to track the airborne flash source. Such a platform has been developed by the Marine Boundary Optical Propagation research team of the Naval Postgraduate School. The system employs 2.5 inch refracting optics, a PIN SPOT/4D United Detector Technology quadrant photodiode, and associated electrical logic to produce up-down and right-left corrections to a 20 kilogram, 3600 rpm gyro rotor. For this experiment tracking will be accomplished at the wavelength of the GaAs ranging laser.

The reflected ranging pulse will not only be used for range determination but also for tracking, by the use of the appropriate wavelength selective filter. For a detailed analysis of this system see Ref. 8.

5. Frequency Bands of Observation and Detectors

The wavelength bands proposed for this experiment are as follows:

a. 0.4880 micrometer

This band extending from 0.4780  $\mu\text{m}$  to 0.4980  $\mu\text{m}$  will be isolated by using a 100  $\text{\AA}$  pass band filter located in front of a Si avalanche photodiode. This filter has a diameter of one (1) inch.

b. 0.6328 micrometer

Again using a 100  $\text{\AA}$  filter, one (1) inch in diameter, will create a band extending from 0.6228  $\mu\text{m}$  to 0.6428  $\mu\text{m}$ . This band will also be detected by a Si avalanche photo diode.

c. 1.06 micrometers

As in the above two frequency bands this band will be isolated with a one (1) inch 100  $\text{\AA}$  filter and will be detected by a Si avalanche photo diode.

d. 1.25 micrometers

This band may be isolated by using an OCLI (Optical Coating Laboratory, Inc.) Model WO1235-6, 0.20  $\mu\text{m}$  band pass filter. This one (1) inch diameter filter will isolate a band on 1.15  $\mu\text{m}$  to 1.35  $\mu\text{m}$ . To detect this frequency radiation a Germanium detector will be used.

e. 1.60 micrometers

In this wavelength band the atmosphere will be used as the short wavelength cutoff (Fig. 11). A gross isolation of the band will be accomplished with the use of a one (1) inch, 40 mil thick silicon filter and the spectral response of the Germanium detector. For fine isolation the McClatchy code will be used to remove the response due to the 1.2 light band which is included in the Si, Ge combination band pass. The final pass band will have a wavelength band from approximately 1.4  $\mu\text{m}$  to 1.71  $\mu\text{m}$ .

f. 2.20 micrometers

The 2.20  $\mu\text{m}$  band will be obtained by using an OCLI Model WO2332-7, 0.60  $\mu\text{m}$  band pass filter. The pass band of this filter extends from 2.03  $\mu\text{m}$  to 2.62  $\mu\text{m}$ . The atmosphere, depending upon path length cuts off at around 2.55  $\mu\text{m}$ . Because of atmospheric cutoff the pass band width will be reduced to approximately 0.50  $\mu\text{m}$ . The McClatchy code will be used to properly account for this long wavelength cutoff. This band will be detected by an InSb detector.

g. 3.80 micrometers

The 3.80  $\mu\text{m}$  band will be isolated by using an OCLI, WO3830-9 bandpass filter having a diameter of one (1) inch and a pass band width of 0.4  $\mu\text{m}$ . This band will be detected by an InSb detector. Source range will extend due to quartz envelope to about 4.5  $\mu\text{m}$ .



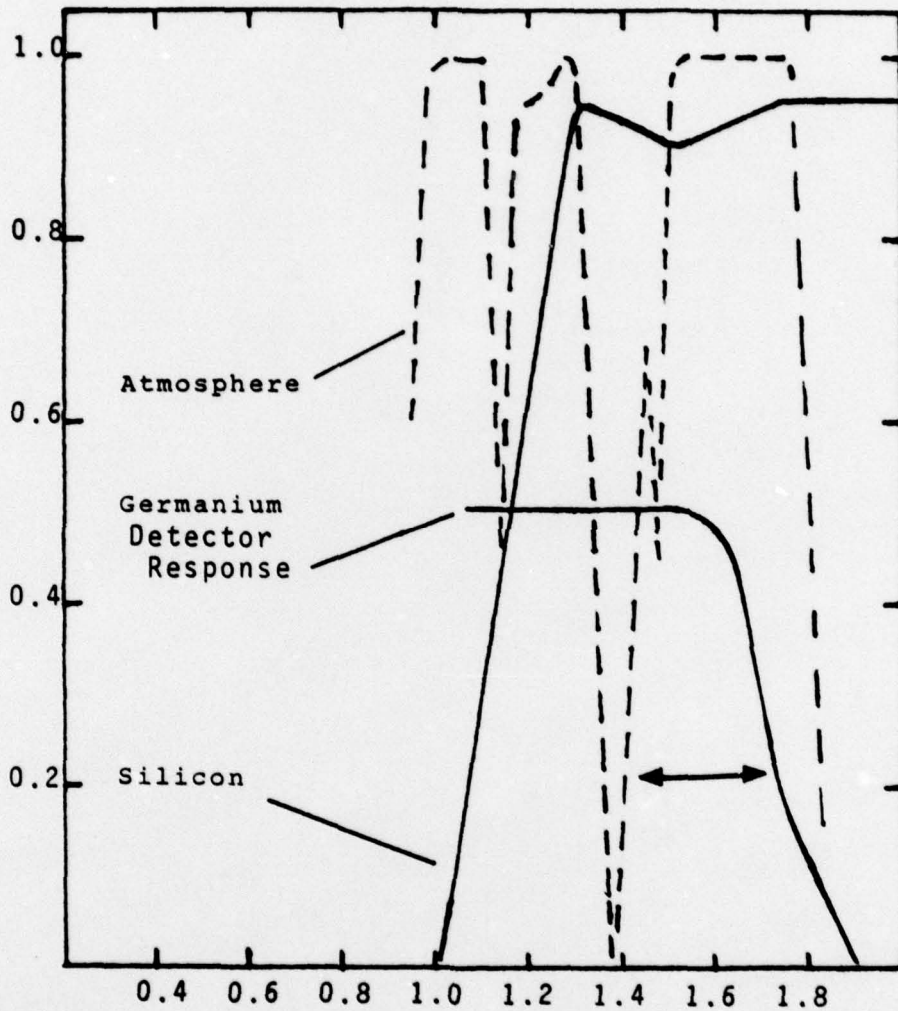

Figure 11. Transmission vs Wavelength (micrometers)

h. 10.6 micrometers

If a suitable flash source can be found, a 3.0  $\mu\text{m}$  pass band, around 10.6  $\mu\text{m}$  may be obtained by using an OCLI, W-10666-9 one-half (0.5) inch, wide band Germanium filter. This band would be detected by an HgCdTe detector.

6. Signal Processing

Figure 12 shows a block diagram of the signal processing scheme of this experiment. The heart of this system is the demodulator unit whose functions are: 1) Synchronously detect the output of the PAR 113 pre amp when a light signal due to the flash source and background is present; 2) Synchronously detect the output of the PAR 113 pre amp when only background is present; 3) Through the use of a differential instrumentation amplifier provide a voltage proportional to signal plus background minus background; and 4) Provide a trigger for the A/D converter to obtain a digital output for each arriving optical pulse.

To enable the demodulator to synchronously detect the arriving light pulses and background radiation an appropriate time reference is needed. This is supplied by the GE avalanche detector when the  $t_1$  laser ranging pulse is detected.

The HP-1743-A is equipped with a second delayed time base operable on channel B. By adjusting the trigger holdoff control, any desired delay may be introduced between the time channel A is triggered and the time that channel B

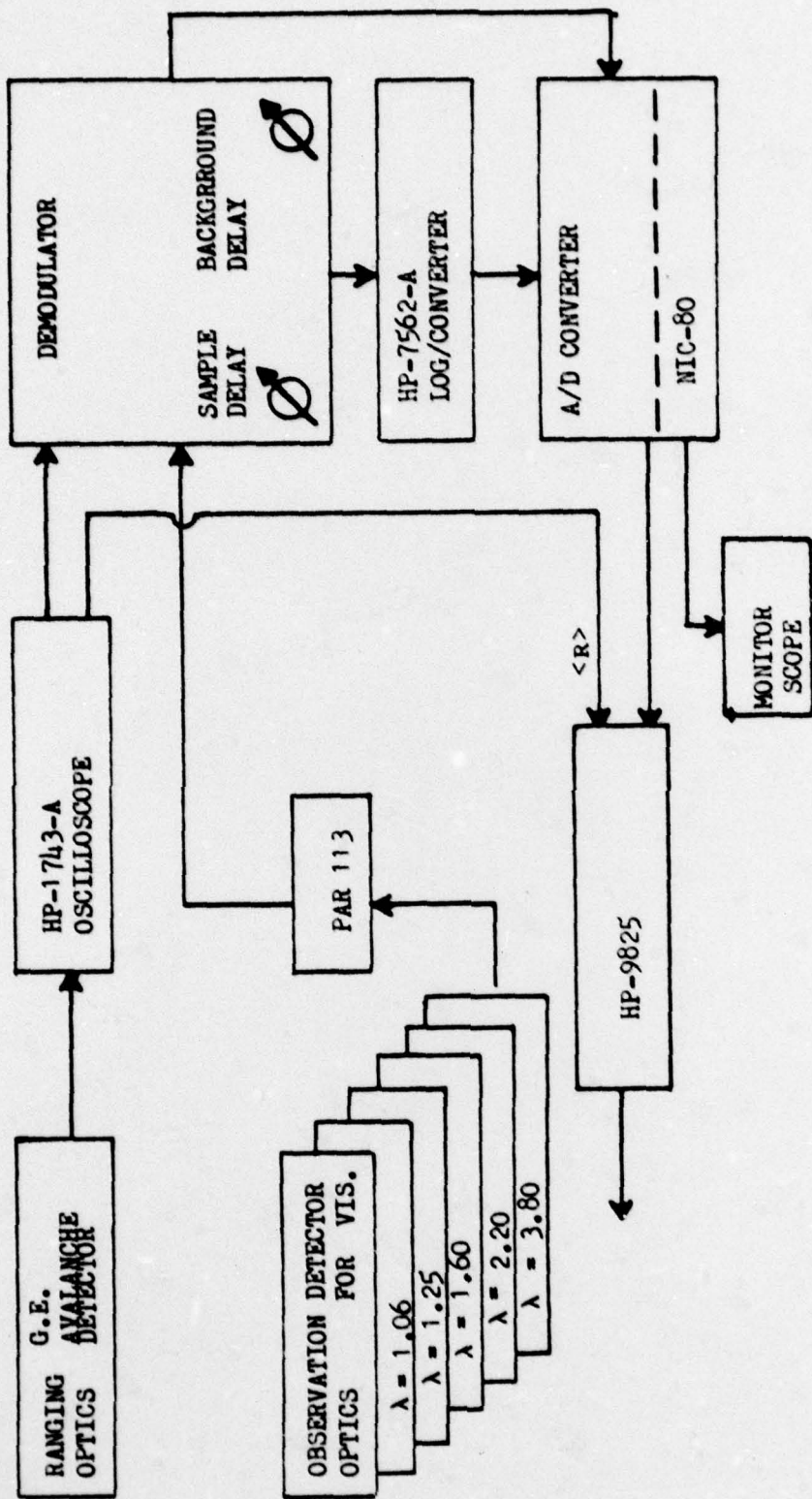

Figure 12. Signal Processing Scheme Flowchart



becomes triggerable. One should introduce a delay in excess of the time that is required for the  $t_0$  pulse to arrive after the laser circuit has been triggered and less than the time required for the  $t_1$  pulse to be reflected and return. This allows channel B to be triggered by the arrival of pulse  $t_1$ . When the second time base is triggered an output square wave is generated at the scope's delayed gate. This gate blanking pulse is used to trigger the demodulator.

The time delay between the arrival of the GaAs trigger pulse and the time the flash source discharge reaches a maximum output is a known quantity measured prior to any experimental trials. A time delay of this value is set in the sample delay of the demodulator. This assures the experimenter of sampling the flash signal at the same relative time, for successive pulses.

The sampling portion of the demodulator is constructed around a sample and hold circuit which like a capacitor, charges to the maximum value of the input signal and holds it. Once the maximum is obtained and the sample delay has elapsed then the attained maximum voltage is sampled and stored. The circuit is then dumped and records background level. This level is sampled when the background delay has elapsed. This value is set to insure that the sample and hold circuit has dumped, the flash source has extinguished and only background is being measured. Then

the sample of background is subtracted from the sample of signal thus producing the output of the demodulator, a voltage proportional to signal only. For more detailed discussion of the demodulator see Ref. 9.

After the demodulator, the logarithm of the signal is taken by the Hewlett-Packard Model HP-7562-A log voltage/converter. This process is to take advantage of the Gaussian statistics of the log-amplitude probability distribution resulting from scintillation. From the HP-7562-A the analog signal is digitized. This is accomplished in the A/D converter portion of the NIC-80 (Nicolet Instrument Corporation) computer. This A/D conversion is triggered by the demodulator. Within the NIC-80 after the A/D conversion the signal amplitude is recorded in the many bins of memory. As the process of bin accumulation is proceeding the progress is displayed on the monitor scope. To insure good statistics at least 20,000 bits must be accumulated in the bin having an amplitude value corresponding to the mean of the statistics. This process takes approximately 25 seconds. After 25 seconds data collection is terminated and the information stored in the bins of the NIC-80 is transferred to the Hewlett-Packard Model HP-9825 calculator, which computes the "best fit" Gaussian curve to the acquired data points. The voltage corresponding to the mean of the best fit Gaussian, as modified by the variance is taken to be proportional to the average irradiance at the receiver during the 25 seconds of data collection. The average voltage is computed from:

$$\langle V \rangle = \text{Exp} \left[ \langle \text{Ln} V \rangle + \frac{\sigma^2}{2} \right] \quad (13)$$

For indepth analysis of this equation see Ref. 10. Since  $\langle V \rangle$  is proportional to the average irradiance at the receiver  $\langle H \rangle$  can be calculated by:

$$\langle H \rangle = \langle V \rangle / G \quad (14)$$

where  $G$  is the overall gain of the electrical processing equipment. The value of  $\langle H \rangle$  and  $\langle R \rangle$ , obtained during the 25 seconds of observation, will be used to calculate the extinction coefficient by Eq. (10).



### III. CONCLUSIONS

The status of the experiment at the completion of the author's work at the Naval Postgraduate School was:

A. The range measurement device as represented in Fig. 4, was constructed and tested. The transmitting and receiving system was placed on the roof of Spanagle Hall, Naval Postgraduate School, and ranges were taken to the R/V Acania moored at the Coast Guard pier (Fig. 3). A range of 2,105 meters was observed. On the basis of this experiment the range measurement system is not ready for mounting on the gyro-platform tracking system.

B. Flights using the Jalbert Airfoils to support the tether line of the kytoon were performed aboard R/V Acania and were found to be satisfactory.

C. Flash lamps as specified herein were procured but due to late arrival have not been tested at the Naval Postgraduate School.

### BIBLIOGRAPHY

1. Hudson, R.E., Infrared System Engineering, Wiley, 1969.
2. McClatchey, R.A., Atmospheric Absorption Line Parameters Computer Code Tape, May 31, 1977.
3. Strohben, J.W., "Line-of-Light Wave Propagation Through the Turbulent Atmosphere," Proceedings of the IEEE, p. 1301-1317, Aug. 1968.
4. Burman, G.A., An Optical Object Detection System For Sensing Obstructions to Low Speed Vehicles, M.S. Thesis, U.S. Naval Postgraduate School, Monterey, 1972.
5. Electro-Optics Handbook, RCA, Harrison, N.J., 1974.
6. Jalbert Aerology Laboratory, Inc., "Advertising paper Jalbert Airfoil," Boca Raton, Florida.
7. Rosati, V., 23 May 1978 telephone conversation, Fort Mammoth, N.H., (801) 544-5384.
8. Williams, R.L., M.S. Thesis, U.S. Naval Postgraduate School, Monterey, 1978 (unpublished).
9. Naval Postgraduate School Report NPS61-78-003, Optical Resolution in the Turbulent Atmosphere of the Marine Boundary Layer, by E.C. Crittenden Jr., A.W. Cooper, E.A. Milne, G.W. Rodeback, R.L. Armstead, S.H. Kalmbach, D. Laud and B. Katz, February 1978.
10. Parish, P.W., Shipboard Measurements of 0.6328 Micrometer Laser Beam Extinction in the Marine Boundary Layer, M.S. Thesis, U.S. Naval Postgraduate School, Monterey, 1976.

INITIAL DISTRIBUTION LIST

	No. Copies
1. Defense Documentation Center Cameron Station Alexandria, Virginia 22314	2
2. Library, Code 0142 Naval Postgraduate School Monterey, California 93940	2
3. Professor K.E. Woehler, Chairman, Code 61Wh Department of Physics and Chemistry Naval Postgraduate School Monterey, California 93940	2
4. Professor D.E. Kirk, Code 62Ki Chairman Department of Electrical Engineering Naval Postgraduate School Monterey, California 93940	1
5. Professor E.C. Crittenden Jr., Code 61Ct Department of Physics and Chemistry Naval Postgraduate School Monterey, California 93940	3
6. Commandant (G-PTE) U.S. Coast Guard Washington, D.C. 20590	2
7. LT Daniel Glen Henderson, USCG Commandant (EOE) U.S. Coast Guard Washington, D.C. 02590	2