

ADA 059 747

LIBRARY
TECHNICAL REPORT SECTION
NAVAL POSTGRADUATE SCHOOL
MONTEREY, CALIFORNIA 92040

Translation T-349

NAVAL SHIP RESEARCH AND DEVELOPMENT CENTER

Bethesda, Md. 20034



SUBMARINE CONSTRUCTION

(UNTERSEEBOOTSBAU)

by

Professor Dipl.-Ing. Ulrich Gabler

Wehr und Wissen Verlagsgesellschaft Publication 6426
Darmstadt, West Germany

APPROVED FOR PUBLIC RELEASE: DISTRIBUTION UNLIMITED

August 1972

Translation T-349

SUBMARINE CONSTRUCTION (UNTERSEEBOOTSBAU)

130

The Naval Ship Research and Development Center is a U. S. Navy center for laboratory effort directed at achieving improved sea and air vehicles. It was formed in March 1967 by merging the David Taylor Model Basin at Carderock, Maryland with the Marine Engineering Laboratory at Annapolis, Maryland.

Naval Ship Research and Development Center
Bethesda, Md. 20034

MAJOR NSRDC ORGANIZATIONAL COMPONENTS

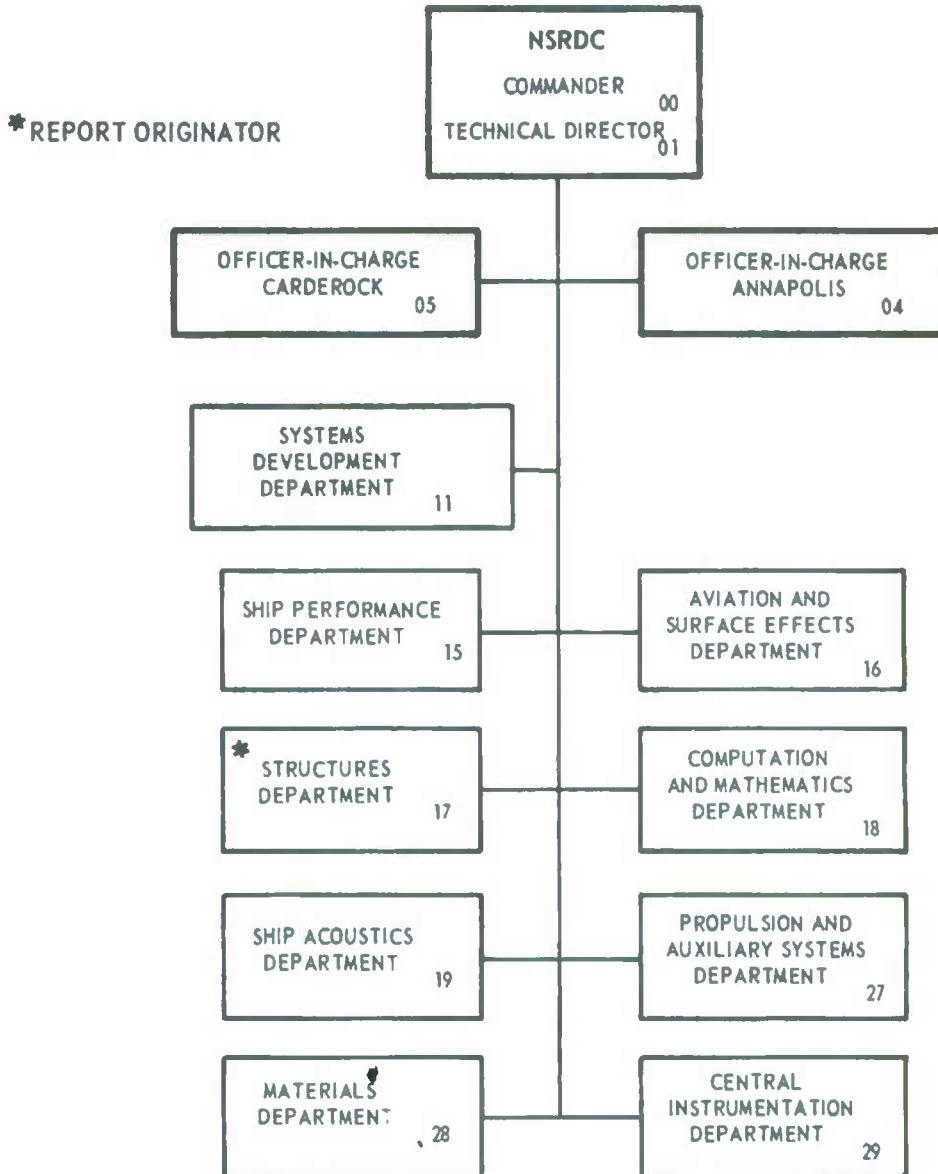

DEPARTMENT OF THE NAVY
NAVAL SHIP RESEARCH AND DEVELOPMENT CENTER

BETHESDA, MD. 20034

SUBMARINE CONSTRUCTION

(UNTERSEEBOOTSBAU)

by

Professor Dipl-Ing. Ulrich Gabler



Wehr und Wissen Verlagsgesellschaft Publication 6426

APPROVED FOR PUBLIC RELEASE: DISTRIBUTION UNLIMITED

August 1972

Translation T-349

FOREWARD

This book deals comprehensively with the nature of submarines, more specifically, with their planning, design, and construction. The associated equipment and operation of submarines are treated only when necessary to understand special construction details.

The book discusses the present status of the techniques of submarine construction, although there have been no new developments in this field in Germany for decades. Its purpose is to serve as a handbook for design and construction engineers and shipbuilders and to introduce naval officers to the field of submarine engineering.

I would like to thank those firms which kindly provided the photographs. The sketches were made by my colleagues at Ingenieurkontor Luebeck. I also would like to thank Mr. H. G. Hahn for editing the text and Mr. C. Aschmoneit, Federal Building Director, for his review.

Luebeck, January 1964

U. Gabler

TABLE OF CONTENTS

	Page
CHAPTER I: SUBMARINE DEVELOPMENT UP TO THE END OF WORLD WAR I	1
CHAPTER II: DEVELOPMENTS SINCE THE END OF WORLD WAR I	4
CHAPTER III: CHARACTERISTICS OF SUBMARINES	10
CHAPTER IV: GENERAL DESCRIPTION OF A SUBMARINE	13
CHAPTER V: DIVING AND STABILITY	18
DIVING	18
ARRANGEMENT OF THE TANKS WITH RESPECT TO REQUIREMENTS FOR SUBMERGED CRUISING	21
Ballast Tanks	21
Regulating Cells	23
Trim Tanks	25
Negative Tanks	26
STABILITY	26
CHAPTER VI: DYNAMICS	30
DESIGN OF THE SUBMARINE VERSUS THE SUBMERSIBLE ..	30
SUBMERGED DRAG	35
PROPULSION	38
DEPTH CONTROL	39
MODEL BASIN EXPERIMENTS AND SUBMERGED TRIALS	42
CHAPTER VII: STEEL STRUCTURES	44
LOADING DUE TO WATER PRESSURE	44
SHOCK LOADS	44
OTHER LOADS	45
STRENGTH OF THE PRESSURE HULL	45
PRESSURE-RESISTANT CONNING TOWER	50
STRENGTH OF OTHER STRUCTURAL MEMBERS	52
CHAPTER VIII: ARMAMENT	53
TORPEDO ARMAMENT	53
Torpedo Tubes	53
Torpedo Discharge Principle	55
Torpedo Launching Principle	56

	Page
Torpedo Tanks (WRT)	58
Torpedo Loading System and Torpedo Storage	59
Arrangement of the Torpedo Armament	59
WEAPON CONTROL SYSTEMS	61
MINE ARMAMENT	61
GUNNERY	62
CHAPTER IX: METHODS FOR DETECTION, WARNING, AND DECEPTION	63
DETECTION SYSTEMS	63
Radar Systems	63
Sonar Systems	63
Sound Detection	64
WARNING SYSTEMS	66
Radar Warning System	66
Sonar Warning System	66
DECEPTION METHODS	66
CHAPTER X: PROPULSION PLANTS	69
PROPULSION PLANTS THAT USE LEAD BATTERIES, ELECTRIC DRIVE MOTORS, AND DIESEL ENGINES	69
Lead Battery	72
Electric Engine	76
Diesel Engines	79
Air Intake and Gas Exhaust Systems for the Diesel Engines	79
Diesel Fuel and Pressurized Water System	82
Snorkel Systems	84
Cruising Range Calculations	88
PROPULSION DEVICES BASED ON OTHER PRINCIPLES	90
The Walter Principle	90
Closed-Cycle Principle	93
Nuclear Propulsion Plant	94
CHAPTER XI: SHIP HANDLING EQUIPMENT	95
CONTROL SURFACES	95
BALLAST TANK EQUIPMENT	96

	Page
PRESSURE HULL CLOSURES	99
EQUIPMENT FOR DRAINING AND FLOODING	101
EQUIPMENT FOR TRIMMING	103
COMPRESSED AIR SYSTEM	105
HYDRAULIC OIL SYSTEM	108
ELECTRICAL NETWORK	108
ANCHOR EQUIPMENT	110
EQUIPMENT FOR TOWING AND MOORING	111
CHAPTER XII: NAVIGATION AND COMMUNICATION INSTALLATIONS	112
COMPASS SYTEMS	112
INDICATOR SYSTEMS FOR SUBMERGED CRUISING	113
PERISCOPE	115
SOUNDING DEVICES	120
SPEED MEASURING SYSTEMS	121
ALARM SYSTEMS WITHIN THE BOAT	122
RADIO DIRECTION FINDER (RDF)	122
TELECOMMUNICATION SYSTEMS	123
UNDERWATER TELEGRAPHY	123
CHAPTER XIII: CREW HABITABILITY	125
ACCOMMODATIONS	125
PROVISIONS	125
FRESH WATER	125
WASH WATER	126
GALLEY FACILITIES	126
SANITARY FACILITIES	127
VENTILATION SYSTEM	127
AIR PURIFICATION SYSTEM	130
Carbon Dioxide Absorbent System	131
Oxygen Replenishment System	132
HEATING SYSTEM	132
CHAPTER XIV: SAFETY AND RESCUE FACILITIES	133
SAFETY FACILITIES	133
RESCUE FACILITIES	134

	Page
CHAPTER XV: DESIGN	139
SPECIFICATIONS	139
DEVELOPMENT OF A DESIGN TYPE	140
DEVELOPMENT OF CONSTRUCTION DETAILS	146
CHAPTER XVI: CONSTRUCTION AND COMMISSIONING	153
APPENDIX	159
BIBLIOGRAPHY	168

LIST OF FIGURES

	Page
Figure 1 - Interior of a Diesel-Electric Propulsion Submarine	14
Figure 2 - Displacement Relationships for Submarines	19
Figure 3 - Arrangement of the Principal Tanks in a Double-Hull Submarine	22
Figure 4 - Stability Relationships	27
Figure 5 - Lines of a Submarine	31
Figure 6 - Lines of a Submersible	31
Figure 7 - Twin-Screw Stern Configurations	34
Figure 8 - Single-Screw Stern Configurations	34
Figure 9 - Lines of the German Type 26 (1944)	36
Figure 10 - Upper Deck and Superstructure of Type Based on U2 (1962)	37
Figure 11 - Plane Positions	40
Figure 12 - Plane Positions during a Dive	42
Figure 13 - Yielding of Shell between Frames	47
Figure 14 - Shell Buckling between Frames	47
Figure 15 - Complete Collapse of a Pressure Hull	47
Figure 16 - Pressure Hull End Closure Bulkheads of Cast Steel	49
Figure 17 - Pressure Hull End Closure Bulkhead of Flat Welded Design	49
Figure 18 - Elliptical Conning Tower (German Boats, 1935-45)	50
Figure 19 - Conning Tower of Two Cylindrical Shells	51

	Page
Figure 20 - Conning Tower Constructed as a Horizontal Cylinder	51
Figure 21 - Torpedo Tube, Forward View	54
Figure 22 - Torpedo Tube, Aft View	54
Figure 23 - Piston-Type Torpedo Tube	57
Figure 24 - Torpedo Loading System	60
Figure 25 - Transducer of a Sonar System	65
Figure 26 - Supporting Structure for a Sonar Dome	65
Figure 27 - Balcony Configuration of Receivers	65
Figure 28 - Ejection Lock for "Bold"	68
Figure 29 - A Twin-Shaft Installation with Direct Diesel Propulsion	71
Figure 30 - A Single-Shaft System with Direct Diesel Drive and Separate Low-Noise Electric Drive	71
Figure 31 - A Twin-Shaft System with Direct Diesel Drive, Main Electric Drives with Separate Reduction Gears, and Separate Low-Noise Propulsion System	71
Figure 32 - A Single-Shaft System with Direct Electric Drive and Separate Diesel Generators	73
Figure 33 - Structure of a Grid-Plate Cell	73
Figure 34 - Capacity Characteristics of a Lead-Acid Cell Battery	73
Figure 35 - Voltage Curves of a Lead Battery for Different Discharge Times	74
Figure 36 - Charging Characteristics of a Lead Battery	74
Figure 37 - Battery Installation	75
Figure 38 - Submarine Electric Engine, Open	78
Figure 39 - Submarine Electric Engine with Air Coolers, Closed	78
Figure 40 - Main Switchboard for a 300-Horsepower Electric Engine	80
Figure 41 - Diesel Engine Air Intake System	80
Figure 42 - Diesel Engine Exhaust System	81
Figure 43 - Inboard Exhaust Flap	81
Figure 44 - Fuel and Pressurized Water System	83
Figure 45 - Snorkel System Design Used in German Type 21, 1944	85

	Page
Figure 46 - Arrangement for Actuating Snorkel Head Valve by Compressed Air	86
Figure 47 - Electrical Controls and Hydraulically Operated Snorkel Head Valve	86
Figure 48 - The Walter Submarine Propulsion System	91
Figure 49 - The Experimental Walter Boat V-80 during Surface Cruising, 1939	92
Figure 50 - Propulsion System used in the German Type 26	93
Figure 51 - Closed-Cycle System for Submarines	94
Figure 52 - Folding and Retractable Diving Planes	95
Figure 53 - Depth Control Stations in the Control Room	97
Figure 54 - Combination Rudder and Diving Plane Controls	98
Figure 55 - Ballast Tank Equipment	98
Figure 56 - Hatch Cover	100
Figure 57 - Handwheels and Cranks for Outboard Closures	102
Figure 58 - The Drain and Flood System	102
Figure 59 - Reciprocating Drain Pump	104
Figure 60 - Trim Equipment	104
Figure 61 - Four-Stage High-Pressure Air Compressor with Electric Drive	107
Figure 62 - Compressed Air System	107
Figure 63 - Central Hydraulic Plant	109
Figure 64 - Anchor Equipment	110
Figure 65 - Bourdon Gage Depth Indicators	114
Figure 66 - Papenberg Depth Gage	114
Figure 67 - Trim Indicator	114
Figure 68 - Papenberg Depth Gage and Trim Indicator	114
Figure 69 - Attack Periscope	116
Figure 70 - Periscope Hoisting Systems	117
Figure 71 - Pressure Hull Penetration for Periscope	118
Figure 72 - External View of an Attack Periscope	119
Figure 73 - Standard Periscope	120
Figure 74 - Retractable Rod Antenna	124
Figure 75 - A Head System	127
Figure 76 - A Ventilating and Air Circulating System	128

	Page
Figure 77 - Ventilation Methods	129
Figure 78 - Hatch with Air Trap	135
Figure 79 - Aqualung	135
Figure 80 - Diving Bell for Submarine Crew Rescue	138
Figure 81 - Hull Cross Sections	141
Figure 82 - Superstructures of Submarines and Submersibles	144
Figure 83 - Displacement and Other Curves of Form	147
Figure 84 - Longitudinal Presentation of Sectional Area	149
Figure 85 - Midship Framing	149
Figure 86 - Assembly of a Pressure Hull on the Slipways	155
Figure 87 - Assembly of a Pressure Hull by Sections	155

LIST OF TABLES

	Page
Table 1 - Most Important Data on German Submarines, 1935-1945	8
Table 2 - Submarines, 1935-1939	160
Table 3 - Submersibles, 1944	163
Table 4 - Submersible with Walter Propulsion Systems, 1939-1945	165

CHAPTER I

SUBMARINE DEVELOPMENT UP TO THE END OF WORLD WAR I

The history of submarine construction goes well back into ancient times. Attempts at controlled submerged cruising were successful even before the machine age. However true underwater vehicles could not be built until the availability of machinery plants which were not dependent on a steady supply of outside air. The first submarines of this type were propelled by battery-powered electric motors. Their cruising range depended essentially on the capacity of the storage battery which was charged in port or by an escort ship. These submarines were combat ready only for brief operations, which were carried out mainly under water. The following were milestones:

1. In 1887, J. Peral, a Spaniard, built the first submarine provided with storage batteries.
2. In 1888, Zédé, a Frenchman, built a similar boat.
3. In 1902, FORELLE, the first successful vessel with this type of propulsion, was built in Germany at the Germania Shipyard and was sold to Russia in 1904.

The next stage of development was that of self-charging submarines; these were capable of charging batteries while operating on the surface and had a separate power plant for surface cruising. Different types of propulsion plants (e.g., steam engines or oil engines) were tried until, finally, the diesel engine proved to be the most useful type of engine for surface cruising. The performance capability of the diesel engines made it possible to use these submarines for a variety of purposes.

Right from the start, a structural distinction was made between double- and single-hull boats. The double-hull boat was more seaworthy for surface navigation than the single-hull. At the beginning of World War I, all the larger navies had a number of self-contained submarines, all of which carried torpedo armament. Milestones in this development were:

1. In 1899, the French NARVAL, the prototype of the double-hull submarine, was launched.

2. In 1900, several U. S. submarines of the HOLLAND class (single hull) were ordered.

3. In 1904, an order was placed for construction of the U-1 (double hull) at the Germania Shipyard in Kiel.

There were many different opinions regarding the possible uses for submarines.

World War I proved that the self-charging submarine was most effective when used alone on long-range operations. Long cruises were invariably made on the surface, and the submarine usually submerged only when the enemy was sighted during the day.

The submarine's main weapon, the torpedo, required that the attack be launched at close range. The submarine could use its torpedoes in a daytime attack while submerged or in a night attack while on the surface. The approach to the enemy went unnoticed by day when the submarine was submerged and using its periscope. A night approach on the surface took advantage of the low silhouette. Because of its ability to submerge, the submarine could penetrate sea areas controlled by the enemy, escape enemy attacks by diving, and attack any major target with its torpedoes.

The submarine was capable of carrying other types of weapons as well. As a mine layer, it could lay mines unnoticed in places that were inaccessible to surface vessels. Guns became very important in the warfare against merchant ships. Individual submarines were fitted with heavy, armored guns for engaging land-based targets. The submarine was sometimes used for reconnaissance in cooperation with units of a fleet. It became an extremely dangerous weapon in the hands of a weaker naval power.

The fact that at that time submerged submarines ran "deaf" and "blind" was a decisive factor in the way in which they were used. Visual range was limited to periscope depth. The range of optical observation was much greater on the surface, but, even when visibility was good, it could not compare with that of surface vessels because of the relatively low observation level. Because the chance of sighting an enemy was greater on the surface, the highest possible surface speed was the measure of a submarine's value. Conditions permitting, the submarine could take advantage of its surface speed during the daytime to take up a favorable position for launching a submerged attack. Underwater attack speeds were generally

slow because the periscope could not be used continuously. The night surface attack was the preferred method because it enabled a faster attack speed.

Submerged drag was greatly increased by the requirement for surface ←
cruising and by the armament mounted on the upper deck. However, since maximum submerged speed was considered of relatively little importance, the speed and endurance for submerged cruising continued to decrease. Basically it was sufficient if the submarine could stay submerged, all day if necessary, until it could surface at night to recharge its batteries.

Diving time was reduced significantly during World War I. Submarines with these type features will be referred to in what follows as submarines (tauchboots).

The double-hull construction was preferred in Germany. Only three series of small, single-hull submarines were built.

The armament of small submarines consisted primarily of torpedoes or mines. In addition, medium-size submarines carried guns for use against merchant ships. Submarine cruisers, built for long-range operations against merchant ships, gave preference to guns over torpedoes.

During World War I, two unarmed cargo submarines were built in ←
Germany for operation between the United States and Germany.

The submarine was fully developed as a submersible vehicle with diesel-electric propulsion by the end of World War I.

A class of submarines (R class) was built in England during World War I for making submerged attacks against submarines running on the surface. The boats had a relatively high submerged speed and a long submerged operating range.

Submarines with these type features will be referred to as submersibles (U-Boats).

CHAPTER II

DEVELOPMENTS SINCE THE END OF WORLD WAR I

During World War I, Germany more than any other combatant was committed to the use of submarines as a means of waging naval warfare. Thus, Germany became a leader in submarine development and had the most experience in the use of submarines. The results of German developments were made available to all navies at the end of the war. Among other things, the big German submarine cruiser became the model for U. S. deep sea submarines as well as for large Japanese and Russian submarines.

In accordance with the provisions of the Treaty of Versailles, no submarines were built or maintained in Germany immediately after the war.

The Washington Naval Conference of 1921-22 failed to agree on submarine construction. However, rules were established for calculating the displacement of submarines.

The London Naval Conference of 1930 restricted the total submarine tonnage of the United States and Great Britain to 150,000 tons and that of Japan to 105,500 tons. The submarine was simply defined as "a vessel designed for use under the surface of the water."

The German-Anglo Naval Treaty of 1935 permitted Germany a tonnage equal to that of Great Britain, but Germany voluntarily agreed not to exceed 45 percent of the British submarine tonnage.

In the period between the two world wars, developments consisted mainly of improved features for submarines whose basic lines were those of World War I.

"Wakeless" (i.e., air-bubble-free discharge) torpedoes were introduced in Germany, and super-heavy torpedoes were developed in Japan. Bottom mines with magnetic fuzes, which are difficult to sweep, were developed in Germany. Light air defense weapons were added to the gunnery. Some big submarines carried hydroplanes, which were housed in large hangers.

Submergence depth and protection against explosion were increased by using stronger steel and by introducing electric welding. Engine stability and efficiency were increased by improving the design of the diesel

engines and electrical installations. However, although surface speed increased slightly on the average, the underwater speed remained the same.

Listening devices were developed which enabled submarines to pick up an enemy while remaining submerged to escape detection.

Communication equipment was improved. Submarines could transmit over long distances while operating on the surface and could receive communications by radio while running at periscope depth, thus improving tactical capabilities. The use of submarines had, at least in part, been planned in conjunction with surface fleets. In this case, for example, the maximum surface speed of the big American and Japanese submarines was adapted to the speed of the surface fleet. ←

In the meantime, antisubmarine warfare (ASW) tactics improved as a result of the development of active underwater tracing devices (asdic or sonar) and more effective depth charges. For this reason, it was by no means clear at the beginning of World War II whether single submarines could operate effectively in enemy ocean areas. If submarine detection devices were really as effective as claimed, a single submarine would surely fall victim to a searching combat unit.

The first phase of World War II showed that the submarine could generally defend itself against the type of ASW waged by light surface forces. The range of the ASW devices proved to be so short in comparison to the enormous ocean areas that the possibility of their detecting a submerged submarine was extremely low in the absence of other clues. "Contact" by asdic or sonar was usually accomplished after the submarine had already attacked.

When attacked, German submarines proved able to dive much deeper than their peacetime requirements. A submarine at maximum depth was very hard to hit with depth charges.

At the beginning of World War II (just as in World War I), surface cruising accounted for most of the operating time. Therefore the submarine had to contend with search and attack aircraft during the day.

Because diving time became considerably faster, the submarine had an opportunity to dive before it was spotted by aircraft or, if already sighted, submerge to such depths that it could avoid being hit by aircraft bombs.

Submarines were successful primarily in night surface attacks, but they also had good capability for a submerged day attack by using the periscope.

↙ Radar (1943) placed submarines at a disadvantage. Surfaced submarines could now be detected both at day and night, in clear and overcast weather, by aircraft at very long ranges, and by ships at long ranges. Radar warning devices were subsequently introduced in submarines to indicate when a submarine had been picked up by enemy radar, and, under certain circumstances, gave the submarine sufficient time to dive before it was attacked. But detection devices kept submarines down for longer and longer periods of time, and thus deprived them of their mobility and capability for making surface attacks. Attempts to engage attacking aircraft with heavy guns while on the surface were generally unsuccessful.

American radar-equipped submarines used against Japan were very effective for locating the enemy in the vast ocean areas and for orientation during night surface attacks. Because the Japanese themselves had no effective radar, the effectiveness of radar-equipped American submarines was considerably enhanced without any change in tactics.

↙ Once radar was fitted to ASW units, submarines could stay in areas where the enemy had air or naval superiority only if they remained submerged. This was possible after the installation of the snorkel which enabled diesel engines to operate when the ship was submerged to periscope depth.

However, pre-World War II submarines that had to stay submerged for very long period of time were so clumsy that their success was greatly reduced. Substantial innovations in torpedo armament did nothing to change this.

↙ During World War II, Germany developed torpedoes with homing warheads as well as torpedoes whose path could be changed by remote control; both of these developments increased hit accuracy.

↙ This development naturally led from the true submarine to the pure submersible (capable of remaining submerged continuously) with characteristics that met the requirements for submerged cruising.

Improvements in the electric power installation and in boat shape enabled the speed for submerged cruising to approximately double and the

submerged running time to increase several fold. The snorkel made it possible to charge batteries while at periscope depth. In the same period, similar steps were taken by the Japanese.

The high-horsepower engines for submarines developed in Germany by H. Walter between 1936 and 1945 were not operational at the end of the war. While submerged, these plants operated on a combustion principle; the submarine carried liquid oxygen and was not dependent on a supply of fresh air. Simultaneously, a special hull design was developed for use of this propulsion plant at high submerged speeds. The new hull form was used for the Type 21 and was also influential in the design of the Type 23.

Improved listening devices and active underwater detection devices made it possible for the new submersibles to detect enemies at long range, even while submerged. They could then take advantage of their increased speed for attack purposes. Although boats of the Type 23 were used on several missions shortly before the end of WWII, boats of the big Type 21 never were operational. By the end of the war, however, it was evident that these new types constituted an effective weapon and that the submarine had gained the upper hand in the struggle between submarines and ASW devices. Statistics on the major types of German submarines of World War II are listed in Table 1. Sketches of some of these submarines are shown in the Appendix.

Postwar submarine construction in the United States, France, and the Soviet Union progressed in the direction characterized by the German Type 21. The snorkel was introduced in all navies. Many American submarines were rebuilt and provided with bigger batteries, lighter diesel engines, and appendages that reduced drag in submerged conditions.

Various navies continued developments based on the Walter method, but at the present time, these have not progressed beyond trials.

The majority of the diesel-electric submersibles built after WWII carry torpedoes (for use in part against surface targets and in part against submarines). Some radar reconnaissance submarines were built which represented an intermediate type, a cross between a submarine and a submersible. Others were equipped with guided missile launchers.

Diesel-electric submarines have the disadvantages of limited maximum submerged speed (approximately 1 hr) and the need to use the snorkel to

TABLE 1 - MOST IMPORTANT DATA ON GERMAN SUBMARINES, 1935-1945

Type No. Year	Principal Characteristics	Displacement Data in cubic meters	Principal Dimensions in meters	Weight Distribution in percent	Stability in meters	Steel Structure Dimensions	Depth in meters	Rudders, Diving Planes, Fins, Controls	Torpedo Armament	Gunnery	Propulsion Ratings	Engine Ratings, Fuel Battery Weight	Crew	Remarks
1 2b 1935	Submarine, coastal, single-hull; torpedoes or mines launched from torpedo tubes.	1. 291 2. 341 3. 435 4. 17.0	1. 42.70 2. 4.03 3. 5.27 4. 3.90	1. 44.7 2. 29.5 3. 8.1 4. 7.5 5. 5.0 6. 100.0	1. 0.300 2. 0.311	1. 4.00 2. 1.5 3. 60.0 4. 150 x 7	1. 100 2. 250	Rudders, Diving Planes, Fins, Controls	1. Ratio of surface weight to no. of torpedoes carried (tons per torpedo)	1-2 cm	1. 13.0 2. 7.0 3. Submerged electric speed (k) 4. 2700/10 5. 43/4	1. 2 x 350 2. 2 x 180 4. 21 6. 27.1	25	Refer to Table 2 Type 2 advanced developments: Type 2b: considerably increased fuel capacity advanced development; Type 2c: minor modifications, advanced development; Type 2d: considerably increased fuel capacity as a result of outboard fuel tanks
2 7c 1939	Submarine, seagoing, medium cruising range; hybrid between single-hull and double-hull boat; torpedoes or mines launched from torpedo tubes.	1. 762 2. 871 3. 1150 4. 14.3	1. 67.10 2. 6.23 3. 6.00 4. 4.78	1. 41.5 2. 28.3 3. 7.5 4. 14.7 5. 3.9 6. 100.0	1. 0.388 2. 0.281	1. 4.70 2. 1.85 3. 60.0 4. 200 x 12	1. 100 2. 250	Double rudders aft of propeller, after planes aft of propeller, fixed bow planes, small turning radius, good depth control characteristics, short diving time.	Four bow tubes One stern tube Seven reserve torpedoes plus two reserve torpedoes in upper deck containers 1. 55	1-8.8 cm 1-2 cm Later 1-3.7 cm 2-2 cm Twin mounts	1. 17.0 2. 7.6 4. 7400/10 5. 80/4 6. 61.9	43/50	Refer to Table 2 Type 7 advanced developments: Type 7a: more powerful diesels, increased fuel capacity, advanced development; Type 7b: further increase in fuel capacity, advanced development; Type 7c: with additional section to accommodate 15 anchored mines; also developed from Type 7c; for resupply (support submarine)	
3 9b 1939	Submarine, long-range, sea-going, double hull; torpedoes or mines launched from torpedo tubes.	1. 1027 2. 1178 3. 1430 4. 14.7	1. 76.50 2. 6.70 3. 5.86 4. 4.70	1. 38.4 2. 28.2 3. 13.2 4. 4.3 5. 6.4 6. 100.0	1. 0.575 2. 0.230	1. 4.40 2. 1.85 3. 70.0 4. 200 x 11	1. 100 2. 250	Double rudders aft of propeller, after planes aft of propeller, fixed bow planes, small turning radius.	Four-bow tubes Two stern tubes Six reserve torpedoes plus eight reserve torpedoes in upper deck containers 1. 51	1-10.5 cm 1-3.7 cm 1-2 cm Later 1-3.7 cm 2-2 cm Twin mounts	1. 18.2 2. 7.3 4. 12000/10 5. 64/4	47/53	Refer to Table 2 Type 9 advanced developments: Type 9a: with slightly increased fuel capacity advanced development; Type 9b: with considerably increased fuel capacity advanced development; Type 9c: with more powerful diesels (FPB types), also developed from Type 9c; Type 9d: with two auxiliary diesel generators and greatly increased fuel capacity	
4 14 1941	Submarine, long-range, sea-going, double hull, supply for combat submarines.	1. 1731 2. 1950 3. 2360 4. 12.6	1. 76.10 2. 9.35 3. 8.39 4. 6.70	1. 33.6 2. 16.1 3. 1.3 4. 38.7 5. 5.6 6. 100.0	1. 0.736 2. 0.320	1. 4.90 2. 2.15 3. 80.0 4. 220 x 12	1. 120 2. 300	Double rudders aft of propeller, after planes aft of propeller, fixed bow planes, small turning radius.	No torpedo armament Four torpedoes in upper deck supply combat submarines 1. --	2-3.7 cm 1-2 cm	1. 14.4 2. 6.2 4. 12300/10 5. 56/4	53/60	Refueling possible in submerged operation.	
5 21 1944	Submersible, extremely long-range, seagoing, double hull, torpedo armament.	1. 1602 2. 1800 3. 2100 4. 12.3	1. 76.70 2. 6.61 3. 7.70 4. 6.24	1. 40.2 2. 30.0 3. 4.7 4. 14.9 5. 3.6 6. 100.0	1. 0.382 2. 0.399	1. 5.30 2. 2.6 3. 80.0 4. 240 x 11	1. 133 2. 330	Rudder midship, after planes aft of propeller, stabilizing fin, bow planes retractable, large turning radius, very good depth control characteristics.	Six bow tubes Fourteen reserve torpedoes Rapid reloading capability 1. 80	2-3 cm Twin mounts	1. 15.5 2. 17.0 4. 15500/10 5. 285/6	47/56	Refer to Table 3.	
6 23 1944	Submersible, coastal, predominantly single hull, torpedo armament.	1. 228 2. 236 3. 293 4. 12.3	1. 34.70 2. 4.06 3. 4.06 4. 3.66	1. 40.8 2. 36.0 3. 6.3 4. 4.1 5. 4.6 6. 100.0	1. 0.193 2. 0.329	1. 3.00 2. 1.15 3. 55.0 4. 140 x 7	1. 100 2. 250(?)	Rudder aft of propeller, after planes behind propeller, stabilizing fin, fixed bow planes, very short diving time, very good depth control characteristics.	Two bow tubes No reserve torpedoes 1. 114	--	1. 9.5 2. 12.5 4. 2800/8 5. 175/4	14	Refer to Table 3.	
7 180 1939	Submersible, experimental for Walter propulsion systems, predominantly single hull, unarmed.	1. 71.0 2. 76.0 3. 85.5 4. 7.0	1. 22.05 2. 2.10 3. 3.53 4. 3.20			1. 2.10 2. 0.8 3. 50 4. 100 x 65	1. 100 2. 250	Rudder aft of propeller, after planes aft of propeller, stabilizing fin, no bow planes, very good depth control characteristics in the higher speed ranges.	Unarmed	--	3. 28.0 6. ca 50/28	4	Refer to Table 4 and Figure 49.	
8 17 1942	Submersible with Walter propulsion system, coastal, predominantly single hull, torpedo armament.	1. 277 2. 309 3. 374 4. 11.5	1. 39.0 2. 3.30 3. 5.60 4. 4.30	1. 38.0 2. 25.3 3. 3.7 4. 21.9 5. 4.6 6. 100.0	1. 0.200 2. 0.350	1. 3.30 2. 1.5 3. 60.0 4. 160 x 10	1. 125 2. 300	Rudder aft of propeller, after planes aft of propeller, stabilizing fin, no bow planes, no depth control at slow speeds, very good depth control characteristics in the higher speed ranges.	Two bow tubes Two reserve torpedoes (All torpedoes 5 m in length) 1. 55	--	1. 8.5 2. 6 3. 25 4. 3000/8 5. 40/4.5 6. 110/25	19	Refer to Table 4 Type 17 Advanced development: Type 17 (series) with bow planes, snorkel, and reduced turbine rating (never completed).	
9 26 1945	Submersible with Walter propulsion system, medium-range seagoing, double-hull, torpedo armament.	1. 853 2. 938 3. 1160 4. 10.0	1. 56.2 2. 5.45 3. 4.45 4. 5.95	1. 42.4 2. 23.0 3. 2.0 4. 26.0 5. 3.2 6. 100.0	1. 0.208 2. 0.309	1. 5.40 2. 2.6 3. 80.0 4. 240 x 12	1. 133 2. 330	Rudder aft of propeller, after planes behind propeller, stabilizing fin, bow planes retractable.	Four bow tubes Sixteen reserve torpedoes 1. 85.3	--	1. 11 2. 10 3. 24 4. 7300/10 5. 100/4 6. 150/24	33	Refer to Table 4 Never completed, scrapped in shipyard.	

charge batteries. The submarine is exposed to increased danger when snorkeling because it radiates more noise. The snorkel head can be picked up by enemy detection devices (even though only to a limited extent); moreover, the submarine must remain at a constant shallow depth during the snorkeling operation. The nuclear-powered plants later developed in the United States avoided these disadvantages. A nuclear plant generates very high speed and gives the submarine unlimited submerged cruising range. Approximately 40 nuclear-powered submarines have been built in the United States since 1954. Some of these are torpedo attack submersibles and others are provided with guided missiles. The Soviet Union also has nuclear-powered submarines, and England and France are each constructing one nuclear-powered submarine. Because of their size, nuclear-powered submarines cannot be used in coastal waters. Their numbers are restricted because of the high costs of construction.

CHAPTER III

CHARACTERISTICS OF SUBMARINES

There are submarines for both military and nonmilitary (commercial) uses.

Military submarines may be equipped with torpedoes, mines, and guns for use against surface targets, antiaircraft (AA) guns, and missiles. The individual weapon systems include detection and fire-control installations. Submarines can also serve as logistics support vessels to supply other submarines with fuel, food, and ammunition; as transports for war material; and as radar picket stations they can be equipped to carry seaplanes, submersible craft, and underwater demolition teams. Submarines are now able to take over many combat and escort missions which previously could be undertaken only by surface ships.

Commercial submarines have also been given consideration for certain tasks. Designs have recently been drawn for nuclear-powered, high-speed submarine tankers of large displacement. No thought has yet been given to construction. In terms of ton load capacity, construction costs would generally be much higher in the case of the submarine than in the case of the merchant ship.

The two German World War I commercial submarines mentioned earlier were temporarily profitable only because of wartime freight rates and because they were used to carry high value cargo.

Submarines are very important as research vessels for hydrographic and oceanographic purposes. The bathysphere of Picard and its successors in France and the United States have reached the greatest depths known thus far. Research submarines can even be used in underwater archeology. In this case, however, they are usually submarines that can be employed only with an escort.

There are also pleasure craft that are similar to small submarines. However, the danger connected with their use has limited their popularity.

In the case of military submarines, a distinction is made between oceangoing and coastal submarines. Oceangoing submarines must be able to remain at sea for long periods of time and this requirement necessitates

greater tonnage. Because they are used in shallow depths and are vulnerable to mines coastal submarines have smaller tonnages.

Submarines to be used primarily in the tropics must have special facilities for housing the crew. Those operating in the polar regions need deicing devices for intake air and, under certain circumstances, reinforcement for operation in ice, special navigation devices, etc.

With respect to the type of cruising, a distinction must be made between submarines and submersibles. The former cruises primarily on the surface and submerges only on occasion. Practically speaking, it is a submersible surface vessel. On the other hand, the submersible cruises mainly under water and surfaces only on certain occasions. Hence the cruising features of the first type are conditioned primarily by the requirements of surface cruising whereas those of the submersible are conditioned primarily by the requirements of submerged cruising. Rapid diving is important for the first type and of secondary importance for the submersible or true submarine.

In terms of design, there is a distinction between single-hull and double-hull submarines (see Figure 2 in Chapter V).

In the case of the single-hull submarine, the pressure hull is the external shell. A second, external shell covers at least the ends of the pressure hull. This second shell usually holds ballast tanks and free-flooding spaces, and it is also used for fixed ballast. Single-hull submarines are no longer being built.

In the case of the double-hull submarine, the pressure hull envelopes only those parts of the boat that are not subject to hydrostatic loads. The outer hull is not pressure-resistant; it holds ballast tanks, diesel fuel, and the ballast and free-flooding spaces.

An intermediate type forms the transition from the single- to the double-hull type.

Submarines have different tonnage specifications. The surface displacement is the displacement corresponding to the weight of the nonsubmerged part of the vessel. The submerged displacement is the displacement corresponding to the weight of the nonsubmerged portion of the vessel plus the weight of the contents of the ballast tanks. The type displacement (standard displacement) is a weight index that was established at the

Washington Conference of 1921-22. It is defined as the weight of the nonsubmerged, surfaced boat minus the following weights: diesel fuel supply, motive means supply, motor oil supply, and water of any type. The type displacement is measured in tons (a long ton is equivalent to 1016 kg (2240 lb)).

The form displacement is the volume (in cubic meters) bounded by the external shape of the vessel. A distinction is made between submerged displacement (volume of the total external form) and surfaced displacement (that portion of the displacement below the waterline).

CHAPTER IV

GENERAL DESCRIPTION OF A SUBMARINE

Figure 1 is a schematic of the interior of a modern submarine which is driven by diesel-electric propulsion and is equipped with torpedoes. The hull design is intermediate between a submarine and a submersible. The design of the superstructures and the arrangement of the machinery indicate that the features of the pure submersible are dominant. The construction is that of a single hull boat with a second envelope at the ends. Most of the diesel fuel is stored inside the pressure hull. In a double-hull submarine, the diesel fuel would all be stored outside the pressure hull.

The pressure hull is cylindrical amidships and at both ends has conical sections which are connected to closure plates. A pair of ballast tanks is located in the midship section of the pressure hull, but functionally they are not part of the pressure hull.

Five bulkheads divide the pressure hull into six compartments, every second one of which has an escape hatch.

The aft compartment contains the electrical equipment for propulsion, the switchboard, the pressure-resistant duct of the propeller shaft, the thrust block, the controls for the vertical rudder and stern planes, the aft pair of trim tanks, and a part of the fuel supply.

The second compartment (engineroom) contains the diesel generators and has a double access hatch leading to the upper deck. The main fuel tank and the engine lubrication oil supply tank are located below.

The third compartment contains the space for the aft battery including a part of the storage battery. The fresh water tanks are located at the sides. Quarters for officers and noncommissioned officers (NCO) are located above the battery room along with a storeroom, head, washroom, and galley.

The fourth compartment consists of the control room. Its upper section houses the steering gear controls and instruments for operation of the vessel, e.g., vertical and horizontal control stations, the bilge pumps including the water station and the sea valves, the trim equipment, the compressed air station, and the controls for venting the ballast tanks.

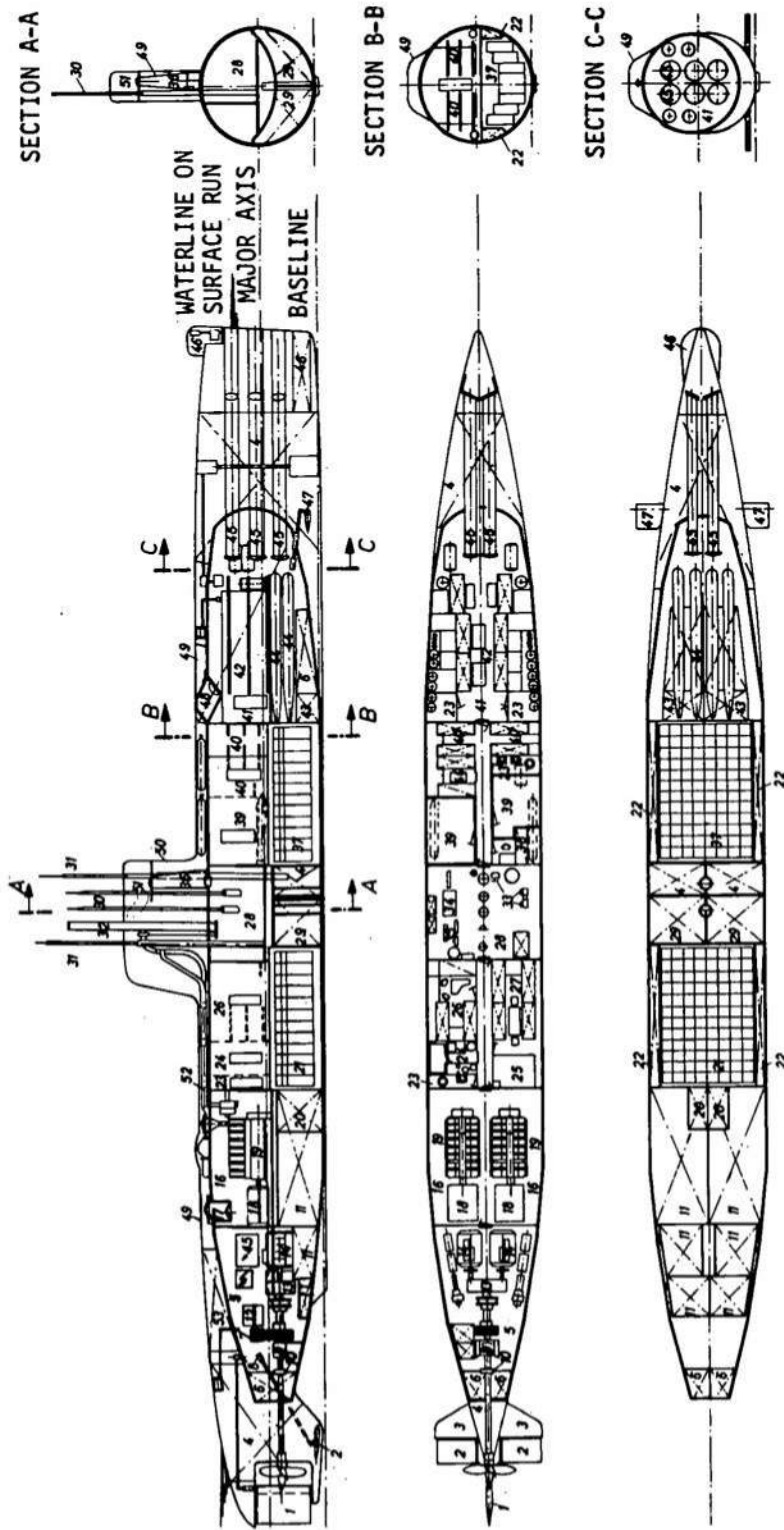

Figure 1 - Interior of a Diesel-Electric Propulsion Submarine

Legend to Figure 1:

- | | | | | | |
|-----|---------------------------|-----|---|-----|---|
| 1. | VERTICAL RUDDER | 19. | DIESEL ENGINE | 36. | ACCESS HATCH |
| 2. | STERN PLANES | 20. | ENGINE LUBE OIL SUPPLY TANK | 37. | BATTERY ROOM FORWARD WITH PART OF THE BATTERIES |
| 3. | STABILIZER | 21. | BATTERY ROOM AFT WITH PART OF THE BATTERIES | 38. | CAPTAIN'S QUARTERS |
| 4. | BALLAST TANK | 22. | FRESH WATER TANK | 39. | RADIO AND SONAR ROOM |
| 5. | STERN AREA | 23. | HEAD AND WASHROOM | 40. | NCO QUARTERS |
| 6. | TRIM TANK | 24. | GALLEY | 41. | BOW AREA |
| 7. | BALLAST TANK VENTING | 25. | STOREROOM | 42. | ENLISTED MEN'S QUARTERS |
| 8. | STEERING GEAR MOTOR | 26. | OFFICERS' QUARTERS | 43. | TORPEDO-STOWAGE COMPARTMENT |
| 9. | THRUST BLOCK | 27. | NCO QUARTERS | 44. | SPARE TORPEDO |
| 10. | STUFFING BOX | 28. | CONTROL CENTER | 45. | TORPEDO TUBE |
| 11. | INBOARD FUEL TANK | 29. | COMPENSATING TANK | 46. | TRANSDUCER OF DETECTION DEVICE |
| 12. | ENGINE FOR SILENT RUNNING | 30. | PERISCOPE | 47. | BOW PLANES |
| 13. | TRANSMISSION | 31. | WHIP ANTENNA | 48. | TORPEDO LOADING HATCH |
| 14. | CRUISING ENGINE | 32. | SNORKEL | 49. | SUPERSTRUCTURE WITH DECK |
| 15. | MAIN SWITCHBOARD | 33. | STEERING STATION | 50. | CONNING TOWER |
| 16. | ENGINEEROOM | 34. | BILGE PUMP | 51. | BRIDGE |
| 17. | HATCH | 35. | WATER AND COMPRESSED AIR STATION | 52. | EXHAUST PIPES |
| 18. | GENERATOR | | | 53. | OUTSIDE FUEL TANK |

The pressure hull in the area of the control room is penetrated by such retractable devices as the periscope, whip antenna, snorkel, etc. The two regulating tanks are located in the lower section of this compartment; the midship ballast tanks which are open to the sea through floor slits are located forward of them.

The lower section of the fifth compartment contains the forward battery room with part of the battery. The fresh water tanks are located alongside the battery room. Quarters for the captain and the NCO's are located above the battery room as is the radio and sonar room.

The forward compartment (bow area) ends at the forward bulkhead which is penetrated by the six torpedo tubes. The after third of these tubes extend into this area. This compartment also contains storage space for six spare torpedoes. Two fresh water cells, two torpedo cells, the forward pair of trim cells, and the bow plane motor are also located under the torpedo storage compartment. The area aft of the torpedo tubes serves as quarters for the enlisted men and includes a head and a washroom. The double torpedo loading hatch is located in the upper section of the aft end and functions as a service hatch when the boat is in port. The anchor windlass motor and the control station for the windlass (which is located outside) hang under the deck of the compartment. A torpedo-loading device can be assembled for loading torpedoes, but the forward quarters must be partly dismantled for this purpose.

The outer hull envelopes the conical sections of the pressure hull fore and aft. A free-flooding narrow superstructure above the pressure hull connects the forward and aft sections of the outer hull. The conning tower is located amidships, and the keel is arranged below the pressure hull.

The aft section of the outer hull contains the aft ballast tank, the mountings for the vertical rudder and the stern planes, and a stabilizer fin on either side. The stern tube with the propeller shaft and the rods for the vertical rudder and stern planes pass through the ballast tank.

The forward section of the outer hull contains the forward ballast tank. The torpedo tubes run through the ballast tank. Forward they are supported by the torpedo bulkhead that forms the forward bulkhead of the ballast tank. The area forward of the torpedo bulkhead is free flooding.

It contains the pressure-resistant muzzle shell covers which are paired with corresponding covers in the outer shell. The mountings for the bow planes and the hawser pipes in the free-flooding area are below the forward ballast tank. The forward, lower section of the free-flooding area is constructed as a balcony for the hydrophone transducer. Above it is a dome for the sonar.

The free-flooding superstructure above the pressure hull is provided with a narrow bridge deck which contains the ducts for the ventilation system and the exhaust system in its after section. The anchor windlass is located forward. The after hatch trunks and the torpedo hatches penetrate the superstructure and are sealed by paired hatch covers at deck level.

The free-flooding conning tower is streamlined and high enough to completely contain such retractable devices as the periscope, snorkel, and antenna. The superstructure encloses the pressure-resistant access opening with the hatch whose upper part contains the cockpit-like surface control.

The keel structure contains ballast for stabilization and is so rigidly installed that the submarine can dock on it.

CHAPTER V

DIVING AND STABILITY

DIVING

The submarine has two floating conditions, one on the surface and the other submerged. In either case, Archimedes principle has to be applied. The transition from surface to submerged cruising is achieved by flooding the ballast tanks. They are empty for surface cruising and completely flooded for submerged cruising.

The diving process may be interpreted in two ways. In the first interpretation, the water used to flood the ballast tanks may be considered as ballast, increasing the weight of the submarine by the weight of the water. At the same time, the volume of the submarine increases. The center of buoyancy and, in most cases, the center of gravity shift with respect to height as well as length. The diving process is completed when the ballast tanks are filled and the vessel is submerged. The vessel is now heavier and displaces its own weight. This interpretation is common in foreign countries.

The second interpretation has been used in Germany since about 1938. The water used to flood the ballast tanks during the dive is not considered part of the submarine weight, and so the weight of the submarine is the same on the surface as when submerged. The center of gravity also remains the same with respect to height and length on the surface as when submerged. During surface cruising, the ballast tanks are empty, when the boat submerges they are filled. Thus on diving, the only change is the center of buoyancy with respect to height, and usually with respect to length, because the pressure-resisting parts above the waterline are submerged and the displacement of the content of the ballast tanks is eliminated. This interpretation is easier to use during the design phase. Unless otherwise indicated, this is the interpretation that will be used in what follows.

The pressure-resisting displacement ($V_u + V_o$) includes (Figure 2) the displacement of the pressure hull at the outer edge of the hull and additionally outside the pressure hull, all structural members making up the ballast tanks, fuel tanks and free-flooding areas, as well as the stern tube, propeller, pressure-resistant piping (ventilation ducts), compressed air flasks, retractable equipment (periscopes, antennas, etc.) and, finally, the fuel tanks outside the pressure hull.

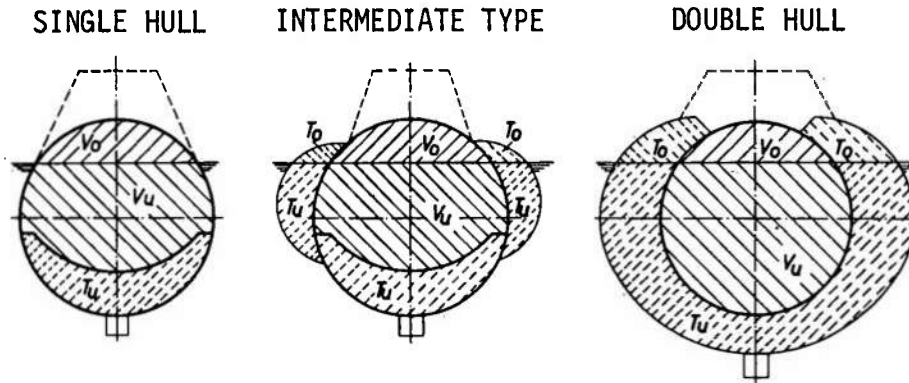





Figure 2 - Displacement Relationships for Submarines

In figure 2,

 V_u is the pressure-resisting displacement below the line of flotation in cubic meters,

 V_o is the pressure-resisting displacement above the line of flotation in cubic meters,

 T_u is the content of the ballast tanks below the line of flotation in cubic meters,

 T_o is the content of the ballast tanks above the line of flotation in cubic meters,

 is the free-flooding area,

p is the weight of the boat in Mp, and

γ is the density of sea water in $[Mp/m^3]$

Thus, the following relation is valid:

For surface cruising:

$$p = \gamma(V_u + T_u)$$

For submerged cruising:

$$p + \gamma(T_u + T_o) = \gamma(V_u + T_u + V_o + T_o)$$

From these:

$$\gamma(V_u + T_u + T_u + T_o) = \gamma(V_u + T_u + V_o + T_o)$$

and thus:

$$T_u = V_o$$

Thus, a submarine that is ready to dive must have an underwater weight that corresponds to its displacement. The weight has to be varied only according to the density of the sea water. If the submarine dives in denser water, it should be made heavier.

Maximum and minimum densities that may be encountered must be established for design purposes in order to keep a submarine submerged. E.g., the oceans and their bordering seas have a sea water density of 1.025-1.028. The Baltic Sea has a density of 1.012 but drops to 1.005 in the Eastern Baltic. Large areas near estuaries consist of almost pure fresh water.

When the submerged vessel is trimmed so that it floats on an approximately even keel without reserve or negative buoyancy, the submarine is said to have "neutral trim without reserve buoyancy."

When a submarine of this type surfaces by blowing its tanks, i.e., by emptying its ballast tanks, it can float on the surface on a fixed trim only as long as the weight condition of the controlled state is maintained. This surface trim condition depends on the shape of the submarine and on the location and size of its ballast tanks. All the consumable items on board, such as stores, fresh water, and fuel, must be compensated for within the submarine by changing the counterweights. Thus, when a submarine is on the surface and "ready to dive," it is impossible to tell whether it is completely loaded with fuel and supplies or whether some of these items have been consumed.

When a submerged submarine without engine power is considered to be neutrally trimmed, it is assumed to be acting in accordance with Archimedes principle. Actually, this is not entirely possible because a state of equilibrium can be obtained only approximately when submerged. The pressure hull is elastic and sea water is only slightly compressible. The pressure hull compresses as the submarine dives; thus the pressure-resisting displacement is eliminated, and the submarine sinks more rapidly. The analogous condition achieved by a balloon floating in the air cannot be established under water if the sea water density is assumed to remain almost constant.

A vessel can remain in the stopped condition at a specific depth under water only by alternately flooding and blowing tanks. This condition can be reached automatically by a depth control system that floods and drains the regulating cells. The diving pressure serves as the impulse transmitter. The desired depth can be set on this device.

However, there are certain areas, the Strait of Gibraltar, for example, where there are distinct strata of sea water with different densities. A vessel can drop into one such layer and remain above a denser layer. It can penetrate the denser layer only by taking on more ballast water.

ARRANGEMENT OF THE TANKS WITH RESPECT TO THE REQUIREMENTS FOR SUBMERGED CRUISING

Ballast Tanks

Ballast tanks provide the vessel with the buoyancy necessary for surface cruising (Figure 3). They are empty during surface cruising and completely flooded during submerged cruising. They are communicating with the open sea during submerged cruising and thus are not included in the pressure-resisting displacement. On the surface, the submarine floats on the air cushions in the ballast tanks which are under internal pressure on the surface. The pressure height is determined by the distance between the waterline of flotation and the lower openings of the ballast tanks.

These lower openings of the ballast tanks are slit-shaped and located as deep as possible. During the dive, air escapes through air vents or flaps; these are located on top of and as far to the rear of the ballast tanks as possible because the dive maneuver makes the ship bow-heavy. The diving process starts by opening the valves fast. The valves are closed again after the maneuver is completed.

At one time, some of the flood openings of the ballast tanks were fitted with flood flaps that were always kept open when the vessel was preparing to dive. They also provided an extra guarantee of submarine floatability during surface cruising when the vessel was not able to dive or while in port.

Preparations for surfacing begin by blowing the flooded ballast tanks with compressed air. The submarine then rises; after it has broken the surface, the conning tower hatch can be opened. The rest of the water is then blown out by low-pressure compressed air furnished by a blower or by the diesel engine exhaust gas. Atmospheric air needed for the blowing process is sucked through the open conning tower hatch or an open air

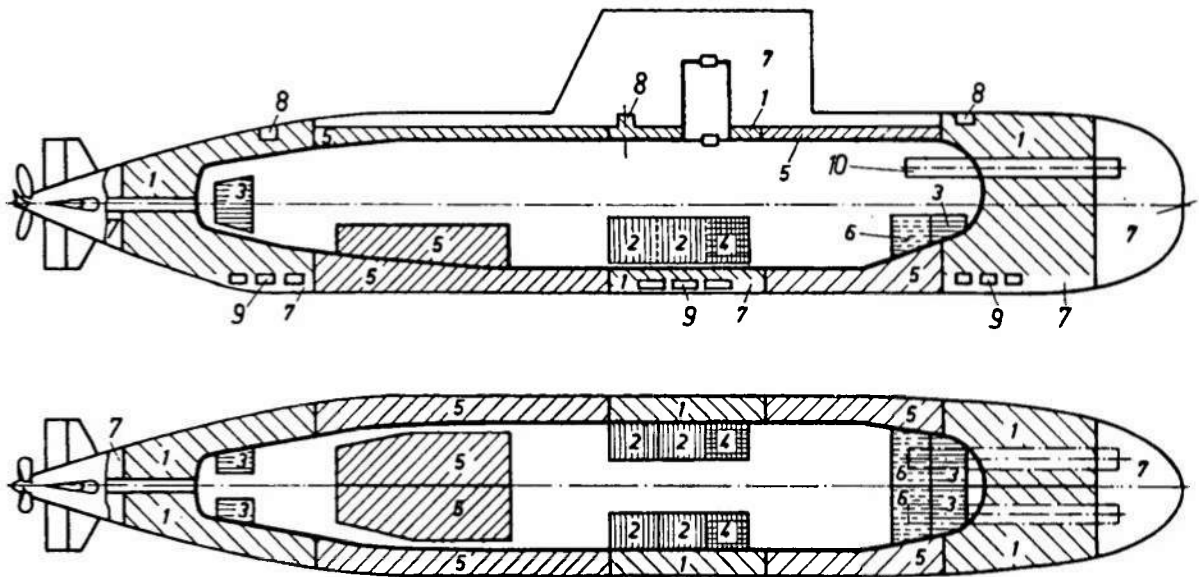

- | | |
|--------------------|-------------------------------|
| 1 BALLAST TANK | 6 TORPEDO TANK |
| 2 REGULATING CELLS | 7 FREE-FLOODING AREA |
| 3 TRIM TANK | 8 BALLAST TANK VENT |
| 4 NEGATIVE TANK | 9 FLOOD SLIT FOR BALLAST TANK |
| 5 FUEL TANK | |

Figure 3 - Arrangement of the Principal Tanks in a Double-Hull Submarine

feeder mast. The blowing process is completed when air, or diesel exhaust gas, ascends from the flood slits.

A special blowing installation may not be provided for simple or small submarines. In such cases, the entire ballast tank volume can be blown by compressed air.

The volume of the ballast tanks is approximately 10 to 30 percent of surface displacement. Diving submarines, for which seaworthiness is important, have a larger ballast tank volume than do submarines that run primarily submerged. Larger submarines can manage with a relatively smaller ballast tank volume than smaller submarines.

The shortest time for ballast tank flooding is approximately 10 sec. Flooding usually takes longer for submersibles than on submarines. Ballast tanks located deep below the waterline require smaller openings for a given flooding time than do tanks located higher up.

When leaving a drydock or a floating dock, a submarine must blow its ballast tanks with compressed air in order to establish the previously mentioned internal pressure; otherwise draft will be greater and the designed reserve displacement will not be available.

Regulating Cells

Regulating cells serve to control the weight of the boat to correspond to the submerged pressure-resisting displacement. These regulating cells are arranged amidships and as close as possible to the longitudinal center of gravity of the submerged pressure-resisting displacement. They are within the pressure-resisting displacement and can be flooded or blown by choice. The tanks can be emptied by a pump; compressed air can also be used and makes less noise. In this latter case, the regulating tanks must be so pressure resistant that they can withstand an internal pressure that is greater than the diving pressure. The regulating tanks are provided with vent ducts which lead into the inner submarine.

There are two or sometimes four regulating tanks. With four tanks, the operation may be as follows. Two regulating tanks operate as flood regulators with open vents. The other two are employed to empty the tanks silently by way of compressed air. Their vents are closed. One is operated by a compressed air cushion at medium pressure; it serves as a "shallow

blowing regulator" when the ship is running at periscope depth. The other has a compressed air cushion at high pressure; it serves as a "deep blowing regulator" and is always available for blowing tanks when the vessel dives to maximum depth.

→ The following weight differences must be compensated for by the regulating tanks:

1. Differences in the specific weight of the sea water. If the submarine dives where sea water density ranges between 1.005 and 1.025, there must be compensation for a weight difference of 2 percent of the pressure-resisting displacement.

2. Decrease in volume during deep dives. Here approximately 0.3 percent of the pressure-resisting displacement is necessary. This amount represents the minimum filling which has to be available in the regulating tank during surface cruising in order to maneuver the submarine in even the greatest depth.

3. Compensation for the consumption of food, fresh water, lube oil, and other supplies during the voyage.

4. Partial compensation for the consumption of diesel fuel. Diesel fuel is stored floating on water. When 1 cubic meter of diesel fuel is used, it is replaced by 1 cubic meter of sea water. The extra weight thus added must be compensated for in the regulating tank.

The special calculations made to determine the size of the regulating tanks take into account the border cases of the loading. The following loading conditions may occur as border cases for a particular submarine type:

Case 1 - the condition at the end of a very long, slow cruise in sea water with maximum density. For example, at the end of a very long, slow cruise during which food, fresh water, and supplies have been used up but a relatively large amount of fuel is still left, the vessel is cruising in water with the maximum required density. In this case, the regulating tanks should be filled to the maximum.

Case 2 - the condition at the end of a very short, fast cruise in sea water with minimum density. For example, at the end of a very short, fast cruise during which food, fresh water, and supplies have been only partially used up but the fuel is completely gone, the vessel is cruising

in water with the minimum required density. In this case, the regulating tanks should contain a minimum of water, only enough to compensate the weight for the reduction in volume during deep diving.

When the fully equipped submarine begins its cruise, the actual filling of the regulating tanks usually lies somewhere between these two border cases. The regulating tanks usually have a volume 2.5 to 3.0 percent of the pressure-resisting displacement. ↙

Trim Tanks

The trim equipment serves to bring the center of gravity vertically beneath the submerged displacement center so that the vessel can be maneuvered into a neutral trim condition. The trim tanks, which are equal in size, are located inside the pressure-resisting displacement and as far forward and aft as possible. The trim tanks are connected by the trim ducts. Trim water is moved back and forth, either by pumps or by low-pressure air which operates with less noise. Tank stress calculations depend on the pressure of the compressed air.

There are usually two pairs of trim tanks (see Figure 60 in Chapter XI) if compressed air only is used to trim the submarine. These are connected by a starboard and a port duct. Compressed air is supplied to the forward port tank and the starboard after tank; the stern is trimmed with the port pair and the bow with the starboard pair. When one of the tanks has become empty, the sides can be changed, i.e., air pressure is fed to the port aft tank and the forward starboard tank while the other two tanks are vented. The boat can now be trimmed bow-heavy at port side and stern-heavy at starboard side.

The quantity of water to be trimmed is one-half that of the entire trim tank. Trim tank dimensions are based on calculations that determines the extreme load conditions by a method similar to that for the regulating tanks. Weight shifts that result when torpedoes are fired are also taken into account. The volume of trimming water is approximately 0.5 of the pressure-resisting volume. ↙

Negative Tanks

Negative tanks are used on submarines only as an auxiliary means for diving in waves. When diving in waves, a submarine takes on added buoyancy which hinders the settling. As waves roll across the submarine, their troughs prevent the free-flooding part of the upper deck and the superstructure from being filled completely, and so the submarine may remain "floating" on these free-flooding parts.

A diving maneuver in waves is easiest in broadside waves, more difficult in aft waves, and most difficult in head-on waves.

Flooded negative tanks provide the submarine with additional negative buoyancy during surface cruising. They are located forward of the longitudinal center of buoyancy of the submarine to provide additional bow weight when diving. They can be blown quickly with compressed air after the diving maneuver. Only then can the submarine be trimmed under water. The negative tanks will be flooded immediately after surfacing. They have the same stress as the regulating tanks, and their volume is approximately 0.7 percent of the displacement.

STABILITY

The surface stability of a submarine is different in the longitudinal and transverse directions just as in the case of surface ships.

The transverse metacentric height is calculated as for a conventional ship by taking the free surface into consideration. The free surfaces include particularly the areas of the residual water in the trim tanks. The extent of the stability during surface cruising is usually so great that it is not necessary to calculate the level arms of the static stability. However, the extent of the stability has to be taken into account when dealing with basically new types of boats.

The longitudinal metacenter is usually not calculated because the unit trim moment calculated from it is generally not accurate enough for the surface trim calculation if, as usually is the case, the form of frames deviates too much from the vertical near the waterline.

When cruising on the surface, submarines usually have little reserve displacement compared with surface ships and so tend to roll heavily. This

is particularly apparent when the waves are coming from aft. In this case, the seas can wash over the center section of the line of flotation for some time. As a result, the component of the widest section of the line of flotation is lost to transverse stability, and this results in surprisingly heavy heels.

There is no waterline submerged (Figure 4), and so the metacenter M coincides with the center of buoyancy F , provided that no tanks are inside the submarines with free surfaces.

The submarine is suspended like a pendulum, with its weight at the center of gravity G and its buoyancy at the center F . The stability in both the longitudinal and transverse directions is the same because there is no waterline.

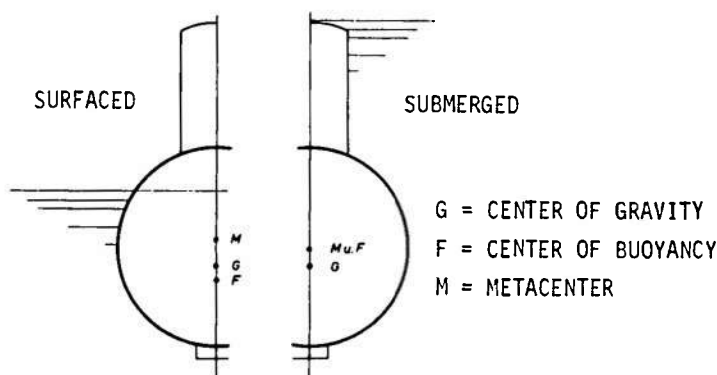

POSITION OF G , F AND M FOR INTERPRETATION 2: DIVING BY SHIFTING DISPLACEMENT

Figure 4 - Stability Relationships

The free surfaces inside the boat reduce this stability slightly and differently in the longitudinal and transverse directions. The value of FG is different depending on whether the dive is considered as added weight (Interpretation 1) or as a change in the form of displacement (Interpretation 2). The corresponding moments of stability are naturally the same for both interpretations. The heeling moments are small when the submarine is submerged. However, the trim moments can be considerable. A submerged submarine is very sensitive to weight shifting along the longitudinal axis because of limited longitudinal stability.

A man walking from fore to aft can cause a noticeable trim during submerged cruising. Thus it is necessary for the crew to remain at specific points ("diving stations").

Since the center of gravity is below the center of buoyancy when the submarine is submerged, it will roll in a circle toward the inside.

There is a transition from surface to submerged stability during settling and rising. This transitional region is investigated by special stability calculations. For some types, particularly double-hull submarines, a very small, sometimes even negative, static stability can be obtained for parts of the surfacing and submerging operations. However since this decrease in stability occurs only for a short period of time, the associated heels are very small. Single-hull vessels are often statically stable during the entire diving procedure.

Heavy heeling will occur if a submarine at a great depth attempts to surface quickly by heavily blowing its ballast tanks, which are located in the bottom of the submarine. This is because the center of buoyancy approaches its lower surface position while there is still no line of flotation to provide a degree of transverse stability with its lateral moment of inertia. As the submarine rises in a state of reduced stability, the superstructure is subjected to a flow from above which can generate a considerable amount of heel. This is the reason why the ballast tanks are usually blown as a submarine approaches the surface.

The free-flooding superstructures cause additional heel if the water remaining in them does not drain rapidly enough when the submarine surfaces quickly.

Submarines that are ready to dive are able to ground because of negative buoyancy. This causes a reduction in stability analogous to the stranding of a surface vessel. The bottom of the keel must be wide enough to keep the submarine upright despite the decrease in stability.

Damaged submarines that run aground by flooding often lose their stability and list heavily.

The moments of stability are determined by surface and underwater heel tests which allow the position of the center of gravity to be calculated in respect to height. These heel tests are similar to those for surface vessels. If there are differences between the surfaced and sub-

merged heights of the center of gravity, it is simply the result of inaccuracies in performing the tests (Interpretation 2 for diving). The surface heel test is much more inaccurate than the submerged heel test for the case of a submarine whose trim tanks have flood slits open, so that the residual water in the ballast tank is in contact with the surrounding water. This explains why the submerged heel test result is preferred; the height of the center of gravity is taken from the submerged heel tests, even for the surface position, and is used to calculate the surface metacentric height. Even a submerged trim test, in which the angle of trim (about the transverse axis) and the corresponding trim moments are measured, will have to yield the same height for the submerged cruising center of gravity because of the above-mentioned equality of longitudinal and transverse stability.

However, it is more difficult to obtain the same accuracy for the submerged trim test as for the submerged heel test.

CHAPTER VI

DYNAMICS

DESIGN OF THE SUBMARINE VERSUS THE SUBMERSIBLE

The diving submarine and the submersible have basically different lines.

The submarine (Figure 5) is expected to be able to develop a fast surface speed with the available propulsive power by maintaining good sea-keeping qualities. Conversely, the submersible (Figure 6) is expected to be able to develop high submerged speed and to have a long cruising range at any speed.

Since the submarine is specifically affected by wave resistance, maximum hull length is a favorable factor with respect to cruising power. Torpedo boat lines were used as the example for the shape of the submarine. The midship section is made as full as possible, and the ends are fine. Flaring frames in the area of the forebody improve seakeeping qualities. The size of the ballast tank (reserve displacement) has a decisive effect on the seakeeping qualities. The ends of the superstructure above the waterline can be designed in the form of a "watertight forecastle" and "watertight stern" in order to improve seagoing qualities.

These spaces have vents at the top and are free flooding below. The vents are opened prior to diving and unlike the buoyancy vents of the ballast tanks, they remain open when submerged. When the ship surfaces, the spaces drain and then the vents are again closed.

The size and configuration of the displacement above the line of flotation and properly balanced stability relationships all have a decisive effect on whether a conning tower remains dry in a seaway. The design of the conning tower itself plays a subordinate role in this respect.

When an upper deck with a large number of venting slits covers larger free-flooding spaces below, then these slits will have a certain leveling effect on breakers and wave crests rolling along the upper deck.

Since the submarine cruises on the surface at constant draft, the design can be in the form of a raised stern (horizontal fairing in the waterline) to yield a greater hydrodynamically effective length. The

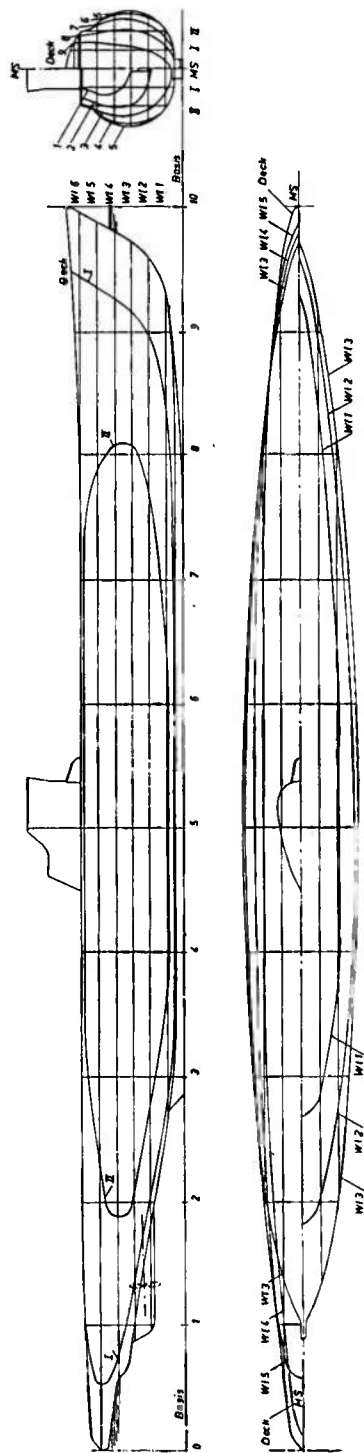

Figure 5 - Lines of a Submarine
(German Type 9 d2, 1942)

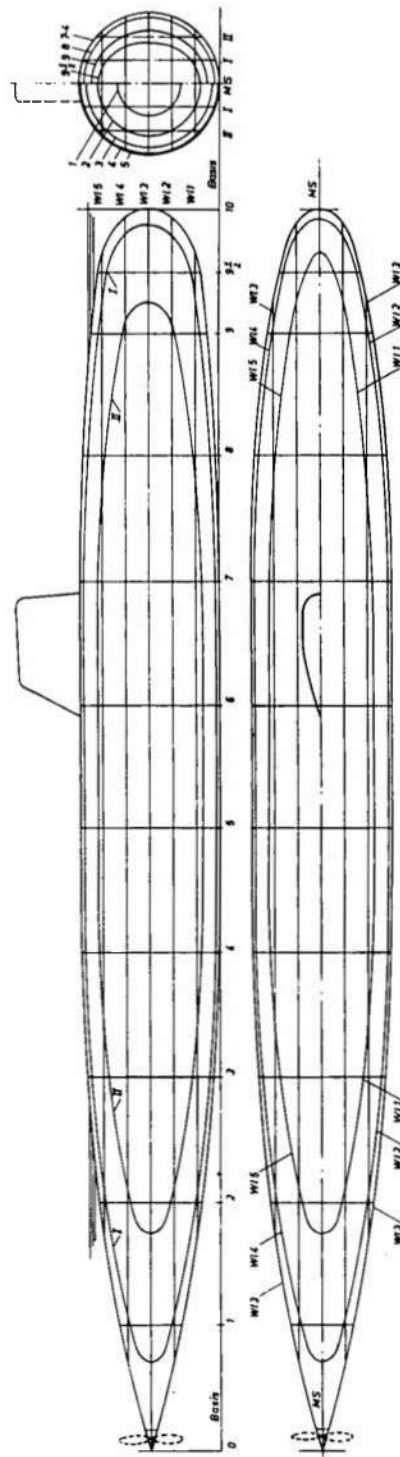

Figure 6 - Lines of a Submersible

propellers are located below the stern because they require a certain degree of immersion (Figure 7).

The lateral plan aft is reduced as much as possible in order to obtain a smaller turning circle. An arrangement of large or dual rudders results in small turning circles (equal to 3 to 3 1/2 ship lengths) which are required for tactical surface action.

The lines adopted are derived from the optimum configurations determined by towing tank tests as far as construction permits (Figure 5).

The appendages are faired and reduced to a minimum. Because of bow resistance, it is particularly desirable to be able to retract, pivot, or fold back the bow planes during surface cruising (see Figure 52 in Chapter XI).

→ It is easier to develop a good surface configuration for a double-hull than a single-hull submersible because the outer hull is more easily shaped. The single-hull submarine is strongly dependent on the cylindrical and truncated cone shapes of the pressure hull because a considerable section of its outer hull is identical with the pressure hull. The intermediate type falls between that of the double-hull and single-hull boats with respect to its surface shape. The shape of the true submarine in submerged condition is by no means bad since it is almost free of flow separation. However, the superstructure and appendages required for surface cruising usually generate so much drag that the overall submerged resistance becomes large. This factor and the low propulsion power available for submerged cruising result in slow submerged speeds.

The true submarine is usually built with twin screws because surface power can only be obtained by two propellers due to the restricted propeller diameter. At the same time, two propellers provide better maneuverability and redundancy in the event one system fails.

→ In the case of the submersible, the entire configuration must be designed for submerged cruising. The shapes of fish and torpedoes are examples of a good configuration. A submersible is not exposed to wave drag when running submerged.

At a depth equal to 4.5 times the diameter of the boat (measured from the center of the pressure hull to the water surface), the wave drag will not yet have disappeared completely in the higher speed ranges.

Consequently, a submersible of 5 m in diameter must dive to 25 m (measured from keel to the water surface) before it can escape the adverse effect of wave drag on its cruising performance in the higher speed ranges. At the slower speeds, however, wave drag is insignificant, even at periscope depth.

The friction drag of water on the surface of the boat is the predominant resistance factor; thus a minimum of surface area is advantageous in order to minimize this drag. This is accomplished for a given displacement by selecting a maximum hull diameter and a minimum length. The fineness of the run must be selected for minimum flow separation.

The forebody and all leading edges of the superstructure and appendages can be rounded, but the stern and protruding edges of the superstructure and appendages must be faired. The lateral plan of the stern is curtailed as much as possible in order to achieve small turning circles in combination with an effective rudder (Figure 8). As a rule, these turning circles are smaller during submerged cruising than during surface cruising and smaller at slow than at high speeds.

The lines of submersibles are not very well suited for surface cruising. The attainable surface speed is generally considerably below the maximum submerged speed. Today the submersible is usually built with a single screw because a single-screw propulsion system is more efficient (see Figure 6).

When the submarine is cruising at periscope depth, i.e., near the wake surface, it will be more exposed to wave action because of its large superstructure and flat deck than will the submersible whose members are smaller. True submarines therefore require larger diving planes than do submersibles.

When the submarine is running at periscope depth, wave energy will interfere with depth control. The magnitude of the interference will vary with sea force. A seaway causes a lift which will affect the boat most when heading into the sea and least in following seas. Depth control in a heavy sea is easiest when proceeding on a course with the sea abeam. A submarine in the open ocean at a depth of 80 m can still roll as much as 8 deg when hurricane force waves are acting on the surface.

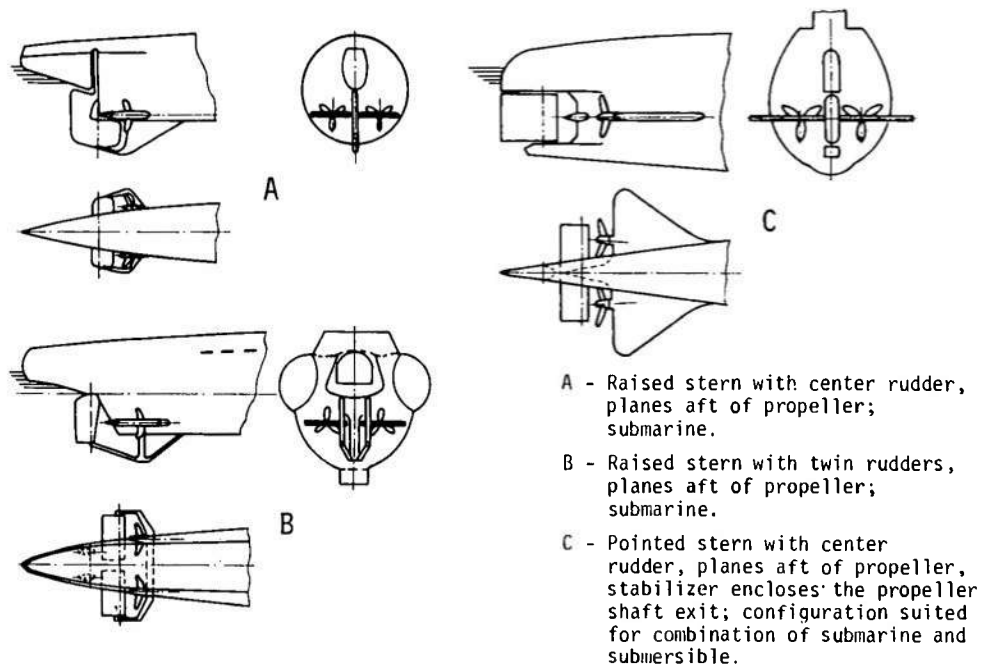

Figure 7 - Twin-Screw Stern Configurations

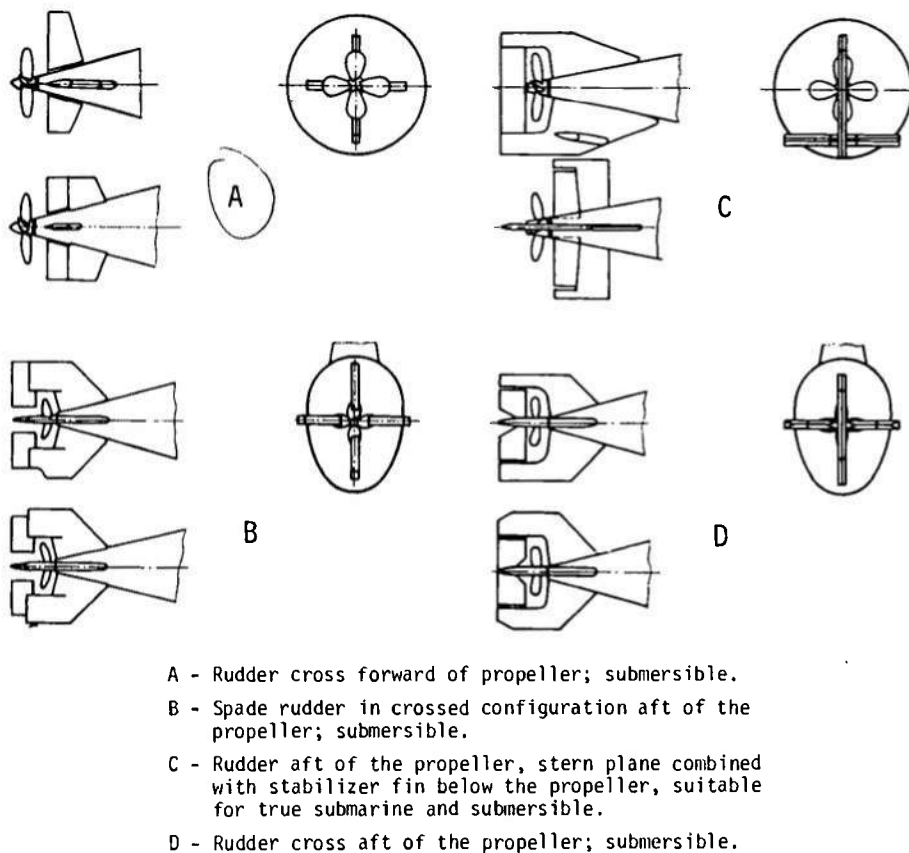

Figure 8 - Single-Screw Stern Configurations

The submersible must be stabilized by horizontal stern fins because of its high submerged speed. The true submarine does not require these fins because of its slower submerged speed.

Some submarines must operate as submersibles as well as true submarines. A compromise must be made to allow for the requirements of both the surface and the submerged cruising (Figure 9). The length of such a boat is governed by the wave formation during surface cruising and is greater than that of a submersible with the same displacement. The forebody is sharp in the area of the waterline and the elongated stern is faired as much as possible.

The upper deck is kept as narrow and smooth as possible because of the submerged speed. The shape of the superstructure is designed for minimum drag. The boat has a single-screw propulsion system because this provides optimum submerged propulsion conditions.

SUBMERGED DRAG

The submerged drag of the hull is composed of frictional and separation drag. The frictional drag on a given surface will be reduced to a minimum if the lines are faired, the paint is in good condition, and there is no fouling. Flow separation drag can be very small when the lines are well faired. However, the considerable drag created by the slits for the main ballast tanks and free-flooding spaces must be added to these drag components.

One slit has a drag four to five times the frictional drag of a plate of the same size. Moreover, these slits can cause additional resistance when longitudinal flow and vortices form within the free-flooding spaces. The energy for these flow phenomena has to be produced by the propulsion system. One way to reduce these internal flow phenomena is the use of adequate lateral subdivision by partition bulkheads and frames within the free-flooding spaces.

Additional drag is caused by the superstructure and appendages such as rudders and stabilizer fins.

Ballards, cleats, and lamps are retractable to avoid additional drag. Rail supports that cannot be removed are faired for low drag (see Figure 10).

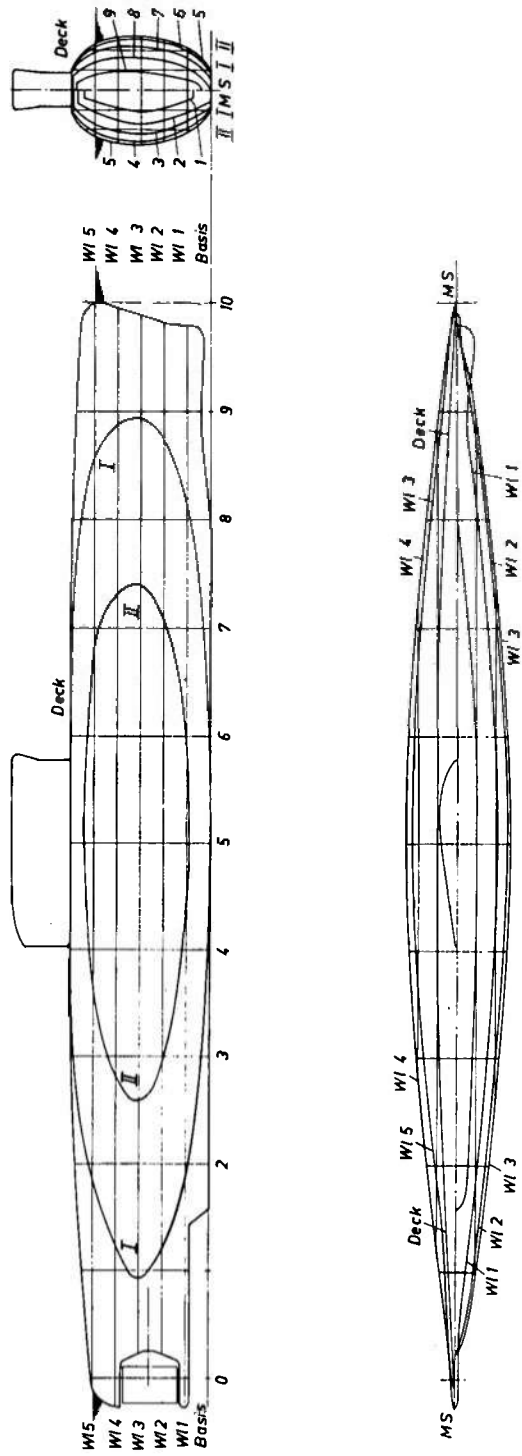

Figure 9 - Lines of the German Type 26 (1944)

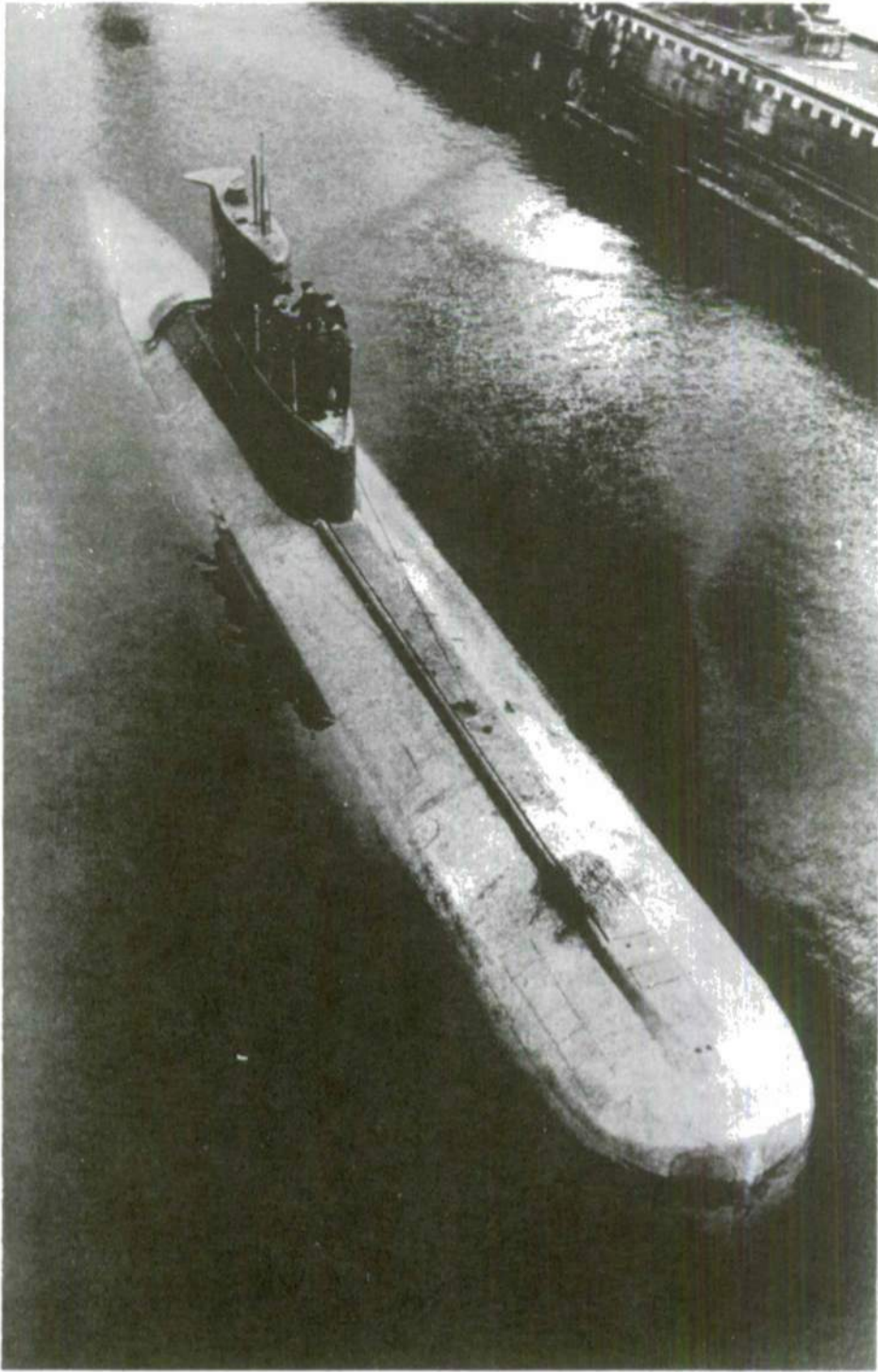

Figure 10 - Upper Deck and Superstructure of Type Based on U2 (1962)

The sum of all drag components is the overall drag when the boat operates at great depth.

The above drag components refer to the condition of the boat when all extensible equipment (periscope, snorkel, antennas, etc.) are retracted. These have considerable drag when extended. For instance, an extended periscope on a submersible of 500-m³ submerged displacement and good lines will cause an additional drag of 30 percent at 4 knots; the drag decreases to 8.5 percent at 10 knots.

The submerged drag increases approximately with the square of the speed.

PROPULSION

A submarine will have different resistance to overcome for surface and submerged speed at the same propeller rpm, and hence the loads on the propeller will differ. Thus it is impossible to design an optimum propeller for a true submarine for both cruising conditions, and a compromise is necessary. The propeller diameter of a true submarine is usually subject to constraints. The propeller blade tips must remain some distance from the surface because of the danger of aeration in a seaway. Moreover, the tips must be high enough above the keel baseline to permit the boat to be grounded. The achievable propulsion efficiencies of a true submarine cruising on the surface is of the same order of magnitude as for surface ships with a comparable propeller load. Cavitation phenomena during surface cruising must be taken into consideration. The propulsion efficiency of a true submarine is usually lower during submerged cruising.

More favorable conditions for a true submarine could be achieved by using variable pitch propellers because the pitch could be adapted to the variable loads during surface and submerged cruising and result in improvement in both cases.

In the case of a submerged submersible, the propeller load will be constant at all speeds because of the squared dependency of drag on speed. This means that the propeller will have the same efficiency at all speeds during submerged cruising.

Water pressure makes cavitation insignificant. It is often possible to select the optimum diameter from the rpm and load. There will be a

significant friction wake in the propeller plane because of the major drag component resulting from skin friction. Much of the propulsion energy can be recovered if the propeller is placed in the concentric wake. This energy recovery of a single-screw submersible is one of the principal advantages of the single-screw over a twin-screw drive.

In summary, single-screw submersibles have a very high propulsion efficiency if they combine low rpm, low propeller load, unrestricted propeller diameter, and propulsion recovery from the wake. This efficiency will be greater than for any other propeller-driven ship.

The propeller efficiency of a submersible cruising on the surface is satisfactory when it is the same as that obtained by a propeller designed for submerged cruising.

DEPTH CONTROL

The following requirements must be satisfied to obtain a maneuverable boat:

1. The submarine must be able to generate buoyancy as well as negative lift forces with its planes. These forces are required to compensate for (a) weight differences in a submersible that is not completely trimmed; (b) adjustments to the boat at constant depth and to balance it against external forces caused by wave action, fired torpedoes, etc.; and (c) depth changes.

2. The submarine must be able to generate moments about its transverse axis by plane action. These moments are required to compensate for free moments in a submarine that is not completely trimmed, to permit trimming at constant depth, to balance out any moments attributable to waves, fired torpedoes, etc., and, finally, to change trim angle.

3. A submarine proceeding at high submerged speed must be stabilized by fins at the stern to the degree where accurate and dependable depth control by plane action is possible. This stabilizing action is caused by weight stability in a submarine proceeding at slow submerged speed so that the fins can be disregarded.

One pair of planes fore and aft are required when running at low-speed rates (Figure 11).

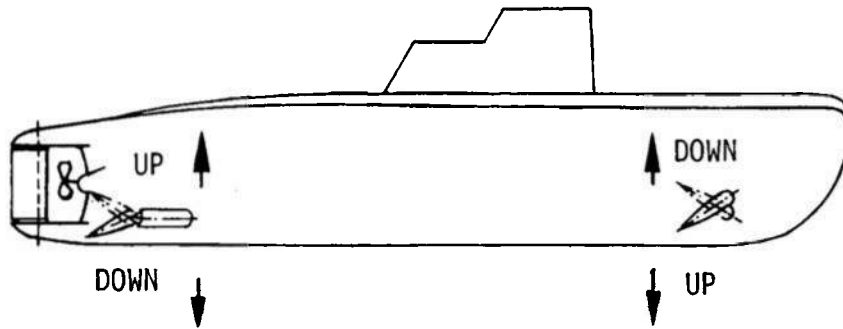

Figure 11 - Plane Positions

An upward tilted bow plane causes a lift (the leading edge is tilted upward). When a submersible with a transverse axis about one-third the distance from the bow is operating in the higher speed ranges, a secondary effect occurs in the form of a trim angle aft so that the hull will generate additional buoyancy.

The stern plane has the opposite effect. When its trailing edge is tilted upward, the downward-directed rudder force causes a stern-down trim angle and the hull generates lift. The magnitude of this angle depends primarily on the distance between the plane and the turning center of the boat as well as on its counteracting weight stability. The difference between the greater buoyancy of the hull and the smaller negative lift of the planes is available as effective buoyancy.

At slow-speed rates, the bow plane is used primarily to generate positive or negative lift and the stern plane is employed to generate trim or to maintain a given trim angle.

There is a so-called critical speed in the low-speed range at which the stern plane alone cannot provide the boat with either positive or negative buoyancy. At this speed, for instance, an upward-directed plane results in a very small stern-heavy trim angle because of the existing weight stability. The buoyancy of the boat in this trim position is as large as the negative lift of the stern plane. Consequently, the effective force will be zero, and the plane action will be ineffective to satisfy Requirement 1.

The stern plane is excellent for maintaining depth at high speeds; the buoyancy and the negative lift will be large at small trim angles. The influence of weight stability will be small compared to the trimming moments generated by the forces of the plane. The stern plane generally provides

more sensitive depth control in the high-speed ranges because of its indirect effect than does the bow plane which has a direct effect on depth.

When proceeding at high submerged speeds, submarines require a stern fin for dynamic stabilization. Because of its destabilizing effect, the bow plane is designed so that it can be pivoted, folded back, or retracted when some predetermined speed has been reached (see Figure 52 of Chapter XI). If the design is such that the plane remains extended in the idle mean position at high speed, the stern fin must be designed proportionately larger. Configurations with pivoting, folding, or retractable bow planes have a dual advantage in terms of drag reduction: they eliminate bow plane drag and require a smaller stern fin.

The direction of hull drag, including superstructure and appendages, the direction of propeller thrust, and the configuration of the stabilizing fins must be in harmony if the submarine is to proceed on an even keel and be free of lifts and moments at any speed.

To summarize, depth control is attainable at slow speeds by using bow planes only, but if in addition some trim angle is required, the stern planes must also be used. The stern plane and the stabilization fin are necessary for depth control at high speeds because of the adverse effect of a bow plane at high speed.

If moved a large distance from their center position, rudders will make the boat stern-heavy and cause the submersible to ascend. This must be compensated for by moving the stern planes downward.

The planes assist in the diving maneuver (see Figure 12). After the main ballast vents are opened, both sets of planes are moved into the downward position. This action and the slower flooding of the after main ballast tank cause the submarine to dive bow first. Leveling off takes place by moving both sets of planes upward. This is followed by a stern-heavy trim of about 5 deg for a short time. (The submarine is made to "pitch" in order to remove the last air bubbles from the main ballast tanks and the free-flooding parts of the superstructure.) The submarine then proceeds in the horizontal attitude, and the main ballast vents are closed. The submarine levels off then by flooding or blowing the regulating tanks and by shifting trim water until at slow speed the planes can hold it at the desired depth by operating with angles about the mean position.

Electrical or mechanical depth control systems have been developed for automatic control at a selected depth. These systems operate the planes by using water pressure and trim position as impulse transmitters.

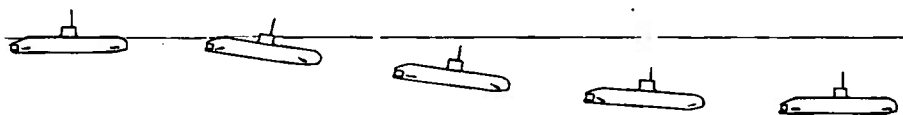

Figure 12 - Plane Positions during a Dive

MODEL BASIN EXPERIMENTS AND SUBMERGED TRIALS

Resistance and propulsion tests are performed in a towing tank under the same conditions as for surface ships. The submerged model is towed in the tank by a vertical faired strut to determine the drag of the hull and the resistance of superstructures and appendages.

The friction drag of the full-scale boat cannot be determined by model tests. This drag is computed for the full-scale hull and added to its flow separation drag.

Propulsion experiments (model with rotating screw) and diving plane force measurements are carried out in the submerged condition. Finally, the lift- and moment-free conditions are measured and the required size and position of the stern fin are determined.

Trial runs are conducted with the completed submarine. The surface and submerged trial runs correspond to the drag and propulsion experiments.

The forces acting on the submarine and attributable to the planes can be determined for different plane angles as follows. First, the submarine is trimmed to an even keel at a certain speed with both planes at zero angle. Then one plane is tilted by a specified angle. The regulating tank is then flooded or blown and trim water shifted until the submarine is once again on an even keel with the tilted planes at the same depth. The water admitted to or blown out of the regulating tank corresponds to the force applied to the boat by the planes. The quantity of trim water shifted will yield the trimming moment generated by the planes.

The Admiralty Constant provides an approximate evaluation of the submerged propulsion performance of different submarine types:

$$C = \frac{D^{2/3} \times v^3}{N_w}$$

where D is the submerged displacement in cubic meters,
v is the speed in knots, and
 N_w is the effective surging power in horsepower.

This formula yields useful comparative data for submerged boats but may be applied to surface ships only with great reservations and therefore is rarely used today. This formula takes into consideration the law of the square of the drag in the submerged cruising condition and, consequently, the cubic dependence of power on speed. Moreover, the formula allows for the fact that the propulsion efficiency remains constant over the entire speed range. Finally, it includes the proportional dependence of drag on $D^{2/3}$; in similar submarines, this area is proportional to the hull surface exposed to friction. Consequently, the nondimensional coefficient C includes the drag coefficient for the hull and the propulsion efficiency.

True submarines with large superstructures, broad-beamed decks, guns, etc. may have C values as low as 60 during submerged cruising, but modern submersibles can have C values of 280 and higher. As a result of better configuration, smaller appendages, and higher propulsion efficiency, modern submersibles can make the same speed with one-fourth to one-fifth of the submerged engine power.

CHAPTER VII

STEEL STRUCTURES

LOADING DUE TO WATER PRESSURE

Diving depth is an important design criterion. The pressure hull is the primary element of a submarine and must withstand diving pressure. It is designed for a certain collapse depth, and the danger of failure must be confined within narrow limits. The other members exposed to water pressure, such as hatches, valves, torpedo tubes, and pressure-resistant lines in the outer hull, require a higher critical pressure.

A submarine must never approach the design collapse depth. It must go no deeper than the nominal diving depth, which is coupled to the collapse depth by a safety factor.

This safety factor amounted to 2.5 in the former German Navy and to 1.5 in the U. S. Navy. Other navies use safety factors between these values. When high safety factors such as 2.5 are used, a submarine can exceed the nominal diving depth (which is the maximum depth for emergency operations) by a greater amount than can a submarine with a smaller safety factor.

Germany's World War II submarines were designed for a collapse depth of 250 m; this corresponded to a safety factor of 2.5 and a nominal diving depth of 100 m. However, when under enemy attack, they frequently went to between 150 and 180 m without incurring damage.

Occasionally these submarines dove even deeper, sometimes denting their hulls. It will never be known how many submarines were lost by diving to such unacceptably large depths.

SHOCK LOADS

In addition to the diving pressure, the submarine has to withstand loads generated by nearby underwater detonations. An underwater detonation generates a momentary pressure wave followed by a gas bubble vibration. The pressure wave strikes first, and as its impact is diminishing, there is an enforced vibration caused by the gas bubble that arrives slightly later. Moreover, the superimposed vibrations acting on the pressure hull can also cause suction effects.

The effect of an underwater detonation is greatest when it occurs under the submarine. In decreasing order of importance, other effects are from detonations at either side, from ahead or behind, and from above. Direct underwater hits will always destroy the submarine.

Detonations at the water surface, e.g., detonating shells, have practically no effect on submerged submarines.

OTHER LOADS

Like any other ship, a submarine on the surface is subject to longitudinal and transverse loads as well as to torsion caused by seaways. In addition, there are local loads caused by wave impacts and individual loads, such as those originated by the engines. The thrust of the thrust bearing must also be absorbed. Transverse loads develop in drydock.

STRENGTH OF THE PRESSURE HULL

As a rule, the middle section of pressure hulls are cylindrical and end in conical closures fore and aft. These are sealed off by the end bulkheads. The cross sections of such pressure hulls are circular throughout.

The pressure hull is stressed by the water pressure, and the effect is opposite to that of a boiler under internal pressure. The pressure hull is subjected to compressive stress rather than to the tensile stress of a boiler.

The longitudinal stress at the boiler is one-half the magnitude of the circumferential stress.

This circumferential stress is

$$\sigma = \frac{p \times R}{\delta}$$

where σ is the stress in kips/centimeter²,
p is the pressure (excess atmospheres),
R is the radius in centimeters, and
 δ is the plate thickness in centimeters.

It is the function of the pressure hull shell to form a pressure-resistant space and to absorb the forces resulting from the external pressure.

The shell can absorb forces in the longitudinal direction without the need for additional stiffeners. However, the transverse frames are required to absorb circumferential forces because of buckling loads. These frames are welded to the shell and act as one unit. Frame stiffness (the moment of inertia) is increased by the load-carrying members of the shell, and the load of the shell is reduced by the load-carrying cross-sectional area of the frame.

A cylinder with transverse stiffeners exposed to external pressure can be destroyed in any one of three ways (see Figures 13-15).

The first type of failure is encountered when the shell is loaded beyond the yield point above the frames or in the middle of the frames. Here the shell will yield over its entire circumference between the frames. The prerequisite for this type of destruction is closely spaced frames that can withstand the load.

In the second type of failure, the shell buckles in a checkerboard pattern between frames. One buckle will be directed inward and the other one outward. The water pressure suppresses the outward buckles as deformation continues. The prerequisite for this type of destruction is widely spaced frames that can withstand the load.

In the third type of failure, the entire pressure hull (that is the shell and frames) buckle over the entire length. If transverse bulkheads or web frames are installed, the buckling process takes place between them. The prerequisite for this type of destruction is frames with an inadequate load-bearing capacity.

Optimum utilization of the material, that is, the lightest pressure hull for a given collapse pressure, could be achieved if all three types of failure started at the same pressure. However, Types 2 and 3 (Figures 14 and 15) cannot be calculated with the same accuracy as Type 1 (Figure 13); moreover, an increase in the collapse pressure for Types 2 and 3 will require much less hull weight than the same objective under Type 1. The magnitude of the collapse pressure, therefore, is staggered by a small amount in 1, 2, 3 order. A pressure hull constructed on this principle

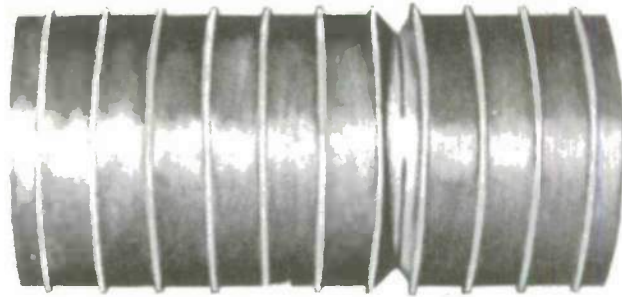

Figure 13 - Yielding of Shell between Frames

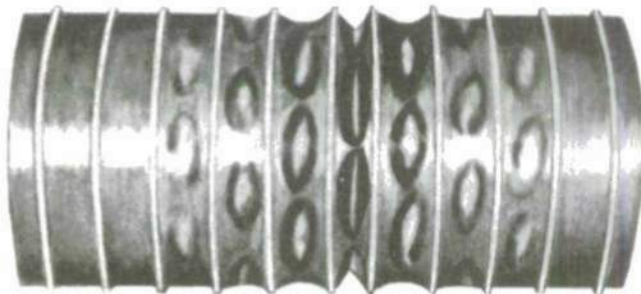

Figure 14 - Shell Buckling between Frames

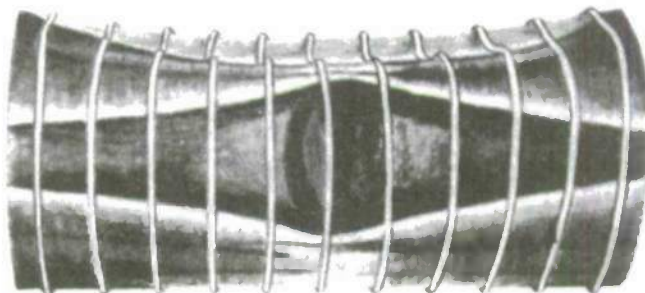

Figure 15 - Complete Collapse of a Pressure Hull

begins to fail with a shrinkage of the shell between frames. Swellings will then form between the frames, followed by complete collapse, generally between the bulkheads.

Since the forces that act on a pressure hull at maximum diving depth are extremely large, it is not surprising that the problems associated with longitudinal and transverse strength in a seaway, docking strength, and absorption of individual loads (such as arrangement of the main engines) play no part when the dimensions are being selected.

A 5-m-diameter pressure hull at a depth of 200 m will be exposed to a load of 1000 metric tons per meter of hull length.

From the viewpoint of the buckling of pressure hull frames, it makes no difference whether internal or external frames are used. More favorable space conditions inside the pressure hull result when the use of external frames is possible but only when outer space is available (double-hull submersible). External frames have about 5 percent more load-carrying capacity than internal frames of the same size because external frames are drawn into the plane of the frame due to the tipping of the profile that is connected with buckling whereas the internal frames deflect off this plane. There is no difficulty in welding the external frames to the hull solidly enough to eliminate the danger of premature separation. Stress concentrations develop at the transition points between the cylindrical and conical parts of the pressure hull. These can be reduced by welding reinforcing bars to the hull. Furthermore, rigid transverse bulkheads at the junction points can cause greater stresses in the pressure hull shell. One way to counter this is to reduce the frame spacing next to the transverse bulkheads.

Up to the end of World War II, Germany used a carbon steel (St 52) with good welding characteristics, a yield point of 3600 kip/cm², and a strength of 5200 kip/cm². A more recent trend is toward steels with higher yield points (5600 kip/cm² and higher).

Steels with great elongation and notch impact resistance are preferred because of blast strength requirements. (In most instances, the frames are manufactured of rolled T-profiles or from plates that are welded together. Ordinary bulb profiles are sometimes used also.)

All areas in the pressure hull that are weakened by openings such as hatches, shaft exits, exhaust ducts, ship valves, etc., are carefully

compensated for by reinforcements. Shell reinforcements are designed in the form of reinforced plating welded to the shell. Interrupted frames are replaced by additional, subsidiary frames.

The curved, basket-shaped end closures are frequently made of cast steel (Figure 16). The supports for the torpedo tubes are cast to the end closures. However, when flanged end closures are used, the supports are welded to the closures. Plane end closures with horizontal or vertical stiffeners are used instead of the curved end closures (Figure 17).

Hatch covers are made of cast steel. They open outward and so are sealed by the water pressure (see Figure 56 in Chapter XI).

The heavier construction of the pressure hull enables it to absorb individual loads easier than could the hulls of other combatant ships.

A pressure hull built for great depths is more resistant to shock loads than one built for shallow depths. Concentrations of material are a disadvantage when exposed to shock loads; therefore care should be taken to distribute the material as evenly as possible.

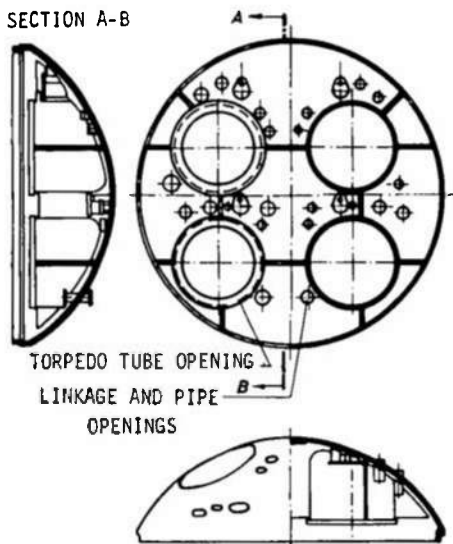

Figure 16 - Pressure Hull End Closure Bulkheads of Cast Steel

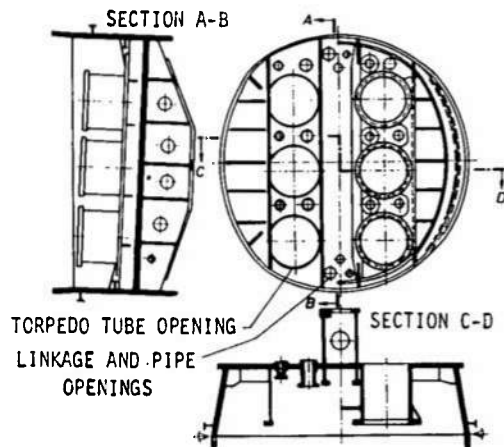

Figure 17 - Pressure Hull End Closure Bulkhead of Flat Welded Design

PRESSURE-RESISTANT CONNING TOWER

Many submarines have a pressure-resistant conning tower amidships on top of the pressure hull which accommodates an observation post for the periscopes. The conning tower hatch is located in the top of the conning tower. The control room hatch is located between the pressure hull and the conning tower. As a rule, the width of the conning tower must be considerably less than its length because of the water drag caused by the conning tower superstructure.

Because an elliptical conning tower (Figure 18) deviates considerably from a circular configuration, large bending moments will develop in its vertical wall; thus very thick materials are required for the bulkheads as well as for the conning tower roof. German submarines used armor steel for these conning towers in order to provide some protection against gunfire shells during surface actions. The wall thickness was much greater than that of the pressure hull. At the same time this provided the strength required to withstand the water pressure during diving.

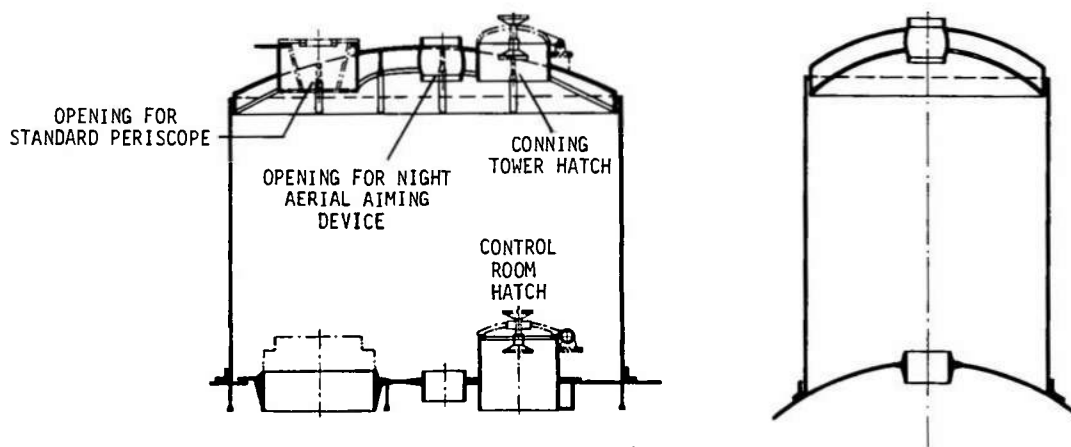

Figure 18 - Elliptical Conning Tower (German Boats, 1935-45)

Conning towers built of two cylindrical shells (Figure 19) are lighter than elliptical towers because the static strength relationships are simpler. These conning towers are suitable for small submarines.

Conning towers designed as horizontal cylinders (Figure 20) are used for large submarines. They are built as independent pressure tanks and are connected to the pressure hull by trunks. Adequate connections must be installed between conning tower and pressure hull to provide resistance against shock.

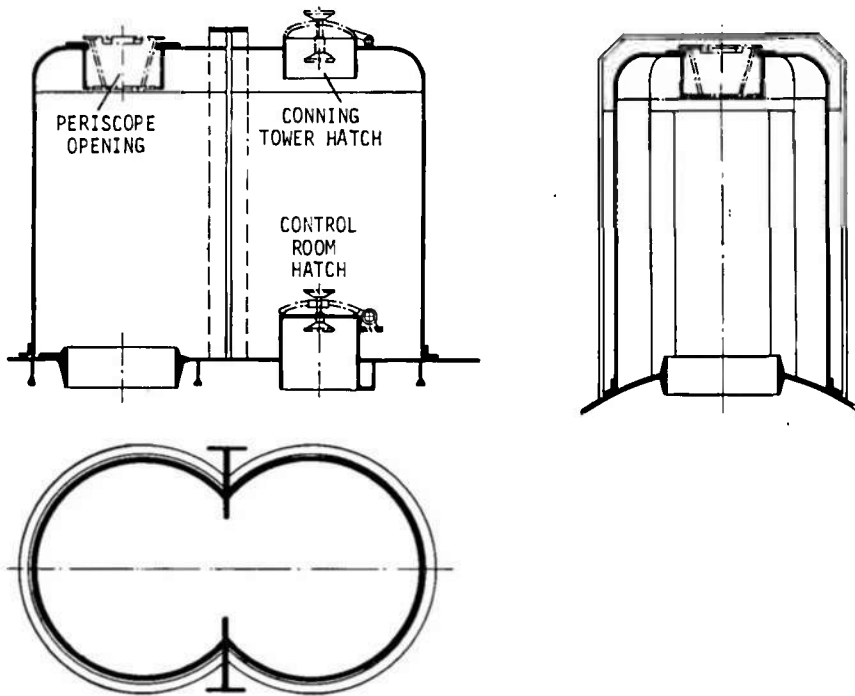

Figure 19 - Conning Tower of Two Cylindrical Shells

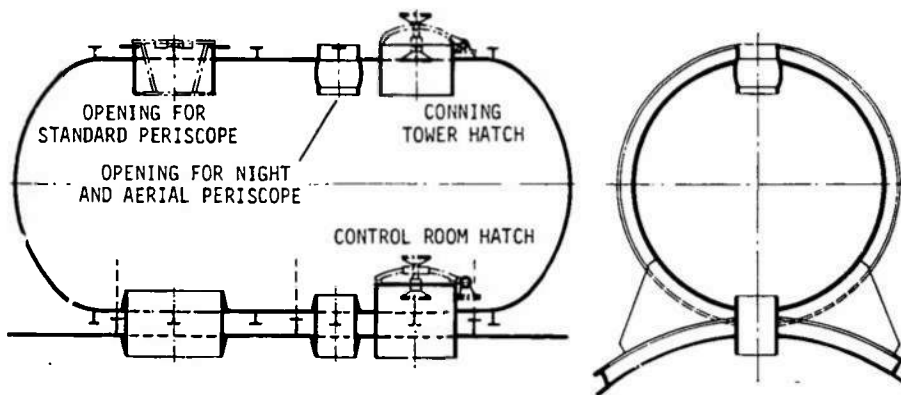

Figure 20 - Conning Tower Constructed as a Horizontal Cylinder

STRENGTH OF OTHER STRUCTURAL MEMBERS

↙ The outer hull, which is not exposed to water pressure, as well as the structural members inside the pressure hull are designed for minimum weight. The outer hull and the free-flooding superstructure must be able to withstand wave impacts and additionally, the ballast tanks must withstand the static internal pressure. ↘ The internal tanks and compartments must be able to withstand the predetermined operating pressure by a large margin of safety. Underwater detonations will have little effect on the flooded outer hull and so do not affect its construction. However, the internal members must be able to withstand shock loads transferred to them by the enclosed pressure hull, and they should be so dimensioned that they collapse later than the pressure hull. Lightweight members may be designed in several different ways: narrow-spaced stiffeners that result in thin plates; frequent support of pressure hull stiffeners that result in light stiffeners; and use of high-strength steels, sea-water-resistant aluminum alloys, and plastics.

CHAPTER VIII

ARMAMENT

Most submarines are used as weapon carriers. The emphasis here is on undersea weapons since missile armament will not be discussed. Submarines are especially well suited as carriers for weapons such as torpedoes and mines that damage enemy ships below the waterline. Guns to engage surface and air targets have always been secondary weapons.

TORPEDO ARMAMENT

The conventional armament is a target-aiming torpedo with a length of about 7 m, a diameter of 53 cm, and a maximum weight of about 1.9 metric tons, which is trimmed for a static negative buoyancy of up to 0.5 metric ton. (This means that the displacement of the torpedo is 0.5 metric ton less than its weight.)

There are torpedoes of smaller dimensions that are developed as submarine chasers.

Torpedo Tubes

Torpedoes are carried in torpedo tubes and spare torpedoes are usually carried as reloads.

The discussion will consider torpedo tubes whose aft part is enclosed by the pressure hull. Torpedo tubes are sometimes fixed and sometimes swivel-mounted on the free-flooding upper deck outside of the pressure hull.

The torpedo tube is a pressure-resistant structure that has a muzzle cover forward and a breech aft (Figures 21 and 22). About two-thirds of the tube is located outside the pressure hull and one-third inside. The part outside the pressure hull is exposed to external pressure and is provided with external frames to absorb the buckling loads. The part inside the boat is stressed by the water pressure from inside when the muzzle cover is open. The muzzle cover opens outward against the water pressure. Profiled rubber gaskets are used as seals. The cover is actuated from inside the submarine by spindles and linkages that are operated manually or hydraulically. A faired lightweight cover is located in the free-flooding

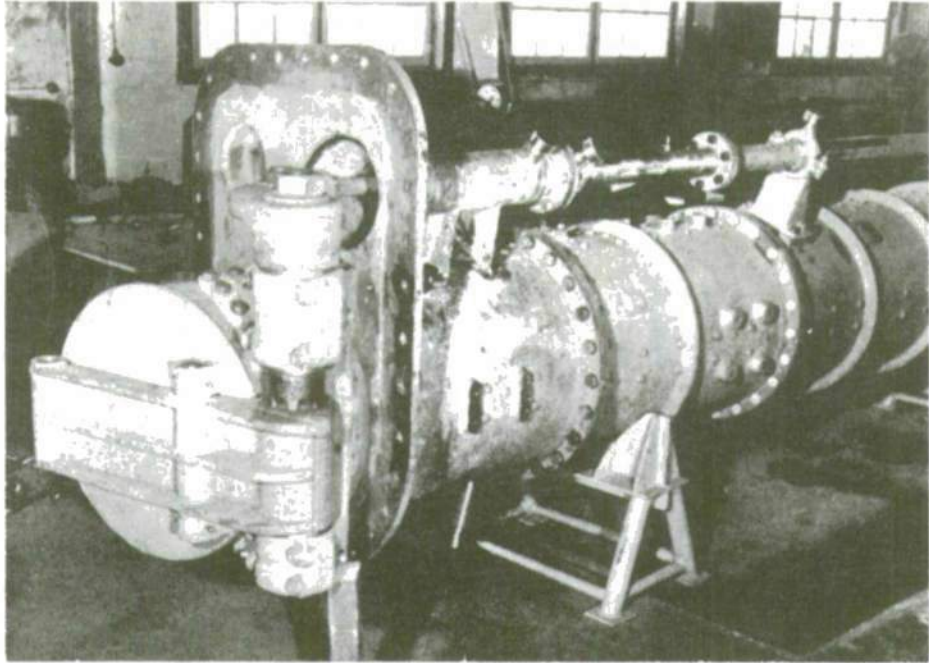

Figure 21 - Torpedo Tube, Forward View

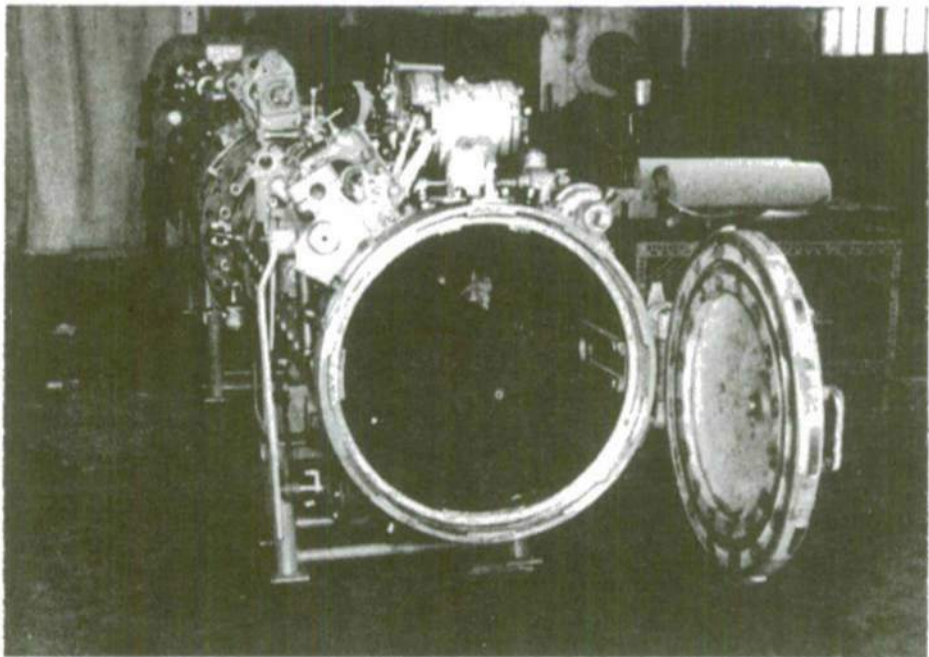

Figure 22 - Torpedo Tube, Aft View

part of the hull because the muzzle cover is not adapted to the shape of hull. This faired cover is linked to the muzzle cover. The fairing results in a smooth outer hull in the area of the torpedo firing path.

The breech door is manually operated; it opens into the interior of the submarine and is provided with a catch-ring closing device sealed by a profiled rubber gasket. The breech door and muzzle cover are interlocked so that only one of the covers can be opened at any one time.

With few exceptions, the torpedo is breech-loaded and stored dry in the tube. Prior to firing, the tube is flooded from the torpedo cell inside the submarine; the torpedo is surrounded with water so that the weight of the submarine will remain unchanged. However, there will be a change in trim unless the center of gravity of the torpedo tank is located below the center of gravity of the enveloping water in the torpedo tube. When the pressure between tube and sea water has equalized, the muzzle cover is opened along with the faired cover. The torpedo is now ready for firing. After the firing, the submarine is no longer affected by its negative buoyancy because sea water replaces the torpedo in the tube. The lack of negative buoyancy must be compensated for immediately in order to maintain depth control; this is accomplished by flooding the torpedo tank. When the tube is reloaded after a firing, the muzzle cover must be closed and the tube drained into the torpedo tank. The breech door is then opened and a spare torpedo inserted.

Torpedo tubes have the necessary fittings for setting the torpedo running depth, firing angle, etc. prior to a firing. Some of these fittings are remotely controlled by the fire-control system. Modern torpedo tube design requires the torpedo to be fired at any admissible depth without generating an air bubble that could betray the submarine.

Torpedo Discharge Principle

The torpedo is discharged at a speed of about 10 m/sec. The torpedo is accelerated to its terminal velocity by its own engine.

Up to the end of World War I, torpedoes were directly ejected by compressed air, and an air swell rose to the surface and could betray the location of the firing submarine.

A piston-type torpedo tube (Figure 23) in which the torpedo was separated from the ejecting compressed air by a piston was standard equipment for German submarines in World War II.

After the torpedo is fired, the piston is pressed back by sea water. The compressed air behind the piston vents into the submarine. This design will not generate an air bubble. There are depth firing limitations (as was the case in World War I as well). The tubes must be manufactured with great accuracy to guide the piston; they are heavy and relatively expensive.

A pistonless air ejection system that does not generate an air bubbled was developed abroad and installed in several types of submarines including the German Type 21. The torpedo rests in guide rails in a tube of greater diameter. The tube and its torpedo caliber are watertight only at the muzzle. The ejection air is adjusted so that its pressure is slightly less than the external water pressure at the moment the torpedo leaves the caliber near the muzzle. At the same time, there is automatic opening of a vent valve located at the aft end of the tube and leading into the inner boat. As soon as the torpedo has left the tube, sea water fills the tube and pushes the ejected air into the interior of the submarine through the vent valve. The valve closes again when the water needed to compensate for the negative buoyancy of the torpedo has entered. This discharge method is almost free of air swells, but firing depth limitations are imposed by the design. The tube is relatively light in weight and cheap to manufacture.

Some ejection tubes discharge torpedoes by means of water that is pressurized in special chambers by compressed air. These tubes produce no air swells, and ejection is possible at any depth. This system is heavier than the compressed air system.

Other types of tubes can eject torpedoes mechanically with cables. These tubes are larger in diameter than their torpedo calibers and can be fired at great depths without causing air swells.

Torpedo Launching Principle

Launching tubes are used in addition to ejection tubes. Here the torpedo is accelerated in the tube and leaves the tube under its own power. The torpedo is guided by rails installed in the wide tube. Launching tubes do not generate air swells. They are light in weight and are cheap and

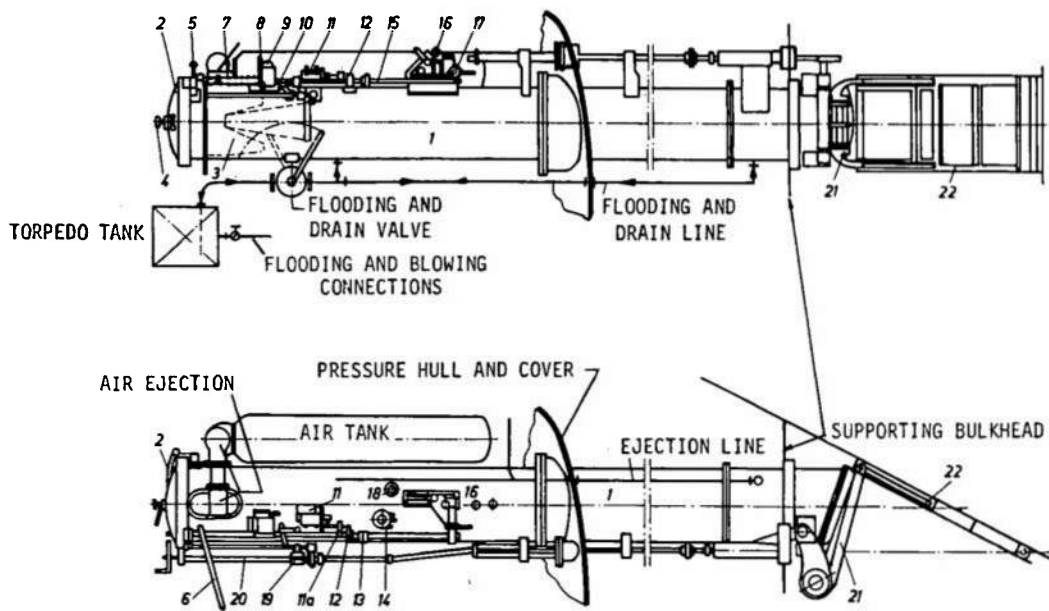

- | | | | |
|-----|-----------------------------------|----|--|
| 1 | TORPEDO TUBE | 12 | LINKAGE STOP |
| 2 | BREECH COVER | 13 | RUBBER BUFFER |
| 3 | EJECTING PISTON | 14 | RUNNING CONTROL MECHANISM FOR STRAIGHT AHEAD RUN |
| 4 | TORPEDO SUPPORT | 15 | CONNECTING ROD |
| 5 | HAND FIRING LEVER | 16 | TORPEDO RETAINING AND OPENING BOLT |
| 6 | TENSION LEVER | 17 | CONVERTER FROM TORPEDOES TO MINES |
| 7 | RELEASE SPRING | 18 | DEPTH CONTROL MECHANISM |
| 8 | READY BOLT | 19 | DOG FOR ENGAGING LOCKING BAR |
| 9 | ELECTROMAGNETIC RELEASE MECHANISM | 20 | MUZZLE COVER OPERATING MECHANISM |
| 10 | RELEASE ROD | 21 | MUZZLE COVER |
| 11 | RELEASE VALVE | 22 | FAIRED COVER |
| 11a | ENGAGING DOG FOR RELEASE VALVE | | |

Figure 23 - Piston-Type Torpedo Tube

simple to manufacture. One disadvantage is that the greater quantity of enveloping water requires a larger tube diameter and thus larger torpedo tanks are required.

For midget submarines of very simple design, the launching tubes can be replaced by launching racks from which the torpedoes are suspended alongside the boat. The launching method is the same as that used for launching tubes, namely, by starting the torpedo engines. The disadvantages of this simple and cheap design are that (1) submarine drag is increased quite considerably by the exposed torpedo, (2) the torpedo cannot be serviced while underway, and (3) it is exposed to water pressure and the corrosive effect of sea water.

Torpedoes launched under their own power leave at a slower speed than ejected torpedoes.

Torpedo Tanks (WRT)

The size of the torpedo tank required for each torpedo firing system depends on the number of torpedo tubes to be flooded, the number of spare torpedoes carried, and the volume of the enveloping water required for each torpedo tube.

The volume required for a torpedo tank is determined by

$$V = n \times H + r \times G$$

where n is the number of torpedo tubes to be flooded simultaneously,

H is the enveloping water per tube,

r is the number of spare torpedoes, and

G is the weight of one spare torpedo.

Water is blown from the torpedo tank to the tubes and back by means of low-pressure air. The size of the torpedo tank is designed to correspond to the applied pressure. The water pipes between each tube and the torpedo are provided with stop valves. These are interlocked with their associated muzzle covers so that the torpedo tanks cannot be flooded from the tubes when the muzzle covers are open. The torpedo tanks are connected to the submarine bilge and ballast system; they have special flood ducts to admit water to compensate for the negative buoyancy during firing unless this is done through the torpedo tubes.

Torpedo Loading System and Torpedo Storage

Torpedoes are generally loaded into the submarine through a torpedo hatch that is located above the torpedo compartment and penetrates the pressure hull at an angle (Figure 24). The torpedo hatch design resembles that of an access hatch (see Figure 56 in Chapter XI). Foreign navies frequently use an additional internal torpedo hatch for safety reasons (dual-hatch principle). Inclined troughs with wooden liners are installed on the upper deck and in the torpedo room compartment before the torpedoes are loaded. The torpedo is loaded from the pier onto the trough on the upper deck and then lowered away by a wire and winch or capstan arrangement. Once inside the submarine, the torpedo is grasped by a hoisting device and positioned horizontally. It is then positioned in front of the tube by lowering and lateral shifting, and is finally moved into the tube by toothed rack and pinion devices or tackles.

Spare torpedoes are stored in troughs and are secured in the compartment behind the tubes. In large submarines, one set of spare torpedoes can be placed in a rapid reloading position immediately behind the tubes.

Small, simple submarines may not have adequate space for a torpedo hatch and a torpedo reloading compartment behind the tubes. In such cases, the torpedoes are loaded from the outside (muzzle-loading principle). It must be possible to trim the boat by the stern so that the muzzles are above the waterline. Troughs are suspended in front of the tubes and the torpedoes are set in them for reloading.

Arrangement of Torpedo Armament

A distinction is made between bow, stern, athwartship, and topside torpedo tubes. Bow tubes are flanged to the forward end closure bulkhead as a unit. Their forward ends are supported by the torpedo tube supporting bulkhead (Figures 21 and 22). The space between this bulkhead and the pressure hull is often used as a ballast tank. The bow unit can consist of two to eight torpedo tubes.

A similar configuration is used at the stern. Here the tubes are placed above the propellers and rudders. One to four tubes can be accommodated in the stern. If storage areas are used for spare torpedoes for the

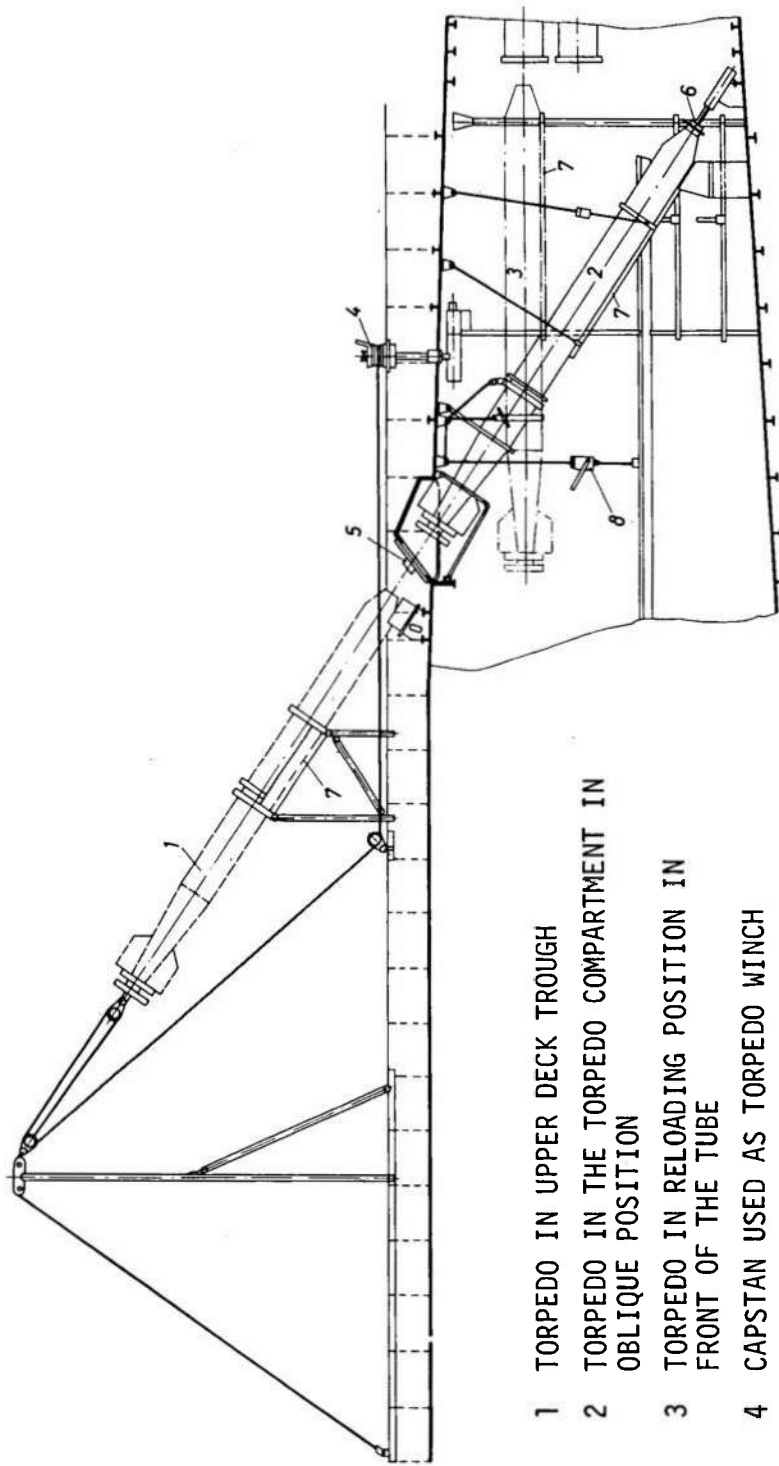

- 1 TORPEDO IN UPPER DECK TROUGH
- 2 TORPEDO IN THE TORPEDO COMPARTMENT IN OBLIQUE POSITION
- 3 TORPEDO IN RELOADING POSITION IN FRONT OF THE TUBE
- 4 CAPSTAN USED AS TORPEDO WINCH
- 5 STOPPER ON THE TORPEDO HATCH
- 6 STOPPER IN THE TORPEDO COMPARTMENT
- 7 TORPEDO TROUGH
- 8 HOISTING GEAR TO LOWER TORPEDOES

Figure 24 - Torpedo Loading System

bow and stern tubes, they are also located aft of the forward tubes. Athwartship torpedo tube units had been planned for the German World War II Type 26 submarine (this type was not completed and was dismantled after the war); see Figure 9 and the Appendix. This configuration provided for a common torpedo loading room for the bow and athwartship batteries.

Upper deck torpedo tubes are no longer used for modern submarines because of their very small free-flooding superstructures. They have been used on true submarines in the form of fixed, single stern tubes and pivoting multiple mounts in the amidships area. Torpedoes located in upper deck tubes cannot be serviced underway.

WEAPON CONTROL SYSTEMS

All submarines have weapon control systems to automatically calculate and remotely control firing data (lead angles, etc.) for the torpedo armament. The circuitry is designed so that tubes can be combined into units to fire multiple shots at different targets or spreads at a single target.

Weapon control systems are installed in the vicinity of the detection systems. In submerged action, information on the enemy is fed into the weapon control systems from the periscope, sonar, and listening device or from a radar that extends above the surface. In surface action, these data are acquired by an optical target-tracking instrument on the bridge and by radar. Own course and speed are additional inputs.

MINE ARMAMENT

Submarines can be employed as offensive minelayers. They are not so easily observed as a surface ship or mine-carrying aircraft while approaching a minelaying area, while laying mines, and while departing from the area.

Torpedo-type submarines can load ground mines or anchor chain mines in place of torpedoes, loading; three bottom mines or two anchored mines can be carried in one torpedo tube. Consequently, a submarine can load three times as many ground mines or twice as many anchor chain mines as it can torpedoes. One such mine load weighs more than a torpedo load.

To compensate for this weight difference, a smaller envelope of water is carried in the torpedo tank because it is not necessary to flood as many tubes simultaneously during a mining operation as during a torpedo attack. Mines are usually ejected by compressed air.

When submarines are built specifically as minlayers, mines are accommodated in vertical shafts. Each shaft can hold several mines, one on top of the other. The shafts are either installed at the side in the outer hull where they are not pressure resistant or they pass through the pressure hull. In either case, because the mines are exposed to the diving pressure and cannot be serviced, a special mine design is needed. During the minelaying operation, the mines are released from the shaft in sequence and sink as a result of their negative buoyancy. Special mine compensation tanks are required.

GUNNERY

As late as World War II, most submarines carried guns on deck for surface engagements. These guns were long-barreled with calibers up to 12 cm and were either exposed on deck or their shields were part of the envelope of the conning tower. They were supplied with ammunition from inside the submarine through the conning tower hatch. Ready ammunition was stored in pressure-resistant lockers near the guns. In addition, AA guns up to 3.7 cm caliber were installed on the bridge. These, too, were exposed to sea water during submerged cruising. Special fire-control systems were generally nonexistent. Guns are no longer installed.

CHAPTER IX

METHODS FOR DETECTION, WARNING, AND DECEPTION

DETECTION SYSTEMS

These are defined as any systems used to detect the enemy. Some of the information acquired by these systems is fed directly to the weapon control system for processing.

Radar Systems

Submarines can use radar systems at periscope depth when surfaced and submerged. The antenna must be above the surface because radar waves will not propagate in water. Therefore the radar mast is extendable, and the rotating antenna is pressure-resistant. The mast is extended and retracted hydraulically by pistons or mechanically by cables and winches. The rotating device of the antenna can be operated hydraulically or electrically. The retracted antenna is housed within the free-flooding superstructure. The radar operating device is located in the submarine detection room.

Ships, shore elevations, and aircraft can be detected by this radar system within the limits of the horizon. The data measured by a fire-control radar can be used for torpedo firing. Since the radar is an active source of radiation, there is danger that the submarine will betray its position to the enemy before it can acquire the information it needs.

Sonar Systems

Sonar can be used to acoustically detect ships as well as submerged and surfaced submarines. Sonar operates on a principle similar to that of radar; its ranges are shorter and greatly dependent on the "acoustical weather" of the water. This weather is affected considerably by salinity, water temperature, depth, water layers, waves, and many other factors. Sonar range is shorter in the Baltic than in the Atlantic, shorter in the daytime than at night, and shorter in the summer than in the winter. A rotating sonar transducer base is located outside the hull to emit sound and to receive echoes over a maximum sweep angle (Figure 25). Preferred

locations are the upper deck or the bottom of the keel at the bow area because the sonar should be as far removed as possible from noise sources of the boat itself (primarily the propellers and the secondary propulsion plant). The sonar operating device is located in the sonar room.

The dome base must be pressure-resistant and can have an area 1 by 1 m. The rotational drive is from inside the pressure hull or from a special pressure-resistant casing. The base must be surrounded by a housing to eliminate the interference caused by water noise. The hydrodynamic configuration of this housing is selected with special care (Figure 26). Its supporting structure may consist of round steel bars in diagonal patterns that will not generate shadows. The fairing placed on top of this framework is made of thin sheet steel permeable to sound waves. Several countries are experimenting with sonar domes of polyester or other plastics.

Sound radiation can betray a submarine before it is able to acquire the information it needs. Therefore, sonar is employed for short intervals only. Its primary use is the acquisition of fire-control data just before a torpedo is fired.

Sound Detection

Passive underwater listening equipment is the most important detection system in any submarine. Its range depends on the strength of the noise source to be detected and, as in the case of sonar, on the "acoustical weather."

Cluster-type listening devices combine many sensors which are arranged in horseshoe fashion in a bulb at the bow (Figure 27). The sensitivity and accuracy of the information obtained on target bearing depends, among other factors, on the number and sensitivity of the individual receivers and on the dimensions of the group (for instance, 2 m wide by 4 m long). Oscillators are installed a short distance behind a thin steel plate which is flush with the outer skin. This eliminates local hydraulic noise in a manner similar to that used with the sonar dome. Systems have been built that include more than 100 oscillators. The operating device is installed in the detection room. The submarine listens continuously when underway by using several specific detection devices. In addition to the group detection system, the sonar receiver can be used for passive listening.

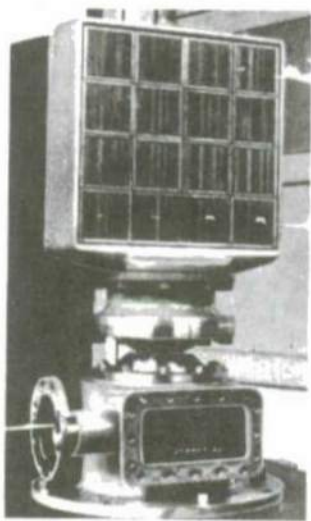

Figure 25 - Transducer of a Sonar System

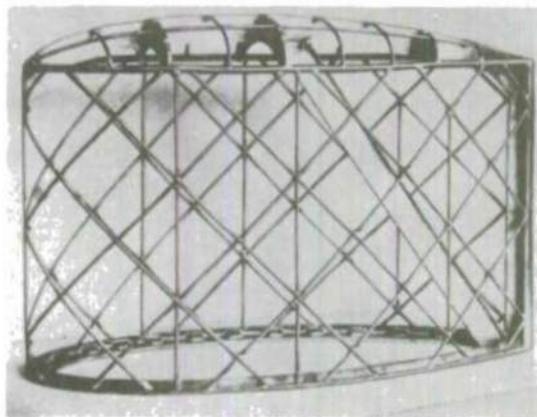

Figure 26 - Supporting Structure for a Sonar Dome

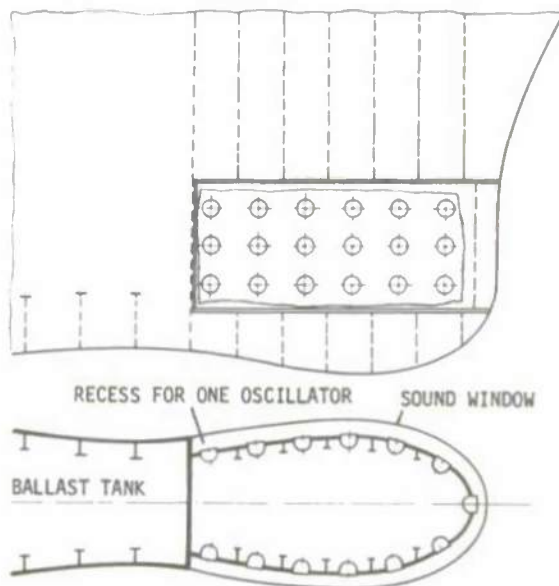

Figure 27 - Balcony Configuration of Receivers

The listening range of sonars on the high seas can be very great. Ship concentrations have been located at ranges of 50 nm. Unlike sonar, listening with the group detection system does not permit direct ranging.

WARNING SYSTEMS

The objective of these systems is to detect the operation of enemy detection systems early enough for the submarine to take countermeasures.

Radar Warning System

A submarine can be detected by enemy radar while cruising on the surface or even when submerged and running on snorkel. Early warning radar is provided to detect oncoming radar radiation as early as possible. The pressure-resistant antenna of this device is installed on an extensible mast or on top of the snorkel mast so that they can be extended when the submarine is running at periscope depth. The associated control device is usually installed in the detection room.

Sonar Warning System

When a submarine is running submerged, its warning sonar device detects oncoming enemy sonar waves. Warning sonar operates on a principle similar to that used for listening. The receivers are placed to pick up sonar pulses arriving from any direction.

Deception Methods

These are defined as any measure taken by, or equipment installed in, the submarine that will make it difficult for the enemy to detect the submarine and to employ his weapons with precision.

There was a time when a submerged submarine was considered to be completely concealed from the enemy unless the periscope betrayed its location. Later, aircraft placed a limit on submerged submarine concealment. Aircraft can detect submerged submarines at considerable depth in clear water when lighting conditions are favorable and when the sighting angle is steep. Concealment against this type of detection is accomplished by painting the topside of the boat dark grey to black.

Today, submerged submarines can be hunted and detected by the detecting equipment employed by ships and aircraft. Submerged detecting equipment does not have the range attainable by the optical equipment--or even by the radar equipment--used for surface detection. Nevertheless, enemy sonar and listening gear do make life difficult for the submarine..

A low silhouette with the smallest possible directly reflecting planes is an essential means of protecting the boat against sonar detection. Small submarines have the advantage. A low noise level will protect against their being heard.

Diving to greater depths can provide protection against sonar and detection devices, and so deep-diving submarines have an advantage.

A special rubber or plastic coating can be applied to the hull to prevent the reflection of sonar waves. During World War II, Germany developed a sheet rubber foil ("Alberich") that was perforated at predetermined intervals. The idea was to paste this foil onto the submarine to absorb incident sonar waves. Its effectiveness varied with temperature and depth. Because of the technological difficulties associated with the development of a suitable cement at that time, only a few submarines were equipped with the "Alberich" system.

A submerged submarine was able to take evasive action by ejecting into the water objects (code word "Bold") which remained suspended and generated gas bubbles to deceive the enemy. Their sonar reflections not only simulated a target for the enemy but also interfered with his listening gear. "Bold" was ejected from a 100-mm-diameter lock which had a muzzle cover and a breech cover similar to those on a torpedo tube (see Figure 28). "Bold" could be ejected mechanically by using either compressed air or pressurized water. In addition, signal devices could be ejected from the lock to rise to the surface.

The wake of a submerged submarine had an effect similar to that generated by "Bold." The wake of submerged submarines that continuously discharged CO₂ (submarines with the Walter propulsion system) provided excellent concealment and deception.

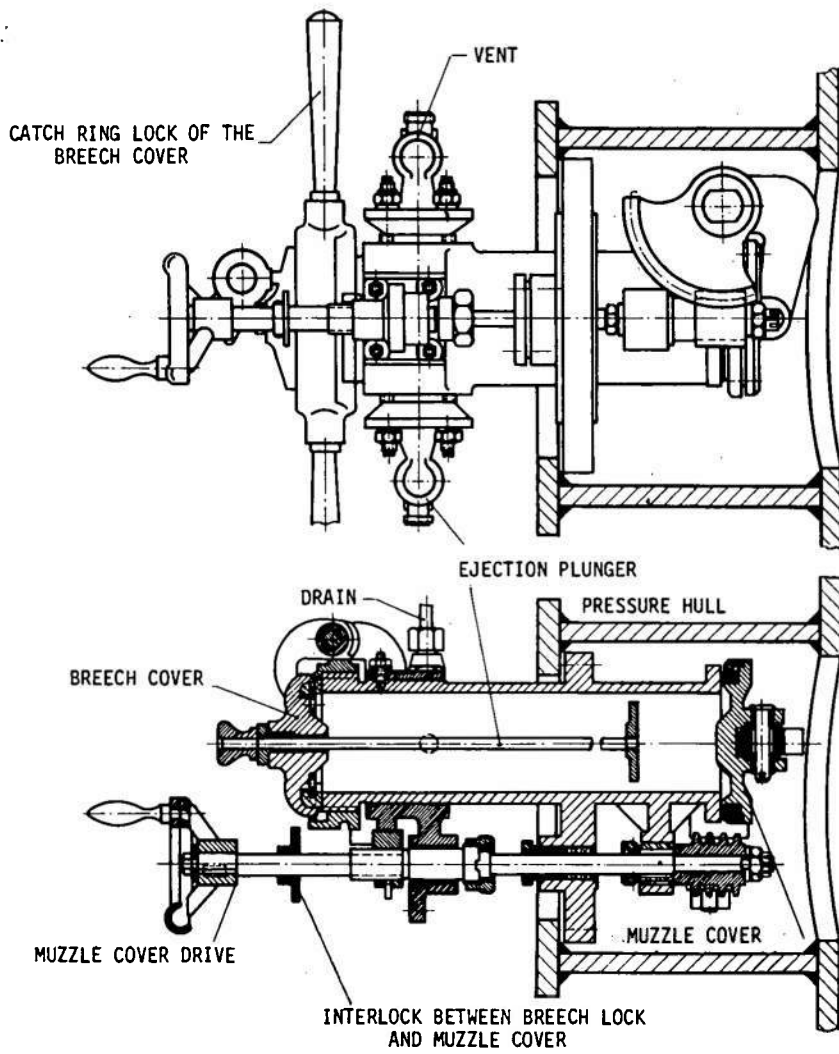

Figure 28 - Ejection Lock for "Bold"

CHAPTER X

PROPULSION PLANTS

PROPULSION PLANTS THAT USE LEAD BATTERIES, ELECTRIC DRIVE MOTORS, AND DIESEL ENGINES

The majority of submarines in service today are fitted with what is considered to be the conventional type of propulsion plant, namely, lead-acid storage batteries, electric-drive motors, and diesel engines that use snorkels. The batteries supply the electric-drive motors when the submarine is cruising submerged. When it is snorkeling, (a condition with limited diving readiness at periscope depth), the diesel engines charge batteries while the boat is driven by its electric motors. Diesel-electric propulsion is used on the surface while the batteries are used as buffer batteries or the batteries are charged by the diesels while the boat proceeds at reduced speed.

Some propulsion plants use the elements indicated above but have diesel engines that can be coupled directly to the propellers (Figure 29). This is done for surface and sometimes even for snorkel cruising. This system can be used primarily for "true submarines." Each shaft system consists of a diesel engine, a diesel engine clutch (disengaged when submerged), a main electric drive motor that alternates as a generator, a main clutch (disengaged only when batteries are recharged), a thrust bearing, and a propeller. There are two partial batteries of accumulators (this was the standard arrangement at the outbreak of World War II).

Several cruising methods are available:

1. Surfaced full-power running on both shafts. All clutches are engaged, both diesel engines are operating, and the electric-drive motors are running without load.
2. Surfaced cruising at slow speed on one diesel engine (port, for example). The port clutches are engaged, and the port diesel is running. The port electric motor operates as a generator, feeding the starboard electric motor while the battery is connected as a buffer battery. The starboard main clutch is engaged, the starboard diesel clutch is disengaged, and the starboard diesel engine is shut down. The port propeller revolutions are higher than those at starboard.

3. Surface cruising while batteries are charged from both electric engines. For the same configuration as described under Item 1, above, both electric engines are excited as generators (this is not possible at full rpm because the diesel engines must use some of their excess power to drive the generators).

4. Surfaced cruising on one diesel engine (port, for example) coupled to the propeller and charging with the other diesel motor. The port shaft is engaged as described under Item 1. The starboard main clutch is disengaged, and the starboard diesel clutch is engaged. The starboard diesel drives the starboard electric system, operating as a generator to charge the battery.

5. Surface charging when in port. Connections for both sides are as described under Item 4 for the starboard side. Both diesels are running, and both electric engines operate as generators to charge the batteries.

6. Submerged cruising on electric-drive motors. Both main clutches are engaged, diesel engine clutches are disengaged, the electric systems operate as drive motors, and the diesel engines are shut down.

7. The standard connection for snorkel cruising is that described under Item 4 which provides for maximum battery charging. Items 1 or 2 can also be used for cruising.

Figure 30 shows the propulsion plants for a single-shaft submersible in which the diesel engine can be coupled to the propeller. A main electric motor with reduction gear is used for submerged full-power propulsion. A special motor with cone belt reduction is used for noiseless, low-speed submerged cruising. This low-noise motor is also used for snorkel cruising when it is desired to charge the batteries at maximum power and rpm by using the diesel engine and the main electrical drive which is employed as a generator. There are also two separate batteries of accumulators. The battery is broken down into two groups (this arrangement was used for the small German Type 23, 1944).

The twin-shaft system shown in Figure 31 is a similar configuration except that the diesel engines and electric systems have separate reduction gears because of their different maximum rpm. Additional clutches are required. The two half batteries are each separated into three battery units (this arrangement was used in the large German Type 21, 1944).

- 1, 2 STARBOARD AND PORT DIESEL ENGINES
- 3, 4 STARBOARD AND PORT DIESEL CLUTCHES
- 5, 6 STARBOARD AND PORT MTDOR GENERATORS
- 7, 8 STARBOARD AND PORT MAIN CLUTCHES
- 9,10 STARBOARD AND PORT THRUST BEARINGS
- 11,12 STARBOARD AND PORT PROPELLERS
- 13,14 PARTIAL BATTERIES

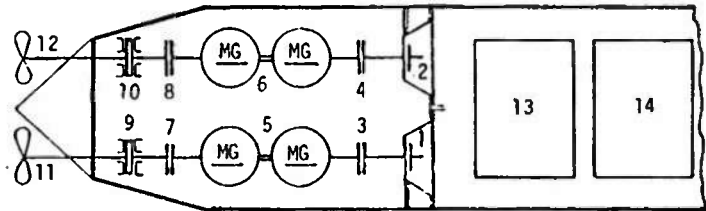

Figure 29 - A Twin-Shaft Installation with Direct Diesel Propulsion

- 1 DIESEL ENGINE
- 2 DIESEL CLUTCH
- 3 MTDOR-GENERATOR
- 4 GEARED TRANSMISSION
- 5 LOW-NOISE DRIVE MTDOR
- 6 CONE BELT TRANSMISSION
- 7 MAIN CLUTCH
- 8 LOW-NOISE CLUTCH
- 9 THRUST BEARING
- 10 PROPELLER
- 11,12 BATTERY UNITS

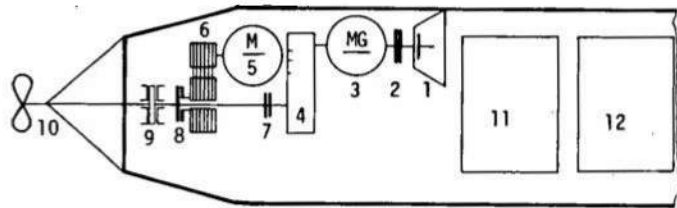
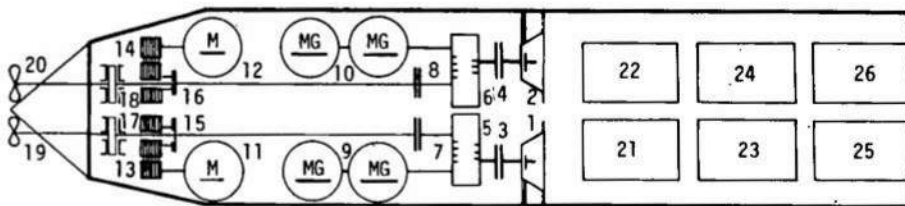

Figure 30 - A Single-Shaft System with Direct Diesel Drive and Separate Low-Noise Electric Drive



- | | |
|--|--|
| 1, 2 STARBOARD AND PORT DIESEL ENGINES | 13,14 STARBOARD AND PORT CONE BELT |
| 3, 4 STARBOARD AND PORT DIESEL ENGINES | 15,16 STARBOARD AND PORT LOW-NOISE CLUTCHES |
| 3, 4 STARBOARD AND PORT DIESEL CLUTCHES | 17,18 STARBOARD AND PORT THRUST BEARINGS |
| 5, 6 STARBOARD AND PORT TRANSMISSIONS | 19,20 STARBOARD AND PORT PROPELLERS |
| 7, 8 STARBOARD AND PORT MAIN CLUTCHES | 21,23,25 HALF BATTERY, CONSISTING OF THREE BATTERY UNITS |
| 9,10 STARBOARD AND PORT GENERATORS AND DUAL MOTORS | 22,24,26 HALF BATTERY, CONSISTING OF THREE BATTERY UNITS |
| 11,12 STARBOARD AND PORT LOW-NOISE DRIVE MOTORS | |

Figure 31 - A Twin-Shaft System with Direct Diesel Drive, Main Electric Drives with Separate Reduction Gears, and Separate Low-Noise Propulsion System

The arrangement of separate propulsion devices and generators shown in Figure 32 is well-suited for submersibles. The generators are coupled to the diesel engines and cannot be switched off. Cruising is always by diesel electric drive as long as the diesels are running. This system is very flexible in that the power of the diesel motors can be subdivided into loading and propulsion drive. Twin-shaft systems can be designed similarly. In addition, the drive motors can be subdivided into main drives and low-noise motors.

Lead Battery

The lead battery is used to store the electric energy required for the drive motors and for the board network use when needed in the submerged condition. Lead batteries are built on the grid-plate principle (see Figure 33) or (more recently) in a tubular design.

Voltage conditions are approximately the same for all lead elements whereas the capacity (stated in ampere-hours) and the electrical output (stated in kilowatt-hours) depend on the size and, to a lesser extent, on the internal structure of the element in question (see Figure 34). Lead cells have their greatest capacity when the discharge rate is slow. Their useful capacity will be greatly reduced when the discharge rate is fast, e.g., 0.5 to 1.5 hourly current. If a discharge starts with high current intensity, then a further capacity is available later for low intensity discharge. The kilowatt hours consumed will be approximately the same. The voltage available during discharge depends on the amount of discharge current and hence on discharge time (see Figure 35). The acid density decreases during the discharge.

The voltage used to charge a cell is higher than the discharge voltage (see Figure 36). Charging takes place in two steps: (1) the battery is charged at constant current and increasing voltage until a reading of 2.4 V is obtained and (2) the battery is charged at decreasing current and constant voltage until a minimum current has been reached. The ampere-hours needed for charging are approximately equal to the ampere-hours for discharge. The kilowatt-hour efficiency (i.e., the ratio of discharge to charge in kilowatt hours) of one cell ranges from 78 percent in the case

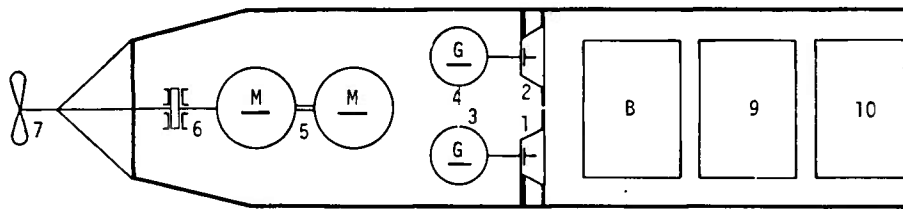

- 1,2 STARBOARD AND PORT DIESEL ENGINES
- 3,4 STARBOARD AND PORT GENERATORS
- 5 DUAL DRIVE MOTOR
- 6 THRUST BEARING
- 7 PROPELLER
- B-10 BATTERY UNITS

Figure 32 - A Single-Shaft System with Direct Electric Drive and Separate Diesel Generators

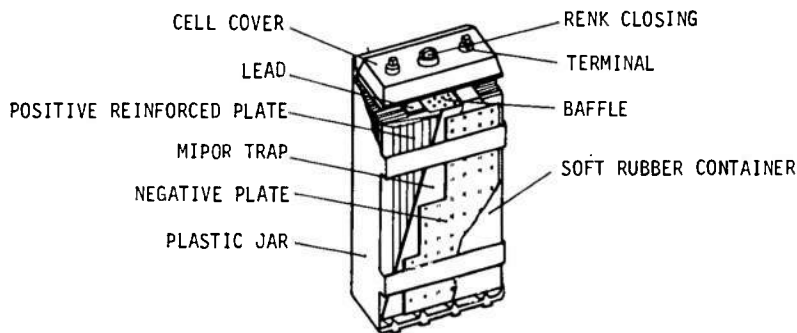

Figure 33 - Structure of a Grid-Plate Cell

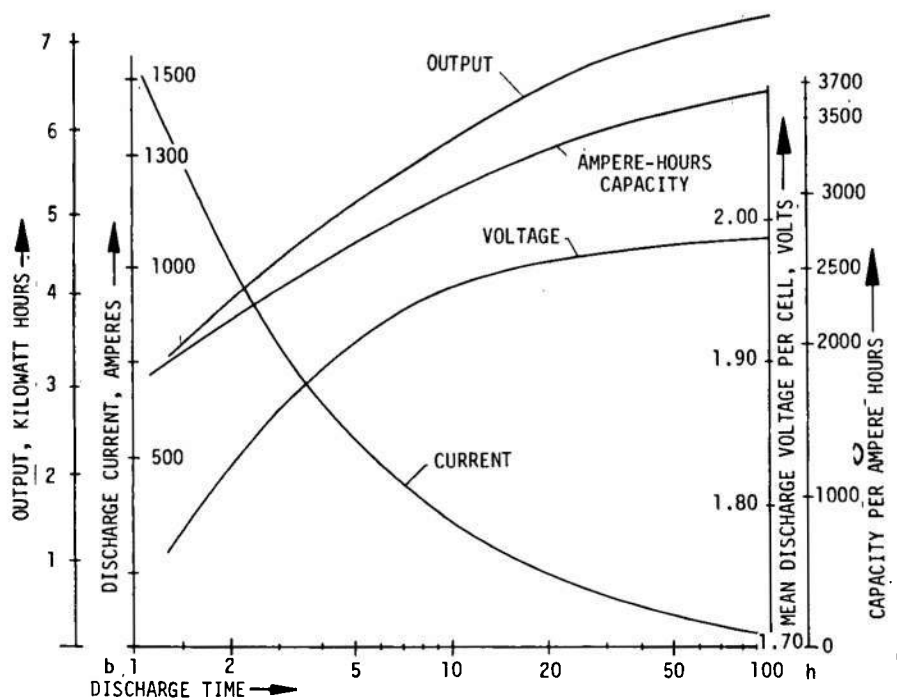

Figure 34 - Capacity Characteristics of a Lead-Acid Cell Battery

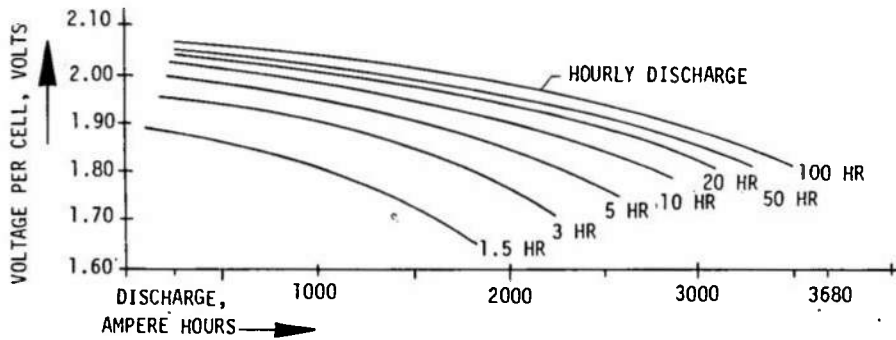

Figure 35 - Voltage Curves of a Lead Battery for Different Discharge Times

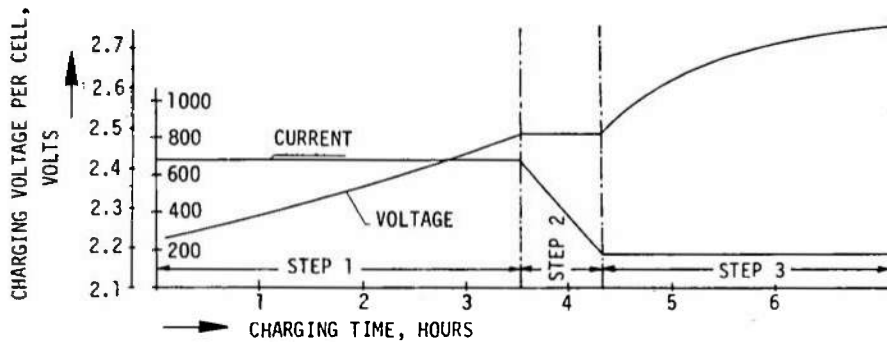

Figure 36 - Charging Characteristics of a Lead Battery

of rapid discharge to 86 percent for slow discharge. The acid density increases during charging.

During the complete charging that is required from time to time, almost all the lead sulfate is converted into lead and lead oxide. This prevents sulfation, that is, the conversion of the lead sulfate into lead crystals that are almost insoluble. The latter are very difficult to regenerate and this causes premature battery aging. The complete charging can be accomplished in two ways: (1) the battery can be charged at a constant rate (3 to 5 percent of the 5-hr discharge current flow after the second charging step) and until a cell voltage of 2.75 V has been obtained or (2) the second charging step can be extended by 25 to 35 hr at 2.4 V and very low current.

Special acid systems have recently been used to distribute the acid density and the temperature evenly within the elements.

Individual cells are combined into battery units of higher voltage by connecting their terminals with bus bars. The necessary number of cells is determined by the total voltage required.

Unless the dimensions of the individual cells are very large, two to four cells are combined in one box in order to obtain larger units for the battery arrangement. These boxes are made of glass-reinforced polyester or pressed wood (hard rubber had been used earlier). Rubber bags are inserted in the boxes to prevent the acid from reaching the box walls. The individual boxes can weigh between 0.5 and 1.0 metric ton.

The boxes that comprise a battery unit are wedged in place in the battery room by long wooden wedges in the athwartship and longitudinal directions. They are so attached to the bulkheads that they will remain as a unit even at maximum pitch and heel (see Figure 37).

The battery rooms are sealed off from the remaining compartments of the submarine; they are accessible through single battery room hatches or through a great many accesses distributed over the battery room overhead.

The boxes are passed into the battery rooms through the battery room hatches or through the smaller openings. They are loaded into the interior of the submarine through pressure-resistant battery hatches located at the upper side of the pressure hull. These hatches are opened only for loading or unloading the battery boxes.

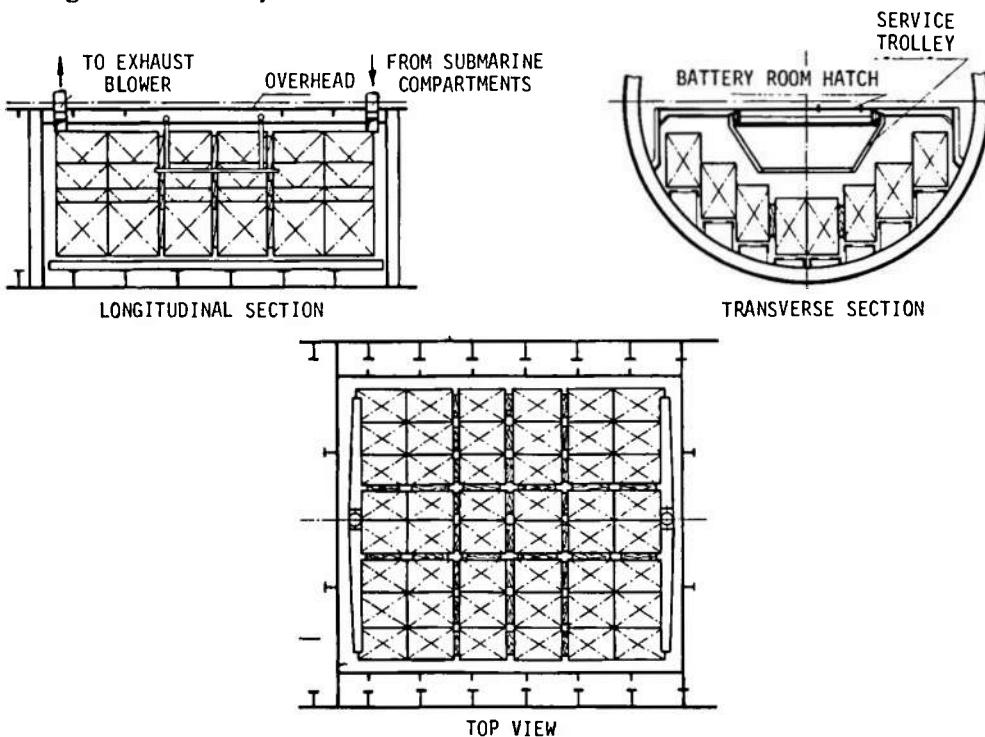

Figure 37 - Battery Installation

A battery service trolley that can be moved fore and aft is installed at a sufficient height above the boxes in the battery room.

Instead of a trolley, foreign navies mount directly on top of the boxes plastic floor plates on which service cars can travel. Servicing is from the compartment located above the battery room when the battery room overhead has small single covers.

The closed battery rooms are ventilated by exhaust blowers. The blower capacity must provide for dilution of the maximum amount of the explosive oxyhydrogen gas evolved from the battery by a factor of at least 20 in order to avoid any danger of explosion. In the case of a *central exhaust system*, the air enters through ducts from one end of the compartment above the battery room and is drawn from the other end by the exhaust system.

Earlier practice in Germany was to remove the gas from each box through separate ducts (*individual exhaust system*). This was supposed to provide for better cooling. The water losses caused by this system are greater than those from a central exhaust system.

It is operationally important to know the capacity remaining in a partly discharged battery. This residual capacity can be calculated determining as carefully as possible the total ampere-hours consumed since the last full charge. This capacity is then deducted from the capacity that corresponds to the mean discharge current. One dependable way to determine residual capacity is to measure the acid density, the temperature, and the no-load voltage for selected cells of the battery. The residual capacity can then be read from graphs.

Ampere-hour meters are usually not accurate enough to determine residual capacity.

Some of the heat loss of a battery is transferred to the surrounding water, and some is removed by the battery ventilation system. Batteries built for very short discharge periods (0.5-hr rate) require special cooling systems, e.g., the circulation of fresh water through the terminals.

Electric Engine

Electrical engines are used for propulsion and for generating electrical power for the battery and for the ship's service use (Figures 38

and 39). Separate drive motors and generators can be employed. The electric engines can be designed to alternate for propulsion and battery charging. The objective is to obtain high efficiency with minimum weight. The following additional requirements are imposed on the electric engine: good adjustability, resistance to tropical conditions, swell-proof watertightness, low noise level, and shock safety. Good adjustability is necessary because the voltage supply from the battery is variable.

A *tandem system* is always required when one propulsion engine must provide all speeds from creeping to flank. A tandem engine consists of two electric motors and one shaft mounted in one casing, with one commutator located forward and the other aft. These motor engines can be connected in series or in parallel. At least two, and sometimes three, battery units are arranged, and these can also be connected in series or in parallel. The following speeds are therefore possible:

- Slowest Speed: Engines in series and batteries in parallel, resulting in minimum voltage across the armatures.
- Average Speed: Engines in parallel and batteries in parallel, resulting in mean voltage across the armatures. Or engines in series and batteries in series, resulting in mean voltage across the armatures (greater than mean speed when the boat has three separate batteries).
- Full Speed: Engines in parallel and batteries in series, resulting in maximum voltage across the armatures. (Intermediate speeds are obtained by weakening the field.)

The main electric engines can be designed as a simple engine when there is a specific creeping approach engine for the slowest speeds. In such a case, the main electric motor can be provided with a reduction gear. Revolutions of the main drive motor can be increased to 1500 rpm. Higher rpm generally will not yield additional saving in weight because the engines must be built as turbogenerators and, in addition, commutator problems will arise.

One peculiarity of submarine engines is that armature yokes must pivot when access to the machine is not possible from below. The heat evolved is removed by sea-water coolers that are resistant to water pressure. The air cooling system is closed (Figure 39) or open. Larger engines have separate ventilation systems.

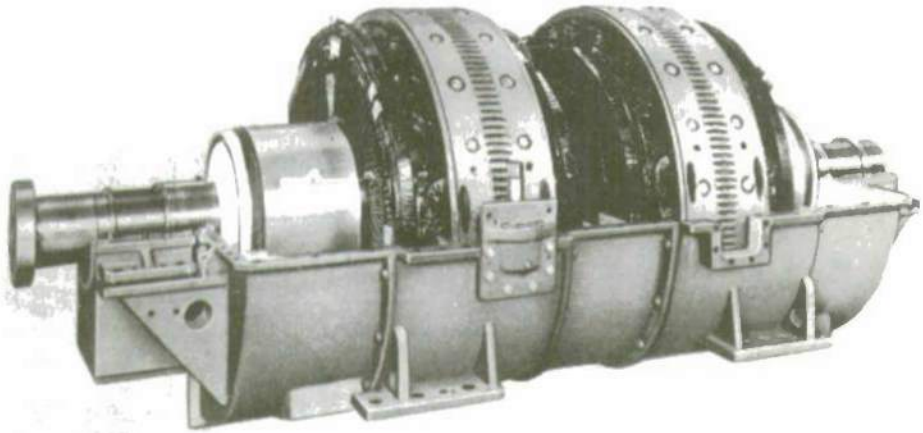

Figure 38 - Submarine Electric Engine, Open
(Drive motor for the German Type 21
submarine; $N = 2500$ hp, $n = 1500$ rpm)

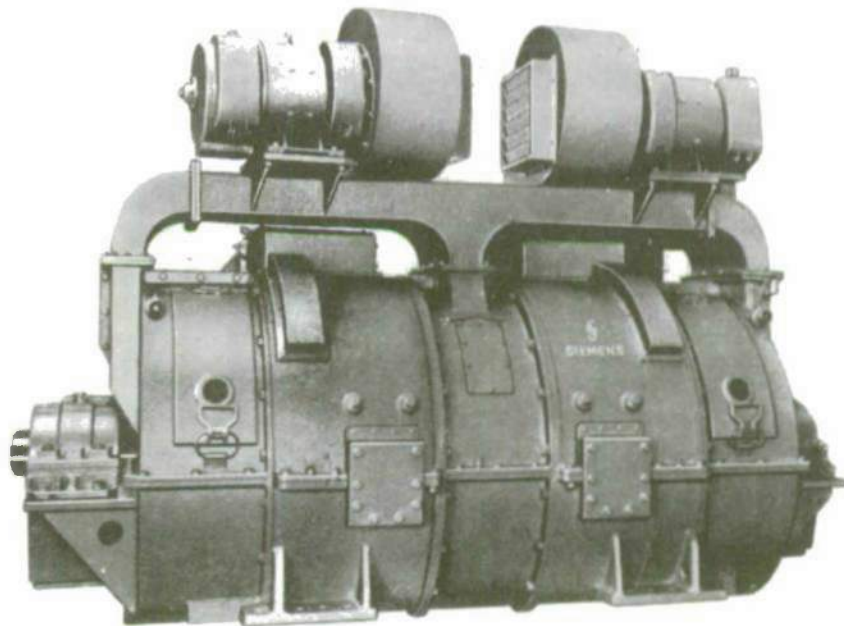

Figure 39 - Submarine Electric Engine with Air Coolers, Closed
(Drive motor for the German Type 21 submarine, 1944)

Slide bearings are usually used to achieve low-noise operation.

Low-noise motors often have a belt drive with a reduction gear and are coupled to the shaft by clutches. Cone belts are used to reduce noise.

At one time, switchboard plants had exposed blade-type switches. Today, automatic connections are also used. Every switchboard plant includes the following elements (see Figure 40): battery main switch, designed as an overload circuit breaker; battery parallel-series switch; engine parallel-series switch; main engine switch to shift from ahead to astern, or vice versa (or else a field changeover switch); field switches for intermediate speeds; and starting switches.

Diesel Engines

High-speed diesel engines (1000 to 1500 rpm) are used to conserve weight and space. In most cases, the engines are shock mounted to reduce vibration and provide some protection against shock. Additional noise-damping measures include noise insulation on the inner wall of the engine-room and the use of noise-absorbing sections to dampen the sound of water cooling lines.

It is essential that all motors intended primarily for snorkel operation have a minimum of excess air. This permits a minimal cross-sectional area for the snorkel system in the intake and exhaust ducts. Four-stroke engines are therefore better suited for snorkel operation than two-stroke engines. The engines must be insensitive to back pressure on the exhaust side.

The sea water cooling system must be able to withstand the maximum pressure encountered at snorkel depth.

Air Intake and Gas Exhaust Systems for the Diesel Engines

Diesel motors take their combustion air from the engineroom. This air enters the engineroom through a pressure-resistant air intake line (Figure 41) installed as high as possible within the free-flooding superstructure. Double valves having rubber seats closed by water pressure are used to seal these lines during submerged cruising.

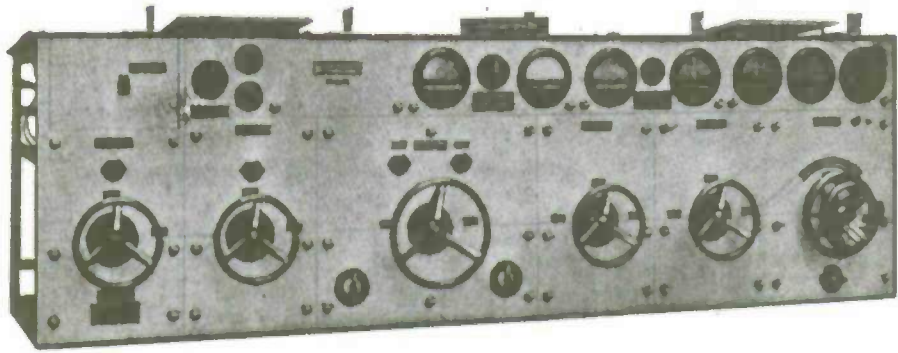

Figure 40 - Main Switchboard for a 300-Horsepower Electric Engine
(German Type 7c, 1939)

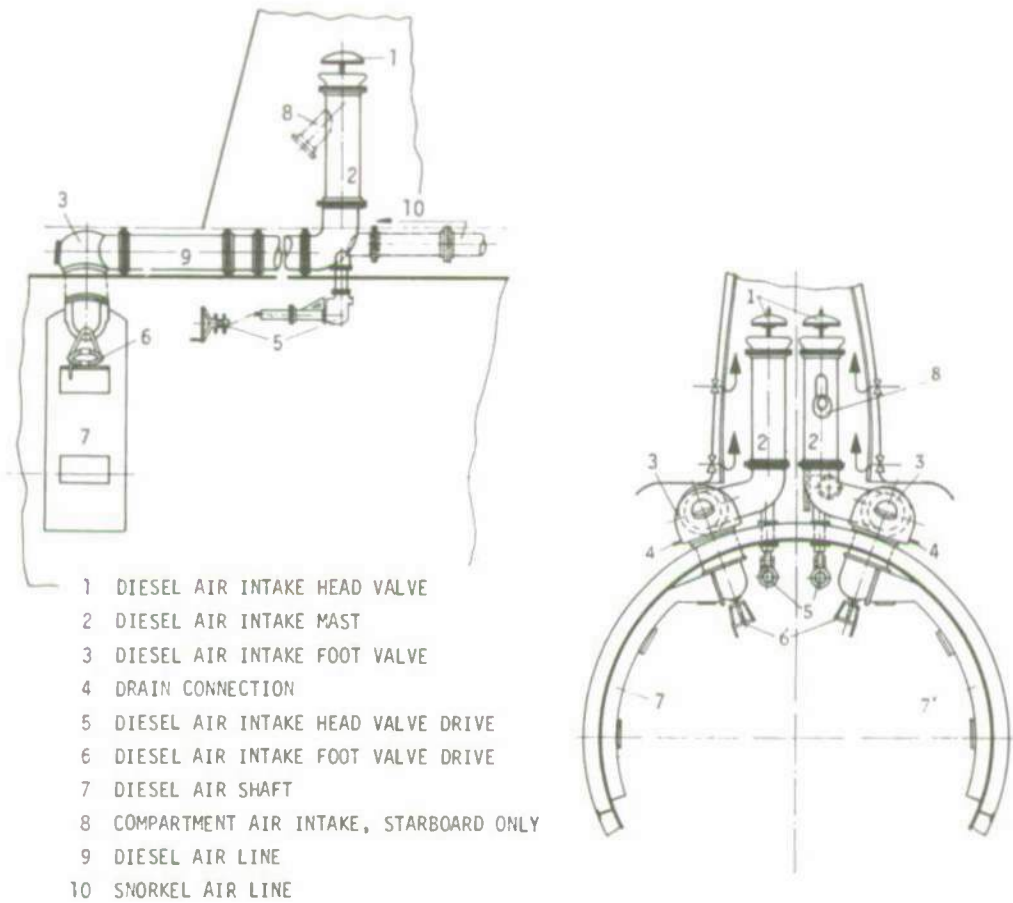

Figure 41 - Diesel Engine Air Intake System

The exhaust gas is passed overboard through water-cooled pipelines which are sealed by special pressure-resistant locking devices during submerged cruising. *Exhaust flaps* or *exhaust valves* can be used for this purpose; see Figure 42.

Because of the soot deposits that form, valve seats must be accessible for grinding. Valve disks pivot in the center (Figure 43) and can be rotated slowly by means of worm drives. To regrind the valve seat, the flap is closed until the disk rests loosely on its seat. In the German World War II submarines, the engine had to be stopped every 4 to 6 hours to regrind the exhaust flaps and thus ensure their tightness in the event of a crash dive.

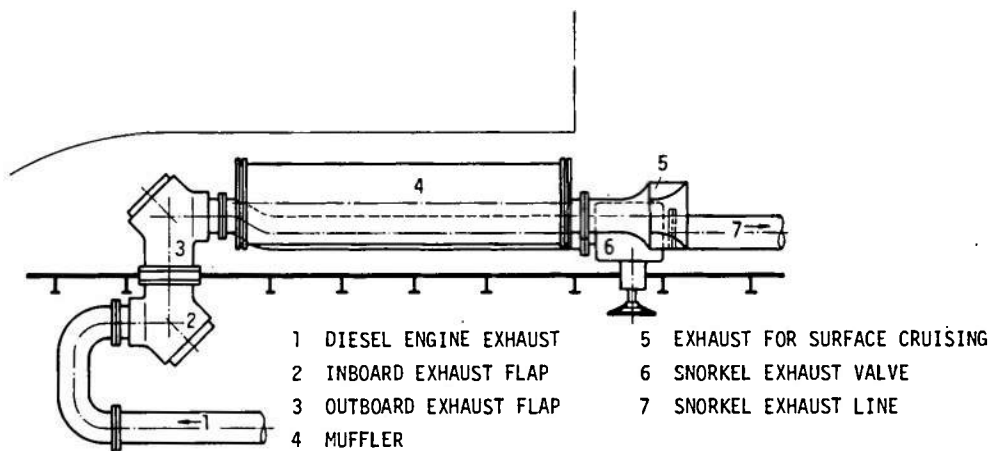

Figure 42 - Diesel Engine Exhaust System

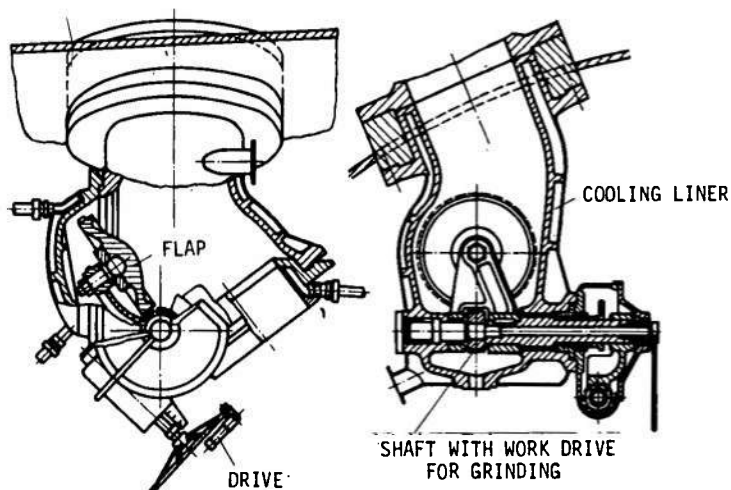

Figure 43 - Inboard Exhaust Flap

Diesel Fuel and Pressurized Water System

The fuel system in submarines differs from that in other ships in that the fuel is carried on top of sea water in the tanks. The fuel discharge lines start on top of the tanks and serve simultaneously as refueling lines. They lead to a distributor inside the submarine. As in the case of surface ships, the diesel engines are fed fuel alternately from two gravity fuel tanks, one of which is in use while the other serves as a settling tank to separate any water which may have been carried along.

The fuel is moved by water pressure. The pressurized water lines connect to the lowest points in the fuel tanks; see Figure 44. They branch off from the cooling water outlet on the diesel engines. The cooling water outlet is raised inside the free-flooding superstructure in order to have adequate head pressure when surface cruising. During refueling, the water flows from the fuel tanks through these lines to the outside. Special inspection lines are installed to provide timely warning during fuel tank refueling. They terminate in the fuel tank just above the pressurized water lines to prevent any fuel from entering the pressurized water line during the refueling operation.

Gage devices are generally no longer used at the side of fuel tanks, and consumption is monitored by meters built into the fuel lines.

Completely vented fuel tanks constitute one of the prerequisites for readiness to dive. Tanks are always vented into the submarines through special lines with stop valves. The vent lines are connected to the top of the fuel tanks; if the tanks are long, vent lines are required fore and aft. Vent valves are sometimes installed in the fuel feed lines to eliminate the need for special vent lines.

The pressure in the fuel tanks located outside the pressure hull is always equalized through the pressure in the water line. Therefore these tanks are not exposed to diving pressures. The pressurized water in tanks inside the pressure hull is activated only during surface cruising or snorkeling. These tanks must withstand the pressure required to feed fuel when snorkeling.

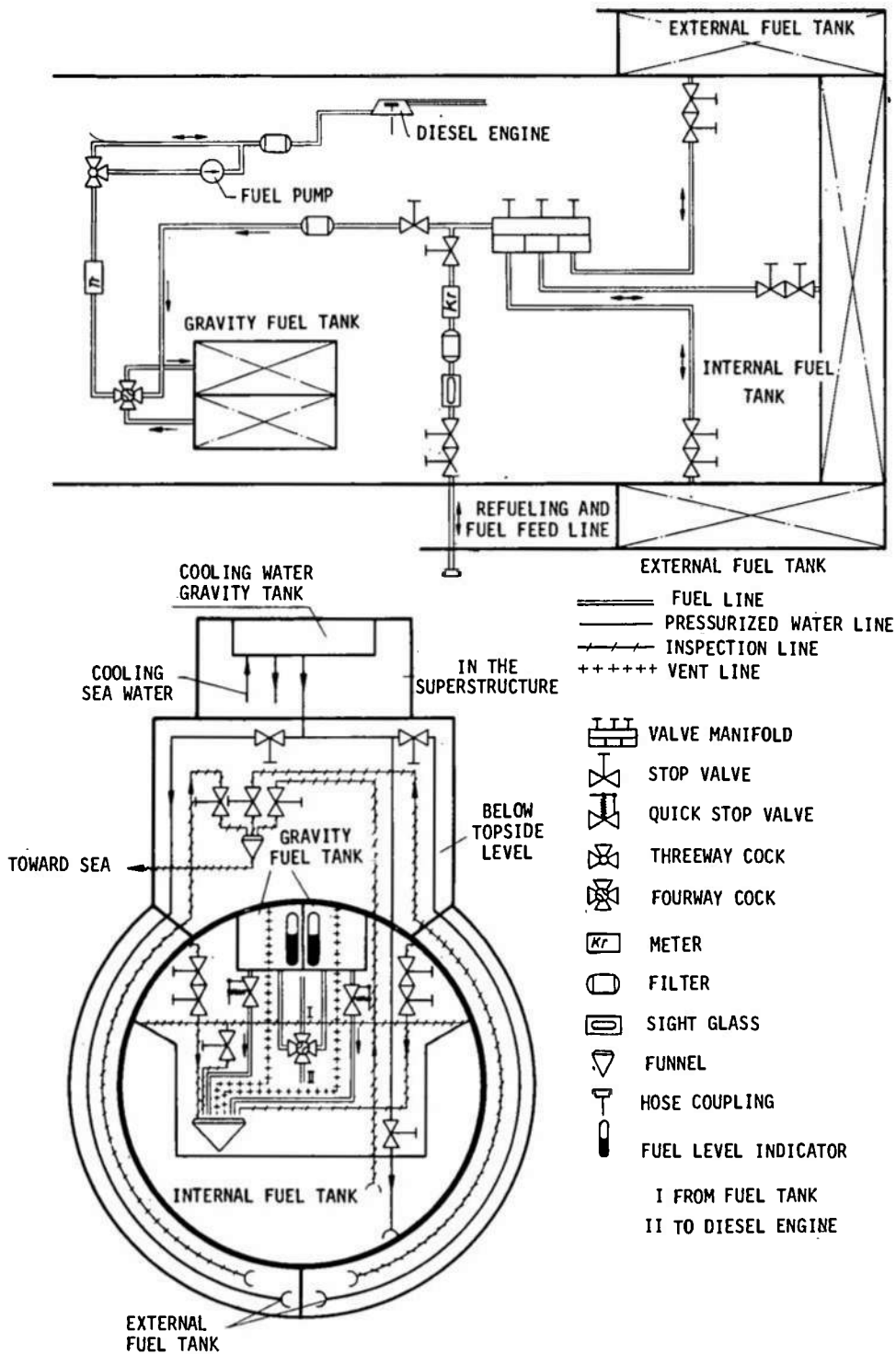

Figure 44 - Fuel and Pressurized Water System

Snorkel Systems

The purpose of the snorkel system is to ensure an adequate supply of air and to dispose of the exhaust from the diesel engines when the boat is cruising at periscope depth. This means that the battery can be recharged during slow-speed cruising without the need to surface. Moreover, extended submerged cruising is possible with the snorkel.

In the past, many submarine designers studied this problem. For example, in 1894, Simon Lake, an American, built the ARGONAUT which was equipped with an air mast for operating a gasoline motor. A Japanese submarine was lost in 1933 while operating a snorkel system. Prior to 1940, Dutch submarines were fitted with a snorkel system as proposed by J. J. Wichers, but the mast could be extended only a short distance. Submarines with this system came to England during WWII, and others were captured by Germany. Both navies removed the system because there seemed to be no need for snorkel at the time.

The German design, which was later adopted everywhere, is particularly distinguished from earlier designs by the fact that the submarine interior is used as an air buffer (see Figure 45) and so snorkel operation is possible in seaways. This configuration provides for an air supply from the snorkel air intake mast while the diesel engines are sucking air from the interior of the submarine as in standard surface cruising. As a result, when errors in depth control are made or when the boat is in a seaway, the snorkel head valve can be closed for 1 or 2 min without the need to stop the diesel engines. This causes the air pressure in the submarine to drop but it will gradually rise again when the head valve is opened.

Snorkels can be designed with folding or telescoping masts. A head valve is installed at the highest point of the air intake mast which closes just before it is flooded. The head valve need not be completely pressure-resistant. At one time it was actuated by a float (see Figure 45), but now it is usually electrically controlled and actuated by compressed air (see Figures 46 and 47). The pressure-resistant seal at the air inlet to the boat is formed by two main shutoff valves which are arranged in tandem; at least one must be designed as a quick-shutting flap. The air intake masts are flooded when folded or retracted.

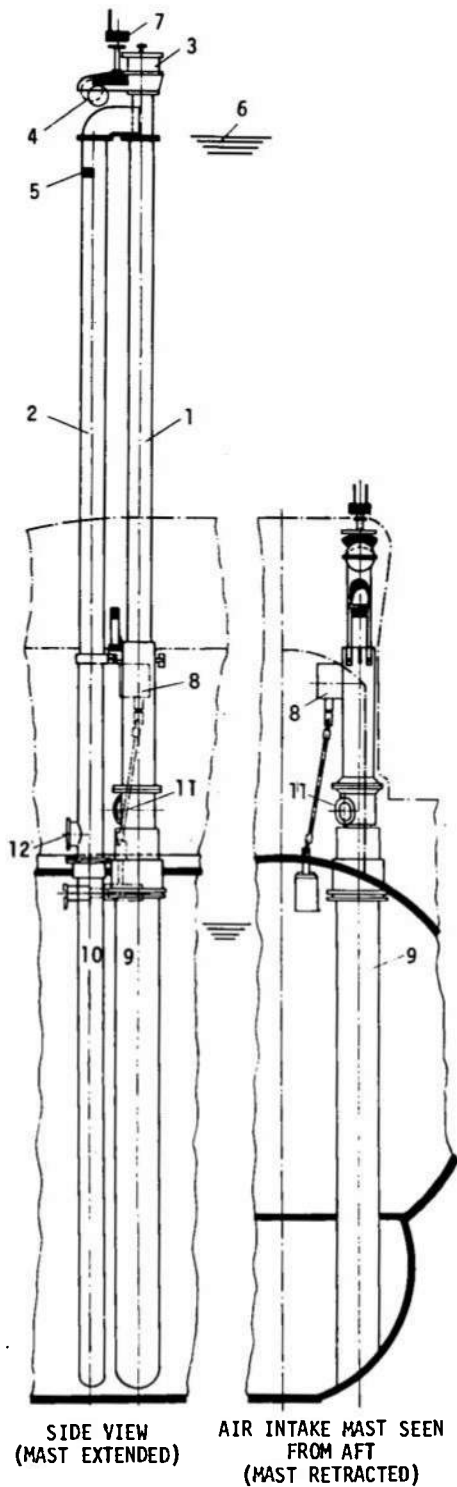

- 1 SNORKEL AIR INTAKE MAST
- 2 SNORKEL EXHAUST MAST
- 3 AIR INLET
- 4 FLOAT-ACTUATED SNORKEL HEAD VALVE
- 5 EXHAUST GAS OUTLET
- 6 WATERLINE WHEN SNORKELING
- 7 RADAR WARNING DEVICE
- 8 DRIVE FOR LIFT
- 9 PRESSURE-RESISTANT ENVELOPE PIPE FOR THE SNORKEL AIR INTAKE MAST
- 10 PRESSURE-RESISTANT FIXED-BASE PIPE FOR THE SNORKEL EXHAUST MAST
- 11 AIR EXIT (GENERALLY TO MAIN AIR INDUCTION LINE)
- 12 EXHAUST GAS INLET FROM EXHAUST GAS LINE

Figure 45 - Snorkel System Design Used in German Type 21, 1944

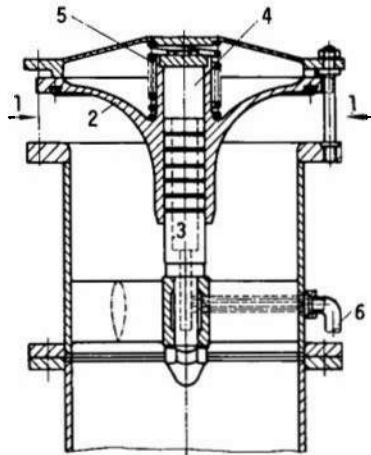

- 1 AIR INLET
- 2 VALVE DISK WITH RUBBER SEAT
- 3 FIXED PISTON WITH LABYRINTH SEAL
- 4 CYLINDER CAPACITY OF THE COMPRESSED AIR PISTON TO OPEN THE VALVE
- 5 CLOSING SPRING
- 6 COMPRESSED AIR INTAKE

Figure 46 - Arrangement for Actuating Snorkel Head Valve by Compressed Air

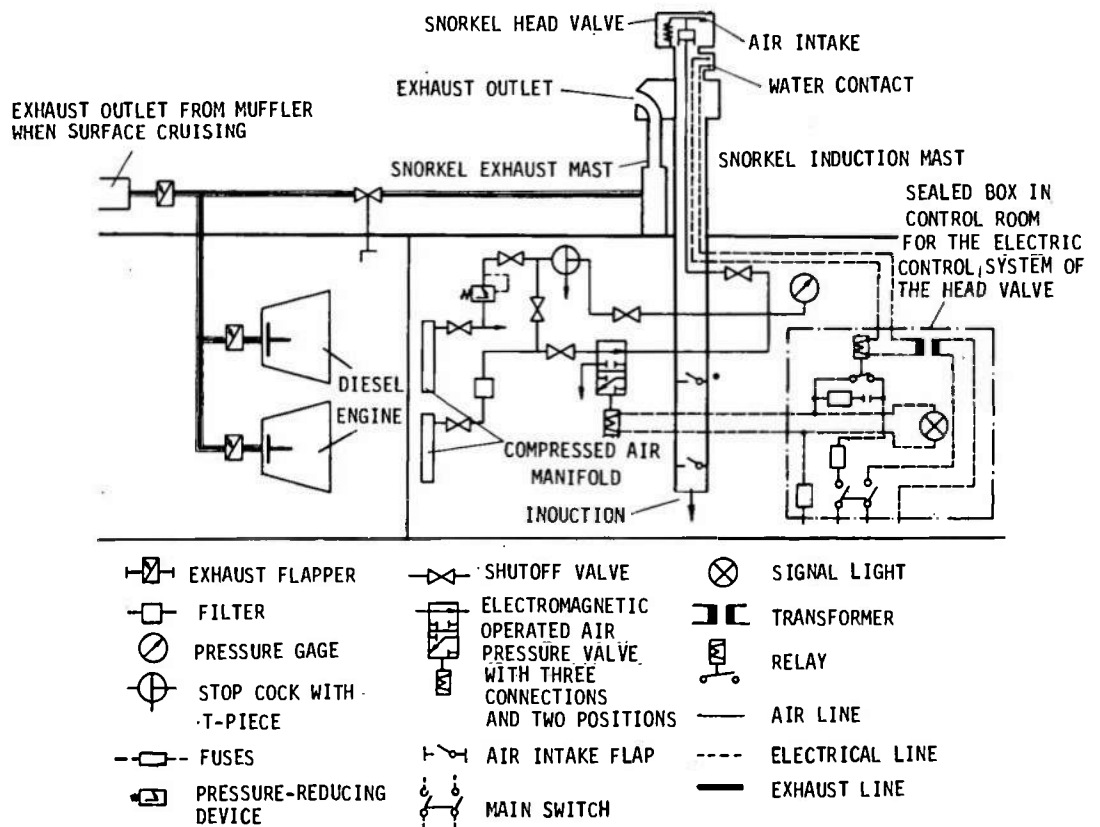

Figure 47 - Electrical Controls and Hydraulically Operated Snorkel Head Valve

Removal of exhaust gas is easier. A special exhaust mast may be extended in addition to the air intake mast, or a submerged outlet may be provided at the upper edge of the bridge, so far as the back pressure sensitivity of the engines permit.

The first German experimental plant was installed on a Type 2 submarine (250 tons) in 1943. The night/aerial periscope was replaced by an air intake mast with a float-actuated, double-seat head valve and a quick-shutting flap at the bottom. This mast was extended and retracted by the periscope hoist. The exhaust gases were eliminated by a telescope tube which was coupled to the air intake mast without any additional closure. When it was found that this system operated successfully, a program was immediately initiated to equip existing Types 7 and 9 submersibles with snorkels. Collapsing snorkels that folded forward onto the upper deck were installed because of space limitations. The new Types 21 and 23 were equipped with extending snorkels.

Up to that time, all head valves had been actuated by floats. They were troublesome because of such factors as dependence on the boat course and on wave directions and the lack of deicing facilities.

Some Type 2 submarines were fitted with extending snorkels in the winter of 1944-45. These had electrical controls and head valves operated by compressed air which were troublefree and quick acting.

During *snorkel cruising*, the submarine is semisubmerged and diving readiness is limited. In this condition, the submarine is exposed to greater danger than it is in surface or submerged cruising. The following types of disturbance are possible:

1. Flooding attributable to failure of the snorkel head valve when an error in downward depth control is made or when wave crests flow over the head valve.
2. Excess negative pressure in the boat attributable to extended undercutting (crew in danger).
3. Excess exhaust gas back pressure as a result of diving too deep. (The diesel engines can choke and flooding can occur through the exhaust lines; exhaust gas can escape backward from the air intake of the diesel.)

Any one of these three disturbances will require shut down of the diesel engines and the resulting gas that fills the boat will endanger the crew. The simultaneous closure of the quick-acting flap valves of the snorkel and the exhaust gas valves stops the charging of the batteries. Some snorkel systems do this automatically by means of a safety circuit that receives impulses from the trouble areas. When this safety circuit is energized, the automatic acting flaps are quickly closed, the diesel control levers are adjusted to zero, and the charging circuits are thus disconnected.

Snorkel cruising imposes special physical requirements on the crew because of the sudden, large pressure fluctuations (up to 200 mbar). The "snorkel fitness" of every man must therefore be determined by medical examination.

Cruising Range Calculations

Surface cruising ranges at different speeds for submarines with diesel-electric propulsion systems (see Figure 32) can be found by using this formula

$$S = \frac{V \times v}{\left(\frac{WPS}{\eta_{\text{mech}} \times \eta_M \times \eta_{\text{Gen}}} + \frac{Ne \times 1.36}{\eta_{\text{Gen}}} \right)} \times b_e$$

where

- S is the cruising range in nautical miles,
- V is the fuel stock in thousands of pounds,
- v is the surface speed in knots under trial run conditions,
- WPS is the shaft horsepower at the corresponding speed in question,
- η_{mech} is the mechanical efficiency between propeller and propulsion motor (stuffing box, thrust bearing, and transmission),
- η_M is the electric efficiency of the electrical drive motor,
- η_{Gen} is the electric efficiency of the generator,
- Ne is the mean electric power requirement for ship service use in kilowatts, and
- b_e is the fuel consumption by diesel engines in kilogram per horsepower per hour.

Calculations of cruising range must take into account such factors as sea area, season of year, and marine growth on the hull.

The formula for the cruising range of boats with direct diesel drive and electric generating plant for the board network by a coupled generator (see Figures 29 through 31) is

$$S = \frac{V \times v}{\left(\frac{WPS}{\eta_{\text{mech}}} + \frac{Ne \times 1.36}{\eta_{\text{Gen}}} \right)} \times b_e$$

Seagoing submarines can have surface cruising ranges of 10,000 nm and more at a speed of 10 knots.

The formula for submerged cruising with electric propulsion at different speeds, based on 80-percent battery discharge, is

$$S = \frac{E \times 0.8 \times v}{\frac{WPS}{\eta_{\text{mech}} \times \eta_M \times 1.36} + Ne}$$

where S is the submerged cruising range in nautical miles,

E is the electric output in kilowatt hours contained in the battery during the discharge period that applies to the speed in question (see Figure 34),

v is the submerged cruising speed in knots under trial run conditions,

WPS is the submerged shaft horsepower at the speed in question,

η_{mech} is the mechanical efficiency of the power train (gland, thrust bearing, and possibly transmission),

η_M is the electric efficiency of the propulsion motor, and

Ne is the consumption in kilowatts for ship service use.

True submarines have relatively short cruising ranges in the submerged condition. The German Type 7 (see the Appendix) had a range of 65 nm at 4 knots. These ranges are considerably longer in the case of submersibles; the Type 21 submarine (see the Appendix) obtained 320 nm at 4 knots.

Cruising ranges for combinations of snorkel and fully submerged cruising are composed of the distances covered when snorkeling and charging and the distances covered when fully submerged and cruising with electric propulsion. Detailed calculations are made to determine these ranges when speeds are varied independently during snorkel cruising and

fully submerged cruising. Battery efficiencies and the difference in drag for the two cruising conditions must be taken into consideration.

Slower mean speeds are obtained during combined snorkel and deep submerged cruising than during economical standard speed on surface.

PROPULSION DEVICES BASED ON OTHER PRINCIPLES

One disadvantage of all propulsion systems based on battery-supplied electric motors is that high speeds for submerged cruising can be used only for relatively short periods of time. Even slow submerged speeds require battery recharging within a few days at the latest, necessitating the use of the snorkel or surface cruising for several hours. Sustained, fully submerged cruising throughout a mission is impossible. Consequently, it has been a long-time desire to find submarine propulsion systems that are independent of atmospheric air.

The Walter Principle

H. Walter developed his technique between 1936 and 1945 (see Figure 48). About 80 percent concentrated liquid hydrogen peroxide (H_2O_2) is used as the oxidant. Decomposition in a decomposer generates water vapor and free oxygen ($2 H_2O_2 \rightarrow 2 H_2O + O_2$). The latter is used in a combustion chamber to burn a hydrocarbon (fuel) to produce carbon dioxide (CO_2) and water vapor (H_2O). This mixture is used as the medium to drive a propulsion turbine.

The liquid hydrogen peroxide T-substance is stored in plastic bags in the free-flooding outer hull. As the liquid hydrogen peroxide is consumed, the bags collapse and the volume is replaced by sea water (specific gravity of about 1.33).

Fuel is required for this process as well. A synthetic light oil is employed. It is stored in the outer hull tanks on top of water and loaded according to the conventional method. The submarine gets considerably lighter as the liquid H_2O_2 is consumed. Consumption of the light fuel makes the submarine heavier. The weight reduction, however, is much greater and must be compensated for in the trim tanks, which are therefore much larger in the Walter submersibles. The peroxide is pumped into the decomposer where it is decomposed by a catalyzer into water vapor and O_2 .

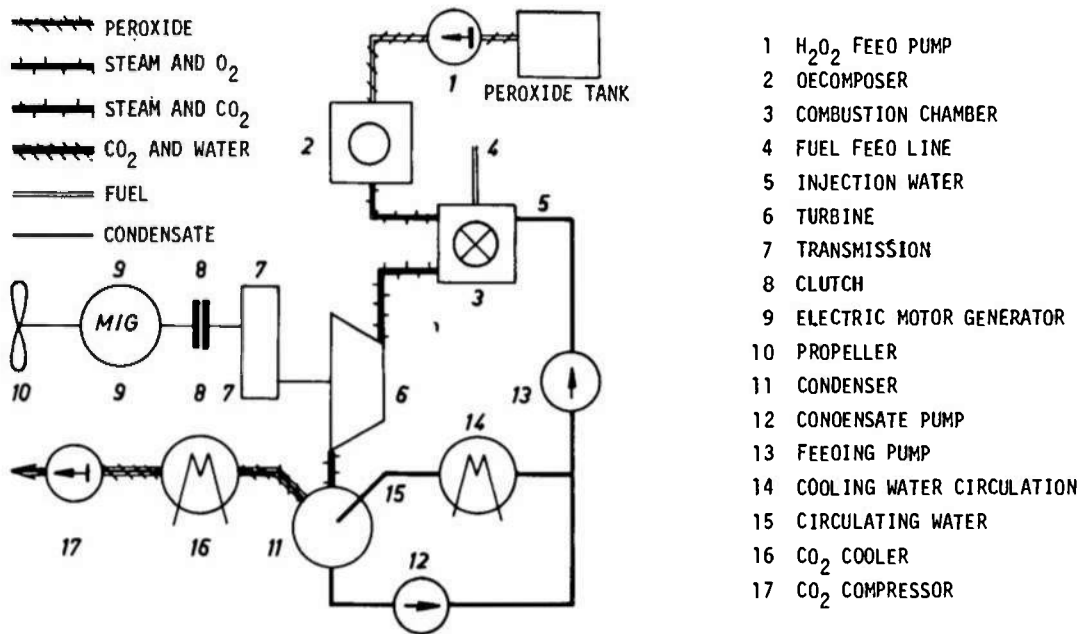

Figure 48 - The Walter Submarine Propulsion System

The temperature of this mixture is about 450 C. The pressure corresponds to the turbine inlet pressure. This mixture of steam and oxygen then enters the combustion chamber, and light fuel and water are injected at the same time. Continuous combustion generates a mixture of water vapor and CO₂ which flows through a dust filter into the turbine. An injection condenser is used to condense the water vapor. Part of the condensate is pumped overboard, but the remainder is cooled in a recoler device and injected into the combustion chamber. The CO₂ is pumped outboard where it dissolves in sea water after rising a short distance. The considerable electric power required for the pumps, etc., is satisfied by using a coupled generator. Since the exhaust CO₂ must overcome the water pressure, the turbine also operates against the water pressure, resulting in a consumption of peroxide and light fuel.

The installation of a special compressor for the CO₂ exhaust increases the head pressure in the turbine, makes the system much less dependent on water pressure, and lowers the consumption rates.

In addition to this direct procedure, an indirect method was developed which includes a closed-loop steam circuit with a condenser for the turbine. The steam is generated in a heat exchanger heated by the steam and CO₂ mixture emerging from the combustion chamber. The steam of

the mixture is condensed in the heat exchanger and the condensate is pumped overboard with the CO_2 . The indirect technique has a much lower consumption rate. However, this system is somewhat heavier and requires more space.

The first Walter system, a so-called "cold" system, built for test purposes only and developed even before the employment of the direct procedure. It was installed in test boat V-80, an 80-ton experimental submarine, in 1939 (see Figure 49). Only the peroxide was decomposed, so that the turbine operated on a mixture of steam and oxygen. The free oxygen escaped to outboard and left a bubble path. The specific peroxide consumption was high. The submarine was able to develop 2000 shaft horsepower, giving it a speed of 28 knots.



Figure 49 - The Experimental Walter Boat V-80 during Surface Cruising, 1939

The Walter principle permits the installation of a very high engine rating at low weight and space requirements. In the case of the direct procedure, without compressor, the peroxide consumption is about 3.2 kg/hp/hr. The rate drops to about 2.5 kg/hp/hr if an additional compressor is installed. The indirect technique can provide a figure of 1.8 kg/hp/hr. At the time, these consumption rates made it impossible to carry sufficient peroxide to cruise on the Walter system exclusively for an entire mission. In addition, therefore, a diesel-electric system with snorkel was installed for standard cruising.

The plant (Figure 50) had been planned for the German Type 26. This submarine was to carry 97 tons of H_2O_2 and 65 tons of fuel. The Walter system was to operate by the direct procedure with compressor. The following cruising ranges had been planned:

Submerged cruising range 144 nm at 24 knots (maximum speed on the Walter system).

Submerged cruising range 100 nm at 4 knots on electric drive (low-noise motor) (the maximum submerged speed on electric drive was 10 knots).

Surface cruising range 7500 nm at 10 knots on direct diesel drive.

The system was investigated on a test stand, but it never was installed on the Type 26 because of the end of the war.

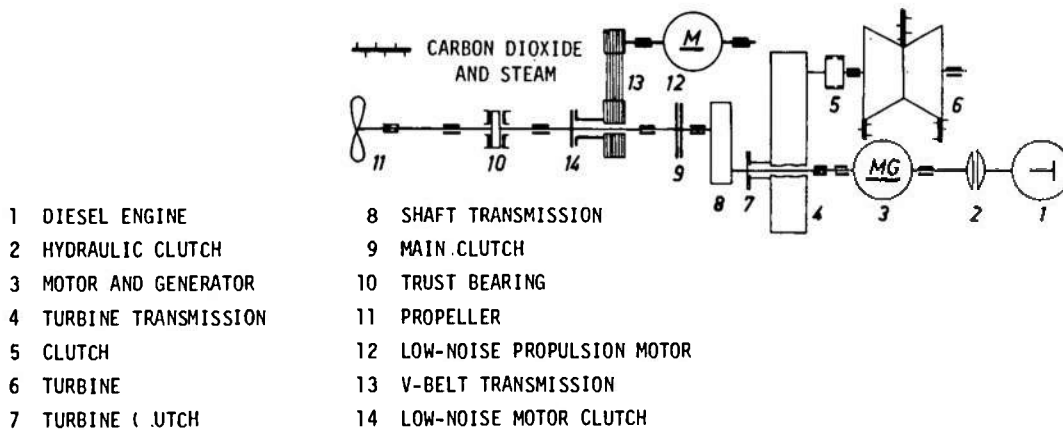

Figure 50 - Propulsion System used in the German Type 26

Closed-Cycle Principle

Here the diesel engines operate during submerged cruising on pure oxygen carried aboard in liquid or gaseous form (see Figure 51). The diesel engines operate on atmospheric air during surface and snorkel cruising, but can be shifted to "closed-cycle operation" for submerged cruising. Then the nitrogen component in the atmospheric air is replaced by the CO_2 in the exhaust gas, and atmospheric oxygen is replaced by oxygen from the on-board supply. An electric drive system and battery are also required for underwater low-noise propulsion.

- 1 OXYGEN TANK
- 2 PRESSURE-REDUCING VALVE
- 3 OXYGEN METERING CONTROLLER
- 4 MIXING NOZZLE
- 5 AIR INLET FOR SURFACE CRUISING
- 6 DIESEL ENGINE
- 7 TRANSMISSION
- 8 CLUTCH
- 9 ELECTRIC DRIVE MOTOR
- 10 PROPELLER
- 11 EXHAUST COCK
- 12 GAS COOLER
- 13 BYPASS FOR TEMPERATURE CONTROL
- 14 COOLER
- 15 PRESSURE CONTROLLER FOR CIRCULATION PRESSURE
- 16 EXHAUST COMPRESSOR
- 17 SEPARATOR
- 18 FUEL
- 19 EXHAUST OUTLET FOR SURFACE CRUISING
- 20 EXHAUST OUTLET FOR CLOSED-CYCLE OPERATION
- 21 EXHAUST LINE FOR CLOSED-CYCLE OPERATION

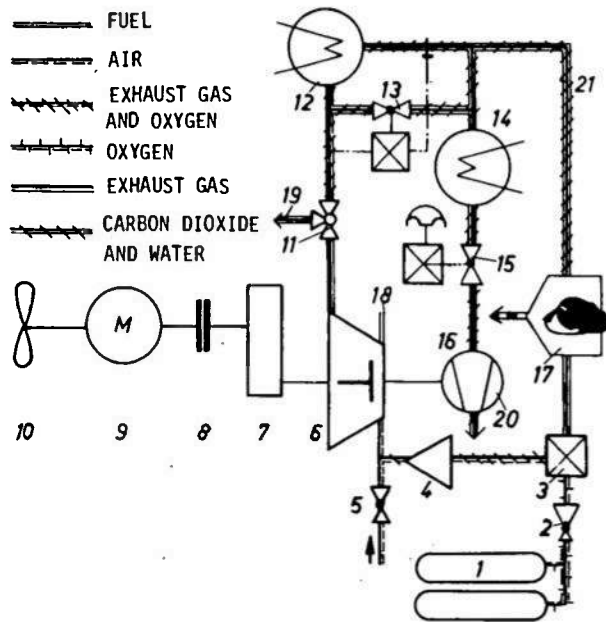

Figure 51 - Closed-Cycle System for Submarines

The advantage of these closed-cycle systems over the Walter system is that surface and snorkel cruising do not deplete the on-board oxygen supply. However, the problems involved in oxygen storage and weight compensation for consumed oxygen are relatively difficult to solve.

Closed-cycle systems have operated successfully on the test stand, but no information is available on any installation aboard a submarine.

Nuclear Propulsion Plant

Nuclear systems for submersibles consist of steam turbine plants in which the reactor assumes the function of the boiler. Maximum sustained output and unlimited submerged cruising ranges are possible. The dead weight of these systems is still high because of the radiation shielding required. Consequently, all submarines built to date have a displacement of several thousand tons, so they can be employed only on the high seas. Nuclear propulsion systems are ideal for submersibles except for weight and cost considerations.

CHAPTER XI

SHIP HANDLING EQUIPMENT

CONTROL SURFACES

Except for folding or retractable planes, the design of diving planes and rudders do not differ appreciably from the rudders of other ships. The profile shaped rudder sections and diving planes must be free-flooding to prevent damage by water pressure. Manually operated diving planes have weights along the leading edge to achieve a balance of its natural weight about the axis of rotation.

Complicated designs have been developed in order to remove the bow planes from the flow around the submarine during surface cruising and high-speed submerged cruising. The following arrangements (Figure 52) are possible: (1) planes can be folded against the outer hull, (2) they can be folded inward and aft into slots in the outer hull, or (3) they can be pivoted about their vertical axes so that one rudder blade is retracted forward and the other aft into the outer hull.

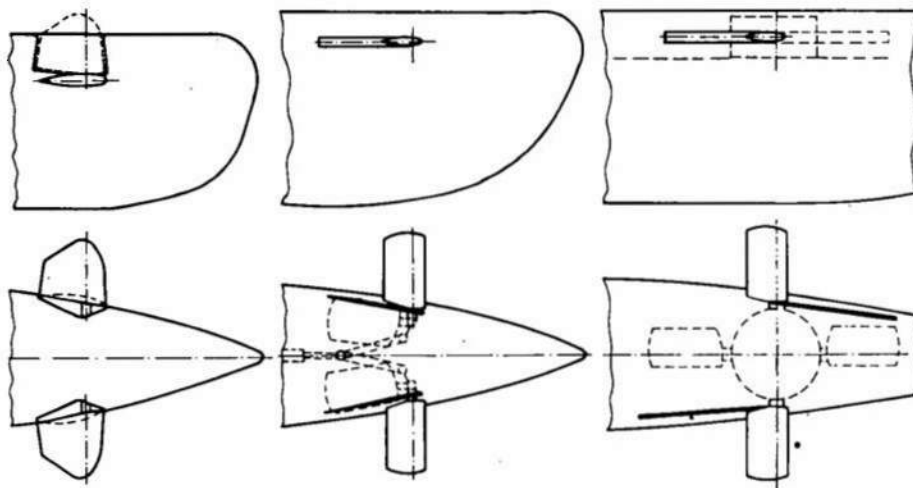

Figure 52 - Folding and Retractable Diving Planes

The electric or hydraulic drives of the control surfaces are located inside the pressure hull. Power is transmitted to the planes by linkages and shafts. The main power drive is backed up by some other type of power drive (e.g., it is possible to switch to another circuit in the case of electric drives) or by manual operation in an emergency. The depth control stations are located on the starboard side (see Figure 53) in German submarines and the depth helmsmen are seated side by side and facing starboard. These stations are on the port side in foreign submarines.

➤ The German V-80 Walter-propulsion boat (1939, see Figure 54) was the first German submarine to be fitted with a combination control for the rudder and aft stern depth plane now customarily used on present-day U. S. submersibles. In this configuration the helmsmen faced forward. One man operated the rudder by turning a control column and by pushing and pulling the aft depth planes. A second man was used to operate the bow planes when their use was required at slow speeds.

Many submarines have automatic depth control systems to relieve the crew during snorkel cruising and sustained submerged cruising. Mechanical-hydraulic systems and electronic-hydraulic systems are known. Automatic rudder steering systems are also employed to relieve the crew on long cruises.

➤ BALLAST TANK EQUIPMENT

As indicated in Chapter V, ballast tanks provide the buoyancy needed for surface cruising. Vents are designed in the form of flaps or valves (Figure 55). They open outward, or better still inward, and seal against a rubber seat. They are activated either by levers and linkages or by shafts and worm gears. When they open outward, they must be self-locking so that they cannot be lifted by pressure in the ballast tank. In smaller submarines, the drives are operated manually by aximeters or linkages. In large submarines, they are operated by compressed air or hydraulically and require an additional manual drive for emergencies. Some submarines have emergency vent valves below the main vents on some ballast tanks. These can be used to maneuver when the regular vents fail, but they are open during normal operation.

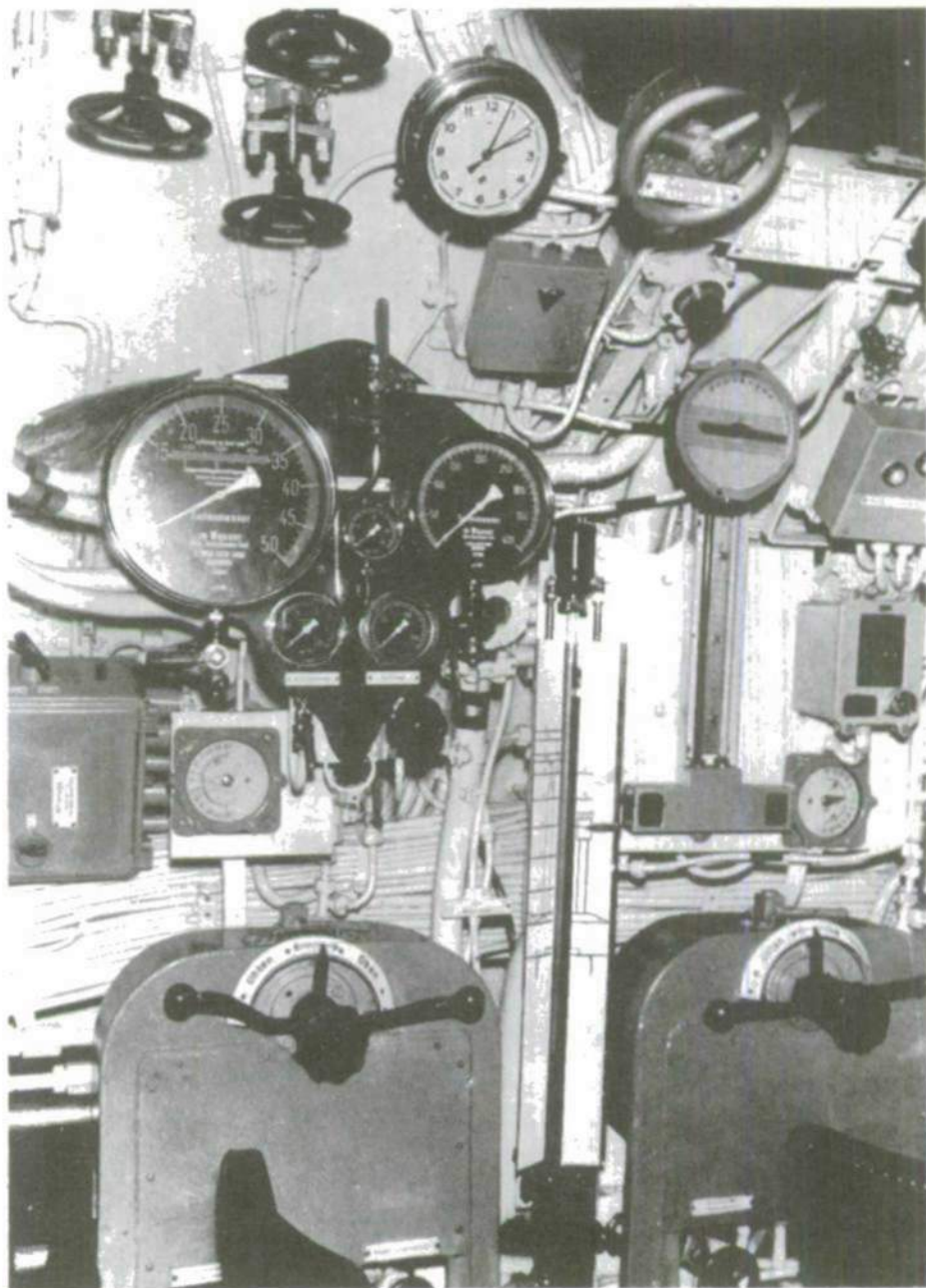

Figure 53 - Depth Control Stations in the Control Room
(German Type 21, 1944)

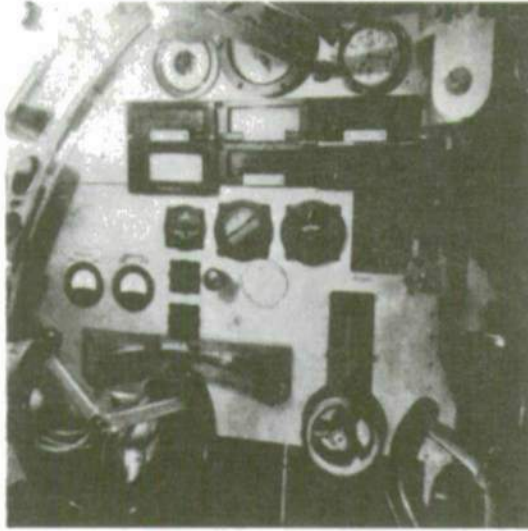
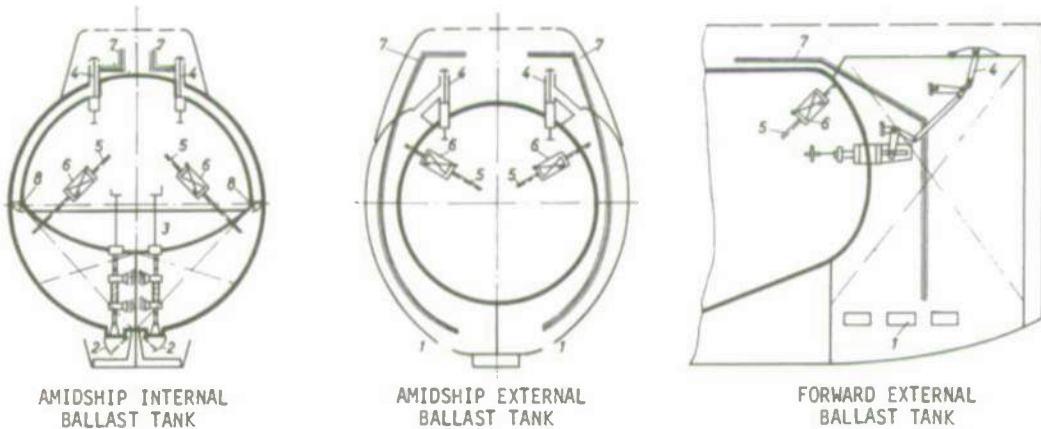

Figure 54 - Combination Rudder and Diving Plane Controls
(Walter Experimental V-80, 1939)



AMIDSHIP INTERNAL
BALLAST TANK

AMIDSHIP EXTERNAL
BALLAST TANK

FORWARD EXTERNAL
BALLAST TANK

- | | |
|---|---|
| 1 FLOOD SLITS | 6 BOARD BLOW VALVE (BACK PRESSURE VALVE) |
| 2 FLOOD FLAP | 7 EXHAUST LINE (DIESEL EXHAUST FROM THE EXHAUST DISTRIBUTOR) |
| 3 FLOOD FLAP DRIVE | 8 EMERGENCY SHUTDOWN FLAP (OPERATED MANUALLY FROM THE CONTROL ROOM) |
| 4 VENT | |
| 5 BLOW LINE (COMPRESSED AIR FROM THE AIR DISTRIBUTOR) | |

Figure 55 - Ballast Tank Equipment

Instead of the simple flooding ports used today, earlier practice provided flood flaps activated from inside the pressure hull by spindles and levers. These opened outward and had rubber gaskets as seals.

The compressed air lines for blowing the ballast tanks have a back pressure valve located in the side of the submarine to prevent water from entering the blow line during submerged cruising. Moreover, it prevents accidental venting of the ballast tank through the blow line during surface cruising in the event of erroneous operation of the compressed air system. Blow lines that are used to blow ballast tanks with diesel exhaust gas or with a special low-pressure blower require greater cross sections than do high-pressure blow lines. In most cases, ~~low-pressure-blow-lines-extend~~ to the bottom into the residual water in the ballast tanks. This arrangement prevents empty ballast tanks from being flooded backwards through these low-pressure blow lines in the event that the pressure accidentally drops below the back pressure during ballast blowing operations.

The advantages of using diesel motors to blow ballast tanks include their greater simplicity, lower weight, and smaller space requirement. Another advantage is the preservative effect of the diesel exhaust gas on the surface of ballast tanks. The prerequisite for diesel engine blowing systems is that the diesel engines be insensitive to back pressure and that they start easily.

PRESSURE HULL CLOSURES

The most important closures are the hatches; these are categorized as access and torpedo hatches. Access hatches have horizontal seats whereas those of torpedo hatches are inclined so that torpedoes can be loaded.

Hatch covers (Figure 56) are made of cast steel with circular rubber gaskets and are stronger than the pressure hull to allow for an adequate safety margin. The heavy hatch cover is externally spring balanced for easy handling. A hatch cover is held in the closed position by a snap latch which can be activated from inside or outside.

This snap latch can be held in the "open" position from the inside by a blocking device, but it can be operated in an emergency should the crew need to use the hatch to escape from a flooded submarine. When released, the hatch cover can be opened with the help of the inside air bubble.

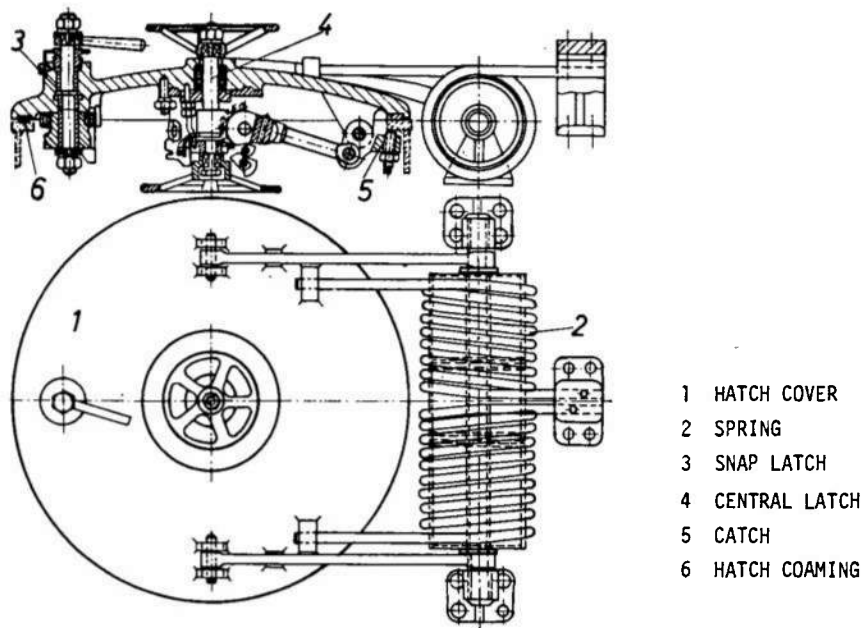

Figure 56 - Hatch Cover

During submerged cruising, the hatch cover is secured by a central latch that can be operated from inside or outside. Three catches spaced 120 deg apart hold the hatch cover closed so tightly that it cannot be raised by force.

When the hatch cover is open and in the vertical position, a small pendulum trap blocks the central latch and prevents it from being accidentally turned in the "closed" direction. Without this feature, the catches would hit the hatch coaming when the cover is being closed and prevent its immediate closure.

The conning tower hatch is fitted with a small transit cock. When the submarine is trim tested, this cock is used to determine that the hatch cover is flooded; the depth gages are then calibrated. Hatches are usually paired; for example, the conning tower hatch is paired with the control room hatch which is located below.

An exception was made by the former German Navy, which was satisfied with single deck and torpedo hatches.

The following principles apply to all other pressure hull closures such as valves, flaps, and so forth. All closures are in a double

arrangement. The outer closures are placed as closely as possible to the pressure hull shell and the inner closures as closely as possible behind the outer closures. The outer closures must close under external pressure; locking features for the "closed" position prevent a closure from opening under blast. All such closures are designed for greater strength than the pressure hull.

In the German Navy, the hand wheels or cranks for outboard closures could be distinguished by touch and so a particular control could be identified in the dark (see Figure 57).

EQUIPMENT FOR DRAINING AND FLOODING

One prerequisite for the diving readiness of any submarine is that the bilges are drained except for the residual water and that the proper weight of the boat is maintained by filling the regulating cells. Thus, the drain and flood systems have special significance for safe submerged cruising.

The main drain extends in a straight line through the length of the whole submarine (see Figure 58). It is divided by stop valves into a forward and an aft line. The suction baskets must be easily accessible and located so that the bilges can be drained sufficiently even when the submarine is very heavy at the bow or stern.

The drain lines are filled with water at all times to ensure that the drain pumps can operate immediately in any emergency. Vents are located at the ends of the drain pipe to permit venting. The water in the drain lines constitutes part of the weight of the boat and is therefore included in the weight calculation.

Two drain pumps are used in most cases. A piston pump (Figure 59) is used for dependable removal of small quantities from the bilges and will operate against maximum diving pressure.

A double-stage, high-capacity rotary pump is usually available as well. At shallow depths and during surface cruising, the impellers are connected in parallel (pumping the full amount). At greater depth, the impellers are connected in series (pumping one-half the amount). These pumps have electric drive and are installed amidships in the control room or in a special auxiliary engineroom.

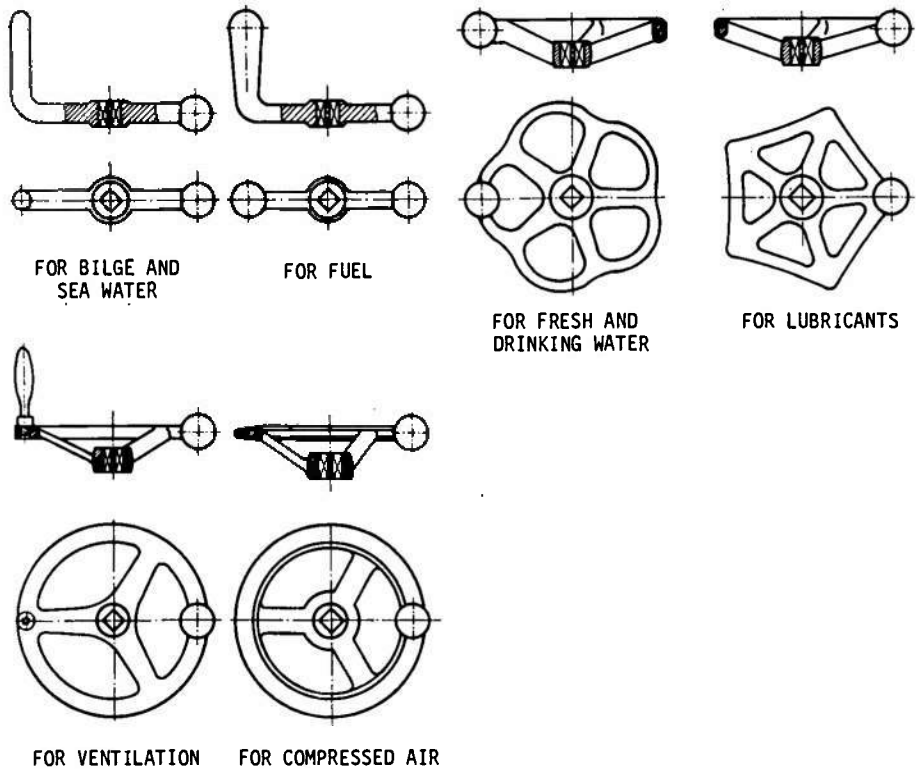

Figure 57 - Handwheels and Cranks for Outboard Closures

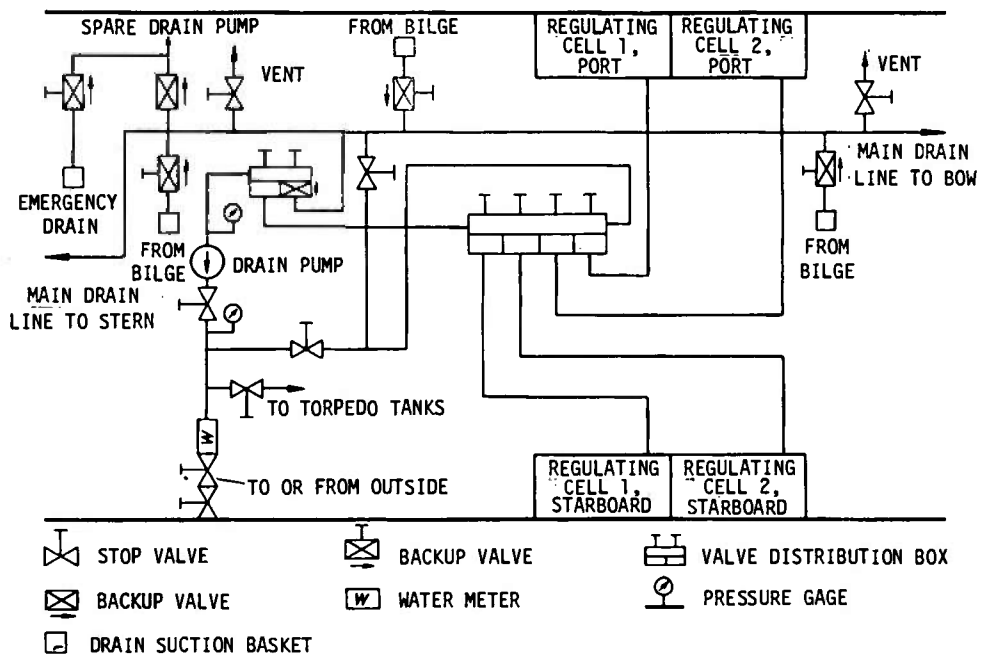

Figure 58 - The Drain and Flood System

Long submarines require additional drain pumps at the ends of the pressure hull because the pumps installed amidships cannot pump water during heavy trim of a long submarine. A hand drain pump is usually part of the installation. It can be used to pump water from the bilges into a regulating cell during submerged cruising when drain pumps have failed (e.g., in the event of a power failure). Water is blown out of this cell by compressed air.

The flooding and pumping system for the regulation cells is connected to the bilge drain system. Its operation is described in Chapter V. Control is from the drain and flood distributor located amidships in the control room or in the auxiliary engine room. The regulating cells can be flooded from outside through this distributor or the water in them can be blown overboard by compressed air. In addition, the drain pumps can bring water from outside or from the bilge line into the regulating cells. Finally, the regulating cell can be drained by the drain pumps.

When a hydrostatic gage is installed, its valves (see Chapter V, page 18) are also connected to the flood and drain distributor. This gage is used to control the rate at which one regulating cell is flooded and another emptied.

EQUIPMENT FOR TRIMMING

This equipment controls the trim of the boat required for submerged cruising. Figure 60 shows a trim installation based solely on the use of compressed air for trimming; its operation is described in Chapter V. The advantages of this installation are reliability and absence of noise. Operation with compressed air has the disadvantage that internal air pressure will rise considerably during sustained submerged cruising.

Some systems use a reversible displacement pump in the trim line.  The advantage is that no compressed air is consumed. The disadvantage in long submarines is that a pump cannot obtain a suction when the trim angles are too great because of the excessive suction head.

German submarines used the reciprocating drain pump as a trim pump through an alternating valve. This arrangement was abandoned in 1943 because the pump was too noisy.

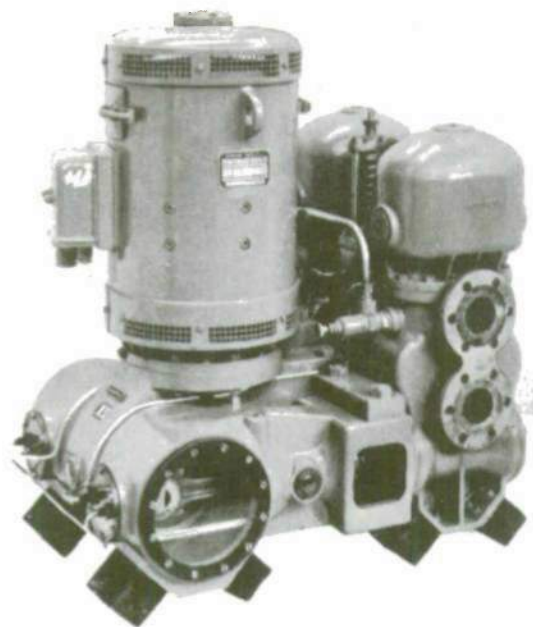

Figure 59 - Reciprocating Drain Pump

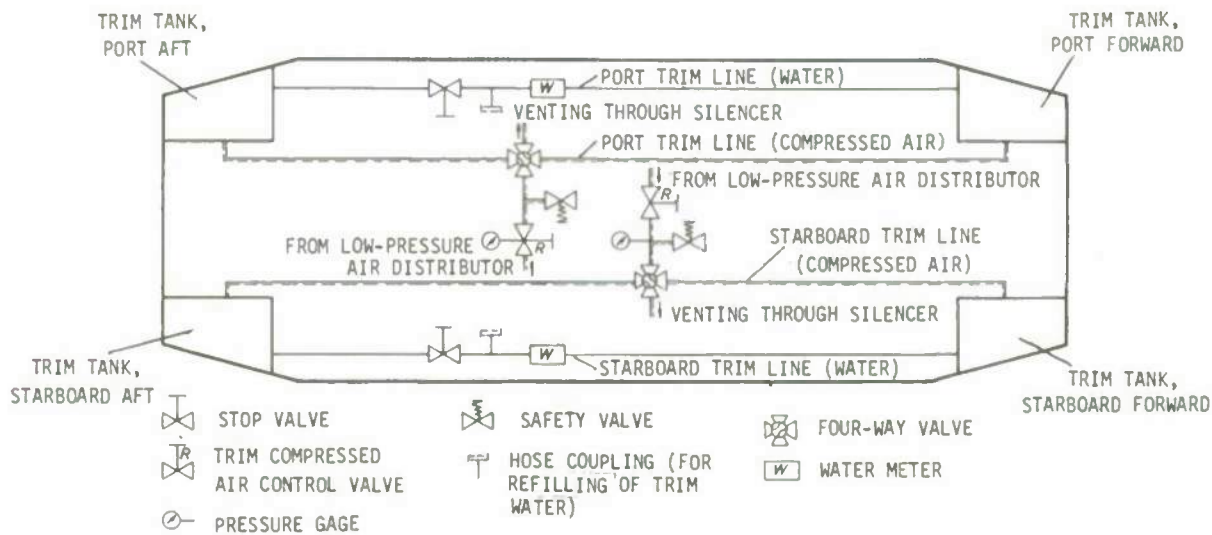

Figure 60 - Trim Equipment

COMPRESSED AIR SYSTEM

This system is very important to a submarine because air under high pressure contains a large amount of energy that can be used to obtain maximum output in minimum time. Functions handled by compressed air vary greatly.

The compressed air carried aboard a submarine is an important means of saving lives when additional buoyancy is required in an emergency during submerged cruising (blowing ballast tanks). Compressed air is also used to initiate the normal surfacing maneuver by blowing the ballast tanks. Furthermore, compressed air is used for emptying the regulating cells; for trimming; for completely emptying the main ballast tanks on the surface; for starting the diesel engines; for grinding the exhaust flaps; for blowing boat valves that have become clogged with sand on the bottom; for operating engine clutches, switches, and quick-acting flaps; for operating the snorkel head valve; for actuating the whistle, and possibly for operating the anchor winch, for machine tools, etc.

The torpedo armament requires compressed air for flooding and blowing torpedo tubes. Several types of tubes require compressed air for firing.

The compressed air, whose storage pressure can be 200 atm and higher, is generated aboard the submarine. The most widely used compressors are four-stage, water-cooled, piston compressors with electric drive (Figure 61). They obtain their suction from the compartment in which they are installed. The compressor can also be driven by the main propulsion motor in small, simple submarines. A water separator is installed behind the compressor to prevent the water in the humid sucked air from reaching the compressed air system.

The compressors are started primarily during snorkel and surface cruising to replenish the compressed air supply. They are used during submerged cruising to eliminate the excess pressure which develops in the submarine from time to time.

German submarines used four-stage free-piston compressors (Junkers compressors) in addition to electric-drive piston compressors. They operated on the two-stroke diesel method, generating air directly by diesel fuel combustion. Their pumping capacity was considerably greater than that

of electrically-driven compressors of the same weight. However, these compressors cannot be used during snorkel cruising because they cannot overcome exhaust back pressure and so are not feasible for use in submersibles.

Compressed air is stored in steel flasks located inside or outside the pressure hull. External storage has the advantage of better space utilization. In such a case, two or three cylinders are combined into one group served by a common stop valve. One flask can have a volume of as much as 0.5 m^3 . The total air supply is determined by the size and type of the submarine and by its diving depth. Submersibles that must dive and surface frequently require a greater supply of compressed air than those that remain basically submerged. The weight of the stored compressed air is included in the weight calculation. The compressed air flasks are connected in units to the high-pressure air distributor to which the compressor is also connected (Figure 62). Distributors at different pressure levels are supplied from this station. The following distributors may be available:

1. The torpedo high-pressure distributor. This is located near the torpedo tubes.

2. The ballast blow distributor. The initial blow pressure is manually controlled through the main ballast blow valves but is limited by a safety valve and is about twice as large as the maximum diving pressure. The blow lines lead from the blow distributor through valves to the individual ballast tanks.

Because the main blow valve can freeze and become temporarily inoperative as a result of a combination of steady blowing and cold, wet compressed air, a spare blow valve is provided parallel to it. The ballast blow manifold should be located in an easily accessible part of the control room to facilitate dependable monitoring of the ballast blowing procedure.

3. The discharge distributor. This is connected to the pressure fittings on the regulating cells. The pressure is adjusted manually by using the main valve of the discharge distributor.

4. The low-pressure distributor. This carries a constant pressure which is controlled by a pressure-reducing valve (10 to 12 atm). All other consumers are supplied from here. If the reducing valve should fail, the pressure can be regulated manually by a control valve located parallel to the reducing valve.

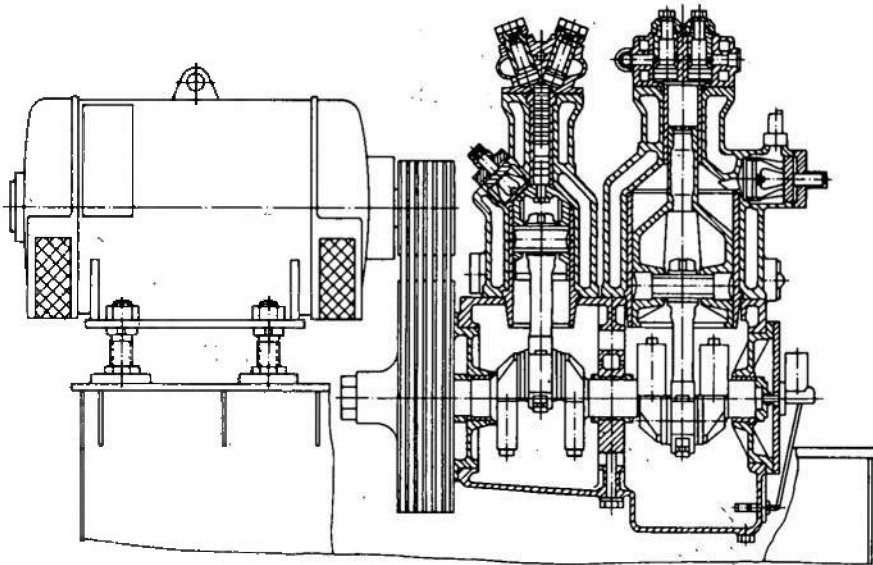

Figure 61 - Four-Stage High-Pressure Air Compressor with Electric Drive

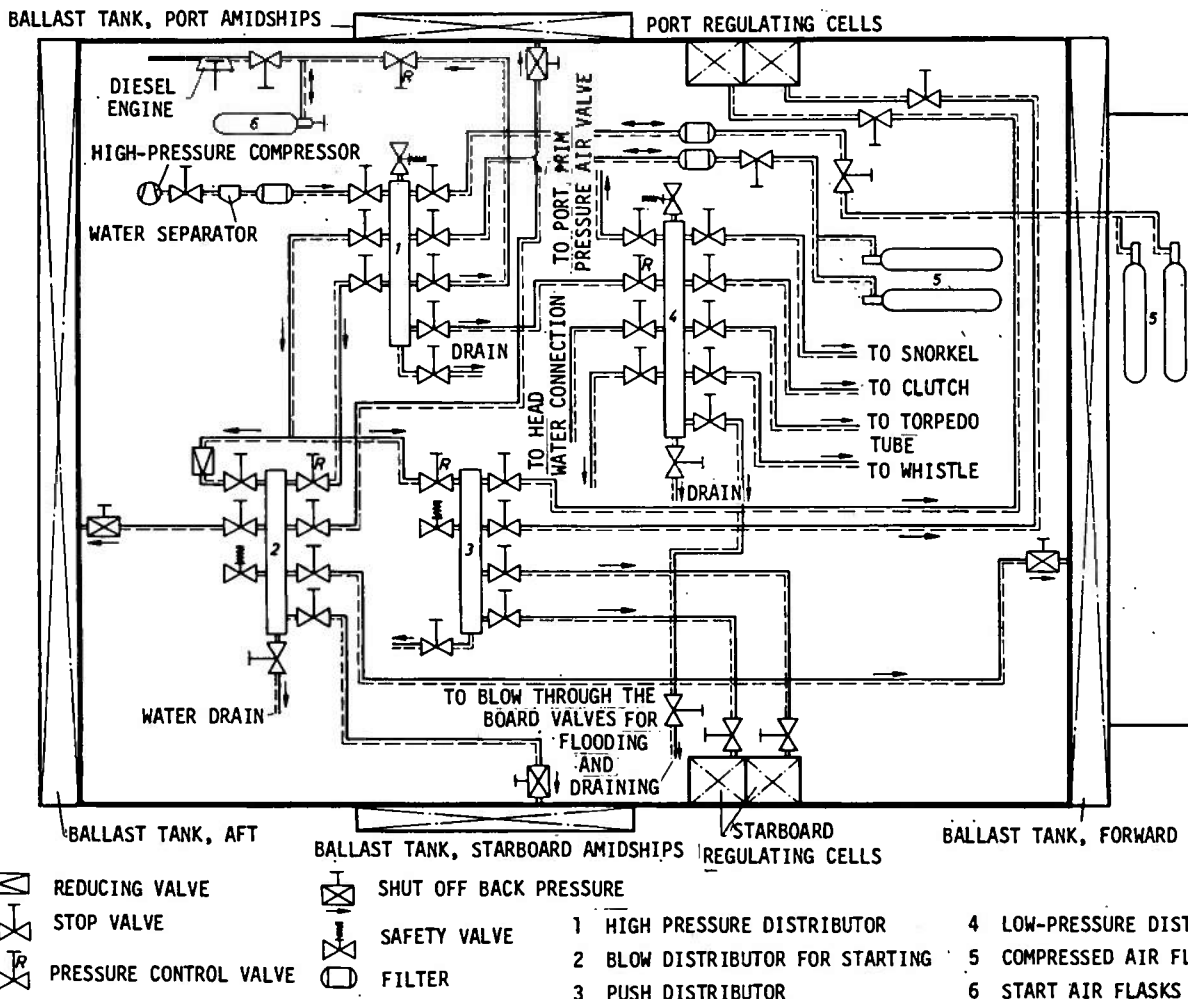

Figure 62 - Compressed Air System

HYDRAULIC OIL SYSTEM

Hydraulic oil is especially suited for the propulsion drive when the absence of noise is important and when either large forces or moments become necessary. Hydraulic oil is therefore frequently used in submarines to drive the rudder engines; in the hoists of telescoping equipment, especially periscopes; and for activating torpedo tube muzzle covers.

The advantage of a central hydraulic plant with an accumulator (Figure 63) from which all the hydraulic consumers are supplied (as compared with individual systems) is that the capacity of the hydraulic pump can be smaller than the combined power capacities of all connected consumers. (All consumers are never operated simultaneously and continuously.) Another advantage is that the rudders, the most important consumers supplied from the accumulator, can still be operated when the hydraulic pump electric drives fail temporarily, e.g., under shock.

ELECTRICAL NETWORK

The ship service electrical board network supplies the consumers of electric power. The relatively small number of major consumers, such as drain pumps, cooling pumps, compressors, blowers and alternators, are supplied from the nonstabilized board network. Certain consumers, such as the cooling pumps of the propulsion plant and the consumers of alternating current must be able to produce their full output at minimum battery voltage. All other consumers have a set minimum voltage as their nominal rating; it is usually slightly higher than the minimum battery voltage. The drive motors as well as the other drives must be able to run on maximum battery voltage.

Each consumer can be connected to one circuit of any battery. This provides for uniform battery discharge and makes a spare circuit available.

In addition, there is a stabilized board network for those direct-current consumers that require a constant voltage supply, e.g., compartment lighting, position lamps, and the intercom system. This network is frequently divided into two groups which (as above) can be connected to any battery.

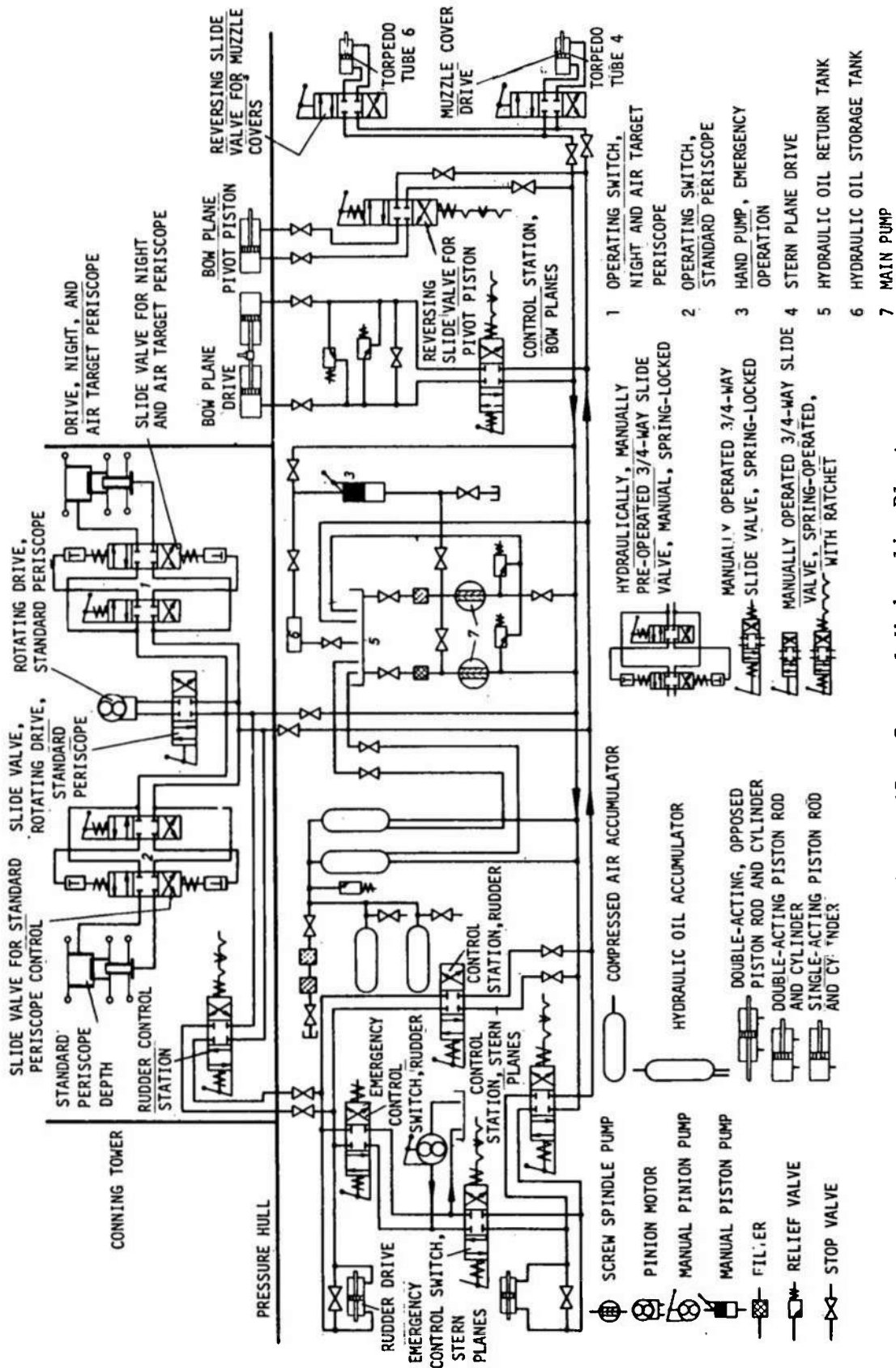

Figure 63 - Central Hydraulic Plant

Convertors produce the three-phase alternating and direct current required for the detection, communication, and fire-control systems.

ANCHOR EQUIPMENT

Submersibles are usually provided with only one anchor and one anchor chain.

A Hall anchor with shortened shaft is usually used (Figure 64). The hawse hole is designed so that the anchor is as flush as possible with the shell. The capstan, clutch, brake, and chain locker are located in the outer hull. The capstan drive is usually operated from inside the boat. Compressed air, hydraulic oil, or electric motors are used.

Mushroom-type anchors fair more easily into the shell than do Hall anchors. However, the mushroom anchor is not dependable. It does not hold well in hard soil, but once it does catch hold, it is difficult to break loose.

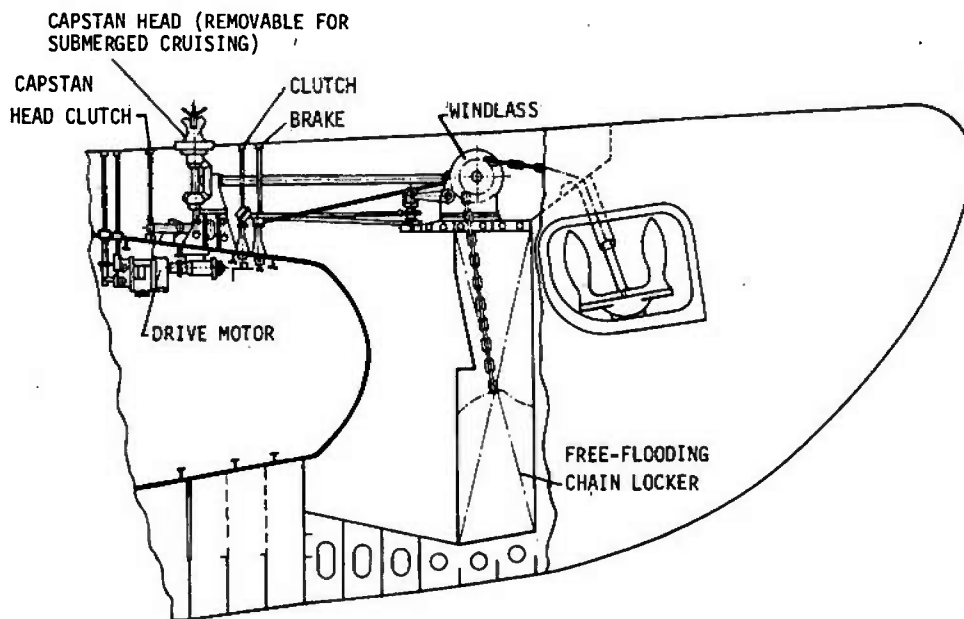

Figure 64 - Anchor Equipment

EQUIPMENT FOR TOWING AND MOORING

A front towing hook is installed under the forecastle deck for towing purposes. The towline is roved through the hawse hole to the towing hook in the free-flooding superstructure. A slip line leading from the towing hook to the bridge will permit the connection to be detached at any time.

If there is no towing hook, the towline is passed from the forward cleats to the midship superstructure and secured there. The forward cleats alone are not strong enough to take the pull of the towline.

Submersibles usually sail without guard rails in place. Crew members who have to work on the forecastle must be kept safe in some other way. One method is to install a U-shaped rail in which a shoe can slide fore and aft. A crew member can then safely move about on the deck wearing a safety belt that is connected to the shoe by a short line.

Bollards and cleats for mooring lines are distributed fore and aft as aboard surface ships of comparable dimensions. Because of the narrow deck, they are usually installed midships and the same bollards and cleats are used alternately for port or starboard mooring. Insofar as possible, retractable bollards and cleats are installed so that they will not cause drag during submerged cruising.

CHAPTER XII

NAVIGATION AND COMMUNICATION INSTALLATIONS

COMPASS INSTALLATIONS

It was not until the invention of the gyrocompass that submersibles were able to steer precisely. The master compass feeds several repeaters; for instance, those at the steering station, on the bridge for taking bearings, and those which are necessary for the radio direction finder, for different detection instruments for the fire-control system, and, among others, for the course indicator in the captain's cabin.

Submarine construction provided the incentive for the development of the gyrocompass in Germany. H. Anschütz, a member of a polar expedition, planned on using a research submarine to reach the North Pole under the ice cap. In order to have a compass for this expedition he started work on his gyrocompass in 1902. Because of the sea area in which it was to be used, the first course compass had no directional characteristics. Actually, the expedition never materialized because the submarine propulsion plant was inadequate. Anschütz developed the meridian gyrocompass later.

Large submarines often have aboard a second, less sophisticated, spare gyrocompass system without repeaters. Until World War II, projection-type magnetic compasses were also used as backup.

Magnetic compasses function under water because the earth's gravity field is present under as well as above water. These compasses were installed above the pressure hull in a nonmagnetic zone with a spheric radius of about 1 m. Image transmission into the pressure hull was accomplished by lenses and prisms, and the image was projected onto a focussing screen. Submarine magnetic compasses cannot be calibrated accurately on submersibles because of the interference caused by the heavy currents in the electrical networks and the long pressure hull.

The projection-type compasses used aboard merchant ships were developed from the type used on submarines. Here the bearing of the compass reading is projected into the wheelhouse below to the helmsman.

American nuclear submersibles use inertial navigation systems when navigating in the vicinity of the pole.

INDICATOR SYSTEMS FOR SUBMERGED CRUISING

The diving depth is measured by Bourdon gages. One instrument, as sensitive as possible and provided with a large dial, is used to indicate the periscope depth and another gage is used for a measuring range which extends from the surface to beyond the maximum diving depth. An intermediate depth gage is also used sometimes. Large, long submersibles have additional depth gages in the end compartments of the pressure hull.

Because Bourdon gages of standard construction (Figure 65) indicate the pressure differential between internal and external pressure, the reading must be corrected for atmospheric pressure. These gages can cause false conclusions in emergencies. For example, they will not indicate the true depth when a submarine has sunk to the bottom and the internal pressure has been equalized with external water pressure. On the other hand, gages installed in airtight casings will indicate true external pressure.

The so-called Papenberg depth gage was used by the German Navy for precision reading at periscope depth (Figure 66). The measurement is based on the compression of an air cushion, and so the reading on the cylindrical glass tube is not linear. The residual buoyancy of the boat associated with its floating position is plotted on this instrument in addition to the depth scale (starting with the surfaced flotation line and decreasing to zero when the upper edge of the superstructure has been reached). Moreover, the contour of the cross section of the boat are plotted with respect to the depth scale (distorted). The water level of the instrument is illuminated horizontally, and minute tendencies for attitude changes can be identified from the curvature of the meniscus before the water level in the tube rises or falls.

Trim is indicated by water levels with longer than usual legs (Figure 67). The rear leg, which is not used for reading purposes, has a much larger cross section than the front leg; thus the readings on the front leg will become proportionally greater.

In the German Navy, the glass tube of the trim indicator was installed alongside the Papenberg pressure gage in such a manner that the zero mark on the trim indicator was at the same level as the periscope depth indication on the Papenberg gage (Figure 68). This made it possible for the man in

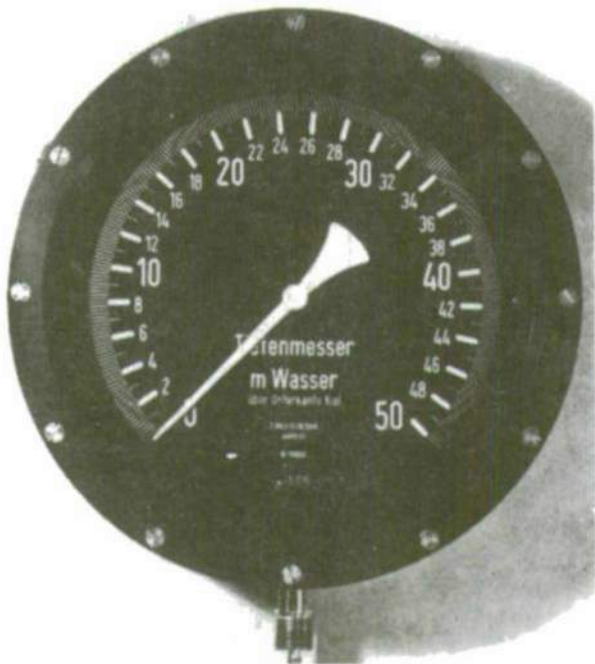

Figure 65 - Bourdon Gage Depth Indicators

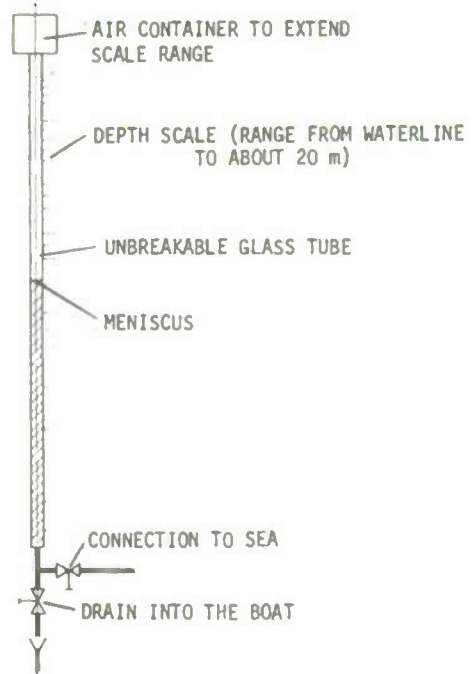

Figure 66 - Papenberg Depth Gage

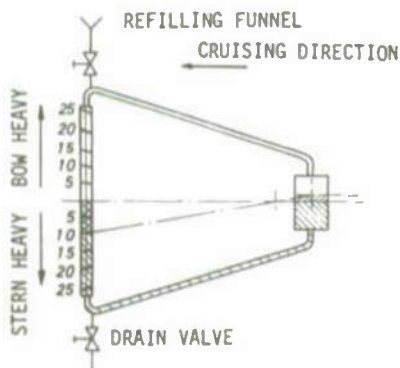

Figure 67 - Trim Indicator

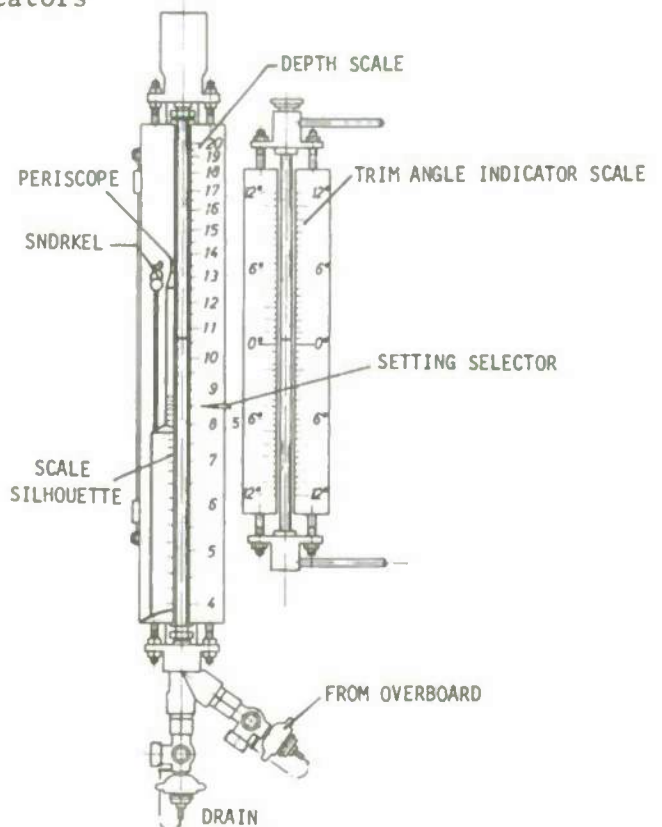



Figure 68 - Papenberg Depth Gage and Trim Indicator

charge of depth control to check depth and trim of the boat at a glance when at periscope depth, where maximum accuracy of these observations is important.

During a trim test, a pendulum is installed in the center of the submarine and is permitted to swing above a graduated plate to determine the "square" position of the boat and to adjust the trim indicator. Sea water is discharged into a tank and its density is measured with an aerometer. 

Snorkel submarines have special barometers to measure the air pressure in the submarine over a range of about ± 250 mb.

It must be possible to determine the liquid level in any tank quickly and at any time by means of special bearing instruments. For example, when tanks cannot be vented, glass gages are used to determine the level. If these cannot be installed because of lack of space, mechanical, float-controlled level indicators are used. Other tanks are fitted with sounding tubes and dip sticks. The above items can be replaced by electronic measuring devices and the indicators for all tanks can be combined on one panel in the control room.

The level in tanks in which the fuel oil floats on top of water cannot be determined accurately with simple devices.

PERISCOPE

Submarines became operational with the development of periscopes which permitted these low silhouette vessels to see above the water.

Periscopes are used for many purposes, e.g., (1) to observe shipping, (2) to observe aircraft, (3) to determine ranges for an attack, (4) to obtain target heading input for the fire-control system, (5) for terrestrial navigation when submerged, and (6) for astronomical navigation when submerged.

Periscopes must be retracted into the superstructure during deep dives and when the submarine is running at high speed. When extended, they should be free of vibration up to flank speed. Periscopes must be sufficiently extendable to leave the hull submerged deeply enough so that depth steering is not influenced by seaways during operation at periscope depth.

Periscopes consist of a cylindrical tube, 180 to 200 mm in diameter, with a polished outside surface; a conical section that is shaped like a bottle and carries the head mounted on top of the tube (Figure 69). The distance (optical length) between the objective and the eyepiece can be as much as 7 to 9 m. The periscope tube is pressure-resistant. The field of view can be pivoted about the optical axis, and several magnifications (usually 1.5 and 6) can be selected. Objects seen through the periscope at a magnification of 1.5 are about the same size as when seen with the naked eye.

Colored filters can be inserted where required. A reticule (cross-hairs) with vertical and horizontal gradations permits angles to be estimated during observations.

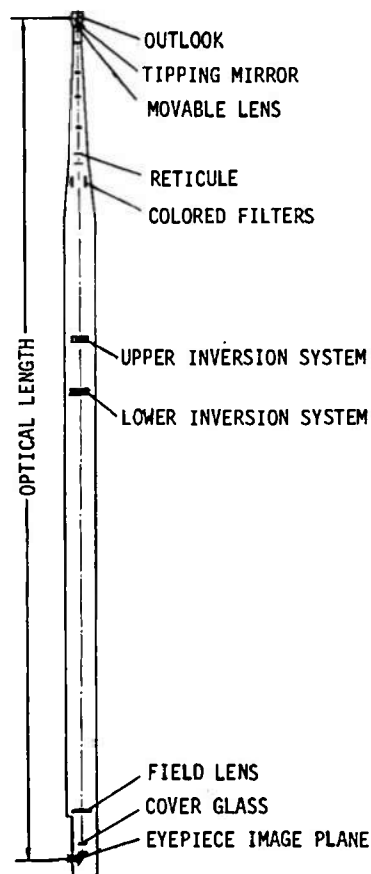
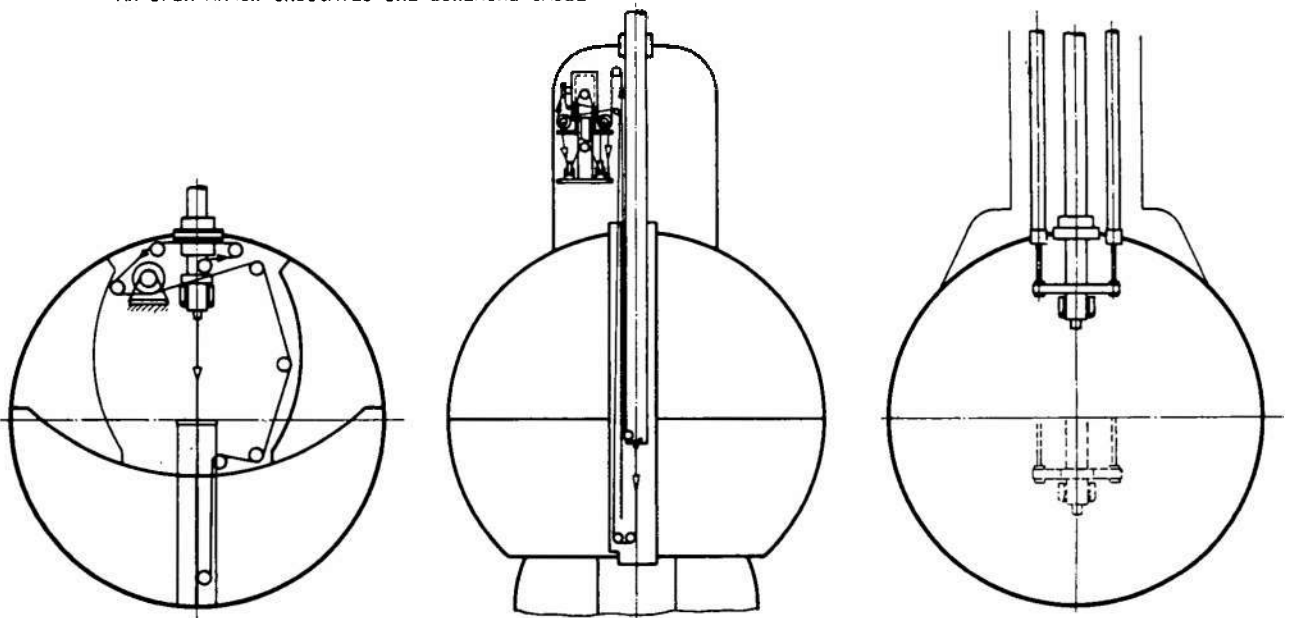

Figure 69 - Attack Periscope

Target range can be estimated from the angle at which the length (or the mast height) of the target is seen in the periscope and from the (estimated) length (or mast height). The periscope cannot be used for direct rangefinding.

The hoisting mechanism consists of two hoisting cables and one lowering cable that are operated by a common winch (Figure 70). The winch drive may be electric or hydraulic. Another way to activate the cables is by use of an inverted tackle system (multiplier) with a hydraulic piston. A third possibility is direct hoisting, by using parallel pistons hoisted and lowered hydraulically, thus eliminating the cables.

- ▶ A SOLID ARROW INDICATES TWO HOISTING CABLES
- ▶ AN OPEN ARROW INDICATES ONE LOWERING CABLE



PERISCOPE WINCH WITH CABLES FOR HOISTING AND LOWERING

INVERTED, HYDRAULICALLY OPERATED BLOCK-AND-TACKLE SYSTEM WITH CABLES FOR HOISTING AND LOWERING

HYDRAULICALLY OPERATED PISTON FOR HOISTING AND LOWERING

Figure 70 - Periscope Hoisting Systems

A special gland is installed where the periscope passes through the pressure hull (Figure 71). The periscope is guided by two or three bearings located above this gland.

In the case of the attack periscope (Application 1 and possibly 2, 3, 4, and 5 as well), it is important that the height of the head above the water be controlled and maintained at a level determined by the observer (Figure 72). This compensates for inaccuracies in depth control. Otherwise the periscope could emerge too far when depth control varies and thus betray the boat. A downward deviation in depth could submerge the head and interrupt the observation. In the case of the simple periscope, the observer at the eyepiece follows the up-and-down motion of the periscope (called a "knee-bend periscope"). The limit of the vertical lift for observations is about 1 m. The observer rotates the periscope with two handles.

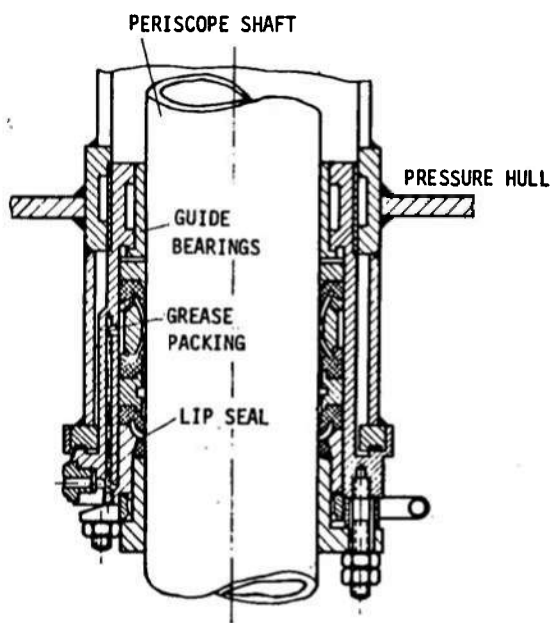

Figure 71 - Pressure Hull Penetration
for Periscope

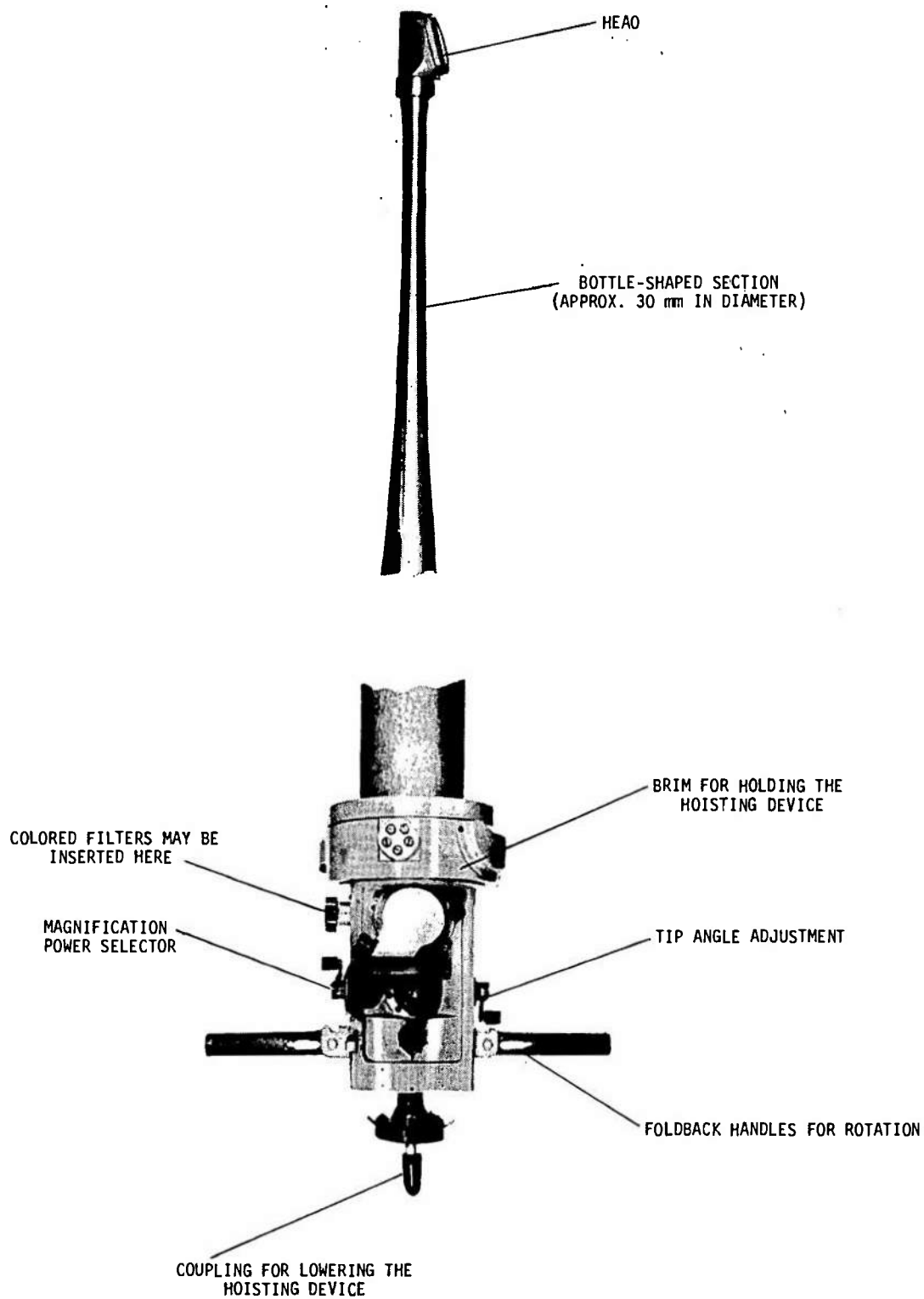

Figure 72 - External View of an Attack Periscope

In the case of the elevator periscope, which is less customary today, the observer rises and descends with the periscope.

A characteristic feature of the "standard periscope" (Figure 73) is that the insight is independent of the extended height of the periscope (this is accomplished by a double-prism inversion at the bottom of the trunk tube). The vertical lift available for observation is equal to total periscope lift. Because of its mass, the standard periscope usually has a hydraulic rotating system.

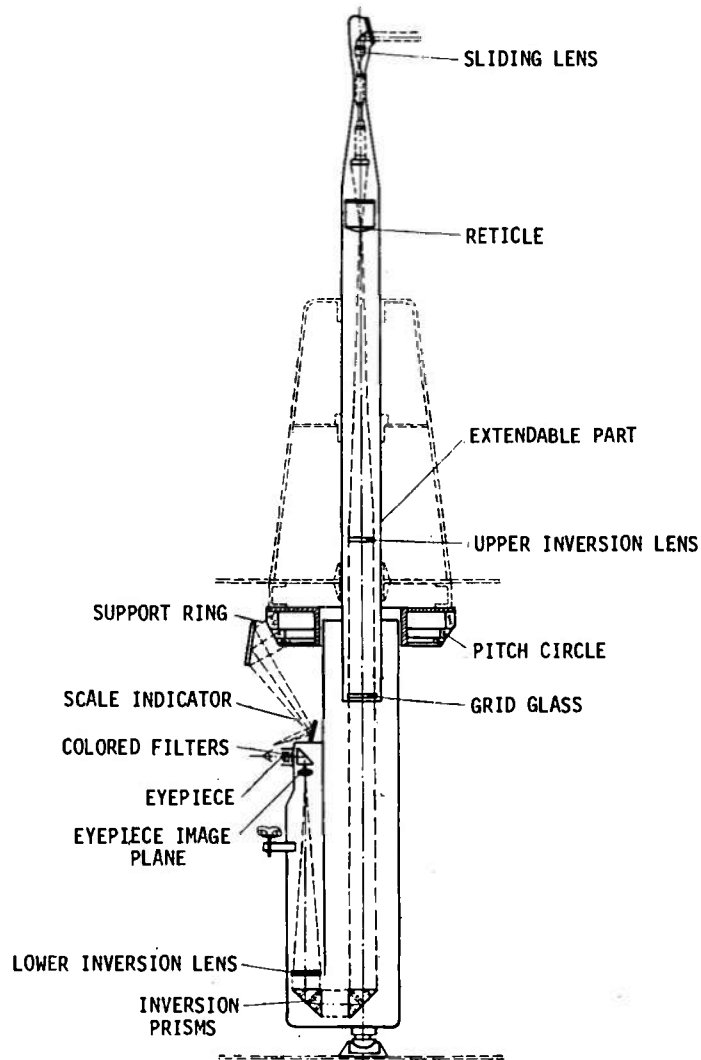

Figure 73 - Standard Periscope

The night and air target periscope (Applications 2, 5, and possibly 6) has more high-powered optics than does the attack periscope, and thus it is especially useful at twilight and in the dark. The optical tilting angle extends to the zenith. The bottle-shaped section and the head are considerably thicker than comparable elements of the attack periscope. Only simple periscopes ("knee-bend periscope) are used. A special sextant can be attached to the eyepiece to enable measurements of celestial heights while the submarine proceeds at periscope depth. A submerged submarine can use this facility to determine its position by celestial navigation.

SOUNDING DEVICES

An echo sounding device is used for depth finding; its transducer is pressure-resistant in accordance with diving pressure. When depth is to be measured directly during submerged cruising, two instruments are installed, one for upward and the other for downward sounding. The reading on the upper oscillator provides the depth from the surface and that from the lower oscillator the distance between the keel and the bottom. The sum of both readings yields the depth of the water.

This system can have an additional device for continuous recording of the readings. These recordings provide good monitoring during exercises.

SPEED MEASURING SYSTEMS

The stern hydrodynamic log is suitable for submarines because it has no parts that protrude beyond the shell and requires no openings in the pressure hull other than those for two permanently installed tubes. The system inputs are (1) the total pressure (dynamic head plus depth pressure) from the static tube in the stern and (2) the depth pressure (static head) from the port and starboard measuring tubes. The depth pressure is canceled out and the speed is indicated by the dynamic head, which is proportional to the square of the speed. The distance covered is then determined from this readout by integration.

The extendable bottom log is based on the same principle but cannot be used in submarines because of its moving parts

Where accurate measurement of the distance covered is more important than a direct measurement of the ship speed, it is preferable to use equipment that will measure the distance covered directly by counting the revolutions of an impeller. The speed is then determined from these measurements. One advantage of this system is that the depth pressure is not superimposed on the reading, as it is in the case of the stern log. The impeller has to be extended on a shaft far enough from the shell to be outside the boundary layer in undisturbed water. This requires a relatively elaborate installation in the outer hull.

ALARM SYSTEMS WITHIN THE BOAT

The general alarm facilities trigger bell or horn signals in every compartment, e.g., to announce a crash dive. Flashing light signals are also provided in compartments with high noise levels (enginerooms). The helmsman usually activates the alarm facilities.

Flow lights on a panel in the control room indicate the status of all major closures such as snorkel air intake head valves, external exhaust valves, etc. The submarine must not dive when any one of these major closures is open.

In submarines with vents that are activated hydraulically or by compressed air, the closure status of the ballast tank vents is indicated in the control room so that these systems can be supervised for proper functioning.

RADIO DIRECTION FINDER (RDF)

The radio direction finder (RDF) can be used to fix position when the submarine is running in the surfaced condition. Moreover, RDF is used to obtain bearings on radio signals of enemy or friendly forces. When rotating loop antennas are used, they must be retractable and pressure-resistant. Goniometer RDF sets have a nonrotating antenna which can be installed permanently inside the superstructure, but in that case, the superstructure must have nonconducting material within a certain distance of the installation.

Because the magnetic component of ultralong waves (12,000 to 20,000 m) will penetrate water, a submerged submarine can take bearings on ultralong

wave transmitters. Maximum reception depth for the antenna varies between 5 m and 30 m below the surface; the actual maximum depth will depend on transmitter output and the sea area. Reception of ultralong waves makes the RDF an important aid to navigation during submerged operation.

TELECOMMUNICATION SYSTEMS

So far as hardware is concerned, the telecommunication systems do not differ greatly from those installed in other comparable ships. However, the antennas require special construction. Submarines cruising on the surface can use wire antennas for transmitting and receiving. These extend from the superstructure to the deck at an oblique angle. For submerged cruising, all submarines require a rod antenna which can be extended above the surface when the submarine is at periscope depth (Figure 74). Transmission and reception are possible on the usual frequencies. Ultralong waves can be received by the RDF antenna when completely submerged. Transmitters cannot be used when completely submerged.

UNDERWATER TELEGRAPHY

Underwater telegraphy can be used for communication between submerged submarines and surface ships. These systems operate on the acoustic principle. Transducers are installed in the hull to act as transmitters and receivers. These transducers resemble those used with echo sounding devices.

These systems are used primarily during exercises to provide communication between the accompanying safety vessel and the submerged submarine. They have no tactical significance because the wireless connection can be monitored by third parties.

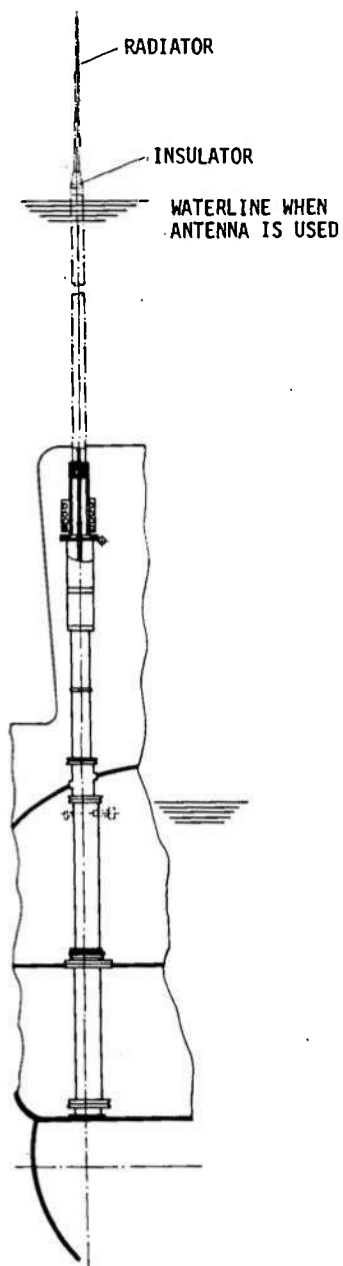

Figure 74 - Retractable
Rod Antenna

CHAPTER XIII

CREW HABITABILITY

ACCOMMODATIONS

Crew accommodations depend greatly on the size of the submarine, its employment, and its operational area. If possible, there should be one bunk (positioned in the longitudinal direction) and one locker for each man together with an adequate number of tables and seats. The captain, officers, senior petty officers, petty officers, and nonrated men are given separate accommodations when space permits. The captain and the officers should be accommodated as close to the control room as possible. Large submarines usually have separated spaces for messes, washrooms, and showers. Space can be so limited in the smaller submarines that the number of bunks will accommodate only two-thirds of the crew, and some bunks must be shared by the different watches.

PROVISIONS

Because perishable food will not last long in submarines, most of the provisions are in the form of canned food, bread baked in foil, dehydrated potatoes, dried peas, beans, rice, etc. The refrigerator, usually small but almost always available, is used to store fresh meat which is consumed early in a cruise. Only the large submarines have adequate refrigeration to accommodate a supply of meat, fish, vegetables, and potatoes for an entire cruise. In most cases it is impossible to find space for all provisions in the storerooms and some, particularly the canned goods, must be stored elsewhere. The effect of food consumption on trim must be considered when provisions are stowed.

FRESH WATER

The amount of fresh water storage has a direct bearing on the size of the trim tanks. Consequently, in order to have small size water tanks it is advisable for large boats with long cruising lines to have plants for distilling fresh water from sea water. These plants are operated on electric

power. Because of the efficiency with which electric power can be generated, diesel fuel consumption to make fresh water is approximately one-ninth the volume of the fresh water distilled.

The submarine is therefore heavier when fresh water consumption is produced by distilling plants. This continuous generation of extra weight compensates in part for the reduction in weight that results as provisions and fuel are consumed. Thus, the trim capability needed will be reduced as desired and trim tanks can be made appropriately smaller. The change in trim caused by fresh water consumption must be taken into consideration when arranging the fresh water tanks.

WASH WATER

Special wash water tanks are provided only in large submarines. The torpedo tanks can be filled with wash water in all cases, but it will be contaminated by trim and torpedo tube water when the first torpedo is fired.

Special salt water soap is provided to enable sea water to be used for washing.

GALLEY FACILITIES

Special significance is given to high-quality galley facilities in submarines; recreation or diversion after tedious hours on watch is rare during long missions and thus a wide variety of well-prepared meals is an important factor in maintaining crew combat readiness.

All galley equipment is electrical, including facilities for frying and baking. The galley is usually used during snorkel cruising not only because power is generated directly during this time but also because the resulting steam and odors are exhausted by the diesel engines. All pots must be designed as pressure cookers (Papin principle), otherwise the fluctuating pressure (which is always present during snorkel cruising) would prevent the proper cooking of food, such as dried peas and beans, and the pots would boil over frequently.

Garbage is ejected outboard through a lock (by using compressed air or compressed water). Empty cans must be pressed flat to prevent their floating to the surface. A can compressor device is used for this purpose (it is noiseless so that it can be used during low-noise cruising).

SANITARY FACILITIES

The waste collected from the heads accumulates in a pressure-resistant tank which can be ejected by compressed air (Figure 75). The capacity of this waste tank is sufficient for about 24 hr. It is strong enough to be ejected at any depth.

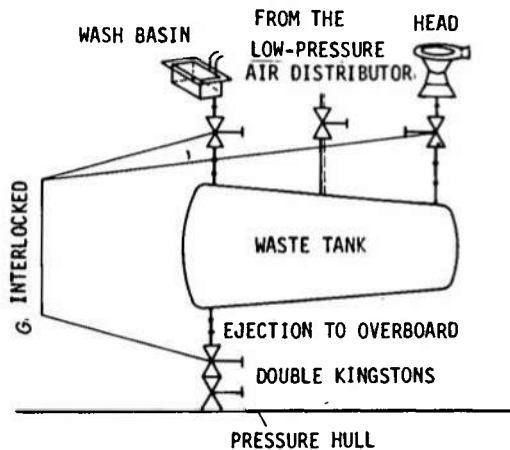

Figure 75 - A Head System

Night snorkel cruising is very well suited to this ejection operation because the air bubbles are invisible, the compressed air consumption is lower because of the shallow depth, and the ejection noise cannot be heard because it is obliterated by the engine noise generated during snorkel cruising.

The pump-type head formerly used when submerged was similar in design to that used aboard yachts. The disadvantage that any pumping operation will restrict the diving readiness of the submarine is greater than the advantage of smaller space and weight offered by such an arrangement.

VENTILATION SYSTEM

The ventilation system is used to ventilate the submarine and circulate the air during surface and snorkel cruising. An air supply and an air exhaust line are installed the length of the submarine (Figures 76 and 77). The blowers are single- or dual-stage fans with electric drive designed for low-noise operation. Air is taken in and exhausted through air supply and exhaust masts with pressure-resistant head and foot valves.

The valve heads open against water pressure and have rubber gaskets; they are located at the highest point in the superstructure. The masts are fitted with water separators.

Submarines usually have larger blowers than submersibles because ventilation must take place as rapidly as possible after surfacing. The submersible ventilates while cruising on snorkel. The time required for an air exchange depends on the amount of air required for the diesel engines. Each blower in a submarine exchanges the air about 20 times/hr.

Most German submarines also ventilated the battery with the ventilation exhaust system. Foreign ships have often a special battery ventilator for this purpose.

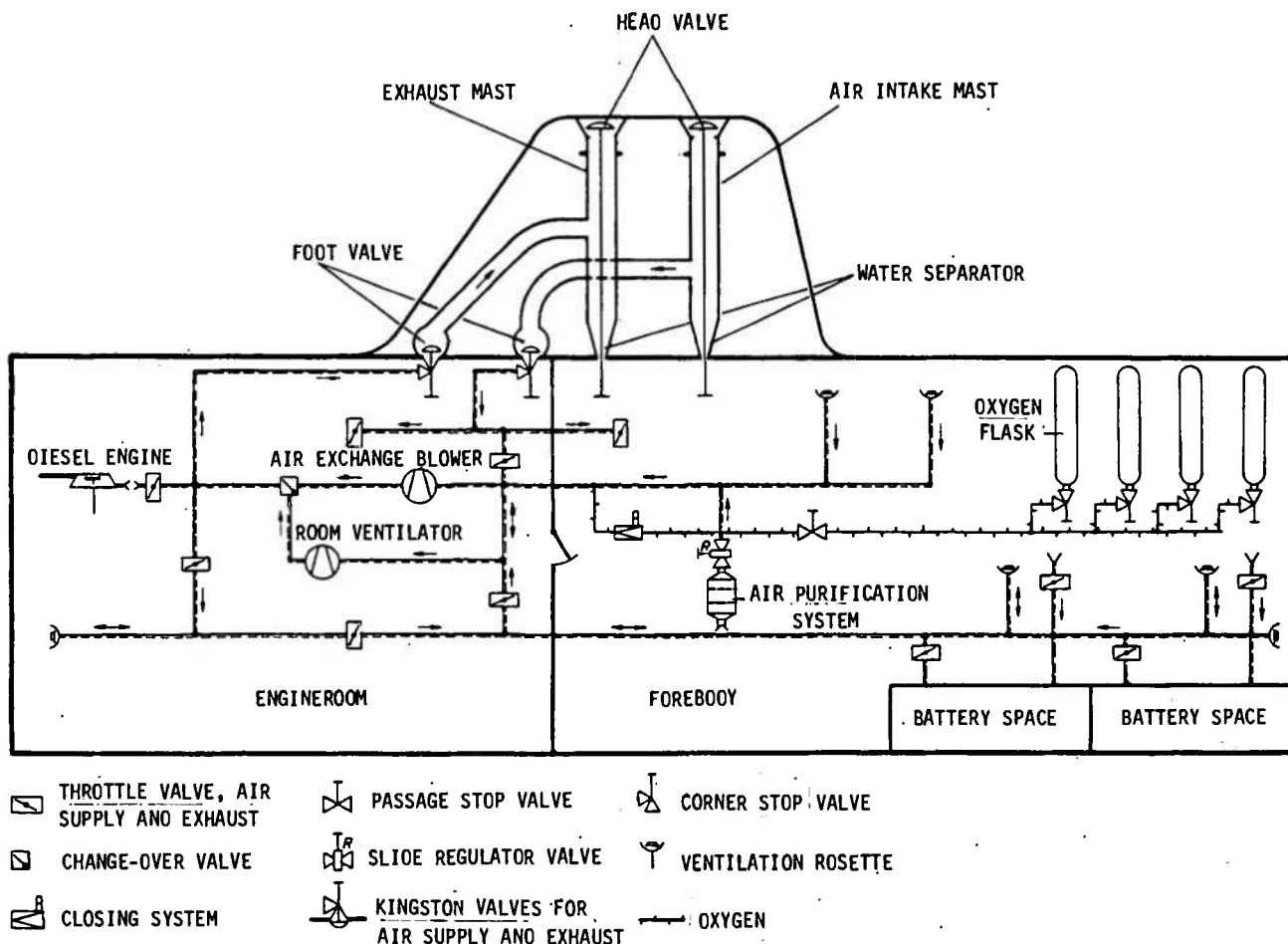
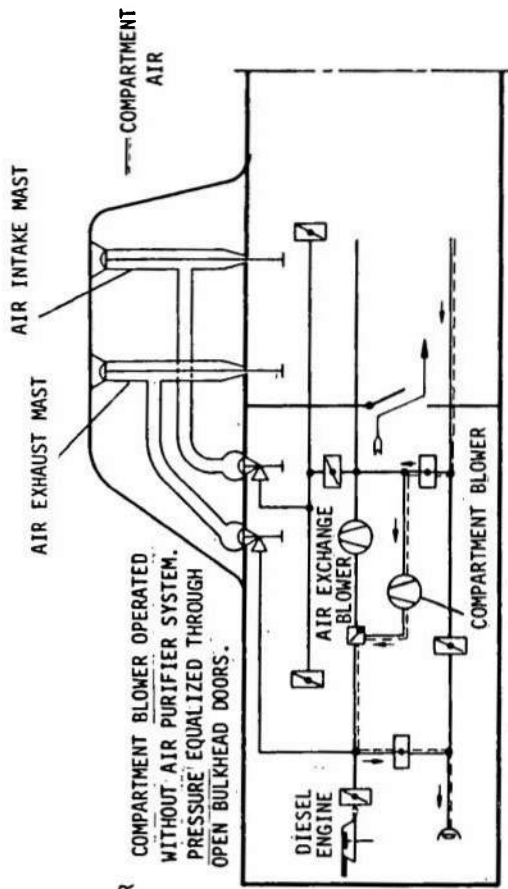
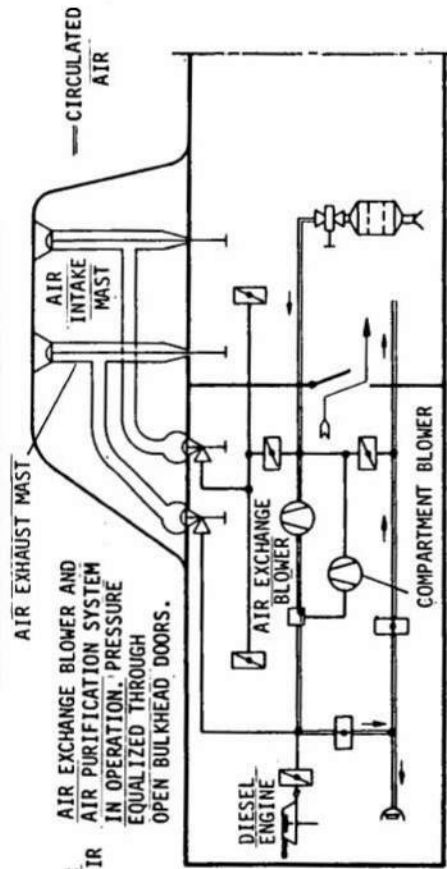

Figure 76 - A Ventilating and Air Circulating System



AIR CIRCULATION DURING SUBMERGED CRUISING



AIR CIRCULATION DURING SUBMERGED CRUISING WITH AIR PURIFIER SYSTEM

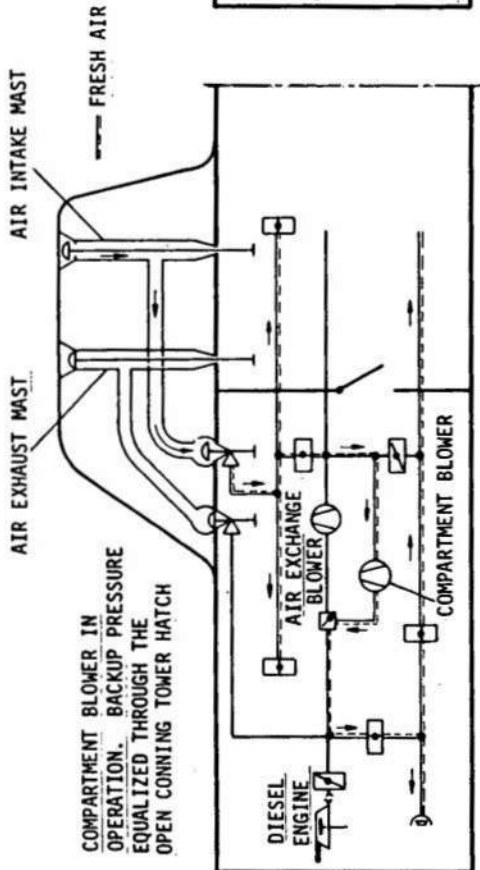

VENTILATION DURING SURFACE CRUISING

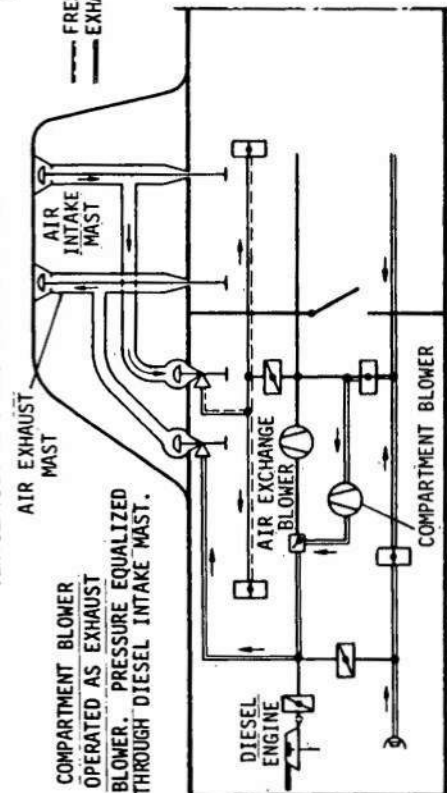

VENTILATION DURING SURFACE CRUISING WITH BATTERIES CHARGING

Figure 77 - Ventilation Methods

When the exhaust system is used to ventilate the battery, the line must be acid-resistant (have a lead liner, for example), and the blower must be explosion-proof.

Air is circulated during submerged cruising, and the air purification system can be connected to the ventilation system. In addition, the exhaust system is used to check for leaks prior to diving (negative pressure test).

Prior to a test dive, the exhaust blower is used to subject the boat to negative pressure. The air exhaust mast is sealed off and then the exhaust blower is shut down. The negative pressure level is observed for a period of about 2 min. If the level remains approximately constant, it is concluded that all major openings are closed, that air is not entering the submarine from the compressed air system.

The relative humidity can be almost 100 percent in submarines that cruise submerged for extended periods in tropical waters. It is important to reduce this humidity by a dehumidifier to provide for crew comfort and the proper operation of many electronic systems. This system will cool the air a few degrees. The resulting condensate can be used as wash water. Operation of the dehumidifier is useless during surface and snorkel cruising because of the frequent air exchange.

AIR PURIFICATION SYSTEM

During continuous submerged cruising, the air must be purified by chemically removing the carbon dioxide (CO_2) produced by respiration and replacing the oxygen (O_2) consumed.

The amount of CO_2 in the air breathed should not exceed 2.4 percent. A concentration of 4 percent will have a severely adverse effect on crew efficiency, and 5 percent will be toxic.

The oxygen content, 20 percent in fresh air, should not fall below about 15 percent. Such factors as crew activities and the available air space per man determine when the air purification system must be started.

The following are the approximate air space/man relationships in German World War II submarines (see the Appendix for descriptions of the various types):

Type 2d:	7.5 m ³
Type 7c:	10.5 m ³
Type 9:	11.5 m ³
Type 21:	17.0 m ³
Type 23:	8.5 m ³

One man aboard a submarine will generate about 22.5 liters of CO₂/hr. His O₂ consumption averages about 22.5 liters/hr.

A man requires about 0.5 liter of air per inhalation. Respiratory frequencies are 22 inhalations/min while standing up, 19 while sitting down, 13 while lying down, and 10 while sleeping. The mean oxygen consumption of 22.5 liters/hr cited above corresponds to 15 inhalations/min. During extended submerged cruising, therefore, the men on duty should sit down whenever possible and men off watch should rest.

Carbon Dioxide Absorbent System

Chemical absorption by using sodium hydroxide is:

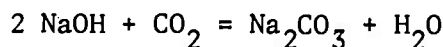

and by potassium hydroxide is:

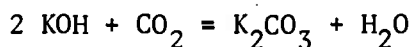

Sodium hydroxide is contained in cartridges, potassium hydroxide in storage cans. The cartridges intended for consumption are inserted in racks. The potassium hydroxide is poured from the cans into a container. The air circulated during submerged cruising flows over the rack or through the container and absorbs the CO₂.

Heat will evolve as a result of CO₂ absorption. Recooling is an indication that the process has terminated. The used material can be disposed of through the waste disposal lock.

The supplies carried for air purification are consumables and, as such, are included in the weight calculation. When continuous submerged operation is planned, their weight is about the same as that of the provisions.

Oxygen Replenishment System

The oxygen supply is carried in gaseous form in oxygen flasks or in chemical form in cartridges. The pressure flasks (content about 50 liters each at a pressure of 150 to 200 atm) are connected in banks. Oxygen is added through a simple metering device installed in the ventilation line that distributes the oxygen throughout the submarine. For oxygen consumption, the cartridges are installed in the control room in a simple apparatus and discharge the gas free into the compartment by evolving heat in the process.

Oxygen in flasks can be metered more precisely than oxygen in cartridges and metering can be stopped at any time. However once an oxygen cartridge has been started, it must be discharged completely otherwise it will create the danger of over-enrichment with oxygen. Spontaneous combustion, e.g., of fabric, is possible when the oxygen level is too high.

On the other hand, oxygen cartridges require less storage space, and, within certain limits, the total number of cartridges carried can be adapted to the tactical requirements of a specific submarine.

HEATING SYSTEM

Portable electric heaters are the primary source of heat in port as well as during surface and submerged cruising. In addition, during submerged cruising over a long period of time, the heat evolved by the propulsion system, the auxiliary engines, and the electronic equipment can be used to heat the submarine through the ventilating system. Moreover, (1) compartment dehumidifier plants can be connected so that it can be used as a heat pump when needed or (2) the thermal heat in the surrounding sea water can be used to heat the air inside the boat.

CHAPTER XIV

SAFETY AND RESCUE FACILITIES

SAFETY FACILITIES

The condition of submarines during surface cruising differs from that of other ships in that submarines have much less residual buoyancy (reserve displacement).

The seakeeping characteristics of a submarine on the surface correspond approximately to those of a small, overloaded cargo vessel; even a small leak can cause sinking. Accordingly, for safety reasons, the ballast tanks must be blown from time to time when surfacing. The conning tower hatch must be ready for closing at all times. Draft must be checked constantly in port, and the condition of the bilges must be inspected.

Only in large submarines is it possible to provide watertight transverse subdivisions in order to preserve buoyancy even when one compartment and the adjacent ballast tank are flooded.

Double-hull submarines are better protected against pressure hull damage from ram impact than are single-hull submarines.

Because of their strong pressure hull and keel construction, submarines are less likely to spring leaks when they run aground than are other ships.

The compressed air supply is the most important safety feature in the event that a submarine should spring a leak when submerged. Efforts are made to reach the surface as rapidly as possible by blowing ballast tanks, by accelerating to maximum speed, and by setting the depth planes at maximum rise angle.

Additional buoyancy can be obtained rapidly by dropping a detachable safety keel. However, this design was abandoned in Germany long ago because of the cost and the reduction in stability when the keel is dropped.

If a submarine fails to reach the surface, it will sink to the bottom. If it has pressure-resistant transverse bulkheads, attempts can be made to localize the leak. The pressure in the compartment associated with the leak will equalize with the outboard pressure. The air above the leak will form an air bubble in the upper part of the damaged compartment.

The following approximate quantities of water will enter through a leak of 1 cm^2 in area:

At 2 m:	$1.5 \text{ m}^3/\text{hr}$
At 20 m:	$5.0 \text{ m}^3/\text{hr}$
At 100 m:	$10.5 \text{ m}^3/\text{hr}$
At 200 m:	$14.5 \text{ m}^3/\text{hr}$

A submarine on the bottom in moderate depths can release signal buoys which either remain connected to the submarine and are later used for communications (telephone or morse code) or rise freely to produce light, smoke, or radio signals.

RESCUE FACILITIES

The crew can take to pneumatic boats in the event of an accident while cruising on the surface. Today these boats are frequently designed as rescue islands; they are covered with a canopy and are capable of carrying up to 20 men. There are, in addition, life jackets or aqualungs. Life buoys are provided to aid men who may fall overboard. These are ring or horseshoe shaped depending on the shape of the conning tower hatch.

If an accident occurs during submerged cruising, the crew can be rescued only if the depth is not too great. The best prospect for success is the method whereby the men pass through a special hatch in turn and float to the surface.

Submarines with pressure-resistant transverse bulkheads have rescue areas where the crew can assemble. This space is flooded in order to allow the hatch cover to open. When released, the hatch cover opens automatically as a result of the head of air built up under it. The coaming of a hatch built as an emergency exit extends down into the submarine far enough to form an air lock which traps a large air bubble within the hatch coaming after the hatch cover has been opened (Figure 78). This air lock can be a permanent installation, or it can be portable and lowered before the compartment is flooded.

As the compartment is flooded, the crew assemble around the hatch so they can breathe in the remaining air bubble. In an emergency, the crew can also use the aqualungs provided for every man aboard (Figure 79). The

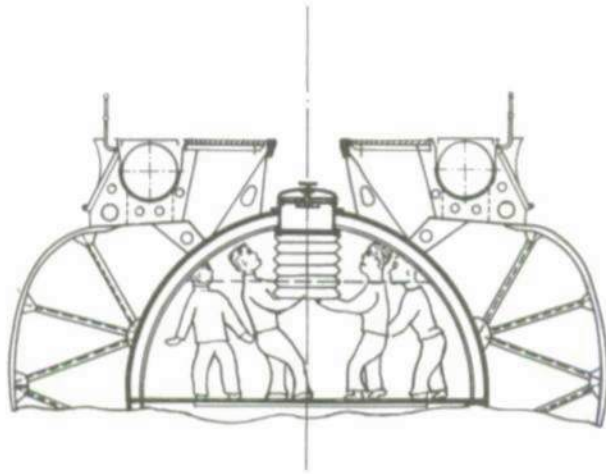

Figure 78 - Hatch with Air Trap



Figure 79 - Aqualung

aqualung is a breathing bag system that uses an alkali cartridge to remove the CO_2 from the exhaled air; at the same time, it enriches the respiratory air with oxygen. On the surface, the aqualung serves as a life vest.

Individual aqualungs can be replaced by a central emergency breathing system that provides a mouthpiece for each man in the vicinity of the emergency hatch and is supplied with air by a feeder line.

His life vest will enable an individual to float to the surface without using a breathing device. A safe free ascent is possible from a depth of 60 m. There are known cases where men have floated up from as deep as 90 or 100 m.

Men who float up from a sunken submarine must depend on a rescue ship for pickup unless the submarine carries a rescue island that can be released to float to the surface. In that event, the crew need not await the arrival of outside rescue forces before abandoning ship. The island will inflate on reaching the surface, and it is connected to the submarine by a long line.

Foreign submarines are often fitted with rescue locks connected to the rescue assembly areas. The rescue assembly space is not completely flooded and the locks permit the crew to abandon ship in two's or three's. The danger in this type of system is that the remaining men will be sealed in should trouble develop in the lock.

When submarines do not have pressure-resistant subdivisions, the crew can abandon ship by the same principle as used for the rescue assembly space. One difference is that in most instances, the pressure is equalized immediately after the accident and thus it is not necessary to flood before abandoning ship. A flooded submarine must be abandoned as soon as possible because prolonged exposure to pressure will decrease the chances for survival after rising to the surface. Moreover chlorine gas will evolve in the boat when the batteries flood.

The hatch cover must be held down by a special safety line until ready for complete release. When the line is released, the hatch opens automatically as a result of the air pressure below it.

If the hatch cover were released without using the safety line, it would open abruptly and oscillate rapidly, thus endangering the man assigned to release the hatch cover.

Another rescue method involves a pressure-resistant diving bell (Figure 80) that can accommodate about 10 men. The emergency assembly area is not flooded and remains under atmospheric pressure. The bell is lowered into the water from a rescue ship located above the sunken submarine. A diver secures a line to the submarine in the center of the hatch to be used for the rescue operation. The free end of the line is led to the winch in the diving bell. This winch, manned by a crew of two or three and operated by compressed air, lowers the diving bell onto the hatch of the sunken submarine. The hatch has an outer flange that fits the diving bell. When the bell has been secured and the space between the bell and submarine has been evacuated by compressed air, the hatch in the bottom of the bell can be opened and then the hatch of the submarine. Once the men are in the bell, the hatches are closed, the bell separates from the submarine, and rises to the surface. The rescued men leave the bell through its upper hatch. This process is repeated as many times as required. One advantage of this method is that the crew is not exposed to pressure during the rescue operation. Rescue is possible at depths within reach of professional divers.

However, the success of a rescue operation depends on many random factors. The damaged submarine must be found quickly, the rescue ship with the diving bell must be available on short notice, and the weather must permit the rescue ship to anchor above the submarine. It must be possible for the rescue crew to exchange information with the men in the submarine. The diving bell cannot be attached to the submarine if the angle of the submarine on the bottom is too steep.

A diving bell was instrumental in rescuing 33 survivors of the U. S. submarine SQUALUS from a depth of 73 m in 1939.

In a more recent design, the first connection between the sunken submarine and the diving bell is established by means of a buoy which the submarine floats to the surface and which carries a line that is rove through a block attached to the center of the hatch on the submarine. This line makes the initial connection to the bell and so the assistance of a diver is not required.

Because attempts to raise sunken submarines together with their sealed-in crews are rarely successful in time to save the men, modern submarines no longer have special hoisting hooks.

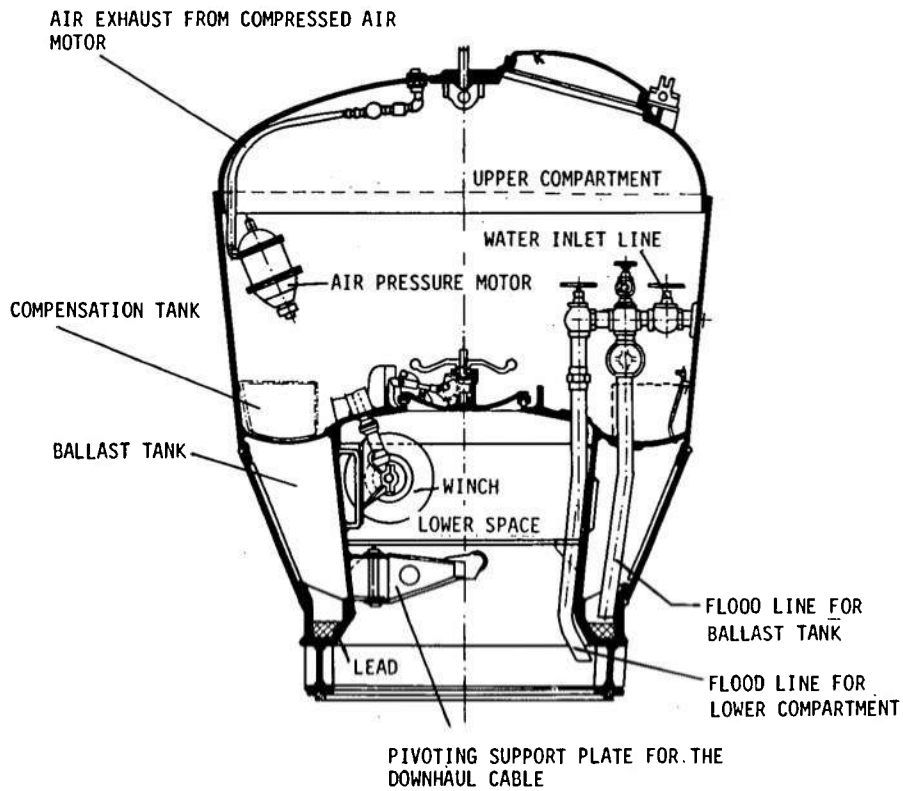

Figure 80 - Diving Bell for Submarine Crew Rescue

CHAPTER XV

DESIGN

SPECIFICATIONS

Contractee specifications must be available before design work can begin on a new type of submarine. Specifications should include requirements, desirable features, and factual information.

The type to be designed must meet the requirements specified, e.g., for a certain type of armament and its associated weapon control system, maximum surface and submerged speeds, surface and submerged cruising ranges at certain speeds, maximum submersion, submerged endurance, and other characteristics. Also included are such dimensions and characteristics as draft limitations (based on port conditions) or the requirement not to exceed a certain standard displacement (possibly with a view to international commitments). Moreover, the contractor can set a maximum cost and stipulate certain construction deadlines.

Whenever possible, excessively detailed requirements should be avoided. If the requirements imposed in some individual areas are too specific and detailed, they frequently result in but one possible design solution. Although this facilitates the designer's task, it will prevent him from contributing to the problem, e.g., by proposing a quite different and as yet unknown approach.

If the contractee sets a maximum depth, for example, and at the same time specifies the type of steel for the pressure hull, he has clearly determined an essential part of the deadweight as well as part of the required safety factor used for collapse depth (because of technological reasons, each type of steel has a different factor). On the other hand, if the designer is permitted to select the material, he can exploit new developments in the materials area and possibly use any resultant weight reduction to incorporate other desirable features in the design.

Similar considerations apply to propulsion systems. These should be stipulated only when the contractee must select a certain type of engine for reasons of maintenance and spare parts management. In all other cases, it is better not to name the type of propulsion system in the specifications.

Desirable characteristics should make up the greatest part of the specifications. The designer must attempt to incorporate them, whenever possible, within the scope of a harmonious, overall design.

One of the specifications may stipulate, for example, that speed and cruising ranges beyond those set forth in mandatory characteristics are desirable. Moreover, the desirable characteristics can refer to such general submarine features as low detection factor (absence of noise, low favorable silhouette during surface and submerged cruising), and stability and endurance during submerged cruising.

The specifications should convey to the naval architect a picture of the contemplated classification of the submarine type within the overall Fleet building program. The designer must also be informed of experience acquired in the operation and maintenance of earlier in-service types.

All of this information is the starting point for the designer, who must find the optimum tradeoff for a submarine representing a "weapon system."

DEVELOPMENT OF A DESIGN TYPE

Type characteristics must be established first. In most cases, the specifications will determine whether a true submarine, a submersible, or an intermediate type will be feasible for the required mission. The external configuration must be selected accordingly (see Figures 5, 6, and 9).

The first task is to determine whether the design should incorporate a single hull, a double hull, or a combination of the two. The governing factor in this choice is the ratio of the combined volume of fuel and ballast tanks to the submerged displacement. If this ratio is small, a single hull will be best, but if it is large, a double hull will be the solution. A combination of the best features may be advisable for an average ratio.

In the case of the double-hull configuration (Item a on Figure 81), the pressure hull is completely enclosed by a second envelope, the outer hull. The space between the pressure hull and the outer hull includes the ballast tanks, the fuel tanks, and the free-flooding spaces.

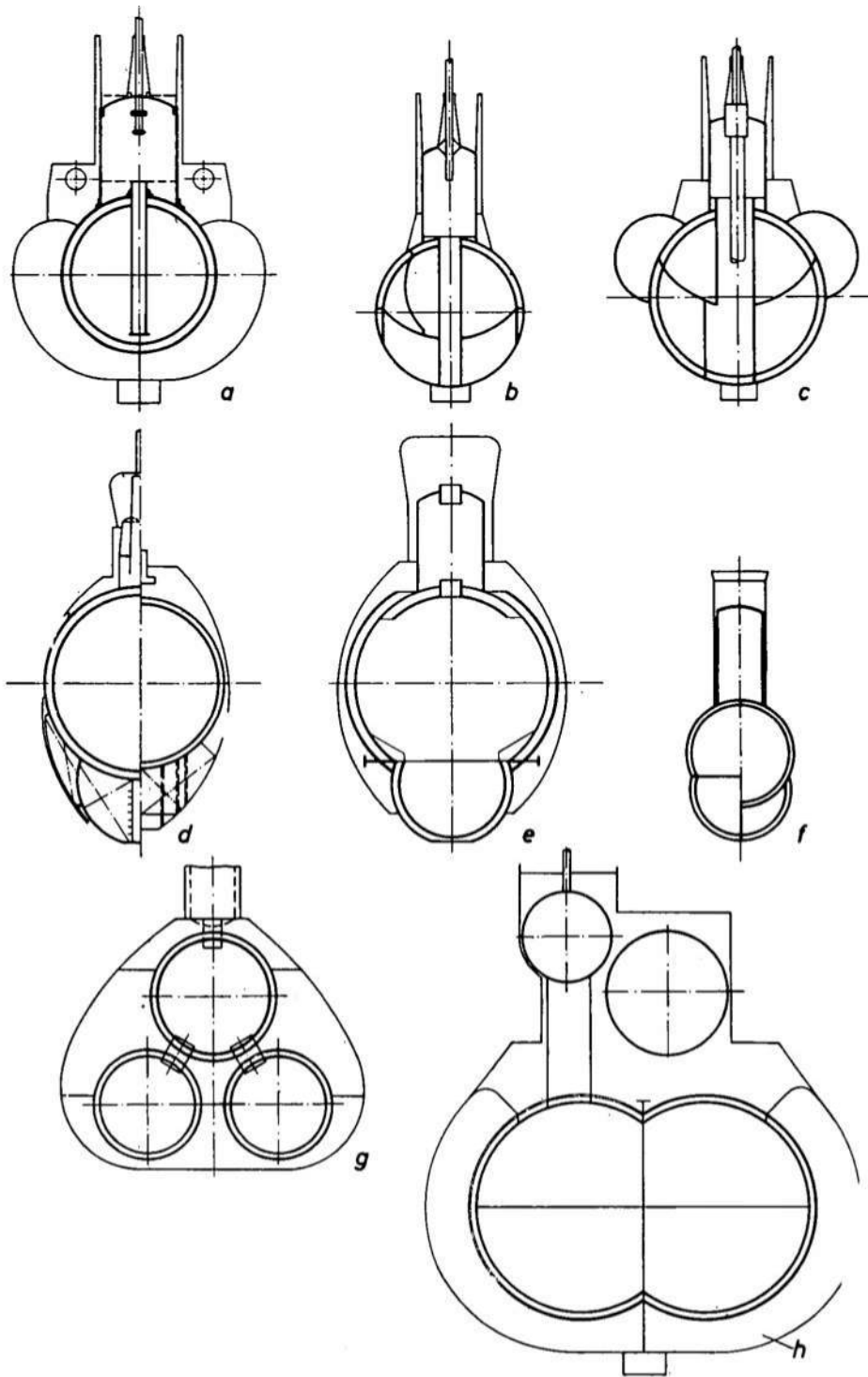

Figure 81 - Hull Cross Sections

On single-hull boats (Item b, Figure 81), which are no longer built in their pure form, small outer envelopes are installed over the ends of the conical parts of the pressure hull.

In the case of a combination of double- and single-hull boats (Item c, Figure 81), saddle tanks are installed athwartships and can contribute greatly to surface stability. These saddle tanks can serve as ballast tanks, fuel tanks, and, if pressure-resistant, even as compensating tanks and negative tanks.

When the Walter propulsion system is used, fuel can be stowed in the outer hull, below the pressure hull (Item d, Figure 81).

Many factors, such as space utilization, submerged and surface stability, and strength, have an effect on the pressure hull cross section to be selected. The desirable configuration is a pressure hull with circular cross sections.

If a boat has large batteries, it may be necessary to locate them on two levels, one above the other. In such case, the pressure hull cross section resembles an upright figure eight. Item e of Figure 81 is for a large double-hull submarine with such a cross section to accommodate the size of the battery (German Type 21, 1944). Item f is for a small, single-hull type (German Type 23, 1944).

When a great deal of deck space is required for the batteries and propulsion machinery, another solution is that shown in Item g of Figure 81 (Dutch boat of the DOLPHIN class, 1959). Here the pressure hull is subdivided into three parallel cylinders in close proximity. The two lower pressure hulls contain the propulsion system and the upper one the ship control and detection systems, armament, and crew accommodations. These cylinders are enclosed by the lightweight outer hull.

The pressure hull can be constructed in the form of a lazy figure eight when draft limitations are imposed on very large submarines or where space considerations require such solution. Item h of Figure 81 is for a Japanese type, 1944.

Any pressure hull with less than a completely circular cross section requires heavy supporting decks and/or bulkheads between the buckling edges.

The length and longitudinal subdivision of the pressure hull are determined by length requirements and by rational arrangement of armament,

propulsion system, ship control, communication, and detection systems as well as by various other shipboard installations.

An early decision must be made as to whether a pressure-resistant conning tower will be required or whether a simple access trunk will suffice. This decision depends primarily on the required retraction length of the periscopes. When the pressure hull has a large diameter, there may be adequate height for the periscope eyepiece within the pressure hull. When it is impossible to provide adequate height within the pressure hull, a conning tower must be placed on top of the pressure hull. In such case, the periscope can be extended to the point where the eyepiece is at an adequate standing or seated height within the conning tower. In addition, the rudder control station and parts of the fire-control system can be accommodated in this conning tower.

A pressure-resistant conning tower will reduce surface stability and will increase submerged stability. This will have an adverse effect on small, single-hull submarines because they already have less stability during surface cruising than during submerged cruising.

A pressure-resistant access shaft, with the hatch topside and the control room hatch at the bottom, replaces the conning tower when the latter is not required.

The configuration of the free-flooding and free-venting superstructure surrounding the conning tower or the access shaft may vary greatly (Figure 82). It depends primarily on whether a submarine or a submersible is being designed. The design of the superstructure for the submarine depends on the locations selected for the bridge, the retractable equipment, and possibly also on weapon armament. The retractable equipment is decisive for superstructure configuration in the case of the submersible.

The specifications will generally indicate whether a single-screw or a twin-screw propulsion system is required. Individual studies must be made to determine the size and type of the propulsion plant. Corresponding studies are made for the other installations such as the compressed air system, the drain system, the ventilation system, etc. The energy requirement must be determined as precisely as possible at this stage of the design because this factor is essential for determining the cruising range of the boat, particularly at slower speeds.

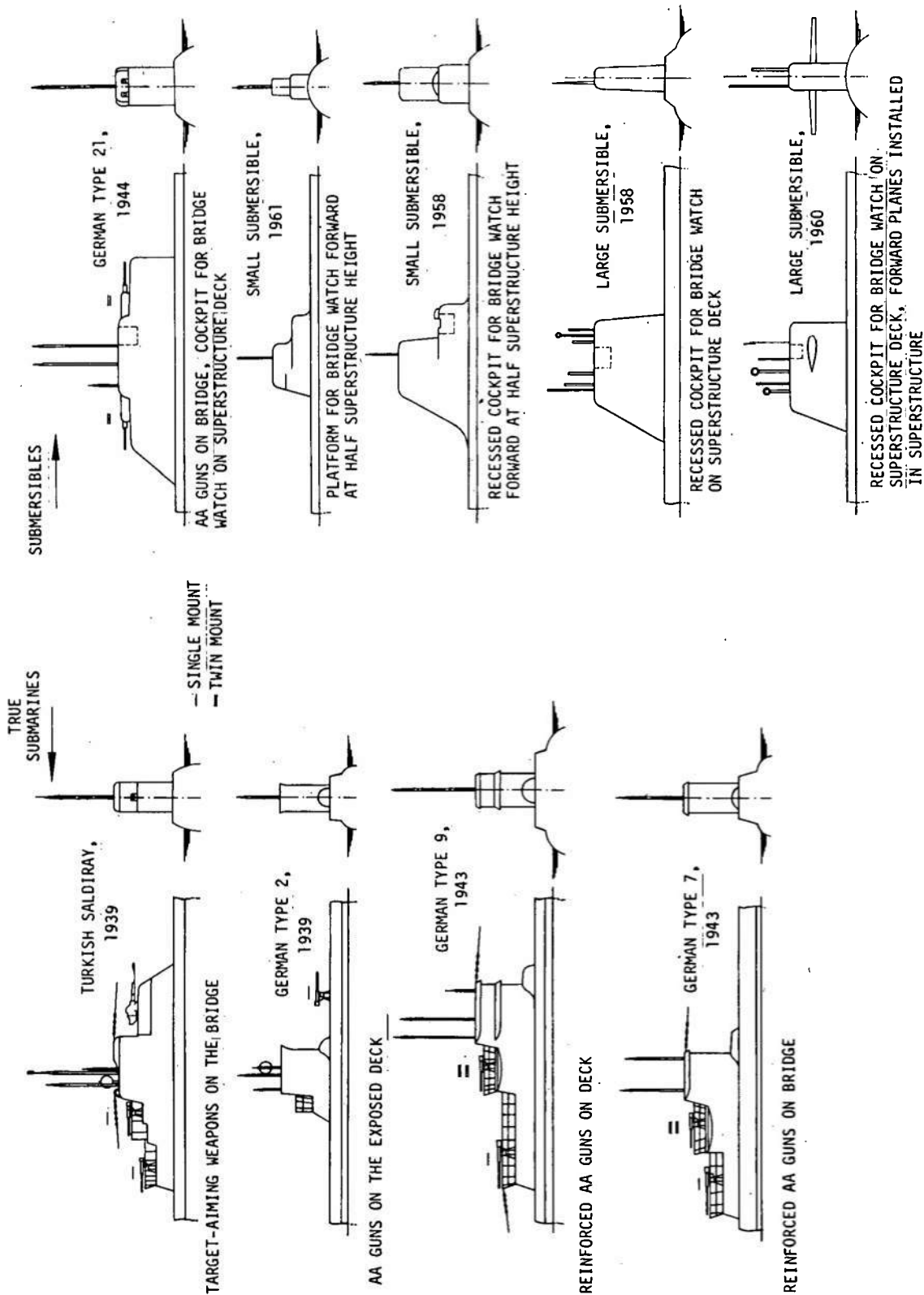

Figure 82 - Superstructures of Submarines and Submersibles

A parallel effort is required in the study of the naval architectural aspects of the steel structure of the pressure and outer hulls.

All of these preliminary studies are made to estimate weight and space requirements. The weight information is used to check flotation. The centers of gravity of weights to be installed must be known quite precisely in order to estimate stability. Locations of these elements in the boat must be specified.

The next step is to develop an overall sketch that includes such important elements as armament, communication and detection equipment, propulsion plant, operating controls, traffic routes, maintenance and repair facilities, crew accommodations, and many other details.

This is followed by a preliminary compilation of all weights. The determination of pressure-resistant displacement is a parallel effort based on the selected pressure hull configuration. The comparison between weight and submerged displacement will yield the ballast required for stability. Now the approximate stability calculations can be computed for surface and submerged cruising.

Then the submarine is drawn in its entirety. This yields the form displacement, and, in turn, provides the first approach for determining the required propulsion ratings for surface and submerged cruising.

The complex interrelationships that exist among the great variety of different effects usually require a number of preliminary designs before a type design can be developed and approved for construction.

Attempts can also be made to determine the principal dimensions of a submarine directly by using a design equation. This procedure equates weight to submerged displacement. Weights are used as direct inputs when they are of constant magnitude, e.g., in the case of the armament, or they are expressed as functions of the diameter of the pressure hull or as coefficients when they are influenced by the size of the submarine. Accordingly, the submerged displacement is expressed in terms of the diameter of the pressure hull and other coefficients. The equation is solved to yield the diameter of the pressure hull. Finally, all the necessary principal dimensions are obtained from the pressure hull diameter and the selected coefficients. The solution is dependent on random factors because of the

many coefficients that must be stipulated. This procedure usually yields unsatisfactory results in the case of submarine construction.

The results of the development of type designs are usually presented in the form of a brief description that includes main data and a sketch of the specific type. The following items are included in the description:

1. The principal dimensions such as overall length, maximum beam, height from keel to deck, height from keel to upper edge of superstructure, periscope depth, draft, pressure hull length, and pressure hull diameter.

2. Displacement data such as surface displacement, submerged displacement, and standard tonnage.

3. Propulsion ratings such as surface speed, submerged speed, surface and submerged cruising ranges at different speeds, and time required to charge batteries.

4. Information on armament, detection systems, size of proposed crew, and endurance in days.

As a rule, a given set of specifications will yield several different designs all of which are feasible. The contractee must then decide which of the designs submitted best meets his specifications and should therefore be approved for the development stage.

DEVELOPMENT OF CONSTRUCTION DETAILS

Construction details are developed from the type of design selected and must be completed before construction can begin. These details include calculations, drawings, and descriptions which are all sufficiently detailed to adequately define the construction and delivery. This construction information can then be used by the contractee to solicit competitive bids from shipyards.

The lines drawing (see Figures 5, 6, and 9) is approximately the same as for other types of ships.

Because the pressure hull plating is relatively thick, it may be advisable to draw the pressure hull lines for the outside of the pressure hull instead of for the molded line (that is, the inside of the plating) otherwise used in shipbuilding.

The graphical presentation of the results of the calculations (the curves of form) is prepared in the same way as for other ships (Figure 83).

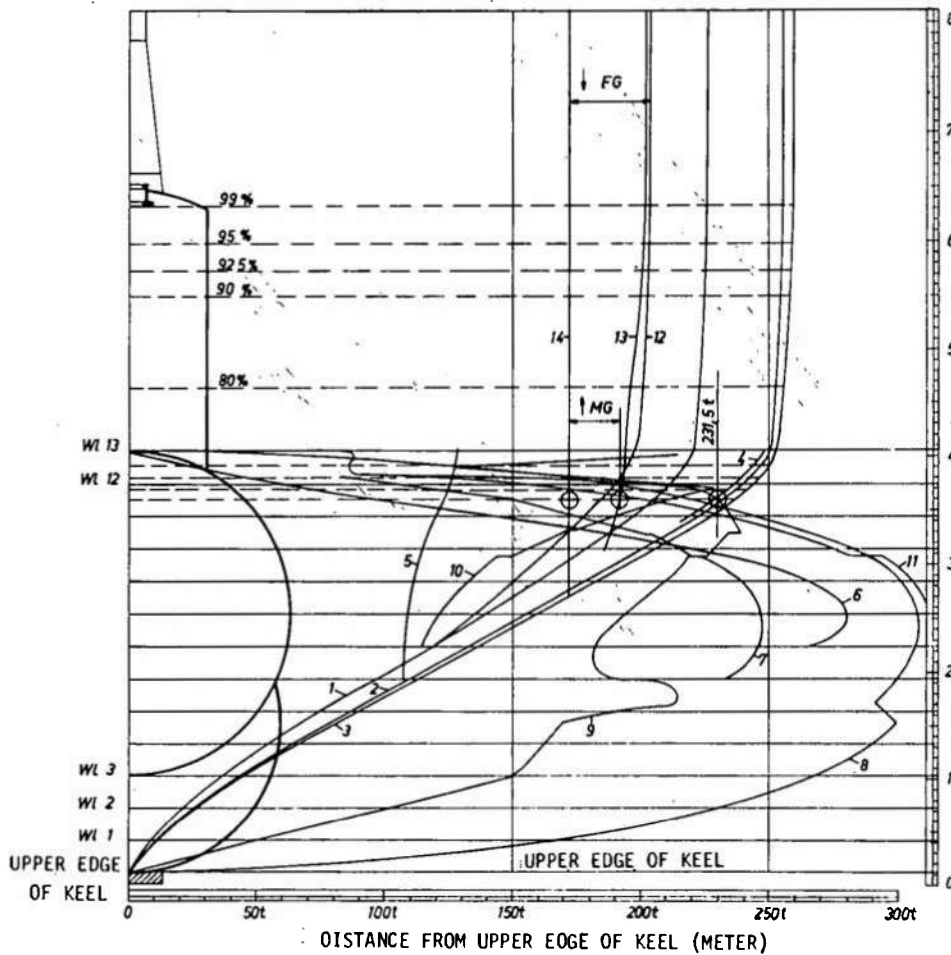



- 1 PRESSURE HULL DISPLACEMENT
- 2 PRESSURE HULL DISPLACEMENT PLUS NET CAPACITY OF BALLAST TANK, INCLUSIVE
- 3 RESIDUAL WATER, WITHOUT FLOODED COMPARTMENTS
- 4 WITHOUT RESIDUAL WATER
- 5 VOLUME CENTERS OF GRAVITY
- 6 TRANSVERSE MOMENT OF INERTIA OF THE WATERPLANE AREAS
- 7 LONGITUDINAL MOMENT OF INERTIA OF THE WATERPLANE AREAS
- 8 WATERPLANE AREAS WITHOUT FLOODED COMPARTMENTS
- 9 WATERPLANE MOMENTS
- 10 WATERPLANE CENTERS OF GRAVITY FORWARD OF AFTER PERPENDICULAR
- 11 UNIT TRIMMING MOMENT
- 12 VOLUME CENTERS OF GRAVITY FOR HEIGHT EQUATED TO UPPER EDGE OF KEEL
- 13 TRANSVERSE METACENTER
- 14 WEIGHT CENTER OF GRAVITY ABOVE UPPER EDGE OF KEEL, WITHOUT RESIDUAL WATER

Figure 83 - Displacement and Other Curves of Form

In addition, the ballast tank volume is plotted above the pressure hull displacement curve to yield, among other information, the surface and the submerged displacement. The residual buoyancy during diving can be measured from the increase in pressure hull displacement above the line of flotation.

The exact location of the line of flotation and the trimmed position on the surface cannot be determined from the curves of form. The sectional area curves for surface displacement are used to obtain this information. The location of the line of flotation is determined by iteration from the sectional area curves with sufficient accuracy for the given magnitude of surface displacement. Initially, several (three to four) lines of flotation are assumed, and their associated displacements and centers of gravity are determined with the aid of the sectional area curves. The fairing of these lines will then yield the actual line of flotation whose displacement corresponds to the weight of the submarine and whose center of buoyancy is located in the same plane as is the center of gravity.

The longitudinal sectional area curve (called a "flounder") is important in determining the submerged longitudinal center of buoyancy (Figure 84). The latter must be located vertically above the longitudinal center of gravity during submerged cruising. The "flounder" will also establish whether or not the intended ballast tank volume is available and whether it is properly distributed. Moreover, it can be used to verify the size and location of the fuel tanks, trim tanks, etc. The area below the lines marked  on Figure 84 presents the surface displacement. Those marked  indicate the submerged displacement (including ballast tank capacities), and the area below the outer envelop line shows the form displacement.

Vertical volume curves are plotted for all tanks and cells; strength calculations for the pressure hull and for the other members are made at the same time.

The dimensions of the construction members are then determined. The steel scantling plan and the midship section (Figure 85) are framed. These give important material thicknesses and material distribution. Strength tests on models may be required to substantiate the results of the calculations or to prove the strength of those parts which are not amenable to precise calculation.

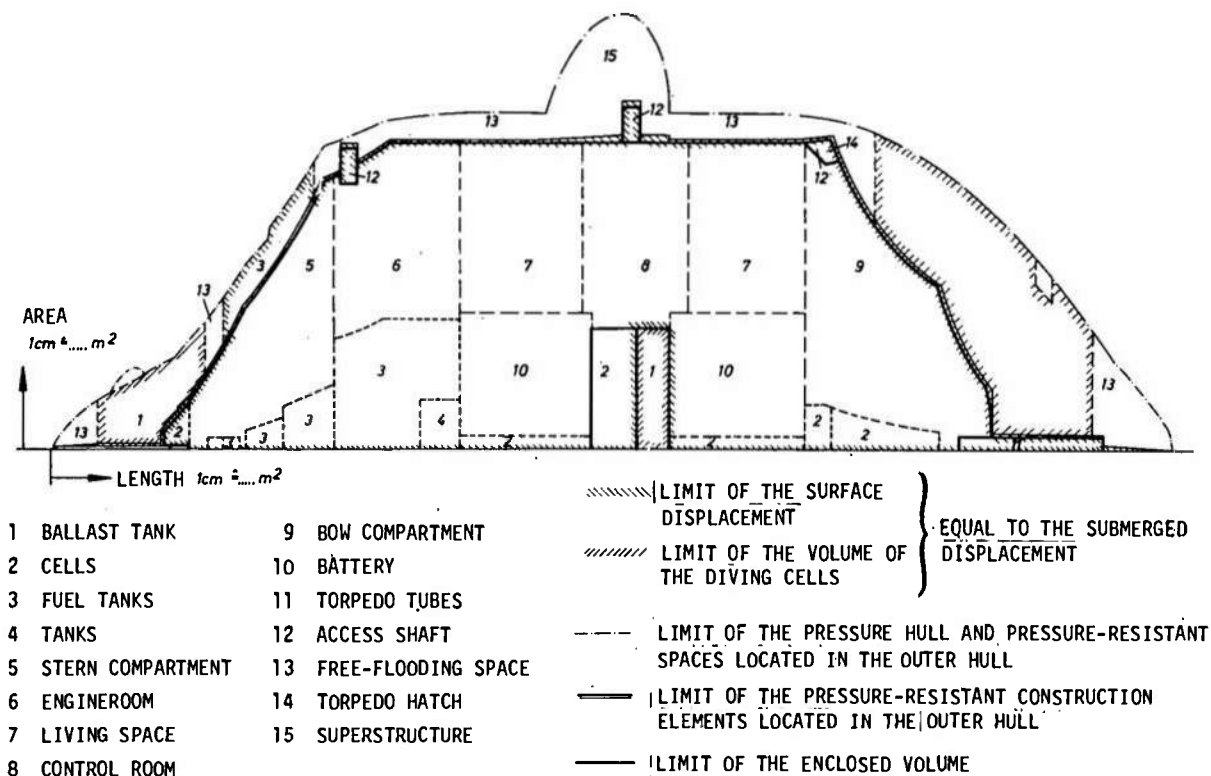

Figure 84 - Longitudinal Presentation of Sectional Area
(See Figure 1 for designations of cells, fuel tanks, etc.)

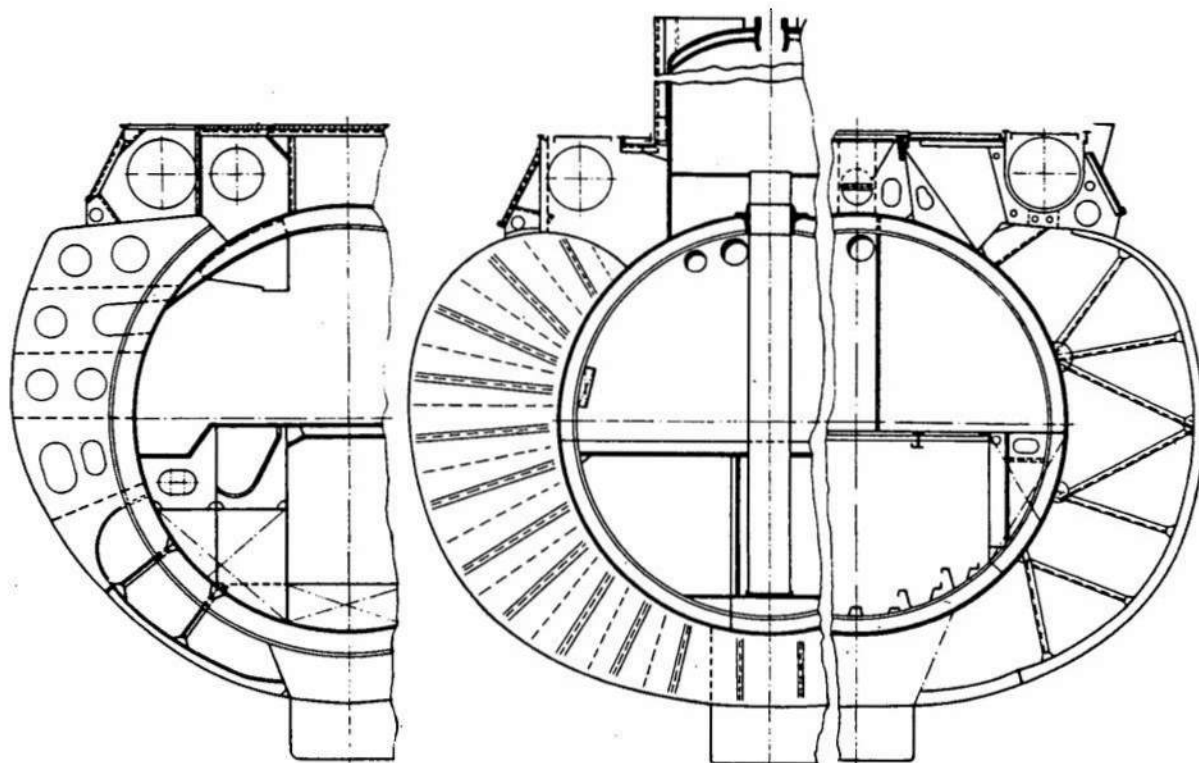

Figure 85 - Midship Framing

After the lines have been determined, towing and other tests are carried out in a model basin.

Detailed planning for the propulsion plant starts when the required submerged and surfaced engine ratings have been established along with the associated propeller rpm.

Technical data (such as output, efficiency, and possibly fuel consumption) as well as precise weight and space requirements for the individual components are coordinated with the manufacturers of diesel engines, electrical motors, network systems, batteries, etc. Calculations are made for vibration, engine shock mounts, noise reduction and absorption, and cruising ranges. Accurate propulsion plant installation plans are then drawn to a larger scale, allowing for the architectural aspects. Similar installation drawings are prepared for the auxiliaries, the ship service facilities, the armament, the detection devices, and all other parts. Detailed calculations have to be made and dimension specifications written for the electric network, the drain system, the compressed air, the pressure oil circulation, the ventilation systems, and all other independent plants.

Wooden mockups of the most important compartments (scale of 1 to 1) are frequently built. These are important aids for arriving at well-planned designs and for providing accurate drawings. Because of the cramped spaces aboard ship, it is important to use models to examine the possibilities for optimum space utilization. This is particularly true when bedding complicated piping lines. Moreover, mockups are useful to investigate the maintenance aspects of instruments.

Weight and volume calculations complete the basic construction details. Here the individual weights and centers of gravity of all structural elements are determined for both the vertical and longitudinal directions. The weights for the major units, e.g., hull, propulsion plant, etc., together with their associated centers of gravity, are calculated in accordance with conventional practice (systems differ from one navy to another). This is followed by an accurate calculation of the center of gravity of the weight for the submarine as a whole; it is made initially without including the stability ballast. The pressure-resistant submerged displacement is similarly determined with respect to size and to vertical and longitudinal centers of gravity. The difference between total weight

and pressure-resistant submerged displacement is compensated for by ballast. The ballast is arranged longitudinally so that the overall center of gravity of the boat and ballast is located vertically below the longitudinal center of buoyancy of the submerged displacement. The overall design will be acceptable only when this calculation proves that the ballast center of gravity will be located approximately midships.

Were the ballast center of gravity located near one end of the hull, even a small excess of weight at the other end of the boat would be enough to shift the ballast center of gravity too much. It might then be no longer possible to stow the ballast within the boat, and it would obviously not be feasible to build such a submarine.

The stability ballast is stowed as low in the submarine as possible. The difference between the height of the center of buoyancy F and the height of the center of gravity G , including ballast, is called the submerged stability (allowing for free surfaces in the submarine) (see Figure 4).

The curves of form including the metacentric height above the keel, as in the case of other types of ships. The difference between this measure and the height of the center of gravity for the submarine plus ballast is called the metacentric height during surface cruising (allowing for free surfaces). A small amount of necessary stability ballast is an indication of a favorable overall design.

In addition to the stability ballast already mentioned, trim ballast is stowed forward and aft in the pressure hull. It can be used to correct minor weight shifts in service that were not foreseeable at the time of design. Trim ballast is also a part of the weight calculation.

Some of the detailed drawings required for ship construction are frequently not available at the time the weight and volume calculations are completed for the construction layouts. Moreover, in most instances, not all the weight information will have been supplied by the subcontractors and so not all the weight data can be considered final at this point. Therefore, the first weight and volume calculations that are submitted include *estimated weights*. For this reason, a construction allowance is introduced for individual weight groups. It is assumed that the centers of gravity for the different construction allowances are located in the

center of gravity of the construction group in question. The overall allowance required depends on the status of the design effort. When the design is completed, the allowance can be absorbed if all weights have been calculated from detailed drawings or have been provided by the subcontractors.

The shipyard must be provided with a building allowance. As in the case of the construction allowance, this is distributed among the major groups and will cover any excess weight which may develop during the building period. The pressure hull has to be heavier than calculated on the basis of nominal plate thickness because only plates with excess tolerance are allowed to be used. Moreover, the subcontractors must be allowed a certain admissible excess weight, e.g., because of the tolerances of the castings. This building allowance may be absorbed when the submarine is delivered. If the boat is even heavier, the contract specifications may no longer be met.

A certain maintenance allowance is provided to cover service contingencies which may have to be negotiated separately by the contractee. The maintenance allowance is intended to compensate for excess weights that may be caused by additional equipment during the service life of the submarine. This maintenance allowance must be available in the form of ballast when the submarine is commissioned. The trim ballast mentioned above can be part of this allowance if this was agreed to in the contract. The maintenance allowance is part of the weight calculation.

The results of this effort are documented in the form of a detailed description (*building instructions*). This is supplemented by such drawings as the overall plan (general plan) and all the other drawings and calculations that may be necessary to present all aspects of the submarine.

CHAPTER XVI

CONSTRUCTION AND COMMISSIONING

Certain special features distinguish the construction of submarines from that of other combatant ships.

Weight control on submarines must be exercised with much greater care than in the construction of other ship types to ensure that the weight specified in the weight and volume calculation will remain within specified limits upon completion. If it is exceeded by more than the permissible allowance, the stability ballast may have to be reduced to the point where the guaranteed stability can no longer be provided. If it is below the specified weight, there may be no stowage space for additional ballast. Components supplied by subcontractors and parts manufactured by the shipyard must be weighed in the shipyard. Weight records are to verify the weight calculation from time to time during construction.

The *pressure hull is strength tested* with special care throughout the construction phase. The materials are subjected to technological testing and inspected for nominal thickness. Plate thickness tolerances below specifications that are otherwise authorized in ship construction cannot be tolerated for the pressure hull. The welded seams of the pressure hull are X-rayed for quality and are inspected by other procedures as well. Fuel tanks, cells, and tanks are pressure tested in accordance with the pressure data table of the building instructions. Particular care is taken to inspect the pressure hull for any excessive deviations from the circular form.

Unlike other ships, a submarine must be almost completely finished on the slipways. The internal construction must be almost completed because the hatches must be closed during launching. The batteries must be installed for stability reasons, the low-level fuel tanks must be filled with water, and the ballast must be stowed.

A variety of construction techniques are used during the building period. The most economical building procedure in the case of an individual submarine is to assemble the hull from individual elements on the ways. In this case the pressure hull plating will extend in the longitudinal direction

(Figure 86). The lower shell of the pressure hull is placed in a scaffold and the circular frames are installed. Each frame is kept circular by iron ties. Next the upper shell is covered with plating. Only machinery that will not pass through the assembly hatch is installed before the pressure hull is closed. Installation of the propulsion plant, pipelines, electrical system, armament, and other internal components begins when the steel structure of the hull is completed.

This technique was adopted when riveting was the rule. From the standpoint of welding technology, it has the basic disadvantage that many seams cannot be welded in a favorable position. The use of automatic welding machines is limited because the pressure hull cannot be rotated about its longitudinal axis.

The pressure hull can also be built of individual sections fabricated in a shop (Figure 87). Here the pressure hull plating is installed transversely. The sections are rotated into the most favorable position for welding by using a special jig, thus permitting the unlimited employment of automated welding machines. Sections are moved to the slipways and welded together there. Moreover, the outer hull and superstructure can be prefabricated in sections and assembled on the slipways.

The remainder of the assembly operations takes place as described above. A prerequisite for this *sectionalized construction* is availability of adequate transportation equipment and lifting gear.

If the program includes a large series of submarines, it may be worthwhile to install in the sections the maximum number of propulsion plant components, pipelines, electrical system, armament, and other internal members before the sections are even moved to the slipways (prefabricated assembly). In this type of construction, called *fully sectionalized construction*, the greater accessibility allows more assembly personnel to be employed simultaneously than in a pressure hull that is already sealed. The prerequisite is that the sectionalized subdivision must be taken into consideration during the design phase. For instance adapters must be provided between fore-and-aft pipelines where the sections join. The area between the frames near the section joints must be kept free of installations to ensure that the sections can be welded together properly when they are on the ways.

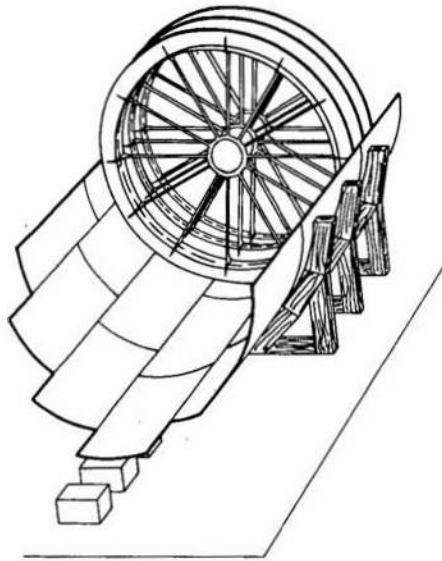

Figure 86 - Assembly of a Pressure Hull
on the Slipways

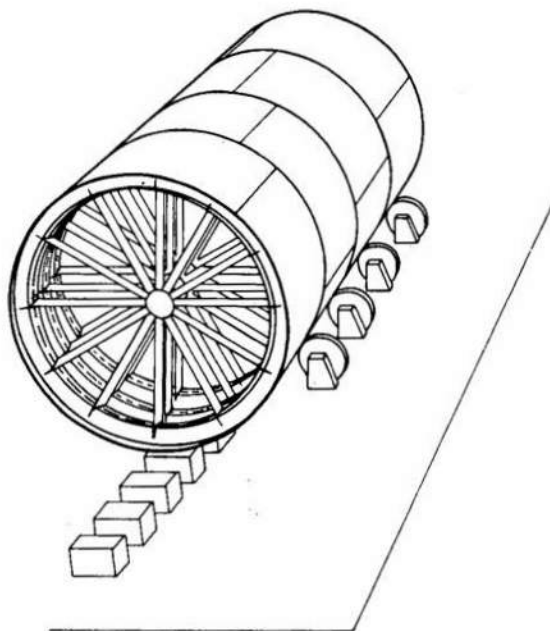

Figure 87 - Assembly of a Pressure Hull by Sections

After the pressure hull has been built, final assembly follows. The time required for this purpose will depend on the extent to which the sections have been prefabricated. The advantages in this type of construction are that the submarines can be delivered in a rapid sequence and that the ways can be utilized to maximum capacity. The completely prefabricated sections require heavy transportation equipment and lifting gear to move them to the slipways.

Construction costs are reduced only when the saving in labor costs is greater than the additional expense of heavy-lifting gear and transportation equipment.

Launching is followed by individual trials of all systems, e.g., the high-voltage test of the electrical network during which insulation quality is verified, dock trials of the propulsion plant, and so forth. The submarine is given its final coat of paint, inside and out.

All valves and closures that must be in the "closed" position for diving are marked accordingly (with red paint). Diving tables are installed in the individual compartments to indicate the closure status of all fittings that must be established before diving.

The first diving test is in the form of a trim test with the boat at rest. It is preceded by a test of the ballast blow systems as well as by a negative pressure test. Safety requires that the first diving test be performed under a pierside crane whose hook is attached to the submarine by heavy cables. The crane hook is slackened but ready for hoisting during the dive. The first diving test can also be made in a flooded dry-dock. Trim is level during this submerged trim test. Water levels in the trim tanks and in all other tanks and cells are measured with the submarine in "square" position. Sea water density is measured. The condition of the equipment and the distribution of the crew are determined and recorded in tabular form. The location of the surface line of flotation is determined and compared with the calculated line after the boat has surfaced and the tanks have been completely emptied. The weight condition of the boat during the trim test is converted to the status of the fully equipped boat corresponding to the weight and volume calculation. The following are examples of the deviations that can result:

1. The submarine is lighter or heavier than designed.
2. The submerged displacement is less or greater than designed.
3. The weight calculations contain errors.
4. The volume calculations contained errors.

Such deviations are compensated for by shifting ballast. A trim control test is made after the ballast has been shifted. This is followed by heeling tests in the submerged and surfaced conditions.

The performance of a new type of submarine with relatively small ballast tank volume must be evaluated with great care when the submarine is cruising ahead and astern in order to draw conclusions as to whether there is any possibility of a dangerous "under cutting" at higher surface speeds.

Submarines become more and more bow heavy with increasing surface speed. This effect is reduced by using a small "up" angle at the aft or forward planes. Special trials are required to determine the optimum diving plane attitude for surface cruising.

Measured mile runs are conducted to verify the results of towing tank tests, the performance of the propulsion plant, and the range of surface speeds available. This is followed by turning circle trials, anchor tests, and other surface cruising tests.

The submarine is usually commissioned at this point. Submerged trials are run with the assistance of the crew. The following individual trials are required: depth control and turning circle trials, snorkel trials, submerged mile runs, buoyancy and trim measurements at different diving plane angles, buoyancy measurements at different trim angles of the boat as a function of submerged speeds, verification of cruising ranges, listening tests, crash dive tests, firing trials, and tests of detection and communication equipment.

The final acceptance takes place when trials and tests have proven that the shipyard has met its contractual obligations.

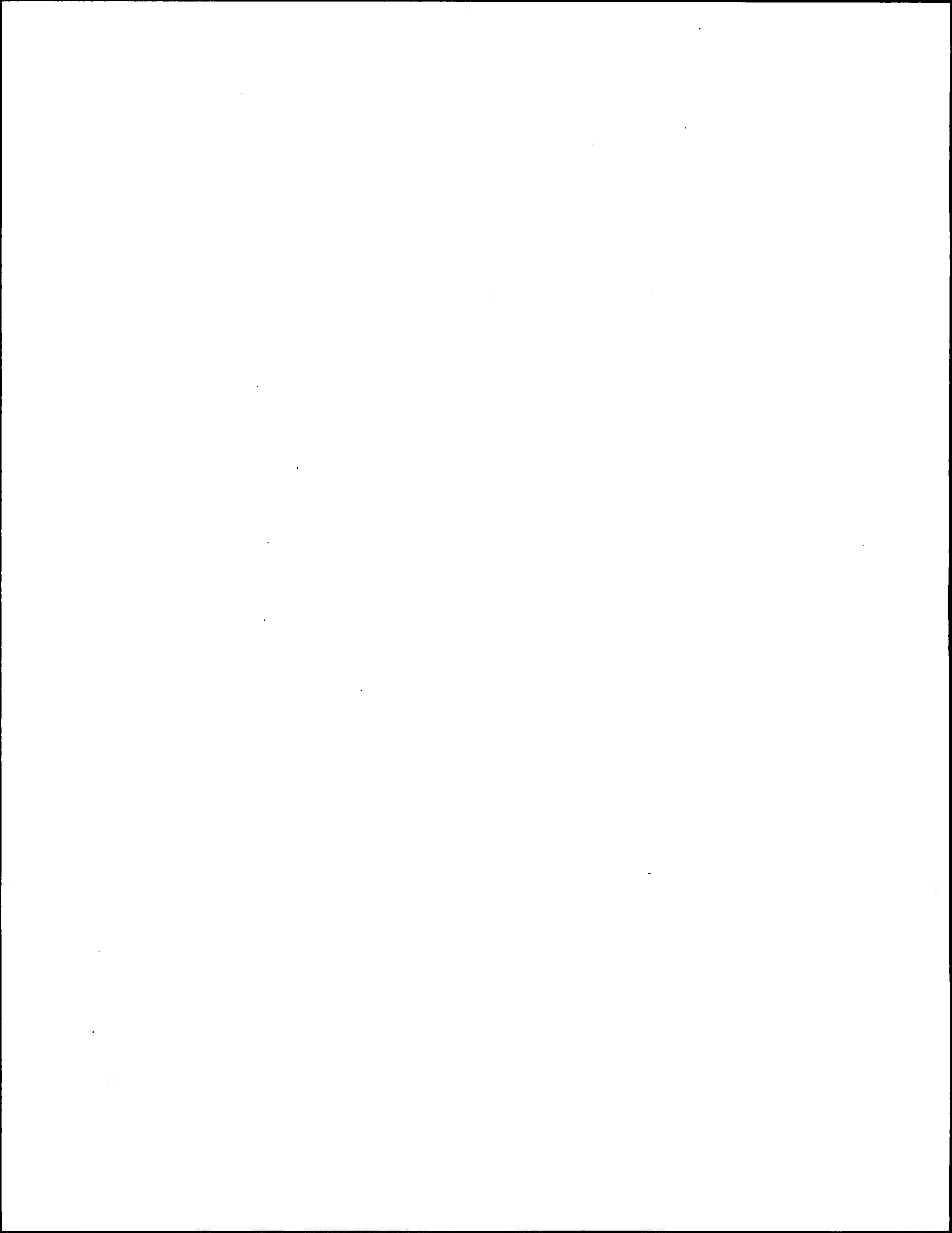

APPENDIX

GERMAN SUBMARINES AND SUBMERSIBLES

TABLE 2 - SUBMARINES, 1935-1939

TYPE 2b, 1935

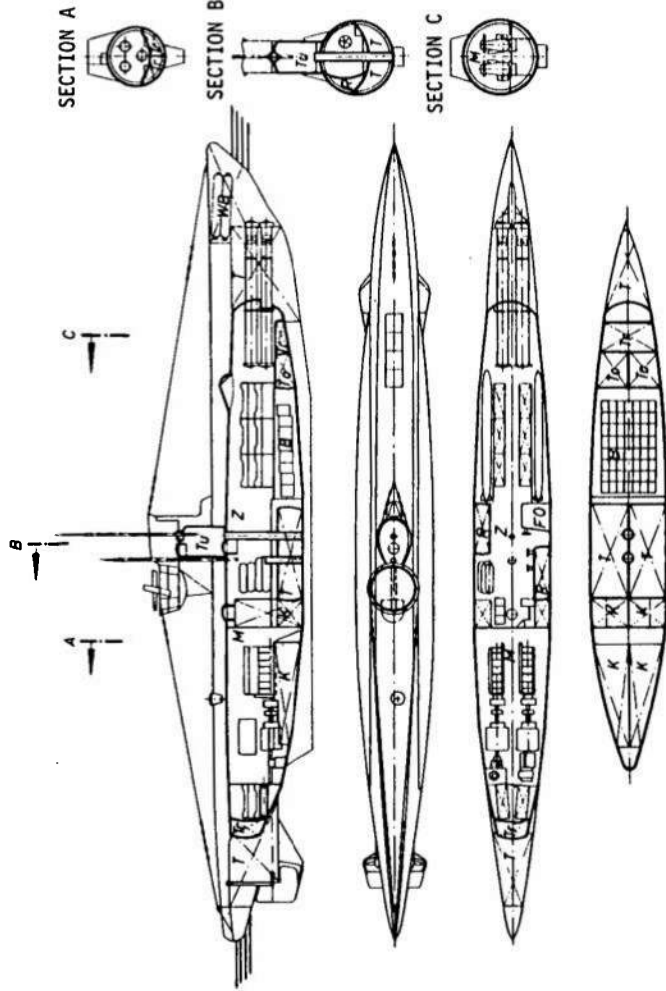

LEGEND

- T BALLAST TANK
- K FUEL TANK
- TB BALLAST/FUEL TANK
- R REGULATING CELL
- RB REGULATING FUEL OIL TANK
- U NEGATIVE BUOYANCY TANK
- Tr TRIM TANK
- To TORPEDO TANK
- MB WATERTIGHT BOW
- MH WATERTIGHT STERN
- Z CONTROL ROOM
- B BATTERY COMPARTMENT WITH BATTERY
- M ENGINE ROOM
- F COMMUNICATION ROOM
- O SONAR ROOM
- Tu CONNING TOWER
- Ot UPPER DECK TUBE FOR RESERVE TORPEDOES
- Sch SNORKEL

TABLE 2 CONTINUED

TYPE 9b, 1939

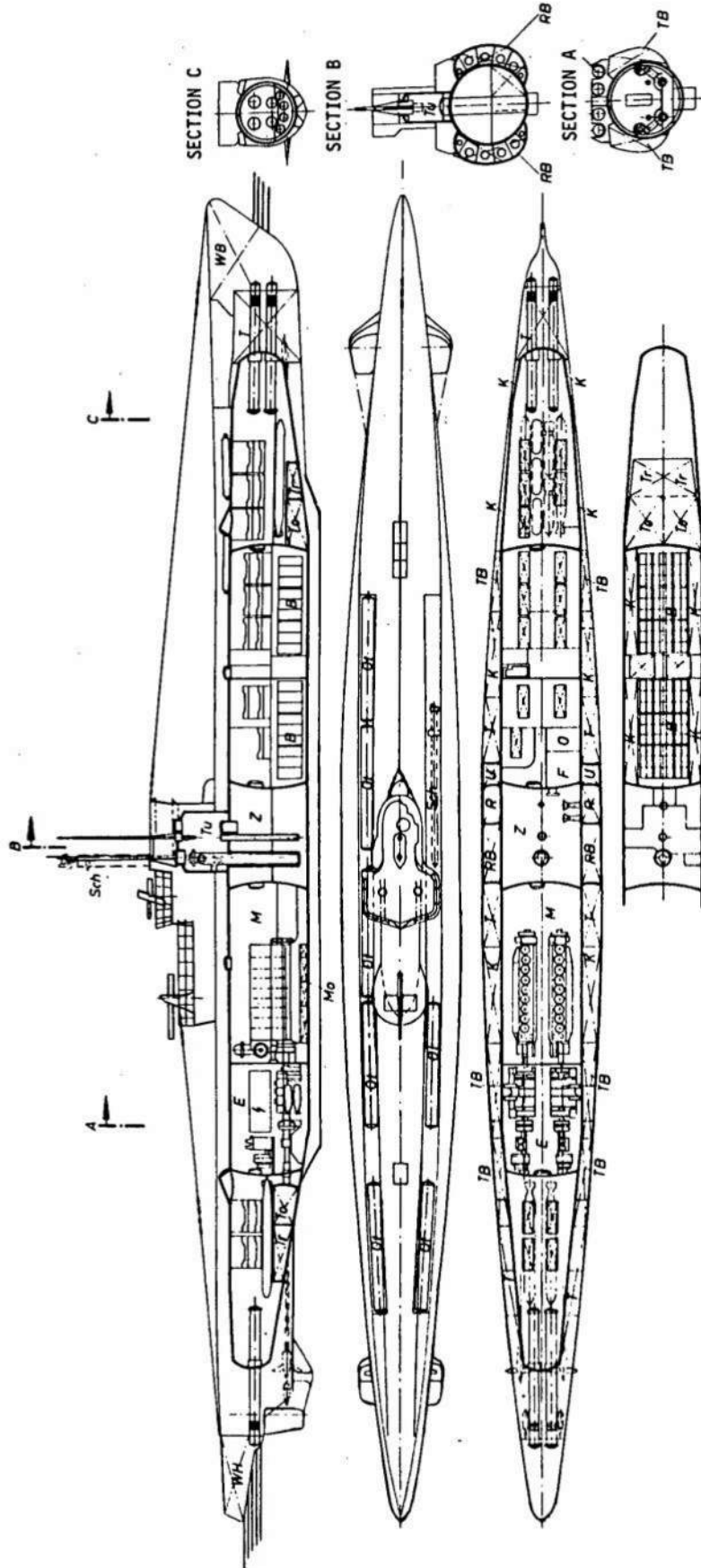

TABLE 2 CONTINUED

TYPE 7c, 1939

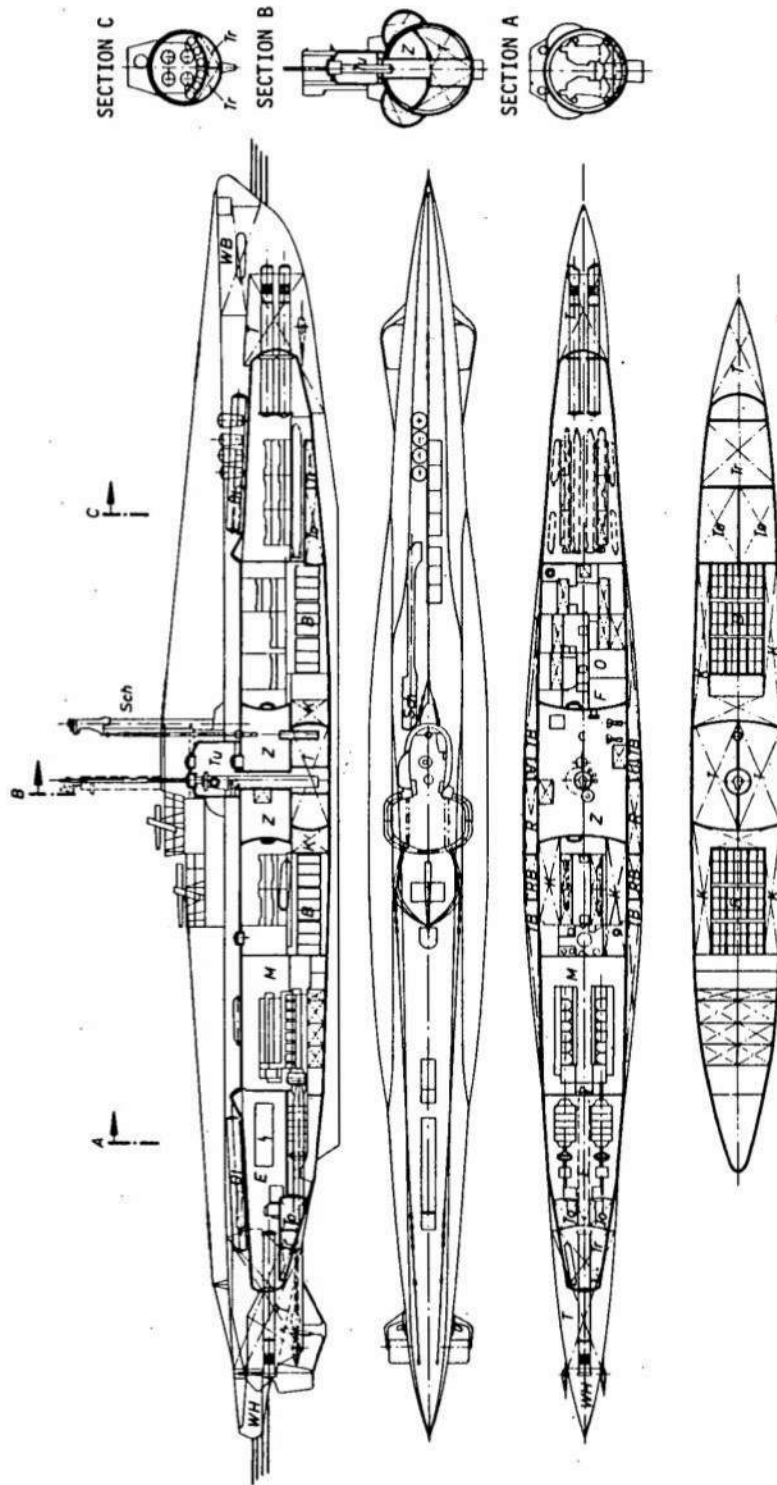

TABLE 3 - SUBMERSIBLES, 1944

TYPE 23, 1944

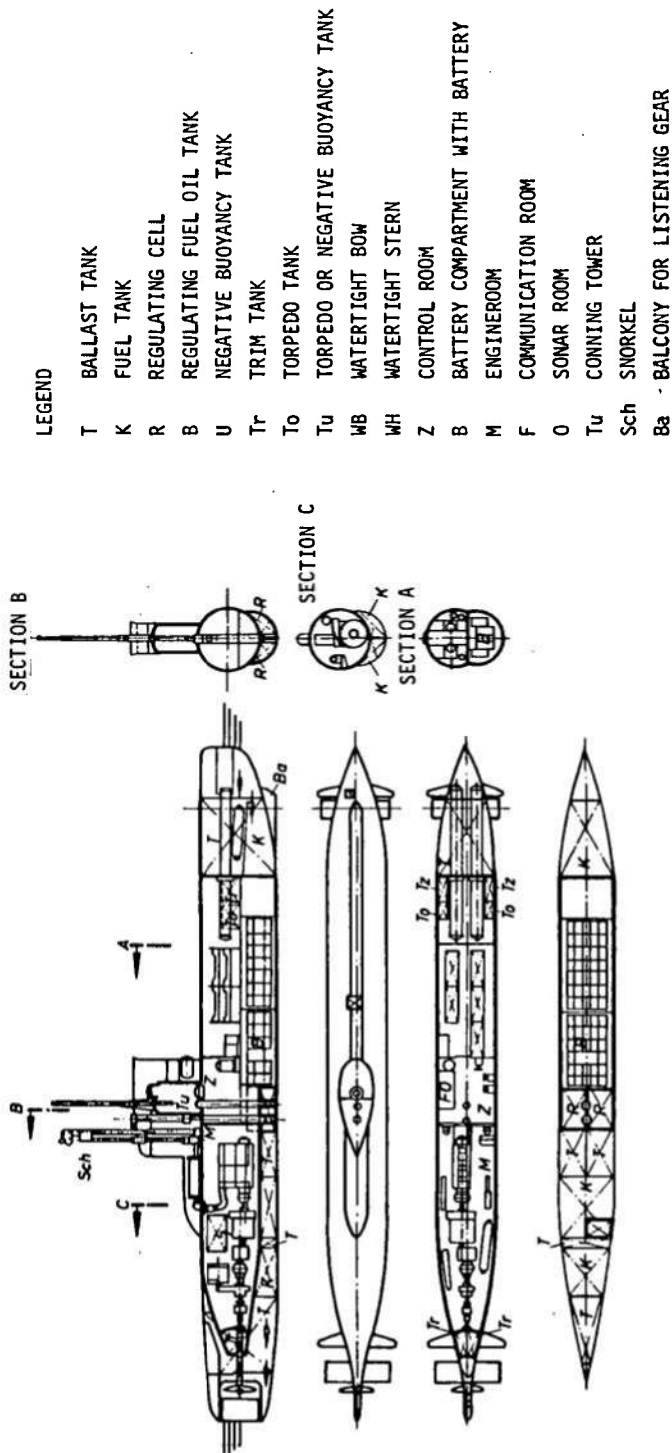

TABLE 3 CONTINUED

TYPE 21, 1944

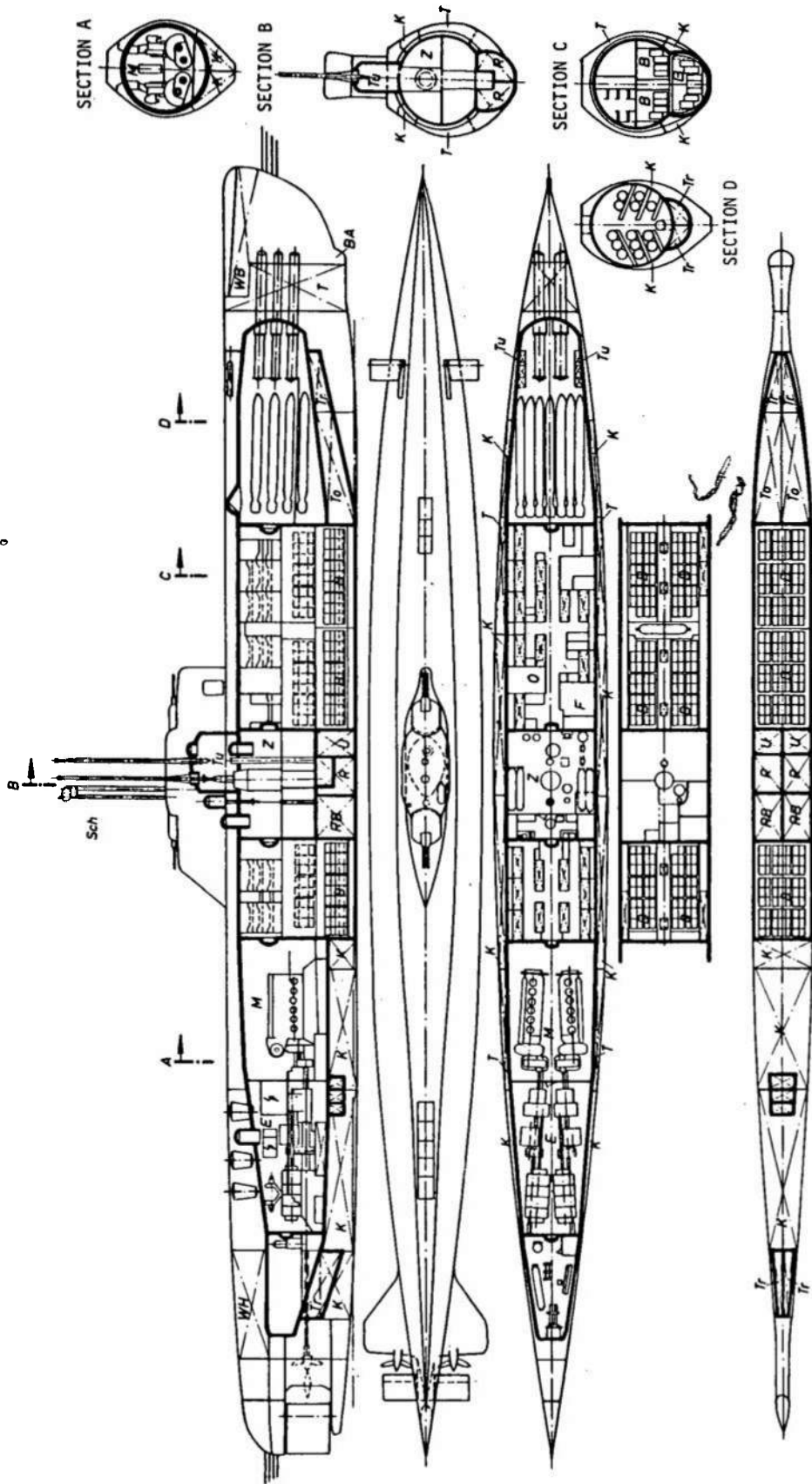

TABLE 4 - SUBMERSIBLE WITH WALTER PROPULSION SYSTEMS, 1939-1945

TYPE V-80, 1939

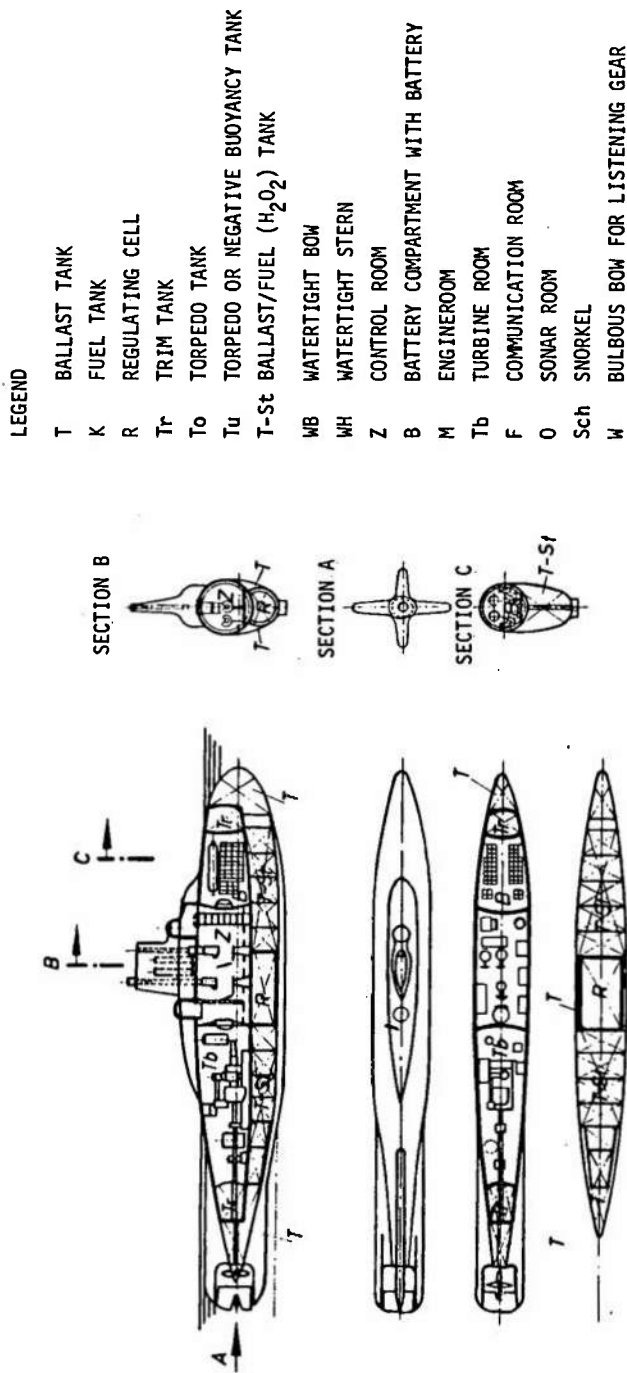

TABLE 4 CONTINUED

TYPE 17b, 1944

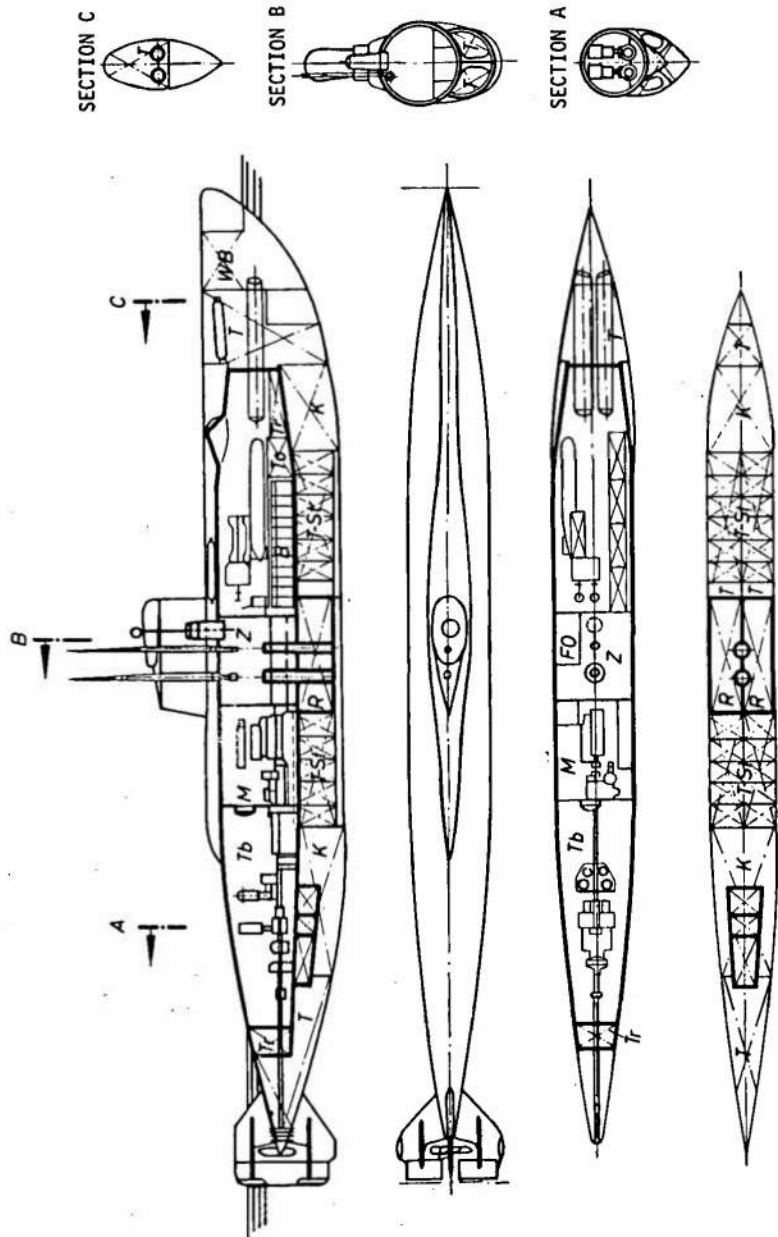
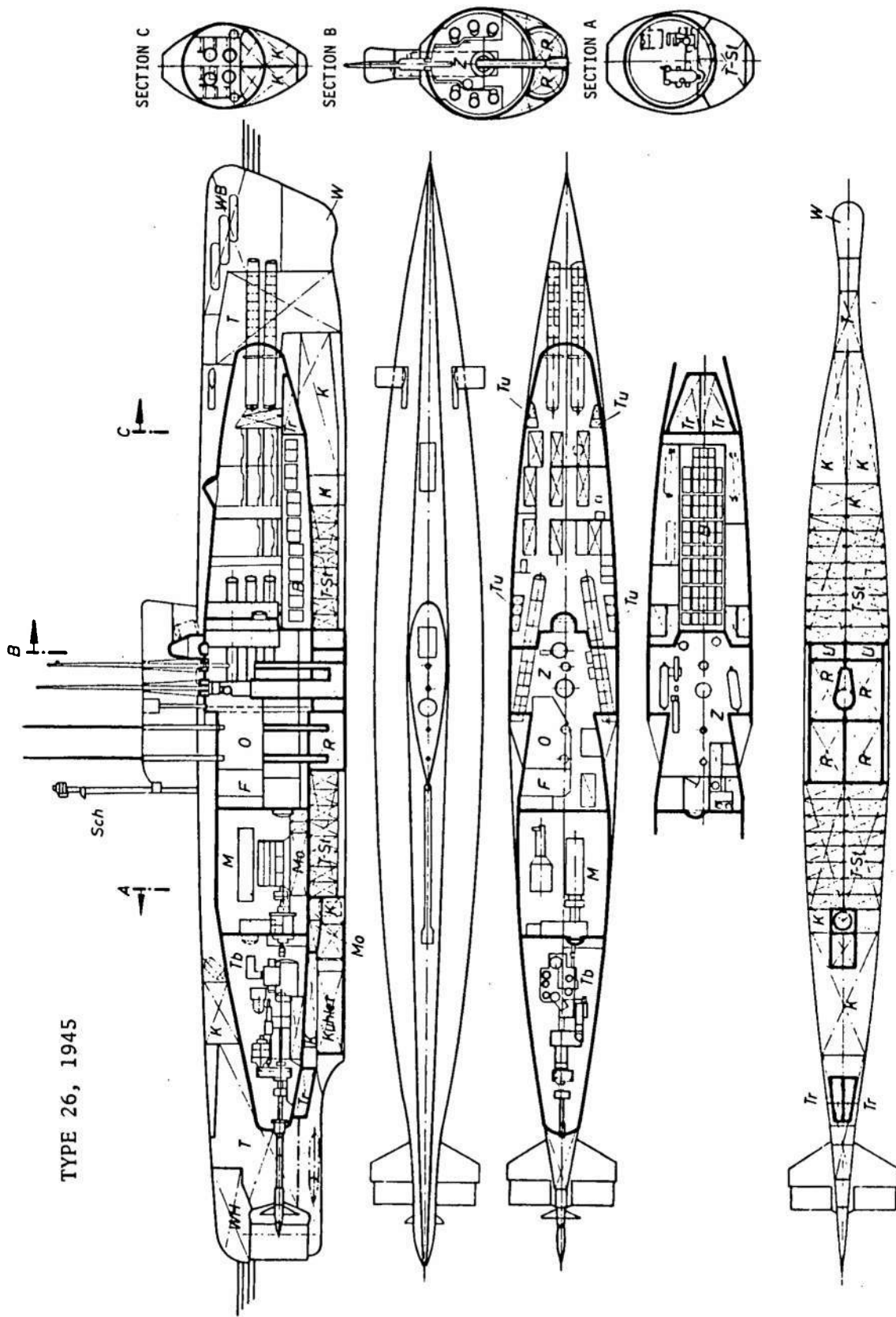

TABLE 4 CONTINUED

TYPE 26, 1945



BIBLIOGRAPHY

BOOKS

Techel, H., "Der Bau von Unterseebooten auf der Germaniawerft (Submarine Construction in the Germaniawerft Shipyard), (1922).

Johow-Förster, "Hilfsburch für den Schiffsbau" (Shipbuilding Manual), Section 8 (1928).

Evers, H., "Kriegsschiffbau" (Warship Construction), Appendix (1943).

Newton, R. N., "Practical Construction of Warships" (Chapter on Submarines), (1944).

"Weyers Flottentaschenbuch" (Weyer's Fleet Yearbook), different years.

ARTICLES

Fischer, K., "Neuzeitlicher U-Boots-Bau" (Modern Submarine Construction), Nauticus (1952).

Schade, H. A., German Wartime Technical Development, Trans. SNAME (1946).

McKee, A. J., "Recent Submarine Design Practices and Problems," Trans. SNAME (1959).

Arentzen, E. S. and P. Mandel, "Naval Architectural Aspects of Submarine Design," Trans. SNAME (1960).

Kurzack, K. H., "Neuzeitliche Kriegsschiffsantriebe" (Modern Warship Propulsion Systems), Nauticus (1956).

Kruska, E., "Das Walter-Verfahren, ein Verfahren zur Gewinnung von Antriebsenergie" (The Walter Technique, a Process to Acquire Propulsion Energy), Zeitschrift VDI (1955).

Snay, H., "Unterwasser-Explosionen hydromechanische Vorgänge und Wirkungen" (Underwater Explosions, Hydromechanical Processes and Effects), Jahrbuch d. S.T.G. (1957).

Giessler, H., "Unterwasser Ortung" (Underwater Detection), Nauticus (1956).

Maass, H., "Anforderungen der Unterwasserschalltechnik an den Kriegs-und Handelsschiffbau" (Requirements Imposed on Combatant and Merchant Ship Construction by Underwater Sound Ranging Technology), Jahrbuch d. S.T.G. (1961).

Brökelmann, J., "Aufgaben und Entwicklung der U-Bootsabwehr" (Tasks and Development of Antisubmarine Warfare), Nauticus (1958).

INITIAL DISTRIBUTION

Copies		Copies	
1	CNO (Op-098T8) (Capt. B. Petrie)	60	NAVSEC
2	CHONR 1 Mr. N. Basdekas, Code 439 1 Dr. N. Peronne		1 SEC 6100B, Capt. C.E. Martin
1	NRL, Mr. W. Pellenni, Code 6300		1 SEC 6100B, Capt. J.E. Rasmussen
3	NAVMAT 1 MAT 03L, Dr. J. Lawson 1 MAT 033B, Mr. O. Remson 1 MAT 0334, Mr. R. Vittucci		50 SEC 6105, Capt. J.L. McVoy
1	USNA, Attn: Lib		1 SEC 6105B, Mr. K. Lovell
1	PGSCHOL		1 SEC 6105G, Mr. J.R. Sullivan
1	USNROTC		1 SEC 6110.01, Mr. R. Leopold
1	War College		1 SEC 6110D, Mr. P. Palermo
1	Submarine Force, Atlantic		1 SEC 6113C, Mr. J.R. Dapper
1	Submarine Force, Pacific		1 SEC 6128, Mr. J.B. O'Brien
8	NAVSHIPS 1 SHIPS 03, Capt. E.C. Svendsen 1 SHIPS 03Z, Capt. C.E. Donaldson III 1 SHIPS 031, Dr. J.H. Huth 1 SHIPS 0342, Mr. G. Sorkin 1 SHIPS 03423, Mr. C.H. Pohler 1 SHIPS PMS 393, Capt. C.E. Slonim 1 SHIPS PMS 396, Capt. H.A. Hoffman 1 SHIPS 425		1 SEC 6129, Mr. R.F. Swann
			1 SEC 6129C, Mr. A. Malakhoff
		1	ARPA
		1	Lib of Congress
		1	MARAD
		1	Nat'l Sci Foundation
		1	Catholic Univ
		1	MIT
1	Submarine Base, New London	1	General Dynamics/ Electric Boat
1	Submarine School, Box 700 Groton, Conn. 06340	1	Ingalls Shipbldg
1	Charleston Naval Shipyd	1	Newport News Shipbldg
1	Hunter's Point Naval Shipyd		
1	Philadelphia Naval Shipyd		
1	Portsmouth Naval Shipyd		
1	Puget Sound Naval Shipyd		

CENTER DISTRIBUTION

Copies	Code
1	00
1	01
1	11
1	15
1	16
1	17
1	1702
1	172
1	173
1	174
1	174.1
1	177
50	1706
1	27

UNCLASSIFIED

Security Classification

DOCUMENT CONTROL DATA - R & D

(Security classification of title, body of abstract and indexing annotation must be entered when the overall report is classified)

1. ORIGINATING ACTIVITY (Corporate author) Naval Ship Research and Development Center Bethesda, Maryland 20034	2a. REPORT SECURITY CLASSIFICATION UNCLASSIFIED 2b. GROUP
--	---

3. REPORT TITLE SUBMARINE CONSTRUCTION

4. DESCRIPTIVE NOTES (Type of report and inclusive dates) Translation from German published by "Wehr und Wissen" Publishing House, Darmstadt, West Germany, January 1964
--

5. AUTHOR(S) (First name, middle initial, last name) Prof. Ulrich Gabler, M.E.

6. REPORT DATE August 1972	7a. TOTAL NO. OF PAGES 180	7b. NO. OF REFS
-------------------------------	-------------------------------	-----------------

8a. CONTRACT OR GRANT NO. b. PROJECT NO. c. d.	9a. ORIGINATOR'S REPORT NUMBER(S) Translation T-349 9b. OTHER REPORT NO(S) (Any other numbers that may be assigned this report)
---	---

10. DISTRIBUTION STATEMENT APPROVED FOR PUBLIC RELEASE: DISTRIBUTION UNLIMITED

11. SUPPLEMENTARY NOTES	12. SPONSORING MILITARY ACTIVITY Naval Ship Research and Development Center Bethesda, Maryland 20034
-------------------------	--

13. ABSTRACT The principles of submarine construction are discussed, in which its status of technology in Germany prior to and during World War II is referred to in many cases. Its purpose is to serve the design and construction engineer and shipbuilder as a handbook and to introduce naval officers and engineers in training to the field of submarine engineering.

14.

KEY WORDS

LINK A

LINK B

LINK C

ROLE

WT

ROLE

WT

ROLE

WT



DUDLEY KNOX LIBRARY - RESEARCH REPORTS



5 6853 01002238 7

U1485

