

UNCLASSIFIED

DEPARTMENT OF DEFENCE

AR-001-185

DEFENCE SCIENCE AND TECHNOLOGY ORGANISATION

ELECTRONICS RESEARCH LABORATORY

TECHNICAL REPORT

ERL-0008-TR

24 V d.c. LOW VOLTAGE COMPENSATOR

B.W. Rice

S U M M A R Y

This report describes the operation and performance of a "24 V d.c. Low Voltage Compensator". This is a device which was built to overcome the problem of low input voltages to electronic equipment when operating them from poorly regulated supplies. It is very useful in trial situations when operating with long lead lengths. It operates by taking some of the input energy and converting it by way of ultrasonic frequencies to a d.c. voltage which is then added in series with the input in order to obtain a constant output voltage.

Approved for Public Release.

POSTAL ADDRESS: Chief Superintendent, Electronics Research Laboratory,
Box 2151, G.P.O., Adelaide, South Australia, 5001.

UNCLASSIFIED

TABLE OF CONTENTS

	Page No.
1. PRELIMINARY	1
2. INTRODUCTION	1
3. DESCRIPTION	1 - 2
4. OPERATION	2
5. PERFORMANCE	2
6. SPECIFICATION	2
7. CONCLUSIONS	2
8. ACKNOWLEDGEMENTS	3
 APPENDIX I PERFORMANCE MEASUREMENTS	 4 - 5

LIST OF FIGURES

1. 24 V d.c. Low Voltage Compensator (front view) N76/1259
2. 24 V d.c. Low Voltage Compensator (top view) N76/1260
3. Block diagram
4. Circuit diagram

1. PRELIMINARY

In today's complex electronic circuits, the demands made upon power supply and voltage regulator circuits can be quite severe. In most cases electronic circuits require stable and ripple free voltages to ensure their proper operation. From a knowledge of the characteristics of any likely source of power an appropriate voltage regulator can be designed to suit the worst case conditions. However, if the worst case condition does not occur frequently the all purpose system can be quite inefficient in terms of excess hardware and wasted power which is dissipated in the voltage regulator elements.

A typical example of this occurred recently during a field trial which involved the use of electronic equipment and some high power lights which were intermittently switched on and off. Because of the operating restrictions the equipment had to be used with long leads to a 24 V d.c. supply. Whenever the high power lights were used the nominal 24 V supply would drop to 19 V at the equipment. This was partly due to the poor regulation of the generating set as well as the voltage drop which occurred in the connecting leads. The result was that the electronic equipment would temporarily cease working until the supply had recovered.

A device for compensating for these low d.c. voltages has now been built and is described in this report.

2. INTRODUCTION

The method used for compensating for these low voltages consists of a small, self contained electronic unit which when required can be inserted between the source of energy and the actual load. The compensating unit is capable of supplying a nominal 24 V d.c. at currents up to approximately 10A and is able to do this for input voltages varying between 19 V to 24 V d.c. It operates by monitoring the output voltage and if this is low by converting some of the input power in a small d.c. to d.c. converter to a form which can then be added to the input supply thus ensuring a constant output voltage. Unlike most d.c. to d.c. converters which use the principle of obtaining all of the output power via a high frequency switching circuit and power transformer, the compensator unit described in this report (see figures 1 and 2) only transforms sufficient input power to make up the difference between the input and the output voltages.

3. DESCRIPTION

See figure 3 for the simplified block diagram of the 24 V Low Voltage Compensator. The three main components are the voltage sensing circuit, the ultrasonic d.c. to d.c. converter and the compensating circuit. Input and output voltage monitor circuits are also provided. Each of these drives a red, yellow and green light emitting diode display and gives an indication of the state of operation of the whole unit. The sensing terminals for the 24 V output voltage are isolated from the power output terminals and thus the whole unit can be used in a four wire set-up with remote output voltage monitoring.

The protective circuits consist of a maximum current limit (electronic shut-down as well as fuse link) and also input polarity protection against reverse connection of the input leads.

The whole unit may be remotely switched by a single low current connection to ground.

Two additional features were added to a later version of the 24 V Low Voltage Compensator. The first was the addition of an ammeter to indicate the actual load current. The second was the provision of a facility whereby the output voltage could be increased from 24 V to 28 V. This has proved extremely useful when operating service type 28 V equipment when only 24 V

supplies were available. The allowable drop in the input voltage was reduced slightly with 28 V at the output being obtained for input voltages as low as 20 V.

4. OPERATION

The basic operation of the compensator is as follows (see figure 4).

The voltage sense circuit monitors the output voltage and if this falls below the nominal 24 V setting a control signal is fed back to the ultrasonic d.c. to d.c. converter stage. In this circuit a 25 kHz oscillator drives a switching mode circuit which transforms some of the input power to the secondary circuit. The amount of power converted is modulated by the transistors TR7 and TR8 which feed the main transformer (T2). Ultrasonic operation was chosen because it is then possible to use relatively small ferrite cored driver and power transformers and the high frequency ripple is much easier to filter. With the availability of modern high speed low saturation voltage power transistors, the switching circuit is very efficient. In the compensating circuit the centre tapped secondary of the main switching transformer (T2) and a pair of fast recovery high current switching diodes form a standard full wave rectification circuit. The only difference from the usual secondary power supply configuration is the fact that the compensating circuit is connected in series with the input voltage to provide a "bucking" effect. Smoothing of the rectification ripple was achieved using small capacitors owing to the high frequency of operation. Some extra ferrite bead inductive elements were included in the output leads to reduce the amplitude of the switching spikes which may otherwise be transmitted to the load.

In the driver stage it was necessary to have a rather complex circuit in order to have efficient operation at the high current levels involved. The power transistors (TR6 and TR9) are driven well into saturation when they turn on and the reverse base charge is removed at the start of the next half cycle by actively driving the base emitter junctions into reverse bias. The base protection diodes are needed to limit the maximum reverse bias on the base emitter junction to 0.6 V.

5. PERFORMANCE

Various performance measurements were made on the prototype unit and these are summarised in Appendix I.

6. SPECIFICATION

Output voltage 24 V \pm 0.1 V for load currents up to 10 A.

Input voltage range (5 A load) 18 to 26 V.

(10 A load) 19 to 26 V.

Efficiency at full load current (10 A) 72%.

7. CONCLUSION

A device has been constructed and tested which should prove most useful when electronic equipment needs to be operated from poorly regulated 24 V d.c. sources. It has the added feature of being able to supply 28 V d.c. from a 24 V d.c. source. As far as the author is aware there is no similar device available with this type of performance.

8. ACKNOWLEDGEMENTS

The author would like to thank Mr N.K. Jones for the idea which was employed in this unit and Mr A. Dalton who did most of the construction of the final units.

APPENDIX I

PERFORMANCE MEASUREMENTS

I.1 Voltage regulation

Output voltage $24.0 \text{ V} \pm 0.1 \text{ V}$ nominal

Test condition $V_{\text{IN}} = 22.0 \text{ V}$

I_{OUT} 0 to 10 A

Actual results $I_{\text{OUT}} = 0 \text{ A}$ $V_{\text{OUT}} = 24.09 \text{ V}$

$I_{\text{OUT}} = 5 \text{ A}$ $V_{\text{OUT}} = 24.00 \text{ V}$

$I_{\text{OUT}} = 10 \text{ A}$ $V_{\text{OUT}} = 23.89 \text{ V}$

I.2 Output current

Unit is specified and tested to 10 A

Current limit set to 15 A

I.3 Input voltage range for output voltage

$V_{\text{OUT}} = 24 \text{ V} \pm 0.6 \text{ V}$ (High and low warning lights on)

$I_{\text{OUT}} = 0 \text{ A}$ V_{IN} 15.5 to 25.2 V

$I_{\text{OUT}} = 5 \text{ A}$ V_{IN} 17.61 to 25.85 V

$I_{\text{OUT}} = 10 \text{ A}$ V_{IN} 18.82 to 26.10 V

I.4 Efficiency versus output current

V_{IN} 21.81 21.66 21.32

I_{IN} 5 8.5 15.5

P_{IN} 109.1 184.1 330.5

V_{OUT} 24.03 23.99 23.99

I_{OUT} 3 5.3 10

P_{OUT} 72.1 127.1 238.9

EFFICIENCY 66% 69% 72%

I.5 Response to step input

A measurement of a step load on a poorly regulated source was made.

Step input V_{IN} 22.0 V to 17.9 V

Corresponding V_{OUT} 24.0 V to 23.95 V at $I_{\text{OUT}} = 5 \text{ A}$

Maximum deviation is 50 mV in 0.5 s.

I.6 Output ripple

$$I_{OUT} = 5 \text{ A}$$

25 kHz ripple magnitude 40 mV p-p

25 kHz spike magnitude 500 mV p-p

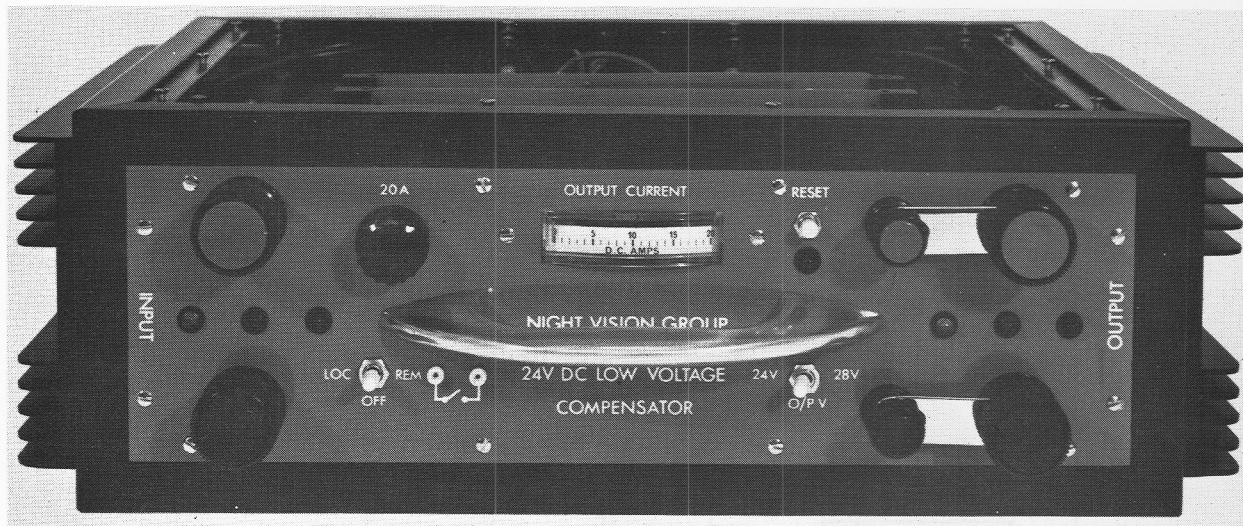

Figure 1. 24 V d.c. Low Voltage Compensator (front view) N76/1259

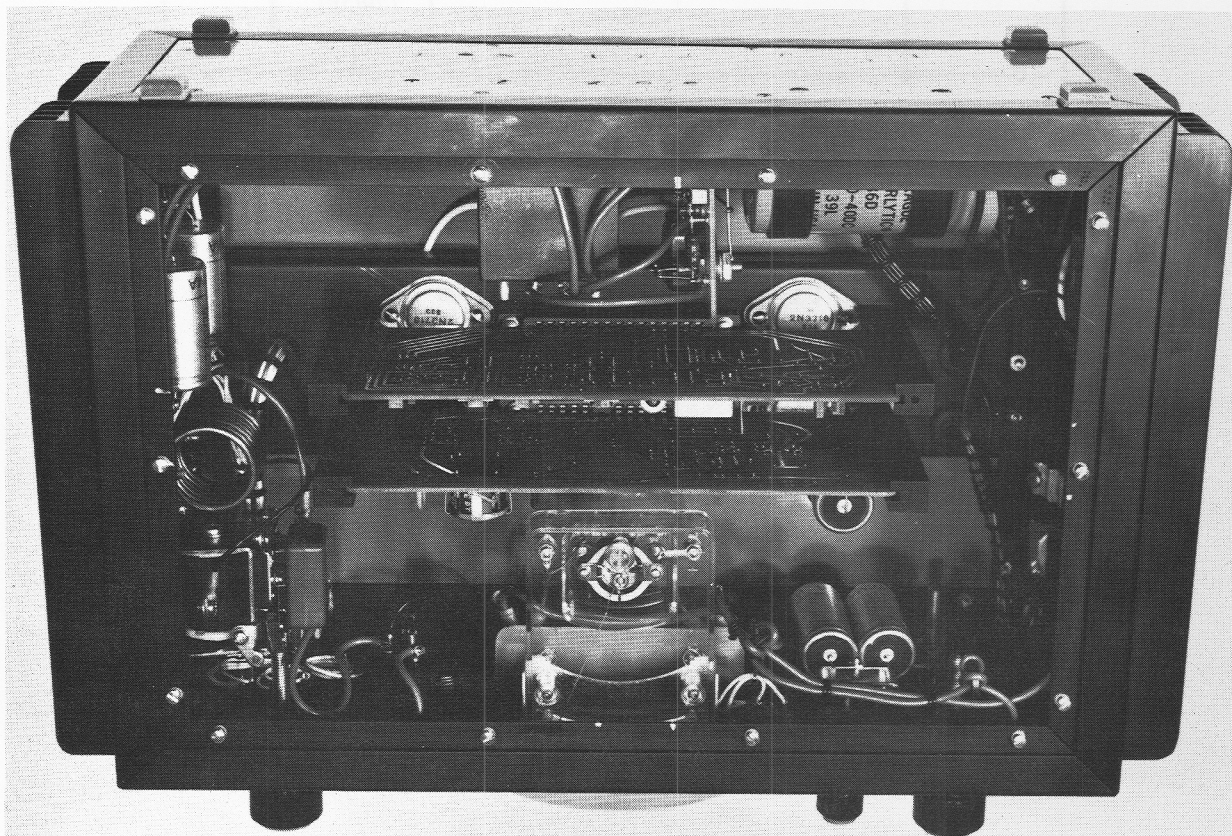

Figure 2. 24 V d.c. Low Voltage Compensator (top view) N76/1260

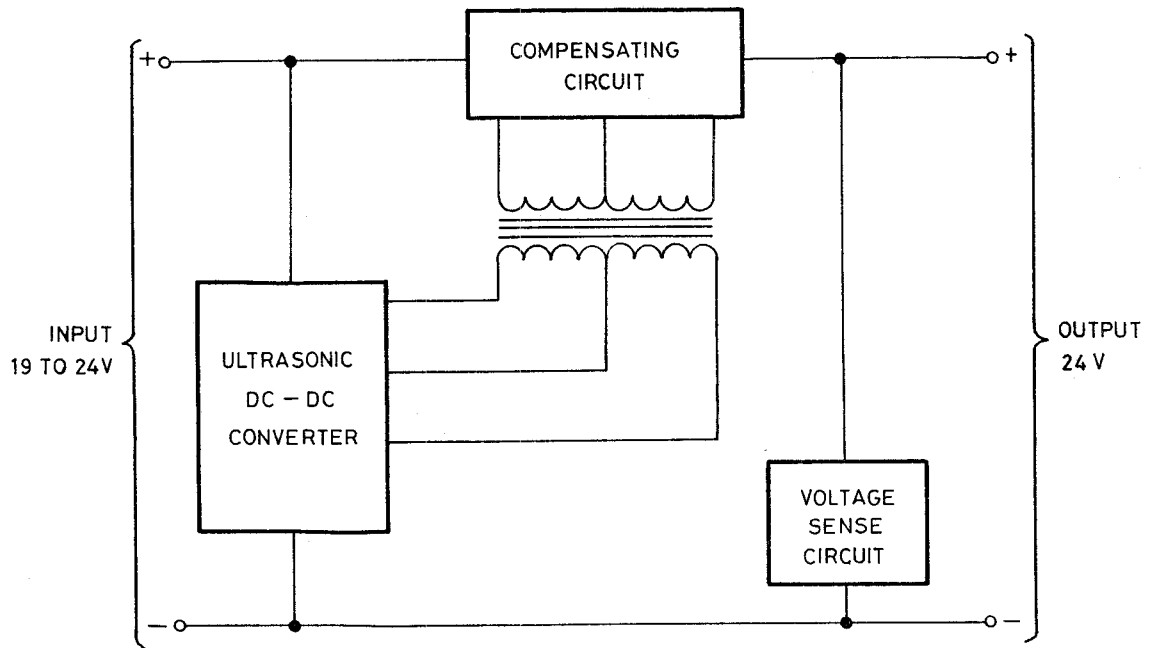

Figure 3. Block Diagram

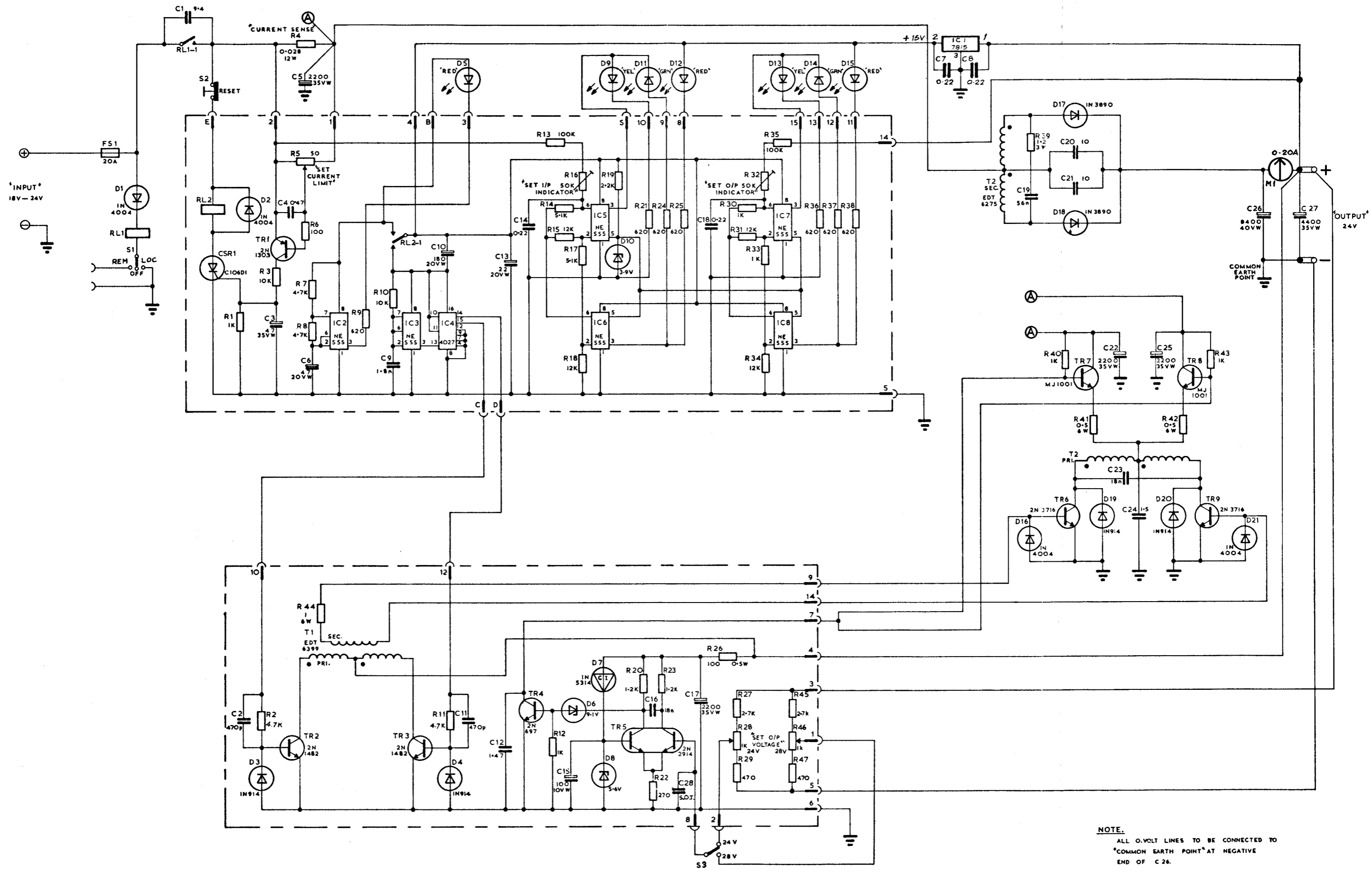

Figure 4. Circuit diagram

DOCUMENT CONTROL DATA SHEET

Security classification of this page

UNCLASSIFIED

1	DOCUMENT NUMBERS
AR Number:	AR-001-185
Report Number:	ERL-0008-TR
Other Numbers:	

2	SECURITY CLASSIFICATION
a. Complete Document:	UNCLASSIFIED
b. Title in Isolation:	UNCLASSIFIED
c. Summary in Isolation:	UNCLASSIFIED

3	TITLE
24 V d.c. LOW VOLTAGE COMPENSATOR	

4	PERSONAL AUTHOR(S):
B.W. Rice	

5	DOCUMENT DATE:
May 1978	

6	6.1 TOTAL NUMBER OF PAGES	14
	6.2 NUMBER OF REFERENCES:	

7	7.1 CORPORATE AUTHOR(S):
Electronics Research Laboratory	
	7.2 DOCUMENT SERIES AND NUMBER
Electronics Research Laboratory 0008-TR	

8	REFERENCE NUMBERS
a. Task:	73/02
b. Sponsoring Agency:	DEF.

9	COST CODE:
308784	

10	IMPRINT (Publishing organisation)
Defence Research Centre Salisbury	

11	COMPUTER PROGRAM(S) (Title(s) and language(s))

12	RELEASE LIMITATIONS (of the document):
Approved for Public Release.	

12.0	OVERSEAS	NO	P.R.	1	A	B	C	D	E
------	----------	----	------	---	---	---	---	---	---

Security classification of this page:

UNCLASSIFIED

13 ANNOUNCEMENT LIMITATIONS (of the information on these pages):

No Limitation.

14 DESCRIPTORS:

a. EJC Thesaurus
Terms

Circuits,
Power supply circuits
Voltage regulators
Voltage regulation
Electronic control
Automatic control equipment

b. Non-Thesaurus
Terms

Smoothing circuits

15 COSATI CODES:

0901
0905

16 LIBRARY LOCATION CODES (for libraries listed in the distribution):

SW SR SD AACA

17 SUMMARY OR ABSTRACT:

(if this is security classified, the announcement of this report will be similarly classified)

This report describes the operation and performance of a "24 V d.c. Low Voltage Compensator". This is a device which was built to overcome the problem of low input voltages to electronic equipment when operating them from poorly regulated supplies. It is very useful in trial situations when operating with long lead lengths. It operates by taking some of the input energy and converting it by way of ultrasonic frequencies to a d.c. voltage which is then added in series with the input in order to obtain a constant output voltage.