

AD A059183

DDC FILE COPY

3



This document has been approved for public release and sale; its distribution is unlimited.



DDC
 SEP 27 1978
 F

UNITED STATES AIR FORCE
 AIR UNIVERSITY
 AIR FORCE INSTITUTE OF TECHNOLOGY
 Wright-Patterson Air Force Base, Ohio

18 09 18 044

DDC FILE COPY

AD A059183

3

DDC
RECORDED
SEP 27 1978
F

6

A CONCEPTUAL MODEL OF THE DEPARTMENT
OF DEFENSE MAJOR SYSTEM
ACQUISITION PROCESS

1

Diann Lawson, GS-12, USAF
Damond L. Osterhus, Captain, USAF

DDC FILE - LSSR-20-78A

This document has been approved
for public release and sale; its
distribution is unlimited.

The contents of the document are technically accurate, and no sensitive items, detrimental ideas, or deliterious information are contained therein. Furthermore, the views expressed in the document are those of the author and do not necessarily reflect the views of the School of Systems and Logistics, the Air University, the United States Air Force, or the Department of Defense.

AFIT RESEARCH ASSESSMENT

The purpose of this questionnaire is to determine the potential for current and future applications of AFIT thesis research. Please return completed questionnaires to: AFIT/SLGR (Thesis Feedback), Wright-Patterson AFB, Ohio 45433.

1. Did this research contribute to a current Air Force project?

- a. Yes
- b. No

2. Do you believe this research topic is significant enough that it would have been researched (or contracted) by your organization or another agency if AFIT had not researched it?

- a. Yes
- b. No

3. The benefits of AFIT research can often be expressed by the equivalent value that your agency received by virtue of AFIT performing the research. Can you estimate what this research would have cost if it had been accomplished under contract or if it had been done in-house in terms of man-power and/or dollars?

a. Man-years _____ \$ _____ (Contract).

b. Man-years _____ \$ _____ (In-house).

4. Often it is not possible to attach equivalent dollar values to research, although the results of the research may, in fact, be important. Whether or not you were able to establish an equivalent value for this research (3 above), what is your estimate of its significance?

- a. Highly Significant
- b. Significant
- c. Slightly Significant
- d. Of No Significance

5. Comments:

ACCESS

_____ on

_____ on

_____ on

DISTRIBUTION AND CONTROL

A

Name and Grade

Position

Organization

Location

AFIT/LSGR
WRIGHT-PATTERSON AFB OH 45433

OFFICIAL BUSINESS
PENALTY FOR PRIVATE USE, \$300

POSTAGE AND FEES PAID
DEPARTMENT OF THE AIR FORCE
DoD-318



AFIT/LSGR (Thesis Feedback)
Wright-Patterson AFB OH 45433

☆ U.S. Government Printing Office: 1975-659-906
Region#5-11

UNCLASSIFIED

SECURITY CLASSIFICATION OF THIS PAGE (When Data Entered)

| REPORT DOCUMENTATION PAGE | | READ INSTRUCTIONS BEFORE COMPLETING FORM |
|---|-----------------------|---|
| 1. REPORT NUMBER LSSR 20-78A | 2. GOVT ACCESSION NO. | 3. RECIPIENT'S CATALOG NUMBER |
| 4. TITLE (and Subtitle) A CONCEPTUAL MODEL OF THE DEPARTMENT OF DEFENSE MAJOR SYSTEM ACQUISITION PROCESS | | 5. TYPE OF REPORT & PERIOD COVERED Master's Thesis |
| | | 6. PERFORMING ORG. REPORT NUMBER |
| 7. AUTHOR(s) Diann Lawson, GS-12, USAF Damond L. Osterhus, Captain, USAF | | 8. CONTRACT OR GRANT NUMBER(s) |
| 9. PERFORMING ORGANIZATION NAME AND ADDRESS Graduate Education Division School of Systems and Logistics Air Force Institute of Technology, WPAFB, OH | | 10. PROGRAM ELEMENT, PROJECT, TASK AREA & WORK UNIT NUMBERS |
| 11. CONTROLLING OFFICE NAME AND ADDRESS Department of Research and Administrative Management AFIT/LSGR, WPAFB OH 45433 | | 12. REPORT DATE June 1978 |
| | | 13. NUMBER OF PAGES 124 |
| 14. MONITORING AGENCY NAME & ADDRESS (if different from Controlling Office) | | 15. SECURITY CLASS. (of this report) Unclassified |
| | | 15a. DECLASSIFICATION/DOWNGRADING SCHEDULE |
| 16. DISTRIBUTION STATEMENT (of this Report) Approved for public release; distribution unlimited. | | |
| 17. DISTRIBUTION STATEMENT (of the abstract entered in Block 20, if different from Report) | | |
| 18. SUPPLEMENTARY NOTES APPROVED FOR PUBLIC RELEASE AFR 190-17. <i>J. F. Guess</i> JERRAL F. GUESS, CAPT, USAF Director of Information | | |
| 19. KEY WORDS (Continue on reverse side if necessary and identify by block number) Acquisition; Procurement, Major System Acquisition | | |
| 20. ABSTRACT (Continue on reverse side if necessary and identify by block number) Thesis Chairman: Donald R. Edwards, Lt Col, USAF | | |

DD FORM 1473 1 JAN 73

EDITION OF 1 NOV 65 IS OBSOLETE

UNCLASSIFIED

SECURITY CLASSIFICATION OF THIS PAGE (When Data Entered)

UNCLASSIFIED

SECURITY CLASSIFICATION OF THIS PAGE(When Data Entered)

The Department of Defense's weapon system acquisition process has come under increasing scrutiny by Congress in the last two decades because of increased cost and inadequate performance of its new weapon systems. Many studies have been made on specific aspects of the acquisition process to improve acquisition strategies. As a result, constant changes have been made in the process in an attempt to eliminate problems. However, none of the changes have significantly improved the process. The problem of developing and implementing effective solutions to the acquisition process appear to stem not from valid research but from a lack of understanding of the total system and the environment in which the process operates. The Federal Procurement Institute expressed the desire for a model that would depict the contextual setting of the acquisition process to aid in formulating changes to the process using current research and in directing future research. The authors present a conceptual model of the DoD acquisition process that incorporates the contextual setting of the process, describes the major interactive factors, and captures the influences of these factors on each other as well as on the entire process.

UNCLASSIFIED

SECURITY CLASSIFICATION OF THIS PAGE(When Data Entered)

LSSR 20-78A

A CONCEPTUAL MODEL OF THE DEPARTMENT
OF DEFENSE MAJOR SYSTEM ACQUISITION PROCESS

A Thesis

Presented to the Faculty of the School of Systems and Logistics
of the Air Force Institute of Technology

Air University

In Partial Fulfillment of the Requirements for the
Degree of Master of Science in Logistics Management

By

Diann Lawson, BS
GS-12, USAF

Damond L. Osterhus, BS
Captain, USAF

June 1978

Approved for public release;
distribution unlimited

This thesis, written by

Ms Diann Lawson

and

Captain Damond L. Osterhus

has been accepted by the undersigned on behalf of the
faculty of the School of Systems and Logistics in
partial fulfillment of the requirements for the degree of

MASTER OF SCIENCE IN LOGISTICS MANAGEMENT
(ACQUISITION LOGISTICS MAJOR)

DATE: 14 June 1978

COMMITTEE CHAIRMAN

TABLE OF CONTENTS

| | Page |
|--|------|
| LIST OF FIGURES | v |
| Chapter | |
| 1. INTRODUCTION | 1 |
| Problem Statement | 2 |
| Problem Justification | 4 |
| Research Objective | 5 |
| Scope of the Research Effort | 5 |
| 2. RESEARCH METHODOLOGY | 7 |
| Introduction | 7 |
| Data Gathering Effort | 7 |
| Formal data search | 8 |
| Informal data | 9 |
| Summary of data gathering effort | 10 |
| Modeling Efforts | 11 |
| System dynamics modeling | 11 |
| Information feedback system | 13 |
| System structure | 18 |
| Amplification in policies | 20 |
| Delays | 21 |
| Flow diagrams | 26 |
| Summary of system dynamics modeling | 26 |
| Modeling steps | 27 |
| Causal loop diagramming | 28 |
| Summary of modeling effort | 37 |
| Model presentation | 37 |
| 3. SECTOR DESCRIPTION AND CAUSAL LOOP ANALYSIS | 39 |
| Introduction | 39 |

| Chapter | Page |
|--|------|
| Contextual Setting of the Acquisition | |
| Process | 40 |
| System Sectors | 42 |
| Sector interactions | 43 |
| Causal Loop Analysis | 48 |
| Casual loop diagram | 50 |
| Causal Loop System Behavior | 76 |
| Summary of Causal Loop Analysis | 86 |
| 4. FLOW DIAGRAMS | 88 |
| Resource Allocation Flow Diagram | 95 |
| Threat Reduction Flow Diagram | 103 |
| Growth Flow Diagram | 107 |
| System Flow Diagram and Summary | 110 |
| 5. CONCLUSIONS AND RECOMMENDATIONS | 113 |
| Conclusions | 113 |
| Recommendations for Further Research | 116 |
| SELECTED BIBLIOGRAPHY | 119 |

LIST OF FIGURES

| Figure | Page |
|---|------|
| 1. Information Feedback Loop | 15 |
| 2. Information Feedback System | 17 |
| 3. Information Feedback System with Delays . . | 24 |
| 4. Positive Causal Links | 29 |
| 5. Positive Causal Loop | 30 |
| 6. Negative Causal Link | 33 |
| 7. Negative Causal Loop | 33 |
| 8. Causal Loop Model | 36 |
| 9. Sector Interaction Diagram | 44 |
| 10. System Causal Loop Diagram | 51 |
| 11. Threat Perception-Threat Reduction Causal Links | 53 |
| 12. Spending Pressure Causal Links | 57 |
| 13. Resource Allocation Causal Links and Loops | 63 |
| 14. Weapons Production-Threat Reduction Causal Loops | 66 |
| 15. Technology-Threat Reduction Causal Loops | 69 |

| Figure | Page |
|--|------|
| 16. Technological Opportunity Growth Causal Loops | 73 |
| 17. Causal Loop Delays | 81 |
| 18. Resource Allocation Flow Diagram | 89 |
| 19. Threat Reduction Flow Diagram | 90 |
| 20. Growth Flow Diagram | 91 |
| 21. System Flow Diagram | 92 |

Chapter 1

INTRODUCTION

The Department of Defense's (DoD) weapon system acquisition process has come under increasing scrutiny by Congress in the last two decades (14:1). The large dollar value of the weapon system acquisitions and the costly errors made in those acquisitions have made the process a prime target for this scrutiny.

The results of this attention have been a growing number of studies and investigations into the acquisition process and its problems. In this decade, both governmental and private efforts have been made to examine the way the government determines the need for defense weapon systems, and how it actually procures them. Two prime examples of these efforts are: the Commission on Government Procurement report on the "Acquisition of Major Systems 14," and Arming America (5).

Both of these studies examined in detail the total major weapon system acquisition process. A major weapon system is one whose costs are anticipated to exceed specified limits.* Each of these studies reported significant problems with the process, and made recommendations for their correction. In addition to these "system" studies, numerous other studies have been made on specific aspects of the acquisition process. An example of one of these "aspect-type" studies is the General Accounting Office's (GAO) report on "The Process for Identifying Needs and Establishing Requirements for Major Weapon Systems in the Department of Defense [19]." This GAO study addressed only the methods used within DoD to identify when a major weapon system is needed and how that need is translated into a requirement for a piece of hardware.

Problem Statement

Despite the plethora of research information produced by the studies and reports, the resulting corrective actions have failed to eliminate the serious

*Presently, weapon systems are designated as major if it is anticipated that research development, test and evaluation (RDT & E) costs will exceed \$75 million, or that production costs will exceed \$300 million (15:2).

problem areas of the acquisition process. The B-1 strategic bomber, cancelled by President Carter in the summer of 1977, was an example of a system whose costly acquisition was inappropriate for the existing political, economic, and social environment. Most of the problems apparent today in system acquisitions are the same as those problems experienced in the 1960 era acquisitions. The C-5A cargo aircraft and the F-111A fighter bomber are well publicized examples of such troublesome 1960 era acquisitions. Constant changes in acquisition strategy have been made in an attempt to eliminate the problems of a previous strategy; e.g., fly-before-buy, total package procurement, two-step procurement, and life cycle cost/design-to-cost have all been used over the past 20 years as acquisition strategies. None has significantly improved the process (8). Cost overrun, now called cost growth, and inappropriate/ineffective system acquisition are still problems and are topics of strong public interest (13).

The problem of developing and implementing effective solutions to acquisition process difficulties appears to stem not from a lack of valid research data, but from a lack of understanding of the total system and

the environment in which the acquisition process operates. That is, no model has been developed that integrates what is known about the workings of the acquisition process with the total conditions under which that process takes place.

Problem Justification

The lack of such a model has been recognized by the Federal Procurement Institute (FPI). In a draft study plan of its Information Management Program, FPI expressed its desire for a conceptual model of the acquisition process (18). The expressed purpose of the desired model was "to depict a contextual setting of acquisition issues [18:1]." Additionally, FPI desired that the model "assist in problem identification and evaluation, discipline the conduct of research to account for the interdependencies and interrelationships of acquisition issues, and provide a basis for evaluating research recommendations [18:1]."

The authors contacted Dr. Robert Judson, the individual with prime responsibility for the modeling task, and were encouraged to independently develop such a conceptual model (7).

Research Objective

Based on the apparent need for better understanding of the DoD major system acquisition process and the expressed FPI desire, the objective of this research was to develop a conceptual model of the DoD major system acquisition process. Important aims in this effort were to develop a model that would:

1. Make it possible for participants in the acquisition process to understand the role of the process, and what factors are at work in its operation.

2. Act as a framework into which currently available research data may be integrated to expand and refine the model.

3. Provide insight into areas that are as yet unexplored but appear to be influential in the workings of the system; i.e., assist in directing future research.

Scope of the Research Effort

As with all research, time and resources limit the scope of the effort. This research effort was consciously limited to developing a conceptual model only; one that dealt in aggregated and generic aspects of the acquisition process. No attempt was made to computerize

the model, although a modeling technique was purposely selected that readily lends itself to computerization. An explanation of that technique and the overall research method follows.

Chapter 2

RESEARCH METHODOLOGY

Introduction

The methodology used in this research effort consisted of two basic actions: the data gathering effort, and the conceptual modeling effort. The objective of the data gathering effort was to learn about both the DoD major system acquisition process, and the environment within which it functions. The conceptual modeling effort represented the transformation of what had been learned into the model.

The remainder of this chapter deals with the way these basic actions were executed, and includes an overview of the specific modeling technique used.

Data Gathering Effort

The data gathering effort resulted in both formal and informal data being obtained. The formal data search was a concerted effort on the authors part to review the literature available on the acquisition process and its

environment. The informal data resulted from the critical assessment of the various data sources with which there was contact; e.g., newspapers, television and radio, and magazines. Both types of sources were used to accomplish the research objective.

Formal data search. The formal data search consisted of the actions listed below. Some of these actions were partially accomplished through completion of required course work for the Acquisition Logistics curriculum at the Air Force Institute of Technology. The data gathering actions taken were:

1. A review of government regulatory documents on the acquisition process. The major documents reviewed were: DoD Directive 5000.1, "Major System Acquisitions [15];" DoD Directive 5000.2, "Major System Acquisition Process [16];" and Office of Management and Budget (OMB) Circular A-109, "Major System Acquisitions [3]."

2. A review of governmental and non-governmental studies of the acquisition process. The types of material reviewed were: the GAO report on "The Process for Identifying Needs and Establishing Requirements for Major Weapon Systems in the Department of Defense [19]," the

Commission on Government Procurement report on "Acquisition of Major Systems 14," and J. Ronald Fox's Arming America (5).

3. An investigation into the business practices of the DoD, and the government in general. Specifically examined were materials relating to DoD's Planning, Programming, and Budgeting System (PPBS), and those relating to the methods used to purchase defense articles.

4. A review of micro and macro economic principles as they relate to the government, the market with which it interacts, and the economic conditions under which that interaction takes place.

5. A review of generally accepted management structure and management behavior theories.

The above reviews were selected to provide a view of the acquisition process in its environment. Reviews were conducted with the objective of capturing the essence rather than the detail of the subject area.

Informal data. As a result of the formal data collection effort, informal data collection also took place. Though less structured than the formal effort, a critical evaluation was made of the events and circumstances reported in

newspapers, on radio and television, in magazines, and by informal contact with other students, faculty, and those who have been involved in some aspect of the acquisition process. These sources collectively added to the total data base used to formulate the conceptual model. The important value of the informal data was in its ability to reflect the perceptions of both the military and non-military sectors. Such perceptions influence decisions and actions. Examples of the types of informal data collected were: Congressional actions on defense measures, public pressure for non-defense federal programs, defense program expenditures and reaction to same, and reported Soviet/Warsaw Block activities and defense capabilities.

Summary of data gathering effort. The data gathering effort resulted in a data base consisting of two types of data: the formal literature review data, and the informal data from critical assessment of other data sources. Both types of data were necessary to the construction of the conceptual model. The data gathering effort and the modeling effort are separated for the sake of description, but the actual research process involved constant interaction and overlap between these efforts.

Modeling Efforts

The modeling technique used to develop the conceptual model was a cybernetic/information feedback system modeling approach. The primary philosophical guidance for this approach came from Decision and Control by Stafford Beer (7), and Management Systems: Conceptual Considerations by Schoderbek, et al (11). The modeling technique chosen was the system dynamics modeling technique of Jay W. Forrester presented in Industrial Dynamics (4).

The system dynamics technique was selected because it was well suited for modeling policy-decision systems and had the potential for computerization. This potential for computerization was determined to be essential to make further use of the conceptual model possible.

System dynamics modeling. The system dynamics modeling technique is based on studying the information-feedback characteristics of a system. Such a study reveals how a system's organizational structure interacts with its policy/decision making mechanisms to influence the overall activity of the system (4:13). In essence, the study of information feedback systems reveals the way information

is used in an attempt to control the system's behavior
(4:15).

The major premises of the system dynamics technique are as follows:

1. Decisions in management and economics take place in a framework that belongs to the general class known as information-feedback systems.
2. Our intuitive judgment is unreliable about how these systems will change with time, even when we have good knowledge of the individual parts of the system.
3. Model experimentation is now possible to fill the gap where our judgment and knowledge are weakest--by showing the way in which the known separate system parts can interact to produce unexpected and troublesome over-all system results.
4. Enough information is available for this experimental model building approach without great expense and delay in further data gathering.
5. The "mechanistic" view of decision making implied by such model experiments is true enough so that the main structure of controlling policies and decision streams of an organization can be represented.
6. Our industrial systems are constructed internally in such a way that they create for themselves many of the troubles that are often attributed to outside and independent causes.
7. Policy and structure changes are feasible that will produce substantial improvement in industrial and economic behavior; and system performance is often so far from what it can be that initial system design changes can improve all factors of interest without a compromise that causes losses in one area in exchange for gains in another [4:13-14].

Information feedback system. As can be seen from the above premises, the key concept of the system dynamics technique is the information feedback system. Such a system 'exists whenever the environment leads to a decision that results in action which affects the environment and thereby influences future decisions [4:14]."

The basic element of the information feedback system is the information feedback loop. The components of the basic feedback loop are: a decision mechanism that controls the flow of items such as materials, money, or personnel much as a water valve controls the flow of water; an accumulator of the flow, conceptually similar to a water tank; and a flow of information to the decision mechanism reflecting changes in the loop's accumulator, similar to the reading on a water level gauge. A common example of a feedback loop is the thermostatically controlled temperature environment of most homes. The thermostat is the decision mechanism, and the temperature in the house is the accumulation of the heated or cooled air flows that are controlled by the thermostat. The thermostat receives constant information about the temperature in the house through its sensing device. This information feedback is used to control the amount

of hot/cold air flow (in most cases this flow is full on or full off).

More than one flow of information may exist in even simple feedback loops. Figure 1 is a symbolic representation of such a loop. (The symbols used in this figure are the standard system dynamics symbols that are used throughout the rest of this effort). The loop shown is a policy model as opposed to the physical model described above. The loop itself represents a simple description of the function of a nation's weapon system acquisition process. The government is shown as the decision mechanism that controls resources flowing into an accumulator called total capability. This total capability is pictured as the total number of weapon systems possessed by the nation. The flow controlled by the government is represented by the number of weapon systems produced per period of time. The government controls the flow as a result of information it receives from the environment on the capability of an enemy, and information it receives on its own capability. By comparing the two pieces of information, the government makes decisions to adjust the total capability by increasing or decreasing the capability flow. The disparity

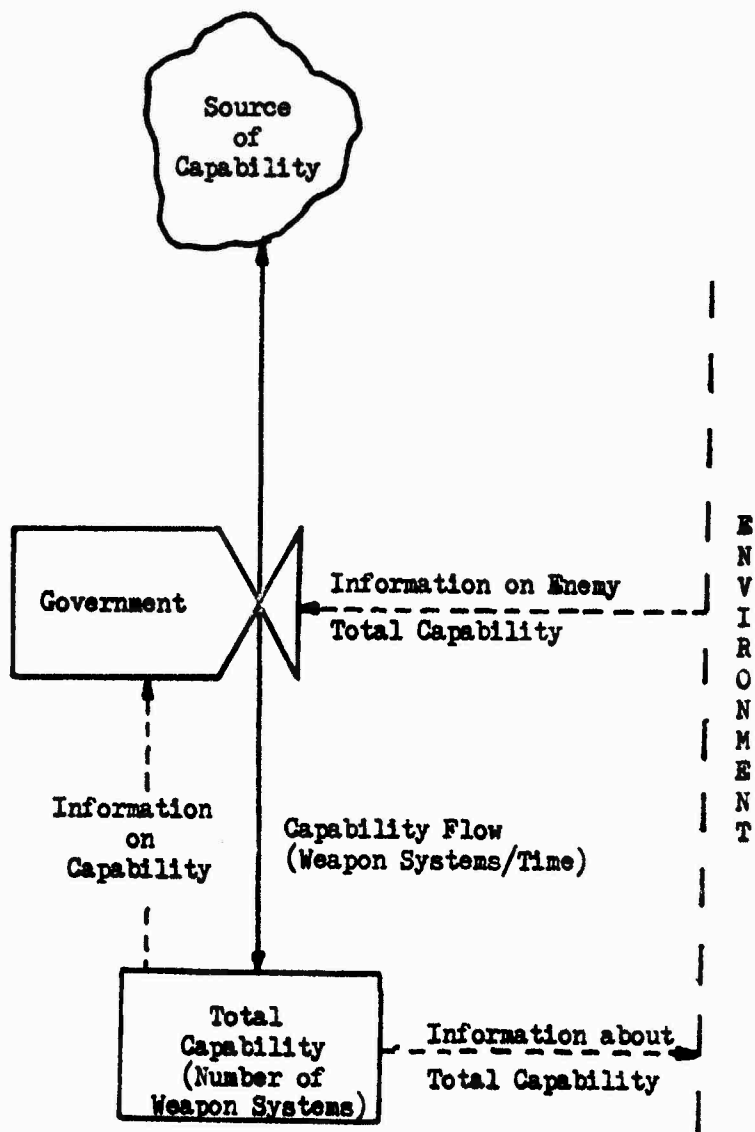

Figure 1
Information Feedback Loop

between the capabilities of a government and its enemy represents "threat" in a simple militaristic sense. Information about total capability is also shown flowing to the environment. This information flow is the counterpart of the information flow of enemy total capability to the government side; i.e., the intelligence information effort.

As can be seen from the example above, the simple information feedback loop is capable of capturing many concepts and characteristics of a system. However, to totally capture the characteristics of a system and its environment many such loops may be required. Figure 2 shows an expansion of the Figure 1 loop into an information feedback system (two or more loops). This was done by adding an information feedback loop that represents the actions of an enemy. The two loops are exactly the same in structure, yet by joining them together an increase in the total conceptualization of the system is possible. Additional insight into the system's characteristics also can be gained. Basically, in this example the boundary of the system was expanded to include the enemy activity, thereby increasing the ability to understand better the characteristics of the system.

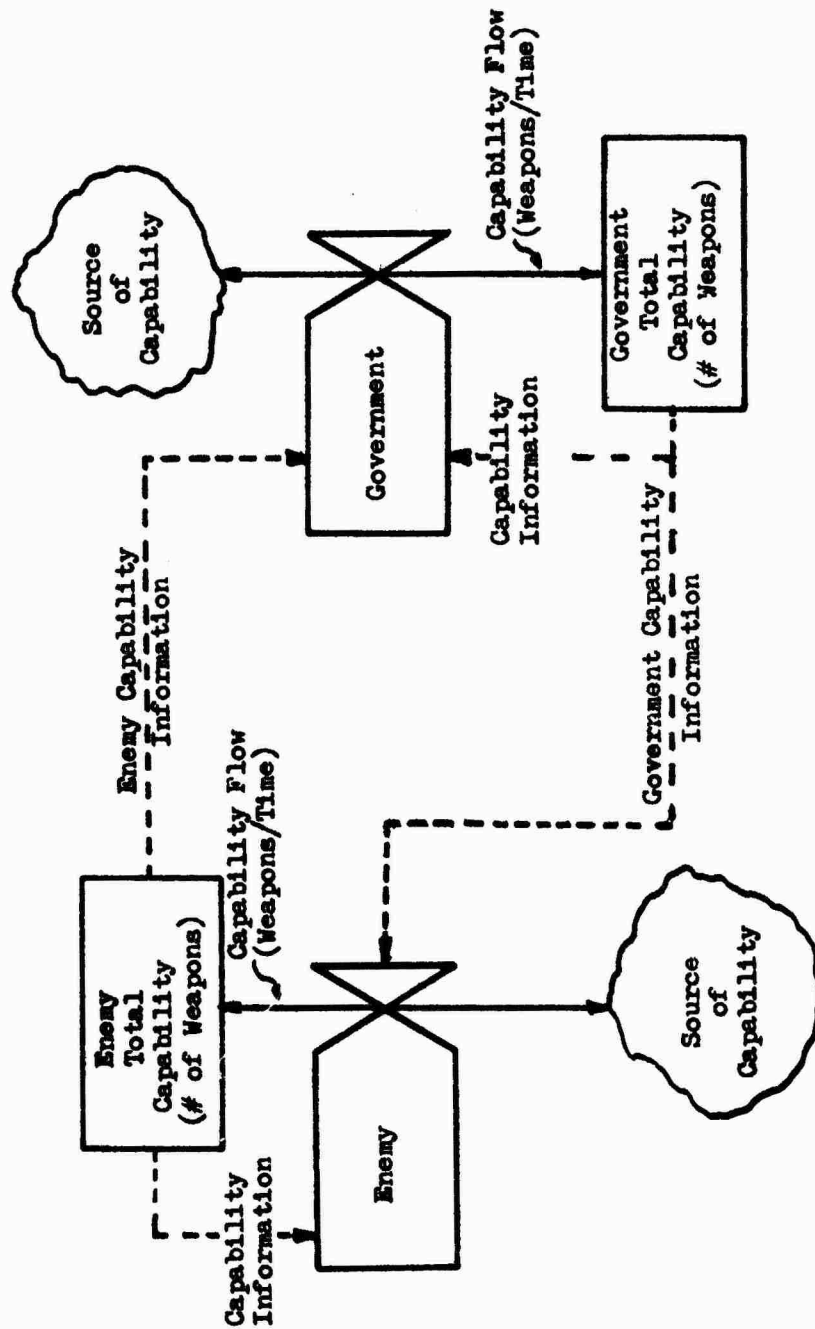

Figure 2
Information Feedback System

In the Figure 2 feedback loop system an arms-race phenomenon is depicted. If both the government and its enemy respond to increases in the other's total capability by subsequently increasing their own capabilities, then a continuing increase in both total capabilities results. However, the specific policies of each side have a great deal to do with the extent to which the total capabilities are increased.

The advantage of the information feedback system approach is that it can show how actions taken by the decision mechanisms in accordance with established policy can lead to unstable fluctuations in the overall performance of the system (4:15). In using the system dynamics/information feedback system approach there are three characteristics of a system that are critical to capturing a system's behavior. These characteristics are: structure, amplification, and delays.

System structure. An information feedback system's structure is defined as the way in which a system's elements are connected; i.e., how they interact. As shown in the preceding examples, structure is generally a network of accumulators connected together by controlled flows (4:67).

The accumulators, known as "levels," represent accumulations of system flows. The levels are representative of the states of system components at any one instant in time (4:68). For example, in Figure 2 the total capability of either the government or its enemy is a level. The total capability reflects the sum of all capability flow decisions at any point in time. That is, if total capability is represented by a total number of weapon systems, the level of total capability at any instant is a result of the decisions affecting the systems produced per time period up to that instant. In the example, the flow of capability in weapon systems/time is representative of "controlled flow" and is known as a rate.

Rates are the instantaneous flows between levels. They are a result of decision mechanism action. In system dynamics modeling, the decision mechanism acts on the basis of information provided. It does so in accordance with some policy governing how information is to be transformed into action. Such a policy is known as a decision function, and its resulting action is a rate.

In summary, the structure of the system is the sum total of the levels, rates, and information flows, and

how they are connected. System policies control the rates through the decision functions. The rates, in turn, impact on the levels, and the information about the levels is fed back to the decision functions. Policies are very important factors in determining the behavior of the overall system, and amplification in policies is a system characteristic concerning this most important factor.

Amplification in policies. Amplification in policies occurs "when an action is more forceful than might at first seem to be implied by the information inputs to the governing decisions [4:15-16]." Such forceful actions result in rates that may be inappropriate for system control. As a consequence, out of control or fluctuating system behavior may result. The overall impact of amplification on a system is governed, however, by the total system characteristics.

An example of amplification in policies can be seen using the arms race scenario presented in the discussion of the Figure 2 feedback system. If the policy of both decision functions is to double the weapon system production rate for every reported 10% increase in the total capability of the other, then the rate at which

both sides increase their production rates would grow rapidly, and finally the production rates would reach the maximum production capability of each. The system would be out of control until the maximum production capabilities of each side were reached. The system would then stabilize at the maximum production rates. This stabilized condition is a result of an "implicit decision" of the system itself; that is, something inherent in the system is overriding or limiting the effects of the amplified policies. Implicit decision is a factor to consider when dealing with the amplification characteristic.

Sometimes implicit decisions are caused when the decision function attempts to change a rate, and the system cannot respond instantly to the attempted change. Using the arms race example, the time needed to increase production capacity for either side may be the reason for the "stalled" production rate (lack of resources could be another). This effect of time on a system is representative of the third characteristic of an information feedback system; the characteristic of delay.

Delays. Delays are essentially the time lags that exist in a system. They may be the time lags between a decision

to act and the completion of that action, as in the stalled production rate example; or time lags in the creation of information and its receipt. Additionally, delays may occur as a result of turning information into decisions. Delays exist in all systems, and it is the effect of the delays that causes systems to exhibit their instabilities (4:62). Therefore, a knowledge of delays becomes crucial to understanding the dynamic nature of information feedback systems (4:86).

Delays affect the flows of a system, and take on many forms. For example, the delay in receiving a single load of lumber is one in which the time from submission of the order until receipt of the lumber is characterized by a "no lumber" condition, while the time after delivery is an "all lumber" condition. An almost instantaneous increase is experienced some time after the increase is desired. On the other hand, the time delay to receive all of a shipment of lumber (more than one load) is characterized by an increasing amount of lumber over a period of time until all the lumber is received. The specific form of the delay has an effect on the behavior of the system, but not as much as the presence or absence of the delay itself (4:419-421).

Figure 3 depicts the arms race example shown in Figure 2 with delays inserted in the flows. Delays are added to the capability flows to indicate the time delay that occurs between the decision to increase the capability level (by increasing weapons production), and actually achieving that increased production rate. The inputs to these delays are labeled weapon system starts, while the outputs are labeled weapon systems completions. The addition of the delays captures the realities of weapon system production.

Delays are also added to the flows of information going from the capability levels to the opposing side decision functions. This reflects the time necessary to obtain intelligence information about the level of capability of an adversary. No delays are added to the information flows from the levels of total capability to their respective decision functions. This reflects that the delays in knowing the level of one's own capability is very short relative to the other delays in the system and as such, they are not necessary to the model. The decision to exclude a delay in a system dynamics model is judgmental and is usually based on the relative magnitude of the delay times involved.

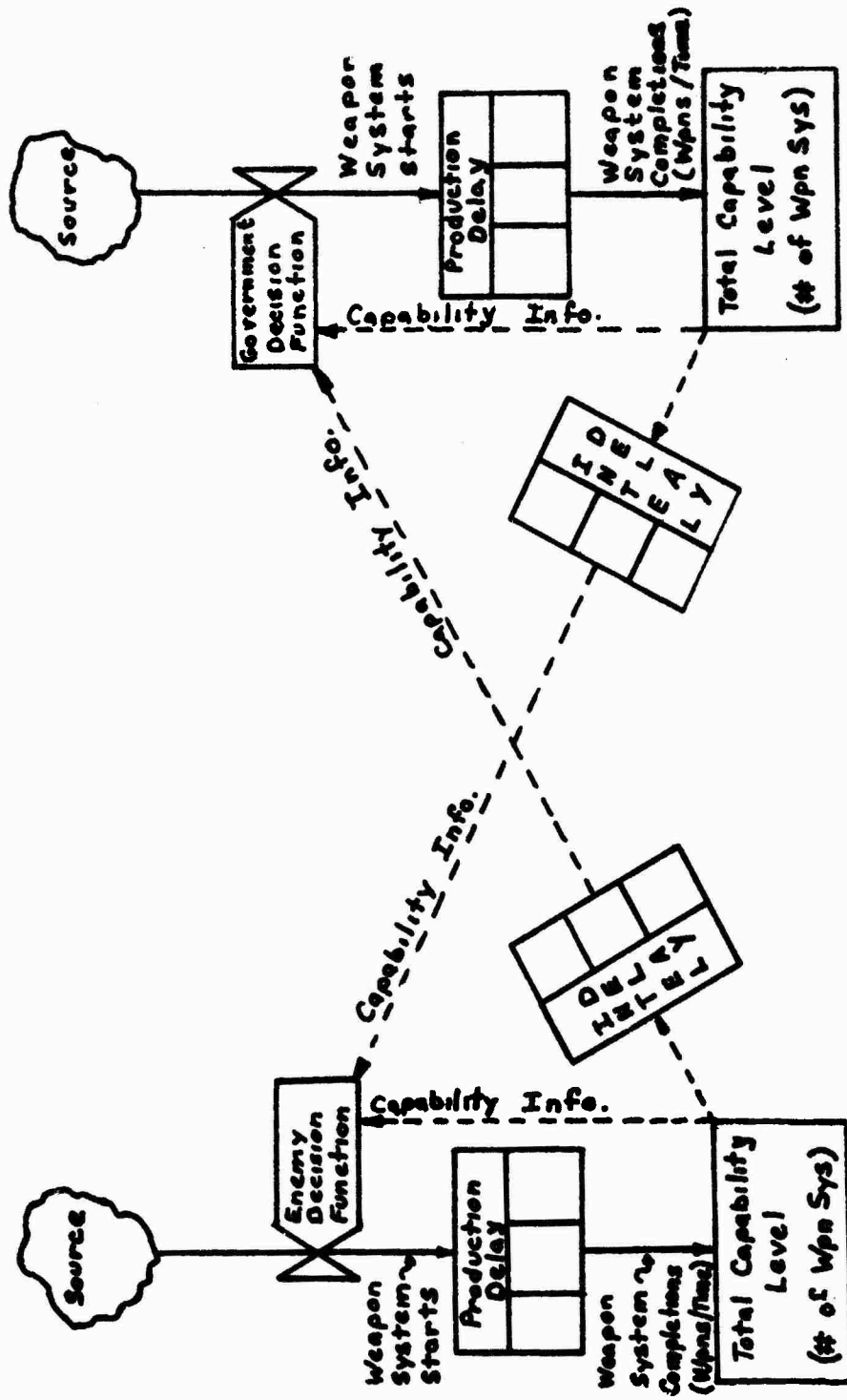

Figure 3
Information Feedback System With Delays

Because of the delays, the behavior of the Figure 3 system can be drastically different from the Figure 2 system behavior, depending on the magnitude and form of the delays. For example, if there is a substantial delay in the receipt of intelligence information by the enemy side decision function, (relative to the delay in the receipt of intelligence information by the government side decision function), then the enemy decision function will lag in responding to any increases in the "government" side total capability level. The ability of the government side to detect more quickly the level of total capability of the enemy allows the government to adjust its weapon system starts rapidly. The fluctuation in government side weapon system starts affects weapon system completions through a delay. The completions, in turn, affect the government total capability level. At this point, it is conceivable that the production rates could wildly fluctuate after a period of time. This type of behavior is in sharp contrast to the rapid, yet steady, growth of production rates reflected in the systems without delays.

From the comparison of the behaviors of the Figures 2 and 3 information feedback systems, it can be seen that the delays are an important characteristic of a system dynamics model.

Flow diagrams. In the figures presented thus far, the symbols for the levels, decision functions, rates, information flows, and delays have been combined to form a diagrammatic representation of the information feedback systems. These diagrams are called flow diagrams, and are the method used to represent system dynamics models. It was in this form that the conceptual model of the acquisition process was developed.

Summary of system dynamics modeling. The system dynamics modeling technique views a system as information feedback loops interconnected with each other and to the environment. The basic characteristics of such information feedback systems are: structure, amplification, and delays. All are important elements when developing a system dynamics model. System dynamics models are portrayed pictorially by means of flow diagrams, and therefore the task of developing a system dynamics model is that of translating what is known about the system into flow diagrams.

Modeling steps. The steps used in this research effort to translate the data to a system dynamics model are listed below. In addition to the system dynamics approach, a method known as causal loop diagramming (6) was used in the development of the flow diagrams. This technique is explained following the discussion on the modeling steps. The modeling steps used were:

1. To segregate and define the major elements (sectors) of the acquisition process.
2. To develop concepts of how these sectors interact.
3. Based on the concepts, to develop causal relationships between sector elements.
4. To represent the causal relationships using causal loop diagrams.
5. To translate the causal loops into flow diagrams.
6. To refine the flow diagrams into the final model.

The first two steps of this process involved conceptualizing and categorizing the data. The remaining three steps involved operationalizing these concepts into a model. By their very nature there was much interplay

and interaction between steps, as well as interplay with data gathering.

Causal loop diagramming. Causal loop diagramming was used to assist in operationalizing the causal relationships that were noted between the sector elements.

This technique, also known as causal loop analysis, "begins with the identification of the relationships between individual pairs of variables [6:11]." These relationships, called causal links, are then combined into looping structures called causal loops. As a result of the combination of the links, the causal loops reflect the basic feedback relationships between the system variables.

Figures 4 and 5 depict four examples of causal links, and the causal loop formed when they are combined. The system used to derive the links is the arms race example depicted previously. The relationship reflected in the causal links is a positive one. That is, the two variables connected by the curved arrow act in a corresponding manner. When the variable at the tail end of the arrow increases, the variable at the arrowhead end is perceived as increasing also. If the tail end variable decreases, the arrowhead end is seen to

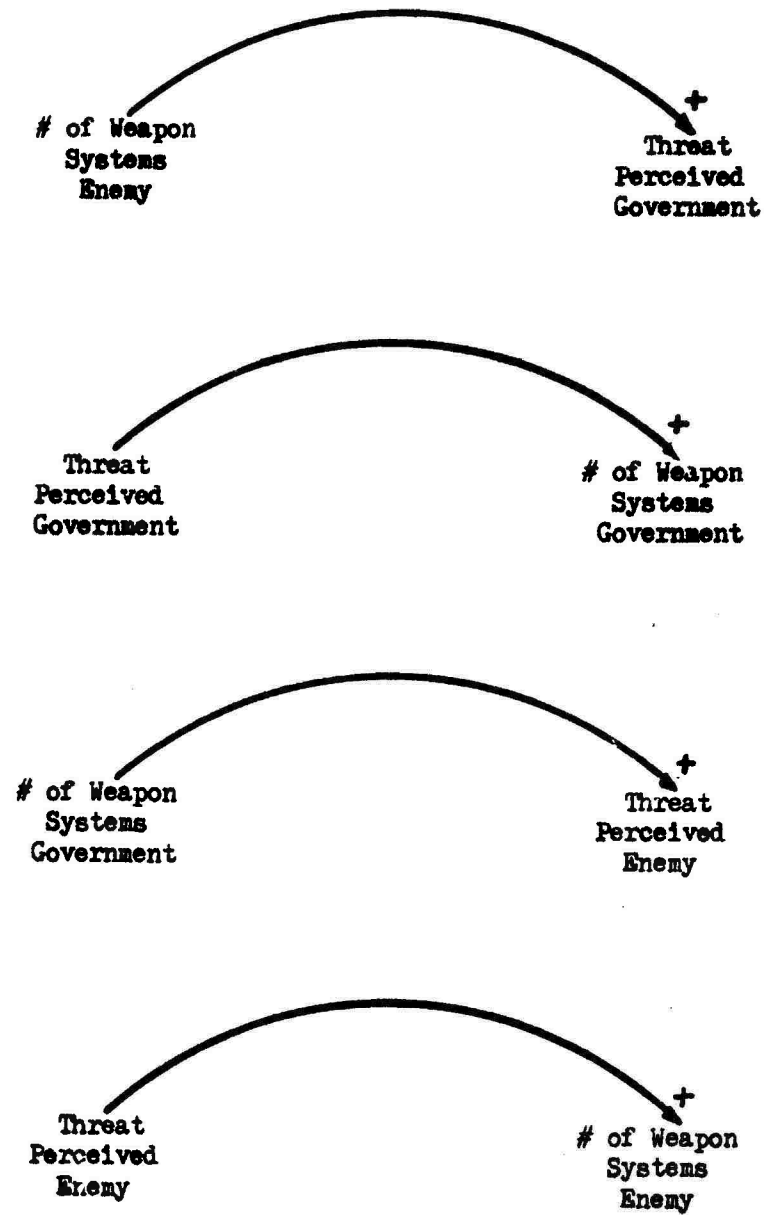
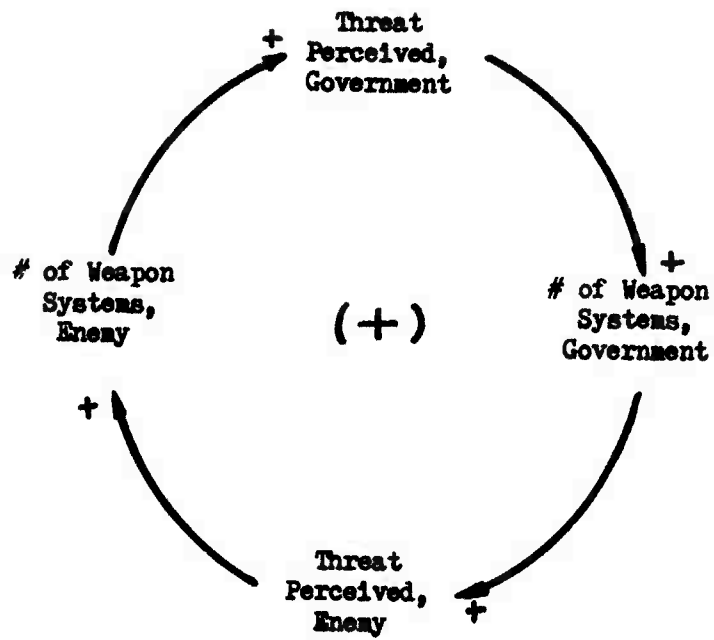

Figure 4
Positive Causal Links



[6.16]

Figure 5
Positive Causal Loop

decrease. The relative magnitude of the increases or decreases is not reflected, only the trends. As shown in Figure 4, links representing those positive relationships are identified graphically by a plus (+) at the arrowhead end, and are called positive links.

When all positive links form a loop, as in Figure 5, the resulting loop reflects an uncontrolled growth or uncontrolled decay type of behavior. An increase in any one of the variables in the loop causes subsequent increases to occur in all other variables in the loop, due to the positive link relationships. These increases eventually cause an increase in the original variable itself. This added increase in the original variable starts the growth process all over, thus resulting in a continuing growth pattern. Similarly, if any of the variables decreases, the result is a downward spiral in the value of all the variables. Loops exhibiting such uncontrolled growth or decay are called positive causal loops, and are identified with a plus sign (+) within parentheses inside the loop, as is shown in Figure 5.

It should be noted that the Figure 5 positive loop is the causal loop equivalent of the Figure 2 flow diagram. Both exhibit continuous growth. The causal loop, however,

reflects only the essence of the arms race example, not the detail. This ability to capture basic system behavior without having to get into the detail of the flow diagrams was the reason causal loop analysis was used as a preliminary step to developing the flow diagram model.

In addition to positive links and loops, there are also negative links and loops involved in the causal loop diagramming. A negative link reflects an inverse causal relationship between the variables. Increases in the tail end variable result in decreases in the arrowhead end, or decreases in the tail end variable result in increases in the arrowhead end variable. Figure 6 shows an example of a negative link. The nature of the negative link is indicated at the arrowhead end by a minus (-) sign. One of the variables used in Figure 6 comes from the positive causal loop shown in Figure 5. The Figure 6 causal link shows that as the number of Weapon Systems increase, the remaining available resources to construct weapon systems decrease.

In Figure 7, the negative link of Figure 6 is combined with two positive links to form a causal loop. This loop's behavior is just the opposite of positive causal

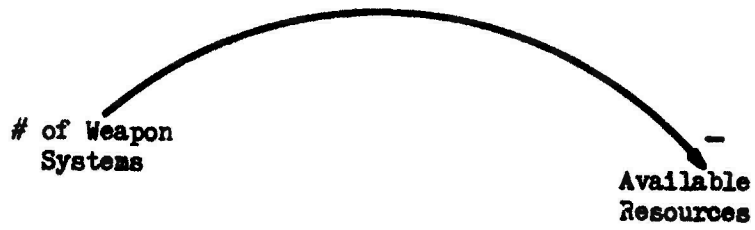

Figure 6

Negative Causal Link

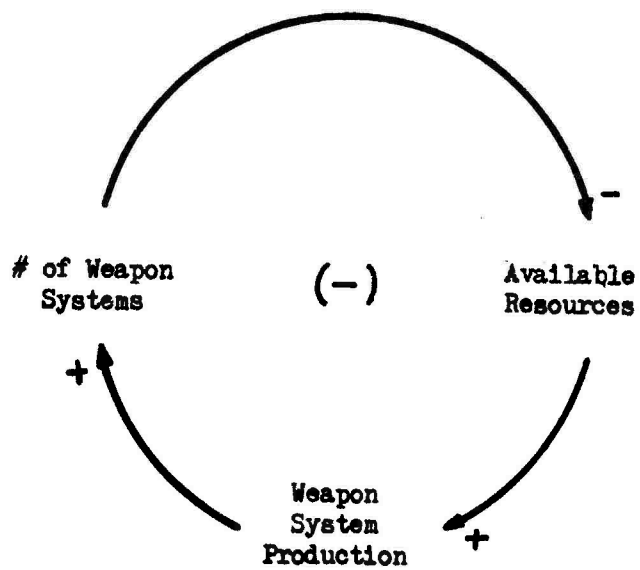

Figure 7

Negative Causal Loop

loop behavior. That is, an increase in any variable eventually results in a decrease in that variable. For example, if there is an increase in Weapon Systems Production, there results an increase in the number of Weapon Systems. The increase in number of Weapon Systems, however, results in a decrease in Available Resources. The decrease in Available Resources results in a decrease in Weapon Systems Production. Therefore, an increase in Weapon Systems Production resulted in a decrease after one circuit of the loop. It can be shown that a decrease would result in an increase after one circuit of the loop.

This type of goal seeking or controlled behavior characterizes negative causal loops. Such loops are identified with a negative sign (-) in parentheses as shown in Figure 7. Negative causal loops result from an odd number of negative links in a loop. When there are no negative links, or when an even number of negative links exist, a positive causal loop results. In effect, a negative link cancels out the effect of another negative link when both are present in a loop.

The basic procedures involved in causal loop diagramming are:

1. To develop causal links based on known/perceived relationships.
2. To use the links to form causal loops.
3. To join loops together into a system.
4. To determine the natures of the resulting causal loops.

The result of these procedures is a rough system dynamics model; the internal validity of which is dependent only on the proper assessment of the relationships reflected by the links.

Figure 8 is an example of a completed causal loop analysis that was performed using the above procedures. The system modeled is the arms race system that has been used throughout this chapter. In the model, the availabilities of resources are reflected as the controlling factors. The example uses the previously developed positive and negative causal loops, and combines them to form the model. Delays inherent in the system are also identified. The format of Figure 8 is representative of the causal loops developed for this research effort.

It can be seen that causal loop diagramming/analysis is useful in system dynamics modeling as an intermediate operationalizing step. Causal loops capture

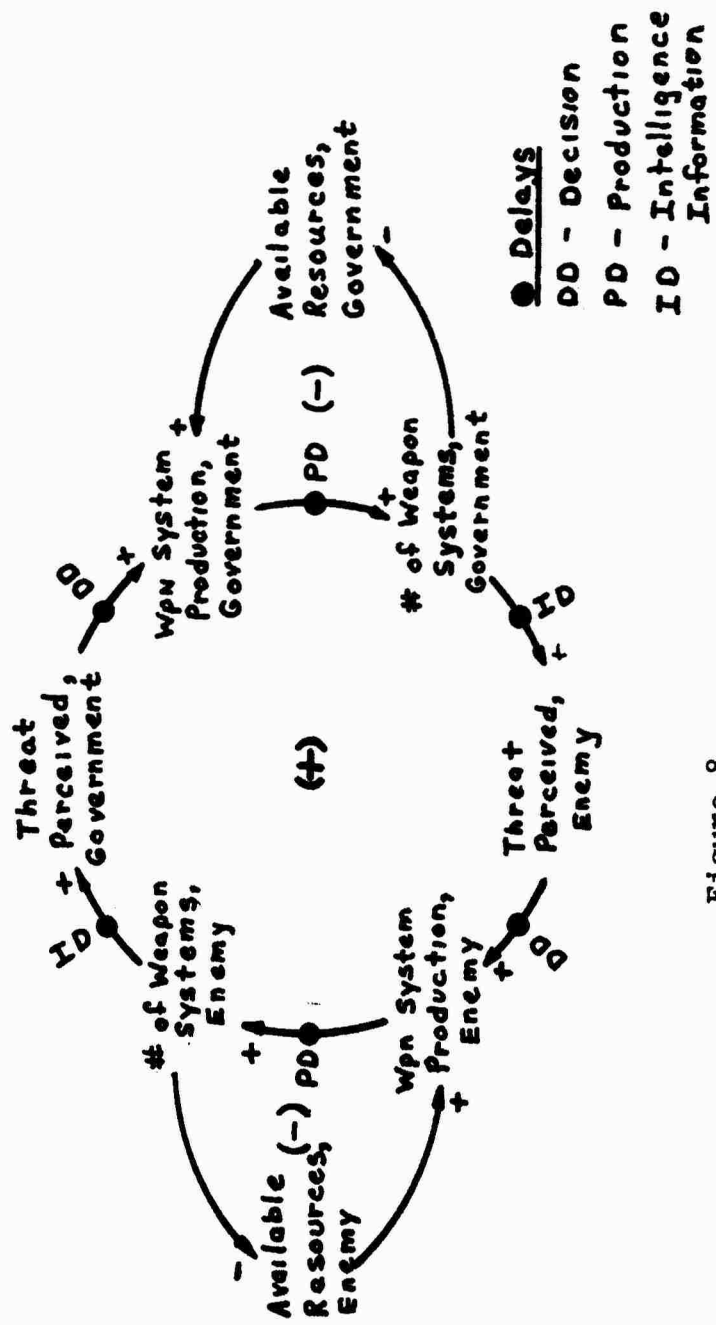

Figure 8

Causal Loop Model

the basic behavior of the modeled system without the detail of the flow diagrams. As a result, the causal loop construction is simpler, and permits easier recognition of the interacting relationships between system elements.

Summary of modeling effort. As described above, the modeling effort of this research used the system dynamics modeling technique in a six-step process. The process involved the use of causal loop diagramming/analysis to translate gathered data into causal loops. The causal loops were translated into system dynamics flow diagrams; the flow diagrams were then refined into their final form.

Model presentation. The conceptual model developed using the above described methods and techniques is presented in Chapters 3 and 4. Chapter 3 presents and describes the system sectors and causal loop diagram used to develop the system flow diagrams. Chapter 4 presents and describes the system dynamics flow diagrams.

The two chapter format was selected because it closely reflects the significant phases of the research, and permits better understanding of the final model. As

mentioned earlier, the causal loops are presented in the same format as the ones in Figure 8, and the flow diagrams use the same symbols presented in Figures 2 and 3. Some additional symbols are used in the flow diagrams and are defined in Chapter 4.

Chapter 3

SECTOR DESCRIPTION AND CAUSAL LOOP ANALYSIS

Introduction

This chapter presents and describes the system sectors, sector interactions, and the causal loop diagram resulting from analysis of those sectors. Sectors as used in this research, represent the major influences within the system at an aggregated, generic level. In researching the DoD major system acquisition process, a "world view" of the process's sectors was initially taken. That is, the process was looked at from the perspective of how it related to the goals and objectives of the nation as a whole. This viewpoint was adopted to gain a clear understanding of the factors influencing the behavior of the process.

As a result of data analysis, a contextual setting was conceived that formed the framework within which the causal loops and flow diagrams were developed. In essence, the contextual setting provided the frame of reference for the remainder of the research.

Contextual Setting of the Acquisition Process

The major system acquisition process is only one of the major functions that DoD performs in "providing for the common defense [9:26]." It must also plan, support, and operate those acquired systems. However, the DoD is not an entity unto itself; rather, it is an instrument of the U.S. Government, and is used to achieve national goals and objectives through execution of national policies.

National policies, in themselves, are a reflection of the feelings and perceptions of the U.S. populace. Because the U. S. is a democracy, the government is constantly provided feedback on those feelings and perceptions. Through the elections of officials, public demonstrations, and public and private means of communication (i.e., television, radio, newspapers, and letters), government is influenced to adjust existing national policy. The basic goals of the government, however, remain unchanged; only the manner used to achieve those goals is adjusted.

The goals of the U.S. Government are stated in the preamble to the U.S. Constitution, and are used to justify and evaluate the actions of the government. The

national goals as stated in the preamble are:

1. To form a more perfect union.
2. To establish justice.
3. To insure domestic tranquility.
4. To provide for the common defense.
5. To promote the general welfare.
6. To secure the blessings of liberty (9:26).

It is within this framework of governmental goals and national policies that the DoD and its major system acquisition process function. The acquisition process, therefore, is strongly influenced by existing national policies. Such national policies, however, may not be conducive to efficient or effective acquisition of weapon systems.

The imposition of national policy on the acquisition process is evidenced by legislation such as: the Buy American Act, the Small Business Act of 1958, Fair Labor Standards Act of 1938, and the Walsh-Healey Public Contracts Act of 1936 (2:13-21). All these acts, and a multitude of other acts and Executive Orders, regulate the manner in which the government does business. They all reflect the embodiment of one or more of the national goals.

The influence of the national goals differentiates government business practice from private industry business practice. One of the important differences is that the government's goals are essentially idealistic and unmeasurable, while private industry has a practical, measurable goal in the form of profit.

In summary, the DoD major system acquisition process is an activity of the U.S. Government, and as such is influenced by national policies and goals. Since national policies are a reflection of the feelings and perceptions of the U.S. populace, they are subject to change with the times. As a result, the acquisition process is seen as more than just the means for the procurement of defense articles. It is also used to achieve national goals through changing national policy.

System Sectors

This world view of the major system acquisition process resulted in the segregating of the system into six sectors. These sectors were:

1. The populace of the U. S.
2. The Office of the President.
3. The Congress.

4. The Department of Defense (DoD).
5. The Enemy.
6. The Defense Industry.

These sectors represented the major influences in the acquisition process whose interactions play an important role in the overall behavior of major system acquisitions.

Sector interactions. Figure 9 shows the primary generic relationships between these sectors. It depicts the populace as interacting with the President and Congress in a political manner. That is, the populace can be seen to exert political pressure on the President and the Congress to respond to their desires for federal programs. The populace also perceives a certain amount of threat from the enemy sector which it may or may not turn into political pressure. The source of its threat information is generally the news media. Additionally, the populace is influenced economically by the defense industry. Because of its relatively large employment capabilities, the health of the defense industry can affect the economic well-being of the populace.

In Figure 9, the President is shown as interacting politically with Congress as well as with the populace.

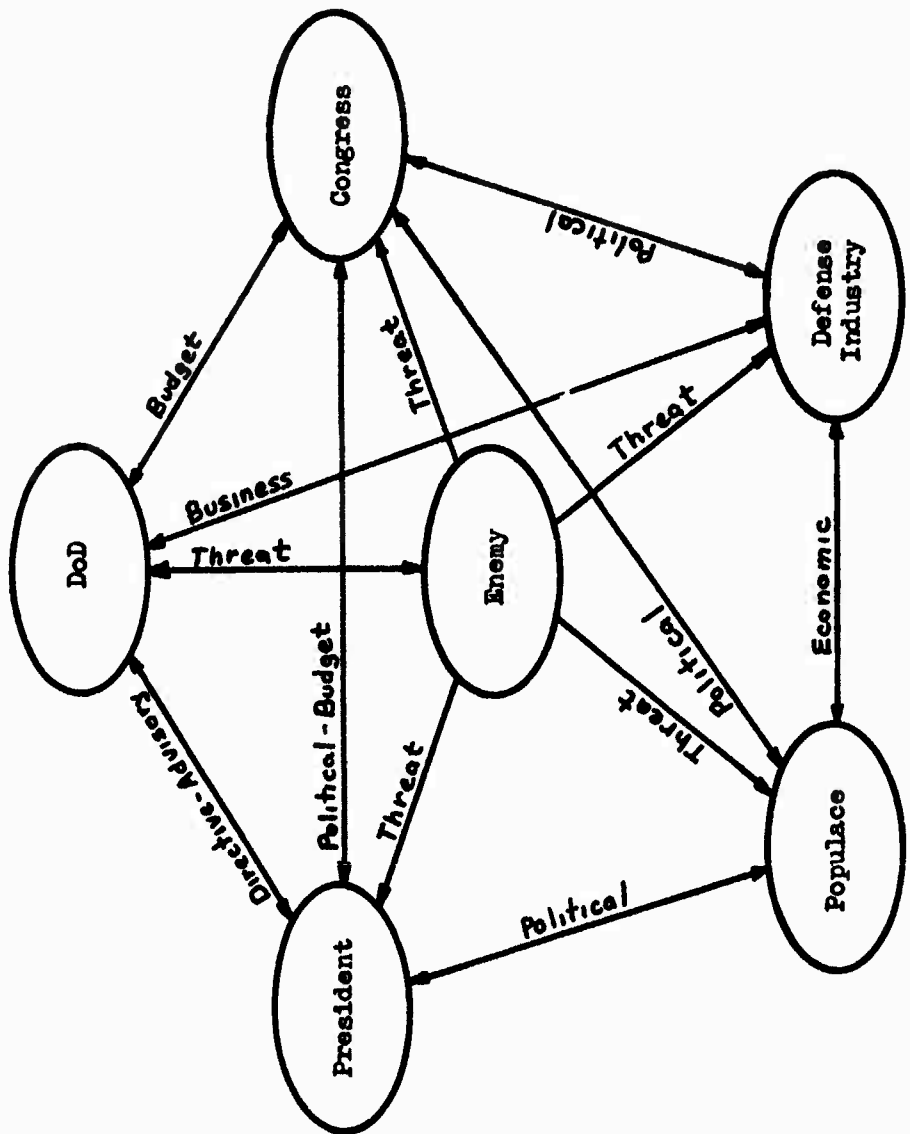

Figure 9
Sector Interaction Diagram

Additionally, the President interacts budgetarily with Congress through submission of the budget. Therefore, a political-budgetary relationship exists between these two branches of government. Both branches use political pressure in an attempt to influence each other. The President is also seen as being influenced by his perception of enemy threat. Finally, the President interacts with the DoD as its Commander-in-Chief, a directive role. The DoD, however, interacts with the President in an advisory capacity.

DoD, in addition to its interaction with the President, is shown as having relationships with Congress, the defense industry, and the enemy sector. The DoD-Congress relationship is seen as primarily a budgetary one. DoD depends on Congressional authorization and appropriation for its funding, and in particular, it is dependent on Congress for funding for its major system acquisitions. Justification for the major system spending is provided by DoD through its testimony to the Congress. In general, this DoD testimony is based on the results of its interaction with the enemy sector. Through its intelligence gathering effort the DoD attempts to assess the enemy sector's threat, while the enemy sector attempts to assess the DoD's threat.

A special business relationship exists between DoD and the defense industry. For the most part, DoD is the only customer shopping in a marketplace of few sellers. Not only is DoD supposed to shop wisely in this market, but it must do its shopping in a manner that supports national policy. The defense industry, on the other hand, is dependent on the DoD for its overall well-being, and as such, is willing to adapt to DoD's unique business situation.

In Figure 9, Congress also is shown perceiving threat from the enemy sector; however, its sources of information may differ from those of DoD. For example, Congress may perceive threat as a result of news media reports instead of intelligence reports. Also, the populace's perception of threat reaches Congress indirectly through political interaction. Congress also politically interacts with the defense industry. Defense industry lobbyists exert political pressure on Congress, while Congress exerts its legislative and budgetary influences on the defense industry.

Finally, the defense industry, in addition to the interactions described above, is also influenced by enemy

threat. However, because of its business relationship with DoD, the defense industry's perception of threat is probably closer to DoD's than any other non-enemy sector.

It was apparent in the development of the sector interactions that perceived threat was an important influence on all non-enemy sectors. Two characteristics of the different perceptions of threat were noted. The first was the different sources of information upon which the perceptions of threat were based, and the second characteristic was the timing of those sources. Congress and the populace were seen as receiving their threat information through relatively delayed public communications, while DoD, the President, and the defense industry received their data through more timely, confidential means. It was also recognized that the basis for the public communications is oft times "leaked" defense information.

The effect of the different timing and different information sources in the perception of threat was seen as a particularly important factor that influenced DoD-Congressional relations. DoD's perception of a specific

threat is not only different, but occurs significantly ahead of the Congressional perception. This appears to be an inherent characteristic of the system.

In summary, the acquisition process was seen as being influenced through the actions of six sectors: the populace, the President, the DoD, the Congress, the defense industry, and the enemy sector. The interactions between these sectors are varied and different with the exception of the threat interaction. The threat interaction of non-enemy sectors is seen as having timing and information source differences. These sectors, and the sector interactions provided the basis for the causal loop analysis.

Causal Loop Analysis

Since the six sectors described above are a world view of the acquisition process, the task of developing and analyzing causal links and loops for all elements in each of these sectors was not feasible in the time allotted. Therefore, the sectors for analysis were segregated into those that were further analyzed and represented the system, and those that were to remain aggregated, and represented the environment. The

segregation of the sectors was made on the basis of control; that is, those sectors that exerted significant control in some form relative to the workings of the acquisition process were selected as being in the system.

Based on the above paradigm, the sectors of DoD, President, and Congress were analyzed further. The sectors of enemy, populace, and defense industry were left in an aggregated state and viewed as influencing the system through a few input variables. No attempt was made to analyze the internal generation of those inputs. For example, the enemy sector has a certain level of capability, and intelligence information about this level is an input into the acquisition process system; no attempt was made to examine the inner workings of the enemy sector to see why the capability was at the level it was. Instead, the system's reaction to changes in enemy capability was modeled. Therefore, the level of capability represented an exogenous input into the system.

The remainder of this chapter presents and details the causal loop diagram that was derived from the analysis of the system sectors, and discusses the overall behavioral characteristics of the causal loop.

Casual loop diagram. Figure 10 represents the complete causal loop diagram resulting from the analysis and synthesis of the research data. It depicts the behavioral characteristics of the DoD major system acquisition process. It shows the process as functioning within the U.S. government, and reacting to exogenous inputs from the populace, the defense industry, and the enemy sectors. The diagram also reflects a conscious reduction in the level of abstraction from previous discussions. Specifically, the causal loop diagram reflects the acquisition of defense articles for a specified mission area (MA), rather than all defense articles in general.

The authors found that this reduction in abstraction level permitted a much clearer depiction of the behavior of the system, and was consistent with current regulatory guidance. That is, DoD Directive 5000.1 (15), as a result of OMB Circular A-109 (3), reflected the emphasis on mission areas. A mission area, as defined in DoD 5000.1, is: "A segment of the defense mission as established by the Secretary of Defense [15:2]." An example of such a mission area is the strategic forces mission area. Each of the services

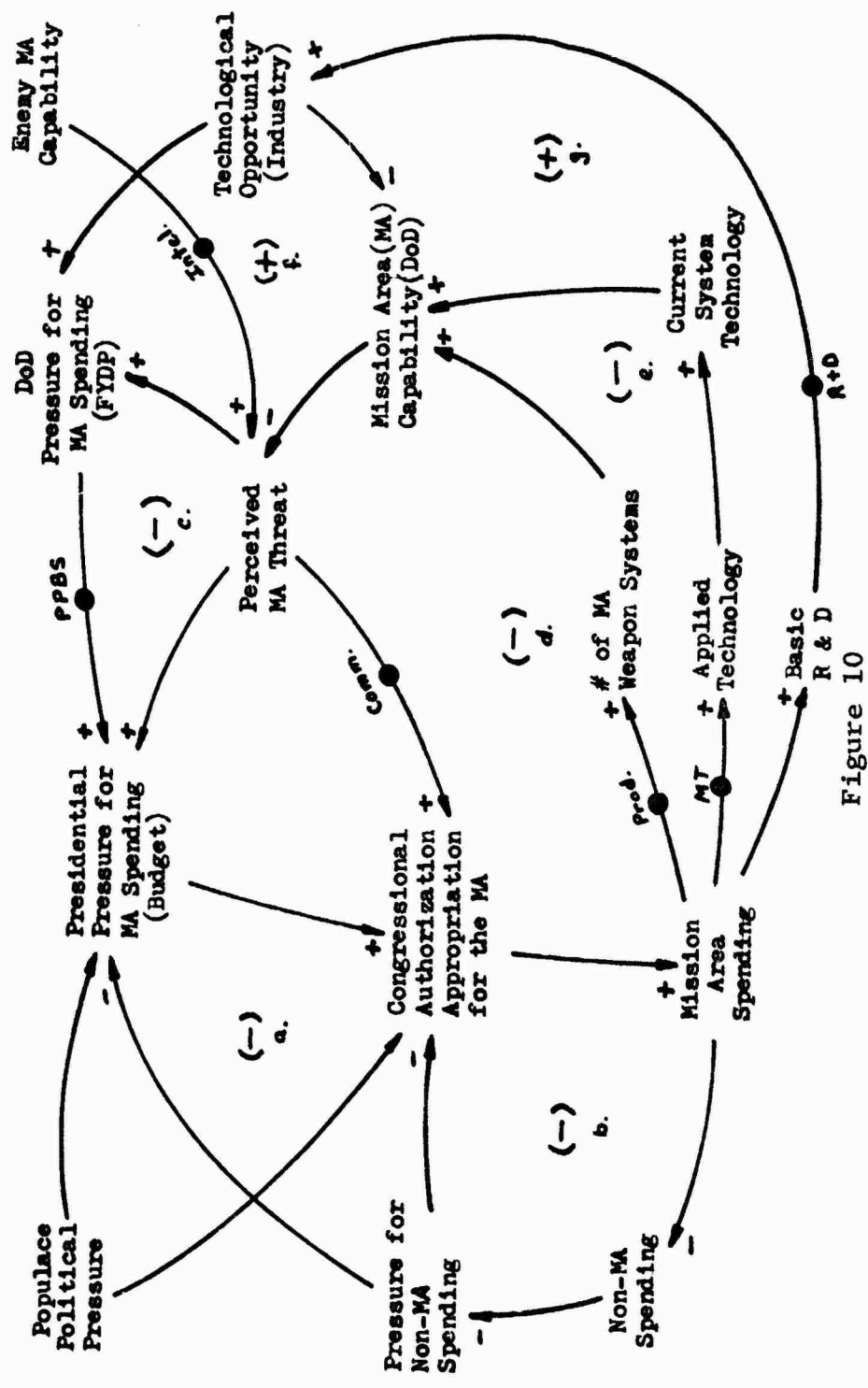

Figure 10

System Causal Loop Diagram

may have a distinct role in the accomplishment of mission area objectives; however, for the purposes of this research, actions of the services were not explored, rather, DoD was viewed in the aggregate as the agency procuring systems to meet mission area objectives.

Since threat and capability were seen to be key factors in the DoD acquisition process, the description of Figure 10 is started at Perceived Mission Area (MA) Threat.

As shown in Figure 11,* Perceived MA Threat is linked to Enemy MA Capability, and Mission Area Capability as perceived by DoD. The Enemy MA Capability causal link is shown as positive while the Mission Area Capability is shown as a negative link. These two links reflect that Perceived MA Threat is a function of the intelligence data received by DoD on the level of capability of an enemy in specific mission area, and the level of capability of DoD also in that mission area. As Enemy MA Capability increases, so does Perceived MA Threat, and conversely,

*Note links under discussion are emphasized in the diagrams.

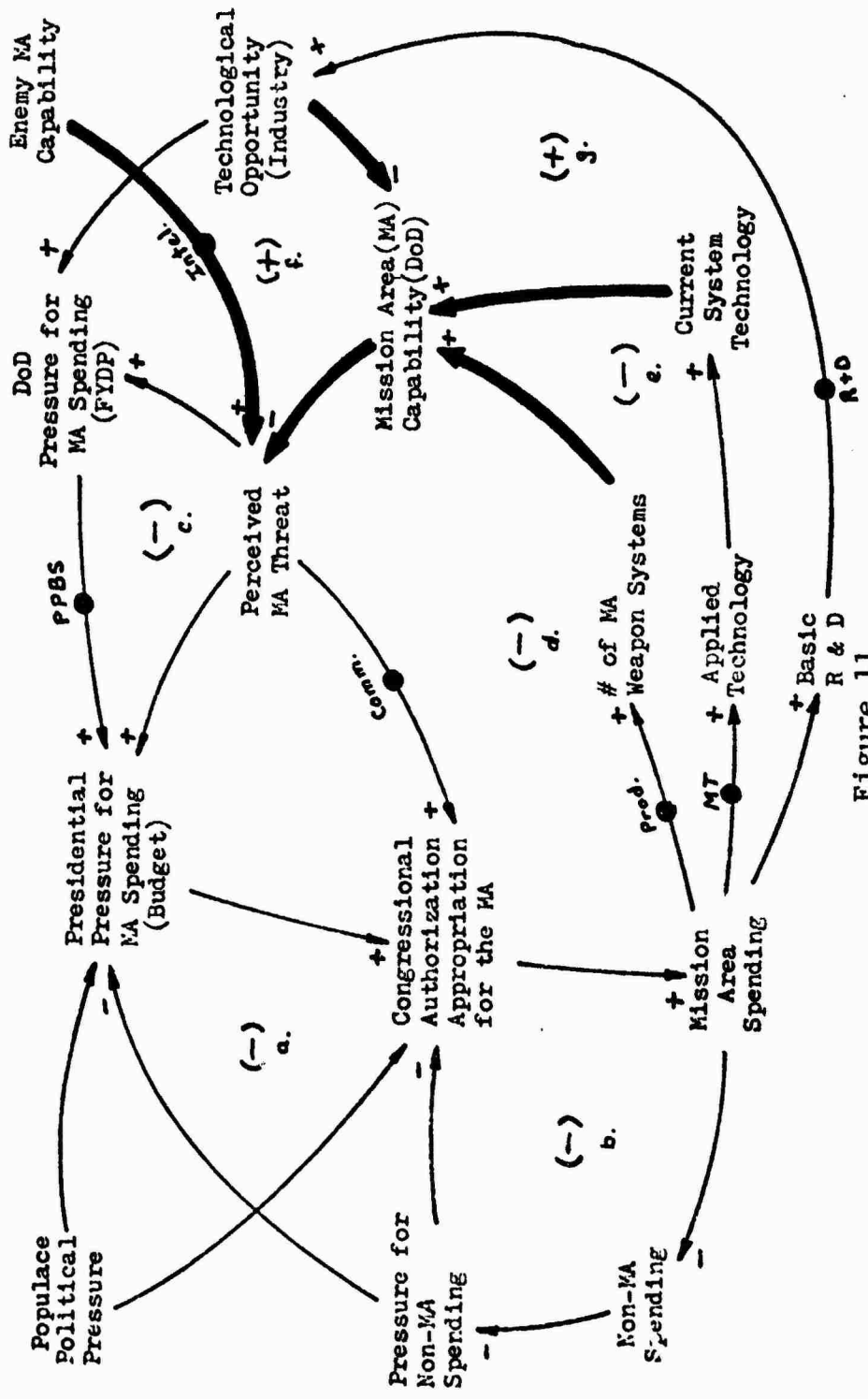

Figure 11
Threat Perception-Threat Reduction Causal Links

as Mission Area Capability increases, the Perceived MA Threat decreases. In effect, the Mission Area Capability is subtracted from the Enemy MA Capability, and the resultant difference is perceived as the degree of MA threat.

An example of this type of threat perception can be seen in the manner that defense strengths are compared in articles in such military oriented magazines as Air Force (12), or in non-military oriented magazines, such as Time (13). Recent articles in both publications compared strengths and discussed threat based on levels of capability. The levels of capability discussions generally centered on the number of weapon systems and the technological characteristics of those systems. Subsequently, the primary basis for the assessment of threat was on these two items. As a result, Mission Area Capability was seen as a function of technology and the number of weapon systems. This perception is reflected by the three causal links feeding into Mission Area Capability: Current System Technology, number of MA Weapon Systems, and Technological Opportunity.

Current System Technology and number of MA Weapon Systems are shown as positive links, and essentially

reflect the relationships discussed above. Current System Technology represents an average level of technology of the systems in the current inventory. As Current System Technology increases, Mission Area Capability was seen to increase also. Similarly, the overall Mission Area Capability was seen to increase as the number of weapon systems increased.

Technological Opportunity, the third link shown feeding into Mission Area Capability, reflects future, and supposedly feasible, levels of technology. It depicts the aggregated input of the defense industry to DoD relative to its potential to increase the technology of weapon systems. Examples of this type of input are: advertising in military oriented publications, formal and informal discussions, suggestions for technological improvement, engineering change proposals, and the brochureship of the defense industry sales organizations.

The Technological Opportunity link is shown as a negative causal link. It was observed that the perception of a possibly higher level of technology in effect detracted from the current technology's influence

on overall capability. This reduction in overall capability, due to an apparent disparity in current technology versus some implied advanced technology, was seen as a normal result of human nature. Two psychological phenomena were perceived as occurring. The first phenomenon is the feeling that something is not as good, when one sees something that appears better. The second phenomenon is that DoD, as the agency responsible for national defense, assumes that if our industry is capable of producing a certain level of technology, so must the enemy, and to assume otherwise courts possible disaster (19:10). The DoD, therefore, perceives a certain decrease in Mission Area Capability when faced with increases in Technological Opportunity. This characteristic of DoD was substantiated both in the Commission Government Procurement report (19:10) and throughout Arming America (5).

Looking again at Perceived MA Threat, Figure 12 shows that as this threat increases, so does DoD Pressure for MA Spending. This pressure is reflected in an increased emphasis in the documents of the Joint Strategic Planning System and the DoD Planning, Programming and Budgeting System. That is, increased mission area threat

is reflected in the attention given that mission area in documents such as: the Joint Intelligence Estimate for Planning (JIEP), the Joint Long-Range Strategic Objectives Plan (JSOP), and/or the Five-Year Defense Program (FYDP).

The pressure for MA Spending is translated into budgetary pressure through the submission of the Presidential Budget. This budget submission is the culmination of almost 2 years of planning, programming, and budgeting interaction between the DoD and the President, and readjustments to the FYDP are periodically made as a result of this interaction (17:19). The final result of this process, however, is the Budget itself. It reflects the Presidential final word on his pressure for specific programs. Additionally, DoD's mission area budget requests can be seen to be the basis for the Presidential budget requests. As a result, Presidential pressure for MA Spending is shown as increasing as the DoD Pressure for MA Spending is increased.

There are other pressures applied to the President relative to a mission area's budget. In Figure 12 these are shown as Perceived MA Threat, Populace Political

Pressure, and Pressure for Non-MA Spending. Perceived MA Threat is shown as having a positive influence on the Presidential Budget. As was observed in the development of the sector interactions, threat is perceived by all branches of government, and these perceptions may differ. The causal link shown represents the concept that the President is influenced by his own perception of threat. However, it was noted that the sources of his defense data are primarily DoD and CIA. Therefore, the President is generally influenced to increase pressure for spending on a mission area as a result of his perception of an increased threat.

Populace Political Pressure is shown as an input into the Presidential Pressure for MA Spending; however, no positive or negative relationship is indicated. This link represents the feelings and perceptions of the populace about a mission area's expenditures. As such, it was seen to have both positive and negative impacts, and these impacts were dependent on socio-economic factors. For example, the typical anti-military outlook after a war appears to impact on the populace's view toward military spending. In general, this could be seen as a negative

input. On the other hand, the public's concern when there is an increased perception of threat, such as may be occurring now in the U.S., may result in a positive input.

The character of Populace Political Pressure as input into Presidential Pressure for MA Spending, therefore, was observed as being dependent on the time period and socio-economic factors. In effect, this link represents an exogenous input to the President from the populace.

The last link shown going into Presidential Pressure for MA Spending is Pressure for Non-MA Spending, and is a negative causal link. In essence, this link was seen as representing the generalized pressure to reduce spending in a particular mission area. This pressure comes from Congress, DoD, or the populace. How this pressure is caused is addressed in the discussion of the Congressional Authorization Appropriation for the MA, and Mission Area Spending links.

Congressional Authorization Appropriation for MA is reflected in the diagram as increasing as Presidential Pressure for MA Spending is increased. Congress was observed as reacting in this positive manner since it

acts on a budget provided by the President. In general, the spending trends requested in that Budget are approved by Congress. It was seen that the testimony of DoD, the lobbying of the defense industry, and the pressures applied by the White House all result in increased expenditures in a mission area.

The causal loop diagram also shows Perceived MA Threat interacting with Congress in a positive manner. Like the President, Congress is influenced by its perception of threat. This perception was observed as resulting from news media articles, DoD testimony, and populace pressure. DoD was seen as the primary source of threat information, yet it was perceived that Congress has been suspicious of the veracity of such information.

The reason for this suspicion appears to be that DoD produces the very threat information that is used to justify its own programs. As such, there is the distinct possibility of a self-interest slanting of the information. The GAO report (19), the Commission on Government Procurement Report (14), and Arming America (5) all reflected throughout their pages this effect of advocacy by DoD in the "selling" of its defense programs to

Congress. This apparent distrust of DoD threat information was seen to delay Congressional realization of a threat. Additionally, Congress, being a political body, is influenced heavily by the populace and its perception of threat. This influence is depicted in the diagram by the link from Populace Political Pressure. As in the Presidential Pressure for MA Spending discussion above, the Populace Political Pressure was seen as exerting both positive and negative influences on Congress.

Congressional Authorization Appropriation for the MA is affected by Pressure for Non-MA Spending in a negative way. This was observed as a natural consequence of increased mission area authorization and appropriation (A & A) legislation passed by Congress. As shown in Figure 13, increased A & A for a specific mission area results in increased Mission Area Spending. Given limited resources, an increase in spending in one area decreases the spending in all the other areas to some extent. For example, it can be seen that if spending in the strategic forces mission area is increased, then spending for general purpose forces could decrease to some extent. Also, such spending could conceivably

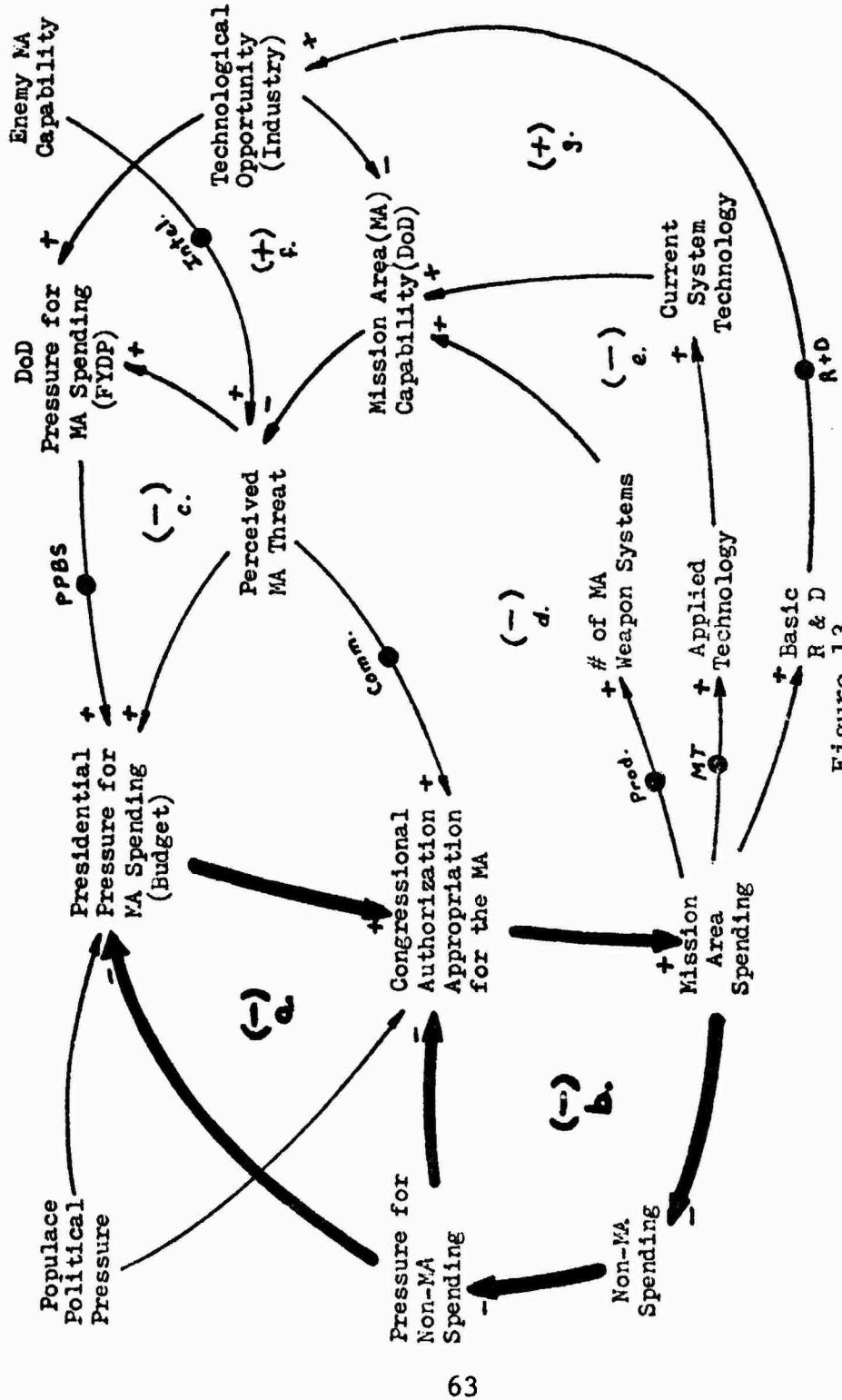

Figure 13
Resource Allocation Causal Links and Loops

decrease spending in non-defense areas such as VISTA programs, foreign aid, or housing subsidies. This aggregated effect of increased mission area spending is shown by the negative causal link between Mission Area Spending and Non-MA Spending.

Decreases in Non-MA Spending were seen as increasing the Pressure for Non-MA Spending. In effect once Congress has made its authorizations and appropriations, those interests receiving less than their desired share of the budget (losers) were seen to mount a campaign to increase their share of the next year's Budget. This pressure to increase non-mission area spending was visualized as coming from these "losers" within Congress itself, from these "losers" within DoD, and from the "losing" portions of the populace. The total effect of these factions is the generalized pressure to reduce that which has been increased. This pressure was observed as being applied to both Congress and the President, and as such, is reflected in the causal loop diagram by the negative causal links from Pressure for Non-MA Spending to Presidential Pressure for MA Spending, and Congressional Authorization Appropriation for the MA. This series of

links, in essence, captures the controlling effect of limited resources on acquisition spending in general, and mission area spending in particular.

Also, two negative causal loops are formed by this series of links. These loops are: Presidential Pressure for MA Spending--Congressional Authorization Appropriation for the MA--Mission Area Spending--Non-MA Spending--Pressure for Non-MA Spending--Presidential Pressure for MA Spending (Causal Loop "a"), and Congressional Authorization Appropriation for the MA--Mission Area Spending--Non-MA Spending--Congressional Authorization Appropriation for the MA (Causal Loop "b"). The total effect of these causal loops on the system behavior are discussed, along with the other resulting causal loops, in the Causal Loop System Behavior section that follows this section.

Increased Mission Area Spending was seen as increasing three facets of the acquisition process (See Figure 14): number of Mission Area Weapon Systems, Applied Technology, and Basic Research and Development (R & D). It was observed that as a natural consequence of increased spending in a mission area, the number of

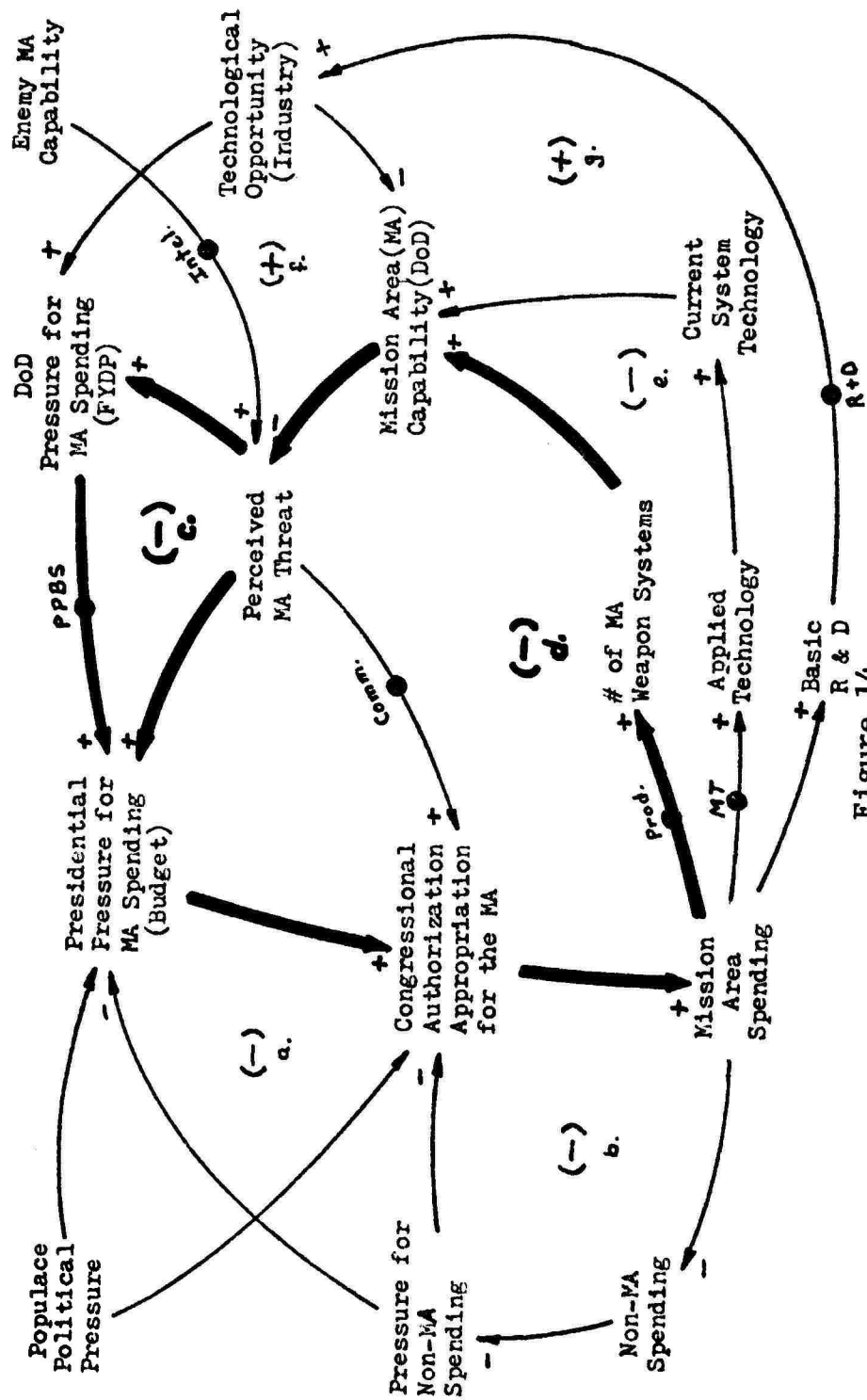

Figure 14

Weapons Production-Threat Reduction Causal Loops

systems in that area also increased. For example, the emphasis in recent years on general purpose forces has resulted in the development of systems such as: A-10, F-15, F-16, F-18, and the M-1 Tank. As can be seen in the figure, this positive link between Mission Area Spending and number of MA Weapon Systems forms two negative causal loops. They are: number of MA Weapon Systems--Mission Area Capability--Perceived MA Threat--DoD Pressure for MA Spending--Presidential Pressure for MA Spending--Congressional Authorization Appropriation for the MA--Mission Area Spending--number of MA Weapon Systems (Causal Loop "c"), and number of MA Weapon Systems--Mission Area Capability--Perceived MA Threat--Presidential Pressure for MA Spending--Congressional Authorization Appropriation for the MA--Mission Area Spending--number of MA Weapon Systems (Causal Loop "d"). The second loop is essentially the same as the first with the exception of DoD Pressure for MA Spending being bypassed. Both causal loops contain the same negative link, Mission Area Capability--Perceived MA Threat. In essence, these loops indicate that reduced threat through increased capability is the primary link that prevents uncontrolled growth.

Returning to Mission Area Spending, Applied Technology was seen to also increase with increases in Mission Area Spending (See Figure 15). In general, as newer systems are manufactured, and old systems modified, monies spent can be seen to improve the overall manufacturing technology of the defense industry. The ability to actually produce a system of increased technology was observed to be a result of the lessons learned in the production or modification of the systems themselves. This perception is reflected by the positive causal link between Mission Area Spending and Applied Technology.

With increases in Applied Technology, it can be seen that the Current System Technology also increases. As the new technology manifests itself in the systems produced or modified, the level of technology of the mission area weapon system inventory was observed to rise. That is, in having weapon systems with a more advanced technology replacing older systems, DoD perceives an overall increase in the technological capability of its weapons inventory. This increased technological capability, however, is evaluated by looking at the

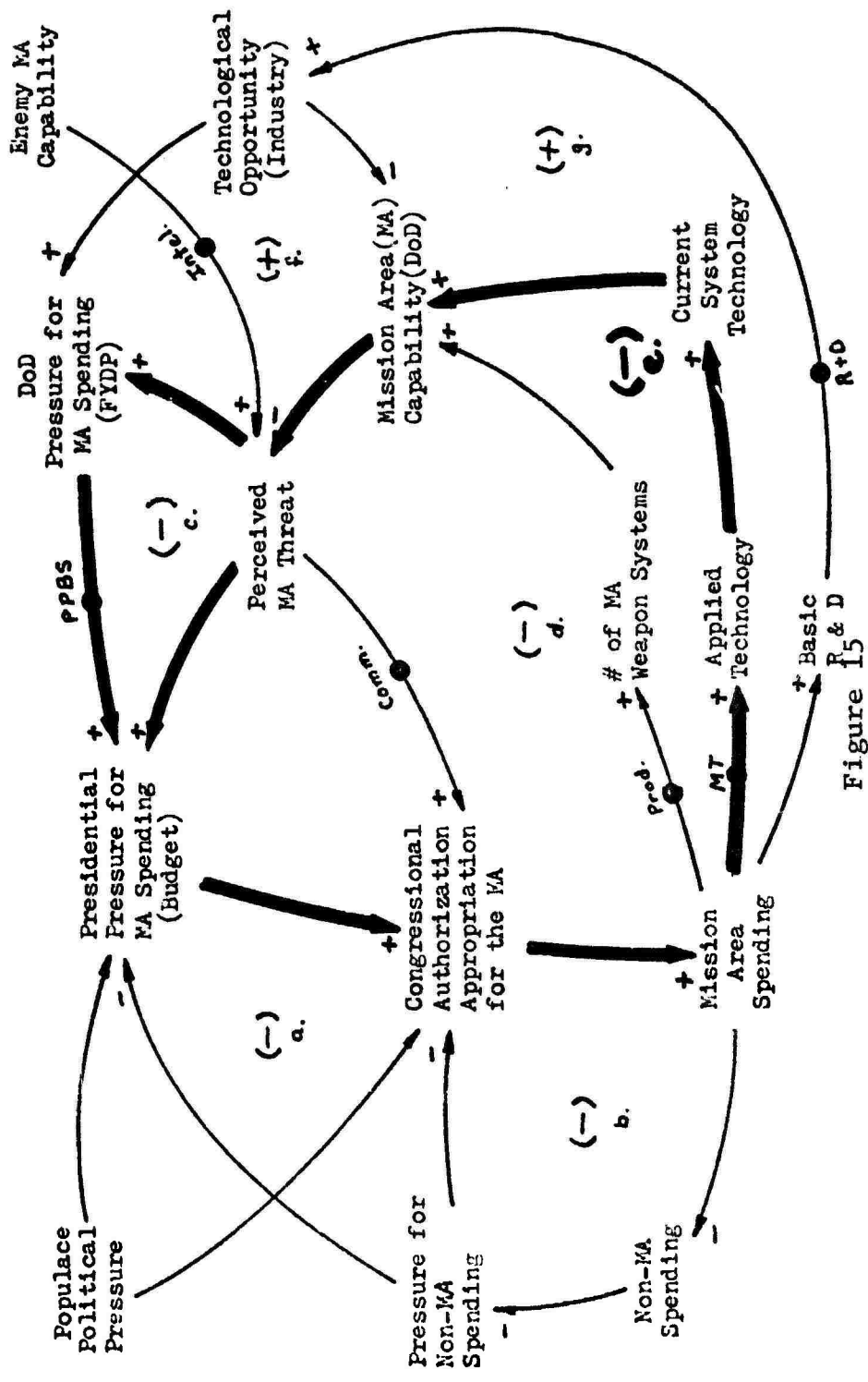

Figure 15

Technology-Threat Reduction Causal Loops

technological characteristics of the older systems. As a result, DoD was seen as trying to accomplish mission area objectives in the same way as with the older systems; rather than trying to accomplish them in a different or innovative manner.

This behavior to improve what is, rather than seek out something new was reflected in Commission on Government Procurement report (19:37-45), and Arming America (5:100-103). The defense industry also was reported to be attuned to this outlook by the DoD, and keyed its efforts to providing what DoD was looking for, not what it "needed" (5:101). An example of this behavior is the current controversy over the Navy's desire to build more aircraft carriers, particularly nuclear powered aircraft carriers. In essence this controversy stems from the question of the necessity to have better and more capable aircraft carriers. The arguments for the carriers are based on the ability of the aircraft carrier to project a tremendous amount of force at sea, while the arguments against are based on the carrier's vulnerability to attack (13:23). The question of how to project that same power differently appears not to be addressed.

Based on the discussion of the Applied Technology--Current System Technology link, it can be seen that the manner in which Applied Technology causes an increase in DoD's perception of the level of Current System Technology can have a decided effect on the perceived Mission Area Capability. That is, the existing technology of the defense industry in a particular field may make it possible to produce weapon systems of a different character such that these systems could also meet the mission area objectives. Yet DoD, and perhaps the industry itself, may not recognize the worth of the technology, since it is looking for improvements in the more traditional system parameters.

The Applied Technology--Current System Technology link also forms two negative causal loops that are exactly the same as Causal Loops "c" and "d" except that the Mission Area Spending--Applied Technology--Current Systems Technology--Mission Area Capability series of causal links replaces the Mission Area Spending--number of MA Weapon Systems--Mission Area Capability series (Causal Loop "e"). Again, reduction in threat through increased capability is the factor controlling the loop's growth.

The last series of links to be discussed is the Mission Area Spending--Basic R & D--Technological Opportunity--DoD Pressure for MA Spending series (See Figure 16). Here an increase in Mission Area Spending was seen to increase the efforts of Basic Research and Development (R & D). Such increased R & D efforts are the sum result of R & D efforts in production and modification, and in undirected research. The Mission Area Spending--Basic R & D positive causal link was included to suggest that regardless of the area of expenditure (production, modification or independent R & D), some technological breakthroughs result because of the research that must be conducted to accomplish the task.

The increase in Basic R & D was seen to result in greater Technological Opportunity being perceived by the defense industry. Basic R & D opens technological doors and presents the engineers of the defense industry with new challenges. Prior technological successes of the industry increase the optimism of the industry that it can solve the unsolved. This optimism, combined with the profit motive of business, is seen to be a powerful force in the acquisition process.

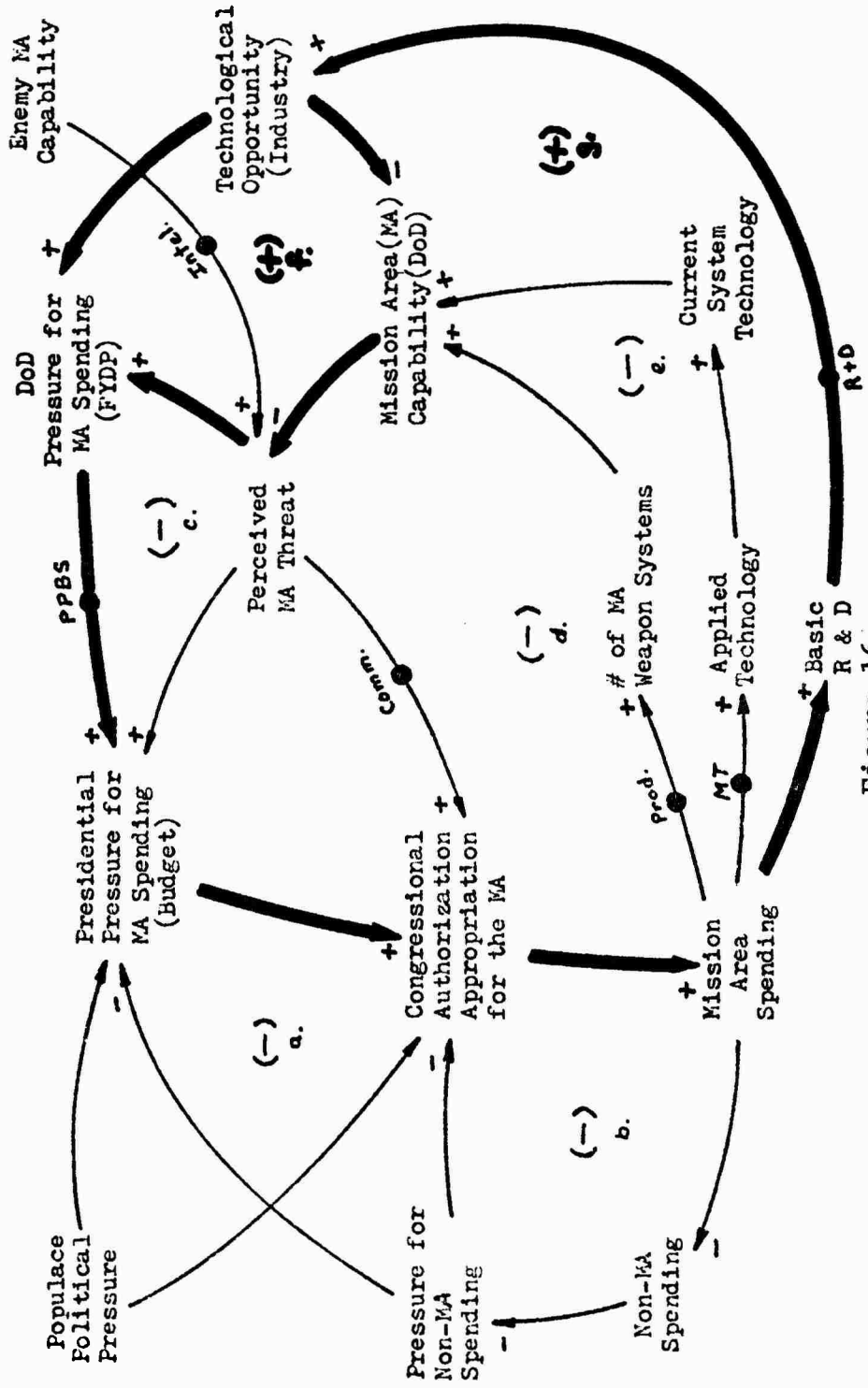

Figure 16

Technological Opportunity Growth Causal Loops

The final link in this series of links reflects that force. The Technological Opportunity--DoD Pressure for MA Spending causal link represents the most controversial facet of the DoD major system acquisition process. The recurring theme in the reports and studies reviewed was the criticism that DoD bought new technology for the sake of having that technology alone. Frederic M. Scherer in the preface to The Weapons Acquisition Process: Economic Incentives, a 1964 publication, observed:

Much of the initial impetus for new weapons development comes, I think, from the fascination of scientists, engineers, and military planners with the technical challenges posed by new weapons concepts; from the urge to triumph over nature in solving a difficult technical problem; and from the desire to be recognized by one's peers for achieving a successful solution [10:x].

More recently, the Commission on Government Procurement stated in their 1972 report that the services define their needs and goals in terms of the kinds of hardware desired and not the mission to be performed (14:10), and "although new technological opportunities cannot be ignored, too often the focus has been on the system product and not on its purpose [4:10]." Lastly, the GAO reflected in their report that:

The "idea" for a new capability can come from a variety of sources. Needs can be identified through the recognition of a deficiency as a result of threat analysis and/or capability planning. In other cases, new technology will emerge in either government or industry and a system or program will be built around it [19:10].

The Technological Opportunity--DoD Pressure for MA Spending link also closes one of the two major positive causal loops of the diagram. This first loop is: DoD Pressure for MA Spending--Presidential Pressure for MA Spending--Congressional Authorization Appropriation for the MA--Mission Area Spending--Basic R & D--Technological Opportunity--DoD Pressure for MA Spending (Causal Loop "f"). It can be seen from this causal loop that, regardless of the threat, there exists growing pressure to spend on a mission area as a result of past expenditures that, in turn, increase technological opportunities.

The second major positive causal loop also has the same effect on Mission Area Spending. This loop is: Technological Opportunity--Mission Area Capability--Perceived MA Threat--DoD Pressure for MA Spending--Presidential Pressure for MA Spending--Congressional Authorization Appropriation for the MA--Mission Area Spending--Basic R & D--Technological Opportunity

(Causal Loop "g"). In this loop there are two negative links: Technological Opportunity--Mission Area Capability, and Mission Area Capability--Perceived MA Threat. The first of these links in effect negates the control exerted by the reduction in threat through increased capability. It can be seen from the two positive causal loops that Technological Opportunity is a factor in both, and as such reflects the influence it may have on the entire system's behavior.

Causal Loop System Behavior

The behavior of the causal loop model of the DoD major system acquisition process is basically the result of the cumulative effects of all the causal loops. As shown in the causal loop diagram, there are five major negative causal loops and two major positive loops. In general, the negative loops represent two control mechanisms in the acquisition process, while the positive loops represent the growth mechanism.

The first of the control mechanisms is the resource allocation control mechanism. Negative Causal Loops "a" and "b" (Figure 13) represent the effect of limited resources and competition resulting from the

allocation of those limited resources. Spending pressures from the populace, Congress, and DoD can be seen as resulting from this basic "economic" behavior of the system's participants.

The second control mechanism is the reduction of threat. Causal Loops "c", "d", and "e" (Figures 14 and 15) represent this mechanism. The key element of this mechanism is the negative link between Mission Area Capability and Perceived MA Threat. This link is common to all the loops in the mechanism. It was observed that this link represents the national, goal-seeking basis for the acquisition process. The goal of the acquisition process, like the whole of the U.S. Government, is the reduction of threat. When a mission area threat has been reduced to a level that is in consonance with national policy, then spending in that area is no longer increased. However, there are two key points to be observed about the threat mechanism that are seen to impact on its ability to control growth. The first of these points is in the area of enemy capability perception.

DoD's perception of the true capability of an enemy is strongly influenced by the uncertainty of the

intelligence gathering effort. In general, this uncertainty can be seen to cause amplification of what data is received so as to insure that no surprises result. That is, DoD was perceived to take the worst case condition outlook on enemy capability. As can be seen from the causal loop diagram, Enemy MA Capability is a driver in Perceived MA Threat. Sudden increases in this input reverberates throughout the system.

The second key point lies in DoD's assessment of its own capabilities. As discussed in the previous section, DoD makes its capability assessment based primarily on the number of systems and some measure of their technological capability. The level of technological capability is "spoiled" somewhat by the perception that something better is available. Again, DoD was perceived to adjust its capability perception. This time, however, it is its own capability that is being assessed, and the effect is to degrade the capability level.

The total result of the above described adjustments in the perceptions of capability was seen as an amplification of the perceived threat, and this amplification was primarily the result of a single agency,

DoD. Therefore, the control reflected in Causal Loops "c", "d", and "e" appears to be dependent on the control DoD exercises internally on the effects of amplification in determining enemy capability levels, and on its control of technological opportunity effects.

Control of the technological opportunity effect is, in essence, the resistance of the negative loops to the positive causal loops that form the growth mechanism. As discussed in the previous section, Causal Loops "f" and "g" represent the continuing pressure to spend in a mission area without regard to perceived threat. The special business situation that exists between the DoD and the defense industry, and national policy were seen to be factors in the existence of this mechanism.

The DoD, in executing national policy, was perceived as having to retain a stable, reliable defense industrial base with sufficient excess capacity to meet possible war-time surges. The defense industry, on the other hand, was observed as an industry that must stimulate continued business in order to pay for that excess capacity desired by the DoD, and to continue to exist. Capacity in this respect refers to trained, experienced personnel,

as well as production facilities and equipment. It was also observed that implicit in the relationship between DoD and the defense industry was the national policy of sustained technological superiority. Since World War II and the detonation of the A-Bomb, the U.S. populace and the government have placed much value on technological superiority. The "space race" reaction to the launch of Sputnik I in 1957 was an example of the influence of this implicit national policy. Therefore, it appeared that the growth mechanism of the major system acquisition process was inherent to the system because of the nature of the DoD-defense industry relationship and existing national policies.

From the above discussions on the mechanisms at work in the acquisition process, it can be seen that the acquisition process is a result of the complex interaction of resource allocation, threat reduction, and growth mechanisms. In addition to the interactions of these mechanisms, the delays inherent in the system were seen as important influences on its behavior. In the causal loop diagram six delays are shown (See Figure 17). These delays were perceived to be the most significant,

and are as follows: Intelligence delay (Intel.); Planning, Programming, and Budgeting System delay (PPBS); Communication delay (Comm.); Production delay (Prod.); Manufacturing Technology delay (MT); and Research and Development delay (R & D).

The intelligence delay was essentially perceived as the same type of delay as was discussed in the arms race system example in Chapter 2. It represents the delay in receiving sufficient intelligence data to make a capability level determination. It was surmised that this delay may take several years for some mission areas; however, no data was reviewed that supported or denied this supposition. Once intelligence data is turned into a level of enemy capability, and then subsequently into threat, the delay imposed by the Planning, Programming, and Budgeting system (PPBS), and the communication delay to Congress affects the translation of threat into funding.

In Figure 17, the PPBS delay is shown between DoD Pressure for MA Spending and Presidential Pressure for MA Spending. This delay was actually seen to exist between the Perceived MA Threat and Mission Area Spending and was so placed on the diagram for clarity. This delay

represents the time necessary to achieve an increase in a mission area's funding. It includes not only the PPBS cycle, but also the Congressional budget approval process. The PPBS cycle itself is a minimum of 20 months long, starting with the Joint Strategic Objectives Plan (JSOP) and ending with the submission of the Presidential Budget (17:19). The Congressional approval process takes an additional 8 months to complete (17:3). Therefore, in general, a minimum of 28 months is necessary to translate an increase in threat to an increase in mission area funding. A complication exists due to the Communication delay between Perceived MA Threat and Congressional Authorization Appropriation for the MA.

The Communication delay represents the delay in Congress becoming aware that a threat does exist. This delay includes the delay for the populace to perceive an increase in threat and exert pressure on Congress to spend more in that area. The magnitude of this delay was not discerned from the research data, but it was surmised that it would be affected by socio-economic conditions. That is, threat pressure must overcome such factors as unemployment, inflation, and anti-war sentiment. Therefore, the magnitude of the threat may have to

increase to a higher level for Congressional recognition, and such higher magnitude was seen as taking more time.

Even after the funding has been increased (and this funding must be authorized/appropriated yearly), the delay between increased funding and increased number of weapon systems is considerable. This is the production delay. For purposes of this research, this delay was seen to be the time lag between the time when a new or modified system is funded for directed Research and Development, and the time that system is operational in quantity. This lag may be from 5-10 years (5:21). Therefore, it can be seen that there is a considerable delay between increased threat and an increase in the number of systems to reduce that threat.

The levels of technology of those new systems were also seen as having a delay. This delay is called the Manufacturing Technology delay, and represents the delay involved in turning technological opportunities into technological realities. The difference in the level of technology represented by Technological Opportunity and the level of current technology was seen as impacting on this delay. A large difference meant a long

delay, while a small difference meant a relatively short delay. If the manufacturing technology delay is too long, relative to when the weapon system is desired, then it was perceived that the advanced technology would be discarded or at least reduced in scope, or the production delay would be increased. In either case, the desired increase in capability would be delayed as a result of the delay in increasing the number of systems or the decrease in the level of technology per system. The production and manufacturing technology delays impact on the perceived capability, and interact as well with each other.

The last delay, the Research and Development delay, was seen to be important not from the standpoint of its absolute magnitude, but from its relative magnitude to the production and manufacturing technology delays. It can be seen that if technological breakthroughs are made as a result of Basic Research and Development, and these occur in a time shorter than the production or MT delay, the level of technology represented by Technological Opportunity increases. This increase, in turn, adds to the difference between the technological opportunity level and the current technology level. Both the DoD and

defense industry were perceived as desiring a reduction in this delay. The former because of its desire for improved technology in its systems in production/modification, and the latter because of its desire to induce DoD to increase its spending. The result of a reduced R & D delay, therefore, was observed to strongly influence the effect that Technological Opportunity has on the system.

As reflected in the above, the system delays were viewed as having considerable impact on the system's behavior. It is important to note that during the time that it takes to reduce a specific mission area threat through increases in capability, it is highly probable that the enemy levels of capability have changed in both magnitude and direction, socio-economic conditions have changed, and, in general, the conditions influencing the original decisions have changed. This dynamic characteristic was seen as an inherent property of not only the acquisition process but of all systems.

Summary of Causal Loop Analysis

The analysis presented above reflects the transformation of the research data into a causal loop diagram

of the DoD major system acquisition process. It was conducted within the contextual setting resulting from a world view of the process. The causal loop, and the links making up that loop, were explained in some detail. Within the causal loop system itself, seven causal loops resulted from the assembly of the causal links, five negative and two positive. These causal loops represented the three mechanisms of resource allocation, threat reduction, and growth inherent within the system. The behavior of the system was analyzed and it was observed that DoD's internal control has a major influence on the system's behavior. Also, it was shown that six major delays impact on the system's behavior. It can be seen, therefore, that a significant portion of the system's behavior has been modeled through the construction of the causal loop diagram, thereby facilitating the development of the system dynamics flow diagrams.

Chapter 4

FLOW DIAGRAMS

This chapter presents and describes the flow diagrams that were developed from the results of the causal loop analysis discussed in Chapter 3. The flow diagrams represent the translation of the causal links and loops into a system of rates, levels, information flows, and delays.

To facilitate the task of translating the causal loop model into a flow diagram model, the three causal loop mechanisms discussed in Chapter 3 were flow diagrammed separately. Flow diagrams were developed for Resource Allocation, Threat Reduction, and Growth from their respective causal loops. Figures 18, 19, and 20 reflect the flow diagrams of these mechanisms. The separate flow diagrams were then combined to form a single flow diagram. This single flow diagram reflects the basic system dynamics model that was the objective of this research. Figure 21 depicts this system flow diagram.

| Symbol | Table |
|--------|--------------------------------|
| AT | Applied Technology |
| CST | Current System Technology |
| DoD | Department of Defense |
| EMAC | Enemy Mission Area Capability |
| LF | Loss Function |
| MAC | Mission Area Capability |
| MAS | Mission Area Spending |
| MAWS | Mission Area Weapon Systems |
| MT | Manufacturing Technology Delay |
| PMAT | Perceived Mission Area Threat |
| PROD | Production Delay |
| STP | System Technology Perception |
| TO | Technological Opportunity |
| WSLR | Weapon Systems Loss Rate |

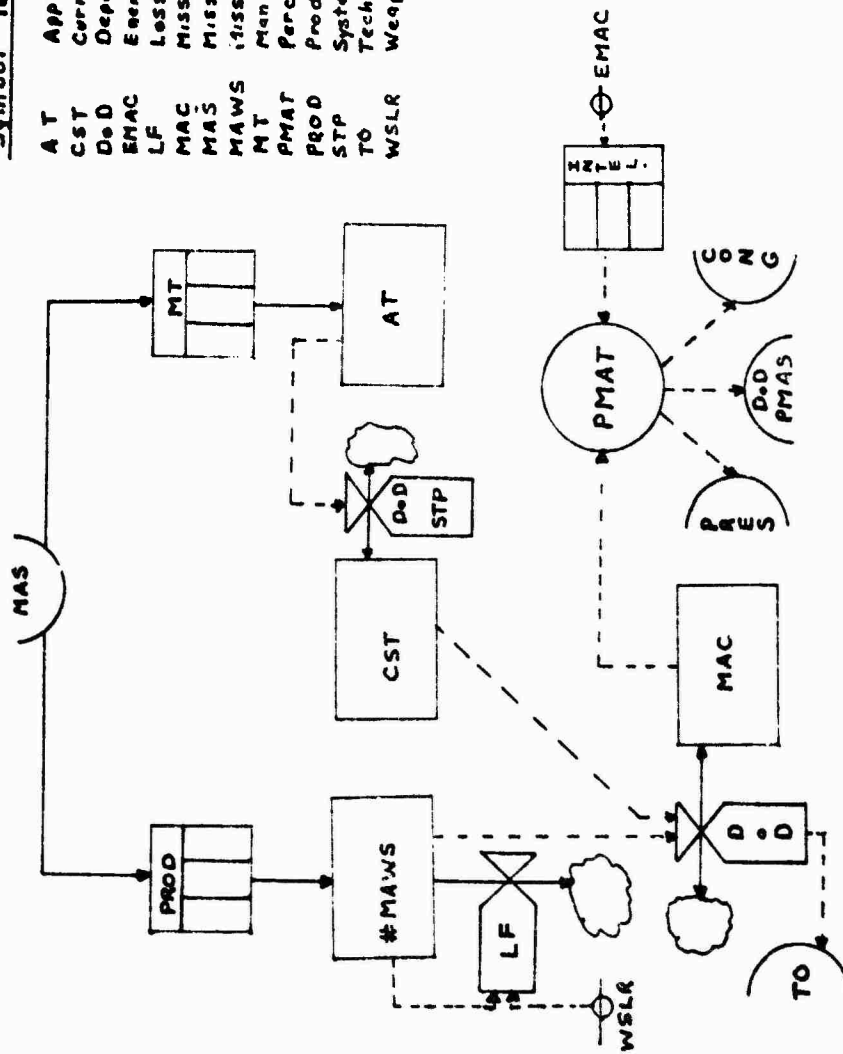
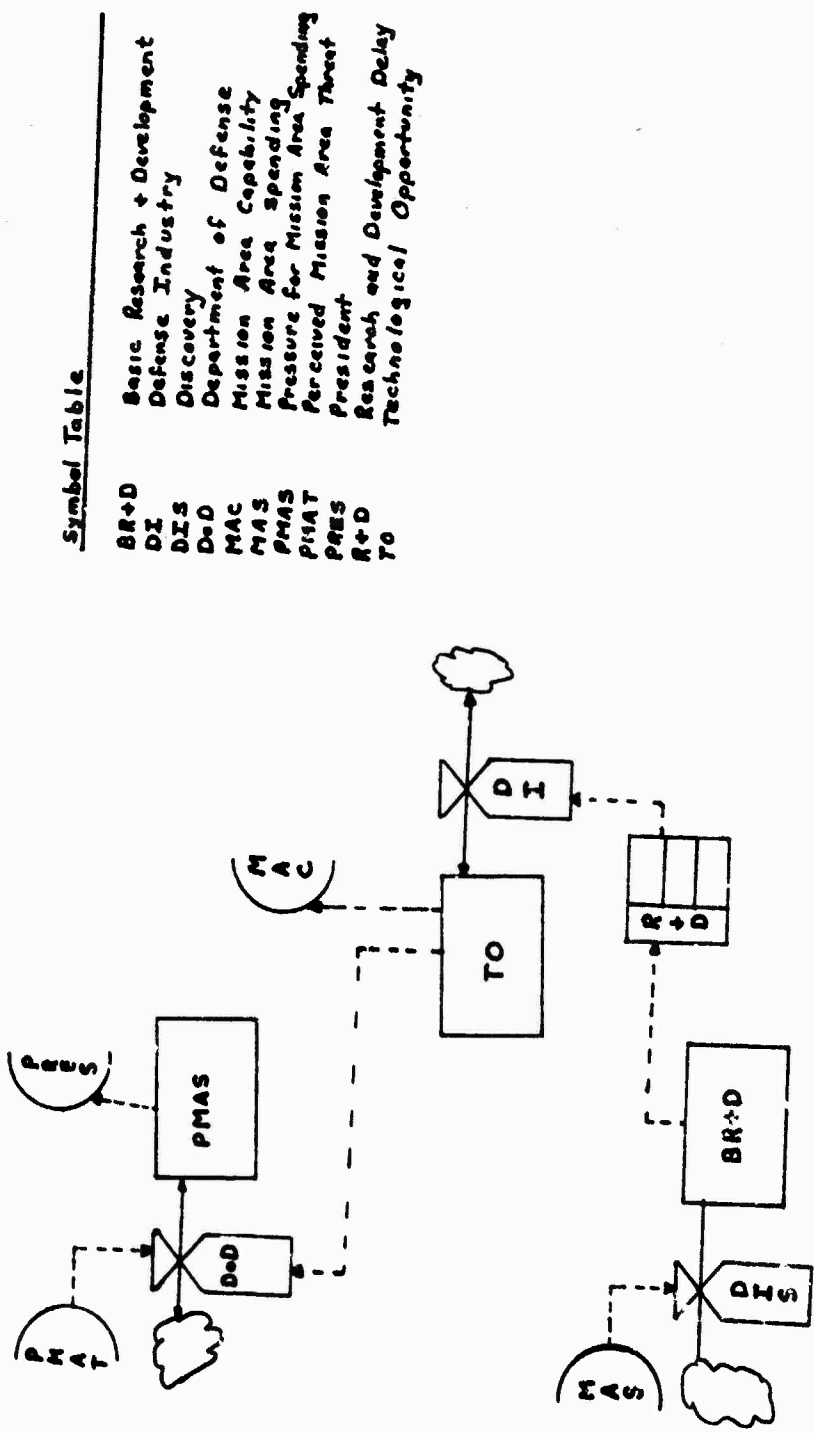

Figure 19
Threat Reduction Flow Diagram



Symbol Table

- BR+D Basic Research + Development
- DI Defense Industry
- DIS Discovery
- D+D Department of Defense
- MAC Mission Area Capability
- MAS Mission Area Spending
- PMAS Pressure for Mission Area Spending
- PMAT Perceived Mission Area Threat
- PRES President
- R+D Research and Development Delay
- TO Technological Opportunity

Figure 20
Growth Flow Diagram

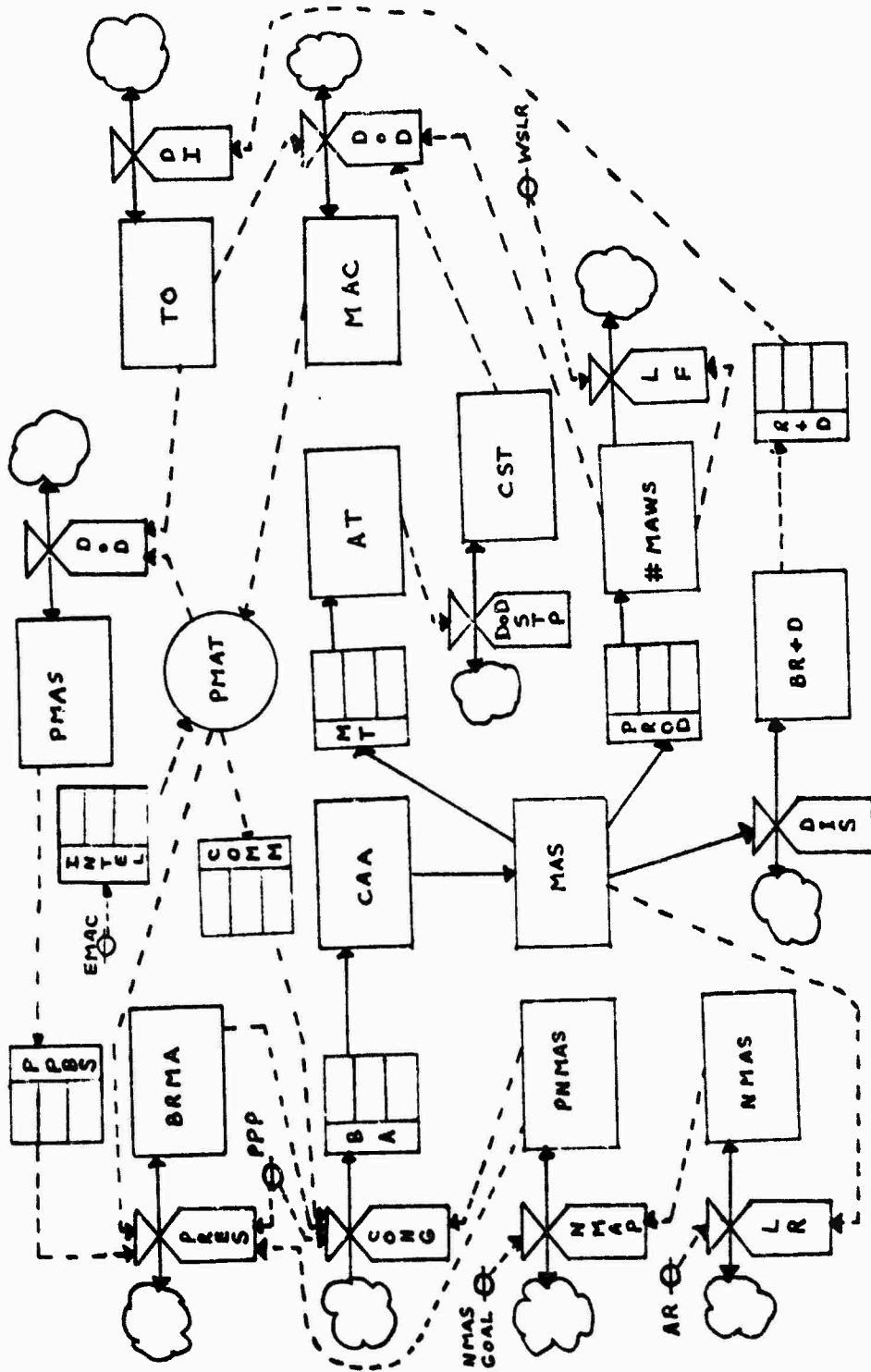

Figure 21

System Flow Diagram

The flow diagrams presented in this research effort represent only the initial step in the development of a complete, computerizable, system dynamics model. Because it is the first step, there is more of a correspondence between the causal loop diagrams and the flow diagrams than would be seen in the completely operationalized flow diagrams. As a result, some of the diagramming presented here is not, in the purest sense, in consonance with the fully developed system flow diagrams shown in Industrial Dynamics (4). Liberties were taken in the flow diagramming so as to allow the diagrams to correspond as closely as possible to the causal loops. This made the translation of the loops to flow diagrams both clearer and simpler. In the discussions of the flow diagrams that follow, special note is made when such liberties were taken.

In addition to the symbols used in Chapter 2, the flow diagrams presented in this chapter use three additional symbols: a circle, a small circle with a line through it, and an arc/semi-circle. The circle is used to represent an auxiliary parameter. In general, an auxiliary parameter is one that is solely a function

of two or more inputs. These inputs may be from another auxiliary, or from a level. For example, in the development of the flow diagrams the parameter Perceived Mission Area Threat was seen as such an auxiliary variable (see Figure 19). Perceived Mission Area Threat (PMAT), as addressed in Chapter 3, was depicted as solely a function of the level of Mission Area Capability (MAC) and the level of Enemy Mission Area Capability (EMAC); that is, threat was seen as a function of the differences between these two parameters.

The second symbol, a circle with a line through it, is used to show the input of an exogenous parameter into the system. The level of Enemy Mission Area Capability, mentioned above, is an example of such an exogenous parameter; as is Populace Political Pressure (PPP). Both these exogenous parameters are depicted using the lined through circle (see Figures 18 and 19).

The last symbol that was added is the arc (or semi-circle). This symbol is used to indicate a parameter that is either an input or an output of the particular flow diagram being reviewed. It is used as a transfer

device to show the flow of material or information between separate flow diagram figures. For example, Perceived Mission Area Threat (PMAT) is shown in Figure 18 as inputting flow to the Planning, Programming, and Budgeting System delay. Mission Area Spending, on the other hand, is shown in the same figure as outputting flow to the Production delay (PROD), Manufacturing Technology delay (MT), and the Discovery (DIS) decision function. As is depicted in the figure, the arc was used to symbolize these transfer actions.

The remaining sections of this chapter explain the structure of the flow diagrams. The behavior of the flow diagram model was seen as essentially unchanged from the causal loop system behavior described in Chapter 3, and therefore, the flow diagrams are discussed from the viewpoint of how they relate to the causal loops and links. The following discussions do not delve deeply into the interactive and causal relationships which were presented in Chapter 3.

Resource Allocation Flow Diagram

Figure 18 is the Resource Allocation Flow Diagram that was derived from the causal loops shown in Figure 13

of Chapter 3. It reflects the resource allocation mechanism of the acquisition process. This mechanism, as was discussed in Chapter 3, models the controlling influence that limited resources play in restricting spending growth.

In Figure 18, five levels are shown. These levels are synonymous with the five parameters shown in Causal Loops "a" and "b" of Figure 13, and represent the levels from which information is seen to flow to the decision functions. The levels in the figure are: Budget Request for Mission Area (BRMA), Congressional Authorization Appropriation (CAA), Mission Area Spending (MAS), Non-Mission Area Spending (NMA), and Pressure for Non-Mission Area Spending (PNMA). With the exception of BRMA, the names and concepts of the levels are the same as those depicted in the causal loops. Budget Request for Mission Area (BRMA) was seen to capture the Presidential Pressure for Mission Area Spending. As noted in Chapter 3, the real measure of such Presidential pressure was perceived to be the emphasis a mission area received in the Presidential Budget.

These five levels are controlled by four decision functions: President (PRES), Congress (CONG), Resource

Limitation (RL), and Non-Mission Area Populace (NMAP). The President, the Congress, and the Non-Mission Area Populace were seen as the explicit or overt controllers, while the Resource Limitation decision function was perceived to be an implicit decision function. The President and Congress are fairly obvious choices as decision functions in the resource allocation mechanism. The Non-Mission Area Populace, however, may not appear so obvious. This decision function was seen as the collective embodiment of those groups and/or individuals who were adversely affected by decreases in Non-Mission Area Spending. They were perceived to control the level of Pressure for Non-Mission Area Spending (PNMAS). The Resource Limitation (RL) decision function was seen as representing the body of economic principles governing the allocation of resources. It was viewed as an implicit decision function. That is, the Resource Limitation decision function controls resources on the basis of economic principles rather than on the basis of a changeable or controllable policy.

The basic structure of the Resource Allocation Flow Diagram is reflected in the arrangement of these

levels and decision functions along with their corresponding information and material flows. This structure, as portrayed in Figure 18, is shown to duplicate the system structure implied by the Figure 13 causal loops. In Figure 18, the President is depicted as controlling the level of the Budget Request for Mission Area (BRMA) based on information flows from DoD Pressure for Mission Area Spending (PMAS), Populace Political Pressure (PPP), Perceived Mission Area Threat (PMAT), and Pressure for Non-Mission Area Spending (PNMAS). As in the causal loop diagram, Pressure for Mission Area Spending is shown to be delayed by the Planning, Programming, and Budgeting System (PPBS).

Congress is shown in the figure as controlling the flow of funds into the level of Congressional Authorization Appropriation (CAA). A delay in this flow, called the Budget Approval (BA) delay, was added to reflect the actual delay that occurs between Presidential Budget submission and the actual authorization/appropriation of funds. Congress is shown as being influenced by Populace Political Pressure, Perceived Mission Area Threat, and Pressure for Non-Mission Area

Spending. The level of the Budget Request for the Mission Area (BRMA) is also shown as an input into the Congressional decision function. These inputs are reflected as information flows from the respective sources into the Congressional decision function. In the case of Perceived Mission Area Threat, the information flow is shown being delayed by the Communications (COMM) delay before entering the Congressional decision function.

In controlling the level of authorization/appropriation, Congress also controls Mission Area Spending (MAS). This is depicted by the straight line from CAA to MAS. The MAS flows out of the diagram into the Discovery (DIS) decision function, the Production (PROD) delay, and the Manufacturing Technology (MT) delay. It is also depicted as influencing the level of Non-Mission Area Spending through an information flow to the implicit decision function Resource Limitation (RL). The RL decision function is shown as receiving information on Available Resources (AR). This input is shown in the diagram by the information flow from the exogenous parameter AR to the RL decision function. As used in

the flow diagram, the Available Resources parameter is defined to be the measure of buying power of the government. The Resource Limitation decision function is shown controlling the level of Non-Mission Area Spending (NMAAS) based on its two information flows.

The level of Non-Mission Area Spending is sensed by the Non-Mission Area Populace decision function through an interconnecting information flow. This decision function compares the Non-Mission Area Spending information with the Non-Mission Area Spending Goal and adjusts the level of Pressure for Non-Mission Area Spending (PNMAAS). The Non-Mission Area Spending Goal represents the desired level of spending for all non-mission area activities. The difference between the desired level, represented by the goal, and the actual level, represented by the level of Non-Mission Area Spending (NMAAS), was seen as a factor in determining Pressure for Non-Mission Area Spending. The level of PNMAAS is shown as being fed back to the President and Congress, thereby completing the looping structure.

To operationalize the flow diagram, the levels of Budget Request for MA (BRMA), Congressional Authorization Appropriation (CAA), Mission Area Spending (MAS),

and Non-Mission Area Spending (NMAAS) could be measured in dollars, percent of the total budget, or percent of Gross National Product (GNP). Similarly, Available Resources (AR) and the Non-Mission Area Spending Goal (NMAAS Goal) could also use these parameters. Measures for Populace Political Pressure (PPP), DoD Pressure for Mission Area Spending (DoD PMAS), and Perceived Mission Area Threat, however, are not so easily discerned. Possible measures of PPP could be obtained through public survey, or data collection and analysis of some populace behavioral characteristic such as number and types of demonstrations held, or the number of articles in non-military publications whether for or against military spending. Determining public opinion is a difficult task; however, it was perceived that the PPP input was of significant importance to the system model and, therefore, it should not be deleted from the model solely because of the difficulty in its measurement. It was felt that even some intuitive estimate of public opinion should be used in the model to represent the system behavior.

Similarly, the variables of Perceived Mission Area Threat (PMAT), and DoD Pressure for Mission Area

Spending (DoD PMAS) are seen to be difficult to measure, yet their importance to the model dictates their presence. It seems reasonable to assume that analysis of surrogate phenomena, such as those mentioned for PPP above, and some intuitive reflection could supply the necessary data to operationalize these variables, and computerize the system dynamics model started by the research. This perception holds for all the variables discussed thus far as well as those discussed in the remaining portion of the flow diagram.

Parameters such as the difference in total ICBM megatonnage (or throw weight) between DoD and an enemy, or the difference in total ton-miles of cargo carrying capability available might serve as surrogates for PMAT. Similarly, the mission area percentage of the DoD budget request to the President, or the number of new mission area systems may provide insight into the amount of pressure DoD exerts in a specific mission area.

In summary, the flow diagram depicts the mechanism through which DoD receives dollars necessary for operation. Those dollars flow from this mechanism via Mission Area Spending into the Threat Reduction mechanism.

Threat Reduction Flow Diagram

The threat reduction mechanism flow diagram is shown in Figure 19 and was derived from the causal loops shown in Figures 14 and 15 of Chapter 3. In Figure 19, the flow from Mission Area Spending (MAS) is shown entering from the Resource Allocation flow diagram, and simultaneously flowing through the Production (PROD) and Manufacturing Technology (MT) delays into the Number of Mission Area Weapon Systems (#MAWS) level and Applied Technology (AT) level, respectively. This figure reflects the application of funds to increase the number of weapon systems and obtain a higher level of applied technology.

It should be noted here that funding is shown as being directly transformed into non-funding parameters; i.e., Mission Area Spending (funds) are transformed directly into number of Mission Area Weapon Systems and level of Applied Technology solely by means of delays. This direct transformation of one type of parameter to another type is a deviation from standard system dynamics modeling procedures; however, for the sake of clarity and simplicity in presentation this liberty was taken.

Returning to Figure 19, as Mission Area Spending is shown being transformed into Mission Area Weapon Systems, there is also a loss or draining away of weapon systems. This flow represents the loss of weapon systems out of the level for all causes (e.g., deterioration, accident, or obsolescence). The control of this flow is a result of a decision function called the Loss Function (LF). It acts using a parameter called the Weapon System Loss Rate (WSLR), and weapon system level information. The WSLR is shown as an exogenous variable. In effect, the Loss Function permits a more realistic view of the acquisition process, as lost systems must also be replaced in order to maintain capability.

Changes in the level of Applied Technology, due to changes in the level of Mission Area Spending, are shown as influencing the level of Current System Technology through an information flow to a decision function called the DoD System Technology Perception (DoD STP). This decision function represents the intuitive averaging that was perceived to take place within DoD when it assesses the level of technology across a total mission area. In addition to the information flow from Applied Technology, DoD STP is shown

receiving information about the number of Mission Area Weapon Systems through a second information flow.

It can be seen that the Applied and Current System Technology levels could be quantified through the use of such variables as airspeed, bomb carrying capacity, or cargo capacity. In the case of Applied Technology, technological level could be evaluated on the basis of measuring selected system variables of systems in production. Current System Technology, on the other hand, could be evaluated by averaging selected system variables across the mission area fleet, or more simply, use average age as a measure of average mission area technological level. This latter method of assessing the level of technology was perceived to be the one most used.

The level of Mission Area Capability (MAC) is depicted as being controlled by the DoD decision function based on the number of Mission Area Weapon Systems, the Current System Technology (CST), and Technological Opportunity (TO). As discussed in Chapter 3, TO acts as a "spoiler" and detracts from the DoD perception of capability per system received from the Current

System Technology (CST) information input. Technological Opportunity could be operationalized by comparing defense industry technology claims with the average values embodied in CST. In effect, TO is seen to cause DoD to "drain off" some of the capability from its MAC level.

Absolute capability, as represented by MAC, was not seen to be valid by itself. As a result it is difficult to operationalize capability without making some sort of comparison. This perception is reflected in Figure 19 by the comparison of MAC with Enemy MA Capability (EMAC) to form the auxiliary variable called Perceived Mission Area Threat (PMAT). The EMAC is shown as being delayed by the Intelligence delay (Intel). The Intelligence delay reflects the time necessary to gather sufficient mission area capability data about an enemy.

Perceived MA Threat, as discussed throughout this research, was conceived as essentially being the level of EMAC minus the level of MAC, with the magnitude of this difference being an indicator of the degree of threat perceived. The perception of threat pervades the entire system as reflected in the functions it affects: i.e., President, Congress, DoD, and although not specifically shown, the populace.

In summary, the Figure 19 flow diagram depicts the mechanism for reducing threat through increased capability. The mechanism is influenced from outside by Mission Area Spending (MAS), Enemy MA Capability (ENMAC), and Technological Opportunity (TO). Perceived MA Threat (PMAT) is shown outputting information to decision functions in both the Resource Allocation Flow Diagram (Figure 18) and the Growth Flow Diagram (Figure 20), the next diagram to be discussed.

Growth Flow Diagram

Figure 20 shows the flow diagram for the growth mechanism derived from the causal loops shown in Figure 16 of Chapter 3. This figure depicts the effects of Mission Area Spending (MAS) on Technological Opportunity (TO), and the combined effect of threat and TO on the DoD Pressure for Mission Area Spending.

Perceived Mission Area Threat (PMAT) is shown as directly influencing the DoD decision function in its control of the Pressure for Mission Area Spending level. The DoD decision function is also shown as being influenced by Technological Opportunity (TO) through an information flow from that level.

This flow represents the defense industry claims and advertising about the potential levels of technology achievable. It is interesting to note that the effect an increase in Technological Opportunity has on PMAS is very similar to the effect produced by an increase in threat. That is, both increase pressure for spending. As reflected in the GAO report (19:1-4), DoD perceived increases in U.S. technological opportunity as also being probable increases in enemy technological opportunity. In essence, this characteristic of the system implies that DoD does not distinguish between increases in enemy threat and increases in technological opportunity, and for practical purposes they are treated the same.

The defense industry (DI) is shown as the controlling decision function of the TO level and bases its actions on the level of technological breakthrough achieved by Basic Research and Development (BR&D). Such R&D is delayed, as is shown, by the R&D delay. The level of technological breakthrough is seen as difficult to operationalize. It appears, however, that successful laboratory results can be extrapolated into parameters

to get some measure of this characteristic. For example, the ability to make a lightweight, high-strength composite material in the laboratory could be translated into a lighter weight for aircraft, increased parts durability, or increased airspeed. Such extrapolations are limited only by the imaginations of the engineers, and the ability of their firms to convince DoD of their technological feasibility. The level of Basic R&D is shown being influenced by the level of Mission Area Spending (MAS). Therefore, in this flow diagram Mission Area Spending is shown driving the pressure for more spending, as a result of the policies of the DoD and defense industry decision functions.

It was noted in the construction of this flow diagram that the ability of DoD to resist the influences of the defense industry's Technological Opportunity strongly influences the behavior of the whole system. That is, if DoD does not respond to increases in Technological Opportunity with the same magnitude as it does to increases in threat, then one of the growth loops is constrained. The direct reaction of DoD to

technological opportunity was seen as one of the amplified policies that exists within the DoD major system acquisition process, and is perceived to be an area of importance for future examination.

System Flow Diagram and Summary

Figure 21 depicts the complete flow diagram resulting from combining the three previously presented diagrams. It represents the completion of the research objective--a conceptual model of the DoD major system acquisition process in its environment. The flow diagram, and the discussions in this and the previous chapter reflect the authors' perceptions and observations of the acquisition process. Such perceptions and observations are of necessity generic and reflect aggregation of the data gathered. The flow diagrams, the causal loops, and their descriptions are intended by the authors to facilitate further research into the problems of the acquisition process by providing increased insight into the total system within which the process functions.

The system flow diagram itself provides a graphical representation of the process and its major elements. The diagram makes it possible to see how changes to one part

of the system have decided effects on the other parts. This alone appears to be a valuable contribution. Looking at the multitude of recommendations for improvement made by both Fox (4) and the Commission on Government Procurement (14), the possible effects of their recommendations can be visualized through the use of the flow diagram. For example, as a result of the Commission on Government Procurement report, OMB Circular A-109 was written (3:1). This document required DoD to verify its needs based more on mission area threat, than on technological opportunity (3:4). The total effect of this document has yet to be realized; however, the flow diagram suggests that the intent of the circular is to reduce the direct effect that Technological Opportunity (TO) has had on the Pressure for Mission Area Spending (PMAS). The circular does appear to neglect, however, the indirect effect that Technological Opportunity (TO) is perceived to have on Pressure for Mission Area Spending through the "spoiling" effect on Mission Area Capability. Therefore, it can be conceived that this effect of TO on Mission Area Capability may increase such that Perceived Mission Area Threat is increased. Increased

Perceived Mission Area Threat leads to increased Pressure for Mission Area Spending which may balance off the decrease in pressure that the OMB Circular A-109 was to effect. Therefore, the net result of no change could be seen to result despite the reduction in the direct TO effect on the Pressure for Mission Area Spending.

Through the results reflected in the flow diagrams of this chapter, and in the causal loop analysis results of Chapter 3, the major objectives of this research were felt to be accomplished. The role of the DoD major system acquisition process within the framework of national goals and policies has been described. The factors influencing the process have been examined and analyzed at an aggregated and generic level. Both causal loop and flow diagram models were developed that form a framework within which currently available data may be used to further develop a system dynamics model. And finally, the models have shown some areas that may be fertile grounds for future exploration. As stated in the beginning of this chapter, the models developed here represent only the initial step in modeling the DoD major system acquisition process.

Chapter 5

CONCLUSIONS AND RECOMMENDATIONS

In this final chapter, conclusions and recommendations for further research are presented. These final comments are a result of an increased understanding of the DoD major system acquisition process that was gained in the accomplishment of this study. They also reflect the view that this effort is only the first step in a complete modeling of the acquisition process. The completed model will result in the recognition of the goals of the DoD major system acquisition process and the successful control of that process while accomplishing those goals.

Conclusions

As a result of this research, the authors observed the DoD major system acquisition process to be a complex, multi-goal activity of the U.S. Government. The process has been under attack for the past 20 years, and much has been written about how poorly it does the job of acquiring weapon systems. These criticisms of the process

appeared to be justified when the process is observed solely from the standpoint of how well the process accomplished its system acquisition job. However, the authors concluded that this view of the acquisition process may be inappropriate. That is, it appeared easy to criticize the DoD major system acquisition process if one took the view that the only purpose of that process is the efficient acquisition of weapon systems to meet U.S. defense needs. It does not appear, however, as easy to criticize the process if one views the process as an activity used by the government to further many national goals.

The above comments are not intended to imply that the acquisition process is without its controllable problems. However, the comments do infer that when one views the acquisition process from a wider perspective than that apparently taken by the critics, the process may be seen as having an inherently characteristic behavior that is the result of its multi-goal role. This inherent behavior of the process may not be controllable as long as the process is being used to accomplish national goals through implementation of national policy. Yet it may be this same behavior that

is seen as the cause of inefficient or ineffective acquisitions of major systems. For example, the authors generally perceived from fellow students and faculty at the Air Force Institute of Technology that the awarding of the contract to General Dynamics for the F-16 fighter was one based in part on the unemployment in the Ft. Worth-Dallas area and the large number of government-owned facilities in that area. Whether these suppositions are true or not, they serve the purpose for the following discussion.

From the standpoint of efficiently acquiring an effective weapon system, the awarding of the contract based in part on the level of unemployment and the amount of government facilities vacant could be seen to be contrary to the goal of efficient acquisition. On the other hand, if it is recognized that it is also a goal of the process to "promote the general welfare [9:26]," and that the acquisition process must also support this national goal, then such a decision to award a contract that satisfies both the above national goal, and the goal of "provide for the common defense [9:26]" can be seen to be less subject to criticism.

The authors believe that in taking a broader view of the acquisition process it is possible to discern what the inherent behavior of the process is, and how that process responds to a multiplicity of goals. From a determination of its inherent behavior, it is possible to ascertain the aspects of the process that impact negatively on effective or efficient acquisition, but whose modification should not degrade the accomplishment of the system's goals. In effect, it is believed that those who wish to improve the DoD major system acquisition process must understand not only the inner workings of the process, but they must understand all the goals inherent in the execution of that process. Also, those who wish to control the process must have a feeling for the total system effects of any changes. They must be able to recognize when the inherent behavior of the system can negate the control attempted through the changes. It is in this light that the recommendations for further research are made.

Recommendations for Further Research

The flow diagram model developed in this effort is recognized as being only the first step in the development of a complete system dynamics model of the acquisition

process. The conceptual model developed here is seen as the framework within which a less aggregated, less generic system dynamics model can be created. Such a model would not lose the inherent behavioral characteristics detailed in this effort.

The authors would like to see the relationships between system variables explored more fully so as to be able to quantify them in some manner (either intuitively or rigorously). Variables such as capability, threat, technological opportunity, or current system technology all are capable of being operationalized. The operationalizing suggestions presented in Chapter 4 may be good starting points for this quantification effort. From quantification it is possible to develop a computerizable system dynamics model. During the development of the flow diagram it was observed that this computerization was feasible by using the system dynamics approach and its associated computer program, DYNAMO (4).

Whether such a system dynamics model can be successfully developed is dependent upon the ability of those involved in the process to determine how the system can be expected to react to changes in policy, changes in enemy capability, and changes in the availability of

resources. The complete model would provide a means to understand more clearly the dynamic nature of the acquisition process, and would provide insight into means of controlling the process within the framework of the system's goals.

The task of building a complete system dynamics model is seen as a large one, yet the potential benefits derived from such a model are perceived to be substantial. It is the authors' hope that the research effort begun here will be continued.

SELECTED BIBLIOGRAPHY

A. REFERENCES CITED

1. Beer, Stafford. Decision and Control. New York: Jon Wiley & Sons, 1966.
2. Belden, Colonel David L., USAF, and Ernest G. Commack. Procurement. Washington: Industrial College of the Armed Forces, 1973.
3. Executive Office of the President. Office of Management and Budget. Major System Acquisitions. OMB Circular Number: A-109, Washington: Government Printing Office, April 5, 1976.
4. Forrester, Jay W. Industrial Dynamics. Cambridge, MA: The M.I.T. Press, 1961.
5. Fox, J. Ronald. Arming America. Boston: Harvard University Press, 1974.
6. Goodman, Michael R. Study Notes in Systems Dynamics. Cambridge MA: Wright-Allen Press, Inc., 1974.
7. Judson, Robert, Ph.D., Professor, Naval Post Graduate School, Monterey, CA. Personal interview. 27 December 1977.
8. Lorette, Richard J. "Major Acquisition Problems, Policy and Research," National Contract Management Journal, Winter 1976-1977, pp. 1-15.
9. Nelson, Randall H., and John J. Wuest The Primary Sources of American Government. New York: G.P. Putnam's Sons, 1962.
10. Scherer, Frederick M. The Weapons Acquisition Process: Economic Incentives. Boston: Division of Research, Harvard Business School, 1968.

11. Schoderbek, Peter P., et al. Management Systems: Conceptual Considerations. Dallas TX: Business Publications, Inc., 1975.
12. "The Military Balance 1977/78," Air Force, December, 1977, pp. 1-152.
13. "The Navy Under Attack," Time, May 8, 1978, pp. 14-24.
14. U.S. Congress. U.S. Senate Committee on Government Operations. Ad Hoc Subcommittee on Federal Procurement. Extract from Report of the Commission on Government Procurement. Volume 2, Part C, "Acquisition of Major Systems," December 1972. Committee Print, Washington: Government Printing Office, March 1974.
15. U.S. Department of Defense. Major System Acquisitions. DoD Directive 5000.1. Washington: Government Printing Office, January 18, 1977.
16. _____. Major System Acquisition Process. DoD Directive 5000.2. Washington: Government Printing Office, January 18, 1977.
17. U.S. Department of the Air Force. The Air Force Budget. AFP 172-4, Washington: Government Printing Office, March 1978.
18. U.S. Federal Procurement Institute. Study Plan, FPI Information Management Program, Draft #2, December 5, 1977.
19. U.S. General Accounting Office. The Process for Identifying Needs and Establishing Requirements for Major Weapon Systems in the Department of Defense. Washington: Government Printing Office, October 23, 1974.

B. RELATED SOURCES

Alchian, Armen A., and William R. Allen. University Economics. Belmont CA: Wadsworth Publishing Company, Inc., 1964.

Anthony, Robert N., and Regina E. Heizlinger. Management Control in Nonprofit Organizations. Homewood IL: Richard D. Irwin, Inc., 1975.

Blanchard, Benjamin S. Logistics Engineering and Management. Englewood Cliffs NJ: Prentice-Hall, Inc., 1974.

Brown, Harold, Secretary of Defense. Memorandum for Secretary of the Navy, Subject: Mission Need Statements and the "Type A" V/STOL Program, 1 April 1977.

Coulam, Robert F. Illusions of Choice: The F-111 and the Problem of Weapons Acquisition Reform. Princeton NJ: Princeton University Press, 1977.

"DoD Resource Management Systems: Planning-Programming-Budgeting System." Reading material to support course objectives of Financial Management in the Federal Government, RM 5.42, Air Force Institute of Technology, Wright-Patterson Air Force Base OH, February, 1977.

Executive Office of the President. Office of Management and Budget. Office of Federal Procurement Policy. Major System Acquisitions. OFPP Pamphlet No. 1, Washington: Government Printing Office, August, 1976.

Forrester, Jay W. Principles of Systems. Cambridge MA: Wright-Allen Press, Inc., 1968.

_____. World Dynamics. 2nd ed. Cambridge MA: Wright-Allen Press, Inc., 1973.

"Fourth Annual Soviet Aerospace Almanac," Air Force,
March, 1978, pp. 33-109.

Gardiner, Peter J., Ph.D. Professor, University of
Southern California, Los Angeles CA. Personal
interview. December 16, 1977.

"Historical Developments Leading to the Resource
Management Systems." Reading material to support
course objectives of Financial Management in the
Federal Government, RM 5.42, Air Force Institute
of Technology, Wright-Patterson Air Force Base OH,
March, 1976.

Kast, Fremont E., and James E. Rosenwig. Organization
and Management: A Systems Approach. 2nd ed.
New York: McGraw-Hill Book Company, 1974.

Lee, Lamar Jr., and Donald W. Dobler. Purchasing
and Materials Management: Text and Cases. 3rd ed.
New York: McGraw-Hill Book Company, 1977.

Lorette, Richard J., Ph.D. Professor, University of
Southern California, Los Angeles CA. Personal
interview. 16, 19, and 20 December 1977.

_____. "Do We Really Want Research on the Acqui-
sition of Major Weapon Systems?" National Contract
Management Journal, Winter 1976-1977, pp. 64-70.

_____. "The Relationship Between the Pressures on
the System Program Director and the Growth of
Weapon System Cost Estimates." Excerpts provided
by Dr. Lorette. Unpublished doctoral dissertation,
Harvard Business School, Boston, 1967.

McCarty, Dyke, and Major Thomas Valore, USAF. "The
Acquisition of Major Systems." Unpublished paper,
Air Force Institute of Technology, Wright-Patterson
Air Force Base OH, December 1976.

_____. "The Acquisition of Major Systems." Unpublished
paper, Air Force Institute of Technology, Wright-
Patterson Air Force Base OH, April, 1977.

Peck, Merton J. and Frederic M. Scherer. The Weapons Acquisition Process: An Economic Analysis. Boston: Division of Research, Harvard Business School, 1962.

Peterson, Willis L. Principles of Economics: Micro. 3rd ed. Homewood IL: Richard D. Irwin, Inc., 1977.

Porter, Lyman W., Edward E. Lawler, III., and J. Richard Hackman. Behavior in Organizations. New York: Mc-Graw-Hill Book Company, 1975.

Samuelson, Paul A. Economics. 8th ed. New York: McGraw-Hill Book Company, 1970.

U.S. Department of Defense. Armed Services Procurement Regulation. Sections I, III, VII, XIV, XV, XVIII, XX, XXIII, Appendix B, and Appendix E., 1 July 1976.

U.S. Department of the Air Force. Required Operational Capabilities (ROC). AFR 57-1. Washington: Government Printing Office, 30 May 1975.

_____. Stating Operational Needs. Draft Revision. AFR 57-1. Washington: Headquarters USAF/RDQ, 31 May 77.