

AD-A055977

TECHNICAL  
LIBRARY

AD

AD-E400 113

CONTRACTOR REPORT ARLCD-CR-78008

TNT EQUIVALENCY OF M10 PROPELLANT

F. L. McINTYRE

NASA NATIONAL SPACE TECHNOLOGY LABORATORIES

PAUL PRICE

PROJECT ENGINEER, ARRADCOM

MARCH 1978



US ARMY ARMAMENT RESEARCH AND DEVELOPMENT COMMAND  
✓ LARGE CALIBER  
WEAPON SYSTEMS LABORATORY  
DOVER, NEW JERSEY

APPROVED FOR PUBLIC RELEASE; DISTRIBUTION UNLIMITED.

The findings in this report are not to be construed as an official Department of the Army position.

#### DISPOSITION

Destroy this report when no longer needed. Do not return to the originator.

The citation in this report of the names of commercial firms or commercially available products or services does not constitute official endorsement or approval of such commercial firms, products, or services by the US Government.

REPORT DOCUMENTATION PAGE		READ INSTRUCTIONS BEFORE COMPLETING FORM
1. REPORT NUMBER Contractor Report ARLCD-CR-78008	2. GOVT ACCESSION NO.	3. RECIPIENT'S CATALOG NUMBER
4. TITLE (and Subtitle)  TNT EQUIVALENCY OF M10 PROPELLANT		5. TYPE OF REPORT & PERIOD COVERED  Final Report
		6. PERFORMING ORG. REPORT NUMBER
7. AUTHOR(s) F. L. McIntyre, NASA-NSTL P. Price, Project Engineer, ARRADCOM		8. CONTRACT OR GRANT NUMBER(s)  MIPR 816B60201 F4W5
9. PERFORMING ORGANIZATION NAME AND ADDRESS NASA National Space Technology Laboratories Edgewood Arsenal Resident Laboratory Bay St. Louis, MS 39520		10. PROGRAM ELEMENT, PROJECT, TASK AREA & WORK UNIT NUMBERS  ARRADCOM Project 5764285
11. CONTROLLING OFFICE NAME AND ADDRESS ARRADCOM ATTN: DRDAR-TSS Dover, NJ 07801		12. REPORT DATE March 1978
		13. NUMBER OF PAGES 57
14. MONITORING AGENCY NAME & ADDRESS (if different from Controlling Office) ARRADCOM ATTN: DRDAR-LCM Dover, NJ 07801		15. SECURITY CLASS. (of this report)  Unclassified
		15a. DECLASSIFICATION/DOWNGRADING SCHEDULE
16. DISTRIBUTION STATEMENT (of this Report)  Approved for public release, distribution unlimited.		
17. DISTRIBUTION STATEMENT (of the abstract entered in Block 20, if different from Report)		
18. SUPPLEMENTARY NOTES Tests were accomplished as part of the US Army Manufacturing Technology Program. The primary objective of this program is to develop, on a timely basis, manufacturing process techniques and equipment for use in the production of Army materials.		
19. KEY WORDS (Continue on reverse side if necessary and identify by block number) M10 Propellant                      Scaled blast pressure TNT equivalency                      Scaled distance Scaled positive impulse              Scaled time of arrival Geometric configuration		
20. ABSTRACT (Continue on reverse side if necessary and identify by block number) Peak, side-on blast overpressure and scaled, positive impulse have been measured for M10 single-perforated propellant, web size 0.018 inches, using configurations that simulate the handling of bulk material during processing and shipment. Quantities of 11.34, 22.7, 45.4, and 65.8 kg were tested in orthorhombic shipping containers and fiberboard boxes. High explosive equivalency values for each test series were obtained as a function of scaled distance by comparison		

## 20. ABSTRACT (Continued)

to known pressure, arrival time and impulse characteristics for hemispherical TNT surface bursts. The equivalencies were found to depend significantly on scaled distance, with higher values of 150-100 percent (pressure) and 350-125 percent (positive impulse) for the extremes within the range from 1.19 to 3.57 m/kg<sup>1/3</sup>. Equivalencies as low as 60-140 percent (pressure) and 30-75 percent (positive impulse) were obtained in the range of 7.14 to 15.8 m/kg<sup>1/3</sup>. Within experimental error, both peak pressure and positive impulse scaled as a function of charge weight for all quantities tested in the orthorhombic configuration.

## ACKNOWLEDGEMENTS

The author wishes to acknowledge the technical assistance of the Kellar Range field test crew of the Computer Sciences Corporation; D. A. Martin of the Edgewood Arsenal Resident Laboratory; Darl Westover and Joseph Caltagirone of ARRADCOM, Dover, NJ.

## SUMMARY

M10 propellant, 0.018 inch web, single perforation, was detonated in configurations representative of orthorhombic shipping boxes, and a simulated in-plant conveyor bucket. Blast output parameters were measured and TNT equivalency was computed based on comparison with TNT hemispherical surface bursts. The results of these tests are represented in the table below and in figures on the following pages. Within experimental error, the pressures and impulses from the orthorhombic and conveyor bucket configurations (11.34 kg, 22.68 kg, 45.36 kg, 65.77 kg) scaled according to the cube root of charge weight.

Configuration Mass	Pressure (P) and Impulse (I) TNT Equivalency (%) at Scaled Distance											
	1.19m/kg <sup>1/3</sup> (3.0ft/lb <sup>1/3</sup> )		1.61m/kg <sup>1/3</sup> (4.05ft/lb <sup>1/3</sup> )		2.13m/kg <sup>1/3</sup> (5.38ft/lb <sup>1/3</sup> )		3.57m/kg <sup>1/3</sup> (9.0ft/lb <sup>1/3</sup> )		7.14m/kg <sup>1/3</sup> (18.0ft/lb <sup>1/3</sup> )		15.9m/kg <sup>1/3</sup> (40ft/lb <sup>1/3</sup> )	
	P	I	P	I	P	I	P	I	P	I	P	I
Ratio h/w < 1 11.34 kg 22.7 kg 45.36 kg	115	330	145	280	140	130	90	65	60	70	90	75
Ratio h/w > 1 45.36 kg 65.77 kg	165	210	140	330	150	165	90	80	75	60	140	30

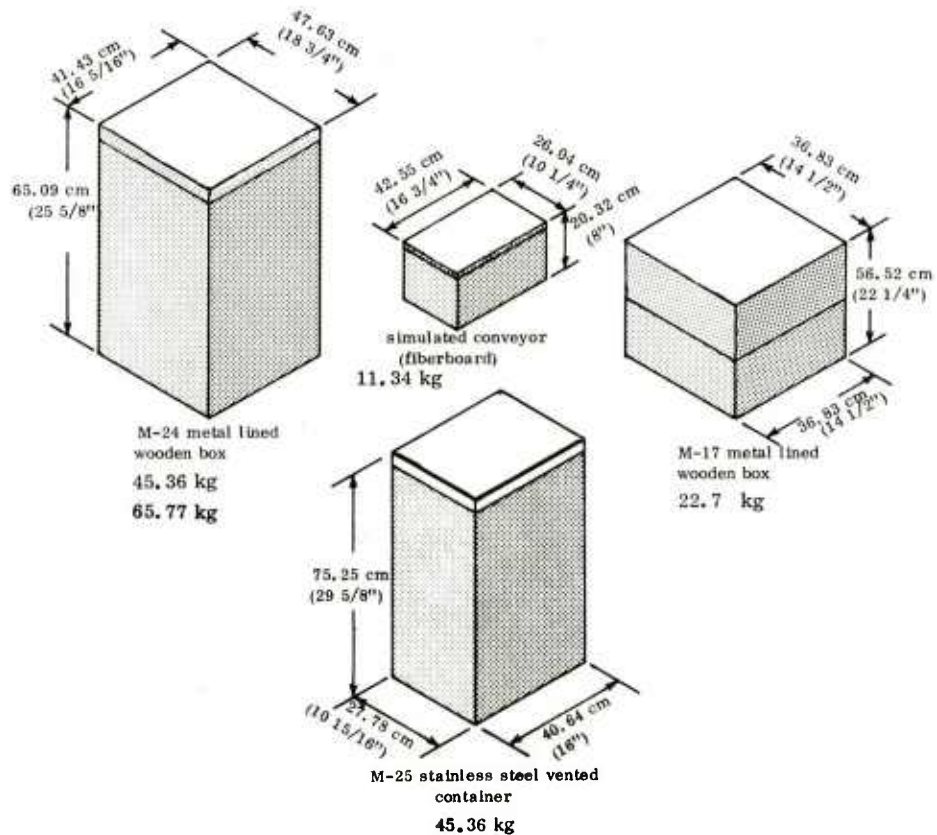

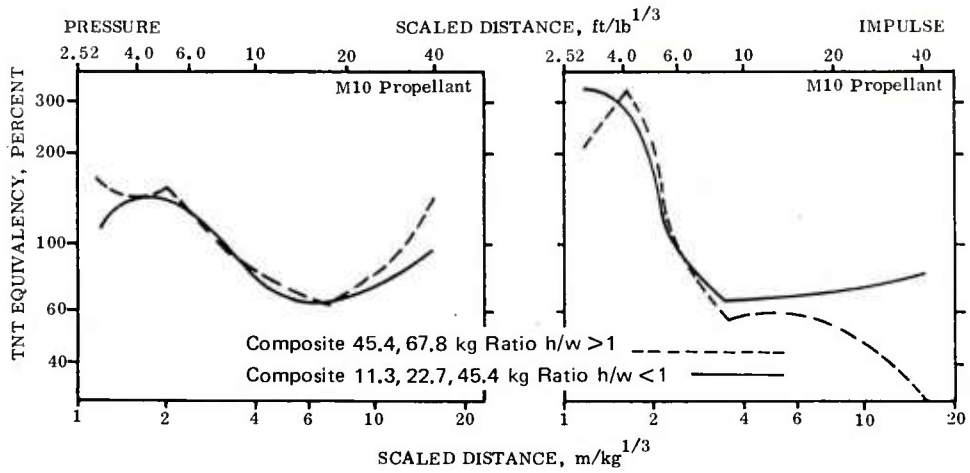
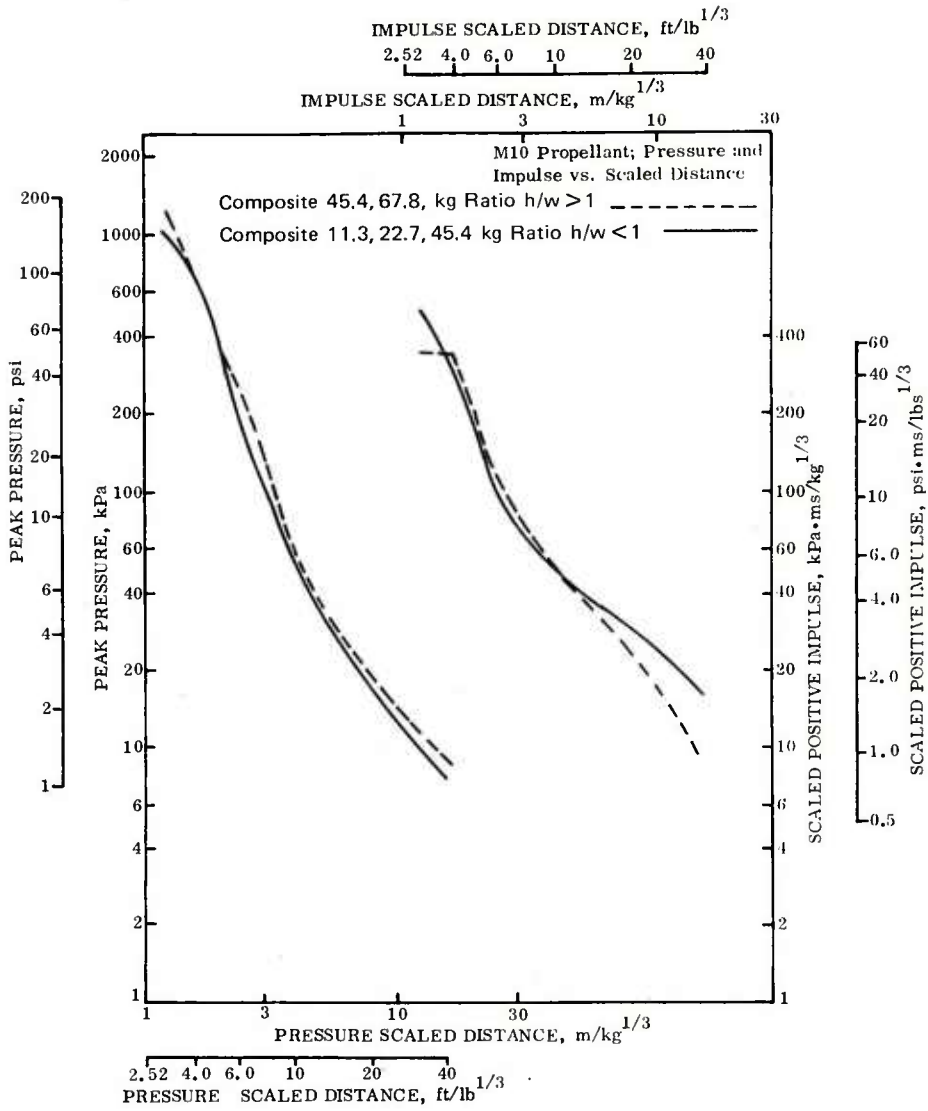

## TABLE OF CONTENTS

	Page No.
Introduction	1
Background	1
Objective	1
Material	1
Test Plan	2
Instrumentation	2
Results	6
Data Analysis	6
Test Results	7
Discussion	7
Conclusions	8
References	9
Appendixes	
A Field Data Sheets	25
B Selected Photographs	35
C Safety Approval	43
Distribution List	45
Tables	
1 Transducer Calibration and Placement	5
2 Summary of Test Results, 11.34 kg Charges	11
3 Summary of Test Results, 22.68 kg Charges	11
4 Summary of Test Results 45.4 Charges with a Ratio $h/w < 1$	12



5	Summary of Test Results 45.4 Charge in the M-25 Stainless Steel Vented Container with a Ratio $h/w > 1$	12
6	Summary of Test Results 65.77 kg Charges	13
7	Summary of Test Results of 11.34, 22.68 and 45.36 kg Charge Weight Combined with Ratio $h/w < 1$	13
8	Summary of Test Results of 45.4 and 65.8 Charge Weights Combined with Ratio $h/w < 1$	14
9	Fireball Duration and Diameter	14

## Figures

1	Test Container Configurations	3
2	Typical Charge Placement for Equivalency Tests	4
3	Test Area Showing Transducer and Camera Placement	4
4	Pressure and Impulse vs. Scaled Distance, 11.34 kg Charges	15
5	Pressure and Impulse vs. Scaled Distance, 22.68 kg Charges	16
6	Pressure and Impulse vs. Scaled Distance, 45.4 kg Charges	17
7	Pressure and Impulse vs. Scaled Distance, 45.4 kg Charge M-25 Stainless Steel Container Ratio $h/w = 1:0.4$	18
8	Pressure and Impulse vs. Scaled Distance, 65.77 kg Charges	19
9	Pressure and Impulse vs. Scaled Distance for Combined Weights of 11.34, 22.68 and 45.4 kg Charges with a Ratio $h/w < 1$	20

10	Pressure and Impulse vs. Scaled Distance for Combined Weights of 45.4, 65.8 kg Charges with a Ratio $h/w > 1$	24
11	Pressure and Impulse Equivalencies	22
12	Composite TNT Equivalency of M10 Propellant	23
13	Deviation From Cube-root Scaling of M10 Propellant	24

## INTRODUCTION

### BACKGROUND

Plans are currently underway for designing new and modernizing existing U.S. Army Production facilities where M10 propellant is loaded into munitions. Although all building and equipment designs have not been finalized, it is known that bulk quantities of this material will be found at various points in the load, assemble and pack (LAP) operations.

M10 propellant is a Class 7 (DOT Class B) material and is shipped in four types of containers, the type being dictated by the weight of the propellant to be shipped. For a quantity of 22.7 kg the required container is a M-17 metal lined wood box, Drawing Number 76-4-56. For quantities of 45.4 kg two types of containers, a M-24 metal lined wood box, Drawing Number 76-4-46 and a M-25 stainless steel vented container, Drawing Number 7549033 are used. The M-24 metal lined wood box is also used for quantities of 68.0 kg. The various shipping containers of M10 propellant will be received and stored in Stradley Igloos. The bulk material will then be weighed into 11.34 kg increments and transferred via bucket conveyor to the propellant charge preparation building.

Safety engineering and cost effectiveness considerations require knowledge of hazardous material characteristics as an input to facility design requirements. In this instance, specific data is required on the explosive output characteristics of M10 propellant in quantities and configurations representative of those found in processing.

### OBJECTIVE

The objective of this work was to determine the maximum output from the detonation of M10 propellant in terms of the airblast overpressure and positive impulse compared to known characteristics of a hemispherical surface blast of TNT.

### MATERIAL

The test material was Propellant, Explosive, Solid Class B Propellant M10, Type 2 (Lot numbers RAD 68725 and RAD 88725), 0.018 inch web, single perforation (SP) grain, containing 98 percent nitrocellulose (13.25 percent N), 1 percent potassium sulfate and 1 percent diphenylamine. The propellant was received from Radford Army Ammunition Plant in standard shipping boxes (Drawing Number 76-4-46) containing 65.8 kg net mass.

## TEST PLAN

Airblast output was evaluated for masses and configurations of M10 propellant representative of three shipping and in-plant situations. Physical characteristics of the test items were as follows:

- (1) An orthorhombic container, Figure 1(a), was used to simulate the conveyor bucket. Two-piece telescoping fiberboard boxes were fabricated and filled with 11.34 kg of M10 propellant.
- (2) M-17 metal-lined wood boxes, Figure 1(b), were used for charge weight of 22.68 kg. The box was approximately half full as shown in the figure.
- (3) M-24 metal-lined wood boxes, Figures 1(c, d), were used for 45.4 kg and 65.8 kg quantities of M10, with boosters placed as shown.
- (4) M-25 stainless steel vented container, Figure 1(e) was used for 45.4 kg quantities of M10 propellant.

A conical shaped booster charge of Composition C-4 high explosive was placed in the center of the top of each container, buried such that the apex was level with the top surface of the test material as shown in Figure 1(f). The booster was detonated with an engineers' special J-2 Blasting Cap inserted at the apex and embedded to the center of the cone. A single test for each configuration was performed using a booster equal to 1 percent by weight of the test charge, and subsequent visual observations indicated the absence of unburned propellant. However, since the TNT equivalent weight of C-4 is factored out during data analysis, 1.5 to 2 percent boosters were used to assure complete detonation in subsequent tests. Three or four tests were performed at each specified charge weight.

The test charge for each configuration was placed on a 0.61 by 0.61 by 0.0064m thick 1010 carbon steel witness plate in the center of the test area shown in Figure 2. The area was refurbished after each test subsequent to measurement of crater diameter and depth.

## INSTRUMENTATION

Twelve Susquehanna Instruments Model ST-7 side-on blast transducers were mounted in wooden blocks that were buried so that the sensor was at ground level in two arrays within the test area shown in Figure 3. Distances between transducers and charges were calculated to correspond to scaled distances of 1.19, 1.61, 2.13, 3.57, 7.14 and 15.87 meter/kg<sup>1/3</sup>. The transducers were individually calibrated prior to each test series with pressure pulses from a standard solenoid-actuated air pressure calibration fixture, adjusted to correspond to expected blast pressure on an assumed TNT equivalency of 100 percent. This calibration was verified initially by measuring free field blast pressures from 0.454 kg bare spherical charges of 50/50 pentolite. Signal line continuity and channelization were checked prior to each test. Details of

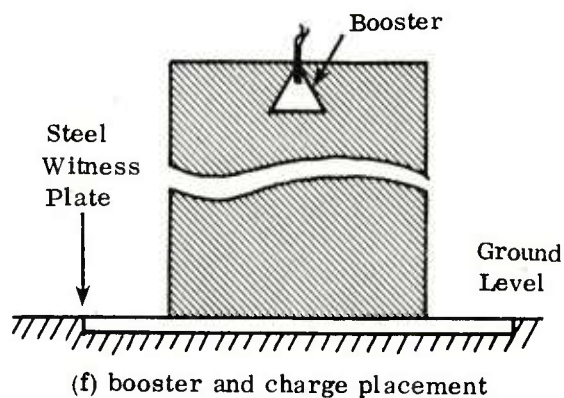
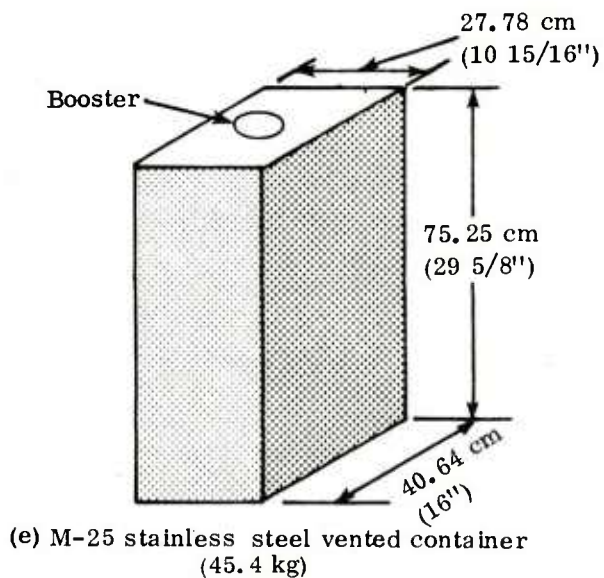
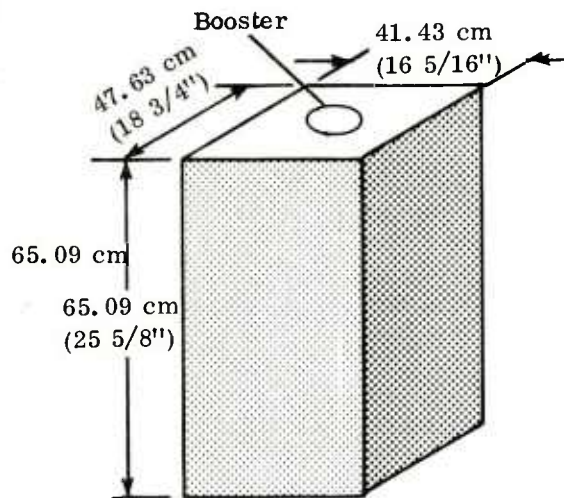
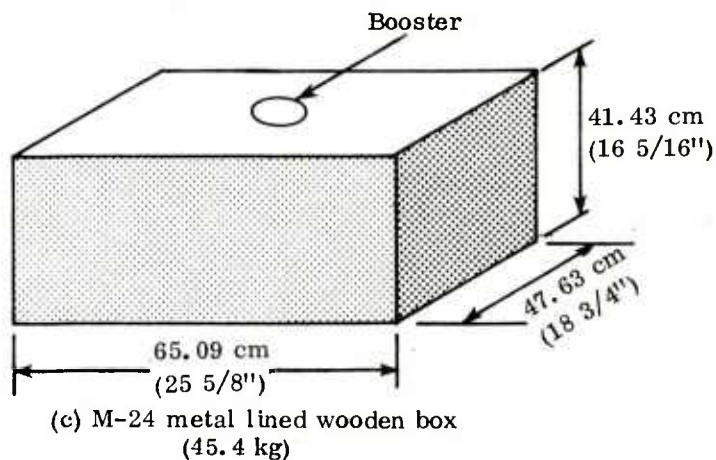
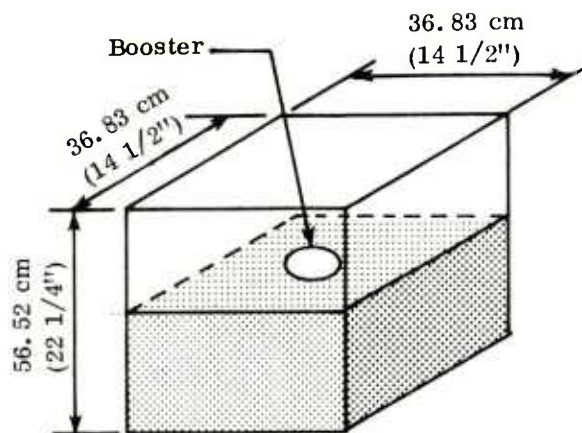
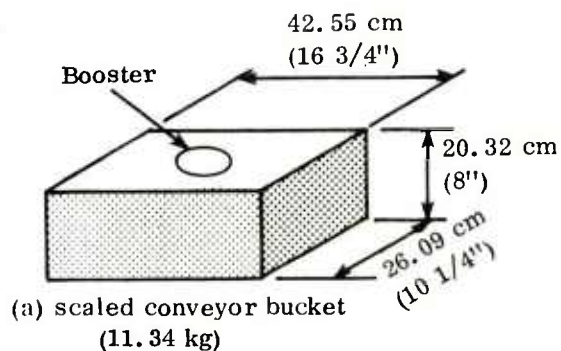

Figure 1. Test Container Configurations

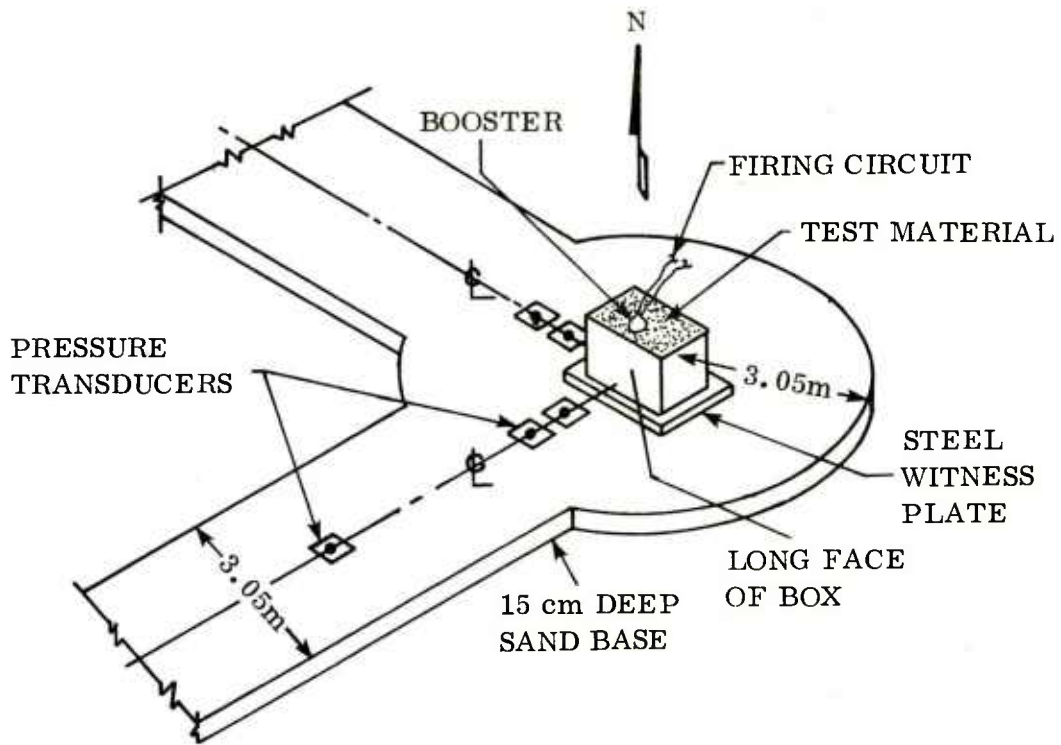

Figure 2. Typical Charge Placement for Equivalency Tests

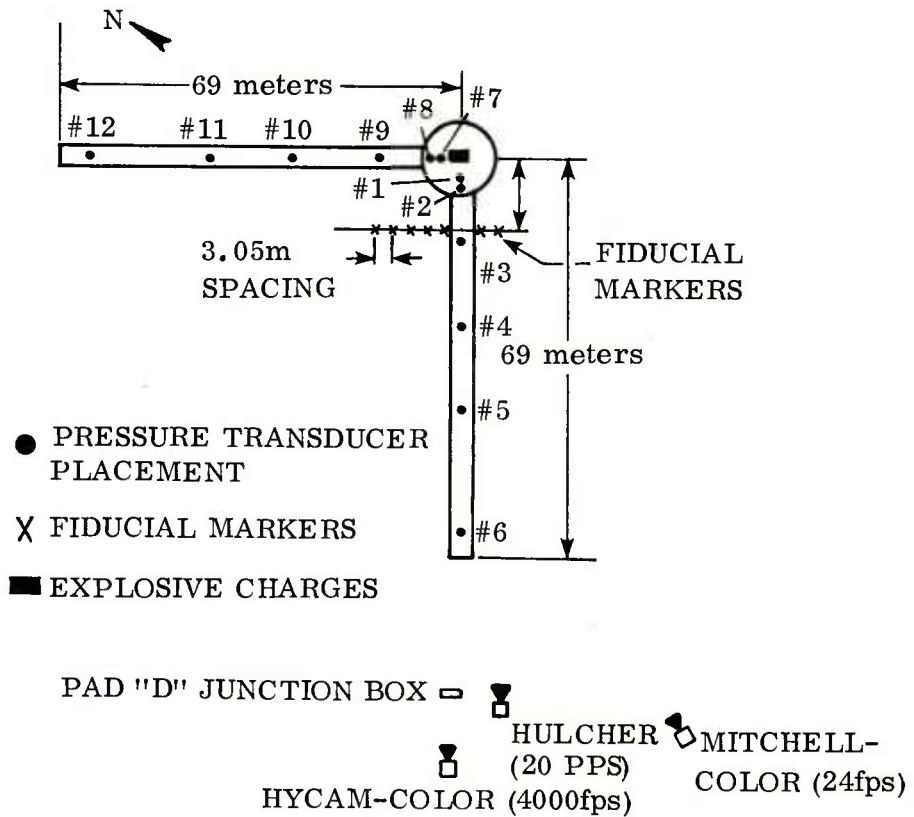

Figure 3. Test Area Showing Transducer and Camera Placement

distances between charge and transducers, calibration pressure and expected peak blast pressures at each distance are shown in Table 1.

Table 1. Transducer Calibration and Placement

Channel Number	Scaled Distance $m/kg^{1/3}$ ( $ft/lb^{1/3}$ )	Calibration Pressure kPa (psig)	Expected Pressure kPa (psig)	Distance in Meters (Ft) From Charge			
				Charge Weight 11.34 kg (25 lb.)	Charge Weight 22.68 kg (50 lb)	Charge Weight 45.4 kg (100 lb)	Charge Weight 65.8 kg (145 lb)
1, 7	1.19 (3.0)	689 (100)	868.6 (126.0)	2.67 (8.77)	3.37 (11.05)	4.24 (13.92)	4.80 (15.76)
2, 8	1.61 (4.05)	414 (60)	437.5 (66.35)	3.61 (11.84)	4.55 (14.9)	5.73 (18.80)	6.49 (21.28)
3, 9	2.13 (5.38)	207.8 (30)	250.5 (36.33)	4.80 (15.73)	6.04 (19.8)	7.61 (24.97)	8.61 (28.26)
4, 10	3.57 (9.0)	68.9 (10)	87.9 (12.74)	8.02 (26.32)	10.11 (33.2)	12.73 (41.77)	14.41 (47.28)
5, 11	7.14 (18.0)	34.5 (5)	24.9 (3.605)	16.04 (52.63)	20.21 (66.3)	25.47 (83.55)	28.82 (94.55)
6, 12	15.87 (40.0)	34.5 (5)	7.45 (1.081)	35.64 (117.0)	44.92 (147.4)	56.59 (185.66)	64.05 (210.14)

Each transducer with inherent charge amplifier was connected to an underground coaxial cable system which leads into the instrumentation building, approximately 600 feet from the test area. All signals were amplified by Dynamic 6457 units and recorded on a 14-track Sangamo Model 4700 tape recorder at 152 centimeters per second (60 ips), along with an initial timing signal from a break wire placed on the booster charge and one millisecond timing pulses. The nominal response (-3dB) for this recording system is 30 kHz. Data from channels 1, 2, 7 and 8 (i.e., the closest transducers) were simultaneously recorded at 305 centimeters per second (120 ips) on a Honeywell Model 96 tape recorder. Data from the magnetic tapes, read at 19.05 cm per second, was recorded on a Honeywell Model 1612 oscillograph operated at 101.6 cm per second.

Photographic coverage was restricted to one test for each configuration, see Figure 3. Motion picture coverage included a Hycam Model 41.004 camera operated at 1500-4000 frames per second (fps) and one Mitchell camera operated at 24 fps. One Hulcher Model 40, 70-mm sequencing still camera, was operated at 20 pictures per second. Fiducial markers in the field of view with 3.05 meter spacing aided in determination of fireball diameter. Standard meteorological data was recorded for each test.

## RESULTS

### DATA ANALYSIS

Peak blast overpressure, time of arrival and scaled positive impulse information was obtained in direct analog form from the oscillograph records. After exclusion of poor results that could be attributed to instrumentation malfunction, impingement of fragments on the transducer elements or improper calibration, average values for peak pressure and scaled positive impulse were calculated for each weight and scaled distance.

The average peak pressures were compared directly with standard reference curves for hemispherical TNT surface blasts (Reference 1) to derive TNT equivalency ( $E_p$ ) as a percentage by weight based on equivalent side-on blast pressure at equal distances from the charge:

$$E_p = 100 \left[ \frac{W_{TNT}}{W_{M10}} \right]_{\text{constant pressure and distance}} = 100 \left[ \frac{Z_{M10}^3}{Z_{TNT}^3} \right]_{\text{constant pressure}} \quad (1)$$

where  $W$  is the weight of explosive,  $Z$  is scaled distance,  $P$  is the peak blast pressure and the subscripts refer to the explosive material.

Calculations of TNT impulse equivalency were based on the analytical method of McKown and McIntyre (Reference 2). Thus the impulse equivalency,  $E_I$ , is given in terms of measured parameters by

$$E_I = 0.0163 Z_{M10}^{1.42} I_{M10}^{1.58} \quad (2)$$

where  $I$  is the measured impulse in (kPa) (msec)/kg<sup>1/3</sup> at scaled distance  $Z$  in meters/kg<sup>1/3</sup>.

An analysis of contributions to the measured peak pressure and impulse showed that the weight of booster material used for these tests is insignificant. To a first approximation, the TNT equivalencies of the C4 booster and the M10 propellant were assumed equal, i. e., the actual explosive charge weight is the sum of the booster and test material. Neglect of the booster then corresponds



to an error of 2 percent in weight of explosive and a maximum error of 1 percent in scaled distance. Uncertainties of this magnitude produce corresponding errors in pressure and impulse that are considerably below the standard deviation of reference tables (Reference 1) and are an order of magnitude less than experimental errors in normal blast measurements. The same conclusion is obtained for any reasonable assumption concerning the actual equivalency of the booster material; the contribution may be totally neglected for booster weights on the order of 2 percent, test material equivalencies in the range of 50 percent to 300 percent, and scaled distances in the range from 1 to 16  $\text{m}/\text{kg}^{1/3}$ .

## TEST RESULTS

Data sheets for all tests with pertinent measured parameters are given in Appendix A. Selected pretest and posttest still photographs are given in Appendix B. Test numbers shown are for local reference only and provide access to original range data files.

Average pressure, scaled positive impulse, and time of arrival data, with standard deviations, are summarized by test configuration in Tables 2 thru 6 and Figures 4 thru 9. Percent TNT equivalencies for all charge weights are shown in Figure 10 as functions of scaled distance. Composite equivalency curves based upon similar ratios of height to weight ( $h/w$ ) are shown in Figure 11 and are reproduced in the Summary section of this report. Fireball duration and diameter as measured from the high speed motion pictures are given in Table 8.

## DISCUSSION

The plots of peak pressure versus scaled distance (Figures 4 thru 8) from the orthorhombic configuration show the same general trend that has been observed in recent TNT equivalency determinations on other explosive and propellant materials. Compared to corresponding TNT hemispherical surface burst, the observed pressures are greater at the near field values ( $Z \leq 6 \text{ m}/\text{kg}^{1/3}$ ) and less than the standard for far field values ( $Z > 6 \text{ m}/\text{kg}^{1/3}$ ). Impulse versus distance data shows similar tendencies, although impulse equivalencies were significantly higher than the pressure equivalencies at the near field values. Pressure and impulse data obtained from the 11.34, 22.78 and 45.5 kg charge masses in similar ratio  $h/w < 1$  are fit by a single curve. Similarly, data from the 45.4 and 65.8 kg with similar ratio  $h/w > 1$  also plot as a single curve. The composite data is shown in Tables 7 and 8 and Figures 9, 10 and 11. Essentially S-shaped TNT Equivalency curves were obtained by use of the mean data, see Figure 12.

Figure 13 is a graphical presentation of the deviation from cube root scaling using the M10 propellant data. A positive slope indicates that increasing charge masses at constant scaled distance results in an increase in pressure or impulse equivalency. Conversely, a negative slope is indicative of a decrease in pressure

or impulse equivalency for increased charge masses. Although a positive slope was obtained for side-on pressure and a negative slope was observed for scaled impulse, to within experimental error the data correlated with the standard TNT cube root scaling for all charge weights tested.

Fireball characteristics shown in Table 9 were obtained from the high speed motion pictures taken during a singular test at each charge weight. The fireball diameter and duration were compared to predictions from equations given by High (Reference 3):

$$D = 3.86 W^{0.320} ; T_D = 0.299 W^{0.320}$$

where D is the fireball diameter in meters, W is the weight of material in kilograms, and  $T_D$  is the duration in seconds.

The observed fireball diameters do not agree with predicted values except for the data from the 11.34 kg test, and there does not appear to be any general correlation in the data. The fireball durations are fit reasonably well if the constant is revised, i. e.,

$$T_D \approx 0.13 W^{0.320}$$

It is apparent that variations due to container construction, geometry, and ullage prohibit a detailed analysis with the limited data from these tests.

The 24 frame per second motion pictures were used only for test documentation and for verification of the fireball information obtained from the high speed film. The Hulcher camera provided excellent documentary photographs of the reaction characteristics, as shown in Appendix B.

## CONCLUSIONS

1. The pressure and impulse TNT equivalency of M10, Type 2, SP 0.018 propellant in four orthorhombic configurations varies with scaled distance and is greater than 100 percent at near field values ( $Z < 3\text{m}/\text{kg}^{1/3}$ ) and less than 100 percent at far field values ( $Z \geq 3\text{m}/\text{kg}^{1/3}$ ).
2. Within experimental error, the pressures and impulses from the orthorhombic and conveyor bucket configurations (11.34 kg, 22.68 kg, 45.36 kg, 65.77 kg) scaled according to the cube root of charge weight.
3. The blast output from M10 propellant is dependent upon the configuration in which it is detonated.

## REFERENCES

1. C. N. Kingery, "Air Blast Parameters Versus Distances for Hemispherical TNT Surface Bursts," BRL Report No. 1344, September 1966.
2. G. L. McKown, F. L. McIntyre, Preliminary Report; "TNT Equivalency of Composition A-5," June 1976.
3. R. W. High, Annals of New York Academy of Science 152 I, Pages 441-451 (1968).

Table 2. Summary of Test Results, 11.34 kg Charges

R, meters (ft.)	Z, m/kg <sup>1/3</sup> (ft/lb <sup>1/3</sup> )	Time of Arrival (ms)	Peak Pressure kPa (psi)	Scaled Positive Impulse kPa.ms/kg <sup>1/3</sup> (psi.ms/lb <sup>1/3</sup> )	Pressure TNT Equivalency Percent	Impulse TNT Equivalency Percent
2.67 (8.77)	1.19 (3.00)	0.99 $\pm$ 0.10	1138 $\pm$ 119 (165. $\pm$ 17.3)	593.9 $\pm$ 106.8 (66.18 $\pm$ 11.9)	155 $\pm$ 15	385 $\pm$ 100
3.61 (11.84)	1.61 (4.05)	1.74 $\pm$ 0.15	578. $\pm$ 68 (83.9 $\pm$ 9.8)	336.2 $\pm$ 52 (37.47 $\pm$ 5.8)	140 $\pm$ 22	300 $\pm$ 35
4.80 (15.7)	2.13 (5.38)	3.17 $\pm$ 0.22	245.2 $\pm$ 40 (35.57 $\pm$ 5.71)	156.2 $\pm$ 25.1 (17.41 $\pm$ 2.8)	95 $\pm$ 24	120 $\pm$ 35
8.02 (26.3)	3.57 (9.0)	9.22 $\pm$ 0.53	71.7 $\pm$ 6.8 (10.4 $\pm$ 0.99)	56.7 $\pm$ 10.8 (6.32 $\pm$ 1.2)	70 $\pm$ 10	60 $\pm$ 15
16.04 (52.6)	7.14 (18.0)	29.61 $\pm$ 0.73	19.2 $\pm$ 2 (2.78 $\pm$ 0.33)	35.4 $\pm$ 4.0 (3.95 $\pm$ 0.45)	60 $\pm$ 14	75 $\pm$ 8
35.7 (117.0)	15.87 (40.0)	83.93 $\pm$ 1.03	6.6 $\pm$ 0.4 (0.95 $\pm$ 0.06)	17.9 $\pm$ 1.9 (2.00 $\pm$ 0.21)	75 $\pm$ 7	85 $\pm$ 15

Table 3. Summary of Test Results, 22.68 kg Charges

R, meters (ft.)	Z, m/kg <sup>1/3</sup> (ft/lb <sup>1/3</sup> )	Time of Arrival (ms)	Peak Pressure kPa (psig)	Scaled Positive Impulse kPa.ms/kg <sup>1/3</sup> (psi.ms/lb <sup>1/3</sup> )	Pressure TNT Equivalency Percent	Impulse TNT Equivalency Percent
3.37 (11.1)	1.19 (3.0)	1.25 $\pm$ 0.09	1146 $\pm$ 128 (163.3 $\pm$ 18.6)	492.3 $\pm$ 66.4 (54.86 $\pm$ 7.4)	145 $\pm$ 20	345 $\pm$ 70
4.55 (14.9)	1.61 (4.05)	2.09 $\pm$ 0.18	634 $\pm$ 42 (91.9 $\pm$ 6.05)	296.9 $\pm$ 70.0 (33.09 $\pm$ 7.8)	155 $\pm$ 15	250 $\pm$ 95
6.04 (19.8)	2.13 (5.38)	3.76 $\pm$ 0.12	337 $\pm$ 92 (48.86 $\pm$ 13.4)	141.4 $\pm$ 17.9 (15.76 $\pm$ 2.0)	150 $\pm$ 60	115 $\pm$ 40
10.1 (33.2)	3.57 (9.0)	10.16 $\pm$ 0.17	79.3 $\pm$ 4.5 (11.50 $\pm$ 0.65)	57.7 $\pm$ 8.1 (6.43 $\pm$ 0.9)	85 $\pm$ 5	60 $\pm$ 7
20.2 (66.3)	7.14 (18.0)	37.43 $\pm$ 0.19	18.3 $\pm$ 1.0 (2.66 $\pm$ 0.15)	34.6 $\pm$ 2.7 (3.86 $\pm$ 0.3)	60 $\pm$ 5	75 $\pm$ 8
44.9 (147.4)	15.87 (40.0)	106.21 $\pm$ 0.46	7.7 $\pm$ 1.7 (1.11 $\pm$ 0.24)	17.0 $\pm$ 3.6 (1.90 $\pm$ 0.4)	90 $\pm$ 25	80 $\pm$ 25

Table 4. Summary of Test Results 45.4 Charges With a Ratio h/w < 1

R, meters (ft.)	Z, m/kg <sup>1/3</sup> (ft/lb <sup>1/3</sup> )	Time of Arrival (ms)	Peak Pressure kPa (psig)	Scaled Positive Impulse kPa·ms/kg <sup>1/3</sup> (psi·ms/lb <sup>1/3</sup> )	Pressure TNT Equivalency Percent	Impulse TNT Equivalency Percent
4.24 (13.92)	1.19 (3.0)	1.66±0.20	1066.6±152 (154.7±22.1)	416.7±90 (46.44±10)	135±30	255±70
5.73 (18.80)	1.61 (4.05)	2.81±0.30	619±32 (89.7±4.7)	293.3±72 (32.69±8)	150±10	230±70
7.61 (24.97)	2.13 (5.38)	4.40±0.45	367±83 (53.2±12.0)	167.8±27 (18.7±3.0)	165±45	125±25
12.73 (41.77)	3.57 (9.0)	14.67±0.75	71.7±7.1 (10.4±1.00)	58.9±2.2 (6.56±0.24)	75±10	65±5
25.47 (83.55)	7.14 (18.0)	47.17±1.62	18.8±3.4 (2.72±0.5)	28.5±2.1 (3.18±0.23)	60±15	55±10
56.59 (185.66)	15.87 (40.0)	134.04±2.18	7.10±1.6 (1.03±0.23)	10.1±2.7 (1.12±0.3)	95±20	55±15

Table 5. Summary of Test Results 45.4 kg Charge in the M-25 Stainless Steel Vented Container With a Ratio h/w > 1

R, meters (ft.)	Z, m/kg <sup>1/3</sup> (ft/lb <sup>1/3</sup> )	Time of Arrival (ms)	Peak Pressure kPa (psig)	Scaled Positive Impulse kPa·ms/kg <sup>1/3</sup> (psi·ms/lb <sup>1/3</sup> )	Pressure TNT Equivalency Percent	Impulse TNT Equivalency Percent
4.24 (13.92)	1.19 (3.0)	1.43±0.11	1350±59 (195.8±8.5)	353±73 (39.3±8.1)	185±15	215±70
5.73 (18.80)	1.61 (4.05)	2.45±0.13	827±155 (120±22.5)	269±63 (30±7)	200±55	175±25
7.61 (24.97)	2.13 (5.38)	4.37±0.5	333±70 (48.3±10.1)	186±22 (20.7±2.5)	150±45	185±35
12.73 (41.77)	3.57 (9.0)	12.94±1.72	78.6±8.3 (11.4±1.2)	52±9.9 (5.8±1.1)	85±15	45±25
25.47 (83.55)	7.14 (18.0)	45±1.74	21.7±2.8 (3.15±0.4)	26.5±1.8 (2.95±0.2)	80±20	45±10
56.59 (185.66)	15.87 (40.0)	132.9±2.1	7.1±0.8 (1.03±0.12)	6.3±1.8 (.7±0.2)	60±20	15±5

Table 6. Summary of Test Results 65.77 kg Charges

R, meters (ft)	Z, m/kg <sup>1/3</sup> (ft/lbs <sup>1/3</sup> )	Time of Arrival (ms)	Peak Pressure kPa (psig)	Scaled Positive Impulse kPa.ms/kg <sup>1/3</sup> (psi.ms/lbs <sup>1/3</sup> )	Pressure TNT Equivalency Percent	Impulse TNT Equivalency Percent
4.80 (15.76)	1.19 (3.0)	1.75 <sub>-0.15</sub>	934 <sub>+113</sub> (135.5 <sub>+16.4</sub> )	340.6 <sub>+119</sub> (37.96 <sub>+13.3</sub> )	110 <sub>+20</sub>	180 <sub>+48</sub>
6.49 (21.28)	1.61 (4.05)	2.72 <sub>+0.36</sub>	587 <sub>+85</sub> (85.1 <sub>+12.3</sub> )	368 <sub>+130</sub> (41.02 <sub>+14.5</sub> )	130 <sub>+15</sub>	350 <sub>+49</sub>
8.61 (28.26)	2.13 (5.38)	4.62 <sub>+0.67</sub>	312 <sub>+90</sub> (45.2 <sub>+13.04</sub> )	161.3 <sub>+33</sub> (17.98 <sub>+3.7</sub> )	160 <sub>+40</sub>	150 <sub>+25</sub>
14.41 (47.28)	3.57 (9.0)	13.97 <sub>+1.64</sub>	90.4 <sub>+14.2</sub> (13.11 <sub>+2.06</sub> )	68. <sub>+15</sub> (7.58 <sub>+1.7</sub> )	105 <sub>+20</sub>	75 <sub>+28</sub>
28.82 (94.55)	7.14 (18.0)	50.5 <sub>+1.97</sub>	21.1 <sub>+1</sub> (3.06 <sub>+0.13</sub> )	29.8 <sub>+5.5</sub> (3.32 <sub>+0.61</sub> )	75 <sub>+5</sub>	60 <sub>+16</sub>
64.05 (210.14)	15.87 (40.0)	147.8 <sub>+1.98</sub>	8.1 <sub>+1.37</sub> (1.17 <sub>+0.2</sub> )	11 <sub>+3.6</sub> (1.23 <sub>+0.4</sub> )	110 <sub>+30</sub>	40 <sub>+12</sub>

Table 7. Summary of Test Results of 11.34, 22.68 and 45.36 kg Charge Weight Combined with Ratio h/w < 1

Scaled Distance Z, m/kg <sup>1/3</sup> (ft/lbs <sup>1/3</sup> )	Scaled Time of Arrival ms/kg <sup>1/3</sup>	Peak Pressure kPa (psig)	Scaled Positive Impulse kPa.ms/kg <sup>1/3</sup> (psi.ms/lbs <sup>1/3</sup> )	Pressure TNT Equivalency Percent	Impulse TNT Equivalency Percent
1.19 (3.0)	0.44 <sub>+0.03</sub>	1027 <sub>+83</sub> (149 <sub>+12</sub> )	501 <sub>+72</sub> (55.8 <sub>+8</sub> )	113 <sub>+10</sub>	326 <sub>+39</sub>
1.61 (4.05)	0.76 <sub>+0.04</sub>	613 <sub>+48</sub> (88.9 <sub>+7</sub> )	318 <sub>+36</sub> (35.4 <sub>+4</sub> )	143 <sub>+14</sub>	279 <sub>+42</sub>
2.13 (5.38)	1.32 <sub>+0.07</sub>	299 <sub>+62</sub> (43.4 <sub>+9</sub> )	149 <sub>+18</sub> (16.6 <sub>+2</sub> )	138 <sub>+31</sub>	128 <sub>+22</sub>
3.57 (9.0)	3.84 <sub>+0.18</sub>	74 <sub>+7</sub> (10.7 <sub>+1</sub> )	59.2 <sub>+4.5</sub> (6.6 <sub>+0.5</sub> )	87 <sub>+13</sub>	64 <sub>+6</sub>
7.14 (18.0)	13.17 <sub>+0.28</sub>	19 <sub>+2</sub> (2.7 <sub>+0.3</sub> )	32.3 <sub>+6.3</sub> (3.6 <sub>+0.7</sub> )	62 <sub>+11</sub>	71 <sub>+8</sub>
15.87 (40.0)	37.47 <sub>+0.45</sub>	7.6 <sub>+1.4</sub> (1.1 <sub>+0.2</sub> )	16.6 <sub>+2.7</sub> (1.85 <sub>+0.3</sub> )	93 <sub>+46</sub>	77 <sub>+15</sub>

Table 8. Summary of Test Results of 45.4 and 65.8 kg Charge Weights Combined With Ratio h/w < 1

Scaled Distance <sup>1/3</sup> Z, m/kg <sup>1/3</sup> (ft/lbs <sup>1/3</sup> )	Scaled Time of Arrival ms/kg <sup>1/3</sup>	Peak Pressure kPa (psig)	Scaled Positive Impulse kPa·ms/kg <sup>1/3</sup> (psi·ms/lbs <sup>1/3</sup> )	Pressure TNT Equivalency Percent	Impulse TNT Equivalency Percent
1.19 (3.0)	0.43 <sub>-0.03</sub>	1218 <sub>+193</sub> (176.6 <sub>+28</sub> )	347 <sub>+54</sub> (38.7 <sub>+6</sub> )	163 <sub>+36</sub>	211 <sub>+43</sub>
1.61 (4.05)	0.68 <sub>+0.05</sub>	579 <sub>+83</sub> (83.9 <sub>+12</sub> )	347 <sub>+54</sub> (38.7 <sub>+6</sub> )	140 <sub>+29</sub>	329 <sub>+51</sub>
2.13 (5.38)	1.19 <sub>+0.11</sub>	325 <sub>+90</sub> (47.1 <sub>+13</sub> )	169 <sub>+27</sub> (18.8 <sub>+3</sub> )	151 <sub>+49</sub>	164 <sub>+29</sub>
3.57 (9)	3.28 <sub>+1.00</sub>	81.4 <sub>+9</sub> (11.8 <sub>+1.3</sub> )	62 <sub>+9</sub> (6.9 <sub>+1</sub> )	89 <sub>+17</sub>	79 <sub>+16</sub>
7.14 (18)	12.57 <sub>+0.30</sub>	20.9 <sub>+0.8</sub> (3.03 <sub>+0.11</sub> )	28.7 <sub>+3.6</sub> (3.2 <sub>+0.4</sub> )	74 <sub>+6</sub>	57 <sub>+10</sub>
15.87 (40)	36.72 <sub>+0.38</sub>	8.5 <sub>+1.7</sub> (1.24 <sub>+0.24</sub> )	9.2 <sub>+1.8</sub> (1.03 <sub>+0.2</sub> )	140 <sub>+55</sub>	30 <sub>+10</sub>

Table 9. Fireball Duration and Diameter

Charge Weight, kg (lb)	Maximum Fireball Diameter, meters (ft)	Fireball Duration, ms
11.34 (25)	9.14 (30)	300
22.68 (50)	18.29 (60)	300
45.4 (100)	19.81 (65)	550
65.77 (145)	30.48 (100)	550

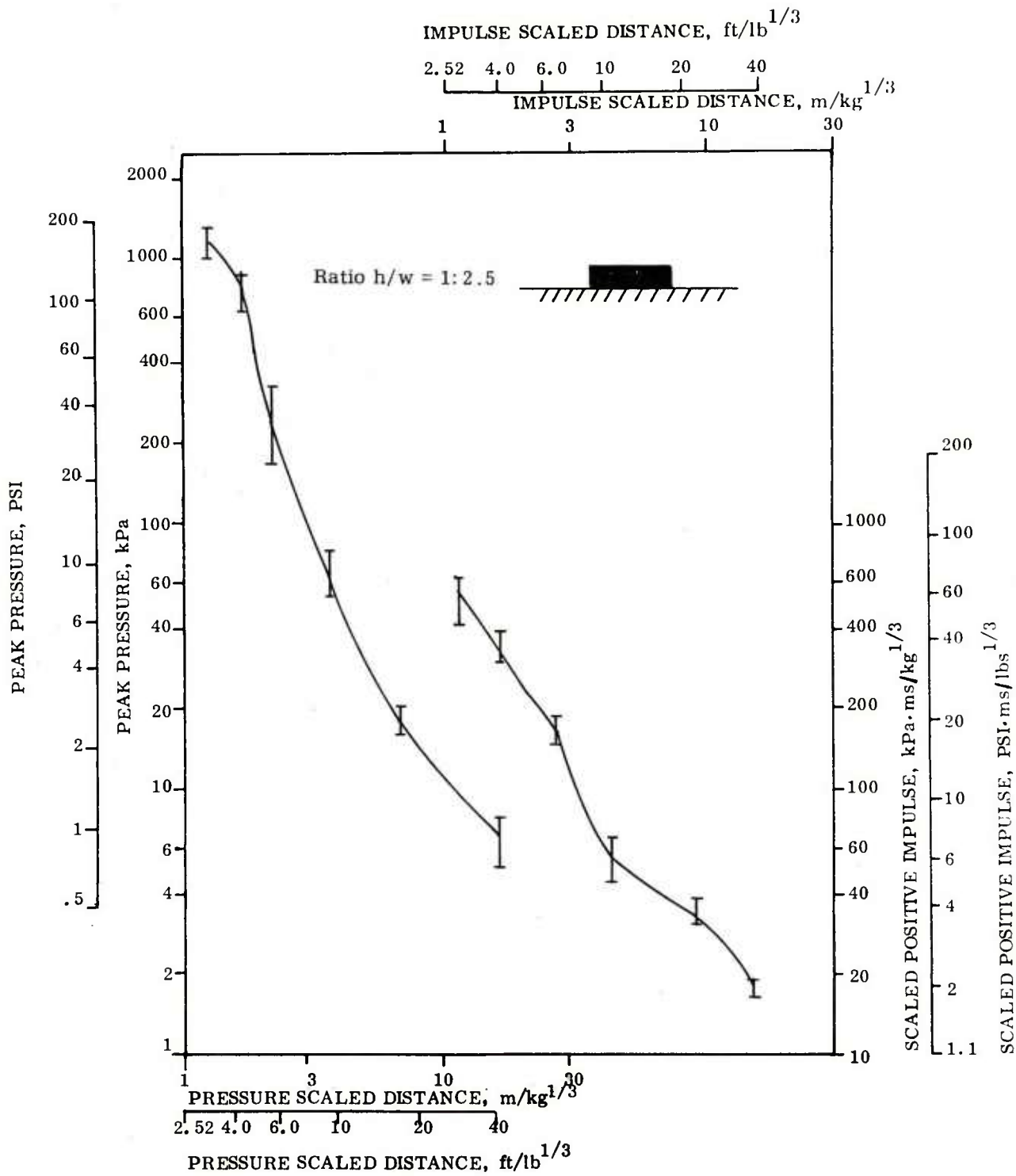

Figure 4. Pressure and Impulse vs. Scaled Distance, 11.34 kg Charges



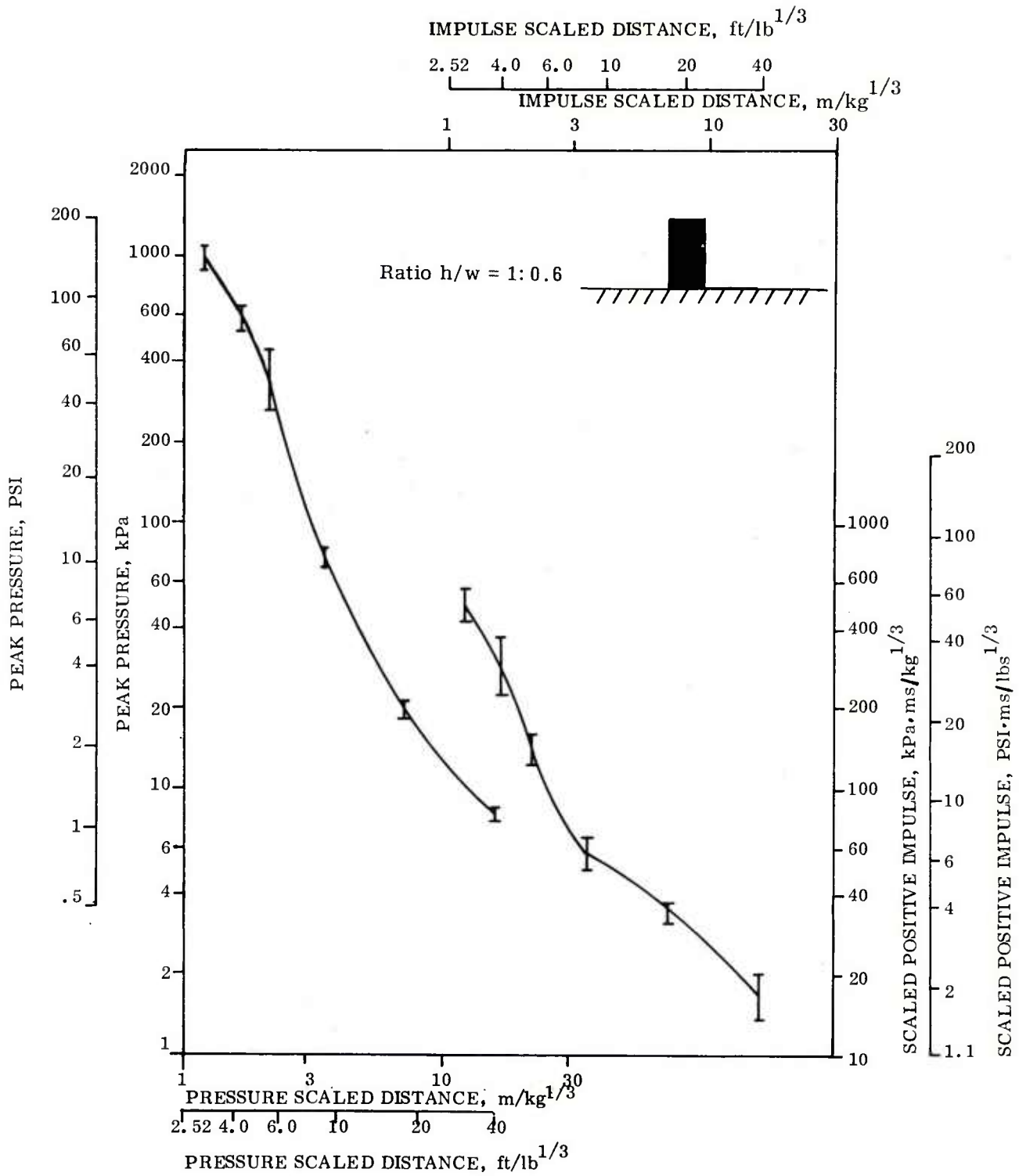

Figure 5. Pressure and Impulse vs. Scaled Distance, 22.68 kg Charges

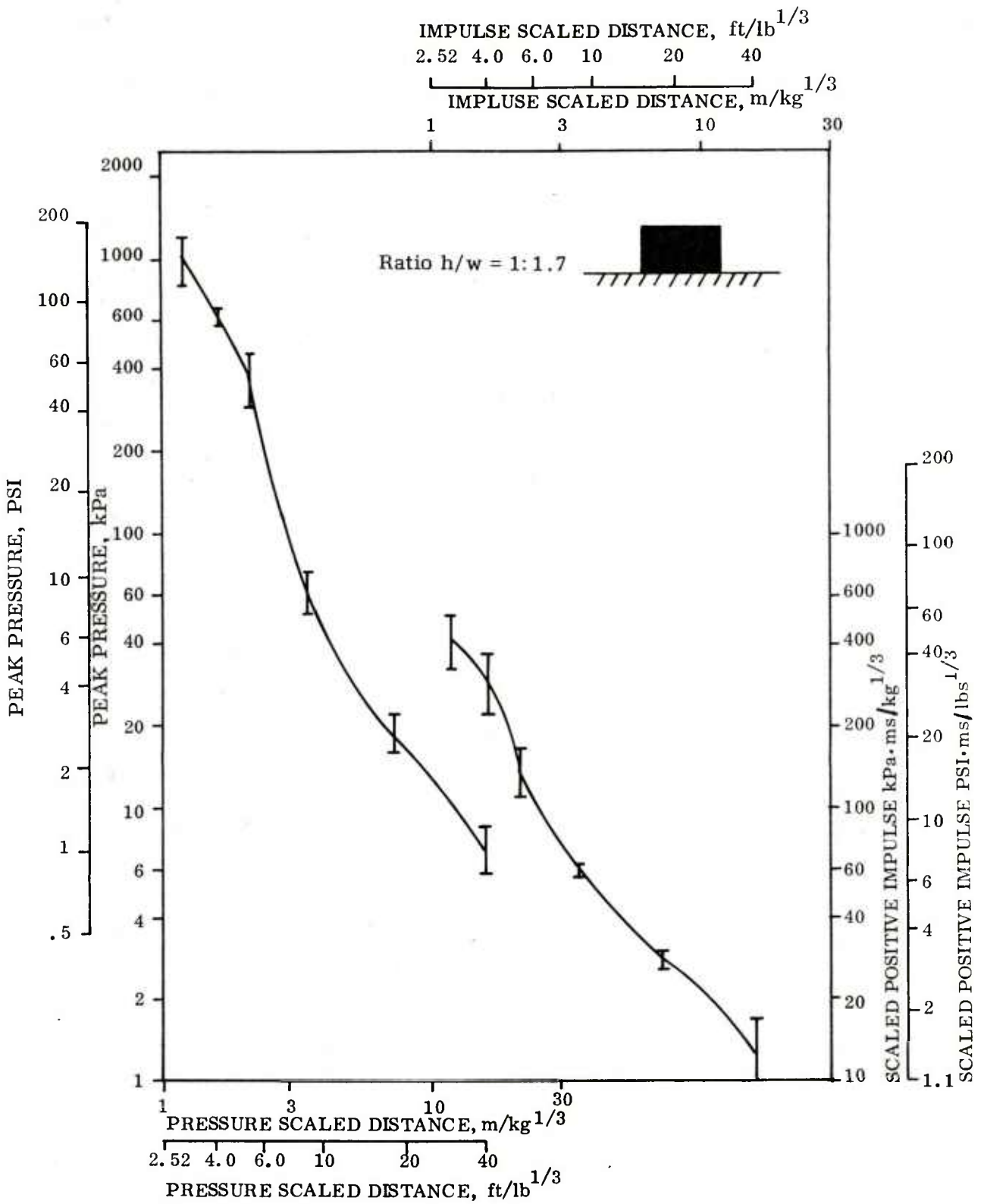

Figure 6. Pressure and Impulse vs. Scaled Distance, 45.4 kg Charges

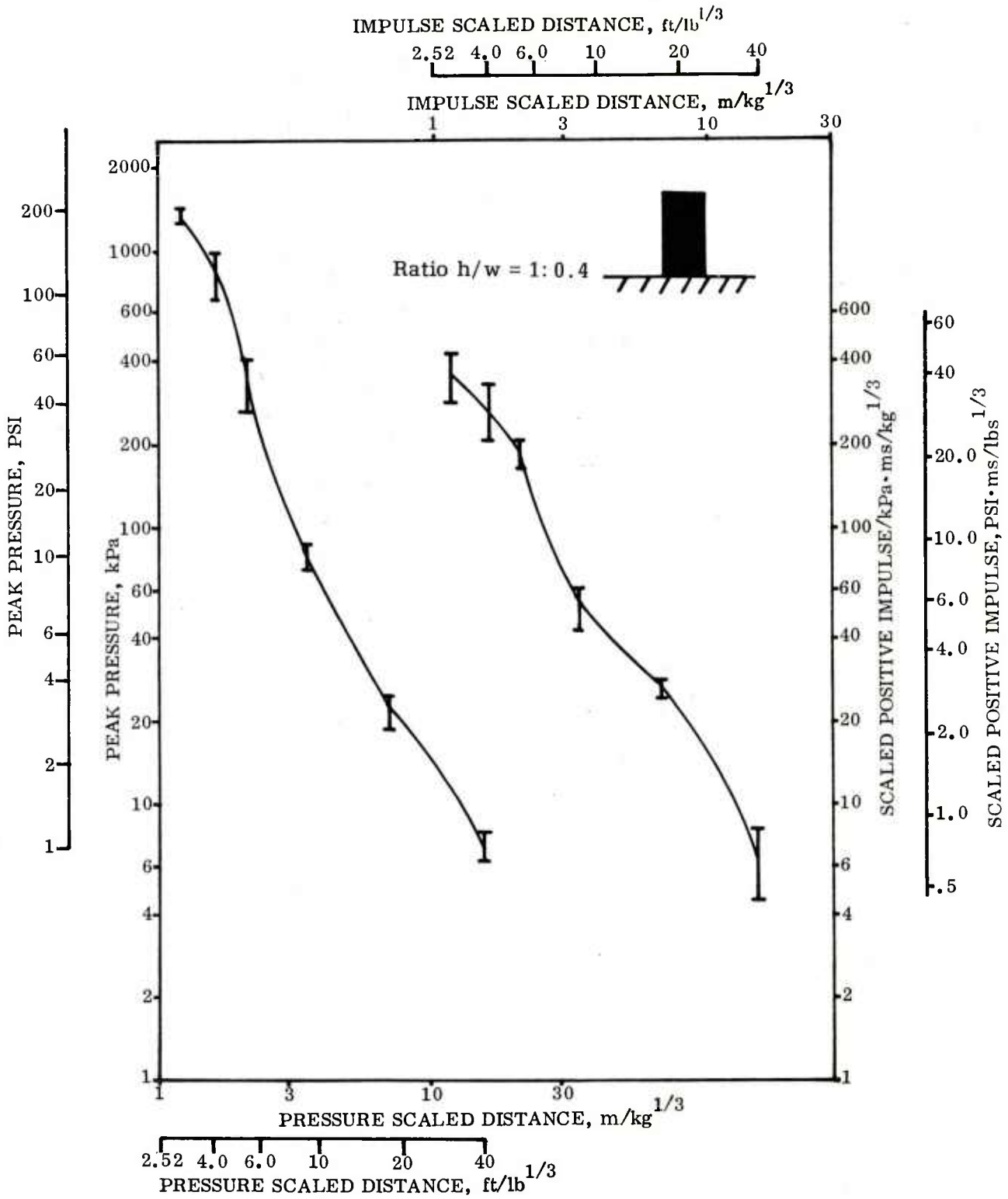

Figure 7. Pressure and Impulse vs. Scaled Distance, 45.4 kg Charge M-25 Stainless Steel Container Ratio  $h/w = 1:0.4$ .



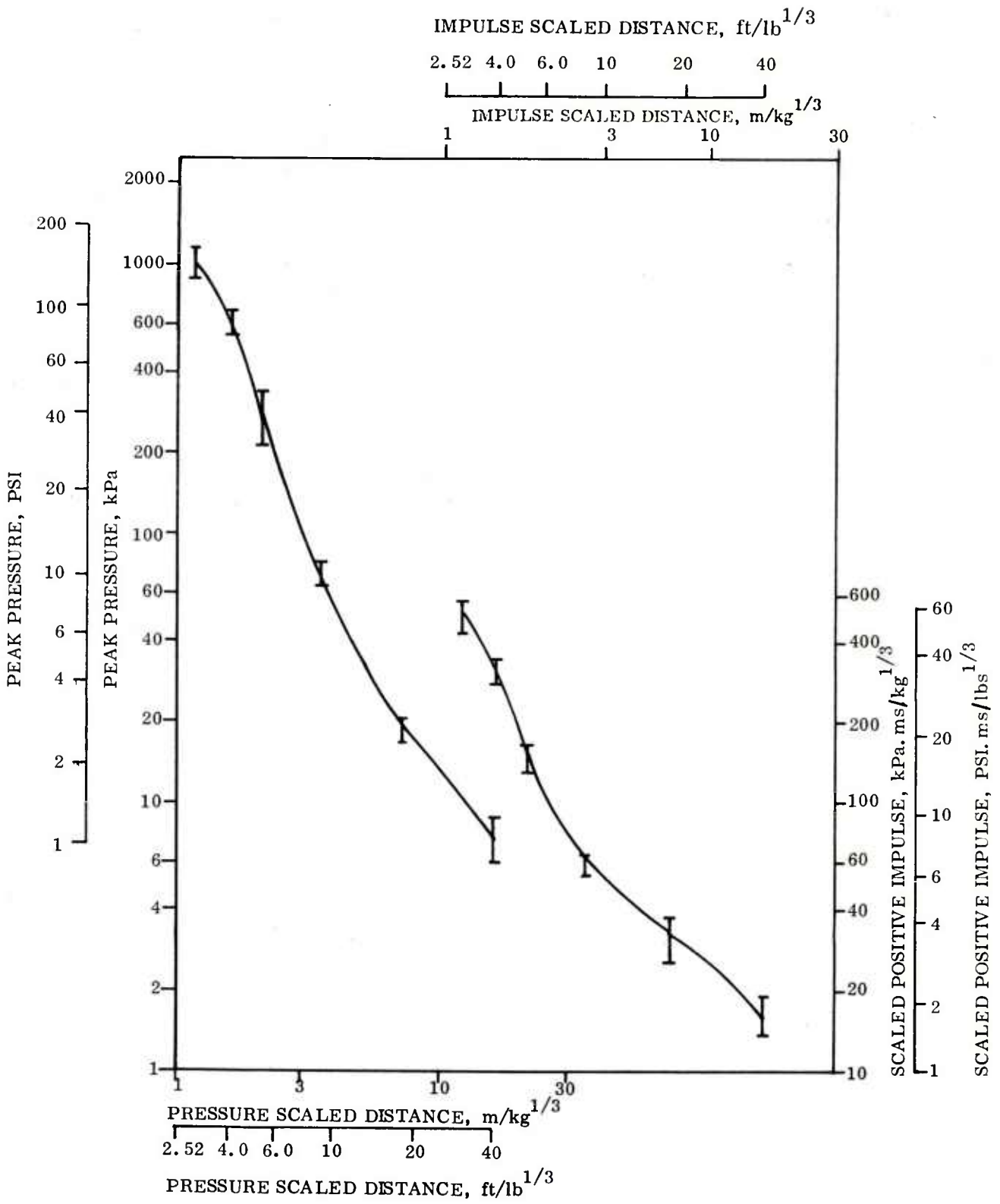

Figure 9. Pressure and Impulse vs. Scaled Distance for Combined Weights of 11.34, 22.68 and 45.4 kg Charges with a Ratio  $h/w < 1$

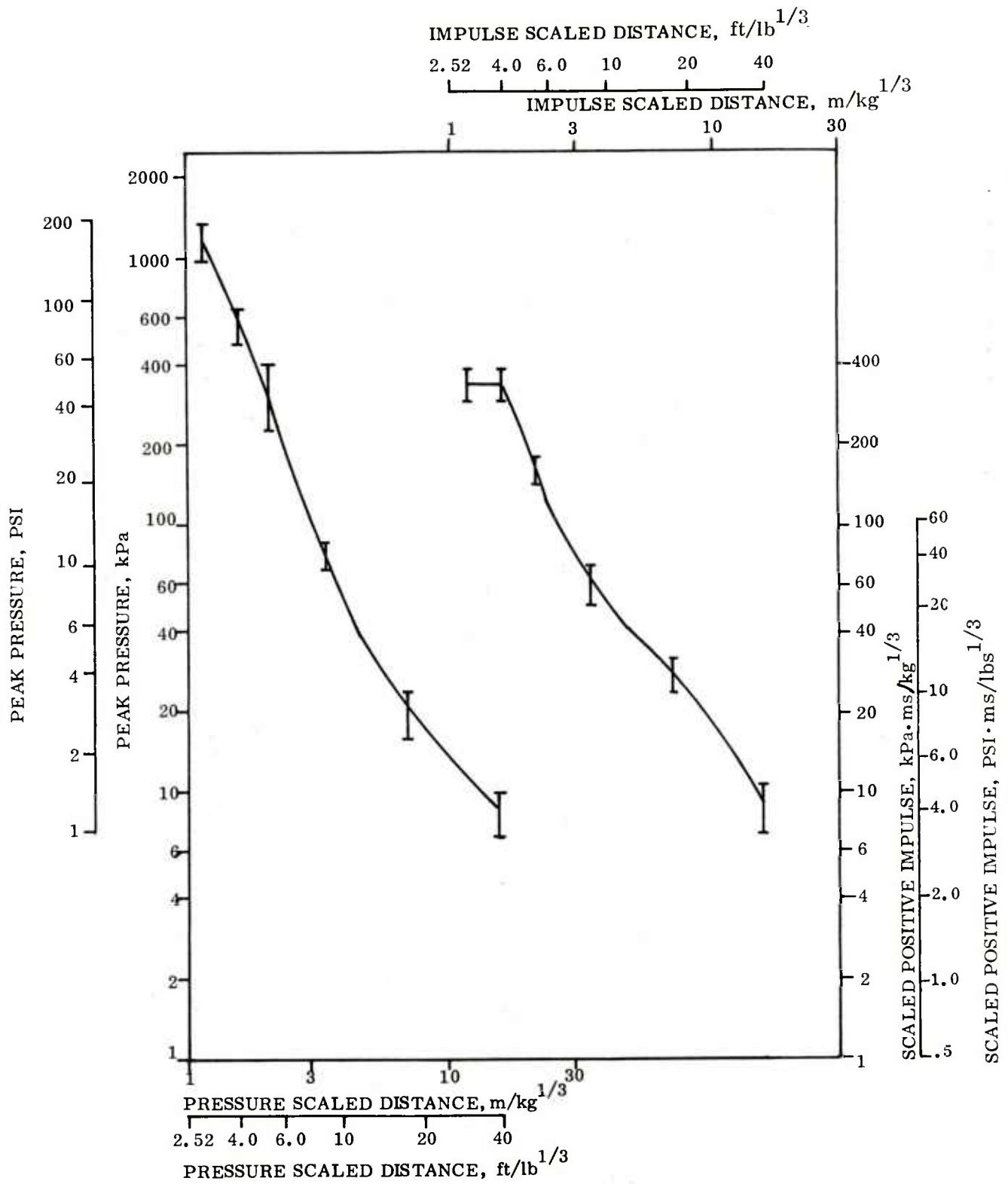

Figure 10. Pressure and Impulse vs. Scaled Distance for Combined Weights of 45.4, 65.8 kg Charges with a Ratio  $h/w > 1$

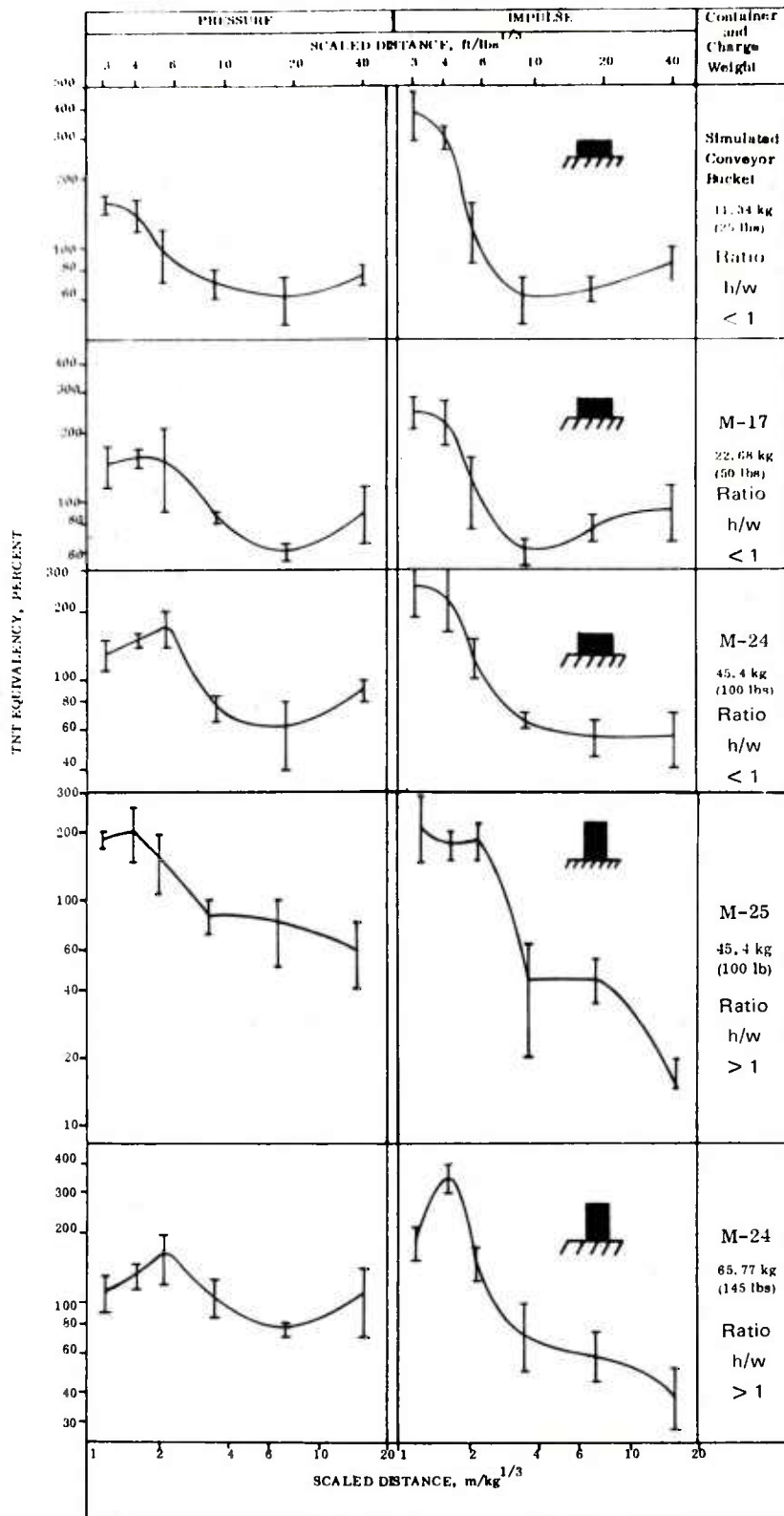

Figure 11. Pressure and Impulse Equivalencies

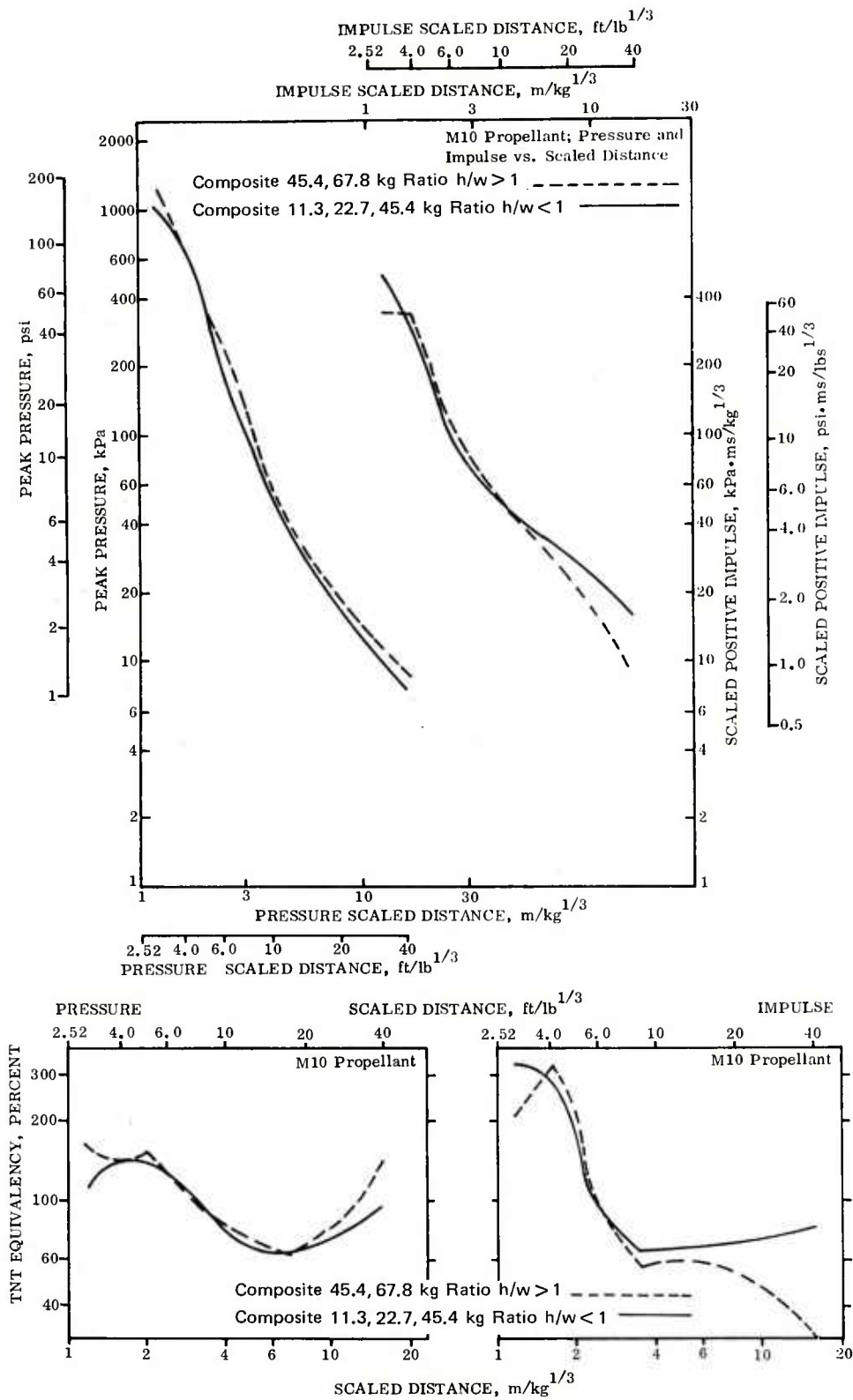
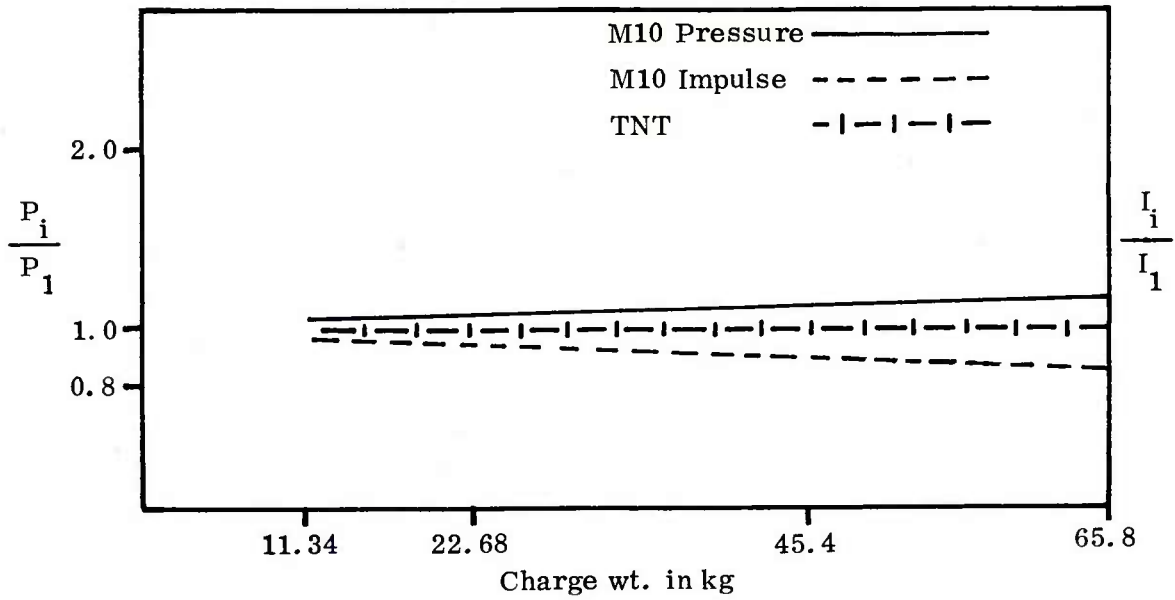

Figure 12. Composite TNT Equivalency of M10 Propellant





Where  $P_1$  = Side on Pressure, 11.34 kg Charge Weight

$P_i$  = Side on Pressure,  $i^{\text{th}}$  Charge Weight

Figure 13. Deviation From Cube-root Scaling of M10 Propellant.

APPENDIX A

FIELD DATA SHEETS

Test Number 15-6-01 A1

TEST TITLE Explosive Equivalency Testing DATE 4/8/76  
 TEST SAMPLE M10 Propellant; M-24 Shipping Container TIME 1324 Hrs.  
 SAMPLE WEIGHT 100 lbs/45.36 kg TEMP. 79°F/26.1°C  
 IGNITION SOURCE J-2 Engineer's Special Blasting Cap HUMIDITY 50%  
 BOOSTER WT. 1 lb./ .45 kg Comp C-4, 1% of Charge Wt. BAR. PRES. 29.86  
 TEST NUMBER 15-6-01 A1 WIND DIR. 300°  
 CONTRACT NO. NAS8-27750 WIND VEL. 9 Knots

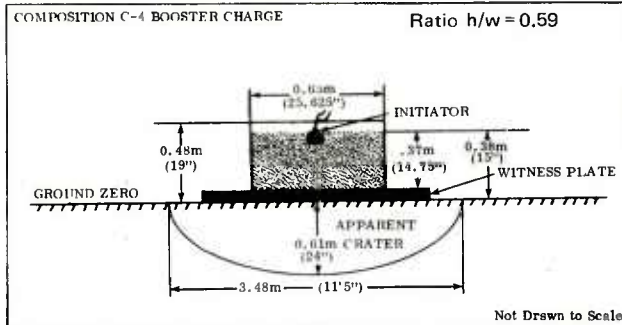

FIELD EVALUATION

No data channels 3 and 12  
Complete detonation. No unburned propellant was found.  
Box oriented with ends North and South  
Acoustics data was measured.

A <sub>1</sub> Test 45.4 kg M10 Propellant					
Channel No.	Distance Meters (ft.)	Peak Pressure kPa (psig)	Scaled Positive Impulse kPa.msec/kg <sup>1/3</sup> (psi.msec/lbs <sup>1/3</sup> )	Time of Arrival (msec)	Remarks
1	4.24 (13.92)	965.3 (140)	305 (33.99)	1.6	
7		965.3 (140)	360 (40.12)	1.6	
2	5.73 (18.80)	578.2 (84)	499.6 (55.68)	2.8	
8		867.7 (126)	329.5 (36.72)	2.8	
3	7.61 (24.97)	-	-	3.8	No data
9		475.7 (69)	160.7 (17.91)	4.0	
4	12.73 (41.77)	62.1 (9)	61 (6.80)	14.1	
10		96.5 (14)	65.2 (7.27)	15.7	
5	25.47 (83.55)	12.4 (1.8)	29.97 (3.34)	47.0	
11		20.7 (3.0)	27 (3.01)	44.8	
6	56.57 (185.66)	10.3 (1.5)	14.4 (1.60)	134.4	
12		-	-	-	No data

Test Number 15-6-01 A2

TEST TITLE Explosive Equivalency Testing DATE 4/8/76  
 TEST SAMPLE M10 Propellant; M-24 Shipping Container TIME 1457 Hrs.  
 SAMPLE WEIGHT 100 lbs/45.36 kg TEMP. 82°F/27.8°C  
 IGNITION SOURCE J-2 Engineer's Special Blasting Cap HUMIDITY 34%  
 BOOSTER WT. 1.5 lbs/0.68 kg Comp C-4, 1.5% of Charge Wt. BAR. PRES. 29.81  
 TEST NUMBER 15-6-01 A2 WIND DIR. 30°  
 CONTRACT NO. NAS8-27750 WIND VEL. 5 Knots

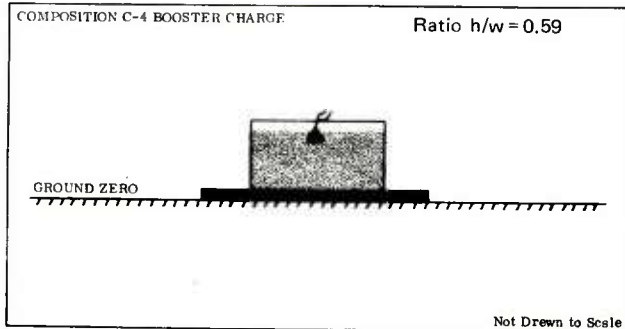

FIELD EVALUATION

Complete detonation  
Box ends East & West  
Crater Dimension 0.64 meter deep by 3.36 meter wide  
Acoustics data was measured

A <sub>2</sub> Test 45.4 kg M10 Propellant					
Channel No.	Distance Meters (ft.)	Peak Pressure kPa (psig)	Scaled Positive Impulse kPa.msec/kg <sup>1/3</sup> (psi.msec/lbs <sup>1/3</sup> )	Time of Arrival (msec)	Remarks
1	4.24 (13.92)	1310 (190)	416.8 (46.45)	2.0	
7		1034.2 (150)	475.7 (53.01)	1.8	
2	5.73 (18.80)	578.2 (84)	280.2 (31.23)	2.8	
8		861.9 (96)	275.8 (30.74)	2.8	
3	7.61 (24.97)	227.5 (33)	36.6 (4.08)	4.7	
9		413.7 (60)	163.9 (18.27)	4.8	
4	12.73 (41.77)	51.7 (7.5)	59 (6.58)	13.4	
10		72.4 (10.5)	59.3 (6.61)	15.0	
5	25.47 (83.55)	14.5 (2.1)	23.8 (2.65)	45.7	
11		20.7 (3.0)	29.3 (3.27)	48.3	
6	56.59 (185.60)	6.9 (1.0)	13.3 (1.48)	131.3	
12		13.8 (2.0)	10.7 (1.19)	135.8	

## Test Number 15-6-01 A3

TEST TITLE Explosive Equivalency Testing DATE 4/9/76  
 TEST SAMPLE M10 Propellant; M-24 Shipping Container TIME 1255 Hrs.  
 SAMPLE WEIGHT 100 lbs/45.36 kg TEMP. 74°F/23.3°C  
 IGNITION SOURCE J-2 Engineer's Special Blasting Cap HUMIDITY 24%  
 BOOSTER WT. 1.0 lbs/.45 Kg; Comp C-4 BAR. PRES. 30.05  
1% of Charge Wt. WIND DIR. 300°  
 TEST NUMBER 15-6-01 A3 WIND VEL. 11 Knots  
 CONTRACT NO. NAS8-27750

A <sub>3</sub> Test 45.4 kg M10 Propellant					
Channel No.	Distance Meters (ft.)	Peak Pressure kPa (psig)	Scaled Positive Impulse kPa.msec/kg <sup>1/3</sup> (psi.msec/lbs <sup>1/3</sup> )	Time of Arrival (msec)	Remarks
1	4.24 (13.92)	-	-	2.0	Bad data ringing
7		827.4 (120)	353.0 (39.34)	1.6	
2	5.73 (18.80)	599.8 (87)	362.6 (40.41)	2.8	
8		661.9 (96)	142.9 (15.93)	2.5	
3	7.61 (24.97)	289.6 (42)	-	4.4	No peak
9		496.4 (72)	189.9 (18.93)	4.2	
4	12.73 (41.77)	79.3 (11.5)	62.5 (6.97)	14.2	
10		48.3 (7.0)	57.2 (6.37)	14.8	
5	25.47 (83.55)	17.4 (2.52)	28.3 (3.15)	45.9	
11		13.8 (2.0)	31.9 (3.55)	48.6	
6	56.59 (185.66)	6.2 (0.9)	15.8 (1.76)	132.1	
12		6.2 (0.9)	8.8 (0.98)	136.6	

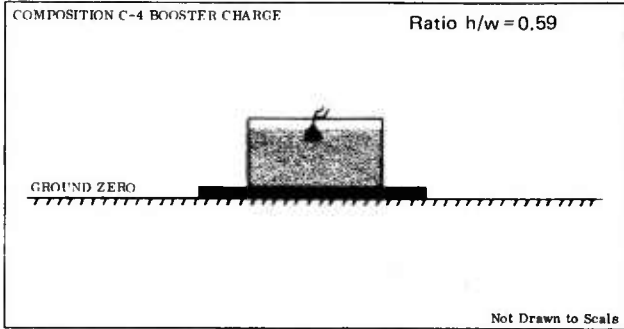

FIELD EVALUATION  
 Complete detonation. No unburned propellant. A 1% booster weight is to be utilized throughout the remainder of the test period.  
 Box ends East and West  
 Acoustics data was measured  
 Crater dimension 0.76 meters deep by 4.08 meters wide.

## Test Number 15-6-01 A4

TEST TITLE Explosive Equivalency Testing DATE 4/9/76  
 TEST SAMPLE M10 Propellant; M-24 Shipping Container TIME 1408 Hrs.  
 SAMPLE WEIGHT 100 lbs/45.36 kg TEMP. 76°F/24.4°C  
 IGNITION SOURCE J-2 Engineer's Special Blasting Cap HUMIDITY 21%  
 BOOSTER WT. 1.0 lbs/.45 Kg; Comp C-4 BAR. PRES. 30.03  
1% of Charge Wt. WIND DIR. 340°  
 TEST NUMBER 15-6-01 A4 WIND VEL. 11 Knots  
 CONTRACT NO. NAS8-27750

A <sub>4</sub> Test 45.4 kg M10 Propellant					
Channel No.	Distance Meters (ft.)	Peak Pressure kPa (psig)	Scaled Positive Impulse kPa.msec/kg <sup>1/3</sup> (psi.msec/lbs <sup>1/3</sup> )	Time of Arrival (msec)	Remarks
1	4.24 (13.92)	--	502.2 (55.96)	1.7	Ringing impulse estimated
7		965.3 (140)	360 (40.12)	1.4	
2	5.73 (18.80)	620.5 (90)	-	2.8	Hit 3 Txdr limited after peak Before return to baseline
8		529.5 (76.8)	176 (19.61)	2.5	
3	7.61 (24.97)	282.7 (41)	-	4.9	Poor peak
9		372.3 (54)	153.9 (17.15)	4.8	
4	12.73 (41.77)	75.8 (11)	58.1 (6.47)	14.3	
10		48.3 (7)	43 (4.79)	15.3	
5	25.47 (83.55)	19.3 (2.8)	24.9 (2.78)	46.3	
11		15.2 (2.2)	32.6 (3.63)	48.7	
8	56.59 (185.66)	8.9 (1.0)	18.4 (2.05)	131.8	
12		13.8 (2.0)	7.4 (0.82)	136.0	

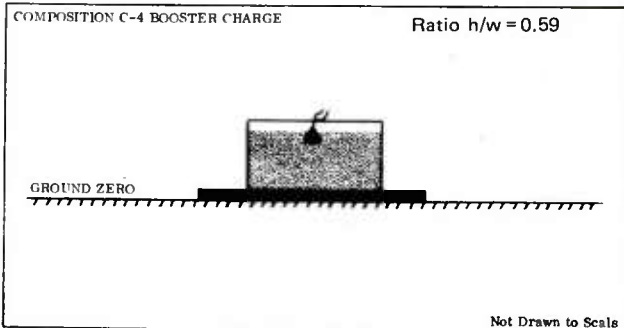

FIELD EVALUATION  
 Complete detonation  
 Photographic coverage. Hycam 1500 (fps) Hulcher (20 fps) Documentary (24 fps)  
 Box ends East and West  
 Crater dimension 0.81 meters deep by 4.1 meters wide  
 Acoustics data was measured.

## Test Number 15-6-01 A5

TEST TITLE	Explosive Equivalency Testing	DATE	4/9/76
TEST SAMPLE	M10 Propellant; M-24 Shipping Container	TIME	1505 Hrs.
SAMPLE WEIGHT	100 lbs / 45.36 kg	TEMP.	77°F/25°C
IGNITION SOURCE	J-2 Engineer's Special Blasting Cap	HUMIDITY	22%
BOOSTER WT.	1 lbs / .45 kg; Comp C-1 1% of Charge Wt.	BAR. PRES.	30.02
TEST NUMBER	15-6-01 A5	WIND DIR.	360°
CONTRACT NO.	NAS8-27750	WIND VEL.	10 Knots

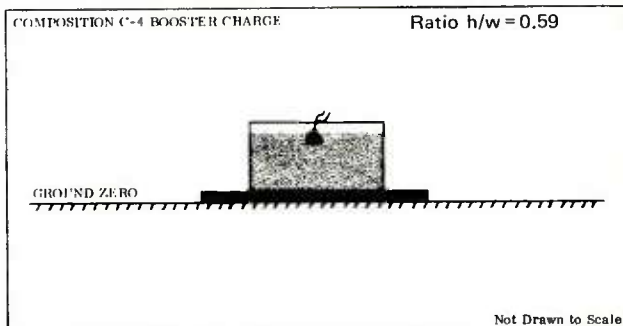

**FIELD EVALUATION**

Box ends orientated East and West

---

Acoustics data was measured

---

Crater dimension 0.65 meters by 4.05 meters wide.

---



---



---

A <sub>5</sub> Test 45.4 kg M10 Propellant					
Channel No.	Distance Meters (ft.)	Peak Pressure kPa (psig)	Scaled Positive Impulse kPa·msec/kg <sup>1/3</sup> (psi·msec/lbs)	Time of Arrival (msec)	Remarks
1	4.24 (13.92)	-	-	1.6	Ringng. Unable to determine peak. Txdr was replaced.
7		965.3 (140)	586.8 (65.39)	1.5	
2	5.73 (18.80)	820.5 (90)	331.2 (36.91)	3.6	
8		824.7 (90.6)	126.6 (14.11)	2.7	
3	7.61 (24.97)	-	-	3.7	Bad txdr.
9		330.9 (48)	131.8 (14.69)	4.7	
4	12.73 (41.77)	68.9 (10)	58 (6.46)	14.2	
10		62.1 (9)	55.8 (6.22)	15.7	
5	25.47 (83.55)	20.7 (3)	23.6 (2.63)	46.3	
11		16.5 (2.4)	34 (3.79)	49.9	
6	56.59 (185.66)	6.2 (0.9)	15.6 (1.74)	132.2	
12		13.8 (2.0)	10.7 (1.19)	136.2	

## Test Number 15-6-01 A6

TEST TITLE	Explosive Equivalency Test	DATE	8/7/76
TEST SAMPLE	M10 Propellant; M25 Shipping Container	TIME	1305
SAMPLE WEIGHT	100 lbs / 45.4 kg	TEMP.	85°F/29.4°C
IGNITION SOURCE	J2 Engineer's Special Blasting Cap	HUMIDITY	31%
BOOSTER WT.	1.5 lbs / 0.68 kg; Comp 4 1 1/2% of Charge Wt.	BAR. PRES.	30.01
TEST NUMBER	24-6-01A6	WIND DIR.	30%
CONTRACT NO.	NAS8-27750	WIND VEL.	12 Knots

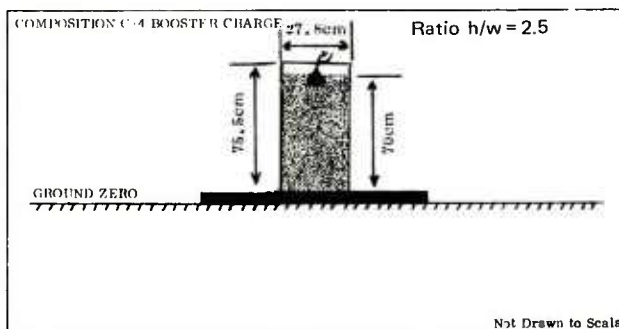

**FIELD EVALUATION**

Motion Picture Coverage

---

Acoustic Measurements

---

Complete detonation

---

Crater Dimension .45 meters deep by 3.02 meters wide

---



---

A <sub>6</sub> Test 45.4 kg M- M10 Propellant					
Channel No.	Distance Meters (ft.)	Peak Pressure kPa (psig)	Scaled Positive Impulse kPa·msec/kg <sup>1/3</sup> (psi·msec/lbs)	Time of Arrival (msec)	Remarks
1	4.24 (13.92)	1379 (200)	342.8 (38.20)	1.35	
7		1379 (200)	286.3 (31.91)	1.4	
2	5.73 (18.80)	827.4 (120)	2.9 (24.41)	2.35	
8		827.4 (120)	252.3 (28.12)	2.6	Limited
3	7.61 (24.97)	293 (42.5)	173.1 (19.29)	3.55	Limited
9		413.7 (60)	212.1 (23.64)	4.6	
4	12.73 (41.71)	88.9 (10.0)	44.5 (4.96)	11.5	
10		84.1 (12.2)	58.2 (6.49)	14.3	
5	25.47 (83.55)	24.1 (3.5)	21.9 (2.44)	43.8	
11		18.8 (2.7)	34.0 (3.79)	46.8	Double Peak
8	56.59 (185.66)	10.3 (1.5)	4.3 (0.48)	130.4	
12		5.5 (0.8)	7.9 (0.88)	134.2	

## Test Number 15-6-01 A7

TEST TITLE	Explosive Equivalency Test	DATE	6/7/76
TEST SAMPLE	M10 Propellant; M's Shipping Container	TIME	1418
SAMPLE WEIGHT	5. kg (100 lbs)	TEMP.	85°F/29.4°C
IGNITION SOURCE	J-2 Engineer's Special Blasting Cap	HUMIDITY	30
BOOSTER WT.	1.5 lbs/0.68 kg; Comp C-4 1 1/2% of Charge Wt.	BAR. PRES.	30.00
TEST NUMBER	24-6-01A <sub>7</sub>	WIND DIR.	70°
CONTRACT NO.	NAS8-27750	WIND VEL.	4 Knots

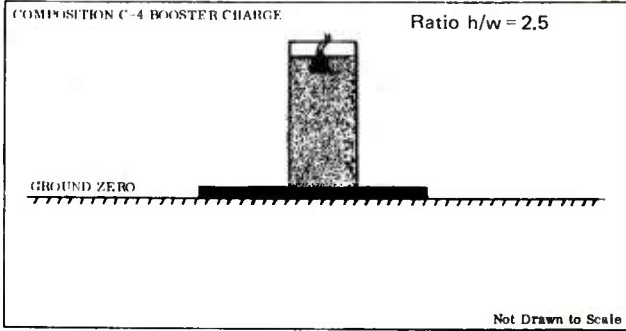

**FIELD EVALUATION**

Acoustics Measurements

Complete Detonation

Crater Dimension .47 meters deep by 3.32 meters wide

A <sub>7</sub> Test 45.4 kg M10 Propellant					
Channel No.	Distance Meters (ft.)	Peak Pressure kPa (psig)	Scaled Positive Impulse kPa·msec/kg <sup>1/3</sup> (psi·msec/lbs <sup>1/3</sup> )	Time of Arrival (msec)	Remarks
1	4.24	1378	628.5	1.6	
	(13.91)	(200)	(70.04)		
7		1261.7	429.5	1.5	
		(183)	(47.86)		
2	5.73	517.1	-	2.8	Limited (did not return to baseline) Rad
	(18.80)	(75)			
8		827.4	311.1	2.4	Limited
		(120)	(34.67)		
3	7.61	293	173.1	4.7	
	(24.97)	(42.5)	(19.29)		
9		586.1	255.6	3.8	Limited
		(85)	(23.48)		
4	12.73	46	32	14.55	
	(41.71)	(6.67)	(3.57)		
10		82.7	72.1	11.4	
		(12.0)	(8.04)		
5	25.47	24.1	26.2	47.0	Double Peak
	(83.55)	(3.5)	(2.92)		
11		18.8	27.2	44.0	Double Peak
		(2.73)	(3.03)		
6	56.59	6.9	4.4	134.0	
	(185.66)	(1.0)	(0.49)		
12		5.5	7.0	130.0	
		(0.8)	(0.78)		

## Test Number 15-6-02 B1

TEST TITLE	Explosive Equivalency Testing	DATE	4/10/78
TEST SAMPLE	M10 Propellant; M-17 Shipping Container	TIME	1030 Hrs.
SAMPLE WEIGHT	50 lbs/22.68 kg	TEMP.	75°F/23.8°C
IGNITION SOURCE	J-2 Engineer's Special Blasting Cap	HUMIDITY	28%
BOOSTER WT.	0.5 lbs/.23 kg; Comp C-4 1% Charge Wt.	BAR. PRES.	30.17
TEST NUMBER	15-6-02 B <sub>1</sub>	WIND DIR.	150°
CONTRACT NO.	NAS8-27750	WIND VEL.	4 Knots

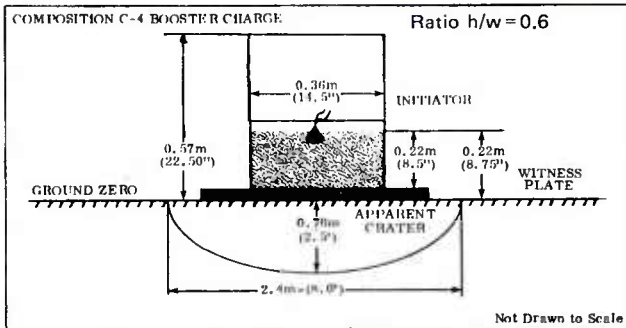

**FIELD EVALUATION**

Complete reaction. No unburned propellant

All instrumentation functioned

Crater dimension 8.76 meters deep by 2.4 meters wide

Box orientated North and South

B <sub>1</sub> Test 22.68 kg M10 Propellant					
Channel No.	Distance Meters (ft.)	Peak Pressure kPa (psig)	Scaled Positive Impulse kPa·msec/kg <sup>1/3</sup> (psi·msec/lbs <sup>1/3</sup> )	Time of Arrival (msec)	Remarks
1	3.37	1241.1	383.53	1.2	
	(11.05)	(180)	(42.74)		
7		1034.2	485.74	1.0	
		(150)	(54.13)		
2	4.55	861.9	436.74	1.9	
	(14.92)	(86)	(48.67)		
8		579.2	301.42	1.6	
		(84)	(33.59)		
3	6.04	289.6	46.68	3.4	Bad data
	(19.82)	(42)	(5.20)		
9		393	174.89	2.8	
		(57)	(19.49)		
4	10.11	82.7	60.12	9.0	
	(33.16)	(12)	(6.70)		
10		82.7	37.42	8.8	
		(12)	(4.17)		
5	20.21	17.2	36.61	28.3	
	(66.31)	(2.5)	(4.08)		
11		18.8	31.88	29.7	
		(2.7)	(3.59)		
6	44.92	9.0	19.65	83.3	
	(147.36)	(1.3)	(2.19)		
12		6.9	12.92	84.1	
		(1.0)	(1.44)		

## Test Number 15-6-02 B2

TEST TITLE	Explosive Equivalency Testing	DATE	4/10/76
TEST SAMPLE	M10 Propellant; M-17 Shipping Container	TIME	1130 Hrs.
SAMPLE WEIGHT	50 lbs/22.68 kg	TEMP.	75°F/23.8°C
IGNITION SOURCE	J-2 Engineer's Special Blasting Cap	HUMIDITY	26%
BOOSTER WT.	1 lb./45 kg Comp C-4 2% of Charge Wt.	BAR. PRES.	30.17
TEST NUMBER	15-6-02 B2	WIND DIR.	195°
CONTRACT NO.	NAS8-27750	WIND VEL.	8 Knots

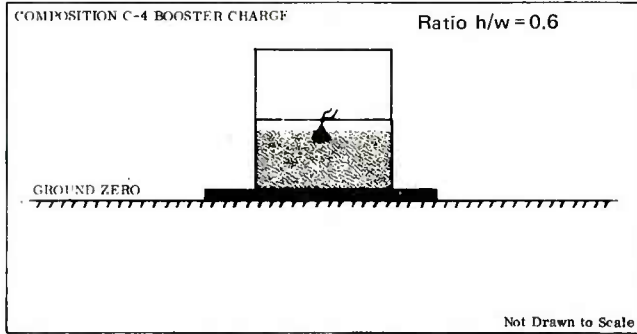

### FIELD EVALUATION

Complete reaction. No unburned propellant found. Will utilize 1 pound booster for the remainder of the tests. This choice was made based upon the witness plate rather than peak pressure.

Crater dimension 0.32 meter deep by 2.4 meters wide.

Box orientation North and South

B <sub>2</sub> Test 22.68 kg M10 Propellant					
Channel No.	Distance Meters (ft.)	Peak Pressure kPa (psig)	Scaled Positive Impulse kPa·msec/kg <sup>1/3</sup> (psi·msec/lbs <sup>1/3</sup> )	Time of Arrival (msec)	Remarks
1	3.37 (11.05)	1241.1 (180)	454.2 (50.61)	1.3	Ringing
7		1034.2 (150)	396.6 (44.20)	1.35	
2	4.55 (14.92)	620.5 (90)	219.5 (32.48)	2.2	
8		648.1 (94)	197.5 (22.01)	2.3	
3	6.04 (19.82)	248.2 (36)	154.3 (17.19)	4.0	
9		413.7 (60)	141.4 (15.76)	3.95	
4	10.11 (33.16)	68.9 (10)	57.6 (6.42)	10.4	
10		79.3 (11.5)	59.9 (6.68)	10.0	
5	20.21 (66.31)	20.7 (3.0)	35.3 (3.93)	37.6	Double peak
11		19.3 (2.8)	34.5 (3.84)	37.65	Double peak
6	44.92 (147.36)	10.3 (1.5)	18.6 (2.07)	106.5	Double peak
12		6.9 (1.0)	14.0 (1.56)	106.3	Double peak

## Test Number 15-6-02 B3

TEST TITLE	Explosive Equivalency Testing	DATE	4/10/76
TEST SAMPLE	M10 Propellant; M-17 Shipping Container	TIME	1250 Hrs.
SAMPLE WEIGHT	50 lbs/22.68 kg	TEMP.	76°F/24.4°C
IGNITION SOURCE	J-2 Engineer's Special Blasting Cap	HUMIDITY	27%
BOOSTER WT.	1 lb./45 kg, Comp C-4, 2% of Charge Wt.	BAR. PRES.	30.16
TEST NUMBER	15-6-02 B3	WIND DIR.	185°
CONTRACT NO.	NAS8-27750	WIND VEL.	8 Knots

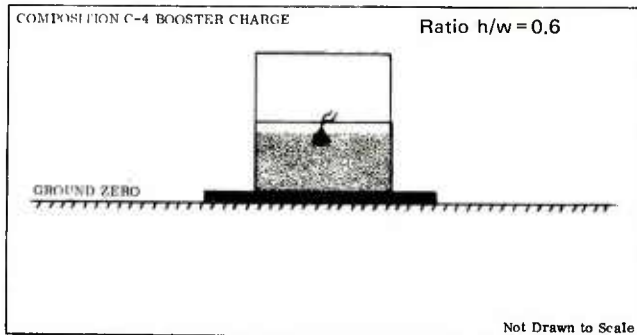

### FIELD EVALUATION

Complete reaction. No unburned propellant was found.

Crater dimension 0.31 meters deep by 2.4 meters wide.

Box orientation North and South

B <sub>3</sub> Test 22.68 kg M10 Propellant					
Channel No.	Distance Meters (ft.)	Peak Pressure kPa (psig)	Scaled Positive Impulse kPa·msec/kg <sup>1/3</sup> (psi·msec/lbs <sup>1/3</sup> )	Time of Arrival (msec)	Remarks
1	3.37 (11.05)	1241.1 (180)	514.7 (57.36)	1.3	Ringing
7		965.3 (140)	469.5 (52.32)	1.2	Limited
2	4.55 (14.92)	496.4 (72)	314.0 (34.99)	2.2	
8		661.9 (96)	279.8 (31.18)	2.2	
3	8.04 (19.82)	268.9 (39)	129.1 (14.39)	3.7	
9		441.3 (64)	123.5 (13.76)	3.7	
4	10.11 (33.16)	75.8 (11)	66.0 (7.35)	10.2	
10		79.3 (11.5)	58.1 (6.47)	10.2	
5	20.21 (66.31)	-	-	37.4	Limited ringing
11		19.3 (2.8)	32.5 (3.62)	37.4	Double peak
6	44.92 (147.36)	10.3 (1.5)	22.6 (2.52)	106.5	Double peak
12		6.9 (1.0)	17.1 (1.91)	105.5	Double peak

## Test Number 15-6-02 B4

TEST TITLE Explosive Equivalency Testing      DATE 4/10/76  
 TEST SAMPLE M10 Propellant; M-17 Shipping Container      TIME 1130 Hrs.  
 SAMPLE WEIGHT 50 lbs/22.68 kg      TEMP. 77°F/25°C  
 IGNITION SOURCE J-2 Engineer's Special Blasting Cap      HUMIDITY 28%  
 BOOSTER WT. 1 lb/.45 kg, Comp C-4, 2% of Charge Wt.      BAR. PRES. 30.15  
 TEST NUMBER 15-6-02 B4      WIND DIR. 180°  
 CONTRACT NO. NAS8-27750      WIND VEL. 11 Knots

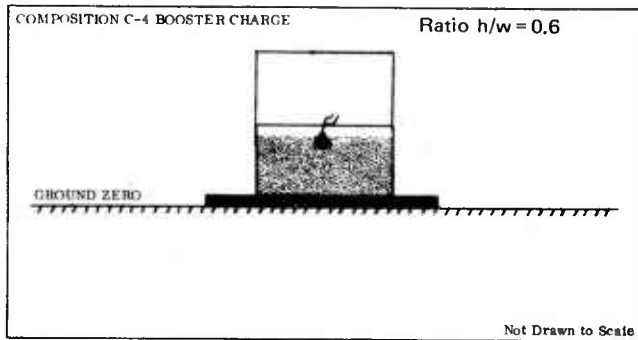

### FIELD EVALUATION

Complete reaction. No unburned propellant was found.  
 Crater dimension 0.31 meter deep by 2.46 meter wide.  
 Box orientation North and South.

B <sub>4</sub> Test 22.68 kg M10 Propellant					
Channel No.	Distance Meters (ft.)	Peak Pressure kPa (psig)	Scaled Positive Impulse kPa.msec/kg <sup>1/3</sup> (psi.msec/lbs <sup>1/3</sup> )	Time of Arrival (msec)	Remarks
1	3.37 (11.05)	-	-	1.15	Ringing
7	-	-	-	1.2	Limited
2	4.65 (14.92)	828.8 (91.2)	337.0 (37.56)	1.8	
8	-	661.9 (96)	307.2 (34.23)	2.25	
3	6.04 (19.82)	206.6 (30)	130.9 (14.59)	3.7	
9	-	434.4 (63)	137.1 (15.28)	3.7	
4	10.11 (33.16)	82.7 (12)	66 (7.35)	10	
10	-	68.3 (9.9)	57.2 (6.37)	9.9	
5	20.21 (66.31)	-	-	37.25	Bad channel
11	-	15.9 (2.3)	35.4 (3.95)	37.4	Double peak
6	44.92 (147.36)	7.6 (1.1)	21.0 (2.34)	106.54	Double peak
12	-	6.2 (0.9)	15.7 (1.75)	106.4	Double peak

## Test Number 16-6-01 B5

TEST TITLE Explosive Equivalency Testing      DATE 4/12/78  
 TEST SAMPLE M10 Propellant M-17 Shipping Container      TIME 1030 Hrs.  
 SAMPLE WEIGHT 50 lbs/22.68 kg      TEMP. 81°F/27.2°C  
 IGNITION SOURCE J-2 Engineer's Special Blasting Cap      HUMIDITY 48%  
 BOOSTER WT. 1 lb/.45 kg Comp C-4 2% of Charge Wt.      BAR. PRES. 30.20  
 TEST NUMBER 16-6-01 B5      WIND DIR. 310°  
 CONTRACT NO. NAS8-27750      WIND VEL. 9 Knots

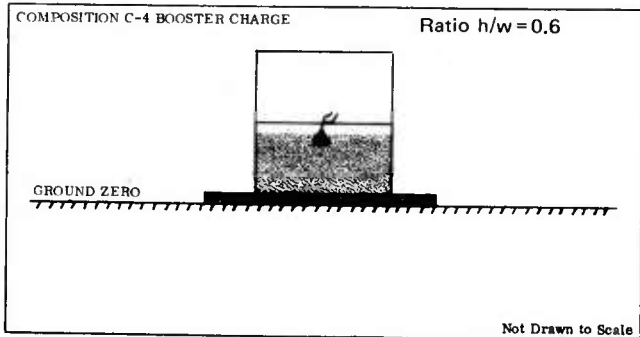

### FIELD EVALUATION

Complete detonation.  
 Box orientation North and South  
 Photographic coverage. Included Hycam 1500 (fps), Hulcher (20pps) and documentary (24fps)  
 Crater dimension 0.33 meter deep by 2.21 meter wide.

B <sub>5</sub> Test 22.68 kg M10 Propellant					
Channel No.	Distance Meters (ft.)	Peak Pressure kPa (psig)	Scaled Positive Impulse kPa.msec/kg <sup>1/3</sup> (psi.msec/lbs <sup>1/3</sup> )	Time of Arrival (msec)	Remarks
1	3.37 (11.05)	-	-	1.2	Ringing. Bad data.
7	-	758.4 (110)	567.2 (63.21)	1.3	Limited
2	4.55 (14.92)	537.8 (78)	401.1 (44.70)	2.05	Double peak
8	-	648.1 (84)	247.5 (27.58)	2.1	Double peak
3	8.04 (18.82)	-	-	3.75	(Hit 3) Bad signal
9	-	393 (57)	155.4 (17.32)	3.7	Double peak
4	10.11 (33.16)	81.4 (11.8)	57.3 (6.39)	10.2	
10	-	60.7 (11.7)	53.8 (5.99)	10.4	
5	20.21 (66.31)	17.2 (2.5)	33.5 (3.73)	37.25	Double peak
11	-	20.7 (3.0)	38.0 (4.35)	37.7	Double peak
6	44.92 (147.36)	8.8 (1.0)	17.2 (1.92)	105.7	Double peak
12	-	5.5 (0.8)	12.5 (1.39)	106.4	

## Test Number 16-6-02 C1

TEST TITLE	Explosive Equivalency Testing	DATE	4/13/76
TEST SAMPLE	M10 Propellant; M-24 Shipping Container	TIME	1245 Hrs.
SAMPLE WEIGHT	145 lbs/65.77 kg	TEMP.	82°F/27.8°C
IGNITION SOURCE	J-2 Engineer's Special Blasting Cap	HUMIDITY	49%
BOOSTER WT.	1.5 lbs/0.68 kg, Comp C-4 1% of Charge Wt.	BAR. PRES.	30.12
TEST NUMBER	16-6-02 C1	WIND DIR.	160°
CONTRACT NO.	NAS8-27750	WIND VEL.	7 Knots

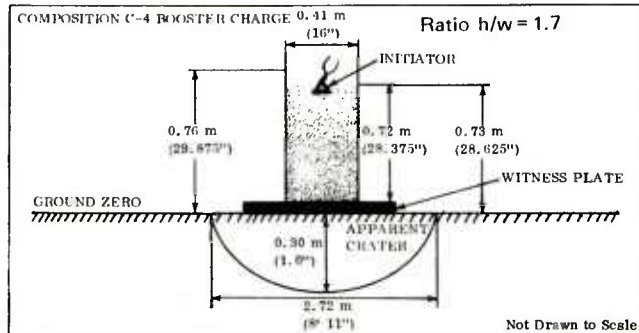

**FIELD EVALUATION**

Box orientation North and South

Complete detonation

Photographic coverage included Ilycam (1500 fps) Hulcher (30pps) documentary (24fps)

Crater dimension 0.30 meter deep by 2.72 meter wide

C <sub>1</sub> Test 65.77 kg M10 Propellant					
Channel No.	Distance Meters (ft.)	Peak Pressure kPa (psig)	Scaled Positive Impulse kPa.msec/kg <sup>1/3</sup> (psl.msec/lbs <sup>1/3</sup> )	Time of Arrival (msec)	Remarks
1	4.8 (15.76)	-	-	1.6	Transducer was destroyed
7		689.5 (100)	370.6 (41.30)	1.8	
2	6.49 (21.28)	579.2 (84)	304.7 (33.96)	2.5	
8		488.1 (70.8)	401.5 (44.74)	2.8	
3	8.77 (28.76)	200.8 (30)	-	3.8	Peak failed to return to baseline
9		446.8 (64.8)	170.0 (18.95)	5.0	
4	14.41 (47.28)	106.2 (15.4)	92.8 (10.34)	12.0	
10		75.8 (11)	56.7 (6.32)	15.4	
5	28.82 (94.56)	20.0 (2.9)	21.5 (2.4)	48.55	
11		22.1 (3.2)	30.6 (3.41)	51.9	
6	64.05 (210.14)	7.9 (1.15)	14.0 (1.56)	145.25	
12		8.6 (1.25)	7.6 (0.85)	149.15	

## Test Number 16-6-02 C2

TEST TITLE	Explosive Equivalency Testing	DATE	4/13/76
TEST SAMPLE	M10 Propellants M-24 Shipping Container	TIME	1445 Hrs.
SAMPLE WEIGHT	145 lbs/65.77 kg	TEMP.	78°F/25.6°C
IGNITION SOURCE	J-2 Engineer's Special Blasting Cap	HUMIDITY	56%
BOOSTER WT.	2.5 lbs./1.13 kg Comp C-4 1.5 % of Charge Wt.	BAR. PRES.	30.11
TEST NUMBER	16-6-02 C2	WIND DIR.	195°
CONTRACT NO.	NAS8-27750	WIND VEL.	9 Knots

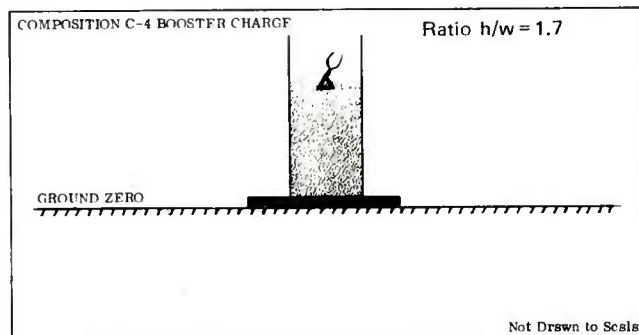

**FIELD EVALUATION**

Box orientation North and South

Crater dimension 0.33 meters deep by 2.72 meters wide

C <sub>2</sub> Test 65.77 kg M10 Propellant					
Channel No.	Distance Meters (ft.)	Peak Pressure kPa (psig)	Scaled Positive Impulse kPa.msec/kg <sup>1/3</sup> (psl.msec/lbs <sup>1/3</sup> )	Time of Arrival (msec)	Remarks
1	4.8 (15.76)	1379.0 (200)	317.8 (35.42)	1.7	
7		772.2 (112)	236.0 (26.30)	1.9	
2	6.49 (21.28)	537.8 (78)	389.0 (43.35)	2.7	
8		620.5 (90)	374.4 (41.72)	3.0	
3	8.77 (28.70)	268.9 (39)	148.6 (16.56)	4.5	
9		455.1 (66)	139.9 (15.59)	5.2	
4	14.41 (47.28)	106.2 (15.4)	79.9 (8.9)	14.0	
10		77.2 (11.2)	47.0 (5.24)	15.7	
5	28.82 (94.56)	22.8 (3.3)	23.7 (2.64)	49.7	
11		22.1 (3.2)	33.1 (3.69)	52.4	
6	64.05 (210.14)	10.3 (1.5)	4.8 (0.54)	147.4	
12		10.3 (1.5)	9.2 (1.02)	150	



### Test Number 16-6-02 C3

TEST TITLE Explosive Equivalency Testing DATE 4/14/76  
 TEST SAMPLE M10 Propellant; TIME 1300 Hrs.  
 SAMPLE WEIGHT 145 lbs/65.77 kg TEMP. 82°F/27.8°C  
 IGNITION SOURCE J-2 Engineer's Special Blasting Cap HUMIDITY 52%  
 BOOSTER WT. 1.5 lbs/0.68 kg Comp C-4; BAR. PRES. 30.13  
1% of Charge Wt. WIND DIR. 150°  
 TEST NUMBER 16-6-02 C3 WIND VEL. 13 Knots  
 CONTRACT NO. NAS8-27750

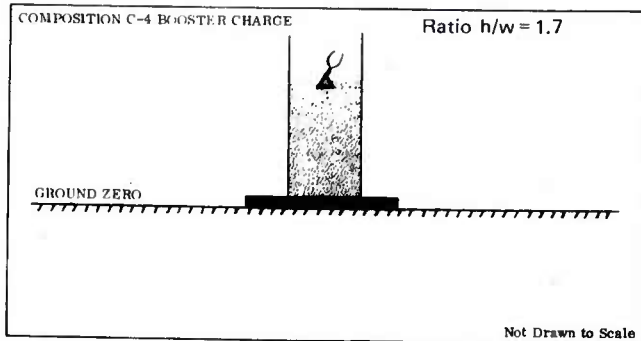

C <sub>3</sub> Test 85.77 kg M10 Propellant					
Channel No.	Distance Meters (ft.)	Peak Pressure kPa (psig)	Scaled Positive Impulse kPa.msec/kg <sup>1/3</sup> (psi.msec/lbs <sup>1/3</sup> )	Time of Arrival (msec)	Remarks
1	4.8 (15.76)	-	-	1.6	Txdr destroyed.
7		965.3 (140)	556.8 (62.05)	1.9	
2	8.49 (21.28)	524 (76)	436.6 (43.68)	2.1	
8		510.2 (74)	355.2 (39.58)	3.2	
3	8.77 (28.76)	228.9 (33.2)	243.0 (27.08)	3.6	
9		289.6 (42)	765.0 (18.39)	5.3	
4	14.41 (47.28)	96.5 (14)	50.3 (5.60)	12.1	
10		74.5 (10.8)	58.1 (6.48)	15.6	
5	28.82 (94.56)	20.7 (3)	18.5 (2.06)	48.6	
11		20.7 (3)	31.2 (3.48)	53.2	
6	84.05 (210.14)	6.2 (0.9)	15.1 (1.68)	145.9	
12		8.3 (1.2)	8.6 (0.98)	149.6	

**FIELD EVALUATION**

Box orientation North and South  
 Crater dimension 0.41 meters deep by 3.05 meters wide

### Test Number 16-6-02 C4

TEST TITLE Explosive Equivalency Testing DATE 4/14/78  
 TEST SAMPLE M10 Propellant; TIME 1405 Hrs.  
 SAMPLE WEIGHT 145 lbs/65.77 kg TEMP. 80°F/26.7°C  
 IGNITION SOURCE J-2 Engineer's Special Blasting Cap HUMIDITY 54%  
 BOOSTER WT. 1.5 lbs/0.68 kg; BAR. PRES. 30.11  
Comp C-4; 1% of Charge Wt. WIND DIR. 150°  
 TEST NUMBER 16-6-02 C4 WIND VEL. 11 Knots  
 CONTRACT NO. NAS8-27750

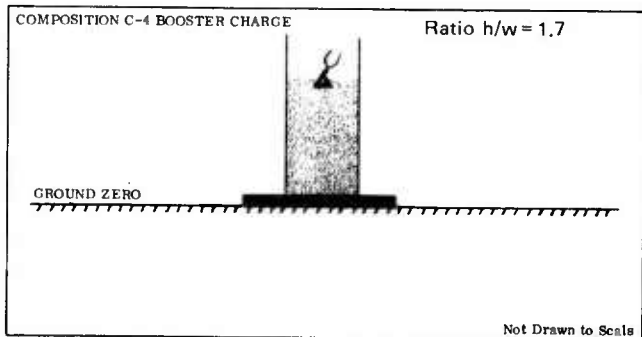

C <sub>4</sub> Test 65.77 kg M10 Propellant					
Channel No.	Distance Meters (ft.)	Peak Pressure kPa (psig)	Scaled Positive Impulse kPa.msec/kg <sup>1/3</sup> (psi.msec/lbs <sup>1/3</sup> )	Time of Arrival (msec)	Remarks
1	4.8 (15.76)	-	-	1.6	Cable damage.
7		965.3 (140)	333.4 (37.15)	1.8	
2	8.49 (21.28)	519.2 (84)	487.5 (53.44)	2.3	
8		827.4 (120)	345.3 (36.48)	3.1	
3	8.77 (28.78)	289.8 (42)	145.5 (16.21)	4.6	
9		386.1 (56)	170.7 (19.02)	5.4	
4	14.41 (47.28)	98.5 (14)	76.3 (8.50)	13.2	
10		82.7 (12)	71.5 (7.97)	15.6	
5	28.82 (94.56)	21.4 (3.1)	28.5 (2.85)	48.8	
11		20.7 (3)	32.8 (3.65)	51.1	
6	84.05 (210.14)	6.2 (0.9)	14.7 (1.64)	146.5	
12		9.0 (1.3)	11.8 (1.32)	148.5	

**FIELD EVALUATION**

Box orientation North and South  
 Crater dimension 0.46 meters deep by 3.56 meters wide

## Test Number 16-6-02 C5

TEST TITLE	Explosive Equivalency	DATE	4/15/78
TEST SAMPLE	M10 Propellant; M-24 Shipping Container	TIME	1301 Hrs.
SAMPLE WEIGHT	145 lbs/65.77 kg	TEMP.	81°F/27.2°C
IGNITION SOURCE	J-2 Engineer's Special Blasting Cap	HUMIDITY	51%
BOOSTER WT.	1.5 lbs/0.68 kg Comp C-4 1% of Charge Wt.	BAR. PRES.	30.11
TEST NUMBER	18-6-02 C5	WIND DIR.	105°
CONTRACT NO.	NAS8-27750	WIND VEL.	14 Knots

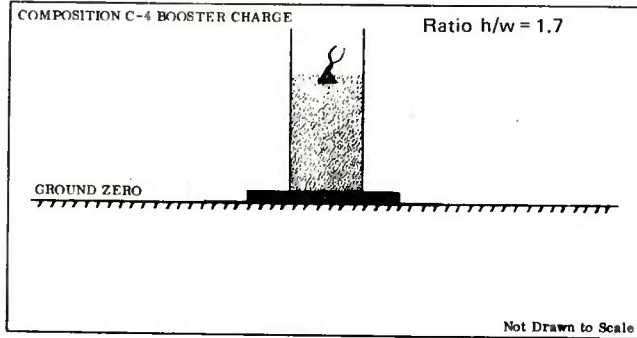

**FIELD EVALUATION**

Box orientation North and South

Crater dimension 0.37 meters deep by 3.01 meters wide

---



---



---



---

C <sub>5</sub> Test 65.77 kg M10 Propellant					
Channel No.	Distance Meters (ft.)	Peak Pressure kPa (psig)	Scaled Positive Impulse kPa.msec/kg <sup>1/3</sup> (psi.msec/lbs <sup>1/3</sup> )	Time of Arrival (msec)	Remarks
1	4.8 (15.76)	-	-	1.6	Hit??
7		1034.2 (150)	-	2.0	Failed to return to baseline
2	6.49 (21.28)	-	-	2.5	Transducer damaged
8		758.4 (110)	88.5 (9.86)	3.0	
3	8.77 (28.78)	-	-	3.8	Missed data
9		889.4 (129)	189.6 (21.13)	5.0	
4	14.41 (47.28)	75.8 (11)	65.3 (7.28)	12.2	
10		-	-	-	No data
5	28.82 (94.56)	20.7 (3)	30.9 (3.44)	48.1	
11		20 (2.9)	34.5 (3.85)	52.7	
6	64.05 (210.14)	12.4 (1.8)	14.9 (1.66)	145.2	
12		10.3 (1.5)	11.4 (1.27)	150.2	

## Test Number 17-7-01 D1

TEST TITLE	Explosive Equivalency Testing	DATE	4/19/76
TEST SAMPLE	M10 Propellant Scaled Shipping Container	TIME	1257 Hrs.
SAMPLE WEIGHT	25 lbs/11.34 kg	TEMP.	81°F/27.2°C
IGNITION SOURCE	J-2 Engineer's Blasting Cap	HUMIDITY	53%
BOOSTER WT.	0.25 lbs/0.11 kg Comp C-4 1% of Charge Wt.	BAR. PRES.	30.08
TEST NUMBER	17-7-01 D1	WIND DIR.	190°
CONTRACT NO.	NAS8-27750	WIND VEL.	10 Knots

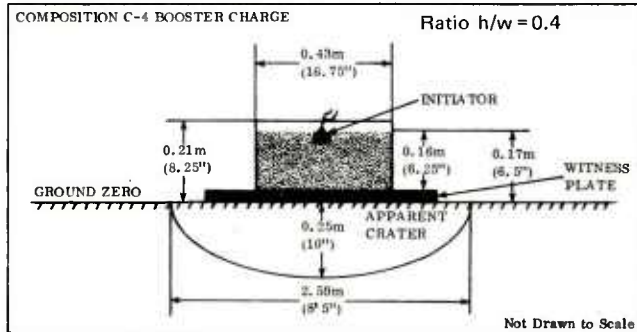

**FIELD EVALUATION**

Photographic coverage included Hycam (1500 fps) Hulchen (20pps) documentation (24fps)

Complete detonation. No visible signs of unburned propellant

Crater dimension 0.25 meter deep by 2.59 meters wide

Box orientation long side North and South.

---



---



---

D <sub>1</sub> Test 11.34 kg (25 lb) M10 Propellant					
Channel No.	Distance Meters (ft.)	Peak Pressure kPa (psig)	Scaled Positive Impulse kPa.msec/kg <sup>1/3</sup> (psi.msec/lbs <sup>1/3</sup> )	Time of Arrival (msec)	Remarks
1	2.87 (8.77)	1241.1 (180)	745.1 (83.024)	0.95	
7		1172.1 (170)	475.6 (53.0)	1.0	
2	3.61 (11.84)	820.5 (90)	331.03 (36.89)	1.8	
8		661.9 (98)	350.8 (39.01)	1.8	
3	4.80 (15.70)	227.5 (33)	149.7 (16.68)	3.25	
9		262.0 (38)	188.9 (21.05)	3.4	
4	8.02 (26.52)	79.3 (11.5)	71.7 (7.99)	9.4	
10		67.6 (9.8)	46.4 (5.17)	10.2	
5	18.04 (52.83)	22.8 (3.3)	26.1 (2.91)	29.45	
11		18.3 (2.8)	35.12 (3.91)	31.0	
8	35.7 (116.86)	6.2 (0.8)	19.6 (2.18)	83.2	
12		8.9 (1.0)	18.21 (2.03)	85.8	

### Test Number 17-6-01 D4

TEST TITLE	<u>Explosive Equivalency Testing</u>	DATE	<u>4/20/76</u>
TEST SAMPLE	<u>M10 Propellant; Scaled Shipping Container</u>	TIME	<u>1227 Hrs.</u>
SAMPLE WEIGHT	<u>25 lbs/11.34 kg</u>	TEMP.	<u>79°F/26.1°C</u>
IGNITION SOURCE	<u>J-2 Engineer's Special Blasting Cap</u>	HUMIDITY	<u>64%</u>
BOOSTER WT.	<u>0.5 lbs/0.23 kg, Comp C-4, 2% of Charge Wt.</u>	BAR. PRES.	<u>29.93</u>
TEST NUMBER	<u>17-6-01 D4</u>	WIND DIR.	<u>190°</u>
CONTRACT NO.	<u>NAS8-27750</u>	WIND VEL.	<u>11 Knots</u>

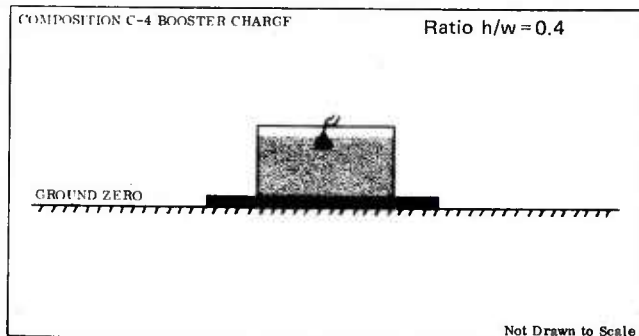

D <sub>4</sub> Test 11.34 kg (25 lb) M10 Propellant					
Channel No.	Distance Meters (ft.)	Peak Pressure kPa (psig)	Scaled Positive Impulse kPa.msec/kg <sup>1/3</sup> (psi.msec/lbs <sup>1/3</sup> )	Time of Arrival (msec)	Remarks
1	2.67 (8.77)	1172.1 (170)	591.8 (65.95)	1.15	
7		1241.1 (180)	878.7 (97.92)	1.0	
2	3.61 (11.84)	289.6 (42)	296.4 (33.03)	1.9	
8		537.8 (78)	335.1 (37.34)	1.6	
3	4.8 (15.70)	220.6 (32)	134.4 (14.98)	3.4	
9		386.1 (56)	148.3 (16.52)	2.75	
4	8.02 (26.32)	75.8 (11.0)	66.0 (7.35)	9.0	
10		41.4 (6.0)	42.9 (4.78)	8.8	
5	16.04 (52.63)	17.9 (2.6)	34.7 (3.86)	29.3	
11		16.2 (2.35)	36.5 (4.07)	29.7	
6	35.7 (116.96)	6.2 (0.9)	17.1 (1.91)	83.3	
12		6.9 (1.0)	16.2 (1.81)	84.1	

**FIELD EVALUATION**

Box orientation North and South

Crater dimension 0.27 meters deep by 2.97 meters wide

---



---



---

### Test Number 17-6-01 D5

TEST TITLE	<u>Explosive Equivalency Testing</u>	DATE	<u>4/20/76</u>
TEST SAMPLE	<u>M10 Propellant; Scaled Shipping Container</u>	TIME	<u>1300 Hrs.</u>
SAMPLE WEIGHT	<u>25 lbs/11.34 kg</u>	TEMP.	<u>83°F/28.3°C</u>
IGNITION SOURCE	<u>J-2 Engineer's Special Blasting Cap</u>	HUMIDITY	<u>63%</u>
BOOSTER WT.	<u>0.5 lbs/0.23 kg, Comp C-4, 2% of Charge Wt.</u>	BAR. PRES.	<u>29.93</u>
TEST NUMBER	<u>17-6-01 D5</u>	WIND DIR.	<u>180°</u>
CONTRACT NO.	<u>NAS8-27750</u>	WIND VEL.	<u>6 Knots</u>

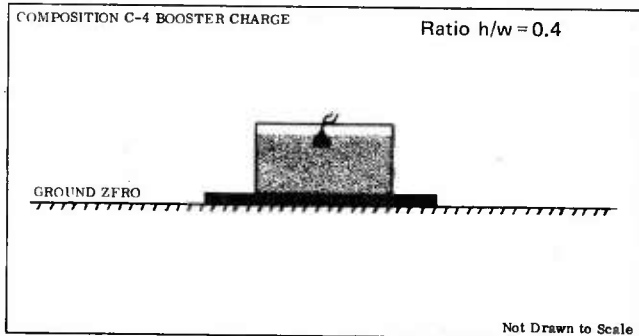

D <sub>5</sub> Test 11.34 kg (25 lb) M10 Propellant					
Channel No.	Distance Meters (ft.)	Peak Pressure kPa (psig)	Scaled Positive Impulse kPa.msec/kg <sup>1/3</sup> (psi.msec/lbs <sup>1/3</sup> )	Time of Arrival (msec)	Remarks
1	2.67 (8.77)	1241.1 (180)	619.3 (69.01)	1.1	
7		1241.1 (180)	551.9 (61.40)	0.9	
2	3.61 (11.84)	482.6 (70)	327.8 (36.53)	1.8	
8		806.7 (117)	390.2 (43.48)	1.65	
3	4.8 (15.7)	248.2 (36)	135.9 (15.15)	3.2	
9		317.2 (46)	169.7 (18.91)	3.2	
4	8.02 (26.32)	86.2 (12.5)	64.5 (7.19)	8.7	
10		62.1 (9.0)	49.5 (5.52)	9.4	
5	16.04 (52.63)	20.7 (3.0)	36.3 (4.04)	28.9	
11		17.9 (2.6)	39.0 (4.35)	30.1	
6	35.7 (116.96)	6.2 (0.9)	19.6 (2.19)	83.2	
12		6.9 (1.0)	18.6 (1.85)	84.8	

**FIELD EVALUATION**

Box orientation North and South

Crater dimension 0.30 meters deep by 2.95 meters wide

---



---



---

APPENDIX B

SELECTED PHOTOGRAPHS



PRETEST CONFIGURATION 22.68 kg CHARGE



POST TEST CRATER 22.68 kg CHARGE



PRETEST CONFIGURATION 45.4 kg CHARGE



POST TEST CRATER AND WITNESS PLATE

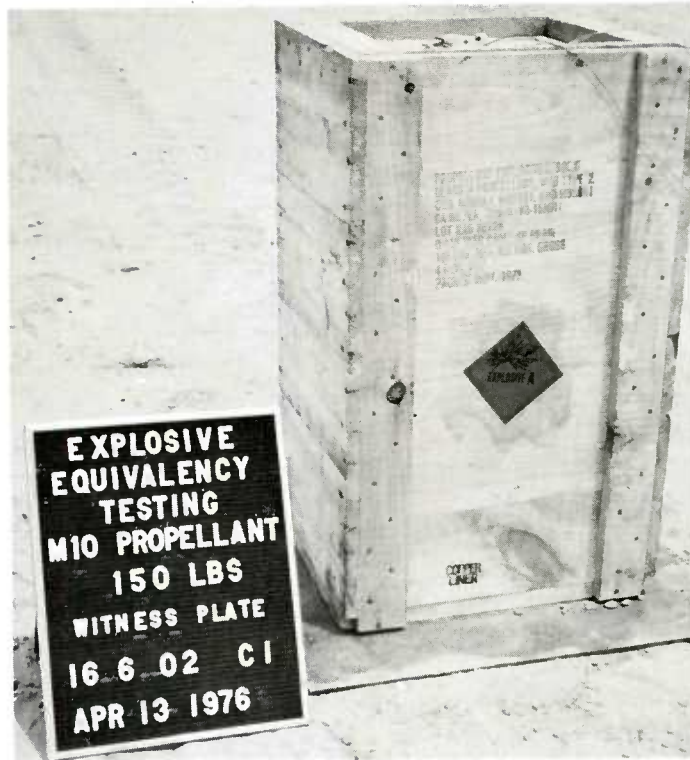

PRETEST CONFIGURATION 65.8 kg CHARGE



POST TEST CRATER 65.8 kg CHARGE

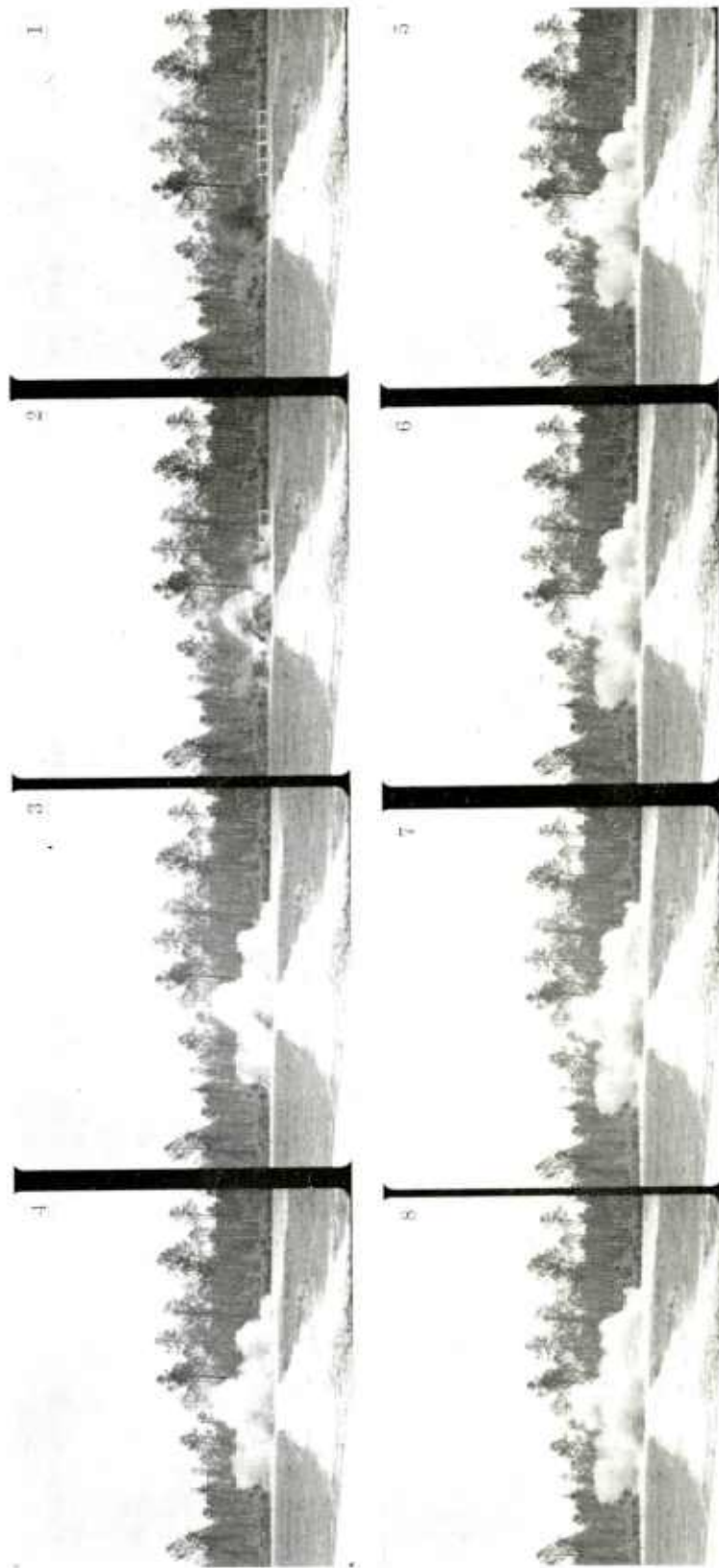

Fireball Characteristics from Hulcher Model 40  
Sequencing Camera (Frame Rate 50 ms/frame)  
22.68 kg Charge Weight

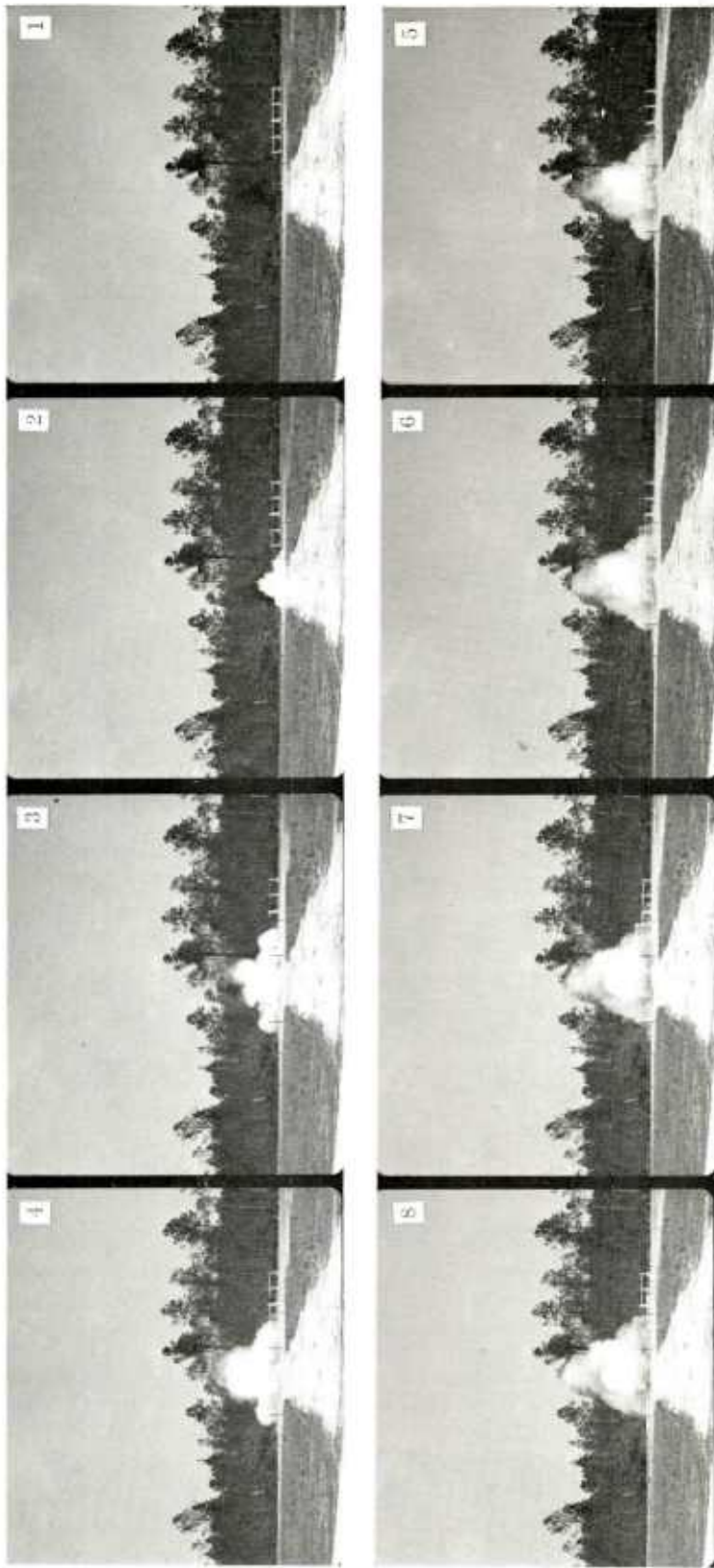

Fireball Characteristics from Hulcher Model 40  
Sequencing Camera (Frame Rate 50 ms/frame)  
11.34 kg Charge Weight



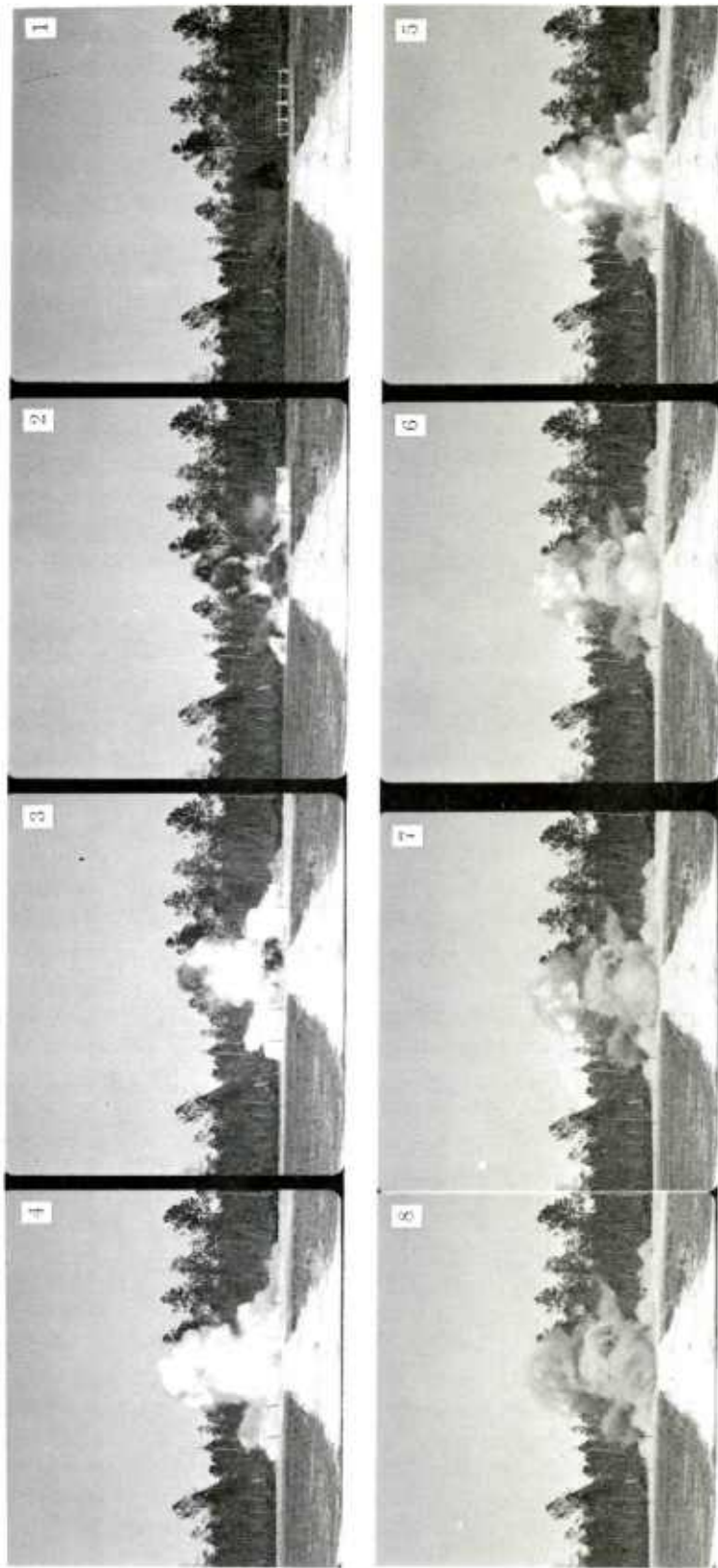

Fireball Characteristics from Hulcher Model 40  
Sequencing Camera (Frame Rate 50 ms/frame)  
45.4 kg Charge Weight

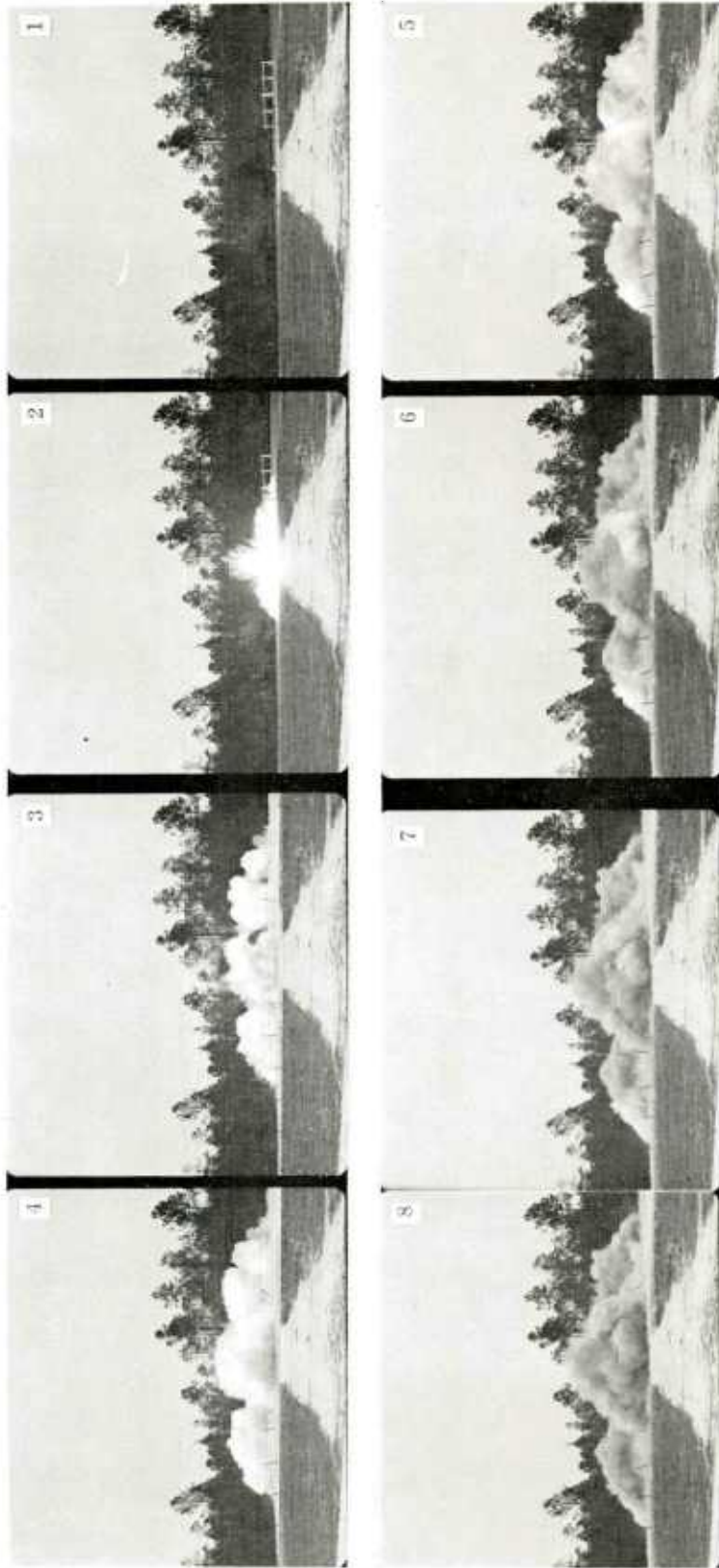

Fireball Characteristics from Hulcher Model 40  
Sequencing Camera (Frame Rate 50 ms/frame)  
65.8 kg Charge Weight

APPENDIX C  
SAFETY APPROVAL

Mr. Khwaja/cs/5441

DRSAR-IRC-E (2 Jun 77) 1st Ind  
SUBJECT: Preliminary Report, TNT Equivalency Test of M10 Propellant

HQ, US Army Armament Materiel Readiness Command, Rock Island, IL 61299

02 NOV 1977

TO: Commander, US Army Armament Research and Development Command,  
ATTN: DRDAR-LCM-SP, Dover, NJ 07801

1. Subject draft report on TNT Equivalency Test of M10 Propellant was reviewed and is approved by HQ, ARRCOM including DRSAR-SF and HQ, DARCOM, DRCSF-E.

2. Request ARRADCOM proceed with the final publication of the report.

FOR THE COMMANDER:

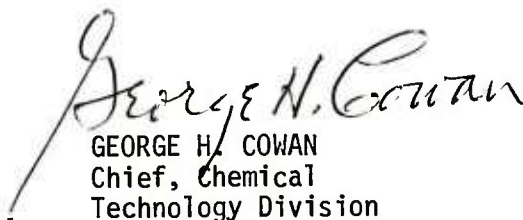
  
GEORGE H. COWAN  
Chief, Chemical  
Technology Division

wd all incl

CF:  
PM, MPBME  
(DRCPM-PBM-T-SF/  
DRCPM-PBM-LA/DRCPM-PBM-LN2)  
Cdr, DARCOM  
(DRCSF-E)

## DISTRIBUTION LIST

Commander

US Army Armament Research and Development Command

ATTN: DRDAR-CG  
DRDAR-LC  
DRDAR-LCM  
DRDAR-LCM-S (12)  
DRDAR-SF  
DRDAR-TSS (5)  
DRDAR-LCU-P

Dover, NJ 07801

Commander

US Army Materiel Development and Readiness Command

ATTN: DRCDE  
DRCIS-E  
DRCPA-E  
DRCPP-I  
DRCDI  
DRCSG-S

5001 Eisenhower Avenue  
Alexandria, VA 22333

Commander

USDRC Installations and Services Agency

ATTN: DRCIS-RI-IU  
DRCIS-RI-IC

Rock Island, IL 61299

Commander

US Army Armament Materiel and Readiness Command

ATTN: DRSAR-IR (2)  
DRSAR-IRC  
DRSAR-ISE (2)  
DRSAR-IRC-E  
DRSAR-PDM  
DRSAR-LC (2)  
DRSAR-ASF (2)  
DRSAR-SF (3)

Rock Island, IL 61299

Chairman  
Dept of Defense Explosives Safety Board  
Forrestall Bldg  
Washington, DC 20314

Project Manager for Munition Production  
Base Modernization and Expansion  
US Army Materiel Development and Readiness Command  
ATTN: DRCPM-PBM-LA  
DRCPM-PBM-SF  
DRCPM-PBM-EP (2)  
Dover, NJ 07801

Director  
Ballistic Research Laboratory  
ARRADCOM  
ATTN: DRDAR-BLE, C. Kingery (2)  
Aberdeen Proving Ground, MD 21010

Defense Documentation Center (12)  
Cameron Station  
Alexandria, VA 22314

Commander  
US Army Construction Engineering  
Research Laboratory  
ATTN: CERL-ER  
Champaign, IL 61820

Office, Chief of Engineers  
ATTN: DAEN-MCZ-E  
Washington, DC 20314

US Army Engineer District, Huntsville  
ATTN: Construction Division-HAD-ED (2)  
P.O. Box 1600 West Station  
Huntsville, AL 35807

Commander  
Indiana Army Ammunition Plant  
ATTN: SARIN-OR (2)  
SARIN-SF  
Charlestown, IN 47111

Commander  
Kansas Army Ammunition Plant  
ATTN: SARKA-CE  
Parsons, KS 67537

Commander  
Lone Star Army Ammunition Plant  
ATTN: SARLS-IE  
Texarkana, TX 57701

Commander  
Milan Army Ammunition Plant  
ATTN: SARMI-S  
Milan, TN 38358

Commander  
Radford Army Ammunition Plant  
ATTN: SARRA-IE (2)  
Radford, VA 24141

Commander  
Badger Army Ammunition Plant  
ATTN: SARBA (2)  
Baraboo, WI 53913

Commander  
Holston Army Ammunition Plant  
ATTN: SARHO-E  
Kingsport, TN 37662

Commander  
Iowa Army Ammunition Plant  
ATTN: SARIO-A  
Middletown, IA 52638

Commander  
Joliet Army Ammunition Plant  
ATTN: SARJO-SS-E  
Joliet, IL 60436

Commander  
Longhorn Army Ammunition Plant  
ATTN: SARLO-O  
Marshall, TX 75670

Commander  
Louisiana Army Ammunition Plant  
ATTN: SARLA-S  
Shreveport, LA 71102

Commander  
Newport Army Ammunition Plant  
ATTN: SARNE-S  
Milan, TN 38358

Commander  
Pine Bluff Arsenal  
ATTN: SARPB-ETA  
Pine Bluff, AR 71601

Commander  
Sunflower Army Ammunition Plant  
ATTN: SARSU-O  
Lawrence, KS 66044

Commander  
Volunteer Army Ammunition Plant  
ATTN: SARVO-T  
Chattanooga, TN 34701

Weapon System Concept Team/CSL  
ATTN: DRDAR-ACW  
Aberdeen Proving Ground, MD 21010

Technical Library  
ATTN: DRDAR-CLJ-L  
Aberdeen Proving Ground, MD 21010

Technical Library  
ATTN: DRDAR-TSB-S  
Aberdeen Proving Ground, MD 21005

Benet Weapons Laboratory  
Technical Library  
ATTN: DRDAR-LCB-TL  
Watervliet, NY 12189

Commander  
US Army Armament Materiel and REadiness Command  
ATTN: DRSAR-LEP-L  
Rock Island, IL 61299