

AD-A055 915

NAVAL RESEARCH LAB WASHINGTON D C  
A MULTIPLE RADAR INTEGRATED TRACKING (MERIT) PROGRAM.(U)  
APR 78 J D WILSON

F/G 17/9

UNCLASSIFIED

NRL-8200

SBIE-AD-E000 162

NL

1 of 1  
AD  
A055 915



END  
DATE  
FILMED  
8 -78  
DDC

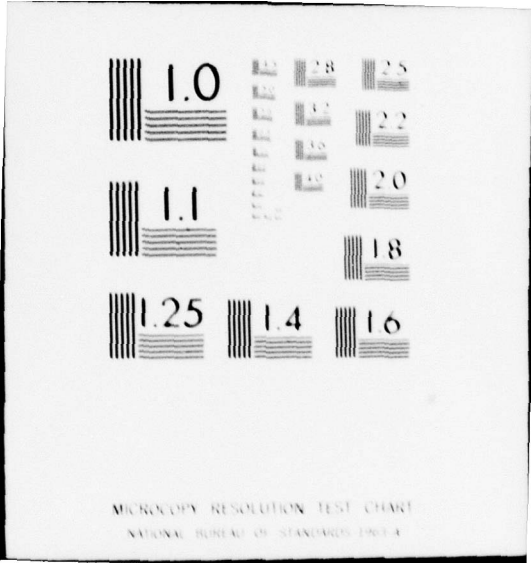

FOR FURTHER TRAN

16/9

ade 000162  
NRL Report 8200

AD A 055915

AD No. 1

JDC FILE COPY

6 A Multiple Radar Integrated Tracking (MERIT) Program.

10 J. D. WILSON  
Radar Analysis Staff  
Radar Division

12

9 Final rept.

11 3 Apr 1978

12 27 p.

14 NRL-8200

16 F12151

17 ZF12151001

18 SBIE

19 AD-E000/162

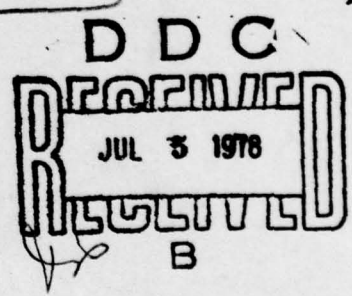

NAVAL RESEARCH LABORATORY  
Washington, D.C.

251 950

Approved for public release; distribution unlimited.

mt

SECURITY CLASSIFICATION OF THIS PAGE (When Data Entered)

REPORT DOCUMENTATION PAGE		READ INSTRUCTIONS BEFORE COMPLETING FORM
1. REPORT NUMBER NRL Report 8200	2. GOVT ACCESSION NO.	3. RECIPIENT'S CATALOG NUMBER
4. TITLE (and Subtitle) A MULTIPLE RADAR INTEGRATED TRACKING (MERIT) PROGRAM	5. TYPE OF REPORT & PERIOD COVERED Final report on one phase of a continuing NRL Problem	
	6. PERFORMING ORG. REPORT NUMBER	
7. AUTHOR J. D. Wilson	8. CONTRACT OR GRANT NUMBER(s)	
9. PERFORMING ORGANIZATION NAME AND ADDRESS Naval Research Laboratory Washington, D. C. 20375	10. PROGRAM ELEMENT PROJECT, TASK AREA & WORK UNIT NUMBERS NRL Problem R02-54 Project ZF12-151-001 Program element 62712N	
11. CONTROLLING OFFICE NAME AND ADDRESS Department of the Navy Office of Naval Research Arlington, VA 22217	12. REPORT DATE April 3, 1978	
	13. NUMBER OF PAGES 27	
14. MONITORING AGENCY NAME & ADDRESS (if different from Controlling Office)	15. SECURITY CLASS. (of this report)  UNCLASSIFIED	
	15a. DECLASSIFICATION/DOWNGRADING SCHEDULE	
16. DISTRIBUTION STATEMENT (of this Report)  Approved for public release; distribution unlimited		
17. DISTRIBUTION STATEMENT (of the abstract entered in Block 20, if different from Report)		
18. SUPPLEMENTARY NOTES		
19. KEY WORDS (Continue on reverse side if necessary and identify by block number)  MERIT Radar integration Automatic tracking		
20. ABSTRACT (Continue on reverse side if necessary and identify by block number)  A Multiple Radar Integrated Tracking (MERIT) Fortran program has been implemented on the ASC (Advanced Scientific Computer) at NRL. The program performs an automatic tracking function on data from one to five colocated radars with different radar parameters. The system will be used as a tool in evaluating various tracking concepts such as improved initiation, advanced correlation techniques, automatic radar control in adverse environments, optimal realizable tracking filters, and software stabilization of 2D radars. In conjunction with the SURDET program to simulate the detector output of a radar the tracking system can be used to evaluate proposed or existing radars in an automatic tracking role.		

DD FORM 1, JAN 73, 1473 EDITION OF 1 NOV 65 IS OBSOLETE  
S/N 0102-LF-014-6601

SECURITY CLASSIFICATION OF THIS PAGE (When Data Entered)

## CONTENTS

INTRODUCTION .....	1
BASIC TRACKING PHILOSOPHY .....	1
TRACKING-SYSTEM STORAGE FILES AND BASIC ROUTINES .....	2
Track-Number and Clutter-Number Files .....	2
Track and Clutter Parameter Files .....	3
Track-Number Assignment to Azimuth-Sector Files .....	4
Input Data Bank .....	7
TRACKING SYSTEM .....	8
Tracking Program Control Parameters .....	8
Individual Clutter Maps .....	11
Tracking Filter .....	12
Track Correlation and Updating .....	14
Track Initiation .....	15
Output Structure and Sample Output .....	16
FUTURE DEVELOPMENTS .....	19
Anticlutter and ECM Techniques .....	19
Initiation .....	19
Correlation .....	20
Filtering .....	21
Software Stabilization .....	22
SUMMARY .....	23
REFERENCES .....	24

PRECEDING PAGE BLANK

ACCESSION		
WTR	DDC	<input checked="" type="checkbox"/>
		<input type="checkbox"/>
DISTRIBUTION/AVAILABILITY CODES		
Dist.	AVAIL.	SPECIAL
A		

## A MULTIPLE RADAR INTEGRATED TRACKING (MERIT) PROGRAM

### INTRODUCTION

During fleet exercises in the 1960's, it was demonstrated that many targets were never detected by radar operators even though posttest analysis of video recordings of the radar data revealed that the radar return from targets was present in the raw video. Among the reasons operators missed targets were operator fatigue, collapsing of upper beams of the 3D radar onto a plan-position-indicator (PPI) display, and rain, land, and sea clutter. To improve its surveillance capability, the Navy decided to associate automatic detection and tracking (ADT) systems with its radars. Specifically, the SPS-48C and the radar video processor (RVP) for 2D radars have been approved for fleet operation.

On board most naval combat vessels are two kinds of surveillance radars: 2D and 3D. To better use the information aboard the vessel, the radar data from different radars should be integrated to yield a single track file. The benefits of such a system would be increased data rate, quicker track initiations, increased track life, and on-line redundancy. Therefore, in the spring of 1973, NRL started work on an automatic detection and integrated tracking (ADIT) system [1-5] that performs radar integration. Automatic detectors are associated with the 2D and 3D radars, and the centroided detections are integrated into a single track file in a minicomputer.

The Applied Physics Laboratory (APL) embarked on a program which resulted in the SYS-1-D system [6]. The SYS-1-D system adopted the NRL system philosophy (merging detections) and uses several other features that were generated by the ADIT program. The NRL ADIT system is a 6.2 research program, but the APL SYS-1-D system is a 6.4 program designed for fleet introduction. The SYS-1-D system will be tested in the fleet during 1978.

In this report a large computer implementation of an integrating tracking system is discussed. This tracker operates on suitably formatted detections from one to five sensors yielding a set of tracks. The tracker is essentially the ADIT tracking system [4, 5]. The motivation for this implementation is twofold: to evaluate radars from the viewpoint of their performance in an automatic-detection automatic-tracking mode, and to improve the performance of automatic trackers by investigating new techniques of track initiation, correlation, and filtering.

Being developed concurrently with the MERIT system is the SURDET [7] radar simulation. This program simulates the detector output of a radar and is the prime source of data for the MERIT program.

An overview of the tracking system and its operation is given along with an outline of possible modifications to improve tracking under various conditions of input data.

### BASIC TRACKING PHILOSOPHY

Before proceeding to the principal subject of this report, the method of integration will be discussed briefly. Of the several possible methods of radar integration the following ones are mentioned most frequently:

J.D. WILSON

- Detections from both radars are used to initiate and update tracks;
- Track is initiated on one radar, and detections from both radars are used to update tracks;
- Tracks from both radars are merged to yield a single track;
- One of the radars is chosen using a specified criterion, usually the highest quality track or earliest track.

The first method contains the maximum information, and all other methods can be considered to be special cases of it. Consequently, the first method will be used.

Three types of tracks are considered: clutter points (or slowly moving targets), target tracks, and tentative (or new) tracks. The tracks are correlated (associated) with the detections from the radars. The tracks are smoothed, and each target's position is predicted for the next time one of the radar beams will pass over the target. To reduce the number of correlations to be performed, the tracks are stored in azimuth sectors, and only those detections in the sector where the track is located and in neighboring sectors need be considered.

Most of the single-radar tracking systems use the radar itself for a clock, since the radar operates at a constant scanning rate. Although this system is similar to other tracking systems using a single radar, it differs from previous single-radar tracking systems in timing, filter updating, and track initiation as well as in the use of detections from several radars. In the next section the basic system parameters are defined and the basic routines are discussed.

#### **TRACKING-SYSTEM STORAGE FILES AND BASIC ROUTINES**

When a track is established in the software of the computer, it is convenient to assign a track number to it. With this system all parameters associated with a given track are referenced by this track number. Each track number is also assigned a sector (region of space in azimuth) for efficient correlation. In addition to the track files a clutter map is maintained. A clutter number is assigned to each stationary or very slowly moving target. All parameters associated with a clutter point are referenced by this clutter number. Again, each clutter number is assigned a sector in azimuth for efficient correlation.

#### **Tracking-Number and Clutter-Number Files**

The track-number and clutter-number files are the same as those described by Richeson of APL [8]. The parameters for the files are as follows:

NT	Track number,
NLT	Last track number,
FULLT	Number of available track numbers,
NEXTT	Next track number available,
LASTT	Last track number not being used,
LISTT (256)	File whose 256 locations correspond to track numbers,

NRL REPORT 8200

NC	Clutter number,
NCL	Last clutter number,
FULLC	Number of available clutter numbers,
NEXTC	Next clutter number available,
LASTC	Last clutter number not being used,
LISTC (256)	File whose 256 locations correspond to clutter numbers.

Only the operation of the track-number file will be described, since the operation of the clutter-number file is identical.

The track-number file is initiated by setting LISTT (I) = I + 1 for I = 1 through 255. LISTT (256) is set equal to 0 (denoting the last available track number in the file), NEXTT is set equal to 1 (the next available track number), LASTT is set equal to 256 (the last track number not being used), and FULLT is set equal to 255 (indication that 255 track numbers are available).

When a new track number is requested, the system checks to see if FULLT is 0. If FULLT is not 0, the new track is assigned the next available track number (NT = NEXTT). The next available track number in the list is found by setting NEXTT equal to LISTT (NT). FULLT is decremented, indicating that one less track number is available. Finally, LISTT (NT) is set equal to 512 (a number larger than the number of possible tracks). This is not necessary but helps in debugging the program.

A track number is dropped by setting the last available track number LISTT (LASTT) equal to the track number NT, which is dropped. LISTT (NT) is set equal to 0 to denote the last track number, and LASTT is then set equal to the track number being dropped (LASTT = NT). The parameter FULLT is incremented, indicating that one more track number is available.

The track-number and clutter-number files maintain a linkage from one number to the next, and they operate rapidly, eliminating searching techniques.

#### Track and Clutter Parameter Files

Parameters associated with track number NT are as follows:

RTR (NT)	Smoothed range of track, stored every TTR2CL seconds,
TLT2CL (NT)	Last time track NT checked for transfer to clutter file,
RS (NT)	Smoothed range position
AS (NT)	Smoothed azimuth position
ES (NT)	Smoothed height position
VRS (NT)	Smoothed range velocity
VAS (NT)	Smoothed azimuth velocity
VES (NT)	Smoothed height velocity

$x_s(k),$   
 $v_s(k),$



J.D. WILSON

RPT (NT)	Predicted range position	} $x_p(k)$ ,
APT (NT)	Predicted azimuth position	
EPT (NT)	Predicted height position (= ES (NT)),	
TTR (NT, IRAD)	Last time any particular radar (radar IRAD) updated track NT,	
TTL (NT, IRAD)	Next time radar IRAD has opportunity to update track NT,	
TT (NT)	Last time any radar updated track NT,	
FA (NT)	Azimuth of the initial detection of a tentative track,	
FE (NT)	Height of the initial detection of a tentative track,	
FVAR (J, NT)	Smoothed average of sensor measurement errors of sensor updating track NT in range (J = 1), azimuth (J = 2), and height (J = 3),	
XMANT (NT)	Time since the initiation of tentative track NT or the time since the last maneuver of firm track NT,	
TRKQAL (NT)	Time since the last 3D update on track NT,	
KT (NT)	Flag indicating a tentative (-1) or firm (0) track status for track NT,	
TF (NT)	Time of initiation of track NT.	

Parameters associated with clutter number NC are as follows:

RC (NC)	Range of the point clutter stored every TCL2TR seconds,
TLC2TR (NC)	Last time clutter point NC was checked for transfer to the track file,
RPC (NC)	Range of the point clutter,
APC (NC)	Azimuth of the point clutter,
EPC (NC)	Height of the point clutter (unused),
TC (NC)	Last time clutter NC was updated.

**Tracking-Number Assignment to Azimuth-Sector Files**

The azimuth-range plane is separated into equal azimuth sectors. After a track is updated or initiated, the predicted position of the target is checked to see which sector it occupies, and the track is assigned to this sector. If the track is dropped or moves to a new sector, it is dropped out of the sector in which it was previously located. The parameters associated with sector files are as follows:

ITBX (I)	First track number in sector I (a subscript of array IDT),
IDT (256)	Storage location, corresponding to one of the 256 track numbers and containing either the next track number in sector I or a 0.

NRL REPORT 8200

ICBX (I, IRAD)	First clutter number in sector I (a subscript of array IDC) from radar IRAD,
IDC (256)	Storage location, corresponding to one of the 256 clutter numbers and containing either the next clutter number in sector I or a 0.

The assignment of track numbers to azimuth cells will be described; the clutter-number assignment is similar, and the process is essentially the same as described in Ref. 3. The ITBX(I) file contains the first track number in sector I. If ITBX(I) = 0, there are no tracks in sector I. The IDT (256) file has storage locations corresponding to each of the possible 256 track numbers. The first track number in sector I is obtained from FIRST = ITBX(I). The second track number in the sector is obtained by NEXT1 = IDT (FIRST). The next track number in the sector is obtained by NEXT2 = IDT (NEXT1). This process is continued until a 0 is encountered, indicating that there are no more track numbers in the sector.

When a new track is added or a track moves from one sector to another, a track number must be added to the sector. When the track is a tentative (new) track, the track number NT is placed on the bottom of the stack. The file is traced as described until a 0 is encountered. If this occurs in IDT (NEXT), then IDT (NEXT) is set equal to NT and IDT (NT) is set equal to 0. If there were no tracks in this sector, then ITBX (I) is set equal to NT and again IDT (NT) is set equal to 0. When the track being transferred into a sector is a firm track, the first track number in the sector is stored, the track number NT being added is made the first track number in the sector, and the track number NT in the IDT (NT) file is made equal to the original first track number in the sector. This dual procedure ensures that first the firm tracks are processed from the top of the file and then the tentative tracks are processed from the bottom of the file.

When a track is dropped or moved out of a sector I, the track number must be removed from the sector files. To facilitate this removal, as each track number NT is processed, the last track number processed is saved in NTL. If NT is the first track number in the sector, NTL is 0. To drop track number NT, the procedure is as follows. When NTL is 0, ITBX (I) is set equal to IDT (NT), and IDT (NT) is set equal to 0. When NTL is not 0, IDT (NTL) is set equal to IDT (NT), and IDT (NT) is set equal to 0. This process shortcircuits the linkages through the sector file, eliminating the track number NT. Setting IDT (NT) equal to 0 has no function in the program other than as a debugging aid. The last step is to set NT equal to IDT (NTL) (or to ITBX (I)) to obtain the next track to be processed.

The flowchart for sector-file manipulation is shown in Fig. 1. A track does not change sectors if changing sectors would cause the track to miss an opportunity to be updated by another radar.

The only difference between the operation of the track-number assignments and clutter-number assignments is the existence of a clutter file for each radar. This was dictated by experiments on the ADIT system [5] using the SPS-12 and the SPS-39 radars. Observation of the detections of these two radars (one on L-band radar and the other on

S-band radar) demonstrated that few of the fixed clutter points were detected by both radars. The first clutter number in each sector is obtained from the ICBX file corresponding to that sector and the radar the detection comes from.

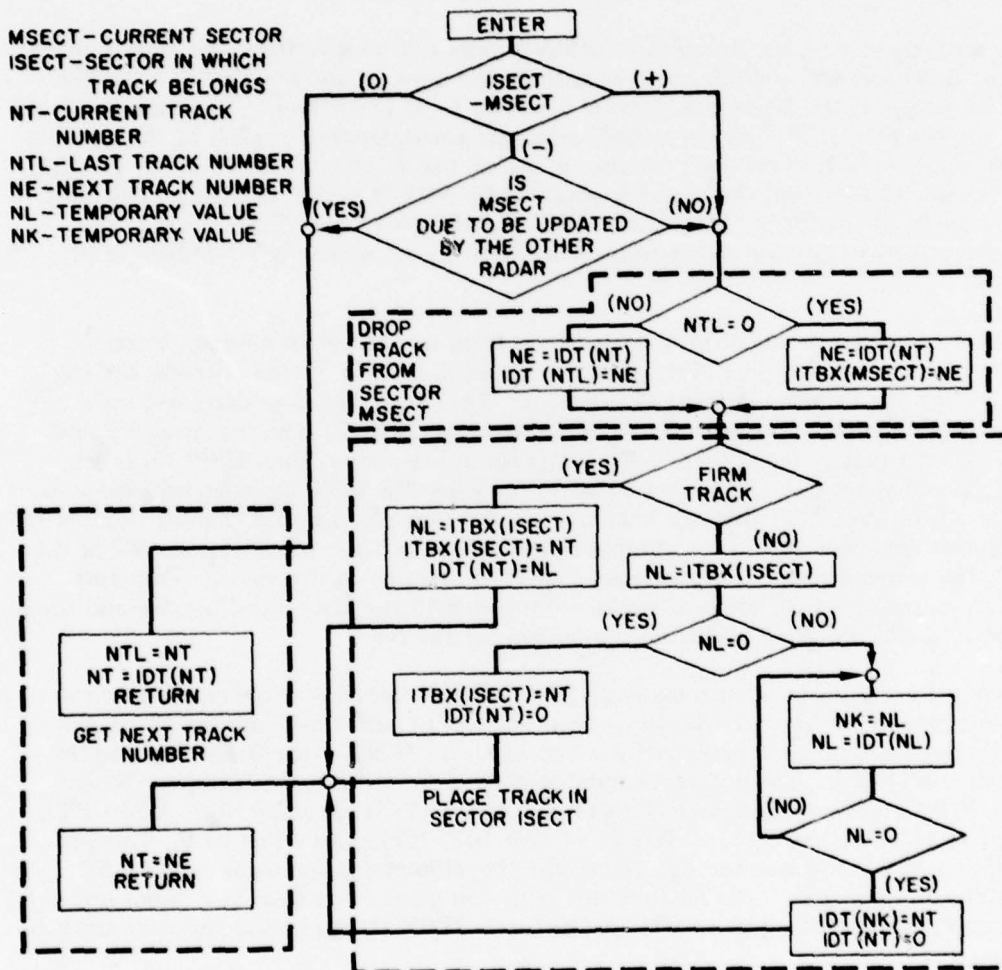

Fig. 1 - Sector-file manipulation

From then on, the operation of the clutter sector files is identical to the operation of the track sector files. With only one file (IDC) for clutter numbers, all 256 clutter numbers are available for use no matter how the fixed clutter points are distributed among the radars.

NRL REPORT 8200

**Input Data Bank**

The first set of data read by the tracking system is read only once and consists of the following input parameters:

NRAD	Number of radars,
RADTYP (IRAD)	Type (2D or 3D) of radar IRAD,
VROT (IRAD)	Rotation rate (radians/s) of radar IRAD,
IT (IRAD)	Initial azimuth sector of radar IRAD.

The basic input data from the radars can be broken into two categories: radar measurements and control parameters. The parameters associated with the input data are as follows:

RM (K, IRAD)	Range measurement of the Kth detection on radar IRAD,
AM (K, IRAD)	Azimuth measurement of the Kth detection on radar IRAD,
EM (K, IRAD)	Elevation measurement of the Kth detection on radar IRAD,
TM (K, IRAD)	Time of the Kth detection on radar IRAD,
TMRK (I, IRAD)	Time radar IRAD crosses sector I,
NP (I, IRAD)	Position of the pointer in the data buffer of radar IRAD in sector I,
NB (I, IRAD)	Number of detections from radar IRAD in sector I,
IT (IRAD)	Current sector of radar IRAD.

It would not be necessary to retain this type of buffered input in this version of the tracker, because the system obtains its data from mass storage. However it is convenient to retain this structure, because the logic is well developed and old detections are available for logic analysis.

The program expects the data to be made available from one source, with the data formatted into blocks such that each block corresponds to a sector of data from a radar. Each block begins with a set of control parameters, the radar, the sector, the time, the number of detections, and the buffer pointer. Following the control data are the measurements for each detection, the range, the azimuth, the elevation, and the time of detection.

To ensure that the data presented to MERIT are in the proper format, a program for merging radar data files (MRGRDR) reads data files from different radars (currently radars simulated by SURDET), partitions the detections into sectors, orders the sectors in time, and generates a data file with the proper format for MERIT. This program could be modified to operate on real radar data; however the data must be from colocated radars operated concurrently to be meaningful.

J.D. WILSON

## TRACKING SYSTEM

The tracking system has been discussed in previous reports on ADIT [4, 5]. The major change in the system is to allow data from one to five radars with arbitrary parameters (pulselength, beamwidth, scan rate, etc.) to be integrated rather than data from exactly two particular radars. Briefly, the major features of the system are: a method of adjusting the tracking parameters to the characteristics of each radar, an individual clutter map for each radar which eliminates detections that correlate with a fixed clutter point, a tracking filter to estimate track parameters, a correlation logic to associate detections with the proper track, a method of initiating new tracks in the system, and a method of conveying information to the user on the operation of the system. Each of these topics is covered in a following subsection.

### Tracking Program Control Parameters

To retain as much flexibility as possible, many parameters of the tracking system are defined when the program is run. The parameters are generally those that should be based on the quality of the detection data. The parameters and their explanations are as follows.

#### Miscellaneous Parameters

SCNFRT (usually 1 s). If a clutter point or track has shifted sectors, the same radar could attempt to update it twice on the same scan. SCNFRT is a time delay used to inhibit correlations, and would change only in exceptional circumstances, such as when a radar had a very fast scan rate.

NSECT (usually 64). This is the number of azimuth sectors and would change only for a radar with such poor azimuth accuracy that a detection could occur more than one sector away than the sector of the track.

NSECSH (usually 8). The rotation rate of the radar is calculated and smoothed every NSECSH sectors, and this number of sectors would change only if some feature of the radar necessitated a change in frequency of update.

ICBIAS (usually 6). This is the lag of processing behind the position of radar and would change only if the program was changed to perform additional functions such as merging detections or removing biases between radars.

NKON (usually 5). This is the total number of track correlation-region sizes, which can be increased to 10 to allow finer discrimination in dense target environments.

IFLAG (usually 0). A value of 1 for IFLAG forces use of all NKON correlation regions. A value of 0 means that on tracks with "good" velocity estimates only the smaller correlation-region sizes are used.

IPCTR. This is the output control; 0 implies firm tracks only, 1 implies firm tracks plus firm-track comments, 2 implies firm and tentative tracks only, 3 implies firm and tentative tracks plus track comments, and 4 implies firm and tentative tracks plus all comments. Track information consists of the values of all the critical track parameters

NRL REPORT 8200

at each opportunity to update the track; comments are remarks on significant events involving a track or clutter such as being dropped, being converted from a track to a clutter, or noting which detections correlate with a clutter point.

*Filter Parameters*

FLTNUM (J, IRAD) and FLTDNM (J, IRAD). These are the numerator and denominator used in an equation to set the filter bandwidth in the range (J = 1), azimuth (J = 2), and height (J = 3) tracking filters for radar IRAD as a function of track "quality".

XI (usually 0.6). This is the damping factor of the filter.

DTEL (usually 30 s). This is the maximum time between elevation updates on a track for good elevation information. The present value may be altered after evaluation.

RCRIT (usually 0.5 n.mi.). When the error between predicted position and measured position exceeds RCRIT, a target maneuver is indicated. The value depends on tracking accuracy.

*Track "Quality" Parameters*

MXMNT (usually 90 s). This is the largest value that the track parameter XMANT is allowed to achieve. There is no reason for this parameter to change with current logic.

FIMANT (usually 5.6 s). A time XMANT larger than the time FIMANT indicates a good "quality" tentative track and forces a reduction in the number of correlation regions used. Usually 5.6 s represents the minimum time since initiation to obtain good velocity information.

FMANT (usually 10 s). A time XMANT larger than the time FMANT indicates a good "quality" firm track and forces reduction in the number of correlation regions used.

TFMNT (usually 2 s). If the time XMANT is less than the time TFMNT, the time base is too short for useful velocities to be calculated for a tentative track.

FFMNT (usually 0.8 s). If time since last update for a firm track is less than FFMNT, the timebase is too short for a valid correction to be made to velocity.

*Time Parameters*

TCL2TR (usually 20 s). Every TCL2TR seconds a clutter is checked for motion by calculating a range velocity based on the current range and the stored range from TCL2TR seconds ago. Clutter points with velocities greater than DIFCT (IRAD) will be converted to tracks.

TTR2CL (usually 20 s). This is the time base for calculating a velocity for a firm track. Tracks with velocities smaller than DIFTC will be converted to clutter points.

TCMAX (usually 30 s). This is the time an unupdated clutter point is retained and is a function of the scan rates of the radars.

J.D. WILSON

TTMAX (usually 20 s). This is the time an unupdated firm track is retained and is a function of number of radars, scan rates, probability of detection, etc.

TNMAX (usually 15 s). This is the time an unupdated tentative track is retained and is a function of number of radars, scan rates, probability of detection, etc. TNMAX should be less than TFIX.

TFIX (usually 20 s). An update to a tentative track at a time subsequent to TFIX seconds after initial detection causes an assignment of the track to the clutter map or firm-track status based on a comparison to the velocity parameters VRMIN and VAMIN. TFIX should exceed TNMAX.

TUPTD (usually 12 s). If the time since the last update of a firm track exceeds TUPTD, then more correlation regions are used to compensate for a less reliable predicted position. TUPTD depends on expected error in predicted position and the effect of a target maneuver.

TICLUT. From the time the tracking system starts until time TICLUT, only clutter points are established to avoid an initial overload of the tracking system with tentative tracks based on fixed clutters. The elapsed time usually equals two scans of the slowest scanning radar.

*Velocity Parameters*

VRMIN (usually 50 knots) and VAMIN (usually 0.0001 rad/s). Tentative tracks with range velocity less than VRMIN and azimuth velocity less than VAMIN are converted to clutter points; otherwise they are converted to firm tracks,

DIFTC (usually 50 knots). A track whose average range velocity over the time interval TTR2CL is less than DIFTC may be converted to a clutter point.

DIFCT (IRAD) (usually 50 knots). A clutter point maintained by radar IRAD whose average velocity over the time interval TCL2TR is greater than DIFCT (IRAD) is converted to a firm track.

*Radar Measurement Variance Parameters*

RVAR (IRAD). This is the variance in range measurements on radar IRAD. RVAR is a function of compressed pulse length P and usually equals  $P^2/12$  expressed in nautical miles.

AVAR (IRAD). This is the variance in azimuth measurements on radar IRAD. AVAR is a function of antenna beamwidth B and usually equals  $(B/10)^2$ , the accuracy possible with the signal-to-noise ratio necessary for detection.

EVAR (IRAD). This is the variance in elevation measurements on radar IRAD. EVAR is a function of antenna elevation beamwidth E and the type of elevation scanning employed. As a worst case (the assumption of discrete beam positions with a detection in only one beam) the variance equals  $E^2/12$ .

### *Clutter Correlation-Region Size*

CRC (IRAD). This is the range correlation-region size on radar IRAD. The usual value is one range cell in nautical miles.

CAC (IRAD). This is the azimuth correlation-region size on radar IRAD. There is some indication that this is more a function of the spatial distribution of the scatterers causing the clutter detection than of the azimuth beamwidth of the radar.

CEC (IRAD). This is the maximum elevation a detection from radar IRAD may have to be allowed to update a clutter point. It is a function of elevation accuracy and terrain geometry.

### *Track Correlation Sizes*

CRT (I, IRAD). This is the Ith range correlation-region size (n.mi.) on radar IRAD.

CAT (I, IRAD). This is the Ith azimuth correlation-region size (radians) on radar IRAD.

CET (I, IRAD). This is the Ith elevation correlation-region size (radians) on radar IRAD. The values for all of the correlation-region sizes depend on the radars, the environment, the scenarios, and the operational requirements.

### *Individual Clutter Maps*

An individual clutter map removes from the detection files of the associated radar any detections which correlate with clutter points or slowly moving targets. The decision to implement individual clutter maps was based on experiments with the ADIT system involving an L-band and an S-band radar [5]. Examination of the data files revealed that of the clutter points consistently detected, only a small percentage were detected by both radars. Thus a detection from radar A will not update a clutter point generated by radar B and will be available to update the appropriate track.

The mechanics of a single individual clutter map are as follows: Given that radar IRAD is due to update sector ID of the track map; then sector ISECT = ID + 3 of the clutter map of radar IRAD should be updated. The correlation and updating is performed through nested iterations. First each eligible clutter point is obtained and a correlation is attempted with each eligible detection. The eligible clutter points are any clutter points in sector ISECT which have not been updated already on the current scan of radar IRAD. (This could occur when a clutter point in sector ISECT - 1 is updated with a detection which moves it to sector ISECT.) The eligible clutter points are obtained through linkage provided by the clutter azimuth-sector files (described earlier). The eligible detections are obtained from the input data files in the sectors ISECT - 1, ISECT, and ISECT + 1. The detection parameters are located sequentially and referenced using NP (I, RAD), which is the last detection in sector I from radar IRAD, and NB (I, IRAD), which is the number of detections in sector I by radar IRAD. Each clutter point is obtained, checked to



determine that the last update was at least one scan ago, and then retained while each eligible detection is compared in range, azimuth, and elevation for correlation. Each detection that correlates is eliminated from the detection file. The detection nearest the clutter point in the maximum-likelihood sense is used to update the clutter using a simple  $\alpha$  filter ( $\alpha = 0.5$ , the average of the two positions). The meaning of the maximum-likelihood sense is that the error metric is the range error squared, divided by the variance of range measurement error, plus the azimuth error squared, divided by the variance of the azimuth measurement error. The time of the update is saved, and the sector of the clutter point is changed if necessary. Unupdated clutter points are checked for elimination; updated clutter points are checked for motion and conversion to a track. If a clutter point from the clutter map from radar IRAD is converted to a track, the remaining clutter maps are searched for a corresponding clutter point, which is dropped to keep it from stealing detections from the newly created track.

In summary, the clutter files store the location of the clutter points or slowly moving targets and remove detections from the radar file that correlate with them. If too long a time elapses between updates, the clutter point is dropped. If the clutter point has sufficient velocity, it is converted to a track.

#### Tracking Filter

The tracking filter implemented is an  $\alpha$ - $\beta$  filter with a decreasing bandwidth and a turn detector. The  $\alpha$ - $\beta$  filter equations used for range and azimuth after a firm target has been established are

$$x_s(k) = x_p(k) + \alpha_k [x_m(k) - x_p(k)],$$

$$v_s(k) = v_s(k-1) + \frac{\beta_k}{T_k} [x_m(k) - x_p(k)],$$

and

$$x_p(k+1) = x_s(k) + v_s(k) T_{k+1},$$

where

- $x_s(k)$  = smoothed position,
- $x_p(k)$  = predicted position,
- $\alpha_k$  and  $\beta_k$  = system gains,
- $v_s(k)$  = smoothed velocity,
- $T_k$  and  $T_{k+1}$  = sampling periods, and
- $x_m(k)$  = measured position.

The system gains  $\alpha_k$  and  $\beta_k$  are set by

$$\alpha_k = 1 - e^{-2\xi\omega_0 T_k}$$

and

$$\beta_k = \frac{\alpha_k^2}{2 - \alpha_k},$$

where  $\xi$  is the filter damping coefficient and  $\omega_0$  is the filter bandwidth. The filter bandwidth is calculated from

$$\omega_0 = \frac{\text{FLTNUM}(J, \text{IRAD})}{\text{FLTDNM}(J, \text{IRAD}) + \text{XMANT}} * \frac{\text{FVAR}(J, \text{NT})}{\text{VAR}(\text{IRAD})},$$

where  $J = 1$  or  $2$  refers to range or azimuth, IRAD refers to updating with radar IRAD, and NT is track NT. FLTNUM and FLTDNM are tracking program control parameters associated with the filter. VAR is the tracking program control parameter for the measurement variance in range or azimuth for radar IRAD. FVAR is a past history of the measurement errors of the radars which have updated track NT. FVAR is updated by a simple  $\alpha$  filter with the measurement variance of each radar as it updates the track. XMANT is the time interval over which an accurate track has been maintained. When a track is made firm, XMANT retains the time since the track was initiated. When a track is updated with a small range error, XMANT is set by

$$\text{XMANT} = \text{MIN}(\text{XMANT} + T_k, \text{MXMNT}),$$

and when a track is updated with a large range error (indicating a maneuver), XMANT is set to 0.11 s (an arbitrary small time for debugging purposes). Specifically, a range error is small or large depending on whether the error between the predicted range and the measured range is less than the tracking program control parameter RCRIT. The parameters FLTNUM, FLTDNM, and MXMNT are chosen to yield a range of bandwidth values from 1/36 to 1/6. Experiments with ADIT indicate that  $\omega_0$  may be too small for slowly turning targets; that is, the error builds slowly until the bandwidth is suddenly increased. This would be a matter for investigation if this type of filter is retained.

We have modified the filter described above to operate on elevation information. This is because we may have updates on both 2D and 3D radars and the accuracy of elevation measurements is poor relative to the range of elevations we expect to observe. If the update information is derived from a 2D radar, no elevation updating is possible. If elevation information is available, the smoothing is as follows: The target is assumed to be constant in altitude, and the filtering is done in height not elevation. The filter is a variable-bandwidth  $\alpha$  filter. The velocity is assumed to be zero, and we merely attempt to follow the track height using the  $\alpha$  filter. The bandwidth is a function of range rate and elevation angle modified by the past history of measurement-error variances divided by the current measurement-error variance. The smoothing gain  $\alpha$  is calculated by

$$\alpha = 1 - e^{-2\xi\omega_0 TQ},$$

where  $TQ$  is the time since the last update with a 3D radar. With large  $TQ$ ,  $\alpha \rightarrow 1$  and the smoothed height becomes the measured height.

Tentative tracks are updated differently. With so little past history available the principal effort is to obtain the best estimates possible for the track for use at such time as the track is made firm. To accomplish this, the initial range and azimuth are stored, at each update the smoothed range and azimuth are set to the measured range and azimuth,

J.D. WILSON

and the measured height is averaged with the smoothed height. If a sufficient time base exists (time since initiation greater than TFMNT), the range rate and azimuth rate are estimated using the stored values at initiation and the current measured values.

### Track Correlation and Updating

Before the correlation begins, the tracks which have already been updated on the current scan by this radar are flagged. This can occur when a track changes sectors. The tracks are obtained through the operation of the track azimuth-sector files.

The track correlator attempts to minimize incorrect correlations by multiple passes through the track files with incremented correlation-region sizes. The track is updated in only one sector (primary sector). The tracks located in the two sectors in advance of the primary sector (secondary sectors) are correlated with detections also but are not updated. If a detection correlates with a track in the primary sector and is the minimum-distance correlation with the target, the detection is used to update the target track and is dropped from the detection file. A tentative track which is being updated is transformed to a target track TFIX seconds after initiation. The flag denoting that it was a tentative track is removed. If the track is in a secondary sector, the detection is flagged. This flag prohibits the detection from updating a track in the primary sector on some later pass through the track file using a larger correlation-region size on the basis that the detection has already been demonstrated to be closer to some other track. Each track which correlates with a detection is also flagged. This prevents the correlator from accessing the track again.

The finer the correlation-region increments, the better the correlation will perform in terms of the only judgment criterion available to it: the proximity of detection to a predicted track position. In most instances this correlation procedure prevents a track which is not detected on the current scan from stealing a detection from a nearby track.

When more than one detection correlates with a track, the "closest" detection in the maximum-likelihood sense is used to update the track. The definition for maximum-likelihood is similar to the definition given in the discussion of the clutter maps but, if possible, includes a term for elevation error. This is possible only if the current radar is a 3D radar and if the track has been updated recently (last DTEL seconds) by a 3D radar. The coordinates of this detection are used in the smoothing filter to update the track parameters. Then the time this track will be seen by the next radar is calculated, and the position of the track at that time is predicted.

Before a return to the executive the tracks must be prepared for the next correlation process. First all flags are removed from the tracks, and any unflagged tracks in the primary sector are coasted, using the stored velocities, or dropped if too much time has elapsed since the last update. Then each track that has changed sectors is placed in the correct sector file. Firm tracks are placed at the top of the sector file, and tentative tracks are placed at the bottom. This insures that as the tracks are sequentially processed by the correlator, the established tracks will have the first opportunity to be updated with each incremental correlation region. As additional effort to eliminate false correlations, especially in the case of a missed detection on a track, restrictions are set on the maximum

## NRL REPORT 8200

errors allowed, dependent on the past history of the track. This is done by limiting the number of correlation regions used by each track through the following logic:

- A track is limited to using four regions if it (a) is a tentative track with  $XMANT(NT) \leq FIMANT$  or (b) is a firm track with time since last update  $> TUPDT$  and  $XMANT(NT) \leq FMANT$ ;
- A track is limited to using three regions if it is a firm track with time since last update  $> TUPDT$  or  $XMANT(NT) \leq FMANT$ ;
- A track is limited to using two regions if it is a tentative track with  $XMANT(NT) > FIMANT$  or is a firm track.

A track uses the largest number of correlation regions for which it qualifies. The conditions given boil down to the conditions that the track has been moving in a straight line for some time, there is a good velocity measurement, and the information on the track is current.

One last function of the correlation routine is to periodically (every TTR2CL seconds) examine the average range velocity of each track to see if it should be converted to a clutter point (velocity less than DIFTC).

### Track Initiation

The method of track initiation is the weakest area of this particular tracker. This is because in the original realtime ADIT system, implemented on a Data General NOVA 800 (a minicomputer with an 800-ns cycletime and 32,000 16-bit words), there was insufficient time and space to implement a more sophisticated initiation algorithm. However, because an investigation of initiation techniques is one of the first items to be attacked with this new tool, it was decided to adopt the ADIT philosophy with minor changes.

The initiation technique currently used is as follows: Until time TICLUT, only clutter points are established by detections left in the input file after the correlation process is finished. After time TICLUT only tentative tracks are established. At the first update of a tentative track more than TFIX seconds after initiation, a decision is made, based on track trajectory (velocity and height), to convert the tentative track to either a firm track or a clutter point.

In an environment of a low density of detections this algorithm is highly effective. Random false alarms have low probability of correlating, and although tentative tracks are initiated for each false alarm, they are dropped before they are converted to firm tracks. The method is fast and simple to implement and there is no storing of uncorrelated detections, no generation of possible tracks, and no testing of these tracks for reasonable trajectories. In a scenario involving a raid or a region of high false-alarm density where detections may have multiple correlations, a more sophisticated technique involving the preceding operations will be necessary. Such a technique will be discussed in a later section.

**Output Structure and Sample Output**

Currently there is no internal evaluation of track quality. All evaluations of surveillance-radar detection performance and tracking program performance are by the user. As an aid to the user five increasingly detailed levels of printout are available. Level 0, displayed in Fig. 2a, lists each opportunity of updating a firm track. A zero measured range (third column) indicates that, for whatever reason, the track was not updated. Level 1, displayed in Fig. 2b, includes the information of level 0 plus remarks on the origins of tracks (promoted from tentative track, transferred from clutter file) and dispositions of tracks (dropped from file, transferred to clutter file). Level 2, displayed in Fig. 2c, lists the information of level 0 for both firm and tentative tracks but no remarks. Tentative tracks are identified by the addition of 1000 to the track number (first column). Thus 1005 is tentative track 5; if the track is converted to a firm track, 1005 becomes 5. Level 3, displayed in Fig. 2d, includes the level-2 updates on firm and tentative tracks and, in analogy to level 1, also includes remarks on the origins and dispositions of the firm and tentative tracks. Level 4, displayed in Fig. 2e, contains the information of level 3 plus information on clutter points. This information includes the creation and deletion of clutter points, lists all detections which correlate with the clutter point, and lists the parameters of the clutter point and the detection used to update it. Level 4, when used on data derived from the SURDET radar program, enables the user to determine what happens to every detection presented to the tracking program. This is possible because every detection from the SURDET program is coded to reveal its source: valid target, fixed clutter, or variable clutter.

TRACK	ENTER	MEAS. RANG.	MEAS. RANG.	MEAS. RANG. VEL.	MEAS. AZ.	MEAS. AZ.	MEAS. ALTITUDE	PRED. ALTITUDE	TIME	STATUS	TOTAL
5	2	55.10	55.10	+1027.57	100.50	100.50	2.07	1.00	57.50	21.00	0.00
5	1	55.10	55.10	+1027.58	100.50	100.51	0.00	1.00	58.50	20.00	1.00
5	3	55.21	55.21	+1027.57	100.50	100.50	2.00	1.02	57.00	20.00	0.00
5	2	55.27	55.27	+1012.17	100.49	100.49	1.74	1.00	55.00	20.00	0.00
5	1	55.18	55.18	+1012.17	100.51	100.50	0.00	1.05	55.00	20.00	0.00
5	1	51.00	51.00	+1012.15	100.78	100.57	2.51	1.00	56.00	31.00	0.00
5	1	51.20	51.20	+1021.60	101.02	100.51	0.00	1.00	59.00	31.00	1.00
5	2	51.10	51.10	+1021.60	101.27	100.57	2.17	1.00	59.00	31.00	0.00
5	1	00.00	00.00	+1021.50	100.79	100.50	2.29	2.00	51.00	30.00	0.00
5	1	00.10	00.10	+1010.83	101.88	100.50	0.00	2.02	02.00	30.00	1.00
5	2	00.03	00.03	+1013.10	100.41	100.50	0.00	2.15	02.00	30.00	0.00
5	1	07.00	07.00	+1013.28	100.83	100.52	2.10	2.03	00.00	03.00	0.00
5	1	07.00	07.00	+1021.10	101.00	100.50	0.00	2.00	07.00	03.00	1.00
5	2	00.70	00.70	+1022.53	101.18	100.50	2.01	2.00	00.00	00.00	0.00
5	1	00.00	00.00	+1022.05	100.82	100.50	2.00	2.00	01.00	00.00	0.00
5	1	00.50	00.50	+1031.87	101.00	100.57	0.00	2.00	02.00	00.00	1.00
5	2	02.50	02.50	+1027.10	100.53	100.55	1.05	2.00	05.00	00.00	0.00
5	1	03.00	03.00	+1027.09	100.55	100.52	1.05	1.05	06.00	00.00	0.00
5	1	03.00	03.00	+1027.15	100.92	100.51	0.00	1.05	07.00	00.00	0.00
5	2	02.01	02.01	+1020.01	100.80	100.47	1.01	1.05	00.00	00.00	0.00
5	1	02.07	02.07	+1020.01	100.88	100.50	1.00	1.05	01.00	00.00	0.00
5	1	01.01	01.01	+1020.01	101.20	100.40	0.00	1.05	00.10	00.00	0.00
5	2	00.20	00.20	+1023.67	100.44	100.05	1.31	1.05	00.00	01.00	0.00
5	1	00.10	00.10	+1023.67	100.73	100.44	1.33	1.00	00.00	01.00	0.00
5	1	00.47	00.47	+1023.67	100.53	100.40	0.00	1.00	00.00	02.00	0.00
5	1	00.13	00.13	+1023.60	100.60	100.37	1.00	1.00	01.00	00.00	0.00
5	2	00.00	00.00	+1023.60	100.82	100.42	1.00	1.00	01.00	00.00	0.00
5	1	00.00	00.00	+1023.60	100.30	100.42	0.00	1.00	01.00	00.00	0.00
5	1	00.15	00.15	+1023.62	100.64	100.35	1.00	1.00	00.00	01.00	0.00
5	1	00.00	00.00	+1023.62	100.00	100.40	0.00	1.00	00.00	02.00	0.00
5	2	00.00	00.00	+1023.62	100.60	100.40	1.10	1.00	00.00	02.00	0.00
5	1	00.20	00.20	+1011.71	00.00	100.34	0.00	1.00	01.00	00.00	0.00
5	1	00.10	00.10	+1011.71	100.82	100.22	1.02	1.00	01.00	00.00	0.00
5	2	00.70	00.70	+1012.60	100.67	100.20	1.12	1.00	02.00	00.00	0.00
5	1	02.30	02.30	+1010.01	00.70	100.10	0.00	1.00	00.10	01.00	0.00
5	1	02.21	02.22	+1010.01	100.43	100.11	1.01	1.00	00.00	01.00	0.00
5	2	01.50	01.57	+1010.02	100.80	100.09	1.00	1.00	00.00	03.00	0.00
5	1	00.00	00.00	+1010.10	00.00	100.00	0.00	1.00	00.00	00.00	0.00
5	3	00.20	00.20	+1010.10	100.80	00.00	1.00	1.00	01.00	00.00	0.00
5	2	00.10	00.10	+1010.10	100.41	00.00	1.00	1.00	01.00	00.00	0.00

Fig. 2a - Level 0 printout, the lowest level of five increasingly detailed levels of printout available to the user

THIS PAGE IS BEST QUALITY PRACTICABLE  
FROM COPY FURNISHED TO DDC



THIS PAGE IS BEST QUALITY PRACTICABLE  
FROM COPY FURNISHED TO DDC

J.D. WILSON

TRACK	SEAS. AZ.	HEAS. HGT	PRD. HGT	TIME	STANT	TOTAL
1006	3	0.00	26.44	0.00	0.00	0.00
1008	3	0.00	26.44	0.00	0.00	0.00
1004	3	0.00	26.44	0.00	0.00	0.00
1009	3	0.00	26.44	0.00	0.00	0.00
1007	3	0.00	26.44	0.00	0.00	0.00
1002	3	0.00	26.44	0.00	0.00	0.00
1005	2	57.01	57.01	100.43	100.58	1.96
1010	2	0.00	26.44	0.00	0.00	0.00
1008	2	0.00	26.44	0.00	0.00	0.00
1004	2	0.00	26.44	0.00	0.00	0.00
1009	2	0.00	26.44	0.00	0.00	0.00
1007	2	0.00	26.44	0.00	0.00	0.00
1002	2	0.00	26.44	0.00	0.00	0.00
1005	1	58.97	58.94	101.86	101.55	1.95
1010	1	0.00	26.44	0.00	0.00	0.00
TENTATIVE TRACK 4 CORRELATED AT 23.75 SECONDS ON RADAR 1						
1008	1	0.00	26.44	0.00	0.00	0.00
1009	1	0.00	26.44	0.00	0.00	0.00
1009	1	0.00	26.44	0.00	0.00	0.00
TENTATIVE TRACK 7 CORRELATED AT 23.90 SECONDS ON RADAR 1						
1002	1	0.00	26.44	0.00	0.00	0.00
1010	3	0.00	26.44	0.00	0.00	0.00
1005	3	55.80	55.82	100.78	102.03	1.85
TENTATIVE TRACK 5 CORRELATED TO FIRM TRACK AT 26.40 SECONDS						
1008	3	0.00	26.44	0.00	0.00	0.00
1004	3	0.00	26.44	0.00	0.00	0.00
1011	3	0.00	26.44	0.00	0.00	0.00
1009	3	0.00	26.44	0.00	0.00	0.00
1002	3	0.00	26.44	0.00	0.00	0.00
TRACK 12 INITIATED RANGE = 33.92 AZIMUTH = 107.37 HEIGHT = 0.000 TIME = 23.84 ON RADAR 1						
TRACK 13 INITIATED RANGE = 33.53 AZIMUTH = 101.35 HEIGHT = 1.750 TIME = 26.41 ON RADAR 5						
1010	2	55.44	55.44	100.88	100.74	2.47
1013	2	0.00	26.44	0.00	0.00	0.00
1012	2	0.00	26.44	0.00	0.00	0.00
1008	2	0.00	26.44	0.00	0.00	0.00
1004	2	0.00	26.44	0.00	0.00	0.00
TRACK 14 INITIATED RANGE = 28.83 AZIMUTH = 97.52 HEIGHT = 1.230 TIME = 27.40 ON RADAR 2						
1011	2	0.00	26.44	0.00	0.00	0.00
1009	2	0.00	26.44	0.00	0.00	0.00
1002	2	0.00	26.44	0.00	0.00	0.00
5	1	58.02	58.01	101.02	100.71	0.00
1014	1	0.00	26.44	0.00	0.00	0.00

Fig. 2d - Level 3 printout

TRACK	SEAS. AZ.	HEAS. HGT	PRD. HGT	TIME	STANT	TOTAL
1009	1	0.00	26.44	0.00	0.00	0.00
TENTATIVE TRACK 3 CORRELATED AT 23.90 SECONDS ON RADAR 1						
1002	1	0.00	26.44	0.00	0.00	0.00
TRACK 11 INITIATED RANGE = 31.32 AZIMUTH = 107.37 HEIGHT = 0.000 TIME = 23.84 ON RADAR 1						
CLUTTER 41 CORRELATED AT 26.43 SECONDS ON RADAR 5						
DETECTION 74 ON RADAR 5 CORRELATES WITH CLUTTER 41						
CLUTTER 41 UPDATED 11.7684 11.7684 90.9274 26.2414 21.2414						
DETECTION 78 ON RADAR 5 CORRELATES WITH CLUTTER 41						
CLUTTER 41 UPDATED 10.8824 10.8824 95.9812 26.3292 21.3292						
DETECTION 80 ON RADAR 5 CORRELATES WITH CLUTTER 10						
CLUTTER 10 UPDATED 11.8650 11.8650 101.1134 26.3814 21.3814						
DETECTION 80 ON RADAR 5 CORRELATES WITH CLUTTER 8						
CLUTTER 8 UPDATED 8.8500 8.8500 100.9031 100.4074 26.4074 21.4074						
1010	1	0.00	26.44	0.00	0.00	0.00
1005	1	55.80	55.82	100.78	102.03	1.85
TENTATIVE TRACK 5 CORRELATED TO FIRM TRACK AT 26.40 SECONDS						
1008	3	0.00	26.44	0.00	0.00	0.00
1004	3	0.00	26.44	0.00	0.00	0.00
1011	3	0.00	26.44	0.00	0.00	0.00
1009	3	0.00	26.44	0.00	0.00	0.00
1002	3	0.00	26.44	0.00	0.00	0.00
TRACK 12 INITIATED RANGE = 33.92 AZIMUTH = 107.37 HEIGHT = 0.000 TIME = 23.84 ON RADAR 1						
TRACK 13 INITIATED RANGE = 33.53 AZIMUTH = 101.35 HEIGHT = 1.750 TIME = 26.41 ON RADAR 5						
DETECTION 67 ON RADAR 2 CORRELATES WITH CLUTTER 12						
CLUTTER 12 UPDATED 11.7684 11.7684 91.2374 27.4094 21.4094						
CLUTTER 54 CORRELATED AT 27.66 SECONDS ON RADAR 2						
DETECTION 68 ON RADAR 2 CORRELATES WITH CLUTTER 11						
CLUTTER 11 UPDATED 10.8824 10.8824 95.9812 27.0016 21.9016						
DETECTION 72 ON RADAR 2 CORRELATES WITH CLUTTER 15						
CLUTTER 15 UPDATED 11.8650 11.8650 101.1134 27.5304 22.0304						
DETECTION 71 ON RADAR 2 CORRELATES WITH CLUTTER 13						
CLUTTER 13 UPDATED 8.8500 8.8500 100.9104 100.4211 27.5427 22.0427						
5	2	55.44	55.44	100.88	100.74	2.47
1010	2	0.00	26.44	0.00	0.00	0.00
1013	2	0.00	26.44	0.00	0.00	0.00
1012	2	0.00	26.44	0.00	0.00	0.00
1008	2	0.00	26.44	0.00	0.00	0.00
1004	2	0.00	26.44	0.00	0.00	0.00
TRACK 14 INITIATED RANGE = 28.83 AZIMUTH = 97.52 HEIGHT = 1.230 TIME = 27.40 ON RADAR 2						
1011	2	0.00	26.44	0.00	0.00	0.00

Fig. 2e - Level 4 printout

## FUTURE DEVELOPMENTS

### Anticlutter and ECM Techniques

In an operational ADIT system, a desirable feature would be a method of controlling clutter or ECM false alarms in the detector through feedback from the tracking system. One method of implementing this would be to maintain a false-alarm map of the area covered by each radar. This map would consist of the number of false alarms in each small region in the area. The number of false alarms would be determined by the tracking program, possibly simply by counting the number of detections which do not correlate with any track or fixed clutter point. This map could then be used to raise or lower the detection thresholds of each radar. The present program is not real time. However, because part of the detection data from the SURDET program is the signal-to-noise ratio of each detection, the method described could be evaluated by a postdetection filtering of the detection file. This filtering would approximate an increased threshold by deleting detections with low signal-to-noise ratios.

### Initiation

As discussed earlier, a simple initiation scheme can degrade the track file in a dense detection environment. These detections could be false alarms or valid detections on a multitarget raid. In any case, with no a-priori knowledge of target motion, large correlation regions are necessary to allow for target motion. This allows false correlations to generate tracks on random false alarms or to confuse targets and generate spurious velocities in a raid environment.

One possible candidate system would operate as follows: The system would be a separate subprogram, divorced from the track correlation and updating. The uncorrelated detections remaining in the files after the correlation process would be saved by scan and sector in a separate file. An uncorrelated detection in the current scan of the area would trigger a trajectory-generation event. This event would attempt to associate detections from the last  $n$  scans with a straight-line trajectory. (An attempt to initiate on a maneuvering target in the presence of false alarms and missed detections would require too much time—real time, not computation time—to be feasible.) There would be allowed at most  $m$  missed detections. Because of the need to identify tracks quickly,  $n$  and  $m$  would be a function of the number of opportunities to detect the hypothetical trajectory in a given amount of time. One implementation of this process would be to fit a straight line to each collection of detections (each detection from the appropriate scan) and calculate a root-mean-squared normalized error (normalized by measurement variance, averaged over the number of detections used) and compare this value to a threshold. The collection with smallest error (less than the threshold) would be declared a track. The detections used would be deleted from the files. As the number of detections per scan and the number of scans increase, the number of collections increase binomially with  $m$  and  $n$ . A simpler method would be to fix  $m$  and  $n$  as 3 out of 4 detections, generate straight lines from the current detection to each detection in the first scan, and search the detections in the intervening two scans for a closest detection which is sufficiently close. This would be declared a track, and the detections would be removed from the files. Any detection more than 4 scans in the past would be discarded as a false alarm. Due to the large



measurement variances in azimuth and elevation, this process would probably consider only range and time of detection.

An example of the geometry of this process is shown in Fig. 3, where detections are located in a range-time coordinate system by a number indicating in which scan they occurred. As shown in the diagram, trajectory A would be declared a track on the basis of the detections of scans 1, 2, and 4, but an extra correlation step would be necessary to eliminate the detection of scan 3, which evidently is a detection of this target, from the files. Trajectory B would be declared a track. Trajectory C does not have an intermediate detection close enough to declare it a track. The dashed line D would not even be a candidate trajectory; however, if it is detected on either of the next two scans, it would then be declared a track. This process would be repeated with each of the other detections of scan 4. We see from dashed line E that possibly an inferior track has been established due solely to the order in which the detections of scan 4 were processed. To avoid this situation would greatly complicate the process, and there is still the likelihood, as in case D, that a track would still be established on the next two scans. The problem of the possibly erroneous track established by trajectory B could be solved by establishing tentative tracks from these trajectories and requiring additional confirmation before promoting these tracks to firm tracks.

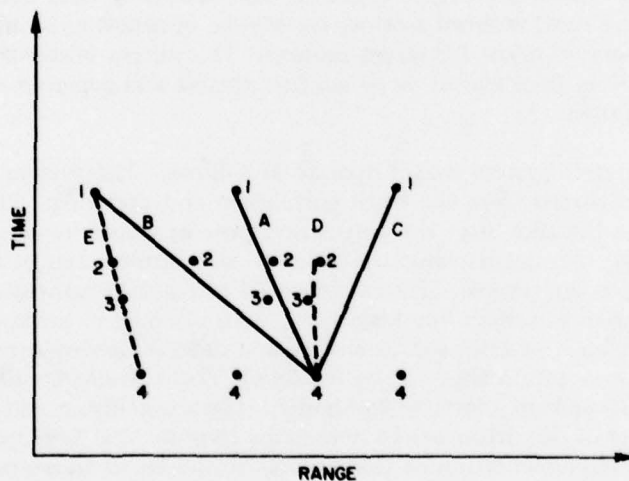

Fig. 3 - Example of initiation geometry

### Correlation

A problem with any simple correlation technique is that of wrong associations in a dense detection environment. If the correlation technique is to obtain a track and associate the track with the nearest detection, a missed detection can cause the track to be updated with a detection closer to another track and in fact derived from that track. Conversely, if a detection is obtained and associated with the nearest track, a false alarm

(or even an initial detection of a new track) can update a track which has been detected and whose detection is closer to the track than the false alarm. A more sophisticated correlation scheme is desirable. One such technique has been described in the section "Track Correlation and Updating" involving multiple nested correlation regions. This is a "discrete" process to correlate tracks to detections and then detections to tracks. This process can lead to error if, for example, two tracks A and B are given with one detection closer to B than A and track A is processed first. If the detection lies in the  $i$ th correlation region of B and in the  $(i + 1)$ th correlation region of A, then the detection will be flagged as being closer to B and track A will not be updated; eventually the detection will be used to update track B. If the detection lies in the  $i$ th correlation region of both A and B, then the first track considered, A, will be updated. A correlation scheme used by the Applied Physics Laboratory is a "continuous" process in which a list is made of tracks due to be updated [9]. Associated with each track is a list of detections that correlate with the track and the corresponding statistical distance between each detection and track. The detection with smallest statistical distance is found and used to update the corresponding track. That track and detection are eliminated from the lists, and the next-smallest statistical distance is found. This process is continued until either the tracks or detections are exhausted. One modification to either of the above two correlation schemes is simple to discriminate against tentative tracks in favor of firm tracks. This modification would multiply each component (range or azimuth) of the correlation error (the difference between track position and detection position) for tentative tracks by an "expansion" factor (such as 1.25). For the "continuous" correlation, detections correlating with both a firm track and a tentative track are more likely to be used to update the firm track. For the "discrete" correlator, detections whose distance from a tentative track is more than 80% of the  $i$ th correlation size would not correlate until the  $(i + 1)$ th correlation region.

An important problem as yet unaddressed by any tracking system because of its complexity is illustrated in Fig. 4. Given tracks A, B, and C and detections 1, 2, and 3, the list technique would update C with 2 and B with 3, leave A unupdated, and interpret 1 as a false alarm or initial detection of a new track. The question is whether this is the most reasonable assessment of the situation or whether it is more reasonable to assume that A correlates with 3, B correlates with 2, and C correlates with 1 and that there are no false alarms or missed detections. This question can be answered using maximum-likelihood techniques in which each combination of tracks and detections is considered and its likelihood calculated based on the probability of the measurement error observed, probability of false alarms required, probability of missing detections, probability of a new track being detected for the first time, and even an estimate of the probability of a target maneuver occurring at this time. This method of solution would entail much more computing time than is normally available in an operational system but may be of interest as an evaluation tool in determining which feasible correlation techniques approach this optimal level.

### Filtering

The simplest improvement to the decreasing-bandwidth filter described in the section "Tracking Filter" would be to implement the adaptive-bandwidth filter used in an earlier version of ADIT. This filter was not discarded for any shortcoming but in the interest

of conserving space in the central memory of the minicomputer. This filter is described in Ref. 4 and in greater detail in Ref. 10. The principle of this filter is to set the filter bandwidth by the magnitude of the correlation between the difference between measured and predicted position on the current update and the difference on the preceding update. If the track carried in the computer closely approximates the true trajectory of the target, then the measured position would be random about the predicted position, the correlation would be small, and the bandwidth should be correspondingly small and smooth the track heavily. If the track is not the true trajectory, due to a maneuver for example, the measured position would be consistently displaced relative to the predicted position, causing an increased correlation. This would increase the bandwidth, placing more weight on the measurements, and allow the filter to follow the target through the maneuver.

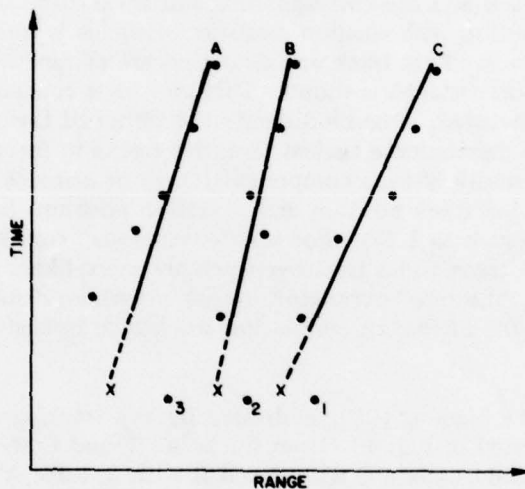

Fig. 4 - Example of correlation ambiguities

Another possibility for improving the filter would be to implement a Kalman filter with either a turn detector or an adaptive bandwidth as described above.

Whatever else is done with the filter, the necessity exists for tracking in a rectilinear (xy) coordinate system at short ranges (less than 20 n.mi.).

#### Software Stabilization

Naval radars generally are unstabilized: the antenna shares the motion of the platform. A 3D radar can be electronically stabilized; that is, if the location of the target in the deckplane coordinates and the orientation of the deckplane are known, the coordinates of the target in a stabilized coordinate system can be calculated. This is not possible with a 2D radar, because the elevation of the target is not known and the measured azimuth of the target is a function of the elevation. However, in an integrated

tracking system which includes 2D and 3D radars, the elevation information can be supplied by the 3D radar whenever one is able to correlate the unstabilized 2D detection with a 3D track. One will then be able to stabilize the 2D information before using it to update the track or even before correlation is attempted. This process requires knowledge of the platform orientation. This information is available in data generated by the SURDET radar simulation model.

An even more interesting problem is an integrated tracker involving only unstabilized 2D radars. By assuming a straight target trajectory, the deviations of the measured azimuth from the smoothed azimuth at different platform orientations would yield a gross estimate of target elevation.

#### SUMMARY

The MERIT system as currently implemented is suitable (in conjunction with the SURDET program) for evaluating automatic tracking by proposed or existing radars. The radars can be considered individually or as members of a radar suite. Important characteristics of the radars are accuracy of measurement, probability of detection, and probability of false alarm. With a-priori knowledge of the target scenario and environment, the MERIT system can examine the effect of these radar characteristics on a tracking system. Effects which may be observed are: gross track inaccuracy or track confusion due to poor detection accuracy, loss of track due to poor probability of detection, or saturation of the system or generation of false tracks due to excessive false alarms.

The MERIT system may also serve as an investigative tool in evaluating the cost of various improvements and the effect of the improvement from the viewpoint of track quality. The improvements currently being considered are: improved initiation, advanced correlation techniques, automatic radar control in adverse environments, optimal realizable tracking filters, and software stabilization of 2D radars. As the body of information increases with the operation of MERIT with various radar systems in various threat scenarios, new problems may be identified and new solutions be suggested for evaluation.

J.D. WILSON

REFERENCES

1. G.V. Trunk, B.H. Cantrell, and F.D. Queen, "Basic System Concept for Integrating a 2D and a 3D Radar and Designs of Automatic Detection System," NRL Report 7678, Mar. 7, 1974 (AD 777959).
2. B.H. Cantrell, G.V. Trunk, and J.D. Wilson, "Tracking System for Two Asynchronously Scanning Radars," NRL Report 7841, Dec. 5, 1974 (AD A002927).
3. B.H. Cantrell, G.V. Trunk, F.D. Queen, J.D. Wilson, and J.J. Alter, "Automatic Detection and Integrated Tracking System," Int. Radar Conf. Rec., Apr. 1975, pp. 391-395.
4. J.D. Wilson and B.H. Cantrell, "Tracking System for Asynchronously Scanning Radars With New Correlation Techniques and an Adaptive Filter," NRL Report 7952, Jan. 14, 1976 (AD A020540).
5. G.V. Trunk, J.D. Wilson, B.H. Cantrell, J.J. Alter and F.D. Queen, "Modifications to an Preliminary Results for the ADIT System," NRL Report 8091, April 19, 1977 (AD A039799).
6. "Program Performance Specification for an AN/SYS-1 Detector/Tracker Sub-System of the DDG2/15 Combat Weapon System," Johns Hopkins University, Applied Physics Laboratory XWS-15612, Aug. 1975.
7. L.C. Davis and G.V. Trunk, "Surveillance Radar Detection (SURDET) Program," NRL Report 8228, in preparation.
8. K.E. Richeson, "Fleet Systems Report, Radar Detection System Software," John Hopkins University, Applied Physics Laboratory SMS-FS-513, MWD-2-351, Nov. 1971.
9. G.V. Trunk, "Survey of Radar Signal Processing," NRL Report 8117, June 21, 1977.
10. B.H. Cantrell, "Adaptive Tracking Algorithm," NRL Memorandum Report 3037, Apr. 1975 (AD A011122).