

AD-A055 764

IIT RESEARCH INST CHICAGO ILL  
SURVIVABILITY IN CRISIS UPGRADED SHELTERS. (U)  
FEB 78 A LONGINOW  
IITRI-J6390-F

F/G 13/13

UNCLASSIFIED

DCPA01-76-C-0321

NL

1 OF 2  
ADA  
055764

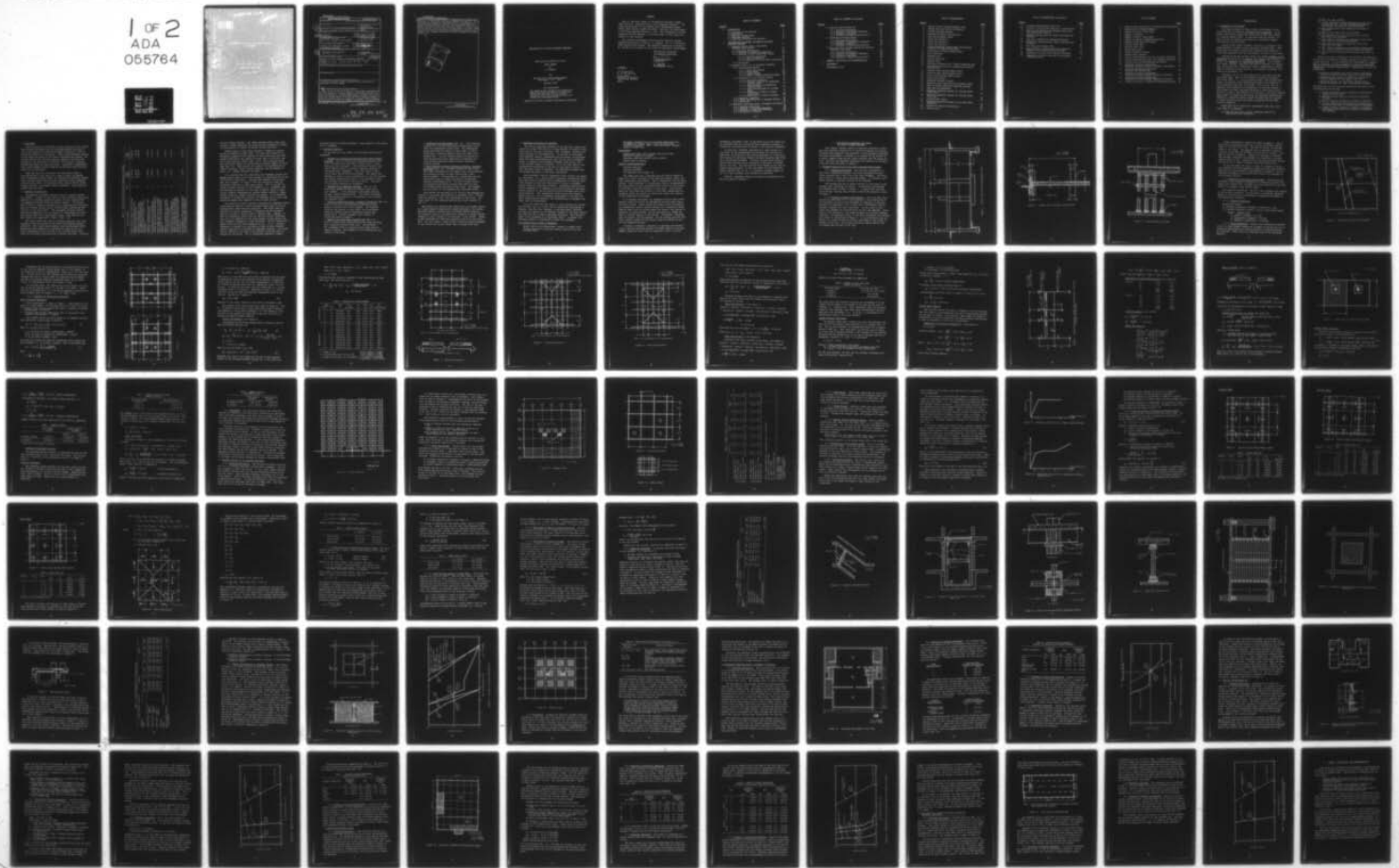

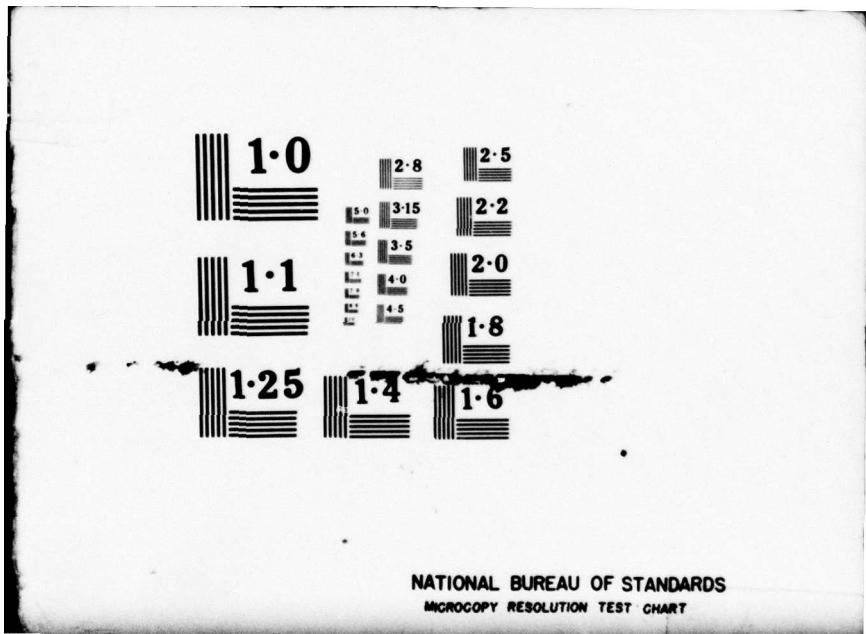

NATIONAL BUREAU OF STANDARDS  
MICROCOPY RESOLUTION TEST CHART



FOR FURTHER TRAN ~~SM~~

~~SECRET~~  
11

February 1978

AD A 055764



SURVIVABILITY IN CRISIS UPGRADED SHELTERS  
FINAL REPORT

AD No. ~~SECRET~~  
DDG FILE COPY

Contract DCPA01-76-C-0321  
DCPA Work Unit 1519B

February 1978

DDC  
RECEIVED  
JAN 27 1978  
RESISTIVE  
F

Approved for public release; Distribution unlimited.

UNCLASSIFIED

SECURITY CLASSIFICATION OF THIS PAGE (When Data Entered)

REPORT DOCUMENTATION PAGE		READ INSTRUCTIONS BEFORE COMPLETING FORM
1. REPORT NUMBER	2. GOVT ACCESSION NO.	3. RECIPIENT'S CATALOG NUMBER
4. TITLE (and Subtitle) <b>SURVIVABILITY IN CRISIS UPGRADED SHELTERS.</b>		5. TYPE OF REPORT & PERIOD COVERED Final Report 8/9/76 to 2/9/78
7. AUTHOR(s) A./ Longinow		6. PERFORMING ORG. REPORT NUMBER J6390
9. PERFORMING ORGANIZATION NAME AND ADDRESS IIT Research Institute 10 W. 35 St., Chicago, Illinois 60616		8. CONTRACT OR GRANT NUMBER(s) DCPA01-76-C-0321
11. CONTROLLING OFFICE NAME AND ADDRESS Defense Civil Preparedness Agency Washington, D.C. 20301		10. PROGRAM ELEMENT PROJECT, TASK AREA & WORK UNIT NUMBERS Work Unit 1619B
14. MONITORING AGENCY NAME & ADDRESS (if different from Controlling Office) IITRI-J6390-F		12. REPORT DATE February 1978
16. DISTRIBUTION STATEMENT (of this Report) Approved for public release; Distribution unlimited. Final rept. 9 Aug 76 - 9 Feb 78		13. NUMBER OF PAGES 101
17. DISTRIBUTION STATEMENT (of the abstract entered in Block 20, if different from Report)		15. SECURITY CLASS. (of this report) Unclassified
18. SUPPLEMENTARY NOTES		15a. DECLASSIFICATION DOWNGRADING SCHEDULE
19. KEY WORDS (Continue on reverse side if necessary and identify by block number) Civil Defense, Nuclear Weapons, Personnel Shelter, Blast Effects, Casualties, Survivors, Damage		
20. ABSTRACT (Continue on reverse side if necessary and identify by block number) This report contains the results of a study aimed at exploring the sheltering potential for people remaining in high risk areas when such areas are subjected to a nuclear weapon attack. Basements of six conventional buildings are evaluated when subjected to direct effects of a large yield nuclear weapon. On the basis of this evaluation probabilities of survival for shelter occupants are assigned. The six basements are subsequently upgraded using expedient measures and reevaluated		

DD FORM 1 JAN 73 1473 EDITION OF 1 NOV 65 IS OBSOLETE

UNCLASSIFIED

SECURITY CLASSIFICATION OF THIS PAGE (When Data Entered)

78 06 26 037  
175 350 LB



UNCLASSIFIED

SECURITY CLASSIFICATION OF THIS PAGE(When Data Entered)

subject to the same attack condition. Probabilities of survival for shelterees in conventional and upgraded basements are compared. It is concluded that basements in high risk areas can be upgraded using expedient methods to achieve a median lethal overpressure (MLOP) of at least 26 psi (179.26 kPa) from a large yield weapon. The level of protection achieved in any one case is a strong function of several parameters such as type of structure being considered for upgrading, size of shelter, time, equipment, materials, and labor available for implementation.

4

ACCESSION for	
NTIS	White Section <input checked="" type="checkbox"/>
DDC	Buff Section <input type="checkbox"/>
UNANNOUNCED	<input type="checkbox"/>
JUSTIFICATION	<input type="checkbox"/>
BY	
DISTRIBUTION/AVAILABILITY CODES	
Dist.	SP. CIAL
A	

UNCLASSIFIED

SECURITY CLASSIFICATION OF THIS PAGE(When Data Entered)

SURVIVABILITY IN CRISIS UPGRADED SHELTERS

DCPA Contract DCPA01-76-C-0321

FINAL REPORT

by

A. Longinow

for

Defense Civil Preparedness Agency  
Washington, D.C. 20301

February 1978

DCPA REVIEW NOTICE

This report has been reviewed in the Defense Civil Preparedness Agency and approved for publication. Approval does not signify that the contents necessarily reflect the views and policies of the Defense Civil Preparedness Agency.

Approved for public release; Distribution unlimited.

## PREFACE

This is the final report on IIT Research Institute (IITRI) J6390 entitled, "Survivability in Crisis Upgraded Shelters". The study was performed for the Defense Civil Preparedness Agency (DCPA) under Contract DCPA01-76-C-0321. Work was initiated August 9, 1976 and completed February 9, 1978. The technology on initial radiation has been updated, so the data shown in this report are subject to some question.

The study was performed in the Structural Analysis Section, Engineering Division of IITRI by A. Longinow. Mr. D. A. Bettge of DCPA monitored the program. The numerous suggestions provided by Mr. Bettge in the course of this study are gratefully acknowledged.

Respectfully Submitted,  
IIT RESEARCH INSTITUTE

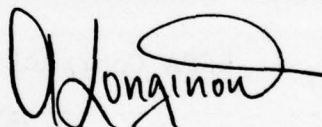

A. Longinow  
Engineering Advisor

APPROVED:

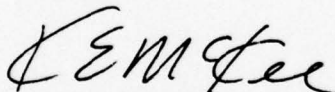

K. E. McKee  
Director of Research  
Engineering Division

AL/al



## TABLE OF CONTENTS

<u>Chapter</u>	<u>Page</u>
1. INTRODUCTION	1
1.1 Statement of the Problem	1
1.2 Risk Areas	3
1.3 Shelters in Risk Areas	3
1.4 Personnel Shelters	6
1.5 Upgrading Techniques for Shelters	8
2. SURVIVABILITY ESTIMATES FOR PEOPLE IN CRISIS UPGRADED SHELTERS	11
2.1 Basement Shelter With a Flat Plate Overhead Floor System	11
2.1.1 Building Description	11
2.1.2 Estimate of People Survivability	11
2.1.3 Analysis of Flat Plate Floor System	15
2.1.3.1 Material Properties	15
2.1.3.2 Basic Assumptions	15
2.1.3.3 Analysis of the As-Built Structure	17
2.1.4 Discussion	33
2.2 Basement Shelter in an Apartment Building	33
2.2.1 Building Description	33
2.2.1.1 Floor Slab Design	35
2.2.1.2 Beam Design	39
2.2.1.3 Column Design	39
2.2.1.4 Beam to Column Connection Design	39
2.2.2 Evaluation of the As-Built System	39
2.2.2.1 Structural Analysis	39
2.2.2.2 Flexural Capacity of Reinforced Concrete Slabs	42
2.2.2.3 Shear Capacity of Reinforced Concrete Slabs	48
2.2.2.4 Load Carrying Capacity of Edge Beams	49
2.2.2.5 Resistance of Beam to Column Connections	50
2.2.2.6 Resistance of Interior Columns	50
2.2.3 Expedient Upgrading	51
2.2.4 People Survivability in Basement Shelter	61
2.2.5 Discussion	64
2.3 Emergency Operating Center; Livermore, California	66
2.3.1 Building Description	66
2.3.2 Analysis of Building Components	68
2.3.3 Estimate of People Survivability	69
2.3.4 Discussion of Results	69

TABLE OF CONTENTS (concluded)

<u>Chapter</u>	<u>Page</u>
2.4 Hamilton AFB Building 424	71
2.4.1 Building Description	71
2.4.2 Analysis of Building Components	73
2.4.3 Expedient Upgrading	74
2.4.4 Estimate of People Survivability	76
2.5 Middlefield Parking Garage	76
2.5.1 Building Description	76
2.5.2 Analysis of Structural Components	79
2.5.3 Expedient Upgrading	79
2.5.4 Estimate of People Survivability	80
2.6 West Pavilion, Stanford University Hospital, Stanford, California	82
2.6.1 Building Description	82
2.6.2 Analysis of Basement Components	83
2.6.3 Expedient Upgrading	84
2.6.4 Estimate of People Survivability	84
3. SUMMARY, CONCLUSIONS AND RECOMMENDATIONS	86
4. REFERENCES	96
DISTRIBUTION LIST	99

## LIST OF ILLUSTRATIONS

<u>Figure</u>	<u>Page</u>
1. Typical Section Through Basement Area	12
2. Typical Wall and Slab Cross Section	13
3. Column Upgrading Concept	14
4. Estimate of People Survivability	16
5. Slab Reinforcement Layout	18
6. Yield Line Pattern 1	21
7. Yield Line Pattern 2	22
8. Yield Line Pattern 3	23
9. Assumed Equivalent Rigid Frame Representing a Section Through The Building	27
10. Definition of Column Loading Terms	30
11. Front Elevation	34
12. Basement Plan	36
13. Typical Slab Plan	37
14. Typical Panel	37
15. Resistance Function for a Simply Supported Beam	41
16. Resistance Function for a Reinforced Concrete Two-Way Slab	41
17. Interior Panel Reinforcement Layout	43
18. Exterior Panel Reinforcement Layout	44
19. Corner Panel Reinforcement Layout	45
20. Slab Yield Pattern	46
21. Expedient Basement Closure	53
22. Expedient Blast Protection for Elevator Shaft	54
23. Beam to Column Connection Upgrading Concept	55
24. Edge Beam Strengthening	56
25. Expedient Upgrading Concept for Two-Way Slabs (Side View)	57
26. Expedient Upgrading Concept for Two-Way Slabs (Top View)	58
27. Reinforcement Layout	59
28. Expedient Upgrading Concept for Two-Way Slabs (Modified)	62
29. Estimate of People Survivability	63
30. Shelter Areas	64



LIST OF ILLUSTRATIONS (concluded)

<u>Figure</u>		<u>Page</u>
31.	Livermore EOC Basement Floor Plan	67
32.	Estimate of People Survivability; Livermore EOC	70
33.	Hamilton AFB Building 424 Basement Floor Plan and Typical Wall Section	72
34.	Hamilton AFB Building 424 People Survivability Estimate	75
35.	Plan View, Middlefield Underground Garage	77
36.	Middlefield Parking Garage People Survivability Estimate	81
37.	West Pavilion Basement Plan	83
38.	West Pavilion, Stanford University Hospital, Basement People Survivability Estimate	85
39.	Comparison of People Survivability Estimates	93
40.	Comparison of People Survivability Estimates (Average Values)	94

## LIST OF TABLES

	<u>Page</u>
1. Relative Blast Protection in Conventional Structures	4
2. Computation of Ultimate Moments	20
3. Summary of Static Yield Loads	25
4. Summary of Results	31
5. Summary of Static Yield Loads	32
6. Summary of Results (Upgraded Structure)	33
7. Summary of Two-Way Slab Designs	38
8. Interior Panel Data	43
9. Exterior Panel Data	44
10. Corner Panel Data	45
11. Dynamic Flexural Capacity	48
12. Dynamic Shear Capacity	49
13. Failure Overpressures (psi) for As-Built Structure	52
14. Failure Overpressures (psi) for Upgraded Structure	60
15. Design Live Load and Building Use Classes	65
16. Predicted Collapse Overpressure Emergency Operating Center; Livermore, California	69
17. Predicted Collapse Overpressure Hamilton AFB Building 424	76
18. Predicted Collapse Overpressure Middlefield Parking Garage (As-built Structure)	79
19. Predicted Collapse Overpressure Middlefield Parking Garage (Upgraded Structure)	80
20. Percent Survivors at Indicated Overpressure Levels	92

## 1. INTRODUCTION

### 1.1 Statement of the Problem

The primary concern in United States civil defense is the short-term and the long-term survival of the population. At the present time various population centers are at-risk with respect to a nuclear weapon attack. At any given time and location the level of risk is variable and reaches its potentially highest level during a crisis period.

Current United States thinking, relative to a national civil defense posture, includes crisis relocation planning (CRP). This would result in moving a significant fraction of the high risk urban area population into the surrounding low level of risk areas.

Problems facing CRP include orderly and speedy movement of the population and provision of adequate life support and continuity of society for displaced and undisplaced population. This includes food, water, shelter, sanitation and medical services, law enforcement, fire protection, command and control communications, maintenance of essential utility services, life support facilities, continuity of government, etc.

Obviously, not all of the people will or can leave the high risk urban areas. Many of the currently existing life support facilities (LSF), i.e., food processing plants, food storage warehouses, and medical supply manufacturing plants are located in or near potentially high risk urban areas. This is also true of numerous vital industries not immediately or directly related to life support but whose continued operation at some level of production is vital to the viability of the nation. This would include among others the materials processing and equipment manufacturing industries. Therefore certain groups of people will be required to remain behind to staff and operate designated LSF and other critical industries.

Before CRP can be effectively implemented, some basic questions need to be answered:

- (1) What LSF and other critical industries need to be maintained after evacuation?



- (2) Where are they located?
- (3) At what fraction of normal operation are they to be operated and what are the corresponding manpower requirements for operation and maintenance?
- (4) What transportation and communication network is required?
- (5) Where is the labor force to be housed?
- (6) What shelters at or near LSF and other critical facilities are available?
- (7) What level of protection is afforded by these shelters relative to anticipated attack?
- (8) What level of shelter is required in host (low level of risk) areas?
- (9) What level of protection is required in fringe areas i.e., areas in direct vicinity to high risk areas?
- (10) How can the sheltering and operating requirements be met?

Based on the above statement of the problem, the objective of the study reported was to produce answers to certain of the 10 listed questions. It was concerned with determining the survivability potential of people remaining in high risk areas when subjected to a nuclear weapon attack. Specifically, it was concerned with:

- reviewing techniques that may be used for upgrading shelters in high risk areas during the crisis period,
- determining the "people survivability" potential of shelters upgraded in this manner, and thus
- producing criteria for projecting "people survivability estimates" for high risk population centers.

The objectives of the study were achieved on the basis of the following work and services.

- (1) Review and analyze crisis upgrading techniques for shelters in risk areas.
- (2) Evaluate failure modes of structurally modified shelters.
- (3) Develop casualty estimates for people in shelters.
- (4) Utilize experimental data from blast tunnel tests and shock tube tests to describe failure mechanisms.
- (5) Project casualty estimates to impact on population remaining in risk areas as a function of overpressure exposure.

## 1.2 Risk Areas

The risk areas can be defined as those portions of the country which possess attributes such as providing defense and retaliation in the event of an attack and industry important to the recovery and viability of the nation. Since large population centers of this nation are hubs of the overall transportation network, and contain within their environs numerous industries and functions critical to the continuity and survival of the nation, then most metropolitan areas are high risk areas. Conversely, predominantly rural areas lacking critical industry and military facilities are lesser or low risk areas.

High risk areas for the nation are identified in Ref. 1. This publication is the result of a study in which the Defense Civil Preparedness Agency (DCPA) has analyzed the potential hazards from a nuclear weapon attack and has identified areas considered relatively more likely to experience direct weapon effects (blast, thermal radiation, and prompt nuclear radiation). Such areas are termed high risk areas.

## 1.3 Shelters in Risk Areas

Conventional buildings constitute the only current sheltering resource. Because of this they have been studied to gauge their potential in providing protection against fallout radiation and the immediate (direct) effects of nuclear weapons. The assessment of fallout radiation protection on a large-scale was initiated when the national fallout shelter identification program was carried out in the early 1960's. The assessment of direct effects protection capabilities for the purpose of identifying best available shelter space is of more recent origin. Some fairly up to date results are summarized in Table 1 (Ref. 2,3).

This table breaks the class of building structures into nine categories which are ranked in the order of decreasing inherent protection. The column labeled median lethal overpressure (MLOP) quantifies these categories of buildings in terms of the free field overpressure at the location of the building which would result in 50 percent fatalities and 50 percent survivors. Survivors

TABLE 1. RELATIVE BLAST PROTECTION IN CONVENTIONAL STRUCTURES

Structure Category	Code	MLOP psi (kPa)	MLOP psi (kPa)
1. Subway stations, tunnels, mines and caves	A	>35 (241.32)	>10 (68.95)
2. Basements and subbasements of massive (monumental) masonry buildings	B	10 (68.95)	7 (48.26)
3. Basements and subbasements of large, fully engineered structures having any floor system over the basement other than wood, concrete flat plate, or band beam support	C	10 (68.95)	7 (48.26)
4. Basements of wood frame and brick veneer structures including residences	D	10 (68.95)	4 (27.58)
5. First three stories of buildings with "strong" walls, less than 10 aboveground stories, and less than 50 percent apertures	E	8 (55.16)	2 (13.79)
6. Fourth through ninth stories of buildings with "strong" walls, less than 10 aboveground stories, and less than 50 percent apertures	F	8 (55.16)	2 (13.79)
7. Basements and subbasements of buildings with a flat plate or band beam supported floor system over the basement	G	5 (34.47)	2 (13.79)
8. First three stories of buildings with "strong" walls, less than 10 aboveground stories, and greater than 50 percent apertures; or first three stories of buildings with "weak" walls and less than 10 aboveground stories.	H	5 (34.47)	2 (13.79)
9. All aboveground stories of buildings having 10 or more stories. Fourth through ninth stories of buildings having "weak" walls.	I	5 (34.47)	2 (13.79)



include nonfatal injured. The column labeled median injury overpressure (MIOP) quantifies the given building categories in terms of overpressures to produce 50 percent injured survivors.

Results given in this table represent a summary of several people survivability studies (Ref. 4,5) which were backed by experimental programs on the response of full-scale walls and floor systems subjected to the effects of blast (Ref. 6,7,8,9,10), analytic floor and wall studies (Ref. 11,12), and a detailed field data collection effort on a statistically selected sample of buildings (Ref. 13). These results are based on the consideration of thermal radiation, prompt nuclear radiation, and the effects of blast, i.e., dynamic pressure and debris.

It is evident from this tabulation that basements provide the better shelter space if the first category is discounted due to its very distinct limitations. Although some basements can be quite weak (see category 7 in Table 1) the vast majority of them are nonetheless superior to upper story spaces. This is because the primary casualty producer in full basements (i.e., basements with few apertures in relation to its size) is debris, while in upper stories casualty mechanisms may include thermal radiation, prompt nuclear radiation, dynamic pressures and debris. It is therefore reasonable to assume that survivors in basements will include fewer injured personnel when compared to that of upper stories.

The selection of basic shelters considered for upgrading should intuitively be limited to those structures which prior to any upgrading effort offer the best protection. This would limit the selection to certain categories of basements and the procedure implicit in Table 1 could be used to identify them. However, it does not necessarily follow that all LSF and critical industries that are to be operated in risk areas during a crisis period will have "adequate" basements in their proximity. In fact certain geographic areas will not have basements at all. It is therefore important to consider all structures in terms of best available shelter space and as a function of geographic location. This study was not limited in its scope to any specific structure types or portions of structures. Due to limitations imposed by readily

available data on existing buildings, it was limited to the evaluation of basements.

#### 1.4 Personnel Shelters

In the course of this effort the following shelters were considered

1. Basement of a Reinforced Concrete "Flat Plate" Office Building. This is a four-story reinforced-concrete flat plate structure with reinforced concrete walls, a basement and a brick exterior. This building contains a personnel shelter which is located in specific portions of the ground floor (basement). The ground floor is partially above and partially below grade. The shelter was designed to resist a blast overpressure of 4 psi (27.58 kPa). This design overpressure applies to the peripheral walls, the overhead (flat plate) slab and closures. The walls of the shelter envelope are windowless.
2. Basement of an Apartment Building. This is a 10-story steel framed building with masonry walls and a full basement. It was designed in accordance with the Chicago, Illinois Building Code. This study considered the sheltering potential of the basement in its as-built and upgraded states.
3. Emergency Operating Center, Livermore, California (Ref. 14) This is a one-story load-bearing reinforced-concrete masonry structure with a full basement. The basement, which was the subject of this study, has a reinforced concrete overhead slab and reinforced concrete peripheral walls. Interior basement walls consist of reinforced concrete masonry.
4. Hamilton Air Force Base, Building 424 (Ref. 14) This is a three-story reinforced-concrete frame building with reinforced concrete floor slab. The building has a basement which is partially above grade and has numerous windows. The basement of this building was the subject of the study.



5. Middlefield Parking Garage (Ref. 14). This structure consists of a two-story wood frame building with street level and underground parking areas. The underground garage which was the subject of this study, is fully buried and is located primarily below the street level parking area. Its roof system consists of one-way reinforced concrete joists supported by reinforced concrete girders spanning between circular reinforced concrete columns.

6. West Pavilion, Stanford University Hospital, Stanford, California (Ref. 14). The West Pavilion is one of several wings extending from the central core of the hospital. The building consists of three stories and a fully buried basement. The building has a reinforced concrete frame with exterior columns and interior reinforced concrete load-bearing walls. The floor system consists of transverse reinforced concrete tube slabs but with solid slabs along transverse column lines. The basement was the subject of the upgrading and evaluation effort.

Each shelter was evaluated in its as-built and upgraded conditions to the extent made possible by available data. Collapse loads for shelters 1 and 2 were determined in this study. Collapse loads for the remaining shelters were those reported in Ref. 14.

Each shelter was analyzed when subjected to the prompt effects of a single megaton range nuclear weapon exploded at the surface. Pertinent effects included blast and prompt nuclear radiation. The procedure used for calculating the intensity of prompt nuclear radiation at the location of the structure is not current. Recent studies performed for DCPA have produced a more up to date procedure. For this reason, prompt nuclear radiation hazards estimated in this report may be more severe than is actually the case.

### 1.5 Upgrading Techniques for Shelters

The type of upgrading technique to be used with a given basic shelter in a high risk area is a strong function of several parameters such as the type of shelter, time, equipment, materials and labor available for implementation. If the task is preplanned with materials present, premeasured and prestocked, and equipment, power and labor prescheduled such that the job can be completed within a stipulated (and perhaps rehearsed) time period, then a very specific result is possible. If on the other hand no preplanning and prestocking of any kind is done then of course a very different result is expected. The difference between these two extreme approaches is obviously significant.

The anticipated time for upgrading (crisis period) can always be "stretched", i.e., better used by imposing a preplanning effort. This would involve identification (designation) of critical industries and LSF in risk areas followed by a survey to determine shelter needs for operating personnel. Designated shelters would then be examined as to adequacy in providing protection and habitability relative to the anticipated attack environment and crisis period duration. This examination (field survey and analysis) would result in a set of upgrading requirements on the basis of which prestocking of materials and prescheduling of equipment and labor could be accomplished.

If on the other hand the amount of time available for upgrading is short, say 2 to 3 days, and no substantial preplanning is possible, then the civil defender is laboring under a handicap and must rely heavily on the inherent strength of the basic shelter and effective use of simple upgrading techniques. Each structure needs to be considered on an individual basis. In general the following methods or combinations thereof are necessary.

#### For Overhead Floor System in Basements

Reduce spans by providing beams, columns or support walls  
Provide structural continuity between exterior walls and overhead floor

Strengthen overhead floor by providing additional reinforcement and topping (such as quick-setting fiber reinforced concrete). Note: This may require strengthening of columns also

#### Entranceways

Replace weak doors with stronger ones and provide additional supports at hinges

Introduce practical baffles where possible

Reduce size of openings

#### Interior Load-bearing Walls

Provide continuity

Increase thickness

Add pilasters and columns, etc.

The number and size of openings into the shelter should be reduced to a level consistent with reasonable egress, safety and other operational requirements. This is especially true for upper stories. Such reductions or eliminations could be accomplished by the installation of heavy prestocked steel plates or the closing of previously installed shelters or blast doors. Such actions would not only reduce the severity of the blast induced wind environment within the shelter but would also reduce the severity of the overpressure environment.

As a minimum requirement for upgrading shelters good "house-keeping" conditions should be implemented and maintained during the crisis period. These include the removal and/or securing of all nonessential objects (except perhaps for a completely closed shelter) which could be thrown around the shelter, the removal or taping of all glass windows, and the application of padded surfaces in certain regions of the shelter. Furthermore, depending upon the shelter size and geometry, and the opening size and locations, certain regions of the shelter should be marked off and not used whenever possible.

A review of available literature on upgrading and retrofitting of existing buildings against the prompt effects of nuclear weapons turned up little with the exception of Ref. 14 and 15.



Information contained in Ref. 14 was found to be very useful and was therefore used as a source for basic upgrading concepts in conjunction with guidelines discussed in the previous paragraphs.

As used here, expedient upgrading of a given shelter is a task which can be accomplished in accordance with previous instructions, by skilled or semi-skilled personnel in a relatively short period of time using readily available materials and little or no specialized equipment. "Previous instructions" would be manuals and training courses developed on the basis of studies such as this one. The time required would depend on the type of shelter being upgraded, its size and number of able-bodied personnel available for the job. A reasonable estimate appears to be 2 to 3 days assuming close proximity of materials.

Shelters, upgrading concepts and people survivability estimates are given in Chapter 2.

## 2. SURVIVABILITY ESTIMATES FOR PEOPLE IN CRISIS UPGRADED SHELTERS

This chapter contains results of analyses performed to determine the protective capabilities of certain categories of existing buildings when upgraded using expedient, crisis upgrading techniques. The hazard environment is assumed to be produced by the effects of a single, megaton range nuclear weapon exploded near the ground surface. Shelters and upgrading techniques were selected on the basis of ground rules discussed in Chapter 1.

### 2.1 Basement Shelter with a Flat Plate Overhead Floor System

2.1.1 Building Description - The structure considered is a four-story, reinforced concrete, flat plate building with reinforced concrete walls, and a full (one level) basement. The building is part of a large office building complex. It contains a personnel shelter in specific portions of the basement.

The building portion of direct interest to this study is the basement area containing the shelter. An elevation view through the basement area is shown in Figure 1. A typical wall and slab cross section, showing some pertinent construction details is given in Figure 2.

2.1.2 Estimate of People Survivability - Since the flat plate concept has been and still is quite popular in the construction of new buildings, and since such buildings are numerous, it was felt desirable to determine if this concept may be economically and expediently upgraded for blast resistance. In the course of this study this basement was evaluated both as-built and upgraded. Since shear at the periphery of the column produces the critical response condition, the upgrading concept is one which eliminates this problem. The concept is illustrated in Figure 3. In the particular case the effect is to shift the mode of failure from shear at the column to flexure of the slab. The casualty mechanism remains debris from the breakup and collapse of the slab.

1 ft = 0.3048m  
1 inch = 25.4mm

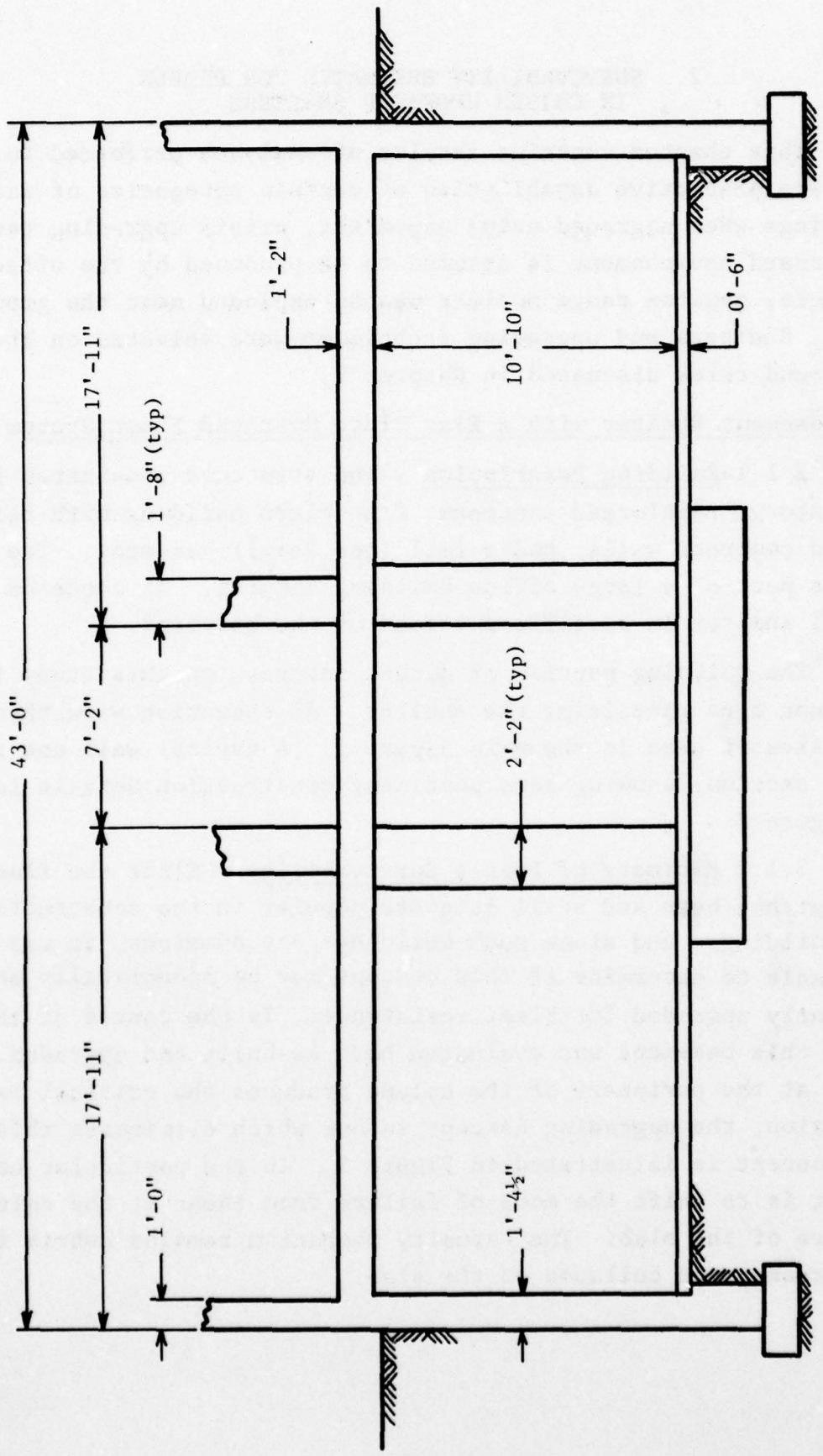

Figure 1. Typical Section Through Basement Area



1 ft = 0.3048m  
1 inch = 25.4mm

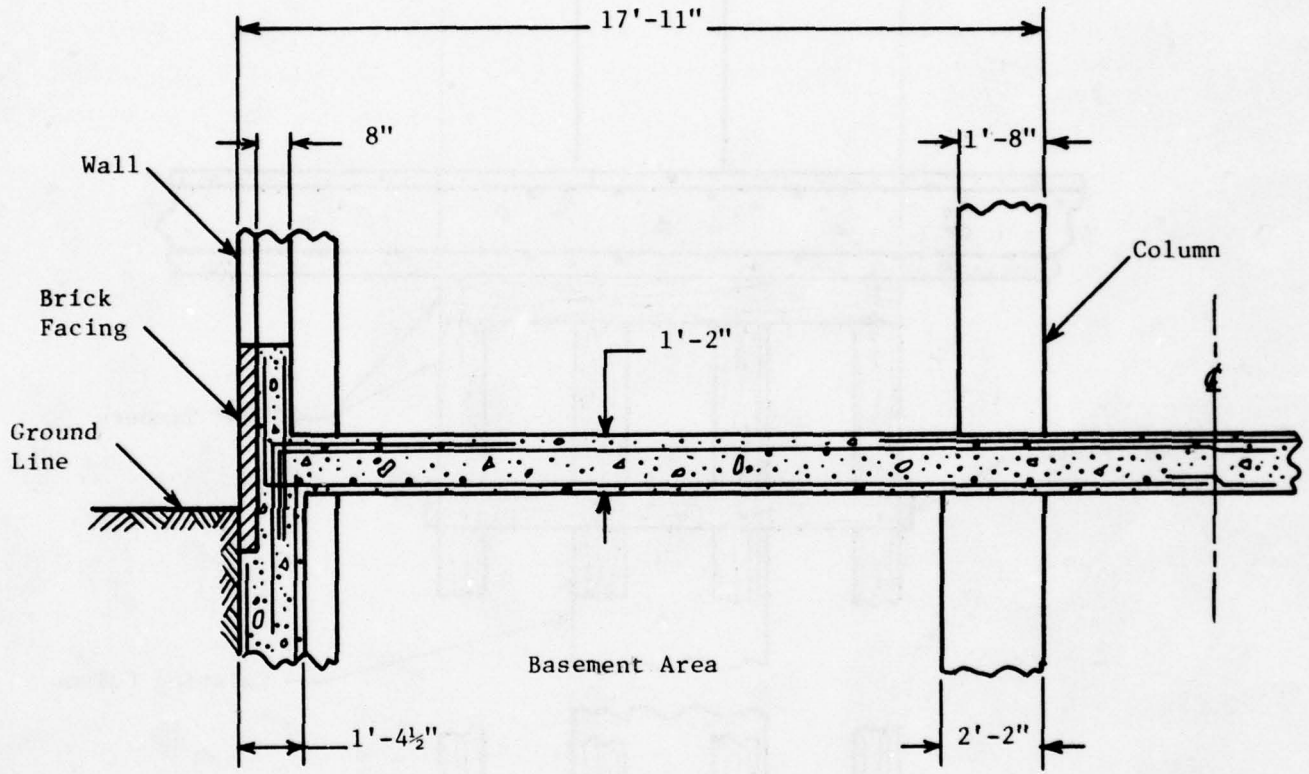

Figure 2. Typical Wall and Slab Cross Section

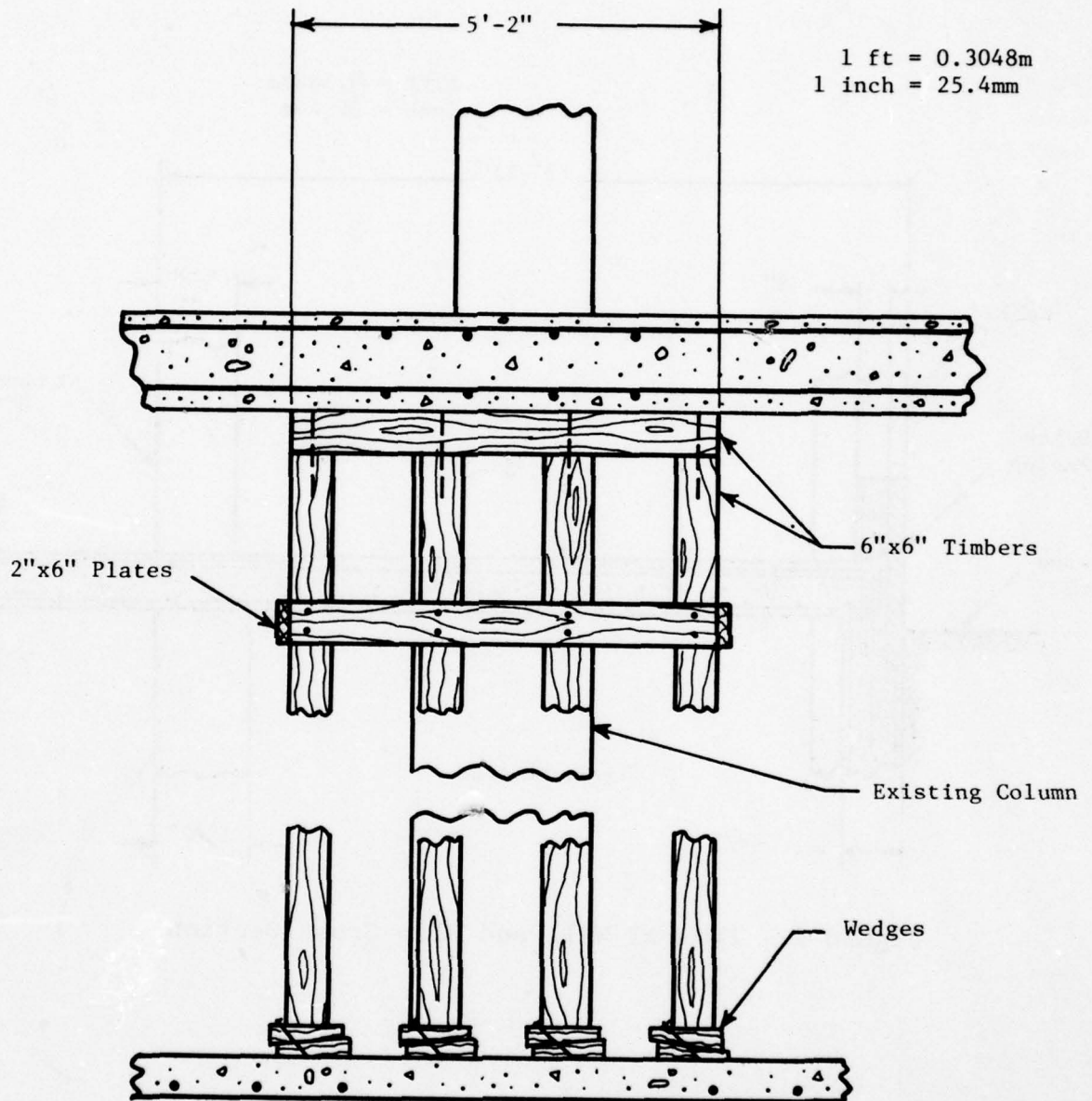

Figure 3. Column Upgrading Concept



People survivability results are shown in Figure 4. The as-built slab is expected to yield at 4.87 psi (33.58 kPa) and collapse at 7.61 psi (52.47 kPa). The mode of failure is punching shear at the column. The upgraded slab is expected to yield at 6.09 psi (41.99 kPa) and collapse at 10.66 psi (73.50 kPa). The mode of failure is flexural. Between the extremes of yielding and collapse, casualties are assumed to be produced by concrete spalled from the slab. Expedient blast closures preclude tumbling casualties due to dynamic pressures entering shelter areas.

If the area under the curve is taken as a measure of protection afforded, then this upgrading concept increases the protective capability of this basement by approximately 34 percent. All calculations performed in arriving at these results are included in the following sections.

2.1.3 Analysis of Flat Plate Floor System - Calculations are presented on the ultimate resistance of a reinforced concrete flat plate floor located over a basement area when subjected to the blast effects of a megaton range nuclear weapon.

Two cases are considered. The first case considers the response of the as-built structure. In the second, an expedient upgrading measure is used and the corresponding strengthening advantages of this measure are evaluated.

2.1.3.1 Material Properties:

Reinforced Concrete:

$f'_c$  (ultimate compressive strength of concrete) = 3 ksi

$f_y$  (ultimate strength of steel) = 40 ksi (intermediate grade)

Timber: Longleaf Pine

$f_t$  (tensile strength) = 9.3 ksi

$f_c$  (compressive strength) = 8.44 ksi

E (modulus of elasticity) = 1,990 ksi

2.1.3.2 Basic Assumptions: Based on the information contained in Ref. 16, under dynamic loading the strength of concrete may be increased by approximately 25 percent and that of reinforcing steel by 15 percent. These values are therefore used in the subsequent analysis.

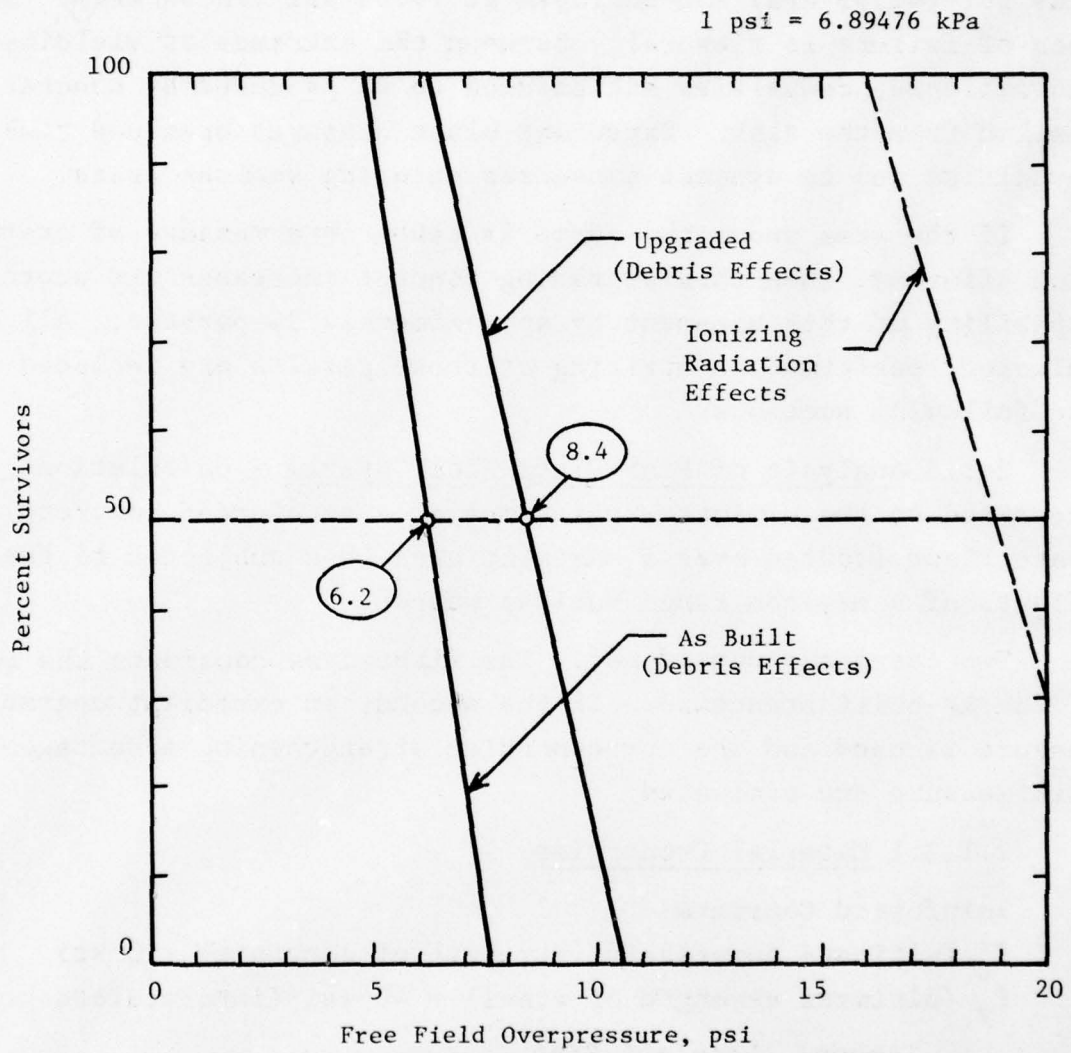

Figure 4. Estimate of People Survivability

Procedures for the design analysis of hardened structures such as the Corps of Engineers Design Manual (Ref. 17) for example, do not assume the use of an "undercapacity" factor of  $\phi = 0.9$  for flexure. In view of the fact that concrete may be under the specified strength but steel is rarely under the specified yield strength, and since the loading condition considered herein is not conventional, no undercapacity factor for flexure is used.

For punching shear, the capacity may be 60 percent to 85 percent of the ACI formula with  $\phi = 1$  (see Ref. 17, 18 and 19). Therefore the ACI formula with  $\phi = 0.85$  and no increase in concrete and steel strength shall be assumed, i.e.,  $4\phi \sqrt{f'_c} = V_u/bd$ .

### 2.1.3.3 Analysis of the As-built Structure:

#### Static Flexural Resistance

Slab reinforcement is shown in Figure 5. Since there are two layers of reinforcement, the following values of  $d$  and  $d'$  are used.  
 $d$  = distance from extreme compressions fiber to centroid of tension reinforcement = 12 inches.

$d'$  = distance from extreme compression fiber to centroid of compression reinforcement = 2 inches.

The ultimate design resisting moment for rectangular sections with compression reinforcement is given by

$$M_u = \phi \left[ (A_s - A'_s) f_y \left(d - \frac{a}{2}\right) + A'_s f_y (d - d') \right] \quad (1)$$

where  $a = (A_s - A'_s) f_y / 0.85 f'_c b$

$A_s$  is the area of tension reinforcement, (inch)<sup>2</sup>

$A'_s$  is the area of compression reinforcement, (inch)<sup>2</sup>

$b$  is the width of member, inch.

This equation is valid only when the compression steel reaches the yield strength,  $f_y$ , at ultimate strength. This is satisfied when

$$p - p' \geq 0.85 k_1 \frac{f'_c}{f_y} \frac{d'}{d} \frac{87,000}{87,000 - f_y} \quad (2)$$

where

$$p = \frac{A_s}{bd}, \quad p' = \frac{A'_s}{bd}$$



#5 bar has a diameter of 15.88mm  
 #6 bar has a diameter of 19.05mm  
 #7 bar has a diameter of 22.22mm

1 ft = 0.3048m  
 1 inch = 25.4mm

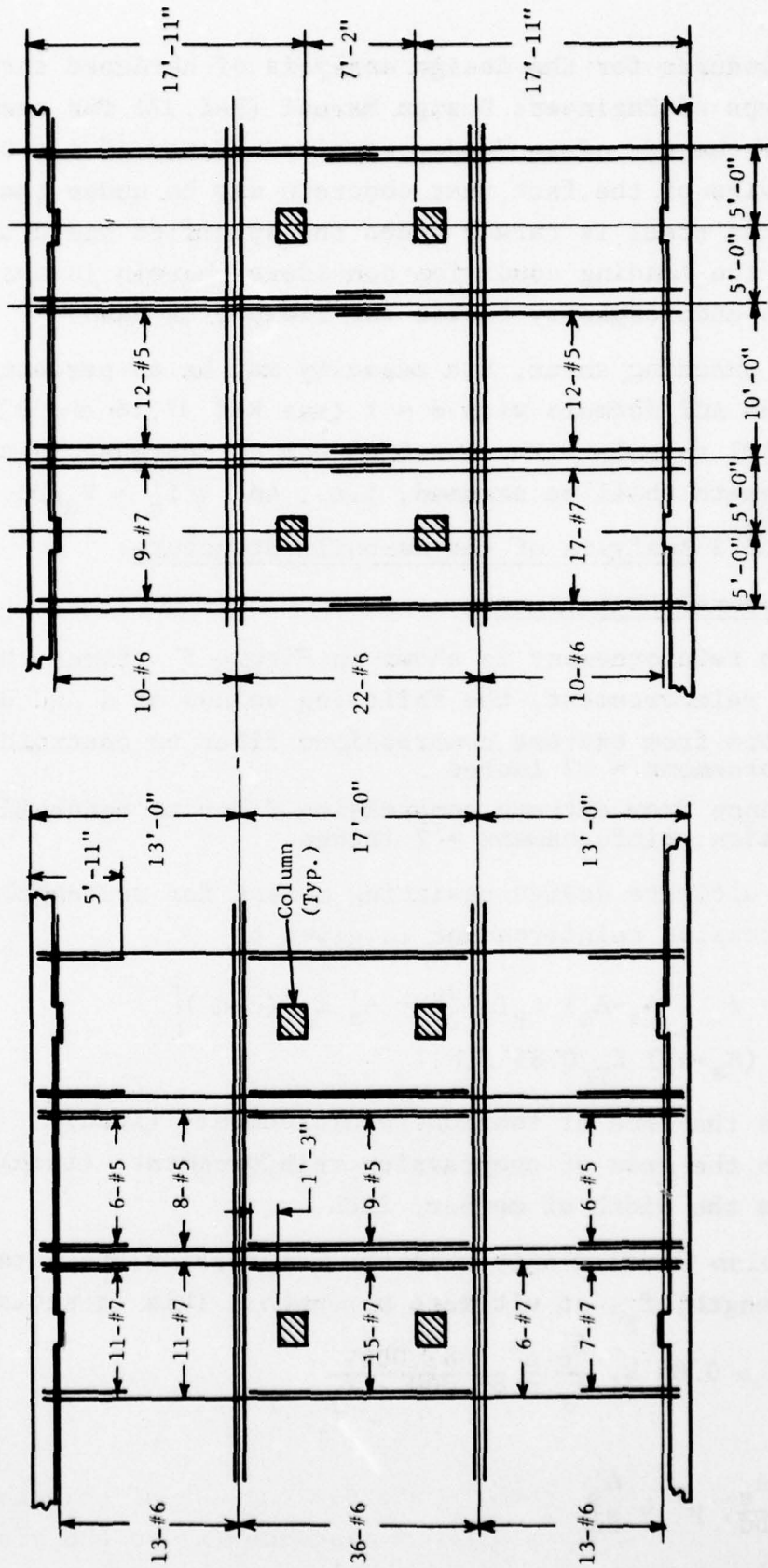

(a) top steel

(b) bottom steel

Figure 5. Slab Reinforcement Layout

$$k_1 = 0.85 \text{ for } f'_c \leq 4000 \text{ psi}$$

$$k_1 = 0.85 - (0.05) \frac{f'_c - 4000}{1000} \text{ for } f'_c > 4000 \text{ psi.}$$

When (p-p') is less than the value given by equation (2) the effect of compression steel on the capacity of the section is neglected. Using equation (2) for the case under consideration, we find that p-p' should be greater than 0.021 for compressive steel to be effective. In terms of unit steel area this means that  $A_s - A'_s$  must be greater than 3.0 sq inch/ft. Referring to Table 2, it is seen that this is not the case and therefore compression steel is neglected. Equation (1) reduces to

$$M_u = A_s f_y \left(d - \frac{a}{2}\right). \quad (3)$$

Analysis of the static capacity of the slab is considered next.

The possible slab yield patterns are shown in Figure 6, 7 and 8. It should be noted that to have yield lines along Ia and IIa (see Figure 6), the top bars extending 1'-3" (see Figure 5) from the face of the columns are neglected as they are too short to develop the negative moment capacity.

#### Yield Line Pattern 1 (see Figure 6)

Considering the free-body diagram shown in Figure 6b the moment equilibrium equations are

$$-M_a - M_b + w \ell_1 \frac{x^2}{2} = 0 \quad w_a = \frac{2}{\ell_1 x^2} (M_a + M_b) \quad (4)$$

$$M_b + M_c - \frac{w \ell_1}{2} (172.5 - x)^2 = 0 \quad w_b = \frac{2}{\ell_1} \frac{M_b + M_c}{(172.5 - x)^2} \quad (5)$$

$$\ell_1 = 20 \text{ ft}$$

$$\ell = 14 \text{ ft } 4\text{-}1/2 \text{ inches}$$

Since  $w_a$  is to be equal to  $w_b$ , then

$$(M_a + M_b)(172.5 - x)^2 = (M_b + M_c)x^2 \quad (6)$$

Therefore for strip I (see Figure 6a) the use of this equation results in the following minimum distance (x) to the yield line

$$(682 + 235 + 290 + 201)(172.5 - x)^2 = (290 + 201 + 352 + 135)x^2$$

$$1408 (172.5 - x)^2 = 978 x^2$$

$x = 95$  inches.

Substituting this value in equation (4) and subtracting the dead load ( $w_{dl}$ ), the yield load ( $w_1$ ) is

$$w_1 + \frac{2}{\ell_1 x^2} (M_a + M_b) - w_{dl} = \frac{2(1408)(10)(1000)}{20(12)(9025)} - 1.22$$

$$w_1 = 11.78 \text{ psi}$$

TABLE 2. COMPUTATION OF ULTIMATE MOMENTS

	Steel Number	Steel Size	$\frac{nA^*}{\ell}$	$A_s, A'_s$ sq inch/ft	a/2 inch	d-a/2 inch	A $f_y$ k/ft	$M_u$ kip-inches/ft
Positive Steel	9	#7	9(0.6)/10	0.54	0.324	11.68	24.8	290.0
	17	#7	17(0.6)/10	1.02	0.613	11.39	46.9	534.0
	12	#5	12(0.31)/10	0.372	0.224	11.78	17.1	201.0
	10	#6	10(0.44)/13	0.338	0.203	11.80	15.55	183.5
	22	#6	22(0.44)/17	0.57	0.342	11.66	26.2	306.0
Negative Steel	22	#7	22(0.6)/10	1.32	0.793	11.21	60.7	682.0
	11	#7	11(0.6)/10	0.66	0.396	11.60	30.4	352.0
	21	#7	21(0.6)/10	1.26	0.756	11.24	58.0	652.0
	6	#7	6(0.6)/10	0.36	0.216	11.78	16.6	195.0
	13	#7	13(0.6)/10	0.78	0.469	11.53	35.9	415.0
	14	#5	14(0.31)/10	0.434	0.260	11.74	20.0	235.0
	8	#5	8(0.31)/10	0.248	0.149	11.85	11.4	135.0
	17	#5	17(0.31)/10	0.527	0.317	11.68	24.2	282.0
	13	#6	13(0.44)/13	0.44	0.264	11.74	20.2	237.0
	36	#6	36(0.44)/17	0.932	0.56	11.44	42.9	491.0

\*  
n - number of bars  
A - cross-sectional area of bar, sq inch  
 $\ell$  - length of slab portion, ft (see Figure 5)

#5 bar, diameter = 15.88mm  
#6 bar, diameter = 19.05mm  
#7 bar, diameter = 22.22mm  
1 sq inch/ft = 2116.67mm<sup>2</sup>/m  
1 kip-inch/ft = 0.3707 kN·m/m



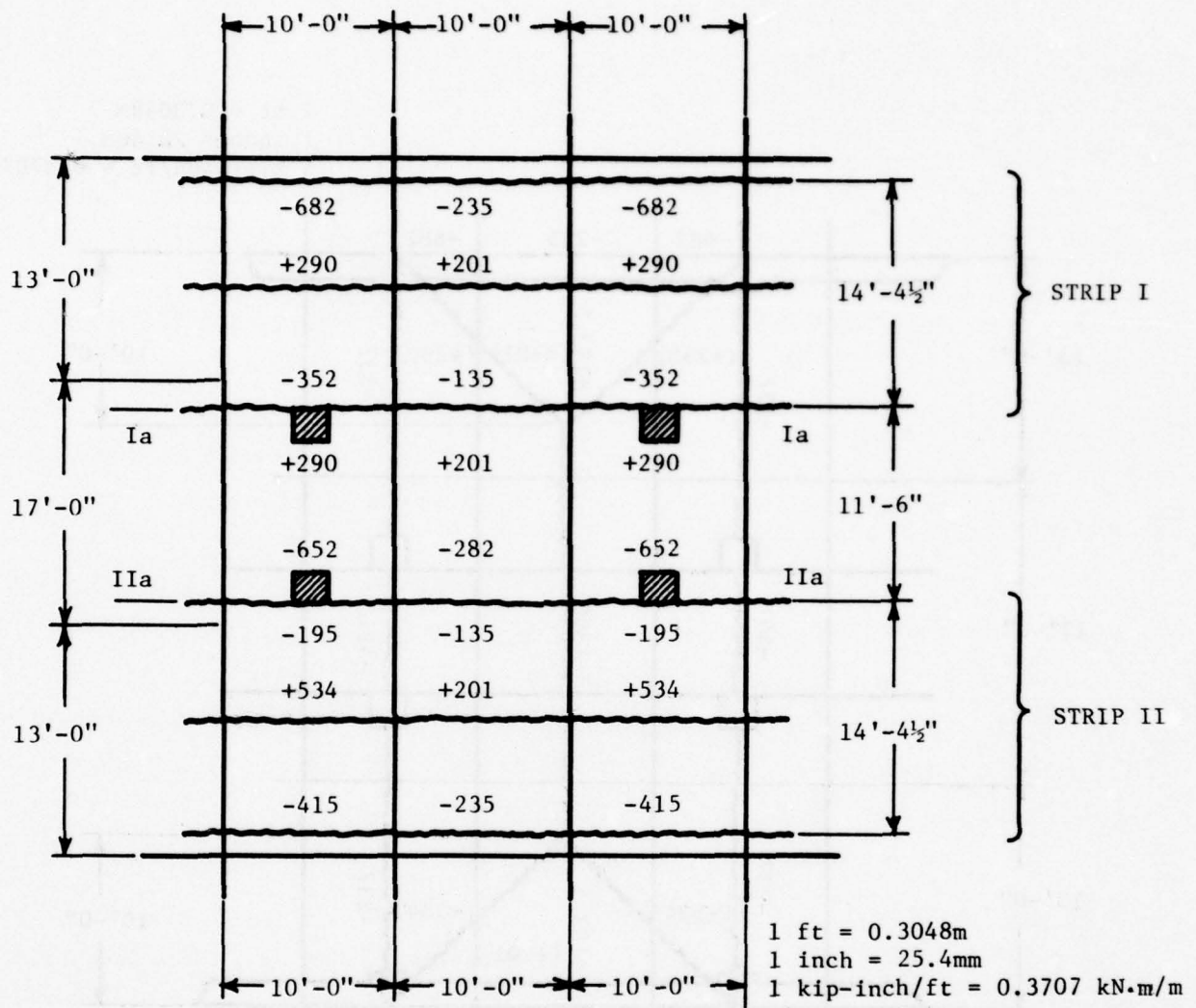

(a) Yield Line Pattern

Note: All Yield Moments are in kip-inches/ft

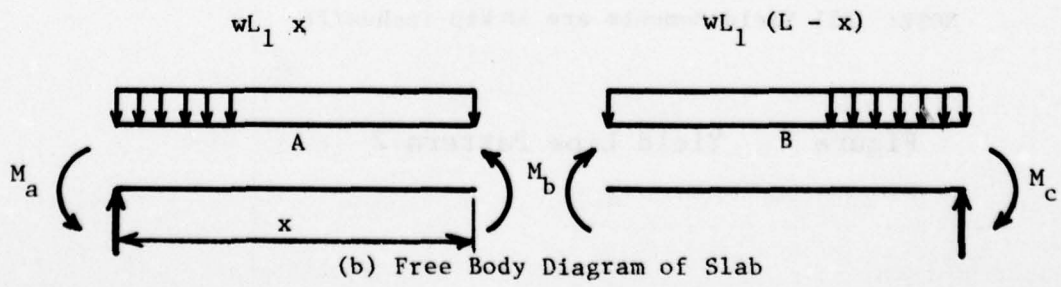
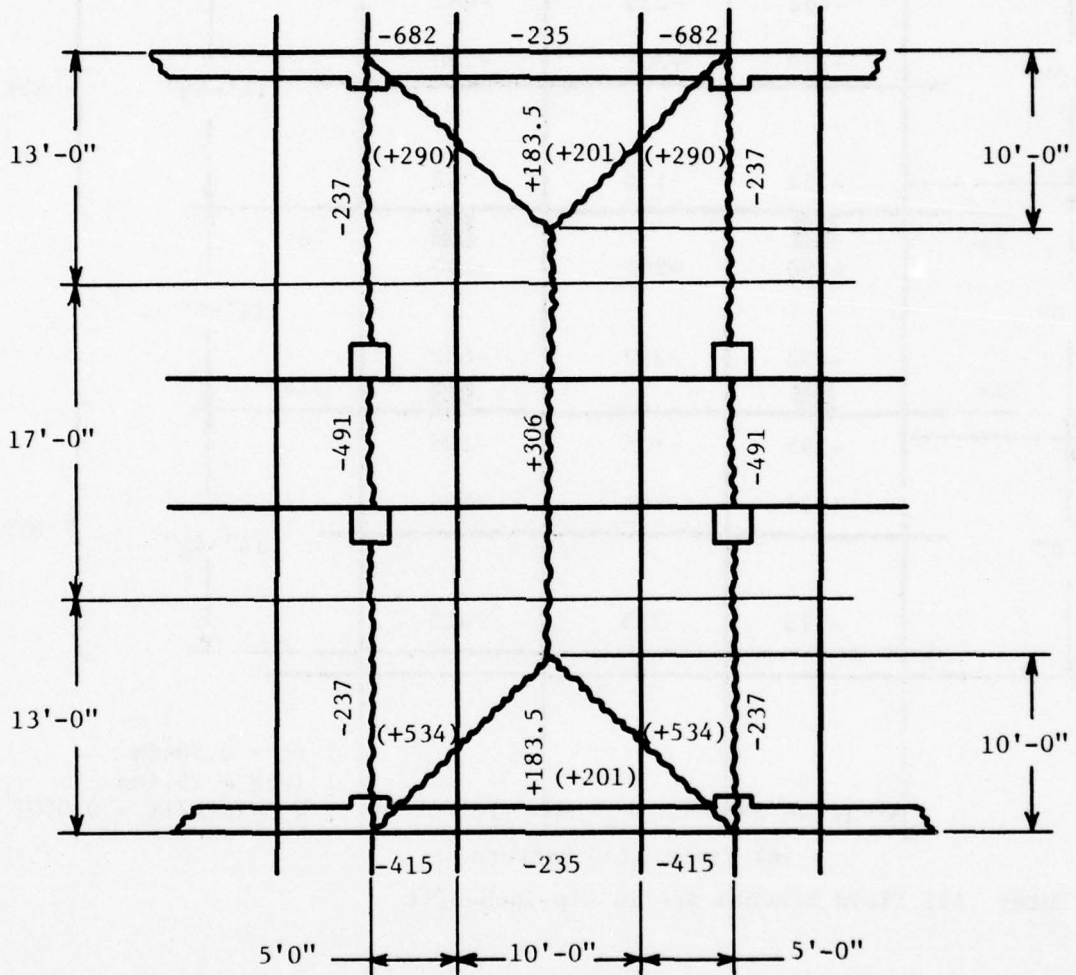

Figure 6. Yield Line Pattern 1

1 ft = 0.3048m  
 1 inch = 25.4mm  
 1 kip-inch/ft = 0.3707 kN·m/m



NOTE: All Yield Moments are in kip-inches/ft

Figure 7. Yield Line Pattern 2



1 ft = 0.3048m  
 1 inch = 25.4mm  
 1 kip-inch/ft = 0.3707 N·m/m

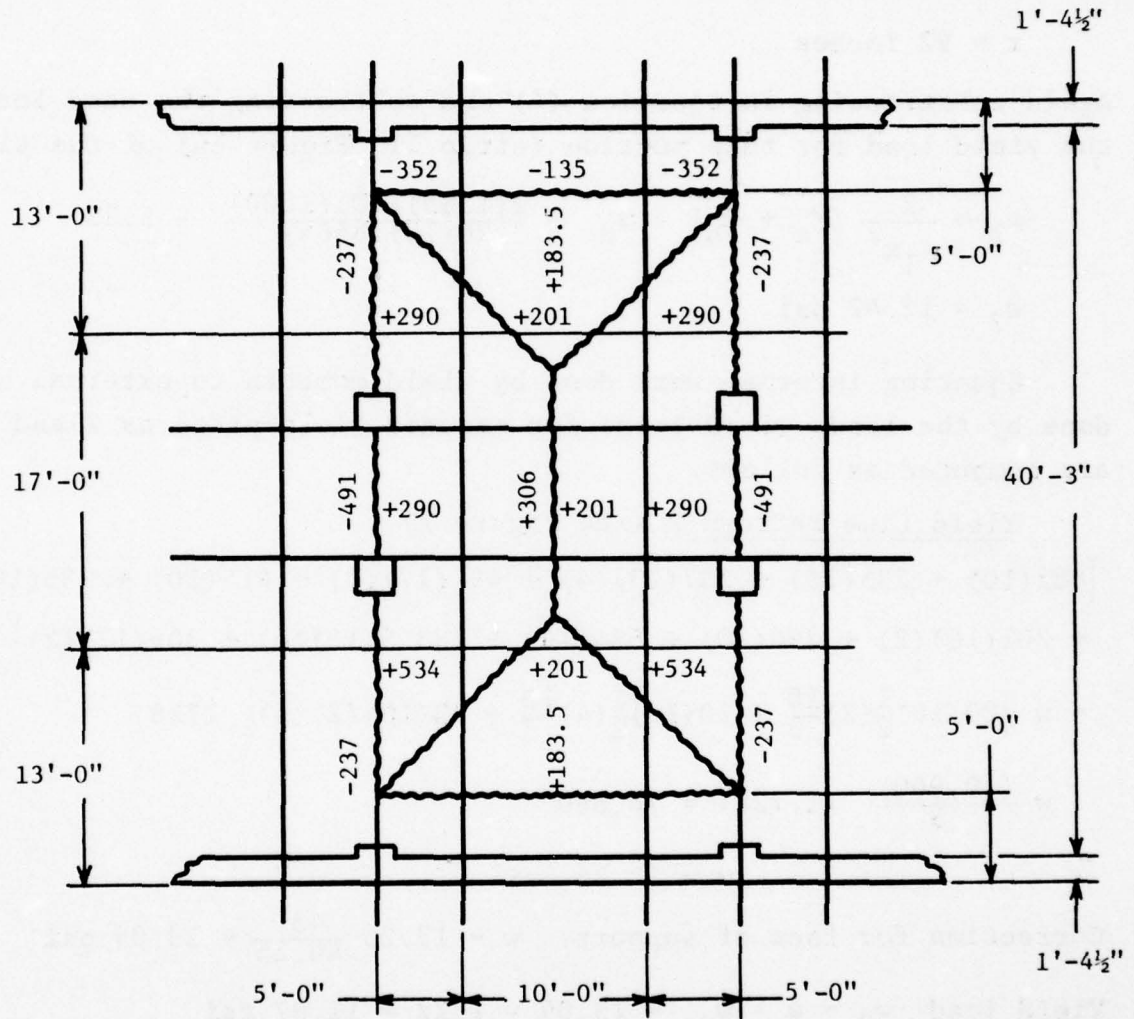

NOTE: All Yield Moments are in kip-inches/ft

Figure 8. Yield Line Pattern 3

For strip II (see Figure 6a) equation (6) results in

$$(415 + 235 + 534 + 201)(172.5 - x)^2 = (534 + 201 + 195 + 135)x^2$$

$$1385 (172.5 - x)^2 = 1065 x^2$$

$$x = 92 \text{ inches.}$$

Again substituting in equation (4) and subtracting the dead load, the yield load for this portion (strip II, Figure 6a) of the slab is

$$w_2 = \frac{2}{l_1 x^2} (M_a + M_b) - w_d = \frac{2(1385)(10)(1000)}{20(12)(8464)} - 1.22$$

$$w_2 = 12.42 \text{ psi.}$$

Equating internal work done by yield moments to external work done by the load, yield loads for assumed yield patterns 2 and 3 are computed as follows.

Yield Line Pattern 2 (see Figure 7)

$$\begin{aligned} & [682(10) + 235(10) + 237(13)(4) + 491(17)(2) + 415(10) + 235(10) \\ & + 201(10)(2) + 290(10) + 534(10) + 183.5(13)(4) + 306(17)(2)] 1000 \\ & = w \left[ 20(10)\frac{1}{2}(2)\frac{10}{3} + 10(10)\frac{1}{2}(4)\frac{10}{3} + 23(10)(2)(5) \right] 1728 \\ & w \frac{(10,900)}{3} (1.728) = 76,890 \end{aligned}$$

$$w = 12.25 \text{ psi}$$

$$\text{Correction for face of support: } w = 12.25 \frac{43}{40.25} = 13.09 \text{ psi}$$

$$\text{Yield load, } w_3 = w - w_{dl} = 13.09 - 1.22 = 11.87 \text{ psi}$$

Yield Line Pattern 3 (see Figure 8)

(Outside of the short top bars at the walls, see Figure 5).

$$\begin{aligned} & [352(10) + 135(10) + 237(8)(4) + 491(17)(2) + 195(10) + 135(10) \\ & + 201(10)(2) + 290(10) + 534(10) + 183.5(8)(4) + 306(17)(2)] 1000 \\ & = w \left[ 20(10)\frac{1}{2}(2)\frac{10}{3} + 10(10)\frac{1}{2}(4)\frac{10}{3} + 13(10)(5)(2) \right] 1728 \\ & w \frac{7900}{3} (1.728) = 60,980 \end{aligned}$$

$$w = \frac{60,980(3)}{7,900(1.728)} = 13.40 \text{ psi}$$

$$w_4 = 13.40 - 1.22 = 12.18 \text{ psi}$$

Results for these three problems are summarized

TABLE 3. SUMMARY OF STATIC YIELD LOADS  
(As-Built Structure)

Yield Line Pattern	Yield Load, psi (kPa)
1 (Figure 4)	11.78 (81.22), 12.42 (85.63)
2 (Figure 5)	12.25 (84.46)
3 (Figure 6)	12.18 (83.98)

The three yield line patterns used here are considered to be reasonable choices based on the makeup of the slab and the type of loading, i.e., uniform load. Other reasonable yield line patterns cannot be very different from these three and therefore the minimum yield load determined, i.e., 11.78 psi, is considered to be sufficiently close to the actual minimum.

#### Dynamic Flexural Resistance

For megaton range blast loadings with peak overpressures less than 10 psi, the positive phase duration ( $t_d$ ) is greater than 1.6 sec. For the slab analyzed, the fundamental period (T) is approximately 0.0311 sec. With these data,  $t_d/T > 50$  and  $t_m/T \sim 1/2$  where  $t_m$  is the time to maximum response. For loadings of long durations and such that the variation up to the time of maximum response is negligible, equation (7), (Ref. 7) is applicable

$$p = R_m (1 - 1/2\mu) \quad (7)$$

where  $p$  = peak overpressure (step pulse)

$R_m$  = ultimate resistance (bilinear resistance function)

$\mu = y_m/y_e$  = ratio of maximum to yield deflections.

For the slab analyzed, the mass and the stiffness (assuming that yield line pattern 1 governs) are



$$m \text{ (mass)} = 6.52 \text{ lb-sec}^2/\text{inch}$$

$$k \text{ (stiffness)} = 20.44(10)^4 \text{ lb/inch}$$

Taking yield line pattern 1, strip I (see Figure 6),  $R_m = 11.78$  psi, to initiate yielding,  $\mu = 1$

$$p_y = \frac{R_m}{2} = 5.89 \text{ psi (yield overpressure)}$$

To produce catastrophic collapse take  $\mu \sim 4$

$$p_u = 11.78 (1 - 1/8) = 10.31 \text{ psi (collapse overpressure)}$$

Corresponding values for strip II (Figure 4) with  $R_m = 12.42$  are

$$p_y = \frac{R_m}{2} = 6.21 \text{ psi}$$

$$p_u = \frac{7}{8} R_m = 10.87 \text{ psi}$$

#### Static Shear Capacity

The critical section for shear is assumed to be at the columns. The first step is to determine how the load is proportioned between the two rows of columns. An equivalent rigid frame (see Figure 9) approximates a section through the building and moment distribution is used to determine how the load is distributed.

Computation of relative stiffness ( $\bar{k}$ ), (see Figure 9)

$$\bar{k} = \frac{I}{\ell} \text{ (ft)}^3$$

$$\text{Interior columns: } 12I_1 = \left(\frac{26}{12}\right)^4 = 22.04, \quad 12\bar{k}_1 = 1.84$$

$$12I_2 = \left(\frac{20}{12}\right)^4 = 7.72, \quad 12\bar{k}_2 = 0.75$$

$$\text{Walls: } 12I_3 = 7.72 + 9.42 \left(\frac{8}{12}\right)^3 = 10.51, \quad 12\bar{k}_3 = 1.02$$

$$12I_4 = 22.04 + 20 \left(\frac{16.5}{12}\right)^3 = 74.39, \quad 12\bar{k}_4 = 4.96$$

Floor slabs (assume symmetry):

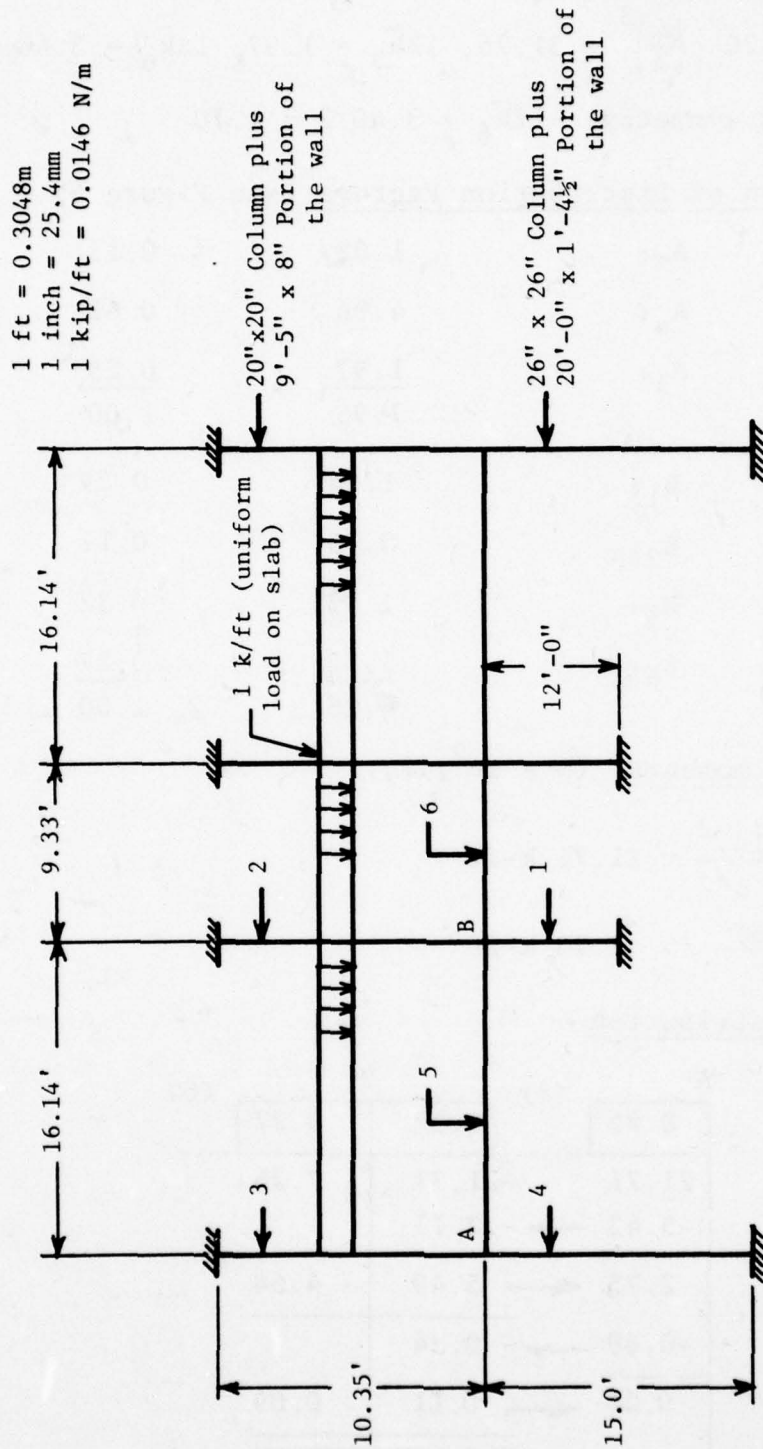

Figure 9. Assumed Equivalent Rigid Frame Representing a Section Through the Building

$$12I_5 = 20 \left( \frac{14}{12} \right)^3 = 31.76, \quad 12\bar{k}_5 = 1.97; \quad 12\bar{k}_6 = 3.40$$

Modify  $12\bar{k}_6$  for symmetry:  $12\bar{k}_6 = 3.40/2 = 1.70$

Computation of Distribution Factors (see Figure 9)

Joint A:	A <sub>3</sub> :	1.02	0.13
	A <sub>4</sub> :	4.96	0.62
	A <sub>5</sub> :	<u>1.97</u>	<u>0.25</u>
		7.95	1.00
Joint B:	B <sub>1</sub> :	1.84	0.29
	B <sub>2</sub> :	0.75	0.12
	B <sub>5</sub> :	1.97	0.32
	B <sub>6</sub> :	<u>1.70</u>	<u>0.27</u>
		6.26	1.00

Fixed-end moments ( $M = wl^2/12$ )

$$M_5 = \frac{(16.14)^2}{12} = 21.71 \text{ k-ft}$$

$$M_6 = \frac{(9.33)^2}{12} = 7.25 \text{ k-ft}$$

Moment Distribution

A	(5)	B	(6)
0.25	0.32	0.27	
21.71	-21.71	7.25	
-5.43	→ - 2.71		
2.75	← 5.49	4.64	
-0.69	→ - 0.34		
0.06	← 0.11	0.09	
-0.01			
18.39	-19.16	11.98	



Shear at Column (Joint B, Figure 7)

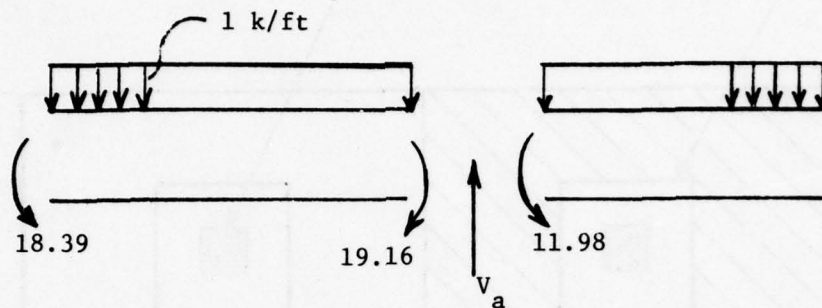

$$V_a = \frac{19.16 - 18.39}{16.14} + \frac{16.14 + 9.33}{2} = 0.05 + 12.74 = 12.79 \text{ kips}$$

Assuming no continuity of the frame,  $V_a = \frac{16.14 + 9.33}{2} = 12.74 \text{ kips}$

Slab area (A) contributing to an interior column reaction is then

$$A = 20(12.79) \text{ sq ft}$$

Ultimate Static Shear at Column (see Figure 10)

$$v_u = 4\phi\sqrt{f'_c} \quad \text{Ultimate shear stress (ACI 318-71, Section 11.10)}$$

$$v_u = 4(0.85)\sqrt{3000} = 186.23 \text{ psi}$$

$$V_u = v_u b_o d = (186.23)(38)(4)(12) = 339,683.52 \text{ lb}$$

where  $V_u$  = column shear

$b_o$  = perimeter around the column at a distance of  $d/2$  from the face of the column =  $4(38)$  sq inch

$$A_v = 20(12.80) - \left(\frac{38}{12}\right)^2 = 256 - 10.03 = 245.97 \text{ sq ft}$$

$$w_u = \frac{V_u}{A_v} - w_{dl} = \frac{339,683.52}{(245.97)(144)} - 1.22 = 9.59 - 1.22 = 8.37 \text{ psi}$$

where  $w_u$  is the static uniform load necessary to produce ultimate shear stress ( $v_u = 186.23$  psi) at the perimeter.

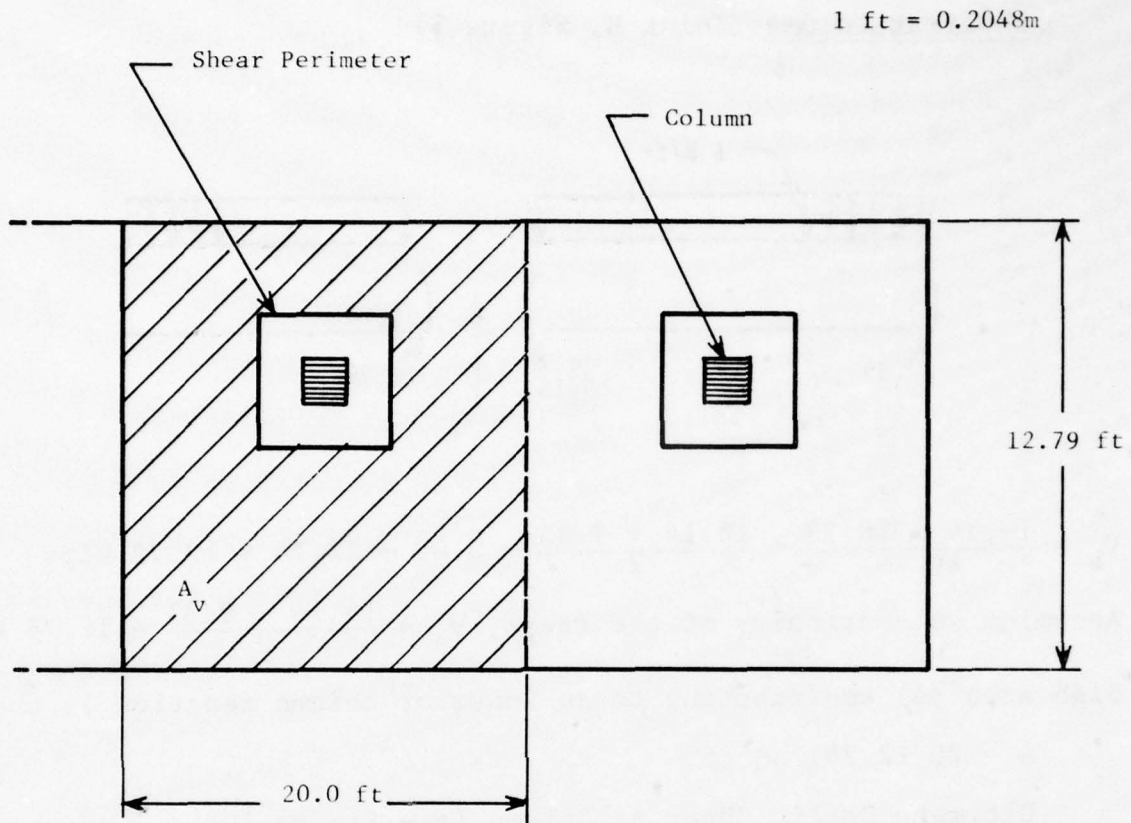

Figure 10. Definition of Column Loading Terms

### Dynamic Shear Resistance

From Ref. 20 the dynamic reactions (shears) for the elastic and plastic ranges of slab responses are:

$$V_e = 0.36R + 0.14p \quad \text{Total dynamic shear elastic range}$$

$$V_p = 0.38R_m + 0.12p \quad \text{Total dynamic shear, plastic range} \quad (8)$$

If response is allowed in the elastic range, then  $p = \frac{R}{2}$ , where  $R$  is the elastic flexural resistance of the slab.

$$V_e = (0.36 \times 2 + 0.14) p_y A = 0.86 p_y A$$

$$V_e = w_u \frac{A}{2}$$

$$\therefore p_y = \frac{w_u}{2(0.86)} = \frac{8.37}{1.72} = 4.87 \text{ psi (yield overpressure)}$$

If response is allowed in the plastic range then for  $\mu = 4$

$$p_u = \frac{7}{8} R_m$$

$$V_u = (0.38 \times \frac{8}{7} + 0.12) p_u A = 0.55 p_u A$$

$$V_u = w_u \frac{A}{2}$$

$$\therefore p_u = \frac{w_u}{2(0.55)} = \frac{8.37}{1.10} = 7.61 \text{ psi (collapse overpressure)}$$

Dynamic flexural and shear capacities of the slab are summarized

TABLE 4. SUMMARY OF RESULTS

	Shear Capacity psi(kPa)	Flexural Capacity psi(kPa)	
		Strip I*	Strip II
To produce yielding	4.87(33.58)	5.89(40.61)	6.21(42.82)
To collapse	7.61(52.47)	10.31(71.08)	10.87(74.95)

\* Strips I and II are shown in Figure 6a.

### Analysis of Upgraded Structure

The upgrading concept consists of increasing the size of slab area resisting shear in the vicinity of the column. The concept, which is a variation of that described in Ref. 14, is shown in Figure 3.

### Flexural Resistance

The upgrading concept modifies only the first yield line pattern (Figure 6) in which case the yield lines at the columns displace approximately 1.0 ft away from the columns. Yield line patterns 2 and 3 (Figure 7 and 8) as well as the corresponding yield loads remain the same. Results for the three problems are summarized:



TABLE 5. SUMMARY OF STATIC YIELD LOADS  
(Upgraded Structure)

<u>Yield Line Pattern</u>	<u>Yield Load, psi (kPa)</u>
1 (Figure 4)	14.09 (97.15), 14.56 (100.39)
2 (Figure 5)	12.25 (84.46)
3 (Figure 6)	12.18 (83.98)

The minimum static yield load for the upgraded slab is 12.18 psi. The corresponding value for the as-built slab is 11.78 psi. Proceeding as before, the corresponding dynamic loads necessary to initiate yielding ( $p_y$ ) and to produce catastrophic collapse ( $p_u$ ) are

$$p_y = \frac{12.18}{2} = 6.09 \text{ psi}$$

$$p_u = \frac{7}{8} (12.18) = 10.66 \text{ psi.}$$

#### Shear Resistance

Referring to Figure 10 and proceeding as in the previous case we obtain

$$V_u = (186.24)(62)(4)(12) = 554,220.48 \text{ lb} = \text{column shear}$$

$$A_v = (20)(12.8) - \left(\frac{62}{12}\right)^2 = 256 - 26.69 = 229.31 \text{ sq ft}$$

$$w_u = \frac{V_u}{A_v} - w_{dl} = \frac{554,220.48}{229.31(144)} - 1.22 = 16.78 - 1.22 = 15.56 \text{ psi}$$

where  $w_u$  is the static uniform load necessary to produce ultimate shear stress ( $v_u = 186.23$  psi) at the perimeter. The corresponding dynamic shear capacity is computed as

$$p_y = \frac{15.56}{1.72} = 9.05 \text{ psi} \quad (\text{yield overpressure})$$

$$p_u = \frac{15.56}{1.10} = 14.15 \text{ psi} \quad (\text{collapse overpressure})$$

Dynamic flexural and shear capacities of the slab are summarized

TABLE 6. SUMMARY OF RESULTS  
(Upgraded Structure)

	Shear Capacity psi(kPa)	Flexural Capacity psi(kPa)
To produce yielding	9.05 (62.40)	6.09 (41.99)
To collapse	14.15 (97.56)	10.66 (73.50)

2.1.4 Discussion - This particular shelter was chosen for analysis not because a flat plate floor system has any particular blast resistance advantages over other floor systems, in fact it has none, but because this system has entered the building inventory in substantial numbers and should be dealt with in some manner as far as shelter is concerned.

The major reason for the popularity of this structural system is economy of construction. Formwork is simple as is the task of installing utility systems. As far as load resistance is concerned this system is susceptible to shear punching at the columns. However, if this problem can be eliminated then this system is desirable for sheltering purposes. In the analysis performed the upgrading concept (see Figure 3) was able to shift the failure mode from shear to flexure resulting in increased load-carrying capacity. The important thing to consider is that shear failure is more sudden than flexural failure and therefore should be avoided. This upgrading concept was able to eliminate it. Although the increase in protective capabilities was only 34 percent, this is expected to be higher for buildings designed for heavier conventional loads.

## 2.2 Basement Shelter in an Apartment Building

2.2.1 Building Description - The building considered (see Figure 11) is a 10-story apartment building with a basement. Its normal occupancy is about 300 persons. It is a steel framed building with masonry infilled walls and two-way reinforced concrete floor and roof system. Walls between individual apartments are of concrete masonry. Within individual apartments the rooms are separated by sheetrock-stud walls. In plan the building is laid out on a square grid with individual bays 20 ft (6.096m) wide. Plan dimensions are 120 ft by 100 ft (36.576m by 30.480m).

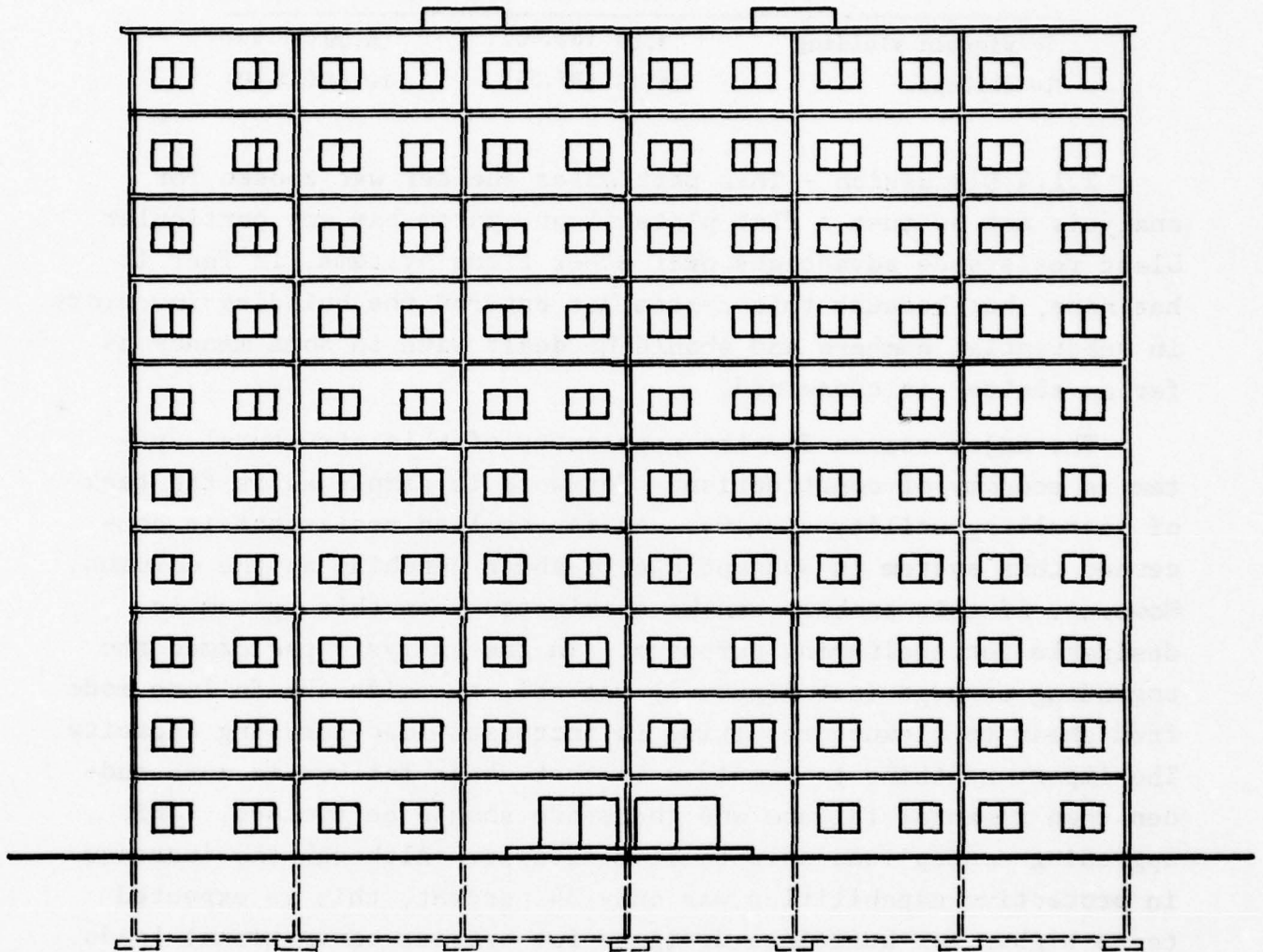

1 ft = 0.3048m

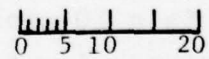

Scale: ft

Figure 11. Front Elevation



As illustrated in Figure 11, the basement overhead slab is at grade with no window apertures into the basement. The basement plan is shown in Figure 12. Approximately one-third of the basement area is taken up by mechanical equipment (heating, airconditioning, etc) and laundry and storage facilities. The rest of the area is essentially free of obstructions and can be used for sheltering purposes. The area available for shelter is approximately 8000 sq ft (743.22 m<sup>2</sup>). There are six major openings into the basement, i.e., four elevators and two stairwells.

This building is approximately 6 years old and was designed using appropriate sections of the following specifications:

- City of Chicago Building Code and Contractors Register, 1971
- Manual of Steel Construction, American Institute of Steel Construction, Inc., Seventh Edition
- ACI Standard 318-63, Building Requirements for Reinforced Concrete, ACI 318-63, June 1963

Since the basement is the only building area of interest to this study, only the design of the basement overhead floor system and associated structural components is described.

2.2.1.1 Floor Slab Design: Typical panels for the basement overhead floor system are as indicated in Figures 13 and 14 and include an interior panel, a side panel and a corner panel. The slabs were designed using Method 2 as described in the ACI Building Code. Properties of materials used are:

- $f'_c$  (ultimate compressive strength of concrete) = 4000 psi(27.58 MPa)
- $f_s$  (allowable stress in reinforcing steel) = 20,000 psi(137.90 MPa)
- $f_y$  (yield strength of reinforcing steel) = 60,000 psi(413.69 MPa)

Slab design load was as follows: dead load, including the slab, floor finish and partitions was 94 psf (4.500 kPa), live load was 40 psf (1.915 kPa) in all building areas. Slab designs are summarized in Table 7. Data given apply to both principal slab directions.

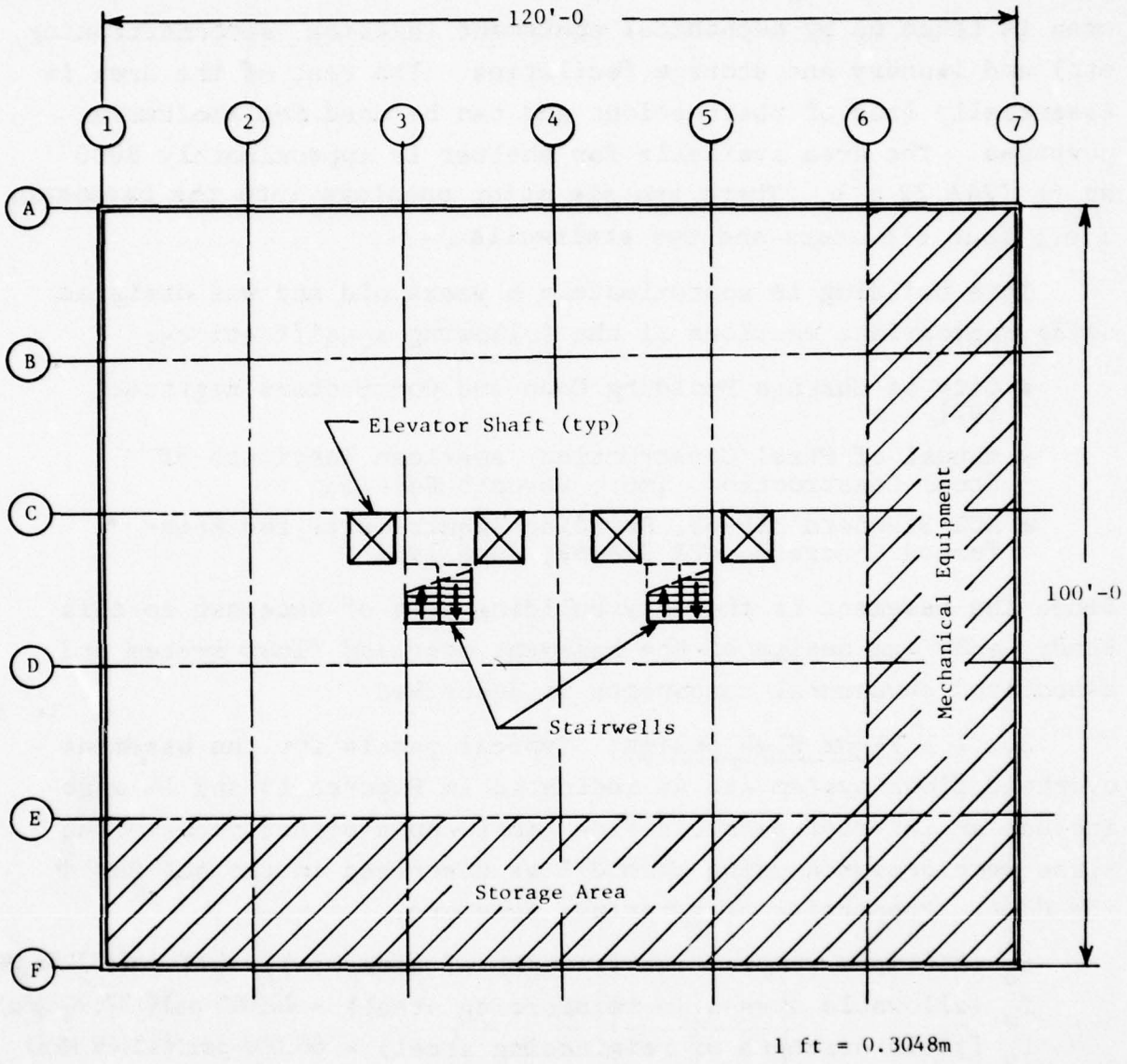

Figure 12. Basement Plan

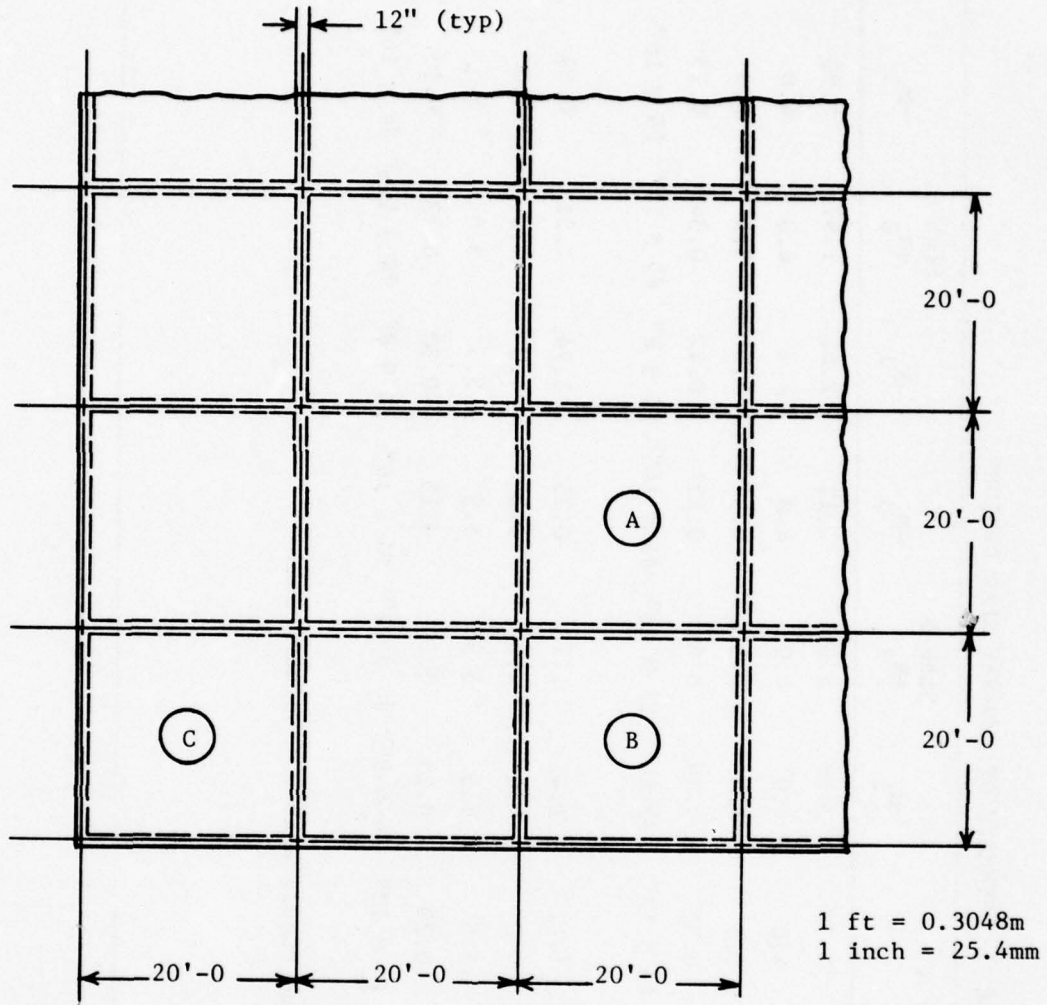

Figure 13. Typical Slab Plan

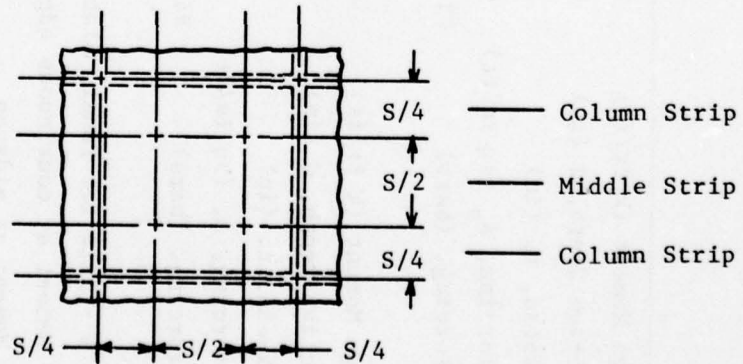

Figure 14. Typical Panel



TABLE 7. SUMMARY OF TWO-WAY SLAB DESIGNS

	Slab A		Slab B		Slab C	
	+M	-M	+M <sub>2</sub>	-M <sub>1</sub>	+M <sub>2</sub>	-M <sub>3</sub>
Design Moment (k ft/ft)	1.33	1.75	1.65	2.18	1.97	1.33
Effective Depth, d (in)	4.0	4.0	4.0	4.0	4.0	4.0
Thickness, t, (in)	5.5	5.5	5.5	5.5	5.5	5.5
Reinforcing, A <sub>s</sub> (sq in/ft)	0.23	0.31	0.29	0.39	0.34	0.23
Reinforcing, (bars)	#5 @ 16"	#5 @ 12"	#5 @ 13"	#5 @ 9½"	#5 @ 11"	#5 @ 16"
Design Moment (k ft/ft)	0.87	1.17	1.10	1.45	1.31	0.89
Effective Depth, d (in)	4.0	4.0	4.0	4.0	4.0	4.0
Thickness, t, (in)	5.5	5.5	5.5	5.5	5.5	5.5
Reinforcing, A, (sq in/ft)	0.15	0.20	0.20	0.25	0.23	0.15
Reinforcing, (bars)	#4 @ 16"	#4 @ 12"	#4 @ 12"	#4 @ 9½"	#4 @ 10½"	#4 @ 16"

Slab A - Interior Panel, Slab B - Edge Panel, Slab C - Corner Panel

M<sub>1</sub> - Moment at continuous edge

M<sub>2</sub> - Moment at midspan

M<sub>3</sub> - Moment at discontinuous edge

- #5 bar, diameter = 15.88mm
- #4 bar, diameter = 12.70mm
- 1 inch = 25.4mm
- 1 sq inch/ft = 2116.67mm<sup>2</sup>/m
- 1 k ft/ft = 4.45 kN·m/m

2.2.1.2 Beam Design: Steel beams supporting the floor slabs were assumed to be simply supported and were designed using standard procedures and criteria stipulated in the AISC Code. The beam chosen was W16x31. It was used both on the interior and along the building periphery.

2.2.1.3 Column Design: Building columns were also designed in accordance with the AISC(3-15) criteria. This resulted in a column consisting of W14x119 section. Unsupported length was taken as 10 ft. Columns were designed under the assumption of simple supports.

2.2.1.4 Beam to Column Connection Design: Beam to column connections were taken to be the shear type, i.e., no moment resistance was assumed. For the type of building and load magnitude this was considered to be an economic design. They were designed on the basis of standard AISC (4-20) provisions which resulted in the following hardware:

Three rows of 3/4 inch diameter A307 bolts with two 5-inch x 3-1/2 inch x 1/4 inch angles, 8-1/2 inches long.

This connection applies to the column flange and to the column web.

2.2.2 Evaluation of the As-Built System - This is a framed building with weak walls. It is not expected to offer any significant protection to upper story occupants beyond about 1.0 psi(6.895 kPa). Basement is the only potentially viable shelter. The basement is analyzed to determine its inherent sheltering capabilities. The analysis procedure used and corresponding results are presented.

2.2.2.1 Structural Analysis: The two-way floor system over the basement was analyzed with the object of determining failure modes and corresponding failure overpressures when subjected to the blast effects of a single, megaton-range nuclear weapon in its Mach region. These results were subsequently used to estimate the extent of protection afforded.

Theory and experimental data (Ref. 21) indicate that floor systems of the type considered here will fail first either in flexure of the slab or the supporting beams or shear failure of the connections.

Shear failure of the slabs is not expected to be a significant failure mechanism.

For the purpose of estimating the number of survivors, two levels of structural failure are considered for reinforced concrete slabs and steel beams, i.e., incipient (first yielding) failure and ultimate failure (collapse). Loads producing incipient failure are defined herein as the minimum values of flexural or shear resistance of the structural member. Thus in the case of a simply supported steel beam, incipient flexural failure is defined as the dynamic load required to produce a plastic hinge at midspan. As indicated in Figure 15 this occurs when  $\mu$  (ductility ratio  $y_m/y_y$ ) is equal to 1. Ultimate collapse is assumed to occur when  $\mu = 8$  (Ref. 22).

For two-way reinforced concrete slabs, incipient flexural failure is defined as the dynamic, uniformly applied load required to produce plastic moments for a minimum load yield pattern. When expressed in terms of a resistance function, this occurs when deflection  $y_f$  (see Figure 16) is reached. Ultimate collapse depends on whether the reinforcement is capable of developing membrane resistance. When not, flexural failure is indicated by a limiting ductility ratio, resulting in a collapse deflection of

$$y_m = \frac{0.10}{p} y_e \leq 30 y_e \quad (9)$$

where  $y_e$  is the equivalent yield deflection of the slab based on a bilinear resistance function and  $p$  is the tensile steel ratio. When the slab is capable of developing membrane resistance, then failure is indicated by a limiting deflection of

$$y_{ft} = 0.15 L_s \quad (10)$$

where  $L_s$  is the length of the slab in the long direction (Ref. 23).

Beam connections were analyzed to determine their ultimate capacity by analyzing each possible failure mechanism. Failure is assumed to occur and collapse is assumed to follow when either one or several of the following conditions is produced.



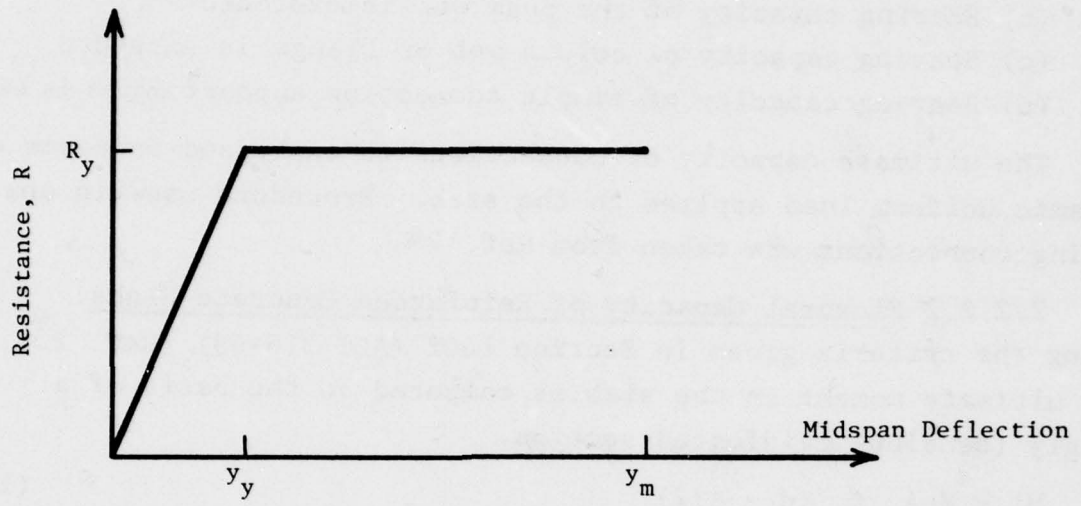

Figure 15. Resistance Function for a Simply Supported Beam

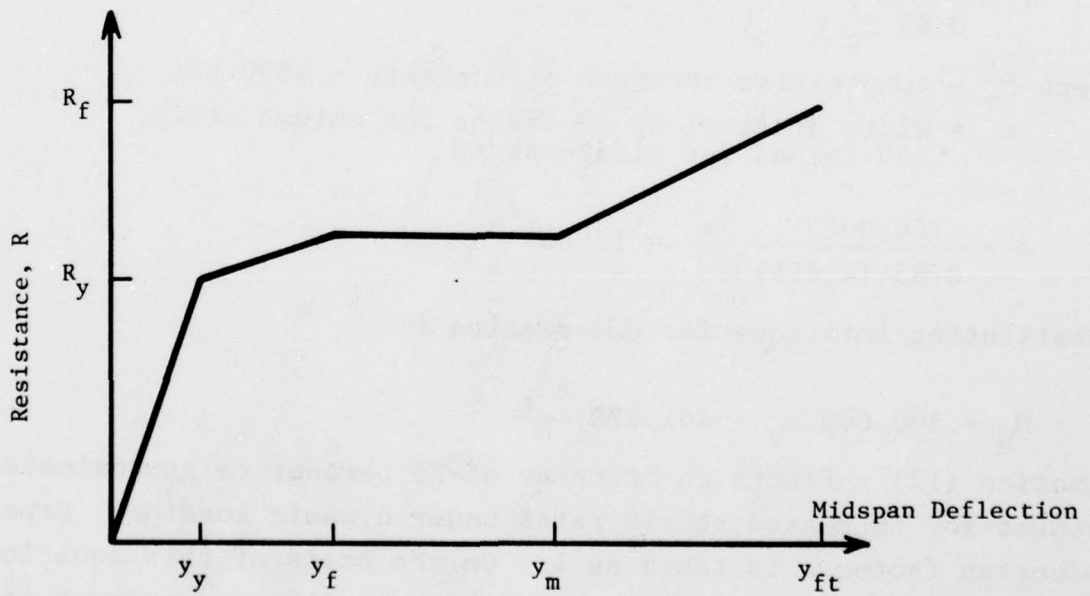

Figure 16. Resistance Function for a Reinforced Concrete Two-Way Slab

- (a) Combined shear capacity of the bolts is exceeded
- (b) Bearing capacity of the beam web is exceeded
- (c) Bearing capacity of column web or flange is exceeded
- (d) Bearing capacity of simple connection support angles is exceeded

The ultimate capacity of connections is expressed in terms of dynamic uniform load applied to the slab. Procedure used in analyzing connections was taken from Ref. 24.

#### 2.2.2.2 Flexural Capacity of Reinforced Concrete Slabs:

Using the criteria given in Section 1602 (ACI 318-63) (Ref. 25), the ultimate moment in the slab is computed on the basis of a singly (tension) reinforced section.

$$M_u = \phi A_s f_y (d - a/2) \quad (11)$$

where  $\phi$  = capacity reduction factor = 0.9

$A_s$  = area of tension reinforcement

$f_y$  = yield strength of reinforcement = 60,000 psi

$d$  = distance from extreme compression fiber to centroid of tension reinforcement = 4 inches

$$a = \frac{A_s f_y}{0.85 f'_c b}$$

where  $f'_c$  = compressive strength of concrete = 4000 psi

$b$  = width of section, 60 inches for column strip,  
120 inches for middle strip

$$a = \frac{60,000}{0.85 (4,000)} \frac{A_s}{b} = 17.65 \frac{A_s}{b}$$

Substituting into equation (11) results in

$$M_u = 300,000 A_s - 661,875 \frac{A_s^2}{b} \quad (12)$$

Equation (12) reflects an increase of 25 percent to approximately account for increased strain rates under dynamic loading. Capacity reduction factor  $\phi$  is taken as 1. On the basis of this equation and the quantity of reinforcement used, the ultimate moments in the respective portions of the slabs are computed and tabulated as follows.

Interior Panel

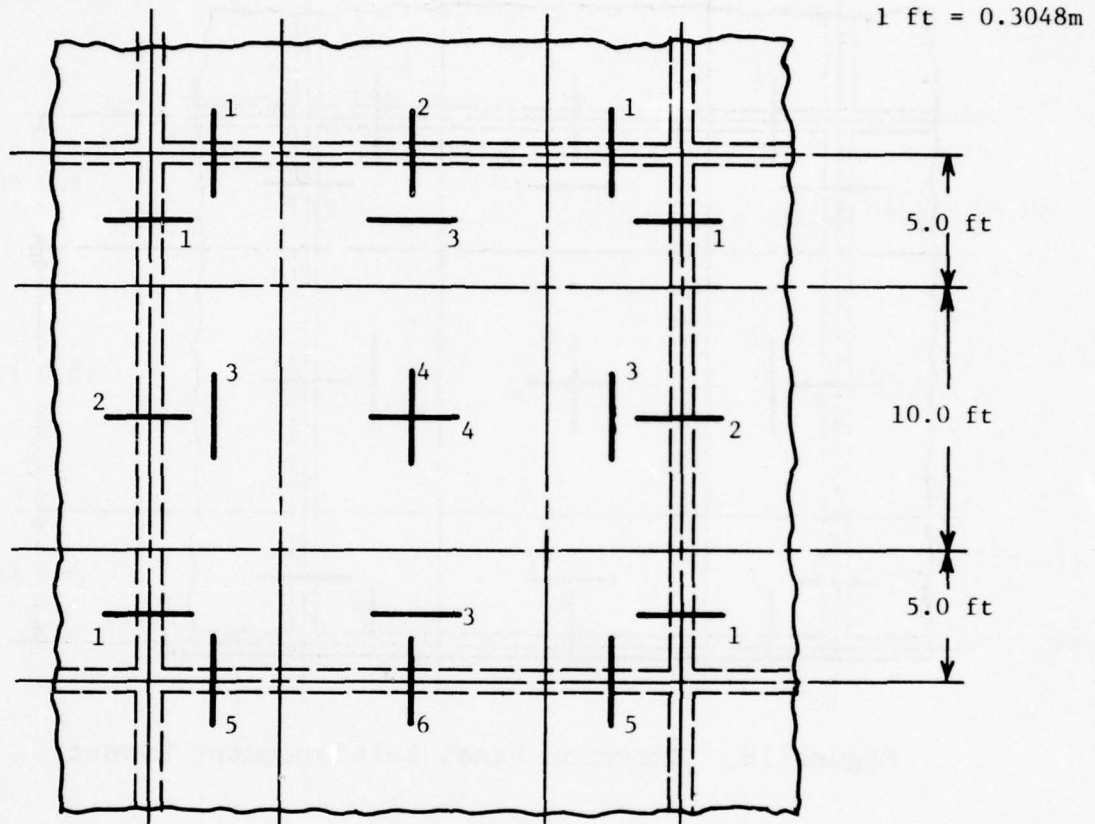

Figure 17. Interior Panel Reinforcement Layout

TABLE 8. INTERIOR PANEL DATA

Location	(+)/(-)	Bars	$A_s$ inch <sup>2</sup>	b inch	$M_u$ lb-inch	$\bar{m}$ lb-inch/ft
1	-	6 - #4	1.20	60	344,115	68,823
2	-	12 - #5	3.68	120	1,029,305	102,931
3	+	6 - #4	1.20	60	344,115	68,823
4	+	9 - #5	2.79	120	794,066	79,407
5	-	7 - #4	1.40	60	398,379	79,676
6	-	13 - #5	4.03	120	1,119,421	111,942

See Table 7 for SI conversion units.



## Exterior Panel

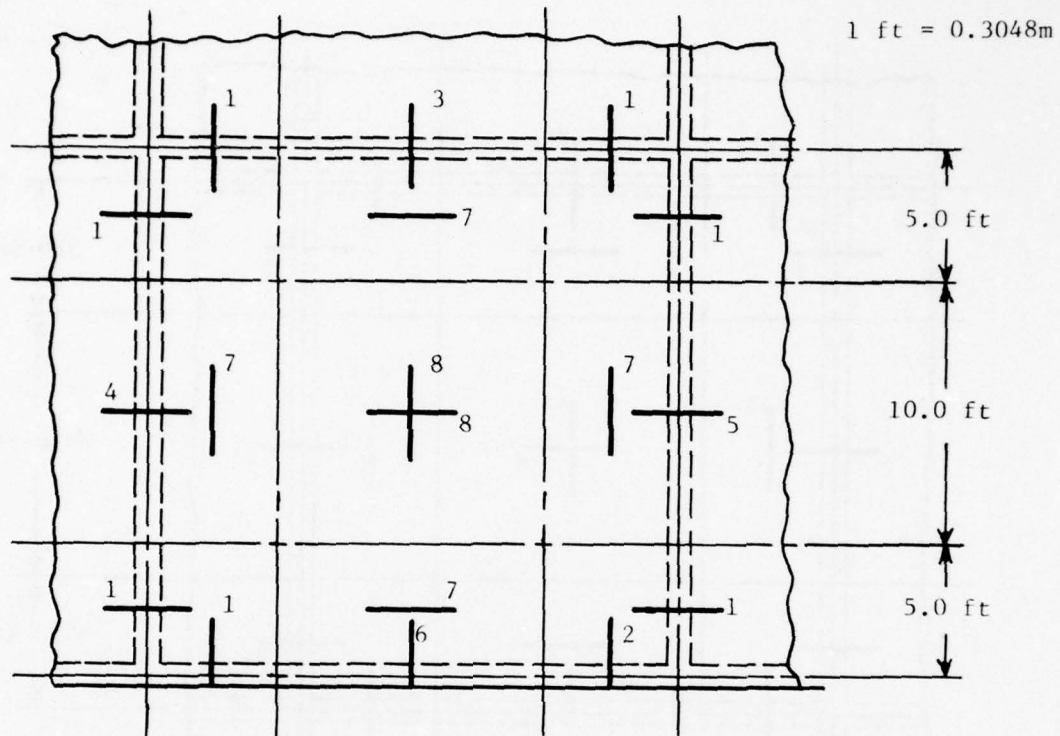

Figure 18. Exterior Panel Reinforcement Layout

TABLE 9. EXTERIOR PANEL DATA

Location	(+)/(-)	Bars	$A_s$ inch <sup>2</sup>	b inch	$M_u$ lb-inch	$\bar{m}$ lb-inch/ft
1	-	7 - #4	1.4	60	398,379	79,676
2	-	5 - #4	1.0	60	288,969	57,794
3	-	13 - #5	4.03	120	1,119,421	111,942
4	-	15 - #5	4.65	120	1,275,738	127,574
5	-	14 - #5	4.34	120	1,198,110	119,811
6	-	8 - #5	2.48	120	710,077	71,008
7	+	6 - #4	1.20	60	344,115	68,823
8	+	10 - #5	3.10	120	876,995	87,699

See Table 7 for SI conversion units.

## Corner Panel

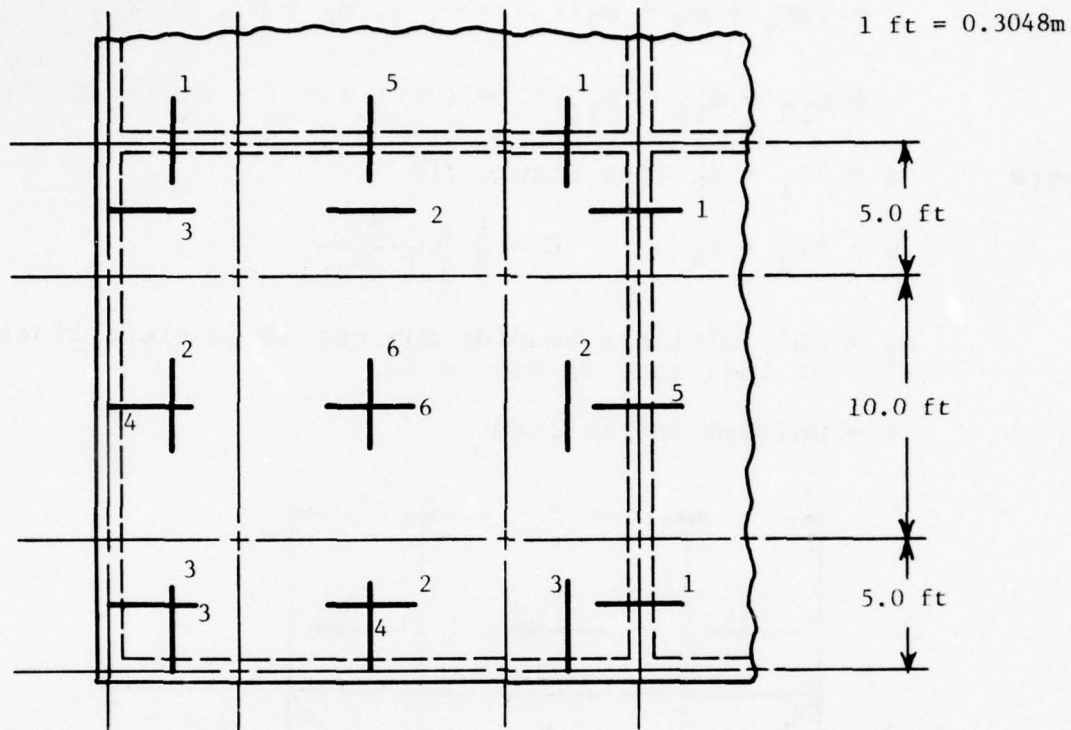

Figure 19. Corner Panel Reinforcement Layout

TABLE 10. CORNER PANEL DATA

Location	(+)/(-)	Bars	$A_s$ inch	b inch	$M_u$ lb-inch	$\bar{m}$ lb-inch/ft
1	-	8 - #4	1.6	60	451,760	90,352
2	+	6 - #4	1.2	60	344,115	68,823
3	-	5 - #4	1.0	60	288,969	57,794
4	-	9 - #5	2.79	120	794,066	79,407
5	-	15 - #5	4.65	120	1,275,738	127,574
6	+	11 - #5	3.41	120	958,864	95,886

See Table 7 for SI conversion units.

The static, uniform load capacity of these slabs is computed using equation (13) which is applicable to the slab having the yield pattern and ultimate moments as shown in Figure 20.

$$wab = \frac{b}{a} [(m_1 + 2m_2 + m_3 + 2m_6 + m_9 + m_{23})\ell_1 + (2m_4 + m_5 + m_7)\ell_2] + \frac{12}{a} [(2m_8 + m_{11} + 2m_{12} + m_{13} + m_{19} + m_{21})\ell_3 + (2m_{10} + m_{15} + m_{17})\ell_4]C \quad (13)$$

where  $a = 2\ell_1 + \ell_2$  (see Figure 20)

$$b = 2\ell_3 + \ell_4 \quad C = \frac{1}{2} \frac{a - a/b}{3 - 2a/b}$$

$m_i$  = unit ultimate bending moments along yield lines as indicated in Figure 20.

$w$  = uniform static load

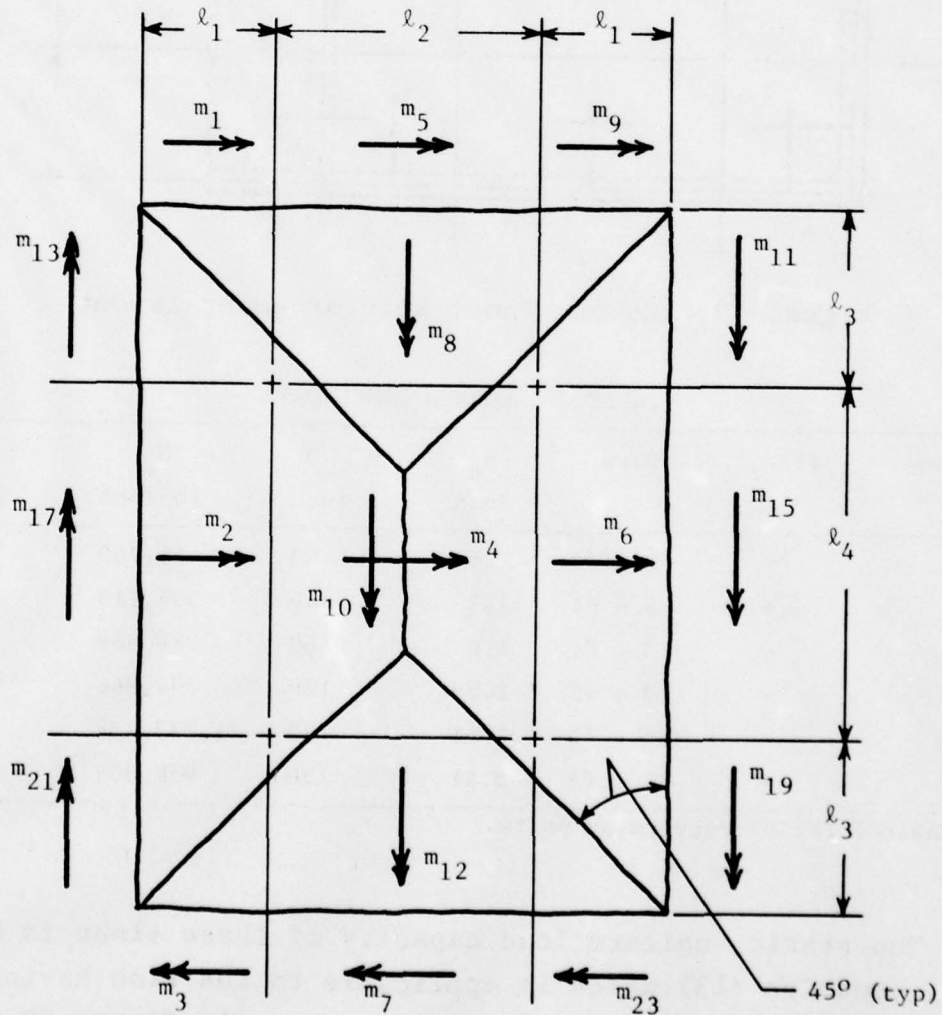

Figure 20. Slab Yield Pattern



Applying this equation to the interior panel, the corresponding ultimate static uniform load is determined. Referring to Table 8, Figure 17 and Figure 20, the following is obtained.

$$\bar{m}_1 = m_1 = m_9 = m_{11} = m_{13} = m_{19} = m_{21}$$

$$\bar{m}_2 = m_5 = m_{15} = m_{17}$$

$$\bar{m}_3 = m_2 = m_6 = m_8 = m_{12}$$

$$\bar{m}_4 = m_4 = m_{10}$$

$$\bar{m}_5 = m_3 = m_{23}$$

$$\bar{m}_6 = m_7$$

$$\bar{m}_1 = \bar{m}_3$$

$$\bar{m}_4 = \bar{m}_5$$

$$C = 1/2$$

$$l_2 = 2l_1$$

$$l_3 = l_1$$

$$l_4 = l_2$$

$$l_1 = a/48$$

Substituting into equation (13) results in

$$w = \frac{1}{4a^2} (7\bar{m}_1 + 3\bar{m}_2 + 5\bar{m}_4 + \bar{m}_6) = 5.64 \text{ psi}$$

The corresponding dynamic capacity is estimated on the basis of equation (7). Ductility ratios for yielding and collapse are taken as 1.0 and 17 (Ref. 22) respectively. The slab dead load is computed as 0.65 psi. On this basis, the uniformly applied dynamic loads of long duration required to produce yielding and collapse are given as

$$p_y = (5.64 - 0.65)(0.5) = 2.50 \text{ psi}$$

$$p_u = (5.64 - 0.65)\frac{33}{44} = 4.84 \text{ psi}$$

Dynamic flexural capacity results are summarized in Table 10.

TABLE 11. DYNAMIC FLEXURAL CAPACITY

	$P_y$ , psi(kPa)	$P_u$ , psi(kPa)
Interior Panel	2.50 (17.24)	4.84 (33.37)
Exterior Panel	2.62 (18.06)	5.06 (34.89)
Corner Panel	2.65 (18.27)	5.10 (35.16)

2.2.2.3 Shear Capacity of Reinforced Concrete Slabs: The total dynamic reaction for a square, two-way slab fixed on four sides is given (Ref. 20) as

$$V = 0.10P + 0.15R \quad (\text{Elastic Range}) \quad (14)$$

$$V = 0.09P + 0.16R_m \quad (\text{Plastic Range}) \quad (15)$$

where  $P$  is the total dynamic load acting on the slab

$R$  is the resistance corresponding to the applied load

$R_m$  is the ultimate resistance. Note that an equivalent bilinear resistance function is assumed.

Since there is no web reinforcement, then the nominal ultimate shear stress is taken (ACI 318-63, Section 1701) as

$$v_c = 2 \phi \sqrt{f'_c} \quad (16)$$

The capacity reduction factor is taken as 1.0,  $f'_c$  is increased by 25 percent to account for strain rate effects due to dynamic loading. If response is allowed in the elastic range of the slab then  $P = 1/2R$ . Substituting this and other slab parameters into equation (14) it can be shown that the uniformly applied dynamic load ( $q_y$ ) of long duration required to produce shear failure of a square two-way slab without web reinforcement, fixed on four sides is given by the following expression

$$q_y = \frac{v_c (a - d) d}{0.4 a^2} \quad (17)$$

where  $v_c$  is given by equation (16)

$a$  is the slab span, in

$d$  is the effective depth of the slab, in

If response is allowed into the plastic range, then  $P = \alpha R_m$  where  $\alpha = 1 - 1/2\mu$ . Substituting this and other slab parameters into equation (15) it can be shown that the uniformly applied dynamic load of long duration required to produce shear failure of a square, two-way slab without web reinforcement, fixed on four sides is given by the following expression.

$$q_u = \frac{v_c (a - d) d}{(0.09 + 0.16/\alpha)a^2} \quad (18)$$

Using these expressions with appropriate geometric and material properties, dynamic loads required to produce shear failure for the three slabs are given.

TABLE 12. DYNAMIC SHEAR CAPACITY

	$q_y$ , psi(kPa)	$q_u$ , psi(kPa)
Interior Panel	5.14 (35.44)	8.44 (58.19)
Exterior Panel	5.14 (35.44)	8.42 (58.05)
Corner Panel	5.14 (35.44)	8.41 (57.98)

2.2.2.4 Load Carrying Capacity of Edge Beams: Steel beams supporting the slabs are W16x31. They can fail either in flexure, shear of the beam or shear failure at the connections. Assuming uniform distribution of load applied to the slab, then each interior beam carries the equivalent of one-half slab area. Using analysis procedures similar to those described in connection with slab analysis, the dynamic load carrying capacity of the beams and connections were determined based on the following criteria.

$\sigma_{yp}$  = yield strength of steel in flexure = 36,000 psi

$v_{yp}$  = yield strength of steel in shear = 21,000 psi

$M_p$  = plastic moment of W16x31 = 162 k-ft

Corresponding results are given as: Uniform dynamic load of long duration required to produce flexural yielding,  $p_y = 0.65$  psi.



Uniform dynamic load of long duration required to produce collapse due to flexure,  $p_u = 1.25$  psi (8.62kPa). Corresponding values based on shear failure are  $q_y = 6.4$  psi (44.13kPa) = 11.23 psi (77.43kPa).

2.2.2.5 Resistance of Beam to Column Connections: The minimum resistance of the beam to column connection was found to be 26.5k which represents the shear capacity of the fastener group. Translated to uniformly applied dynamic load of long duration, this amounts to 0.92 psi(6.34kPa).

2.2.2.6 Resistance of Interior Columns: The buckling criteria used herein is based on static loading only. The actual process of buckling takes a finite period of time, since the member must accelerate laterally and the mass of the member provides an inertial force retarding this acceleration. For this reason it is felt that loads that might otherwise cause failure may be applied to members for very short durations if they are removed before buckling has occurred. Fairly little information is currently available on dynamic buckling. Some work has been done on compression members, however practically nothing on beams and on columns subjected to bending and axial loads. For these reasons, the following criteria (Ref. 28) for static loads is used.

$$F_a = 41,600 - 200 \frac{K\ell}{r} \quad (19)$$

where  $K$  is the column length factor

$\ell$  is the column length

$r$  is the radius of gyration

Columns used are W14x119,  $\ell = 10$  ft,  $r = 3.75$  in,  $K = 1.0$ , i.e., the column is assumed pinned at both ends. With these data,  $F_a = 35,200$  psi which results in an upper bound axial load of 1,540k. The dead load carried by the column is 350k. The live load on the column is assumed to be produced by dynamic shear of the edge beams supporting the ground floor. In the plastic range the dynamic shear for a simply supported beam is (Ref. 20)

$$V = 0.38 R_m + 0.12 F \quad (20)$$

Assuming that  $\mu = 26$  (Ref. 22), then

$$F = R_m \left(1 - \frac{1}{2\mu}\right) = \frac{51}{52} R_m$$

With this, the dynamic load experienced by the column is

$$P = 4V = 4(0.51)F = 4(0.51) \frac{ws^2}{2}$$

$$w_u = \frac{(1540 - 350)}{2(0.51)s^2} = 20.25 \text{ psi}$$

where  $s$  is the edge beam span and  $w_u$  is the critical load applied to the slab surface.

Results for the as-built structure are summarized in Table 13.

2.2.3 Expedient Upgrading - To increase the blast resistance of this basement, it is necessary to:

1. Provide closures for stairwells and elevator shafts
2. Increase the structural resistance of beam-to-column connections; edge beams; and slabs.

Expedient closures for stairwells and elevator shafts that were considered in this study are shown in Figures 21 and 22. They are based on suggested concepts given in Ref. 14. Increasing the structural resistance of beam to column connections was done as indicated in Figure 23. In this concept the strength of the connection is increased by supporting each beam at its ends on 6 inch by 6 inch (0.152m by 0.152m) timbers. These are tied together with four additional 6 inch by 6 inch (0.152m by 0.152m) timbers forming built up columns. Interior edge beams are supported at their mid-spans in the manner shown in Figure 24. The slab is strengthened by providing a timber crib as shown in Figure 25 and Figure 26. The periphery of this crib is located at the approximate location where reinforcing bars are bent up.

TABLE 13. FAILURE OVERPRESSURES FOR AS-BUILT STRUCTURE

Structural Member	Mode of Failure	Buckling		Flexure			Shear		
		$P_y$ (kPa)	$P_u$ (kPa)	$P_y$ (kPa)	$P_u$ (kPa)	$q_y$ (kPa)	$q_u$ (kPa)	$q_y$ (kPa)	$q_u$ (kPa)
Interior Panel		-	2.50 (17.24)	4.84 (33.37)	5.14 (35.44)	5.14 (35.44)	8.44 (58.19)	8.44 (58.19)	8.44 (58.19)
Exterior Panel		-	2.62 (18.06)	5.06 (34.89)	5.14 (35.44)	5.14 (35.44)	8.42 (58.05)	8.42 (58.05)	8.42 (58.05)
Corner Panel		-	2.65 (18.27)	5.10 (35.16)	5.14 (35.44)	5.14 (35.44)	8.41 (57.98)	8.41 (57.98)	8.41 (57.98)
Edge Beam		-	0.65 ( 4.48)	1.25 ( 8.62)	6.40 (44.13)	6.40 (44.13)	11.23 (77.43)	11.23 (77.43)	11.23 (77.43)
Column		20.25(139.62)	-	-	-	-	-	-	-
Beam to Column Connection		-	-	-	-	-	0.92 ( 6.34)	0.92 ( 6.34)	0.92 ( 6.34)



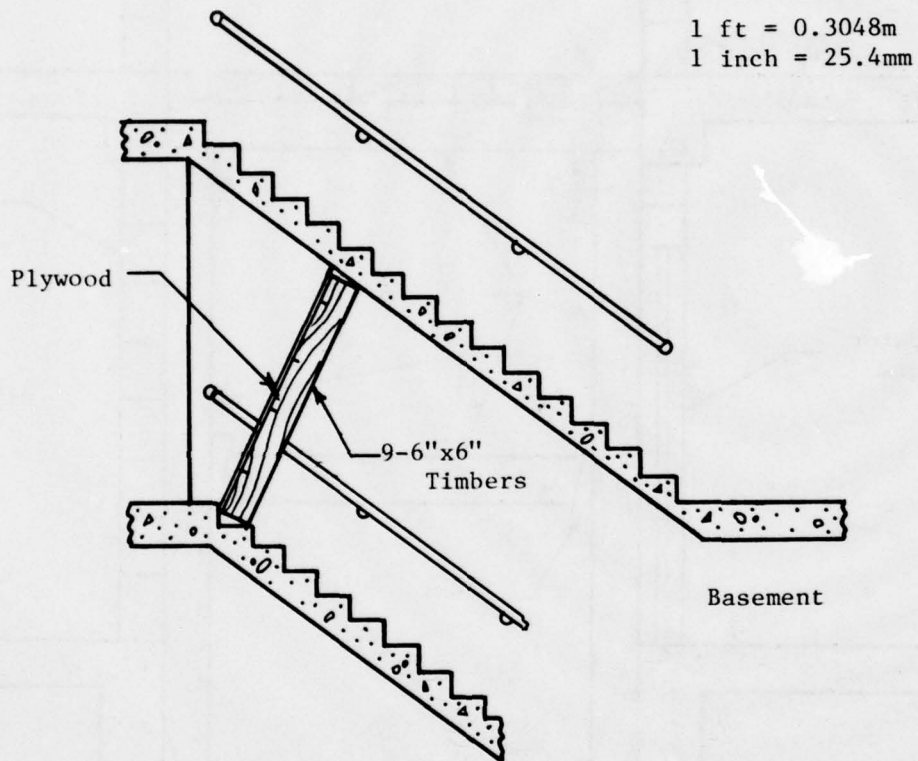

Figure 21. Expedient Basement Closure

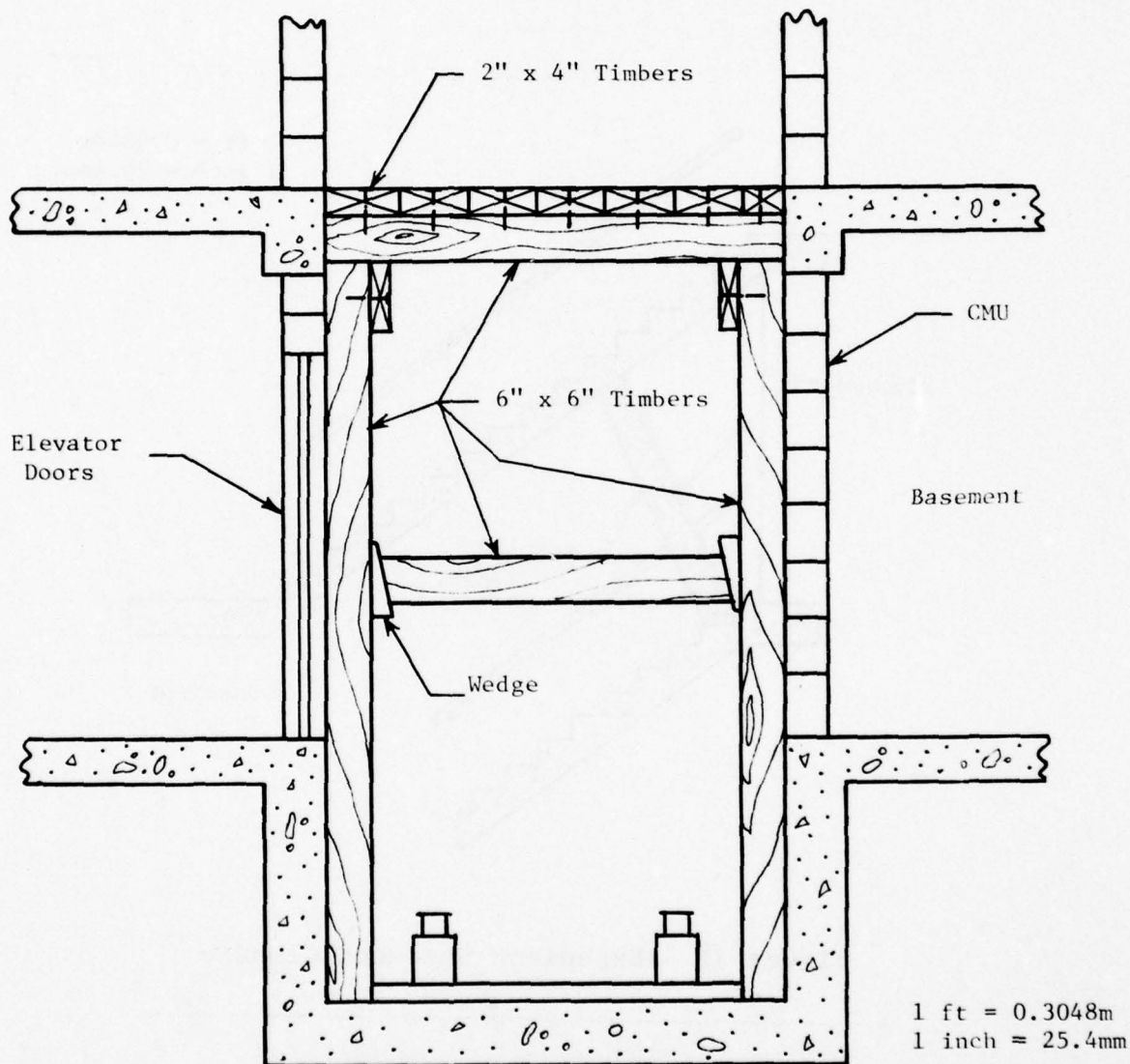
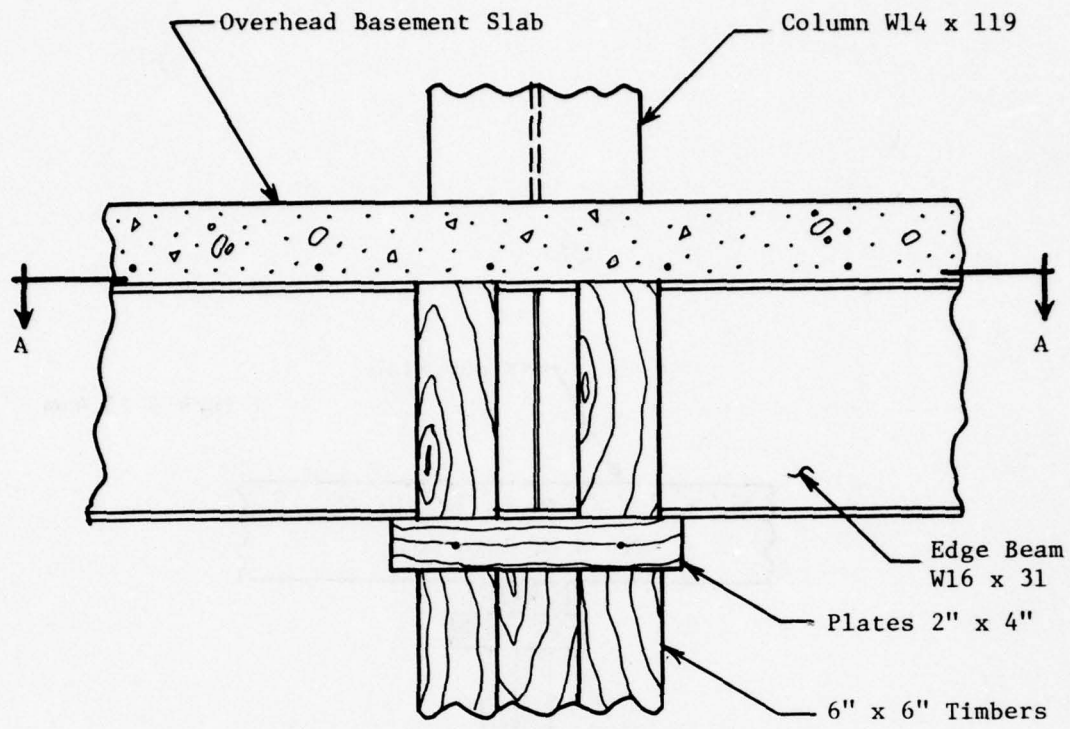
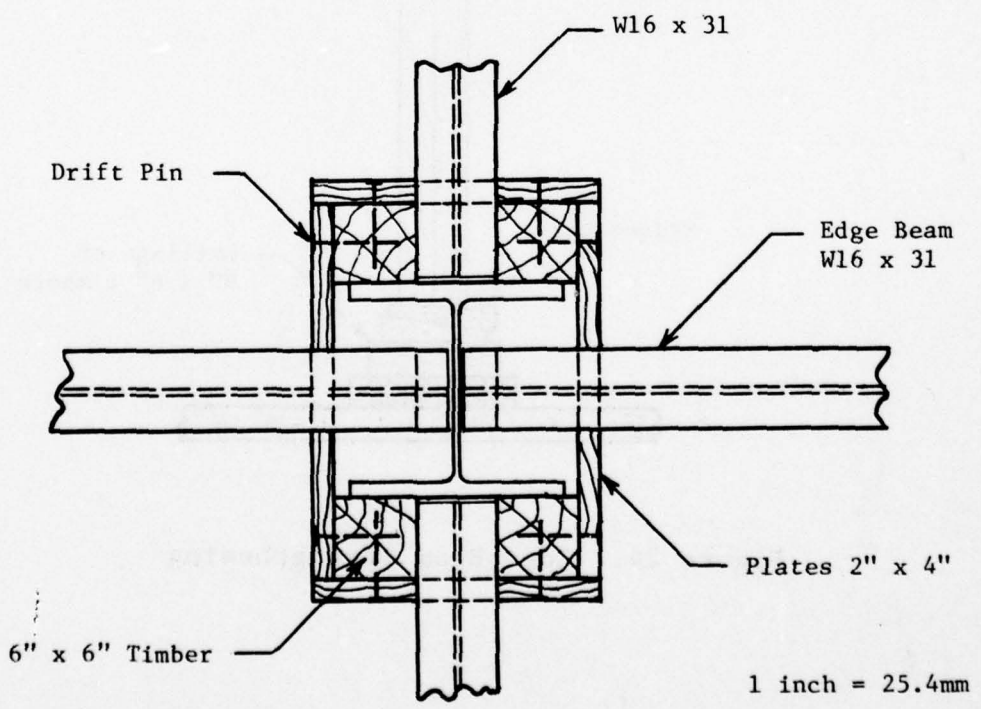

Figure 22. Expedient Blast Protection for Elevator Shaft  
(Ref. 14)



(a) Side View



(b) View A-A

Figure 23. Beam to Column Connection Upgrading Concept



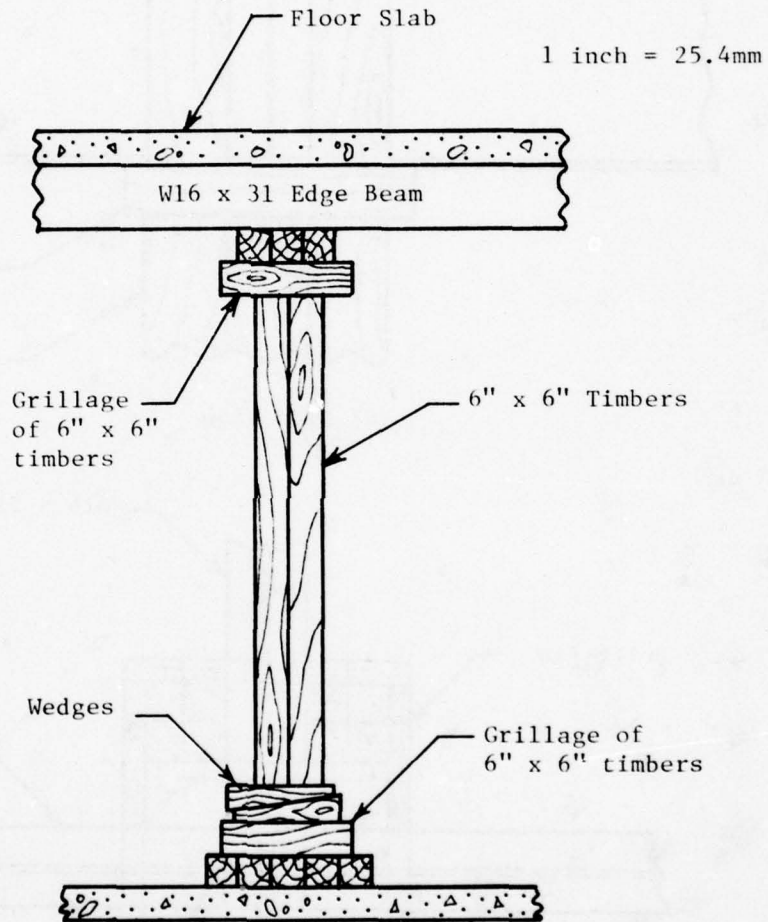

Figure 24. Edge Beam Strengthening

1 ft = 0.3048m  
1 inch = 25.4mm

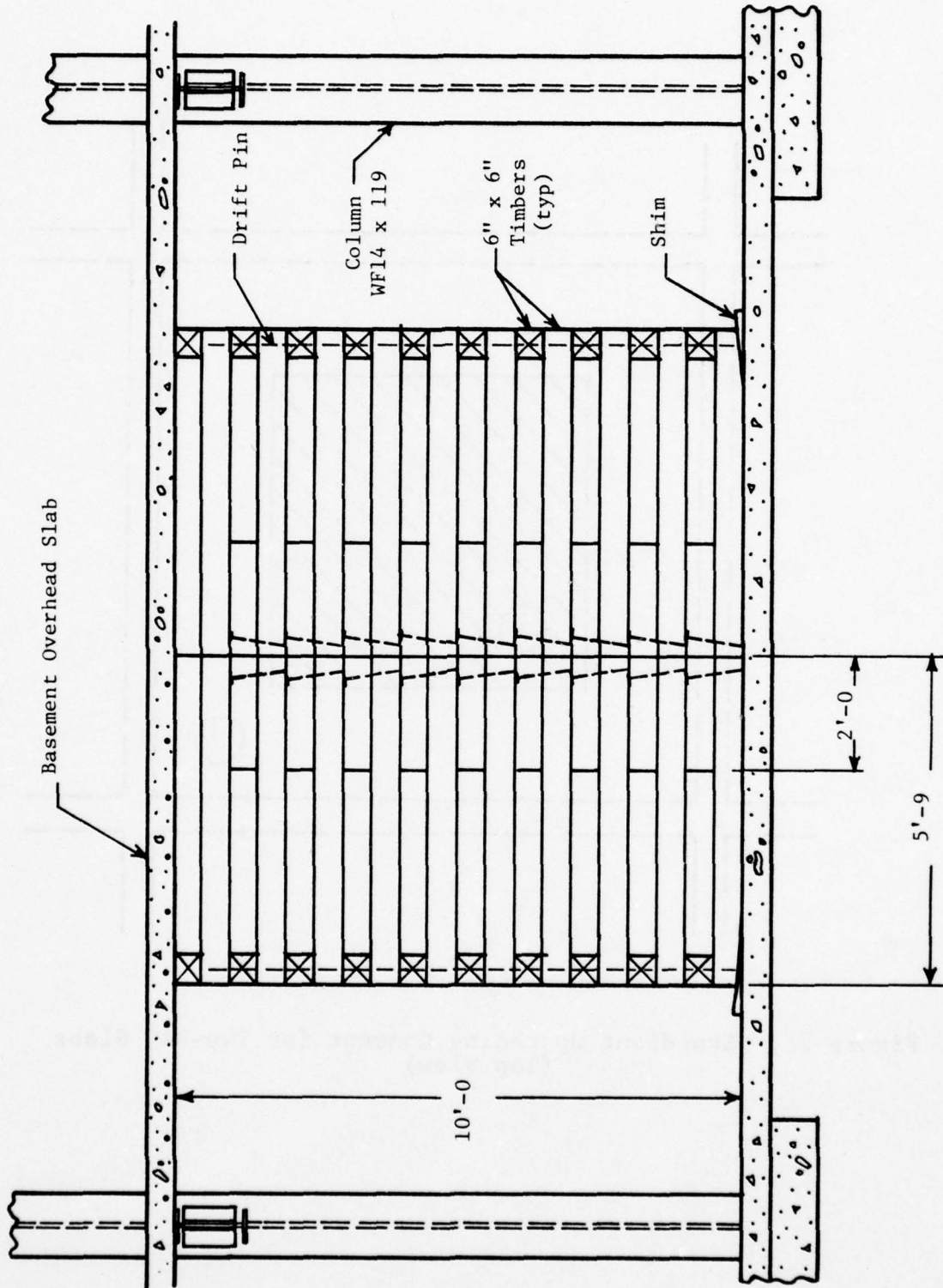

Figure 25. Expedient Upgrading Concept for Two-Way Slabs (side view)

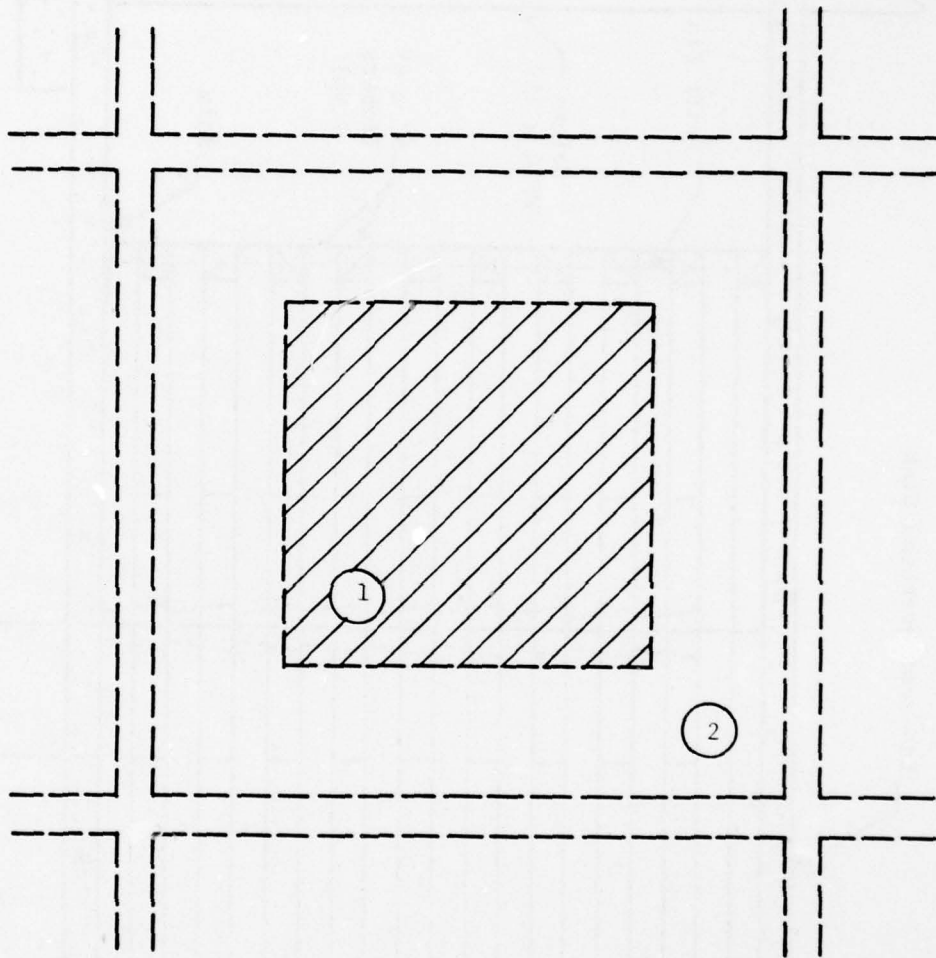

Figure 26. Expedient Upgrading Concept for Two-Way Slabs  
(Top View)



In continuous beams and slabs, the reinforcement is generally bent up or trussed. Theoretically, the bars should be bent up or down at points where they are no longer needed to resist flexural stresses. These points are the points of inflection. The general rules for bending bars are illustrated in Figure 27.

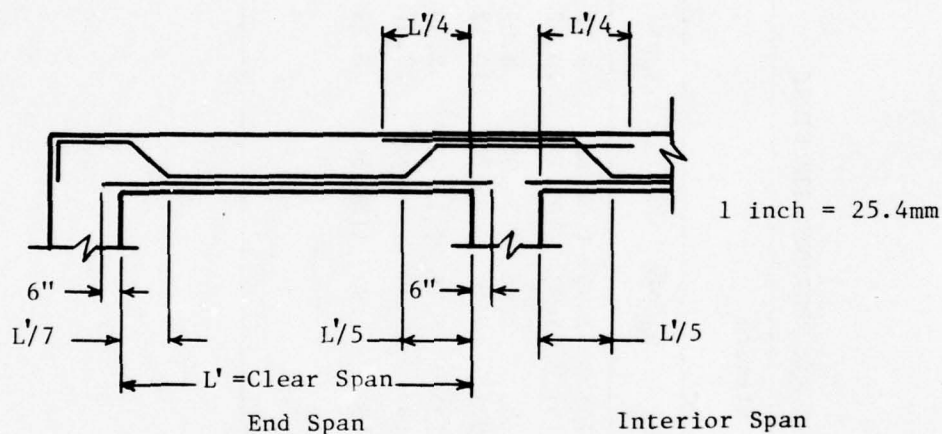

Figure 27. Reinforcement Layout

By placing a support in the area where the steel is bent up the structure is altered such that we essentially have a simply supported slab in area 1 (see Figure 26), i.e., the area enclosed by the crib, and a slab which is clamped at one end and simply supported at the other in area 2. When subjected to uniformly applied blast loading the slab is expected to crack in the vicinity of the intermediate support (since there is no negative steel) thus producing a simple support.

When upgraded in this fashion, failure overpressures for the individual structural members are as given in Table 14. These results were obtained using procedures similar to those described in connection with the as-built structure. They may be directly compared to results from the as-built structure given in Table 13.

TABLE 14. FAILURE OVERPRESSURES FOR UPGRADED STRUCTURE

Structural Member	Mode of Failure		Flexure			Shear		
	Buckling		P <sub>y</sub> psi (kPa)	P <sub>u</sub> psi (kPa)	q <sub>y</sub> psi (kPa)	q <sub>u</sub> psi (kPa)	q <sub>y</sub> psi (kPa)	q <sub>u</sub> psi (kPa)
Interior Panel - Region 1*	-		4.17 (28.75)	7.93 ( 54.68)	9.74 (67.15)	15.66 (107.97)		
	-		8.15 (56.19)	15.83 (109.14)	10.57 (72.88)	22.30 (153.75)		
Exterior Panel - Region 1	-		4.16 (28.68)	7.96 ( 54.88)	8.87 (61.16)	14.26 ( 98.32)		
	-		7.48 (51.57)	14.46 ( 99.70)	10.57 (72.88)	22.29 (153.68)		
Corner Panel - Region 1	-		4.08 (28.13)	7.75 ( 53.43)	8.90 (61.36)	14.27 ( 98.39)		
	-		8.29 (57.16)	15.99 (110.25)	10.57 (72.88)	22.25 (153.41)		
Edge Beam	-		10.36 (71.43)	19.92 (137.34)	8.29 (57.16)	14.06 ( 96.94)		
Column	46.49(320.54)		-	-	-	-		
Beam to Column Connection	-		-	-	-	-	1.37 ( 9.45)	

\* See Figure 26

A possible variation of this upgrading concept is shown in Figure 28. The slab over the crib area is strengthened by supporting it on two timber girders with a central column support. This results in four square, simply supported reinforced concrete slabs over the crib area. The span is approximately 5 ft 6 inches (1.68m). Critical overpressure levels are:

- Freefield overpressure to produce yielding - 17.69 psi(121.97kPa) (based on flexure)
- Freefield overpressure to produce collapse - 31.59 psi(217.81kPa) (based on shear)

2.2.4 People Survivability in Basement Shelter - The subject building is of framed construction with weak walls. It is not expected to offer any significant protection to upper story occupants beyond about 1.0 psi (6.89kPa). The basement is the only potentially viable shelter space, although in its as-built condition it does not appear to offer anymore protection than the upper stories (see Figure 29). The reason is due to weak beam to column connection (see Table 13). When upgraded using techniques described in the previous section, the sheltering potential increases substantially. For example, consider the scheme illustrated in Figure 30. The shelter area consists of the interior (shaded and cross-hatched) portion of the basement and includes 4800 sq ft (445.93m<sup>2</sup>). To obtain this shelter area it is necessary to provide closures for two stairwells and four elevator shafts. It is also necessary to upgrade 20 columns, 31 beams and 12 slabs. Results are shown in Figure 29. Sheltering option A refers to people being distributed in all (shaded and cross-hatched) areas of the shelter, i.e., both inside and outside of cribs. Sheltering option B refers to people being located only in the shaded areas, i.e., outside of the cribs. For sheltering options A and B the cribs are as shown in Figure 25, i.e., not reinforced (modified). Sheltering option C refers to people being located within cribs only, but the cribs are modified as shown in Figure 28. Sheltering option D refers to people being located in all areas of the shelter and the cribs are modified as in option C. This option is directly comparable to option A.



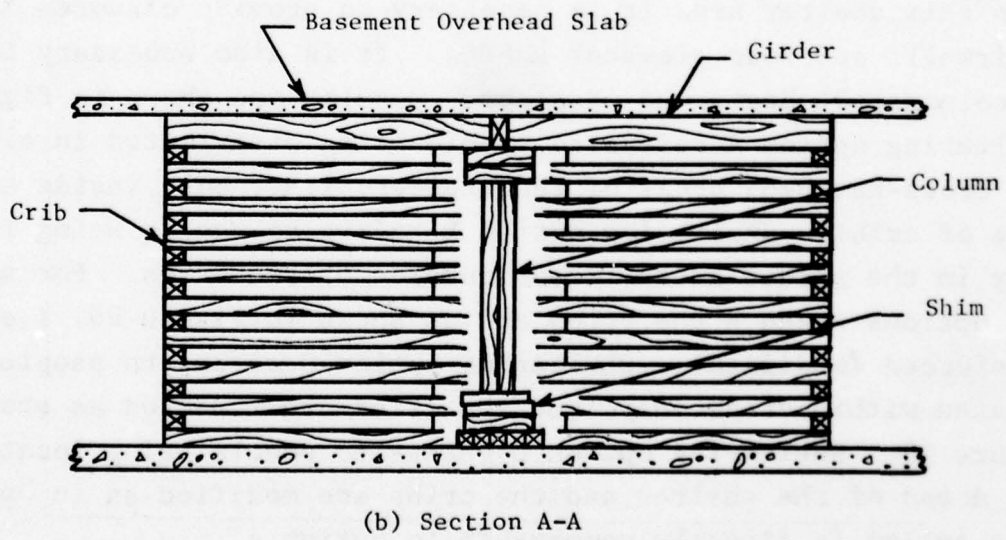
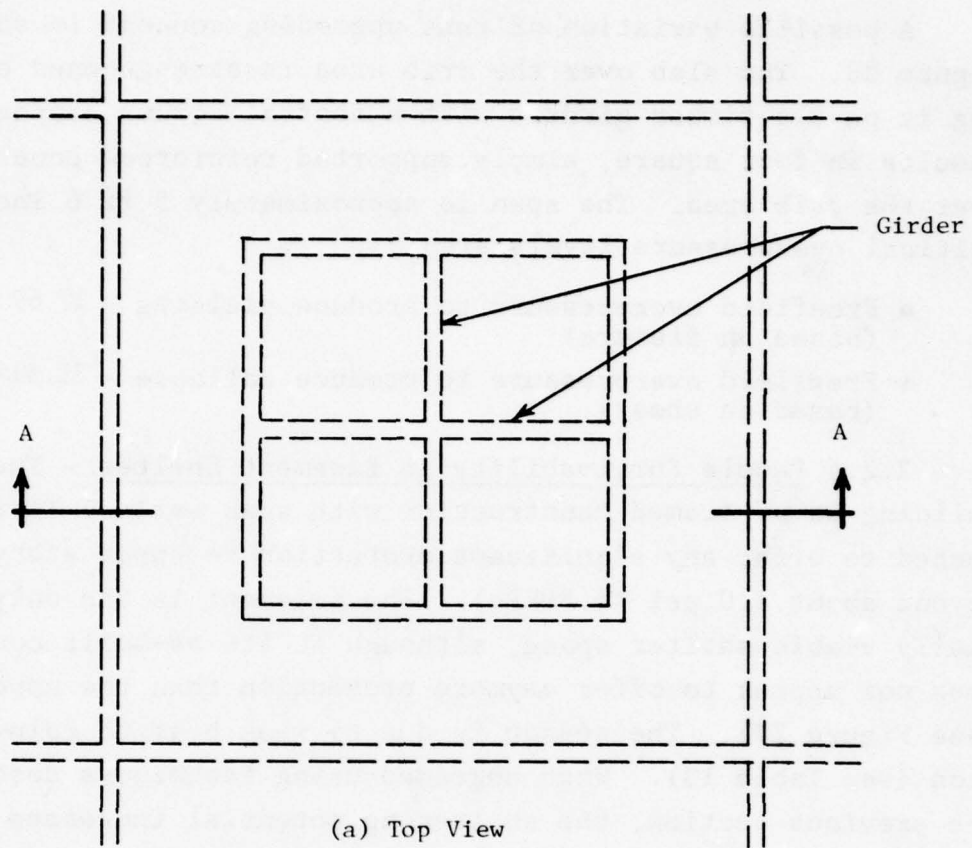

Figure 28. Expedient Upgrading Concept for Two-Way Slabs (Modified)

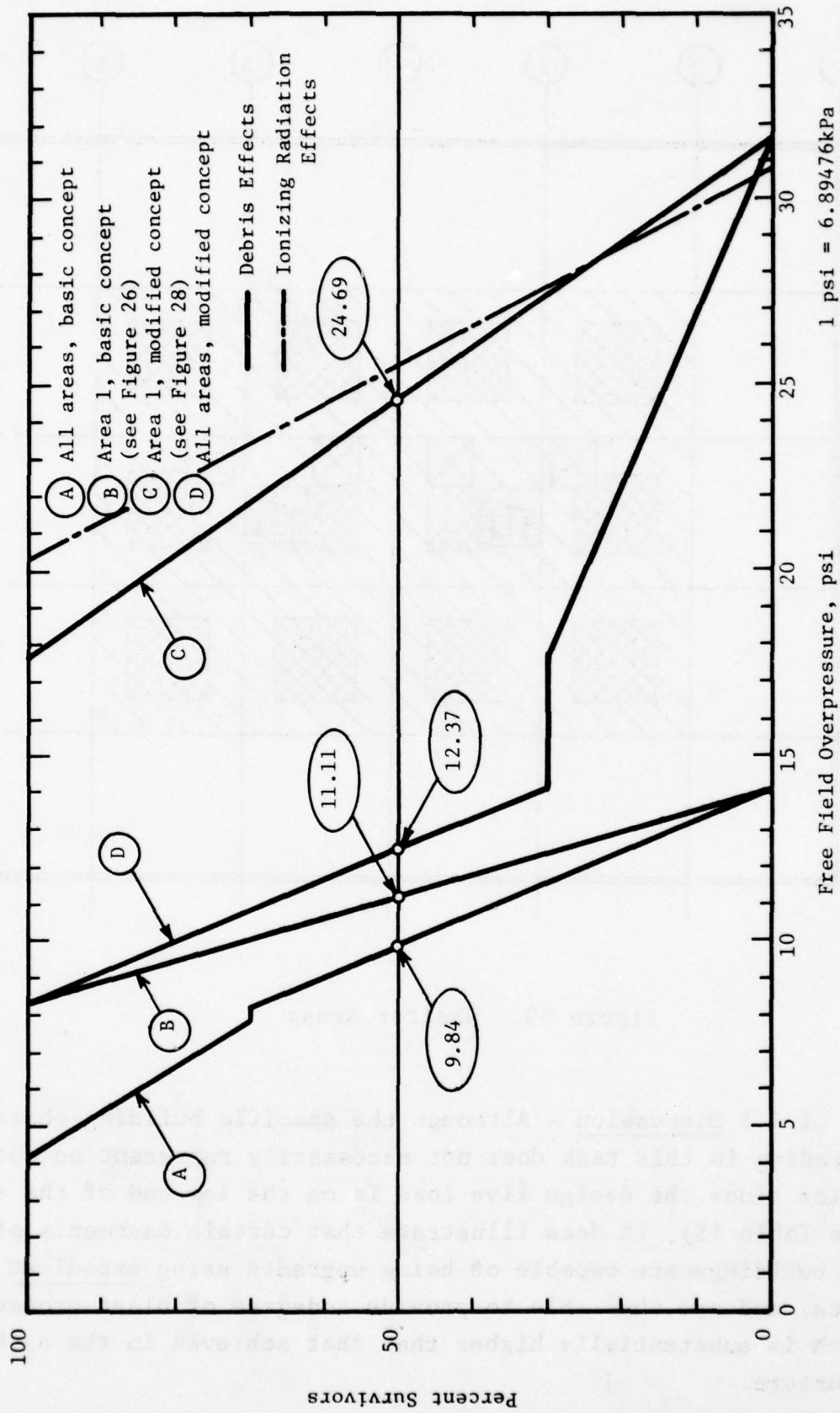

Figure 29. Estimate of People Survivability

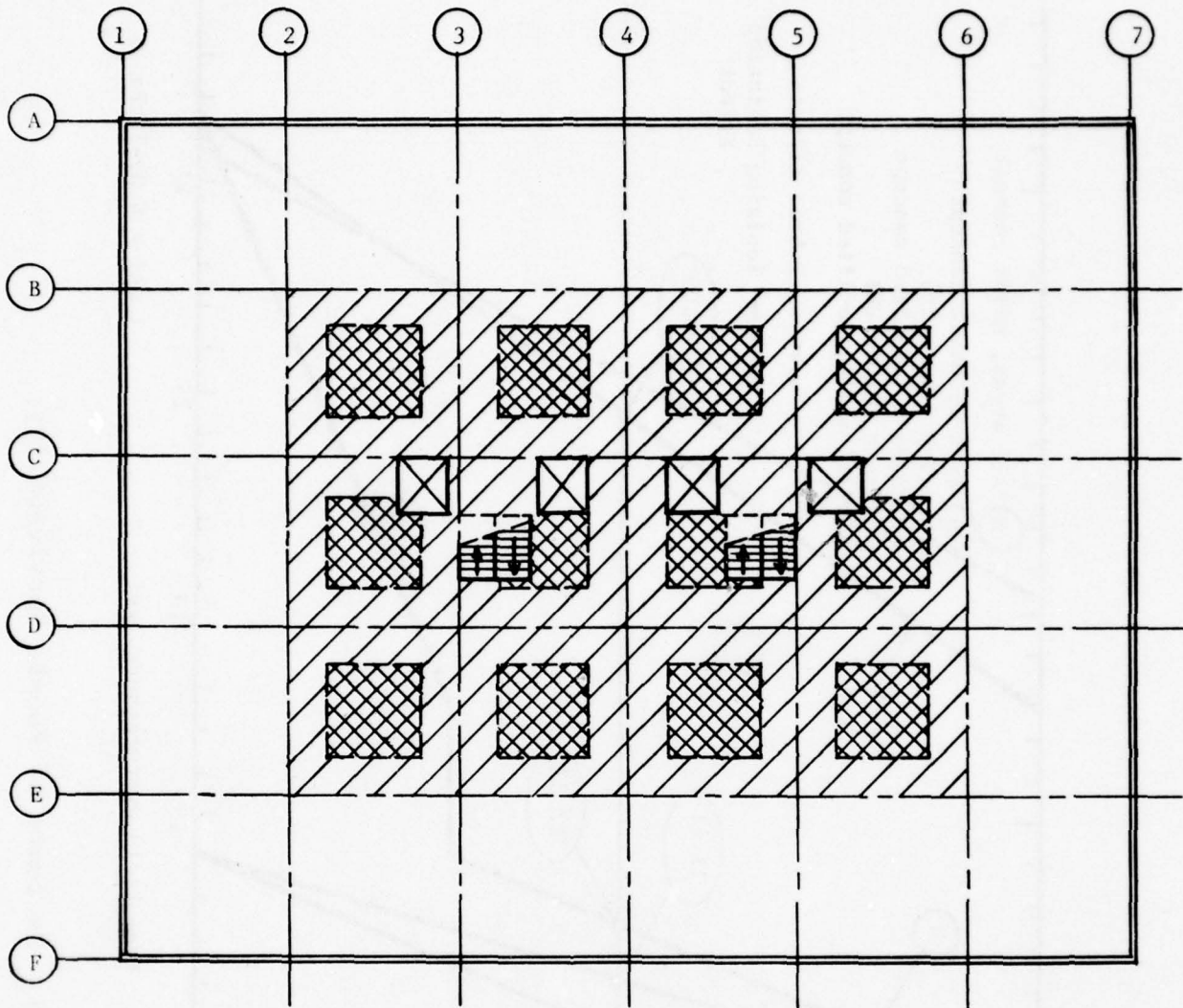

Figure 30. Shelter Areas

2.2.5 Discussion - Although the specific building chosen for upgrading in this task does not necessarily represent an optimum choice since the design live load is on the low end of the scale (see Table 15), it does illustrate that certain basements of existing buildings are capable of being upgraded using expedient measures, and are thus able to provide a degree of blast protection which is substantially higher than that achieved in the as-built structure.



TABLE 15. DESIGN LIVE LOAD AND BUILDING USE CLASSES (Ref. 27)

Design Live Load psf (kPa)	Building Use Classes
40 - 60 (1.92 - 2.87)	Hotel, guestrooms, library reading rooms, private apartments, corridors of residential buildings, classrooms
80 (3.83)	Offices
100 (4.79)	Restaurants, passenger car garages, gymnasiums, office building lobbies, hotel public rooms, school corridors, first floor areas of retail stores, theater corridors and lobbies
125 (5.99)	Manufacturing, light storage warehouses, whole-sale stores
200 - 250 (9.58 - 11.97)	Heavy storage warehouses

In an actual shelter identification and upgrading effort aimed at providing adequate shelter space for people remaining in high risk areas, the plan should be one which considers the best available structures first. In terms of design live load one would consider buildings in reverse order to that given in Table 15. Obviously, selection of buildings on the basis of live load is not the only and not necessarily the correct selection criterion. In fact, according to correlation study reported in Ref. 14 on some 50 NSS buildings the authors indicate that, .....

"The examination of the data for all available dynamic analyses of floor systems, as well as for several specific categories, showed that the predicted collapse overpressure of a floor system is dependent on a number of variables. The use of a single variable, especially the design live load, to judge the collapse strength under blast load of floor systems over basement areas of NSS buildings cannot be supported by the available analyses of floors of existing buildings". (Ref. 14).

One would need to consider other parameters such as age of the building, number of openings into the basement and their size, available shelter space, available upgrading materials, stored hazardous materials, proximity to critical industries, etc. Selection will also depend on the number of individuals needing shelter. If this number is on the order of 10 to 50 persons, then this upgrading concept shows promise even for buildings such as the apartment

building considered here. The quantity of lumber required is reduced from that needed in the sample problem (see Figure 30) discussed here and the strength of the slab is capable of being increased as illustrated in Figure 28.

Obviously the upgrading concept considered here can be modified to suit the particular need, and available materials. For example, if time and materials are available, the crib may be constructed using either bolted or welded structural steel.

### 2.3 Emergency Operating Center; Livermore, California

2.3.1 Building Description - This structure (Ref. 14) consists of an aboveground story and a fully buried basement. The overall height is about 20 ft (6.096m) and gross plan dimensions are about 60 ft (18.288m) by 60 ft (18.288m). Floor areas are about 2880 sq ft (267.56m<sup>2</sup>) on the basement level and 3166 sq ft (294.13m<sup>2</sup>) on the first story level. The basement plan is shown in Figure 31.

The building has load-bearing reinforced concrete masonry exterior and interior walls. The walls on the first story level are 8 inches (0.203m) thick, and support the tapered timber laminated beam roof system. On the basement level, the exterior walls in contact with soil are 12 inches (0.305m) thick, and all interior load-bearing walls are 8 inches (0.203m) thick. The vertical steel reinforcing in the 12 inch (0.305m) thick exterior basement walls consists of #6 reinforcing bars on 16 inch (0.406m) centers, and in the 8 inch (0.203m) thick walls of #4 bars on 24 inch (0.610m) centers; all walls also have horizontal reinforcing consisting of two #4 bars on 4 ft (1.219m) centers. The vertical steel in the basement walls is extended into their footings and into the first floor slab, and all vertical wall intersections are dowelled.

The reinforced concrete slab over the basement area is 24 inches (0.61m) to 26 inches (0.660m) thick and was designed as a one-way slab continuous over two interior support walls. The design load was the slab dead load plus a 200 psf (9.58 kPa) live load. Figure 31 shows the location of all interior load-bearing wall partitions.

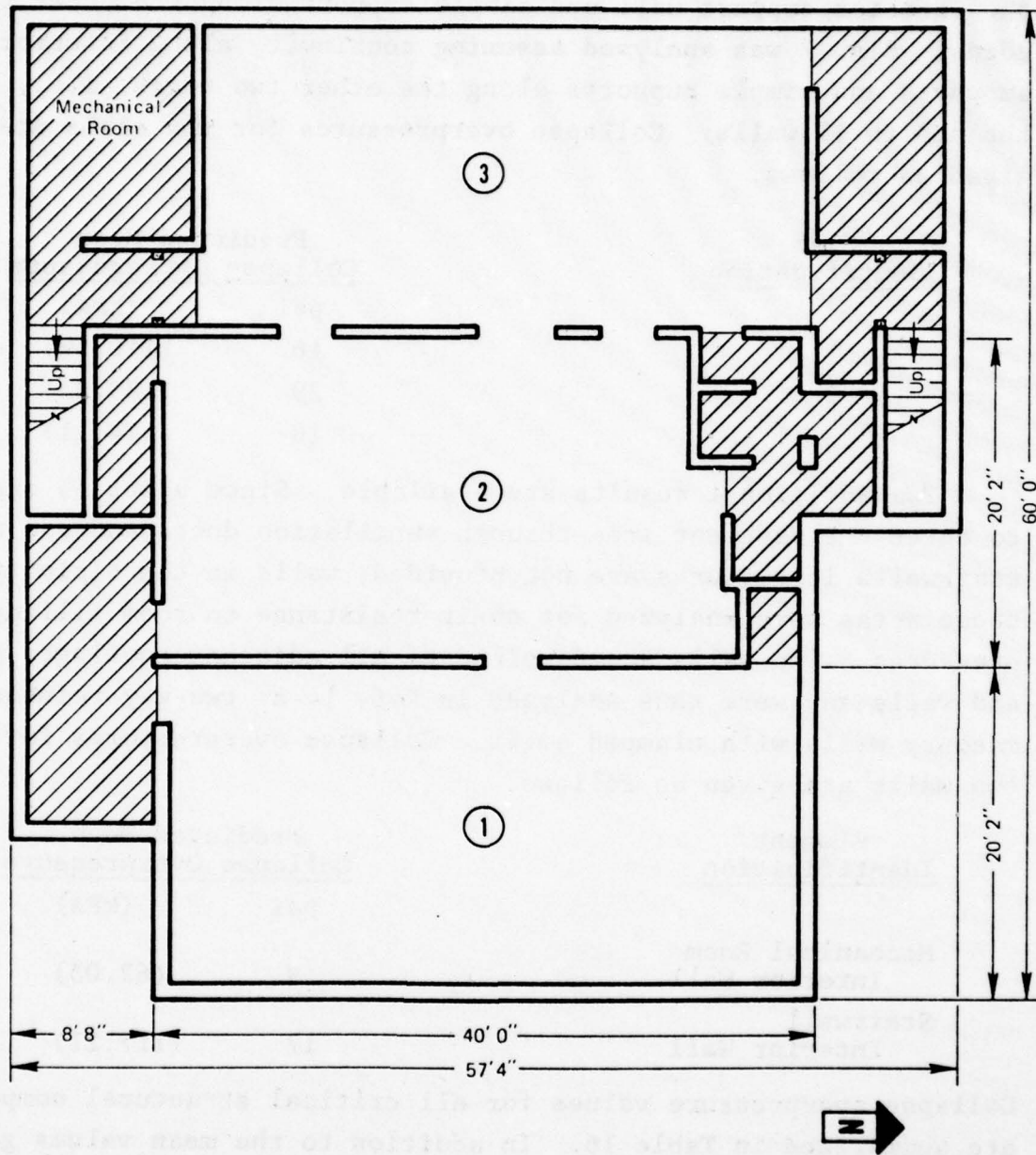

1 ft = 0.3048m  
 1 inch = 25.4mm

Figure 31. Livermore EOC Basement Floor Plan



2.3.2 Analysis of Building Components - The overhead basement slab was analyzed in Ref. 14 assuming two-way action. Slabs 1 and 3 (see Figure 31) were analyzed assuming continuity over the interior support wall and simple support along the other three edges. Slab 2 was analyzed assuming continuity along interior supports and simple supports along the other two edges, i.e., at the stairwell walls. Collapse overpressures for the slabs are given as follows.

<u>Slab Identification</u>	<u>Predicted Mean Collapse Overpressure</u>	
	psi	(kPa)
1	16	(110.32)
2	29	(199.95)
3	18	(124.11)

Two additional results are available. Since blast is expected to enter the basement area through ventilation ducts and one of the stairwells if closures are not provided, walls in the vicinity of these areas were analyzed for their resistance to room filling pressures. The walls are dowelled to all adjacent footings, slabs and walls and were thus analyzed in Ref. 14 as two-way reinforced masonry walls with clamped edges. Collapse overpressures for these two walls are given as follows.

<u>Element Identification</u>	<u>Predicted Mean Collapse Overpressure</u>	
	psi	(kPa)
Mechanical Room Interior Wall	9	(62.05)
Stairwell Interior Wall	17	(117.21)

Collapse overpressure values for all critical structural components are summarized in Table 16. In addition to the mean values given earlier, Table 16 also includes the 10 percent and the 90 percent probability values. These two sets of values were estimated in the course of this study by using the factor of  $\pm 7$  percent on the mean value. This was suggested in discussions with SRI personnel (Ref. 28).

TABLE 16. PREDICTED COLLAPSE OVERPRESSURE  
Emergency Operating Center; Livermore, California

Component Designation	10 Percent Probability Value		Mean		90 Percent Probability Value	
	psi	(kPa)	psi	(kPa)	psi	(kPa)
Slab 1	14.9	(102.73)	16	(110.32)	17.1	(117.90)
Slab 2	27	(186.16)	29	(199.95)	31	(213.74)
Slab 3	16.7	(115.14)	18	(124.11)	19.3	(133.07)
Mechanical Room Interior Wall	8.4	( 57.92)	9	( 62.05)	9.6	( 66.19)
Stairwell Interior Walls	15.8	(108.94)	17	(117.21)	18.2	(125.48)

2.3.3 Estimate of People Survivability - Based on the information provided (Ref. 14) as summarized in Table 16, a people survivability estimate was made and is presented in Figure 32. It involves the assumptions that (a) adequate and appropriate closures are provided at the ventilation ducts and at the two stairwells; (b) people are uniformly distributed in all basement areas with the exception of the stairwells. Casualty mechanisms include debris from the breakup and collapse of the overhead slab and ionizing radiation. Debris is the dominant casualty mechanism up to about 20.3 psi (139.96 kPa) after which ionizing radiation becomes dominant. A megaton range weapon is assumed.

2.3.4 Discussion of Results - Judging by the available information, this is a very desirable structure for shelter purposes. It possesses substantial inherent strength and can be easily upgraded by simply closing off its openings. Although the open shelter concept was not considered, judging by the strength of its interior walls and the number of small individual rooms it may well be a very effective shelter for a limited number of individuals. However, as an emergency operating center involving sensitive equipment, closures would be required.

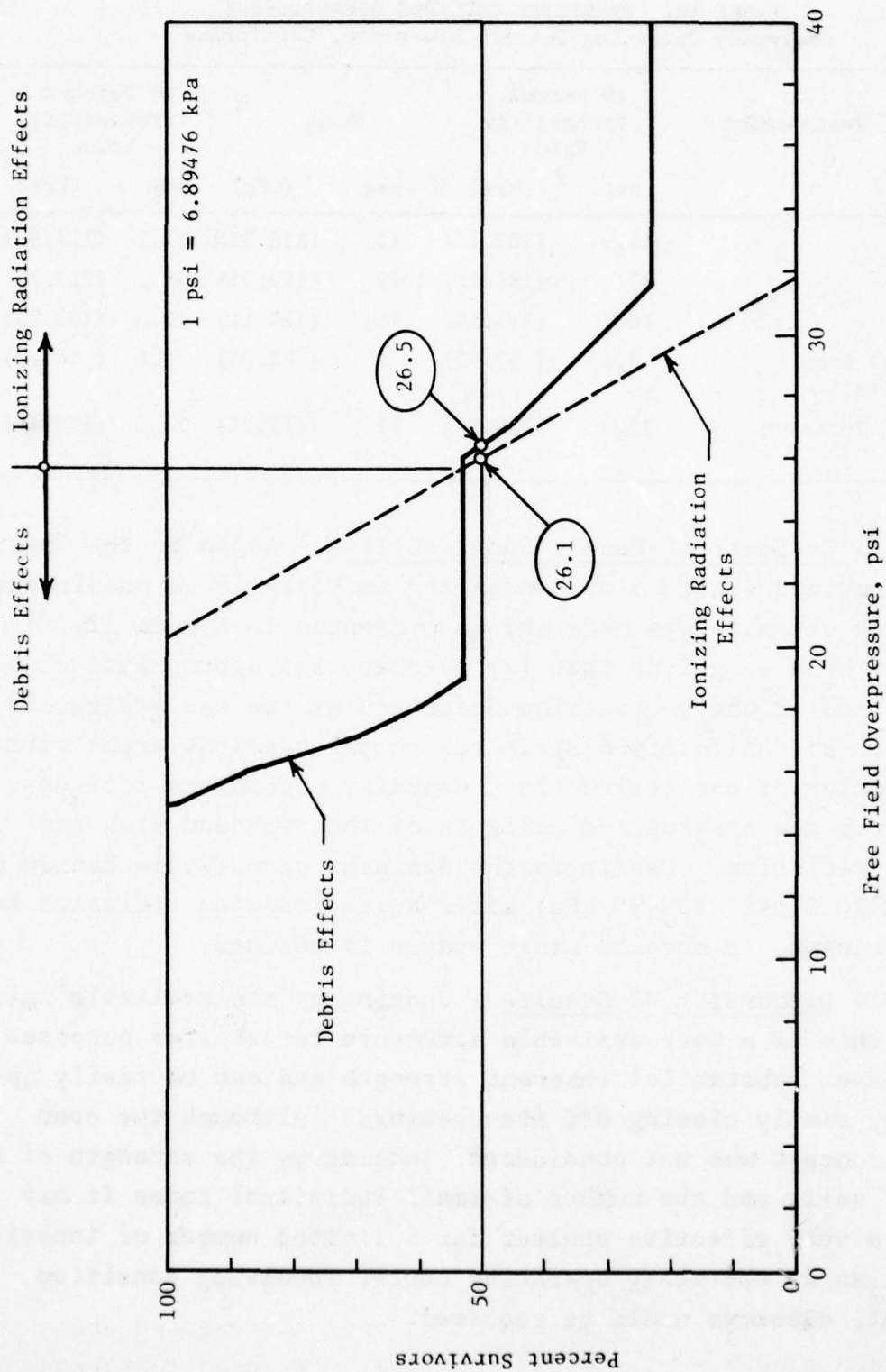

Figure 32. Estimate of People Survivability; Livermore EOC



In Figure 32 the survivability estimate is enveloped by a solid line up to about 20.3 psi (139.96 kPa) and by a dash line thereafter. People survivability is thus governed by the strength of the overhead slab up to about 20.3 psi (139.96 kPa) and by ionizing radiation thereafter. The debris envelope, represented by the solid lines, continues without reaching the zero ordinate. The reason for this is that failure overpressures provided (Ref. 16) are for basement areas 1, 2 and 3 (Figure 31). Corresponding values for slabs over the individual rooms (shown shaded in Figure 31) were not available. Collapse values over these individual rooms are expected to be higher than those given. However, to take advantage of this strength, upgrading against ionizing radiation would be a requirement. Collapse overpressures for individual closures were not available in Ref. 14. For this reason it was assumed that closures would be stronger than the critical structural components identified in Table 16.

#### 2.4 Hamilton AFB Building 424

2.4.1 Building Description - Building 424 is located on Hamilton Air Force Reserve Base, California. It consists of three stories, a basement and an attic area. The building was visited by SRI personnel (see Ref. 14) and was found to be in excellent structural condition. The building has a reinforced concrete frame. Column spacing (see Figure 33) is generally 16 ft (4.877m) center-to-center in both directions. The columns in the basement area are 16 inches (0.407m) square. The floor system on all story levels, including the attic, consists of reinforced concrete solid slabs that span between the frame beams located along all column lines. There are no intermediate slab supports between column lines. The thickness of the first story slab over the basement was estimated to be 6 inches (0.152m).

Exterior walls are constructed of concrete throughout and appear to be cast monolithically with the frame and floor slabs. The basement wall, up to the top of the first story floor slab, is 12 inches (0.305m) thick, and is about one-half exposed aboveground. Many of the exterior walls have concrete buttresses that extend

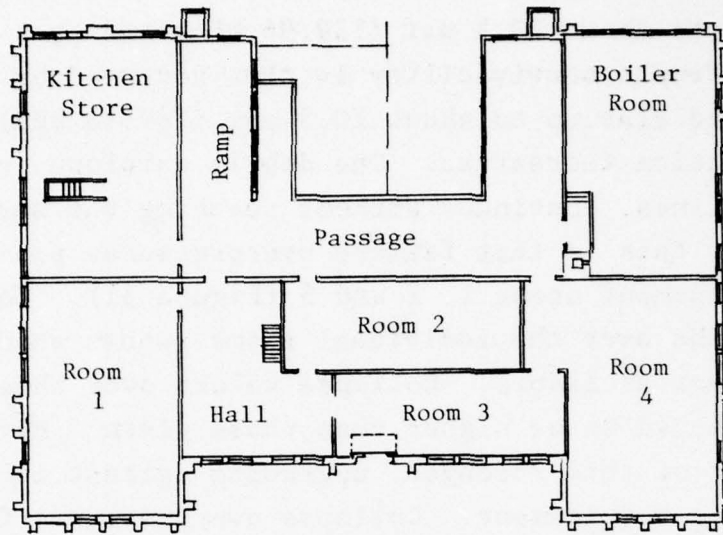

(a) Basement Floor Plan

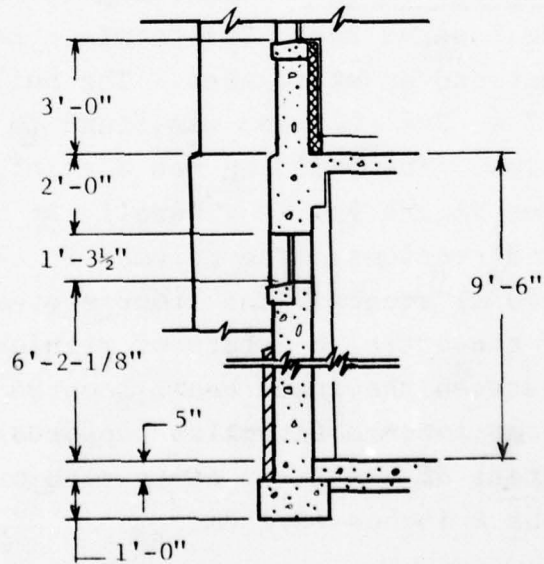

1 ft = 0.3048m  
1 inch = 25.4mm

(b) Typical Wall Section

Figure 33. Hamilton AFB Building 424 Basement Floor Plan and Typical Wall Section

almost the full height of the building. The location of interior walls as originally constructed is as shown in Figure 33a. The walls were assumed to consist of masonry tile units.

The number and size of openings into the basement is as follows (see Figure 33).

- Two stairways; kitchen about 3 ft (0.914m) wide, front entry about 4-ft (1.219m) wide
- Brick chimney, extending from the basement boiler room through the roof, measuring 4-ft-7-inch by 4-ft-8 inch (1.397m by 1.422m) outside dimensions in the attic.
- Windows, about 37 in number, each with about 16 inch by 46 inch (0.407m by 1.168m) openings and with bottom edge about 6-ft (1.829m) above basement floor
- Loading ramp (small vehicles only) and doorway about 6 ft (1.829m) wide

2.4.2 Analysis of Building Components - The first story reinforced concrete floor slabs are 6 inches (0.152m) thick and are supported on each of their four edges by beams or by a combination of beams and exterior basement walls. Since structural details were not available, the analysis performed in Ref. 14 was based on the following data based on engineering judgment and examination of similar facilities.

Span - 178 inch (4.52m)

Slab depth - 6 inch (0.152m)

$d = 4.25$  inch (0.108m), distance from extreme compression fiber to centroid of tension reinforcement

$f'_c = 2,000$  psi (13.79 MPa), compressive strength of concrete

$f_c = 800$  psi (5.52 MPa), allowable extreme fiber stress in compression

$f_s = 20,000$  psi (137.9 MPa), allowable tensile stress in reinforcement

$f_{dy} = 44,000$  psi (303.37 MPa), dynamic yield strength of reinforcement

Based on these data, the collapse overpressure the slabs was determined to be 10.1 psi (69.64 kPa).

The first story beams that support the floor slabs are 14 inches (0.356m) wide by 16 inches (0.406m) deep, including the slab thickness and span 176 inches (4.47m) between columns.



Again, structural details were not available. The approach taken in Ref. 14 was to design the beams using procedures prevalent at the time of building construction and then perform a dynamic analysis. Using materials data which were used in connection with slab analysis, the collapse overpressure for the beams was determined to be 3.6 psi (24.82 kPa).

Reinforced concrete columns supporting the floor over the basement are 16 inch (0.406m) square and there are 28 inch (0.711m) pedestals at the column bases. Using procedures outlined in Ref. 22 the column was estimated (Ref. 14) capable of resisting a blast loading on the first floor of about 16 psi (110.32 kPa). This is assumed herein to be the limiting collapse overpressure. It is concluded in Ref. 14 that footings in this building would be stronger in blast resistance than any other basement structural element.

The blast resistance of the exterior basement walls was estimated to be greater than 17 psi (117.21 kPa). It was also concluded (Ref. 14) that the collapse overpressure level of the exterior walls above the basement level would not directly affect the predicted collapse strength of the floor over the basement.

2.4.3 Expedient Upgrading - Due to the large number of openings into the basement, the "closed shelter" approach appears to be the most reasonable option. To realize this option it would be necessary to

- close off all openings
- provide intermediate supports for the beams.

According to Ref. 14, if the beams are provided with intermediate supports similar to that shown in Figure 34 then this results in an increase in dynamic resistance from 3.6 psi (24.82 kPa) to 10.5 psi (72.39 kPa) which brings it in line with the collapse strength of the slabs. The collapse strength of closures is taken to be higher than 17 psi (117.21 kPa). Specific values for the individual closures were not available at the time of this writing.

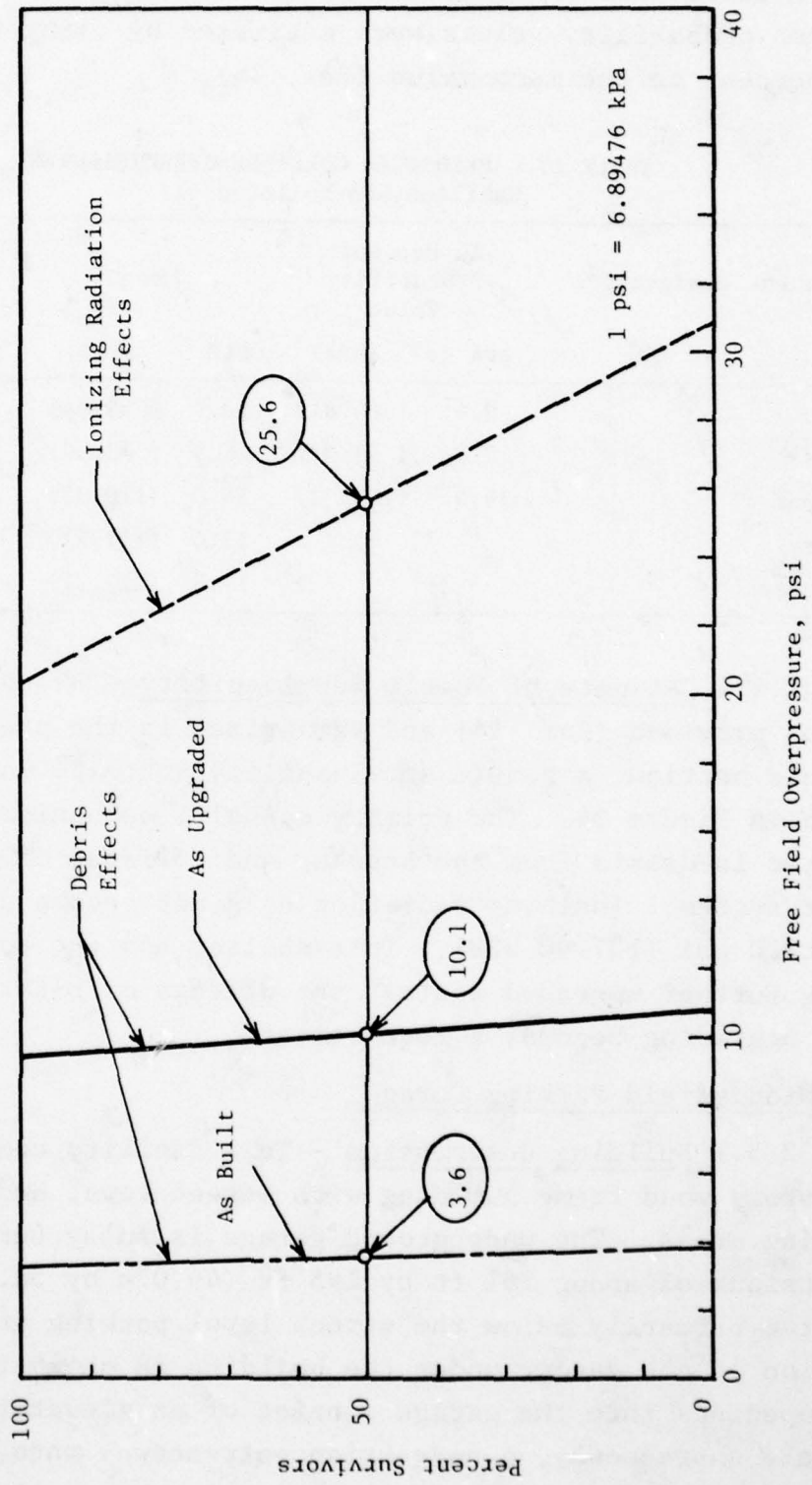

Figure 34. Hamilton AFB Building 424 People Survivability Estimate

Results discussed are summarized in Table 17. The 10 and 90 percent probability values were estimated by using the factor of  $\pm 7$  percent on the mean value (Ref. 28).

TABLE 17. PREDICTED COLLAPSE OVERPRESSURES  
Hamilton AFB Building 424

Component Designation	10 Percent Probability Value		Mean		90 Percent Probability Value	
	psi	(kPa)	psi	(kPa)	psi	(kPa)
Slabs	9.4	( 64.81)	10.1	( 69.64)	10.8	( 74.46)
Beams	9.8	( 67.57)	10.5	( 72.39)	11.2	( 77.22)
Columns	14.9	(102.73)	16.0	(110.32)	17.1	(117.90)
Walls		>	17.0	(117.21)		
Closures		>	17.0	(117.21)		

2.4.4 Estimate of People Survivability - Based on the information provided (Ref. 14) and summarized in the previous paragraphs of this section, a people survivability estimate was made and is given in Figure 34. The primary casualty mechanism for this shelter is debris from the breakup and collapse of the overhead floor system. Ionizing radiation does not become important until about 20 psi (137.90 kPa). This shelter has the potential of being further upgraded against the effects of blast, before radiation upgrading becomes a requirement.

## 2.5 Middlefield Parking Garage

2.5.1 Building Description - This facility consists of a two-story wood frame building with street level and underground parking areas. The underground garage is fully buried, has plan dimensions of about 161 ft by 195 ft (49.07m by 59.44m) and is located primarily below the street level parking area, with a small portion of the garage under the building as shown in Figure 35. The openings into the garage consist of an elevator doorway, a vehicle entranceway, a pedestrian entranceway into a stairwell leading directly into the building, and two ventilation exhaust fan openings.



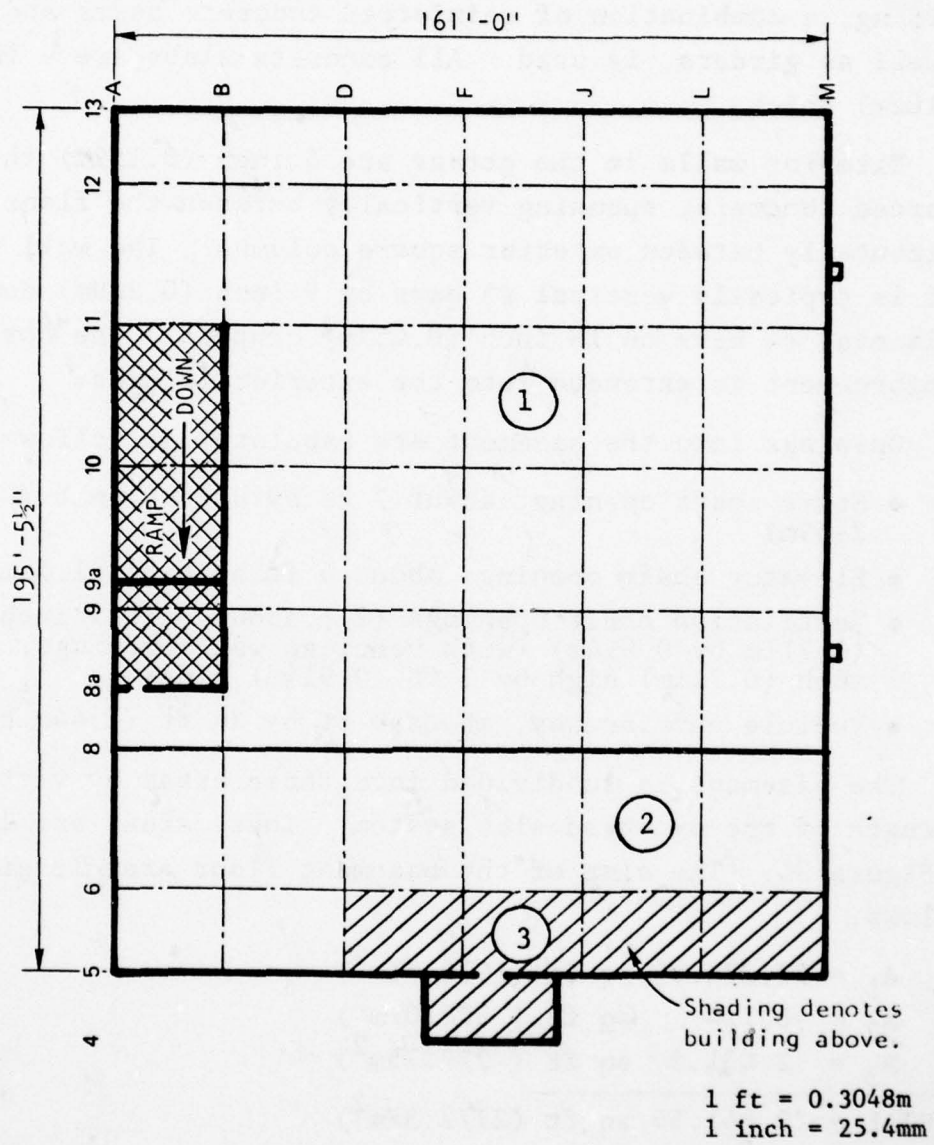

Figure 35. Plan View, Middlefield Underground Garage

The roof system over the garage consists of one-way reinforced concrete joists supported by reinforced concrete girders spanning between circular reinforced concrete columns. For the small portion of the garage roof system that also supports part of the building, a combination of reinforced concrete beams and joists, as well as girders, is used. All concrete slabs are 4 inches (0.102m) thick.

Exterior walls in the garage are 6 inch (0.152m) thick reinforced concrete, spanning vertically between the floor slabs and horizontally between exterior square columns. The wall reinforcement is typically vertical #5 bars on 9 inch (0.229m) centers, and horizontal #4 bars on 18 inch (0.457m) centers. The horizontal reinforcement is extended into the exterior columns.

Openings into the basement are tabulated as follows:

- Stair shaft opening, about 7 ft by 8 ft-6 inch (2.13m by 2.59m)
- Elevator shaft opening, about 5 ft by 6 ft (1.52m by 1.83m)
- Ventilation shaft openings (2), about 2 ft-4 inch by 3 ft (0.711m by 0.914m) (with vertical wall openings, 2 ft-4 inch (0.711m) high by 3 ft (0.914m) wide)
- Vehicle entranceway, about 8 ft by 24 ft (2.44m by 7.32m)

The basement is subdivided into three areas by virtue of the strength of the overhead slab system. These areas are identified in Figure 35. The size of the basement floor area is given as follows.

$$\begin{aligned} A_1 &= 21,276.06 \text{ sq ft } (1976.61\text{m}^2) \\ A_2 &= 6,114. \text{ sq ft } ( 578.01\text{m}^2) \\ A_3 &= 2,451.5 \text{ sq ft } ( 227.75\text{m}^2) \\ \hline \text{TOTAL} &= 29,841.56 \text{ sq ft } (2772.37\text{m}^2) \end{aligned}$$

The cross-hatched area, i.e., the ramp and elevator, was not considered as feasible for sheltering purposes and therefore their corresponding floor area is not included in the quantities given above.

2.5.2 Analysis of Structural Components - Structural components that were considered as primary by the analysts (Ref. 14) from the sheltering point of view, included the joists and the girders of the overhead slab system. Their collapse overpressures based on a megaton range nuclear weapon are given (Ref. 14) as follows. The 10 percent and the 90 percent probability values were estimated by using the factor of  $\pm 7$  percent on the mean value (Ref. 28).

TABLE 18. PREDICTED COLLAPSE OVERPRESSURE  
Middlefield Parking Garage (As-Built Structure)

	Area (see Figure 35)	10 Percent Probability Value		Mean		90 Percent Probability Value	
		psi	(kPa)	psi	(kPa)	psi	(kPa)
Joist	1	3.4	(23.44)	3.6	(24.82)	3.9	(26.89)
	2	5.5	(37.92)	5.9	(40.68)	6.3	(43.44)
	3	5.0	(34.47)	5.4	(37.23)	5.8	(39.99)
Girder	1	3.3	(22.75)	3.5	(24.13)	3.8	(26.20)
	2	4.0	(27.58)	4.3	(29.65)	4.6	(31.72)
	3	7.2	(49.64)	7.7	(53.09)	8.2	(56.54)

It is indicated in Ref. 14 that the roof system slabs, columns, and footings, as well as all reinforced concrete walls, are considerably stronger than the roof joists and girders.

2.5.3 Expedient Upgrading - Two schemes of upgrading in a closed shelter mode were considered (Ref. 14) and are described as follows.

The first scheme would include strengthening all joists by providing a line of midspan supports. This could be in the form of girders supported on columns or walls consisting of concrete block, timber or some similar combination of available materials.



The second scheme would be the same as the first except that in this case the girders would also be strengthened either by timber cribs, columns or some similar combination of available materials. Collapse overpressures corresponding to the two schemes are given as follows.

TABLE 19. PREDICTED COLLAPSE OVERPRESSURE  
Middlefield Parking Garage (Upgraded Structure)

	Area	10 Percent Probability Value		Mean		90 Percent Probability Value		
		psi	(kPa)	psi	(kPa)	psi	(kPa)	
Scheme 1	Joist	1	8.7	( 59.98)	9.4	( 64.81)	10.0	( 68.95)
		2	14.3	( 98.60)	15.3	(105.49)	16.4	(113.07)
		3	13.1	( 90.32)	14.0	( 96.53)	15.0	(103.42)
	Girder	1	6.5	( 44.82)	7.0	( 48.26)	7.5	( 51.71)
		2	8.0	( 55.16)	8.6	( 59.29)	9.2	( 63.43)
		3	14.3	( 98.60)	15.4	(106.18)	16.5	(113.76)
Scheme 2	Joist	1	8.7	( 59.98)	9.4	( 64.81)	10.0	( 68.95)
		2	14.3	( 98.60)	15.3	(105.49)	16.4	(113.08)
		3	13.1	( 90.32)	14.0	( 96.53)	15.0	(103.42)
	Girder	1	8.5	( 58.61)	9.1	( 62.74)	9.7	( 66.88)
		2	10.4	( 71.71)	11.2	( 77.22)	12.0	( 82.74)
		3	18.6	(128.24)	20.0	(137.90)	21.4	(147.55)

2.5.4 Estimate of People Survivability - Based on the information summarized in the previous section, a people survivability analysis was made and is given in Figure 36. Weapon effects that were considered important in producing casualties in the case of the as-built structure included debris from the breakup and collapse of the overhead slab plus dynamic pressures since closures are not provided for this option. Expedient upgrading includes closures and provides for strengthening of joists in the case of

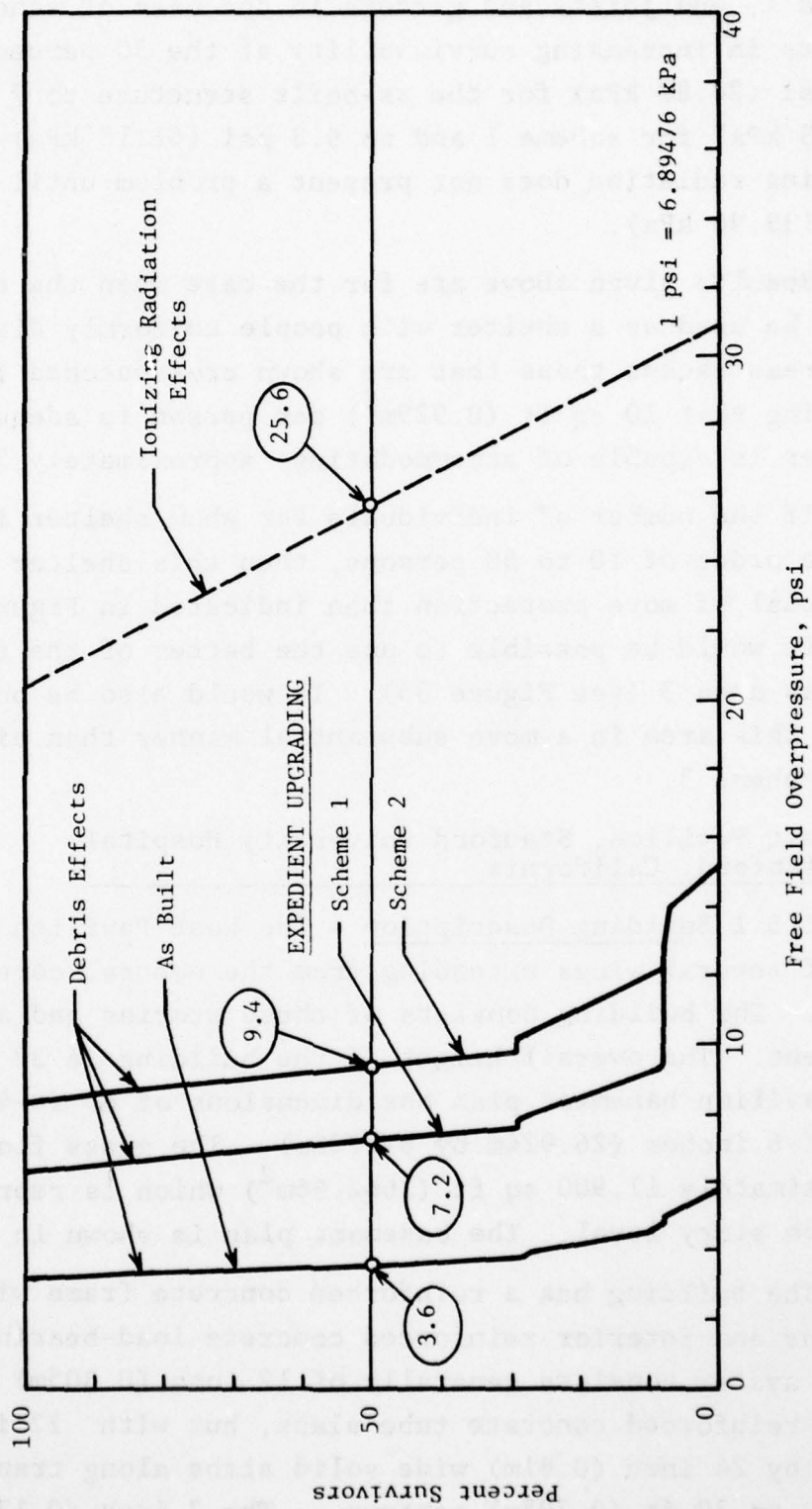

Figure 36. Middlefield Parking Garage People Survivability Estimate

scheme 1, and joists and girders in the case of scheme 2. This results in increasing survivability at the 50 percent level from 3.6 psi (24.82 kPa) for the as-built structure to 7.3 psi (50.33 kPa) for scheme 1 and to 9.3 psi (61.15 kPa) for scheme 2. Ionizing radiation does not present a problem until about 20.3 psi (139.96 kPa).

Results given above are for the case when the entire basement would be used as a shelter with people uniformly distributed in all areas except those that are shown crosshatched in Figure 35. Assuming that 10 sq ft ( $0.929\text{m}^2$ ) per person is adequate, this shelter is capable of accommodating approximately 300 persons.

If the number of individuals for whom shelter is required is on the order of 10 to 50 persons, then this shelter offers the potential of more protection than indicated in Figure 36. In this case it would be possible to use the better of the three areas, such as area 3 (see Figure 35). It would also be possible to upgrade this area in a more substantial manner than either scheme 2 or scheme 3.

## 2.6 West Pavilion, Stanford University Hospital, Stanford, California

2.6.1 Building Description - The West Pavilion (Ref. 14), is one of several wings extending from the central core of the hospital. The building consists of three stories and a fully buried basement. The overall height of the building is 38 ft (11.582m). The pavilion basement plan has dimensions of 88 ft-4 inches by 202 ft-6 inches (26.924m by 61.722m). The gross floor area is approximately 17,900 sq ft ( $1662.96\text{m}^2$ ) which is representative of each story level. The basement plan is shown in Figure 37.

The building has a reinforced concrete frame with exterior columns and interior reinforced concrete load-bearing walls. The floor system consists generally of 12 inch (0.305m) thick, transverse reinforced concrete tube slabs, but with 12 inch (0.305m) thick by 24 inch (0.61m) wide solid slabs along transverse column lines on 22 ft (0.305m) centers. The 7 inch (0.178m) diameter tubes are on 10 inch (0.254m) centers. The 12 inch (0.305m) thick



tube slabs span between the exterior walls, and are continuous over three reinforced concrete interior walls which are 10 inches (0.254m) thick.

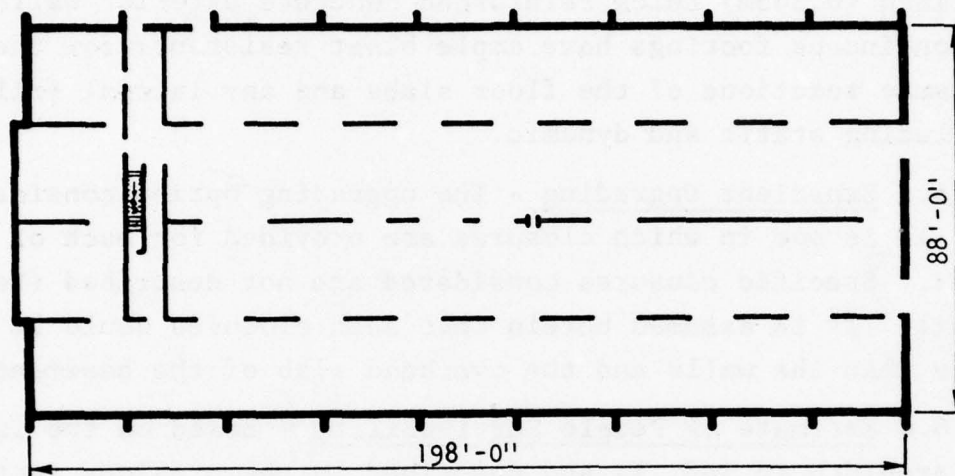

Note: All interior walls shown are 10 inches (0.254m) thick reinforced concrete

Figure 37. West Pavilion Basement Plan

The basement interior partitions are constructed of 10 inch (0.254m) thick reinforced concrete, 6 inch (0.152m) thick concrete block, and 4 inch (0.102m) thick timber stud walls. All exterior basement walls are 12 inch (0.305m) thick reinforced concrete.

Openings into the basement consist of (1) one exterior doorway leading into an areaway with dimensions of about 4 ft-3 inches by 7 ft (1.295m by 2.134m); (2) one stair shaft opening which in the horizontal plane has dimensions of about 3 ft-6 inches by 15 ft (1.067m by 4.572m); (3) two corridor openings, 8 ft by 12 ft (2.438m by 3.658m) leading from the pavilion into the building central core. The basement wing has no exterior windows.

2.6.2 Analysis of Basement Components - A structural analysis was performed in Ref. 14 and the following is reported. The dynamic analysis of the slab indicated a predicted mean collapse

overpressure of 10.7 psi (73.77 kPa). A static analysis of the 10 inch (0.254m) thick interior reinforced concrete support walls and their continuous footings showed that they would satisfactorily support the maximum dynamic reactions of the floor slabs at the 10.7 psi (73.77 kPa) overpressure level. It is also stated that the 12 inch (0.305m) thick reinforced concrete exterior walls and their continuous footings have ample blast resistance for the maximum dynamic reactions of the floor slabs and any lateral soil loading including static and dynamic.

2.6.3 Expedient Upgrading - The upgrading option considered in Ref. 14 is one in which closures are provided for each of the openings. Specific closures considered are not described (Ref. 14) in detail. It is assumed herein that such closures would be stronger than the walls and the overhead slab of the basement.

2.6.4 Estimate of People Survivability - Based on the information provided in Ref. 14 and described in the previous sections, a people survivability estimate was made and is given in Figure 38. Debris from the breakup and collapse of the overhead basement slab was the only mechanism considered important in producing casualties. The 10 percent and the 90 percent probability values were estimated by using the factor of  $\pm 7$  percent on the mean value (Ref. 28).

This basement offers the potential of being further upgraded. To do so would require supports for the overhead slab. The type and extent of such supports, i.e., the quantity of material required, would depend on the number of people being sheltered.

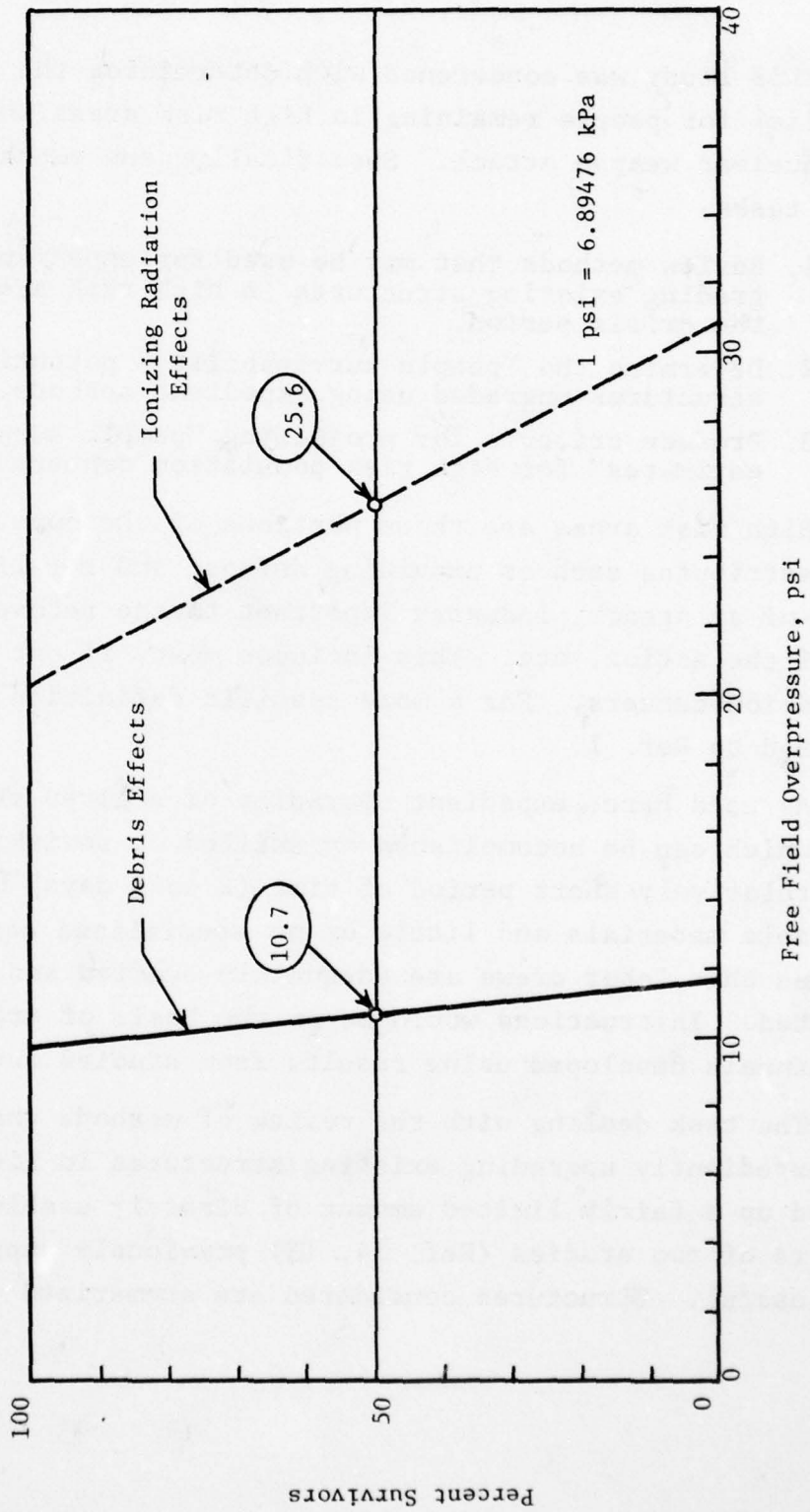

Figure 38. West Pavilion, Stanford University Hospital, Basement People Survivability Estimate



### 3. SUMMARY, CONCLUSIONS, AND RECOMMENDATIONS

This study was concerned with determining the survivability potential for people remaining in high risk areas when subjected to a nuclear weapon attack. Specifically, the emphasis was on three tasks:

1. Review methods that may be used for expediently upgrading existing structures in high risk areas during the crisis period.
2. Determine the "people survivability" potential of structures upgraded using expedient methods.
3. Produce criteria for projecting "people survivability estimates" for high risk population centers.

High risk areas are those portions of the country which possess attributes such as providing defense and retaliation in the event of an attack, industry important to the recovery and viability of the nation, etc. This includes most, if not all, large population centers. For a more specific definition the reader is referred to Ref. 1.

As used here, expedient upgrading of a given structure is a task which can be accomplished by skilled or semiskilled personnel in a relatively short period of time (2 to 3 days) using readily available materials and little or no specialized equipment. This assumes that labor crews are adequately staffed and properly instructed. Instructions would be on the basis of training courses and manuals developed using results from studies such as this one.

The task dealing with the review of methods that may be used for expediently upgrading existing structures in high risk areas turned up a fairly limited amount of directly usable information. Results of two studies (Ref. 14, 15) previously supported by DCPA were useful. Structures considered are summarized as follows.

AD-A055 764

IIT RESEARCH INST CHICAGO ILL  
SURVIVABILITY IN CRISIS UPGRADED SHELTERS.(U)  
FEB 78 A LONGINOW  
IITRI-J6390-F

F/G 13/13

UNCLASSIFIED

DCPA01-76-C-0321  
NL

2 OF 2  
ADA  
055764

U.S. GOVERNMENT PRINTING OFFICE

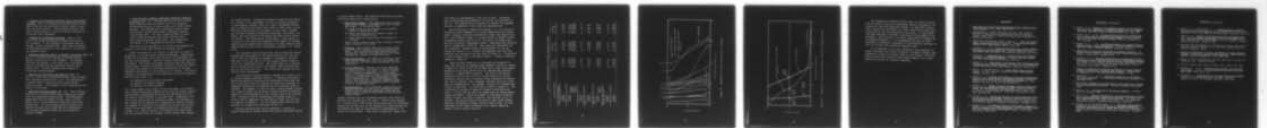

END  
DATE  
FILMED  
8 -78  
DDC

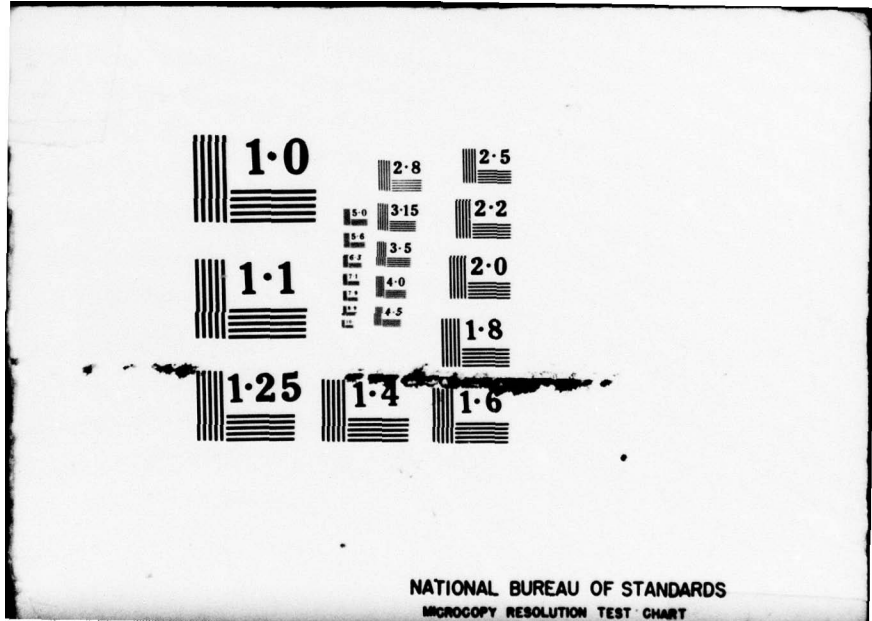



1. Basement of a Reinforced Concrete "Flat Plate" Office Building. This is a four-story reinforced-concrete flat plate structure with reinforced concrete walls, a basement and brick exterior. This building contains a personnel shelter which is located in specific portions of the ground floor (basement).

2. Basement of an Apartment Building. This is a 10-story steel framed building with masonry walls and a full basement. It was designed in accordance with the Chicago, Illinois Building Code. This study considered the sheltering potential of the basement in its as-built and upgraded states.

3. Emergency Operating Center, Livermore, California (Ref. 14). This is a one-story load-bearing reinforced-concrete masonry structure with a full basement. The basement, which was the subject of this study, has a reinforced concrete overhead slab and reinforced concrete peripheral walls. Interior basement walls consist of reinforced concrete masonry.

4. Hamilton Air Force Base, Building 424 (Ref. 14) This is a three-story reinforced-concrete frame building with reinforced concrete floor slab. The building has a basement which is partially above grade and has numerous windows. The basement of this building was the subject of the study.

5. Middlefield Parking Garage (Ref. 14). This structure consists of a two-story wood frame building with street level and underground parking areas. The underground garage which was the subject of this study, is fully buried and is located primarily below the street level parking area. Its roof system consists of one-way reinforced concrete joists supported by reinforced concrete girders spanning between circular reinforced concrete columns.

6. West Pavilion, Stanford University Hospital, Stanford, California (Ref. 14). The West Pavilion is one of several wings extending from the central core of the hospital. The building consists of three stories and a fully buried basement. The building has a reinforced concrete frame with exterior columns and interior reinforced concrete load-bearing walls. The floor system consists of transverse reinforced concrete tube slabs but with solid slabs along transverse column lines. The basement was the subject of the upgrading and evaluation effort.

Each shelter was evaluated in its as-built and upgraded conditions to the extent made possible by available data.

People survivability in a shelter is expressed in terms of probability of survival given a hazard environment. Expressions, probability of survival and percent survivors are synonymous and are used interchangeably. Survivors include injured and uninjured individuals. The hazard environment includes direct and indirect weapon effects relevant in producing casualties within the shelter. The hazard environment is identified (referenced) by the peak freefield overpressure at the location of the shelter. The process leading to the prediction of the probability of survival basically involves three steps, i.e.:

- (1) Definition of the weapon environment
- (2) Analysis of shelter response
- (3) Analysis of people response

For a given weapon size, height of burst and range, the loading that a shelter experiences depends on the type of terrain, shielding provided by neighboring structures and discontinuities that the shelter itself presents to the wave front. Depending on the size of the shelter and its structural system, the character of the loading may be modified as a consequence of shelter response. For example, the filling of the shelter by the blast may to some extent relieve (decrease) the loading on the roof. In such instances, i.e., when the shelter is breached by the blast winds but the structure does not collapse, rather intense flow regimes

are induced within. Personnel and objects located in the shelter will respond to the environment, in part, by being transported in some fashion (tumbled, slid, etc.) until the adverse environment is relieved or an impact with a wall or other object occurs. The nature and intensity of an impact, if one occurs, depends upon the many variables defining the explosion, the shelter, the object, and the location of the object and other objects within the shelter. The survivability of personnel to such impacts is a function of the nature and intensity of the impact (or perhaps impacts) and the complicated interactions of other adverse physiological effects such as blast overpressure exposure, i.e., direct blast.

The transient velocity field which exists within the shelter depends upon the geometry of the shelter and the size and location of the inlet opening or openings. Furthermore, the mass flow rate of air into and out of the interior shelter region or cavity is a significant factor. The latter effect is a function of the volume-to-area ratio of the shelter, where the pertinent area is the total inlet area. This effect also depends upon the free-air blast environment.

The structural response problem, although very complex since it involves dynamic nonlinear behavior, is nonetheless tractable. Sufficient amounts of analytical and experimental work have been done in the past decade to simplify and reduce such problems to manageable proportions by retaining only the principal modes of response. For example, in case of a deep, closed basement shelter with strong closures the structural response problem is generally reduced to the determination of the collapse load of the overhead slab. Procedures used in determining the collapse loads for various shelter components are described in detail for the first two shelters in Chapter 2. For the remaining four shelters use was made of collapse load data given in Ref. 14.

Injuries and fatalities can be produced by a variety of stimuli which may be present within the shelter environment during



a nuclear weapon attack. The casualty modes which can result from these stimuli are categorized as:

- Blunt Object Impact - This impact can occur locally such as on the head or distributively such as whole body impact. It can result from
  - (a) being struck by the collapse of a structural member of significant mass
  - (b) being translated against a massive object or structural element, or by
  - (c) being struck by flying debris (of nominal or low mass)

These stimuli produce locally high transient stresses within a portion of the body.

- Crushing - This casualty mode can occur due to the relatively slow collapse of massive structural elements. Such a stimulus produces moderately high stresses and loads on body components so that large deformations, rupture or breaks can occur.
- Penetrating Impact - The impact of relatively light-high velocity fragments, such as glass shreds can penetrate the soft body tissue and produce cuts and lacerations.
- Initial Radiation - Exposure to nuclear radiation can result in injury or fatality. Level of injury is proportional to dose rate. A part of this injury is repaired spontaneously at a rate proportional to the magnitude of injury, and an irreparable fraction is present which is proportional to the total accumulated dose. Death following an acute dose is due primarily to excessive reparable injury whereas life-shortening following chronic radiation is due to irreparable injury.
- Combined Effects - The undesirable stimuli which can occur within shelters will occur essentially simultaneously but at varying intensities, hence the occupants may be subject to more than one of the above casualty modes.

Thermal radiation was not considered important since people in shelters are shielded from this effect. Primary blast effects, i.e., effects due to fast rising overpressures were not considered because for the most part we are dealing with closed shelters and the significant range of overpressures is approximately 0 to 30 psi (0 to 206.84 kPa). Mean lethal overpressure (LD<sub>50</sub>) from

this effect is approximately 75 psi (517.11 kPa). Procedures used in evaluating the probability of survival are discussed in Ref. 29. The probabilities of survival in as-built and upgraded shelters as generated in this study are discussed next.

One obvious way to compare the results, i.e., the protection afforded by these basements is to first combine them on a single graph. However, since the survivability curves (see Figure 32,34, etc.) have different shapes, it is more useful to compare certain intermediate points such as the 10, 50 and the 90 percent probability of survival overpressure levels. These data were extracted and are summarized in Table 20. This table also identifies the six structures. Average values of survivability for the two classes of shelter, i.e., as-built and upgraded, were also computed and are included as the last entry in Table 20. A comparison is made in Figure 39 for individual shelters. Average values are compared in Figure 40.

Based on these results it is concluded that basements in high risk areas can be upgraded using expedient methods to achieve an MLOP of at least 26 psi (179.26 kPa) from a large yield weapon. Depending on the given ground rules for implementing expedient measures, a higher MLOP is possible. The level of protection achieved in any one case will be a strong function of several parameters such as type of structure being considered for upgrading, size of shelter, time, equipment, materials and labor available for implementation. For example, consider the Livermore EOC (Item 3 in Table 20). Its floor plan is shown in Figure 31. The survivability estimate is based on collapse overpressures for areas 1, 2 and 3 each of which has enough space for approximately eighty individuals. Should the number of individuals requiring shelter be less, say about 50 persons, then the MLOP can be increased. Use would be made of the smaller rooms (shown shaded) which are structurally stronger than the larger rooms. To take advantage of this higher resistance would require upgrading against initial nuclear radiation.

TABLE 20. PERCENT SURVIVORS AT INDICATED OVERPRESSURE LEVELS

Building Designation	90 Percent psi (kPa)	50 Percent psi (kPa)	10 Percent psi (kPa)
1. Office Building Basement (Flat Plate Overhead Floor)			
As Built	5.1 (35.16)	6.2 (42.75)	7.4 (51.02)
Upgraded	6.7 (46.19)	8.4 (57.92)	10.2 (70.33)
2. Apartment Building Basement			
As Built	1.0 ( 6.89)	1.5 (10.34)	2.5 (17.24)
Upgraded:	5.4 (37.23)	9.8 (67.57)	13.2 (91.01)
Scheme A	8.8 (60.67)	11.1 (76.53)	13.6 (93.77)
Scheme B	19.1 (131.69)	24.7 (170.30)	29.8 (205.46)
Scheme C	9.1 (62.74)	12.5 (86.18)	27.0 (186.16)
Scheme D			
3. Livermore EOC (Figure 31)			
As Built	15.8 (108.94)	26.1 (179.95)	30.7 (211.67)
Upgraded			
4. Hamilton AFB Building 424 (Figure 33)			
As Built	3.4 (23.44)	3.6 (24.82)	3.8 (26.20)
Upgraded	9.5 (65.50)	10.1 (69.64)	10.7 (73.77)
5. Middlefield Parking Garage (Figure 35)			
As Built	3.3 (22.75)	3.6 (24.82)	4.6 (31.72)
Upgraded:	6.5 (44.82)	7.2 (49.64)	9.2 (63.43)
Scheme 1	8.6 (59.29)	9.4 (64.81)	12.0 (82.74)
Scheme 2			
6. West Pavilion, SU Hospital Basement (Figure 37)			
As Built	10.0 (68.95)	10.7 (73.77)	11.5 (79.29)
Upgraded			
7. Average For All Basements			
As Built	3.2 (22.06)	3.7 (25.52)	4.6 (31.72)
Upgraded	9.9 (68.26)	13.3 (91.70)	17.4 (119.97)



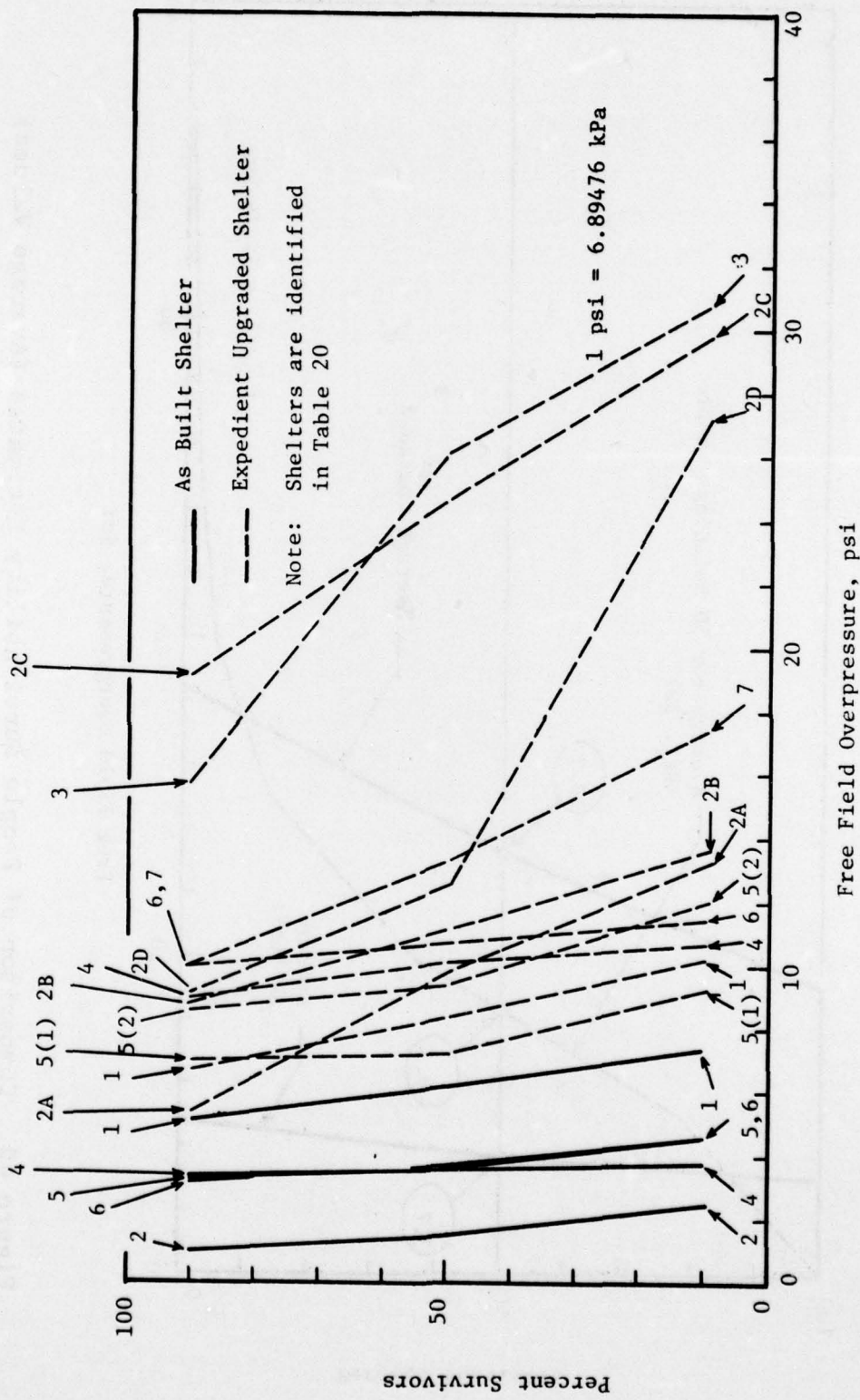

Figure 39. Comparison of People Survivability Estimates

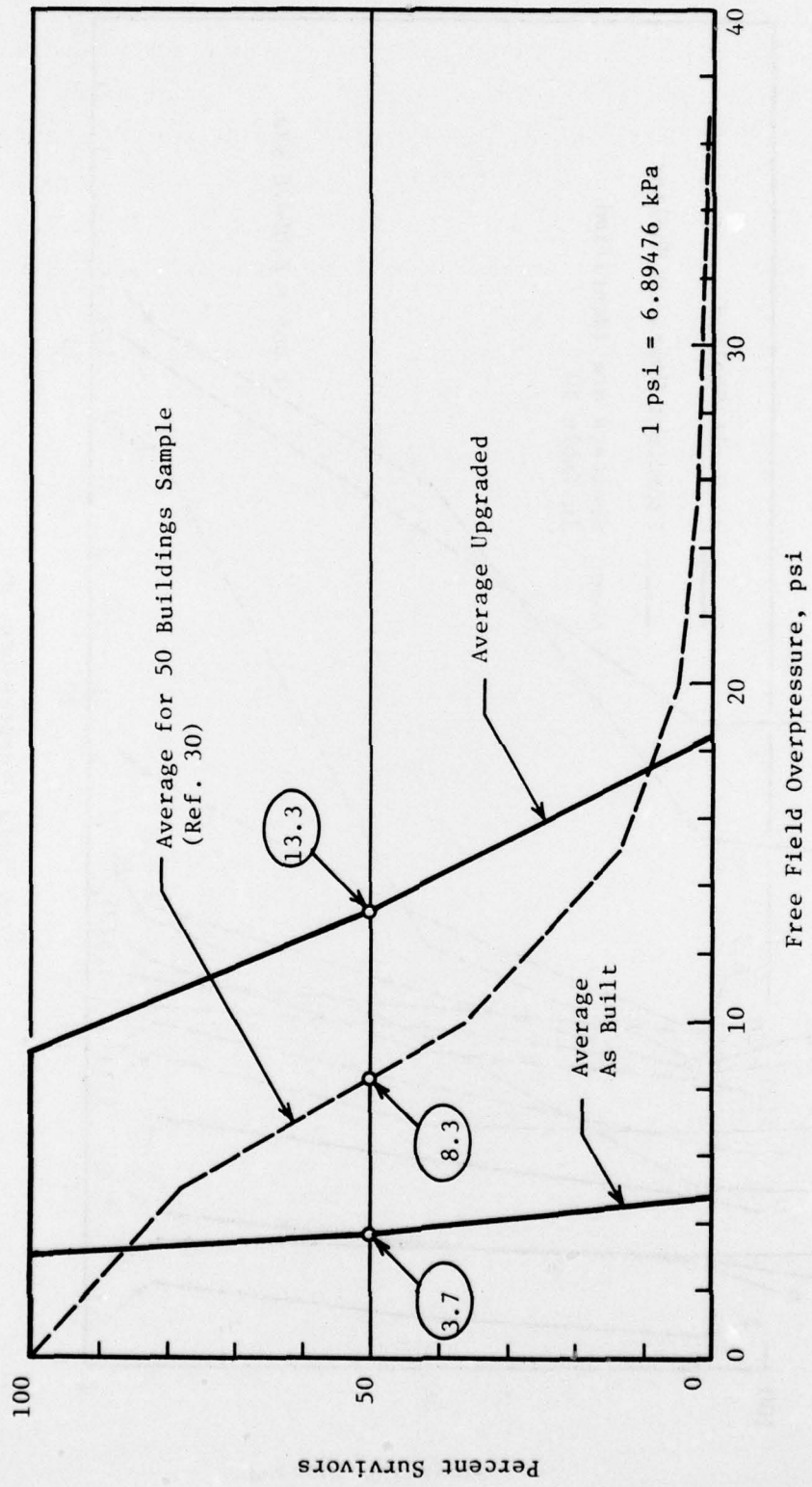

Figure 40. Comparison of People Survivability Estimates (Average Values)

The information contained in this report is capable of being used as initial criteria for projecting "people survivability" estimates for high risk population centers. To make such criteria more inclusive and applicable on a wider scale would require additional data of the type generated in this study. At the present time DCPA possesses a national, statistically valid sample of 219 buildings. This provides an excellent opportunity for generating the needed information. It is recommended that each of these buildings be evaluated to determine its survivability potential in both its as-built and expediently upgraded states.

It is important to note that information on the behavior of timber structures from initial yielding to ultimate collapse, when subjected to static and dynamic loads is very limited. This area should receive more attention since timber appears to be a very important material for expedient upgrading.



#### 4. REFERENCES

1. High Risk Areas for Civil Preparedness Nuclear Defense Planning Purposes, TR 82, DCPA, April 1975.
2. Memorandum for Deputy Assistant Director, R&E; Subject: Revision of Relative Blast Protection Codes, by George N. Sisson, Staff Director, Hazard Evaluation and Vulnerability Reduction Division.
3. DCPA Attack Environment Manual, Chapter 2 - What the Planner Needs to Know About Blast and Shock, Research Directorate, Defense Civil Preparedness Agency, June 1972.
4. Longinow, A., et al, People Survivability in a Direct Effects Environment and Related Topics, Contract DAHC20-63-C-0126, Work Unit 1614D, for DCPA, IIT Research Institute, May 1973.
5. Longinow, A., Survivability in a Direct Effects Environment (Analysis of 50 NFSS Buildings), for DCPA, Contract DAHC20-73-C-0227, IIT Research Institute, July 1974.
6. Edmunds, J. E., Experiments to Determine Debris Formation from Corrugated Steel and Brick Walls, for OCD, Contract DAHC20-69-C-0129, Work Unit 3313C, URS Research Company, January 1970.
7. Wilton, C. and Gabrielson, B., Shock Tunnel Tests of Wall Panels, for DCPA, Contract DAHC20-71-C-0223, URS Research Company, January 1972.
8. Keenan, W. A., Strength and Behavior of Restrained Reinforced Concrete Slabs Under Static and Dynamic Loadings, Technical Report R621, U.S. Naval Civil Engineering Laboratory, Port Hueneme, California, April 1969 (AD-688 421).
9. Denton, D. R., Dynamic Ultimate Strength Study of Simply Supported Two-Way Reinforced Concrete Slabs, Technical Report 1-789, U.S. Army Engineer Waterways Experiment Station (for the Office of Civil Defense), Vicksburg, Mississippi, July 1967 (AD-658-749).
10. Criswell, M. E., Design and Testing of a Blast-Resistant Reinforced Concrete Slab System, Technical Report N-72-10, U.S. Army Engineer Waterways Experiment Station (for Defense Civil Preparedness Agency), Vicksburg, Mississippi, November 1972.
11. Wiehle, C. K., All-Effects Shelter Survey System, Summary of Dynamic Analysis of 25 NFSS Buildings, Stanford Research Institute (for Defense Civil Preparedness Agency), Menlo Park, California, March 1973.

REFERENCES (continued)

12. Wiehle, C. K., Summary of the Dynamic Analysis of the Exterior Walls and Floor Systems of 50 NFSS Buildings, Contract DAHC20-73-C-0232, for DCPA, Stanford Research Institute, June 1974.
13. Tolman, D. F., et al, Estimated Characteristics of NFSS Inventory - Final Building Classification Report, Contract DAHC20-82-C-0277 for DCPA, Research Triangle Institute, November 27, 1972 (Revised).
14. Murphy, H. L., et al, Upgrading Basements for Combined Nuclear Weapons Effect: Expedient Options, Contract DCPA01-75-C-0302, Work Unit 1155C, Stanford Research Institute, May 1976.
15. Modification of Existing Buildings as Community Shelters, for Office of Civil Defense, Ammann & Whitney, Consulting Engineers, PG-80-3, Final Draft, January 1975.
16. Criswell, M. E., Strength and Behavior of Reinforced Concrete Slab-Column Connections Subjected to Static and Dynamic Loadings, for Office of Civil Defense under Work Order OCD-PS066-67, Work Unit 1127B, U.S. Army Engineer Waterways Experiment Station, Vicksburg, Mississippi, December 1970.
17. Design of Structures to Resist the Effects of Atomic Weapons, Strength of Materials and Structural Elements, Manual-Corps. of Engineers, U.S. Army EM1110-345-414, March 15, 1957.
18. Guralnick, S. A., et al, Laboratory Study of a 45 ft Square Flat Plate Structure, Portland Cement Association Bulletin 070, September 1963.
19. Full-Scale Testing of New York World's Fair Structures, Volume II, the Rathskeller Structure, National Academy of Sciences, 1969,
20. Biggs, J. M., Introduction to Structural Dynamics, Mc-Graw-Hill Book Company, 1964.
21. Huff, W. L., Collapse Strength of a Two-Way Reinforced Concrete Slab Contained Within a Steel Frame Structure, for DCPA, Contract DAHC20-68-W-0192, Work Unit 1127E, U.S. Army Waterways Experiment Station, Vicksburg, Mississippi, June 1975.
22. Newmark, N. M. and Haltiwanger, J. D., Air Force Design Manual; Principles and Practices for Design of Hardened Structures, Technical Documentary Report AFSWC-TDR-62-138, Air Force Special Weapons Center, Kirtland Air Force Base, New Mexico, December 1962.

REFERENCES (concluded)

23. Wiehle, C. K. and Bockholt, J. L., Dynamic Analysis of Reinforced Concrete Floor Systems, Contract DAHC20-71-C-0292, DCPA Work Unit 1154 I, for DCPA, Stanford Research Institute, May 1973.
24. Jensen, G. F., Summary of Existing Structures Evaluation Part III: Structural Steel Connections, Contract OCD-DAHC20-67-C-0136, OCD Work Unit 1126C for Office of Civil Defense, Stanford Research Institute, December 1969.
25. Building Code Requirements for Reinforced Concrete (ACI 318-63) American Concrete Institute, P.O. Box 4754, Redford Station, Detroit, Michigan 48219.
26. Design of Structures to Resist the Effects of Atomic Weapons, Strength of Materials and Structural Elements, EM1110-345-414 Manuals - Corps of Engineers - U.S. Army, 1957.
27. Manual of Steel Construction, American Institute of Steel Construction, Inc. Seventh Edition.
28. Private communication from C. Wiehle, SRI, January 19, 1978.
29. Longinow, A., et al, Personnel Survivability in Blast Wind Environment, Journal of the Engineering Mechanics Division, ASCE, EM2, 12853, April 1977.
30. Longinow, A., Survivability in a Direct Effects Environment (Analysis of 50 NFSS Buildings) for DCPA, Contract DAHC20-73-C-0227, IIT Research Institute, July 1974.



DISTRIBUTION LIST

One copy unless otherwise indicated

Defense Civil Preparedness Agency  
Research  
ATTN: Administrative Officer  
Washington, D.C. 20301 (50)

Mr. Carl K. Wiehle  
Stanford Research Institute  
333 Ravenswood Avenue  
Menlo Park, California 94025

Assistant Secretary of the Army (R&D)  
ATTN: Assistant for Research  
Washington, D.C. 20301

Director  
Ballistic Research Laboratory  
Attention: Document Library  
Aberdeen Proving Ground, Maryland 21005

Chief of Naval Research  
Washington, D.C. 20360

Civil Engineering Center/AF/PRECET  
Attention: Technical Library  
Wright-Patterson Air Force Base  
Dayton, Ohio 45433

Commander, Naval Supply Systems  
Command (0421G)  
Department of the Navy  
Washington, D.C. 20376

Director, Army Materials and  
Mechanics Research Center  
Attention: Technical Library  
Watertown, Massachusetts 02172

Commander  
Naval Facilities Engineering Command  
Research and Development (Code 0322C)  
Department of the Navy  
Washington, D.C. 20390

Commanding Officer  
U.S. Army Combat Developments Command  
Institute of Nuclear Studies  
Fort Bliss, Texas 79916

Defense Documentation Center  
Cameron Station  
Alexandria, Virginia 22314 (12)

Director, U.S. Army Engineer  
Waterways Experiment Station  
Attention: Document Library  
Post Office Box 631  
Vicksburg, Mississippi 39180

Civil Defense Research Project  
Oak Ridge National Laboratory  
ATTN: Librarian  
P.O. Box X  
Oak Ridge, Tennessee 37830

Mr. Donald A. Bettge  
Research and Engineering Directorate  
Defense Civil Preparedness Agency  
Washington, D.C. 20301

Dr. Lewis V. Spencer  
Radiation Theory Section 4.3  
National Bureau of Standards  
Washington, D.C. 20234

Mr. Anatole Longinow  
IIT Research Institute  
10 West 35th Street  
Chicago, Illinois 60616

Mr. Samuel Kramer, Chief  
Office of Federal Building Technology  
Center for Building Technology  
National Bureau of Standards  
Washington, D.C. 20234

Dr. Clarence R. Mehl  
Department 5230  
Sandia Corporation  
Box 5800, Sandia Base  
Albuquerque, New Mexico 87115

Director, Defense Nuclear Agency  
Attention: Mr. Jack R. Kelso  
Washington, D.C. 20305

Mr. Bert Greenglass  
Director, Office of Administration  
Program Planning and Control  
Department of Housing & Urban Development  
Washington, D.C. 20410

Los Alamos Scientific Laboratory  
Attention: Document Library  
Los Alamos, New Mexico 87544

Mr. George N. Sisson  
Research and Engineering Directorate  
Defense Civil Preparedness Agency  
Washington, D.C. 20301

Professor Robert Bailey  
Nuclear Engineering Department  
Duncan Annex  
Purdue University  
Lafayette, Indiana 47907

Mr. Luke J. Vortman  
Division 5412  
Sandia Corporation  
Box 5800, Sandia Base  
Albuquerque, New Mexico 87115

Director, Defense Nuclear Agency  
Attention: Technical Library  
Washington, D.C. 20305

Director  
Lovelace Foundation  
5200 Gibson Boulevard, S.E.  
Albuquerque, New Mexico 87108

Mr. Edward L. Hill  
Research Triangle Institute  
Post Office Box 12194  
Research Triangle Park, N.C. 27709

Mr. H. L. Murphy  
Stanford Research Institute  
333 Ravenswood Avenue  
Menlo Park, California 94025

Chief of Engineers  
Attention: ENGME-RD  
Department of the Army  
Washington, D.C. 20314

Commanding Officer  
U.S. Naval Civil Engineering Laboratory  
Attention: Document Library  
Port Hueneme, California 93041

AFWL/Civil Engineering Division  
Attention: Technical Library  
Kirtland Air Force Base  
Albuquerque, New Mexico 87117

Director, U.S. Army Engineer  
Waterways Experiment Station  
Attention: Nuclear Weapons Effects Branch  
Post Office Box 631  
Vicksburg, Mississippi 39180

Dikewood Industries, Inc.  
1009 Bradbury Drive, S.E.  
University Research Park  
Albuquerque, New Mexico 87106

Mr. William H. Van Horn  
URS Research Company  
155 Bovet Road  
San Mateo, California 94402

Dr. Rudolf J. Engelmann  
Energy Research and Development  
Administration (DBER)  
Washington, D.C. 20545

Emergency Technology Division  
Oak Ridge National Laboratory  
Attention: Librarian  
P.O. Box X  
Oak Ridge, Tennessee 37830



SURVIVABILITY IN CRISIS UPGRADED SHELTERS  
FINAL REPORT

UNCLASSIFIED  
IIT Research Institute  
101 pages; February 1978

Contract DCPA01-76-C-0321 Work Unit 1619B

ABSTRACT

This report contains the results of a study aimed at exploring the sheltering potential for people remaining in high risk areas when such areas are subjected to a nuclear weapon attack. Basements of six conventional buildings are evaluated when subjected to direct effects of a large yield nuclear weapon. On the basis of this evaluation probabilities of survival for shelter occupants are assigned. The six basements are subsequently upgraded using expedient measures and reevaluated subject to the same attack condition. Probabilities of survival for shelterees in conventional and upgraded basements are compared. It is concluded that basements in high risk areas can be upgraded using expedient methods to achieve a median lethal overpressure (MLOP) of at least 26 psi (179.26 kPa) from a large yield weapon. The level of protection achieved in any one case is a strong function of several parameters such as type of structure being considered for upgrading, size of shelter, time, equipment, materials, and labor available for implementation.

SURVIVABILITY IN CRISIS UPGRADED SHELTERS  
FINAL REPORT

UNCLASSIFIED  
IIT Research Institute  
101 pages; February 1978

Contract DCPA01-76-C-0321 Work Unit 1619B

ABSTRACT

This report contains the results of a study aimed at exploring the sheltering potential for people remaining in high risk areas when such areas are subjected to a nuclear weapon attack. Basements of six conventional buildings are evaluated when subjected to direct effects of a large yield nuclear weapon. On the basis of this evaluation probabilities of survival for shelter occupants are assigned. The six basements are subsequently upgraded using expedient measures and reevaluated subject to the same attack condition. Probabilities of survival for shelterees in conventional and upgraded basements are compared. It is concluded that basements in high risk areas can be upgraded using expedient methods to achieve a median lethal overpressure (MLOP) of at least 26 psi (179.26 kPa) from a large yield weapon. The level of protection achieved in any one case is a strong function of several parameters such as type of structure being considered for upgrading, size of shelter, time, equipment, materials, and labor available for implementation.

SURVIVABILITY IN CRISIS UPGRADED SHELTERS  
FINAL REPORT

UNCLASSIFIED  
IIT Research Institute  
101 pages; February 1978

Contract DCPA01-76-C-0321 Work Unit 1619B

ABSTRACT

This report contains the results of a study aimed at exploring the sheltering potential for people remaining in high risk areas when such areas are subjected to a nuclear weapon attack. Basements of six conventional buildings are evaluated when subjected to direct effects of a large yield nuclear weapon. On the basis of this evaluation probabilities of survival for shelter occupants are assigned. The six basements are subsequently upgraded using expedient measures and reevaluated subject to the same attack condition. Probabilities of survival for shelterees in conventional and upgraded basements are compared. It is concluded that basements in high risk areas can be upgraded using expedient methods to achieve a median lethal overpressure (MLOP) of at least 26 psi (179.26 kPa) from a large yield weapon. The level of protection achieved in any one case is a strong function of several parameters such as type of structure being considered for upgrading, size of shelter, time, equipment, materials, and labor available for implementation.

SURVIVABILITY IN CRISIS UPGRADED SHELTERS  
FINAL REPORT

UNCLASSIFIED  
IIT Research Institute  
101 pages; February 1978

Contract DCPA01-76-C-0321 Work Unit 1619B

ABSTRACT

This report contains the results of a study aimed at exploring the sheltering potential for people remaining in high risk areas when such areas are subjected to a nuclear weapon attack. Basements of six conventional buildings are evaluated when subjected to direct effects of a large yield nuclear weapon. On the basis of this evaluation probabilities of survival for shelter occupants are assigned. The six basements are subsequently upgraded using expedient measures and reevaluated subject to the same attack condition. Probabilities of survival for shelterees in conventional and upgraded basements are compared. It is concluded that basements in high risk areas can be upgraded using expedient methods to achieve a median lethal overpressure (MLOP) of at least 26 psi (179.26 kPa) from a large yield weapon. The level of protection achieved in any one case is a strong function of several parameters such as type of structure being considered for upgrading, size of shelter, time, equipment, materials, and labor available for implementation.