

FOR FURTHER TRAN *It's*

2

B.S.



AD A 055269

RADC-TR-78-92
Final Technical Report
April 1978

BROADBAND MODEM II

Bruce E. Gillingham
Robert C. Davis

Harris Corporation

Approved for public release; distribution unlimited.

DDC
RECEIVED
JUN 20 1978
RESERVED

CF E

ROME AIR DEVELOPMENT CENTER
Air Force Systems Command
Griffis Air Force Base, New York 13441

AD No. _____
JDC FILE COPY

78 06 15 044

This report has been reviewed by the RADC Information Office (OI) and is releasable to the National Technical Information Service (NTIS). At NTIS it will be releasable to the general public, including foreign nations.

RADC-TR-78-92 has been reviewed and is approved for publication.

APPROVED:

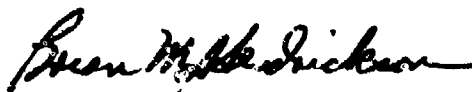

BRIAN M. HENDRICKSON
Project Engineer

APPROVED:



FRED I. DIAMOND
Technical Director
Communications and Control Division

FOR THE COMMANDER:

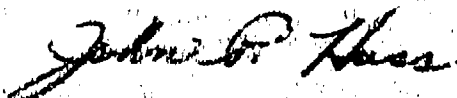

JOHN P. HUSS
Acting Chief, Plans Office

If your address has changed or if you wish to be removed from the RADC mailing list, or if the addressee is no longer employed by your organization, please notify RADC (DCCT) Griffiss AFB NY 13441. This will assist us in maintaining a current mailing list.

Do not return this copy. Retain or destroy.

UNCLASSIFIED

SECURITY CLASSIFICATION OF THIS PAGE (When Data Entered)

18 19 REPORT DOCUMENTATION PAGE		READ INSTRUCTIONS BEFORE COMPLETING FORM	
1. REPORT NUMBER RADC-TR-78-92 ✓	2. GOVT ACCESSION NO.	3. RECIPIENT'S CATALOG NUMBER	
4. TITLE (and Subtitle) BROADBAND MODEM II	5. TYPE OF REPORT & PERIOD COVERED Final Technical Report		
6. AUTHOR(s) Bruce E. Gillingham Robert C. Davis	7. PERFORMING ORG. REPORT NUMBER N/A		
8. PERFORMING ORGANIZATION NAME AND ADDRESS Harris Corporation/Electronic Systems Division P.O. Box 37 Melbourne FL 32901	9. CONTRACT OR GRANT NUMBER(s) F30602-76-C-0434		
10. PROGRAM ELEMENT, PROJECT, TASK AREA & WORK UNIT NUMBERS 62702F 45192110	11. CONTROLLING OFFICE NAME AND ADDRESS Rome Air Development Center (DCCT) Griffiss AFB NY 13441		
12. REPORT DATE Apr 1978	13. NUMBER OF PAGES 165 P.		
14. MONITORING AGENCY NAME & ADDRESS (if different from Controlling Office) Same	15. SECURITY CLASS. (of this report) UNCLASSIFIED		
16. DISTRIBUTION STATEMENT (of this Report) Approved for public release; distribution unlimited.			
17. DISTRIBUTION STATEMENT (of the abstract entered in Block 20, if different from Report) Same			
18. SUPPLEMENTARY NOTES RADC Project Engineer: Brian M. Hendrickson (DCCT)			
19. KEY WORDS (Continue on reverse side if necessary and identify by block number) Digital Microwave Modulation			
20. ABSTRACT (Continue on reverse side if necessary and identify by block number) The objective of this program was to optimize the techniques developed on the previous contract (Contract F30602-74-C-0263) from a cost and performance point of view and to implement an experimental modem suitable for extended test at RADC providing bandwidth efficient signalling for the line-of-sight microwave system. Specifically, spectral efficiency compliant with FCC Docket 19311 was required. A bit error rate of 5×10^{-9} at an E_b/N_0 of 22 dB for two bits/hertz of RF bandwidth operation or at an E_b/N_0 of 16 dB for one bit/hertz of RF bandwidth operation was desired. (Cont'd)			

16 total minus minutes

448972

dhc

UNCLASSIFIED

SECURITY CLASSIFICATION OF THIS PAGE(When Data Entered)

10 to the minus ninth power

20 (Cont'd)

An experimental modem was constructed and successfully tested, both in the laboratory and at RADC. All design requirements were met. Most notably, the performance goal of emission requirements as described in FCC Docket 19311 was met. The acquisition performance objective of 20 ms for a frequency offset of 20 kHz was met, as was the performance objective of 5×10^{-9} bit error rate at an E_b/N_0 of 16 dB for one bit/hertz operation. The design objective of a 5×10^{-9} bit error rate at an E_b/N_0 of 22 dB for two bits/hertz operation was exceeded in back-to-back tests and was within 0.6 dB for a group-delay compensated LC8D radio.

10 to the minus ninth power

ADDITION BY		
DTG	White Section	<input checked="" type="checkbox"/>
DDI	Self Section	<input type="checkbox"/>
UNANNOUNCED		<input type="checkbox"/>
JUSTIFICATION		
BY		
DISTRIBUTION/AVAILABILITY CODES		
Dist.	AVAIL. CODE/IF SPECIAL	
A		

UNCLASSIFIED

SECURITY CLASSIFICATION OF THIS PAGE(When Data Entered)

TABLE OF CONTENTS

<u>Paragraph</u>	<u>Title</u>	<u>Page</u>
1.0	INTRODUCTION	2
1.1	Objective	2
1.2	Approach	2
1.3	Results	2
1.4	Report Organization	3
2.0	ANALYTICAL RESULTS	6
2.1	Background	6
2.2	Summary of Broadband Modem II Study Phase	7
2.2.1	FCC 19311 Compliance	7
2.2.2	New Implementation Techniques	8
2.2.3	Improved Acquisition	8
2.2.4	Dual B/Hz Capability	8
2.3	Details of Study Phase	9
2.3.1	FCC Docket 19311 Spectrum Compliance	9
2.3.1.1	IF Filter/Limiter Approach	9
2.3.1.2	Waveguide Filter Approach	23
2.3.1.2.1	Filter Characteristics	23
2.3.1.2.2	Waveguide Filter Results	26
2.3.2	New Implementation Techniques	33
2.3.2.1	The Phase Detector Reference Problem	40
2.3.2.2	The Acquisition Problem	46
2.3.2.3	Dual B/Hz Capability	49
2.3.2.4	New Receiver IF Filter	50
3.0	HARDWARE DESCRIPTION	54
3.1	Modulator	54
3.2	Demodulator	57
3.3	FCC 19311 Waveguide Filter	60
4.0	TEST RESULTS	64
4.1	In-Plant Tests	64
4.1.1	Spectral Efficiency Results	64
4.1.2	BER Vs E_b/N_0	67
4.1.2.1	2 B/Hz Test Results	67
4.1.2.2	1 B/Hz Test Results	70
4.1.3	Acquisition Test Results	79
4.2	RAGC Tests	82
4.2.1	Spectral Efficiency Results	82
4.2.2	BER Versus E_b/N_0 Results	87
4.2.2.1	2 B/Hz Test Results	87
4.2.2.2	1 B/Hz Results	102

TABLE OF CONTENTS (Continued)

<u>Paragraph</u>	<u>Title</u>	<u>Page</u>
5.0	CONCLUSIONS.....	114

APPENDICES

A	FCC Docket 19311 Spectral Efficiency	115
B	Computer Simulation Program for Broadband Modem II	119
C	Test Plan	145

LIST OF ILLUSTRATIONS

<u>Figure</u>	<u>Title</u>	<u>Page</u>
1	1 B/Hz Spectrum Without Filtering	10
2	2 B/Hz Spectrum Without Filtering	10
3	Basic IF Filter Approach to FCC Docket 19311 Compliance ..	11
4	Eight-Pole, 18 MHz BW, 0.1 dB Tchebycheff Filtering	12
5	Four-Pole, 0.3X BR BW, Bessel Filtering	14
6	Eight-Pole, 0.33X BR BW, Bessel Filtering	15
7	Sinc Rolldown (+0.75 SR)	16
8	IF Filter Approach to FCC 19311	17
9	IF Approach Transmit Filter Characteristics	18
10	IF Approach 2 B/Hz Spectrum	20
11	IF Approach 1 B/Hz Spectrum	21
12	IF Filter Approach Performance	22
13	Nominal IF 19311 Approach Timing Sensitivity	24
14	Nominal IF 19311 Approach Threshold Spacing Sensitivity ..	25
15	Four-Pole Butterworth Waveguide Filter Attenuation Characteristics	27
16	Four-Pole Butterworth Waveguide Filter Delay Distortion Characteristics	28
17	Nominal Waveguide Baseline Transmit Attenuation	29
18	Nominal Waveguide Baseline Transmit Group Delay	30
19	Waveguide Approach 2 B/Hz Spectrum	31
20	Waveguide Approach 1 B/Hz Spectrum	32
21	Waveguide Approach Baseline Performance	34
22	Back-to-Back Waveguide Baseline (Without Filtering)	36
23	Waveguide Approach Detuning Sensitivity	37
24	Waveguide Approach Threshold Spacing Sensitivity	38
25	Nominal Waveguide Baseline Timing Sensitivity	39
26	Simplified Diagram of Breadboard Phase Detection Technique	40
27	Closed Loop Reference Derivation	42
28	Threshold Settings	43
29	A Representative Ideal Node and Surrounding Phase Bins with the Thresholds of Figure 28	44
30	Closed Loop Phase Reference Scheme Characteristics	45
31	Phase Detector - Demod for 4-ary CPFSK	46
32	Dual B/Hz Conversion	49
33	Receiver Filter Characteristics	51
34	Modulator Front Panel	54
35	Modulator Block Diagram	56
36	Demodulator Front Panel	57
37	Demodulator Block Diagram	59
38	Group Delay Distortion 4-Pole Butterworth Waveguide Filter	62
39	2 B/Hz Spectrum Without FCC 19311 Filter	65
40	2 B/Hz Spectrum With FCC 19311 Filter	65
41	1 B/Hz Spectrum Without FCC 19311 Filter	66
42	1 B/Hz Spectrum With FCC 19311 Filter	66

LIST OF ILLUSTRATIONS (Continued)

<u>Figure</u>	<u>Title</u>	<u>Page</u>
43	BER-2 B/Hz, Back-to-Back, Without Randomizer	68
44	BER-2 B/Hz, Back-to-Back, With Randomizer	
	Channel A - 26.82 Mb/s	69
45	BER-2 B/Hz, Back-to-Back, With Randomizer	
	Channel A - 13.41 Mb/s	71
46	BER-2 B/Hz, Back-to-Back, With Randomizer	
	Channel B - 13.41 Mb/s	72
47	BER-2 B/Hz, Back-to-Back, Test Mode	73
48	BER-2 B/Hz, With FCC 19311 Waveguide Filter, Without Randomizer	74
49	BER-1 B/Hz, Back-to-Back, Without Randomizer	75
50	BER-1 B/Hz, Back-to-Back, With Randomizer	76
51	BER-1 B/Hz, Back-to-Back, Test Mode	77
52	BER-1 B/Hz, With FCC 19311 Filter, Without Randomizer	78
53	2 B/Hz Acquisition, IF Offset +20 kHz	80
54	2 B/Hz Acquisition, IF Offset -20 kHz	80
55	1 B/Hz Acquisition, IF Offset +20 kHz	81
56	1 B/Hz Acquisition, IF Offset -20 kHz	81
57	2 B/Hz Spectrum Measured at LC8D Radio Transmitter Output (8 GHz) Without FCC 19311 Waveguide Filter	83
58	1 B/Hz Spectrum Measured at LC8D Radio Transmitter Output (8 GHz) Without FCC 19311 Waveguide Filter	84
59	2 B/Hz Spectrum Measured at LC8D Radio Transmitter Output (8 GHz) With FCC 19311 Waveguide Filter	85
60	1 B/Hz Spectrum Measured at LC8D Radio Transmitter Output (8 GHz) With FCC 19311 Waveguide Filter	86
61	2 B/Hz Spectrum Measured at LC8D Radio Receiver IF With FCC 19311 Filter	88
62	1 B/Hz Spectrum Measured at LC8D Radio Receiver IF With FCC 19311 Filter	89
63	BER-2 B/Hz, Back-to-Back, With Randomizer	90
64	BER-2 B/Hz, LC8D Radio, Without FCC 19311 Waveguide Filter, With Randomizer	92
65	BER-2 B/Hz, LC8D Radio, With FCC 19311 Waveguide Filter and Randomizer	93
66	BER-2 B/Hz, LC8D Radio, With FCC 19311 Waveguide Filter, Without Randomizer	94
67	BER-2 B/Hz, LC8D Radio, With FCC 19311 Waveguide Filter, AGC Amplifier and Randomizer	95
68	BER-2 B/Hz, LC8D Radio, With FCC 19311 Waveguide Filter and AGC Amplifier, Without Randomizer	96
69	Amplitude Response and Group Delay of LC8D With FCC 19311 Filter, Without Equalization	98
70	Amplitude Response and Group Delay of LC8D With FCC 19311 Filter, With $4/25$ ns/MHz ² Parabolic Group Delay Equalization	98

LIST OF ILLUSTRATIONS (Continued)

<u>Figure</u>	<u>Title</u>	<u>Page</u>
71	BER-2 B/Hz, LC8D Radio, With FCC 19311 Waveguide Filter, AGC Amplifier, Randomizer, and $4/25 \text{ ns/MHz}^2$ Parabolic Equalization	99
72	BER-2 B/Hz, LC8D Radio, With FCC 19311 Waveguide Filter, AGC Amplifier, Randomizer, and Radio Noise	100
73	BER-2 B/Hz, LC8D Radio, With FCC 19311 Waveguide Filter, AGC Amplifier, Randomizer, $4/25 \text{ ns/MHz}^2$ Parabolic Equalization, and Radio Noise	101
74	BER-1 B/Hz, Back-To-Back, With Randomizer	103
75	BER-1 B/Hz, LC8D Radio, Without FCC 19311 Waveguide Filter, With Randomizer	104
76	BER-1 B/Hz, LC8D Radio, With FCC 19311 Waveguide Filter and Randomizer	105
77	BER-1 B/Hz, LC8D Radio, With FCC 19311 Waveguide Filter, Without Randomizer	106
78	BER-1 B/Hz, LC8D Radio, With FCC 19311 Waveguide Filter, AGC Amplifier, and Randomizer	107
79	BER-1 B/Hz, LC8D Radio, With FCC 19311 Waveguide Filter, and AGC Amplifier, Without Randomizer	108
80	BER-1 B/Hz, LC8D Radio, With FCC 19311 Waveguide Filter, AGC Amplifier, Randomizer, and $4/25 \text{ ns/MHz}^2$ Parabolic Equalization	109
81	BER-1 B/Hz, LC8D Radio, With FCC 19311 Waveguide Filter, AGC Amplifier, Randomizer, and Radio Noise	111
82	BER-1 B/Hz, LC8D Radio, With FCC 19311 Waveguide Filter, AGC Amplifier, Randomizer, $4/25 \text{ ns/MHz}^2$ Parabolic Equalization and Radio Noise	112
A-1	Comparison of Mod Index 0.25 4-ary FSK Spectrum With 19311 Requirement	117
A-2	Comparison of Mod Index 0.125 4-ary FSK Spectrum With 19311 Requirement	117
B-1	Situation That Computer Program Can Handle	120
C-1	Modulator Conceptual Block Diagram	147
C-2	Demodulator Conceptual Block Diagram	148
C-3	In-Plant Test Configuration	150
C-4	Up/Downconverter for In-Plant Waveguide Filter Tests	150
C-5	Acquisition Test Set Configuration	152
C-6	RADC Test Configuration	153

LIST OF TABLES

<u>Table</u>	<u>Title</u>	<u>Page</u>
1	Nominal Baseline Conditions for IF Approach	23
2	Nominal Baseline Conditions for Waveguide Filter Approach	35
3	Effect of Changing Acquisition Specification on the Single Loop BW Reference Scheme	48

EVALUATION

The attainment of bandwidth efficient digital communications over line-of-sight (LOS) has been limited by non-linear power amplifiers. The optimum signal structures for bandwidth efficiency are those wherein the information is stored in the signal amplitude, i.e., amplitude shift keying (ASK). In order to perform well, ASK-type signal structures require linear operation. This forces one to attempt to linearize the amplifier (usually a traveling wave tube) by backing it off; however, this results in lower power outputs and thus lower system gain which can reduce system availability.

An alternative approach is to use techniques which store the information in phase or frequency (PSK or FSK) and are not effected by non linearities; however these signal structures are less bandwidth efficient than linearly driven structures. The emphasis in this program, and the study/breadboard effort which preceded it, was in optimizing the phase trajectory to minimize spectral occupancy but yet optimizing performance. The technique selected and implemented as optimum, was 4 level phase continuous FSK. It was determined during the course of the program that FCC 19311 could not be met exclusively with waveform design without compromising bit error rate (BER) performance. Consequently an all waveguide filter was fabricated to reduce the spectral sidelobes to fit the FCC 19311 mask. The use of RF filters for spectral containment is an accepted technique; however, RF filtering cannot be used exclusively because of the excessive group delay and amplitude distortion introduced, necessitating the use of a complicated equalizer at the receiver. The best results are achieved by a combination of waveform design and RF filtering.

As a result of this combination of waveform design and RF filter design the experimental model developed on this program delivered 2 bits per Hz transmission and achieved a BER of 5×10^{-9} at an E_b/N_0 of 22.6dB. System gain is not compromised because amplifier non-linearities are not a factor. Performance is very competitive with presently reported linear or quasi-linear techniques which cannot provide as high a system gain because of the TWT backoff required to obtain linear operation.

BRIAN M. HENDRICKSON
Project Engineer

SECTION 1.0
INTRODUCTION

1.0 INTRODUCTION

1.1 Objective

The objective of this program was to optimize the techniques developed on the previous contract (F30602-74-C-0263) from a cost and performance point of view, and to implement an experimental modem providing bandwidth efficient signalling for line-of-sight microwave systems. Specifically, spectral efficiency compliant with FCC Docket 19311 was required. A bit error rate of 5×10^{-9} at an E_b/N_0 of 22 dB for 2 bits/sec/Hz (B/Hz) of RF bandwidth operation or at an E_b/N_0 of 16 dB for 1 B/Hz of RF bandwidth operation was desired. These characteristics, provided in conjunction with hard-limiting radio sets, allow efficient conversion of analog FDM-FM line-of-sight microwave systems to digital operation by replacement of the modulation elements.

1.2 Approach

The program consisted of two main phases. During the first phase, an analytical study was undertaken to expand upon techniques developed on the previous program. It was desired that the experimental modem provide significantly improved performance over the previously constructed breadboard as well as additional operational features. In the second phase, the experimental modem was constructed and tested both in the laboratory and on an actual microwave radio.

1.3 Results

The experimental modem was successfully tested both in the laboratory and the Rome Air Development Center (RADC). All design requirements were met. Most notably, the performance goal of emission requirements as described in FCC Docket 19311 was met with some margin. The acquisition performance objective of 20 ms for an IF frequency offset of 20 kHz was met, as was the performance objective of 5×10^{-9} bit error rate at an E_b/N_0 of 16 dB for 1 B/Hz operation. The design objective of a 5×10^{-9} bit error rate at an E_b/N_0 of 22 dB for 2 B/Hz

operation was exceeded in back-to-back tests and was within 0.6 dB for a group-delay compensated LC8D radio.

A significant accomplishment of this program was developing an experimental modem which, unlike the previous breadboard, is simple to operate and stable in performance. All tests at RADC was performed with the modem as received from shipment without any realignment. Performance degradation from that obtained in the laboratory was negligible.

1.4 Report Organization

The results of the analytical effort are presented in Section 2.0. The design and construction of the modem are discussed in Section 3.0. In Section 4.0 the test program and results are presented. The conclusions are presented are in Section 5.0.

SECTION 2.0
ANALYTICAL RESULTS

2.0 ANALYTICAL RESULTS

2.1 Background

This section describes the analytical effort on this program. On a prior contract (Contract F30602-74-C-0263) for Rome Air Development Center (RADC), a study was performed to choose a bandwidth efficient signalling scheme for the microwave line-of-sight channel. Design objectives on the prior contract included 99 percent spectral occupancy of one-half bit rate and 20 dB E_b/N_0 for 10^{-7} error rate. Primarily because of the microwave radio saturated TWT amplifiers, the signal design effort on the prior contract was restricted to constant envelope signalling schemes. This type signalling avoids problems caused by AM/PM conversion characteristics of the TWT's.

The conclusion on the prior contract was that 4-ary continuous phase FSK with frequency spacing equal to one-eighth the symbol rate represented the best performance/complexity versus spectral occupancy trade-off. On the prior effort, a unique technique was developed for demodulating the 4-ary FSK signal such that near-optimum performance was obtained. The technique was the subject of an "abstract of new technology" on the prior contract.

After the prior study effort, a breadboard model of the modem was constructed and the feasibility of the scheme was verified through both laboratory measurements and actual microwave link tests at RADC. The results are included in the final report (RADC-TR-76-117) to RADC.

As with most breadboard efforts, there were implementation features of the modem that were operationally inconvenient, such as acquisition of the phase detection reference loop. In addition several difficult and critical timing adjustments were required to obtain predicted performance. One of the primary motivations of the present contract was to eliminate the difficulties and shortcomings associated with the original breadboard. A stated design objective for the present effort was to acquire 20 kHz frequency offset in 20 ms at an E_b/N_0 corresponding to a 10^{-7} bit error rate.

In the prior contract the spectral criterion imposed was 99 percent spectral occupancy in one-half bit rate RF bandwidth. For the present effort, the spectral criterion imposed is that of meeting the FCC Docket 19311 (See Appendix A) spectral mask for an authorized bandwidth of one-half bit rate. This criterion places a more stringent requirement on the side lobes of the transmitted spectrum than did the original 99 percent spectral occupancy criterion.

Another goal of the present study was to develop a technique for providing 1 B/Hz operation (again under FCC docket 19311 criterion) as well as 2 B/Hz operation.

New implementation techniques were to be investigated with an eye to reducing the cost and complexity of the original breadboard. Finally, an experimental modem was to be implemented incorporating the results of the study phase of the present effort. This modem was then to be used for tests at RADC on their microwave test facility.

2.2 Summary of Broadband Modem II Study Phase

This paragraph presents a brief summary of the major results and conclusions of the effort. A more detailed discussion follows in Paragraph 2.5.

2.2.1 FCC 19311 Compliance

Both 70 MHz IF Filter/Limiter and 8 GHz microwave waveguide filter approaches were investigated. The best IF filter/limiter combination provided theoretical E_b/N_0 of 23.1 dB for a 5×10^{-9} bit error rate. The waveguide filter approach yielded theoretical E_b/N_0 of 20 dB for a 5×10^{-9} bit error rate. The waveguide filter approach was adopted as the baseline. Discussions with waveguide filter manufacturers indicated that less than 1 dB of insertion loss could be achieved. Additionally, INVAR construction of the filter yielded tolerable detuning of less than ± 450 kHz over a 0° to 50° C temperature range. The waveguide filter selected is nominally 4-pole Butterworth with a 3 dB bandwidth of 16 MHz.

2.2.2 New Implementation Techniques

The "closed-loop reference derivation" technique was adopted for this modem. The basic idea is to use the known phase nodes of 4-ary FSK with which to compare the measured phase from the Quadrature Phase Detector (QPD) to determine the phase error to closest node. This error signal is filtered by a loop filter in the same manner as a normal PLL and the resultant signal used to drive the VCO which provides the QPD reference. This "closed-loop" reference derivation technique bears a close resemblance to COSTAS-type loops widely used to establish coherent references. This eliminated critical reference phasing problems in the original breadboard as well as simplified the modem reference generation. Sample and hold circuits were included in the phase detectors to alleviate the critical symbol timing problems encountered in the previous breadboard. The receiver IF filter was changed to 4-pole Butterworth with phase compensation, rather than the 4-pole Bessel used in the previous Breadboard.

2.2.3 Improved Acquisition

Computer simulations indicated a dual reference derivation loop bandwidth approach was required to acquire 80 kHz of frequency offset in 1 ms. A single loop bandwidth approach will acquire 20 kHz of offset in 20 ms or 80 kHz offset in 320 ms. The goal was modified in consultation with RADC to 20 ms acquisition with 20 kHz frequency offset. Therefore, a single loop bandwidth approach was adopted to simplify the hardware on the experimental modem.

2.2.4 Dual B/Hz Capability

A technique was developed to provide 1 B/Hz capability in addition to 2 B/Hz capability. Both capabilities are designed to operate in an authorized bandwidth of 14 MHz. Both modes meet corresponding FCC 19311 spectral masks using a common waveguide filter. The 1 B/Hz technique involves a relatively simple conversion technique at the demodulator IF input that exploits maximum equipment commonality between the two spectral capabilities.

2.3 Details of Study Phase

This section outlines the study effort undertaken to achieve the objectives of the Statement of Work for this program.

2.3.1 FCC Docket 19311 Spectrum Compliance

At the outset of this contract it was felt that one of the most challenging theoretical problems was to achieve compliance with FCC Docket 19311 spectral requirements. Figures 1 and 2 show the spectra for 1 B/Hz and 2 B/Hz modes for unfiltered 4-ary FSK relative to the appropriate spectral masks from FCC 19311. The 1 B/Hz mode uses frequency spacing of 1/4 symbol rate (mod-index 1/4) and the 2 B/Hz mode uses frequency spacing of 1/8 symbol rate (mod-index 1/8). As shown, the 1 B/Hz mode violates the mask as much as 15 dB and the 2 B/Hz mode violates the mask as much as 18 dB in the side lobes.

Two primary approaches for obtaining FCC 19311 compliance were pursued during the study phase. These were: (1) 70 MHz IF filtering followed by hard limiting at the modulator before interfacing with the 70 MHz IF radio input, and (2) 8 GHz microwave waveguide filtering. These approaches are described below.

2.3.1.1 IF Filter/Limiter Approach

The IF filter approach is shown in block diagram form in Figure 3. Originally, it appeared that the IF approach would be preferred over the waveguide filter approach from the standpoint of operational considerations. The IF filters could be readily changed or replaced to meet varying bit rate requirements in an operational system. It was decided that consideration of waveguide filtering should be deferred until an IF filtering approach could be thoroughly evaluated.

Consequently, an effort was undertaken to analytically characterize the IF filter approach. Important elements of this characterization were: (1) computation of radiated power spectrum, and (2) computation of modem performance (BER versus E_b/N_0). A FORTRAN computer program was written to perform these computations. The chief analytical tool used in

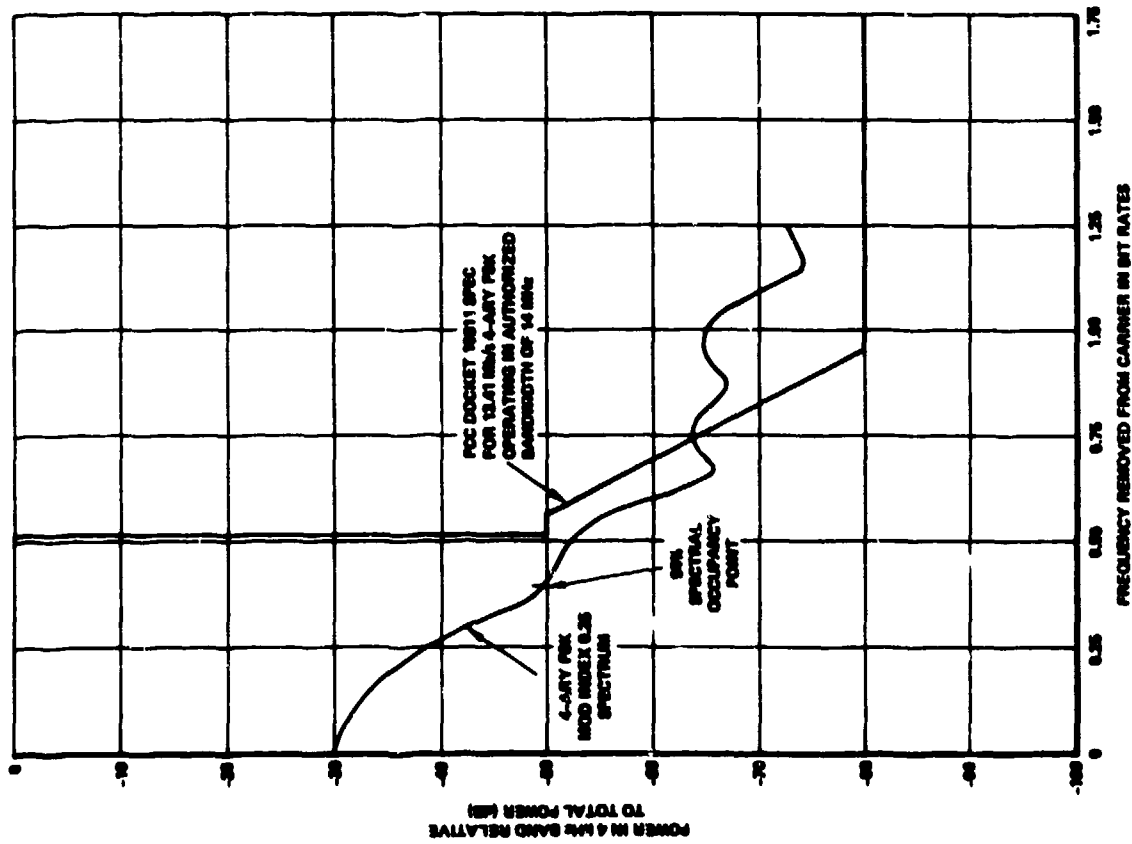

Figure 1. 1 B/Hz Spectrum Without Filtering

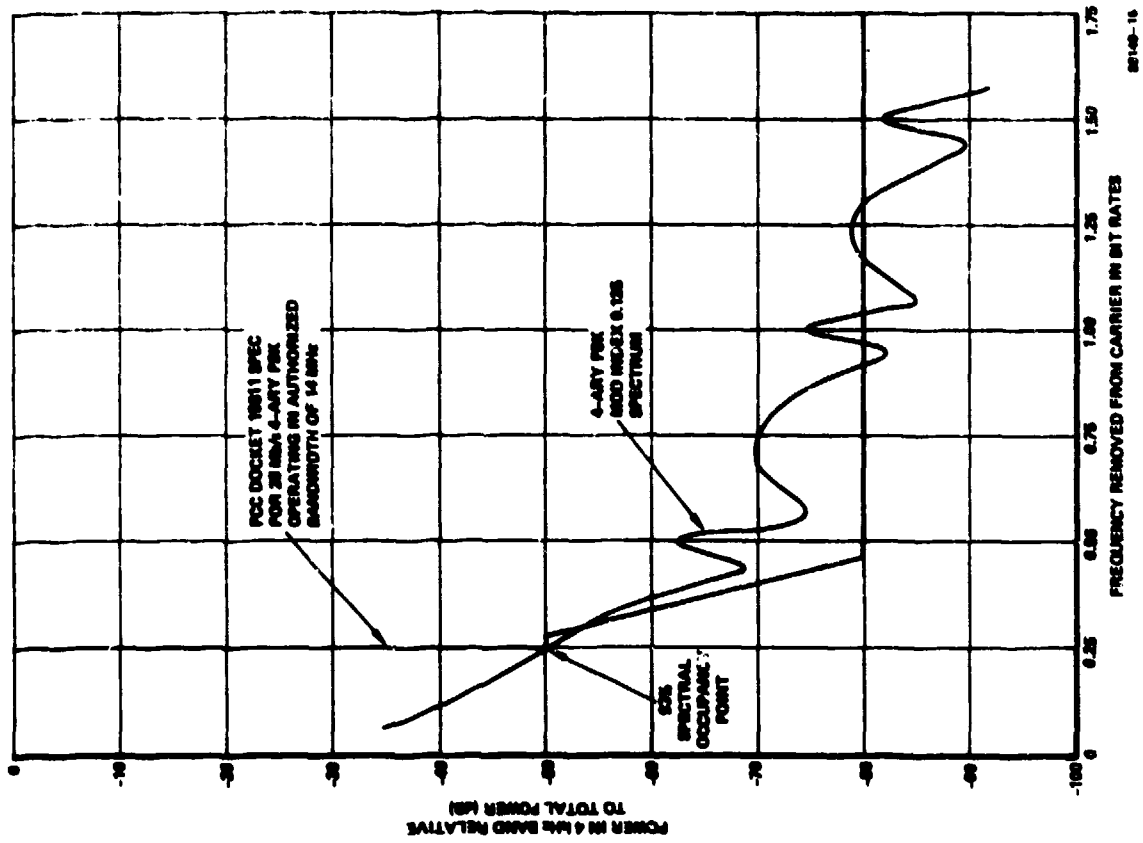

Figure 2. 2 B/Hz Spectrum Without Filtering

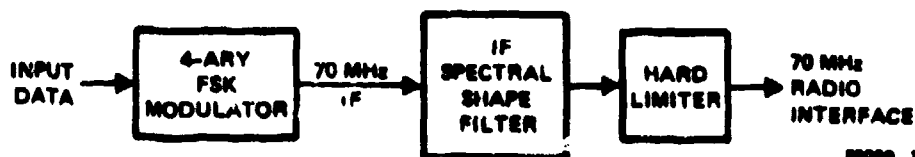

Figure 3. Basic IF Filter Approach to FCC Docket 19311 Compliance

this program is a Fast Fourier Transform (FFT) routine. Spectra are obtained by averaging FFT's over many random symbol sequences. Time-domain parameters necessary for computing modem performance are also computed with the FFT. The time-domain quantities of most importance in determining modem performance are phase measurements of the filtered (hence distorted) received FSK waveform. The computer program also includes a portion which computes the average symbol error rate given the distorted phase measurements. The computer program is described in more detail and a listing is presented in Appendix B. This program was used to produce the results given below for both the IF and waveguide filter approaches to FCC 19311 compliance.

At the outset of the IF filter search a good analytical or intuitive grasp of the effects of the filter/limit combination was not available. The approach taken therefore was to try various combinations of what seemed to be reasonable type filters and calculate spectra after the limiter with the computer program. During this extensive iterative process some intuitive understanding of necessary requirements on the filter for meeting FCC 19311 began to emerge.

First and foremost among the characteristics of the filter/limit combination is the limiter's restoration (to a large degree) of the prefilter side lobe levels for many filters. Figure 4 is a case in point. The spectrum is plotted versus $32 \left| \frac{f-f_c}{T_s} \right|$ where f = frequency, f_c = center frequency, and T_s is the 4-ary FSK symbol time. The quantity $\left| \frac{f-f_c}{T_s} \right|$ is thus the number of symbol rates removed from center frequency. Here the filter is an 8-pole 0.1 dB ripple Tchebycheff design with the 3 dB point at 20 on the horizontal scale. The major offending side lobe prior to filtering occurs at 32 on the horizontal scale and has level of -62 dB. The Tchebycheff filter has an attenuation of 55 dB at this side lobe frequency thereby placing the prelimiter side lobe level at -117 dB. As shown, after limiting, the side lobe is restored to the -69 dB level for a

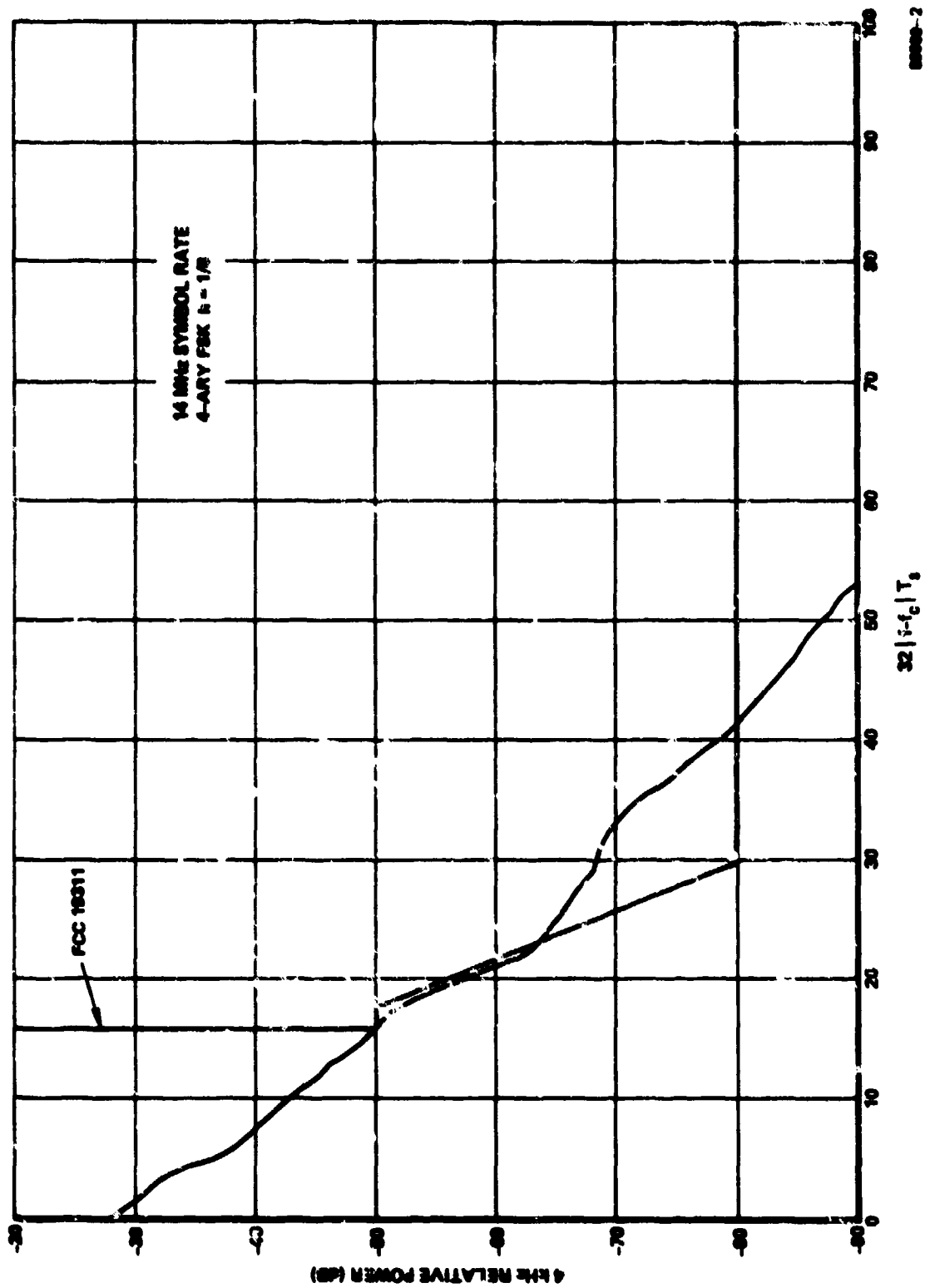

Figure 4. Eight-Pole, 18-MHz BW, 0.1 dB Tchebycheff Filtering

net gain of only 7 dB over the prefilter level. This ineffectiveness at reducing the major side lobe was found to hold for all filters that insignificantly filtered the main lobe of the spectrum.

The reason for this is clear in retrospect based on the fact that the main lobe inside the authorized bandwidth contains 99 percent of the signal power. Filtering that leaves this lobe relatively untouched does not significantly distort or change the phase modulation of the original waveform. Since phase modulation is the only filtered signal characteristic that survives through the hard-limiter, it is then reasonable that the spectral side lobes would be restored to a large extent. Since such filtering affects only 1 percent of the total energy, it follows that only low level side lobes would be significantly reduced.

After observing these effects and in response to the argument above, it was concluded that only IF filters which filter the main lobe significantly had any hope of resulting in FCC 19311 compliance. The necessity for such bandwidth restrictive filters of course implies performance degradation due to additional intersymbol interference.

From previous computer simulations evaluating the effect of filters on FSK signals, it was felt that small group delay distortion would be of paramount importance in holding performance degradation to acceptable levels. At this point in the IF filter investigation, various perfectly phase compensated filters as well as Bessel filters (which have very low group delay distortion characteristics) were analyzed. Figures 5 and 6 show the spectra obtainable with 4-pole and 8-pole Bessel filters respectively when followed by hard limiting. The 4-pole filter 3 dB bandwidth is 0.3 times bit rate while for the 8-pole filter, a 0.33 times bit rate bandwidth is used. Rough calculations of performance indicated approximately 2 dB loss in performance relative to the previous breadboard modem.

Figure 7 shows the spectrum obtained with an IF filter with sinc function ($\text{sinc}(x) = \sin(x)/X$) rolloff out to the first null at ± 0.75 symbol rate. The -3 dB bandwidth of this filter is 0.331 times bit rate. Rough calculations indicated a little less than 2 dB degradation with this filter relative to the previous breadboard.

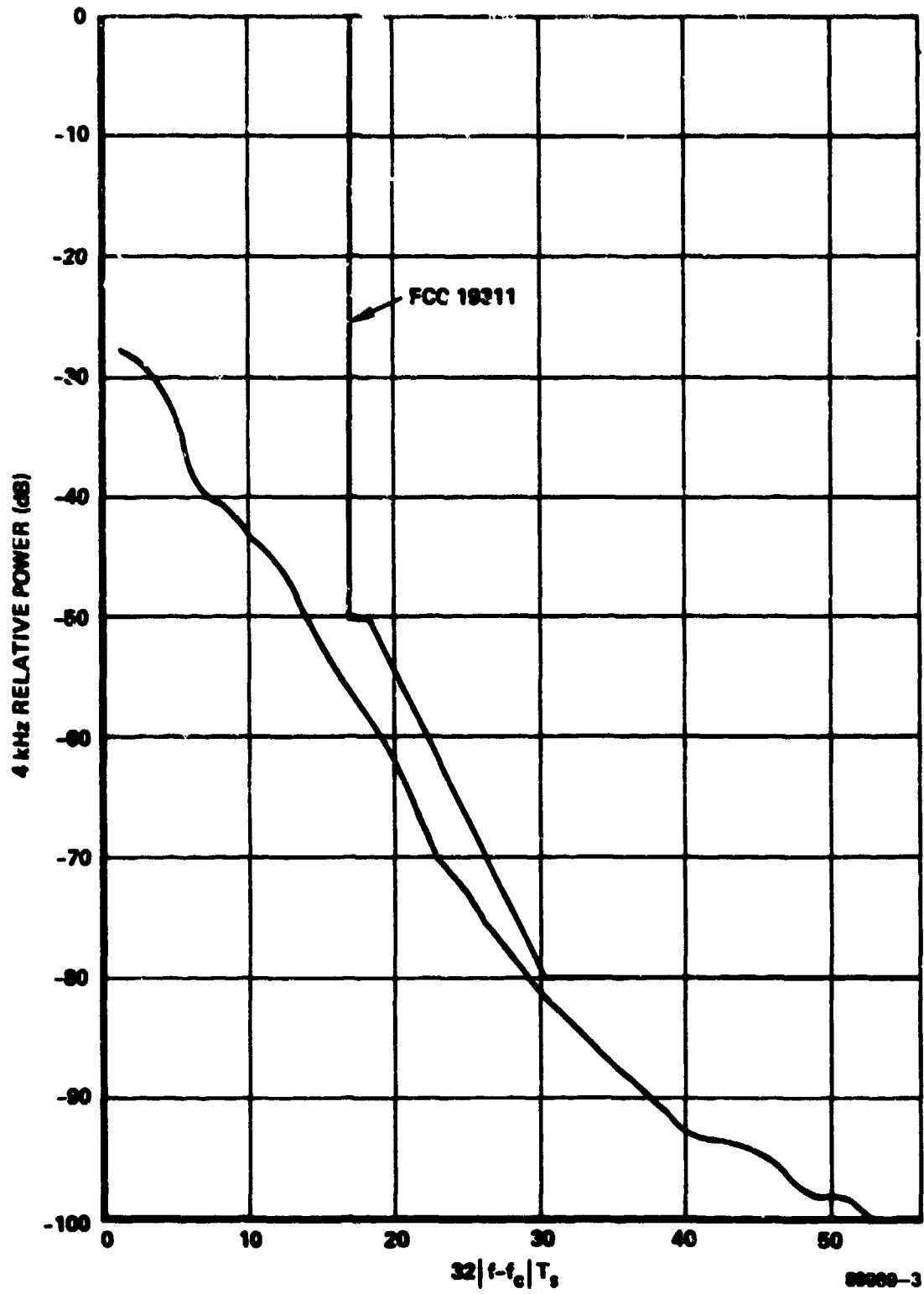

Figure 5. Four-Pole, 0.3X BR BW, Bessel Filtering

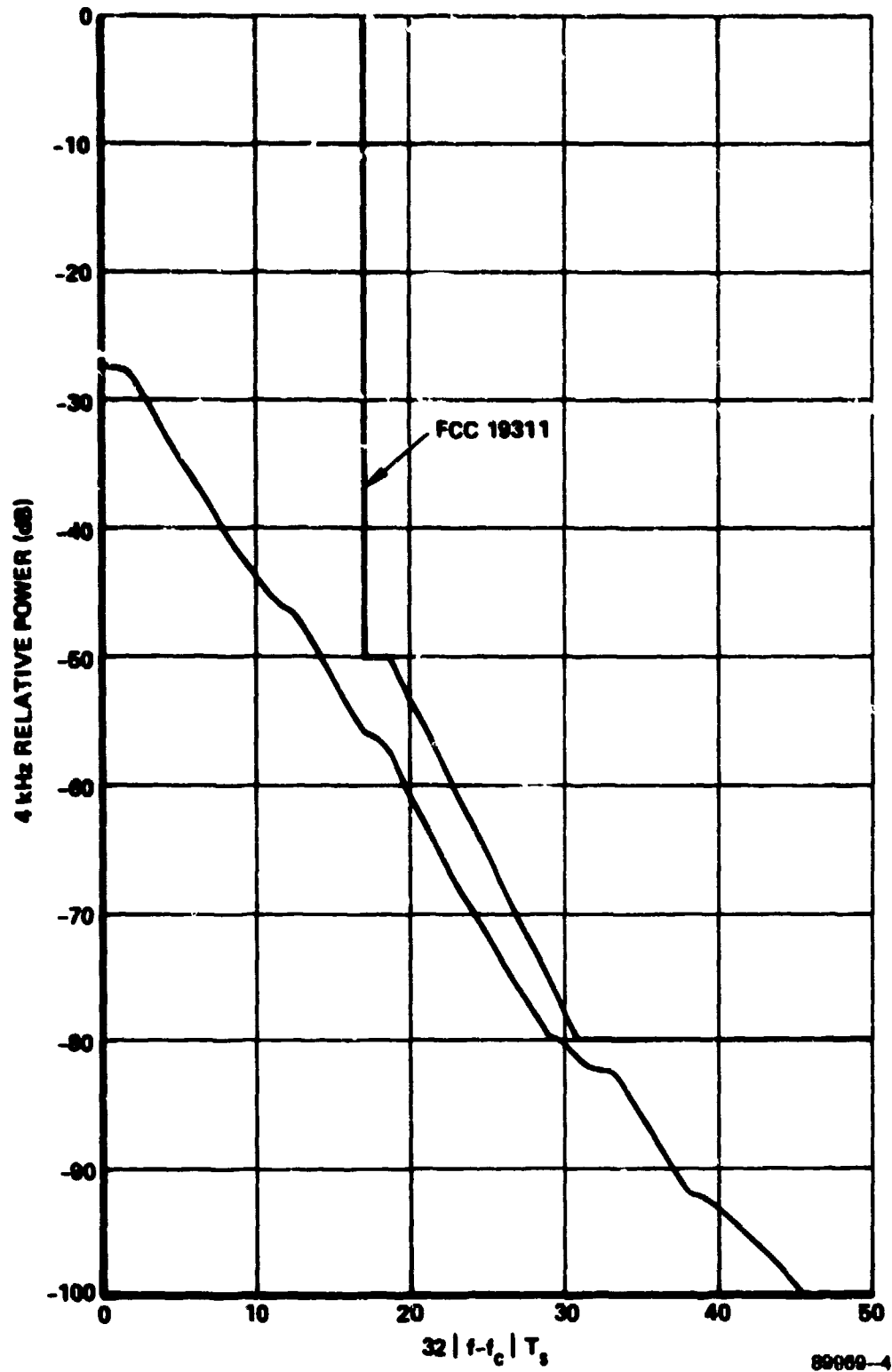

Figure 6. Eight-Pole, 0.33X BR BW, Bessel Filtering

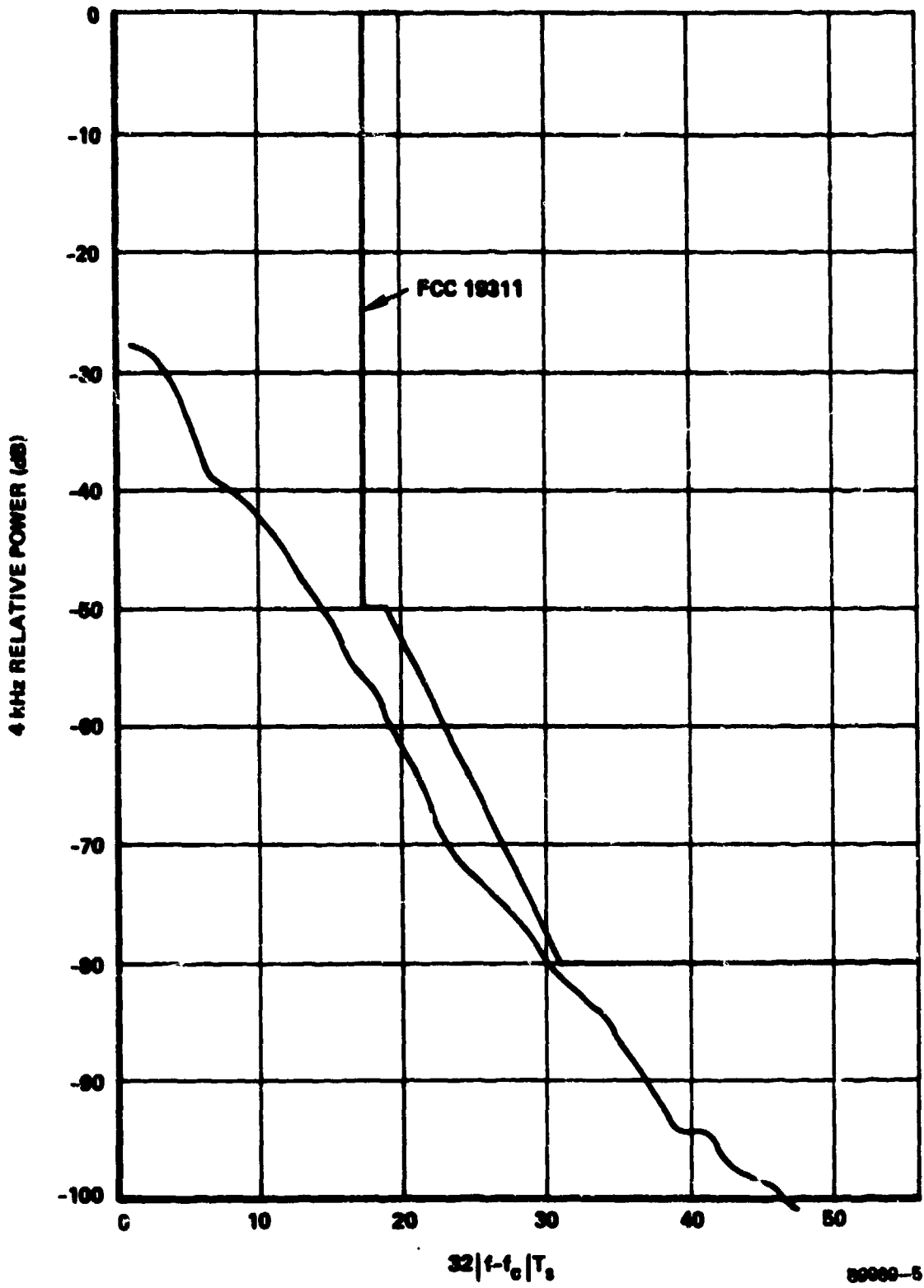

Figure 7. Sinc Rolldown (± 0.75 SR)

From these results, it was concluded that a 3 dB IF bandwidth of between 0.3 to 0.4 times bit rate would be required to meet FCC 19311 with an IF filter/limiter approach. Also, the rolloff outside the 3 dB bandwidth should be rapid-like the sinc function.

In an attempt to approximate the rapid rolloff and linear phase characteristic of the sinc function filter, performance and spectrum was examined with the filter shown in Figure 8. Here a 4-pole Butterworth filter with 3 dB bandwidth equal to symbol rate and with two sections of all-pass phase compensation is included. The filter's primary function is to

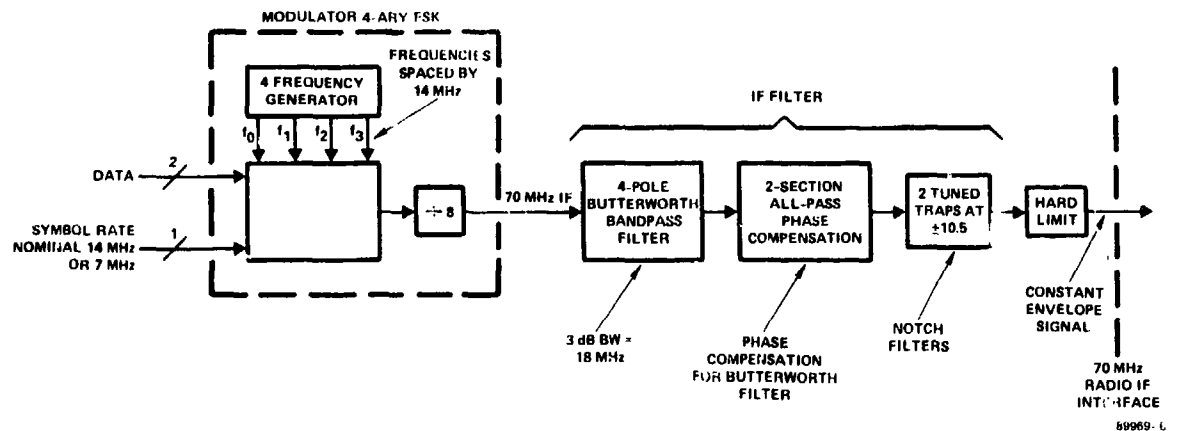

Figure 8. IF Filter Approach to FCC 19311

reduce higher order side lobes. The most significant main lobe filtering is done by the two tuned traps (zeros on $j\omega$ axis) at $\pm 0.75 \times$ symbol rate relative to carrier. These two zeros lead to parabolic frequency response between the two notch frequencies. The zeros also have the merit of theoretically creating no group delay distortion between the two notch frequencies. The overall attenuation and group delay distortion of this composite IF filter is shown in Figure 9. The 3 dB bandwidth of the filter is $0.375 \times$ bit rate. This composite filter was used as the baseline in the

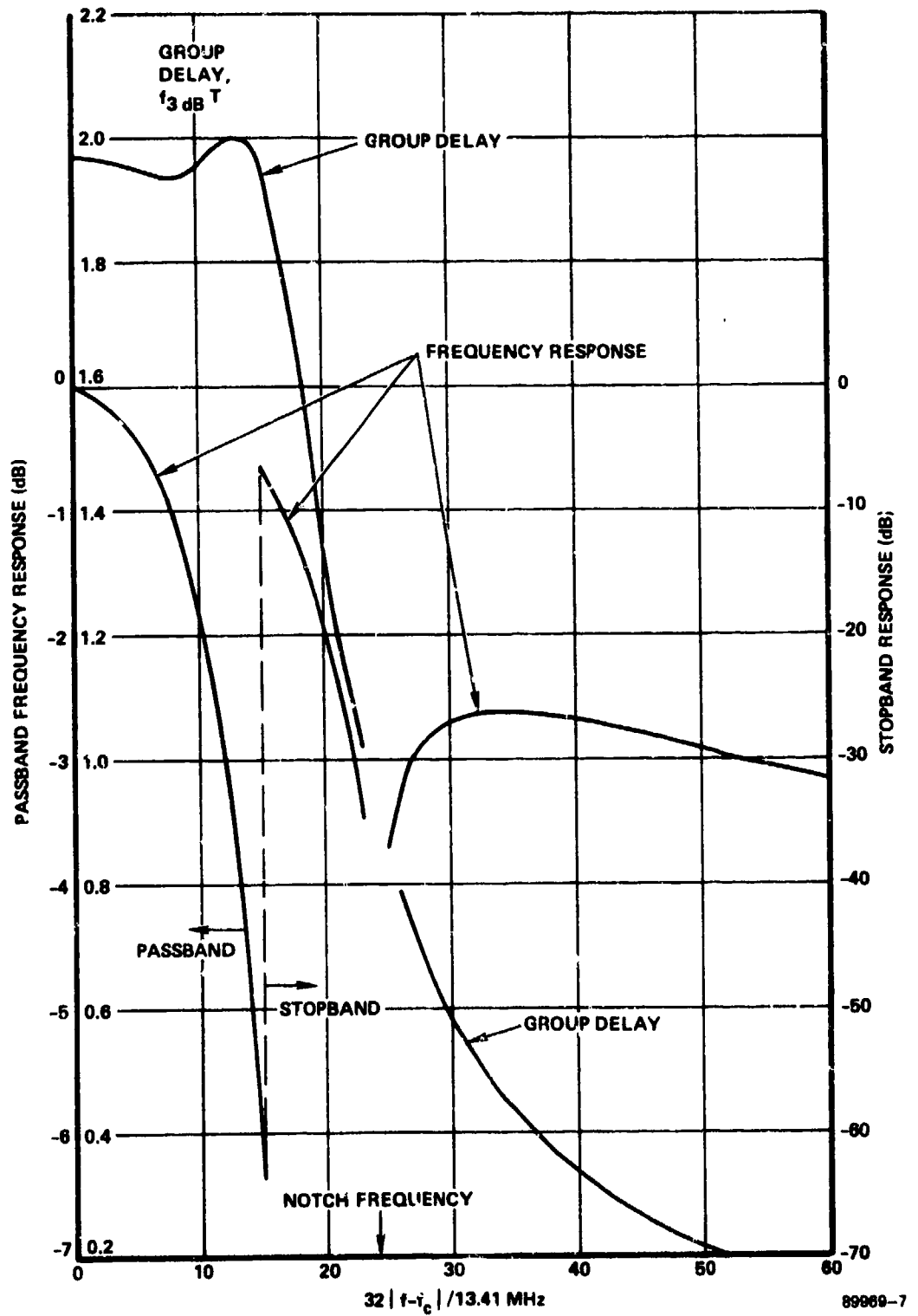

Figure 9. IF Approach Transmit Filter Characteristics

following results for the IF filter approach to FCC 19311 compliance. The radiated signal spectrum using this IF filter for 2 B/Hz operation is shown in Figure 10. The radiated signal spectrum for 1 B/Hz operation is shown in Figure 11. Both modes use the same IF filter and both operate in an authorized bandwidth of 1 MHz.

Figure 12 shows the computer performance predictions for the IF filter baseline approach. The nominal baseline conditions are given in Table 1.

The 2 B/Hz mode theoretically requires 23.1 dB E_b/N_0 for a 5×10^{-9} symbol error rate.

Figure 13 shows the variation in symbol error rate as the symbol timing at the demod varies.

Figure 14 shows the variation in symbol error rate as the threshold spacing in our demod crosstalk correction algorithm changes.

The sensitivities shown on these figures are roughly the same degree of sensitivity to imperfections as the prior breadboard modem. However, the performance with the IF filter approach shown in Figure 12 is approximately 2.3 dB worse than the performance of the waveguide filter approach presented in the following section. Consequently, the IF filter approach was discarded in favor of using the waveguide filter. The IF filter bandwidth required for FCC 19311 compliance was simply too narrow and resulted in excessive signal distortion relative to the waveguide filter approach.

At the end of the study phase it was discovered that the simulation which produced the performance curve for the IF filter approach shown in Figure 12 was producing optimistic predictions. Due to time limitations these simulations were not re-run. In any case, the trade-off between IF and waveguide filtering is weighted even more toward the waveguide approach.

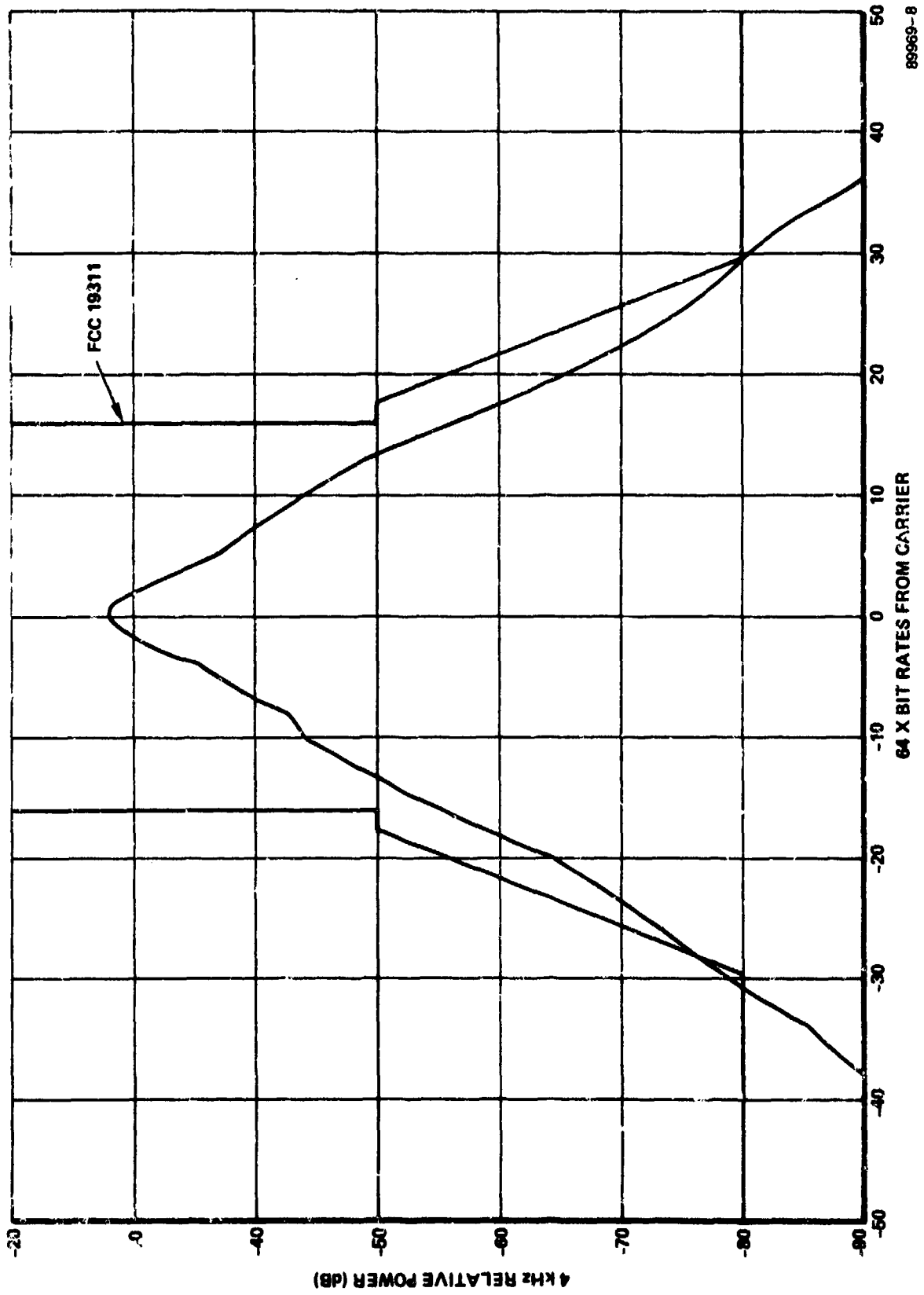

Figure 10. IF Approach 2 B/Hz Spectrum

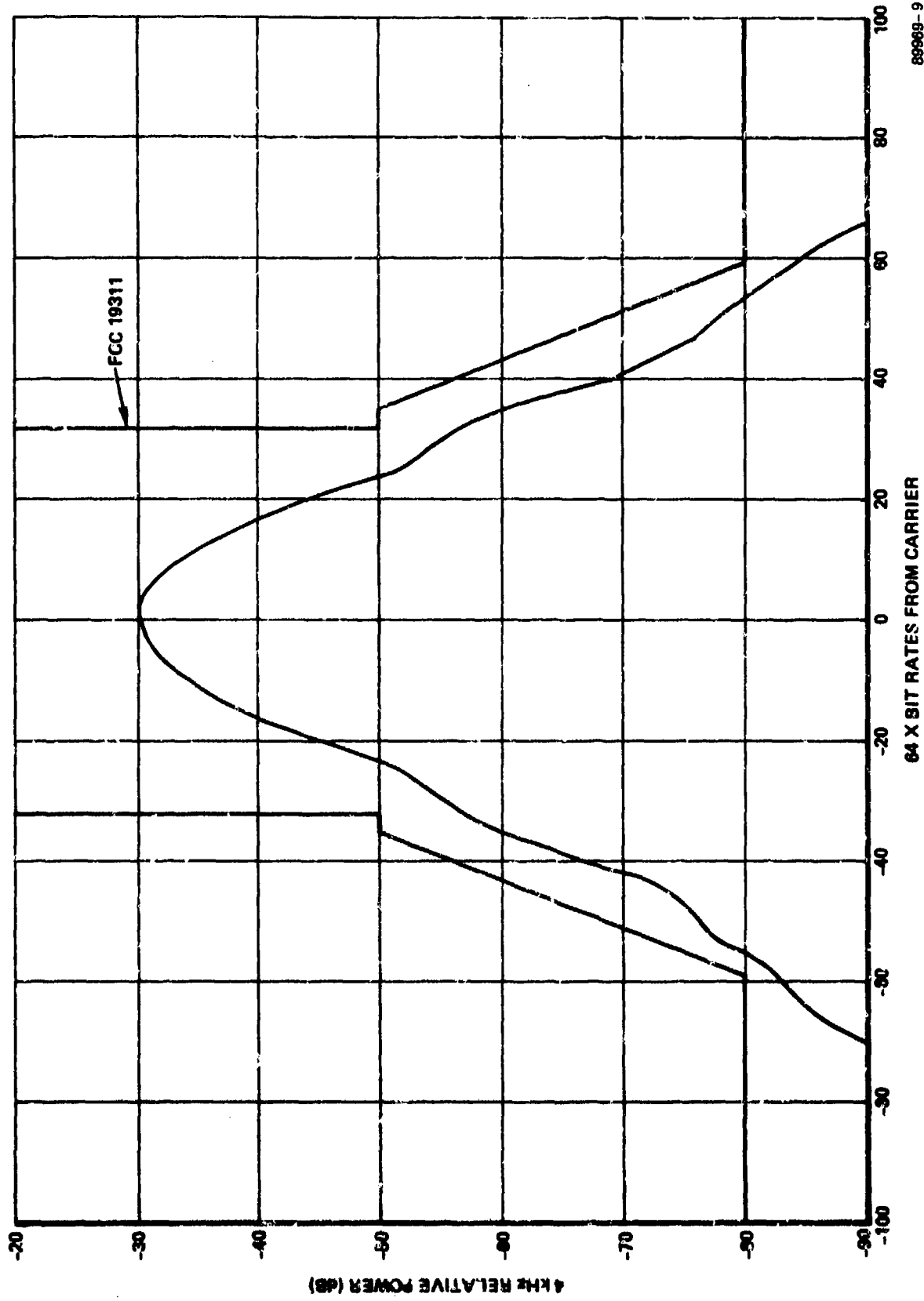

Figure 11. IF Approach 1 B/Hz Spectrum

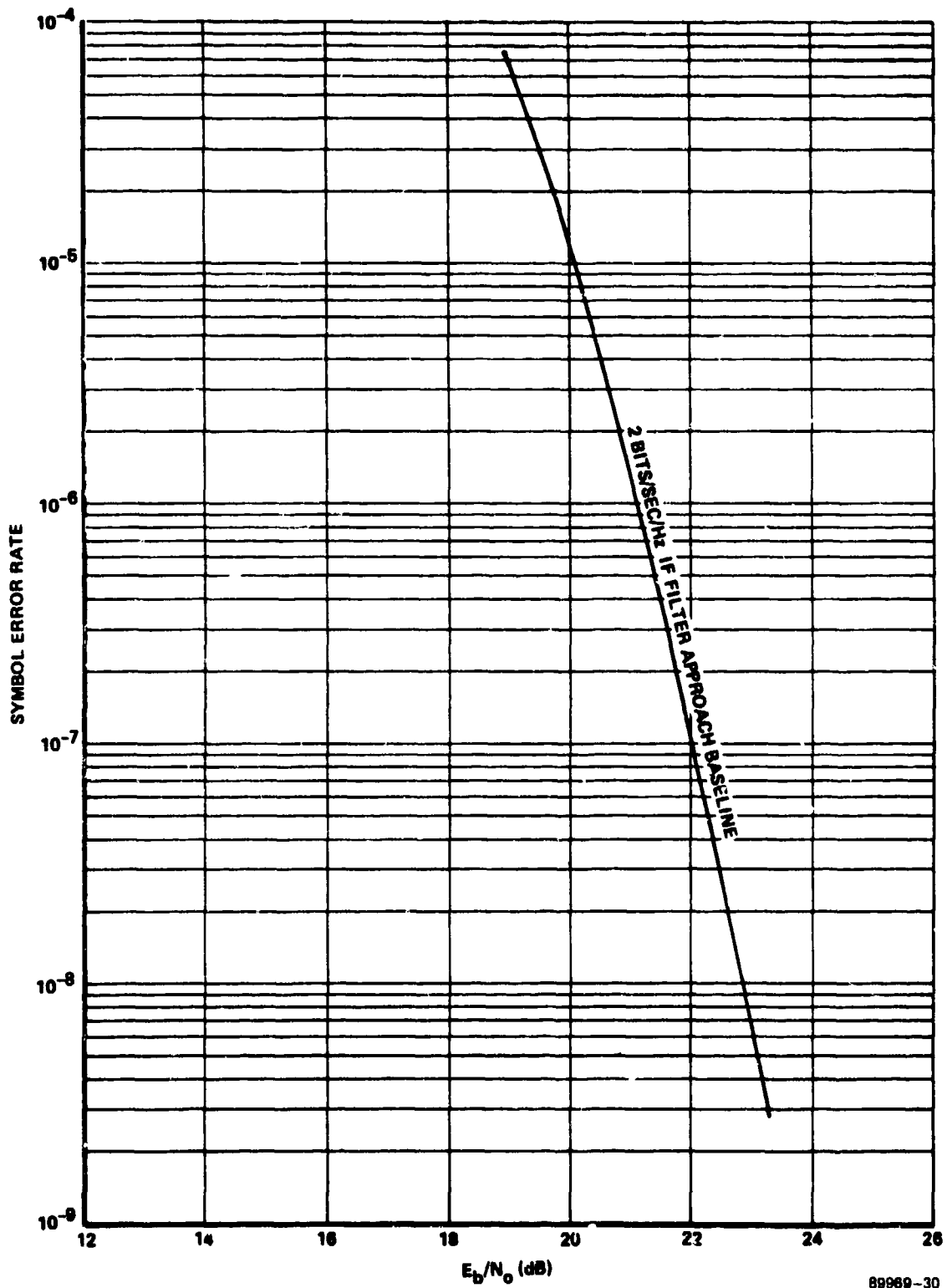

Figure 12. IF Filter Approach Performance

Table 1. Nominal Baseline Conditions for IF Approach

1. TRANSMIT IF FILTER: 4-pole Butterworth with 3 dB bandwidths of 13.41 MHz and containing two section all-pass phase compensation. Two tuned traps at 70 10.05 MHz.
2. RADIO TRANSMIT IF FILTERS: 3-pole 0.1 dB ripple Tchebycheff and 3-pole Butterworth both with 3 dB bandwidths of 30 MHz.
3. DEMODO IF FILTER: 4-pole Butterworth with 3 dB bandwidths equal to symbol rate and containing two section all-pass phase compensation.
4. CROSSTALK ALGORITHM THRESHOLD SETTING: $\theta = 5.5^\circ$.
5. REFERENCE LOOP PHASE JITTER: 0.7° rms.
6. SYMBOL TIMING: Within 1 percent of symbol time of best location.

2.3.1.2 Waveguide Filter Approach

In this section the study effort which considered the use of microwave waveguide filters for spectral shaping to meet FCC 19311 is presented.

2.3.1.2.1 Filter Characteristics

The nominal center frequency of the Philco LC8D radio used for testing the modem was 8.075 GHz. The filter attenuation characteristic needed for FCC 19311 compliance is primarily dictated by the 18 dB violation of the spectral mask for 2 B/Hz at symbol rate (one-half bit rate) removed from carrier. For this modem the nominal bit rate is 26.82 Mb/s. Thus the waveguide filter is centered at 8.075 GHz and must be at least 18 dB down at ± 13.41 MHz. Based upon computer simulations and consideration of waveguide filter types readily available in the industry, it was decided to use a 4-pole Butterworth filter with 3 dB bandwidth of 16 MHz for this approach. The use of such a filter results in near-optimum

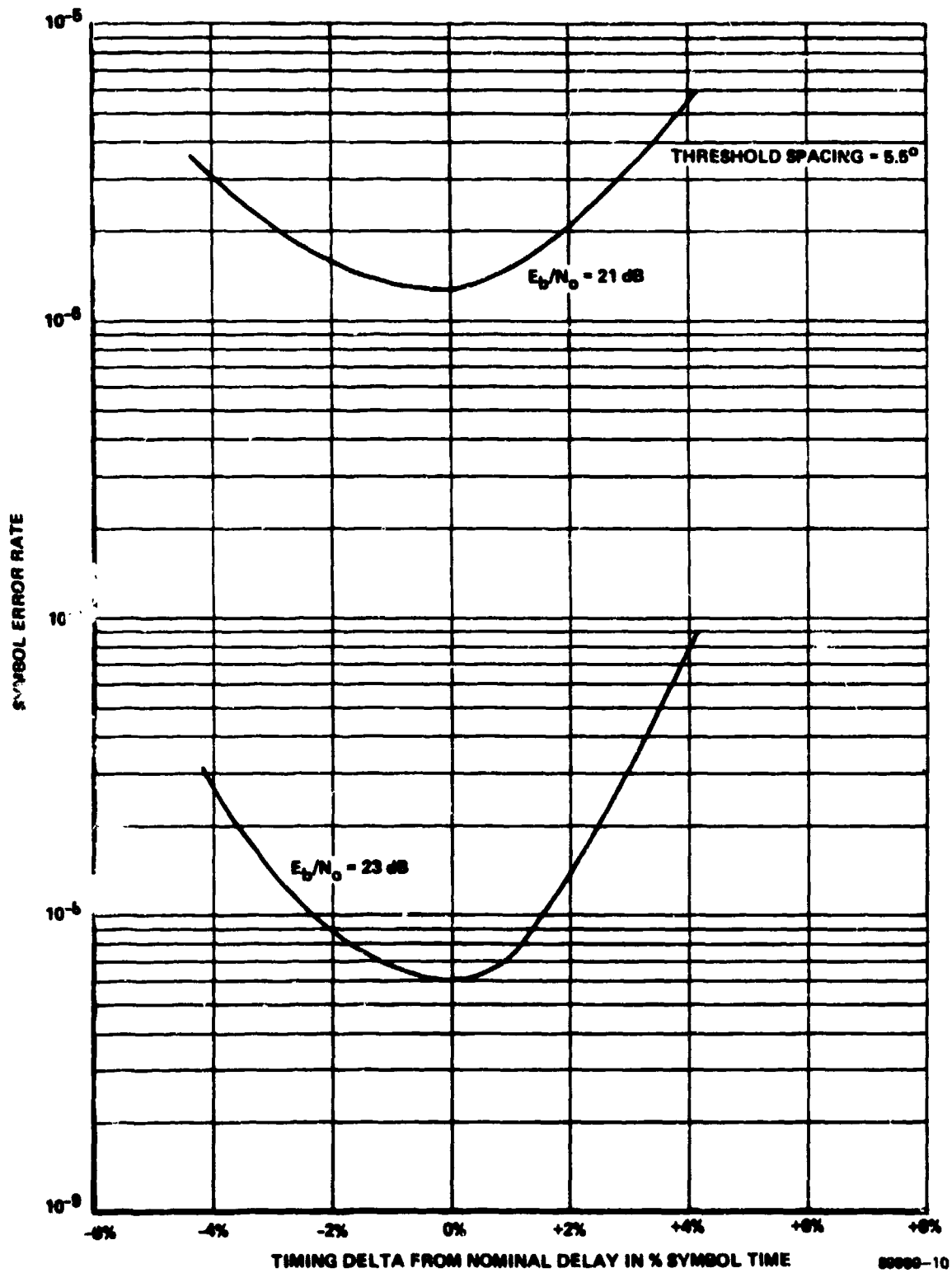

Figure 13. Nominal IF 19311 Approach Timing Sensitivity

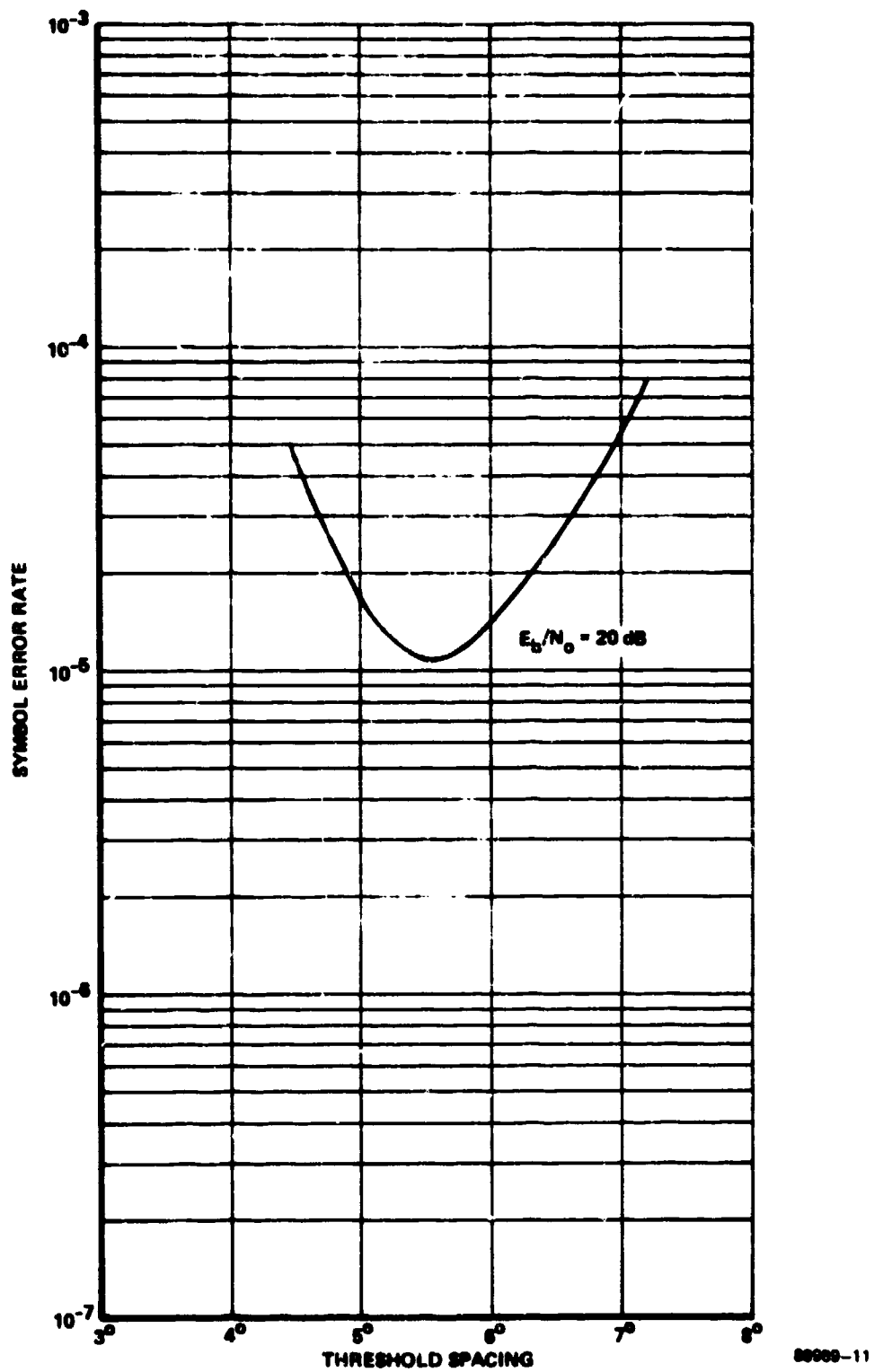

Figure 14. Nominal IF 19311 Approach Threshold Spacing Sensitivity

performance and leads to FCC 19311 compliance for both the 2 B/Hz and 1 B/Hz modes operating in an authorized bandwidth of 14 MHz. The attenuation and group delay distortion for this filter are shown in Figures 15 and 16 respectively. When the baseline radio filters are included, the overall attenuation and group delay characteristics are as shown in Figures 17 and 18 respectively.

Discussions with waveguide filter manufacturers (Microwave Development Laboratories (MDL) and Wavecom) revealed that INVAR construction of such a filter will lead to ± 400 kHz of center frequency detuning at 8 GHz and with $\pm 25^{\circ}$ C temperature variation. This detuning number results from assuming INVAR material has a temperature coefficient of expansion of $2 \times 10^{-10}/^{\circ}$ C. The formula indicated by MDL for computing detuning is

$$D = \epsilon f_c (\Delta T) \quad (1)$$

where D = Frequency detuning.

ϵ = temperature coefficient of expansion.

f_c = filter center frequency.

ΔT = temperature variation.

The assumption of $\pm 25^{\circ}$ C operating temperature variation is supported by reference to DRAMA specs (0° to 49° C) and to the Philco LC8D radio specs (0° to 50° C). Equation (1) then indicates

$$D = 2 \times 10^{-6} \times 8 \times 10^6 \times (\pm 25) \text{ kHz}$$

or $D = \pm 400$ kHz

2.3.1.2.2 Waveguide Filter Results

Figures 19 and 20 show the spectra obtained with the waveguide filter for the 2 B/Hz and 1 B/Hz modes respectively. The effect of transmitter detuning of ± 402 kHz is indicated on these figures. This ± 402 kHz frequency variation is the amount of detuning occurring in an 8 GHz waveguide filter of INVAR construction for a $\pm 25^{\circ}$ C temperature variation. These figures show that the spectra both will meet the FCC 19311 masks for

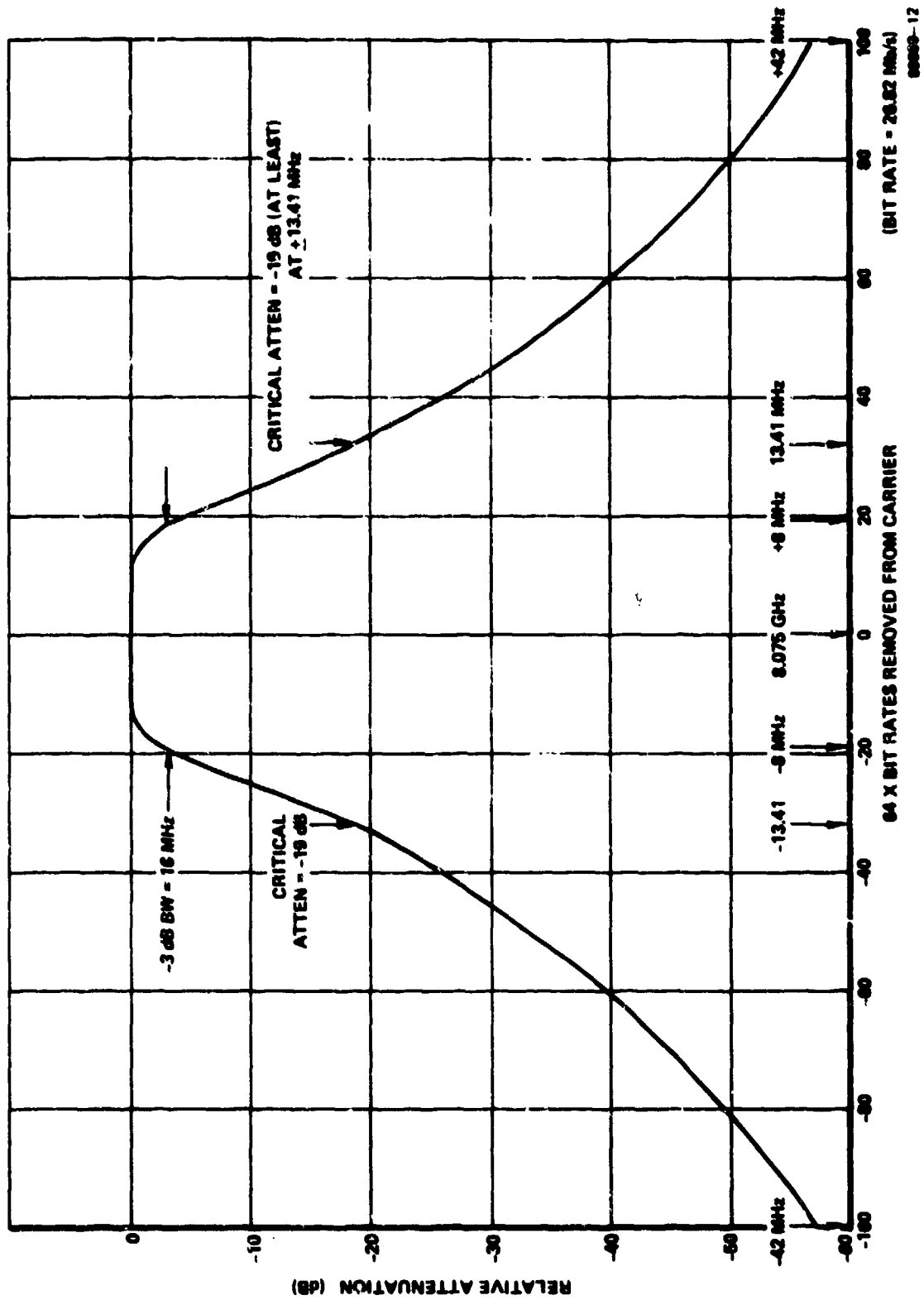

Figure 15. Four-Pole Butterworth Waveguide Filter Attenuation Characteristics

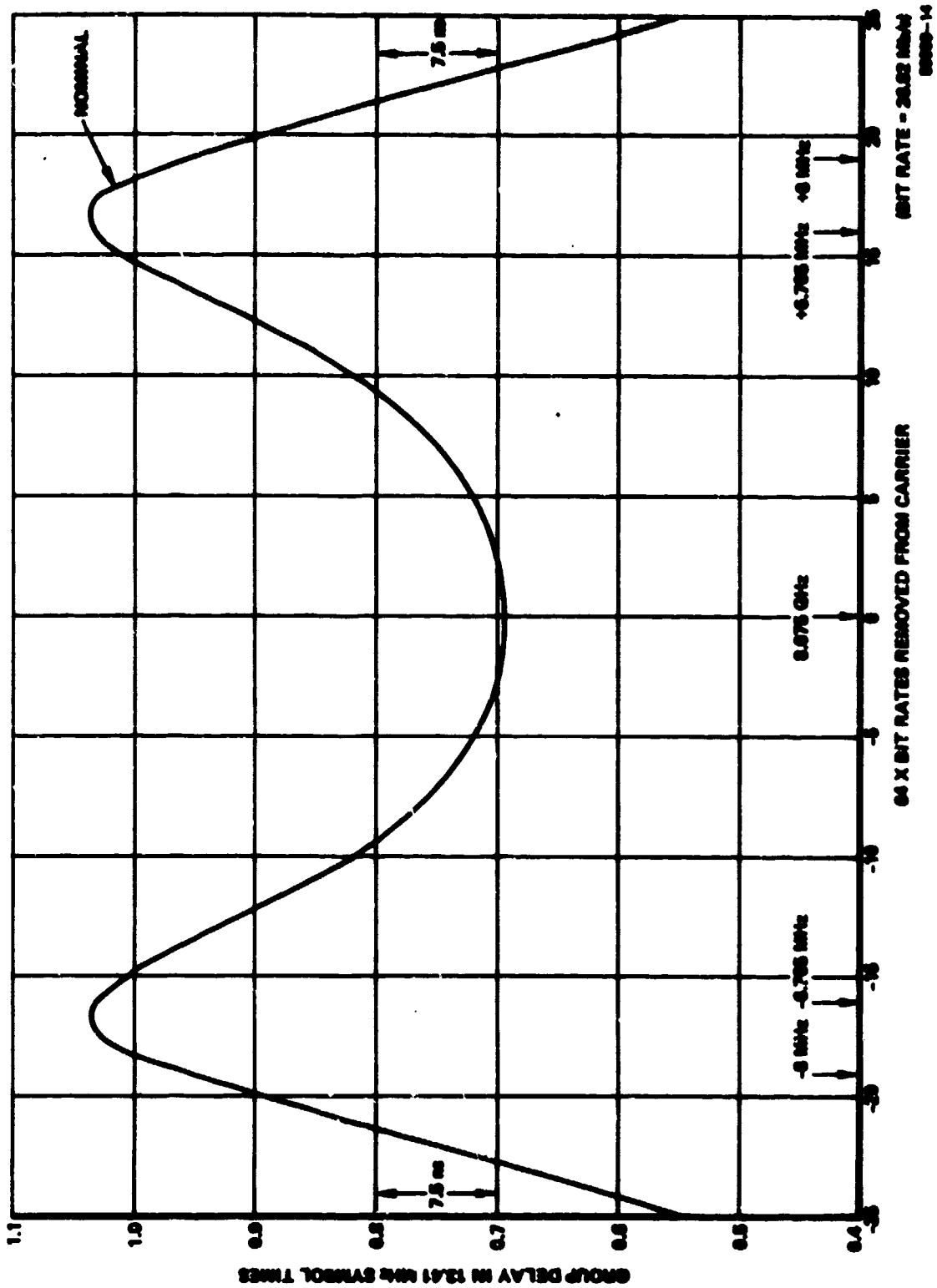

Figure 16. Four-Pole Butterworth Waveguide Filter Delay Distortion Characteristics

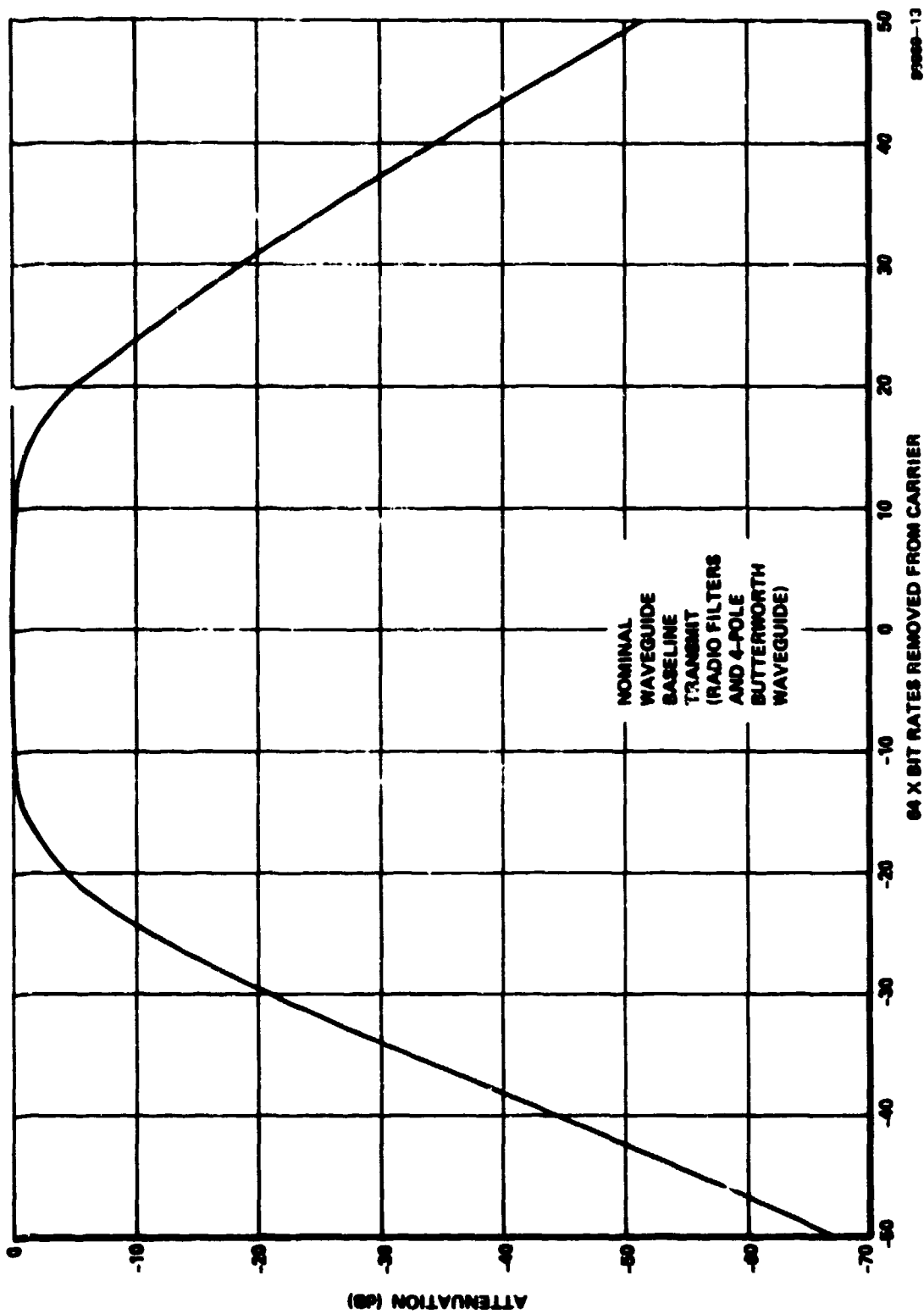

Figure 17. Nominal Waveguide Baseline Transmit Attenuation

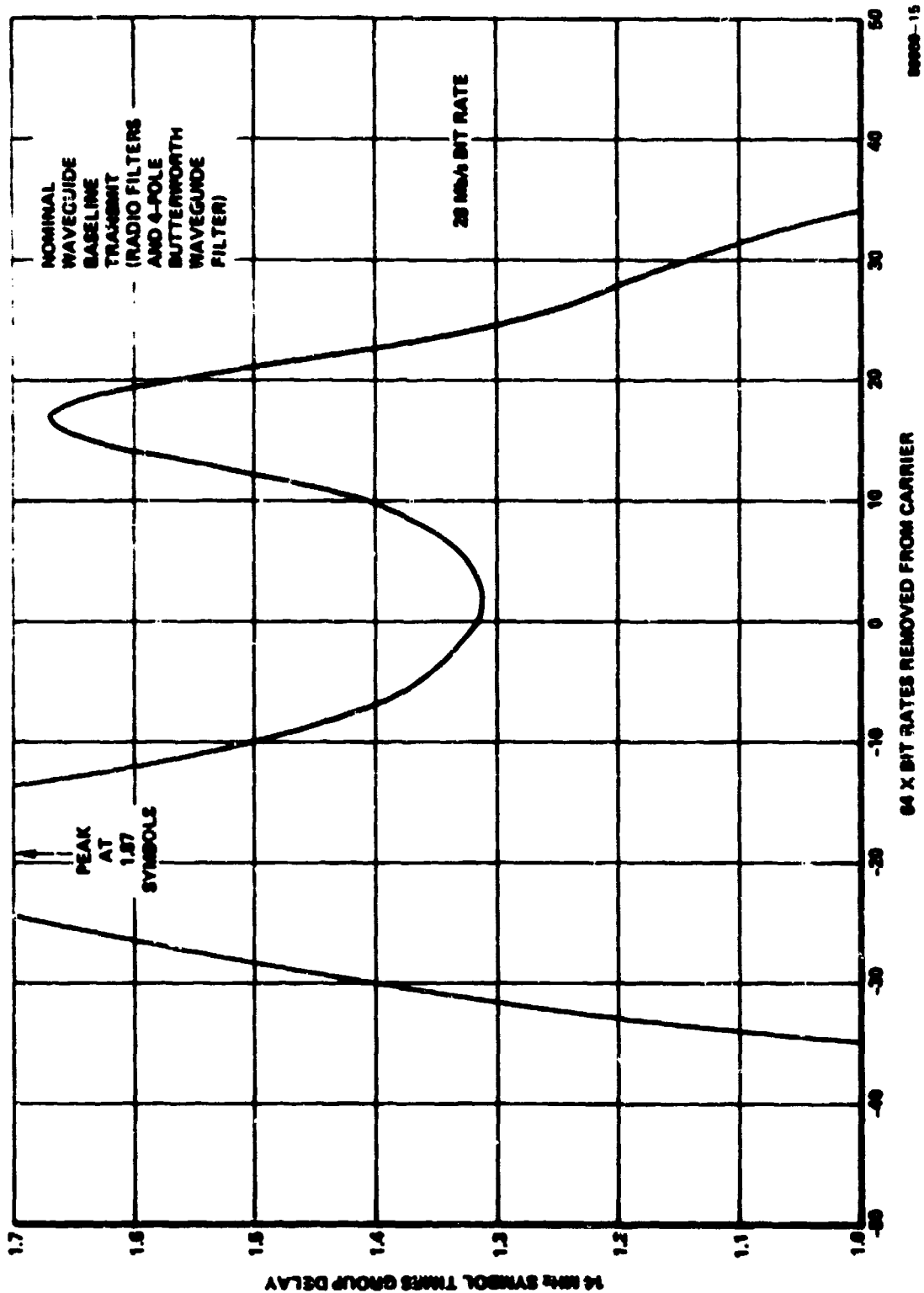
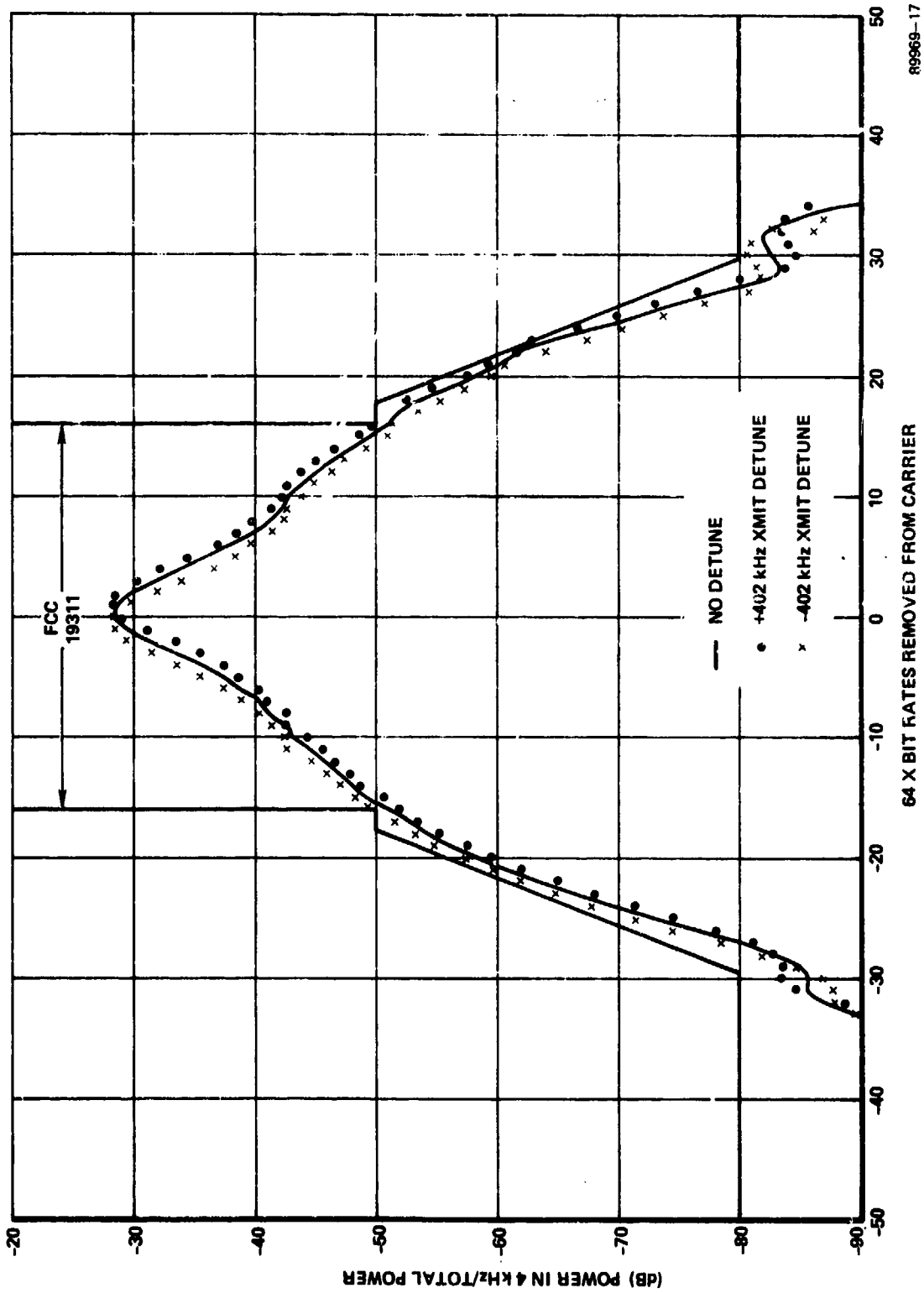

Figure 18. Nominal Waveguide Baseline Transmit Group Delay



89569-17

Figure 19. Waveguide Approach 2 B/Hz Spectrum

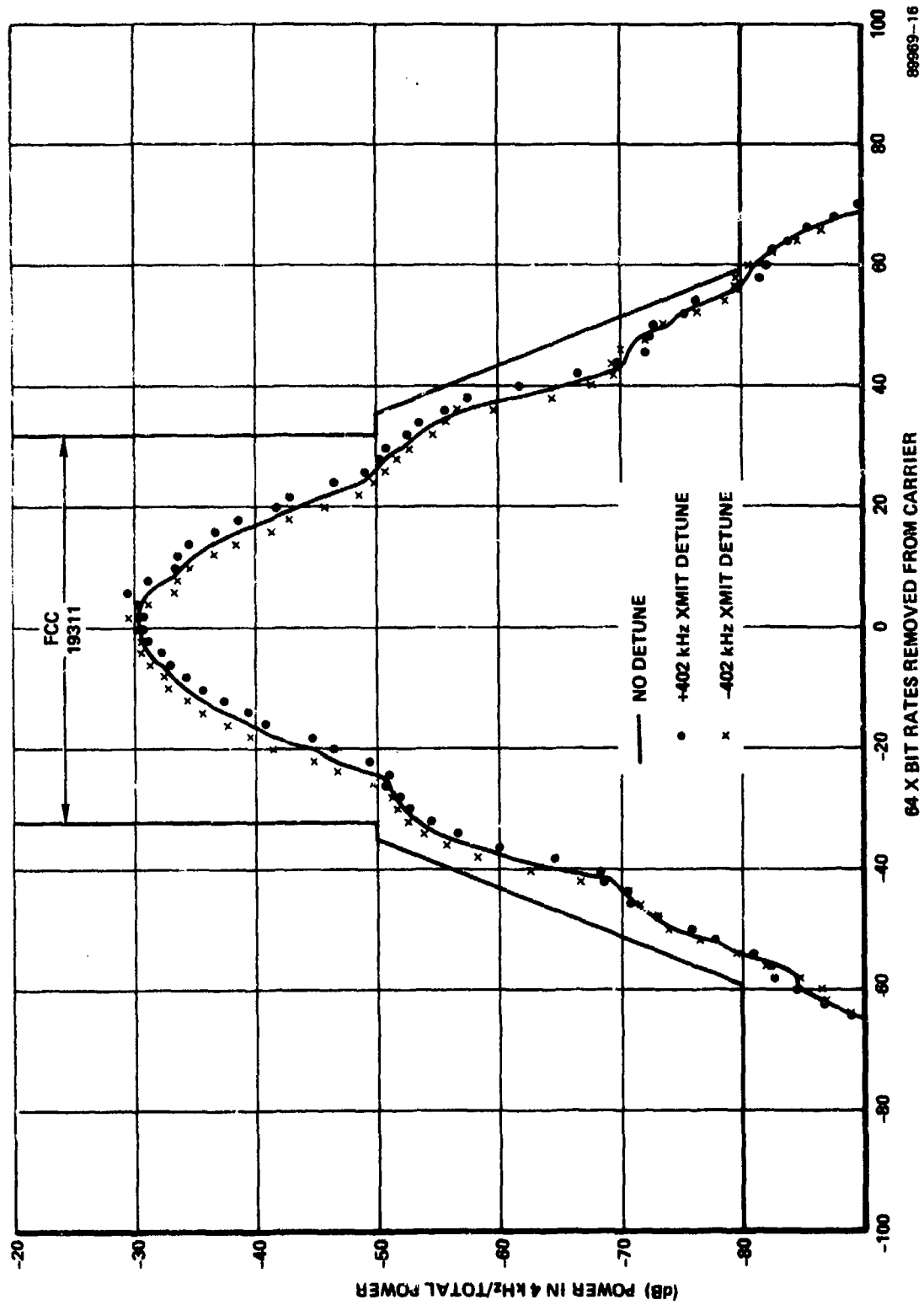

Figure 20. Waveguide Approach 1 B/Hz Spectrum

$\pm 25^{\circ}$ C temperature variation with a waveguide filter of INVAR construction. It is impossible - both from performance and spectra viewpoints - to use non-INVAR construction since center frequency shifts an order of magnitude greater would occur (± 4 MHz) over this temperature range.

Figure 21 shows the performance for the waveguide filter baseline approach. The nominal conditions for the baseline are given in Table 2. As shown, 2 B/Hz operation at 5×10^{-9} error rate requires 20.8 dB E_b/N_0 while 1 B/Hz operation requires 14.3 dB E_b/N_0 . These predictions are roughly 3 dB better than the performance predicted for the IF filter approach. Figure 22 shows the performance of the modem back-to-back at IF, i.e., without the waveguide filter.

Figure 23 shows the variation of symbol error rate with detuning. This curve is important in comparing the detuning effect versus temperature for the waveguide filter against performance degradation to be expected. As indicated in Figure 23 the symbol error rate degrades by less than a factor of 2 for ± 402 kHz detuning. This represents less than 0.2 dB signal-to-noise degradation at a 5×10^{-9} bit error rate.

Figure 24 shows the variation of symbol error rate with changes in threshold spacing at the crosstalk algorithm.

Figure 25 shows the variation in symbol error rate with demod symbol timing variation.

Again, the indicated sensitivities to equipment imperfections is comparable to the previous breadboard sensitivities. Because of the better performance available with the waveguide filter approach to FCC 19311 spectral compliance, the waveguide was chosen for the baseline for this modem.

2.3.2 New Implementation Techniques

This section documents the study effort which investigated new implementation techniques for the modem. The effort centered primarily upon reconfiguring the phase detector reference derivation to eliminate critical phasing, timing, and acquisition problems encountered in the previous breadboard unit.

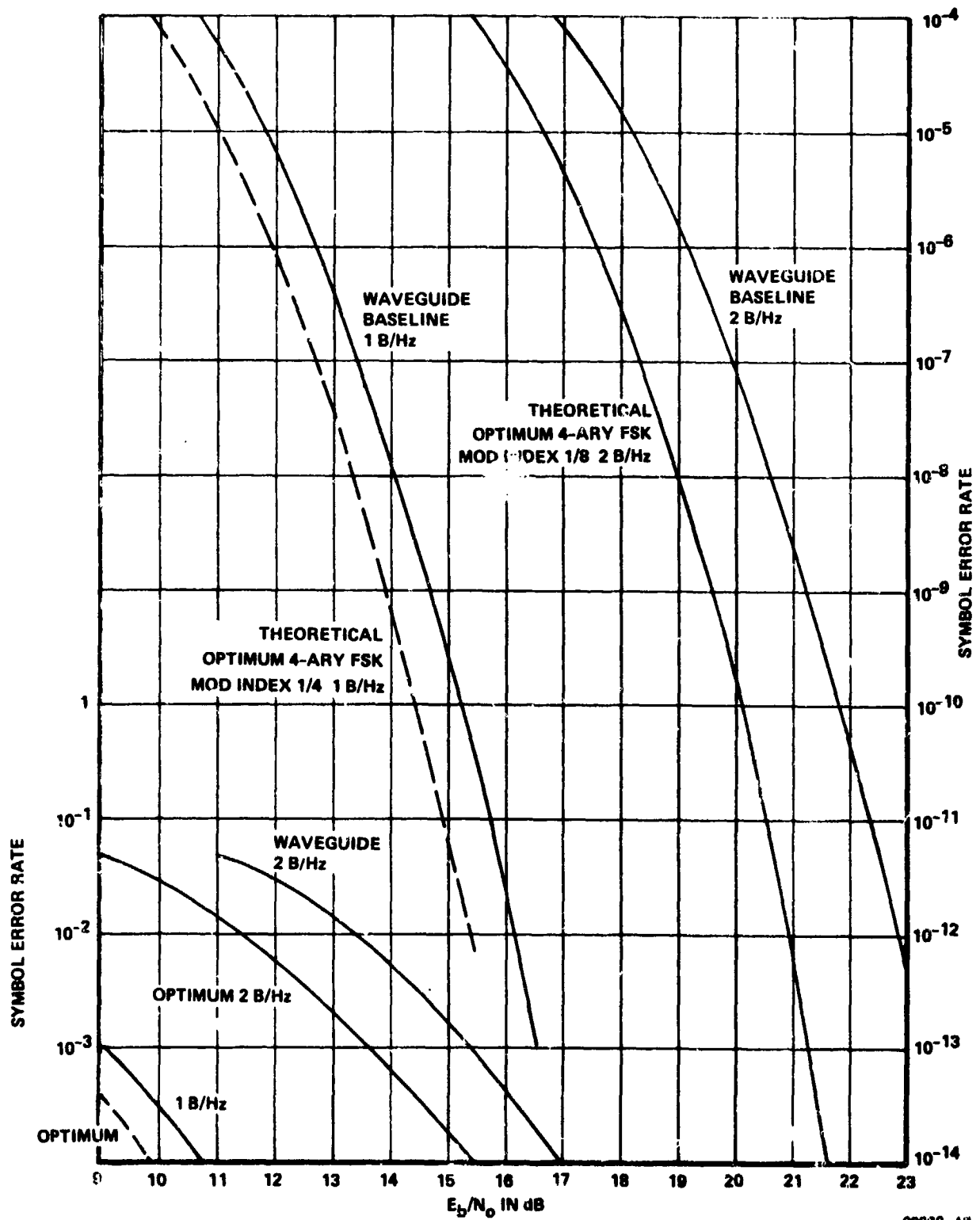

80939-18

Figure 21. Waveguide Approach Baseline Performance

Table 2. Nominal Baseline Conditions for Waveguide Filter Approach

1.	<u>RADIO TRANSMIT IF FILTER:</u>	3-pole 0.1 dB ripple Tchebycheff and 3-pole Butterworth - both with 3 dB bandwidths of 30 MHz.
2.	<u>WAVEGUIDE FILTER:</u>	4-pole Butterworth with 3 dB bandwidth of 16 MHz.
3.	<u>DEMODO IF FILTER:</u>	4-pole Butterworth with 3 dB BW equal to symbol rate containing two section all-pass phase compensation.
4.	<u>CROSSTALK ALGORITHM THRESHOLD SETTING:</u>	$\theta = 5^\circ$.
5.	<u>REFERENCE LOOP PHASE JITTER:</u>	0.7° rms.
6.	<u>SYMBOL TIMING:</u>	Within 1 percent of symbol time of best location.
7.	<u>WAVEGUIDE FILTER DETUNING:</u>	0.

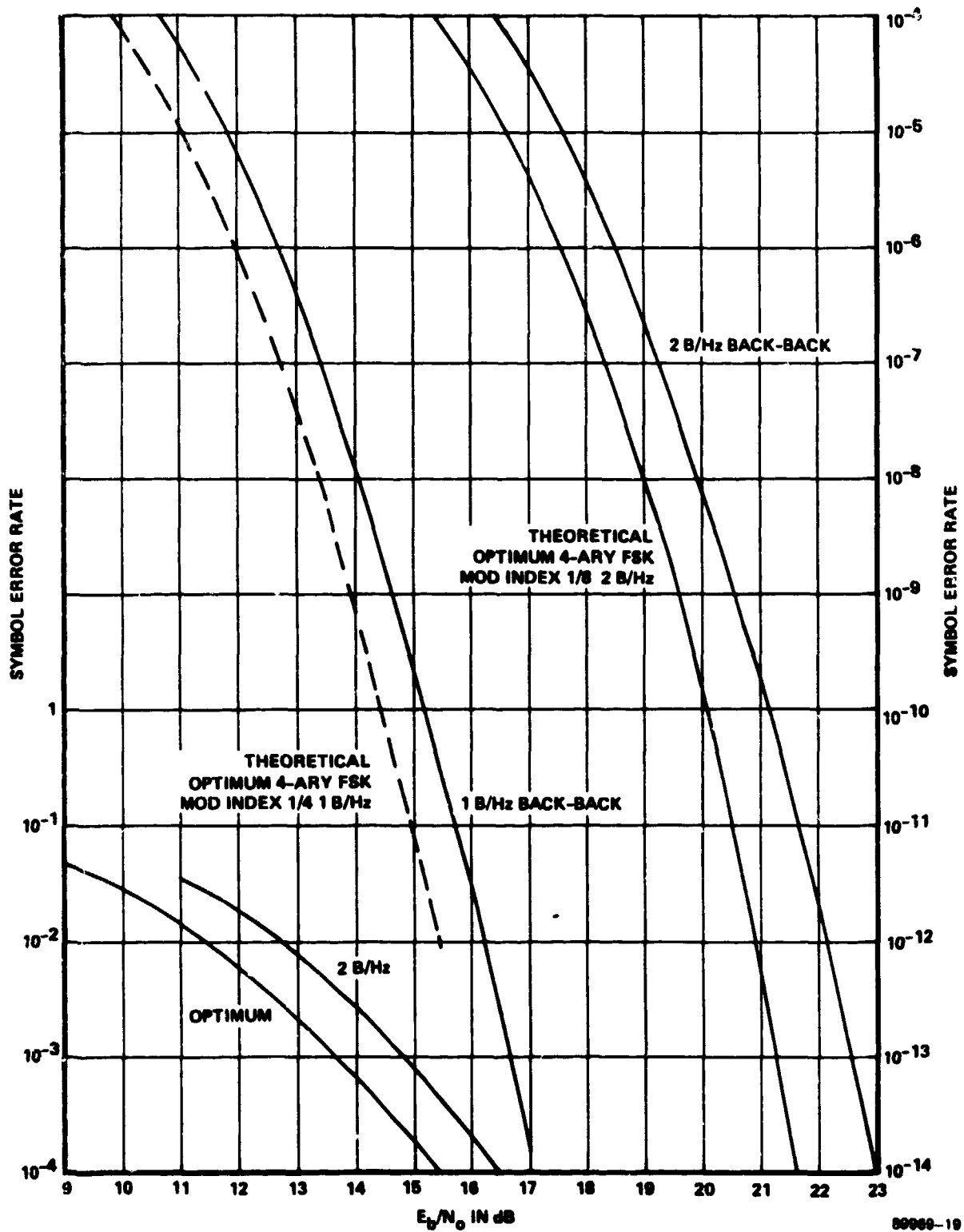

Figure 22. Back-to-Back Waveguide Baseline (Without Filtering)

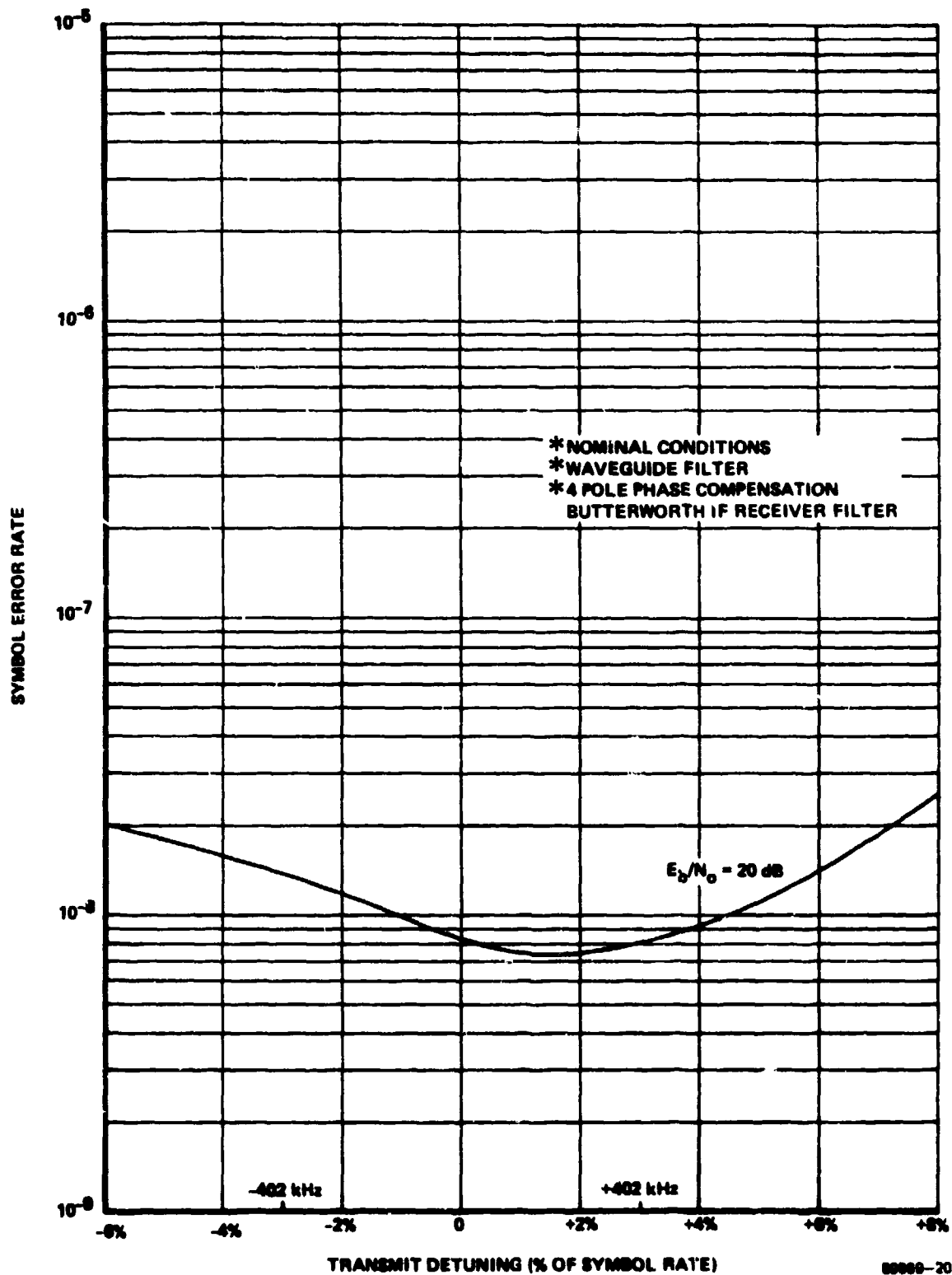

Figure 23. Waveguide Approach Detuning Sensitivity

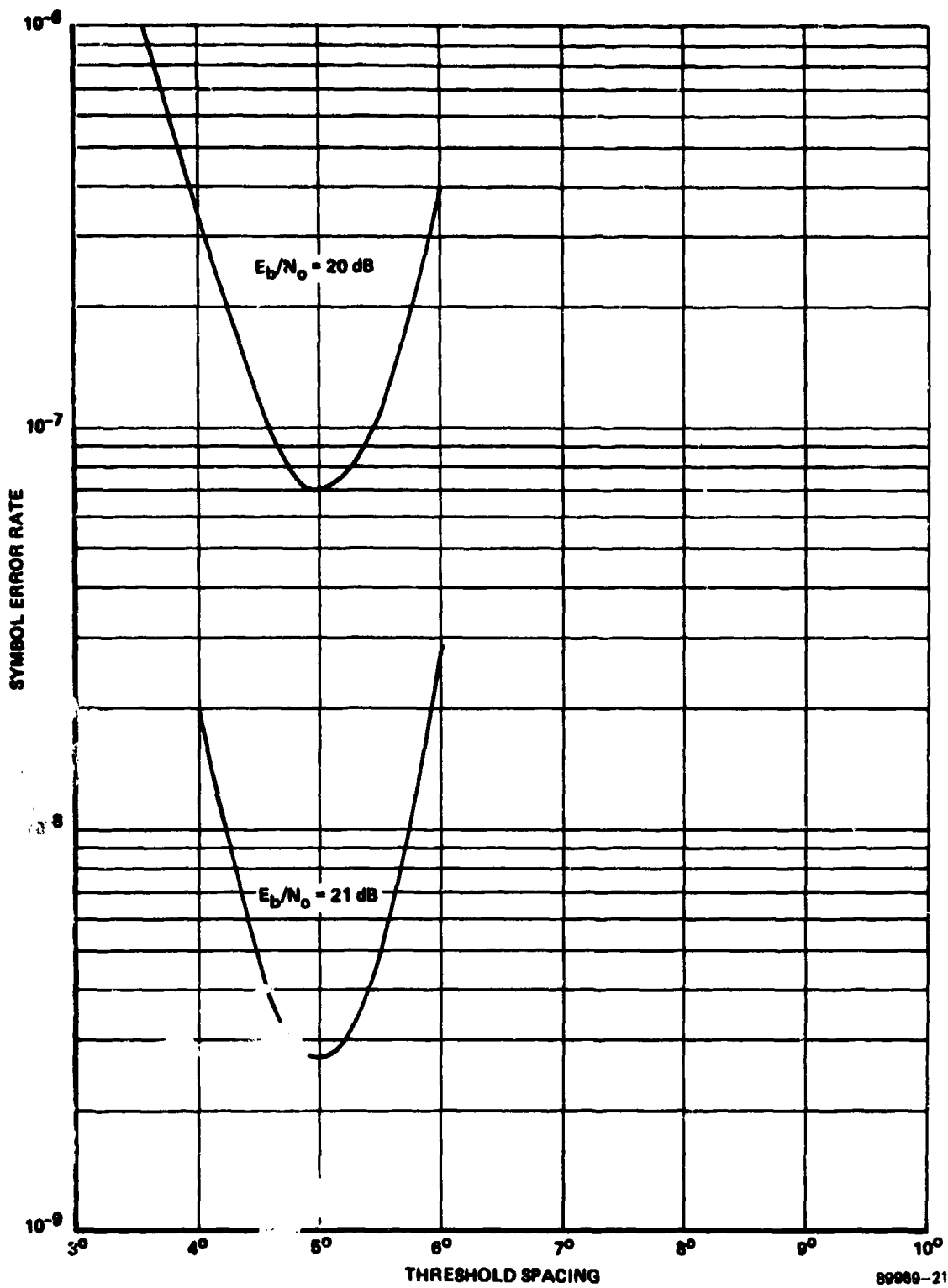

Figure 24. Waveguide Approach Threshold Spacing Sensitivity

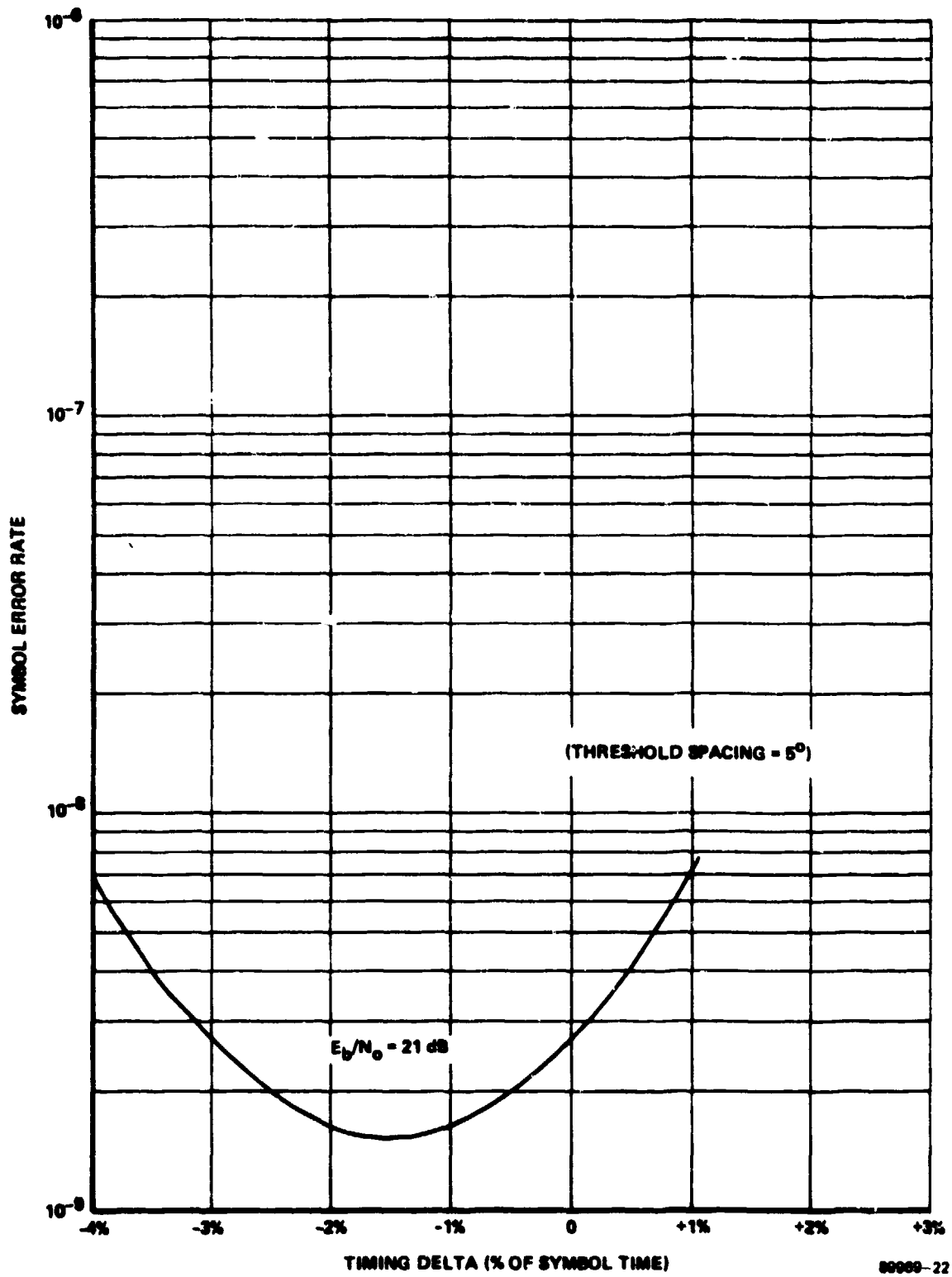
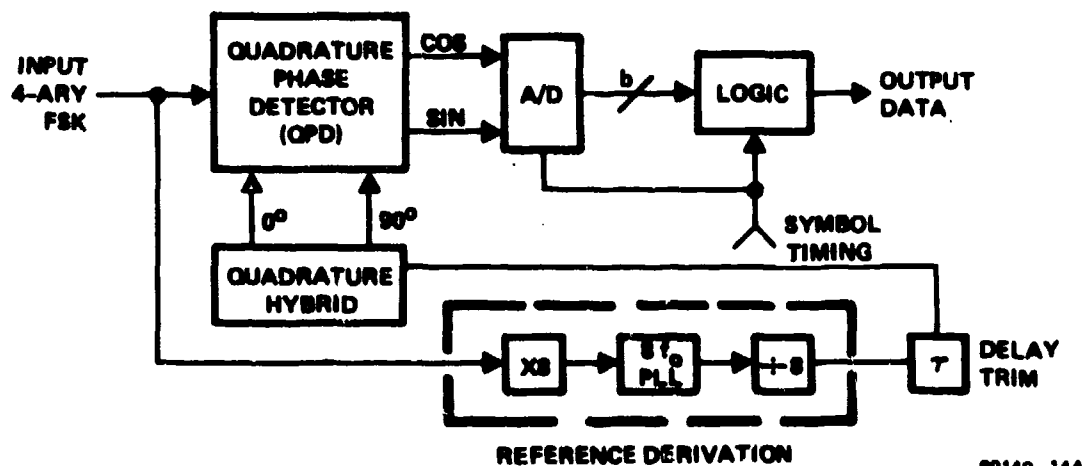

Figure 25. Nominal Waveguide Baseline Timing Sensitivity

2.3.2.1 The Phase Detector Reference Problem

The original breadboard had some severe implementation problems which resulted in critical timing adjustments. The most severe problems arose from the technique employed to generate and use the coherent reference for the quadrature phase detector (QPD).

Figure 26 shows a basic conceptual block diagram of the prior breadboard demodulator. Conceptually, the demodulator functions as follows. A reference is established at the lowest of the four transmitted



88149-14A

Figure 26. Simplified Diagram of Breadboard Phase Detection Technique

frequencies, f_0 . This reference is used to provide phase measurements from the QPD. These phase measurements are quantized in the A/D converter and provided to digital logic which estimates the transmitted frequencies, taking into account any crosstalk generated by system filtering.

The phase detector reference loop in the breadboard operated open-loop from the phase measurements being derived with that reference which resulted in significant critical timing problems. In Figure 26, note that the reference is derived in a $\times 8$ frequency multiplier chain followed by a phase-locked loop (PLL). Because of inherent delays that arise in various paths of the circuit, a time delay trim, τ , is required to properly align the phase of the reference. If everything were ideal (in particular

if time delays remained fixed) the system as shown would be satisfactory. However, with any variation leading to differential time delay between the QPD input and its reference, the reference is no longer coherent. It is believed that the intolerance of the previous breadboard to frequency offset could be traced to the fact that such offset resulted in changes in the differential time delay between the reference and QPD input. The following describes the steps taken to eliminate this problem in the present modem.

The possibility of making the QPD provide the error signal for controlling the phase of the reference VCO in a closed-loop manner as shown in Figure 27 has been investigated. As shown, the QPD outputs are observed and a phase measurement is noted. From this phase measurement a phase error to the closest FSK signal phase node can be calculated. For mod-index equal 1/8 FSK, the possible symbol-end phase nodes are spaced by 45° . The phase error signal so generated is filtered and used to control the VCO as shown.

An advantage of this type reference loop is that the reference is controlled to cause the phase error to the nearest node to average zero - where the phase error is based upon the actual phases measured in the QPD and not in an independently operating reference derivation loop. The coherence of the reference is thus guaranteed in a closed-loop manner.

During the study phase, attention was focussed on a scheme for deriving the phase error measurement described above from the existing phase detector thresholds in the demodulator. Figure 28 shows the manner in which the QPD quantizes the phase measurement for use in the logic processing circuitry. Ten thresholds are established on each of the two quadrature outputs. As shown in Figure 28 these thresholds allow 5 phase thresholds spaced by approximately 5° between each of the ideal ending phase nodes. Figure 29 shows a representative ideal phase node and the phase bins within $\pm 22.5^{\circ}$ of this node implied by the QPD thresholds of Figure 28.

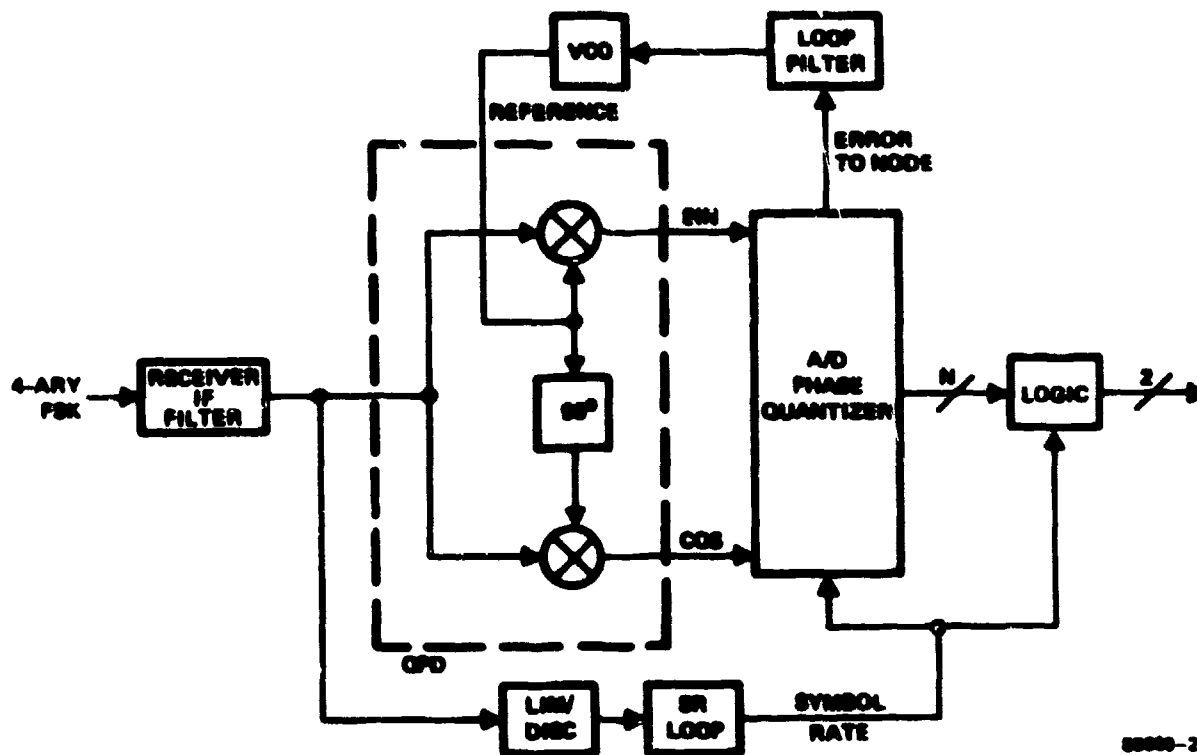

8888-23

Figure 27. Closed Loop Reference Derivation

An error signal is derived from the existing slicing levels wherein the phase error is assigned a value proportional to the distance of the phase bin from the ideal node. Figure 29 shows that the 5 phase errors associated with the 5 bins are 0 , $\pm 15^\circ$, and $\pm 20^\circ$. This is a rather coarse quantization of the phase error.

Computer simulations were run to observe acquisition time, loop-caused phase jitter, and symbol error rate obtainable with the scheme which filters the coarse phase error signal to control the reference VCO. Figure 30 shows the results obtained. The various quantities of interest are plotted versus the natural frequency, ω_n , of the closed loop. The loop damping factor was held constant at unity as the natural frequency was

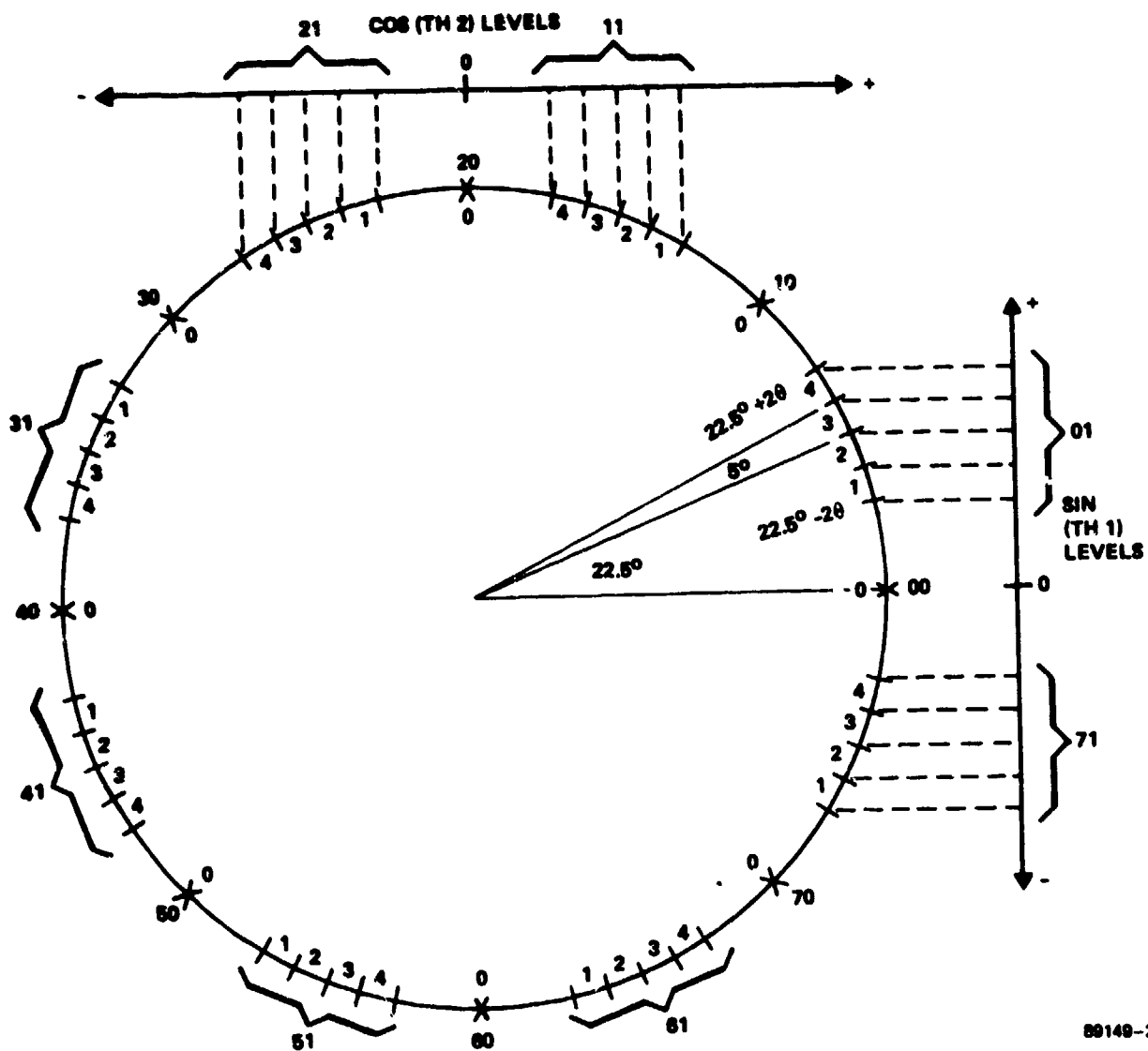

89149-2

Figure 28. Threshold Settings

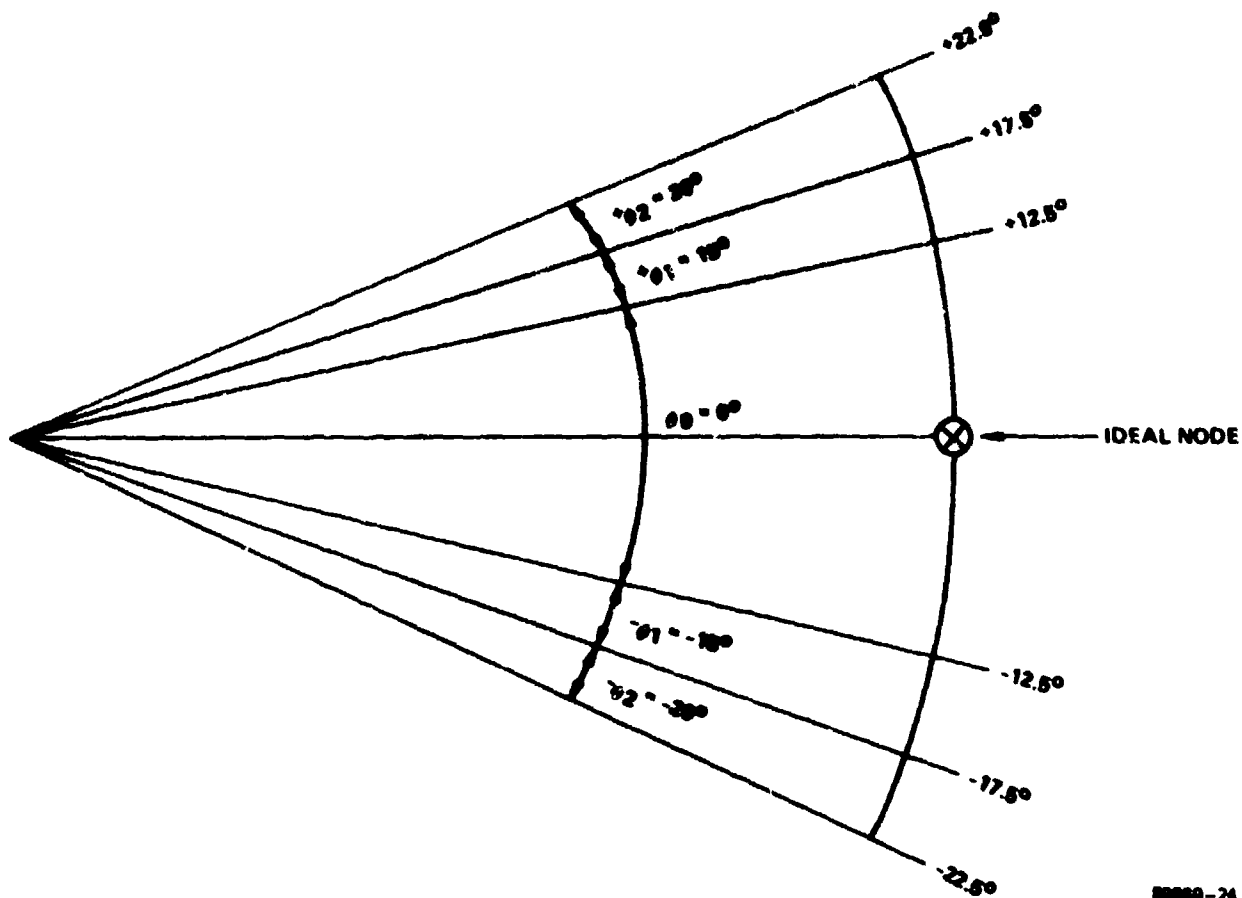

Figure 29. A Representative Ideal Node and Surrounding Phase Bins With the Thresholds of Figure 28

varied. The acquisition time varies rapidly with ω_n ($\sim \omega_n^{-3}$). The acquisition time plotted is for 80 kHz of initial frequency offset. E_b/N_0 for all curves is 20 dB.

To achieve the design goal of 1 ms acquisition time for 80 kHz offset, it is apparent from Figure 30 that the loop bandwidth will have to be set at a fairly large value (at least 70 to 80 kHz ω_n) and then after acquisition switch to a narrow bandwidth (ω_n approximately 10 kHz) to reduce rms loop-caused phase jitter to a desirable level of 0.7° .

The basic block diagram for the closed-loop reference derivation scheme demodulator is shown in Figure 31.

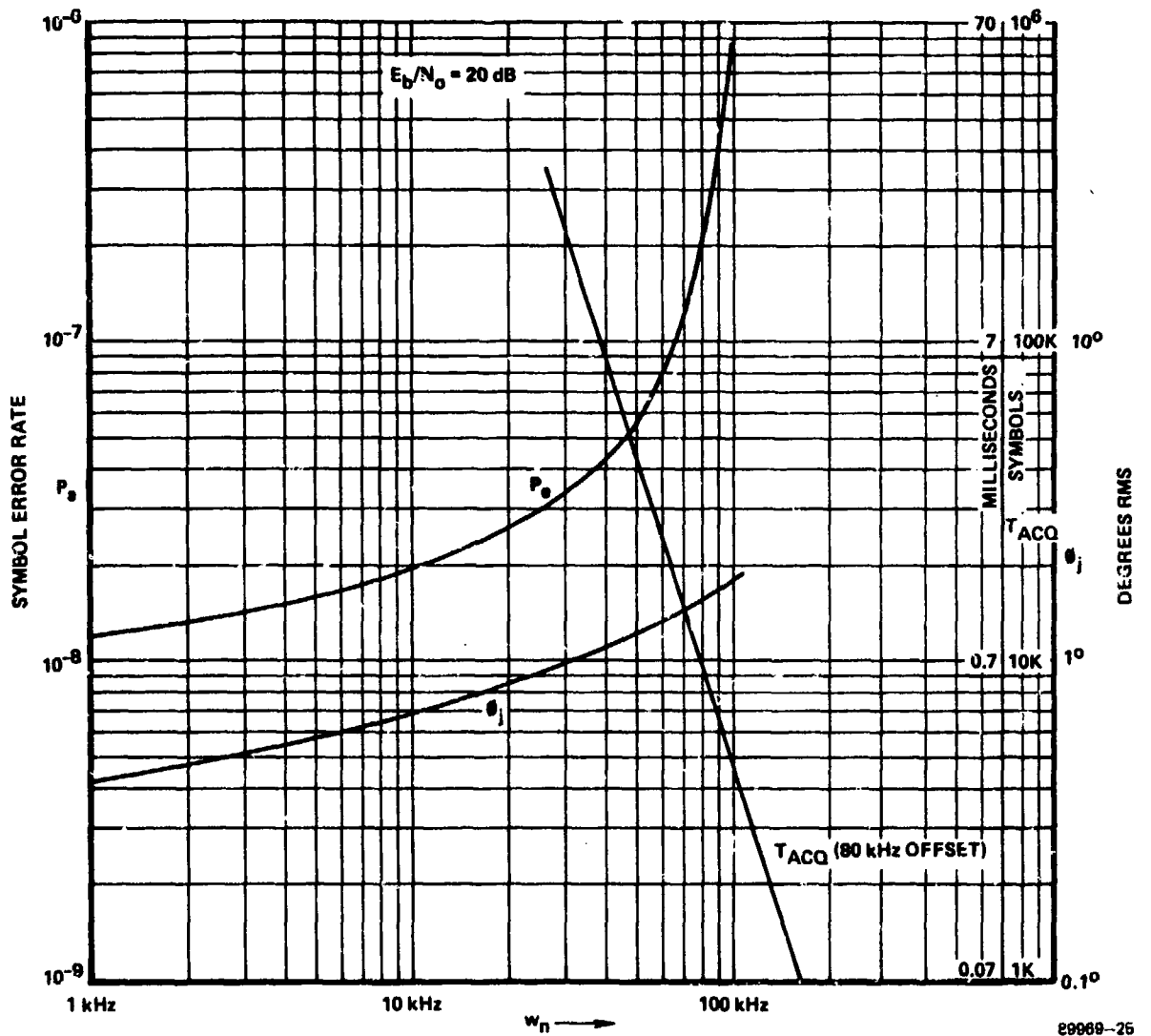
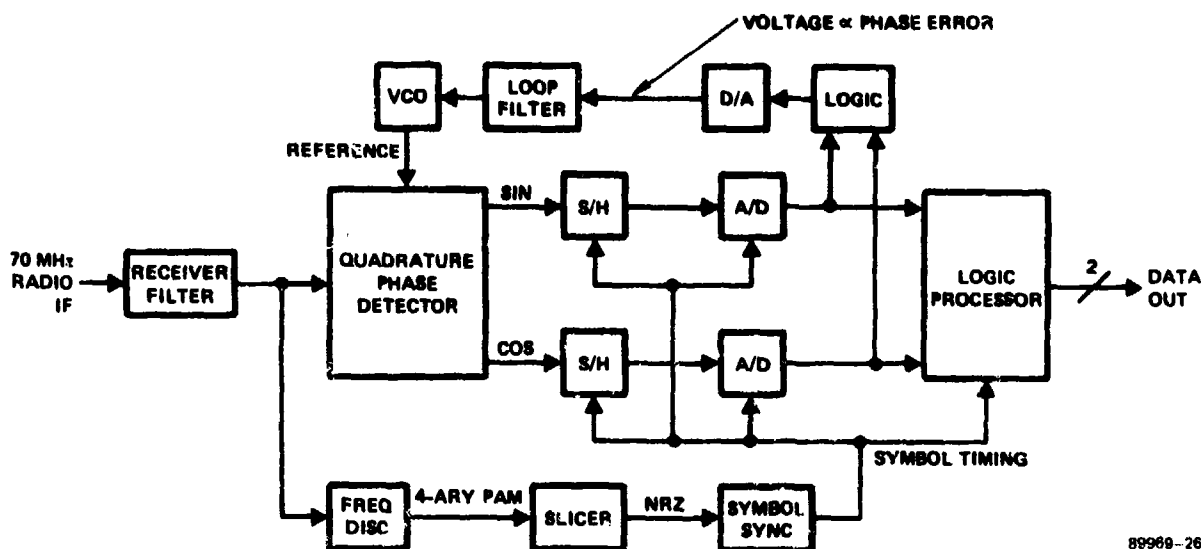

Figure 30. Closed Loop Phase Reference Scheme Characteristics



89969-26

Figure 31. Phase Detector - Demod for 4-ary CPFSK

The good results for the relatively simple closed loop scheme just described made the other more complex schemes that were considered look very unattractive and they were quickly discarded.

2.3.2.2 The Acquisition Problem

The primary acquisition problem occurs with the quadrature phase detector reference loop. The original goal was 1 ms acquisition with 80 kHz of frequency offset.

With 80 kHz frequency offset, the closed-loop technique described above requires a loop bandwidth of approximately 100 kHz to acquire in 1 ms. This loop bandwidth results in degradation due to excessive phase jitter of roughly two orders of magnitude in error rate. Thus, it is necessary to switch to a narrower loop following acquisition in order to reduce the jitter. Simulation indicated that a loop bandwidth of

approximately 10 kHz is required to reduce jitter to a desired level of 0.7° rms.

The provision of two different loop bandwidths is a complicating factor in the implementation. Not only are there special implementation problems brought on by the necessity to switch loop filters, but also the requirement for acquisition loop bandwidth of 100 kHz reflects into a requirement (from stability considerations) for a crystal VCO response bandwidth which stresses the capabilities of such VCO's.

It was desirable to eliminate the requirement to switch between two different loop bandwidths brought on by the 1 ms design goal. Several alternative approaches follow:

1. Increase the allowable acquisition time for 80 kHz frequency offset.
2. Reduce the frequency offset and keep 1 ms acquisition time.
3. Combination of reduced frequency offset and greater than 1 msec acquisition.

These three alternatives are summarized in Table 3. These numbers are generated from the computer simulation shown in Figure 30 and assuming that acquisition behavior is as in a second order phase-locked loop (which our closed-loop scheme is), i.e., $T_{acq} \propto (\Delta f)^2 \omega_n^{-3}$ where Δf is frequency offset and ω_n = loop natural frequency.

Frequency stability of 10^{-7} would hold frequency offset to under 1 kHz at 8 GHz and such stability would allow one loop bandwidth acquisition in 1 ms and no baseline degradation.

In consultation with RADC an assumption of 20 kHz frequency offset and 20 ms goal on acquisition was adopted. A single loop bandwidth of 14 kHz which as indicated by the bottom line in Table 3 results in no more than 0.1 dB baseline degradation was implemented.

Table 3. Effect of Changing Acquisition Specification on the Single Loop BW Reference Scheme

	Freq. Offset (kHz)	Acq. Time (MS)	Loop Nat. Freq. (kHz)	Baseline Degradation (dB)
Alternative 1	80	4	50	0.5
	80	7	40	0.3
	80	18	30	0.25
	80	32	25	0.2
	80	60	20	0.1
	80	320	14	0.1
Alternative 2	40	1	63	0.6
	30	1	52	0.5
	20	1	40	0.3
	10	1	25	0.2
Alternative 3	40	32	20	0.15
	30	32	16	0.1
	20	32	13	~ 0
	10	32	8	0
	20	20	14	~0.1

2.3.2.3 Dual B/Hz Capability

A relatively simple technique was uncovered during the study phase for providing 1 B/Hz as well as 2 B/Hz capability in the modem. The technique exploits maximal equipment commonality between the two modes of operation in both modulator and demodulator. The technique allows 13.41 Mb/s operation in the 1 B/Hz mode and 26.82 Mb/s operation in the 2 B/Hz mode - both operating in an authorized bandwidth of 14 MHz.

The approach involves using mod-index 1/4 4-ary FSK in the 1 B/Hz mode and mod-index 1/8 4-ary FSK in the 2 B/Hz mode. At the modulator, operation as described above results in both modes utilizing the same four modulation frequencies. The 1 B/Hz mode simply selects one of the four synthesized frequencies at one-half the rate (6.705 MHz) as the 2 B/Hz mode (13.41 MHz). Thus, the modulator is common between the two modes.

Figure 32 shows the manner in which the two modes are handled at the demodulator. In the 2 B/Hz mode the 70 MHz radio IF signal is filtered by a 13.41 MHz (symbol rate) 3 dB bandwidth filter and passed directly on to

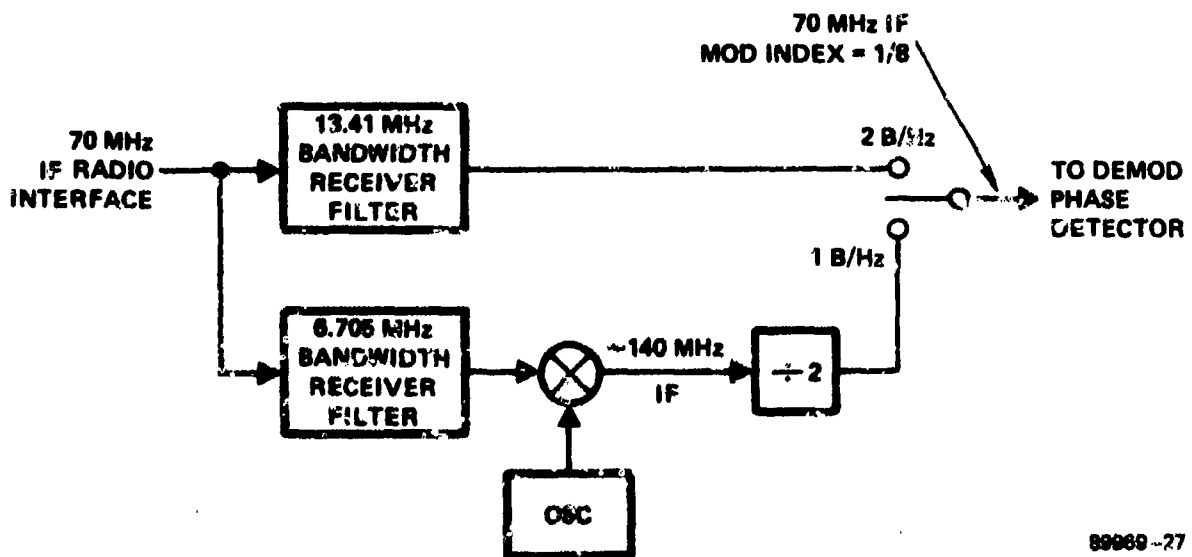

Figure 32. Dual B/Hz Conversion Demodulator Front-End

the demodulator phase detector and A/D which is designed under the assumption of mod-index 1/8 4-ary FSK input (the ideal phase nodes are spaced by 45°). In the 1 B/Hz mode on the other hand a conversion step is included as shown to convert the received mod-index 1/4 signal to mod-index 1/8 after filtering by a 6.705 MHz (again, symbol rate for this mode) 3 dB bandwidth IF filter. This conversion is accomplished by first mixing to a nominal 140 MHz IF frequency followed by frequency divide-by-2 to produce a nominal 70 MHz mod-index 1/8 IF signal which once again is appropriate to feed to the phase detector and A/D for further processing. Fortunately, the signal phase distortion produced by the 6.705 MHz bandwidth filter in the 1 B/Hz mode is almost exactly twice that in the 2 B/Hz mode. As a result, after the frequency divide-by-2 operation (+2 counter) the signal phase distortion is identical between the two modes. Further, this means that the phase quantizing thresholds in the phase detector are identical between the two modes. Thus, the only differences in the demodulator required between the modes are the changes required to handle the two different symbol rates (reference loop bandwidth change and symbol timing loop change).

The approximate 6 dB improvement in performance of the 1 B/Hz mode over the 2 B/Hz mode can be thought of in light of this conversion step in the following way. The ideal phase node spacing of the converted signals are identical (45°) for the two modes. Because of the divide-by-2 operation in the 1 B/Hz mode, however, the rms noise-caused phase jitter is halved. This is the source of the 6 dB improved performance.

2.3.2.4 New Receiver IF Filter

During this study it was found that a 4-pole Butterworth filter with two sections of all-pass phase compensation performed better than the prior modem's 4-pole Bessel filter. The 3 dB bandwidth is equal to the 4-ary symbol rate. The attenuation and group delay distortion characteristics of this filter are shown in Figure 33.

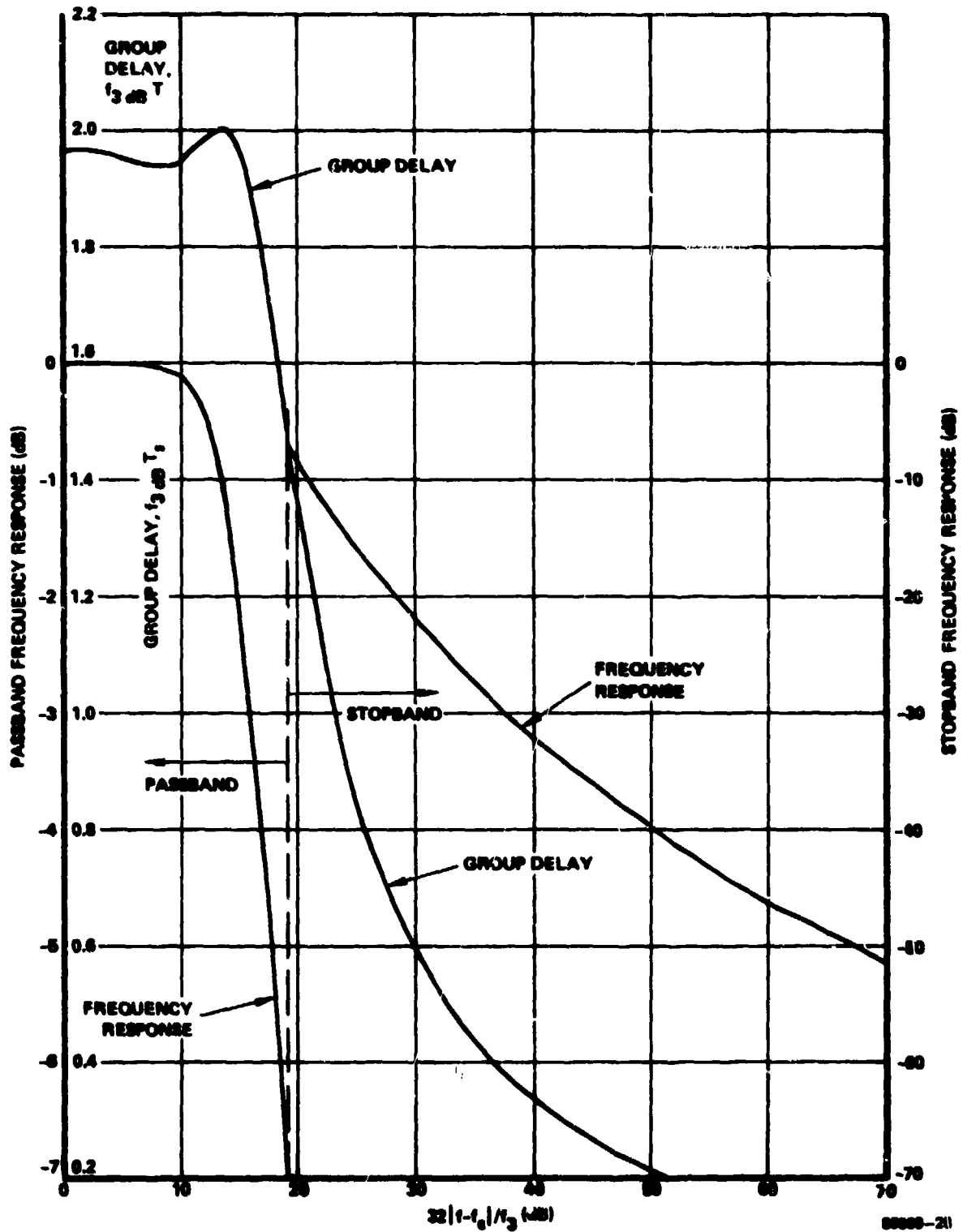

Figure 33. RCVR Filter Characteristics

SECTION 3.0
HARDWARE DESCRIPTION

3.0 HARDWARE DESCRIPTION

An experimental modem incorporating the baseline concepts described in Section 2.0 was constructed. The actual hardware is described in this section. The modulator and demodulator sections of the modem are physically packaged separately.

3.1 Modulator

The modulator is contained in a 5.25 inch high chassis designed to be mounted in a standard 19-inch rack. The unit contains integral power supplies and cooling fan. It should be noted that as cooling air is drawn into the chassis from the top, a minimum space of 3.5 inches is required above the unit.

A photograph of the modulator front panel is shown in Figure 34. Input data is applied to jacks A and B.



Figure 34. Modulator Front Panel

For 2 B/Hz, 26.82 Mb/s single stream operation and 1 B/Hz, 13.41 Mb/s single stream operation, channel A is used exclusively. For 2 B/Hz and two synchronous 13.41 Mb/s stream operation, channels A and B are multiplexed together within the modulator producing a single internal 26.82 Mb/s data stream. An input bit rate clock, synchronous with the input data must be applied to the INPUT CLOCK jack. The data transition should occur on the rising edge of the clock. Exact alignment is not required, but

timing should be within 1/4 bit time. A transmit clock is provided at the OUTPUT CLOCK jack. Its frequency is crystal-controlled and automatically switches from 26.82 MHz to 13.41 MHz as required when the MODE switch is operated. The three most counterclockwise positions of the MODE switch are for 2 B/Hz operation. Position A is for use with a single 26.82 Mb/s data stream (applied to jack A). Position A+B is for multiplexing two 13.41 Mb/s data streams together (jacks A and B). The position labeled TEST reconfigures the internal 20-stage randomizer for use as a pseudorandom sequence generator. No external data or clocks need be applied in this mode. The two most clockwise positions of the MODE switch are used for 1 B/Hz operation. Position A is for a single 13.41 Mb/s input data stream (jack A). There are no multiplexing provisions in the 1 B/Hz mode. The 1 B/Hz TEST position allows for internal generation of a 13.41 Mb/s pseudorandom data stream. The IF OUTPUT jack provides a modulated 70 MHz signal at a nominal level of +1 dBm.

All front panel jacks are BNC type and are designed to interface with 75 ohm circuits. Digital input and output levels are nominally 2 volts peak-to-peak with +1 volt being a "1" and -1 volt a "0".

A conceptual block diagram of the Modulator is shown in Figure 35. Its theory of operation is identical to that of the previous modem where pairs of data bits are used to select one of four phase coherent frequencies each symbol time. The four tones are generated by mixing an 8 times bit rate clock with bit rate and symbol rate. This forms a mod-index 1 signal which is divided by 8 to generate the desired mod-index 1/8 signal which is mixed up to 70 MHz. The primary difference between this modulator and the previous one is the phase-locked loop (PLL) that locks to the externally supplied bit rate clock. This PLL supplies all the modulator clocks, including the 8 times bit rate clock used in the frequency generator. Thus, the four tones have a fixed time relationship to the symbol rate clock that selects the desired tone.

Input data is applied to lines A and B. For 2 B/Hz single stream operation and 1 B/Hz operation, channel A is used exclusively. For 2 B/Hz and two synchronous 13.41 Mb/s stream operation, channels A and B are fed to the MUX where a single 26.82 Mb/s stream is produced. This

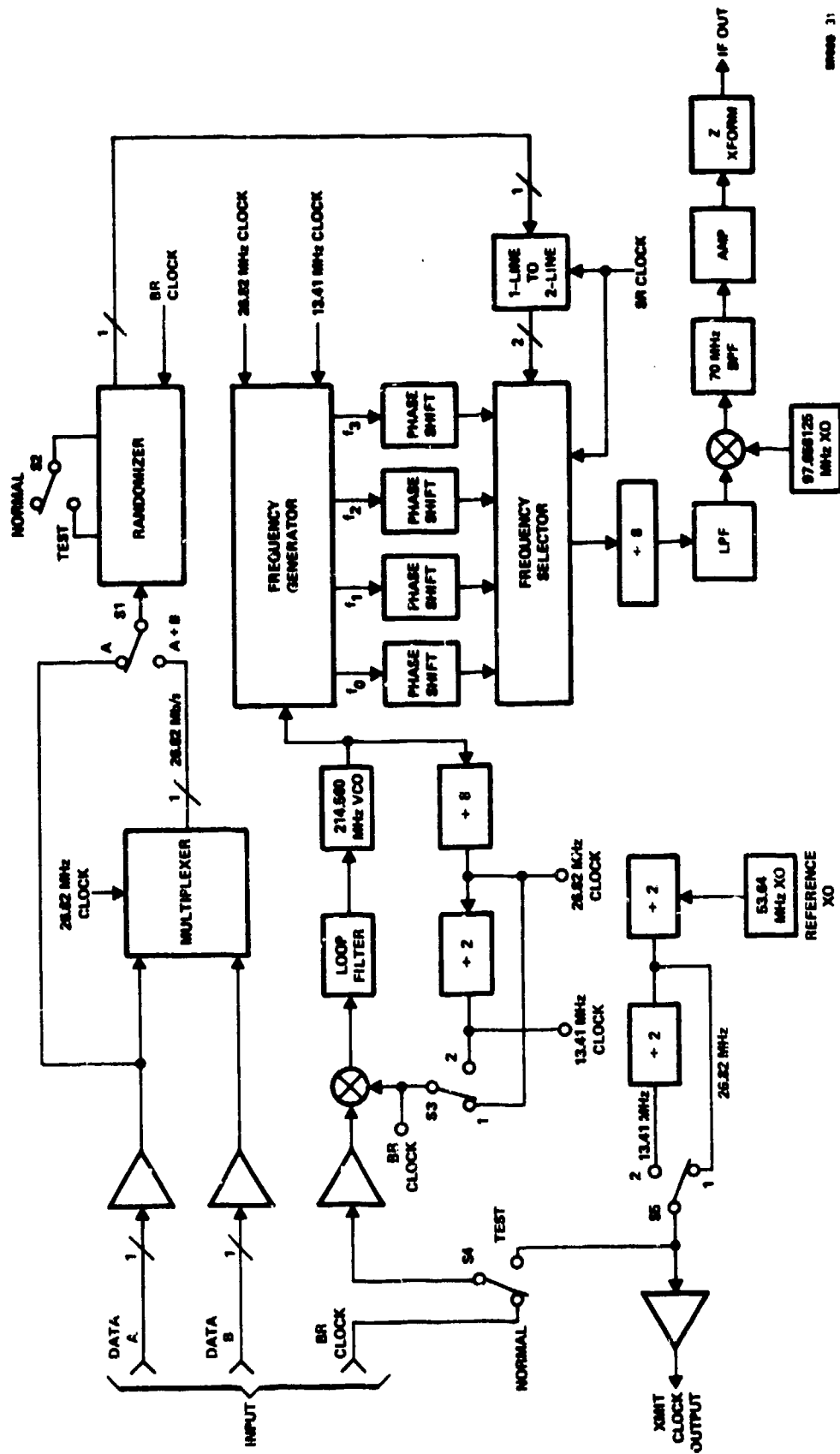

page 31

Figure 35. Modulator Block Diagram

stream is randomized and fed to the Frequency Selector. In the test mode, the randomizer is used to produce a pseudorandom sequence and requires only a clock input. For this mode, the clock PLL locks to an internal reference clock which also supplies a transmit clock to the outside world.

One B/Hz operation is provided by selecting the tones (which remain the same) at one half the 2 B/Hz symbol rate, producing a mod-index 1/4 signal.

3.2 Demodulator

The demodulator is contained in an 8.75-inch high chassis designed to fit a standard 19-inch rack. The unit contains integral power supplies and cooling fan. As cooling air is drawn into the top of the chassis, a minimum space of 3.5 inches above the unit is required.

A photograph of the demodulator front panel is shown in Figure 36. The demodulator receives IF at 70 MHz, +1 dBm at the IF IN jack.



Figure 36. Demodulator Front Panel

Input impedance is 75 ohms. Output data appears at jacks A and B. Recovered bit rate timing appears at the CLOCK OUTPUT jack. The data transitions occur on the rising edge of this clock. In the self-test mode (selected at the modulator) bit errors detected by the internal self-synchronizing derandomizer produce positive pulses on the BIT ERROR OUTPUT jack. Normally, this output remains at a logic "0" (-1.0 V into 75 ohms) when the modem is operating error-free in the TEST mode. All logic outputs provide 2 volts peak-to-peak into a 75 ohm load. A logic "1" is represented by +1.0 volt and a logic "0" by -1.0 volt.

The MODE switch has three positions. The two most counterclockwise positions select 2 B/Hz operation. Position A is used when the modulator receives a single 26.82 Mb/s data stream. This position is also used for the 2 B/Hz TEST mode (selected at the modulator). Position A+B corresponds to the similarly marked position on the modulator when the data input consists of two synchronous 13.41 Mb/s data streams. The single 1 B/Hz position, A, is used for both 13.41 Mb/s data stream operation and the 1 B/Hz TEST mode. With the demodulator MODE switch set to the position corresponding to that chosen on the modulator, the output data appearing at jacks A and B corresponds to the input data at the input jacks on the modulator bearing the same label.

With the modulator in one of the two TEST modes, the data outputs on the demodulator will remain at a logic "1" when the modem is operating error-free. The BIT ERROR OUTPUT produces a half-bit period pulse for each error detected. Bit error rate performance can be determined by measuring the frequency at the BIT ERROR OUTPUT jack and dividing this number by the bit rate (26.82 Mb/s or 13.41 Mb/s). The derandomizer is of such a design that it will produce three pulses for every isolated error made by the processing logic. This corresponds to normal operation when the randomizer/derandomizer introduces an approximate factor of three degradation in bit error rate performance.

A conceptual block diagram of the Demodulator is shown in Figure 37. In 2 B/Hz mode, the 70 MHz IF is fed to a linear phase, matched filter and then to a limiter. In 1 B/Hz operation, the mod-index 1/4 signal is fed to another matched filter and is then mixed up to approximately twice

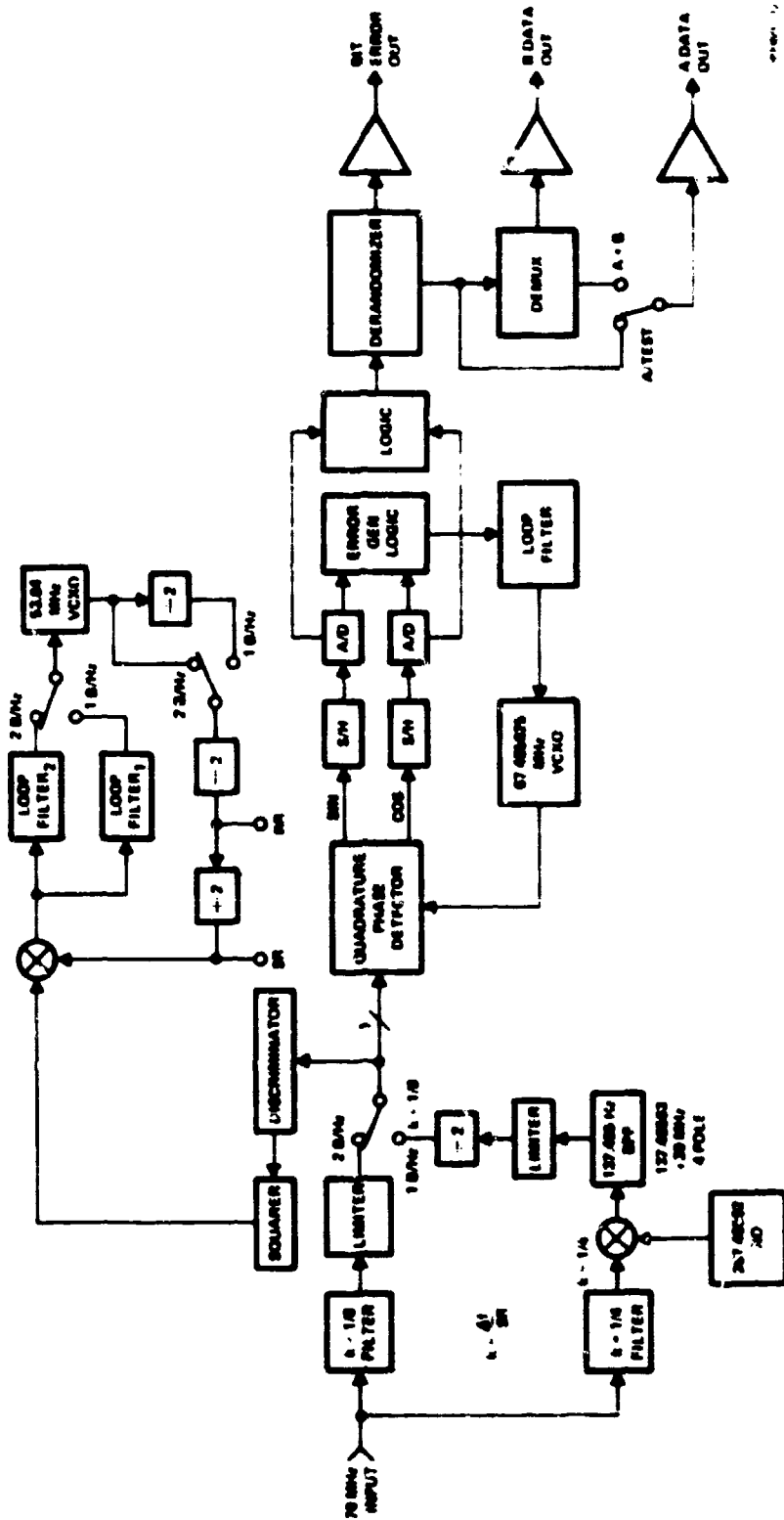

Figure 37. Demodulator Block Diagram

the center frequency and then divided by two to produce a mod-index 1/8 signal. It is then processed the same as the 2 B/Hz signal.

The limited signal is applied to the quadrature phase detector. The phase measurements of the sine and cosine channels are sampled and held while their values are digitized by the A/D's. Logic circuitry is used to derive an error signal from the phase measurements. This error signal is used to drive a VCXO through the loop filter. The VCXO provides the reference for the phase detector. The loop closure thus aligns the reference to minimize the average error to the phase modes. The A/D outputs also go to the processing logic. This logic is identical in concept to that used in the breadboard developed on the previous contract (F39602-74-C-0263). For a detailed explanation of its operation, refer to Final Technical Report RADC-TR-76-117. The recovered data from the logic goes to the self-synchronizing derandomizer. The derandomized data is fed to the demux which can be bypassed for single stream operation.

Demod timing is recovered by a discriminator on the limited input signal producing a PAM sequence. Squaring recovers the symbol rate component to which a PLL is locked, providing symbol rate and bit rate clocks for the demodulator.

3.3 FCC 19311 Waveguide Filter

In order to meet the spectral requirements of FCC Docket 19311, a microwave filtering approach was used. The filter is a waveguide section designed to be installed directly into the LC8D radio, replacing the final transmitter output filter.

The desired filter characteristics were specified as follows:

Electrical Characteristic Desired:

- 1) Attenuation and group delay characteristics associated with a 4-pole Butterworth filter. (See Figures 15 through 18 for detail)
- 2) 3 dB bandwidth = 16 MHz

- 3) Center frequency at room temperature (25° C) = 8.075 GHz
- 4) Detuning versus temperature: Center frequency shift < ± 450 kHz over 0° to 50° C temperature
- 5) Insertion loss: < 1 dB
- 6) Max. VSWR: 1.1
- 7) Critical attenuations required: At room temperature (25° C) at 8.075 GHz ± 13.41 MHz filter must be 19 dB down

Mechanical Characteristics

1. Waveguide size: WR112
2. Dimensional information:
 - a) Flange-to-flange: 7" in-line
 - b) Max., dimension at right angle: 4" (oneside only)
3. Flange type: UG-51 for WR112 waveguide

The filter was manufactured by MDL. The specifications were treated as design goals. The filter delivered to Harris ESD failed to meet the desired group delay distortion characteristics. The actual filter's group delay distortion is shown in Figure 38. The excessive group delay peaks near the band edges account for much of the excess degradation introduced by the filter. It was determined that group delay compensation introduced at IF should be investigated during the test program at RADC.

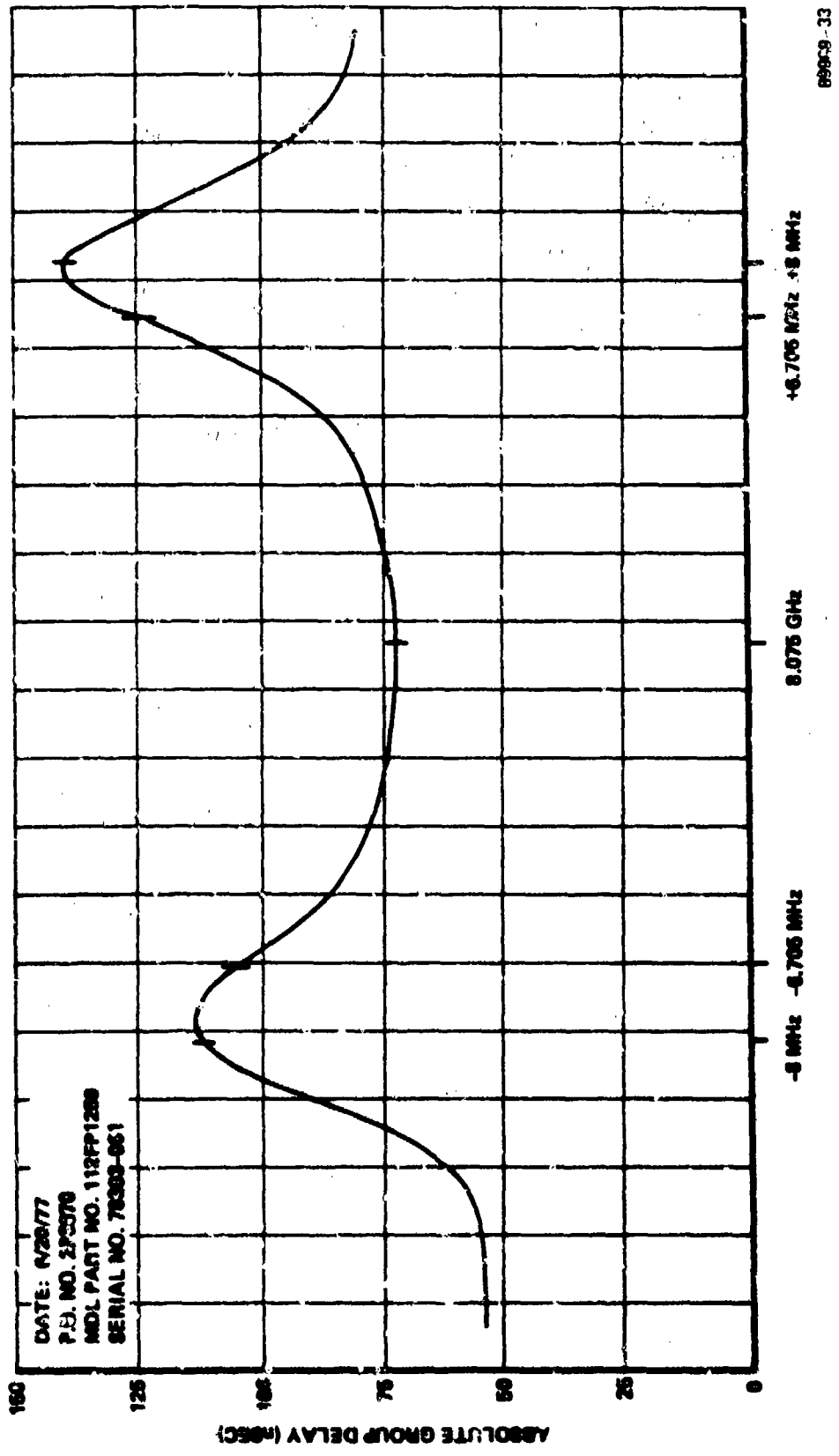

Figure 38. Group Delay Distortion 4-Pole Butterworth Waveguide Filter

SECTION 4.0

TEST RESULTS

4.0 TEST RESULTS

The test program was performed at Harris ESD in Melbourne, Florida, and at RADC in Rome, New York. The in-plant tests were designed to provide a performance baseline from which to interpret results from later radio tests and to verify the characteristics of various internal parameters. These tests were performed with the modem looped back at 70 MHz with additive thermal noise. Tests were also performed with the modem looped back through an up/downconverter allowing the introduction of the FCC 19311 waveguide filter to the signal path. The RADC tests included back-to-back tests at 70 MHz and tests through the LC8D radio connected back-to-back. The test plan which describes test setups and procedures is included in this report as Appendix C.

In this section, the test results are presented. Modem performance was very good and all design requirements were met. In addition the modem performance came very close to meeting all design objectives.

4.1 In-Plant Tests

This paragraph presents data acquired at Harris ESD during the period of November 1, 1977 through November 4, 1977.

4.1.1 Spectral Efficiency Results

Since the actual spectrum presented at the radio transmitter output is the true measure of compliance with FCC Docket 19311, tests performed at Harris ESD could only be useful as preliminary indicators. Hence, detailed plots were taken only at RADC. However, photographs were taken at Harris ESD of the spectra at 70 MHz at the Modulator output and at the output of the up/down converter that contained the FCC 19311 waveguide filter. Figure 39 shows the 2 B/Hz spectrum directly at the modulator output. Figure 40 shows the 2 B/Hz spectrum after the waveguide filter and down-conversion to 70 MHz. Examination of these spectra indicated that the

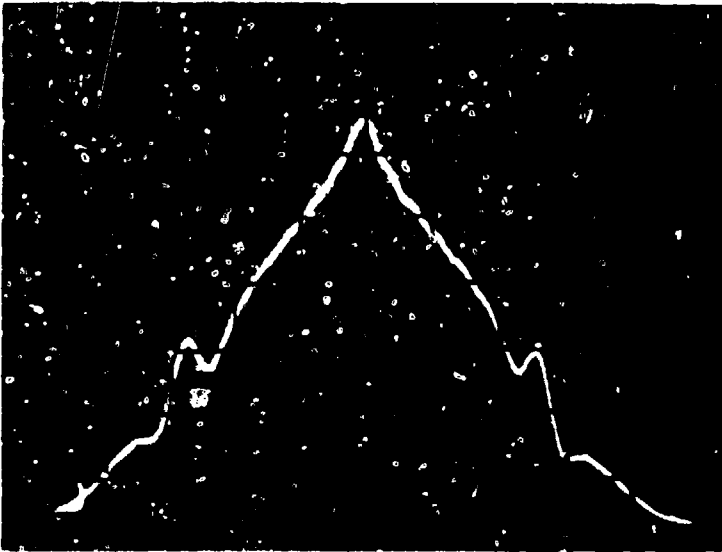

BIF = 300 kHz
 $B_V = 100$ Hz
 VERTICAL - 10 dB/DIV
 0 dB = TOTAL
 POWER
 HORIZONTAL - 5 MHz/DIV
 11/1/77

Figure 39. 2 B/Hz Spectrum Without FCC 19311 Filter



BIF = 300 kHz
 $B_V = 100$ Hz
 VERTICAL - 10 dB/DIV
 0 dB = TOTAL
 POWER
 HORIZONTAL - 5 MHz/DIV
 11/1/77

Figure 40. 2 B/Hz Spectrum With FCC 19311 Filter

filter performed as expected and that the requirements of FCC 19311 would be met.

The 1 B/Hz spectrum before and after filtering is shown in Figures 41 and 42 respectively. Compliance with FCC Docket 19311 was also indicated here.

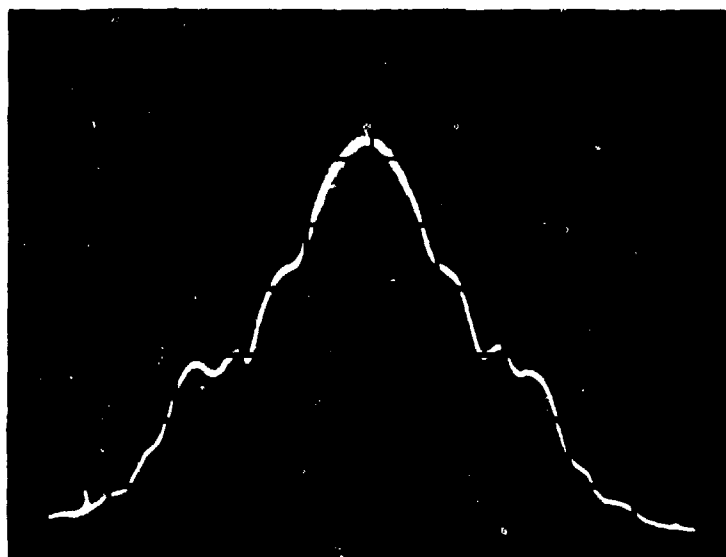

BIF = 300 kHz
B_v = 100 Hz
VERTICAL - 10 dB/DIV
0 dB = TOTAL
POWER
HORIZONTAL - 5 MHz/DIV
11/1/77

Figure 41. 1 B/Hz Spectrum Without FCC 19311 Filter

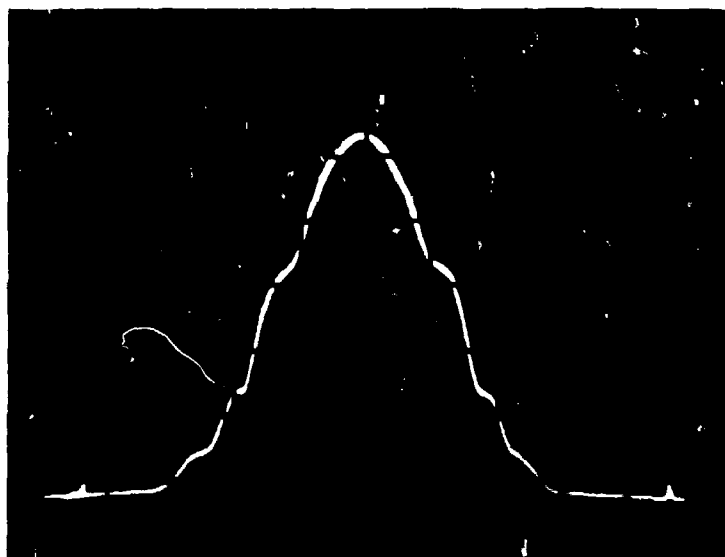

BIF = 300 kHz
B_v = 100 Hz
VERTICAL - 10 dB/DIV
0 dB = TOTAL
POWER
HORIZONTAL - 5 MHz/DIV
11/1/77

Figure 42. 1 B/Hz Spectrum With FCC 19311 Filter

More detailed and documented spectral results are presented in the RADC test result section.

4.1.2 BER Vs E_b/N_0

The design objective for the modem was a bit error rate of 5×10^{-9} or less at an E_b/N_0 of 22 dB when operating through the Philco Ford LC8D radio for a nominal 2 B/Hz spectral efficiency. The design objective for a nominal 1 B/Hz spectral efficiency under the same conditions was 5×10^{-9} bit error rate at an E_b/N_0 of 16 dB. These design goals are for performance without the 20 stage randomizer/derandomizer, which was not to degrade BER by more than a factor of 3 in the vicinity of a 1×10^{-7} BER. The BER was measured in a variety of configurations, as described below. Details of the test configuration and calibration are in Appendix C.

4.1.2.1 2 B/Hz Test Results

To obtain baseline performance data, the modulator and demodulator were connected directly at 70 MHz. Thermal noise with an equivalent bandwidth of 41.5 MHz was added at 70 MHz. Initially, the internal randomizer/derandomizer was bypassed and the plot shown in Figure 43 was obtained with an external data generator and error counter. The measured data is shown with a computer baseline prediction described in Section 2.0. In the vicinity of a 5×10^{-9} BER, the measured data is approximately 0.8 dB from that predicted. At higher bit error rates, the difference is closer to 0.5 dB. A BER of 5×10^{-9} was obtained at an E_b/N_0 of 20.6 dB back-to-back without randomizer.

Figure 44 shows 2 B/Hz back-to-back performance through the randomizer on Channel A with a single 26.82 Mb/s data stream. Comparison with Figure 43 shows that the randomizer introduced a BER degradation of less than a factor of three at any BER. Note that the computer-predicted curve has been shifted by a factor of three for all plots showing incorporation of the randomizer.

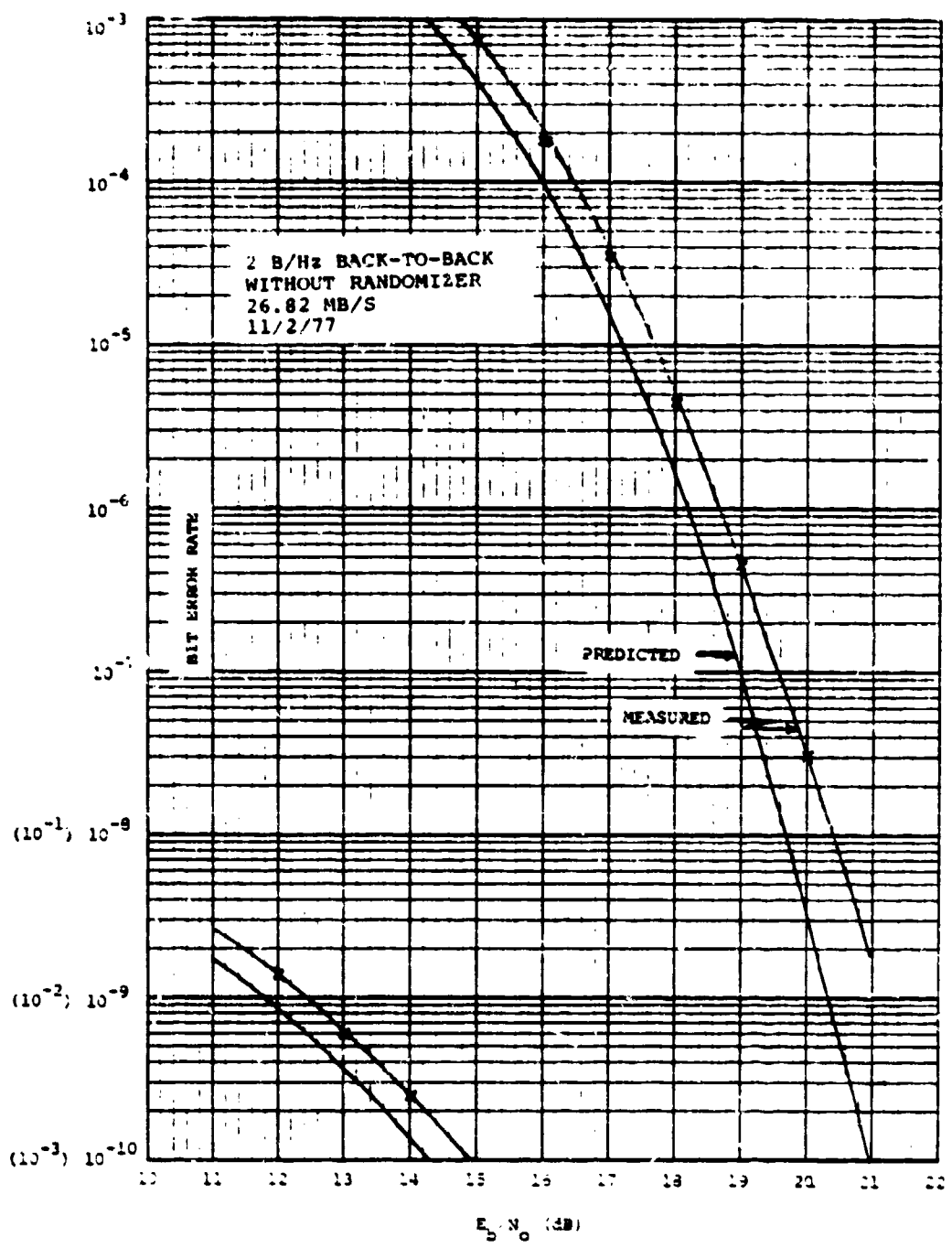

Figure 43. BER-2 B/Hz, Back-to-Back, Without Randomizer

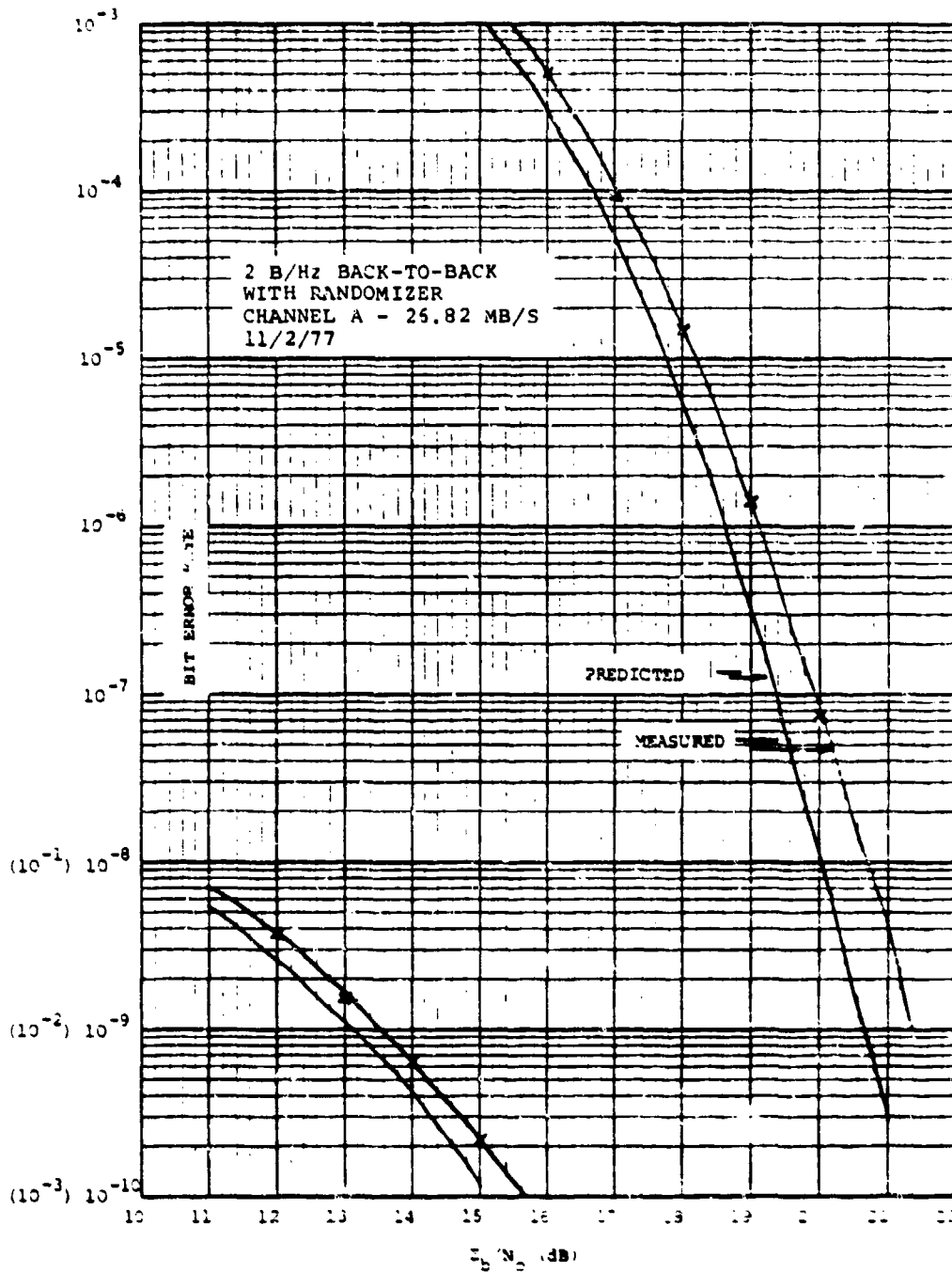

Figure 44. BER-2 B/Hz, Back-to-Back, With Randomizer
Channel A - 26.82 Mb/s

Figure 45 and Figure 46 demonstrate that performance in the A and B mode, where two synchronous 13.41 Mb/s data streams are multiplexed together, is essentially the same as that of the single 26.82 Mb/s data stream mode. Figure 47 shows performance as measured in the TEST MODE without benefit of external data generator and error detector. The resulting curve is virtually identical to that of Figure 44, demonstrating the validity of this test technique.

To simulate performance over the LC8D radio with FCC 19311 waveguide filter, the modulator output was upconverted to 8.075 GHz, filtered, and downconverted to 70 MHz where broadband noise was added. The results are shown in Figure 48. The randomizer was bypassed for this test to facilitate measurement. A BER of 5×10^{-9} was achieved at an E_b/N_0 of 22.9 dB. This is about 2.3 dB from the prediction and about 0.9 dB from the design goal. These results indicated that group delay compensation at 70 MHz might be desirable with the LC8D radio.

4.1.2.2 1 B/Hz Test Results

Figure 49 shows the basic 1 B/Hz BER performance without randomizer. A BER of 5×10^{-9} was achieved at an E_b/N_0 of 15.3 dB, which is approximately 1.3 dB from the predicted value. The same test run with randomizer resulted in a BER of 5×10^{-9} at an E_b/N_0 of 15.7 dB. This curve is shown in Figure 50. As with 2 B/Hz operation, performance is degraded by no more than a factor of three by the randomizer. BER performance was also measured using the internal TEST MODE. Results are within measurement error of those obtained with external BER measurement equipment. A plot of this data may be found in Figure 51.

The use of the FCC 19311 waveguide filter has much less effect on 1 B/Hz operation than 2 B/Hz operation. This is a result of the more compact 1 B/Hz spectrum. Figure 52 depicts 1 B/Hz BER performance without randomizer. A BER of 5×10^{-9} occurred at an E_b/N_0 of 15.6 dB. This exceeds the design goal by 0.4 dB. The computer simulation was 1.6 dB inside the measured value.

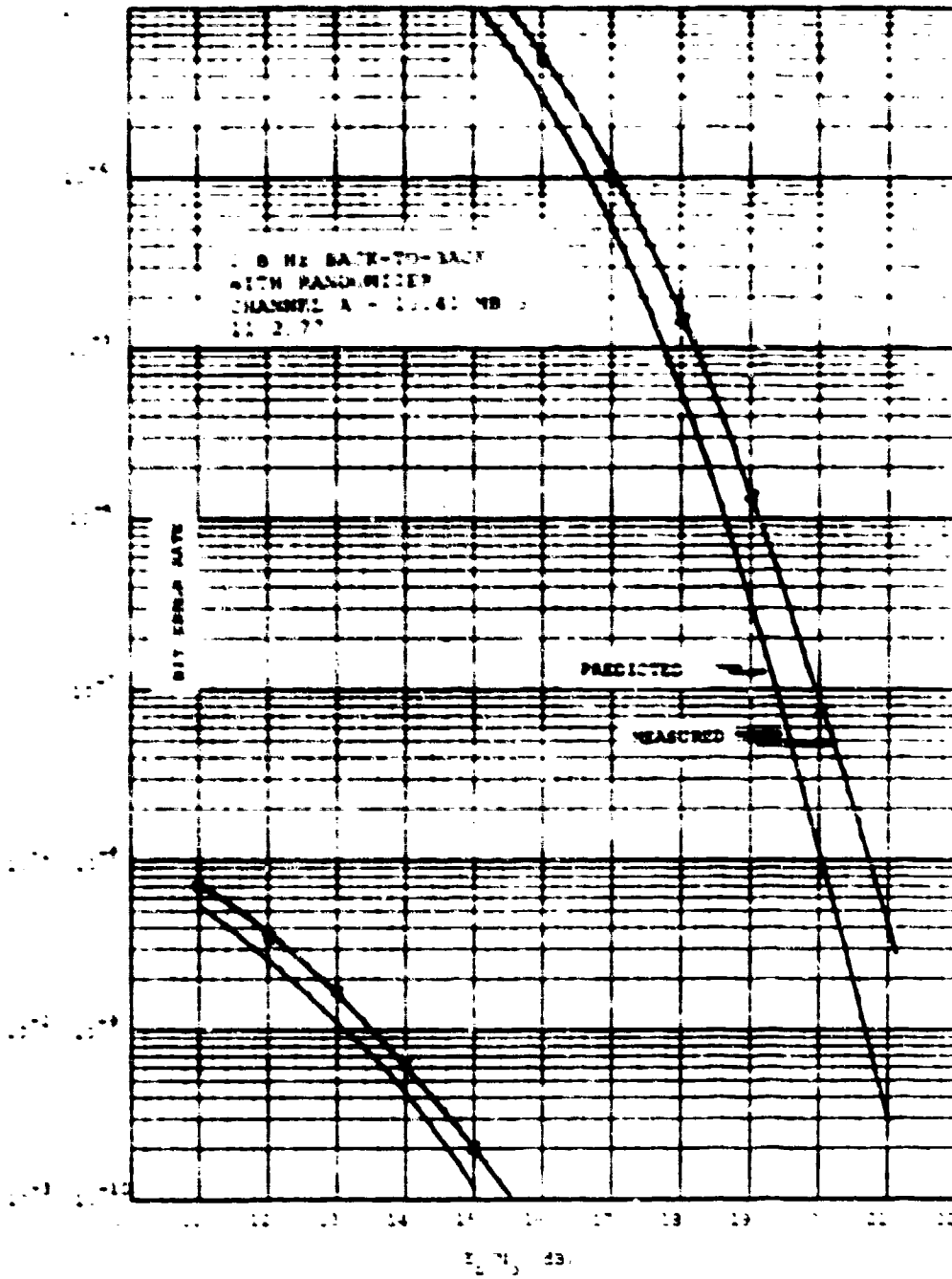

Figure 45. BER-2 B/Hz, Back-to-Back, With Randomizer
Channel A - 13.41 Mb/s

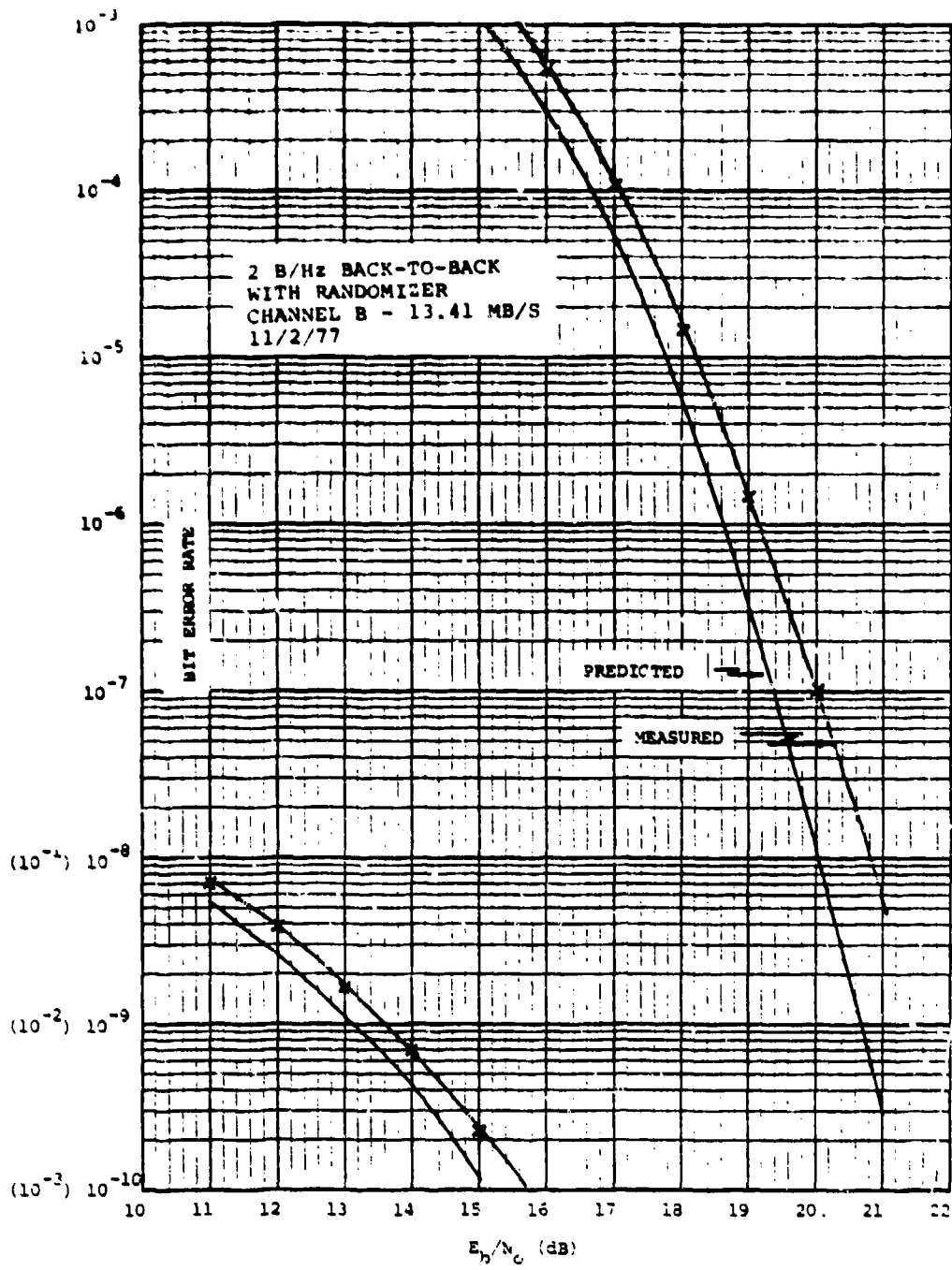

Figure 46. BER-2 B/Hz, Back-to-Back, With Randomizer
Channel B - 13.41 Mb/s

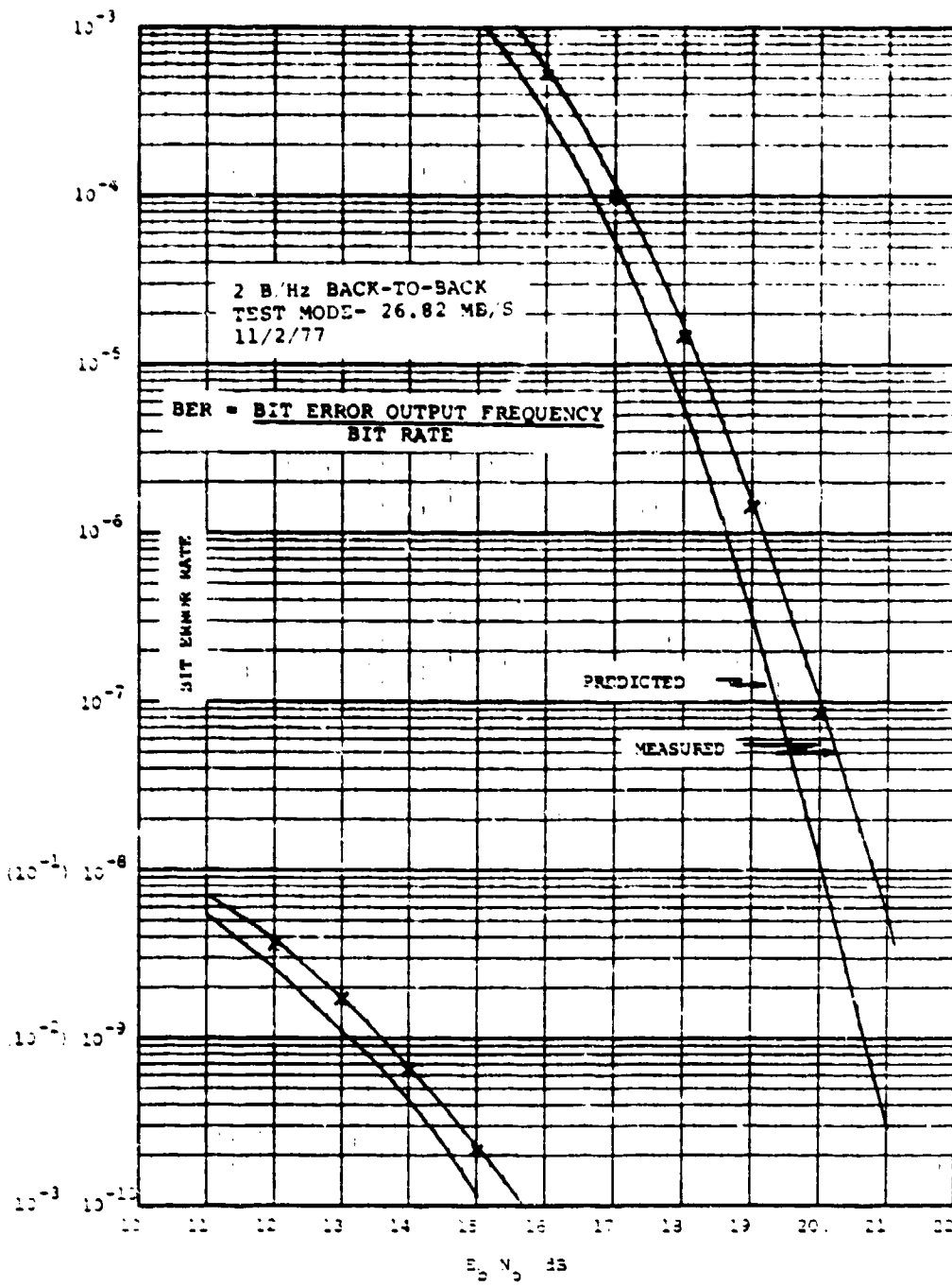

Figure 47. BER-2 B/Hz, Back-to-Back, Test Mode

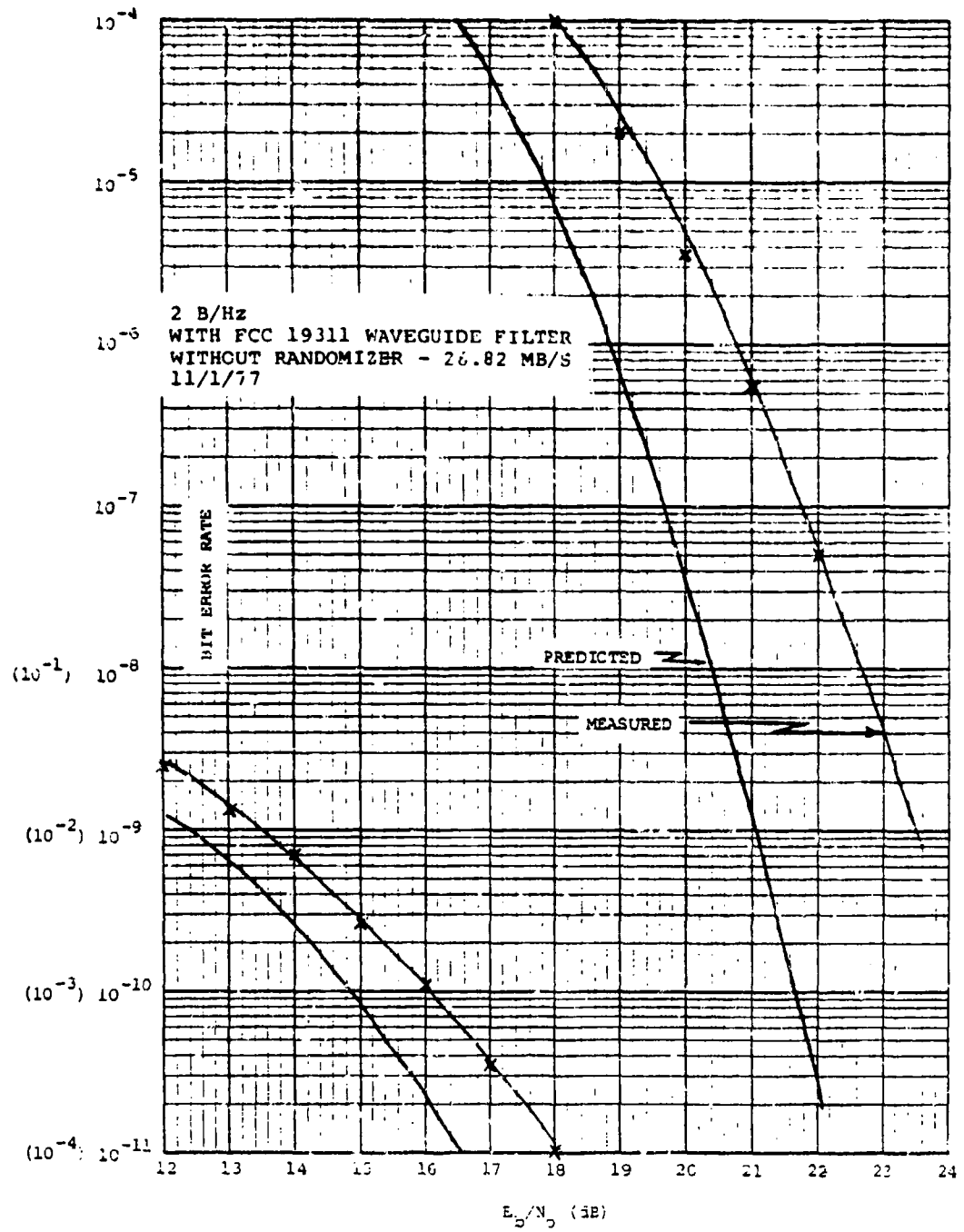

Figure 48. BER-2 B/Hz, With FCC 19311 Waveguide Filter, Without Randomizer

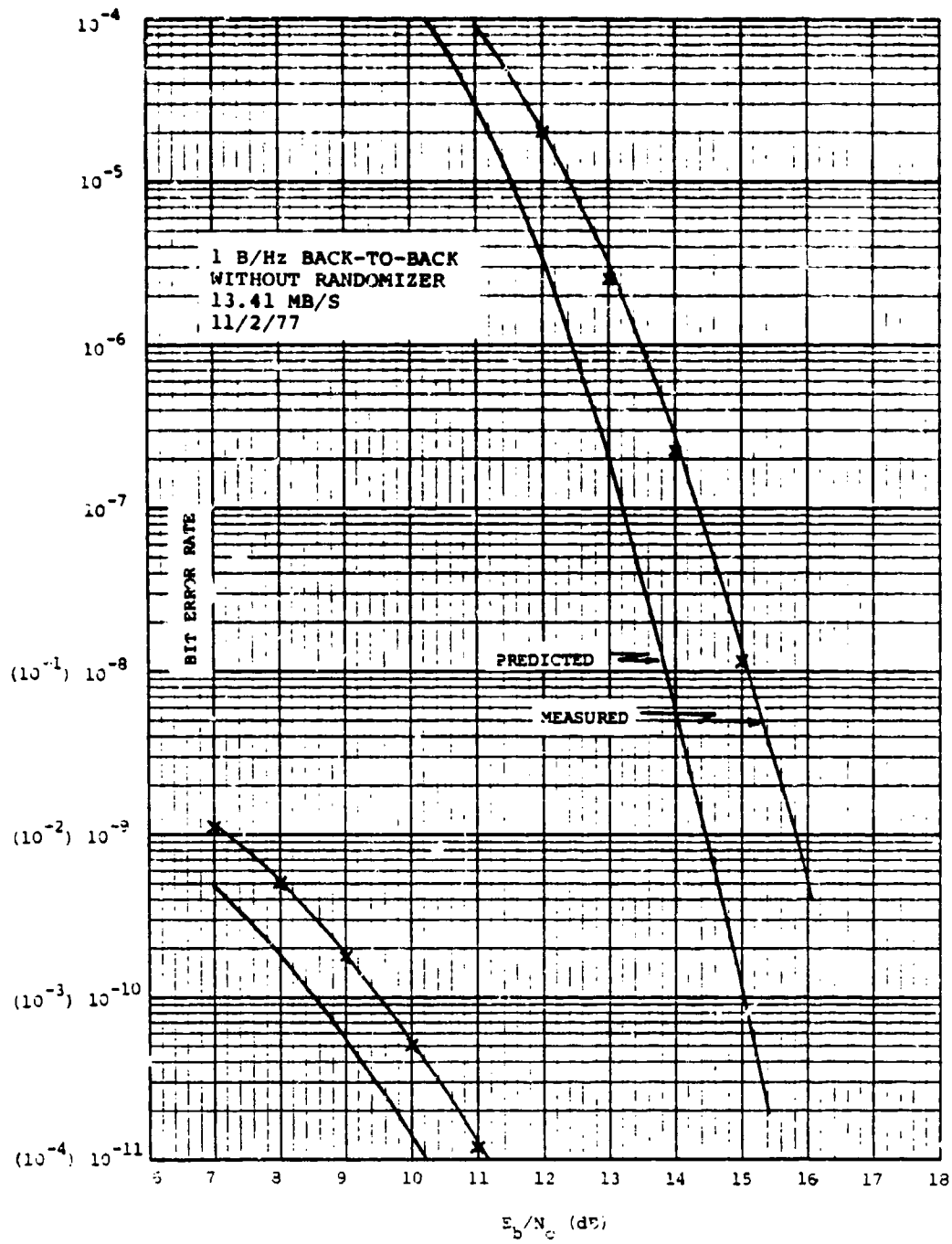

Figure 49. BER-1 B/Hz, Back-to-Back, Without Randomizer

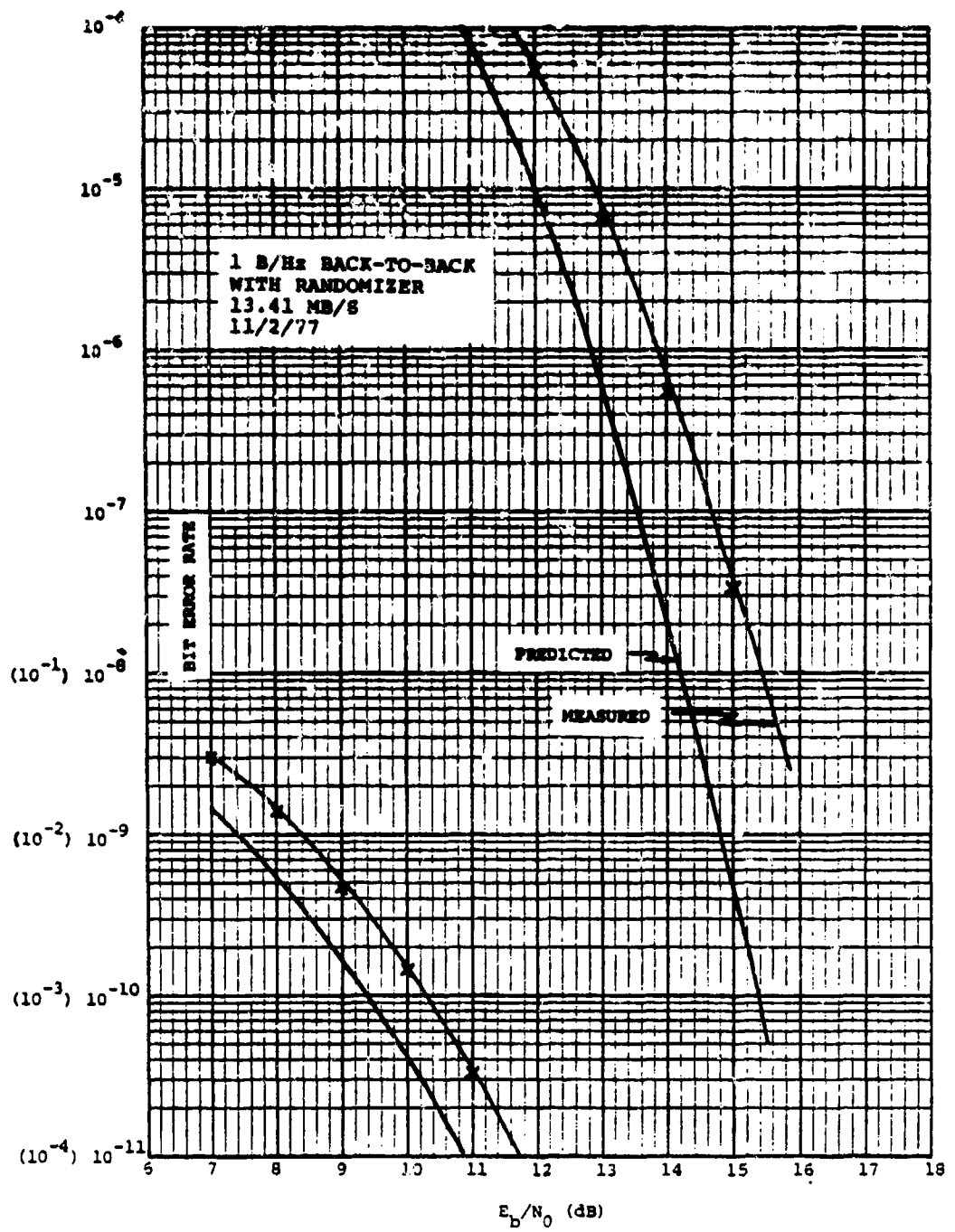

Figure 50. BER-1 B/Hz, Back-to-Back, With Randomizer

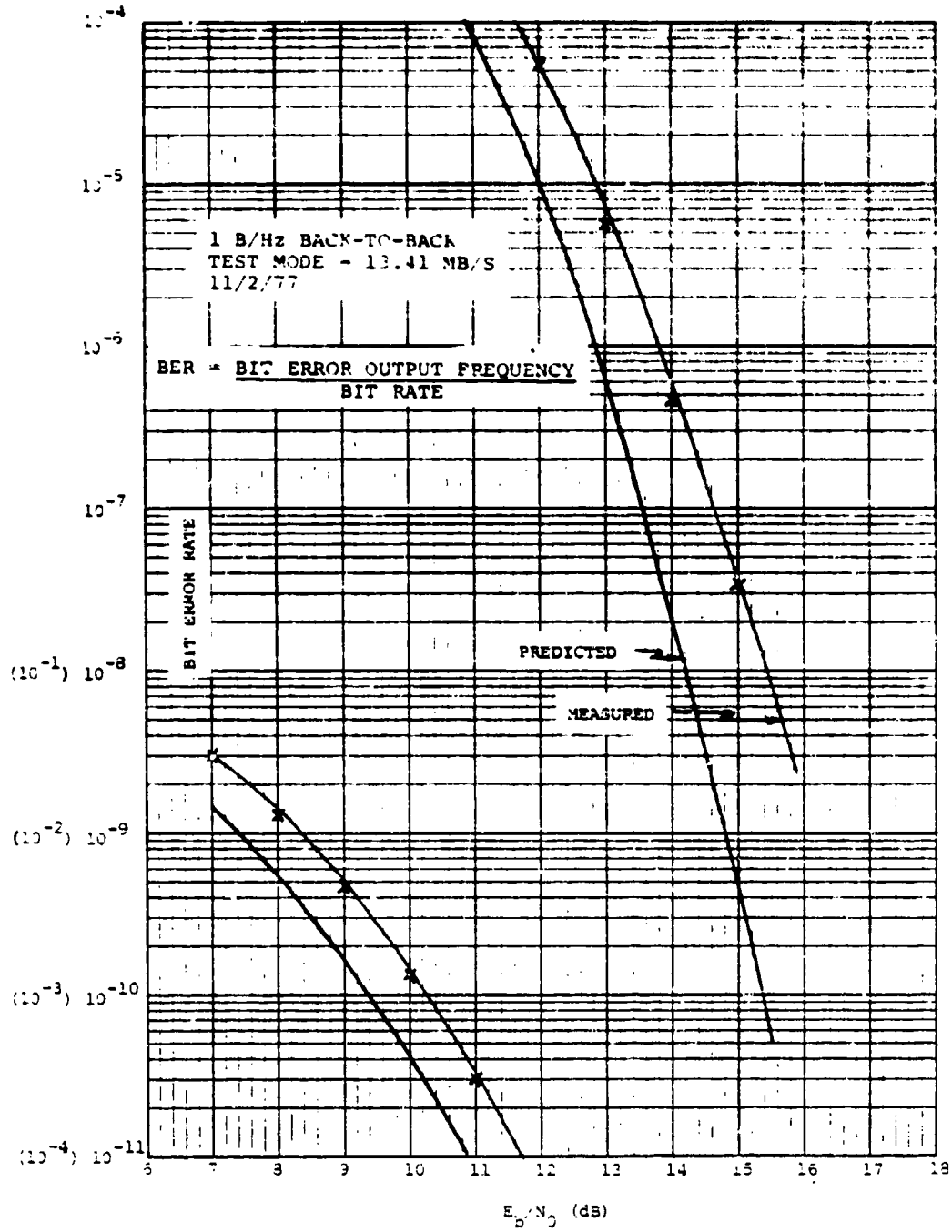

Figure 51. BER-1 B/Hz, Back-to-Back, Test Mode

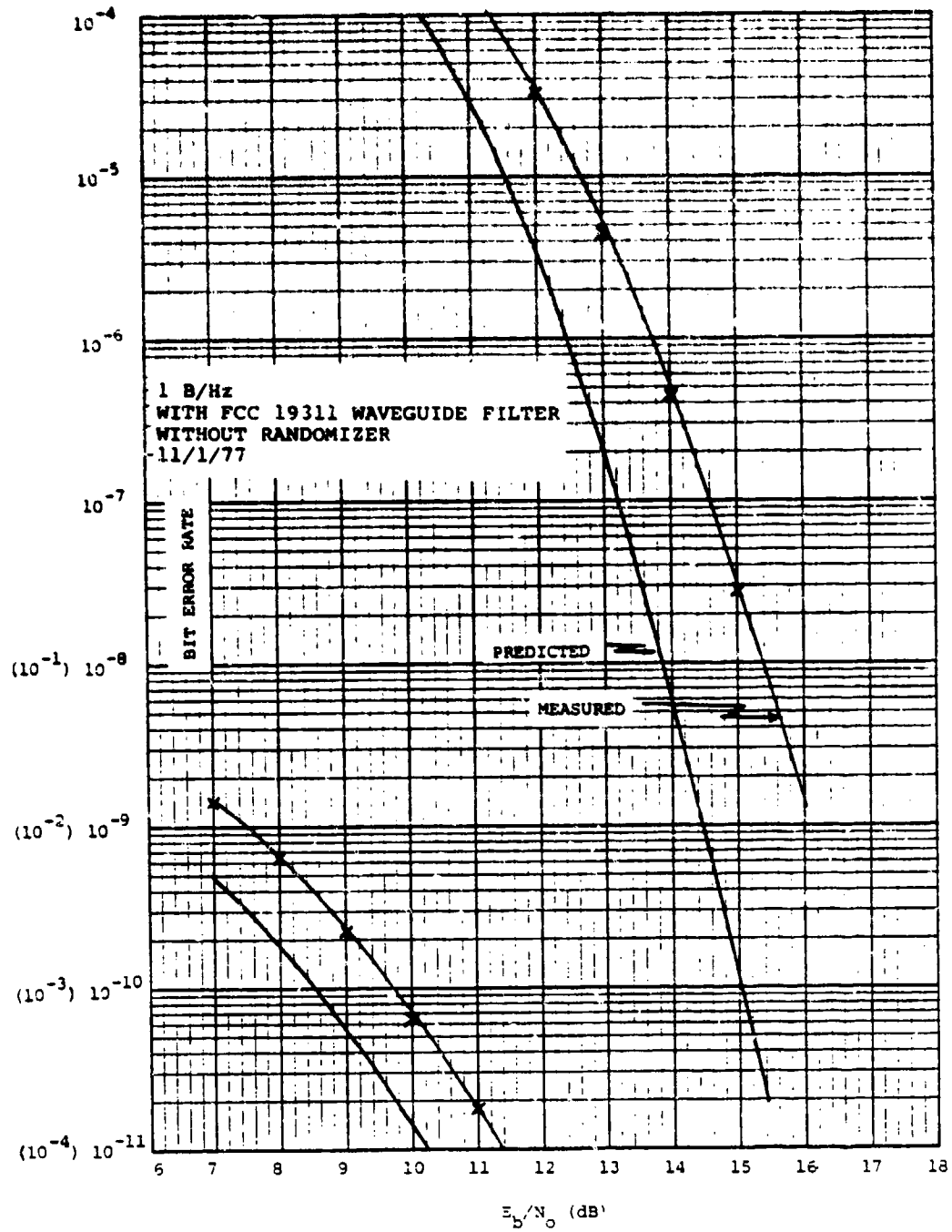
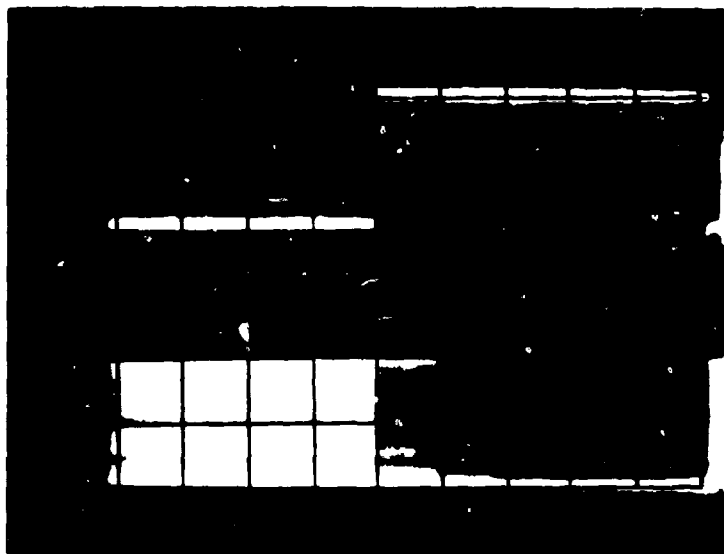

Figure 52. BER-1 B/Hz, With FCC 19311 Filter, Without Randomizer

4.1.3 Acquisition Test Results

Acquisition performance was tested by gating the IF signal on and off with an electronic switch. The modem was run in the self-test mode and the BIT ERROR OUTPUT observed on an oscilloscope. Noise was added to the IF to produce a BER in the vicinity of 1×10^{-7} with the demodulator locked up. With the IF gated off, a 50 per cent error rate produces a large number of transitions of the BIT ERROR OUTPUT. When the IF is reapplied and acquisition achieved, the error rate is so low as to make transitions unobservable on the oscilloscope. The transition from high error rate to low may be observed on the scope and compared to the time at which the IF is gated on. The photograph in Figure 53 was exposed long enough to record about 10 acquisition attempts. The modem was operating in the 2 B/Hz mode with an IF offset of +20 kHz. The upper trace marks the application of IF to the demodulator with a positive transition. The error transitions on the lower trace cease in less than 10 ms, indicating acquisition. Long term observation revealed that more than 90 percent of all acquisition attempts were completed in less than 10 ms and none were observed to require more than 20 ms. The design goal was 20 ms with an offset of 20 kHz. The same results were obtained for an offset of -20 kHz (Figure 54).

Acquisition in 1 B/Hz mode was measured with the same test set-up. Sample acquisitions are shown in Figure 55 and Figure 56 for +20 kHz offsets and -20 kHz offsets respectively. Acquisition was achieved successfully in less than 15 ms in more than 90 percent of all trials. On rare occasions (judged to be less than 1 percent of all trials) 25 ms was required for acquisition.



UPPER TRACE- POSITIVE
TRANSITION GATES IF ON

LOWER TRACE- BIT ERROR
OUTPUT, 5 ms/DIV

11/1/77

Figure 53. 2 B/Hz Acquisition, IF Offset +20 kHz

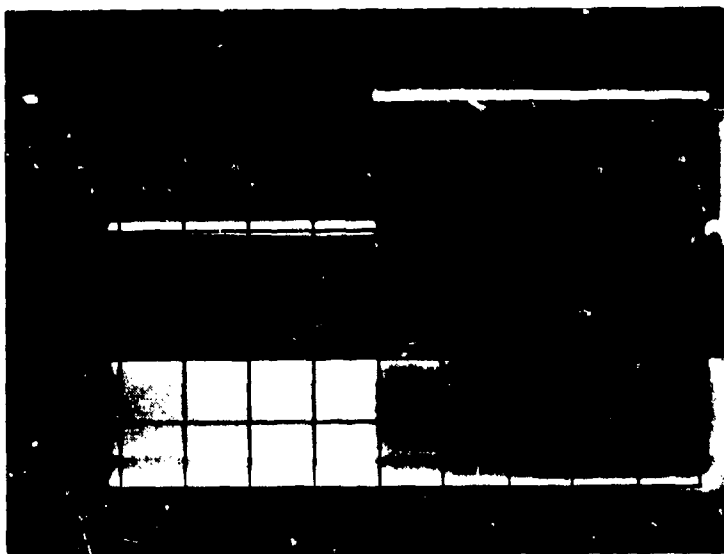

UPPER TRACE- POSITIVE
TRANSITION GATES IF ON

LOWER TRACE- BIT ERROR
OUTPUT, 5 ms/DIV

11/1/77

Figure 54. 2 B/Hz Acquisition, IF Offset -20 kHz

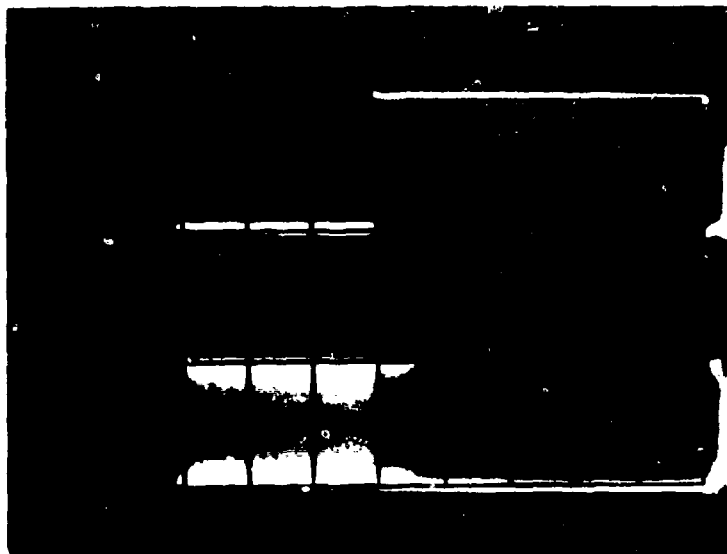

UPPER TRACE- POSITIVE
TRANSITION GATES IF ON

LOWER TRACE- BIT ERROR
OUTPUT, 5 ms/DIV

11/1/77

Figure 55. 1 B/Hz Acquisition, IF Offset +20 kHz

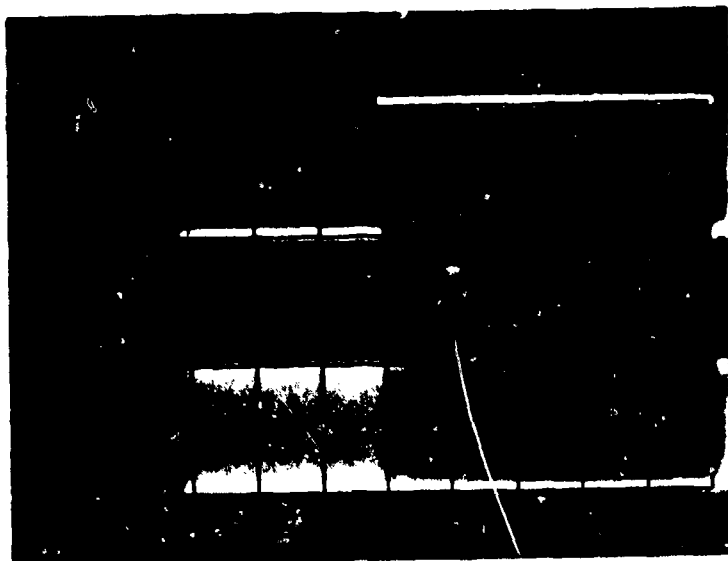

UPPER TRACE- POSITIVE
TRANSITION GATES IF ON

LOWER TRACE- BIT ERROR
OUTPUT, 5 ms/DIV

11/1/77

Figure 56. 1 B/Hz Acquisition, IF Offset -20 kHz

4.2 RADC Tests

This paragraph presents data acquired at the RADC test facility at Verona, New York, November 7, 1977 through November 11, 1977.

4.2.1 Spectral Efficiency Results

In order to demonstrate the spectral shaping introduced by the FCC 19311 waveguide filter, spectral measurements were first made at the output of the Philco Ford LC8D radio transmitter without the waveguide filter. The spectra were measured with a Hewlett Packard spectrum analyzer at 8 GHz. The analyzer was adjusted for 300 kHz IF bandwidth and 100 Hz video bandwidth and was used to drive an X-Y plotter. To ensure accuracy, the amplitude and frequency scales were calibrated with markers at 10 dB intervals on the vertical axis and with frequency markers at 0, +7, and +14 MHz on the horizontal axis. The 0 dB power reference was a single frequency tone from the modulator. This represents total transmitted power. All plots show a vertical axis that is corrected to a 4 kHz IF bandwidth. The correction factor for a bandwidth reduction from 300 kHz to 4 kHz is -18.8 dB, hence the nonintegral calibration marks.

Figure 57 shows the unfiltered 2 B/Hz spectrum at the transmitter output. The FCC 19311 spectral mask is drawn to scale on the plot. The two side lobes exceed allowable levels by some 12 dB indicating that additional filtering is required. Figure 58 shows the unfiltered 1 B/Hz spectrum. Its side lobes also exceed allowable levels by approximately 10 dB.

The spectra were remeasured after installation of the FCC 19311 waveguide filter at the radio transmitter output. Figure 59 and Figure 60 show the 2 B/Hz spectrum and 1 B/Hz spectrum respectively. The 2 B/Hz spectrum fits within the spectral mask with a minimum margin of approximately 4.4 dB. The 1 B/Hz spectrum has a margin of approximately 7.5 dB. Thus, the spectral requirements of FCC Docket 19311 are met.

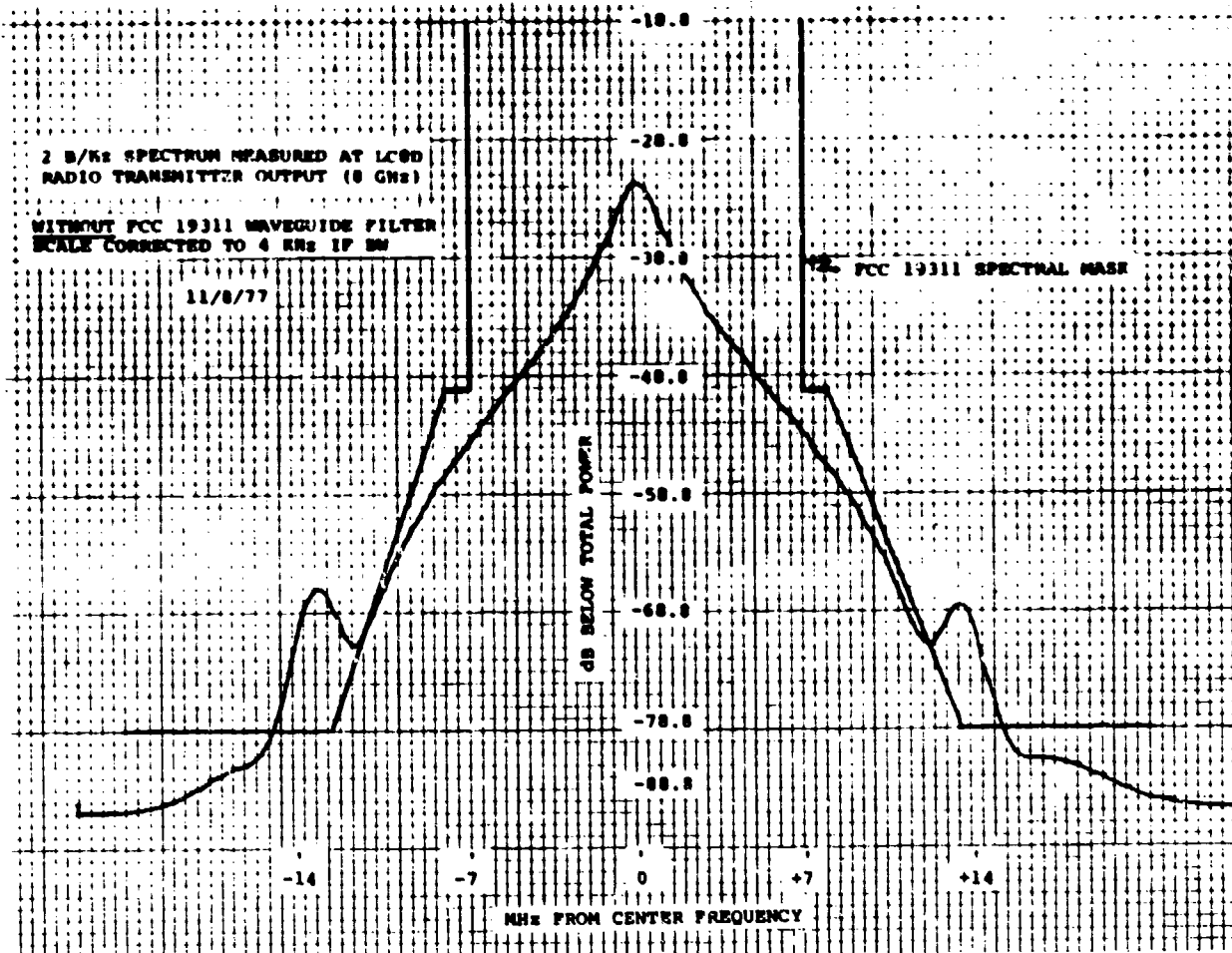

Figure 57. 2 B/Hz Spectrum Measured at LC8D Radio Transmitter Output (8 GHz) Without FCC 19311 Waveguide Filter

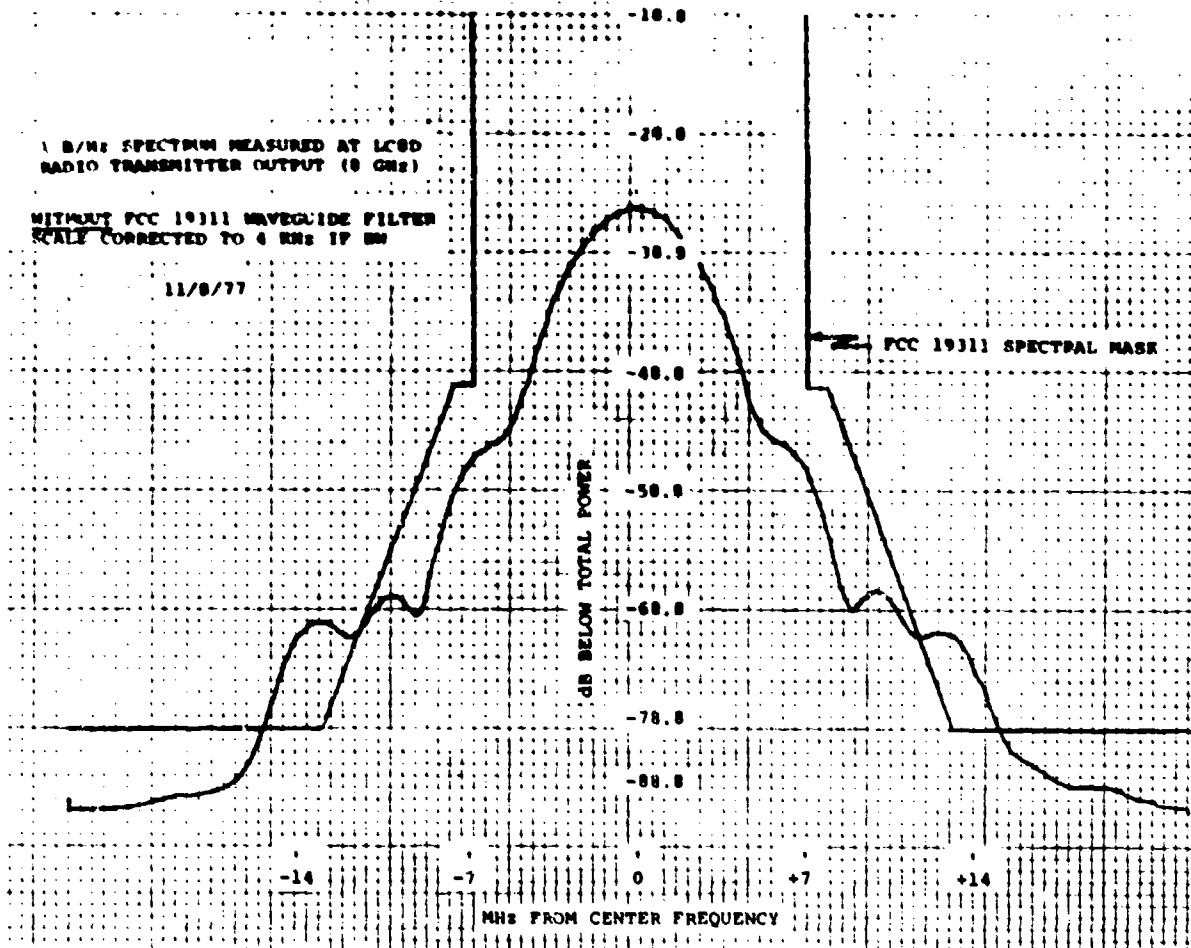

Figure 58. 1 B/Hz Spectrum Measured at LC8D Radio Transmitter Output (8 GHz) Without FCC 19311 Waveguide Filter

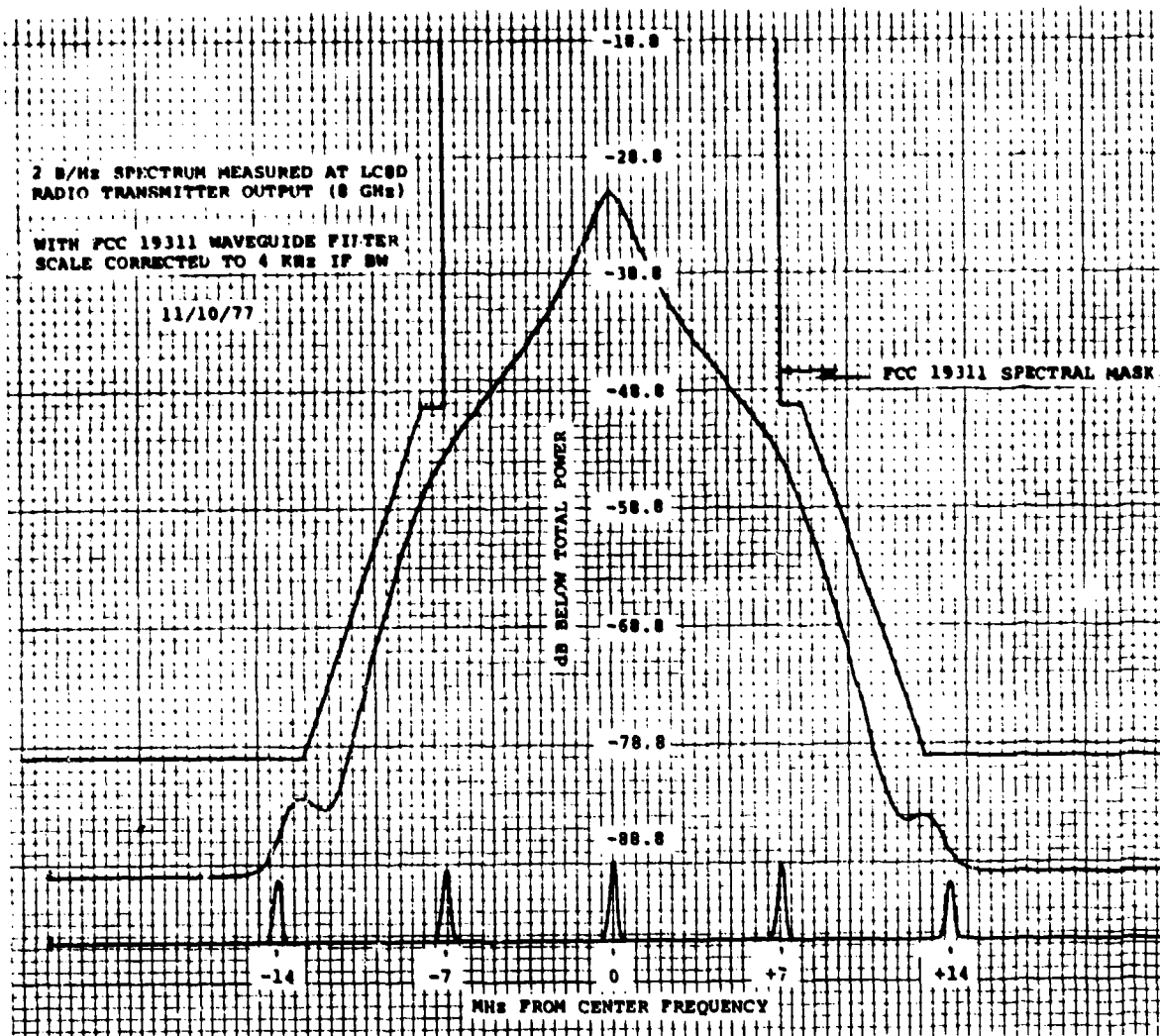

Figure 59. 2 B/Hz Spectrum Measured at LC8D Radio Transmitter Output (8 GHz) With FCC 19311 Waveguide Filter

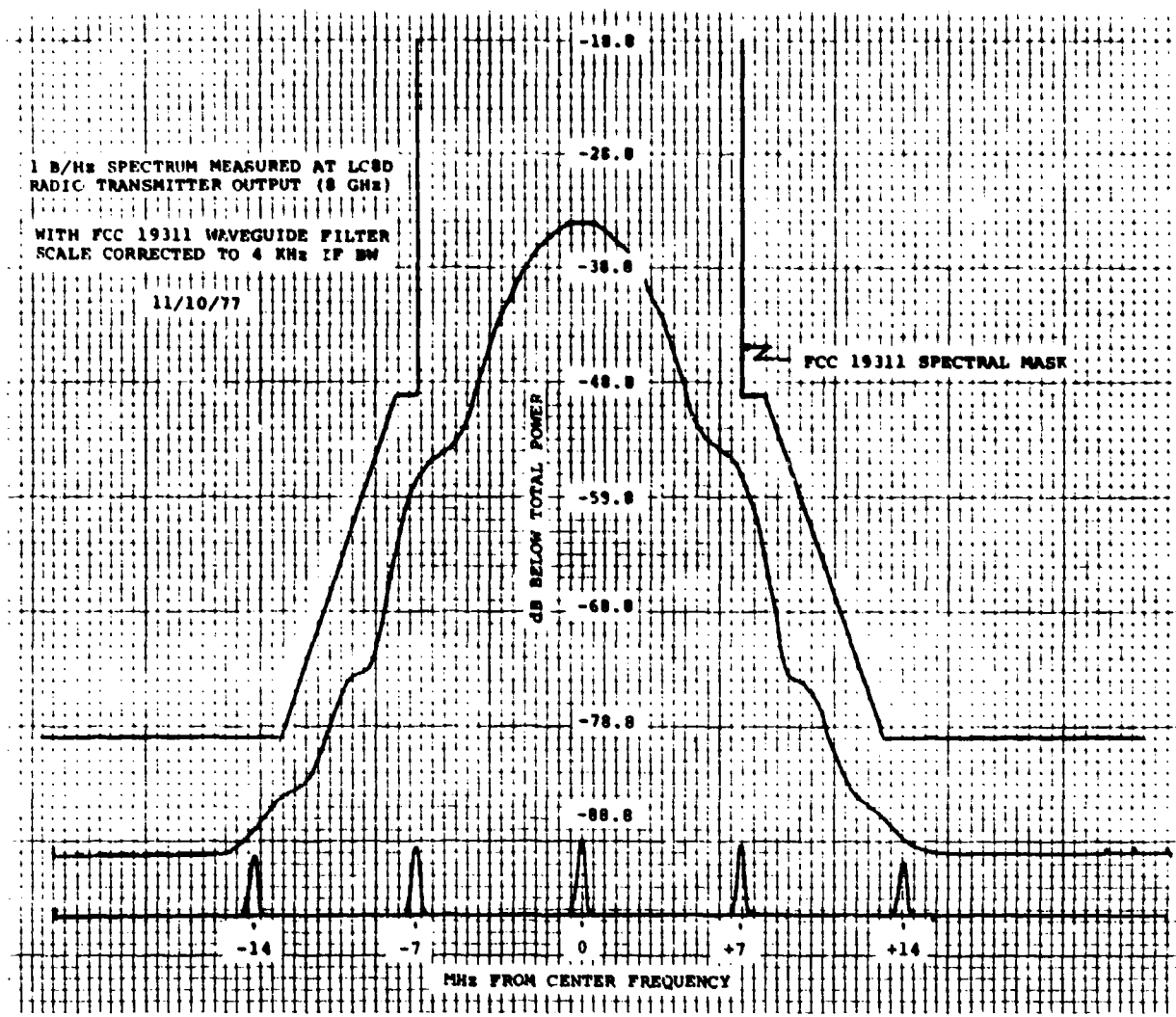

Figure 60. 1 B/Hz Spectrum Measured at LC8D Radio Transmitter Output (8 GHz) With FCC 19311 Waveguide Filter

It was noted that the measured peak of the spectra (at center frequency) is 3 to 4 dB lower than predicted by computer simulation. This was also observed on the photographs taken at Harris ESD. The discrepancy may perhaps be attributed to the operation of the spectrum analyzer which averages the log of the signal rather than averaging the signal before taking the log. However, even if the spectral plots are shifted upwards by 4 dB, they still fit within the FCC 19311 mask.

The spectra were also measured at the radio receiver IF output. Though the curves still fall below the FCC 19311 mask, the side lobes are somewhat stronger than those measured at 8 GHz. This is probably the result of limiting due to overload at the receiver downconverter. Tests were run with maximum signal level through the simulator. The spectral plots at the receiver IF are shown in Figures 61 and 62.

4.2.2 BER Versus E_b/N_0 Results

Bit error rate tests were run with the modem as received from shipment. No attempt was made to realign the modem to optimize its performance. The design objective was a BER of 5×10^{-9} or less at an E_b/N_0 of 22 dB over the LC8D radio in the 2 B/Hz mode. For the 1 B/Hz mode, the objective was 5×10^{-9} at an E_b/N_0 of 16 dB. These objectives were for operation without the randomizer which degrades performance by a factor close to three. The BER performance was measured in a variety of configurations, as described below. Unless otherwise noted, measurements were made with noise added at IF as with the in-plant tests at Harris ESD. This gave more repeatable results than the radio noise technique described in the Test Plan. Tests with radio noise were run, however, as a check on the validity of the IF noise measurement technique, and the results are included in this section.

4.2.2.1 2 B/Hz Test Results

Baseline performance data was obtained with a 70 MHz back-to-back test with additive Gaussian noise. The result is shown in Figure 63. The test was run with the randomizer operating. A BER of 5×10^{-9} was achieved at an E_b/N_0 of 21.1 dB. This represents a

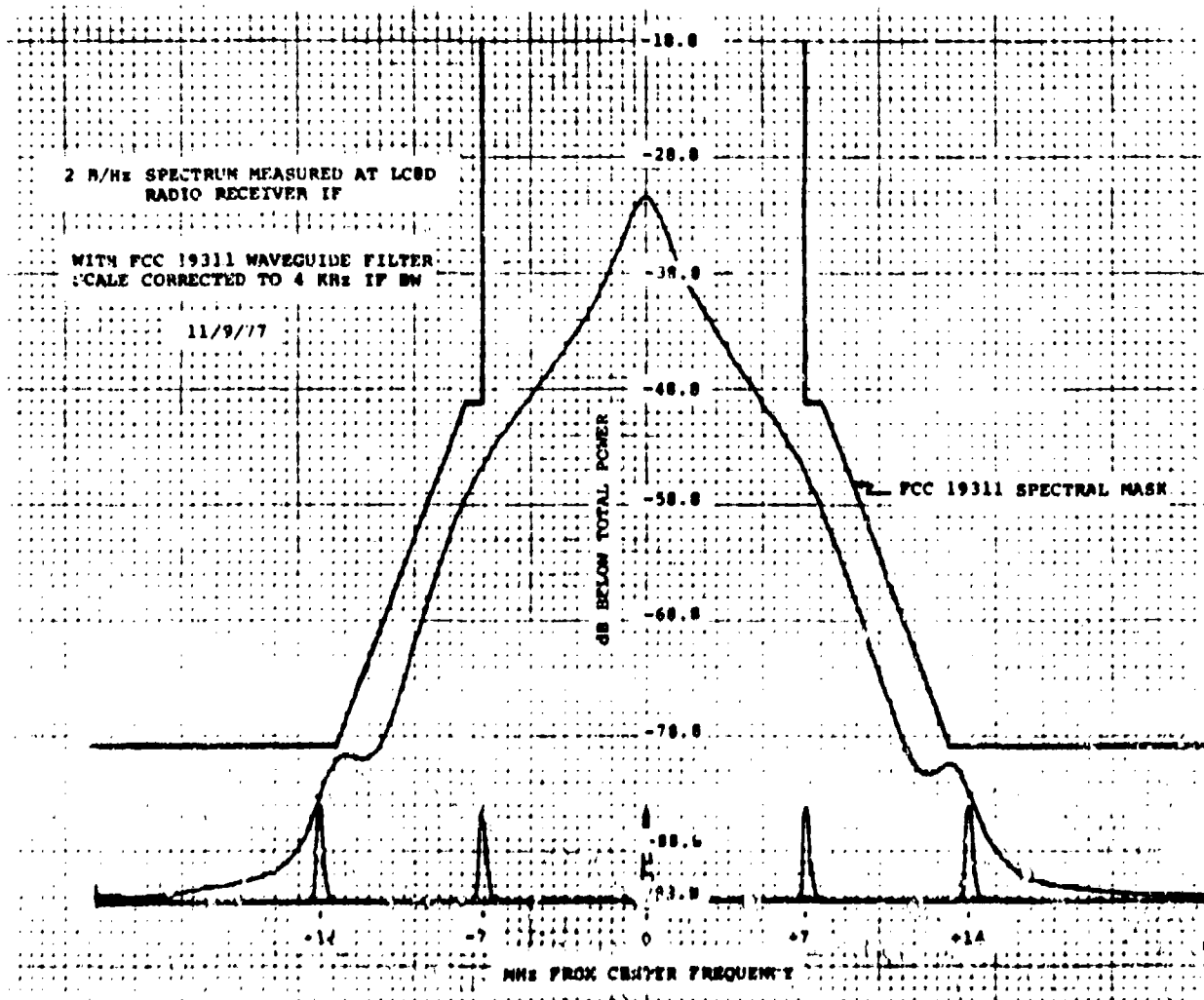

Figure 61. 2 B/Hz Spectrum Measured at LC8D Radio Receiver IF With FCC 19311 Filter

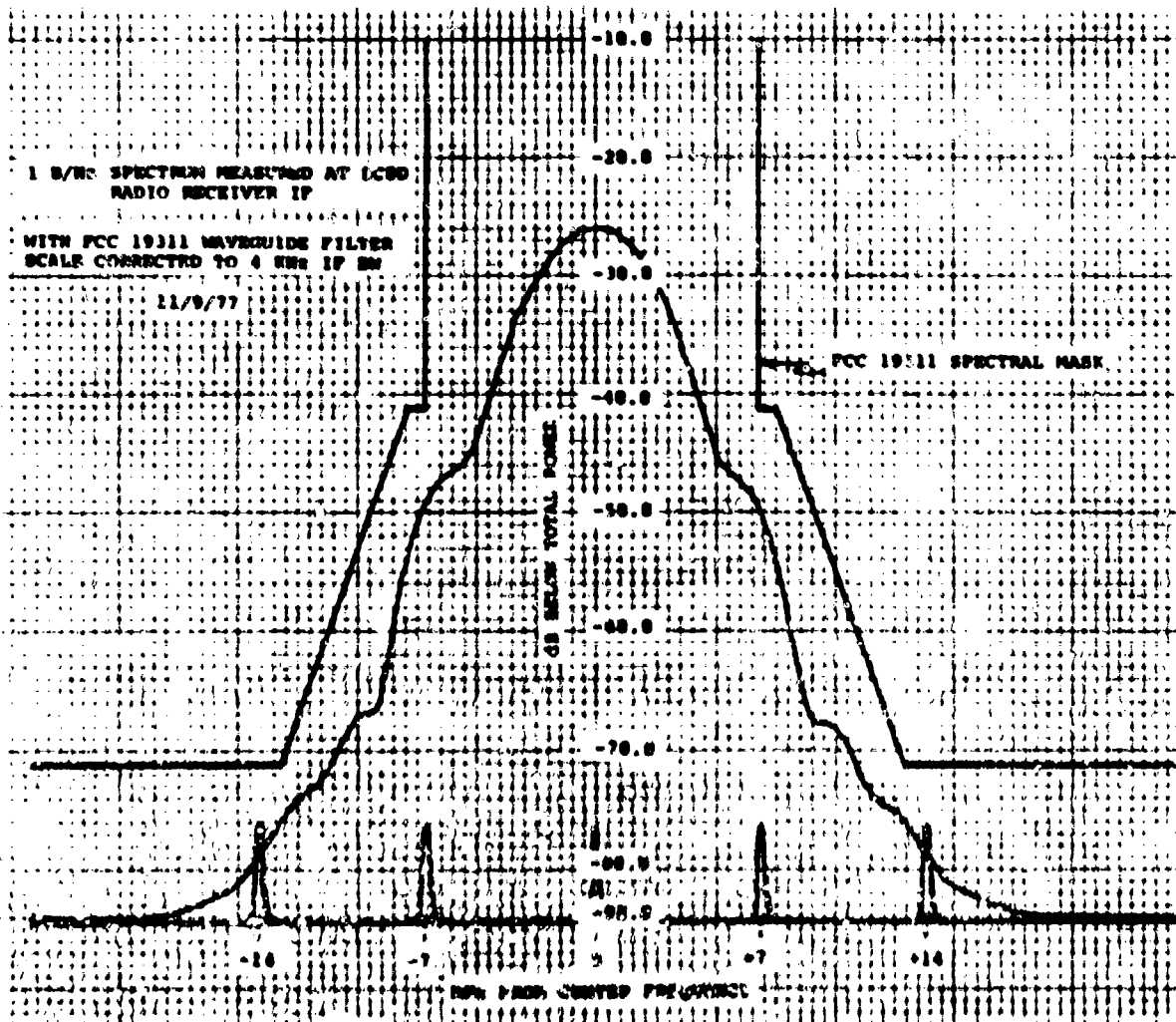

Figure 62. 1 B/Hz Spectrum Measured at LC80
Radio Receiver IF With FCC 19311 Filter

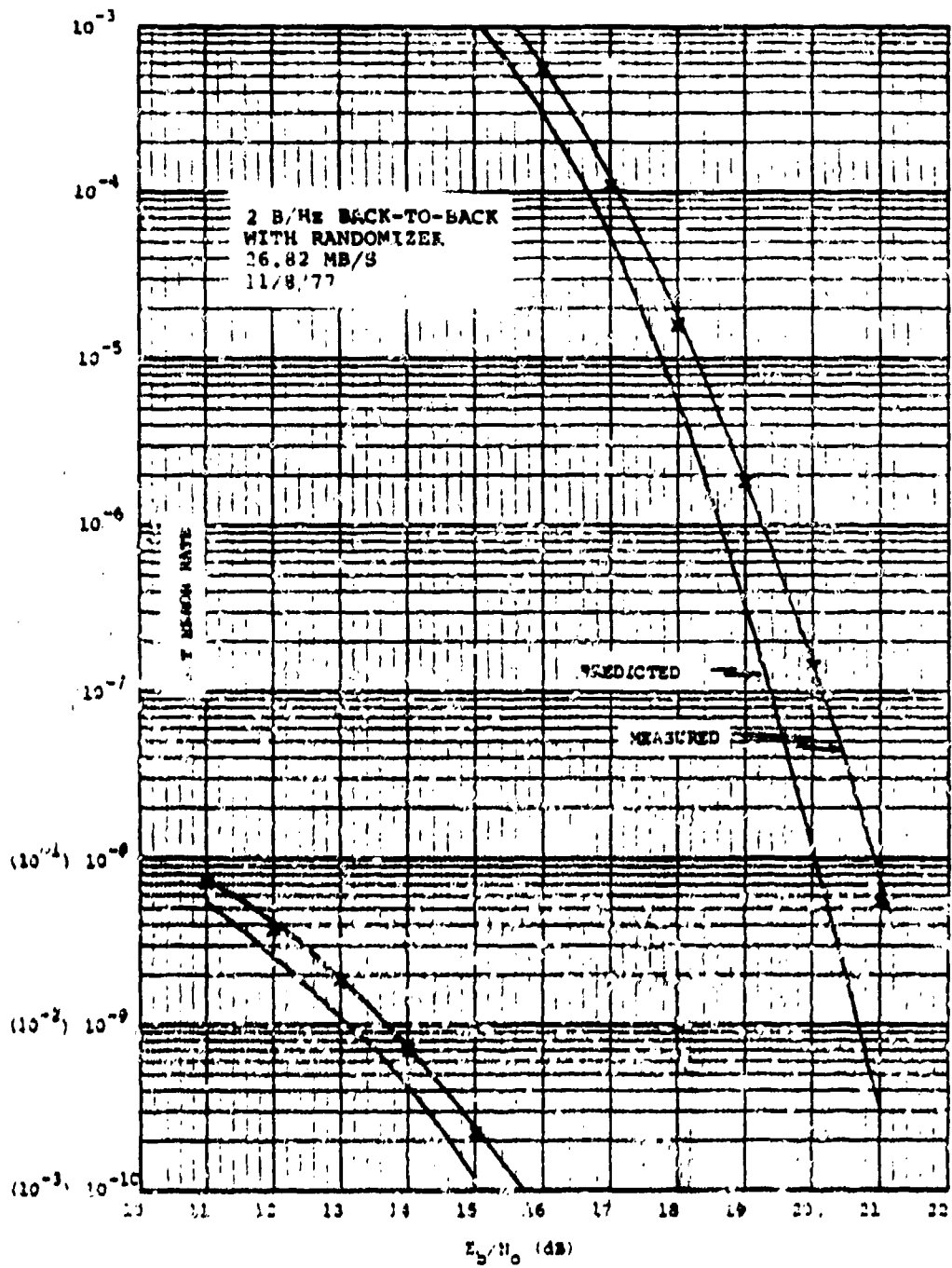

Figure 63. BER-2 B/Hz, Back-to-Back, With Randomizer

degradation of approximately 0.2 dB from that measured during the in-plant tests at Harris ESD. This is close to measurement accuracy and represents excellent stability through shipping.

The second test at RADC was operation through the LC8D radio and simulator without the FCC 19311 waveguide filter. The simulator connected the radio back-to-back. Thermal noise was added to the radio IF output for E_b/N_0 calibration. The simulator was set for minimum signal attenuation and the modem randomizer was utilized. An external data source and error detector were used for convenience in measurement. A BER of 5×10^{-9} was measured at an E_b/N_0 of 21.5 dB. The complete curve is shown in Figure 64.

The above test was then repeated with the FCC 19311 waveguide filter installed in the LC8D radio transmitter. The resulting curve is shown in Figure 65. A BER of 5×10^{-9} occurred at an E_b/N_0 of 23.2 dB. The randomizer was then bypassed so that the results could be compared more easily with those obtained at Harris ESD with the up/downconverter. This curve is shown in Figure 66. A BER of 5×10^{-9} was measured at an E_b/N_0 of 23.2 dB as before. The factor of three improvement did not materialize due to error in measurement repeatability. This is within 0.3 dB of that obtained at Harris ESD with the up/downconverter (Figure 48).

Figure 67 shows the BER performance with randomizer through the radio with FCC 19311 filter and AGC amplifier. Comparison with Figure 65 reveals that the IF AGC amplifier in the LC8D degrades performance by approximately 0.6 dB in the vicinity of a 10^{-8} BER. The AGC amplifier was found to introduce additional group delay distortion that is a function of amplifier gain (and, hence, receive level). Distortion peaks at maximum received level (minimum gain). A plot of performance with the AGC amplifier but without randomizer is shown in Figure 68. A BER of 5×10^{-9} was achieved at an E_b/N_0 of 23.4 dB without group delay compensation. This is 1.4 dB from the design objective.

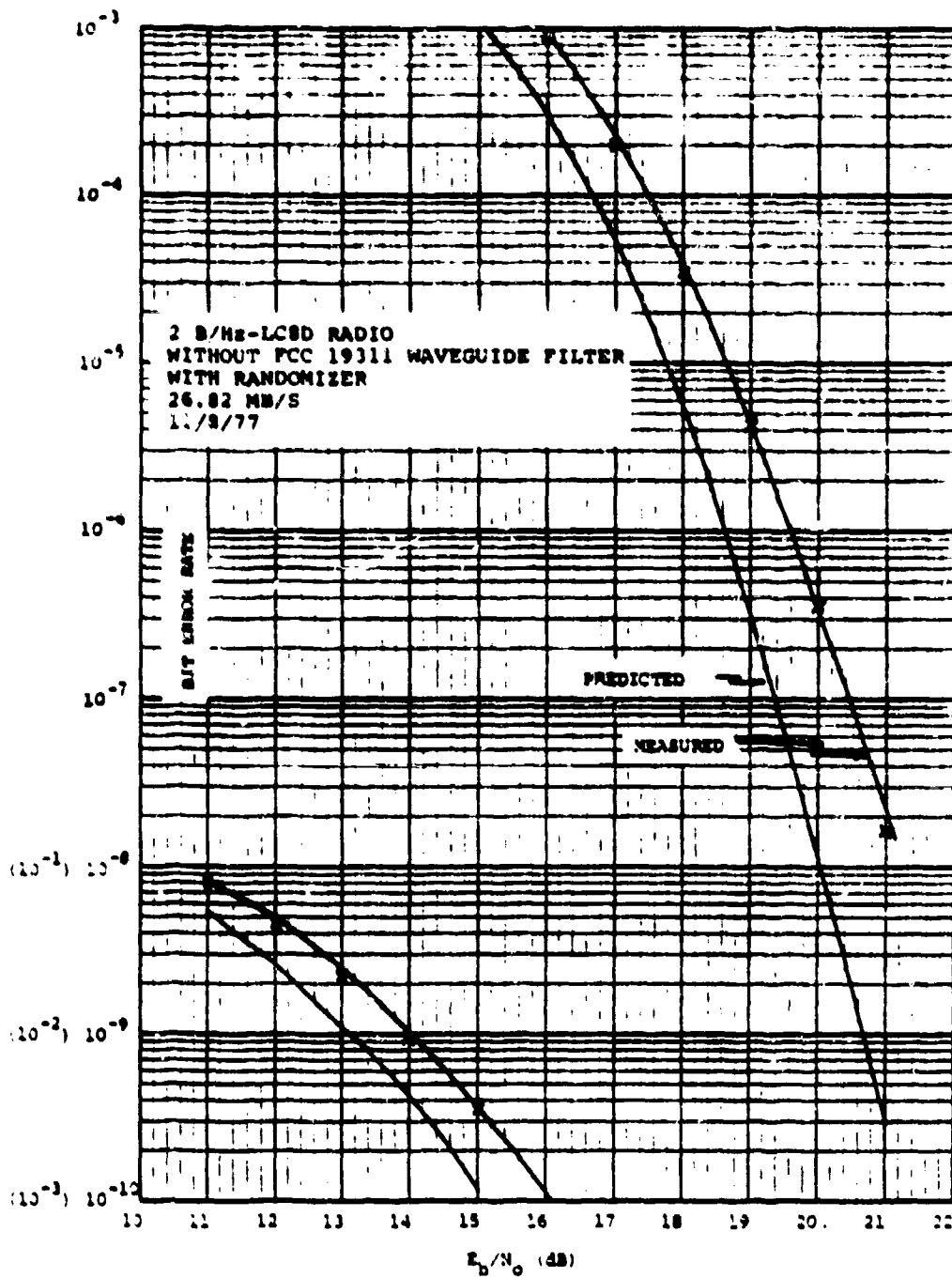

Figure 64. BER-2 B/Hz, LCSD Radio, Without FCC 19311 Waveguide Filter, With Randomizer

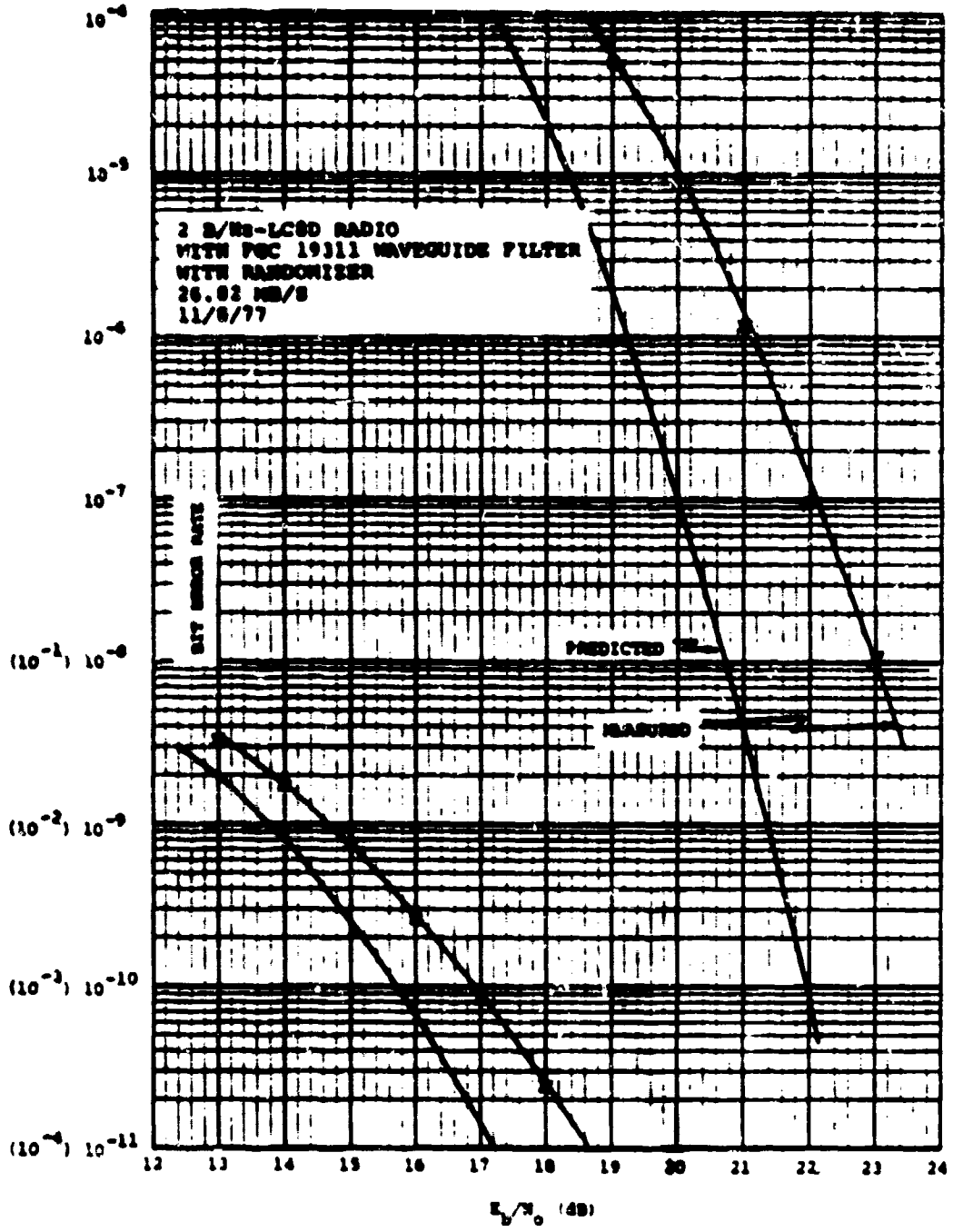

Figure 65. BER-2 B/Hz, LCSD Radio, With FCC 19311 Waveguide Filter and Randomizer

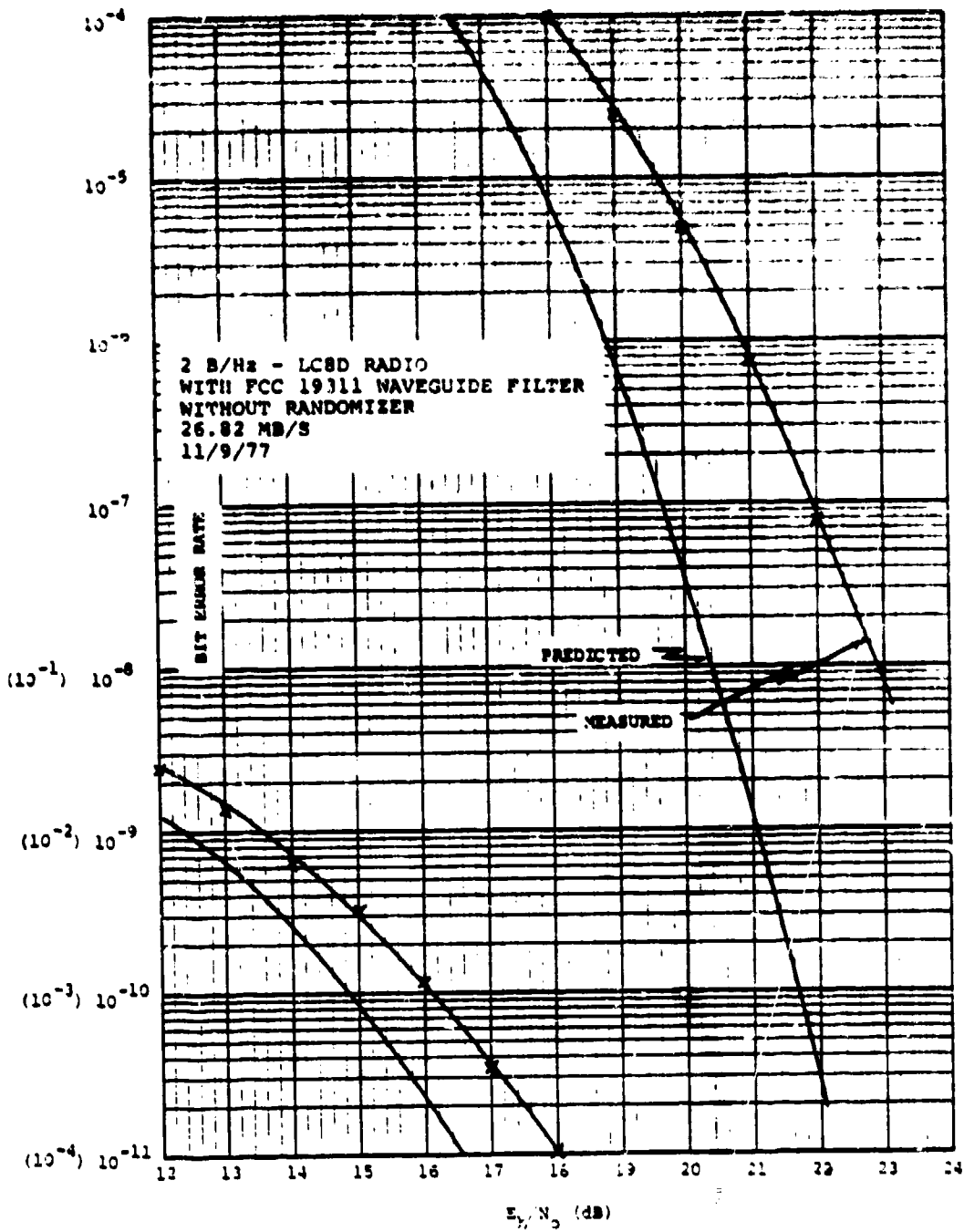

Figure 66. BER-2 B/Hz, LC8D Radio, With FCC 19311 Waveguide Filter, Without Randomizer

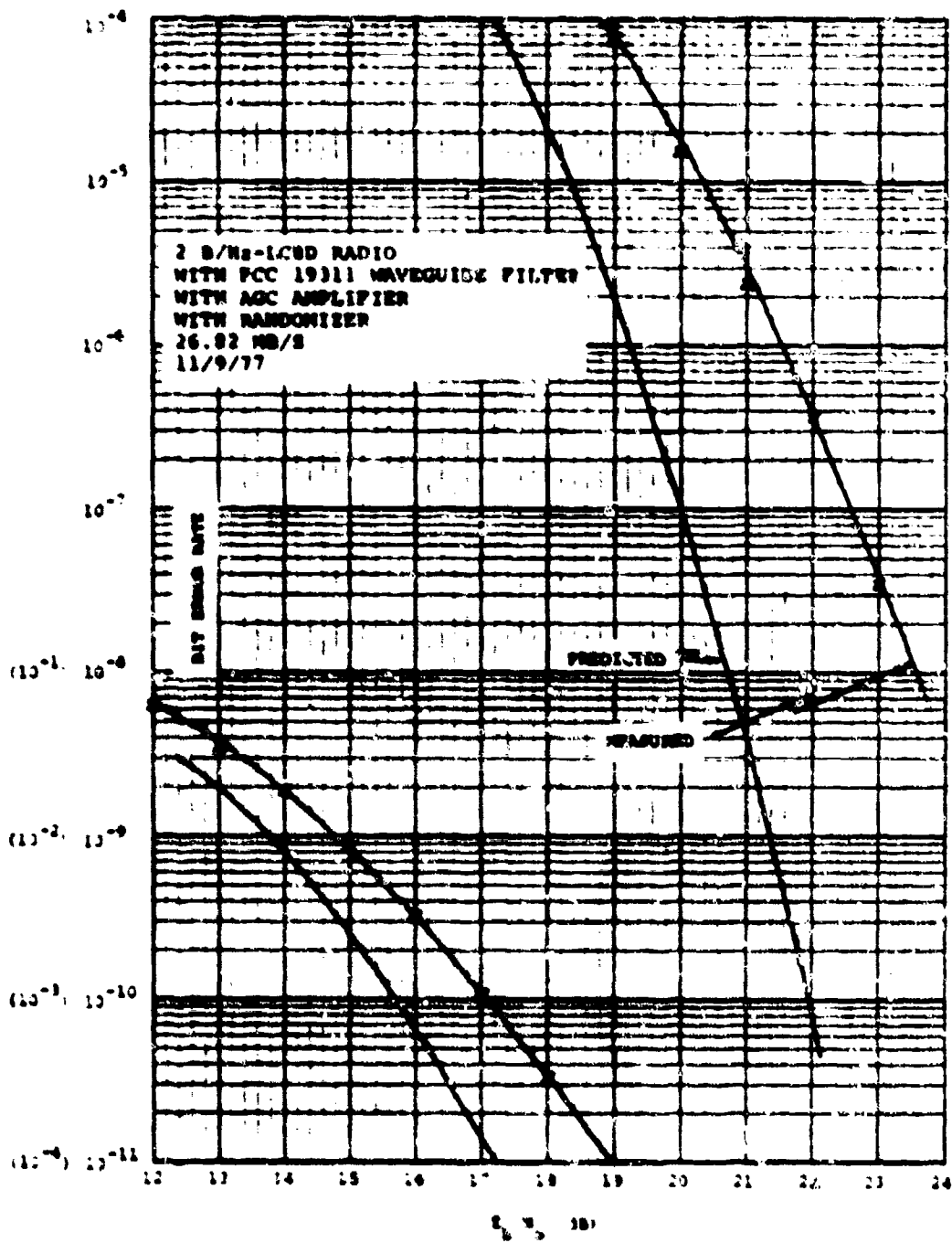

Figure 67. BER-2 B/Hz, LCSD Radio, With FCC 19311 Waveguide Filter, AGC Amplifier and Randomizer

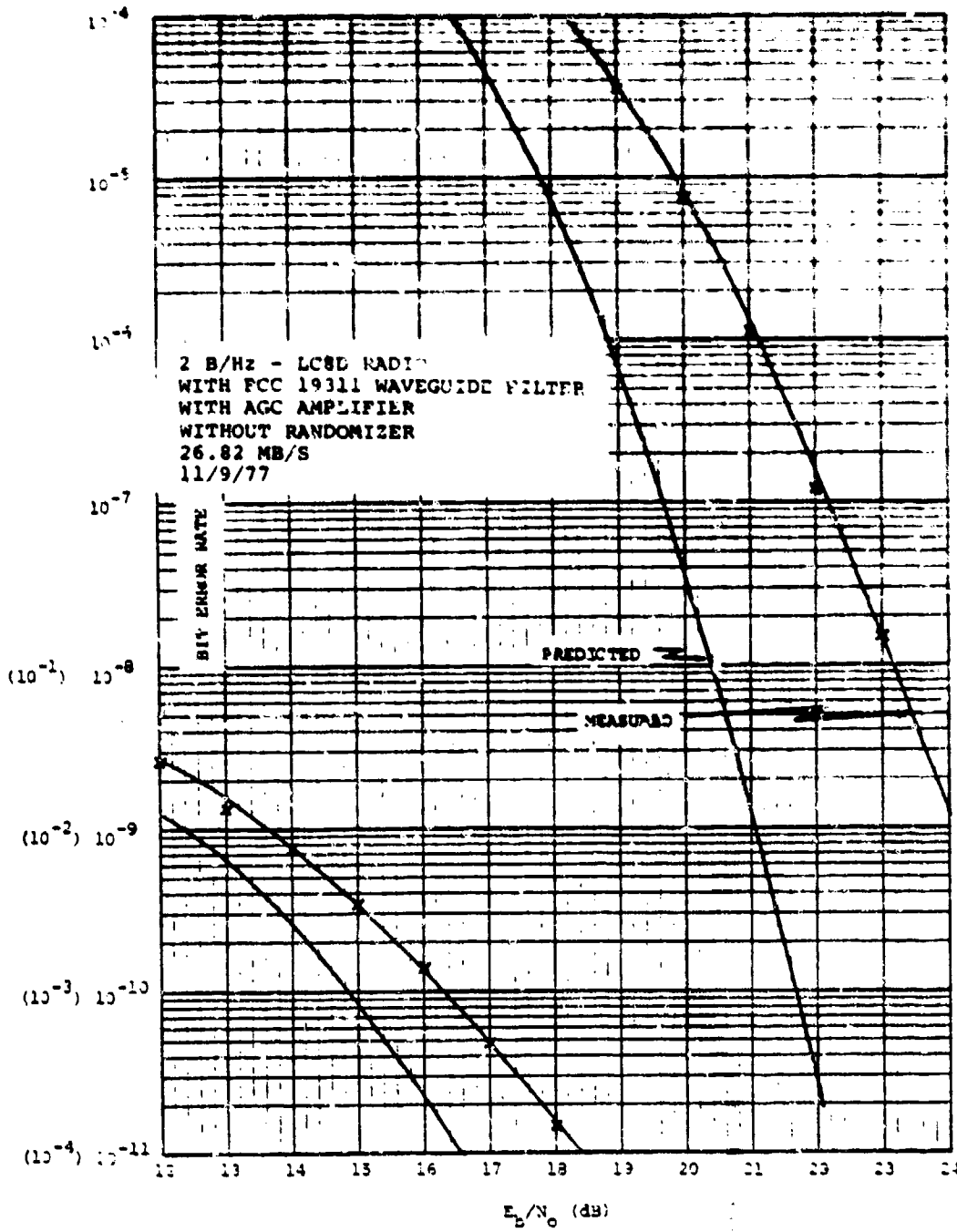

Figure 68. BER-2 B/Hz, LC8D Radia, With FCC 19311 Waveguide Filter and AGC Amplifier, Without Randomizer

An attempt was made to equalize the LC80 radio at IF with the FCC 19311 waveguide filter and AGC amplifier installed. A plot of amplitude response and group delay before equalization is shown in Figure 69. A single section of group delay equalization ($4/25 \text{ ns/MHz}^2$ parabolic) provided considerable improvement as can be seen in Figure 70. BER performance with this equalization is shown in Figure 71. A BER of 5×10^{-9} was measured at an E_b/N_0 of 22.6 dB. This is only 0.6 dB from the design goal and represents an improvement of 1.0 dB over the unequalized radio (Figure 67). Note that the data in Figure 71 was obtained with randomizer. The design objective with randomizer becomes 1.5×10^{-8} BER at an E_b/N_0 of 22 dB. This bit error rate was achieved at an E_b/N_0 of 22.2 dB. Thus, performance with the equalized radio is essentially within 0.2 dB of the design objective.

Further attempts to improve the equalization did not improve BER performance significantly. Optimum group delay and amplitude response were achieved with the following equalization sections:

- (1) $4/25 \text{ ns/(MHz)}^2$ parabolic group delay
- (2) $-8/10 \text{ ns/MHz}$ linear group delay
- (3) $+0.2 \text{ dB/MHz}$ amplitude
- (4) $+0.1 \text{ dB/MHz}$ amplitude

As a check on the test set which added Gaussian noise at IF, two curves were run using the noise coming from the radio itself and attenuating the received power level in the simulator to adjust E_b/N_0 . Calibration was achieved by measuring radio noise alone and then increasing signal power until that level increased by 3 dB, thus setting the 0 dB S/N point. Corrections were then made to determine E_b/N_0 based on the noise filter bandwidth. Calibration by this method was found to be less repeatable than with the IF test set and was probably accurate only to within $\pm 0.5 \text{ dB}$. Figure 72 shows results with radio noise and unequalized radio. Figure 73 shows results with radio noise on the equalized radio. Both curves show a BER of 5×10^{-9} at an E_b/N_0 near 22.4 dB. No gain is shown using equalization but this is a result of calibration error

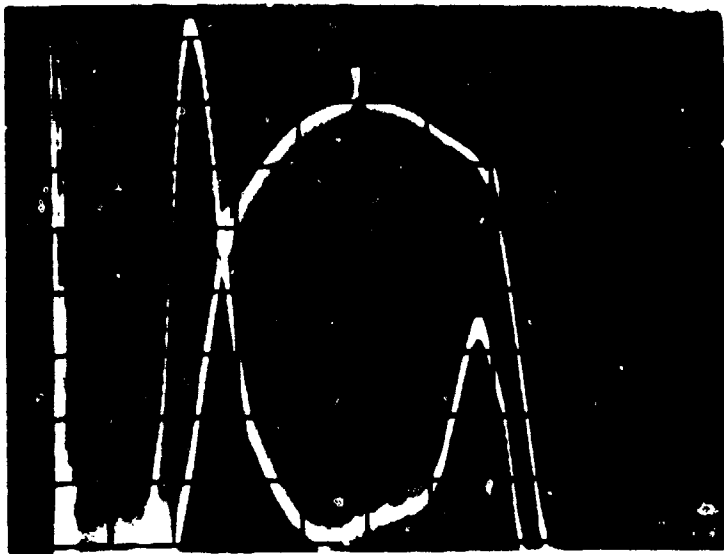

UPPER TRACE- AMPLITUDE
RESPONSE, 2 dB/DIV,
MARKERS AT ±7 MHz

LOWER TRACE- GROUP DELAY,
5 ns/DIV

11/9/77

Figure 69. Amplitude Response and Group Delay of LC8D With
FCC 19311 Filter, Without Equalization

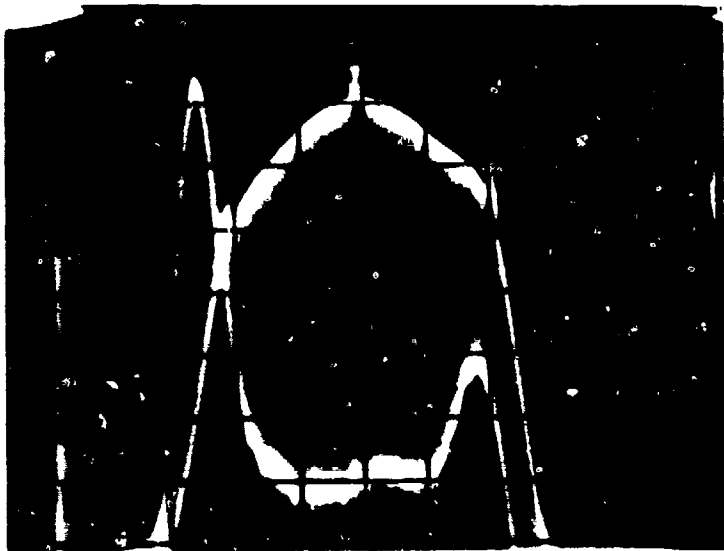

LC8D WITH FCC 19311₂ FILTER
WITH $4/25$ ns/MHz²
PARABOLIC EQUALIZATION

UPPER TRACE- AMPLITUDE
RESPONSE, 2 dB/DIV
MARKERS AT ±7 MHz

LOWER TRACE- GROUP DELAY,
5 ns/DIV

11/9/77

Figure 70. Amplitude Response and Group Delay of LC8D With FCC 19311
Filter, with $4/25$ ns/MHz² Parabolic Group Delay Equalization

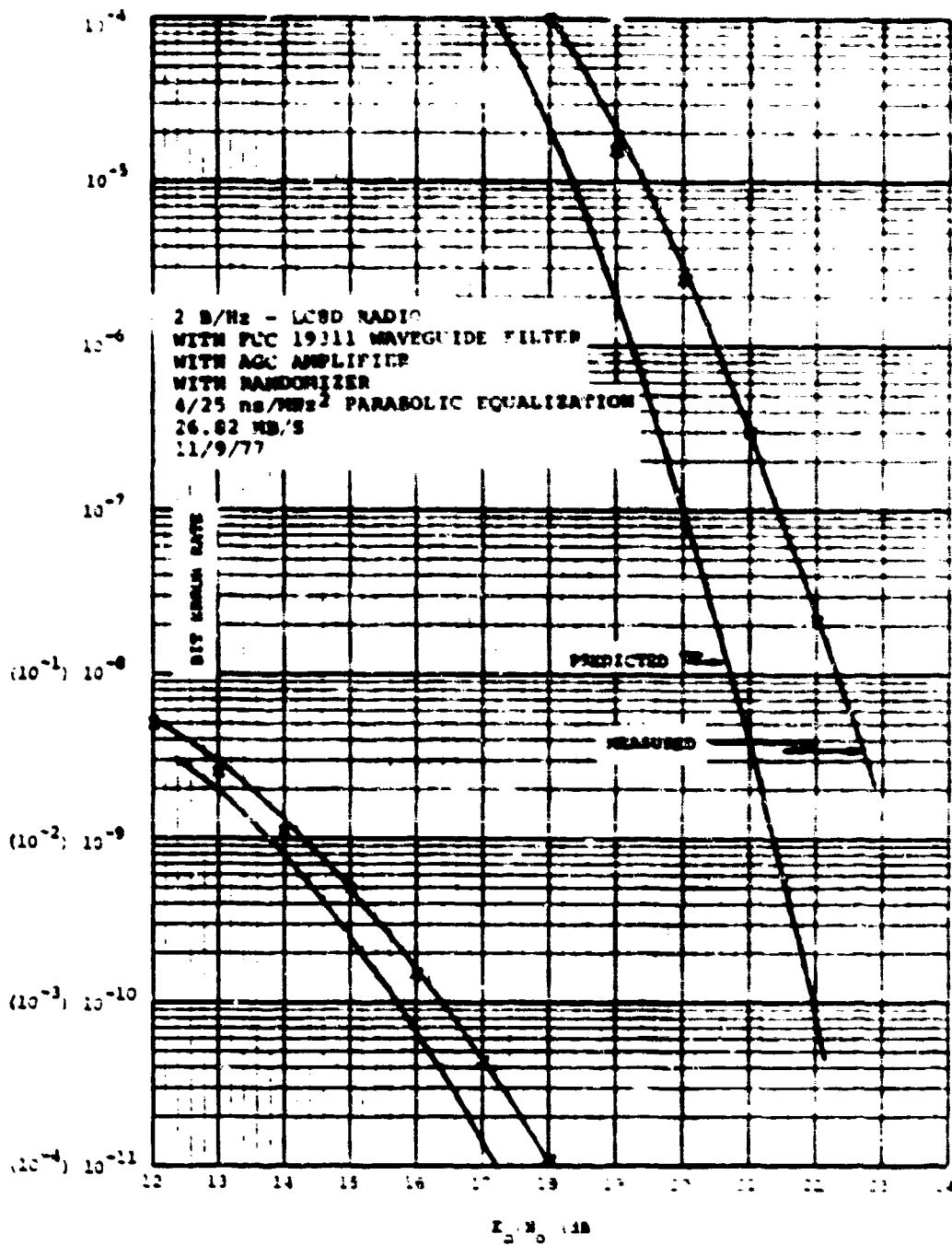

Figure 71. BER-2 B/Hz, LCSD Radio, With FCC 19311 Waveguide Filter, AGC Amplifier, Randomizer, and 4/25 ns/MHz² Parabolic Equalization

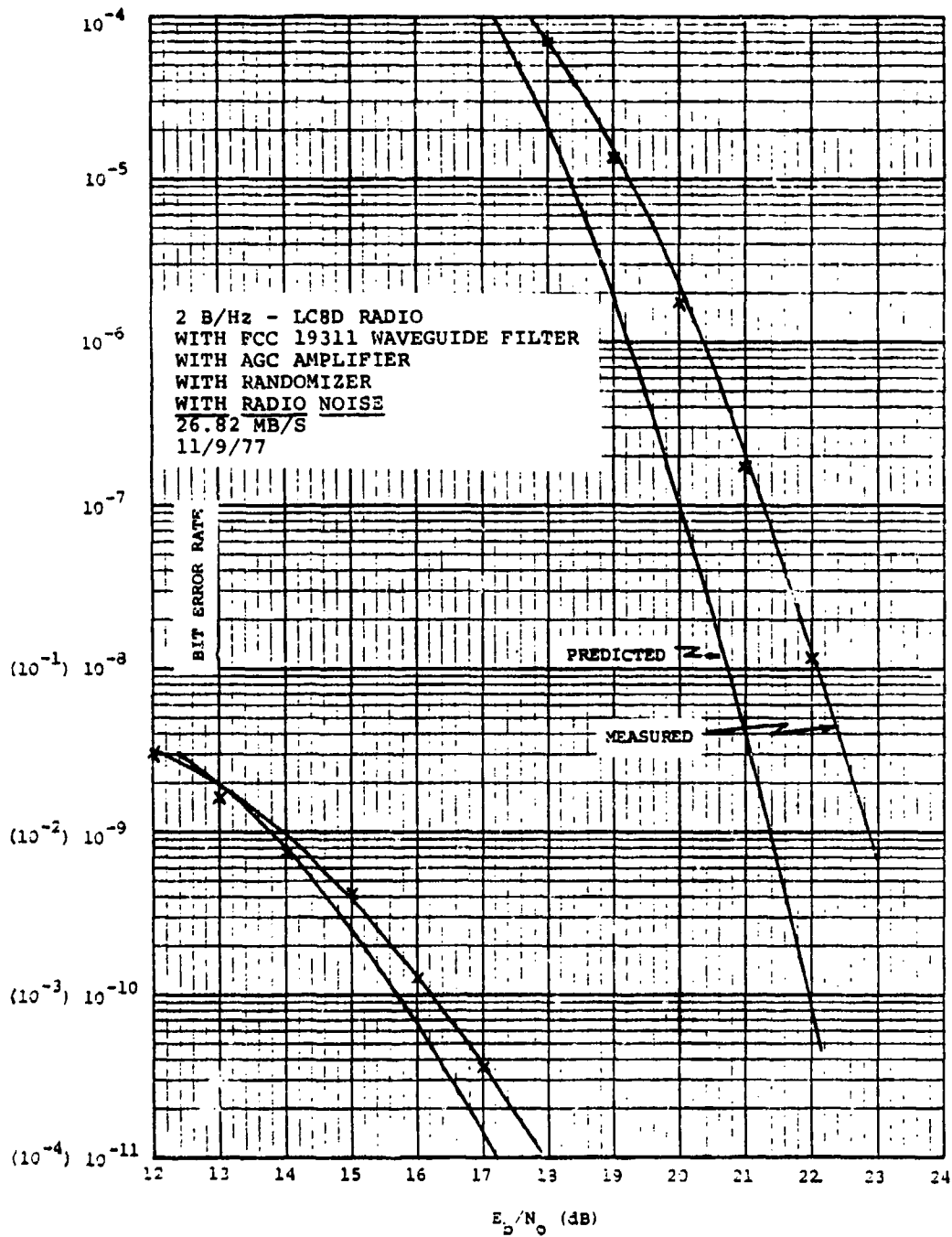

Figure 72. BER-2 B/Hz, LC8D Radio, With FCC 19311 Waveguide Filter, AGC Amplifier, Randomizer, and Radio Noise

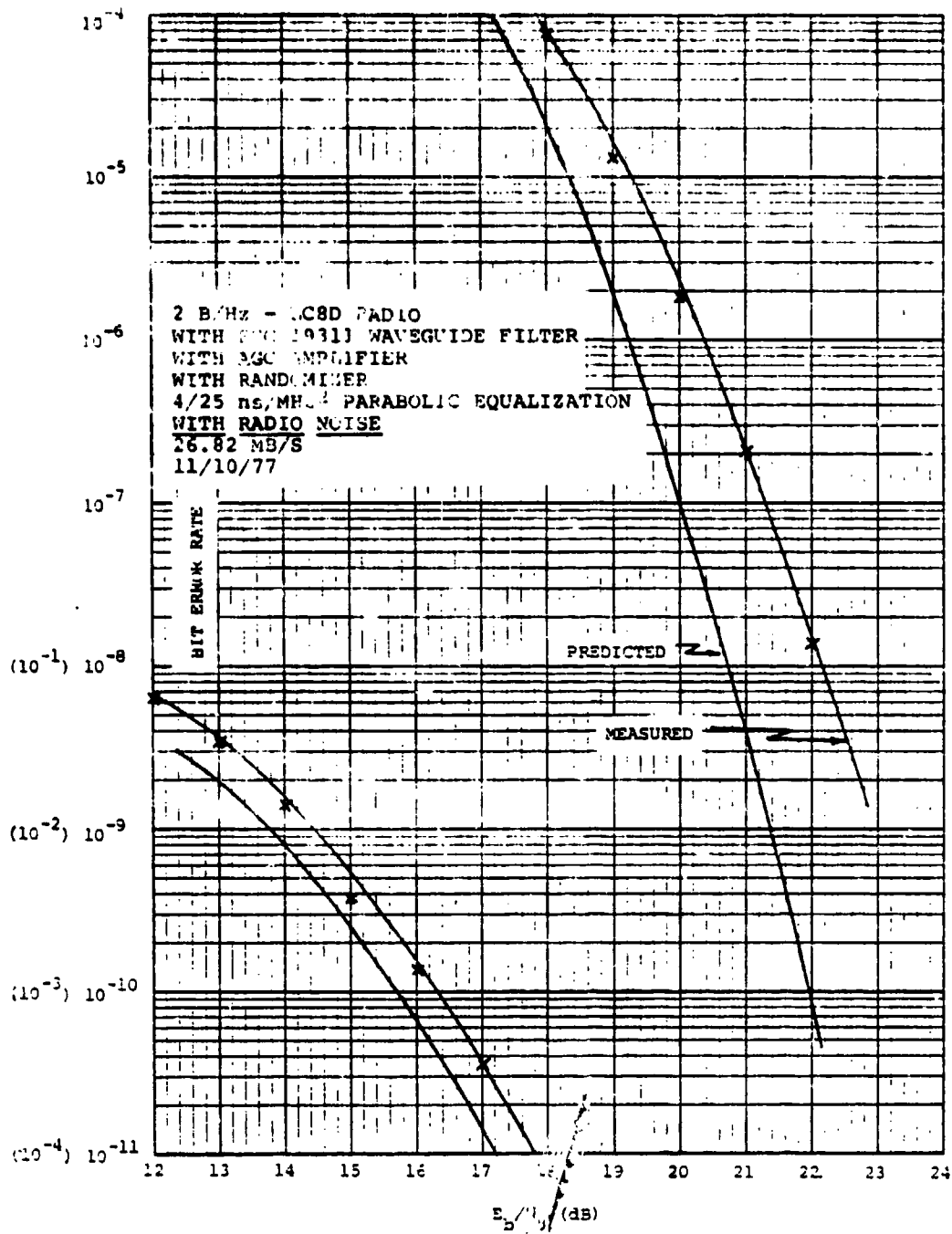

Figure 73. BE⁻² B/Hz, LC8D Radio, With FCC 19311 Waveguide Filter, AGC Amplifier Randomizer, 4/25 ns/MHz² Parabolic Equalization, and Radio Noise

using this technique. However, results do compare within measurement accuracy to those obtained with IF noise, demonstrating the validity of the measurement technique.

4.2.2.2 1 B/Hz Results

The 1 B/Hz back-to-back performance as measured with additive IF noise is depicted in Figure 74. A 5×10^{-9} BER was measured with randomizer at an E_b/N_0 of 15.9 dB. Through the radio without FCC 19311 filtering, this BER occurred at an E_b/N_0 of 16 dB as seen in Figure 75. The addition of the FCC 19311 waveguide filter degraded performance by approximately 0.4 dB as shown in Figure 76. The curve measured through the radio and filter but without randomizer is shown in Figure 77. A BER of 5×10^{-9} was achieved at an E_b/N_0 of 15.9 dB. This is slightly better than the design objective.

The addition of the 70 MHz IF AGC amplifier in the Philco Ford LC8D had little effect on performance. The shift in the curves could be attributed to variations in measurement. Figure 78 shows the measured data with randomizer and Figure 79 without. Performance with randomizer actually measures slightly better (approximately 0.1 dB) with AGC than without. The data for the two cases were taken on different days, however, and this can easily account for the apparent discrepancy. Performance without the randomizer measures approximately 0.25 dB worse with AGC than without (Figures 79 and 77 respectively). As these two sets of data were taken the same day, they are probably indicative of the actual degradation caused by the AGC. Without randomizer but with 19311 filtering and AGC, a BER of 5×10^{-9} was measured at an E_b/N_0 of 16.2 dB.

The $4/25 \text{ ns/MHz}^2$ parabolic group delay equalization that gained approximately 1.0 dB in 2 B/Hz BER performance had little effect on 1 B/Hz BER performance. A plot of data taken through the equalized radio with AGC and randomizer is shown in Figure 80. A BER of 5×10^{-9} occurred at an E_b/N_0 of 16.3 dB. If one assumes a degradation of a factor of three for the randomizer, the design objective becomes 1.5×10^{-8} at 16 dB. Figure 80 shows that this is narrowly met.

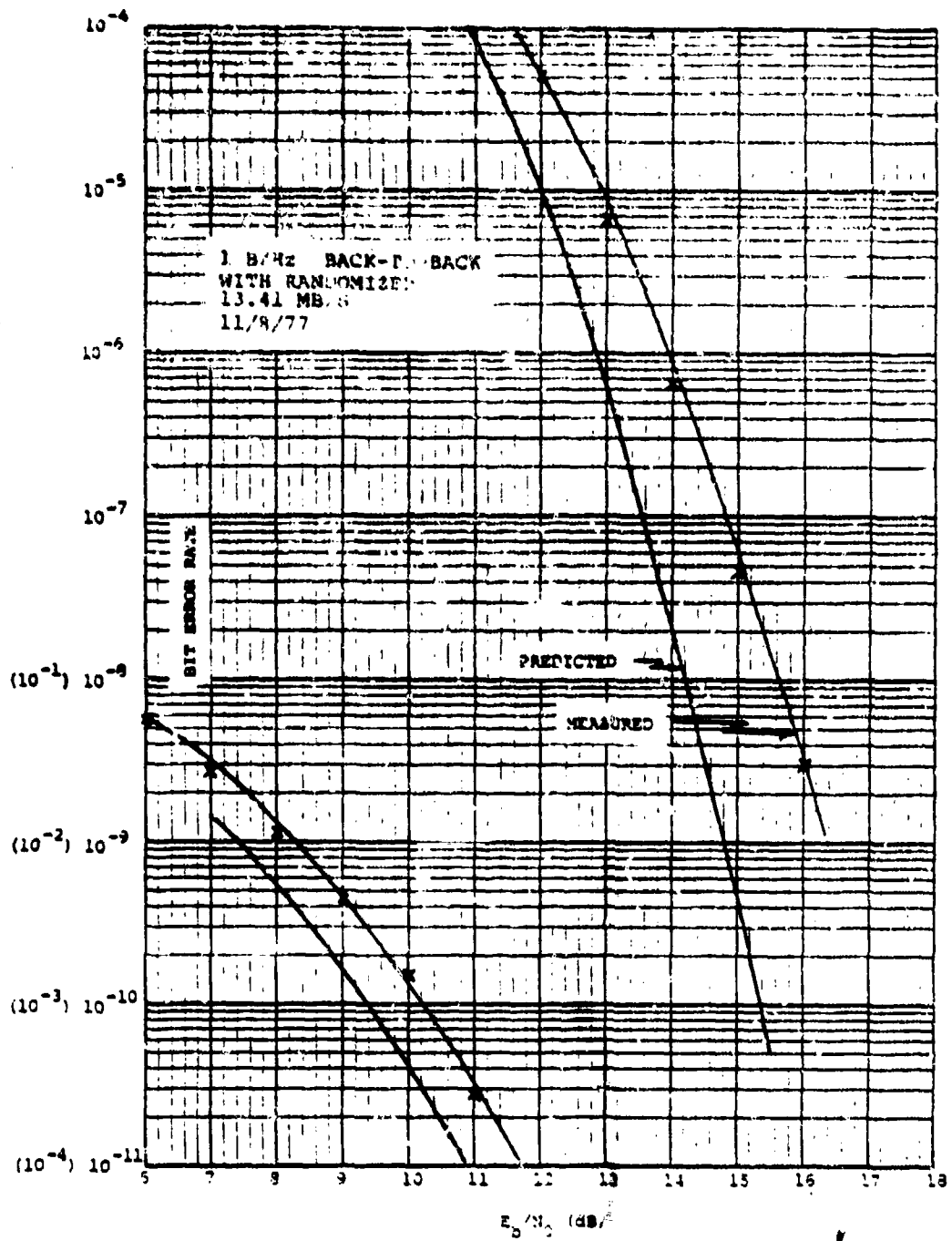

Figure 74. BER-1 B/Hz, Back-to-Back, With Randomizer

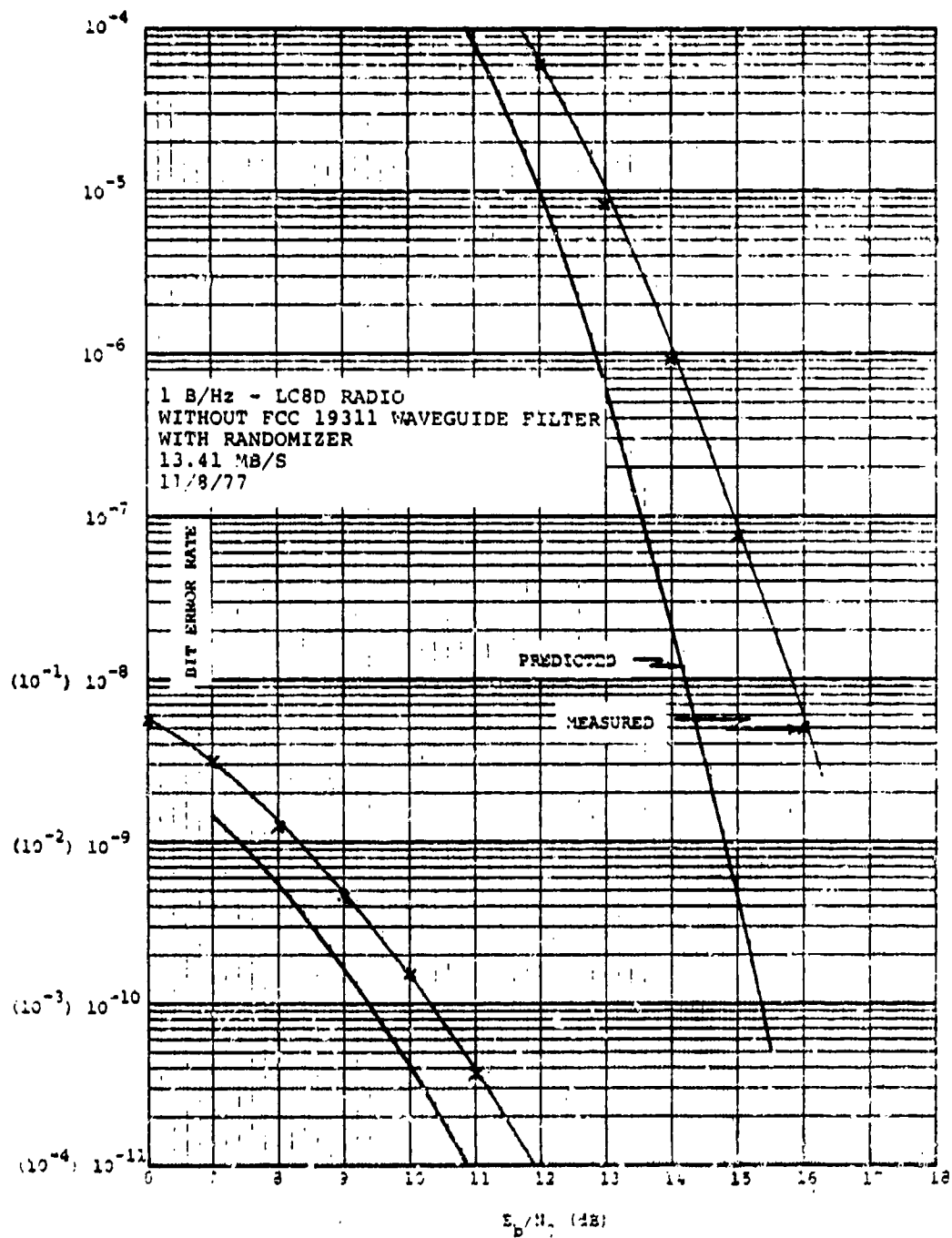

Figure 75. BER-1 B/Hz, LCSD Radio, Without FCC 19311 Waveguide Filter, With Randomizer

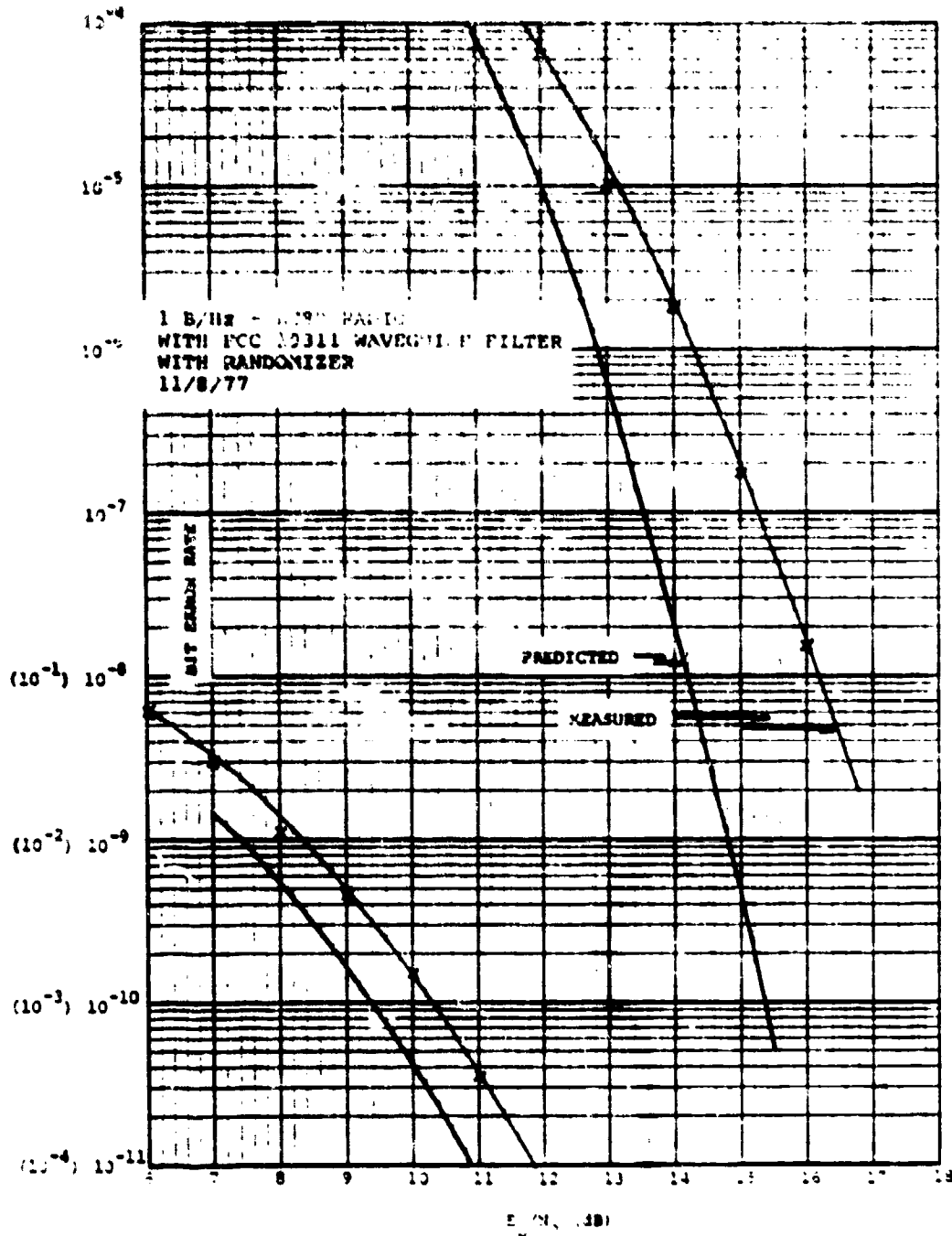

Figure 76. BER-1 B/H.; LC8D Radio, With FCC 19311 Waveguide Filter and Randomizer

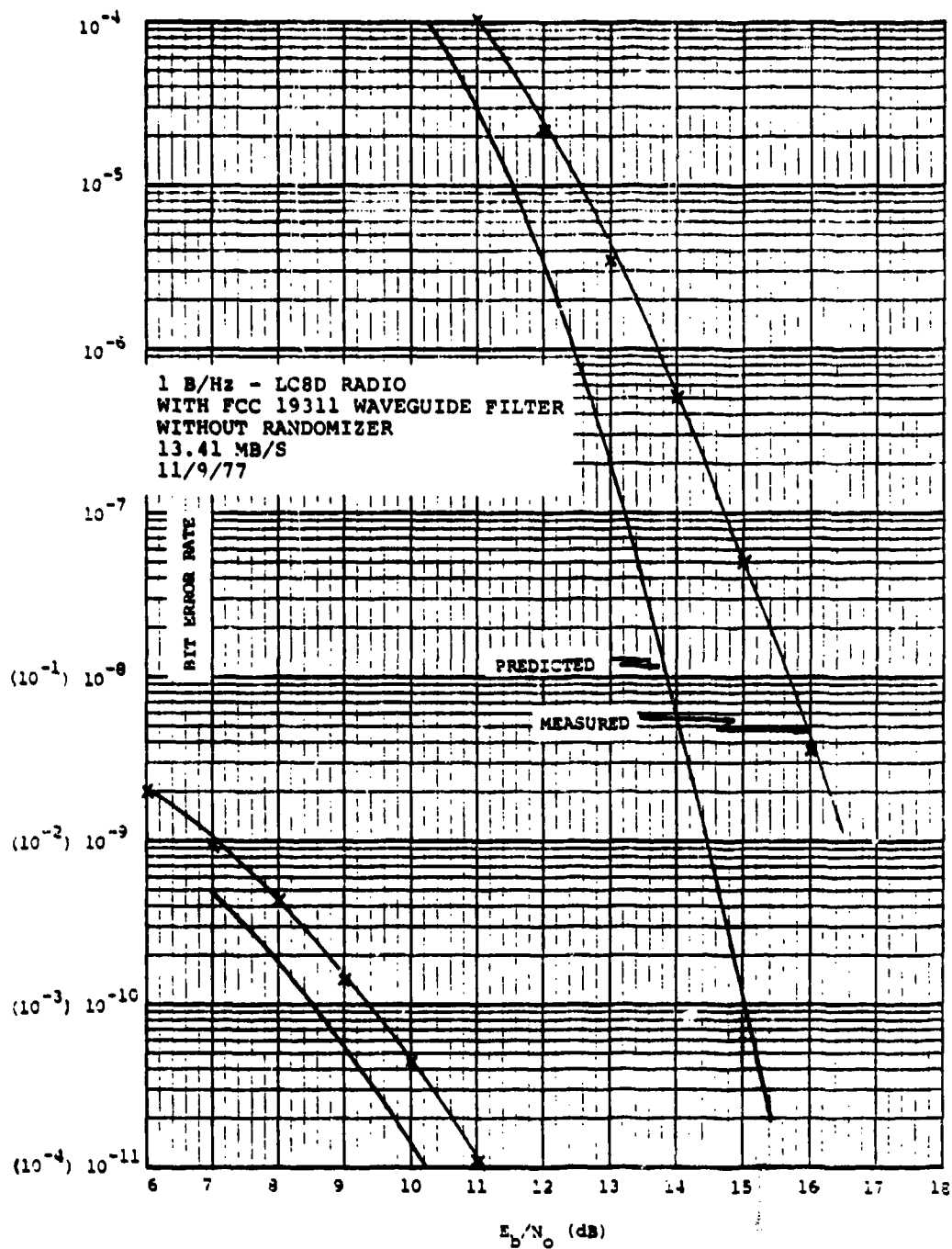

Figure 77. BER-1 B/Hz, LC8D Radio, With FCC 19311 Waveguide Filter, Without Randomizer

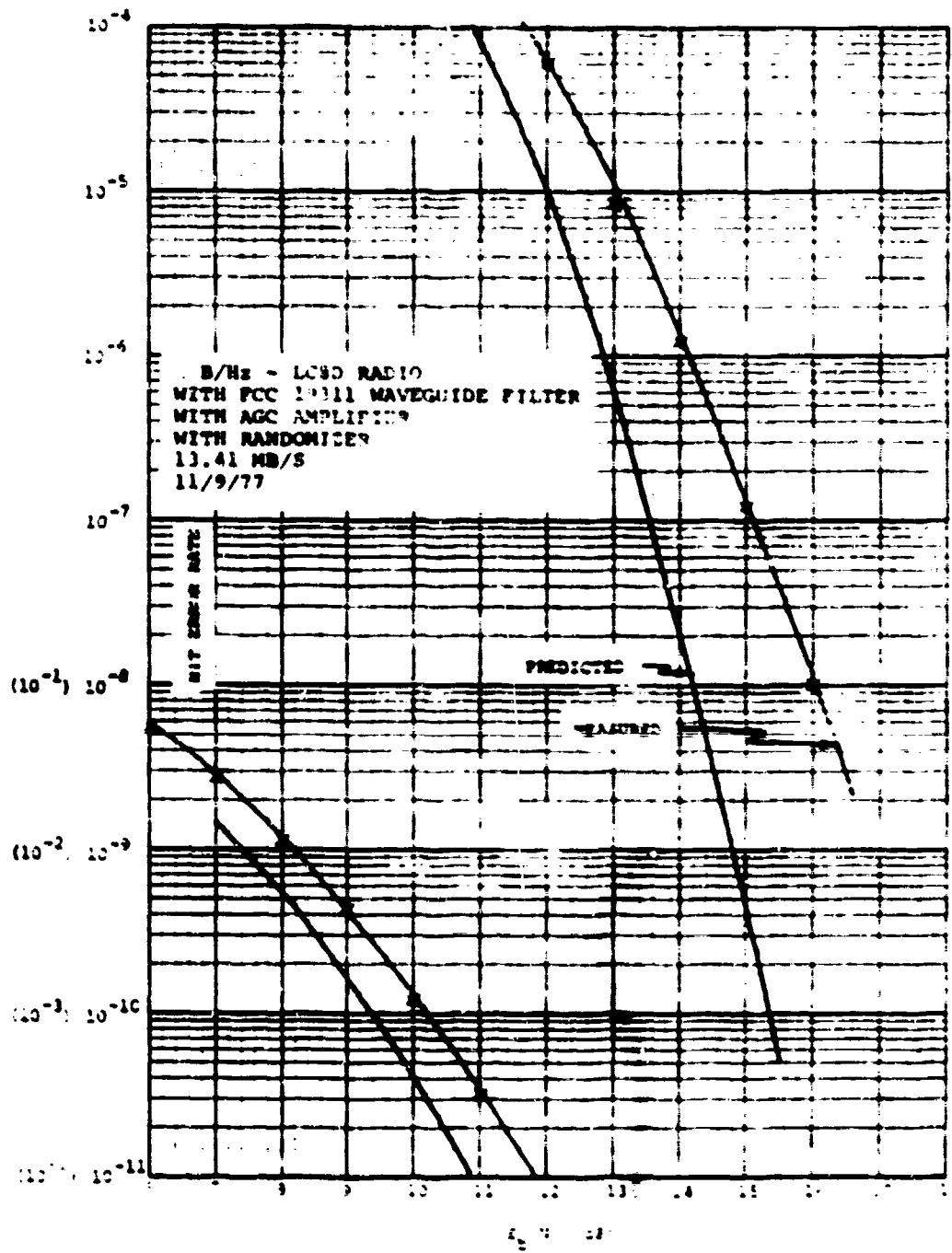

Figure 78. BER-1 B/Hz, LC8D Radio, With FCC 1911 Waveguide Filter, AGC Amplifier, and Randomizer

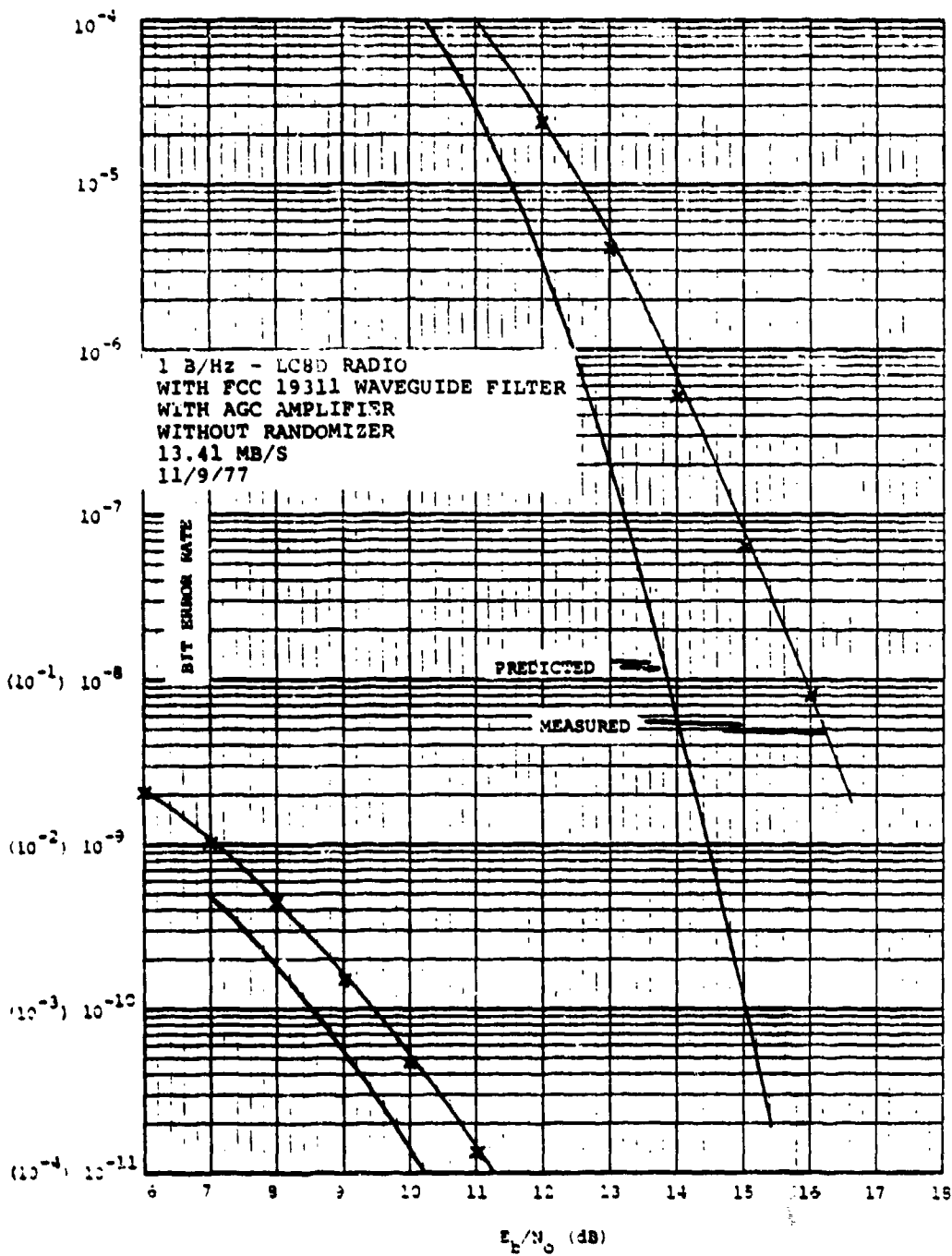

Figure 79. BER-1 B/Hz, LC8D Radio, With FCC 19311 Waveguide Filter, and AGC Amplifier, Without Randomizer

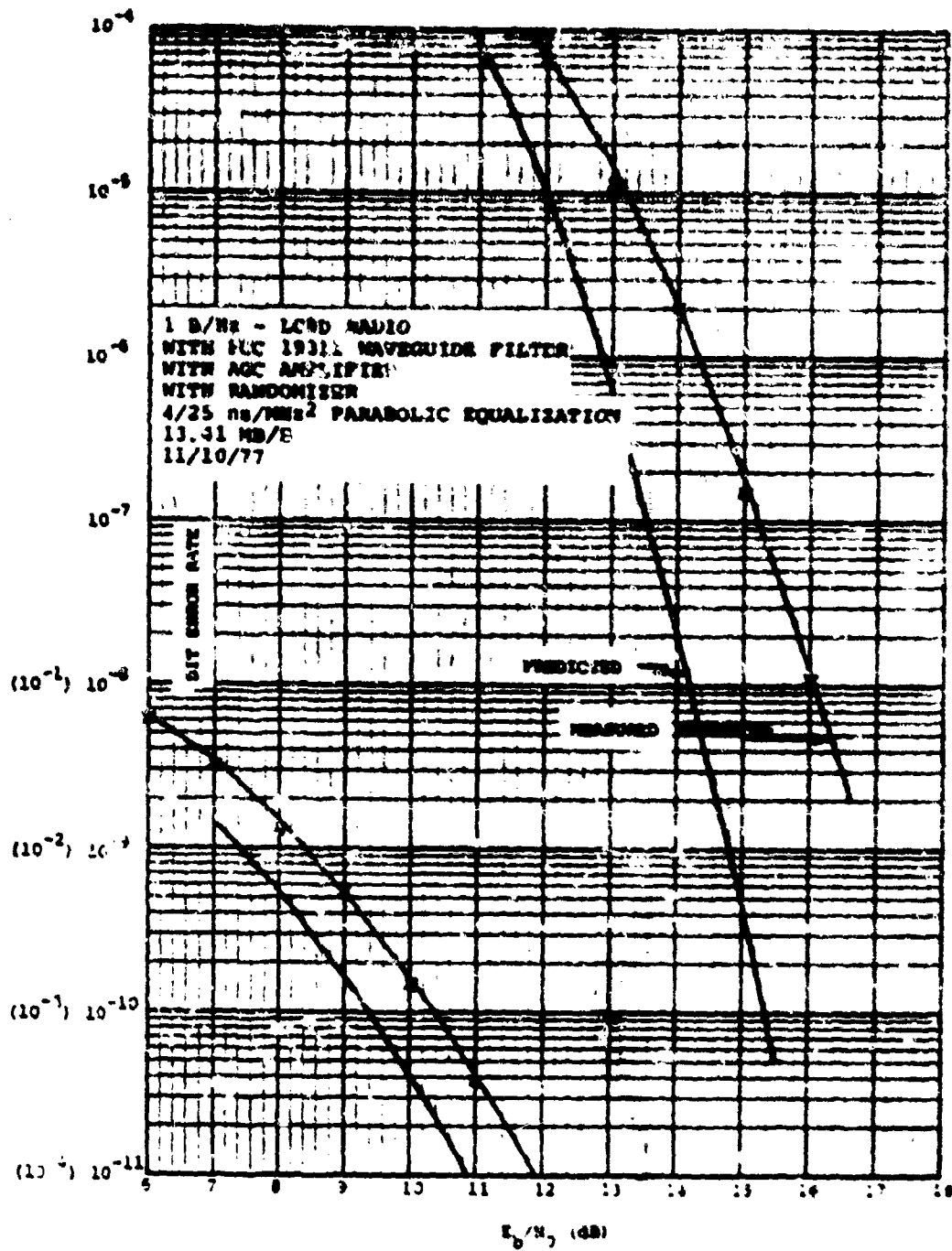

Figure 80. BER-1 B/Hz, LCBD Radio, With FCC 19311 Waveguide Filter, AGC Amplifier, Randomizer, and 4/25 ns/MHz² Parabolic Equalization

Tests were also run with radio noise as described in the previous paragraph. Figure 81 shows operation with an unequalized radio but with FCC 19311 filter, AGC, and randomizer. Figure 82 shows operation under the same conditions, but with $4/25$ ns/MHz² parabolic group delay compensation. Performance appears to be better without equalization, but the difficulty in achieving repeatable measurements with this technique can easily account for apparent discrepancy. Both curves, however, show performance exceeding the design objective of a 5×10^{-9} BER at an E_b/N_0 of 16 dB even though the randomizer was included when the data was taken.

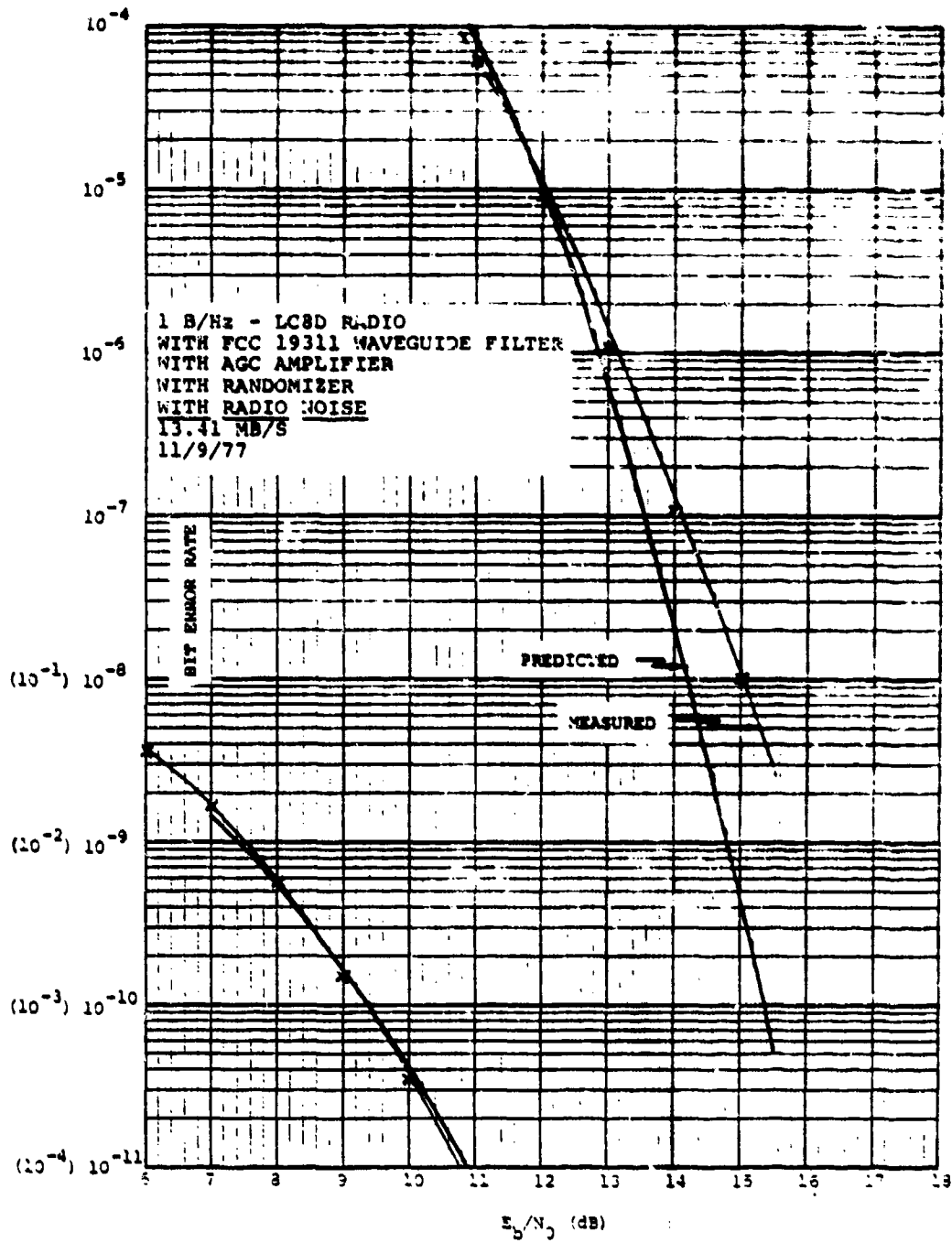

Figure 81. BER-1 B/Hz, LC8D Radio, With FCC 19311 Waveguide Filter, AGC Amplifier, Randomizer, and Radio Noise

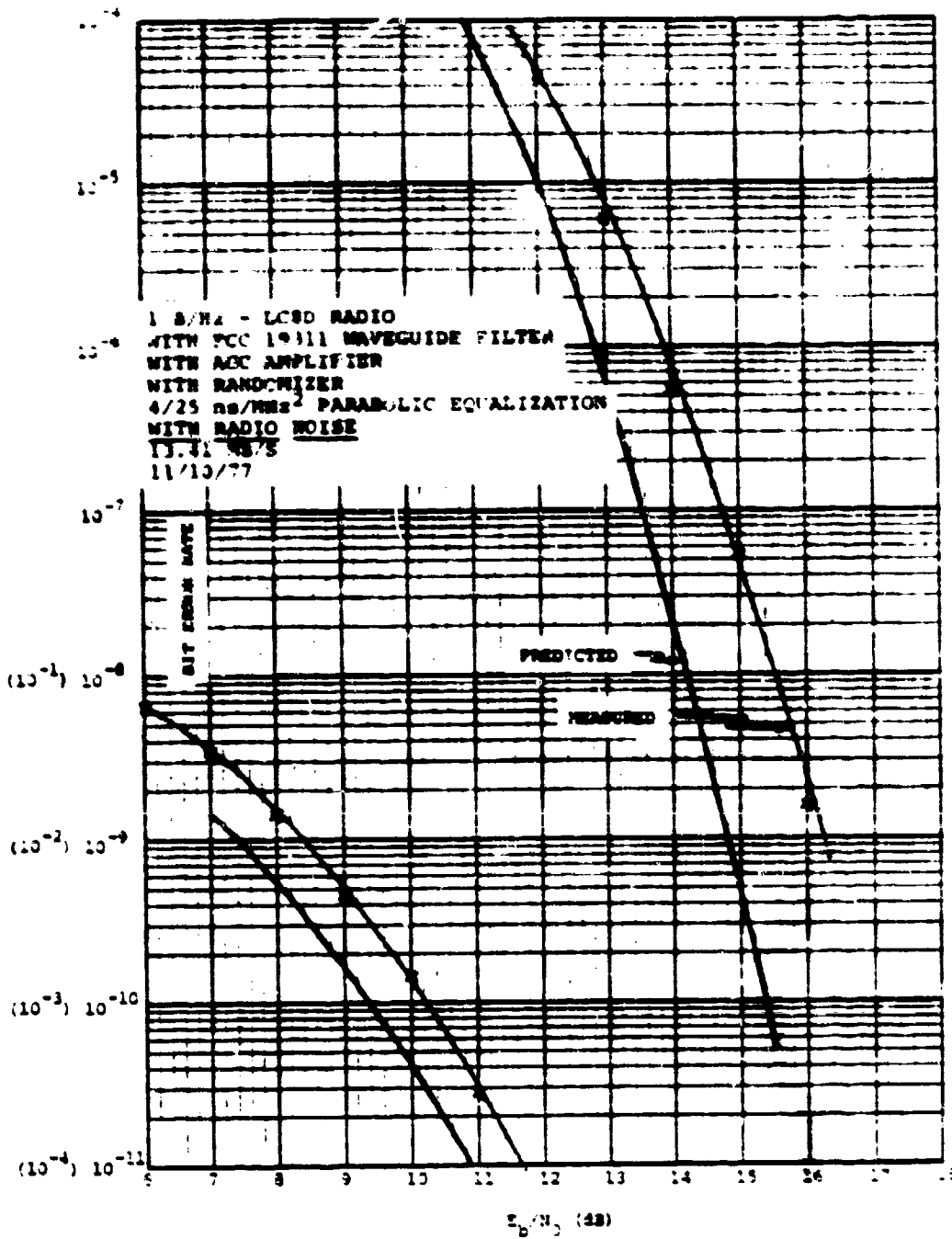

Figure 82. BER-1 B/Hz, LC8D Radio, With FCC 19311 Waveguide Filter, AGC Amplifier, Randomizer, 4/25 ns/MHz² Parabolic Equalization With Radio Noise

SECTION 5.0
CONCLUSIONS

5.0 CONCLUSIONS

A practical experimental modem suitable for actual installation in hard-limiting line-of-sight microwave radio was constructed and successfully tested. The operational limitations evident in the previously constructed breadboard (see RADC-TR-76-117) have been eliminated. Performance is stable with time and rough handling. The additional features of an input multiplexer, data randomization, dual B/Hz capability, and compliance with FCC Docket 19311 have been included with only a slight degradation in bit error rate performance.

Total compliance with the spectral requirements of FCC Docket 19311 has been shown. The acquisition design objective of 20 ns for a 20 kHz IF frequency offset was met. The design objective of a bit error rate of 5×10^{-9} or less at an E_b/N_0 of 16 dB when operating through the Philco Ford LC8D radio for a nominal 1 B/Hz spectral efficiency has been met within measurement accuracy. The randomizer/derandomizer has been shown not to degrade BER by more than a factor of three. Performance for a nominal 2 B/Hz spectral efficiency when operating through the LC8D radio misses the design objective of a bit error rate of 5×10^{-9} at an E_b/N_0 of 22 dB by less than 0.6 dB with randomizer. Allowing for a factor of three improvement without randomizer, the design goal was missed by approximately 0.2 dB.

APPENDIX A
FCC DOCKET 19311 SPECTRAL EFFICIENCY

APPENDIX A

FCC DOCKET 19311 SPECTRAL EFFICIENCY

The original goal on the previous breadboard unit was to provide a 2 B/Hz 99 percent spectral occupancy modem providing 10^{-7} error rate at $E_b/N_0 = 20$ dB and this goal was achieved. FCC Docket 19311 employed in this study embodies a more stringent requirement on the radiated spectrum than simply 99 percent bandwidth spectral occupancy for digital signalling.

The FCC Docket 19311 requirement on digital modulation techniques is stated thus:

"For operating frequencies below 15 GHz, in any 4 kHz band, the center frequency of which is removed from the assigned frequency by 50 percent or more of the authorized bandwidth: As specified by the following equation but in no event less than 50 decibels.

$$A = 35 + 0.8 (P-50) + 10 \log_{10} B$$

(Attenuation greater than 80 decibels is not required.)

Where: A = attenuation (in decibels) below mean output power level

P = percent removed from the carrier frequency

B = authorized bandwidth in MHz."

Figure A-1 and A-2 show the implications of the 19311 requirement for the 4-ary signalling schemes of interest to Broadband Modem II for nominal 1 B/Hz operation and 2 B/Hz operation respectively. Both these signalling schemes assume a 14 MHz authorized bandwidth. The mod-index 0.125 signal actually has 99 percent spectral occupancy of 2.04 B/Hz and the mod-index 0.25 has 99 percent bandwidth 1.28 B/Hz. As can be seen, the mod-index 0.125 signal has up to an 18 dB problem in the spectrum side lobes relative to the 19311 requirement and the 0.25 signal has a 15 dB problem.

The study requirement was to find the most efficient means of reducing these side lobes to meet 19311. Two techniques were investigated; IF filtering and RF Waveguide filtering (see Paragraph 2.3.1 in body of report).

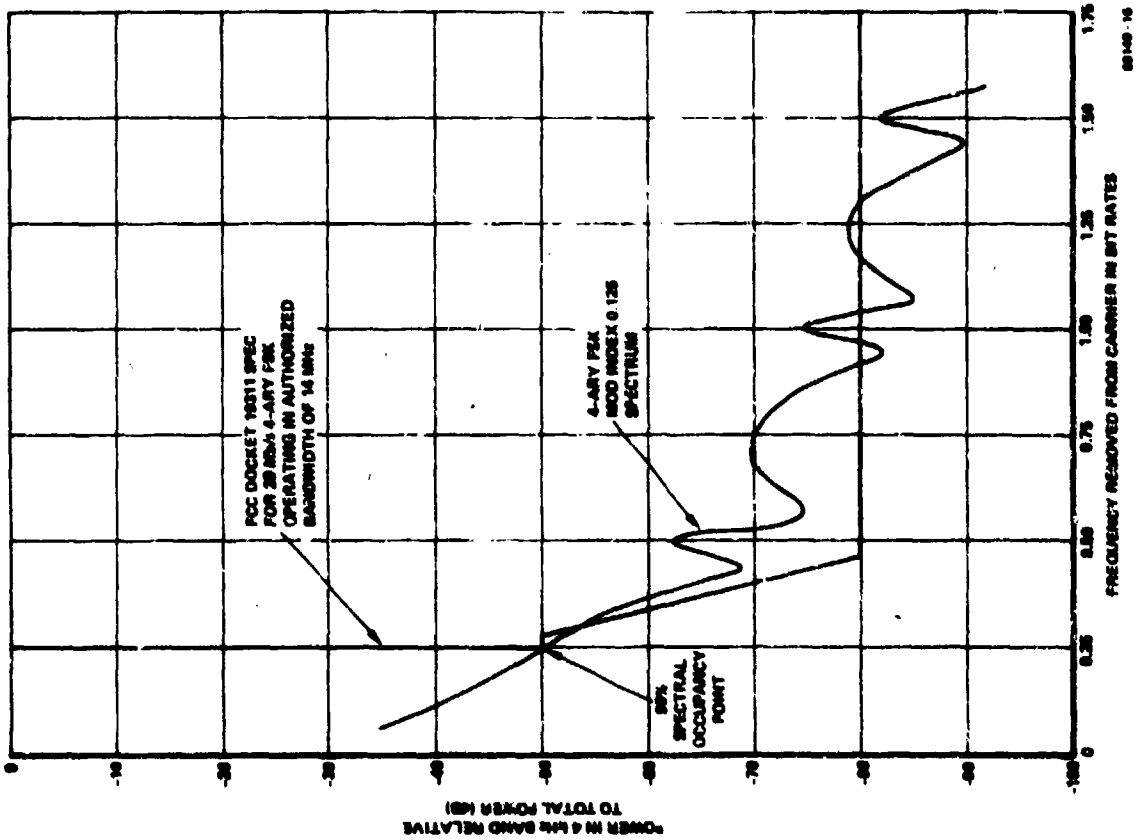

Figure A-1. Comparison of Mod Index 0.25 4-ary FSK Spectrum with 19311 Requirement

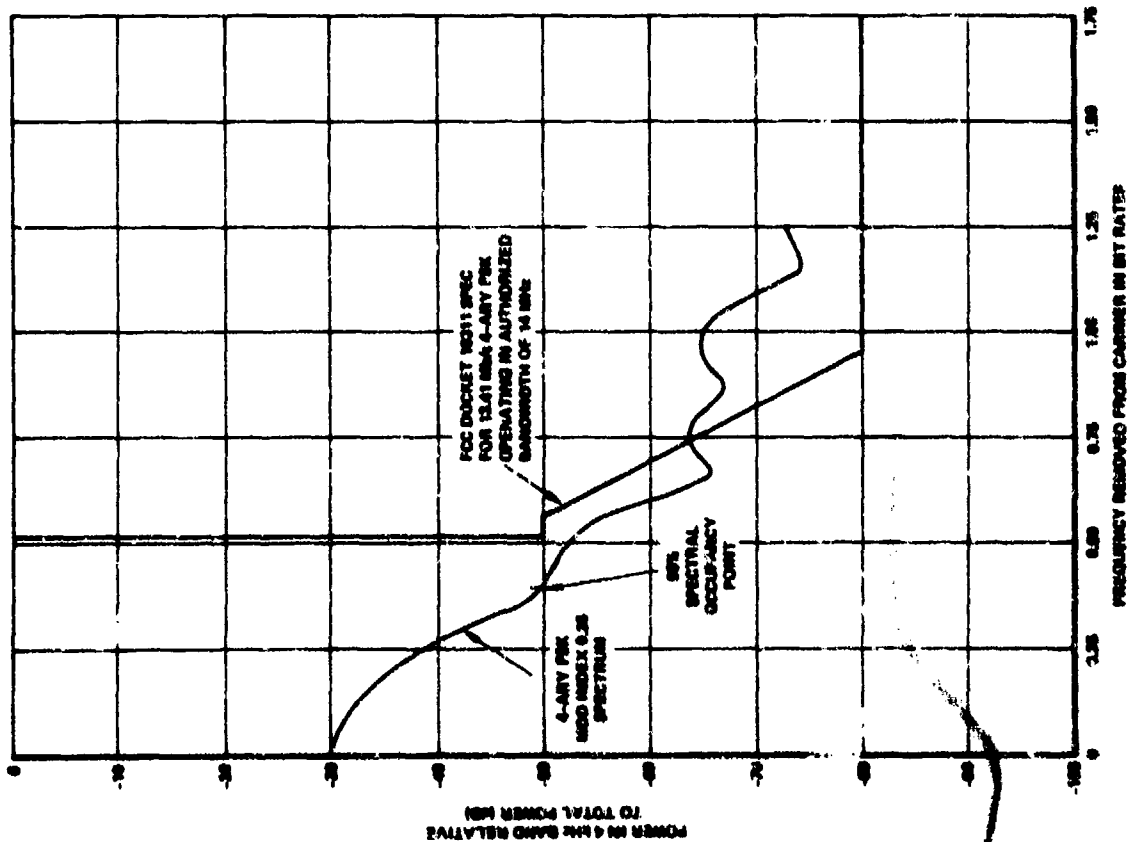

Figure A-2. Comparison of Mod Index 0.125 4-ary FSK Spectrum with 19311 Requirement

APPENDIX B
COMPUTER SIMULATION PROGRAM FOR BROADBAND MODEM II

APPENDIX B

COMPUTER SIMULATION PROGRAM FOR BROADBAND MODEM II

A FORTRAN computer program was written to evaluate various filtering approaches considered in the study phase of this program. The computer program evaluates the approaches' spectra as well as the performance with the demodulator algorithm developed on the prior Broadband Modem contract.

Figure B-1 shows the system setup the computer program can handle. Any mod-index 4-ary FSK signal can be handled. The frequency

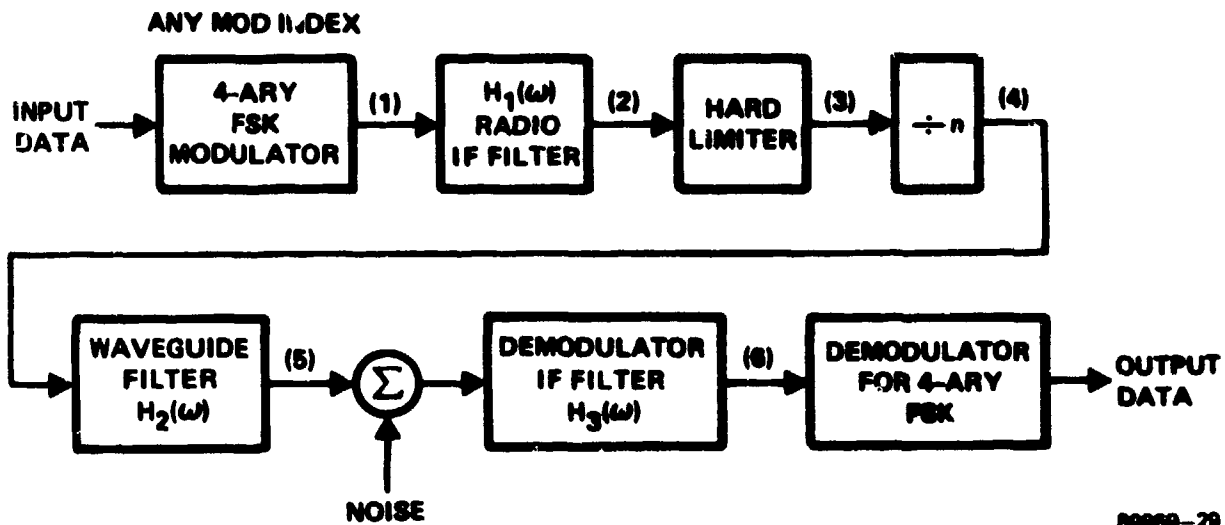

Figure B-1. Situation That Computer Program Can Handle

divide-by-n block was included in order to evaluate approaches to FCC Docket 19311 compliance through filtering mod-index 1 signals and then divide-by-8 to produce mod-index 1/8 2 B/Hz signals. No significant advantage was found for this approach and it was discarded early in the study.

Referring to Figure B-1, a PN sequence is used to generate 4-ary FSK at point (1). A Fast Fourier Transform (FFT) routine is used to

compute the transform of the sequence. This transform is filtered by H_1 (which models any radio IF filters as well as any IF spectral shaping filters) to yield the transform of the signal at point (2). An inverse FFT yields time samples of the signal at (2). These samples are hard-limited to provide time samples of the signals at point (3). The phases are divided-by-n (if necessary) to yield time samples of the signal at point (4). Again, an FFT is performed on these samples to yield Fourier transform of the signal at (4). The magnitude squared of this FFT is averaged over many sequences if IF filtering approach signal spectrum is desired. If a waveguide filter is included the FFT (4) is filtered by H_2 to yield Fourier transform of the signal at (5). Again, if spectrum at this point is desired, magnitude squared of the FFT at point (5) is averaged over many sequences. If not, the FFT at (5) is further filtered by H_3 , the demod filter to yield Fourier transform of signal at point (6). This FFT is inverse transformed to yield time samples of the signal at (6). From these time samples the phase measurements that would be made by the demodulator are computed and these phases are fed to a separate program routine for computing average symbol error rate for the sequence. The noise is modelled analytically knowing E_b/N_0 and effective noise bandwidth of the receive filter, H_3 - as opposed to Monte Carlo simulation.

This computer program was used to generate most of the results reported for Broadband Modem II. A listing of the program follows.

THIS PAGE IS BEST QUALITY PRACTICABLE
FROM COPY FURNISHED TO DDC

28 FEB 77 13.111673

PAGE 1

```
C
C THIS PROGRAM COMPUTES POWER SPECTRA OF ARBITRARY MOD-INDEX
C 4-ARY PSK BY AVERAGING FAST FOURIER TRANSFORMS.
C IT HAS CAPABILITY FOR DOING SO FOR FILTER/LIMITER COMBINATIONS
C AS WELL AS FILTER AND NO LIMITER.
C
C ALSO, PERFORMANCE OF THE PHASE DETECTOR ALGORITHM
C DEVELOPED ON RADG 2 BITS/HERTZ CONTRACT CAN BE SIMULATED.
C
C PROGRAMMER: BOB DAVIS, ATD, X5596
C
C
C
C DIMENSION WF(240)
C COMPLEX TS P(512)
C COMPLEX CS P(512),HT(512),ZVAR
C COMPLEX HR(512)
C DIMENSION ASPEC(512)
C DIMENSION WFN(512)
C DIMENSION PHODE(64)
C DIMENSION AMP(64)
C INTEGER SYMB(64)
C COMMON SYMB,PHODE,NSYM,AMP
C PI=3.14159
C IREG=15
C
C READ IGBM EQUAL 1 IF BROADBAND MODEM PERFORMANCE DESIRED
C IFSM EQUAL 0 IF SPECTRUM DESIRED
C
C READ(7,1) IGBM
C WRITE(6,901) IGBM
C 901 FORMAT(" IGBM=",I2," IGBM EQUALS 1 FOR B * PERFORMANCE")
C
C ENTER NO. OF FOURIER TRANSFORMS
C
C READ(7,1) NFT
C IF (IGBM.EQ.1) NFT=1
C WRITE(6,902) NFT
C 902 FORMAT(" NO. OF SEQUENCES TO BE FFT'D = ",I4)
C
C ENTER NO. OF 4-ARY SYMBOLS/XFORM (MUST BE POWER OF TWO)
C
C READ(7,1) NSYM
C WRITE(6,903) NSYM
C 903 FORMAT(" NO. OF SYMBOLS/SEQUENCE = ",I4)
C
C ENTER NO. OF SAMPLES/SYMBOL (MUST BE POWER OF TWO)
C
C READ(7,1) NPS
C WRITE(6,904) NPS
C 904 FORMAT(" NO. OF SAMPLES/SYMBOL FOR FFT = ",I3)
C
```

28 FEB 77 13.111673

PAGE 2

```
C      ENTER MOD/INDEX
C
      HEAD(7,1) M
      WRITE(6,905) M
905  FORMAT(' FREQ. SPACING/SYMBOL RATE (MOD INDEX) =',F8.0)
C
      ENTER FREQ. DIVIDE FACTOR
C
      HEAD(7,1) NDIV
      WRITE(6,906) NDIV
906  FORMAT(' FREQ. DIVIDE FACTOR =',I4)
C
      ENTER SYN RATE, SPECT. ANAL. BW IN SAME UNITS
C
      HEAD(7,1) SR,AHW
      WRITE(6,907) SR,AHW
907  FORMAT(' SYMBOL RATE=',F10.3,/, ' SPECTR M ANALYZER BW =',F10.3)
      FACTOR=(ABW/SR)*NSYM
      IF(FACTOR.>.1) STOP
C
      ENTER INITIAL PHASE ANGLE
C
      HEAD(7,1) TH1
      WRITE(6,908) TH1
908  FORMAT(' INITIAL PHASE ANGLE=',F10.3, 'R DIANS')
      *ENSYN*NSPS
C
      COMPUTE XMIT FILTER FREQ. RESPONSE
C
      WRITE(6,909)
909  FORMAT(//,'DATA FOR TRANSMIT FILTER FOL QW')
      DLTAF=.1/NSYM
      CALL TF(INX,DLTAF,MT)
C
      HEAD 'LIMIT' =1 IF HARD LIMITER AFTER TRANSMIT FILTER
C
      HEAD(7,1) LIMIT
      IF(LIMIT.<.1) WRITE(6,912)
      IF(LIMIT.<.1) WRITE(6,913)
912  FORMAT(//,'HARD LIMITER AFTER XMIT FILT R')
913  FORMAT(//,'NO LIMITER AFTER XMIT FILTER ')
C
      COMPUTE RECEIVE FILTER FREQ. RESPONSE
C
      WRITE(6,910)
910  FORMAT(//,'DATA FOR RECEIVE FILTER FOLL W')
      CALL TF(INX,DLTAF,MR)
C
      COMPUTE RAISER WINDOWING FUNCTION
C
      *ETA*7.
      CALL *WINDO*(INX,BETA,.6H)
```

28 FEB 77 13.111673

PAGE 3

```
C
C   COMPUTE NORMALIZING FACTOR FOR WINDOW
C
C   FNORM=0.
C   DO 60 I=1,NX
60  FNORM=FNORM+(WFN(I))**2
C
C   ZERO SPECTRUM AVGING. ARRAY
C
C   DO 12 I=1, NX
12  ASPEC(I)=0
C
C   READ TIMING DELTA IN SYMBOL TIMES
C
C   READ(7,) DT
C   WRITE(6,911) DT
911 FORMAT(,"TIMING DELTA IN SYMBOL TIMES= .F10.4)
C
C   READ XMIT FREQUENCY DETUNING IN SYMBOL ATES
C
C   READ(7,) DETUNE
C   WRITE(6,914) DETUNE
914 FORMAT(//," XMITTER DETUNING IN SYMBOL ATES=" .F10.5)
C
C   START AVGING LOOP ON XFRMS
C
C   DO 10 L=1,NFT
C   THETA=THI
C
C   START LOOP ON SYMBOLS
C
C   DO 2 J=1,NSYM
C   IF(IIBM,NE.1) GO TO 502
C
C   SHIFT 6-BIT PN REGISTER TWICE FOR 4-ARY SYMBOL
C
C   DO 1 I=1,2
C   I1=IREG/32
C   I2=MOD(IREG,2)
C   I1=I1+I2
C   I1=MOD(I1,2)
C   IREG=2*IREG+I1
C   IF(IREG.GT.63) IREG=IREG-64
C   1 CONTINUE
C   501 GO TO 503
C   502 CONTINUE
C
C   SHIFT 15-BIT PN REG. TWICE FOR 4-ARY SY BCL
C
C   DO 500 I=1,2
C   NZ=IABS(IREG/16384-IREG+2+(IREG/2))
C   IREG=2*IREG+NZ
C   IF(IREG.GT.32767) IREG=IREG-32768
```

20 FEB 77 13.111675

PAGE

999 CONTINUE
903 CONTINUE

```
C
C   DETERMINE QUANTY SYMBOL (A)
C
C   ISTRPOD(I)E(0)
C   STRPW(J)I=ISTR
C   A=STRN-1
C   IF(LINE.NVT) GO TO 99
C   IF(IJ.EQ.1) WRITE(6,9001)
9001 FORMAT(//,'SYMBOLS FOR LAST SEQUENCE OF LTP',//)
C   WRITE(6,1) J,ISTR
C   99 CONTINUE

C
C   COMPUTE SAMPLES OF LOOP/PHASE1 TO R THE STR
C
C   LIGERR(I)=STRNPS
C   WJ 3 K=1,NPS
C   PHASE=METRAC(I)A(I)N/I*PSION

C
C   ACCOUNT FOR FREQUENCY DETUNING
C
C   PHASE=PHASE-2.*PI*I*DETUNE/PSION

C
C   I=INDEX(N
C   1 CSPP(I)=COS(PI*CS(I)*PHASE1.SIN(PHASE1))

C
C   MAINTAIN CONTINUOUS PHASE--END LOOP ON VP
C   PHODE(I)=PHASE+100./PI
C   2 INETR=PHASE

C
C   COMPUTE FOURIER TRANSFORM FOR THIS SEQ.
C
C   CALL FOUR2(CSP,NR,1,1)

C
C   FILTER W/FFT FILTER
C
C   GO TO I=1,NR
C   31 CSPP(I)=CSPP(I)/NRT

C
C   INVERSE FFT
C
C   CALL FOUR2(CSP,NR,1,1)

C
C   AND LIMIT & FREQUENCY DIVIDE (IF REQ'D) CO)

C
C   I=1,NR
C   GO TO I=1,NR
C   CSPP(I)=CSPP(I)/NR
C   ZVAR=CLOS(CSP(I))
C   PH=ASIN(PAS(ZVAR))
C   IF(I.EQ.1) PH=0*PI
C   IF(I.EQ.1) GO TO 50
```

THIS PAGE IS BEST QUALITY PRACTICABLE
FROM COPY FURNISHED TO DDG

20 FEB 77 13.111673

PAGE 5

```
DLTAP=PHI-PIR
IF(DLTAP.GT.PI) INT=INT-1
IF(DLTAP.LT.(-PI)) INT=INT+1
PIR=PHI
50 PHIR=PHI+2.*PI*INT
PHI=PHI/NDIV
IF(L.NE.NFT) GO TO 100
IF(I.EQ.1) WRITE(6,444)
444 FORMAT(//,"PHASES IN DEGREES AFTER XMIT FILTER FOLLOW",//)
ISMP=ADD(I,NPS)
IF(ISMP.NE.0) GO TO 100
JEGPHI=PHI*(180./PI)
WRITE(6,900) I,DEGPHI
900 FORMAT(14,F8.2)
100 CONTINUE
IF(LIMIT.NE.1) GO TO 101
CSMP(I)=CMPLX(COS(PHI),SIN(PHI))
101 CONTINUE
C
C WEIGHT SAMPLES W/ KAISER WINDOWING FUNC ION
C AND SAVE IN "TSMP" ARRAY
C
C TSMP(I)=CSMP(I)*WFN(I)
C
C
50 CONTINUE
IF(L.NE.NFT) GO TO 81
C
C TAKE FFT
C
C CALL FOUR2(CSMP,NX,1,-1)
C
C
C FILTER W/ RECEIVE FILTER
C
C J1 70 I=1,NX
C CSMP(I)=CSMP(I)/NX
70 CSMP(I)=CSMP(I)*HR(I)
C
C ACCOUNT FOR TIMING DELTA SHIFT
C
C J2 72 I=1,NX
C IFRQ=ADD((+NX/2.-NX)/2.-1
C ANG=IFREQ*DDMES
C ZVAR=CMPLX(COS(ANG),SIN(ANG))
72 CSMP(I)=CSMP(I)*ZVAR
C
C TAKE INVERSE FFT
C
C CALL FOUR2(CSMP,NX,1,1)
C
C DETERMINE RECEIVED PHASE & PRINT
```

28 FEB 77 13.111673

PAGE 6

```
C
WRITE(6,300)
300 FORMAT(/,"PHASES FROM RECEIVE FILTER TO LOW"/)
INODE=0
DO 30 I=1,NX,NPS
ZVAR=CLOG(CSMP(I))
PSI=AIMAG(ZVAR)
PSI=PSI+(180./PI)
INODE=INODE+1
ETN=PSI-PNODE(INODE)
IF(ETN.GT.180) ETN=ETN-360.
IF(ETN.LT.(-180)) ETN=ETN+360.
PNODE(INODE)=ETN
AMP(INODE)=CABS(CSMP(I))
WRITE(6,999) INODE,PSI,SYMB(INODE),ETN,AMP(INODE)
999 FORMAT(I3,F10.3,I2,F10.3,F10.3)
30 CONTINUE
91 CONTINUE

C
C TAKE FFT OF WINDOWED TIME SAMPLES
C FROM XMIT FILTER OUTPUT
C
CALL FOUR2(TSMP,NX,1,-1)

C
C ACCUMULATE FOURIER TRANSFORM SQUARED
C
DO 15 I=1,NX
15 ASPEC(I)=ASPEC(I)+(CABS(TSMP(I)))**2

C
C END LOOP ON FFT,S
C
C IF IBBM EQUALS 1 CALL ROUTINE FOR COMPUTING SYMBOL
C ERROR RATE FOR THIS SEQUENCE
C
IF(IBBM.NE.1) GO TO 10
CALL BPMSE(1SER)
10 CONTINUE

C
C READ BEGIN,END,INCREMENT
C
5 READ(7,1) NB,NE,INC
NP = 120
ND = 1
MP = 2
XMIN = 0.0
XMAX = 120.0
YMIN = -100.0
YMAX = 0.0
DO 40 I=NB,NE,INC
A1=NFT
A2=NX
SPEC=FACTOR*ASPEC(I)/(A1*A2*FNORM)
```

THIS PAGE IS BEST QUALITY PRACTICABLE
FROM OUR ORIGINAL 35 MM

20 FEB 77 13.111675

PAGE 7

4511 1
11 1 * 120
4511 1 10. 0 428101SPC
417516.11.45111
57 007100
417516.790
900 6200AT(101.360. *SPECTRO01)
CALL SLOTHING. AF. MP. MP. U. O. HRAH. KIN. V AN. VTHIN
STOP
EAC

THIS PAGE IS BEST QUALITY PRACTICABLE
FROM COPY FURNISHED TO DDC

26 FEB 77 13.111673

PAGE 1

```
      SUBROUTINE TF(NX,DLTAF,H)
C
C     THIS SUBR. COMPUTES FILTER TRANS. FCN GIVEN POLES,ZEROS
C
      COMPLEX P(40),Z(40),WUG,PP,PZ,H(512)
      PI=3.14159265
C
      READ NO. POLES, NO. ZEROS
C
      READ(7,) NP,NZ
      WRITE(6,900) NP,NZ
900  FORMAT(" NO. POLES=",I4,"NO. ZEROS =",I )
C
      READ BANDWIDTH MULT. FACTOR FOR POLES & ZEROS
C
      READ(7,) BW
      WRITE(6,901) PW
901  FORMAT(" BANDWIDTH MULT. FACTOR FOR POL S & ZEROS =",F10.3)
C
      IF(NP.EQ.0) GO TO 30
C
      READ COMPLEX POLES
C
      WRITE(6,902)
902  FORMAT(" COMPLEX POLES FOLLOW : REAL,IM G.")
      DO 1 N=1,NP
      READ(7,) P(N)
      P(N)=BW*P(N)
      WRITE(6,) P(N)
      1  CONTINUE
      30  CONTINUE
      IF(NZ.EQ.0) GO TO 40
C
      READ COMPLEX CZEROS
C
      WRITE(6,903)
903  FORMAT(" COMPLEX ZEROS FOLLOW : REAL,IM G.")
      DO 2 N=1,NZ
      READ(7,) Z(N)
      Z(N)=BW*Z(N)
      WRITE(6,) Z(N)
      2  CONTINUE
      40  CONTINUE
C
      READ UNITY GAIN FREQ.
C
      READ(7,) WG1
      WRITE(6,904) WG1
904  FORMAT(" UNITY GAIN FREQ. =",F10.3)
      WUG=CMPLX(0.,WG1)
C
      READ BW OVER WHICH GROUP DELAY IS TO BE AVGD. TO YIELD
      TIME DELAY FOR THIS FILTER
```

28 FEB 77 13.111673

PAGE 2

```

C      READ(7,) BWGD
      WRITE(6,905) BWGD
905  FORMAT(" BW OVER WHICH GRP. DELAY AVGD. TO GET DELAY+-",F10.3)
C      COMPUTE NORMALIZING FACTOR FOR GAIN
C      PP=CMPLX(1.,0.)
      PZ=CMPLX(1.,0.)
      IF(NP.EQ.0) GO TO 4
      DO 3 N=1,NP
3     PP=PP*(WUG-P(N))
      CONTINUE
4     IF(NZ.EQ.0) GO TO 6
      DO 5 N=1,NZ
5     PZ=PZ*(WUG-Z(N))
6     GWUG=CABS(PZ/PP)
C      WUG=GAIN AT DESIGNATED FREQ.
C      COMPUTE H(K) AT APPROPRIATE FREQS.
C      ALSO REMOVE DELAY THRU FILTER
C      IREF=BWGD/DLTAF
      IF(IREF.EQ.0) IREF=1
      PHIDOT=0
      WRITE(6,200)
200  FORMAT("//," IFREQ",5X," GAIN(DB)",5X," ROUP DELAY")
      DO 20 K=1,NX
      IFREQ=MOD(K+NX/2.,NX)-NX/2-1
      W=DLTAF*IFREQ
      W=W*W
      WUG=CMPLX(0.,W)
      PP=CMPLX(1.,0.)
      PZ=CMPLX(1.,0.)
      IF(NP.EQ.0) GO TO 8
      DO 7 N=1,NP
7     PP=PP*(WUG-P(N))
      CONTINUE
8     IF(NZ.EQ.0) GO TO 10
      DO 9 N=1,NZ
9     PZ=PZ*(WUG-Z(N))
10    H(K)=(1./GWUG)*(PZ/PP)
C      DELAY CALCULATION FOLLOWS
C      IF(IFREQ.EQ.0) PHIBGN=AIMAG(CLOG(H(K)))
      IF(IFREQ.EQ.0) PSHIFT=PHIBGN
      IF(IFREQ.EQ.0) GO TO 20
      IF(ABS(IFREQ).GT.IREF) GO TO 20
      IF(IFREQ.NE.(-IREF)) GO TO 80
      PHIBGN=AIMAG(CLOG(H(K)))
  
```

THIS PAGE IS BEST QUALITY PRACTICABLE
FROM COPY FURNISHED TO DDG

28 FEB 77 13.111673

PAGE 3

```
07 TO 20
00 PHIEID=AIMAG(CLOG(H(K)))
   DELTA=PHIEID-PHIBG
   IF(DELTA.GT.PI) DELTA=DELTA-2.*PI
   IF(DELTA.LT.(-PI)) DELTA=DELTA+2.*PI
   PHIDOT=PHIDOT-DELTA/(2.*IREF-1)
   PHIRG=PHIEND
   SD=-DELTA/(2.*PI*DLTAF)
   GAIN=20.*ALOG10(CABS(H(K)))
   WRITE(6,) IFREQ,GAIN,GD
20 CONTINUE
   X=PHIDOT/(2.*PI*DLTAF)
   WRITE(6,100) X
100 FORMAT(" SYMBOLS TIMES DELAY = ",F8,2)
   PZ=CMPLX(COS(-PSHIFT),SIN(-PSHIFT))
   DO 50 K=1,NX
   IFREQ=MOD(K+NX/2,NX)-NX/2-1
   PP=CMPLX(COS(IFREQ*PHIDOT),SIN(IFREQ*PH DOT))
   H(K)=PP*PZ*H(K)
50 CONTINUE
   RETURN
   END
```

THIS PAGE IS BEST QUALITY PRACTICES
FROM COPY SUPPLIED TO DDC

28 FEB 77 13.111673

PAGE

1

```

SUBROUTINE WINDO4(MX,BETA,WFN)
  DIMENSION WFN(1024)
  N1=MX/2
  DO 1 I=1,N1
    WFN(I)=1.0
  1 CONTINUE
  F=AN/ANX-1.
  F=1.-F**2
  F=BETA*SQRT(F)
  WFN(1)=B1(F,0.001)
  RETURN
  END
```

THIS PAGE IS BEST QUALITY PRACTICABLE
FROM COPY FURNISHED TO DDC

28 FEB 77 13.111673

PAGE 1

```
FUNCTION RI(Y,ACC)
Z=(Y/2.)**2
S=1.
I=1.
I=0
15 I=I+1
H=Z/(I.**2)
T=T+H
S=S+T
25 IF (H-.95)25,25,15
S=S*ACC-T*H/(1.-R)
30 IF (S)15,15,30
RETURN
END
```

```

SUBROUTINE FOUR2(DATA,NN,NDIM,ISICM)
C THE COOLEY-TUKEY FAST FOURIER TRANSFORM IN USASI BASIC FORTRAN
DIMENSION DATA(2048),NH(3)
INQPI=6.2831853070
IF(NDIM-1)700,1,1
1 NTOT=2
  DO 2 IDEM=1,NDIM
  IF(NH(IDEM))700,700,2
2 NTOT=NTOT*NH(IDEM)
C MAIN LOOP FOR EACH DIMENSION
NP1=2
  DO 400 IDEM=1,NDIM
  N=NH(IDEM)
  NP2=NP1*N
  IF(N-1)700,400,100
C SHUFFLE DATA BY BIT REVERSAL, SINCE N=2 *K, AS THE SHUFFLING
C CAN BE DONE BY INTERCHANGE, NO WORKING ARRAY IS NEEDED
130 NP2HF=NP2/2
  J=1
  DO 160 I2=1,NP2,NP1
  IF (J-I2) 110,130,130
110 I1MAX=I2+NP1-2
  DO 120 I1=I2,I1MAX,2
  DO 120 I3=I1,NTOT,NP2
  J3=J+I3-I2
  TEMPR=DATA(I3)
  TEMPI=DATA(I3+1)
  DATA(I3)=DATA(J3)
  DATA(I3+1)=DATA(J3+1)
  DATA(J3)=TEMPR
120 DATA(J3+1)=TEMPI
130 M=NP2HF
140 IF(J-M)160,160,150
150 J=J-M
  M=M/2
  IF(M-NP1)160,140,140
160 J=J+M
C LENGTH TWO IF NEETIDDLE FACTOR W=EXP(I'S GH=2*PI*
C AND REPEAT FORT(-1)*CONJUGATE(W),
NP1W=NP1+NP1
IPAR=N
310 IF(IPAR-2)350,330,320
320 IPAR=IPAR/4
  GO TO 310
330 DO 340 I1=1,NP1,2
  DO 340 K1=I1,NTOT,NP1W
  K2=K1+NP1
  TEMPR=DATA(K2)
  TEMPI=DATA(K2+1)
  DATA(K2)=DATA(K1)-TEMPR
  DATA(K2+1)=DATA(K1+1)-TEMPI
  DATA(K1)=DATA(K1)+TEMPR
340 DATA(K1+1)=DATA(K1+1)+TEMPI
    
```

THIS PAGE IS BEST QUALITY PRACTICABLE
FROM COPY FURNISHED TO DDC

28 FEB 77 13.111675

PAGE 2

```
350 LMAX=PI
360 IF (LMAX=PI) 370,400,600
370 LMAX=MAX(PI/2, LMAX/2)
    IF (LMAX=PI) 380,400,600
380 THEI=1-1/PI*FLOAT(LMAX)/FLOAT(LMAX)
    IF (THEI=1) 390,400,600
390 THEI=THEI
400 W=COS(THETA)
    W1=SIN(THETA)
    W2=2.*W1*W1
    W3=2.*W1*W1
405 GO 570 L=PI, LMAX, PI*W
    410 W2=2.*W1*W1
        W3=2.*W1*W1
        W4=2.*W1*W1
        W5=2.*W1*W1
420 GO 530 I1=1, I1+2
    K1=IPAR(I1)
    IF (LMAX=PI) 430,430,440
430 I1=I1+1
440 K1=IPAR(I1)
450 KSTEP=K1-K2
    GO 520 K1, K1+1, NTOY, KSTEP
    K2=K1-K2
    K3=K1-K2
    IF (LMAX=PI) 460,460,480
460 U1=DATA(K1)+DATA(K2)
    U11=DATA(K1+1)+DATA(K2+1)
    U2=DATA(K3)+DATA(K4)
    U21=DATA(K3+1)+DATA(K4+1)
    U3=DATA(K1)-DATA(K2)
    U31=DATA(K1+1)-DATA(K2+1)
    U4=DATA(K3)-DATA(K4)
    U41=DATA(K3+1)-DATA(K4+1)
    U5=DATA(K1)-DATA(K2)
    U51=DATA(K1+1)-DATA(K2+1)
470 U6=DATA(K3)-DATA(K4)
    U61=DATA(K3+1)-DATA(K4+1)
    GO TO 510
475 U7=DATA(K3+1)-DATA(K4+1)
    U71=DATA(K3)-DATA(K4)
    GO TO 510
    T2=U2R+DATA(K2)-U21+DATA(K2+1)
    T3=U3R+DATA(K3)-U31+DATA(K3+1)
    T4=U4R+DATA(K4)-U41+DATA(K4+1)
    T5=U5R+DATA(K5)-U51+DATA(K5+1)
    U1R=DATA(K1)+T2R
    U11=DATA(K1+1)+T21
    U2R=U3R+T4R
    U21=U31+T41
    U3R=DATA(K1)-T2R
```

28 FEB 77 13.111673

PAGE 3

```
      U3I=DATA(K1+1)-T2I
      IF (ISIGN) 490,500,500
490  U4R=T3I-T4I
      U4I=T4R-T3R
      GO TO 510
500  U4R=T4I-T3I
      U4I=T3R-T4R
510  DATA(K1)=U1R+U2R
      DATA(K1+1)=U1I+U2I
      DATA(K2)=U3R+U4R
      DATA(K2+1)=U3I+U4I
      DATA(K3)=U1R-U2R
      DATA(K3+1)=U1I-U2I
      DATA(K4)=U3R-U4R
520  DATA(K4+1)=U3I-U4I
      KMIN=4*(KMIN-1)+1
      KDIF=KSTEP
      IF (KDIF-NP2) 450,530,530
530  CONTINUE
      M=MMAX-M
      IF (ISIGN)540,550,550
540  TEMPR=WR
      WR=-WI
      WI=-TEMPR
      GO TO 560
550  TEMPR=WR
      WR=WI
      WI=TEMPR
560  IF (I-LMAX) 565,565,410
565  TEMPR=WR
      WR=WR*WSTPR-WI+WSTPI+WR
570  WI=WI*WSTPR+TEMPR+WSTPI+WI
      WR=3-IPAR
      MMAX=MMAX+MMAX
      GO TO 360
C
C   END OF LOOP OVER EACH DIMENSION
C
600  NP1=NP2
700  RETURN
      END
```

20 FEB 77 13.111675

PAGE 1

```
SUBROUTINE NOISE(ASLN)
DIMENSION AOVE(16),LUT(16),ICM0(16),LUT( 6),ICM0T(16)
INTEGER TR(16)
INTEGER SYN(16)
DIMENSION FNO(16)
DIMENSION AMP(16)
COMMON SYN,MODE,SYN,AMP
DIMENSION T(17)
DIMENSION M(16,11)
DIMENSION MSC(14)
DIMENSION LEVEL(17)
M(1,1)=159

C
C HEAD RCVR FILTER NOISE BW IN BIT RATES
C
C HEAD(7,1) RFBW
CWRITE(16,900) RFBW
900 FORMAT(' RCVR. FILTER NOISE BW IN BIT RATES=',F10.3)
C
C HEAD ED/NO IN DB
C
C HEAD(7,1) ENNO
CWRITE(16,901) ENNO
901 FORMAT(' ED/NO IN DB =',F10.3)
C
C COMPUTE S/N RATIO OUT OF RCVR FLTR
C
C SNR=(10.0*(0.2*EDNO))/RFBW
C
C COMPUTE NOISE-CAUSED PHASE JITTER IN DEGS. RMS
C
C PJIT=(SQRT(11./12.0*SNR**3))*100./PI
CWRITE(16,902) PJIT
902 FORMAT(' NOISE CAUSED PHASE JITTER IN DEGS. RMS=',F10.3)
C
C HEAD LOOP-CAUSED SYSTEMATIC JITTER IN DEGS. RMS
C
C HEAD(7,1) SJIT
CWRITE(16,903) SJIT
903 FORMAT(' LOOP-CAUSED JITTER IN DEGS. RM =',F10.3)
C
C COMPUTE TOTAL RMS PHASE JITTER IN DEGS.
C
C TJIT=SQRT(PJIT**2+SJIT**2)
CWRITE(16,904) TJIT
904 FORMAT(' TOTAL RMS PHASE JITTER IN DEGS RMS=',F10.3)
C
C HEAD THRESHOLD & MODE SPACING IN DEGREE
C
C HEAD(7,1) TH.SPM
CWRITE(16,905) TH.SPI
905 FORMAT(' THRESHOLD SPACING IN DEGS. =',F 0.3,'MODE SPACING=',F10.3)
C
```

26 FEB 77 13.111673

PAGE 2

```
C COMPUTE LOCATION OF EACH THRESHOLD
C
T(1)=-SPN/2.-2.*TH
T(2)=-SPN/2.-TH
T(3)=-SPN/2.
T(4)=-SPN/2.+TH
T(5)=-SPN/2.+2.*TH
T(6)=SPN/2.-2.*TH
T(7)=SPN/2.-TH
T(8)=SPN/2.
T(9)=SPN/2.+TH
T(10)=SPN/2.+2.*TH

C
C HEAD NO. OF PHASES TO BE DISREGARDED ON EACH END OF SET
C COMPUTED BY FFT ROUTINE ( THIS IS TO AV ID TRANSIENTS)
C
C
C HEAD(7.) NOIS
C WRITE(6,906) NOIS
906 FORMAT(" NO. OF PHASES FROM ENDS OF FFT SEQ. DISREGARDED=",I4)

C COMPUTE TOTAL NO. OF PHASES LEFT TO BE CONSIDERED
C
C NS=NSYM-2*NOIS
C REARRANGE SEQUENCE DISREGARDING ENDS
C
C WRITE(6,907)
907 FORMAT(" SYMBOL,DEGS. ERROR TO NODE IN EQ. USED GET SER FOLLOW")
DO 1 I=1,NS
IX=I+NOIS
PNODE(I)=PNODE(IX)
SYMB(I)=SYMB(IX)
AMP(I)=AMP(IX)
WRITE(6,) SYMB(I),PNODE(I),AMP(I)
1 CONTINUE

C CALCULATE PROR. OF EACH OF 11 REGIONS F R EACH SYMBOL
C
C
DO 2 N=1,NS
V=(T(1)-PNODE(N))/TJIT
V=AMP(N)*V
P(N,1)=1.-Q(V)
V=(T(10)-PNODE(N))/TJIT
V=AMP(N)*V
P(N,11)=Q(V)
DO 3 L=2,10
L1=L-1
VU=(T(L)-PNODE(N))/TJIT
VU=AMP(N)*VU
VL=(T(L1)-PNODE(N))/TJIT
VL=AMP(N)*VL
3 P(N,L)=Q(VL)-Q(VU)
2 CONTINUE
```

THIS PAGE IS BEST QUALITY PRINTOUT
FROM COPY FURNISHED TO DDG

08 FEB 77 15.111673

PAGE

4

```
07 21 J#1,ITD
LEV=LEVEL(J)
IF(LEV.EQ.11) MOVE(J)=1
IF(LEV.EQ.6) AND(LEV.LT.11) MOVE(J)=
IF(LEV.LT.6) MOVE(J)=1
21 CONTINUE
```

C TENTATIVE FREQUENCY DECISIONS
C TENTATIVE FREQ. = LINE BETWEEN 2 BOTTOM RETAINED PHASES
C

```
07 22 J#2,ITD
J#2=1
JST="SUPER"
IF(J#1ST="B" JST#1)+=0/J#1)+MOVE(J)
22 CONTINUE
```

C FIRST PASS, UPPER/LOWER DECISIONS, CHANGE "IND" BITS
C

```
07 23 J#3,ITD
J#3=1
J#3=2
LUIJ2=0
ICMGJ2=0
LEV=LEVEL(J)
IF(LEV.EQ.11) OR(LEV.EQ.6) OR(LEV.EQ.11) GO TO 23
IT#TF(J)-TF(J)
IF(MOVE(J).EQ.0) LCOMP#0+IT#
IF(MOVE(J).EQ.(-1)) LCOMP#0+IT#
IF(LEV.LT.LCOMP) LUIJ2=1
IF(LEV.EQ.LCOMP) ICMGJ2=1
L#LCOMP+1
IF(LEV.EQ.L#1) ICMGJ2=1
23 CONTINUE
```

C L#1) THRU LUIJ2-2) CONTAIN UPPER/LOWER DECISIONS
C ICMGJ2) THRU ICMGJ2-2) CONTAIN "CHANGE "IND" BITS
C

```
L#ICMGJ2-1)+ICMGJ2-2)
IF(L#1) GO TO 30
L#LUIJ2-2)
L#LUIJ2-1)
L#L#1
L#L#1
23 TO 31
SUCCESSIVE PASSES FOLLOW
```

```
07 24 J#4,ITD
J#4=1
07 25 J#5,ITD
J#5=1
IF(ICMGJ2).EQ.1) GO TO 26
L#LUIJ2-1)
L#LUIJ2-2) ICMGJ2)
```

28 FEB 77 13.111673

PAGE 5

```
GO TO 25
26 J2=J+2
   IOLTA=LU(J)+LU(J2)-1
   LUT(J)=LU(J1)
   ICHGT(J)=ICHGT(J1)
   IF((LUT(J).EQ.0).AND.(IOLTA.EQ.(-1))) L T(J)=1
   IF((LUT(J).EQ.1).AND.(IOLTA.EQ.1)) LUT(J)=0
25 CONTINUE
   JO 27 J=1,NDIM
   LU(J)=LUT(J)
27 ICHG(J)=ICHGT(J)
24 CONTINUE
```

C
C FINAL FREQUENCY DECISION FOLLOWS
C

```
31 I4F=NREF+NOP+2
   I7FR=NOP+2
   FF=TF(I7FR)+LU(2)-LU(1)
   IF(FF.GT.3) FF=3
   IF(FF.LT.0) FF=0
   ISREF=SYMB(I7F)
   IERROR=0
   IF(FF.NE.ISREF) IERROR=1
```

C
C AT THIS POINT "IERROR" = 0 IF NO ERROR FOR ISOLATED SEQUENCE
C "IERROR" = 1 IF A FREQUENCY ERROR IS MADE
C

```
IF(IERROR.EQ.1) SER=SER+IP
```

C
C END OF DECODE ROUTINE
C
C
C

```
32 CONTINUE
   ISO=ISO+1
   JREF=NTD
5   LEVEL(JREF)=LEVEL(JREF)+2
   LTEST=LEVEL(JREF)
   IF(LTEST.LE.11) GO TO 4
   LEVEL(JREF)=1
   JREF=JREF-1
   IF(JREF.GT.0) GO TO 5
6   JREF=NREF+1
   ASER=SER/NREF
   WRITE(6,910) JREF,ISO,ASER
910 FORMAT(" SYMB. # DECODED=",I3,"NO. SEGS ISOLATED=",I8,"AVG. SER S
   IO FAR=",E10.2)
   ISO=0
   IF(NREF.GT.NRENU) GO TO 7
   JREF=1
   PSEQ(1)=1.
   GO TO 4
7   CONTINUE
```

**THIS PAGE IS BEST QUALITY PRACTICES
FROM COPY SUBMITTED TO EPA**

NO. 100 00 11.10.1979

PAGE 6

FOR THE USE OF THE PUBLIC AT THIS OFFICE

REPLY
BY

THIS PAGE IS BEST QUALITY PRACTICABLE
FROM COPY FURNISHED TO DDC

28 FEB 77 15.111673

PAGE 1

```
FUNCTION B(X)
AX=ABS(X)
IF (AX.GT.8) P=0.
IF (AX.GT.8) GO TO 10
T=1.0/(1.0+.2316419*AX)
P=0.3989423*EXP(-X*X/2.0)
P=P*T*(((1.330274*T-1.821256)*T+1.7714 8)*T-
10.365638)*T+.5194615)
10 IF(X) 20,30,30
20 P=1.0-P
30 W=P
RETURN
END
```

APPENDIX C

TEST PLAN

APPENDIX C

TEST PLAN

1.0 SCOPE

This plan describes a test program for the Broadband Digital Modem. The tests will be conducted at PADC and at HARRIS Electronic Systems Division (Harris ESD) in Melbourne, Florida.

2.0 OBJECTIVE

The overall objective is to characterize the critical performance parameters of the modem. Specific tests include:

- a. Spectral Efficiency
- b. BER versus E_b/N_0
- c. Acquisition

3.0 MODEM DESCRIPTION

The Broadband Modem II was developed to improve the available bandwidth efficiency in digital Line-of-Sight microwave systems. The primary performance objective is a 5×10^{-9} BER at an E_b/N_0 of 22 dB at a data rate of 26.82 Mb/s. The unit provides a bandwidth efficiency of ≥ 1 B/Hz of RF bandwidth and interfaces at 70 MHz with hard limiting radio systems. The modem is also configured to operate at a bandwidth efficiency of 1 B/Hz of RF bandwidth. The primary performance objective for this mode of operation is 5×10^{-9} BER at an E_b/N_0 of 16 dB at a data rate of 13.41 Mb/s.

3.1 Technique Description

The modulation technique is continuous phase, 4-ary FSK with a modulation index of 1/3 (i.e., the four tones are spaced at 1/8th the

symbol rate frequency intervals). The modulator is shown conceptually in Figure C-1. The demodulator employs coherent detection and multisymbol observation techniques to achieve the required performance. The demodulator is shown in Figure C-2.

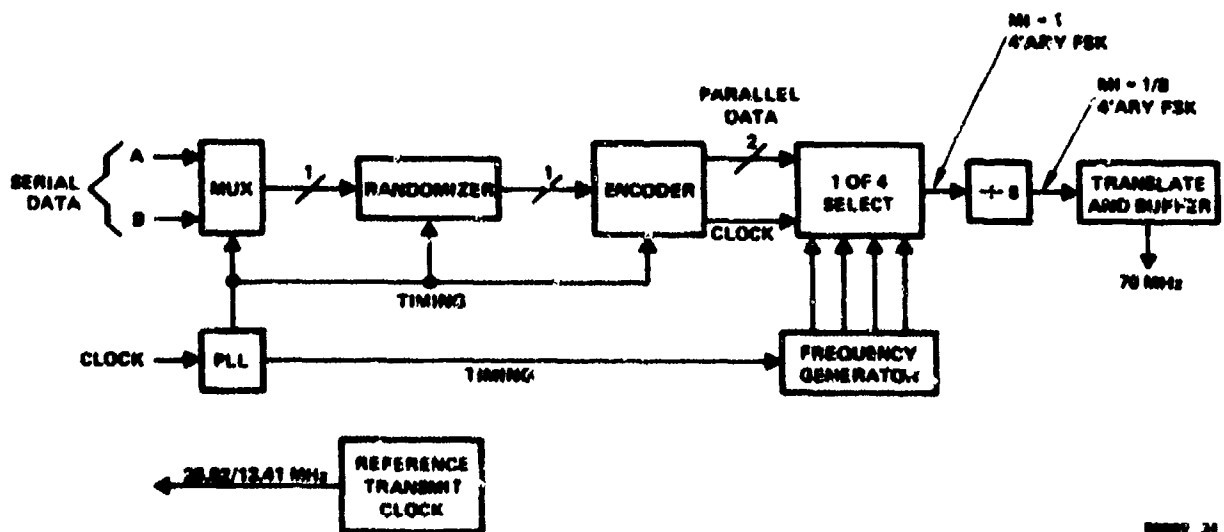

Figure C-1. Modulator Conceptual Block Diagram

3.2 Hardware Description.

The modulator and demodulator are individually packaged in 19-inch chassis with integral power supplies. On the transmit side, the modulator provides a transmit clock and accepts either a single bit rate data stream and associated timing or 2-1/2 bit rate data streams to be MIXed together and associated timing. The transmit clock automatically adjusts rate for the chosen mode of operation. All digital interfaces are 75-ohm, unbalanced, bipolar interfaces. The modulated, 70 MHz carrier is outputted at +1 dBm level to the radio. The demodulator accepts a +1 dBm, 70 MHz signal from the radio and outputs data and synchronous timing. The modulator's 20-stage randomizer can be configured to operate as a

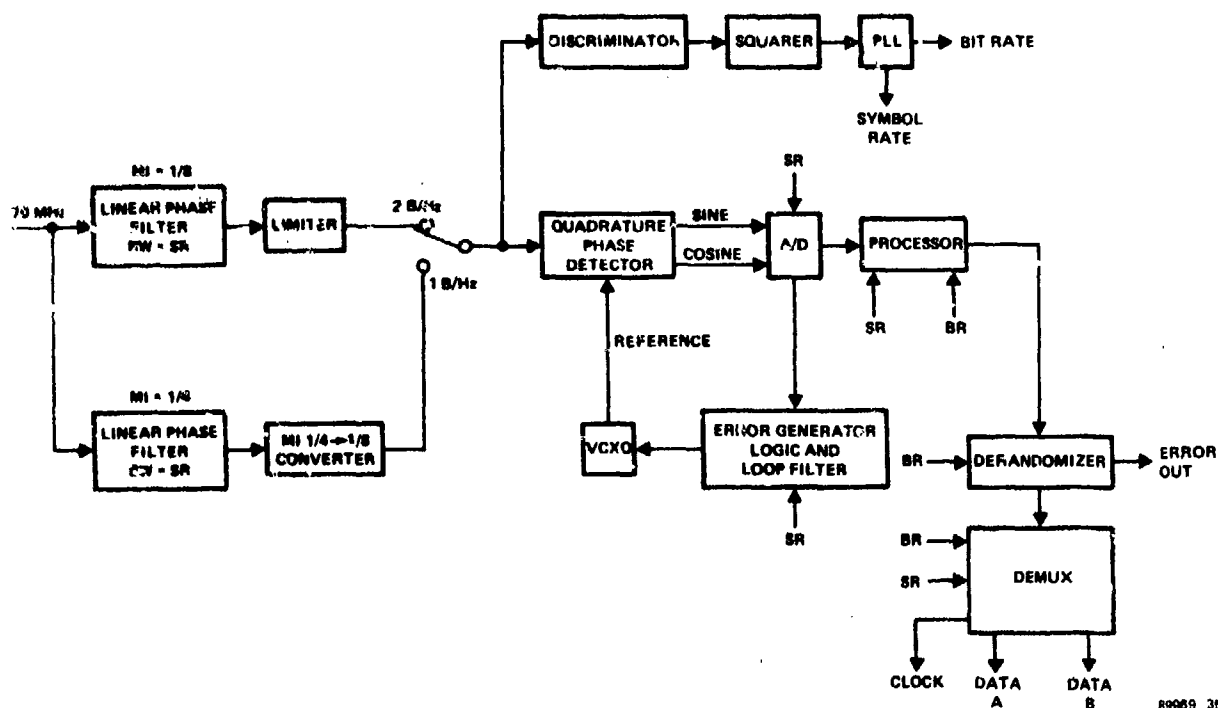

Figure C-2. Demodulator Conceptual Block Diagram

pseudorandom sequence generator which is decoded in the demodulator to provide a bit error output. This may be monitored by an external frequency counter to determine BER without the use of external data generators and error detectors. The use of the randomizer/derandomizer degrades BER by a factor of three. This is reflected in the bit error output on the demodulator. For convenience, BER tests may also be performed with the

randomizer and derandomizer by-passed. This may be accomplished by a simple internal wiring change in both boxes. An external data source and error counter are then required.

4.0 TEST PROGRAM

The test program includes tests at Harris ESD in Melbourne, Florida, and at RADC. The in-plant tests are designed to provide a performance baseline from which to interpret results from the later radio and link tests and to verify the characteristics of various internal parameters. Most of these tests are performed with the modem looped back at 70 MHz with additive thermal noise. In order to meet the spectral efficiency requirements of FCC Docket 19311 an RF waveguide filter at 8.075 GHz is to be employed. Although final performance verification of this technique must await installation of the filter in the LC8D radio, initial tests at Harris employing an upconversion from 70 MHz to 8.075 GHz and back down to 70 MHz with thermal noise added to the IF input to the demodulator will be performed. The RADC tests include both back-to-back tests with the radio simulator and link tests utilizing the Stockbridge radio.

4.1 In-Plant Tests

The test configuration for in-plant tests is shown in Figure C-3. A diagram of the up/downconverter for waveguide filter tests is shown in Figure C-4.

4.1.1 Spectral Efficiency

The objective of this test is to demonstrate that the output of the modulator upconverted to 8.075 GHz and filtered with the supplied waveguide filter meets FCC Docket 19311 requirements. A computer generated spectral mask, plotting energy in 4 kHz bandwidth versus offset frequency from center, is available. The actual transmit spectrum is plotted using a spectrum analyzer set for a 3 kHz IF bandwidth. The absolute level is calibrated by observing the difference in spectral height at center frequency between an unmodulated tone and a randomly modulated signal. If

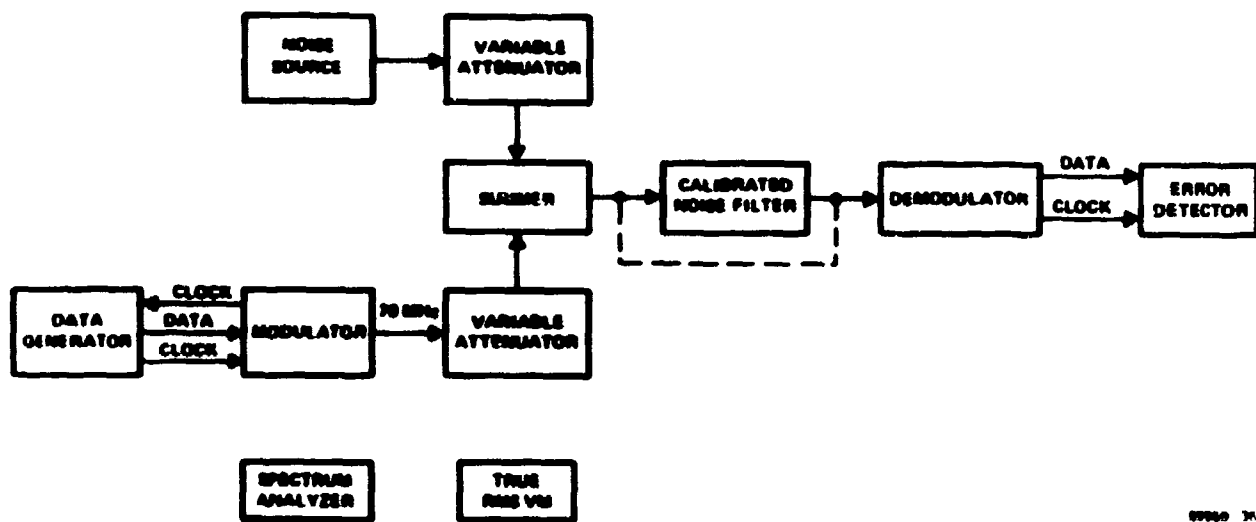

Figure C-3. In-Plant Test Configuration

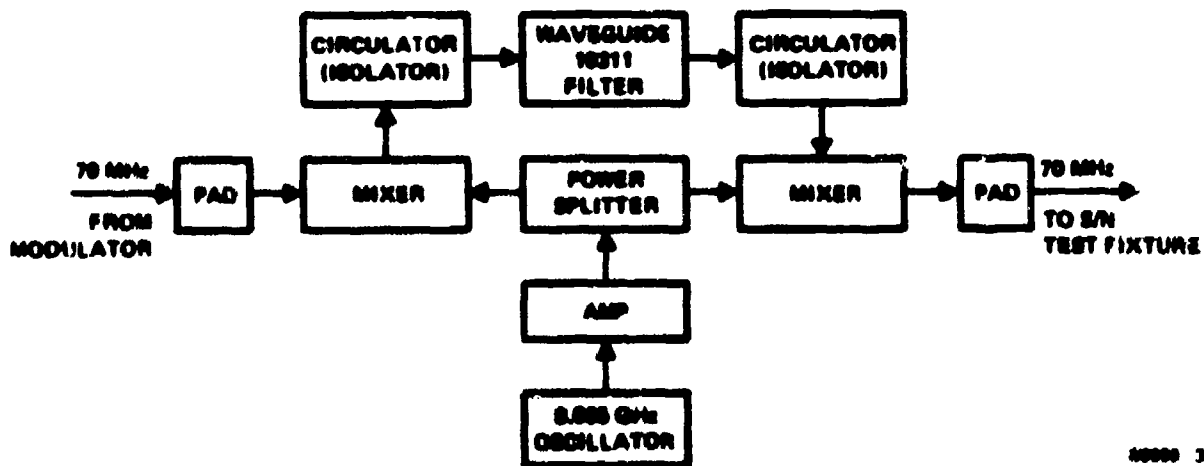

Figure C-4. Up/Downconverter for In-Plant Waveguide Filter Tests

the plotted transmitter spectrum falls on or below the mask, the FCC 19311 requirements will have been met. The test is performed for both 1 B/Hz and 2 B/Hz operation.

4.1.2 E_b/N_0 Calibration

The calibration of E_b/N_0 is accomplished directly at the demodulator input. The signal attenuator is set at 120 dB and the noise power is measured using a filter with a known noise bandwidth. The noise bandwidth is established by graphical integration techniques. The noise attenuator is then set at 120 dB and the signal power is adjusted to give the same meter reading as the noise power did previously. The noise attenuator is then restored to its original position, establishing a 0 dB SNR in the filter bandwidth. E_b/N_0 is then determined by adding a correction factor that is equal to $10 \log \frac{NBW}{BR}$ where NBW is the measured noise bandwidth of the calibrated filter and BR is the bit rate. The desired E_b/N_0 is obtained by adjusting the attenuator setting.

4.1.3 Bit Error Rate Versus E_b/N_0

The objective of this test is to characterize the BER performance of the modem over the range from 10^{-2} to 10^{-9} as a function of E_b/N_0 . The test setup is calibrated as in Paragraph 4.1.2. The attenuator is adjusted to provide an E_b/N_0 of 10 dB. The error detector is adjusted to provide an error sample of at least 100 events. The indicated error rate is recorded on seven cycle semilog paper. The attenuator is adjusted to provide an E_b/N_0 of 11 dB and the indicated error rate is recorded. This process is repeated until an E_b/N_0 of 22 dB is reached. The test is performed with the modulator and demodulator back-to-back and also with the up/downconverter and RF filter. Results are obtained for both 2 B/Hz and 1 B/Hz operation.

4.1.4 Acquisition

The objective of this test is to determine the time interval required for the demodulator to acquire synchronization following the

application of IF signal. The design objective is 20 ms at an E_b/N_0 corresponding to a $1 \cdot 10^{-7}$ BER with a frequency offset of 20 kHz. A diagram of the test setup is shown in Figure C-5. The 70 MHz IF is offset by replacing the modulator's internal 97.658125 MHz LO with a frequency synthesizer or stabilized oscillator. Varying the frequency of this source will directly vary the center frequency of the modulator output. The IF signal plus noise is gated on with a digitally controlled switch. The switch control signal also triggers an oscilloscope which monitors the error output of the demodulator. The time of transition from a 50 percent error rate to one of $1 \cdot 10^{-7}$ can be observed on the scope and the time interval noted. The test is run with both the 2 B/Hz operation and 1 B/Hz operation.

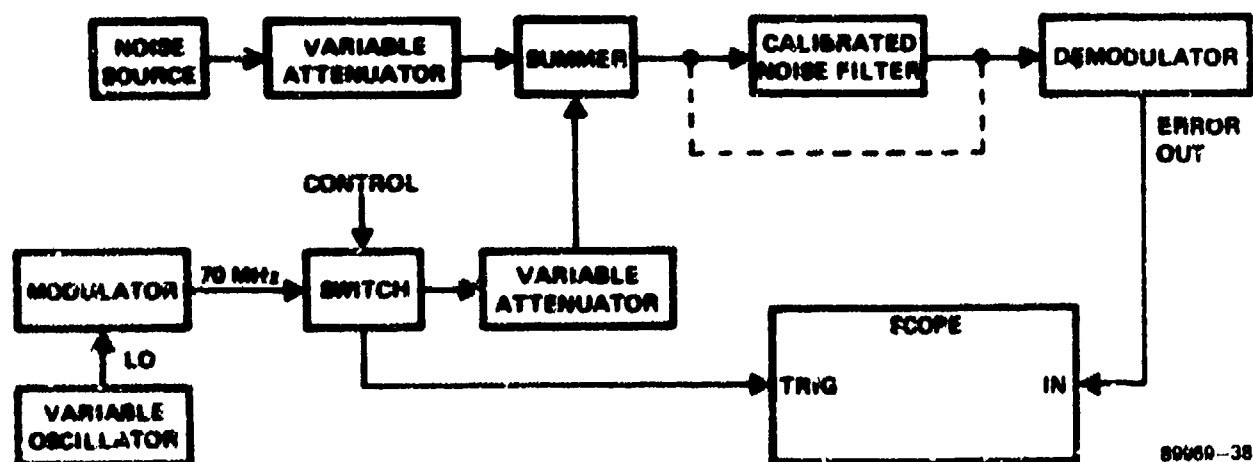
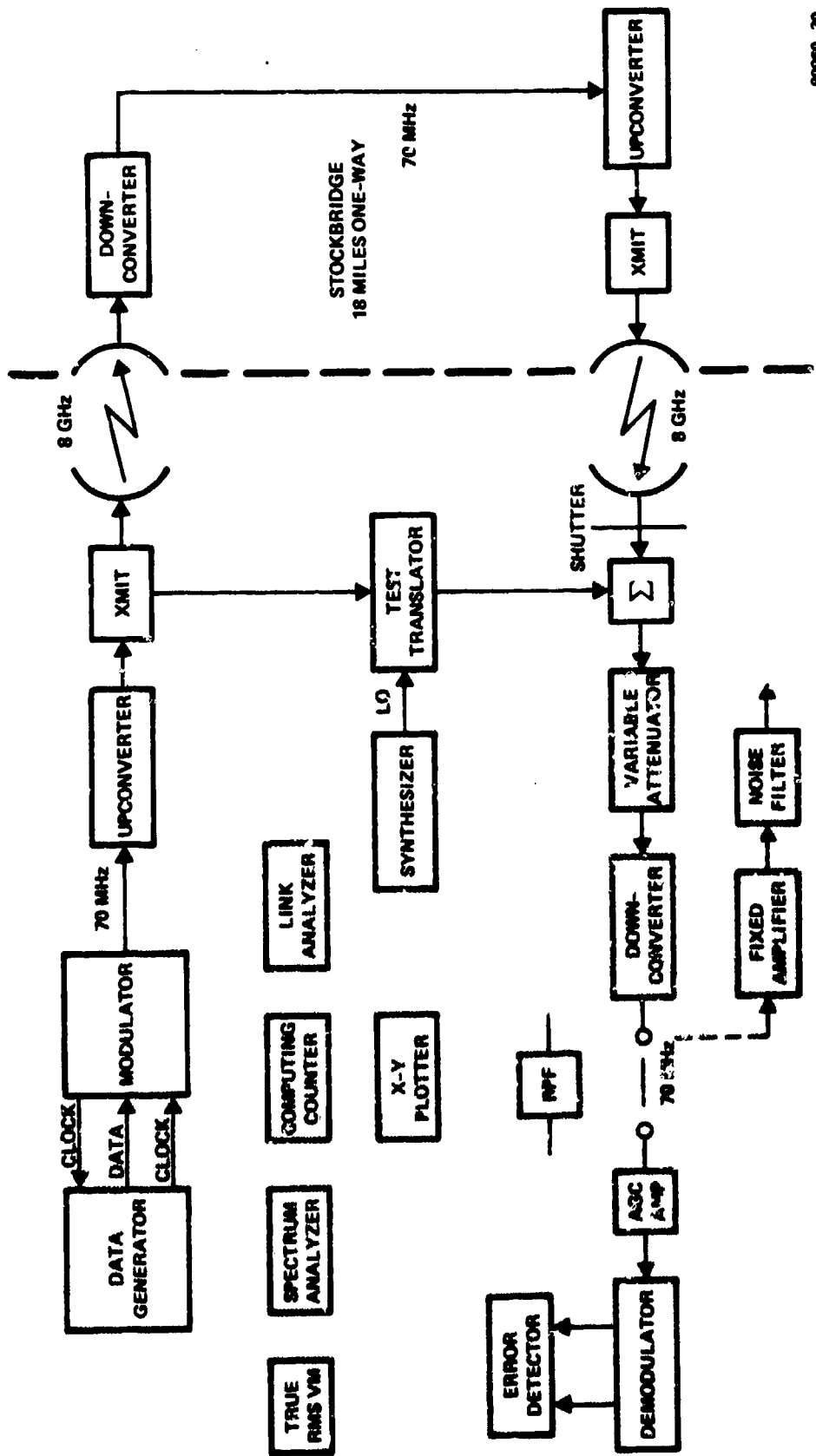

Figure C-5. Acquisition Test Set Configuration

4.2 RADC Tests

The test configuration for the RADC tests is shown in Figure C-6. The overall objective of these tests is to characterize the modem performance when interfaced with the LC8D radio. The link analyzer is used to document the amplitude and delay characteristics of the test configuration.



80980-30

Figure C-6. RADAR Test Configuration

4.2.1 Spectral Occupancy

The objective of this test is to determine the degree to which the transmitted spectrum conforms to the requirements of FCC 19311. The modulator output is applied to the upconverter and the 8.075 GHz spectrum filtered with the waveguide filter is plotted with the spectrum analyzer and X-Y plotter. Results may be compared with the 70 MHz spectrum to determine the effects of the filter.

4.2.2 E_b/N_0 Calibration

The calibration of E_b/N_0 is accomplished directly at the demodulator input. A fixed gain amplifier is required outboard to the radio to provide the power level necessary for the HP 431C meter. With the waveguide shutter closed and the simulator configured for loop back at 8 GHz, the downconverter (D/C) noise is read through the calibrated filter with the receive attenuator set at 90 dB. The attenuator is then decreased until the meter reading increases by 3 dB which indicates the SNR in the calibrated filter is 0 dB. As described in Paragraph 4.1.2, E_b/N_0 is $0 + K$ dB at this point, where K is the correction factor for the noise filter. The desired E_b/N_0 is obtained by adjusting the attenuator setting.

4.2.3 Bit Error Rate Versus E_b/N_0

The objective of this test is to characterize the BER and the recovered clock jitter performance of the modem as a function of E_b/N_0 . Tests are run with the simulator looped at 8 GHz and over the link to Stockbridge and back. The test setup is calibrated as described in Paragraph 4.2.2. The receive attenuator is used to adjust E_b/N_0 in 1 dB steps. The BER is recorded at each step to produce a complete 7 cycle graph of performance as a function of E_b/N_0 . The computing counter is used to measure recovered clock jitter as appropriate. Tests are run with and without the FCC 19311 waveguide filter and for both 2 B/Mz and 1 B/Mz operation.

5.0 TEST DATA EVALUATION

The test results will be analyzed and provided in the Final Report