

AD-A053 418

SCHOOL OF AEROSPACE MEDICINE BROOKS AFB TEX
HYDROGEN GAS STANDARDS USING LASER RAMAN SPECTROSCOPY. (U)
JAN 78 D M THOMAS

F/6 7/4

UNCLASSIFIED

SAM-TR-78-2

NL

1 of 1
AD
A053418

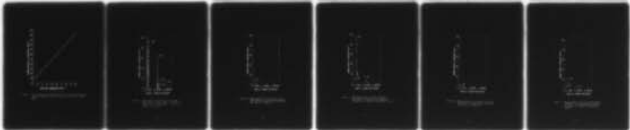
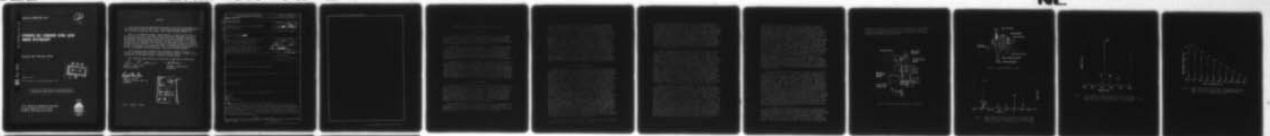

END
DATE
FILMED
6 JAN 78
DDC

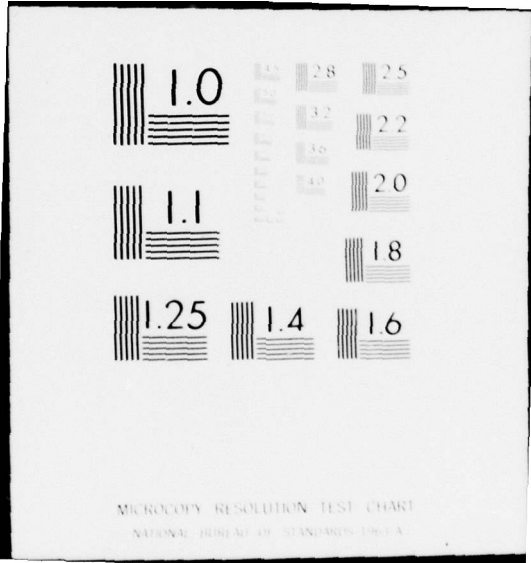

MICROCOPY RESOLUTION TEST CHART
NATIONAL BUREAU OF STANDARDS-1963-A

AD A 053418

DDC FILE COPY

Report SAM-TR-78-2

2
R

HYDROGEN GAS STANDARDS USING LASER RAMAN SPECTROSCOPY

Dwaine M. Thomas, Ph.D.

January 1978

Final Report for Period March-April 1977

DDC
PROFILE
MAY 3 1978
RESOLVED
E

Approved for public release; distribution unlimited.

USAF SCHOOL OF AEROSPACE MEDICINE
Aerospace Medical Division (AFSC)
Brooks Air Force Base, Texas 78235



NOTICES

This final report was submitted by personnel of the Crew Environments Branch, Crew Technology Division, USAF School of Aerospace Medicine, Aerospace Medical Division, AFSC, Brooks Air Force Base, Texas, under job order 7930-11-37.

When U.S. Government drawings, specifications, or other data are used for any purpose other than a definitely related Government procurement operation, the Government thereby incurs no responsibility nor any obligation whatsoever; and the fact that the Government may have formulated, furnished, or in any way supplied the said drawings, specifications, or other data is not to be regarded by implication or otherwise, as in any manner licensing the holder or any other person or corporation, or conveying any rights or permission to manufacture, use, or sell any patented invention that may in any way be related thereto.

This report has been reviewed by the Information Office (OI) and is releasable to the National Technical Information Service (NTIS). At NTIS, it will be available to the general public, including foreign nations.

This technical report has been reviewed and is approved for publication.

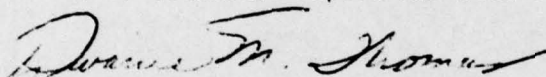

DWAINE M. THOMAS, Ph.D.
Project Scientist

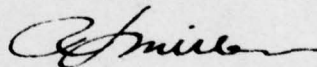

RICHARD L. MILLER, Ph.D.
Supervisor

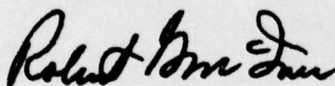

ROBERT G. MCIVER
Brigadier General, USAF, MC
Commander

ACCESSION for	
DTIC	White Section <input checked="" type="checkbox"/>
DOC	Buff Section <input type="checkbox"/>
UNANNOUNCED	<input type="checkbox"/>
JUSTIFICATION	
DISTRIBUTION/AVAILABILITY COD.	
Dist.	AVAIL. and/or SPECIAL
A	

Editor: MARION E. GREEN

REPORT DOCUMENTATION PAGE		READ INSTRUCTIONS BEFORE COMPLETING FORM	
1. REPORT NUMBER 14 SAM-TR-78-2 ✓	2. GOVT ACCESSION NO.	3. RECIPIENT'S CATALOG NUMBER	
4. TITLE (and Subtitle) 6 HYDROGEN GAS STANDARDS USING LASER RAMAN SPECTROSCOPY.	5. TYPE OF REPORT & PERIOD COVERED 9 Final Report. March - April 1977		
	6. PERFORMING ORG. REPORT NUMBER		
7. AUTHOR(s) 10 Dwaine M. Thomas Ph.D.	8. CONTRACT OR GRANT NUMBER(s)		
9. PERFORMING ORGANIZATION NAME AND ADDRESS USAF School of Aerospace Medicine (VNL) Aerospace Medical Division (AFSC) Brooks Air Force Base, Texas 78235		10. PROGRAM ELEMENT, PROJECT, TASK AREA & WORK UNIT NUMBERS 62202F 26 7930-11-37 17 11	
11. CONTROLLING OFFICE NAME AND ADDRESS USAF School of Aerospace Medicine (VNL) Aerospace Medical Division (AFSC) Brooks Air Force Base, Texas 78235		12. REPORT DATE 19 January 1978	
14. MONITORING AGENCY NAME & ADDRESS (if different from Controlling Office)		13. NUMBER OF PAGES 14 12 17 p.	
		15. SECURITY CLASS. (of this report) Unclassified	
		15a. DECLASSIFICATION/DOWNGRADING SCHEDULE	
16. DISTRIBUTION STATEMENT (of this Report) Approved for public release; distribution unlimited.			
17. DISTRIBUTION STATEMENT (of the abstract entered in Block 20, if different from Report)			
18. SUPPLEMENTARY NOTES			
19. KEY WORDS (Continue on reverse side if necessary and identify by block number) Hydrogen Raman Raman Spectroscopy			
20. ABSTRACT (Continue on reverse side if necessary and identify by block number) The Raman spectra for various concentrations of hydrogen (H ₂) have been recorded using a multipass gas technique. The intensities were correlated with the concentrations in order to give values which could be used in calibration of H ₂ -detecting instruments. The results indicated the concentration values obtained by Raman were accurate and could be used as another source for standards in calibrating instrumentation. 317 P.P.P.			

SECURITY CLASSIFICATION OF THIS PAGE(When Data Entered)



SECURITY CLASSIFICATION OF THIS PAGE(When Data Entered)

HYDROGEN GAS STANDARDS USING LASER RAMAN SPECTROSCOPY

INTRODUCTION

Gas standards may be prepared gravimetrically or by pressure-volume-temperature (PVT) methods. Instruments designed for the detection and quantitation of these gases must be tested for instrument reliability and eventually for calibration. As a check on both PVT techniques and instrument reliability, a third approach is desirable.

For the detection of diatomic molecules, such as hydrogen (H_2), Raman spectroscopy offers several distinct advantages over other instrumental techniques. Sample preparation is quite simple. A given quantity of gas can be made up (100%) to a certain pressure, and the spectrum measured. Dilutions of this sample and subsequent spectra allow for correlation of concentration with Raman intensity. The fact that concentration and Raman intensity are directly proportional greatly aids in this correlation.

The Raman spectrum of H_2 is composed of two regions: a pure rotational region between 0-600 cm^{-1} , and a vibrational-rotational region in the 4000-4200 cm^{-1} region. For intensity measurements the Q-branch at 4155 cm^{-1} is used, this being the strongest band in the spectrum. Thus, the purpose of this report is to describe a simple technique for calibrating different concentrations of H_2 gas for instrument reliability tests. The results will serve as another check on calibration values or as an alternative to other calibration methods. This will aid in areas in which Air Force operations require determined levels of gases, in particular hydrogen, to be monitored.

EXPERIMENTAL PROCEDURE

Research grade hydrogen (H_2) was used in the preparation of the gas mixtures. Three mixtures were used: 100%, 1% (in N_2), and 0.1% (in N_2). Hydrogen mixtures were prepared by standard PVT techniques; sampling tanks were filled to approximately four atmospheres. These tanks were connected to a high-vacuum glass line. The vacuum line contained a Wallace/Tiernier pressure gauge and the multipass Raman gas cell. The entire system was evacuated under a hard vacuum ($>10^{-4}$ mm Hg). Approximately 0.66 atmospheres of H_2 were deposited in the gas cell. The cell was removed and placed in the sample compartment in the spectrometer.

A Cary Model 82 Raman spectrophotometric system was used for measuring the spectra. For an excitation source a Spectra Physics Model 170-03 argon-ion laser was used; the 5145 Å line was used. Laser power output was monitored with a Cary laser power meter measured at the sample.

In Figure 1 is shown the multipass apparatus used for these measurements. The laser beam is deflected 90° by a right-angle prism and directed vertically upwards through a 209-mm focal-length lens. The beam on its first traversal barely clips the bottom mirror and hits the top mirror close to the center. The beam is made to reflect many times from each mirror (multipassing) by a procedure involving the adjustment of the space between the two mirrors and by properly tilting the mirrors. This procedure is repeated with the gas cell in place for proper multipassing adjustment. This is necessary since the separation of the mirrors is a function of the index of refraction of the sample. The multipassing technique is designed to increase the signal input to the spectrometer. The usual gain achieved for a typical gas is between a 10-14 factor improvement. The sampling state consists of four micro-positioned translation platforms; the bottom two adjust the multipass apparatus while the top two adjust the cell position. Light scattered at 90° is collected by a fast lens and transferred to the spectrometer. In Figure 2 is shown the gas cell mounted in its holder. The optical flats are set at the Brewster angle. The beam traverses the long axis of the cell while the scattered radiation is collected out the side of the cell. The backing mirror provides only very little improvement in signal response for gases.

RESULTS AND DISCUSSION

In Figure 3 is shown the complete Raman spectrum for H_2 for the spectral region, $0-4400\text{ cm}^{-1}$. The spectral assignment for the various bands has been well documented and discussed (1). The four low frequency bands appearing at 355 , 586 , 816 , and 1035 cm^{-1} are pure rotational bands corresponding to changes in the rotational energy levels in the H_2 molecule. The selection rules for pure rotational energy level changes in the Raman effect are $\Delta J=0, +2$. The observed bands can be assigned as follows: $355(J,0-2)$; $586(J,1-3)$; $816(J,2-4)$; $1035(J,3-5)$. All of these transitions correspond to $v=0$ (the lowest or ground vibrational energy level). The strongest rotational line is the $586(J,1-3)\text{ cm}^{-1}$ band. The higher frequency bands, occurring at 4126 , 4143 , 4155 , and 4161 cm^{-1} , are vibration-rotation bands. These correspond to rotational energy level changes between the vibrational energy states, $v=0$ and $v=1$. These bands can be assigned as follows: $4161(J,0-0)$; $4155(J,1-1)$; $4143(J,2-2)$; $4126(J,3-3)$. All of these transitions correspond to $v=0 \rightarrow v=1$; also, these are labelled as Q transitions since they involve $\Delta V=1$ and $\Delta J=0$. The strongest band here is $4155(J,1-1)\text{ cm}^{-1}$. These bands can be seen more easily in Figure 4 where the frequency scale has been increased to allow more separation between the observed bands. For the 4155 cm^{-1} band the full bandwidth at half-max (FBWHM) is approximately 1 cm^{-1} . Compared to other gases hydrogen exhibits an extremely narrow band spectrum; this is due mainly to its light molecular weight and simple geometry (homonuclear diatomic, point group symmetry = $D_{\infty h}$). The 4155 cm^{-1} band being the strongest in the entire spectrum was chosen as the calibration line for hydrogen. No other gas exhibits a gas phase frequency close to this band; thus, its position is ideal for mixtures involving a multitude of gases.

1. Teal, G. K., and G. E. MacWood. The Raman spectra of the isotopic molecules H_2 , HD, and D_2 . J Chem Phys 3:760 (1935).

In Figures 5-11 are shown the results for the concentration measurements for 100%, 1%, and 0.1% H₂. In a series of concentration measurements all instrumental parameters must be maintained constant for each recording to obtain accurate and reproducible results. For the duration of an experiment the laser power level at the sample was monitored and found to remain constant to within + 5 mW. This small variation has a negligible effect on intensity changes actually observed. Gas-fill procedures did not introduce any appreciable error since the pressure readings were very reproducible. The multipass gas cell was held in position by a cell holder. Actually small changes in the cell's position had very little effect on the intensities. In a series of experiments for one concentration the spectral bandwidth, period, scan speed, and laser power were constant; spectral bandwidth was increased for the 1% and 0.1% hydrogen mixtures.

Figure 5 shows the results obtained for the 100% H₂ sample for various spectral bandwidths (SBW) at constant gain and laser power. The bandwidths were increased from 1 cm⁻¹ to 10 cm⁻¹. These values are actually related to resolution of component bands. To a first approximation a 1 cm⁻¹ bandwidth would allow resolution of two bands 1 cm⁻¹ or more apart. The effect of bandwidth on the structure of the H₂ vibration-rotation modes is easily and dramatically displayed in this figure. At 1 cm⁻¹ SBW all four bands are easily identified; however, as the SBW values are increased the 4161 cm⁻¹ band slowly disappears as does the 4143 cm⁻¹ band. For the 4155 cm⁻¹ band the FWHM increases from 2 cm⁻¹ at SBW = 1 cm⁻¹ to 13 cm⁻¹ at SBW = 10 cm⁻¹. The relationship between spectral bandwidth and Raman intensity is shown in Figure 6. This is a plot of Raman intensity for the 4155 cm⁻¹ band vs. spectral bandwidth. As can be seen, this is a linear relationship for the spectral bandwidth between 1 and 10 cm⁻¹. The standard relation between spectral bandwidth and intensity is that by doubling the bandwidth, the intensity increases by a factor of four. From the graph here for H₂, this is clearly not the case; the intensity for H₂ increases at a much slower rate.

Figure 7 shows the recordings for 100% H₂ at a SBW = 1 cm⁻¹ and a gain of 200,000, 20,000, and 2,000 counts/sec. The peak height intensity for the 4155 cm⁻¹ band is shown. The gain factor and Raman intensity show the predicted trend: a tenfold increase in gain results in a tenfold increase in Raman intensity. The gain setting at 200,000 counts/sec produced an intensity of 6.0 while the gain setting at 20,000 counts/sec gave an intensity of 60.7. For the gain setting of 2,000 counts/sec the Raman intensity for this band was off-scale. However, for the 4126 cm⁻¹ band, intensities were measured for each of the three gain settings. For the settings of 200,000, 20,000, and 2,000 counts/sec, intensities measured were 0.9, 9.0, and 89.0, respectively. Again, there is good agreement, even for the lowest and highest gain settings (this being a factor of 100). These three gain settings were recorded in order to verify the standard rule regulating gain and intensity so that different concentrations could be recorded under similar gain settings and the intensity would relate directly to concentration. For example, if a 1% H₂ mixture were recorded under the same gain settings, then the results for the

4125 cm^{-1} band should be as follows: for gain settings of 200,000, 20,000, and 2,000 counts/sec, intensities are 0.009, 0.09, and 0.9, respectively. Clearly only the high gain setting would give a measurable intensity. This low intensity would indicate the need to increase the spectral bandwidth as indicated in Figure 6 and also the need to monitor the more intense 4155 cm^{-1} band. The 1% H_2 mixture is shown in Figure 8 for the spectral bandwidth of 1 cm^{-1} and gain settings of 200,000, 20,000, and 2,000 counts/sec. The only really measurable Raman intensity comes from the 2,000 counts/sec measurement. Here we observe an intensity of 6.0. In Figure 7 we observed an intensity of 60.7 for the 100% H_2 at a gain setting of 20,000 counts/sec. The corresponding 2,000 counts/sec intensity reading would have been approximately 607. Clearly a 1% H_2 mixture would then give a reading of 6.07. This is very close to that actually observed. Thus, assuming the 100% H_2 concentration to be accurate the 1% H_2 concentration tested was shown to be accurate also, this being based on the observed intensities. As an additional check on the 1% H_2 sample, this sample was recorded at a spectral bandwidth of 8 cm^{-1} (Fig. 9). For gain settings of 20,000 and 2,000 counts/sec, measurable intensities were obtained; at 20,000 counts/sec, $I=8.5$ and at 2,000 counts/sec, $I=82.0$. There is good agreement between the two gain settings and the intensities. Also, there is excellent agreement in intensity increase for the spectral bandwidth increase from 1 to 8 cm^{-1} . This can be seen by comparing the appropriate bandwidths in Figure 6.

The last H_2 sample recorded was the 0.1% mixture. The results are shown in Figures 10 and 11. In Figure 10 the spectral bandwidth was 1 cm^{-1} and the gain settings as usual. No measurable intensities were obtained with these settings; therefore, the bandwidth was increased to 8 cm^{-1} (Fig. 11). Intensities are observed for gains of 20,000 and 2,000 counts/sec. These were 1.2 and 12.4, respectively. Between the two gain settings there is good agreement. However, by a comparison between the 1% intensity values and these intensity values there appears to be some discrepancy. The 1% H_2 values were checked against the 100% H_2 values and found to be quite accurate; it is thus assumed that the 1% H_2 values are also accurate. With this assumption, the 0.1% H_2 values appear to be high, indicating a concentration greater than 0.1%. If the 0.1% H_2 concentration were accurate then the Raman intensity for the gain of 2,000 counts/sec should have been approximately 8.2; this is compared to that actually observed, 12. Clearly Raman has detected an error in a standard which would have been used to calibrate a H_2 detection instrument. The approximate concentration to which this corresponds is 0.15%. The error, based on the reproducibility of the recordings and the gain vs. intensity relationships, is $\pm 0.05\%$.

It has been shown by measuring the Raman spectra of three concentrations of hydrogen that accurate estimates of these concentrations can be obtained quickly, easily, and without recourse to highly sophisticated instrumental techniques. Raman offers the advantages of no spectral interference for H_2 and ease of gas sample preparation. For sample concentrations of 0.1% or higher, Raman offers a routine recording capability. Below this concentration, higher laser powers, larger spectral

bandwidths, and higher gains would have to be employed. Theoretically, by using a gain of 200 counts/sec, 20 cm^{-1} SBW, and laser power of 4 watts at the sample, the lower detection limit would be 0.001%; this would give an intensity of at least 12.

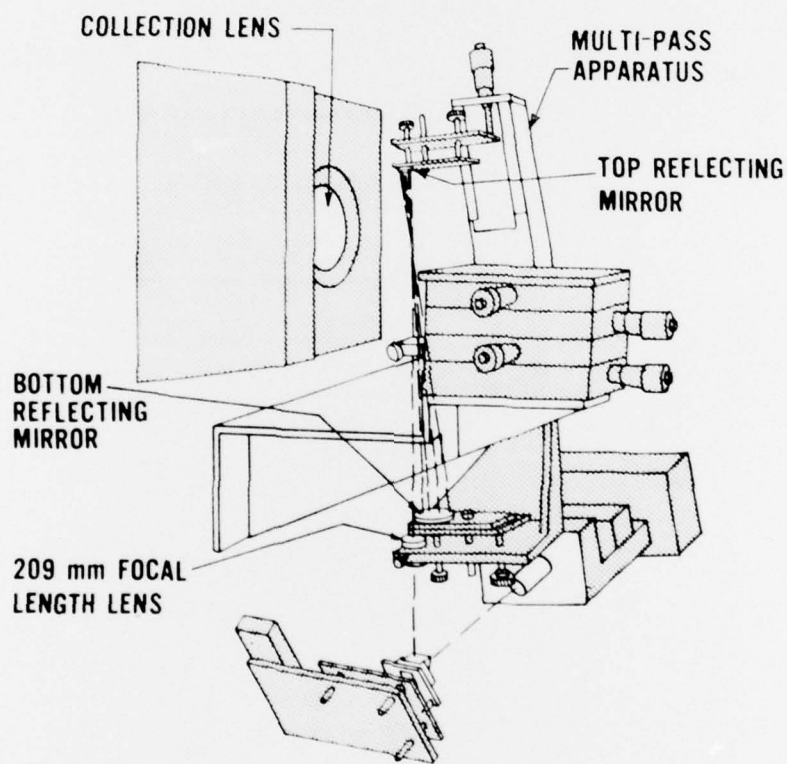

Figure 1. Raman multipass setup for gas samples.

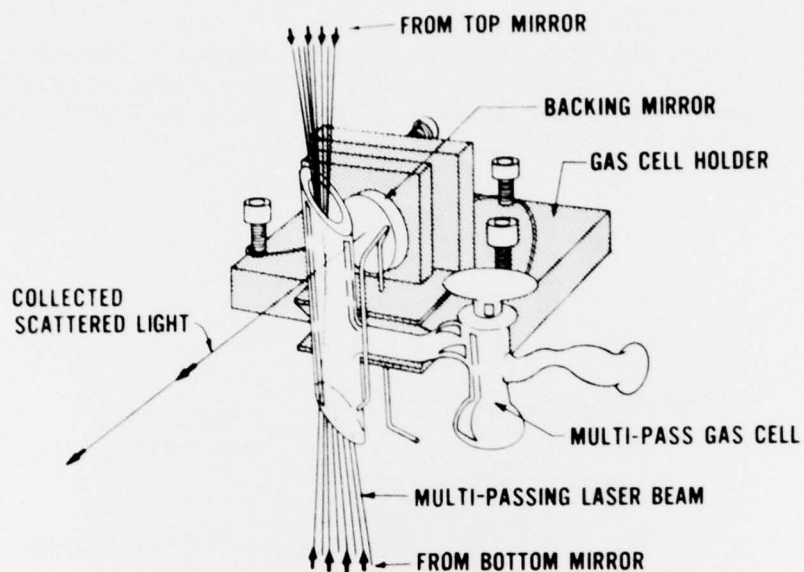

Figure 2. Multipass Raman gas cell.

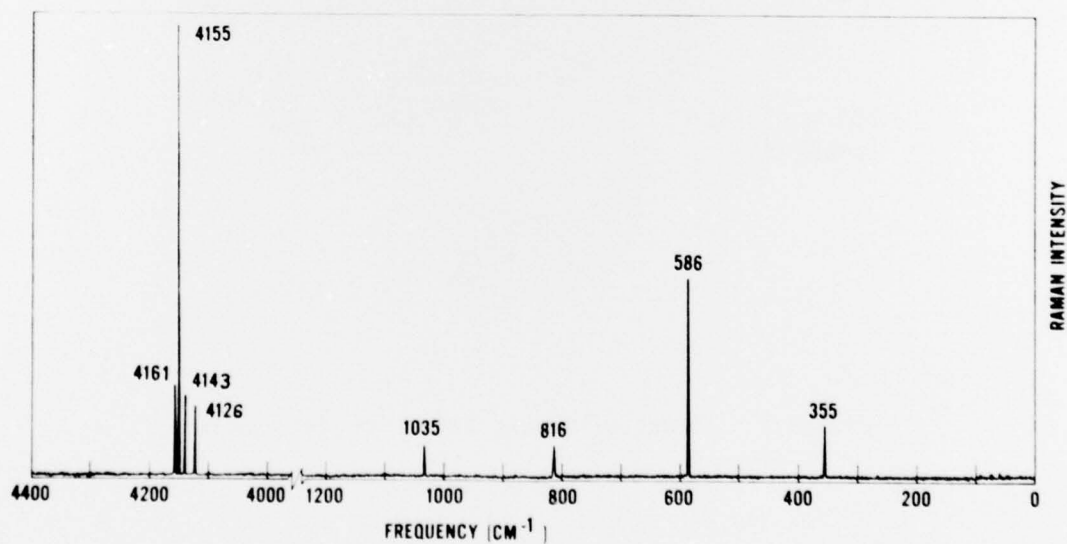

Figure 3. Raman spectrum of 100% H₂ (0.66 atm. H₂ sample; laser power = 0.5 watts at sample; SBW = 1 cm⁻¹; gain = 5000 counts/sec; period = 2 sec; scan speed = 0.2 cm⁻¹/sec).

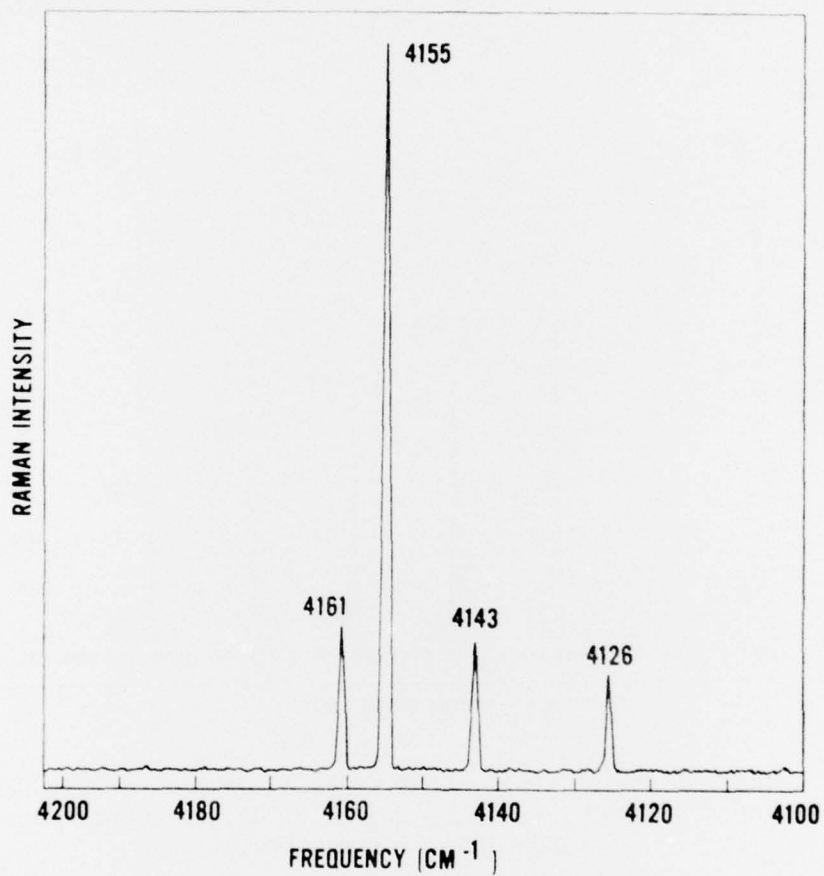

Figure 4. Raman spectrum of vibration-rotation region at high gain (laser power = 1.0 watt at sample; SBW = 0.5 cm⁻¹; gain = 1,500 counts/sec; period = 2 sec; scan speed = 0.2 cm⁻¹/sec).

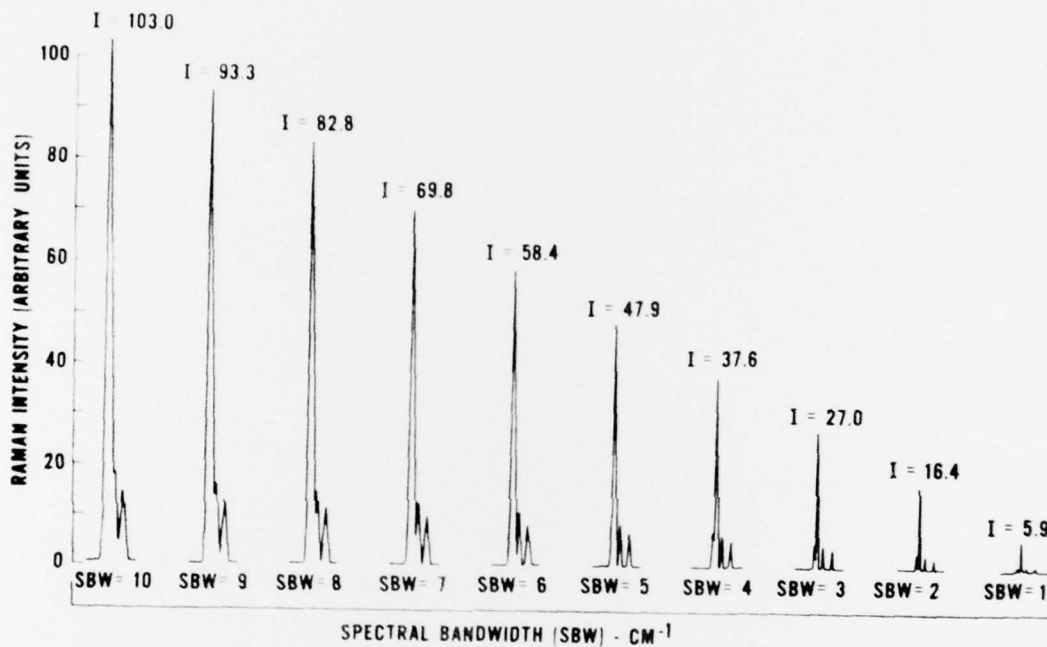

Figure 5. Raman spectra showing intensity as a function of SBW (laser power = 1.5 watts at sample; gain = 200,000 counts/sec; period = 1 sec; scan speed = 1 $\text{cm}^{-1}/\text{sec}$).

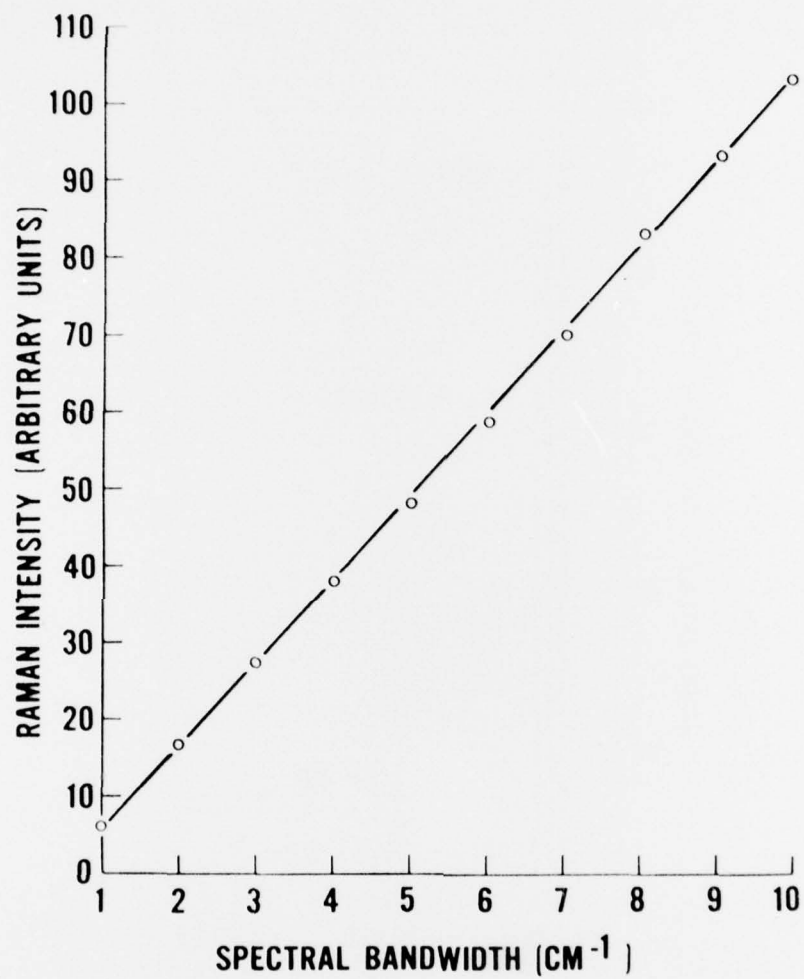

Figure 6. Plot of Raman peak height intensity for the 4155 cm^{-1} band vs. spectral bandwidths (results from Figure 5 spectral measurement).

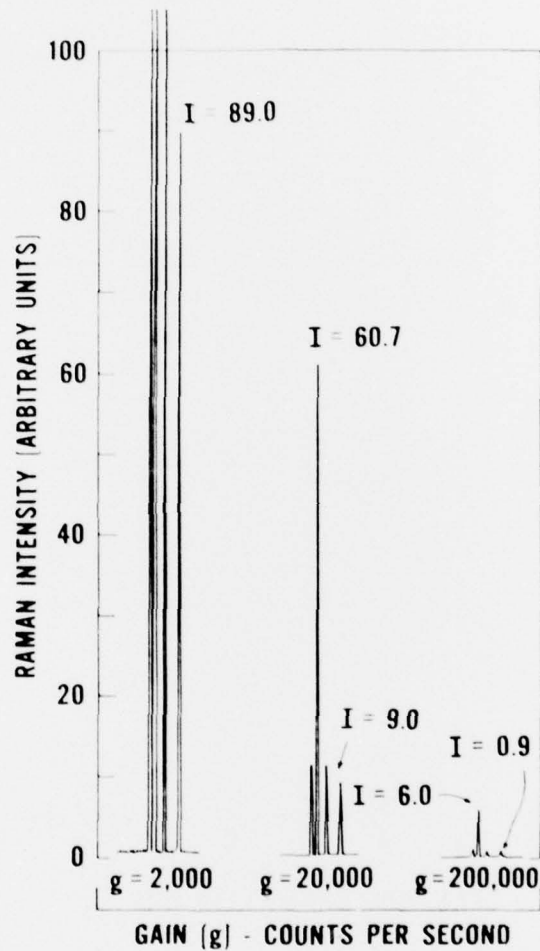

Figure 7. Raman spectra of 100% H₂ for the region 4100-4200 cm⁻¹ (laser power = 1.5 watts at sample; SBW = 1 cm⁻¹; period = 2 sec; scan speed = 0.5 cm⁻¹/sec).

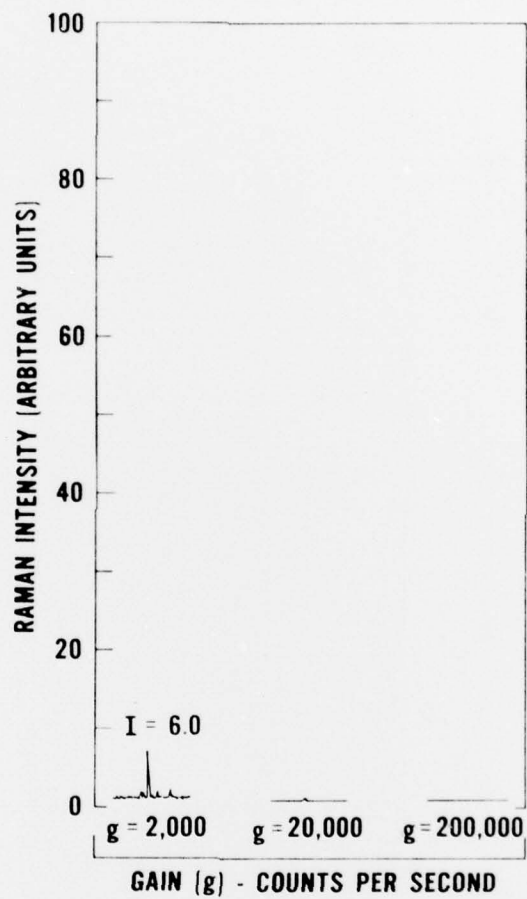

Figure 8. Raman spectra of 1% H₂ for the region 4100-4200 cm⁻¹ (experimental conditions the same as in Figure 7).

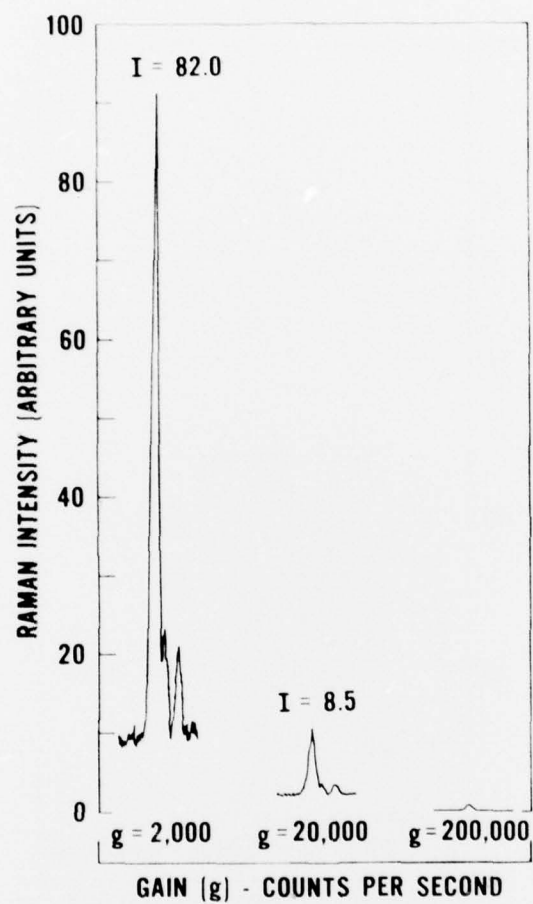

Figure 9. Raman spectra of 1% H₂ for the region 4100-4200 cm⁻¹ (experimental conditions the same as in Figure 7, except SBW = 8 cm⁻¹).

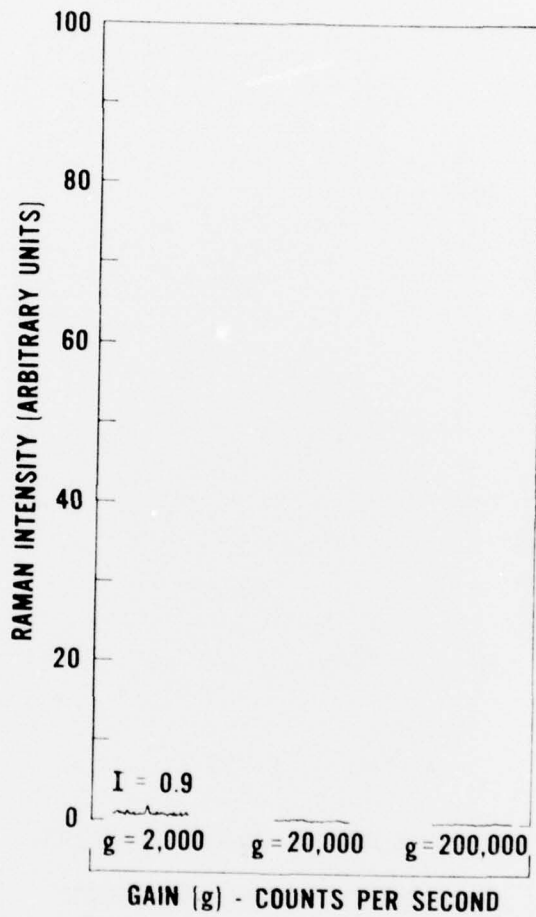

Figure 10. Raman spectra of 0.1% H₂ for the region 4100-4200 cm⁻¹ (experimental conditions the same as in Figure 7).

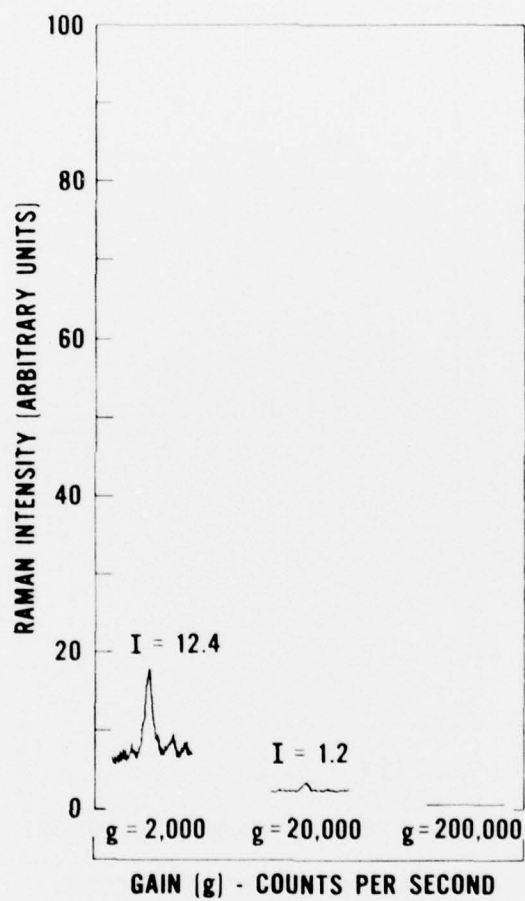

Figure 11. Raman spectra of 0.1% H₂ for the region 4100-4200 cm⁻¹ (experimental conditions the same as in Figure 7, except SBW = 8 cm⁻¹).