

AD-A052 682

WISCONSIN UNIV-MADISON
MEASURING ELECTRIC FIELD DISTRIBUTION IN A MICROWAVE OVEN.(U)
1974 E C RINGLE

F/G 6/8

UNCLASSIFIED

NL

| OF |
AD
A052 682



END
DATE
FILMED
5-78
DDC

AD A 052682

AD NO. ODC FILE COPY

P

6 MEASURING ELECTRIC FIELD DISTRIBUTION
IN A MICROWAVE OVEN

BY

7 Master's thesis,

10 ELMER CHARLES/RINGLE

A thesis submitted in partial fulfillment of the requirements for the degree of

MASTER OF SCIENCE
(Food Science)

at the

UNIVERSITY OF WISCONSIN - MADISON

DDC
APR 4 1978
F

11 1974

12 77p.

This document has been approved for public release and sale; its distribution is unlimited.

380 100

mt

ACKNOWLEDGMENTS

The author wishes to express his sincere appreciation and gratitude to:

Beatrice Donaldson David, Ph. D., Professor of Food Science, for her inspiration, guidance and encouragement throughout the study;

Daryl B. Lund, Ph. D., Associate Professor of Food Science, for his technical assistance in formulating this study;

Jerome Senturia, Ph. D., Assistant Professor of Agronomy and Statistics, for his guidance and assistance with the statistical analyses;

Mr. Ardin Hardie, Specialist in Dairy Science, for assistance with use of the computer for statistical analyses;

The Graduate School of the University of Wisconsin, College of Agricultural and Life Sciences and the United States Army for financial assistance.

ACCESSION for	
NTIS	White Section <input checked="" type="checkbox"/>
DDC	Buff Section <input type="checkbox"/>
UNANNOUNCED JUSTIFICATION	<input type="checkbox"/>
<i>on file</i>	
BY	DISTRIBUTION AVAILABILITY CODES
	1 2 3 4 5 6 7 8 9 10 11 12
<i>A</i>	

TABLE OF CONTENTS

	Page
ACKNOWLEDGMENTS	ii
LIST OF TABLES	v
LIST OF FIGURES	vii
DEFINITION OF TERMS	viii
CHAPTER	
1. INTRODUCTION	1
1.1 Identification of the Problem.	2
1.2 Purpose of the Research.	3
2. REVIEW OF LITERATURE	4
2.1 Effects on Food of Uneven Electric Field Distribution in a Microwave Oven	4
2.2 Current Methodology For Measuring Electric Field Distribution in Microwave Ovens.	5
3. MATERIALS AND METHODS.	10
3.1 Experiment I. Determining the Output Wattage of the Microwave Oven.	10
3.2 Experiment II. Selecting a Low Di- electric Loss Substance to be Used as a Vehicle for Measuring Electric Field Distribution	12
3.3 Experiment III. Using the Non-Enzymatic Browning Reaction in a Model System to Measure Electric Field Distribution.	17
3.31 The Non-Enzymatic Browning Reaction in a Model System	20
3.32 Procedure For Making Glucose/ Glycine Solution	21

CHAPTER	Page
3.4 Experiment IV. Procedure For Measuring Electric Field Distribution in a Microwave Oven.	24
3.41 Glucose/Glycine Impregnation Procedure.	25
3.42 Microwave Heating of the Test Media.	27
3.43 Sample Design and Analysis	28
3.44 Matrix Extraction and Sample Dilution Procedure	30
3.45 Spectrophotometer Analysis.	33
4. RESULTS AND DISCUSSION	37
4.1 Analysis of Data	38
4.2 Results of the Analysis.	39
4.3 Discussion	43
5. SUMMARY, CONCLUSIONS AND RECOMMENDATIONS	51
5.1 Summary.	51
5.2 Conclusions	52
5.3 Recommendations.	55
APPENDIX.	58
REFERENCES.	66

LIST OF TABLES

TABLE	Page
3.11 OUTPUT WATTAGE FOR THREE DIFFERENT POSITIONS IN A MICROWAVE OVEN RATED AT 1300 WATTS.	14
3.21 TEMPERATURE INCREASE OF 50 ML OF WATER HEATED FOR 10 SECONDS IN A MICROWAVE OVEN WITH AND WITHOUT FIBER GLASS PRESENT	19
4.11 Q-TEST VALUES FOR ORIGINAL AND TRANSFORMED ABSORBENCY UNITS FOR THE BROWNING REACTION COLLECTED FROM 45 SAMPLE CELLS OF FIBER GLASS EXPOSED IN A MICROWAVE OVEN	40
4.21 ANALYSIS OF VARIANCE OF ABSORBENCY UNITS FOR THE BROWNING REACTION COLLECTED FROM 45 SAMPLE CELLS OF FIBER GLASS USED TO MEASURE ELECTRIC FIELD DISTRIBUTION IN A MICROWAVE OVEN: TRANSFORMED $\sqrt{X + .5}$	41
4.22 ANALYSIS OF VARIANCE OF ABSORBENCY UNITS FOR THE BROWNING REACTION COLLECTED FROM 45 SAMPLE CELLS OF FIBER GLASS USED TO MEASURE ELECTRIC FIELD DISTRIBUTION IN A MICROWAVE OVEN: ORIGINAL DATA	42
4.23 SIGNIFICANT DIFFERENCES BETWEEN ABSORBENCY UNIT MEANS IN EACH OF THE FIVE LEVELS FOR EACH OF THE AREAS STUDIED IN A MICROWAVE OVEN.	44

APPENDIX TABLE

1 DILUTION FACTOR AND ABSORBENCY UNITS FOR THE BROWNING REACTION COLLECTED FROM 45 SAMPLE CELLS OF FIBER GLASS USED TO MEASURE ELECTRIC FIELD DISTRIBUTION IN A MICROWAVE OVEN.	59
2 RANGE, MEAN AND VARIANCE OF ABSORBENCY UNITS FOR THE BROWNING REACTION COLLECTED FROM 45 SAMPLE CELLS OF FIBER GLASS USED TO MEASURE ELECTRIC FIELD DISTRIBUTION IN A MICROWAVE OVEN.	62
3 ESTIMATE OF TREATMENT MEANS OF ABSORBENCY UNITS FOR THE BROWNING REACTION FROM NINE AREAS OF FIBER GLASS USED TO MEASURE ELECTRIC FIELD DIS- TRIBUTION IN A MICROWAVE OVEN.	64

LIST OF TABLES (CONTINUED)

APPENDIX TABLE

Page

4	ESTIMATE OF TREATMENT MEANS OF ABSORBENCY UNITS FOR THE BROWNING REACTION FOR FIVE LEVELS OF FIBER GLASS USED TO MEASURE ELECTRIC FIELD DISTRIBUTION IN A MICROWAVE OVEN.	65
---	---	----

LIST OF FIGURES

FIGURE	Page
3.11 DESCRIPTION AND OPERATING SPECIFICATIONS OF THE COMMERCIAL MICROWAVE OVEN USED IN ELECTRIC FIELD DISTRIBUTION MEASUREMENT STUDY . . .	11
3.12 THE THREE SHADED POSITIONS REPRESENT THE AREAS OF A MICROWAVE OVEN CHECKED FOR OUTPUT WATTAGE. . .	13
3.21 RELATIVE LOCATION OF THE WATER CONTAINER AND FIBER GLASS IN A MICROWAVE OVEN DURING DIELECTRIC LOSS EXPERIMENTS.	18
3.311 NON-ENZYMATIC BROWNING REACTION RATE IN RELATIONSHIP TO TEMPERATURE.	22
3.431 LEVEL AND AREA IDENTIFICATION OF 45 INDIVIDUAL CELLS USED FOR MEASURING ELECTRIC FIELD DISTRIBUTION IN A MICROWAVE OVEN.	31
3.451 WAVELENGTH SCAN OF MICROWAVE HEATED GLUCOSE/ GLYCINE EXTRACTION: LIGHT YELLOW.	34
3.452 WAVELENGTH SCAN OF MICROWAVE HEATED GLUCOSE/ GLYCINE EXTRACTION: DARK AMBER	35
4.31 INTERACTION OF LEVELS AND AREAS FOR ELECTRIC FIELD CONCENTRATION IN A MICROWAVE OVEN	46
4.32 A TOP VIEW OF THE NON-ENZYMATIC BROWNING REACTION IN THE FIBER GLASS AFTER EXPOSURE IN A MICROWAVE OVEN; AREA GRID LINES SUPER-IMPOSED TO SHOW INDIVIDUAL SAMPLE CELLS	47
4.33 APPROXIMATE LOCATION IN A MICROWAVE OVEN OF AN EIGHT INCH PLATE NORMALLY USED TO HEAT PORTIONED FOODS, SUPER-IMPOSED ON THE AREA GRID MEANS OF ABSORBENCY UNITS OF THE BROWNING REACTION; HARD TO HEAT FOOD ITEM (A) AND EASY TO HEAT FOOD ITEM (E) POSITIONED IN AREAS OF HIGH AND LOW ELECTRIC FIELD INTENSITY, RESPECTIVELY.	49

DEFINITIONS

Cavity

Denotes the space enclosed by inner walls and door into which food is placed to be heated or cooked by microwave energy.

Microwave oven

Denotes microwave cooking appliance designed to heat food by microwave energy.

Output wattage (Measured)

Cooking power available in the oven cavity as measured by a water temperature rise test and converted to watts.

Output wattage (Rated)

Cooking power available in the oven cavity as stated in specifications by the manufacturer.

Shelf

A horizontal food supporting surface in the cavity of a microwave cooking appliance.

Standing wave pattern

Collection of incident and reflected microwave energy in a microwave oven that is based on the stirrer and cavity design and specific for a microwave oven of a particular model and manufacturer.

Stirrer

Denotes a moving propeller-like element used in microwave cooking appliances to diffuse the microwave energy throughout the cooking cavity.

Usable cavity volume

Calculated as the geometric shape bounded by a shelf in the lowest position, by the sides of the cavity, by the ceiling and the closed door. Any projection is considered as reducing the cavity volume as though a plane existed through the extremity of the projection.

DEFINITIONS (CONTINUED)

Spun fiber glass

Finespun filaments of glass assembled in a matrix type structure and generally used as an air filtering media.

CHAPTER 1

INTRODUCTION

Microwave oven users encompass a broad category and include hospital foodservices, restaurant and commercial fast-food services, school foodservice programs, domestic consumers, busy professionals, the elderly, the handicapped and youth. Also included are teachers and students of foods and equipment in high schools and in university home economics, hotel and motel and restaurant programs. Microwave oven sales are expected to attain 640,000 units in 1974. This almost doubles the 325,000 units sold in 1972. Sales are projected to exceed one million units by 1978.

The microwave heating of portioned and individual food items has been well established in the foodservice industry. Hospital foodservices, restaurants, vending operations and industrial mass feeding operations are increasing their use of microwave ovens to augment conventional food reconstitution methods. In spite of the large number of microwave ovens currently in operation, user application has not been optimal. The electric field distribution limits the optimization procedure, particularly with regard to moisture and temperature distribution in the heated food (Stuckly, 1972).

1.1 Identification of the Problem

The microwave oven heats by radiation. The radiation consists of electromagnetic energy in the radio-frequency spectrum. In a microwave oven the electromagnetic waves are produced by a magnetron. The waves are coupled by a wave guide to the oven cavity in which the food is exposed to the electromagnetic waves. When food or other polar substances are placed in a microwave field they quickly become hot because of the absorbed energy from the microwaves. This energy is transferred into heat within the polar substance itself by a molecular friction effect. Substances of different cellular and molecular structure absorb microwaves differently; hence heating rates are influenced by food composition.

As microwave energy enters the oven cavity, distribution of the incident waves is accomplished by a wave stirrer. Reflected waves from the inner metal surface of the oven cavity also contributes to the distribution pattern of microwave energy. Because microwave energy travels in a straight line, reflected and incident waves contribute to a specific distribution. The specific distribution is referred to as the standing wave pattern. In the zone where the energy is reflected from the walls and floor of the oven cavity, the metal has a reducing effect close to its surface. This zone is about 1-2 cm (Napleton, 1971). Therefore, areas of high and areas of low electric fields are produced. The effect of uneven heat distribution

on the quality of portioned food is one of the major problems of microwave heating. The dimensions of portioned food seldom exceed the penetration depth of microwave energy and in most cases transmission of the energy will occur. If the majority of energy is transmitted, the standing waves of the microwave oven are essentially unaltered and hot and cold spots become an important parameter to be considered when heating portioned food in a microwave oven.

1.2 Purpose of the Research

Uneven heating of portioned foods in a microwave oven is a problem. Current methods of identifying uneven distribution do not record the standing electric field pattern in areas and levels of the microwave oven simultaneously. If more even heating is to be achieved, special attention must first be given to the electric field distribution in the oven's cavity.

The purpose of this research was to develop a method for measuring electric field distribution in a microwave oven.

CHAPTER 2

REVIEW OF LITERATURE

A review of literature revealed that recognition has been given to the problem of uneven heating in a microwave oven. Methods developed for measuring electric field distribution in a microwave oven were varied and there appeared to be little agreement on any specific procedure which could be standardized.

2.1 Effects on Food of Uneven Electric Field Distribution in a Microwave Oven

Concern for uneven cooking and quality of food heated in microwave ovens was expressed in the literature. The uneven electric field concentrations (and resulting heat energy) have a deleterious effect on food components (Van Zante, 1973). Only one study was found that correlated electric field distribution with its effect on food. Tracy (1974) developed a method for determining electric field distribution in a microwave oven and evaluated its effect on portioned food. Using a formulation of skim milk powder, cornstarch, corn syrup and water, electric field concentrations were determined by the resulting non-enzymatic browning reaction. Eight levels each $\frac{1}{2}$ inch above the preceding one were divided into 144 sections each 1 x 1 inch. The resulting thermogram was objectively measured using a light reflection meter. A second objective

measure of the electric field concentration was accomplished by heating 8 ml of water in each of the 144 cells. Once the heating pattern was established, the effect of hot and cold cells was determined based on portioned chilled foods heated in various areas of the oven. Weight loss, temperature and sensory evaluation scores showed a significant inter-relationship between the percentage reflection and temperature change measurements and the change in temperature and amount of moisture lost from the food products during microwave heating. Ground beef patties heated in the hotter areas were rated significantly more dry and more firm. The results of this study indicated that uneven electric field concentrations have important implications for quality of prepared and portioned food heated in a microwave oven where there is uneven energy distribution.

Bengtsson (1969) determined heating patterns of foods heated in a microwave oven using an infra-red television camera. Isothermic patterns of the food surface could be monitored during the heating cycle. Observations noted were that the electric field was uneven and that the initial pattern recorded remained unchanged throughout the heating period. The effect on food quality was not reported.

2.2 Current Methodology For Measuring Electric Field Distribution In Microwave Ovens

Because thermocouples and conventional thermometers cannot be used in the microwave oven chamber during heating, it has become necessary to turn to biological materials to

measure uneven heat distribution in the oven. If an alcohol or mercury thermometer is placed in a microwave oven, errors will occur due to the heating of alcohol or mercury by the microwave energy. If a thermocouple or a thermistor enclosed in a thin metal tube is used, a concentration of an electric field will occur around the electric wire or metal tube. One microwave oven manufacturer advertizes a metal shielded thermometer available for use in a microwave oven but its use is not applicable for portioned food.

Watanabe (1974) developed a dielectric sheath which precludes the energy concentration effect around thermometers and thermocouples. By placing the thermometer in a metal tube and wrapping the metal tube in a low-loss dielectric, the electric flux density between the material being measured and the thermometer is greatly reduced. Although accurate, the new sheath thermometer has a slow response time.

Van Zante (1966) used egg whites placed in individual cups to chart electric field concentrations. Twenty-three grams of egg white were placed in nine Pyrex custard cups. The egg white, in the cups, was then placed at equidistant points in the microwave oven. Heating was terminated when the first egg white appeared completely coagulated. Areas where the egg white was uncoagulated were referred to as "cold spots". The major shortcoming of this procedure was the lack of information in areas where the cups were not located.

Another technique using egg white for measuring electric

field concentrations was reported by Wilhelm and Satterlee (1971). Egg white was blended in a Waring blender and poured onto a flat Pyrex plate. When heated in a microwave oven, changes in the egg white as it coagulated during the heating process were used as an indication of hot spots. By elevating the glass plate, various planes of the microwave oven were measured for electric field concentrations.

Reports indicated that researchers were using a variety of foods to determine electric field distribution. Most manufacturers of household microwave ovens feel that the only representative method of determining electric field distribution is to cook a variety of foods representing large, medium and small loads (Weizeoričk, 1974). Peterson and Foerstner (1971) selected cup cakes, potatoes, layer cakes, roasting chickens and meat loaves to evaluate oven performance. Cooking results were judged by temperature measurements taken at a specific position in each food after cooking. Subjective quality assessments were also made to determine electric field concentrations. Sixteen different microwave ovens were tested. The authors stated that, better than any other method, cup cakes showed the true energy distribution pattern in a microwave oven. There was no description of how the "true" energy pattern was determined. The complexity of using food items for developing a standardized and reliable electric field measurement technique was pointed out by the variability of scores among food items heated in a variety of microwave ovens.

Scott (1973) developed a simulated food to measure microwave oven cooking performance. A formulation of gelatin, water, sugar and food coloring were combined to an equivalent moisture content of most meats. The gelatin mold mixture was placed in a microwave oven and energy applied for a specific period of time. Periphery and internal melt characteristics of the gelatin were then graded using a grid. Uneven melt characteristics were then assigned a score which was deducted from the base score of 10 points. The procedure was proposed to the International Microwave Power Institute in September 1973 as an international performance standard.

A non-biological approach to measure electric field concentrations was reported by Kumpfer (1972). The method, which was developed at American Microwave, Inc., provided a two-dimensional "picture" of the energy distribution pattern. A sheet of asbestos was wetted with water and placed in the plane to be studied. When microwave energy was applied the color of the asbestos paper changed from a dark gray to a pure white. The gradation of color was interpreted as being representative of energy distribution in the plane being studied. The procedure was not quantitative and measured electric field patterns in only a single plane.

Other non-biological techniques using wet blotters and thermofax film were described and were useful in pointing out the possibility of uneven cooking; however

the techniques do not lend themselves to positioning specific food loads (Van Zante, 1973).

Increase in temperature of water has been used for a number of years by most manufacturers of microwave ovens to evaluate performance (Scott, 1973). Such a test was the basis for a draft proposal submitted to Sub-Committee 59H (microwave appliances), International Electrotechnical Commission, for consideration as a test standard for determining electric field distribution in a microwave oven (Weizeorick, 1974). The proposal suggested an array of several and/or individual beakers of water heated in various locations to determine repeatability, height sensitivity, average UHF efficiency and distribution grade of microwave ovens. In October 1974, Sub-Committee 59H issued a statement which said that a test method for determining the microwave field distribution in the cavity could not be recommended. Each National Committee was requested to study this specific problem to determine if an acceptable method for measuring electric field distribution could be developed.

CHAPTER 3

MATERIALS AND METHODS

For this study the intent was to chart the electric field of the cooking area in a microwave oven through a single exposure technique, thereby providing a three-dimensional picture of energy distribution within the oven cavity. Basic requirements to accomplish this objective were: (a) a low dielectric loss material with an "open" type matrix that would transmit microwave energy, and (b) a heat activated chemical reaction with an exponential relationship to temperature that could be measured objectively.

3.1 Experiment I. Determining the Output Wattage of the Microwave Oven

A description of the oven used in this research and its operating specifications are given in Figure 3.11.

Of primary importance in microwave oven research is knowledge of the frequency of the microwave energy and the amount of cooking power delivered to the food (Tracy, 1974). The wattage output (cooking power) of most ovens is 10 to 15 per cent below the rated output stated by the manufacturer. Van Zante (1973) suggested that Method Number Six was the most usable and reliable method of measuring microwave oven cooking power. The procedure involves a conversion to wattage of British thermal units (Btu) that

MICROWAVE OVEN

11

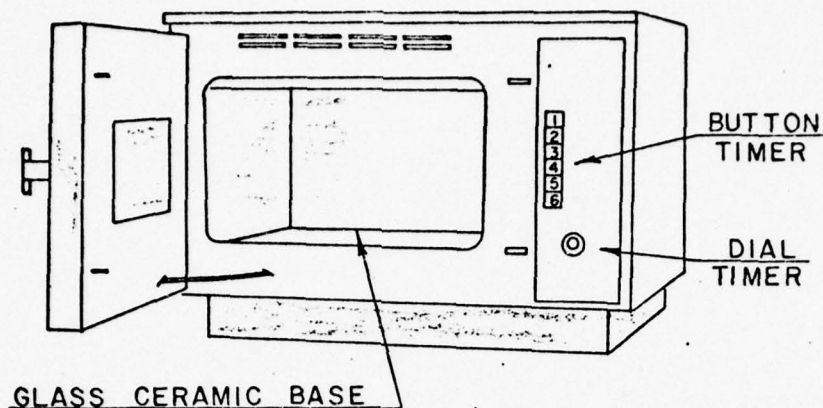

DIMENSIONS:

Cabinet: Width 21 5/8 inches, height 15 inches
depth 21 1/2 inches

Cavity: Width 13 inches, height 7 5/16 inches,
depth 13 inches

Glass Ceramic Base Shelf: Width 12 inches, depth 12 inches

ELECTRICAL SPECIFICATIONS:

Voltage: 208 to 250 volts AC 3 wire, single phase

Amps: 20 amp circuit 60 cycle

Wattage:

Standby: -0-

Idle: 375 watts

Operating: 3500 watts

Output: 1300 watts (for measured output see
Table 3.11)

FIGURE 3.11 DESCRIPTION AND OPERATING SPECIFICATIONS
OF THE COMMERCIAL MICROWAVE OVEN USED
IN ELECTRIC FIELD DISTRIBUTION MEASUREMENT
STUDY

are absorbed by a pound of distilled water which has been heated for sixty seconds in a Pyrex glass beaker (one-liter size). The conversion formula is: cooking watts/hour = 1 pound H_2O x Δt F x 60 (1 min. heating)/3.413.

In addition to using the procedure outlined in Method Number Six, the glass beaker was oriented in the same manner for each replication and position tested in the oven. The three positions tested in the oven were: the left rear corner, the center and the right center. They are shown in Figure 3.12. The left rear corner and right center positions were checked for wattage output based on preliminary investigations which indicated that these positions were the extremes for electric field distribution in the microwave oven being used. The center location is normally prescribed for wattage output determination of a microwave oven. The results of the wattage output tests are given in Table 3.11. The range in measured wattage output was from 12.1 to 18.9 per cent below the rated output of 1300 watts stated by the manufacturer.

3.2 Experiment II. Selecting a Low Dielectric Loss Substance to be Used as a Vehicle for Measuring Electric Field Distribution

Previous studies have been directed toward locating concentrations of microwave energy in a single plane within the oven cavity. Wilhelm and Satterlee (1971) proposed a 3-dimensional method of mapping microwave ovens. The procedure involved separate microwave heating exposures at

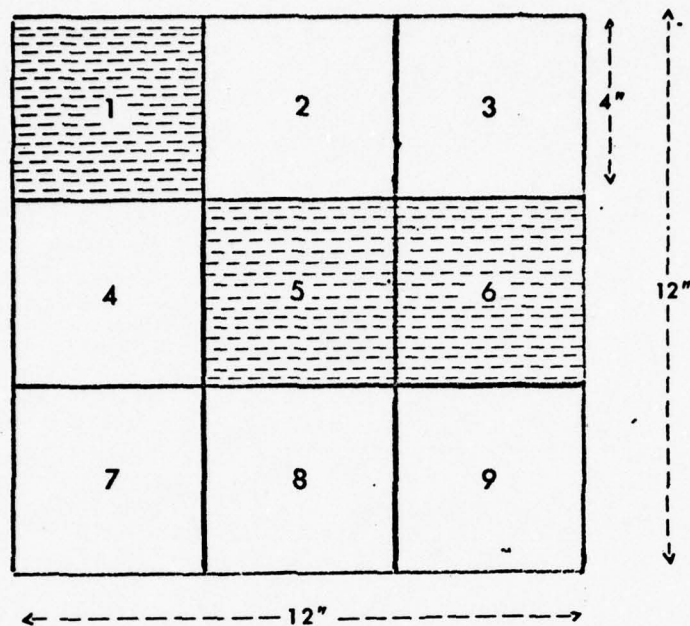

FIGURE 3.12 THE THREE SHADED POSITIONS REPRESENT THE AREAS OF A MICROWAVE OVEN CHECKED FOR OUTPUT WATTAGE

TABLE 3.11 OUTPUT WATTAGE FOR THREE DIFFERENT POSITIONS
IN A MICROWAVE OVEN RATED AT 1300 WATTS

REPLICATIONS	OUTPUT WATTAGE		
	Area #1	Area #5	Area #6
1	1055	1090	1143
2	1055	1090	1143
3	1055	1090	1143
4	1055	1090	1143
5	1055	1090	1143

various oven planes, thereby assembling a collection of horizontal modes for electric field concentration determination. The major shortcoming of this experiment was the lack of information about planes between those charted and the possible electric field perturbation caused by elevation changes of the measurement vehicle.

The purpose of this experiment was to find a low dielectric loss material that could be used as a vehicle for suspending a biological substance which, when exposed to heat in a microwave oven, could be used to measure the energy distribution patterns. Glass, most ceramics, paper, cardboard, wood and most plastics are partially transparent to microwave energy (Daly, 1973). Isomica, fused silica, petroleum wax, foam polystyrene, benzine and oven films were listed as being microwave transparent. The requirements for the material being sought were minimal dielectric loss properties, an open or matrix type texture to allow a visual capability for observing reactions, and a structure that would facilitate chemical impregnation. Spun fiber glass appeared to have these qualities; however the dielectric loss properties were unknown.

Close examination of the fiber glass revealed that an oily substance was present. To preclude energy absorption, the oil was removed using hexane (Skelly B). The fiber glass was washed three successive times to remove all traces of oil residue. The fiber glass was allowed to air dry one-half hour after which all traces of hexane odor

were no longer evident. Using a shears, the fiber glass was cut into 12 x 12 inch sheets, which were one inch thick. Because of the "springy" characteristics of the fiber glass, a glass template of the exact size was placed on the matrix sheets to compress them for ease in cutting, as well as to add a measure of preciseness and uniformity to all the fiber glass sheets.

The fiber glass had a matted layer on both the top and bottom of each sheet. This gave a concentration of fibers on both surfaces and would subsequently provide an increased surface area for the glucose/glycine solution which was to be used in the process of measuring the electric field distribution. The matted layers were easily peeled from the matrix since the fiber glass was a collection of cohesive sheets built up to provide thickness. The removal of successive layers was also beneficial in adjusting the individual sheet to achieve a uniform weight. Each sheet was adjusted to weigh 8.2 g.

To determine the dielectric loss properties of the fiber glass after the oil was removed, 50 ml of distilled water were heated in the oven for 10 seconds in a 400 ml styrofoam container positioned in the center of the oven cavity at shelf (floor) level. The mean Δt in degrees F of the water for six replications was to provide a basis for comparison when the water and dry untreated fiber glass were heated in the oven. The net decrease in mean temperature when the water and fiber glass were heated in the oven

together compared to when the water was heated alone was assumed to indicate the approximate amount of energy absorbed by the fiber glass. Figure 3.21 shows the relative location of the fiber glass in relationship to the container of water. To place the container of water in the precise location that was used for heating the water alone, the center portions of the bottom two layers of fiber glass were removed to accommodate the water container. This represented 12.5 cubic inches of the total 720 cubic inches being exposed, or 2 per cent. The temperature increases for six replications, both with and without the fiber glass in the oven are shown in Table 3.21. The difference between the two means (0.3 F) was not significant according to Gossets' Student t test where;

$$t = (\bar{y}_1 - \bar{y}_2) - D_0 / s \sqrt{1/n_1 + 1/n_2}$$

and

$$s^2 = \frac{\sum_{i=1}^{n_1} (y_i - \bar{y}_1)^2}{n_1} + \frac{\sum_{i=1}^{n_2} (y_i - \bar{y}_2)^2}{n_2} / (n_1 + n_2 - 2).$$

Based on the findings of this experiment, the fiber glass met the requirements of a low dielectric loss material, so a decision was made to use this matrix as a vehicle for measuring electric field distribution in the microwave oven.

3.3 Experiment III. Using the Non-Enzymatic Browning Reaction in a Model System to Measure Electric Field Distribution

Studies on electric field distribution in the past have involved complex food systems which were subjectively evaluated.

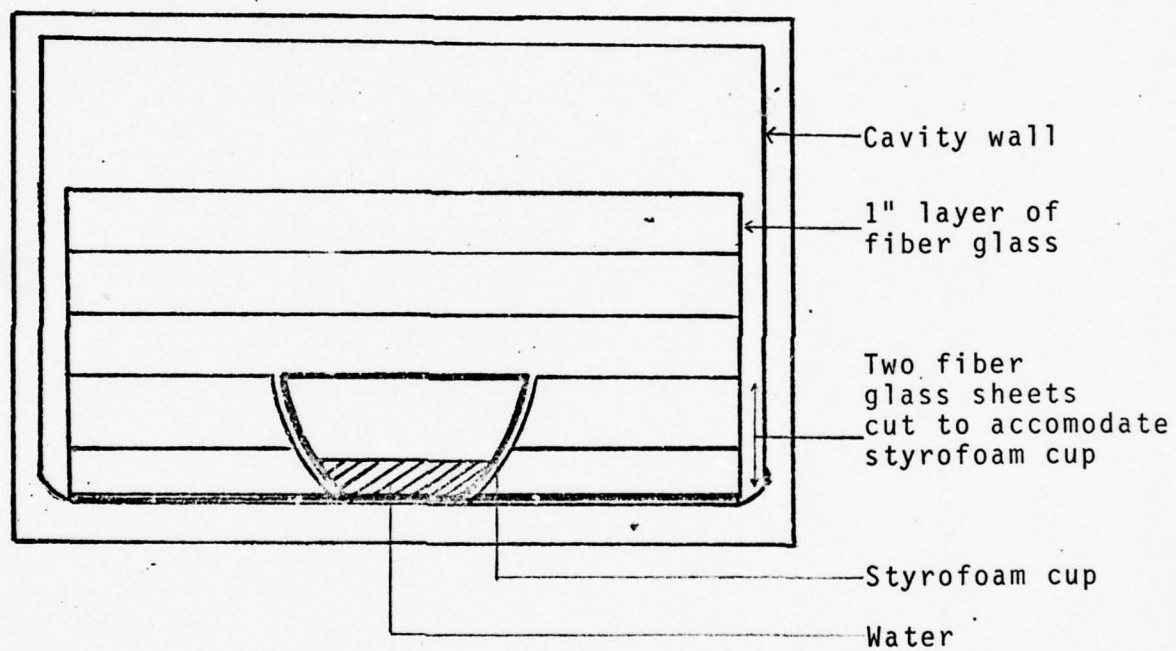

FIGURE 3.21 RELATIVE LOCATION OF THE WATER CONTAINER AND FIBER GLASS IN A MICROWAVE OVEN DURING DIELECTRIC LOSS EXPERIMENTS

TABLE 3.21 TEMPERATURE INCREASE OF 50 ML OF WATER
HEATED FOR 10 SECONDS IN A MICROWAVE OVEN
WITH AND WITHOUT FIBER GLASS PRESENT

REPLICATION	WATER Δt F	WATER AND FIBER GLASS Δt F
1	54	55
2	55	54
3	54	56
4	55	55
5	55	54
6	54	55
\bar{y}	54.5	54.8

Peterson and Foerstner (1971) studied the cooking performance of microwave ovens using five different food items. Each was evaluated subjectively for color, texture, appearance and other "unusual" characteristics such as rifts or cracks. Objective evaluation was limited to weight loss and temperature differential within and among food items. This method shows that uneven heating occurs, but the location and level of the energy concentration were not specifically identified.

The purpose of this experiment was to examine the non-enzymatic browning reaction which, among other factors, has a correlation to heat energy and hence could provide a measure of electric field distribution in a microwave oven.

3.31 The Non-Enzymatic Browning Reaction in a Model System

Hodge (1953) provided a detailed review of literature of the browning reaction in model systems whereby reducing sugars and amines condense in equimolar ratio to form color. The reported mechanism for sugar-amine condensation involves opening of the ring form of the sugar, addition of the amine to the carbonyl group, and subsequent elimination of a molecule of water to form the N-substituted glycosylamine during the initial phase of the browning reaction. The reaction occurs in three stages. The initial stage consists of the sugar-amine condensation and Amadori rearrangement. In the intermediate stage the sugar undergoes dehydration and fragmentation, concurrent with amino acid degradation. The final stage consists of aldol condensation, aldehyde-amine polymerization and formation of heterocyclic

nitrogen compounds. The carboxylamine reaction is favored by alkaline conditions (Hodge 1953). According to Labuza (1972), the temperature for the reaction rate is exponentially related:

$$\text{Log } K_1/K_2 = E_a/R(1/T_1 - 1/T_2)$$

where

- K_1, K_2 = reaction rate constants
 E_a = Arrhenius activation energy = 25,000-50,000 cal/mole.
 R = universal gas law constant = 1.986 cal/mole K
 T_1, T_2 = temperature in degrees K.

The general plot of the reaction is in Figure 3.311. The exponential relationship of the reaction rate to the temperature was considered a major factor that would accent electric field concentrations.

3.32 Procedure For Making Glucose/Glycine Solution

Glucose and glycine were selected as the sugar and amino acid for the model system. Studies were conducted using a five per cent glucose/glycine mixture (2.5% each) buffered to pH 9.1 with Na_2PO_4 and NaOH, with distilled water as the solvent. Although heating this solution in a microwave oven produced some browning, the reaction rate and degree of color formation were considered inadequate for electric field measurement for this study.

The reaction rate and color formation during heating in the microwave oven were improved with further formulation tests. The concentrations of glucose and glycine were increased to 12.5% each for a combined 25% concentration of

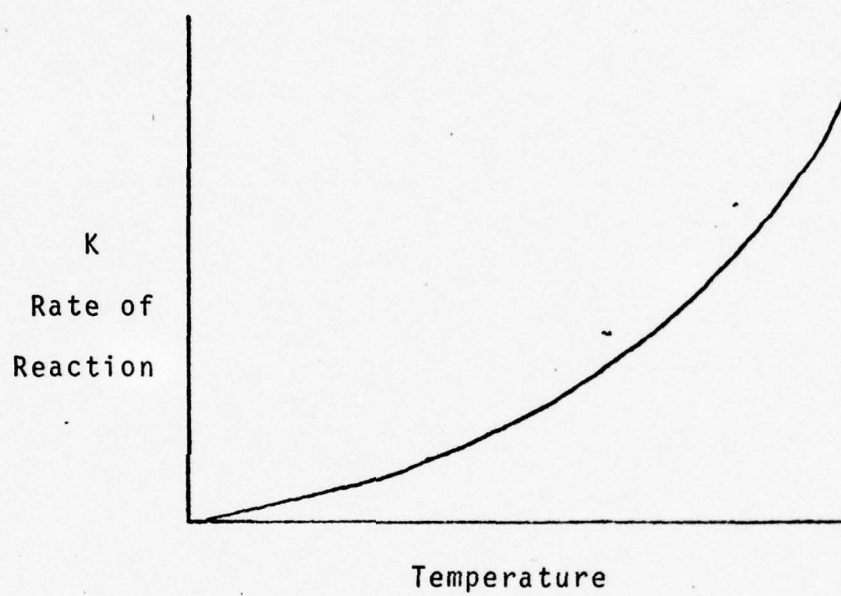

FIGURE 3.311 NON-ENZYMATIC BROWNING REACTION RATE IN RELATIONSHIP TO TEMPERATURE

both compounds by weight, with a resulting pH of 8.4 using the same buffer and alkali compounds. A 2% pre-gelatinized starch was also added to increase the retention of the solution on the matrix. This proved undesirable and caused matting of the matrix because of the increased volume of solution retained. The starch was subsequently eliminated and the following formulation appeared to provide optimal reaction rate, color formation and matrix solution retention:

125 g glucose, 125 g glycine, 750 ml distilled water @ 20 C, 1.4 g Na_2PO_4 and 2.2 g NaOH, with final pH at 8.4.

An optimal reaction rate was determined based on combination of color formation and ending weight of the fiber glass sheet. The ending weight was a critical factor in providing underload protection during the terminal minutes of microwave heating. Thirty-five to 50 grams of glucose/glycine solution as final weight was estimated to provide this protection. Each of five fiber glass sheets described in Chapter 3.2, was impregnated with 13.3 g of the 25% glucose/glycine solution using a chromatography sprayer. To observe color changes and to determine weight loss, the combined assemblage of five fiber glass sheets containing a total of 66.5 g of glucose/glycine solution were heated in the microwave oven using an interrupted, 30 second heating sequence. After three minutes of cumulative heating time, there was a discernible color and a solution ending weight of 20 g for the fiber glass assemblage. Although areas of intense electric field concentrations were visually

apparent as measured by the browning reaction, areas with a lesser concentration of microwave energy did not register the gradation of color which would provide a measurable comparison among areas and levels. An additional experiment was conducted whereby the weight of the solution retained in each fiber glass sheet was increased by 10.7 g to 24 g, and the exposure time to microwave energy was increased to 4.5 minutes. This provided a color gradation between areas of varying electric field intensity as well as an adequate ending weight (35 g) for underload protection to the megatron.

3.4 Experiment IV. Procedure For Measuring Electric Field Distribution in a Microwave Oven

Literature was consistent in emphasizing that uneven electric field concentration in microwave ovens is a problem and measurement of the energy distribution continues to plague the industry. Kumpfer (1972) stated that the achievement of an acceptable energy pattern is usually one of the most important and difficult problems which the designer faces. Wilhelm and Satterlee (1971) pointed out that before today's consumer can become satisfied with microwave cookery, it will be absolutely essential to become familiar with the peculiar cooking patterns of the oven. This becomes even more critical when conducting research on food items heated in microwave ovens to insure that electric field concentrations do not interject an unplanned variable. Tracy (1974) found that electric field concentrations affected

the relative quality of food when heated in areas of high electric field concentration.

The purpose of this experiment was to chart electric field concentrations of a specific microwave oven and evaluate the reliability of the procedure. The general procedure involved fiber glass matrix and glucose/glycine preparation, impregnation of the solution into the matrix, microwave heating of the matrix, sampling, matrix extraction of the browning reaction and evaluation of the browning reaction.

The portion of the microwave oven selected for study measured 12 x 12 x 5 inches. The 12 x 12 inch area represented the usable cavity floor space. The five inches in height approximated the maximum that any portioned prepared food would attain during heating.

3.41 Glucose/Glycine Impregnation Procedure

A 25% glucose/glycine solution described in Chapter 3.3, Experiment III, was placed in a JET-PAK¹ spraying device. Each individual pre-cut fiber glass sheet as described in Chapter 3.2, Experiment II, was placed against a stainless steel wire rack in an upright position to allow a free flow of spray through the matrix. Spraying of the individual sheets (five for each replication) was accomplished by

¹JET-PAK Sprayon Products, Inc. Cleveland, Ohio. This device is commonly used for spraying thin-layer chromatography plates and uses Dichlorodifluoromethane as a propellant.

using a sweeping overlapping motion often described for spray painting. After one side was completed, the sheet was turned one-quarter turn, reversed and sprayed on the opposite side in the same manner. Approximately 30 ml of solution were needed to spray each fiber glass sheet to achieve 24 g retention. The spraying device was held approximately six inches from the material being sprayed. When both sides had been sprayed, a weight check was made to determine if additional solution was required. If additional solution was required, the spraying device was held approximately 12 inches from the matrix and one side was re-sprayed in a broader pattern than previously used. This allowed for addition of small quantities of solution uniformly throughout the matrix. Each sheet was sprayed in this manner to an ending gross weight of 32.2 g. This gross weight provided a net solution weight of 24 g or a total of 120 g of glucose/glycine solution for the five sheet assemblage.

When each sheet of fiber glass was impregnated with the solution, it was placed in a container to minimize evaporation. The sprayed sheets were stacked as each successive sheet was treated. Approximately six minutes were required to spray the five fiber glass sheets. Evaporation losses prior to microwave heating were estimated to be less than one gram per sheet.

After the five sheets had been sprayed to the appropriate weight, a dry, unsprayed thin fiber glass sheet, previously removed from the surface of the matrix, was placed at the

bottom of the assemblage to provide a thin inert separation of the sprayed fiber glass and oven shelf. The purpose of this thin sheet was to minimize conduction heating caused by the dielectric heating of the shelf. The shelf "heating" also causes the sprayed fiber glass to stick to the shelf, or burn-on, during microwave heating. The thin inert layer separating the oven shelf and the testing media minimized this effect.

3.42 Microwave Heating of the Test Media

To provide a warm-up for the oven prior to microwave heating of the assemblage of treated fiber glass sheets, 100 ml of water were heated for 30 seconds. The impregnated fiber glass was then placed in the oven and the oven activated for 90 second periods for a total cumulative time of 4.5 minutes. A stop watch was used for all time sequences; 15 seconds was a standard "rest" time between each of the three 90 second heating exposures. The 4.5 minutes of heating was based on the results of preliminary experiments described in Chapter 3.32. Height measurements of the fiber glass assemblage before and after microwave heating indicated that no change in height occurred during heating.

At the completion of the 4.5 minute exposure, the five sheets were removed from the oven and separated. The thin inert sheet was removed from the bottom layer and discarded.

It should be noted that before the solution was sprayed into the five sheets, the overall height was five inches.

However, after spraying, the weight of the solution caused a compression of the bottom three layers in a progressively increasing amount. The upper two layers of fiber glass assemblage remained unchanged after solution impregnation. The lower three layers decreased in thickness from their original one inch to three-fourths, one-half, and one-quarter inch respectively. Preliminary experiments which were conducted using the same grade and quality of fiber glass (according to the label), had a matted layer on only one surface as compared with both surfaces being matted on the fiber glass used for the experiments in the data collection phase of this study. The removal of both surfaces apparently caused a reduced strength of the matrix and subsequent compression of the lower level sheets during the data collection phase. In spite of the fact that this resulted in an obvious concentration of solution in the lower oven levels as compared with the upper levels, it was not considered a factor that influenced the measurement of energy concentrations. No compression effect was experienced during preliminary experiments yet the same general pattern of energy distribution was visually apparent.

3.43 Sample Design and Analysis

Consultation with a statistician indicated that for statistical analysis, each of the five levels tested in the microwave oven should be divided into nine areas. Consideration was given to dividing each level into yet smaller areas

to provide a more refined evaluation; however the 4 x 4 inch areas were used since they represented areas normally occupied by portioned food items when heated in a microwave oven. The total usable space of the microwave oven cavity studied measured 12 x 12 x 7 5/16 inches. The cavity space of interest in this study was only that cubic volume where pre-portioned food items are heated; thus, for this oven the established parameters for study were 12 x 12 x 5 inches. Although portioned food would seldom attain five inches in height, stacking individual servings of food items in the oven cavity while heating is a common practice.

A three-factor design was used for statistical analysis where the effects are additive according to the formula:

$$Y_{ijkl} = u + R_i + L_j + RL_{ij} + A_k + RA_{ik} + RLA_{ijk} + e(ijk)l$$

where

$$i = 1, 2, 3$$

$$j = 1, 2, \dots, 5$$

$$k = 1, 2, \dots, 9$$

$$l = 1$$

u = overall population effect

R_i = effect of i th replication (a random effect)

L_j = effect of j th level (a fixed effect)

RL_{ij} = effect of interaction of i th replication and j th level

A_k = effect of k th area (a fixed effect)

RA_{ik} = effect of interaction of i th replication and k th area

LA_{jk} = effect of interaction of j th level and k th area

RLA_{ijk} = effect of interaction of i th replication, j th level and the k th area

$e(ijk)l$ = random error assumed to be distributed normal with mean zero and variance σ_e^2

In accordance with the preceding statistical design, each of the 45 cells was assigned an identification number as shown in Figure 3.431.

3.44 Matrix Extraction and Sample Dilution Procedure

Immediately upon removal from the oven after microwave heating, the five individual sheets of fiber glass were separated and each cut with a shears into nine samples. There was some loss of the browning reaction material in the areas where the shears separated the cells, however this loss was minimal and uniform between experiments as measured by weight for each experiment (<0.2 g). The identity of each cell was retained by attaching a small piece of masking tape with the appropriate coding information.

After identification and separation of the 45 fiber glass sample cells, each sample was placed in a 250 ml beaker. In order that each fiber glass sample would fit into the beaker, the sample was cut into smaller pieces using shears. The cutting was done over the beaker so that any browning reaction fall-out from the matrix would be retained as part of the sample. After cutting, 50 ml of distilled water were added to the sample in the beaker and the fiber glass was allowed to soak for a minimum of two minutes. The water temperature for all extractions was 20 C. A stainless steel spatula was used to depress the

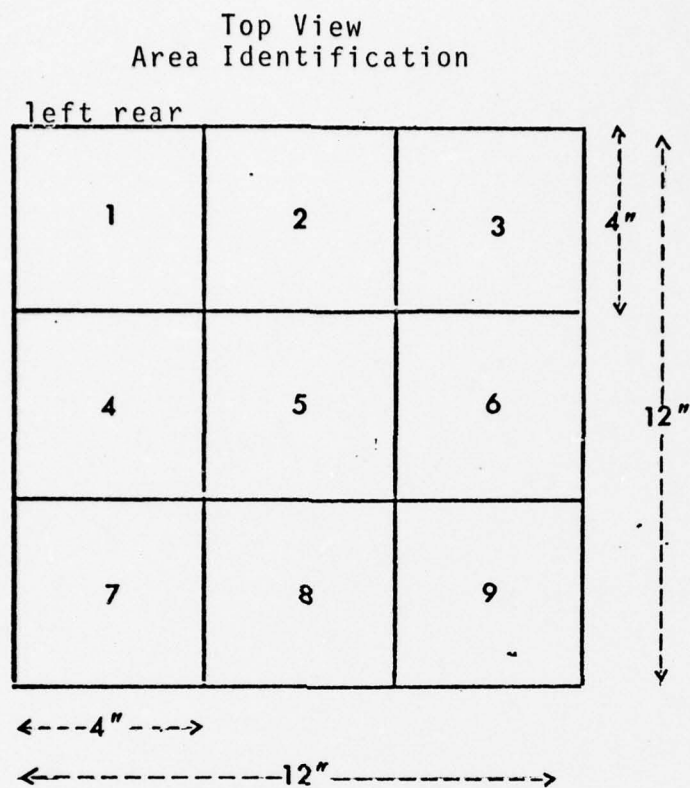

End View
Level Identification*

E Level (upper level)
D Level
C Level
B Level,
A Level (bottom)

FIGURE 3.431 LEVEL AND AREA IDENTIFICATION OF 45 INDIVIDUAL CELLS USED FOR MEASURING ELECTRIC FIELD DISTRIBUTION IN A MICROWAVE OVEN

fiber glass and insure total submersion in the water. The sample was then decanted into another 250 ml beaker, with the fiber glass being retained in the original beaker for additional extractions. While decanting, the fiber glass was depressed with the spatula to extract the maximum amount of effluent. Three additional extractions were made for each sample using 25 ml for each subsequent extraction with the effluent being added to the original effluent. The last washing provided complete removal of all visible browning reaction with the fiber glass reverting to its original white appearance. Fifty ml of water were used for the first washing because the matrix was dry and the majority of the browning reaction was removed with this washing. The three subsequent extractions for each sample, using 25 ml per washing, were needed for the areas of severe browning, and this procedure was used for all areas to insure uniformity of dilution for all samples.

Since the effluent extracted from the sample cells contained small particles of fiber glass that could affect spectrophotometric analysis, the samples were gravity filtered using #42 filter paper.

The dark colored samples were diluted using 20 C distilled water so that the color could be effectively measured by the spectrophotometer within the range of 0.2 to 0.9 absorption units at 310 nanometer (nm). The wavelength setting was based on a wavelength scan for maximum absorption units of reacted samples (light yellow to dark brown)

over the range of 290 nm to 500 nm. The samples were scanned on the Beckman DB-6 Grating Spectrophotometer and the Beckman ACTATM III Spectrophotometer with maximum absorption for the tested samples occurring at 310 nm on both instruments.

3.45 Spectrophotometer Analysis

After the effluent extracted from each sample cell was diluted as described in Chapter 3.44, it was measured for color using the Beckman ACTATM III UV-Visible Spectrophotometer. A design feature included wavelength scanning which was used to determine the nanometer where maximum light energy absorption occurred for the glucose/glycine solution extracted from the fiber glass matrix after microwave heating. Two color extremes were selected for wavelength scanning, light yellow and dark amber. The results of the wavelength scan are shown in Figures 3.451 and 3.452. The yellow sample reached a maximum absorbency peak at 310 nm, whereas the dark amber sample exhibited maximum absorption between 330-310 nm. Based on the results of the wavelength scan, a decision was made to test all samples for absorbency at 310 nm. The samples with color development falling between the two extremes were assumed to exhibit the same absorbency characteristics.

The instrument was adjusted for split-beam operation and the unreacted or original glucose/glycine solution was used as a reference sample. A digital display provided

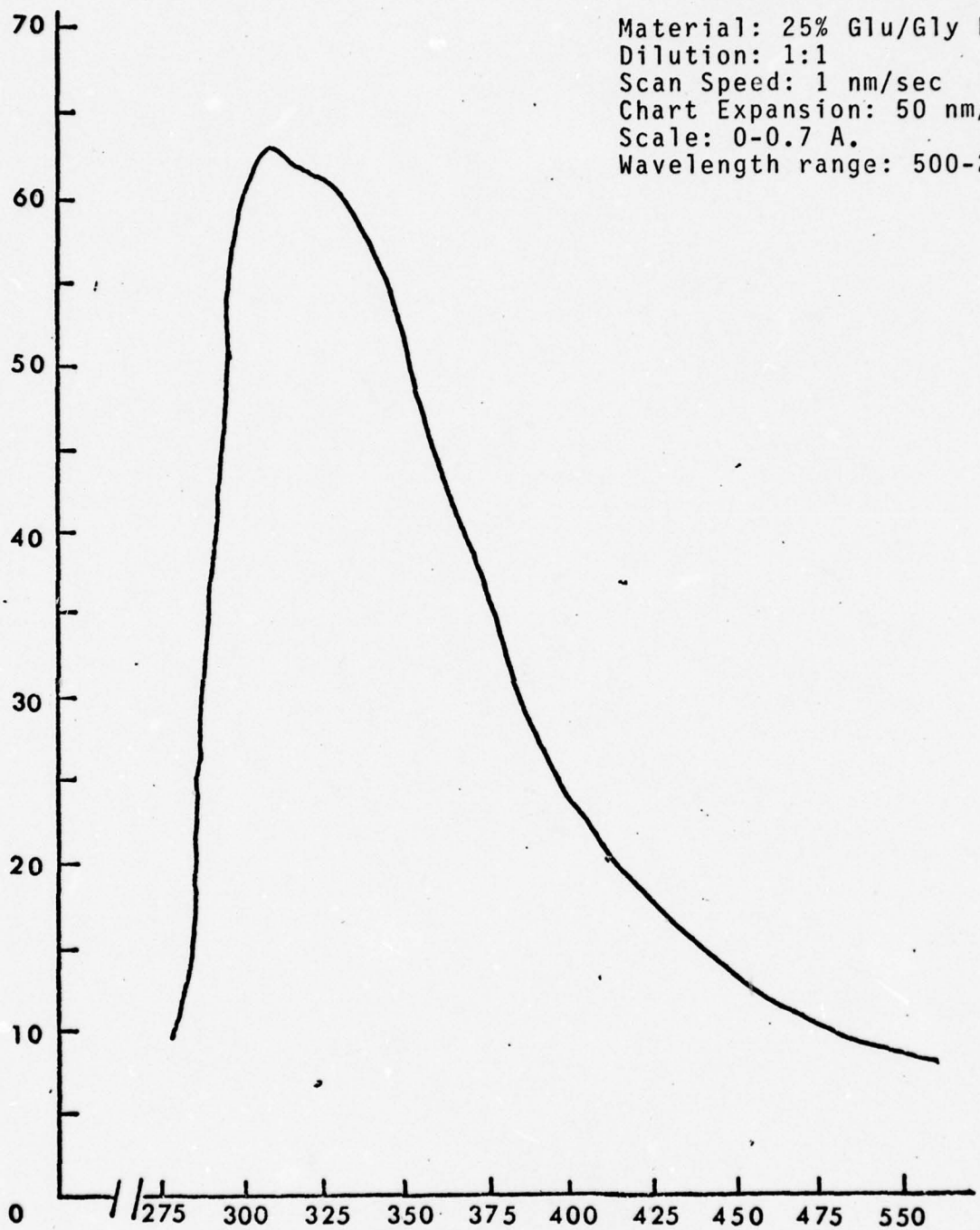

FIGURE 3.451 WAVELENGTH SCAN OF MICROWAVE HEATED GLUCOSE/
GLYCINE EXTRACTION: LIGHT YELLOW

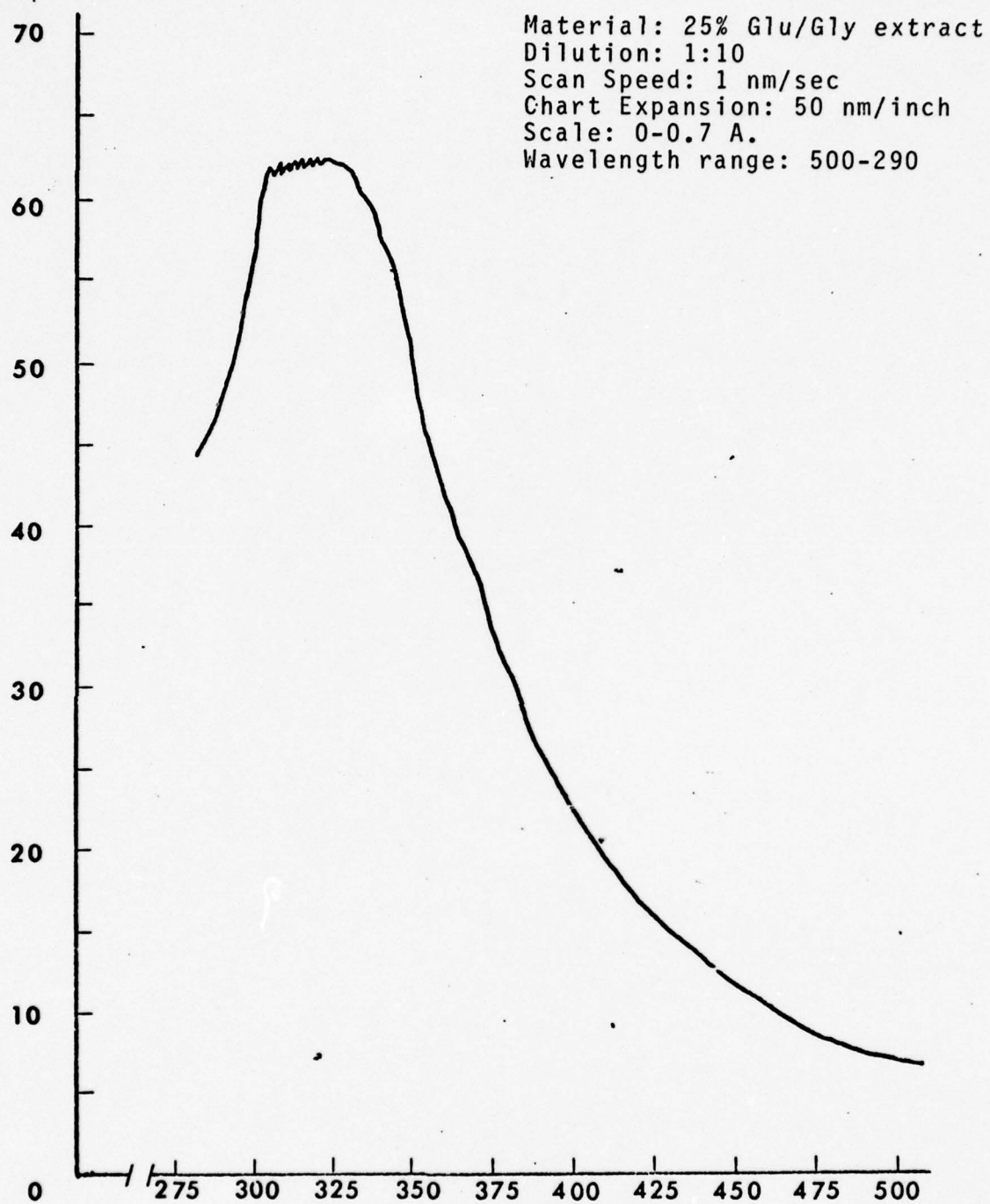

FIGURE 3.452 WAVELENGTH SCAN OF MICROWAVE HEATED GLUCOSE/
GLYCINE EXTRACTION: DARK AMBER

a four digit decimal value. Values between 0.200 and 0.900 absorbency units were considered optimal for maximum accuracy. Samples taken from low electric field concentrations which had values less than 0.200 absorption units were not diluted and direct reading values were recorded. Diluted sample readings were multiplied by the dilution factor for the actual sample value. Sample values ranged from 0.000 to 21.378 absorption units.

CHAPTER 4

RESULTS AND DISCUSSION

Data recorded from the absorbency measurements for the browning reaction in 45 sample cells of the fiber glass matrix measuring 12 x 12 x 3½ inches were tabulated (Appendix, Table 1). The second dilution of several samples was necessary when absorbency units exceeded the maximum optimal reading of 0.900 on the spectrophotometer digital display. Zero values represented sample readings equal to or less than the reference sample absorbency.

The range, mean and variance of the data collected are listed in Appendix Table 2. The original data for cells A4, A6, B4, B5, B6 and C6 show a wide range in absorbency units among replications. The high variance for these cells contributed to the heterogeneity of the original data. Appendix Tables 3 and 4 show the estimates of treatment means for the nine areas and five levels of the extracted browning reaction from the fiber glass matrix. The right center grid (Area #6) of the microwave oven tested had the highest absorbency value for the browning reaction, with the left rear (Area #1) measuring the lowest. Among levels, the bottom (Level A) electric field intensity as measured by the browning reaction was approximately 10 times greater

than the top level (Level E).

4.1 Analysis of Data

The valid application of tests of significance in the analysis of variance requires that the experimental errors be independently and normally distributed with a common variance (Steel and Torrie, 1960). While independence is of lesser concern here, any violation of homogeneity of variances can have serious consequences on the analysis. To determine whether population variances were homogeneous, the Q-test for equality of variance, based on three replications, was performed. The Q-test statistic (Burr, 1972) is:

$$q = (s_1^4 + \dots + s_p^4) / (s_1^2 + \dots + s_p^2)^2$$

where

$$s_i^2 = \frac{1}{2}(y_i - \bar{y})^2$$

$$s_i^4 = (s_i^2)^2$$

The test of homogeneity indicated that the observations for Levels A, B, and C were not homogeneous. Consequently, the standard deviations, based on the pooled error mean square, would be too large for comparison among levels and might fail to detect real differences in level or area effects. The data were subsequently measured on a new scale by transformation $\sqrt{X + .5}$, which is recommended when some of the values are under 10 and especially when zeros are present (Steel and Torrie, 1960). The transformed

data were homogeneous. The q-values for the transformed and original data are shown in Table 4.11.

Analysis of variance was performed on the transformed and the original data using the program LLSP-1 written for the IBM 1620 computer provided by the College of Agricultural and Life Sciences Computing Center. This was done to test the hypotheses that there are no differences in the electric field distribution patterns among five heating levels and nine heating areas of the microwave oven. Effects due to Replication and Level were tested by comparing their respective mean squares against that for Error_(a). The effect due to Area and the effect of the Level x Area interaction were tested by comparing their respective mean squares against that for Error_(b). Standard F-tests were employed (Steel and Torrie, 1960). The analysis of variance of the original data was compared to the analysis of variance for the transformed data. All tests of significance were the same. Because of its homogeneity the transformed data were used for all subsequent analyses.

4.2 Results of the Analysis

The results of the analyses of variance are in Tables 4.21 and 4.22. Table 4.21 shows that Replication was not significant at the 5 per cent level, indicating the method was reliable. There were significant Level and Area main effects and a Level x Area interaction effect; this indicated uneven electric field distribution among areas and levels.

TABLE 4.11 Q-TEST VALUES FOR ORIGINAL AND TRANSFORMED
ABSORBENCY UNITS FOR THE BROWNING REACTION
COLLECTED FROM 45 SAMPLE CELLS OF FIBER GLASS
EXPOSED IN A MICROWAVE OVEN

LEVEL	ORIGINAL Q-VALUE	TRANSFORMED Q-VALUE $\sqrt{X + .5}$
A	.318*	.243
B	.382**	.270
C	.349*	.242
D	.171	.141
E	.185	.161

* Significant at the 5% level

** Significant at the 1% level

TABLE 4.21 ANALYSIS OF VARIANCE OF ABSORBENCY UNITS FOR
 THE BROWNING REACTION COLLECTED FROM 45 SAMPLE
 CELLS OF FIBER GLASS USED TO MEASURE ELECTRIC
 FIELD DISTRIBUTION IN A MICROWAVE OVEN:
 TRANSFORMED $\sqrt{X + .5}$

SOURCE	df	SUM OF SQUARES	MEAN SQUARE	F
Replication	2	0.02345	0.01173	0.011
Level	4	41.81370	10.45344	9.73**
(R x L) E _a	8	8.59403	1.07425	--
Area	8	45.71615	5.71452	68.80**
Level x Area	32	15.46360	0.48324	5.82**
E _b	80	6.64507	0.08306	--

** Significant at the 1% level

TABLE 4.22 ANALYSIS OF VARIANCE OF ABSORBENCY UNITS FOR
 THE BROWNING REACTION COLLECTED FROM 45 SAMPLE
 CELLS OF FIBER GLASS USED TO MEASURE ELECTRIC
 FIELD DISTRIBUTION IN A MICROWAVE OVEN:
 ORIGINAL DATA

SOURCE	df	SUM OF SQUARES	MEAN SQUARE	F
Replication	2	8.48	4.24	.16
Level	4	833.57	208.39	7.63**
(R x L) E _a	8	218.53	27.32	--
Area	8	879.29	109.91	34.67**
Level x Area	32	480.71	15.02	4.74**
E _b	80	253.64	3.17	--

** Significant at the 1% level

Although the analysis of variance showed that there was a significant difference among levels, that analysis per se did not indicate the areas of the oven that contributed to the differences. Duncan's new multiple-range test was used to determine, for each area, significant differences among means for the five levels (Steel and Torrie, 1960). This test was used because it takes into account the number of treatments in the experiment, permits decisions as to which differences are significant and which are not and uses a set of significant ranges, each depending upon the number of means in the comparison. The results of the multiple-range test are shown in Table 4.23.

4.3 Discussion

The nine areas and five levels studied in the microwave oven (Table 3.431) showed a considerable variation in energy concentration as measured by the non-enzymatic browning reaction. The rear 1/3 of the oven at all levels (Area 1, 2, and 3) showed a relatively uniform distribution of microwave energy, although the intensity of the electric field was much less when compared with other areas of the cavity tested. See Table 4.23. Area #6 exhibited the greatest range in electric field distribution with a significant difference among levels C, D, and E. There was no difference between Levels A and B but they were significantly different from Levels C, D, and E. There was a more uniform energy distribution pattern in the upper

TABLE 4.23 SIGNIFICANT DIFFERENCES BETWEEN ABSORBENCY UNIT MEANS IN EACH OF THE FIVE LEVELS FOR EACH OF THE AREAS STUDIED IN A MICROWAVE OVEN*

AREA	MEANS OF LEVELS TRANSFORMED $\sqrt{X + .5}$				
	E‡	D	C	B	A
1	<u>0.821</u>	1.065	1.081	1.156	1.267
2	<u>0.871</u>	0.993	1.155	1.217	1.378
3	<u>0.956</u>	1.140	1.140	<u>1.384</u>	1.660
4	<u>1.188</u>	<u>1.474</u>	2.013	<u>3.086</u>	<u>3.155</u>
5	0.952	<u>1.733</u>	<u>2.153</u>	2.706	3.303
6	1.297	1.853	3.058	<u>3.884</u>	<u>4.001</u>
7	<u>1.246</u>	<u>1.634</u>	<u>1.942</u>	<u>2.347</u>	<u>2.591</u>
8	1.214	<u>2.034</u>	<u>2.459</u>	<u>2.987</u>	<u>3.221</u>
9	1.238	<u>1.763</u>	<u>2.306</u>	<u>2.692</u>	<u>3.242</u>

* Values not underscored by the same line differ significantly at the 5% level

‡ Indicates level identification

levels of the areas of the microwave oven cavity studied. However the overall electric field in the upper levels was less intense than in the lower levels. When comparing means, the lower three levels (A, B, and C) had the greatest range and highest intensity of microwave energy. These are also the levels that include the part of the cavity where the majority of portioned foods would be heated.

There was a significant (at the 5 per cent level) Level x Area interaction. See Table 4.21. This was not entirely unexpected. In Figure 4.31 the Level x Area interaction effect is exhibited. The electric field concentration behavior for each of the five levels is, in general, similar over Areas 5, 6, 7, 8 and 9. However, over Areas 1, 2, 3 and 4, Level B exhibits a markedly different behavior from that of other levels. Between Areas 4 and 5, Levels B and E behaved in a manner opposite (decreasing) from the way all other levels behaved (increasing).

To further substantiate the level and area differences shown by statistical analysis, photographs of the fiber glass matrix heated in a microwave oven are shown in Figure 4.32. The difference among levels and areas is visually apparent. As the distance upwards from the shelf increased, the electric field intensity decreased; however the relative distribution of energy among areas remained unchanged. Area #1, for example was the cold spot in each of the five levels and Area #6 was the hot spot as measured by the browning reaction. These extremes in electric field distribution

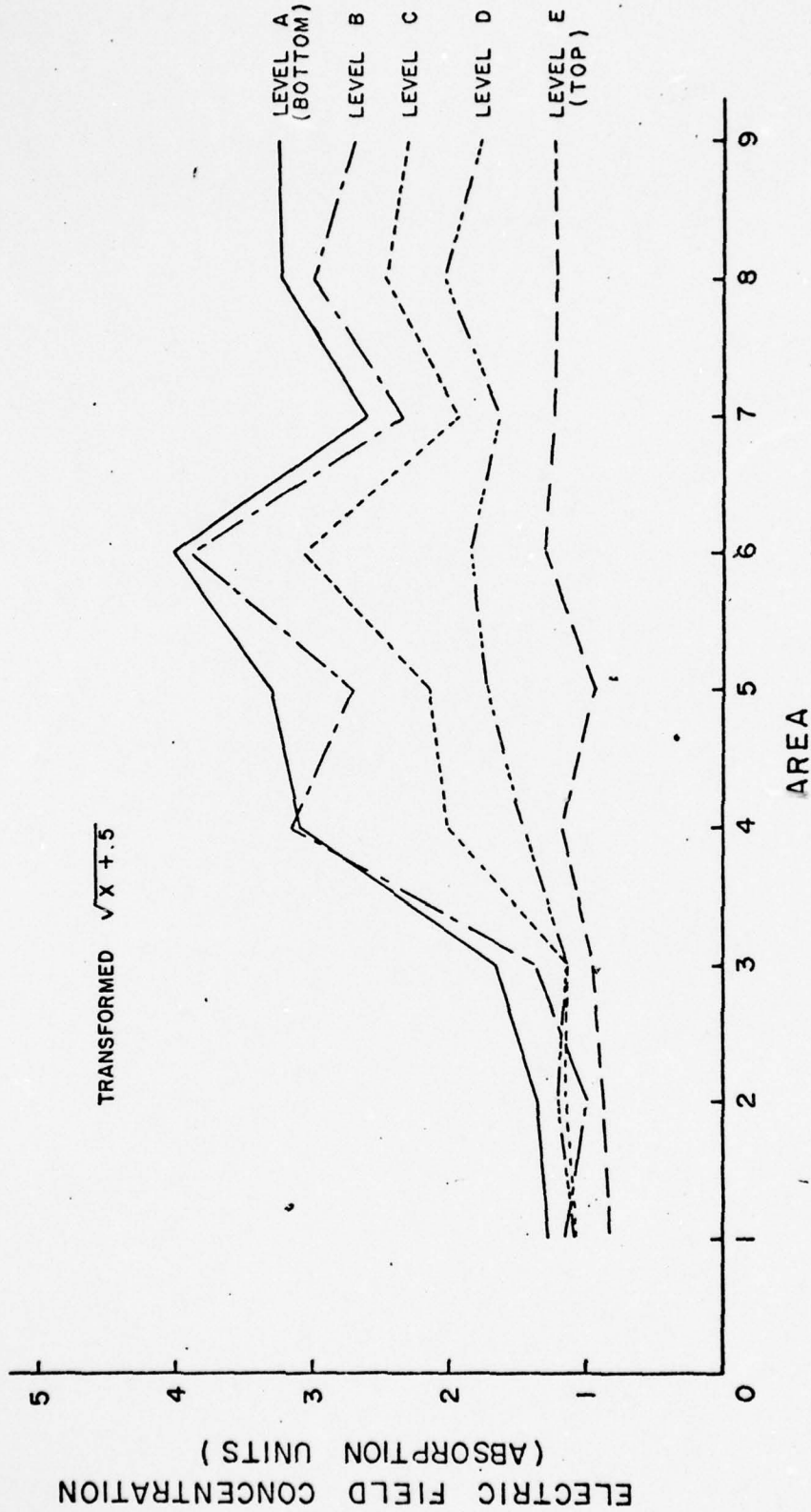
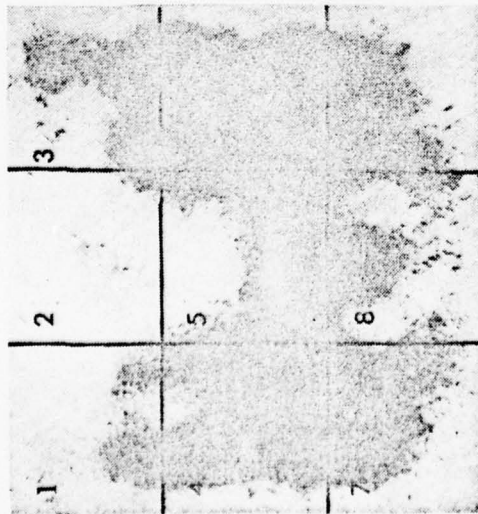
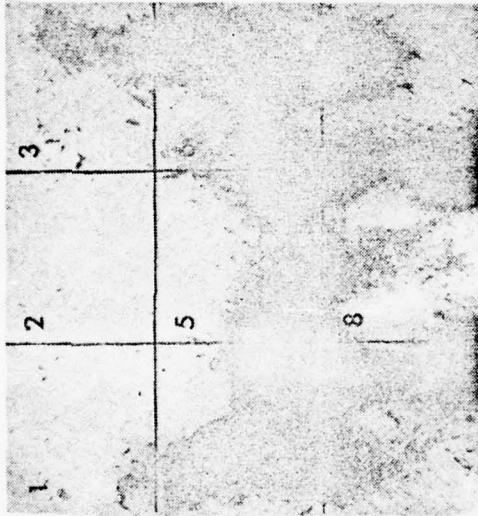

FIGURE 4.31 INTERACTION OF LEVELS AND AREAS FOR ELECTRIC FIELD CONCENTRATION IN A MICROWAVE OVEN



Right Front
Level A



Right Front
Level B

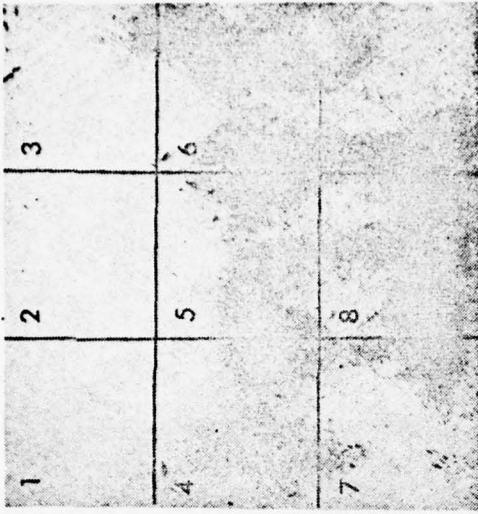

Right Front
Level C

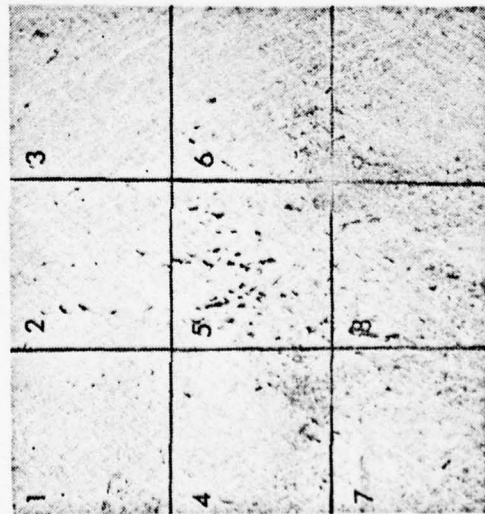

Right Front
Level D

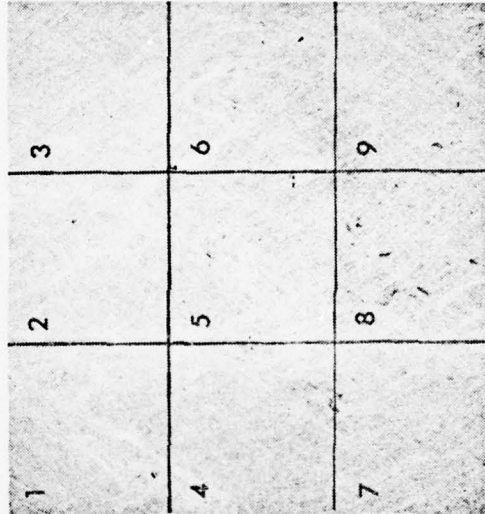

Right Front
Level E

FIGURE 4.32 A TOP VIEW OF THE NON-ENZYMATIC BROWNING REACTION IN THE FIBER GLASS AFTER EXPOSURE IN A MICROWAVE OVEN; AREA GRID LINES SUPER-IMPOSED TO SHOW INDIVIDUAL SAMPLE CELLS

were further verified by over wattage output tests for Areas #1 and #6. See Table 3.11. There was a net difference of 88 cooking watts/hour between the hot and cold spots of the oven tested.

In general, the measure used to determine electric field distribution could be useful in positioning various portioned food items in the microwave oven for heating. The center of the oven (Area #5) is generally recommended for positioning the plate while heating portioned foods. Assuming that the plate is placed in the center of the oven while heating, the proper positioning of the portioned food on the plate to attain optimal ending temperatures can be determined. The relationship of electric field distribution to heating portioned foods in the microwave oven studied can be seen in Figure 4.33 where an eight inch plate is super-imposed on the area grid means of the browning reaction. By placing a "hard to heat" item such as a pork chop on the right front section of the plate (areas 5, 6, 8 and 9) a faster heating rate would be attained in relationship to an "easy to heat" item placed on the opposite side of the plate (Areas 1, 2, 4 and 5). Thus, both items might attain an optimal ending temperature at the same time.

The method used in this research to determine electric field distribution utilized a heating time that was approximately four times longer than what is normally used for heating portioned foods. Correlation between the two different heating times as it relates to the intensity of microwave

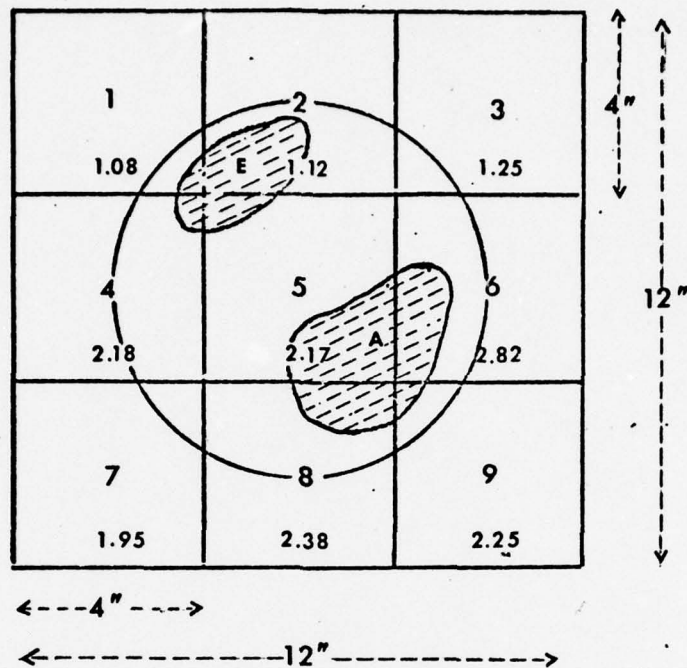

FIGURE 4.33 APPROXIMATE LOCATION IN A MICROWAVE OVEN OF AN EIGHT INCH PLATE NORMALLY USED TO HEAT PORTIONED FOODS, SUPER-IMPOSED ON THE AREA GRID MEANS OF ABSORBENCY UNITS OF THE BROWNING REACTION; HARD TO HEAT FOOD ITEM (A) AND EASY TO HEAT FOOD ITEM (E) POSITIONED IN AREAS OF HIGH AND LOW ELECTRIC FIELD INTENSITY, RESPECTIVELY

energy may be questioned; however the oven wattage tests, in which water was exposed to microwave energy for approximately the same time as recommended for portioned foods, substantiated the relative difference between the cold and hot spots of the oven tested.

CHAPTER 5

SUMMARY, CONCLUSIONS AND RECOMMENDATIONS

5.1 Summary

The purpose of this research was to develop a method for measuring electric field distribution in a microwave oven.

The dielectric loss properties of fiber glass were studied to determine its suitability as a vehicle for electric field distribution determination. To measure the dielectric loss properties of the fiber-glass, 50 ml of distilled water were heated in a microwave oven for 10 seconds in a styrofoam container. The mean Δt in degrees F of the water for six replications provided a basis for comparison when the water and dry untreated fiber glass were heated in the oven. Based on the results of the experiment the fiber glass was found to absorb no microwave energy.

Using the non-enzymatic browning reaction in a model system to measure electric field distribution, glucose and glycine were combined in a 25 per cent concentration and sprayed into the fiber glass matrix. After heating in a microwave oven for 4.5 minutes, each of five levels were divided into nine sample cells measuring 4 x 4 x 1 inches. These areas approximated the space normally occupied by portioned food items heated in a microwave oven.

Distilled water was used as a solvent to extract the browning reaction material from the fiber glass matrix. An objective measure of color formation was made using a spectrophotometer. Analysis of variance of the absorbency units for the 45 sample cells indicated that there was no significant difference among the three replications. Significant level and area differences were indicative of the uneven electric field distribution in the area of the microwave oven cavity studied. The lower levels of the oven studied had the greatest range in electric field concentration while the upper levels exhibited a more uniform but less intense energy pattern as measured by the non-enzymatic browning reaction. The areas found to be the hottest and coldest were checked for wattage output. The hot and cold spots were below the rated output of 1300 watts by 12.1 and 18.9 per cent, respectively. Photographs of the browning reaction in the fiber glass further substantiated the level and area differences of electric field distribution determined by statistical analysis.

5.2 Conclusions

The purpose of this research was to develop a procedure for measuring electric field distribution in a microwave oven. Based on the results of analyzing three replications of 45 sample cells, the procedure developed did measure the electric field distribution in a microwave oven.

Although the procedure was based on the non-enzymatic browning reaction in a model system and quantified by spectrophotometric analysis, visual evaluation of the electric field distribution was possible. The fiber glass matrix provided a three-dimensional picture of energy distribution which, though difficult to quantify visually, does provide a tangible method for oven performance evaluation without employing detailed and lengthy analysis techniques.

In comparison with other techniques of microwave oven evaluation reported in the literature, this method was unique in that the "total" electric field distribution could be measured during a single exposure to microwave energy. Previous techniques were limited to single plane evaluation and did not record possible perturbation of the electric field occurring in planes not being measured at the time of exposure. Although not attempted in this study, the method developed makes it possible to record energy distribution while heating portioned foods by simply removing a portion of the measuring media and substituting plated food items. The possible microwave perturbations caused by particular portioned foods could thus be studied.

The procedure used to divide each level into nine equal areas provided a method to assign objective values based on spectrophotometric analysis; however the actual electric field distribution pattern did not conform to the division of cells that was established. Each cell value

represented a "blend" of high and low levels of electric field intensity as measured by the browning reaction and was visually evident as shown in Figure 4.32. In this sense, visual analysis and photographic records of the browning reaction provided a more precise picture of the actual electric field distribution.

For this study, the fiber glass assemblage was heated in a microwave oven for 4.5 minutes. The heating time was established based on preliminary experiments whereby color formation and final ending weight were considered as important parameters. Because of the variable wattage output of different ovens, total exposure time to microwave energy must be adjusted in accordance with the weight of the glucose/glycine solution, the total space being measured in the oven cavity and the specific wattage output of the oven being measured.

The procedure developed for measuring microwave distribution patterns was used to record electric field distribution in two ovens in addition to the oven reported in this study. Each oven displayed standing wave patterns different from the oven studied; the procedure was consistent in recording a particular distribution pattern with a given oven based on visual analysis. The three microwave ovens tested were all of a different model and/or manufacturer. All displayed levels and areas of high and low electric field intensity as measured by the browning reaction. This tends to confirm Kumpfer's (1972) statement that the achievement of an acceptable energy pattern is usually one

of the most difficult problems facing the designer.

The implication of this study is that it can provide a tool to the manufacturer for evaluating optimal oven design to attain uniform electric field distribution within the cavity. For the user, the positioning of food items to achieve uniform heating need not be relegated to trial and error. Optimal placement of portioned foods for desired ending temperature can be determined using the procedure developed for measuring electric field distribution in the microwave oven.

5.3 Recommendations

The procedure reported in Chapter 3.2 was assumed to measure the dielectric loss properties of the fiber glass used in this study. As shown in Table 3.21 the slight mean temperature increase reported while heating the fiber glass and water when compared to the water alone was perhaps due to experimental error. To minimize this error it is recommended that the exposure time and water volume be increased.

Considerable variation in the quality of the fiber glass was experienced. Two rolls of fiber glass purchased on different occasions varied in texture despite the fact that both rolls had identical labelling. The fiber glass used during the data collection phase had a matted layer on both surfaces as compared with only one surface being matted on the fiber glass sheets used for preliminary experiments. The removal of both surfaces apparently caused a

reduced strength of the matrix and subsequent compression of the lower level sheets when impregnated with the glucose/glycine solution. Although the compression effect was not considered a factor affecting the outcome of this study, it is recommended that future studies be conducted with fiber glass that has adequate matrix strength that will minimize compression caused by the weight of the glucose/glycine solution.

Although various colors of the non-enzymatic browning reaction were transformed into absorbency units, a clear relationship of their meaning to heating foods was not established. A useful relationship could be established by developing a standard curve for the glucose/glycine solution relative to the time/temperature relationship for the browning reaction. By conventionally heating a glucose/glycine solution and periodic sampling at a given temperature, the sequential development of the browning reaction can be recorded and transformed into absorbency units using the spectrophotometer. This would provide a basis for comparison with the microwave heated test media and could be translated into an "equivalent" conventional heating time/temperature relationship.

The method developed can be used in any microwave oven to determine electric field distribution. By cutting the fiber glass to the desired size, energy distribution patterns can be determined in both large and small cavities.

Although a particular electric field distribution pattern was established in the microwave oven studied, further studies are recommended to determine the effect of uneven energy distribution on portioned food.

APPENDIX

TABLE 1 DILUTION FACTOR AND ABSORBENCY UNITS FOR THE BROWNING REACTION COLLECTED FROM 45 SAMPLE CELLS OF FIBER GLASS USED TO MEASURE ELECTRIC FIELD DISTRIBUTION IN A MICROWAVE OVEN

LEVEL AREA	ml		ml		Dil. Factor	Absorbency Units	
	1st Dilution	Solution Water	2nd Dilution	Solution Water		Direct Reading	Total Value
Replication #1							
A	1	-	-	-	1	.855	.855
	2	-	-	-	1	.516	.516
	3	2	10	-	6	.382	2.292
	4	1	16	-	17	.817	13.889
	5	1	18	-	19	.589	11.362
	6	1	22	1	46	.455	20.930
	7	1	13	-	14	.579	8.106
	8	1	20	-	21	.555	11.655
	9	1	16	-	17	.788	13.396
B	1	-	-	-	1	.297	.297
	2	-	-	-	1	.132	.132
	3	-	-	-	1	.837	.837
	4	4	18	8	4	8.25	5.750
	5	2	14	-	8	.765	6.120
	6	1	17	-	18	.645	11.610
	7	2	10	-	6	.918	5.508
	8	2	17	-	9.5	.765	7.267
	9	2	17	-	9.5	.613	5.823
C	1	-	-	-	1	.505	.505
	2	-	-	-	1	.597	.597
	3	-	-	-	1	.937	.937
	4	2	9	-	5.5	.782	4.301
	5	2	17	-	9.5	.790	7.505
	6	1	17	-	18	.762	13.616
	7	2	13	-	7.5	.573	4.297
	8	1	10	-	11	.625	6.875
	9	1	10	-	11	.585	6.435
D	1	-	-	-	1	.237	.237
	2	-	-	-	1	.185	.185
	3	-	-	-	1	.436	.436
	4	3	4	-	2.33	.364	.849
	5	3	4	-	2.33	.385	.898
	6	3	8	-	3.66	.648	2.375
	7	3	8	-	3.66	.404	1.481
	8	3	8	-	3.66	.505	1.851
	9	3	8	-	3.66	.359	1.316
E	1	-	-	-	1	.455	.455
	2	-	-	-	1	.066	.066
	3	-	-	-	1	.512	.512
	4	-	-	-	1	.858	.858
	5	-	-	-	1	.675	.675
	6	3	4	-	2.33	.584	1.363
	7	3	4	-	2.33	.745	1.738
	8	3	4	-	2.33	.500	1.166
	9	3	4	-	2.33	.540	1.259

TABLE 1 (Continued)

LEVEL	AREA	ml		ml		Dil Factor	Absorbency Units	
		1st Dilution Solution	Water	2nd Dilution Solution	Water		Direct Reading	Total Value
Replication #2								
A	1	2	5	-	-	3.5	.395	1.382
	2	2	5	-	-	3.5	.414	1.449
	3	2	10	-	-	6	.404	2.424
	4	2	20	1	1	22	.410	9.020
	5	2	20	-	-	11	.991	10.901
	6	1	30	-	-	31	.325	10.075
	7	2	14	-	-	8	.743	5.944
	8	2	20	-	-	11	.820	9.020
	9	2	20	-	-	11	.825	9.075
B	1	2	10	-	-	6	.442	2.652
	2	3	10	-	-	4.33	.310	1.343
	3	2	10	-	-	6	.461	2.766
	4	1	20	8	8	42	.478	20.076
	5	1	20	-	-	21	.545	11.445
	6	1	20	8	8	42	.509	21.378
	7	1	20	-	-	21	.283	5.943
	8	1	20	-	-	21	.512	10.752
	9	1	20	-	-	21	.381	8.001
C	1	-	-	-	-	1	.905	.905
	2	-	-	-	-	1	.686	.686
	3	-	-	-	-	1	.705	.705
	4	1	10	-	-	11	.383	4.213
	5	1	10	-	-	11	.210	2.310
	6	1	14	-	-	15	.428	6.420
	7	2	10	-	-	6	.443	2.658
	8	1	10	-	-	11	.378	4.158
	9	1	10	-	-	11	.275	3.025
D	1	5	5	-	-	2	.503	1.006
	2	-	-	-	-	1	.666	.666
	3	-	-	-	-	1	.419	.419
	4	2	10	-	-	6	.439	2.634
	5	1	10	-	-	11	.368	4.048
	6	1	10	-	-	11	.230	2.530
	7	5	5	-	-	2	.722	1.444
	8	2	14	-	-	8	.442	3.536
	9	1	10	-	-	11	.223	2.453
E	1	-	-	-	-	1	.000	.000
	2	-	-	-	-	1	.000	.000
	3	-	-	-	-	1	.000	.000
	4	-	-	-	-	1	.213	.213
	5	-	-	-	-	1	.169	.169
	6	-	-	-	-	1	.656	.656
	7	-	-	-	-	1	.295	.295
	8	-	-	-	-	1	.715	.715
	9	-	-	-	-	1	.385	.385

TABLE 1 (Continued)

LEVEL AREA	m ^l		m ^l		Dil Factor	Absorbency Units		
	1st Dilution	Solution Water	2nd Dilution	Solution Water		Direct Reading	Total Value	
Replication #3								
A	1	6	10	-	-	2.66	.413	1.101
	2	2	10	-	-	6	.416	2.496
	3	2	10	-	-	6	.344	2.064
	4	2	20	-	-	11	.470	5.170
	5	1	10	-	-	11	.823	9.053
	6	1	20	-	-	21	.786	16.504
	7	1	10	-	-	11	.437	4.807
	8	1	20	-	-	21	.432	9.072
	9	1	10	-	-	11	.722	7.942
B	1	-	-	-	-	1	.142	.142
	2	-	-	-	-	1	.185	.185
	3	-	-	-	-	1	.919	.919
	4	1	10	-	-	11	.492	5.412
	5	3	15	-	-	6	.646	3.876
	6	1	15	-	-	16	.734	11.744
	7	3	10	-	-	4.33	.858	3.717
	8	2	20	-	-	11	.678	7.458
	9	1	10	-	-	11	.591	6.501
C	1	-	-	-	-	1	.515	.515
	2	3	5	-	-	2.66	.477	1.272
	3	-	-	-	-	1	.766	.766
	4	3	10	-	-	4.33	.535	2.318
	5	2	10	-	-	6	.553	3.318
	6	2	20	-	-	11	.655	7.205
	7	2	10	-	-	6	.493	2.958
	8	2	15	-	-	8.5	.680	5.780
	9	2	10	-	-	6	.883	5.298
D	1	-	-	-	-	1	.844	.844
	2	5	15	-	-	4	.635	2.540
	3	5	10	-	-	3	.579	1.737
	4	5	10	-	-	3	.575	1.725
	5	2	5	-	-	3.5	.873	3.055
	6	4	15	-	-	4.75	.846	4.018
	7	4	15	-	-	4.75	.826	3.923
	8	4	25	-	-	7.25	.835	6.053
	9	2	10 ²	-	-	6	.742	4.452
E	1	-	-	-	-	1	.108	.108
	2	-	-	-	-	1	.835	.835
	3	-	-	-	-	1	.839	.839
	4	3	5	-	-	2.66	.722	1.925
	5	-	-	-	-	1	.414	.414
	6	5	15	-	-	4	.403	1.612
	7	5	10	-	-	3	.443	1.329
	8	5	5	-	-	2	.533	1.066
	9	5	15	-	-	4	.400	1.600

TABLE 2 RANGE, MEAN AND VARIANCE OF ABSORBENCY UNITS FOR THE BROWNING REACTION COLLECTED FROM 45 SAMPLE CELLS OF FIBER GLASS USED TO MEASURE ELECTRIC FIELD DISTRIBUTION IN A MICROWAVE OVEN

LEVEL	AREA	RANGE		MEAN		VARIANCE	
		Original n=3	Transformed $\sqrt{X + .5}$	Original	Transformed $\sqrt{X + .5}$	Original	Transformed $\sqrt{X + .5}$
A	1	.855-1.382	1.164-1.372	1.113	1.267	.0695	.0107
	2	.516-2.496	1.008-1.731	1.487	1.378	.9811	.1308
	3	2.064-2.424	1.601-1.738	2.260	1.661	.0331	.0030
	4	5.170-13.889	2.381-3.798	9.360	3.087	19.0917	.4985
	5	9.053-11.362	3.091-3.444	10.438	3.304	1.4931	.0351
	6	10.075-20.930	3.252-4.629	15.837	4.002	29.7934	.4854
	7	4.807-8.106	2.304-2.934	6.285	2.592	2.8080	.1013
	8	9.020-11.655	3.085-3.486	9.916	3.222	2.2696	.0524
	9	7.942-13.396	2.905-3.728	10.138	3.243	8.2834	.1854
B	1	.142-2.652	.801-1.775	1.033	1.156	1.9783	.2893
	2	.132-1.343	.795-1.357	.553	.993	.4683	.0997
	3	.837-2.766	1.156-1.807	1.507	1.385	1.1898	.1340
	4	5.412-20.076	2.431-4.536	10.413	3.156	70.0635	1.4299
	5	3.876-11.445	2.092-3.456	7.147	2.707	15.1134	.4787
	6	11.610-21.378	3.480-4.677	14.901	3.884	31.4695	.4720
	7	3.717-5.943	2.053-2.538	5.056	2.348	1.3919	.0067
	8	7.267-10.752	2.787-3.354	8.492	2.987	3.8386	.1012
	9	5.823-8.001	2.515-2.916	6.775	2.693	1.2422	.0418
C	1	.505-.905	1.002-1.185	.642	1.065	.0520	.0108
	2	.597-1.272	1.047-1.331	.852	1.156	.1344	.0234
	3	.705-.937	1.097-1.198	.803	1.141	.0144	.0027
	4	2.318-4.301	1.678-2.191	3.611	2.014	1.2551	.0842
	5	2.310-7.505	1.676-2.829	4.378	2.153	7.5891	.3621
	6	6.420-13.716	2.631-3.770	9.114	3.059	16.0401	.3849
	7	2.658-4.297	1.777-2.190	3.304	1.942	.7615	.0478
	8	4.158-6.875	2.158-2.715	5.604	2.460	1.8686	.0792
	9	3.025-6.435	1.877-2.633	4.919	2.306	3.0145	.1506

Table 2 (Continued)

LEVEL	AREA	RANGE		MEAN		VARIANCE	
		Original n=3	Transformed $\sqrt{X + .5}$	Original	Transformed $\sqrt{X + .5}$	Original	Transformed $\sqrt{X + .5}$
D	1	.237-1.006	.858-1.227	.696	1.082	.1643	.0385
	2	.185-2.540	.827-1.743	1.130	1.217	1.5482	.2238
	3	.419-1.737	.959-1.500	.864	1.141	.5716	.0945
	4	.849-2.634	1.161-1.770	1.736	1.474	.7966	.0928
	5	.898-4.048	1.182-2.132	2.667	1.733	2.5935	.2430
	6	2.375-4.018	1.700-2.125	2.974	1.854	.8229	.0558
	7	1.444-3.923	1.394-2.103	2.283	1.635	2.0183	.1644
	8	1.851-6.053	1.533-2.559	3.813	2.034	4.4718	.2639
	9	1.316-4.452	1.348-2.225	2.740	1.764	2.5205	.1941
E	1	.000-.455	.707-.977	.188	.821	.0565	.0195
	2	.000-.835	.707-1.155	.300	.872	.2154	.0609
	3	.000-.839	.707-1.157	.450	.957	.1788	.0524
	4	.213-1.925	.844-1.557	.998	1.189	.7475	.1274
	5	.169-.675	.818-1.084	.419	.952	.0640	.0177
	6	.656-1.612	1.075-1.453	1.210	1.298	.2459	.3910
	7	.255-1.738	.869-1.496	1.120	1.247	.5531	.0996
	8	.715-1.166	1.102-1.291	.982	1.215	.0561	.0098
	9	.385-1.600	.941-1.449	1.081	1.239	.3927	.0703

TABLE 3 ESTIMATE OF TREATMENT MEANS OF ABSORBENCY UNITS FOR THE BROWNING REACTION FROM NINE AREAS OF FIBER GLASS USED TO MEASURE ELECTRIC FIELD DISTRIBUTION IN A MICROWAVE OVEN

AREA	MEAN ABSORBENCY UNITS*	MEAN ABSORBENCY UNITS** $\sqrt{X + .5}$
1	0.73406	1.0783
2	0.86450	1.1232
3	1.17670	1.2567
4	5.22336	2.1839
5	5.00990	2.1700
6	8.80704	2.8192
7	4.90980	1.9526
8	5.76156	2.3836
9	5.13058	2.2486

* With S.E. $(\hat{y}_i) = 1.001$

** With S.E. $(\hat{y}_i) = 0.1794$

TABLE 4 ESTIMATE OF TREATMENT MEANS OF ABSORBENCY UNITS
FOR THE BROWNING REACTION FOR FIVE LEVELS OF FIBER
GLASS USED TO MEASURE ELECTRIC FIELD DISTRIBUTION
IN A MICROWAVE OVEN

LEVEL	MEAN ABSORBENCY UNITS*	MEAN ABSORBENCY UNITS** $\sqrt{X + .5}$
A	7.4254	2.6393
B	6.2119	2.3676
C	3.6917	1.9217
D	2.1003	1.5482
E	0.7496	1.0877

* With S.E. (\hat{y}_i) = 1.01

** With S.E. (\hat{y}_i) = 0.1995

REFERENCES

- Bengtsson, N. E., and E. Lycke. 1969. Experiments with a heat camera for recording temperature distribution in foods during microwave heating. *J. Microwave Power* 4(2):48-53.
- Burr, I. W., and L. A. Foster. 1972. A test for equality of variance. Mimeograph series 282, Department of Statistics, Purdue University. 1 p.
- Daly, P. 1973. Packaging and the microwave oven, pp.4-5. In Current developments in consumer and commercial microwave ovens. Los Angeles Home Economics in Business, Los Angeles.
- Decareau, R. V. 1972. Microwave heating control techniques. *Microwave Energy Appl. Newsl.* 5(5):3-7.
- Giles, P. G., E. E. Moore, and L. Bounds. 1970. Investigation of heat penetration of food samples at various frequencies. *J. Microwave Power* 5(1):40-43.
- Goldblith, S. A. 1972. Radio-frequency energy the theory of its interaction with foodstuffs and possible applications in food processing. *Microwave Energy Appl. Newsl.* 5(6):3-11.
- Hodge, J. E. 1953. Chemistry of browning reaction in model systems. *J. of Agr. and Food Chem.* 1:928-943.
- Hodgman (ed). 1960-1961. Handbook of chemistry and physics, 42nd ed. The Chemical Rubber Publishing Company, Cleveland, Ohio. 3237 p.
- Kumpfer, B. D. 1972. A simple system of microwave pattern measurement. *Microwave Energy Appl. Newsl.* 5(4):10-16.
- Labuza, T. P. 1972. Nutrient losses during drying and storage of dehydrated foods. *Critical Reviews in Food Technology* 3:217-240.

- Litton Systems Inc. 1972. Litton microwave ovens hospital patient feeding systems. Litton Industries, Atherton Division, Minneapolis, Minnesota. 3.1-4.4.
- McConnell, C. R. 1973. The impact of microwaves on the future of the food industry: domestic and commercial microwave ovens. *J. Microwave Power* 8(2):123-127.
- Mendenhall, W. 1967. Introduction to probability and statistics. Dusbury Press. Belmont, CA. 466 p.
- Napleton, L. 1971. A guide to microwave catering. Northwood Publications, Ltd. London, W.C. 1. 107 p.
- Peterson, A., and R. A. Foerstner. 1971. Evaluation of microwave oven cooking performance. *Microwave Energy Appl. Newsl.* 4(1):3-8.
- Steel, R., and J. H. Torrie. 1960. Principles and procedures of statistics. McGraw-Hill. New York. 481 p.
- Scott, G. A. 1973. The development of a microwave oven performance standard - problems and possibilities. Paper 5. B. 1. Presented at International Microwave Power Institute symposium - Sept. The International Microwave Power Institute. Edmonton, Alberta, Canada.
- Stuckly, S. S., and M. A. Hamid. 1972. Physical parameters in microwave heating process. *J. Microwave Power* 7(2): 117-137.
- Torrie, J. H. 1963. The use of statistics in the summarization and presentation of scientific articles in foods and nutrition, pp. 167-169. *In Proc. conf. on college teaching of foods and nutrition.* University of Wisconsin, Madison.
- Tracy, W. M. 1974. Determining the electric field distribution in a 1250 watt microwave oven and its effect on food during heating. Unpublish M. S. Thesis. University of Wisconsin, Madison. 112 p.
- Van Zante, H. J. 1966. Determination of cooking power distribution in electronic ranges. *J. Home Econ.* 58(4):292-295.

- Van Zante, H. J. 1973. The microwave oven. Houghton Mifflin Company, Boston. 184 p.
- Watanabe, M., M. Suzuki, I. Kikuchi, Y. Fukui, and K. Hirakawa. 1974. A means of detecting temperature of food in microwave electromagnetic field, pp. B3-3/1-B3-3/3. In Proceedings of microwave power symposium-1974. The International Microwave Power Institute. Edmonton, Alberta, Canada.
- Weizeorick, J. T. 1972. Systems approach to consumer microwave cooking. J. Microwave Power 7(1):57-61.
- Weizeorick, J. T. 1974. Association of Home Appliance Manufacturers, Chicago. Personal communication.
- Wilhelm, M. S., and L. D. Satterlee. 1971. A 3-dimensional method for mapping microwave ovens. Microwave Energy Appl. Newsl. 4(5):3-5.