

AD-A052 066

WOODS HOLE OCEANOGRAPHIC INSTITUTION MASS  
AN ACOUSTIC SENSOR OF VELOCITY FOR BENTHIC BOUNDARY LAYER STUDI--ETC(U)  
APR 78 A J WILLIAMS, J S TOCHKO  
WHOI-78-4

F/G 8/3

N00014-74-C-0262

NL

UNCLASSIFIED

| OF |

AD  
A052 066



END  
DATE  
FILMED  
5-78  
DDC

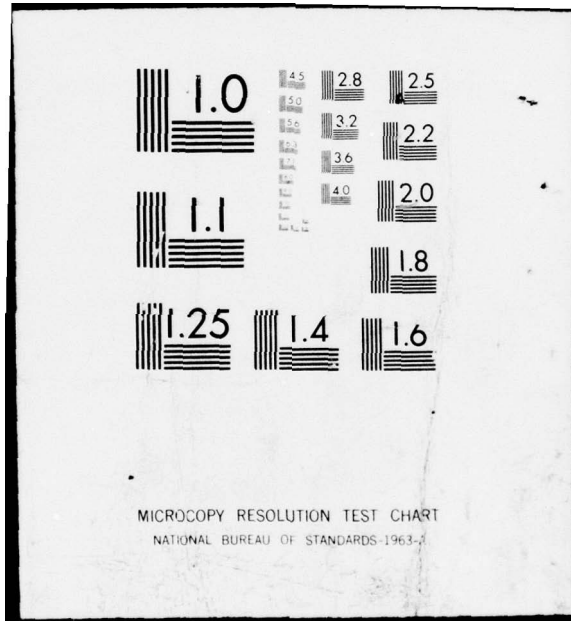

MICROCOPY RESOLUTION TEST CHART  
NATIONAL BUREAU OF STANDARDS-1963-A

AD NO.   
 DDC FILE COPY

AD A 052066

Woods Hole  
Oceanographic  
Institution



AN ACOUSTIC SENSOR OF VELOCITY FOR  
BENTHIC BOUNDARY LAYER STUDIES

by

Albert J. Williams 3rd  
and  
John S. Tothko

April 1978

TECHNICAL REPORT

SECURITY CLASSIFICATION OF THIS PAGE (When Data Entered)

REPORT DOCUMENTATION PAGE		READ INSTRUCTIONS BEFORE COMPLETING FORM
1 REPORT NUMBER	2 GOVT ACCESSION NO.	3 RECIPIENT'S CATALOG NUMBER
(14) WHOI-78-4, WHOI-CONTRIB-3843		
4 TITLE (and Subtitle)	5 TYPE OF REPORT & PERIOD COVERED	
(6) AN ACOUSTIC SENSOR OF VELOCITY FOR BENTHIC BOUNDARY LAYER STUDIES	(9) Technical rept.	
7. AUTHOR(s)	6. PERFORMING ORG. REPORT NUMBER	
(14) Albert J. Williams, III John S. Tochko	WHOI CON. NO. 3843	
	8. CONTRACT OR GRANT NUMBER(s)	
	(15) N00014-74-C-0262	
9 PERFORMING ORGANIZATION NAME AND ADDRESS	10. PROGRAM ELEMENT, PROJECT, TASK AREA & WORK UNIT NUMBERS	
Woods Hole Oceanographic Institution Woods Hole, MA 02543	NR 083-004	
11 CONTROLLING OFFICE NAME AND ADDRESS	12. REPORT DATE	
NORDA National Space Technology Laboratory Bay St. Louis, MS 39529	(11) Apr 1978	
14 MONITORING AGENCY NAME & ADDRESS (if different from Controlling Office)	13. NUMBER OF PAGES	
	15. SECURITY CLASS. (of this report)	
	Unclassified	
	15a. DECLASSIFICATION/DOWNGRADING SCHEDULE	
16. DISTRIBUTION STATEMENT (of this Report)		
Approved for public release; distribution unlimited. (12) 19p.		
17. DISTRIBUTION STATEMENT (of the abstract entered in Block 20, if different from Report)		
18. SUPPLEMENTARY NOTES		
Reprinted from the "Proceedings of the 8th International Colloquium on Ocean Hydrodynamics". (84)		
19. KEY WORDS (Continue on reverse side if necessary and identify by block number)		
1. Velocimeter 2. Boundary layer flow 3. Reynolds stress		
20. ABSTRACT (Continue on reverse side if necessary and identify by block number)		
<p>→ The techniques of flow measurement which have been successful in laboratory studies of boundary layer turbulence are difficult to use in the ocean; and the current meters generally used in the ocean are not suited to measuring bottom boundary layer flow. A suitable sensor for bottom turbulence measurements should measure vector components, respond linearly to these components, maintain an accurate zero point, disturb the flow negligibly or in a well predicted way, and sense a small enough volume to represent (Cont. on back)</p>		

DD FORM 1473

1 JAN 73

EDITION OF 1 NOV 65 IS OBSOLETE

S/N 0102-014-6601

UNCLASSIFIED

4/78

SECURITY CLASSIFICATION OF THIS PAGE (When Data Entered)

381 000

EB  
A

the important scales of the flow. We have constructed an acoustic travel time sensor in a configuration that will allow vector components of the flow to be measured with sufficient accuracy to compute Reynolds stress at a point 50 cm above the bottom. This sensor responds linearly to horizontal and vertical flows in flume tests. When the flow is neither horizontal nor vertical, the wake from one acoustic transducer may interfere with the measurement along one sensing path but there is sufficient redundancy in the determination to reject this path and still resolve the vector velocity. An instrument using four of these sensors is being designed to measure Reynolds stress in the lower six meters of the ocean.



WHOI-78-4

AN ACOUSTIC SENSOR OF VELOCITY FOR  
BENTHIC BOUNDARY LAYER STUDIES

by

Albert J. Williams 3rd  
and  
John S. Tochko

WOODS HOLE OCEANOGRAPHIC INSTITUTION  
Woods Hole, Massachusetts 02543

April 1978

TECHNICAL REPORT

*Prepared for the Office of Naval Research  
under Contract N00014-74-C-0262; NR 083-004.*

*Reproduction in whole or in part is permitted  
for any purpose of the United States Government.  
In citing this report in a bibliography, the  
reference given should be to the "Proceedings  
of the 8th International Colloquium on Ocean  
Hydrodynamics".*

*Approved for public release; distribution  
unlimited.*

Approved for Distribution: Earl E. Hays, Chairman  
Department of Ocean Engineering

ADP	
NTIS	White Section <input checked="" type="checkbox"/>
DDC	Soft Section <input type="checkbox"/>
USNA	<input type="checkbox"/>
JUST	<input type="checkbox"/>
BY...	
DISP...	REPRODUCIBILITY CODES
RE...	SPECIAL
A	

## AN ACOUSTIC SENSOR OF VELOCITY FOR BENTHIC BOUNDARY LAYER STUDIES\*

Albert J. Williams 3rd and John S. Tochko  
Woods Hole Oceanographic Institution

## ABSTRACT

The techniques of flow measurement which have been successful in laboratory studies of boundary layer turbulence are difficult to use in the ocean; and the current meters generally used in the ocean are not suited to measuring bottom boundary layer flow. A suitable sensor for bottom turbulence measurements should measure vector components, respond linearly to these components, maintain an accurate zero point, disturb the flow negligibly or in a well predicted way, and sense a small enough volume to represent the important scales of the flow. We have constructed an acoustic travel time sensor in a configuration that will allow vector components of the flow to be measured with sufficient accuracy to compute Reynolds stress at a point 50 cm above the bottom. This sensor responds linearly to horizontal and vertical flows in flume tests. When the flow is neither horizontal nor vertical, the wake from one acoustic transducer may interfere with the measurement along one sensing path but there is sufficient redundancy in the determination to reject this path and still resolve the vector velocity. An instrument using four of these sensors is being designed to measure Reynolds stress in the lower six meters of the ocean.

Velocity Sensor Requirements for Ocean Benthic Boundary Layer (BBL) Studies

The goal of BBL measurements is an understanding of interactions of the flow with the benthic boundary; the flow being characterized by a time series of relevant flow parameters at enough distances from the sea floor to infer a profile. The time series must be long enough to sample the important processes in the flow-boundary interactions, presumably "bursting" being one of the most important ones, and the samples must be frequent enough to prevent aliasing of high frequency components of the flow. Furthermore, it is desirable that the series be long enough that many independent samples of the lowest frequency of interest in the flow might

---

\*Woods Hole Oceanographic Institution Contribution Number 3843.

be obtained and the series might well be repeated at intervals over several days to detect the flow variability with driving forces of longer periods such as tides, mid-ocean eddies, and changes of internal sea state.

To prevent aliasing of high frequency components of the flow, the velocity must be sampled at twice the maximum frequency that can be sensed by the sensor. Converting the maximum frequency to a wavenumber by dividing by the expected advection velocity of the flow gives the maximum wavenumber which can be sensed without aliasing. It is necessary to make a spatial average of the flow velocity to prevent the sensing of higher wavenumber components than desired, and the size of the averaging volume or averaging length cannot be reduced without increasing the sampling rate or risking aliasing. This minimum volume or maximum wavenumber sets the limit on the finest scale of turbulence which can be probed. Assuming the scale of the most energetic eddy in a boundary layer flow is the order of the distance from the wall, the sensor should be placed several times its averaging length from the sea floor to sample the energetic portion of the turbulence spectrum. Thus the first requirement of a velocity sensor is that it be small enough to sample the scales of turbulence of interest and that the sensor be sampled often enough to avoid aliasing considering its averaging length and the expected advection velocity.

The two most important flow parameters which should be measured are the mean velocity and the Reynolds stress. If the Reynolds stress is to be calculated from instantaneous vector velocities, the requirements imposed on the velocity sensor by this measurement are more demanding than those of measuring the mean velocity. This will be assumed throughout.

Tilt of the measurement coordinates with respect to the actual mean flow direction causes a false contribution to the Reynolds stress from fluctuations in the component of current in the mean flow direction. A digression is necessary to clarify the terms used for the coordinates. The velocity components  $u$ ,  $v$ , and  $w$  are the horizontal downstream, horizontal cross-stream and vertical velocity components respectively in a flow along a horizontal boundary. If the boundary is not horizontal, the terms "horizontal" and "vertical" are misleading but could be replaced by the terms "parallel to the boundary" and "normal to the boundary". The latter terms retain the notion that the Reynolds stress is a measure of momentum exchange between the flow parallel to the boundary and that boundary. However, if the boundary is not even flat, these terms may be inadequate and one must go back to defining the downstream direction,  $x$ , as the direction that produces zero mean in the velocity along the two orthogonal



directions y and z, i.e.  $\bar{v} = \bar{w} = 0$ . This defines x but not y or z. If the mean flow changes direction, the old and new mean flow directions define the xy plane and the z direction is the normal to this plane. Operationally, this is a convenient definition of the measurement coordinates. To summarize: z is the direction along which the average velocity,  $\bar{w}$ , is zero for any direction of mean flow; y is the direction perpendicular to z along which the average velocity,  $\bar{v}$ , is zero; and x is the direction perpendicular to y and z along which the mean flow,  $\bar{u}$ , is measured. Errors in tilt are sufficiently serious that one should verify that the mean velocity in the direction assumed to be z is zero. If it is not, an instrumental or coordinate rotation should be performed to achieve this result.\*

Zero point uncertainty in the z axis is indistinguishable from a tilt error and thus prevents verification of the alignment and interferes with rotating the coordinates to remove tilt. The zero point error should not exceed the allowed deviation from zero of the mean of the w component of velocity. A zero offset in w of 1% of the mean velocity is equivalent to a tilt error of  $1/2^\circ$  and is probably the largest error acceptable.

Leakage of u signal into the w channel contributes an error directly to the calculated Reynolds stress. Three sources of leakage are possible: non-orthogonality of the channels, flow disturbance by the sensor, and electronic cross-talk in the sampling circuitry. Geometric controls may not necessarily ensure the orthogonality of the channels and this should be checked in a tow tank or flume by rotating the sensor  $90^\circ$  and verifying the null in the u channel. This test will not detect flow disturbance by the sensor as the flow in use will not be in these orthogonal directions. The best check on flow disturbance probably remains checking of cosine response for each vector channel. Electronic cross-talk is evidenced as a signal appearing in a channel with a dummy source present in place of the

---

\*The Reynolds stress is  $\overline{\rho u'v'}$ . The quantities  $\overline{\rho u'v'}$  and  $\overline{\rho v'w'}$  can also be computed. They would represent momentum transport that could not be extracted from a mean flow that was homogeneous in the y direction and in the x direction and thus they should be small in practice. This suggests an alternate way to define the coordinates. The y axis is chosen so that the covariance of the flow along that axis with the flow along any axis perpendicular to y is minimum. Then z is chosen perpendicular to y so that  $\bar{w} = 0$ . Finally x is chosen perpendicular to y and z.

normal sensor while another channel is normally connected and measuring flow.

Non-linearity is unacceptable in measurements used in calculating Reynolds stress and for this reason we believe only inherently linear devices are suitable for deep sea Reynolds stress sensors. Sensitivity requirements are high for low velocity flows, an approximate limit being 1% of the mean flow. Failure of the  $w$  sensor to detect small flow components will seriously underestimate the stress.

#### Classes of Sensors - Advantages and Limitations

Two classes of sensors deserve consideration (and indeed are suitable) for BBL studies by virtue of their inherently linear response and minimized interference with the measured flow. The first class is scattering sensors such as acoustic doppler and laser doppler velocimeters. The second class is volume averaging sensors such as electromagnetic and acoustic travel time velocimeters.

Scattering sensors actually measure the velocity of particles suspended in the fluid. Though these may not have the same velocity as the fluid, in open ocean water the majority of the scatterers are very small and the difference between their velocity and the fluid's velocity can usually be neglected. The exception is when the settling velocity of the particles is more than a small fraction, say 1%, of the measured vertical component.

The advantages of scattering sensors are great, the principle ones being an accurate zero point; a sensed volume that is remote from structures; reduced cross-talk; and in the case of the laser doppler velocimeter, a very small sampling volume. The fact that the signal is in the form of a frequency shift is convenient for digital sampling while the dependence of sensitivity on geometry alone makes flume calibration unnecessary.

The chief disadvantage of the scattering sensors is signal dropout due to the intermittent presence of particles in the volume hence complexity of the signal processing necessary to overcome the dropout problem. A second disadvantage is a loss of direction sense without an added frequency shifter, an expensive complexity in laser doppler velocimeters and so far unexplored option in acoustic doppler velocimeters. A third disadvantage, that the scattering is weak and requires high power levels, is probably not so serious for most BBL studies which can have brief deployments. Because the scattering volume is very small, possibly much smaller than the smallest scale of interest, the rapid sampling necessary to avoid aliasing will require excessive data storage capacity unless on-line processing is performed.

This adds additional complexity. However, for the most demanding applications, such as very near the bottom or very slow flows, laser doppler or acoustic doppler velocimeters are probably necessary. Laser doppler velocimeters are about 100 times as sensitive as acoustic doppler velocimeters and can form much smaller scattering volumes. Thus these will probably become the standard against which other sensors are compared.

One of the advantages of volume averaging sensors is the simple sampling which is allowed when the sampling volume corresponds to the smallest length scale of interest in the flow. This volume in the EM sensor is related to the volume over which the field is solenoidal or a length scale approximately the diameter of the field coil. Unfortunately, the non-uniformities in flow in regions outside the solenoidal field contribute to the measurement but in a complicated way. Ducted EM sensors avoid the complicated volume average but suffer a reduced range over which a cosine response applies. Still, under many conditions, the measurements of EM sensors appear to represent the flow averaged over the length scale of the sensor diameter. Acoustic travel time sensors average the flow over the acoustic path between the transducers. Except when the wake of one transducer disturbs the path, this average is a simple one.

An important advantage of the EM and acoustic sensors is the relative availability of the technology. Several generations of each have been made and experience has been accumulated with the techniques.

The volume averaging techniques have a linear response to the velocity component along a single axis but they do not have perfect zero points. Their sensitivities may differ from those which are calculated from physical dimensions and electronic component values so they must be calibrated in a tow tank. However, direction sense is not a problem as the signal changes sign when the flow reverses.

If care is taken with the design, the flow that is sensed is little disturbed by the physical structure of the sensors. This helps reduce cross-talk as well as minimizing disturbance to the natural flow.

#### Acoustic Travel Time Sensor

As we have the greatest experience with the acoustic travel time sensor, we are exploiting that technique for BBL studies. Our experience has been with a two-axis free-fall velocity shear meter designed by Trygve Gytre (Gytre, 1975) at Christian Michelson Institute, Bergen. The analog signals were low passed at 0.2 Hz and sampled at 5 Hz. The acoustic path between transducers was 15 cm. Two horizontal paths at right angles were

used which operated in undisturbed water due to the vertical sinking of the instrument. Figure 1 shows the instrument, SCIMP (Williams, 1974), with the acoustic shearmeter mounted vertically, its transducers at the end of the tetrapod projecting below the short vertical cylinder which houses the electronics. SCIMP was equipped with a recording CTD as well as the shearmeter to measure microstructure associated with velocity shear.

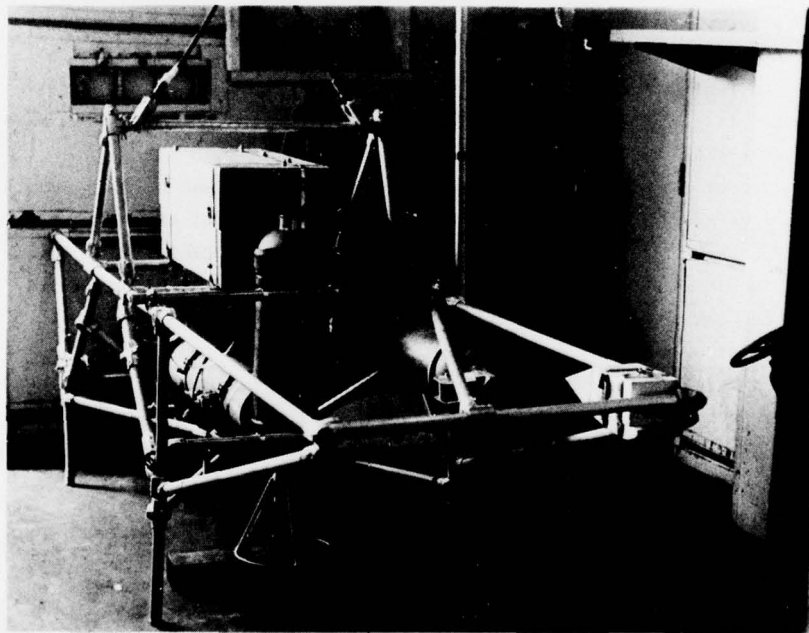

FIGURE 1: Free-fall instrument, SCIMP, containing acoustic velocity sensor as a shearmeter.



Figure 2 shows one such correlation as an example, principally, of the performance of the acoustic travel time sensor. A shear sheet located at the density interface is recorded as a sharp increase of 2 cm/sec for the time during which the velocity sensor is in the lower layer but the center of drag of the instrument still in the upper layer. The velocity returns to zero as the center of drag (50 cm above the velocity sensor) enters the lower layer. Velocity structure is also apparent in the layers on either side of the interface.

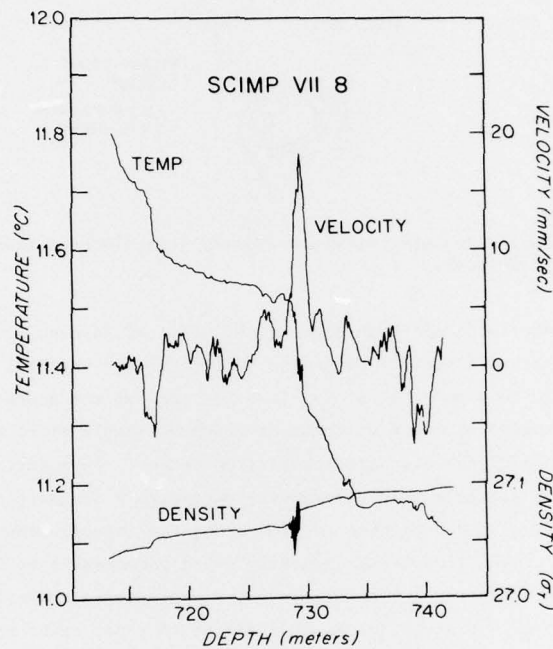

FIGURE 2: Profile of temperature, density, and horizontal velocity difference over 50 cm vertical separation.

The air backed piezoelectric crystal transducers used in the shear-meter were satisfactory to 2000 M depth but for deep ocean work we prefer pressure compensated transducers. Figure 3 shows the epoxy encapsulated crystal we now use which performs well acoustically and is not depth limited.

The geometry of the sensor head used in the shearmeter would disturb the flow in a stationary mount so the geometry illustrated in Figure 4 was devised which includes four acoustic paths and senses an undisturbed flow



if the flow is approximately horizontal or vertical. Four paths provide sufficient redundancy for a vector velocity measurement that one can be discarded if necessary. If the flow is neither horizontal nor vertical, the wake of one transducer may lie along or near one acoustic path. This path will then be discarded in determining the velocity vector. The wake may cross another path but cannot lie along or near it for any significant distance so will not disturb it to any great extent.

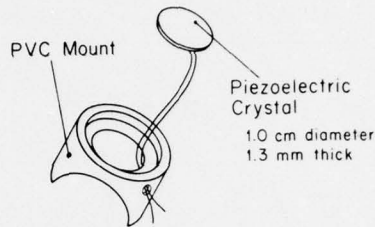

FIGURE 3: Epoxy-insulated pressure-exposed piezoelectric acoustic transducer.

Tow tank tests have been made on the model of Figure 5 and have verified the expected cosine response for horizontal and vertical flows and for diagonal flows up to about  $20^\circ$  from the axis of the acoustic path.

A discussion of the electronic arrangement should start with the general principle of the acoustic travel time sensor. As illustrated in Figure 6, two piezoelectric transducers separated a distance  $d$  are excited simultaneously. The component of flow along the intertransducer axis decreases the travel time of the acoustic pulse propagating with the current and increases the travel time of the pulse propagating against the current. The difference in travel time is  $\Delta t = 2dv/c^2$  to first order where  $c \approx 1500$  m/s is the speed of sound in the medium. Refraction due to current shear near the transducers does not effect this result directly because the path, though bent, is the same for each propagation direction and the time difference is a line integral between the transducers. An indirect effect may occur, however, through amplitude reduction.

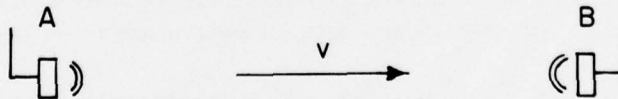

FIGURE 6: Fluid velocity component,  $v$ , along path between transducers A and B separated by distance  $d$  retards one pulse and advances the other.

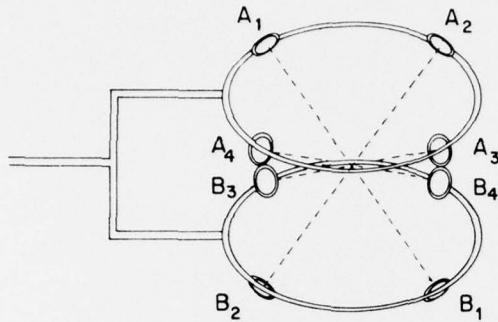

FIGURE 4: Acoustic sensor with four diagonal sensing paths.

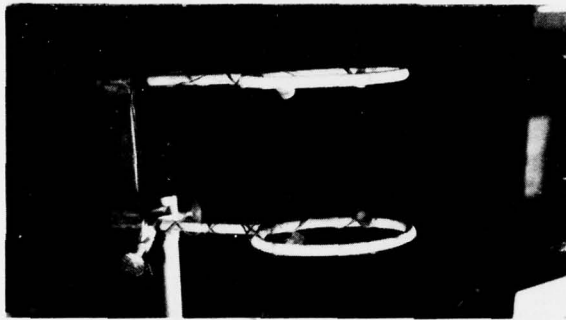

FIGURE 5: Two-path model (used in tow tests).

The pulses are generated by applying a high voltage transient to the crystals which changes their thickness and produces a compressional wave in the fluid. It is difficult to deliver enough energy to the crystal instantaneously to achieve a measurable acoustic pulse so in practice the crystal forms the capacitance of a tuned circuit, the tuned circuit building up amplitude during the first quarter cycle of its resonant period and producing a much higher voltage transient on the second quarter cycle than can be obtained instantaneously. This is the pulse that is actually used. It is, however, delayed by one-half cycle from the trigger pulse. Similarly, the received pulse excites the tuned circuit so that the second quarter cycle has a greater amplitude than the first and the comparator is set to trigger on this edge. Thus, there are two delays due to the periods

of two tuned circuits added to the travel times. The transmitting circuit adds elements not present in the receiving circuit so reciprocity does not quite hold and the differences in transmitting periods and in receiving periods produce a zero point error. Careful tuning of the inductors to the crystals can reduce this error. Temperature and pressure terms in the resonance must be similarly matched.

The received signals are detected by a pair of comparators. These make a TTL level transition a short but fixed time after the voltage from the crystal exceeds a threshold which is set to reject noise and the weak precursor pulse. The fixed delay is not the same for the two comparators and this introduces a second potential zero point error. This can be removed by interchanging the crystals between the two comparators in the scheme illustrated in Figure 7.

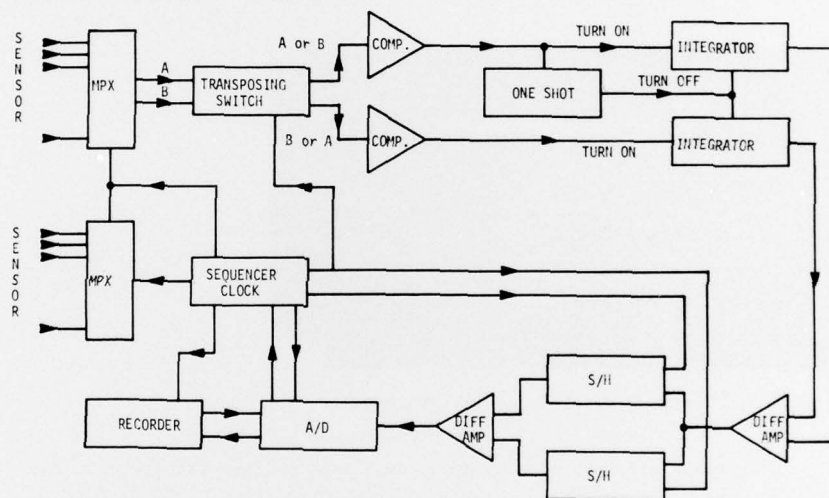

FIGURE 7: Block diagram of acoustic velocity sensor with transducer transposition for zero drift correction.

The difference in detection times is the measure of velocity. The transition of the lower comparator may occur before or after the transition of the upper comparator so a one-shot timer is triggered by the upper comparator to add a delay somewhat longer than the greatest expected time difference. Constant current ramp integrators are started by each comparator and stopped by the one-shot timer. Variations in the interval of the one-shot timer do not effect the measurement directly since they simply extend both ramps by the same amount. However, non-linearities in the ramp or

differences in ramp shape between the two integrators can produce a zero point error with one-shot timing variations. Again this can be removed by interchanging the transducers between the comparators. The only error which remains is the second order error due to jitter in the one-shot interval and this will appear as noise.

Two cycles of transmission are required for the measurement. The first cycle is performed with transducer A connected to the upper comparator and transducer B connected to the lower comparator. The sequencer triggers the transmit pulse and the received pulses are detected by the comparators. Gating (not shown) prevents premature detection and suppresses detection of the echoes of the first pulse. The integrators charge and are differenced in an operational amplifier, the output being stored in one sample and hold circuit. Then the transducers are interchanged and B connected to the upper comparator and A connected to the lower comparator. The sequencer triggers another transmit pulse and the measurement is made again, the result being stored in the other sample and hold circuit. The two sample and hold circuits are differenced and the output of the difference amplifier is digitized and recorded. Any errors introduced in the electronics between the comparators and the first difference amplifier which have remained the same for the two cycles are nulled while the time difference signals from the transducers are doubled.

In the four path sensor described before, the transducer pairs will be serviced sequentially, transducers 3 and 4 replacing 1 and 2 as the A and B channels, etc. A cycle requires 2 ms for the echoes to die and a recording of a sample takes 15 ms, thus there is ample time to obtain the velocity along the first path, switch to the second pair of transducers, and so on, recording the four velocity components in 60 ms. In fact, four separate four-path sensors can be multiplexed to a single receiver and recorded in 240 ms.

Electronic cross-talk between the received signals is a problem as the risetimes are short and large currents are needed to charge even small capacitances. The comparators are voltage sensing devices so induced voltages or common ground voltages present on the signal leads change the detection time. If two paths are sampled simultaneously, velocity components on one path will change the arrival times of the signals which then cross-talk into the other path signals to cause an apparent change in arrival time on that channel. Sequentially connecting only one pair of transducers at a time in a multiplexer removes this error.



Cross-talk between channels A and B still occurs and is difficult to detect, generally causing a lower sensitivity than calculated; in our shear-meter the decrease in sensitivity amounted to 15%. A carefully laid out prototype recently tested was much improved. The concern with cross-talk between channels A and B is not so much that this introduces an error in the Reynolds stress calculation per se but that the sensitivity might vary with acoustic signal amplitude and thus be affected by changes in alignment, fouling, and battery voltage.

#### Benthic Acoustic Stress Sensor (BASS)

We plan to construct an instrument using four of the acoustic velocity sensors to study benthic boundary layer flows on the deep continental shelf, continental slope, and continental rise. The free stream velocity in these areas is expected to be the order of 10 cm/sec. In this case, a viscous sublayer will probably not exist. The constant stress layer will be approximately 2 meters thick and the logarithmic layer about 10 meters thick. The four sensors will be spaced through these layers in an attempt to obtain a profile. The lowest sensor will be 50 cm above the bottom, the next 1.2 M, the next 2.5 M, and the top sensor 6 M above the bottom. Figure 8 illustrates this instrument.

A staff rises from a weighted triangular frame, the sensors being secured to the staff. The base contains the buoyancy, electronics package, and batteries, thus the flow will be disturbed by this roughness element for about 1 meter above the bottom. However, the upstream disturbance due to the base should be minimal and the sensors are upstream for flow directions covering perhaps  $240^{\circ}$ . Except for the lowest sensor, the flow is only disturbed behind the staff. There will be periods of disturbed flow when the measurements cannot be used; however, these will be infrequent with luck. We feel a rigid mounting is necessary for measurements at this scale and thus must suffer the consequences of interference by the structure. The bulk of the structure has been put low for stability. The instrument will be lowered by cable. Tilt and a single velocity component will be acoustically telemetered to the surface so the suitability of a selected site can be determined before the cable is released. First, the velocity will be noted with the BASS near the bottom. If the velocity is reasonable, it will be lowered to the bottom and some slack paid out. If the tilt is reasonable and the velocity remains reasonable, the cable will be released. Otherwise, BASS will be recovered and a new site selected.



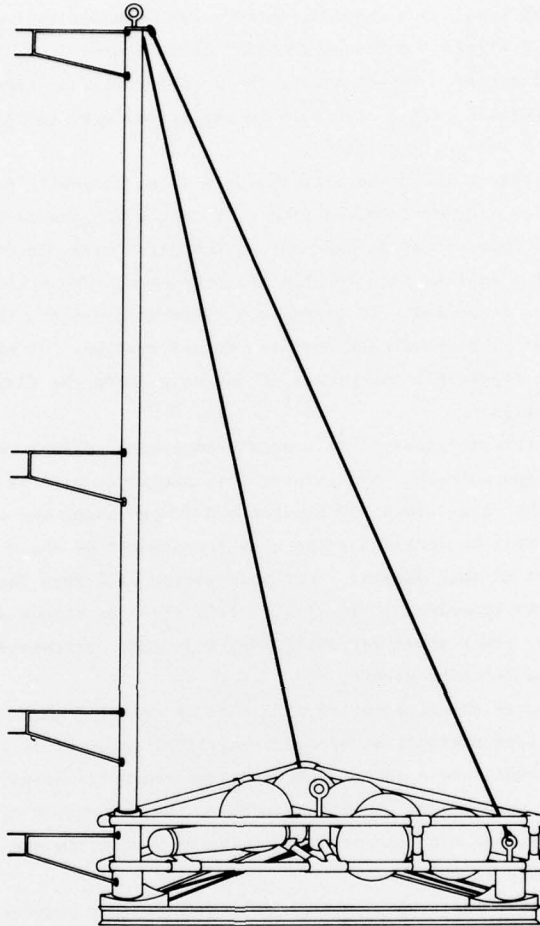

FIGURE 8: Benthic Acoustic Stress Sensor. The top velocity sensor is 6 M above the base.

Recovery of BASS by acoustic command will entail dropping the weighted base of the frame. The instrument will be tracked to the surface acoustically where it will be recovered with the aid of a flashing light and radio beacon.

A round of measurements will be made each 750 ms to avoid aliasing in currents up to 10 cm/sec. Each round generates 192 bits of data which,

with housekeeping bits and interrecord gaps, allows something more than 12 hours of continuous recording with a Sea Data digital cassette recorder. Initially a single continuous run will be most useful as it will cover a full tidal period. Subsequently, the sampling will be programmed to obtain information over 3 days to note variations with change in mesoscale activity or internal sea state.

The program for processing the data is as follows: for each sample the velocity will be resolved into  $u$ ,  $v$ , and  $w$  components using three paths. If this vector is near one of the paths used, it will be recomputed substituting another path for the disturbed one. The  $w$  component will be checked for zero mean. If there is a systematic offset, the data will be transformed by a coordinate rotation transformation. It may be necessary to do this separately for pieces of the data where the flow is from the same direction.

Then for each sensor the  $u$  and  $v$  components will be reduced to an amplitude and azimuth. Averages of this amplitude will be taken for sections of the data between 10 minutes and 1 hour long, and variations from this mean will be recorded along with the product of the  $u$  variation and  $w$  component at each sample. This information will form the time series data for the experiment. It will contain the  $u$  magnitude and azimuth, the  $w$  velocity, the  $u$  speed variation, and a product corresponding to an instantaneous Reynolds stress.

Pieces of the time series will then be selected which appear to behave similarly, for example, an accelerating tidal interval or a decelerating tidal interval, and a set of frequency analyses will be performed on the data: the spectrum of  $u$  for each sensor, the cospectrum of  $u$  and  $w$  for each sensor, and the coherency and phase of  $u$  velocity and of  $w$  velocity between pairs of sensors.

With this instrument we hope to extend benthic boundary layer velocity observations deeper into the sea where mean velocities and shear stresses are lower. We hope to observe mean profiles, Reynolds stress levels, and transient phenomena in these environments.

#### Discussion

Discussion of this and another paper opened the question of how small an acoustic travel time sensor might reasonably be made. As the size is decreased, the time difference for any given velocity decreases but the timing errors remain fixed. This means the velocity uncertainty increases. At the same time, the small scale eddies accessible with the smaller sensor

have characteristic velocities that are less than those of the larger eddies. At some scale, the velocity uncertainty equals the turbulent velocity fluctuations one expects to see. This crossover point depends on the dissipation constants one uses but an estimate of turbulent velocity fluctuations of 5 mm/sec for an eddy scale of 3 cm seems about right and this matches a probable velocity uncertainty (1 Hz bandwidth) of 5 mm/sec for a 3 cm path length. Thus a sensor smaller than 3 cm with our present electronics will be unable to resolve the velocities associated with 3 cm scale velocity fluctuations. A sensor with an acoustic path 5 cm long would be practical for oceanic work.

#### REFERENCES

1. Gytte, Trygve (1975) "Ultrasonic Measurements of Ocean Currents Down to 1 mm/sec," Conference Proceeding #32 of the IERE Conference on Instrumentation in Oceanography, 23-25 September 1975, University College N. Wales, Bangor, U.K., pp 69-80.
2. Williams, A.J. (1974) "Free-Sinking Temperature and Salinity Profiler for Ocean Microstructure Studies," Ocean '74 IEEE International Conference on Engineering in the Ocean Environment, Vol II, Institute of Electrical and Electronic Engineers, Inc., 345 East 47th St., New York New York 10017, catalog #74, CH0873-0 OCC, pp 279-283.

#### ACKNOWLEDGEMENTS

Williams received support for this work from ONR Contract N00014-74-CO262 NR 083-004. Tochko was supported by the Woods Hole Oceanographic Institution/Massachusetts Institute of Technology Joint Program in Ocean Engineering.

MANDATORY DISTRIBUTION LIST

FOR UNCLASSIFIED TECHNICAL REPORTS, REPRINTS, & FINAL REPORTS  
PUBLISHED BY OCEANOGRAPHIC CONTRACTORS  
OF THE OCEAN SCIENCE AND TECHNOLOGY DIVISION  
OF THE OFFICE OF NAVAL RESEARCH

(REVISED FEBRUARY 1978)

1	Director of Defense Research and Engineering Office of the Secretary of Defense Washington, D.C. 20301 ATTN: Office Assistant Director (Research)	1	National Oceanographic Data Center National Oceanic & Atmospheric Administration 3300 Whitehaven St., N.W. Washington, D.C. 20235
	Office of Naval Research Arlington, VA 22217	12	Defense Documentation Center Cameron Station Alexandria, VA 22314
1	ATTN: (Code 460)		Commander Naval Oceanographic Office Washington, D.C. 20373
1	ATTN: (Code 102-OS)	1	ATTN: Code 1640
6	ATTN: (Code 102IP)	1	ATTN: Code 70
1	ATTN: (Code 200)		
1	CDR J. C. Harlett, (USN) ONR Representative Woods Hole Oceanographic Inst. Woods Hole, MA 02543	3	NORDA 430 NSTL Station, MS 39529
1	Office of Naval Research Branch Office 495 Summer Street Boston, MA 02210	2	CO NORDA NSTL Station, MS 39529
	Director Naval Research Laboratory Washington, D.C. 20375		
6	ATTN: Library, Code 2620		