

AD A051434



AD

Reports Control Symbol
OSD-1366

RESEARCH AND DEVELOPMENT TECHNICAL REPORT
ECOM 77-7

12
69

AN OPTICAL SYSTEM FOR PROFILING WIND
AND REFRACTIVE-INDEX FLUCTUATION

AD NO. _____
DDC FILE COPY

By

G. R. Ochs

Ting-i Wang

E. J. Goldenstein

DDC
RECEIVED
MAR 20 1978
RECEIVED
B

For

Atmospheric Sciences Laboratory

U.S. Army Electronics Command

White Sands Missile Range, New Mexico 88002

October 1977

Approved for public release; distribution unlimited.

ECOM

UNITED STATES ARMY ELECTRONICS COMMAND - FORT MONMOUTH, NEW JERSEY 07703

NOTICES

Disclaimers

The findings in this report are not to be construed as an official Department of the Army position, unless so designated by other authorized documents.

The citation of trade names and names of manufacturers in this report is not to be construed as Official Government indorsement or approval of commercial products or services referenced herein.

Disposition

Destroy this report when it is no longer needed. Do not return it to the originator.

The U.S. Army Electronics Command, Atmospheric Sciences Laboratory
Scientific Monitor was Mr. T. H. Pries

Available as NOAA TR ERL WPL-31, for sale by the
National Technical Information Service
Operations Division
Springfield, Virginia 22151

REPORT DOCUMENTATION PAGE		READ INSTRUCTIONS BEFORE COMPLETING FORM
1. REPORT NUMBER ECOM-77-7	2. GOVT ACCESSION NO.	3. RECIPIENT'S CATALOG NUMBER
4. TITLE (and Subtitle) AN OPTICAL SYSTEM FOR PROFILING WIND AND REFRACTIVE-INDEX FLUCTUATION		5. TYPE OF REPORT & PERIOD COVERED
6. AUTHOR(s) G. R./Ochs, Ting-i/Wang, E. J./Goldenstein		6. PERFORMING ORG. REPORT NUMBER
9. PERFORMING ORGANIZATION NAME AND ADDRESS National Oceanic and Atmospheric Administration Environmental Research Laboratories Boulder, Colorado 80302		8. CONTRACT OR GRANT NUMBER(s)
11. CONTROLLING OFFICE NAME AND ADDRESS Atmospheric Sciences Laboratory US Army Electronics Command White Sands Missile Range, New Mexico 88002		10. PROGRAM ELEMENT, PROJECT, TASK AREA & WORK UNIT NUMBERS W43P6S 76-8016
14. MONITORING AGENCY NAME & ADDRESS (if different from Controlling Office)		12. REPORT DATE Oct 1977
		13. NUMBER OF PAGES 13
		15. SECURITY CLASS. (of this report) Unclassified
		15a. DECLASSIFICATION/DOWNGRADING SCHEDULE
16. DISTRIBUTION STATEMENT (of this Report) DISTRIBUTION STATEMENT A Approved for public release; Distribution Unlimited		
17. DISTRIBUTION STATEMENT (of the abstract entered in Block 20, if different from Report) Approved for public release; distribution unlimited.		
18. SUPPLEMENTARY NOTES		
19. KEY WORDS (Continue on reverse side if necessary and identify by block number) 1. Crosswind 2. Remote Sensing Instrument 3. Wind Profiling 4. Refractive Index Profiling 5. Optical Crosswind System 6. Anemometry (C sub n squared)		
20. ABSTRACT (Continue on reverse side if necessary and identify by block number) An instrument is described that measures the crosswind and the refractive-index structure parameter (C_n^2) at six locations along an optical path. Operating instructions, calibration procedures, and circuit diagrams are included.		

037620 Liu

TABLE OF CONTENTS

	Page
ABSTRACT	
1. INTRODUCTION	1
2. DESCRIPTION OF THE INSTRUMENT	1
3. OPERATING PROCEDURE	4
4. ALIGNMENT PROCEDURE	6
4.1 Optical Alignment	
4.2 Electronic Calibration	
5. REFERENCES	8
APPENDIX A. Circuit Diagrams	9 - 13

ACCESSION for		
NTIS	White Section	<input checked="" type="checkbox"/>
DDC	Buff Section	<input type="checkbox"/>
UNANNOUNCED <input type="checkbox"/>		
JUSTIFICATION _____		
BY _____		
DISTRIBUTION/AVAILABILITY CODES		
Dist.	AVAIL. and/or	SPECIAL
A		

Preceding Page BLANK

AN OPTICAL SYSTEM FOR PROFILING WIND
AND REFRACTIVE-INDEX FLUCTUATION

G. R. Ochs, Ting-i Wang, and E. J. Goldenstein

An instrument is described that measures the crosswind and the refractive-index structure parameter (C_n^2) at six locations along an optical path. Operating instructions, calibration procedures, and circuit diagrams are included.

1. INTRODUCTION

Recent theoretical and experimental work has shown that it is possible to measure the transverse wind across an optical path, and the refractive-index structure parameter (C_n^2) along the path, by observing the scintillation of an extended incoherent light source (Ochs et al., 1976a; Wang et al., 1978; accepted by JOSA). In fact there are distinct advantages over the use of coherent light sources because the deleterious effects of both the saturation of scintillation for paths of high integrated refractive turbulence and of the inner scale of refractive turbulence on short paths are largely eliminated. It has also been shown that by using the proper proportions of transmitter and receiver aperture diameters, it is possible to peak up the measurement in different portions of the path.

Cross path techniques are also effective in restricting the measurement to a portion of the optical path (Wang et al., 1974; Ochs et al., 1976b). This technique requires more apertures, however, and the array aperture and spacing must be rather large to avoid saturation effects on paths of several kilometers. While in principle rather sharp path definition may be obtained by cross path techniques, in practice on paths of 0.5 km or more, the intermittent nature of C_n^2 seems to require impractically long averaging times and results in somewhat broader weighting functions.

Considerations such as these led us to abandon the original crossed-path proposal and to develop a profiler based upon the use of a single extended incoherent transmitting source with two tangent receiver apertures for each path location to be measured.

2. DESCRIPTION OF THE INSTRUMENT

The transmitter consists of two incoherent light sources 8.4 and 27.9 cm in diameter. Both use quartz-iodine lamps. The smaller source uses a frosted bulb at the focus of a concave mirror; the larger source has its lamp at the focus of a fresnel lens and uses a separate piece of frosted glass to insure sufficient uniformity of illumination over the aperture.

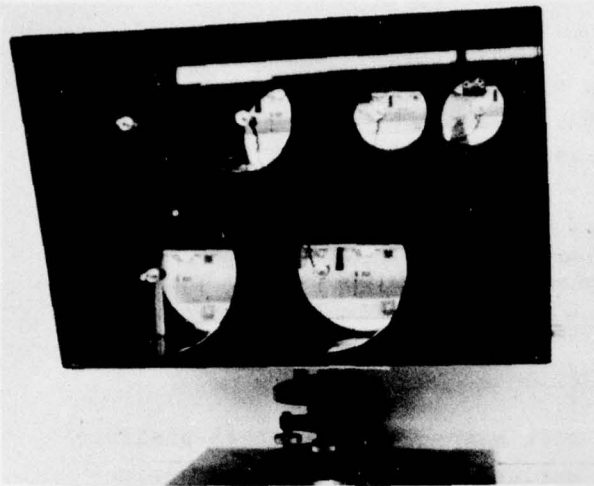

Figure 1. The optical receiver

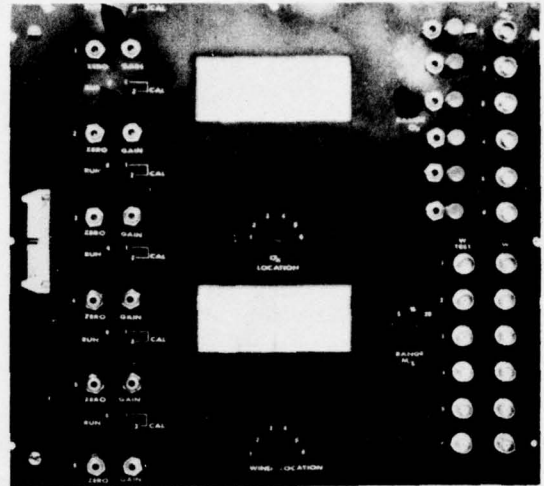

Figure 2. The signal processor

The receiver (Figure 1) has three pairs of tangent apertures, 15.2, 9.8, and 6.7 cm in diameter. Dual photodiodes placed at the focus of concave mirrors measure the irradiance of the apertures. By spacing the transmitters and aligning the receiver properly, the irradiance of the six apertures by one transmitter is measured by one group of six diodes, and the irradiance of the six apertures by the second transmitter is measured by the second set of six photodiodes. In this way six transmitter - receiver pair aperture ratios are obtained with two transmitting apertures and six receiving apertures.

Twelve preamplifiers at the receiver provide both a low gain signal suitable for C_n^2 measurement and a higher gain signal subject to limiting for wind measurement purposes. The signal processor (Figure 2) uses this information to calculate transverse wind and also C_n^2 at six locations along the optical path.

A block diagram of the circuit used to compute wind and C_n^2 at one path location is shown in Figure 3. Six of these circuits, which differ only in calibration, are used so that measurements are made simultaneously at the six locations. The circuit used to compute wind utilizes the slope system and is similar to that employed in the saturation resistant optical wind measurement systems. The wind calibration is independent of path length over the range 0.5 - 2.0 km.

The C_n^2 circuit is arranged so that, for received signals A and B, a calibrated measurement of the ratio

$$\sigma_I^2 = \frac{\langle (A-B)^2 \rangle}{(A_0 + B_0)^2} \quad (1)$$

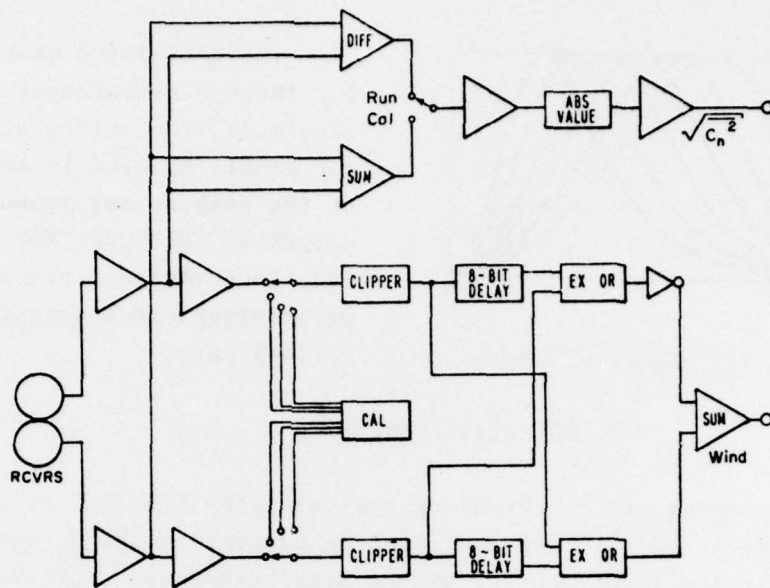

Figure 3. Block diagram of system

is obtained. It can be shown that (Wang et al., 1978)

$$C_n^2 = \frac{K \sigma_I^2 D_t^{7/3}}{L^3} \quad (2)$$

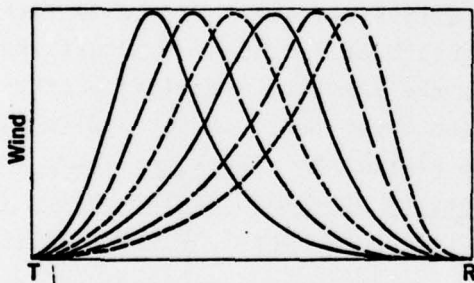

Fig. 4. Individual wind weighting functions

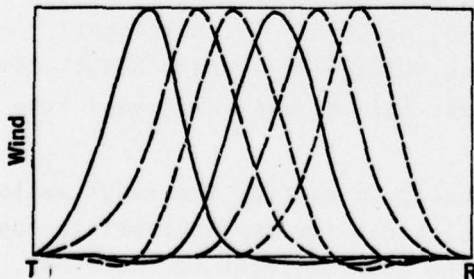

Fig. 5. Combined wind weighting functions

where L is the path length, D_t is the incoherent transmitting aperture diameter, and K is a function of the ratio of transmitting and receiving aperture sizes.

The six path weighting functions for wind are shown in Figure 4. Any one of these six outputs can be displayed on the instrument panel meter, and all are available from BNC outputs on the panel. By a linear combination of these weighting functions, somewhat sharper functions can be obtained. Such a linear combination is made in the instrument and a second set of wind outputs is available on the panel with the weighting functions shown in Figure 5.

The instrument is primarily designed to measure wind profiles, and the optical arrangement is not optimum for C_n^2 . Useful measurements can be made, however.

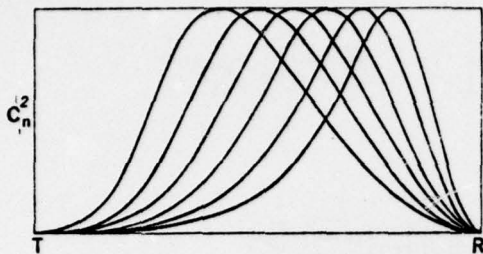

Fig. 6. C_n^2 weighting functions

The calculated weighting functions for the C_n^2 measurement are shown in Figure 6. The aperture sizes chosen for profiling wind in the middle 2/3 of the path do not produce the same weighting functions for C_n^2 ; hence the functions obtained are not symmetric with respect to the center of the optical path.

3. OPERATING PROCEDURE

The instrument may be set up on optical paths from 0.5 to 2 km long. The light sources and the receiver must be mounted on solid, vibration-free mounts. Place the light sources at the same height with the smaller diameter source on the left, as viewed from the receiver. The light sources should have a horizontal angular separation of 6.8 mrad as viewed from the receiver.

An initial receiver alignment may be made by using the sight built into the receiver. However this optical alignment must be checked by observing the images of the light sources on each dual photodiode. Hold an inspection mirror at 45 degrees in front of each of the six receiving mirrors to observe the light source images on the photodiode active surface. If the 12 light source images are not focused on the respective photodiodes, readjust the pointing. If this cannot be accomplished, the relative positions of the individual photodiodes can be changed by loosening the lock nut and knurled nut that holds the photodiode mount to the plexiglass. Both the light source image position and focus are critical to proper operation of the unit. The importance of a solid mount such as a concrete pier cannot be overstressed.

The front panel controls on the processor (Figure 2) are divided into groups numbered 1 (measurement position nearest light) to position 6 (nearest receiver), with a function switch and zero and gain control for each. Full scale wind measurement may be set for 5, 10, or 20 m/s (± 4 volts out). A meter deflection to the right or a positive voltage at a wind output indicates a wind direction from left to right across the optical path as viewed from the receiver.

The zero and gain settings may be checked by setting the range switch at 10 m/s and adjusting for zero and ± 4 volts out for the appropriate function switch settings for each path position. The wind calibration, once set, remains correct over the operating path range of the instrument.

The C_n^2 calibration must be set up individually for each path length. Once set up for a particular path length, however, it should require only occasional checks. We proceed by rewriting equations (1) and (2) as

$$\begin{aligned}\sqrt{C_n^2} &= \frac{[0.47 K^{1/2} D_t^{7/6}] [1.26 G |A-B|]}{L^{3/2} [0.47(A_0+B_0)] G} \\ &= \frac{K'S}{L^{3/2} G C}\end{aligned}\tag{3}$$

In this form the constants represent measureable instrument values as follows:

G = gain setting (1, 10, or 100) on the front panel.

$S = [1.26 G |A-B|]$ = RMS signal fluctuation. (For a gaussian amplitude distribution $\sqrt{\langle(A-B)^2\rangle}/|A-B| = 1.26$.) An absolute value circuit measures $|A-B|$ in the instrument.

$C = [0.47(A_0+B_0)]$ = DC signal level determined by setting toggle switches to calibrate (DC coupling), and turning the light sources on and off at night.

K' = calibration constant derived from propagation theory for each position as follows:

Position	K'
1	0.141
2	0.0853
3	0.0588
4	0.176
5	0.137
6	0.118

The system can be calibrated by setting the DC gain with the panel gain controls. For example, to calibrate position 1 on a 500-m path for full scale output of $\sqrt{C_n^2} = 2 \times 10^{-6} \text{ M}^{-1/3}$ (4 volts). and $G=10$, set the toggle switches to calibrate and adjust the DC gain at night to

$$\begin{aligned}C &= \frac{K'S}{L^{3/2} G \sqrt{C_n^2}} \\ &= \frac{0.141 \times 4}{500^{3/2} \times 10 \times 2 \times 10^{-6}} \\ &= 2.52 \text{ volts}\end{aligned}$$

4. ALIGNMENT PROCEDURE

All electronic adjustments are in the processor. The preamplifiers in the receiver contain no adjustments. Remove the processor from its case by removing the panel screws. All components are fastened to the front panel. An individual circuit board is used for each path position, starting with the top board which processes position Figure 7. The bottom (7th) board is the combiner board and requires no adjustment. All boards except the combiner board are identical and except for calibration frequencies the following alignment procedure applies.



Figure 7. Processor board

1. connect the receiver and processor units. Set the range switch to 10 m/s and the C_n range switch to X10. Set pot D for 40 kHz at TP 29.
2. With the function switch on CAL (either 1 or 2) set pot C to obtain the frequencies at T14 or T16.

Board	Calibration Frequency
1	18.2 Hz
2	25.2
3	33.8
4	13.4
5	18.0
6	23.1

3. Cover the optics with opaque material and with the function switch in RUN position, set pots A and B for +5 volts average at TP15 and TP17.
4. Set the panel zero pot for zero wind reading at the W TEST outputs, with the function switch set to 0.
5. With the range switch set to 10 m/s, and the function switch set to CAL 2, set the panel gain pot for +4.0 volts at the W TEST output. Check for -4.0 volts in the CAL 1 position and reset the panel zero pot if necessary.
6. Set pot for full scale meter deflection with the function switch set to CAL 2.
7. With the σ_X gain panel controls fully CW (maximum gain) and the receiver covered with opaque material, adjust pot F for zero volts at the σ_X output.
8. Disconnect the receiver cable. Insert a sine wave test signal of about 2 volts RMS and 100 Hz at T1 or T3. With the σ_X range in the X10 position, adjust the panel σ_X gain to obtain +4.0 volts at the σ_X output. Then adjust pot G for full scale σ_X meter deflection. This procedure merely assures that a full scale σ_X meter reading corresponds to a σ_X output of 4.0 volts. The actual calibration procedure is explained under section 4. OPERATING PROCEDURE.
9. Observe a brightly illuminated white card with the receiver and set pot A' for zero volts at pin 6 of op amp N.

5. REFERENCES

- Ochs, G. R., S. F. Clifford, and Ting-i Wang (1976a): Laser wind sensing: the effects of saturation of scintillation, *Appl. Opt.* 15:403-408.
- Ochs, G. R., S. F. Clifford, and Ting-i Wang (1976b): Wind and C_n^2 profiling with crossed laser beams and spatial filter detectors, NOAA Tech. Rept. ERL 367-WPL 45.
- Wang, Ting-i, G. R. Ochs, and S. F. Clifford (1978): A saturation resistant optical scintillometer to measure C_n^2 . (Accepted for publication, JOSA).
- Wang, Ting-i, S. F. Clifford, and G. R. Ochs (1974): Wind and refractive-turbulence sensing using crossed laser beams, *Appl. Opt.* 13:2602-2608.

APPENDIX

PHOTODIODE NUMBERS CORRESPONDING TO PREAMP OP AMPS. ONE PINSPOOT 2D PER MIRROR. LEFT PHOTO-DIODES LOOK SMALL TRANSMITTER; RIGHT ONES AT LARGE TRANSMITTERS.

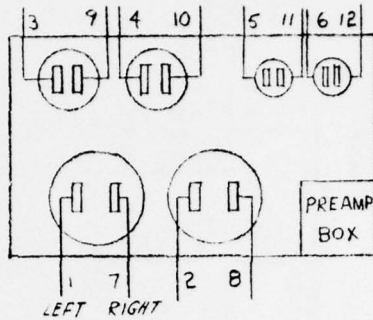

FRONT VIEW PHOTO-DIODES FACE THE MIRRORS

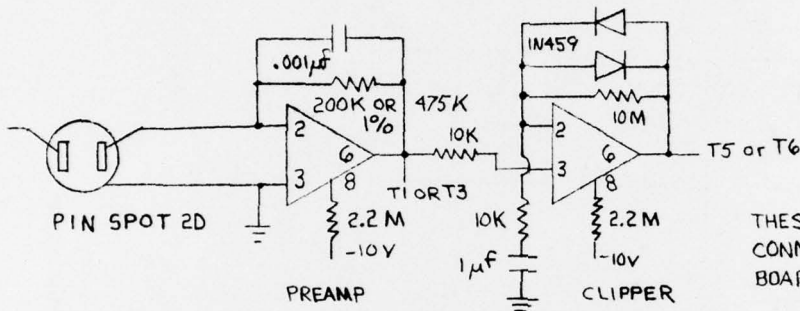

ONE CIRCUIT FOR EACH PHOTO-DIODE. SOME CIRCUITS HAVE DIFFERENT VALUES OF FEEDBACK RESISTORS.

THESE OUTPUTS GO TO A 34 PIN CONNECTOR. THE NUMBERS AND BOARD DESTINATIONS ARE GIVEN.

OPTICS PREAMP BOX			CABLE PIN		RECEIVER BOX	
PHOTODIODE	PREAMP CLIPPER	FEEDBACK RESISTOR	PREAMP	CLIPPER	BOARD #	INPUT POINT PREAMP, CLIP
1	1	200K	18	12	1	T1 T5
2	2	200K	2	29	1	T3 T6
GND			1		1	-
3	3	475K	3	13	2	T1 T5
4	4	475K	20	30	2	T3 T6
GND			19		2	-
5	5	475K	21	14	3	T1 T5
6	6	475K	5	31	3	T3 T6
GND			4		3	-
7	7	200K	6	15	4	T1 T5
8	8	200K	23	32	4	T3 T6
GND			22		4	-
9	9	475K	24	16	5	T1 T5
10	10	475K	8	33	5	T3 T6
GND			7		5	-
11	11	475K	9	17	6	T1 T5
12	12	475K	26	34	6	T3 T6
GND			25		6	-
+10V			10			+10V
-10V			27			-10V
GND			11, 28			GND

PREAMPLIFIER

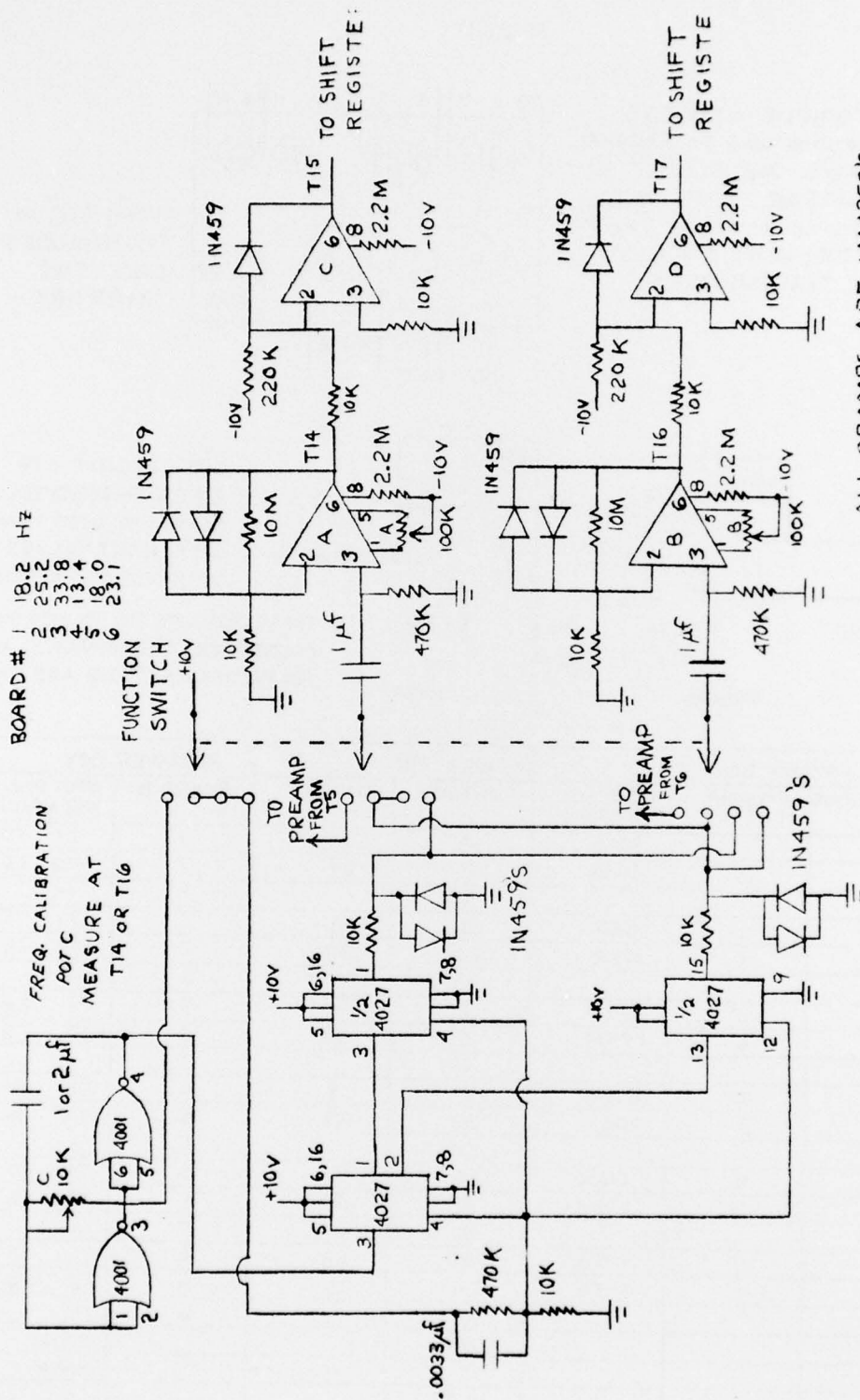

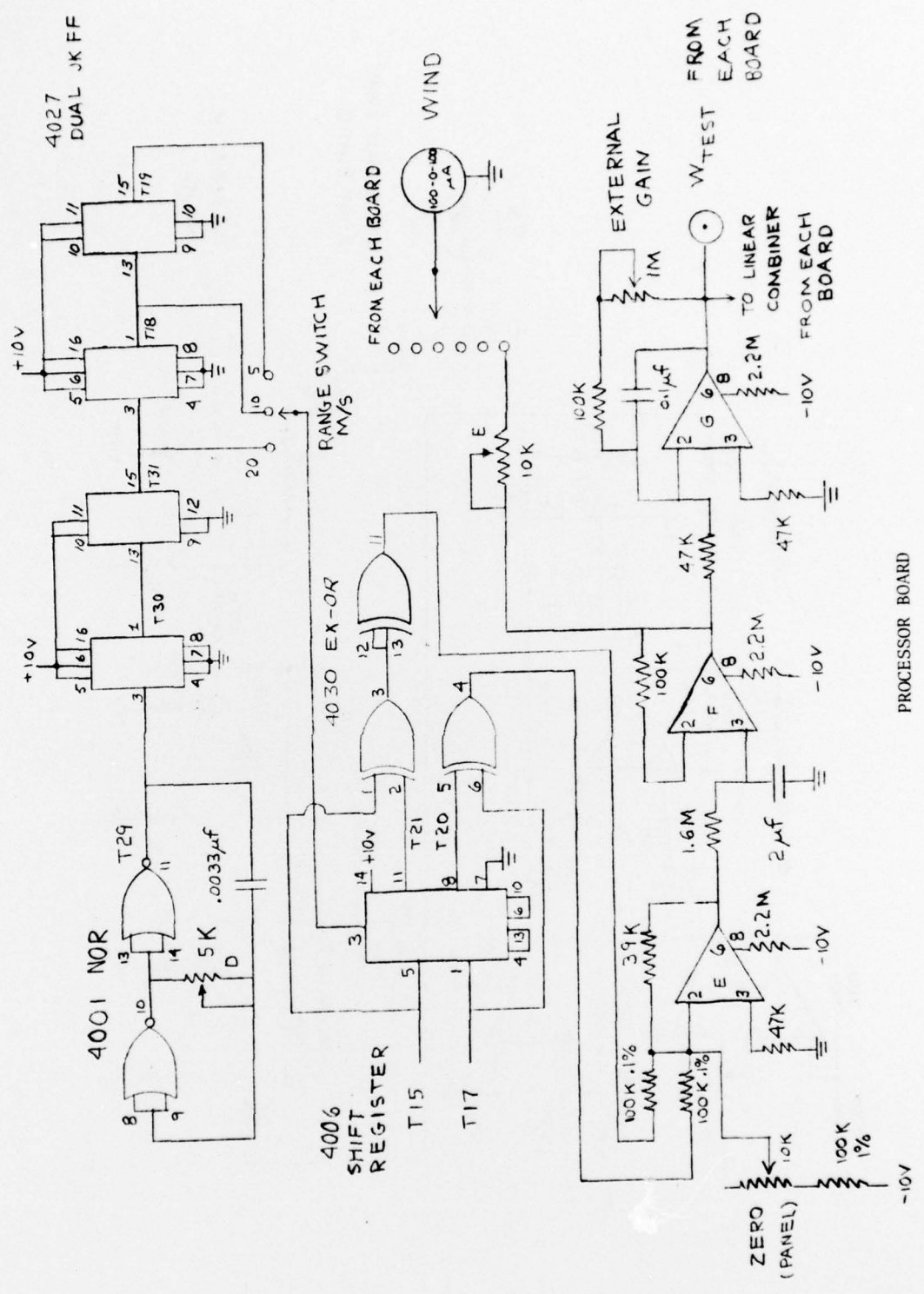

PROCESSOR BOARD

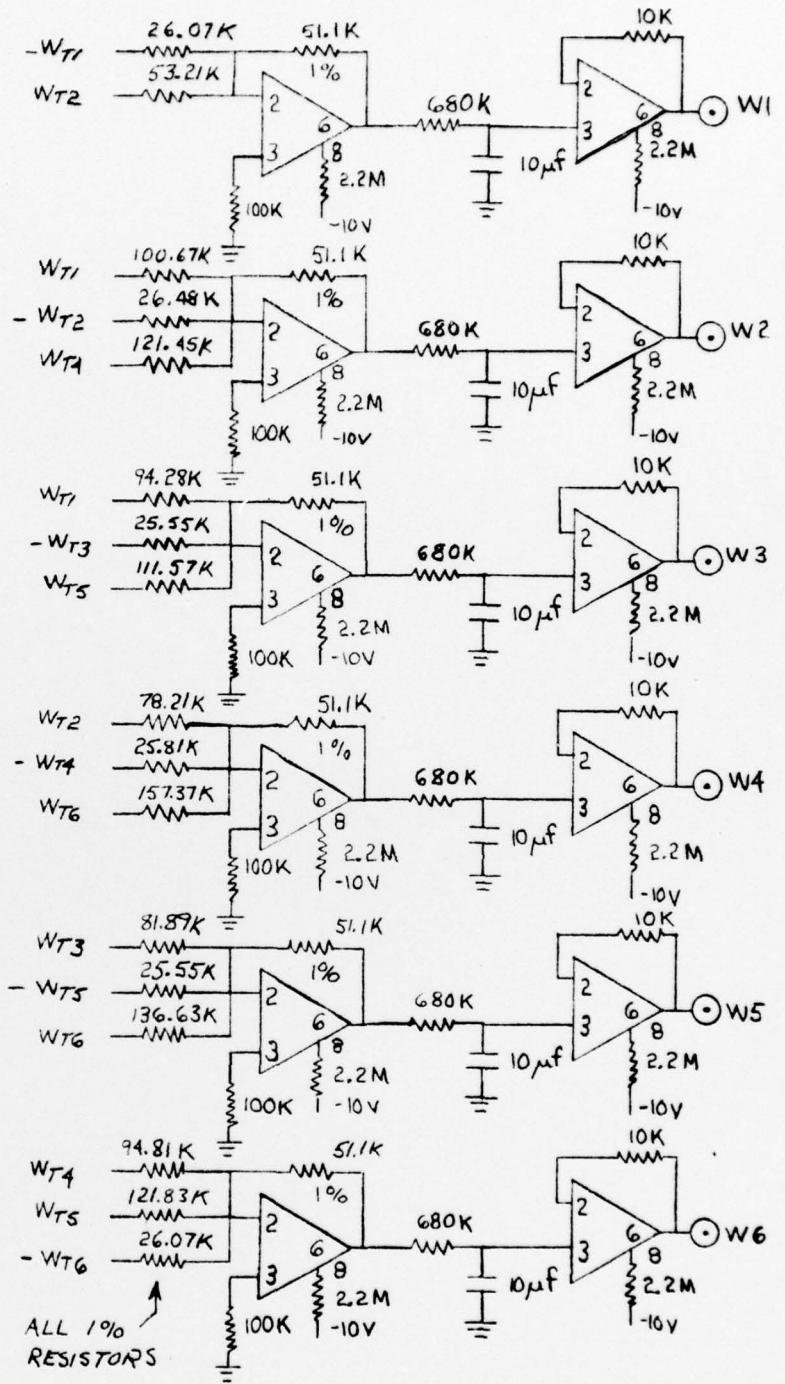
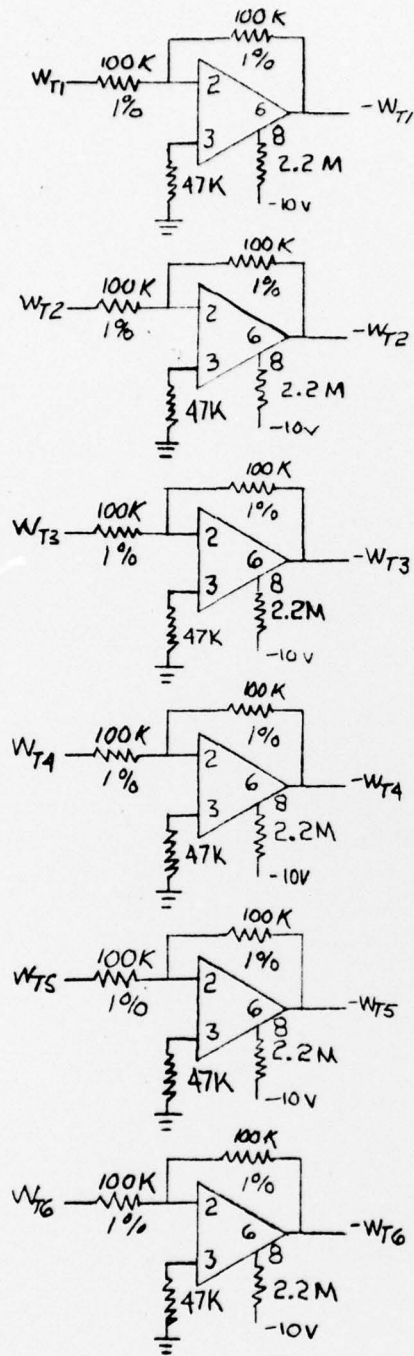

COMBINER BOARD