

AD-A051 318

KAMAN AEROSPACE CORP BLOOMFIELD CONN  
ADVANCED DEVELOPMENT OF A HELICOPTER ROTOR ISOLATION SYSTEM FOR--ETC(U)  
DEC 77 R JONES, J H MCGARVEY

F/G 1/3

DAAJ02-72-C-0082

UNCLASSIFIED

R-1396-1

USAAMRDL-TR-77-23A

NL

| OF |

AD  
A051318



END  
DATE  
FILMED

4-78

DDC

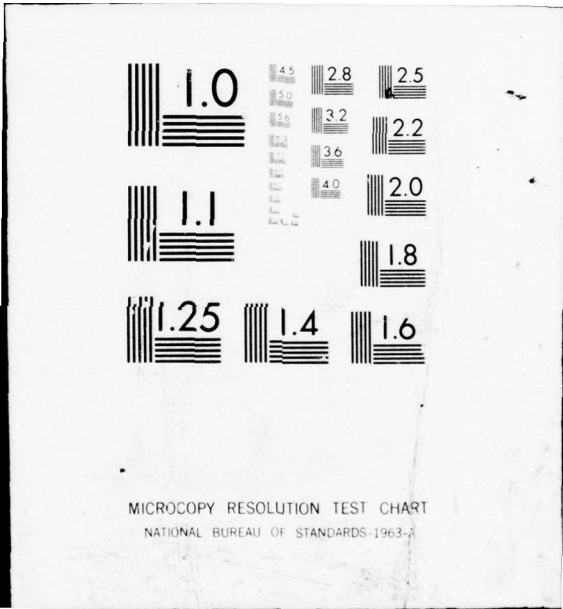

AD A051318

USAAMRDL-TR -77-23A

12  
B.S.



**ADVANCED DEVELOPMENT OF A HELICOPTER ROTOR ISOLATION SYSTEM FOR IMPROVED RELIABILITY**

**Volume I - Summary Report**

Kaman Aerospace Corporation  
Bloomfield, Connecticut 06002

DDC  
MAR 16 1978  
F

DDC FILE COPY

**December 1977**

**Final Report for Period June 1972 - February 1976**

Approved for public release;  
distribution unlimited.

Prepared for  
APPLIED TECHNOLOGY LABORATORY  
U. S. ARMY RESEARCH AND TECHNOLOGY LABORATORIES (AVRADCOM)  
Fort Eustis, Va. 23604

## APPLIED TECHNOLOGY LABORATORY POSITION STATEMENT\*

This report documents the culmination of a U.S. Army Air Mobility Research and Development Laboratory (USAAMRDL) search for an effective, lightweight, practical helicopter rotor isolation system. At the outset of this program, the challenge was to successfully flight-demonstrate an isolation system capable of isolating a helicopter's fuselage from vertical and inplane rotor excitation, while being sufficiently light in weight, small in size, and mechanically simple to warrant use in current or proposed new helicopters. This search, some ten years in duration, consisted of a series of investigations wherein consideration was given to both passive and active isolation concepts. For these reasons, it was deemed appropriate that USAAMRDL provide a program review to accompany this report. Your attention is invited to this program review which provides a "thumb-nail" sketch of these USAAMRDL-sponsored pursuits together with some observations regarding related corporate research and development activities within the helicopter industry. The results of this concluding effort are in two volumes: Volume I being a Summary Report; and Volume II details of the analyses and tests of this developmental program.

For many years, the vibration specification to which helicopters had been designed was MIL-H-8501A. A related specification, MIL-S-8698, "required" that suitable antivibration provisions be used in order for the developed helicopter to comply with MIL-H-8501. This had little meaning, for a viable isolation system concept did not exist. Invariably, for military helicopters, a Model Specification was negotiated between the user and the developer providing for a relaxed specification. The resultant deleterious effects of vibration are well documented.

In this developmental program, an isolation system employing the Kaman Dynamic Antiresonant Vibration Isolator (DAVI) was flight test demonstrated on an Army UH-1H helicopter. These results, as well as those by Bell and Boeing-Vertol, discussed in the program review, were most successful. The DAVI-modified UH-1H is estimated to save \$50 per flight-hour in parts and labor. If 1,000 UH-1's were retrofitted to achieve lower costs associated with volume production, the total cost of retrofitting is estimated to be \$7,000,000, whereas an annual savings of \$12,000,000 is forecast. Army development and implementation of a plan to retrofit its UH-1H fleet is recommended. The optimized antiresonant isolation systems developed by Bell and Boeing-Vertol for the Model 206A and BO-105, respectively, yield vibration levels below the more stringent requirements of the UTTAS and AAH. It is evident that antiresonant rotor isolation has considerable potential for future military and commercial helicopters. Isolation system performance, particularly weight penalty, will be even better if it is an integral part of the helicopter's development.

These combined Army-industry results should mark the beginning of a new era - an era wherein the Army and industry have matured so that rotor isolation can be proposed as an integral part of any new helicopter to be developed, confident that such a proposal will no longer be viewed as a sign of weakness or inability to design and deliver, without some form of a "crutch," a helicopter satisfying its vibration requirements. Instead, it is prudent recognition that today's helicopters experience long costly "cut and try" developmental programs to comply with challenging design specifications, and rotor isolation is recognized as a practical solution to the vibration challenge.

This ten-year program was conducted under the technical cognizance of Joseph H. McGarvey, Military Operations Technology Division.

\*On 1 September 1977, after this report had been prepared, the name of this organization was changed from Eustis Directorate, U.S. Army Air Mobility Research and Development Laboratory to Applied Technology Laboratory, U. S. Army Research and Technology Laboratories (AVRADCOM).

### DISCLAIMERS

The findings in this report are not to be construed as an official Department of the Army position unless so designated by other authorized documents.

When Government drawings, specifications, or other data are used for any purpose other than in connection with a definitely related Government procurement operation, the United States Government thereby incurs no responsibility nor any obligation whatsoever; and the fact that the Government may have formulated, furnished, or in any way supplied the said drawings, specifications, or other data is not to be regarded by implication or otherwise as in any manner licensing the holder or any other person or corporation, or conveying any rights or permission, to manufacture, use, or sell any patented invention that may in any way be related thereto.

Trade names cited in this report do not constitute an official endorsement or approval of the use of such commercial hardware or software.

### DISPOSITION INSTRUCTIONS

Destroy this report when no longer needed. Do not return it to the originator.



UNCLASSIFIED

SECURITY CLASSIFICATION OF THIS PAGE (When Data Entered)

19 REPORT DOCUMENTATION PAGE		READ INSTRUCTIONS BEFORE COMPLETING FORM
1. REPORT NUMBER USAAMRDL-TR-77-23A	2. GOVT ACCESSION NO.	3. RECIPIENT'S CATALOG NUMBER
4. TITLE (and Subtitle) ADVANCED DEVELOPMENT OF A HELICOPTER ROTOR ISOLATION SYSTEM FOR IMPROVED RELIABILITY, VOLUME I. SUMMARY REPORT.		5. TYPE OF REPORT & PERIOD COVERED Final Report - 6/72 to 2/76
7. AUTHOR(s) Robert Jones Joseph H. McGarvey		6. PERFORMING ORG. REPORT NUMBER R-1396-1 8. CONTRACT OR GRANT NUMBER(s) DAAJ02-72-C-0082
9. PERFORMING ORGANIZATION NAME AND ADDRESS Kaman Aerospace Corporation Bloomfield, Connecticut 06002		10. PROGRAM ELEMENT, PROJECT, TASK AREA & WORK UNIT NUMBERS 63204A 1F163204DB38 009 EK
11. CONTROLLING OFFICE NAME AND ADDRESS Applied Technology Laboratory, U. S. Army Research and Technology Laboratories (AVRADCOM) Fort Eustis, Virginia 23604		12. REPORT DATE December 1977
14. MONITORING AGENCY NAME & ADDRESS (if different from Controlling Office) Final rept. Jun 72 - Feb 76		13. NUMBER OF PAGES 69
16. DISTRIBUTION STATEMENT (of this Report) 70p. Approved for public release; distribution unlimited.		15. SECURITY CLASS. (of this report) Unclassified
17. DISTRIBUTION STATEMENT (of the abstract entered in Block 20, if different from Report)		15a. DECLASSIFICATION/DOWNGRADING SCHEDULE
18. SUPPLEMENTARY NOTES Volume I of a two-volume report		
19. KEY WORDS (Continue on reverse side if necessary and identify by block number) Rotor Isolation      Vibration Isolation      Maintainability Helicopter Isolation      Antiresonant Isolation      Vibration Isolation      Reliability		
20. ABSTRACT (Continue on reverse side if necessary and identify by block number) This report includes the results of the analytical and experimental phases of a helicopter rotor isolation reliability and maintainability (R&M) program on a UH-1 helicopter, which was modified through the addition of a Dynamic Antiresonant Vibration Isolator (DAVI).  The final flight test phase demonstrated that the DAVI-modified vehicle had substantially lower vibration levels than the standard vehicle. Vertically,		

DDC  
RECEIVED  
MAR 16 1978  
RESERVED

404 362

LB

UNCLASSIFIED

SECURITY CLASSIFICATION OF THIS PAGE(When Data Entered)

20 (Continued)

the two-per-rev vibration level was reduced to less than one-fifth that of the standard vehicle through the transition speed range and less than one-half at high speeds. An R&M analysis indicated the Army could realize an annual cost savings of approximately \$12,000,000 if 1000 Army UH-1Hs were equipped with DAVI isolation systems. This savings is predicated on the following assumptions: (1) vibration-induced failures will be reduced in proportion to the vibration reduction afforded by the DAVI isolation system, and (2) the UH-1Hs are utilized at the rate of 20 flight-hours per month.

The reduction of the vibration level was achieved with an experimental DAVI isolation system weighing 2.31 percent of the 6600-pound design gross weight. Further refinements of this isolated system could reduce the weight to 1.27 percent of the design gross weight. For vehicles with higher predominant excitation frequencies than 10.8 Hertz for the UH-1H, the weight would be even less.

In the analytical phase, a dynamic analysis was done to determine the proper spring rates of the DAVI system to retain the same mounting points as the standard UH-1 isolation system and to retain dynamic characteristics and flying qualities similar to those of the UH-1H helicopter. Both static and dynamic stress analyses have shown that the DAVI and the structural modifications have adequate margins of safety and infinite life.

Component and system testing was done to substantiate the DAVI-isolated vehicle for flight. Component testing was done early in the program to determine the feasibility of the mechanical pivots and the elastomer selected for the design of the DAVI. System testing included a ground vibration survey of both the DAVI- and the standard-isolated vehicles, a proof test of the DAVI-modified vehicle, and a fatigue test of the DAVI isolation system.

The ground vibration survey showed that the DAVI-isolated system should give a substantial reduction in vibration as compared to the standard UH-1H helicopter. The proof tests showed that the DAVI-modified helicopter could withstand the 125 percent of limit load without failure or permanent set. A 100-hour fatigue test was completed on the DAVI system with no failure. This fatigue test was for 1.5 times the vibratory hub loads expected in flight.

Analysis of the results shows that the DAVI system has dynamic characteristics similar to the standard UH-1 helicopter and that the relative motion between fuselage and transmission is small. The angular misalignment of the engine driveshaft coupling is well within the allowable misalignment criteria.

UNCLASSIFIED

SECURITY CLASSIFICATION OF THIS PAGE(When Data Entered)

PREFACE

This program for flight testing a modified UH-1H helicopter with the Dynamic Antiresonant Vibration Isolator (DAVI) was performed by Kaman Aerospace Corporation, Division of Kaman Corporation, Bloomfield, Connecticut, under Contract No. DAAJ02-72-C-0082, for the U. S. Army Air Mobility Research and Development Laboratory, Eustis Directorate, Fort Eustis, Virginia.

The program was conducted under the technical direction of Mr. J. McGarvey, Military Operations Technology Division, USAAMRDL. At Kaman, Mr. H. Howes was Program Manager and Mr. R. Jones was Technical Monitor. Messrs J. Rembock and H. Cooke were responsible for the design and Mr. M. Tarricone for the structural analysis. In the test phases, Mr. E. Luff was responsible for the ground tests and Mr. F. Bill for the flight test phase. This testing was done under the supervision of Mr. A. D. Rita, Chief Flight Test Engineer.

Special acknowledgment is given to Bell Helicopter Corporation for their cooperation in furnishing reports, entering into discussions and giving recommendations for the design of the modified control system and of the magnitude of the main-rotor forces expected in flight.

or	White Section	<input checked="" type="checkbox"/>
US	Butt Section	<input type="checkbox"/>
DD		<input type="checkbox"/>
RECOMMENDATIONS		
SECTION		
BY	DISPOSITION/AVAILABILITY CODES	
	/ OF SPECIAL	
A		

Preceding Page BLANK - NOT FILMED

TABLE OF CONTENTS

	<u>Page</u>
PREFACE-----	3
LIST OF ILLUSTRATIONS-----	7
ROTOR ISOLATION - USAAMRDL PROGRAM REVIEW-----	9
DESIGN PHILOSOPHY-----	25
DESCRIPTION OF ISOLATION SYSTEMS-----	28
STANDARD UH-1H ISOLATION SYSTEM-----	28
UH-1H DAVI ISOLATION SYSTEM-----	28
STRUCTURAL MODIFICATION-----	37
CONTROL SYSTEM MODIFICATION-----	37
SYSTEM DEVELOPMENT SUMMARY-----	39
STRUCTURAL ANALYSES-----	39
FLYING QUALITIES ANALYSIS-----	39
COMPONENT TESTS-----	40
SYSTEM TESTS-----	41
FLIGHT TEST-----	48
AIRFRAME RESPONSE-----	48
RELATIVE DISPLACEMENT/COUPLING MISALIGNMENT-----	53
ROTOR BLADE STRESSES-----	53
CORRELATION-----	58
WEIGHT-----	60
DAVI RELIABILITY ANALYSES-----	62
FAILURE MODES AND EFFECTS ANALYSIS-----	62
COST EFFECTIVENESS-----	64



TABLE OF CONTENTS (Continued)

	<u>Page</u>
CONCLUSIONS-----	66
RECOMMENDATIONS-----	67
REFERENCES-----	68



LIST OF ILLUSTRATIONS

<u>Figure</u>		<u>Page</u>
1	Two-Bladed Case-----	13
2	Four-Bladed Case-----	13
3	Isolation vs Frequency Ratio-----	14
4	Early Version of Bell's Focused Pylon/Nodal Beam Isolation System-----	18
5	Recent Version of Bell's Focused Pylon/Nodal Beam Isolation System-----	18
6	Jet Ranger Flight Test Results-----	19
7	B0-105 Isolation System-----	21
8	B0-105 Vibration Levels-----	21
9	UH-1H Helicopter Serial Number 66-1093-----	29
10	Schematic of the Standard UH-1H Isolation System-----	30
11	Schematic of the UH-1H DAVI Isolation System-----	31
12	Transmission-Mount DAVI-----	33
13	DAVI Transmission Mount for UH-1H Helicopter-----	34
14	Lift-Link DAVI-----	35
15	Photograph of the Lift-Link DAVI Mount-----	36
16	Schematic of Engine-Transmission Installation-----	38
17	Schematic of Endurance Test Rig-----	42
18	Schematic Diagram of Proof-Load Test-----	44
19	Ground Vibration Test Setup-----	46
20	Accelerometer Locations-----	47

LIST OF ILLUSTRATIONS (Continued)

<u>Figure</u>		<u>Page</u>
21	Two-Per-Rev Vertical Response of the 8250-Pound UH-1H Helicopter-----	49
22	Two-Per-Rev Vertical Response of the 9500-Pound UH-1H Helicopter-----	49
23	Two-Per-Rev Lateral Response of the 8250-Pound UH-1H Helicopter-----	51
24	Two-Per-Rev Lateral Response of the 9500-Pound UH-1H Helicopter-----	51
25	Angular Misalignment of the Engine Drive Coupling in the DAVI-Modified UH-1H-----	54
26	UH-1H Moment Distribution-----	55
27	Main Rotor Blade Loads Comparison-----	57
28	Predicted and Actual Two-Per-Rev Vertical Responses of the UH-1H-----	59

## ROTOR ISOLATION - USAAMRDL PROGRAM REVIEW

This report represents the culmination of a U. S. Army Air Mobility Research and Development Laboratory (USAAMRDL) search for an effective, light weight, practical helicopter rotor isolation system. This search, some ten years in duration, consisted of a series of investigations wherein consideration was given to both passive and active isolation concepts. For these reasons, it was deemed appropriate that USAAMRDL provide a program review to accompany this report.

The sources, the problems, and the detrimental effects of high-level, low-frequency helicopter vibration are well known to the industry and the Army. The Army has long recognized the need for helicopter vibration reduction and, for many years, has sought to reduce vibration through research in rotor dynamics, structural dynamics, and vibration mitigation devices.

The major sources of these vibration problems are the rotor-induced shears and moments. These shears and moments produce a hub input at a frequency in the fixed system that is an integral multiple of the number of blades in the rotor system. The predominant excitation frequency is the n-th harmonic of an n-bladed rotor.

One means of vibration reduction, and perhaps the most viable near-term solution, is isolation of the complete fuselage from the rotor-induced forces - often referred to as rotor isolation. The Eustis Directorate, USAAMRDL, Fort Eustis, Virginia, subscribes to this viewpoint and has been sponsoring research in rotor isolation for the past ten years.

The concept of rotor isolation is not new. Conventional passive devices that isolate inplane rotor forces have been successfully incorporated into production helicopters for over fifteen years, the Army's UH-1 series helicopters being the most prominent case. The crux of helicopter rotor isolation is one of providing adequate low-frequency isolation without excessive relative displacement or loss of mechanical stability. Isolating the large vertical lifting forces of a helicopter rotor while maintaining a low relative displacement has precluded effective isolation in the vertical direction by conventional means. Three major analytical studies of isolating the fuselage from the rotor system were

conducted between 1957 and 1962 (References 1, 2, and 3). Reference 1, incidentally, is the earliest recorded investigation of vertical rotor isolation. All three studies reached the same basic conclusion: active systems were required to provide isolation in the vertical direction. Active devices require some form of external power (generally hydraulic, pneumatic, electric, or some combination of these), feedback loops employing servovalves, and electronic signal conditioning equipment. These systems lacked the simplicity and therefore the practicality to warrant their use in retrofitting current helicopters. As a result, full-scale experimental demonstration of the feasibility of these systems was not initiated.

Thus, at the outset of this USAAMRDL program, initiated some ten years ago, the challenge was to successfully flight-demonstrate an isolation system capable of isolating a helicopter's fuselage from vertical and inplane rotor excitation while being sufficiently light in weight, small in size, and mechanically simple to warrant use in current or proposed new helicopters.

In 1965, the Army received favorable replies to a letter for Information and Planning soliciting the helicopter industry's opinion regarding the timeliness of a parametric study of helicopter rotor isolation feasibility. The consensus of these replies also concurred in the soundness of restricting such a study to the less complex rigid-body analyses for assessing the relative merits of isolation system concepts with confirmatory tests of the best performing systems to follow. As the result of a competitive procurement in 1966, two analytical studies (one active, the other passive) were initiated to investigate the feasibility of helicopter rotor isolation. The results of these studies are reported in References 4 and 5.

- <sup>1</sup> Theobald and Jones, ISOLATION OF HELICOPTER ROTOR VIBRATION FORCES FROM THE FUSELAGE, Kaman Aircraft, Bloomfield, CT, WADC Technical Report 57-404, Wright Air Development Center, Dayton, OH, September 1957.
- <sup>2</sup> Crede and Cavanaugh, FEASIBILITY STUDY OF AN ACTIVE VIBRATION ISOLATOR FOR A HELICOPTER ROTOR, Barry Wright Corp., WADC Technical Report 58-163, Wright Air Development Center, Dayton, OH, October 1958.
- <sup>3</sup> Smollen, Marshall and Gabel, A SERVO-CONTROLLED ROTOR VIBRATION ISOLATION SYSTEM FOR THE REDUCTION OF HELICOPTER VIBRATION, Institute of Aerospace Sciences Paper No. 62-34, New York, NY, January 1962.
- <sup>4</sup> Schuett, PASSIVE HELICOPTER ROTOR ISOLATION USING THE KAMAN DYNAMIC ANTIRESONANT VIBRATION ISOLATOR (DAVI), USAAMRDL Technical Report 68-46, Eustis Directorate, U. S. Army Air Mobility Research and Development Laboratory, Fort Eustis, VA, December 1968, AD 687324.
- <sup>5</sup> Calcaterra and Schubert, ISOLATION OF HELICOPTER ROTOR-INDUCED VIBRATIONS USING ACTIVE ELEMENTS, USAAMRDL Technical Report 69-8, Eustis Directorate, U. S. Army Air Mobility Research and Development Laboratory, Fort Eustis, VA, June 1969, AD 859806.



In Reference 4, rotor isolation in all directions was shown to be analytically feasible for "statistical" helicopters ranging in weight from 2,000 to 100,000 pounds. Since the  $n$ -th harmonic or  $n/\text{rev}$  of an  $n$ -bladed rotor is the predominant excitation frequency, antiresonant isolation appeared to be an ideal solution to helicopter rotor isolation. Using a unique passive isolator, the Dynamic Antiresonant Vibration Isolator (DAVI), conceptual arrangements were studied for isolating the fuselages of various size helicopters from their rotor and transmission or from their rotor, transmission, and engine. The DAVI is based on inertial coupling. By the adjustment of a weighted lever, it can be tuned to provide an antiresonance at the predominant excitation frequency. That is, at its tuned frequency (the  $n/\text{rev}$ ), the force from the inertia bar cancels the spring force causing the isolated pivot (the transmission/fuselage attachment point) to be a node point, thereby providing virtually 100-percent isolation. Results indicated that a high isolation system stiffness was possible, thereby minimizing relative displacement and the attendant problems of engine drive coupling misalignment, undesirable control system inputs, and the potential loss of mechanical stability. Being passive, the DAVI didn't require external power or signal conditioning equipment. Furthermore, it was mechanically simple, could be small in size and in envelope requirements. Thus, it was potentially light in weight and amenable to isolation system/airframe integration.

Reference 5 presents the results of a study using a unidirectional active isolation system. In this study, an electrohydraulic isolator exhibiting narrow bandwidths of isolation at frequencies corresponding to the blade passage frequency and its second and third harmonics was used. Single rotor helicopters with gross weights of 2,000 pounds through 80,000 pounds and blade passage frequencies of 13.3 Hz through 26.6 Hz were considered. The system, being active, required external hydraulic and electrical power as well as electronic signal conditioning equipment. Based on some gross simplifying assumptions of the physical system, impressive vibration attenuation and displacement control were predicted with an associated high weight penalty (4-5 percent gross weight). The trend of these results shows that for the application of this isolator to configurations of lower blade-passage frequency than the 13.3 Hz studied, such as 10 Hz (typical of UH-1 and CH-47), both displacement and system weight would increase markedly. At 10 Hz blade passage frequency, relative displacement would double, and weight would increase to approximately 8 percent of gross weight. Also, the validity of this study was clouded by the simplifying assumptions. Chiefly, the isolator was interposed between the rotor and transmission and the rotor shaft was assumed to be capable of transmitting torque from the fuselage-mounted transmission to the rotor while allowing relative vertical displacement between the rotor and the fuselage. In addition, the analysis considered vertical excitation only. Due to these simplifying assumptions, together with the system's complexity and weight, USAAMRDL concluded that feasibility had not been established.



Upon completion of these feasibility studies, USAAMRDL sponsored two full-scale ground vibration tests to demonstrate the feasibility of isolation systems providing vertical and inplane rotor isolation. As with the feasibility studies, one effort was for an active system, the other for a passive system. The results of these feasibility demonstrations are reported in References 6 and 7.

In the experimental program of Reference 6, the DAVI, shown to be feasible in the earlier study, was tested. For this program, a 3-directional isolation system incorporating four DAVIs of a single size suitable for installation at the transmission/airframe interface in either a 6,500-lb or a 10,000-lb vehicle was designed. The DAVI spring elements provided torque restraint. Isolator parameters were not optimized for either gross weight or any rotor configuration. The test vehicle, a stripped UH-2 helicopter, was ballasted to 6,500 lb gross weight to simulate a UH-1 helicopter. The rotor and transmission were simulated by an upper body with proper weight and inertial characteristics. The free-flight condition was simulated by suspending the test vehicle from the rotor by a bungee and, in turn, suspending the fuselage from the upper body by the isolation system. Tests consisted of sequentially exciting the rotor hub with an electromechanical shaker in the vertical, lateral, and longitudinal directions. The levels of excitation were of sufficient magnitude to induce responses of approximately  $\pm 2g$  throughout the unisolated aircraft. The frequency of excitation was varied to represent a two-, three-, and four-bladed helicopter. Excellent isolation and displacement control were attained, confirming earlier predictions. Results were particularly good for the three- and four-bladed configurations. At their predominant excitation frequencies (3/rev and 4/rev), the average isolation for the two cases was 90% and 70% in the vertical and inplane directions, respectively. For the two-bladed case, average isolation was 58% in both the vertical and inplane directions. The two-bladed results were good considering the difficulty of affording isolation for this configuration. To appreciate the difficulty, consider the following: (1) the predominant rotor excitation frequency (2/rev) is approximately 10 Hz while the 1/rev is very close at 5 Hz; (2) in order to preclude the occurrence of ground resonance for articulated-rotor cases, the isolation's natural frequency must be above the 1/rev frequency; and (3) the predominant fuselage response modes are close to the 1/rev excitation frequency. Because of the very close proximity of these fuselage and rotor excitation frequencies, the introduction of an

<sup>6</sup> Jones, A FULL-SCALE EXPERIMENTAL FEASIBILITY STUDY OF HELICOPTER ROTOR ISOLATION USING THE DYNAMIC ANTIRESONANT VIBRATION ISOLATOR, USAAMRDL Technical Report 71-17, Eustis Directorate, U. S. Army Air Mobility Research and Development Laboratory, Fort Eustis, VA, June 1971, AD 729317.

<sup>7</sup> von Hardenberg and Saltanis, GROUND TEST EVALUATION OF THE SIKORSKY ACTIVE TRANSMISSION ISOLATION SYSTEM, USAAMRDL Technical Report 71-38, Eustis Directorate, U. S. Army Air Mobility Research and Development Laboratory, Fort Eustis, VA, September 1971, AD 736347.

isolation system natural frequency in their midst makes the two-bladed configuration most difficult to isolate. The greater difficulty of the two-bladed application is graphically illustrated by the following two figures. In Figure 1, the classical transmissibility-versus-frequency curve is shown for a DAVI tuned to provide an antiresonance at the 2/rev excitation frequency. Transmissibility is defined as the ratio of response ( $\pm g$ 's) at the isolated side of the DAVI to that at the non-isolated side of the DAVI. For the above cited reasons, the DAVI resonant frequency is shown placed above 1/rev.

In contrast, Figure 2 shows a transmissibility curve for a DAVI tuned to provide antiresonance at the 4/rev excitation frequency with the resonant frequency again placed above 1/rev. Clearly, the four-bladed case with the broader spread between 1/rev and blade-passage frequency is more amenable to antiresonant isolation. In the four-bladed application, this "broad spread" not only allows the DAVI resonance to be placed well above the 1/rev, thereby precluding ground resonance, but also permits greater latitude or design freedom in its placement, thus avoiding structural resonances of the predominant fuselage response modes. More importantly, because it is at a higher frequency, the four-bladed application is less sensitive to damping. Damping has the effect of lowering the response at the resonant peak and reducing the isolation provided at antiresonance or within the antiresonant "bucket". Because of this and the ability to place the DAVI resonance sufficiently far from the 4/rev excitation frequency, a better, broader bandwidth (wider antiresonant bucket) may be realized. Figure 3 graphically illustrates the profound effects discussed above of blade-passage frequency and damping on isolation. The inset relates the physical significance of the frequency ratio to isolation system resonance, antiresonance, and blade-passage frequency. Clearly, for the 2-bladed UH-1 configuration where the frequency ratio  $a/\Omega = 1.2$ , isolation is most sensitive to damping and dynamically most challenging. From these results, it was concluded that the feasibility of the DAVI concept had been demonstrated.

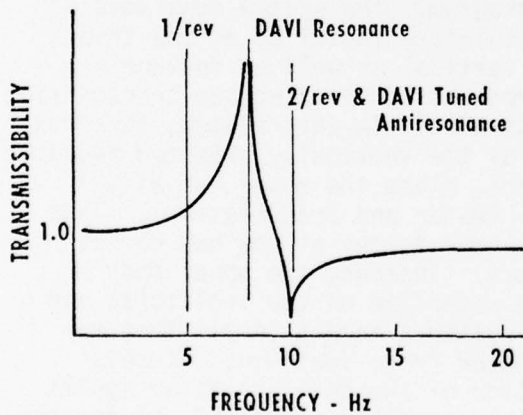

Figure 1. Two-Bladed Case

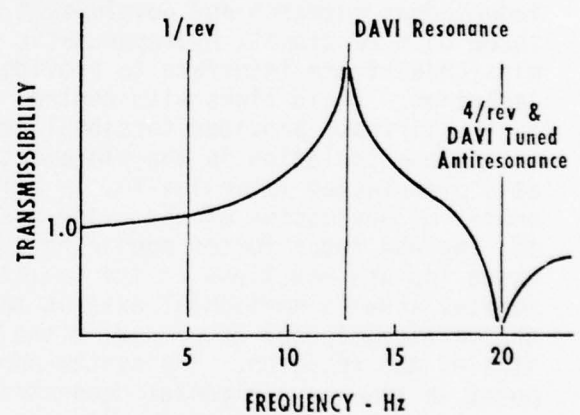

Figure 2. Four-Bladed Case

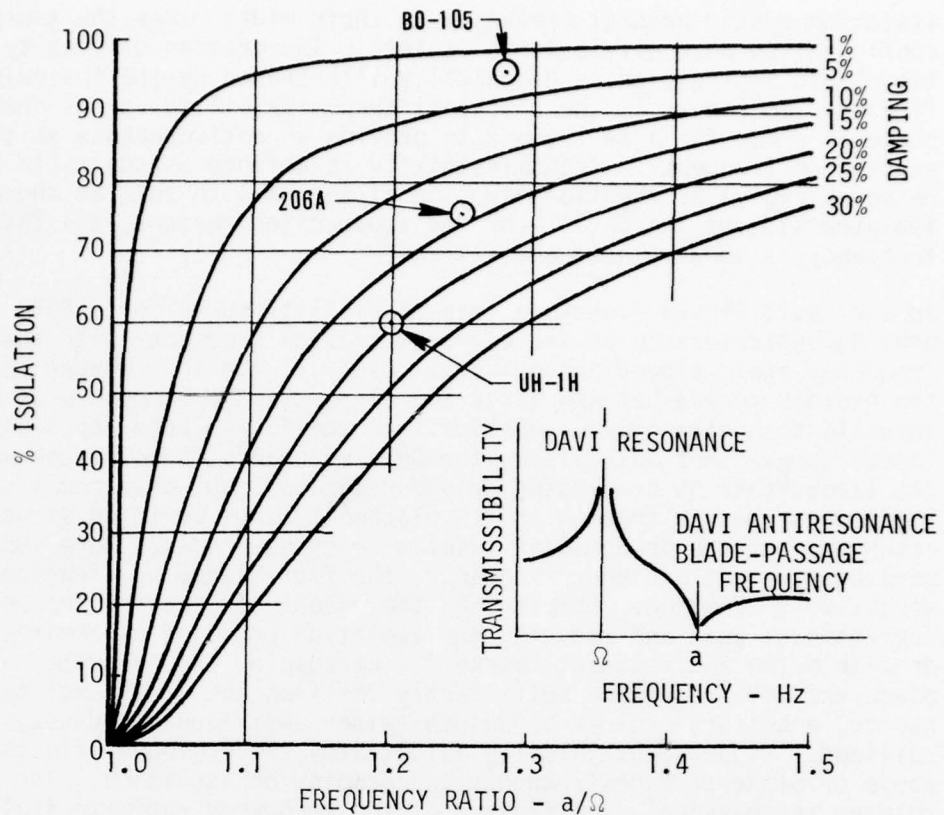

Figure 3. Isolation vs Frequency Ratio

The experimental results of an active isolation system on a six-bladed CH-53A helicopter are reported in Reference 7. Prior to USAAMRD's support of this demonstration, Sikorsky Aircraft Corporation conducted a feasibility study of helicopter rotor isolation under their corporate independent research and development program. The system consisted of three unidirectional, hydropneumatic isolators installed at the transmission/airframe interface to provide vertical as well as inplane isolation. Rigid links with control rod-ends connecting the transmission to the airframe provided torsional restraint. In this system, the crux of inplane isolation is the placement of the vertically oriented isolators at a preselected waterline to, in effect, place the rotor hub at the center of percussion of the upper body (rotor and transmission). That is, inplane rotor forces appearing as shear forces at the hub do not cause inplane reactions at the isolators. Instead, the upper body rotates about a horizontal axis at the waterline of the isolators, and the vertical forces developed in the isolators form a couple that restrains the rotation. The system appeared to be feasible. At this point in time, experimental demonstration of the DAVI isolation system was underway. Consequently, to keep the competition "alive", giving the



Army the opportunity to more fully assess the merits of both passive and active isolation systems before committing Army funds to a more costly flight test demonstration, an experimental demonstration of Sikorsky's active isolation system was initiated. The six-bladed, 35,000-lb CH-53A was selected as the test vehicle. Ground vibration testing was conducted in a manner similar to that described above for the DAVI. Excellent isolation and displacement control were attained, confirming earlier predictions. At the predominant excitation frequency (6/rev), average isolation in the vertical and inplane directions were 68% and 71%, respectively. The system had an almost negligible power penalty (16 horsepower) that could be operated as an integral part of the 3,000-psi onboard hydraulic system. However, the isolation system was very complex and heavy - too much so to warrant retrofitting any current Army helicopter. A production isolation system weighing 370 pounds (1.1% GW) was projected for the 35,000-lb CH-53. This was possible only through extensive airframe structure and transmission housing modifications. Feasibility appeared to be limited to new helicopter designs, where the necessary design freedom for isolator placement and weight savings could be realized. In terms of isolation, complexity, and weight, this system appears best suited, if not limited, to large, multi-bladed helicopters. This is because of the following two reasons: First, the performance of a helicopter rotor isolation system is directly related to the number of rotor blades. Generally speaking, the more blades a helicopter rotor has, the less difficult it is to achieve effective isolation. This, of course, is because of the "spread" between 1/rev and blade-passage frequency, discussed above. Second, isolation system weight as a percentage of gross weight varies inversely with helicopter gross weight. Thus, for any given isolation system concept and comparable design requirements, the maximum weight penalty will be for the lowest gross weight vehicle. In addition to these practical constraints of system performance, complexity, and weight, the anticipated flight performance remains clouded. Specifically, the "focusing" parameters used in the ground vibration test were selected to best isolate inplane vibratory rotor shear forces. However, for an articulated rotor, vibratory hub moments, although not quite as important, are also of some concern. Furthermore, the focusing requirements for inplane hub shears and moments are not compatible. To isolate both requires some form of compromise to achieve a best net effect. The ground vibration test included hub shears only. Thus, the isolation system's performance in the presence of both hub shears and moments is unknown.

After the completion of these demonstrations, USAAMRDL concluded that a passive isolation system, the DAVI, was the most promising. It not only performed well but would work on a broad range of helicopters, regardless of size or rotor type. Being mechanically simple, it was inherently reliable. Because it could be light in weight and small in size, it had

retrofit potential. Further, the DAVI concept had been well researched, and its development bore the least risk. For these reasons, USAAMRDL selected the DAVI to be flight test demonstrated. The UH-1H was selected to be the test vehicle. The reasons for USAAMRDL's selection follow:

(1) Availability - there were more UH-1 series helicopters in the Army inventory than any other type. Of these, the H model was the most recent.

(2) As noted above, UH-1 series helicopters employ an inplane isolation system. That is, they have the rotor and transmission mounted on elastomeric elements to minimize the transmission of inplane rotor-induced forces to the fuselage. The removal of this system would provide much of the space necessary for installing a new isolation system, thus requiring minimal structural modification and program cost.

(3) Rotor isolation is directed at one of the helicopter's most basic problems - vibration. The attenuation of vertical rotor-induced vibratory forces had remained elusive. For the UH-1 and AH-1 series helicopters, a rigid link connects the rotor and transmission to the fuselage. This link not only carries the static lift load but also transmits vertical vibratory forces directly from the rotor to the fuselage, causing fairly high vibration levels. Over the years, the gross weight of the UH-1 had grown from 6,600 to 9,500 lb, aggravating the situation. In 1967, the Bell Helicopter Company experimented with a servo-controlled hydraulic actuator (called an active lift link) to replace the rigid lift link. Flight test results were disappointing. Excellent isolation of 1/rev excitation was realized, but the isolation of the predominant 2/rev excitation met with only limited success. With these results, the Bell Helicopter Company's pursuits returned to techniques for arranging their passive isolators (called pylon focusing) to attenuate rotor-induced fuselage vibration. Only modest gains were realized over a protracted period of research. Thus, with retrofitting a possibility and the UH-1 experiencing a growing vibration deficiency when compared to Military Specifications, the choice of the UH-1H was well-founded.

(4) For the reasons discussed above, the two-bladed UH-1 represented, from the dynamic viewpoint, the most difficult case. Also, because of the UH-1's relatively low, 6,600-lb design gross weight, it presented a design challenge in terms of weight penalty.

Having selected a DAVI isolation system to be flight test demonstrated on a UH-1H helicopter, a six-phase program was planned. This program, documented in this report, consisted of the following:

PHASE 1 - Baseline flight vibration survey of the UH-1H demonstration vehicle.

PHASE 2 - Baseline ground vibration survey (shake test), including an assessment of the influence/effectiveness of the production inplane isolation system.



PHASE 3 - Isolation system design and analysis.

PHASE 4 - Fabrication of isolation system and aircraft modifications.

PHASE 5 - Confirmatory ground tests of modified vehicle including component tests, a 100-hour system endurance test, and a system proof test.

PHASE 6 - Flight test evaluation.

During the performance of the program reported on herein, two prime helicopter manufacturers, Bell Helicopter Company and Boeing Vertol, independently initiated and/or accelerated their research and development of rotor isolation systems. As stated above, isolation in the vertical direction is precluded by conventional means. Therefore, to achieve vertical isolation, both companies resorted to antiresonant systems that are intrinsically DAVI systems.

Bell Helicopter's approach has been to combine pylon focusing with antiresonant vibration isolators to achieve isolation in the inplane and vertical directions, respectively. The term "pylon" as used by Bell refers to the rotor and transmission. As previously stated in this program review, Bell Helicopter had been pursuing pylon focusing for many years, during which many kinematic arrangements were investigated. This work culminated in the development of a focused A-frame transmission mount for inplane isolation. In this arrangement, shown in Figure 4, the transmission is mounted by elastomeric bearings to two rigid A-frames longitudinally positioned along each side of the transmission. Each A-frame is "focused", strategically placing the pylon/A-frame mounting points so that the angular pitching response of the pylon is minimized and the inplane hub shears are reacted by a pair of vertically oriented couples at the base of each A-frame. Fuselage pitching moments due to inplane hub shear forces are offset or cancelled by opposing moments developed about the fuselage center of gravity by the pylon-restraint spring. This elastomeric spring (not shown in Figures) is installed beneath the transmission. The waterline location of the focal point, which is the pylon A-frame/mounting point, is a function of the stiffness of this spring, as well as the height of the A-frame. Vertical hub forces are transmitted directly through the A-frames to the nodal beams. Transmission torque is restrained by a pair of links connecting the lower transmission to the fuselage. Suitable rod-end type bearings are employed, allowing freedom of vertical motion without affecting nodalization. Figures 4 and 5 schematically illustrate how two nodal beam configurations respond to vertical excitation.

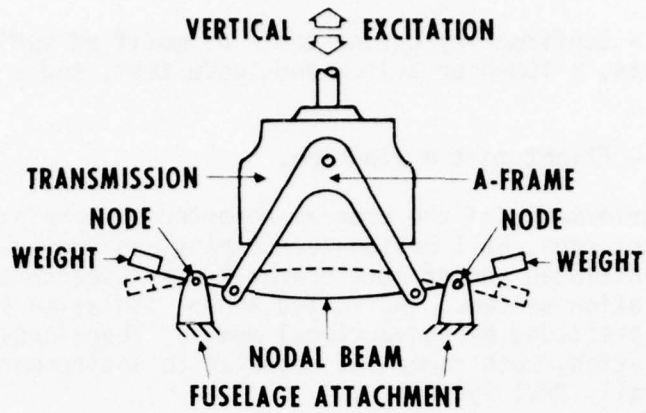

Figure 4. Early Version of Bell's Focused Pylon/Nodal Beam Isolation System

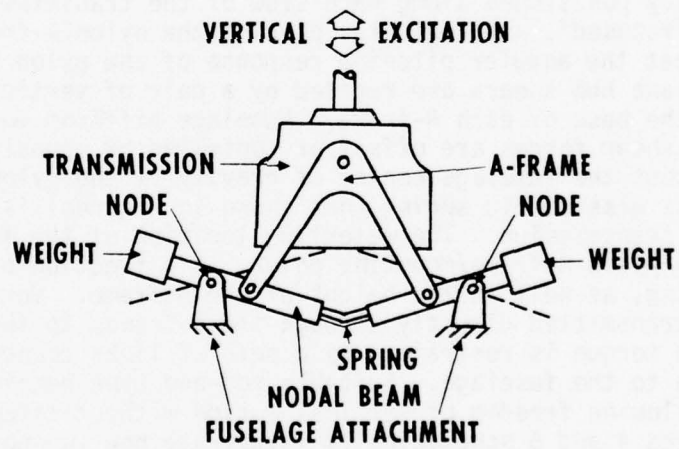

Figure 5. Recent Version of Bell's Focused Pylon/Nodal Beam Isolation System

As shown in these figures, each A-frame is mounted to a nodal beam to which the fuselage is also attached. These nodal beam attachments initially utilized dry-lubricated, TEFLON-type bearings, although more recently elastomeric bearings have also been employed. "Nodalizing" weights, secured to the ends of each nodal beam, "tune" the beam, causing each nodal beam/fuselage attachment point to be an antiresonance or node. Figure 4 is a schematic of Bell's earlier work on the Model 206A Jet Ranger, wherein the flexural elasticity of the beam served as the spring element. In subsequent developments, the "flexible" nodal beam has given way to a more rigid nodal beam with a discrete spring at its mid span. Figure 5 is a schematic of this latter development.

Bell Helicopter's results on the Jet Ranger were outstanding. These results, taken from Reference 8 and shown in Figure 6, show a very low,  $\pm .05 - .07g$  response throughout the speed range for 1.0g level flight. Although it is not shown in this figure, the standard Jet Ranger does have the classical roughness normally associated with low-speed transitional flight. This roughness has been eliminated by the isolation system's nodal beam.

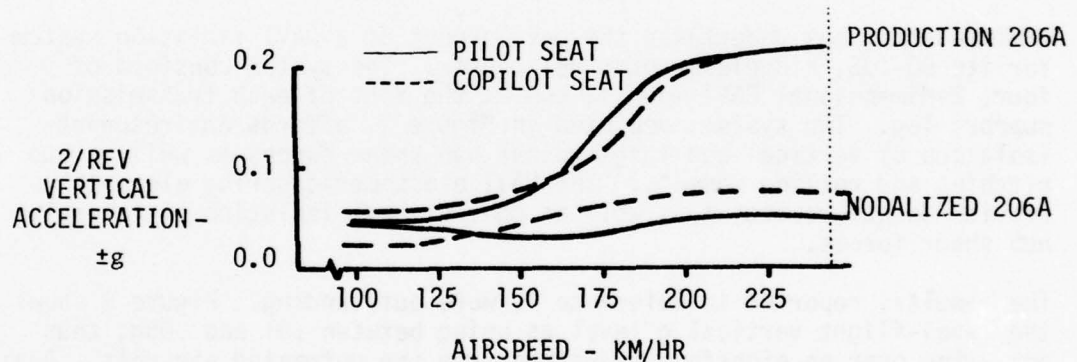

Figure 6. Jet Ranger Flight Test Results

<sup>8</sup> Shipman, NODALIZATION APPLIED TO HELICOPTERS, Society of Automotive Engineers Paper Number 730893, Presented at National Aerospace Engineering and Manufacturing Meeting, Los Angeles, California, October 1973.

Nodal isolation systems, basically as illustrated in Figure 5, are in production on two models: the 214/A/B/C Tactical Transport and the 206L Long Ranger. Similar systems are under development for the YAH-63 Advanced Attack Helicopter and the Model 222 commercial light twin helicopter.

Pylon focusing, it should be noted, cannot be simultaneously achieved for the isolation of both inplane hub forces and hub moments. The requirements for each are incompatible. Bell Helicopter's focused pylon systems are for the isolation of inplane shear forces, since their rotor systems are teetered and hub moments are not developed. However, for "rigid-" and articulated-rotor systems, vibratory hub moments, as well as inplane shears, are of concern. If focusing is attempted for such a system, some trade-off or compromise between inplane and moment focusing would appear to be necessary to achieve the best results. To enhance handling qualities, control power, and pilot workload for teetered-rotor systems to be used in nap-of-the-earth maneuvers necessary for observation and attack missions, Bell Helicopter has done developmental work with the high energy rotor and flapping-moment hub-springs. Because of the hub-spring, these teetered-rotor systems "fall" into the "rigid-" and articulated-rotor category for pylon focusing purposes. Consequently, the development of an effective pylon focusing system for these vehicles that performs as well as ones for comparably sized teetered-rotor systems may prove to be very difficult.

Boeing-Vertol has undertaken the development of a DAVI isolation system for its BO-105, hingeless-rotor helicopter. The system consists of four, 2-dimensional DAVI mounts, one at the foot of each transmission support leg. The system, depicted in Figure 7, affords antiresonant isolation of vertical and longitudinal hub shear forces as well as hub pitching and rolling moments. The DAVI elastomeric spring elements provide torque restraint as well as conventional isolation of lateral hub shear forces.

The results, reported in Reference 9, were outstanding. Figure 8 shows the level-flight vertical g level as being between .01 and .05g, thus achieving over an eightfold reduction from the untreated aircraft. Again, as with Kaman and Bell, the roughness associated with transitional flight has been eliminated. The vibration levels during a normal approach and landing flare were also significantly reduced, by a factor of ten.

---

<sup>9</sup> Ellis, Diamond and Fay, DESIGN DEVELOPMENT AND TESTING OF THE BOEING VERTOL/YUH-61A, American Helicopter Society Paper Number 1010, Presented at 32nd National Annual Forum, Washington, D.C., May 1976.



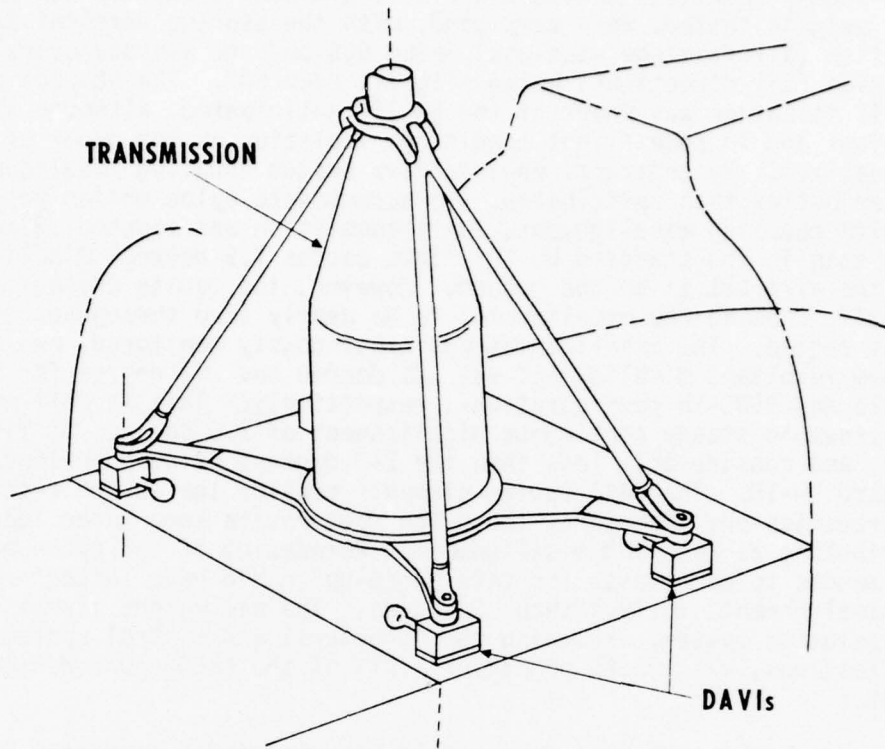

Figure 7. B0-105 Isolation System

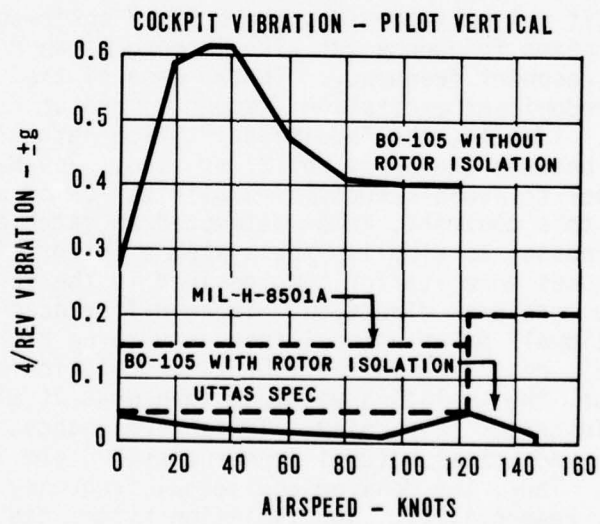

Figure 8. B0-105 Vibration Levels



Kaman's UH-1 results, considering all flight conditions for the two gross weights tested, were very good, with the average vertical 2/rev isolation (all fuselage stations) being 60% and the average overall isolation (all directions) being slightly over 50%. The 50-plus percent overall isolation was short of the 60-75% anticipated, although at some locations and in some flight conditions isolation on the order of 75-80% was realized. By contrast, engine/drive system coupling misalignment was far better than anticipated. To accommodate pylon motion yet minimize coupling misalignment, the transmission was mounted .3 inch lower than in the standard UH-1H. This causes 1.9 degrees misalignment when the aircraft is on the ground. However, the mounts deflect after lift-off, causing the misalignment to be nearly zero throughout the 1.0g flight regime. The misalignment was continuously monitored, and the maximum resultant misalignment was .81 degree and .97 degree for the 8250-lb and 9500-lb configurations, respectively. This is well within the allowable steady continuous misalignment of 2.0 degrees at 1100 horsepower, and considerably less than the 2-3 degrees being experienced in the standard UH-1H. The DAVI spring elements provide the torque restraint of the transmission; therefore, the pylon does rotate some under load, contributing to coupling misalignment. Reindexing of the pylon on the DAVI mounts to compensate for this "wrap-up" could have further reduced the misalignment, to less than .5 degree. The net weight increase for the isolation system, excluding the structural and control system modifications, was 125.85 pounds or 1.91% of the 6600-pound design gross weight.

In assessing these results, one should bear in mind that system optimization was never attempted. Some comments as to why the isolation results were not as good as anticipated and how these results could be improved, follow. A concern with any antiresonant rotor isolation system such as the DAVI is that it not only provides the desired antiresonance at the predominant excitation frequency but also introduces an "additional" pylon natural or resonant frequency. In the case of the UH-1, the 1/rev and the 2/rev (predominant excitation frequency) are at 5.4 Hz and 10.8 Hz, respectively. Ideally, the "additional" pylon natural frequency should be midway between the 1/rev and 2/rev (i.e., 7.9 Hz) - sufficiently removed from either to avoid structural amplification of any dynamic response. Under this contract, Kaman attempted to match existing UH-1H pylon-mount stiffnesses to simplify the system's integration task. The resultant stiffnesses were stiffer than desired in the vertical direction and softer in the torsional direction. These differences in stiffness caused the "additional" pylon natural frequency to be higher than desired (9.0 Hz vs 7.9 Hz), resulting in the vibration isolation provided. So, although very good, the isolation was less than what it might have been. Figure 3 best illustrates this point. The antiresonance,  $a$ , is 10.8 Hz, while the desired and actual natural frequencies,  $\Omega$ , are 7.9 Hz and 9.0 Hz, respectively. Thus, the desired and actual frequency ratios,  $a/\Omega$ , are 1.37 and 1.2, respectively. The isolation system has about 20% damping. At the respective frequency ratios for this amount of damping, it is seen in Figure 3 that nearly 80% isolation could have been

realized - significantly better than the approximately 60% actual. Eliminating the lift-link DAVI and incorporating a portion of its spring rate into the four remaining transmission-mount DAVIs should sufficiently alter the pylon stiffness and the "additional" natural frequency to significantly improve rotor isolation. An optimized four-point mounting system has a projected weight of 84.0 pounds, or 1.27% of the design gross weight.

In comparing Bell's results with Kaman's, one should do so while keeping in mind that these organizations conducted their developmental work under different circumstances and design constraints. Bell was optimizing a production system, whereas Kaman was demonstrating system feasibility. As for design constraints, Bell's Model 206A has a long engine-transmission drive shaft which, together with the low 2900-pound GW, is relatively insensitive to coupling misalignment. Thus, they could concentrate on isolation performance and be relatively free of deflection and misalignment worries. In contrast, the UH-1 has a short drive shaft for which coupling alignment is more sensitive to displacement. This and the fact that Kaman designed for operation at 9500-pound gross weight compounded their design challenge. Kaman placed primary emphasis on maintaining the UH-1H's dynamic characteristics to preclude, with minimal effort, the occurrence of dynamic problems, thereby simplifying the system's integration task. In so doing, Kaman somewhat inadvertently achieved exceptionally low coupling misalignment. The somewhat higher than desired pylon-mount stiffness, cited above, contributed to this low misalignment. Nonetheless, using hindsight, it is apparent that even the target pylon-mount stiffness could have been lower, yielding significantly better isolation while maintaining acceptable coupling misalignment.

Although there are presently no USAAMRDL plans regarding further rotor isolation work, investigations of multi-frequency antiresonant isolation concepts, pylon focusing techniques, and low damping elastomers specifically for low isolation systems are recognized as warranting consideration. Retrofitting Army UH-1Hs with an optimized DAVI isolation system is outside the purview of the USAAMRDL. Such a decision must trade-off the cost of retrofitting against the performance, comfort, reliability and maintainability benefits. A cursory estimate of the R&M benefits in terms of 1975 dollars is presented in this report. This estimate is predicated on a premise that is supported by the findings of Reference 10 that vibration-induced failures will be reduced in proportion to the vibration reduction afforded by the DAVI isolation system. Reference 10, incidently, was a study of Sikorsky S-61 (Air Force H-3) helicopter squadrons with and without the Sikorsky-developed Bifilar Absorber. The results in themselves may not constitute a precise measure of the effect of vibration on R&M. However, San Francisco Oakland Airways, a

<sup>10</sup> Veca, VIBRATION EFFECTS ON HELICOPTER RELIABILITY AND MAINTAINABILITY, Sikorsky Aircraft; USAAMRDL Technical Report 73-11, U. S. Army Air Mobility Research & Development Laboratory, Fort Eustis, Virginia, April 1973, AD 766307.

commercial carrier with many thousands of hours utilizing S-61's equipped with Bifilar Absorbers, reports similar results, lending credence to the premise. Returning to Kaman's R&M analyses, this estimate projects 52 to 67% reductions in the vibration-induced failure rates of fifteen sub-systems. A resultant 31.3% reduction in the total failure rate is estimated. This, in turn, corresponds to a projected total labor and repair parts savings of \$50.26 per flight-hour. According to Reference 11, the Army has 3208 UH-1H helicopters, of which 80.11% are actively deployed at a current utilization rate of 20 flight-hours per month. Assuming that 1000 aircraft were to be retrofitted, thereby achieving the benefit of the lower costs associated with volume production, the total cost of retrofitting is estimated to be approximately \$7,000,000. This is based on an estimated cost of about \$5,000 to modify each vehicle (\$5,000,000), in addition to a \$2,000,000 non-recurring developmental cost to optimize the envisioned DAVI system. In contrast, the annual savings would be \$12,000,000. Of this savings, \$9,600,000 could be realized from the reduced need for replacement parts; the remaining \$2,400,000 savings could be realized from the associated reduction in maintenance labor. This trade-off of R&M benefits versus retrofit costs might be summarized by saying that the entire cost to retrofit 1000 UH-1Hs could be recouped in the first seven months of operation. Based on these findings, the USAAMRDL recommends that the Army develop and implement a plan to retrofit its UH-1H fleet.

Undoubtedly, antiresonant isolation systems, whether called DAVIs, Nodal Beams or by some other label, have considerable potential for helicopter rotor isolation. The above-cited efforts, at Bell Helicopter and Boeing Vertol, attest to this. In fact, their vigorous efforts have brought antiresonant rotor isolation to fruition much sooner than could have been envisioned at the outset of this ten-year program, and certainly much sooner than if all the work had been conducted *under Army sponsorship*. Development of such isolation systems, including multi-frequency and multi-directional features, for future military and commercial helicopters is foreseen. Having sponsored the early research, "planting the seed" from which these concepts emerged, the USAAMRDL can view these recent developments with a sense of accomplishment. The initial goal of demonstrating the feasibility of isolating rotor-induced excitation in the vertical direction was not only accomplished, but a transfer of technology that increased the state of the art also took place, and this technology has already found its way into production systems.

---

<sup>11</sup> EXECUTIVE SUMMARY REPORT - UH-1H ASSESSMENT AND COMPARATIVE FLEET EVALUATION, USAAVSCOM Technical Report 75-3, U. S. Army Aviation Systems Command, St. Louis, Missouri, April 1975.



## DESIGN PHILOSOPHY

The ideal isolation system should isolate the fuselage from the major rotor induced n/rev excitations for all six rigid body modes of motion, which are:

1. First mode of pitch and longitudinal translation
2. Second mode of pitch and longitudinal translation
3. First mode of roll and lateral translation
4. Second mode of roll and lateral translation
5. Vertical translation
6. Yaw

This can be accomplished with a conventional passive isolation system by using a very soft spring rate. However, in the design of an isolation system, the following major problems must be considered:

1. Excessive Deflection
  - a. Drive system coupling problems
  - b. Flying quality problems
2. Mechanical Instability and Flywheel Resonance
3. Rotor, Transmission, Engine Torsional Instability

Depending upon the type of rotor system used, the priority of the above three problem areas may differ. However, excessive deflection is common to all. For example, the UH-1, a two-bladed helicopter, has a predominant excitation frequency at 10.8 Hertz. To obtain vertical isolation at the 2/rev frequency and no amplification at 1/rev requires that a conventional isolation system have a static deflection of approximately 0.7 inch, which will give excessive deflection during maneuvers.

Mechanical instability is a coupling between the inplane blade motions and the inplane hub motions of the isolation system and/or of the helicopter on its landing gear. The center of mechanical instability, which is the point at which the instability is most critical, is given by the following relationship:

$$\omega_n + \omega_B = \omega_{M.I.} \quad (1)$$



in which

$\omega_n$  = inplane natural frequencies of the isolation system  
and/or of the helicopter on its landing gear

$\omega_B$  = inplane blade natural frequencies

$\omega_{M.I.}$  = rotor speed for center of mechanical instability

For semirigid rotor systems used on UH-1 helicopters, in which the inplane natural frequencies of the blade are above one-per-rev of the rotor speed, mechanical instability is not a problem. For fully articulated rotor systems, in which the natural frequency of the rigid mode of the blade due to lag-hinge offset is well below one-per-rev, either the isolation system must be designed to have natural frequencies above one-per-rev or damping must be used to control the instability.

For two-bladed helicopters, flywheel resonance can be a problem in that there is an unstable range associated with this phenomenon. Therefore, care must be taken in the design of the isolation system not only to prevent amplification at one-per-rev, but also to insure that there is no flywheel instability in the operating range of the rotor.

Also, the problem of rotor/engine torsional instability differs with the type of rotor system. This instability is a function of the torsional stiffness, the inplane damping of the rotor system and the engine fuel control. Although a fully articulated rotor system has a very low natural frequency in torsion due to the lag motion of the blades, it also has mechanical lag dampers in the system, which add stability. Therefore, control of this instability does not usually require a complex engine fuel-control system.

The semirigid or hingeless rotor system blades have very high inplane natural frequencies, but the system does not have mechanical lag dampers. However, the UH-1 has a long rotor driveshaft and, therefore, has a relatively soft spring rate in torsion. This, then, requires a very stiff isolation system in yaw to compensate for the shaft torsional spring rate. This type of rotor system usually requires a more complex engine fuel control system to provide stability to achieve rotor/engine compatibility.

In approaching the task of modifying an existing, successful helicopter in which the dynamic characteristics are well known, it is best to have similar characteristics wherever possible in the modification. Therefore, two basic dynamic ground rules should be followed:

1. The isolated system should be designed to have the same mechanical instability and flywheel resonance characteristics as the unisolated system.

2. The torsional restraint of the isolation system should be designed to have characteristics similar to those of the non-isolated system to insure rotor and engine torsional compatibility.

## DESCRIPTION OF ISOLATION SYSTEMS

The UH-1H helicopter, Serial No. 66-1093, used in this program is shown in Figure 9. This helicopter utilizes a single, two-bladed, semirigid teetering, main rotor having a diameter of 48 feet and a 100-percent main-rotor speed of 324 rpm.

### STANDARD UH-1H ISOLATION SYSTEM

The standard UH-1H rotor isolation system, shown schematically in Figure 10, is designed to be structurally rigid in the vertical direction, to be soft inplane to obtain two-per-rev isolation, and to have a flywheel resonance well below the rotor operating range of the helicopter. It is relatively stiff in the yaw mode for satisfactory rotor/engine stability.

It is a five-point mounting system designed to isolate the fuselage from the inplane two-per-rev vibratory forces of the main rotor. To achieve this isolation, each of the five tubular elastomeric mounts, four of which are located at the corners of the transmission and the fifth located on the aft section of the transmission at Butt Line 0, has a low vertical spring rate to give a low natural frequency in pitch and roll. Each of the four transmission mounts has a high spring rate in the in-plane direction to react torque and to insure engine and rotor torsional compatibility. The fifth mount is pinned so that it does not react torque. The UH-1H has a rigid lift link to react the vertical load; therefore, no vertical isolation is achieved.

### UH-1H DAVI ISOLATION SYSTEM

In order to insure minimum structural modification and the integrity of similar load paths in the DAVI-modified UH-1H helicopter, the DAVI isolators were located at the same mounting points as in the standard system. Figure 11 shows a schematic of the DAVI system. In comparing the DAVI system with the standard system, it is seen that:

- (1) The standard four transmission mounts have been replaced with four two-dimensional DAVI mounts.
- (2) The standard fifth mount has been eliminated.
- (3) The standard lift link has been replaced by a unidirectional DAVI.

Thus, in this DAVI system, antiresonant isolation is obtained in the vertical, longitudinal, and pitching directions; conventional isolation is obtained in the lateral direction; and a combination of conventional and antiresonant isolation is obtained in the rolling direction.



Figure 9. UH-1H Helicopter Serial Number 66-1093



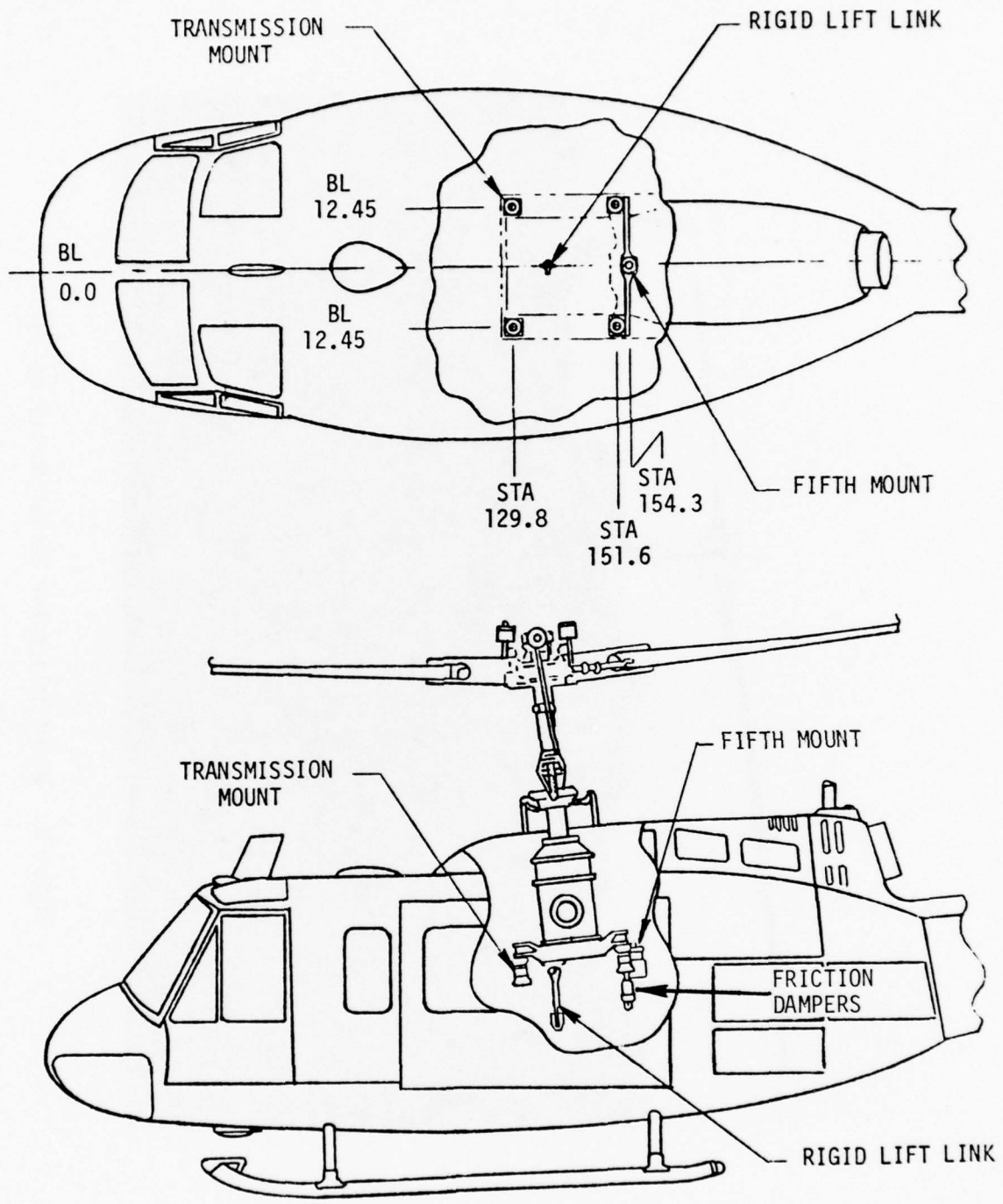

Figure 10. Schematic of the Standard UH-1H Isolation System

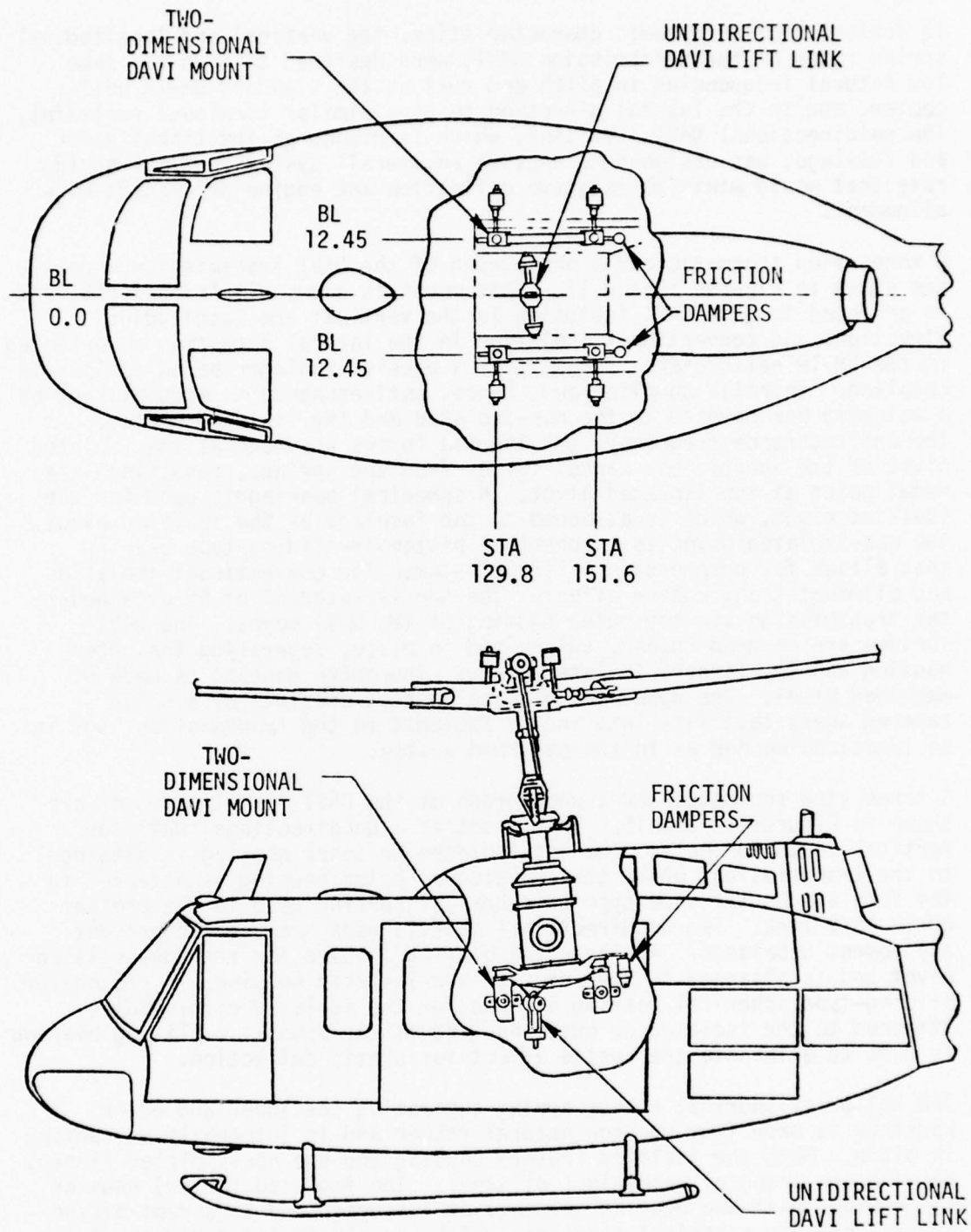

Figure 11. Schematic of the UH-1H DAVI Isolation System

To achieve similar dynamic characteristics, the vertical and longitudinal spring rates of the transmission DAVIs were designed to give the same low natural frequencies in pitch and roll as the standard UH-1H helicopter, and in the lateral direction to give similar torsional restraint. The unidirectional DAVI lift link, which is pinned at the transmission and fuselage, was designed to provide an overall system vertical spring rate that would minimize relative deflection and engine driveshaft misalignment.

A three-view schematic and a photograph of the DAVI transmission mount are shown in Figures 12 and 13. This mount is a two-dimensional DAVI and is oriented to give DAVI isolation in the vertical and longitudinal directions and conventional isolation in the lateral direction as oriented in the UH-1H helicopter. The DAVI is a passive isolator based on inertia coupling. Inertial coupling and, hence, antiresonance is accomplished by a weighted bar pivoted to the non-isolated and the isolated bodies. At the antiresonance frequency, the inertia forces produced at the isolated pivot of the inertia bar cancel forces from the springs, resulting in a nodal point at the isolated pivot. A spherical bearing is used for the isolated pivot, which is attached to the fuselage by the isolated pivot. The non-isolated pivot is a spherical piston or sliding-type bearing that allows for compression of the elastomer for conventional isolation and eliminates any cosine effect. The non-isolated pivot is attached to the transmission via the outer housing of the DAVI mount. The DAVI springs are uncured rubber, vulcanized in place, separating the outer housing and the (inner) isolated plate. The outer housing is made of machined steel. The upper end of each housing consists of a solid tapered shaft that fits into and is fastened to the transmission lugs in an identical manner as in the standard system.

A three-view schematic and a photograph of the DAVI lift-link mount are shown in Figures 14 and 15. This mount is a unidirectional DAVI for vertical isolation only. The non-isolated or inner housing is attached to the transmission, while the isolated or outer housing is attached to the fuselage by the same type of spherical bearing used in the present UH-1H lift link. Two unidirectional inertia bars are used to prevent any moment unbalance. A hinge-type bearing is used for the non-isolated pivot and is attached to the inner or non-isolated housing. A piston- or sliding-type spherical bearing is used for the isolated pivot and is attached to the isolated or outer housing of the mount. A sliding bearing is used to eliminate the cosine effect for static deflection.

The hollow cylindrical rubber spring separating the inner and outer housings is made from uncured natural rubber and is integrally vulcanized in place. Both the isolated (outer) housing and the non-isolated (inner) housing are integral machinings of steel. The isolated (outer) housing is provided with two bearing housings at its upper end to accept piston- or sliding-type spherical bearings, which are the isolated pivots of the DAVI. An integral flange at its lower end is used to bolt on a cap, which is essentially a lug fitted with a self-aligning (spherical) bearing (the same type used in the present UH-1 lift link) that fastens

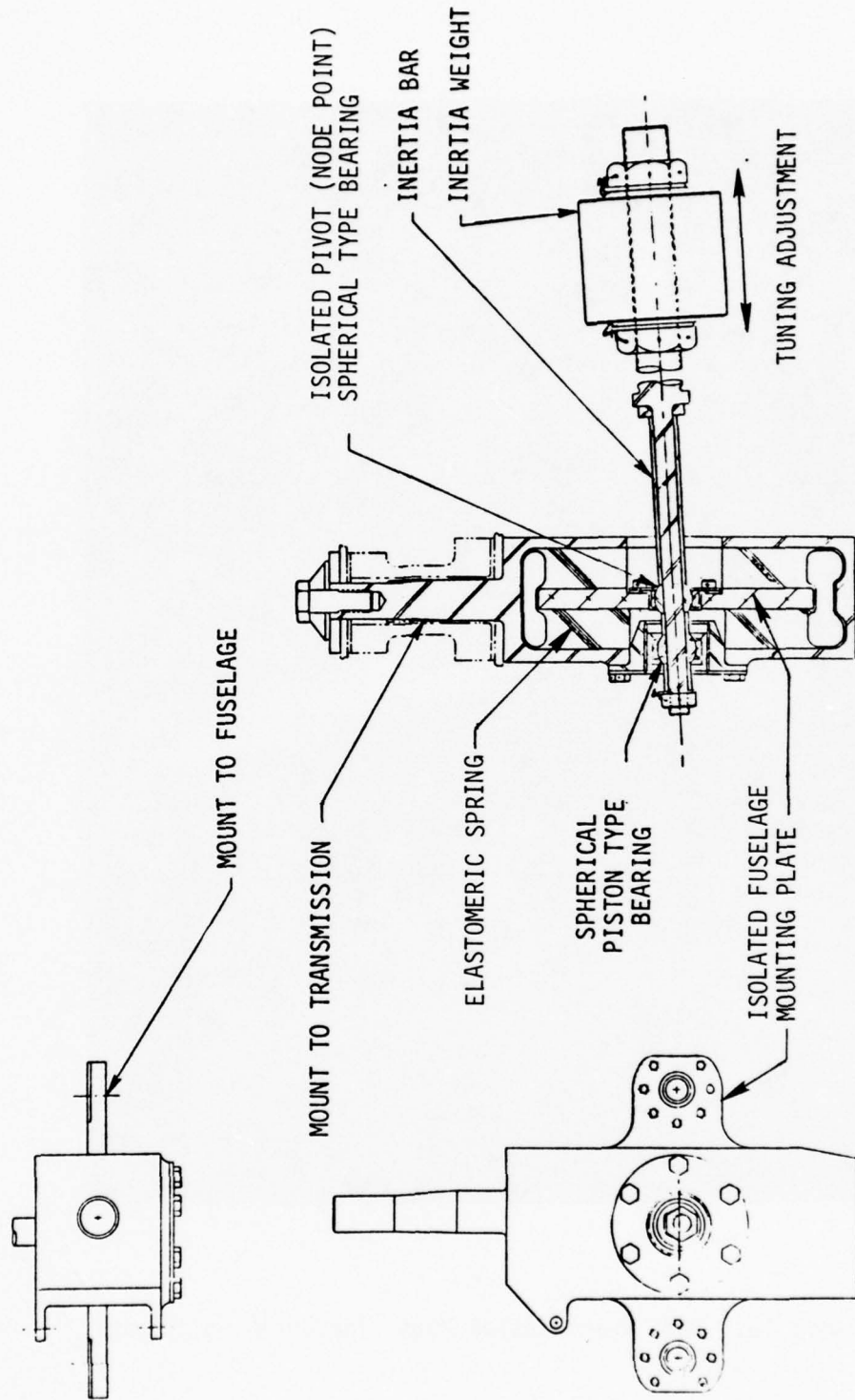

Figure 12. Transmission-Mount DAVI



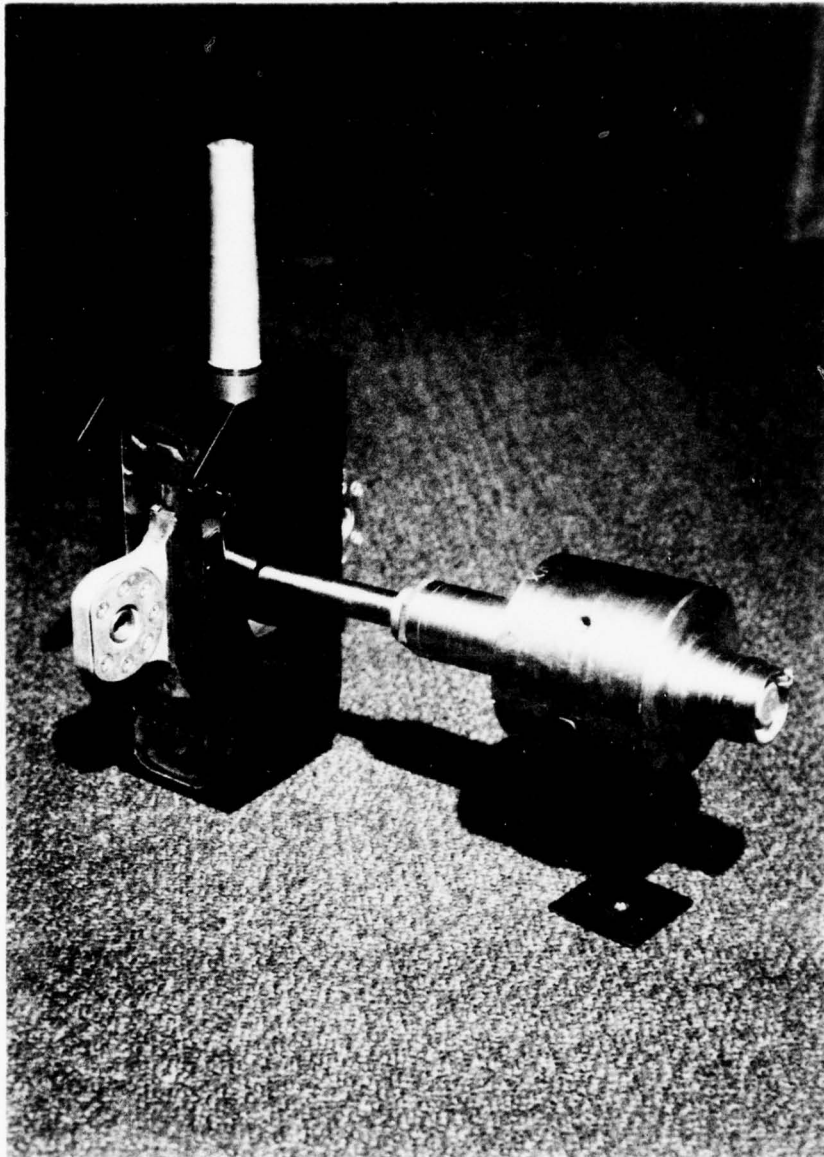

Figure 13. DAVI Transmission Mount for UH-1H Helicopter

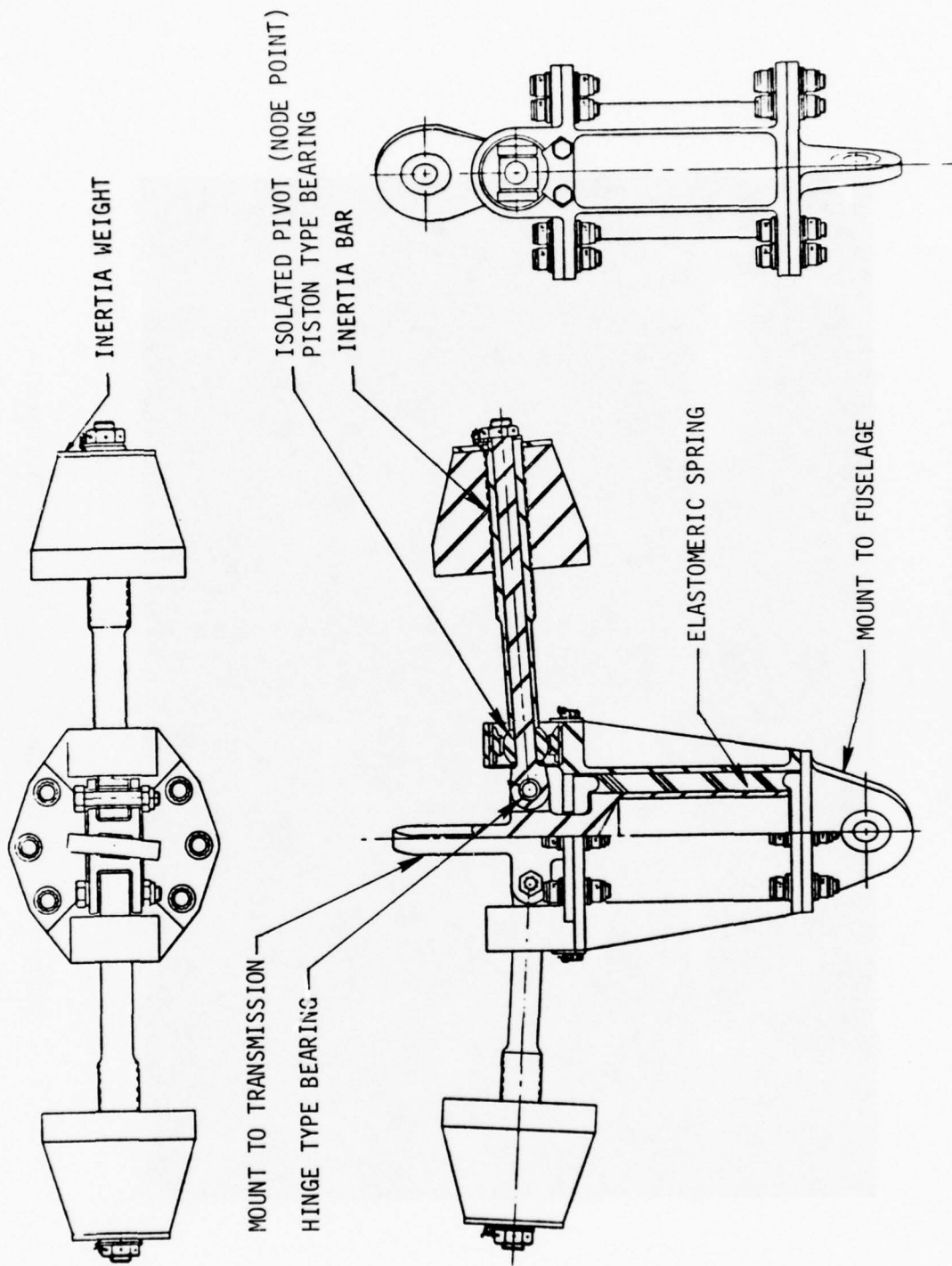

Figure 14. Lift-Link DAVI

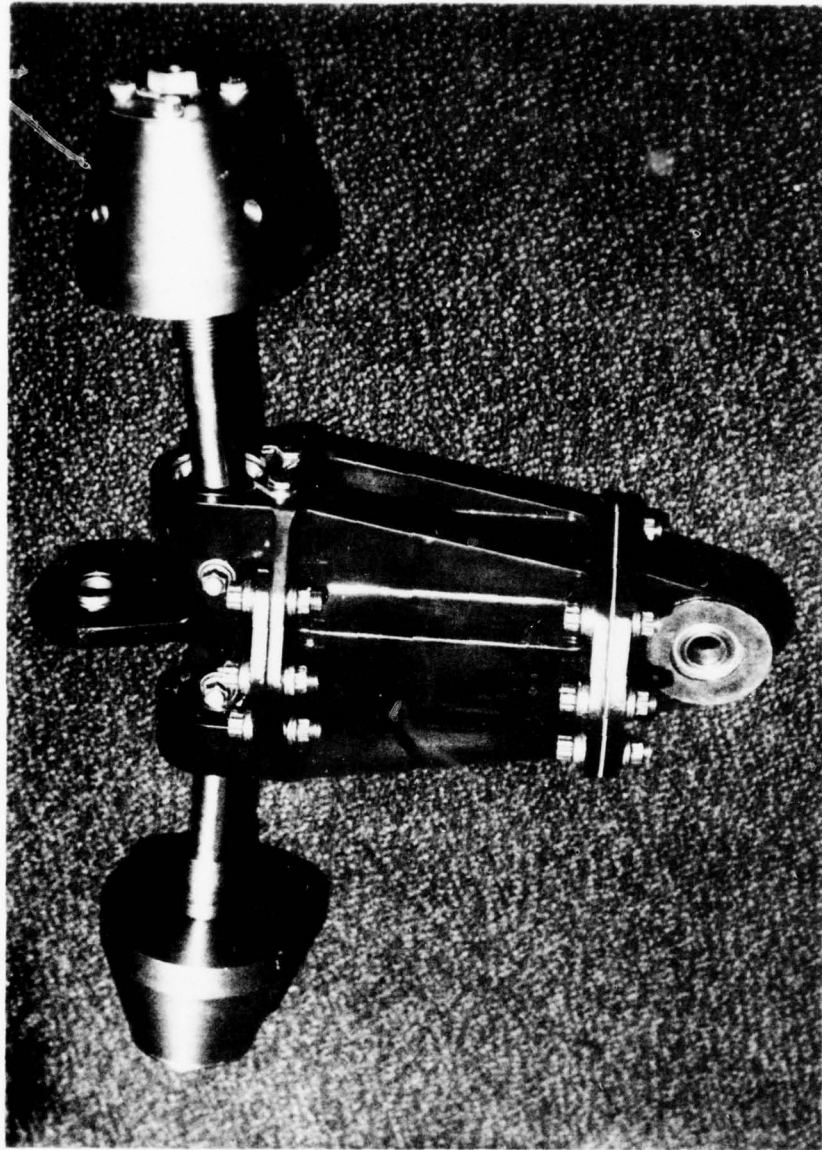

Figure 15. Photograph of the Lift-Link DAVI Mount

to the airframe lift beam. The non-isolated (inner) housing has two integrally-machined clevises that accept the inboard ends of the inertia bars, thus providing the non-isolated pivots for the DAVI. At its uppermost end is an integral lug that is fitted with a self-aligning, spherical bearing, which is the same type used in the present UH-1H lift link, and is fastened to the lugs at the bottom of the transmission case.

The tuning of the DAVIs was accomplished by positioning the movable inertia weight to give an antiresonance of 10.8 Hertz, which is the predominant excitation frequency of the UH-1H helicopter.

#### STRUCTURAL MODIFICATION

The DAVI isolation system is softer in the vertical direction than the standard system; thus, the DAVI system allows greater static vertical movement of the transmission with respect to the fuselage than the standard vehicle. In order to compensate for this static motion and to insure engine driveshaft alignment, the transmission installation was lowered 0.3 inch relative to the (fuselage) transmission carry-through structure. In addition, the transmission carry-through structure had to be lowered with respect to the underside of the transmission to maintain the original clearance. This lowering of the transmission is illustrated in the schematic of the engine-transmission installation shown in Figure 16. It is seen from this schematic that, for the unloaded system, the engine-transmission-driveshaft is misaligned 1.9 degrees with respect to the standard system, and as load (rotor thrust) is applied, the angular misalignment approaches zero. Similarly, both the standard and the DAVI-modified UH-1H isolation systems are statically misaligned -.47 degree in the lateral direction, which approaches zero under torque.

#### CONTROL SYSTEM MODIFICATION

The cyclic and collective control systems were modified to compensate for the larger relative deflection obtained in the DAVI system as compared to the standard system. This modification included compensating rods, idlers, and idler support fittings. The two cyclic boost actuators have been relocated to a welded steel beam that straddles the forward transmission lugs, while the collective boost actuator has been relocated to a welded steel beam that straddles the aft transmission lugs. Since the actuators are mounted on the transmission housing, they take advantage of the isolation features of the DAVI mounts, unlike the original design which transmitted the vibratory actuator loads directly to fixed airframe structures.



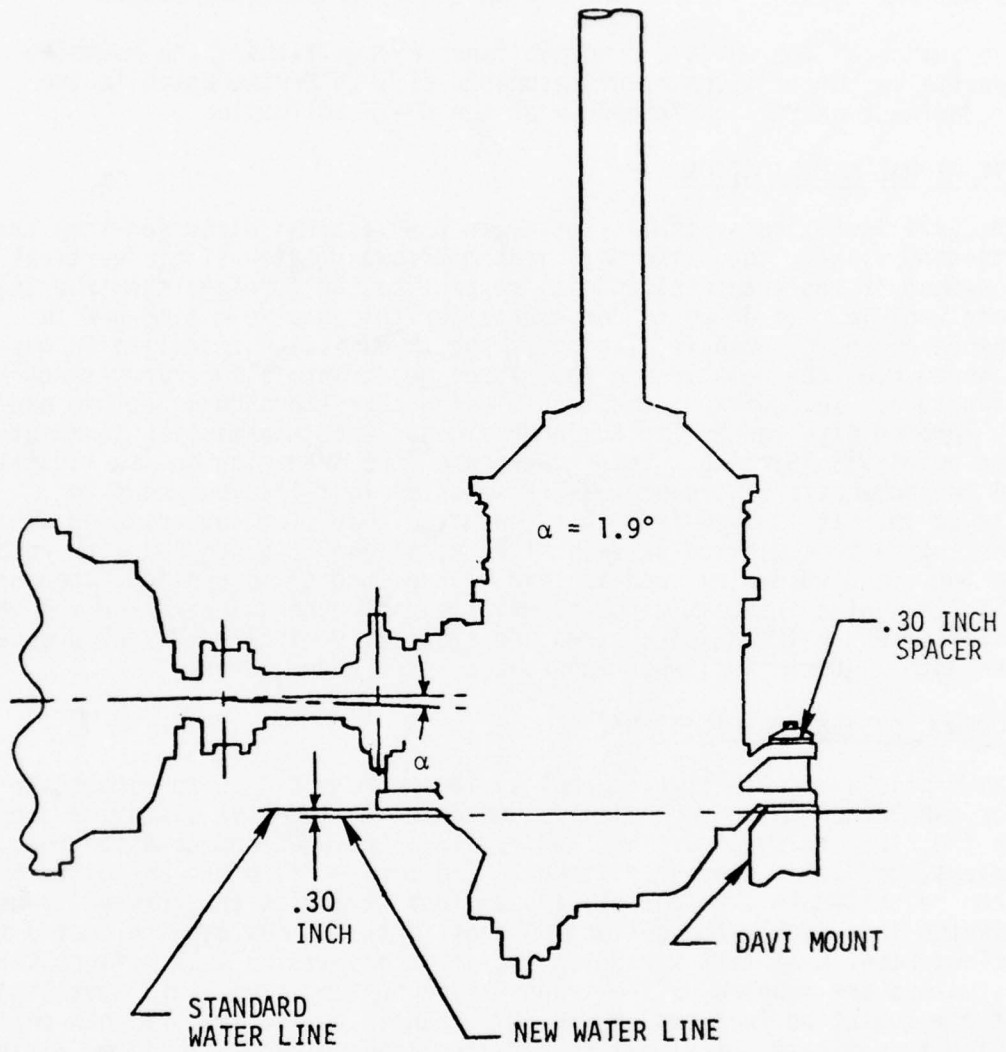

Figure 16. Schematic of Engine-Transmission Installation

## SYSTEM DEVELOPMENT SUMMARY

In order to insure safety, detailed analyses and component and system testing were conducted to substantiate the DAVI-isolated vehicle for flight. Details of these analyses and tests are provided in Volume II of this report.

### STRUCTURAL ANALYSES

The same critical flight, landing, and crash conditions used for design of the UH-1H helicopter were used for the modified UH-1H. In addition, a high gross weight, steady-state 45° banked turn condition was included. The loads applied to the four transmission DAVIs and the lift link DAVI were then calculated, taking into account the new geometry, mounting arrangement, spring rates, motions, etc. The static load distribution throughout the carry-through structure was then determined, and this structure together with the transmission mount and lift-link DAVIs were stress analyzed. In addition, a fatigue analysis for the DAVI mounts was conducted for two critical vibratory (flight) conditions.

The same critical jam load conditions used for the UH-1H helicopter were used for the modified control system, and in addition, loads in the added linkages and parts (idlers, compensating rods, supports, etc) were calculated. A detailed static stress analysis was then conducted for the cyclic and collective control beams mounted on the transmission, the collective compensating rod support (mounted on the underside of the transmission), the cyclic and collective idlers, the idler supports, the support beam and attachments, and finally, the new and revised control rods.

All analyses for both the DAVI-modified and the standard UH-1Hs were conducted for the design gross weight of 6600 pounds. This vehicle presently has a normal gross weight of 8250 and maximum gross weight of 9500 pounds; therefore, the load factors for both the DAVI-modified and standard vehicles are proportionately lower.

The results of these analyses showed adequate margins of safety for the DAVI components, and the structural and control system modifications. These results were confirmed by static and fatigue tests.

### FLYING QUALITIES ANALYSIS

A flying qualities analysis was done to determine any appreciable changes due to the installation of the DAVI system. The evaluation compares trim and controllability, speed stability, characteristics in steady sideslip, response to controls in hover, and stick fixed stability of both systems. It was concluded from these analyses that the DAVI system does not appreciably change the flying qualities of the aircraft.

## Operational Limits

In order to determine the operating limits of the DAVI-modified UH-1H helicopter rotor, forces and moments were calculated for various gross weights and cg locations of the vehicle. The conditions calculated were for a collective pull-up hover maneuver, trimmed level flight, and constant bank angle turns. The criterion for flight limitation was the bottoming of any DAVI.

For the collective pull-up hover maneuver, rotor forces and moments were calculated for 6600-lb and 9140-lb gross weights. Vertical load factors from 1.0 to 3.0 for the 6600-lb gross weight and from 1.0 to 1.5 for the 9140-lb gross weight were used. The maximum limit load factor at any weight greater than the basic structural design gross weight (6600 lb) is determined by multiplying the design limit load factor of 3.0 by the ratio of the structural design gross weight to the gross weight in question. The results of these calculations show that the DAVI-modified vehicle is restricted to a 2.8 load factor and 1.85 load factor for the 6600-lb and the 9140-lb gross weights, respectively, at cg station 141.8. The standard vehicle is restricted to a 3.0 load factor and 2.14 load factor for the 6600-lb and the 9140-lb gross weights, respectively.

Rotor hub forces and moments were calculated for 8250- and 9140-lb gross weights for the trimmed level flight condition. Results of these calculations showed no bottoming of the DAVI mounts and, therefore, no restriction on the trimmed level flight of the DAVI-modified UH-1H helicopter.

Rotor hub forces and moments were calculated at 8250- and 9140-lb gross weights for trimmed constant bank turn conditions. Results of these calculations showed that no bottoming of the DAVIs occurred throughout most of the cg range and that the limiting factor was transmission power.

## COMPONENT TESTS

### Pivot Test

Component testing was done early in the program to insure feasibility and confidence in the design. A pivot test was done to determine the life of the spherical bearings selected for the DAVI design. In this test, an inertia bar from a transmission DAVI was used to produce the appropriate loads on the isolated and non-isolated pivots. The tests were performed in steps so as to evaluate the fatigue strength of the inertia bar, as well as to accelerate the bearing wear. At the end of the 360-hour test, the spherical bearing was still performing well. From measurements of bearing wear during these tests, a wear rate was established. Based on this wear rate and an established wear limit, bearing life was calculated to be 1231 hours.

### Spring-Endurance Test

An endurance test of a simulated natural rubber spring element for the lift-link DAVI was also conducted. This 100-hour test was conducted on the mount by applying twice the expected vibratory load at the two-per-rev frequency (10.8 Hertz). Results of this test showed no deterioration of the rubber.

### DAVI Tuning and Spring Rate Tests

Two lift-link DAVIs and nine transmission-mount DAVIs were tested to determine their static spring rates and to tune each of the mounts to an anti-resonance frequency of 10.8 Hertz. Static load versus deflection was measured for each mount. The basic static spring rate was obtained by applying loads from 0 to 3000 pounds to the lift-link DAVI and from 0 to 1500 pounds to the transmission-mount DAVIs. An effective dynamic spring rate (more representative of flight conditions) was obtained by pre-loading the mounts to a representative steady load and applying representative cyclic flight loads.

From the results of these tests, the static spring rate of the system was determined to be 5.5 percent softer than the design goal, and the dynamic spring rate of the system was found to be 3.85 percent stiffer than the design goal. This variation between static and dynamic spring rates was less for the DAVI system than for the standard UH-1H isolation system.

Although this variance in spring rates is within acceptable limits, the DAVI isolation system is more sensitive to spring rate variance than conventional isolation systems. Therefore, each of the DAVI units was individually tuned as a function of the expected vibratory load. The DAVIs were tuned by positioning the movable inertia weight to give a minimum force output at 10.8 Hertz. This gave less than a 2-percent variation in the antiresonance, and the resultant output force effectively compensated for the variance in spring rates.

## SYSTEM TESTS

### Endurance Test

A 100-hour endurance test was conducted on the complete DAVI isolation system. Figure 17 shows a schematic of the test setup. As seen in the figure, a scrap UH-1H transmission and shaft, and a dummy rotor assembly were installed with the complete DAVI isolation system and friction dampers on a rigid steel I-beam structure representing the fuselage. The transmission and I-beam structure were suspended by a soft bungee to simulate a free-free system.



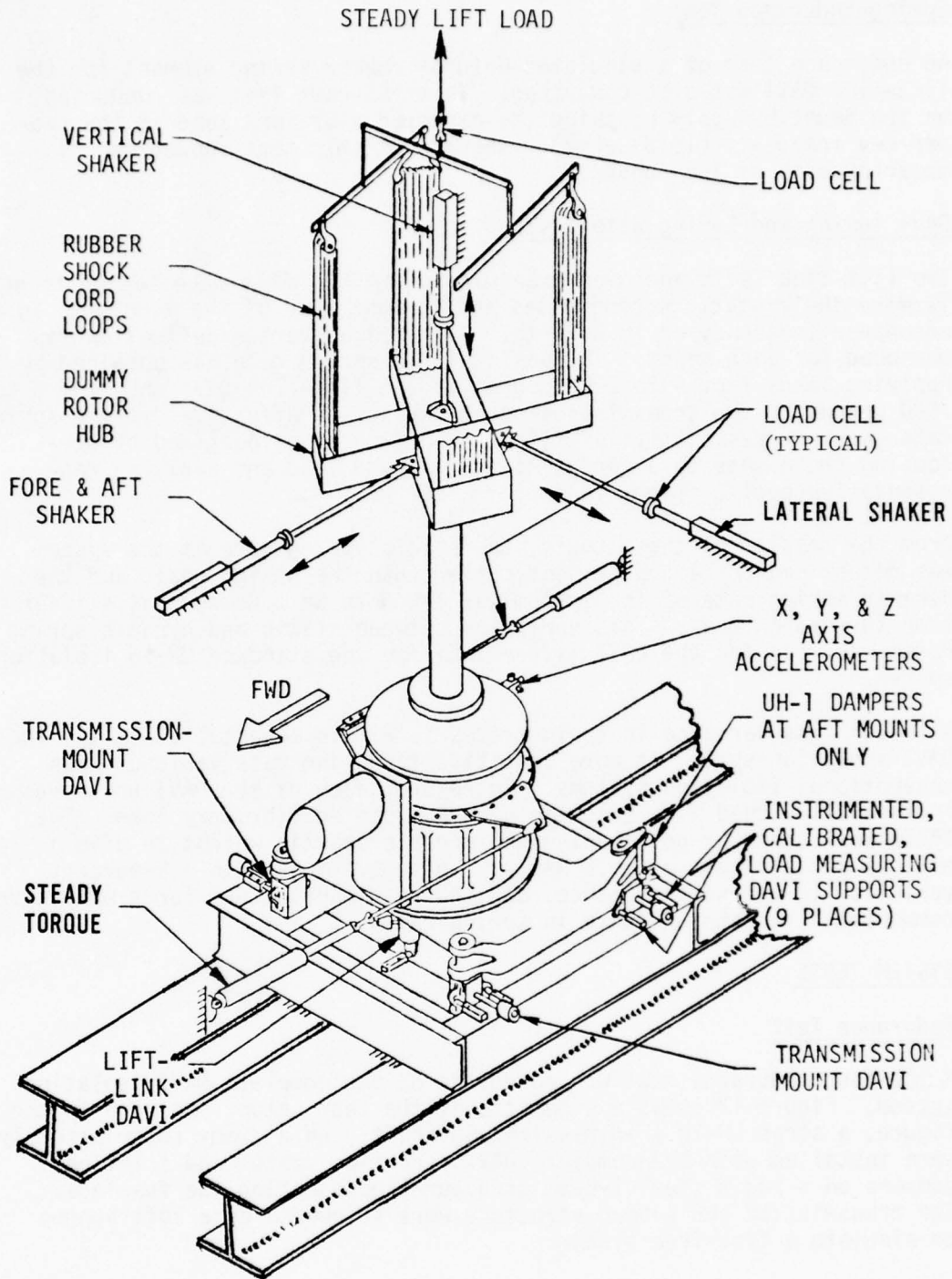

Figure 17. Schematic of Endurance Test Rig

The steady state 1-g level-flight in-plane forces were applied to the hub via loaded trays suspended by soft bungee and pulleys, and the 1-g level-flight vertical force was achieved by appropriately ballasting the I-beam structure representing the fuselage. The steady-state torque was applied to the transmission case rather than the hub to minimize the restraint of the rotor and shaft. These forces on the lower structure (fuselage) were reacted by soft bungee attached to the fixed structure of the test bay area. Vertical, longitudinal, and lateral vibratory forces were applied at the hub via hydraulic shakers.

This endurance test represented the high-speed flight condition of 116 knots for an 8250-lb UH-1H helicopter. The vibratory forces applied at the hub were 1.5 times the forces expected in flight.

Upon completion of the 100-hour endurance, all critical parts were inspected and found to be in good condition. Spring rates of the DAVI mounts were measured and found to be within 1.8 percent of the spring rates measured before the test. From the results of the test and inspection, the DAVI system was determined to have suffered no damage and, therefore, was flightworthy for the planned 20-hour flight test program.

#### Proof Test

The test condition for the DAVI-modified UH-1H helicopter was based on a 45-degree banked turn at 50 knots airspeed (1.429 g normal load factor). The helicopter's gross weight during this maneuver was 9142 pounds. This condition was selected since it is the most critical maneuver planned in this flight test program.

Limit loads were calculated for the test condition and applied to the DAVI-modified UH-1H helicopter, as shown in Figure 18. Figure 18 shows the 125-percent limit load, which was the maximum load applied in this test. This overload was selected as being sufficiently high to ensure an adequate margin over the most severe flight test condition anticipated without placing undue strain on structural areas that were not modified.

The modified flight control system was also proof tested. The loading conditions for this proof load test were the same as those used in the UH-1 helicopter's original control system. The longitudinal-cyclic and collective control systems were tested to 100-percent jam load. A test of the lateral-cyclic system was not required because jam loads of this system produce less severe loads in the changed parts than the jam loads of the longitudinal-cyclic system.

The DAVI-modified helicopter and the modified controls withstood the application of the proof load without failure and permanent set.

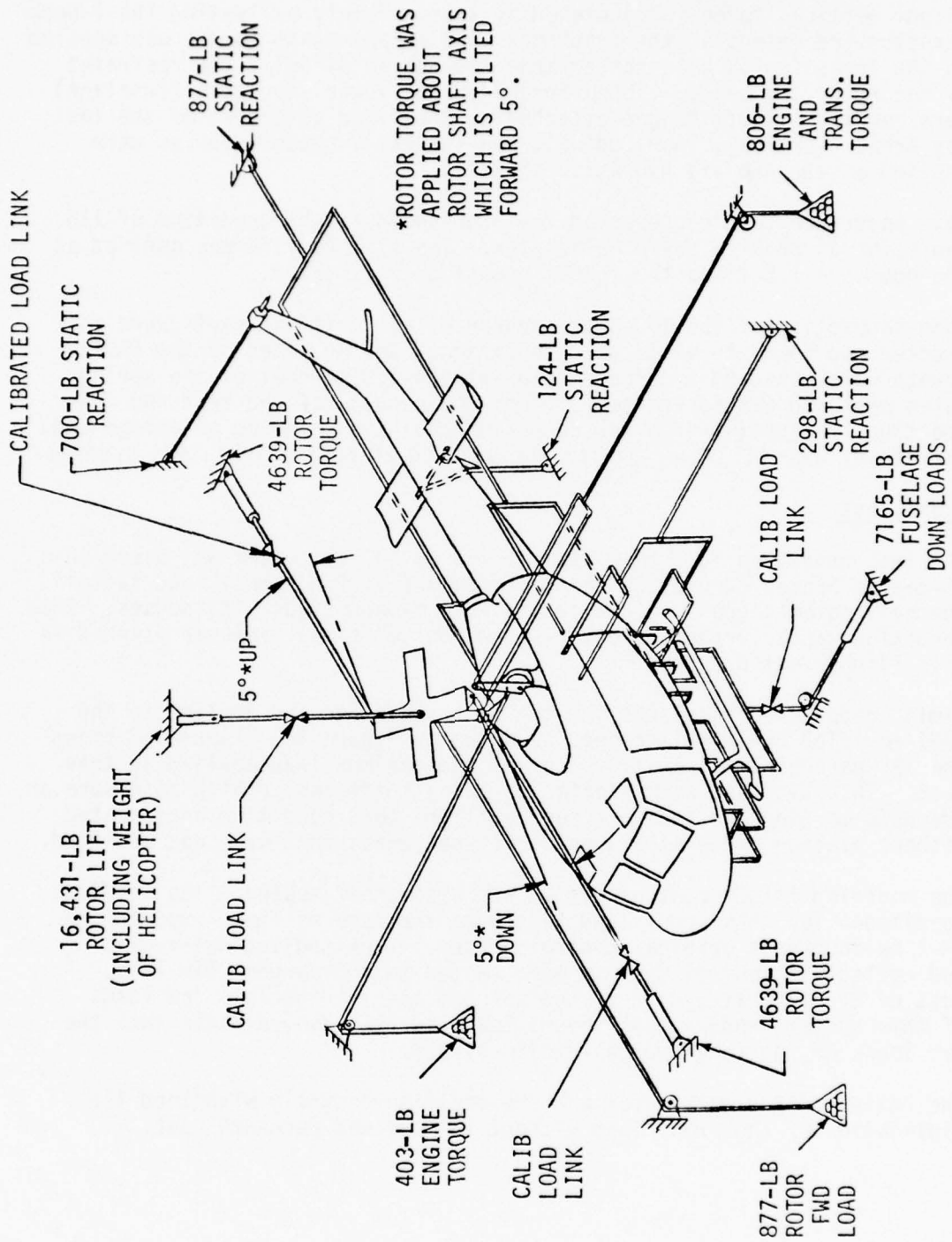

Figure 13. Schematic Diagram of Proof-Load Test

### Ground Vibration Survey

A ground vibration survey was done on the standard system, the DAVI system, and the rigid system (standard isolators locked out). Each configuration of the test vehicle was ballasted to 8250 pounds and suspended by a soft bungee to simulate a free-free system, as shown in Figure 19. All shake tests were done in a similar manner. A frequency sweep was made from 2 Hertz to 25 Hertz for a known force input at the hub in the vertical, longitudinal, and lateral directions, and mobilities (acceleration/force) were obtained. The forces were applied independently and were approximately 1000 pounds except at resonance.

The same instrumentation was used in all tests. This instrumentation included three strain-gage load cells between the hydraulic shakers and the hub attachment to measure the vertical, longitudinal, and lateral vibratory force inputs, nine linear potentiometers to determine the relative motion of the transmission with respect to the isolated fuselage, and eighteen accelerometers to obtain the response of the fuselage. Figure 20 shows the six locations of the accelerometers in these tests; there were three accelerometers at each location that were oriented to give the vertical, lateral, and longitudinal responses. These were the same accelerometers and locations used in the flight test phases.

Using the mobilities obtained in this ground vibration survey of the standard vehicle and the fuselage responses obtained in the flight test of the standard vehicle, two-per-rev forces from the rotor were calculated. Using these forces, the expected flight responses of the DAVI-modified vehicle were calculated for flight versus speed. The calculations showed that a substantial reduction in vibration level should be obtained by the DAVI-modified vehicle as compared to the standard UH-1H helicopter.



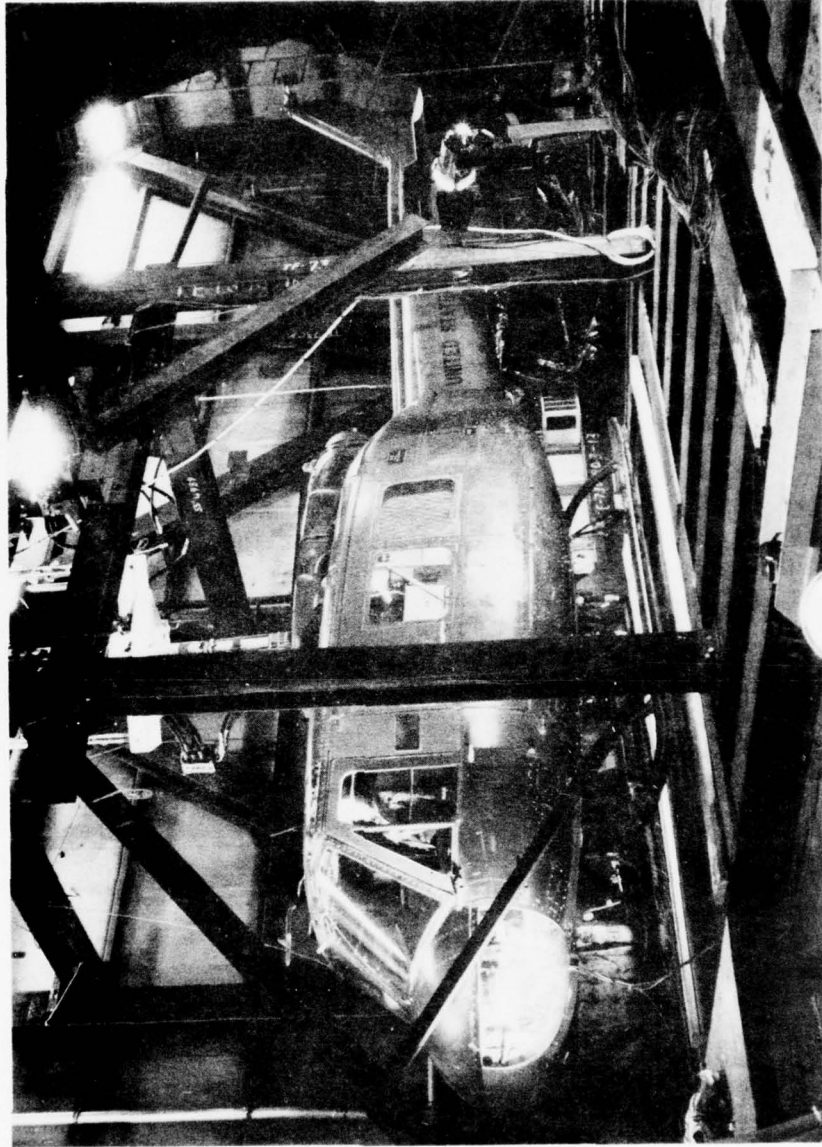

Figure 19. Ground Vibration Test Setup

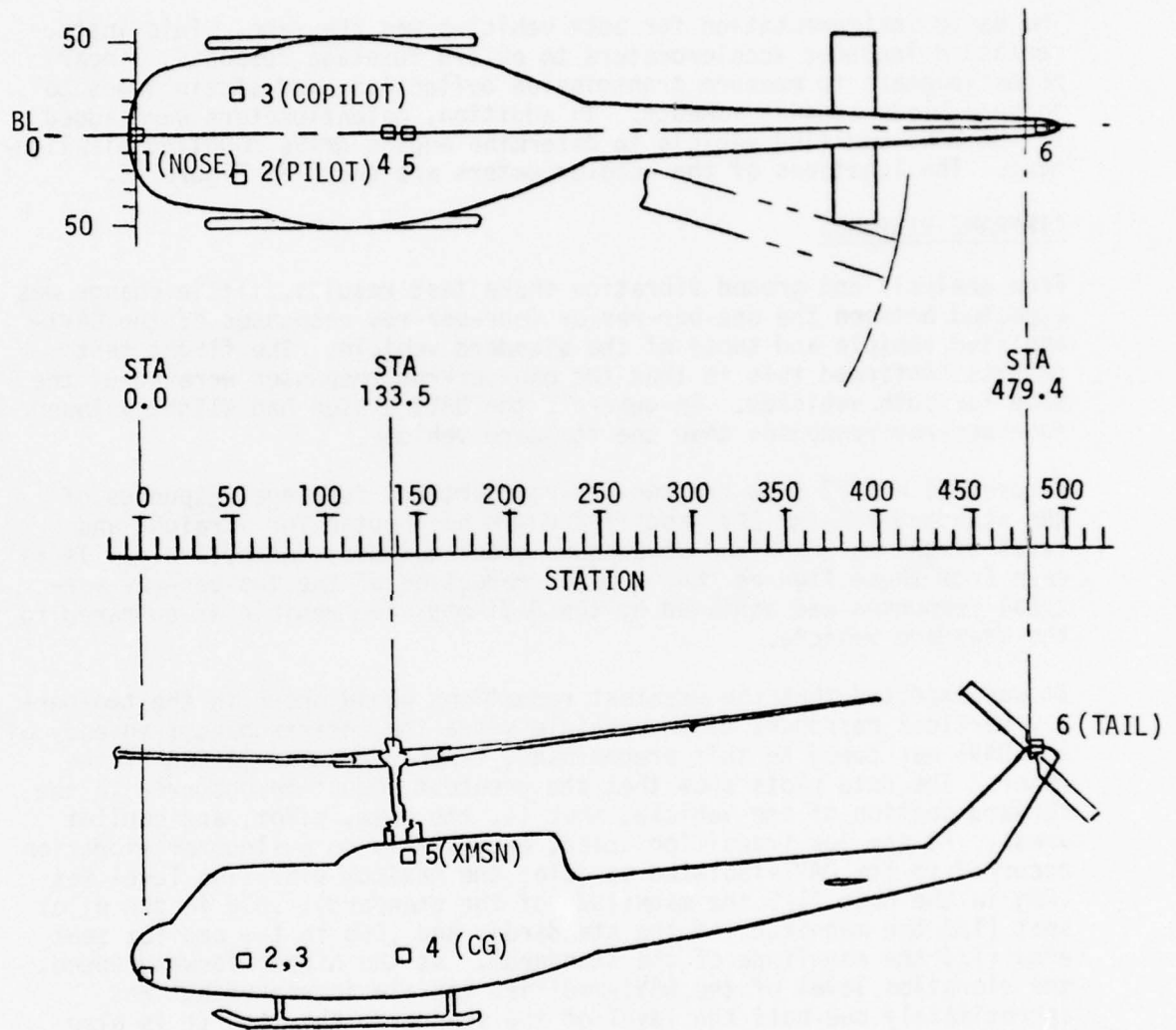

Figure 20. Accelerometer Locations

## FLIGHT TEST

Flight data for both standard and DAVI-modified vehicles were obtained for similar flight conditions on an Army-furnished UH-1H helicopter at 8250- and 9500-pound gross weights. For the DAVI-modified vehicle, the DAVIs were tuned to the predominant two-per-rev excitation frequency of the UH-1H helicopter.

The basic instrumentation for both vehicles was the same. This instrumentation included accelerometers to obtain fuselage response, linear potentiometers to measure transmission deflection, and strain gages to measure blade bending moments. In addition, potentiometers were added to the DAVI-modified vehicle to determine engine drive coupling misalignment. The locations of the accelerometers are shown in Figure 20.

### AIRFRAME RESPONSE

From analysis and ground vibration shake test results, little change was expected between the one-per-rev or four-per-rev responses of the DAVI-modified vehicle and those of the standard vehicle. The flight test results confirmed this in that the one-per-rev responses were about the same for both vehicles. In general, the DAVI system had slightly lower four-per-rev responses than the standard vehicle.

Figures 21 and 22 show the two-per-rev vertical fuselage responses of the standard and the DAVI-modified UH-1H helicopter for straight and level flight at 8250- and 9500-pound gross weights, respectively. It is seen from these figures that a major reduction of the two-per-rev vertical responses was achieved by the DAVI-modified vehicle as compared to the standard vehicle.

It was expected that the greatest reductions would occur in the two-per-rev vertical responses of the vehicle since the antiresonant frequency of the DAVI was tuned to this predominant, two-per-rev excitation of the rotor. The data plots show that the greatest reduction occurred in the forward section of the vehicle, that is, the nose, pilot, and copilot areas. At the low transition speed, essentially no buildup of vibration occurred in the DAVI-isolated vehicle; the maximum vibration level was .05g in the nose (1/5 the magnitude of the standard), .03g in the pilot seat (1/3 the magnitude of the standard), and .06g in the copilot seat area (1/4 the magnitude of the standard). At the higher forward speed, the vibration level of the DAVI-modified vehicle increased but was approximately one-half the level of the standard vehicle. It is also seen that the minimum vibration level of the forward section of the standard vehicle occurs at approximately 50 knots, whereas this same level occurs at approximately 100 knots for the DAVI-modified vehicle.

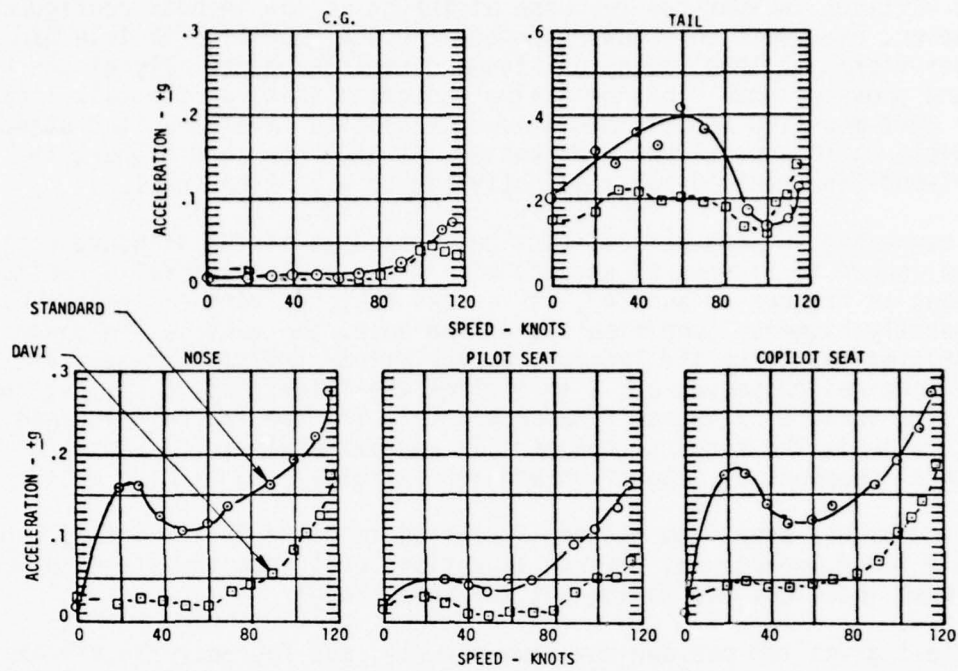

Figure 21. Two-Per-Rev Vertical Response of the 8250-Pound UH-1H Helicopter

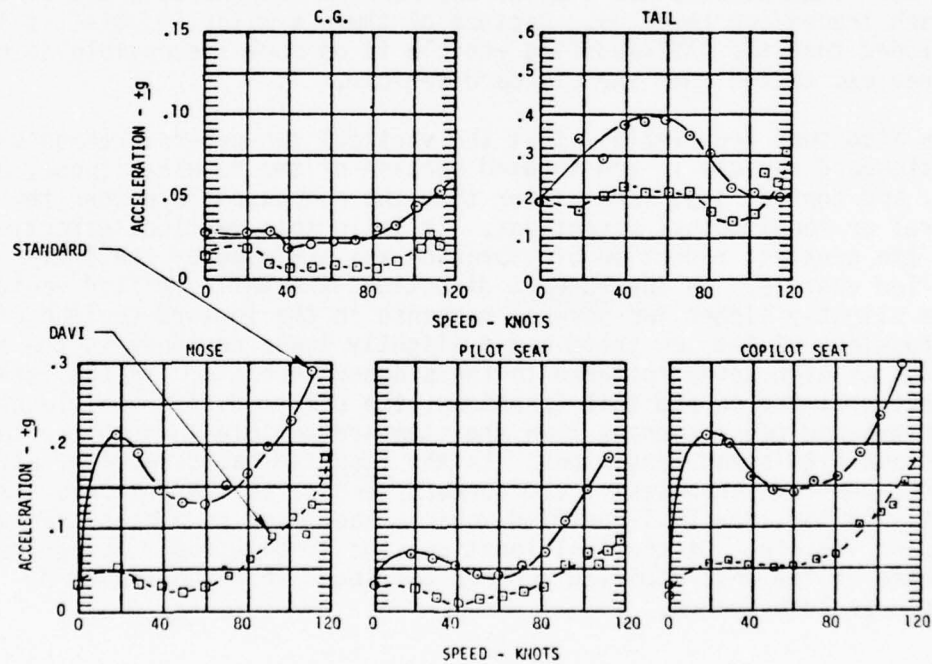

Figure 22. Two-Per-Rev Vertical Response of the 9500-Pound UH-1H Helicopter



The vertical two-per-rev response at the cg is low in both configurations. However, even with this low response, the DAVI-modified vehicle had a lower vibration level than the standard vehicle, especially at the 9500-pound gross weight. This data also indicates that, at the tail location, the DAVI-modified vehicle had a lower vibration level than the standard vehicle up to approximately 80 knots. At 100 knots and higher, the DAVI-modified vehicle had a slightly higher vibration level.

In comparing the two-per-rev vertical responses of the standard configuration (shown in Figures 21 and 22) with those in the lateral direction (shown in Figures 23 and 24), it is seen that the vertical responses are generally higher. Specifically, at the nose, the vertical response is approximately twice the lateral; at the pilot- and copilot-seat locations, the vertical responses are 2 to 3 times the lateral responses; at the cg, the vertical response is approximately 1/2 the lateral response; and at the tail, the vertical response is approximately 1-1/2 times the lateral response at transition and approximately 1/3 at high speed.

It is further seen from Figures 23 and 24 that the DAVI-modified vehicle had a lower two-per-rev lateral vibration level than the standard vehicle at most locations and throughout the speed range.

Table 1 gives the one-per-rev, two-per-rev, and four-per-rev vibratory responses at 30 and 110 knots for the 9500-pound standard and DAVI-modified vehicles. It is seen from this table that the standard and DAVI-modified vehicles had similar one-per-rev responses in all directions at each transducer location. Because of these similar results, it is concluded that the DAVI-modified vehicle is no more susceptible to one-per-rev excitation than the standard vehicle.

It is also seen from Table 1 that the vertical two-per-rev responses of the standard vehicle in the forward section of the fuselage (nose, pilot seat, and copilot seat) are higher than the responses in either the lateral or longitudinal directions. It is in this vertical direction that the greatest reduction of vibration was achieved by the DAVI-modified vehicle. In the lateral direction, the DAVI-modified vehicle had a slightly higher two-per-rev response in the forward section of the fuselage at the low speed and a slightly lower response in the forward section at high speed compared to the standard vehicle. In the lateral direction at the cg and tail locations, the DAVI-modified vehicle had lower two-per-rev responses than the standard vehicle in both the low-speed and high-speed conditions. In the longitudinal direction, although the two-per-rev responses of the forward section of the fuselage are relatively low, the DAVI-modified vehicle had lower responses than the standard vehicle. At the tail location, the longitudinal two-per-rev response of the DAVI-modified vehicle was lower than the standard vehicle at both speeds.

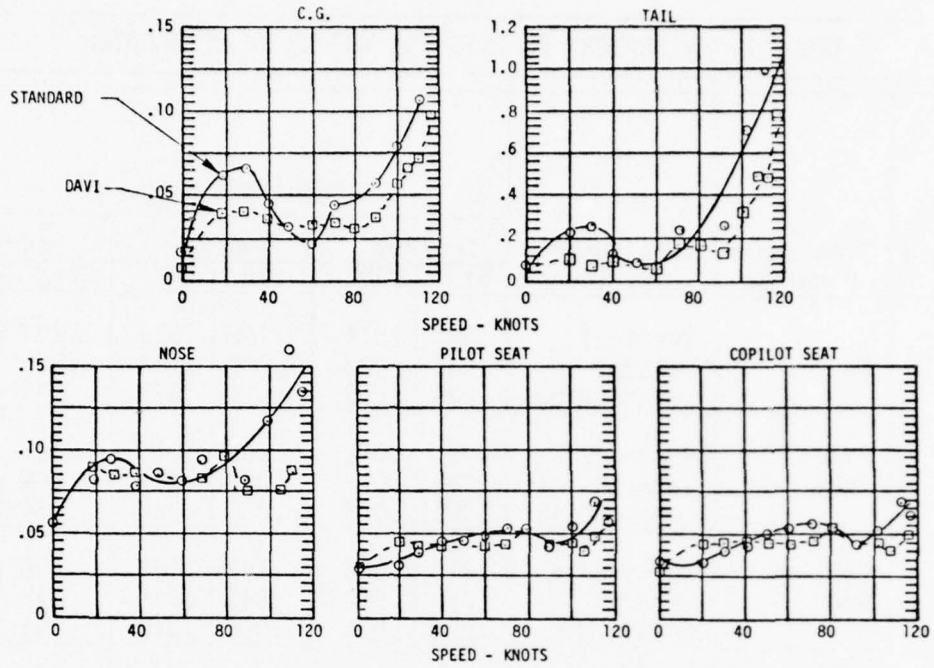

Figure 23. Two-Per-Rev Lateral Response of the 8250-Pound UH-1H Helicopter

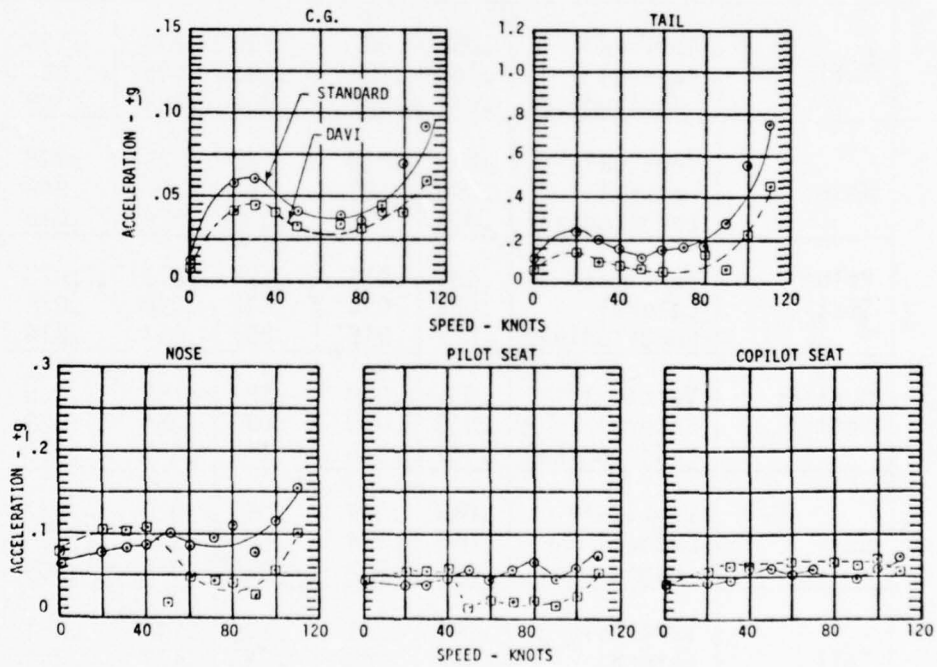

Figure 24. Two-Per-Rev Lateral Response of the 9500-Pound UH-1H Helicopter

TABLE 1. VIBRATORY RESULTS FOR THE UH-1H HELICOPTER

Speed (kn)	Transducer Location	Transducer Direction	Magnitude - $\pm g$					
			One/Rev		Two/Rev		Four/Rev	
			Std	DAVI	Std	DAVI	Std	DAVI
30	Nose	Vertical	.022	.014	.192	.038	.207	.152
		Lateral	.032	.023	.084	.103	.082	.041
		Longitudinal	.004	.003	.030	.031	.033	.029
	Pilot Seat	Vertical	.018	.012	.065	.018	.121	.081
		Lateral	.019	.012	.041	.057	.044	.018
		Longitudinal	.006	.003	.036	.024	.034	.015
	Copilot Seat	Vertical	.018	.008	.197	.059	.204	.082
		Lateral	.020	.012	.043	.061	.042	.022
		Longitudinal	.006	.005	.066	.047	.044	.012
	CG	Vertical	.006	.001	.029	.012	.113	.056
		Lateral	.005	.004	.062	.045	.018	.012
		Longitudinal	.003	.001	.042	.033	.054	.031
	Tail	Vertical	.056	.052	.295	.209	.136	.108
		Lateral	.162	.120	.195	.085	.121	.094
		Longitudinal	.041	.027	.300	.222	.329	.155
110	Nose	Vertical	.039	.020	.286	.129	.098	.037
		Lateral	.090	.100	.153	.100	.046	.064
		Longitudinal	.005	.004	.050	.054	.019	.022
	Pilot Seat	Vertical	.034	.015	.185	.073	.078	.069
		Lateral	.052	.054	.071	.054	.026	.042
		Longitudinal	.012	.015	.067	.057	.014	.021
	Copilot Seat	Vertical	.031	.020	.287	.157	.030	.026
		Lateral	.053	.055	.073	.054	.029	.047
		Longitudinal	.017	.018	.104	.076	.016	.027
	CG	Vertical	.015	.009	.053	.020	.032	.019
		Lateral	.012	.014	.094	.062	.016	.013
		Longitudinal	.004	.002	.039	.044	.009	.019
	Tail	Vertical	.085	.071	.209	.244	.091	.030
		Lateral	.446	.469	.763	.477	.304	.136
		Longitudinal	.049	.037	.315	.244	.209	.254

It is seen from Table 1 that for the four-per-rev responses, the DAVI-modified vehicle had lower vibration levels than the standard vehicle at most locations and speeds. For example, at the copilot location, the DAVI-modified vehicle had approximately one-half the level of the standard vehicle at 30 knots.

In this flight test program, steady-state turn maneuvers were done with the standard and DAVI-modified vehicles. These steady-state turns were conducted at 0, 50, and 90 knots. For these maneuvers, the DAVI-modified vehicle had lower two-per-rev vertical responses than the standard vehicle at virtually every location and speed. For the forward section of the fuselage (nose, pilot seat, and copilot seat), the average vibration level of the DAVI vehicle was approximately one-half the level of the standard vehicle.

#### RELATIVE DISPLACEMENT/COUPLING MISALIGNMENT

One of the major concerns in this program, because of the introduction of vertical isolation, was the possibility that the relative motion between the main gearbox and the engine might cause excessive misalignment of the engine-transmission driveshaft. This misalignment was monitored throughout the flight testing of the DAVI-modified vehicle. Figure 25 shows the vertical and lateral misalignment of the coupling at the transmission. It is seen from these results that the vertical misalignment-versus-speed was small: the greatest misalignment was 0.4 degree at 116 knots for the 8250-pound vehicle. The maximum lateral misalignment, 0.95 degree, occurred at 116 knots for the 9500-pound helicopter. The misalignment could have been reduced to less than 0.5 degree by statically reindexing the coupling in the lateral direction. Without reindexing, the maximum resultant misalignments were 0.81 degree and 0.97 degree for the 8250-pound and 9500-pound vehicles, respectively. These misalignments are well within the allowable continuous misalignment of 2.0 degrees at 1100 horsepower for steady-state flight conditions.

#### ROTOR BLADE STRESSES

As shown in Figure 26, a reconstructed curve based on data extracted from Reference 12, the maximum bending moments for the standard UH-1H main rotor occur at station 0 for the flatwise and chordwise directions.

<sup>12</sup> Maloney and Akeley, DESIGN STUDY OF REPAIRABLE MAIN ROTOR BLADES, Kaman Aerospace Corporation; USAAMRD Technical Report 72-12, Eustis Directorate, U. S. Army Air Mobility Research and Development Laboratory, Fort Eustis, Virginia, July 1972, AD 749283.



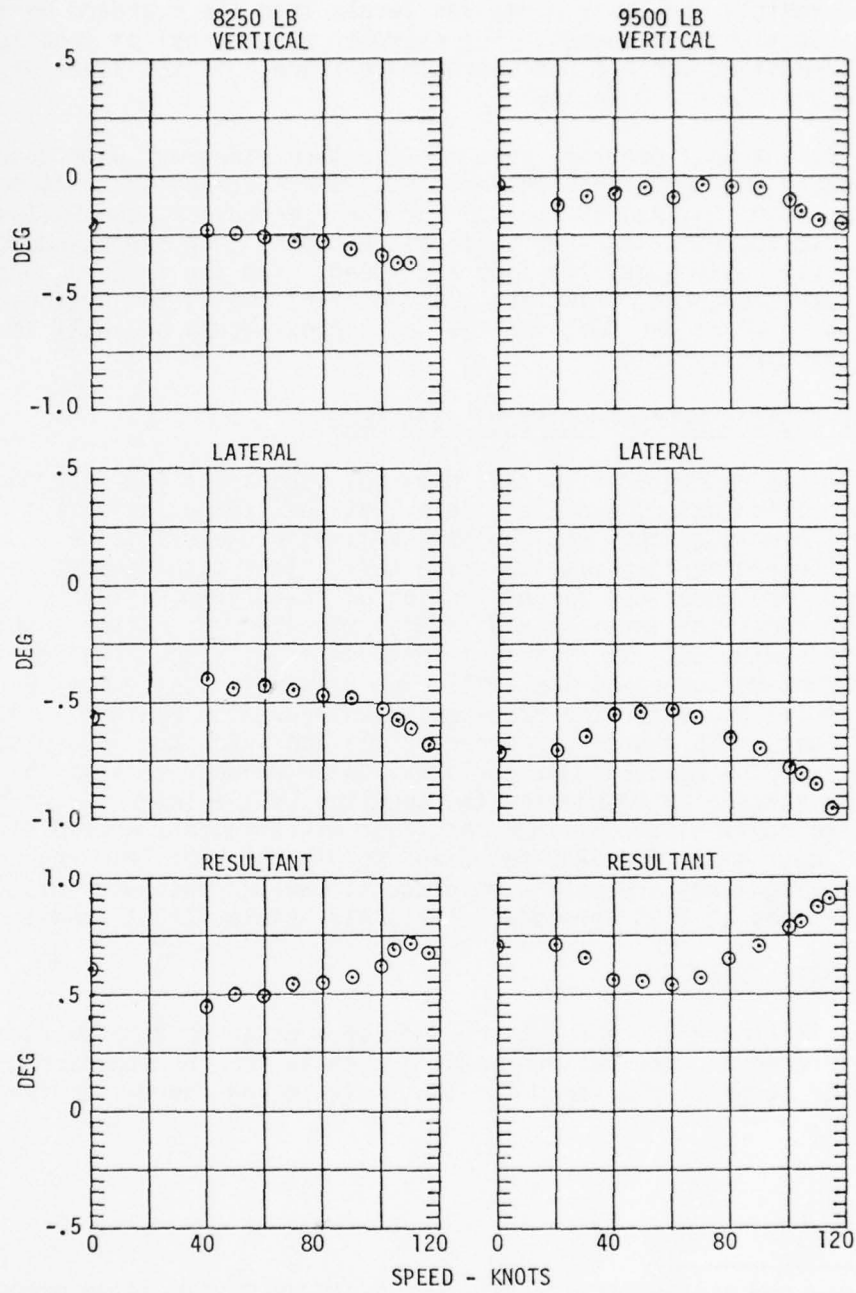

Figure 25. Angular Misalignment of the Engine Drive Coupling in the DAVI-Modified UH-1H

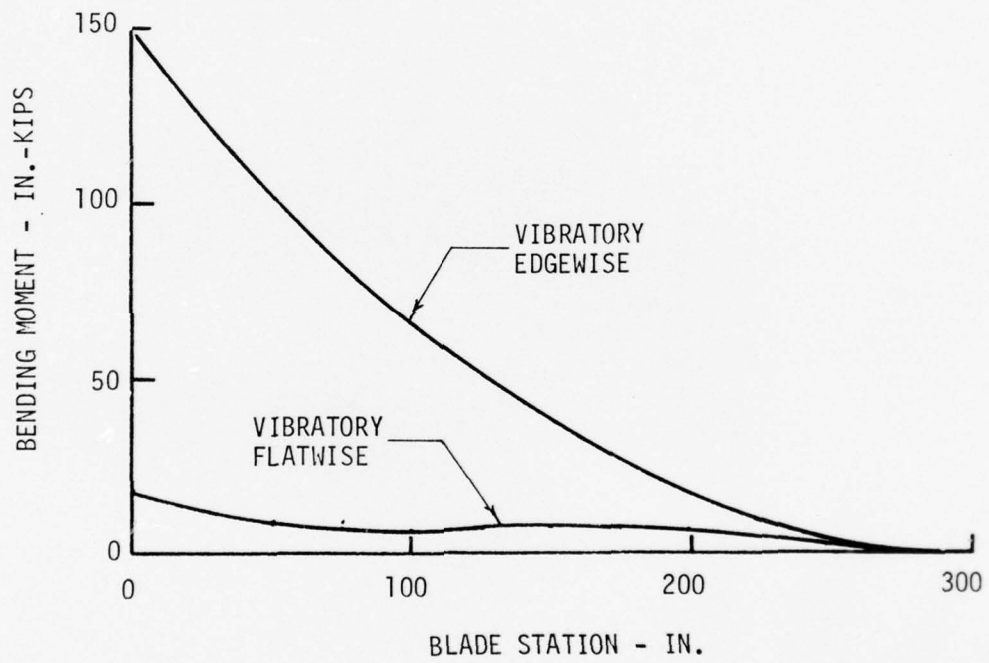

Figure 26. UH-1H Moment Distribution

Strain gage bridges were installed at the sensitive locations of the rotor to monitor these stresses throughout the flight tests for the standard and DAVI-modified UH-1Hs. Blade station 35.0 was monitored for flatwise bending moments, and the drag brace axial load was monitored for the indication of chordwise bending moments. Figure 27 shows the total vibratory flatwise bending moment at Station 35 and the total vibratory axial load in the drag brace. It is seen from these results that no major changes in the blade loading resulted. Thus, it is concluded that the DAVI isolation system has no appreciable effect on rotor blade loads.

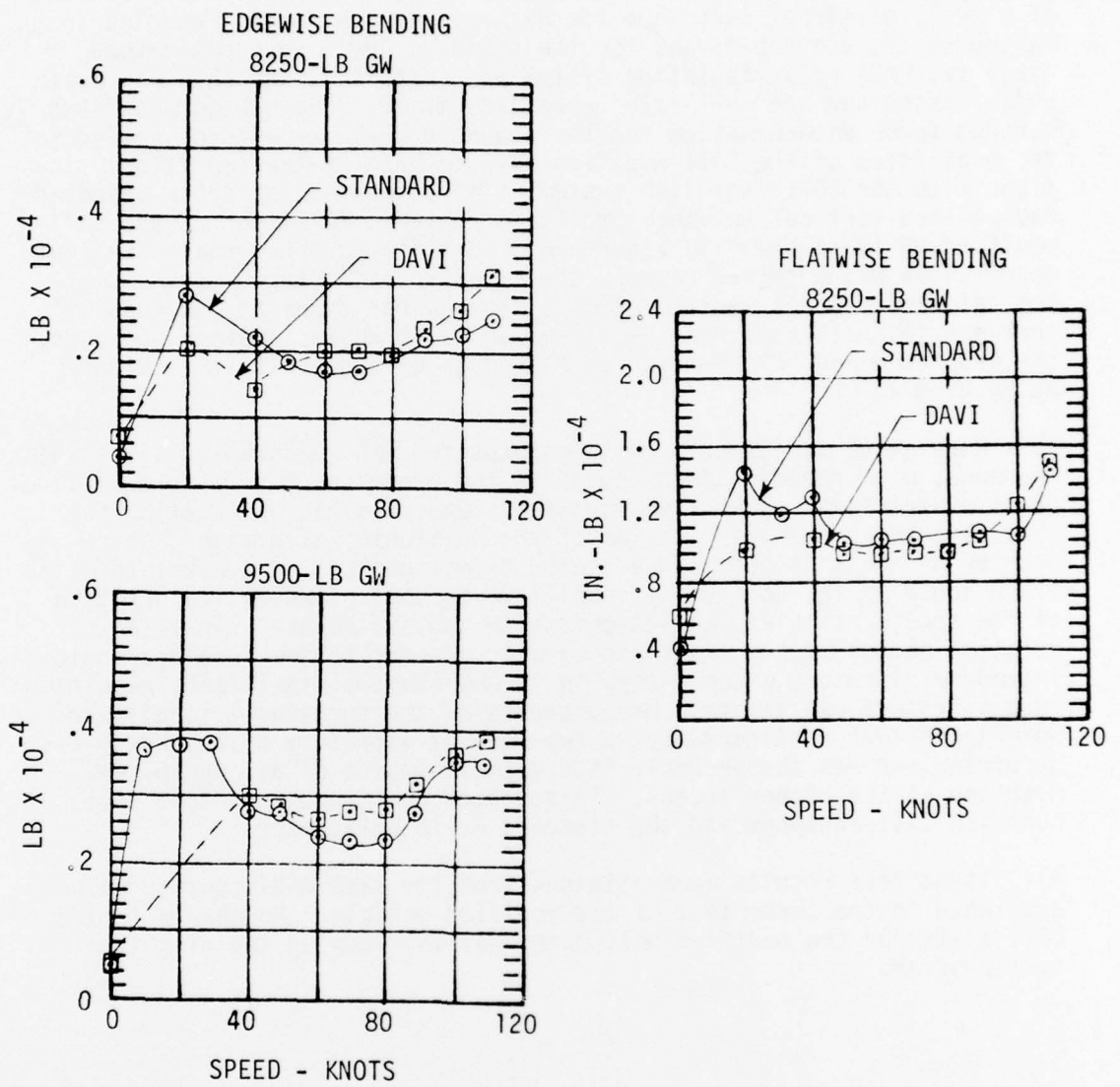

Figure 27. Main Rotor Blade Loads Comparison



## CORRELATION

Prior to installation of the DAVI rotor isolation system, the UH-1H test vehicle was both flown and shake tested to obtain baseline fuselage responses and mobility data. Using this data and a preliminary version of a newly developed technique for determining hub forces reported in Reference 13, the hub forces for the standard UH-1H were determined. After the DAVI rotor isolation system was installed, the ship was again shake tested and the mobilities were determined. The hub forces found through force determination for the standard UH-1H were then applied to the mobilities of the DAVI-modified ship to predict the new flight vibrations with the DAVI isolation system. The comparison of these expected two-per-rev vertical responses to those recorded in flight on the DAVI-modified UH-1H is shown in Figure 28. This figure shows that excellent correlation was obtained between the expected and actual responses at the tail and pilot's seat locations. The correlations at the copilot's seat and nose stations were excellent up to 80 knots. Beyond 80 knots, the predicted and flight-measured responses diverge, with the latter being higher.

This divergence or disparity between expected and measured results, which increases with forward speed, suggests the presence of some form of aerodynamic excitation other than downwash. One possible explanation for this is a two-per-rev excitation of the horizontal stabilizer, which is mounted on the tail boom and actuated by motions of the swashplate. The pitch angle of the horizontal stabilizer is controlled by the position of the cyclic stick via an attachment to the swashplate. Thus, any relative motion of the transmission with respect to the fuselage could introduce vibratory pitch change in the horizontal stabilizer, resulting in a vibratory excitation. Measurements of the horizontal stabilizer were taken that confirmed that a two-per-rev vibratory pitch change was occurring and was the probable "additional" source of aerodynamic excitation at the higher speeds. This effect was found in flight tests of both the DAVI-equipped and the standard UH-1H helicopter.

All flight test results were obtained from the same DAVI configuration developed in the shake test of the modified vehicle. No change to the DAVI system or the modified helicopter was made during the flight test program.

---

<sup>13</sup> Flannelly, Bartlett, and Forsberg, LABORATORY VERIFICATION OF FORCE DETERMINATION, A POTENTIAL TOOL FOR RELIABILITY TESTING, Kaman Aerospace Corporation; USAAMRDL Technical Report 76-38, Eustis Directorate, U. S. Army Air Mobility Research and Development Laboratory, Fort Eustis, Virginia, January 1977, AD A035960.

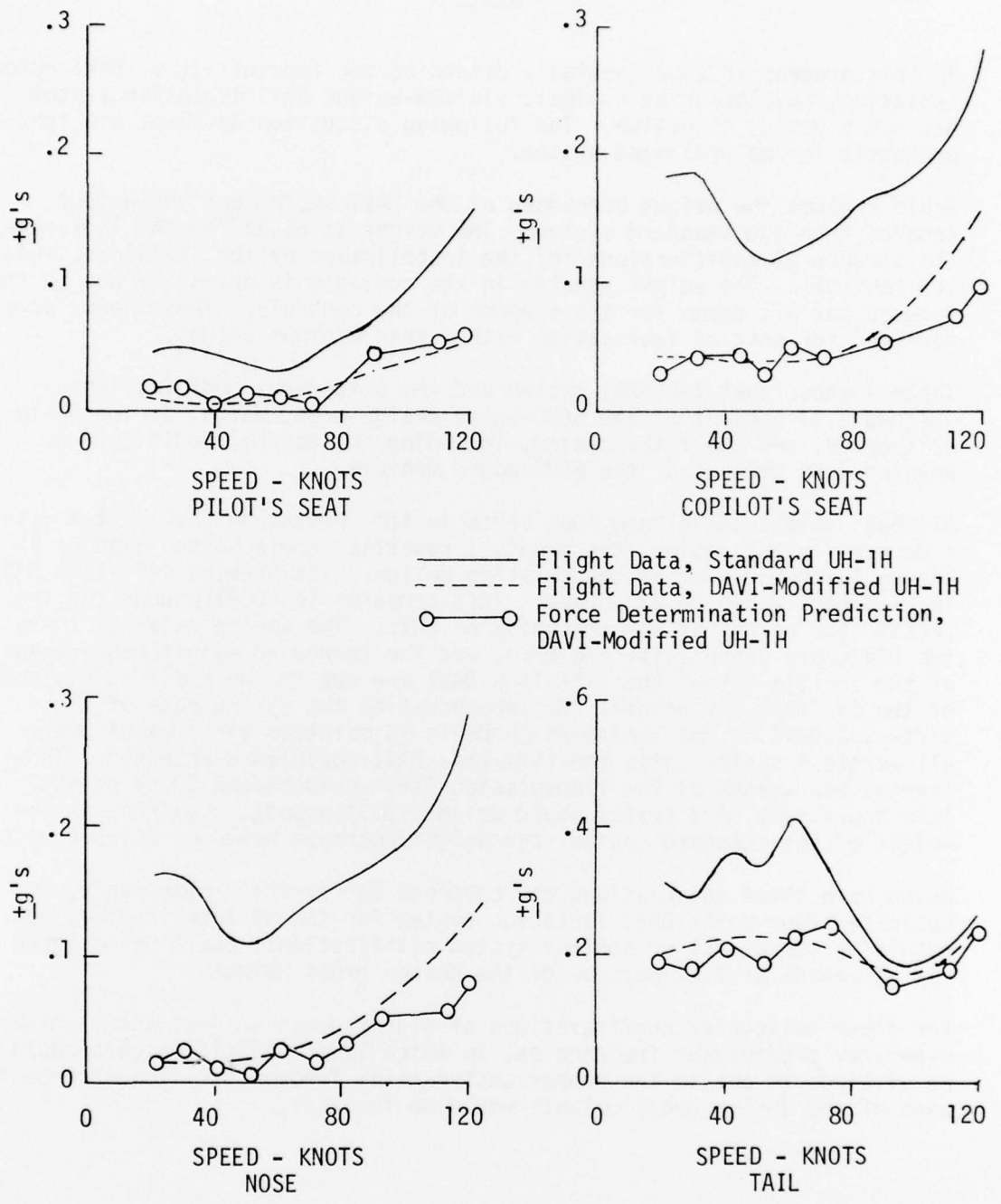

Figure 28. Predicted and Actual Two-Per-Rev Vertical Responses of the UH-1H

## WEIGHT

In this program to experimentally determine the feasibility of DAVI rotor isolation, developing an optimal, minimum-weight DAVI isolation system was not a design objective. The following discussion develops a weight prognosis for an optimized system.

Table 2 gives the weight breakdown of the DAVI system and the weight removed from the standard system. The weight is given for the isolators, the structural modifications for the installation of the isolators, and the controls. The weight penalty in the controls is primarily due to the forward and aft beams for the support of the controls. These beams were designed for ease of fabrication rather than minimum weight.

Table 2 shows that the DAVI system and the structural modifications weighed 2.31 percent of the 6600-pound design gross weight of the UH-1H helicopter, and the total system, including the control modification, weighed 3.15 percent of the 6600-pound vehicle.

Although weight could have been saved in this prototype DAVI system with a more efficient design, the greatest reduction could be achieved by a change in the concept of the existing design. The present lift-link DAVI inertia bars weigh 24.93 pounds. This compares to 10.81 pounds for the inertia bar weight of the transmission DAVI. The spring rates of these two DAVIs are essentially the same, and the increased weight requirements of the inertia bar of the lift-link DAVI are due to the small cg distance of the bar from the pivots. By incorporating the spring rate of the lift-link DAVI in the transmission DAVIs to maintain the present overall vertical spring rate, the lift-link DAVI could be eliminated. The inertia bar weight of the transmission DAVI would become 13.51 pounds. This four-point DAVI system would weigh 113.32 pounds. Subtracting the weight of the standard system, the weight increase would be 84.05 pounds.

Based upon these calculations and concepts for further refinements, an optimized four-point DAVI isolation system for the UH-1 helicopter, not requiring structural or control system modifications, could be designed for 84 pounds or 1.27 percent of the design gross weight.

For other helicopter configurations of higher gross weights and/or higher n-per-rev predominant frequencies, in which lower inertia weights could be utilized to obtain the proper antiresonant frequencies, lower percentages of the design gross weights would be feasible.

TABLE 2. ISOLATION SYSTEM WEIGHT

Number	Item	Unit Weight	Weight
DAVI ISOLATION SYSTEM			
4	Transmission-Mount DAVI	29.69	118.76
1	Lift-Link DAVI	36.36	36.36
Subtotal			155.12
STANDARD ISOLATION SYSTEM			
1	Lift-Link	2.13	2.13
4	Transmission Mounts	4.41	17.64
1	Fifth Mount	4.25	4.25
1	Support Beam, Fifth-Mount	5.25	5.25
Subtotal			29.27
Net Weight Increase, DAVI Isolation System			125.85
STRUCTURAL MODIFICATIONS			
Structure Added			53.27
Structure Removed			26.42
Net Weight Increase, Structural Modifications			26.85
CONTROL MODIFICATIONS			
Controls Added			
Fwd, and Aft Beam			43.34
Rods, Cranks, and Idlers			28.42
Subtotal			71.76
Controls Removed			16.83
Net Weight Increase, Control Modifications			54.93
Total Weight Increase, Isolation System, Structural and Control System Modifications			207.63



## DAVI RELIABILITY ANALYSES

### FAILURE MODES AND EFFECTS ANALYSIS

A failure modes and effects analysis (FMEA) was done to determine any critical failure areas of the design which would have serious effects on mission success and crew safety. The FMEA evaluates each of the critical components to establish possible modes of failure, the causes of failure, the effects of failures on operation of the DAVI unit, and qualitative estimates of the criticalities of the failure to safety and mission success. The failure criticality category and probability classification codes are defined as follows:

#### Failure Criticality Categories

Category I: Negligible - Any nuisance failure not serious enough to be classified in a higher category that is not expected to result in personnel injury or aircraft system damage, but will require corrective action during routine preventive maintenance.

Category II: Marginal - Any failure that is expected to degrade performance or result in degraded operation that can be counteracted or controlled without injury to personnel or major aircraft system damage. It requires special operation techniques or alternative modes of operation that could be tolerated throughout a mission but should be corrected immediately upon completion of the mission.

Category III: Critical - Mandatory Abort - Any failure that is expected to result in complete loss of function and cause personnel injury/hazard or major aircraft system damage, or which will require immediate corrective action for personnel or aircraft system survival.

Category IV: Catastrophic - Any single failure which is expected to cause death or severe injury to personnel or loss of the aircraft system.

#### Failure Probability Classes

Class A: Probability of failure is not remote.

Class B: Probability of failure is remote.

Class C: Parts subject to rare, random failures.

Class D: Parts not expected to fail in service.

The most probable DAVI-isolator failures are predicted to be in the rubber springs and pivot bearings, with deterioration or wear of these components being judged the most likely failure modes. Failures of this type are not serious and can be corrected during routine maintenance. For this reason, they have been assigned a Category I criticality code. Of all the assumed spring and bearing failures, only bond failure and shear of the rubber spring and a jammed bearing are considered serious enough to warrant a Category III criticality code and to require a mandatory abort; however, none of these failures appear to be very probable. In addition, these are likely to be sequential failures that can occur after one of the less serious initial failures is allowed to progress without corrective action being taken. Thus, the need for strict inspection and maintenance procedures to prevent serious failures is obvious.

The DAVI design concept is simple and reliable, and incorporates a fail-safe feature. If a serious spring failure occurs, the isolated fuselage mounting would be restrained by the stops of the non-isolated transmission mounting, both of which are primary structures, thus preventing a total separation. However, such a failure is very likely to cause a mandatory abort due to the high level of vibration transmitted to the fuselage through the primary structure, although rubber-to-rubber stops are provided.

In comparing the conventional UH-1H isolation system with the DAVI system, any differences in overall reliability would result primarily from differences in their respective parts. Since both the conventional and DAVI isolators use many common functional elements, there are actually only very slight differences in the two designs. Both employ rubber springs incorporated in fail-safe mountings, so that there is little difference in this functional area. Both employ bearings; however, the increased number of bearings used in the DAVI isolation system is expected to account for any differences in reliability that might exist between the two.

From a safety of flight viewpoint, the additional bearings of the DAVI system do not present a serious problem. Wear is the most probable cause of bearing failure, but with proper inspection and maintenance, very few serious bearing failures are likely to occur. However, when such failures do occur, the most likely effect on the DAVI system is degradation in vibration isolation, which does not represent a critical situation.

In summary, any decrease in isolation system reliability for the DAVI design compared to the conventional UH-1 isolator design, relative to mission performance, is expected to be minimal and should be no more than a minor offset compared to the gain in overall aircraft reliability resulting from reduced rotor induced vibration.

## COST EFFECTIVENESS

Vibration is known to be one of the major contributors to helicopter equipment failures, its impact varying with such factors as the type of equipment, the location of the equipment, and the method of isolation. Although the relationship between vibration and equipment failure has not been investigated thoroughly, one earlier study, conducted for the Army by Sikorsky Aircraft, estimated that failure rates were reduced as much as 48 percent as a result of incorporating bifilar vibration absorbers on USAF H-3 helicopters (Reference 10).

Data recorded during the flight test of a DAVI-equipped UH-1 has shown that two-per-rev vertical vibrations are reduced by 52 to 74 percent depending on location aboard the aircraft. If the correlation between vibration level and failure rate can be estimated for the various aircraft subsystems, as is assumed in this analysis and in Reference 10, then the experimentally measured vibration reductions for the DAVI-equipped UH-1 helicopter can be applied to UH-1 historical maintenance data to estimate corresponding reductions in aircraft failure rate and maintenance man-hour requirements at all maintenance levels. The resultant labor and repair parts dollar cost savings over the aircraft life cycle can also be estimated.

No cost categories other than maintenance labor and parts have been evaluated in the analysis. However, a number of other cost elements would be reduced indirectly by the potential improvement in reliability allowed by the DAVI system. These include depot pipeline spares cost, spares inventory cost, and spares packaging and shipping costs. Although the consideration of these cost elements was not possible within the scope of the analysis, they are expected to have a significantly smaller impact on maintenance cost savings than labor and repair parts costs. An increase in aircraft availability can also be expected as a result of less frequent maintenance requirements. The cost savings associated with increased availability would also require a more detailed analysis than is possible at this time.

The percent reduction in vibration induced failures for the UH-1 has been estimated from the DAVI/UH-1 flight test data. Only two-per-rev vibration levels in the vertical plane have been considered in this analysis. Percent reduction in vibration levels for the DAVI-modified vehicle compared to the standard UH-1 are average values calculated for aircraft gross weights of 8250 and 9500 pounds over the speed range from 20 to 110 knots. Since the relationship between vibration and subsystem failures has never been thoroughly investigated, best-guess estimates of the percentages of vibration induced failures were made for the

---

<sup>10</sup> Veca

common hardware and primary failure categories for the UH-1 helicopter. The overall failure rate reduction for the DAVI-modified UH-1 aircraft was conservatively estimated to be 31.3 percent.

The estimated labor cost savings were calculated based upon this 31.3 percent reduction in failure rate. Dollar per flight-hour savings were calculated on the bases of \$11.50 per labor hour at the organizational and intermediate levels and \$12.75 per hour at the depot level, resulting in an overall labor cost savings for the DAVI-modified UH-1 that has been estimated to be \$8.94 per flight hour in 1975 dollars.

An estimate of repair parts savings was made based on the UH-1 parts usage rate and the estimated overall percent failure rate reduction. For the 31.3 percent failure rate reduction, the estimated repair parts saving is \$41.32 per flight hour. Therefore, the total maintenance labor and repair parts savings for a DAVI-modified UH-1 is \$50.26 per flight hour.

According to Reference 11, the Army has 3208 UH-1H helicopters, of which 80.11 percent are actually deployed at a current utilization rate of 20 flight-hours per month. Assuming that 1000 aircraft were to be retrofitted, thereby achieving the benefit of the lower costs associated with volume production, the total cost of retrofitting is estimated to be approximately \$7,000,000. This is based on a cursory estimate of about \$5000 to modify each vehicle (\$5,000,000), in addition to a \$2,000,000 non-recurring developmental cost to optimize the envisioned DAVI system. In contrast, the annual savings would be \$12,000,000. Of this savings, \$9,600,000 could be realized from the reduced need for replacement parts; the remaining \$2,400,000 savings could be realized from the associated reduction in maintenance labor.



## CONCLUSIONS

From the results of this flight test program on a DAVI-modified vehicle in which substantial reduction in vibration level was obtained as compared to a standard UH-1H helicopter, it is concluded that:

1. Rotor isolation using the Dynamic Antiresonant Vibration Isolator reduced vibration significantly, which can be projected into significant operational cost savings. In addition, the large reduction in vibration was attained on a helicopter that already had a conventional vibration reduction system installed.
2. Flying qualities of the UH-1H helicopter were not affected by DAVI rotor isolation.
3. Excessive deflection did not occur and misalignment of the engine drive coupling is not a problem.
4. A DAVI isolation system can be designed to insure freedom from mechanical instability and to insure engine-rotor torsional compatibility.
5. Damping in the DAVI isolation must be low to insure low vibration levels.
6. A DAVI rotor isolation system can be designed to be 1.27 percent or less of the gross weight of the helicopter.
7. Reduction in operational costs in the field can be achieved because of the low vibration levels.

## RECOMMENDATIONS

Because of the success of this program, this contractor recommends a continued effort in research and development for rotor isolation and related areas. These recommendations are:

1. Flight testing be continued on the existing modified vehicle to determine improvements in design and to achieve even lower levels of vibration. This flight test program should include at least:
  - (a) The determination of the effects of the vibratory forces from the horizontal stabilizer on the vibration level of the modified vehicle.
  - (b) An assessment of the value of a four-point DAVI system, wherein a lift-link DAVI is not used for reducing vibration levels.
  - (c) The reorientation of the standard friction dampers to a longitudinal direction to determine the effects on the flying qualities and vibration levels of the modified vehicle.
2. Several UH-1H vehicles should have the DAVI rotor isolation system installed for evaluation by Army personnel in the field. This evaluation should concentrate on documenting the effects of reduced vibration on pilot fatigue and R&M.
3. Although not necessarily associated with rotor isolation, the present DAVI-modified helicopter is an ideal vehicle on which to determine the effects of hub impedance on rotor loads. It is therefore recommended that several settings of the tuning weights be used in a shake test performed to determine the hub impedance with these known hub impedances. A flight test can be done to determine the effects of hub impedance on rotor loads.
4. Because of the wide use of elastomers for isolation (as in both DAVI and standard systems) and in the rotor heads for effective hinges, a better understanding of the damping, and the static and dynamic spring of elastomers is required. It is highly recommended that further research be done to determine these characteristics and that a design manual or charts be developed.

## REFERENCES

1. Theobald and Jones, ISOLATION OF HELICOPTER ROTOR VIBRATION FORCES FROM THE FUSELAGE, Kaman Aircraft, Bloomfield, CT, WADC Technical Report 57-404, Wright Air Development Center, Dayton, OH, September 1957.
2. Crede and Cavanaugh, FEASIBILITY STUDY OF AN ACTIVE VIBRATION ISOLATOR FOR A HELICOPTER ROTOR, Barry Wright Corp., WADC Technical Report 58-163, Wright Air Development Center, Dayton, OH, October 1958.
3. Smollen, Marshall and Gabel, A SERVO-CONTROLLED ROTOR VIBRATION ISOLATION SYSTEM FOR THE REDUCTION OF HELICOPTER VIBRATION, Institute of Aerospace Sciences Paper No. 62-34, New York, NY, January 1962.
4. Schuett, PASSIVE HELICOPTER ROTOR ISOLATION USING THE KAMAN DYNAMIC ANTIRESONANT VIBRATION ISOLATOR (DAVI), USAAMRDL Technical Report 68-46, Eustis Directorate, U. S. Army Air Mobility Research and Development Laboratory, Fort Eustis, VA, December 1968, AD 687324.
5. Calcaterra and Schubert, ISOLATION OF HELICOPTER ROTOR-INDUCED VIBRATIONS USING ACTIVE ELEMENTS, USAAMRDL Technical Report 69-8, Eustis Directorate, U. S. Army Air Mobility Research and Development Laboratory, Fort Eustis, VA, June 1969, AD 859806.
6. Jones, A FULL-SCALE EXPERIMENTAL FEASIBILITY STUDY OF HELICOPTER ROTOR ISOLATION USING THE DYNAMIC ANTIRESONANT VIBRATION ISOLATOR, USAAMRDL Technical Report 71-17, Eustis Directorate, U. S. Army Air Mobility Research and Development Laboratory, Fort Eustis, VA, June 1971, AD 729317.
7. von Hardenberg and Saltanis, GROUND TEST EVALUATION OF THE SIKORSKY ACTIVE TRANSMISSION ISOLATION SYSTEM, USAAMRDL Technical Report 71-38, Eustis Directorate, U. S. Army Air Mobility Research and Development Laboratory, Fort Eustis, VA, September 1971, AD 736347.
8. Shipman, NODALIZATION APPLIED TO HELICOPTERS, Society of Automotive Engineers Paper Number 730893, Presented at National Aerospace Engineering and Manufacturing Meeting, Los Angeles, CA, October 1973.
9. Ellis, Diamond and Fay, DESIGN DEVELOPMENT AND TESTING OF THE BOEING VERTOL/YUH-61A, American Helicopter Society Paper Number 1010, Presented at 32nd Annual National Forum, Washington, D.C., May 1976.

REFERENCES (Continued)

10. Veca, VIBRATION EFFECTS ON HELICOPTER RELIABILITY AND MAINTAINABILITY, Sikorsky Aircraft; USAAMRDL Technical Report 73-11, U. S. Army Air Mobility Research and Development Laboratory, Fort Eustis, VA, April 1973, AD 766307.
11. EXECUTIVE SUMMARY REPORT - UH-1H ASSESSMENT AND COMPARATIVE FLEET EVALUATION, USAAVSCOM Technical Report 75-3, U. S. Army Aviation Systems Command, St. Louis, MO, April 1975.
12. Maloney and Akeley, DESIGN STUDY OF REPAIRABLE MAIN ROTOR BLADES, Kaman Aerospace Corporation; USAAMRDL Technical Report 72-12, Eustis Directorate, U. S. Army Air Mobility Research and Development Laboratory, Fort Eustis, VA, July 1972, AD 749283.
13. Flannelly, Bartlett, and Forsberg, LABORATORY VERIFICATION OF FORCE DETERMINATION, A POTENTIAL TOOL FOR RELIABILITY TESTING, Kaman Aerospace Corporation; USAAMRDL Technical Report 76-38, Eustis Directorate, U. S. Army Air Mobility Research and Development Laboratory, Fort Eustis, VA, January 1977, AD A035960.



78