

AD-A050 442

NAVAL RESEARCH LAB WASHINGTON D C  
A METHOD FOR AUTOMATIC TEST AND EVALUATION OF MICROWAVE TRANSCE--ETC(U)  
NOV 77 L J LAVEDAN, M LAING, B SHELEG

F/G 17/9

UNCLASSIFIED

NRL-MR-3662

SBIE-AD-E000 084

NL

1 OF  
AD  
A050442



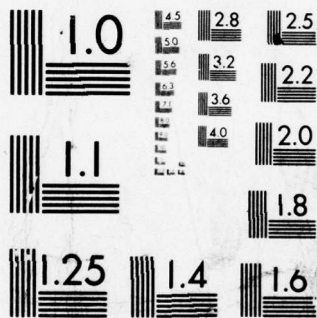

MICROCOPY RESOLUTION TEST CHART  
NATIONAL BUREAU OF STANDARDS-1963-A

12

NRL Memorandum Report 3662

AD-A050442

Adel 000 084

# A Method for Automatic Test and Evaluation of Microwave Transceivers at L-Band Frequencies

LOUIS J. LAVEDAN and MICHAEL LAING

*Space Systems Division*

BORIS SHELEG

*Electronics Technology Division*

November 1977

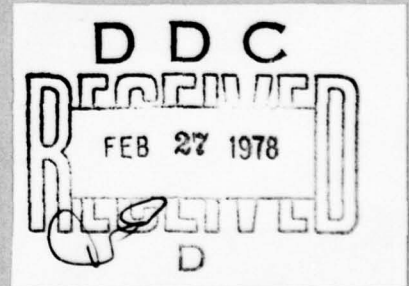

NAVAL RESEARCH LABORATORY  
Washington, D.C.

Approved for public release; distribution unlimited.

REPORT DOCUMENTATION PAGE		READ INSTRUCTIONS BEFORE COMPLETING FORM
1. REPORT NUMBER NRL Memorandum Report 3662	2. GOVT ACCESSION NO.	3. RECIPIENT'S CATALOG NUMBER
4. TITLE (and Subtitle) A METHOD FOR AUTOMATIC TEST AND EVALUATION OF MICROWAVE TRANSCEIVERS AT L-BAND FREQUENCIES		5. TYPE OF REPORT & PERIOD COVERED Interim report on a continuing NRL problem.
		6. PERFORMING ORG. REPORT NUMBER
7. AUTHOR(s) Louis J. Lavedan, Michael Laing and Boris Sheleg		8. CONTRACT OR GRANT NUMBER(s)
9. PERFORMING ORGANIZATION NAME AND ADDRESS Naval Research Laboratory Washington, D.C. 20375		10. PROGRAM ELEMENT, PROJECT, TASK AREA & WORK UNIT NUMBERS NRL Problem R12-05 PE 62712N Task ZF12-100-001
11. CONTROLLING OFFICE NAME AND ADDRESS		12. REPORT DATE November 1977
		13. NUMBER OF PAGES 69
14. MONITORING AGENCY NAME & ADDRESS (if different from Controlling Office)		15. SECURITY CLASS. (of this report) UNCLASSIFIED
		15a. DECLASSIFICATION/DOWNGRADING SCHEDULE
16. DISTRIBUTION STATEMENT (of this Report) Approved for public release; distribution unlimited.		
17. DISTRIBUTION STATEMENT (of the abstract entered in Block 20, if different from Report)		
18. SUPPLEMENTARY NOTES		
19. KEY WORDS (Continue on reverse side if necessary and identify by block number) Transceiver                      Phase shifter Solid state                        Microwave Receiver                            Automatic network analyzer Transmitter                        Measurement, test and evaluation		
20. ABSTRACT (Continue on reverse side if necessary and identify by block number) Complexity of modern phased array radars requires that new high speed methods of microwave component test and evaluation be devised such that, not only is the specific device under test evaluated as to quality and accuracy, but also in terms of system errors, the total of all devices is evaluated in an appropriate statistical method to assure final use compatibility. This report summarizes the effort at Naval Research Laboratory, Washington, D.C. to devise such a computer controlled laboratory test and evaluation facility capable to measuring not only CW devices, such as receivers, but also pulse devices such as transmitters. More specifically, the program as devised to implement an all (Continues)		



20. Abstract (Continued)

solid state L-band transceiver module evaluation is described.

Samples of computer programs and special test equipment schematics are included along with samples of data printout.

ACCESSION NO.	
NTIS	White Section <input checked="" type="checkbox"/>
DDI	Buff Section <input type="checkbox"/>
UNANNOUNCED	<input type="checkbox"/>
JUSTIFICATION.....	
BY.....	
DISTRIBUTION/AVAILABILITY CODES	
Dist.	AVAIL. and/or SPECIAL
A	

**CONTENTS**

<b>INTRODUCTION .....</b>	<b>1</b>
<b>THE DEVICE UNDER TEST .....</b>	<b>1</b>
<b>THE MEASUREMENT PROGRAM .....</b>	<b>6</b>
<b>DATA PROCESSING AND OUTPUT .....</b>	<b>7</b>
<b>CONCLUSIONS .....</b>	<b>7</b>
<b>APPENDIX I .....</b>	<b>14</b>
<b>APPENDIX II .....</b>	<b>23</b>
<b>APPENDIX III .....</b>	<b>45</b>
<b>APPENDIX IV .....</b>	<b>60</b>

## A METHOD FOR AUTOMATIC TEST AND EVALUATION OF MICROWAVE TRANSCEIVERS AT L-BAND FREQUENCIES

### Introduction

The advent of the practical phased array radar introduced the need for complex testing and thorough statistical analysis into the microwave industry. The voluminous quantities of data required on each device coupled with the redundancy of devices used on even a single system made the use of automatic microwave test systems mandatory, not optional.

The long test and evaluation cycle required for acquiring large quantities of data coupled with the uniqueness of each device has in turn created a serious financial burden on most manufacturers who cannot justify the purchase and/or fabrication of such equipment based upon anticipated demands.

The gathering of data on a single device is only the first step in a chain of statistical analyses. Individual limits must be imposed upon each device produced to assure quality control but in a system using hundreds or even thousands of the same device (such as is experienced in phased arrays) then only the aggregate performance is important to the system. Thus through the test of individual devices, system performance can be predicted and as the data base is increased, the importance of individual parameters on the system can develop into higher quality and more cost effective products.

This report describes the effort expended at the Naval Research Laboratory in the attainment of an automatic test facility capable of acquiring individual device data and the reduction of such data into terms suitable for system statistics.

This effort has been concentrated primarily at L-band frequencies and on transmit/receive devices, the latest device being such a transceiver now in production by the General Electric Company, Aircraft Equipment Division, Utica, New York for the Naval Air Development Center, Warminster, Pennsylvania (Dr. J. Smith, Code 2040).

### The Device Under Test

In order to reduce the complex testing required to manageable proportions, it is necessary to specifically tailor the test program to the unique device under test and to eliminate operator interaction

Note: Manuscript submitted November 10, 1977.



or reduce this interaction to a minimum. Towards this goal a thorough understanding of the device parameters to be evaluated and the conditions of test is indicated as well as an understanding of microwave testing techniques.

The device that is being considered in this report is a transceiver, used in a phased array radar at L-band, under pulse transmit conditions. In addition to microwave circuitry such as circulators, switches, and amplifiers, the device employs a 5 bit (32 state) electronic phase shifter, and a 3 bit (8 state) electronic step attenuator. Within the transceiver structure is the necessary electronic circuitry to translate incoming digital signals into appropriate performance commands.

It is, therefore, necessary to gather performance data under the following test modes:

- transmit
- receive
- over frequency
- over phase
- over attenuation (receive only)
- over temperature
- over supply voltages
- over input power (transmit only)

In addition, a typical device may be required to operate under various combinations of PRF and pulse width during transmit which greatly adds to the amount of data required to verify system performance capability.

Referring to the above list the number of data points considered necessary and adequate for the transceiver amounted to 2304 for receive and 864 for transmit for each temperature/voltage combination during acceptance with a total of 20736 receive and 7776 transmitter data points per transceiver module during qualification.

It can therefore be seen that entering into such a test endeavor without an adequate test sequence and plan or without adequate test facilities can lead to chaos.

Microwave Tests. The number and kind of microwave measurements are quite limited but from these limited number of measurements much data can be extracted. In automatic microwave measurement, after appropriate calibration, it is possible to measure

- a. Amplitude and angle of reflected power
- b. Amplitude and angle of transmitted power

Many systems, such as the Hewlett-Packard Automatic Network Analyzer define a set of device S-parameters from which the typical RF terms can be derived. In addition, dependent on the type of device to



be evaluated, it is possible to vary the calibration model and therefore the correction factors applied to the device under test.

In each case, however, the four basic bits of information are used to derive all necessary data. VSWR is derived from the reflective properties. Gain (or loss) is derived from transmission magnitude and such properties as differential phase and differential attenuation are derived from various sets of transmission data. It is insufficient to just derive the S parameter values; it is necessary that data processing be incorporated into any program to permit evaluation.

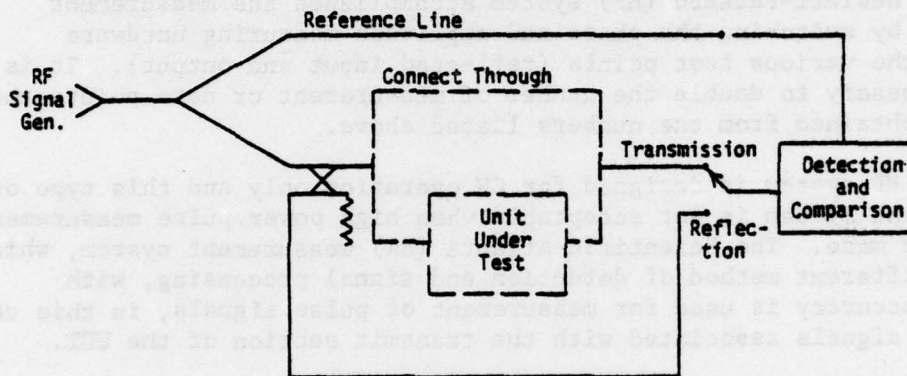

Fig. 1 - Test by comparison test method

The measurement system. Both microwave automatic measurement systems used for the measurements described in this report are similar in method, although quite diverse in design particulars. Referring to Figure 1, the RF signal is divided into two paths, one to be used as a reference, the other as a signal for the unit under test (UUT). In addition, the reflected wave at the input to the UUT is sampled.

To determine a complete set of S parameters, both phase and amplitude of the various signals must be known, first over all measurement frequencies under calibrate conditions with no UUT in the line from which system correction factors are determined and then repeated at the measurement frequencies with the UUT in the line.

The Hewlett-Packard (HP) system accomplishes the measurement sequence by switching the phase and amplitude measuring hardware between the various test points (reflected input and output). It is thus necessary to double the number of measurement or data points that must be obtained from the numbers listed above.

The HP system is designed for CW operation only and this type of measurement system is not acceptable when high power pulse measurements are to be made. The Scientific-Atlanta (SA) measurement system, which uses a different method of detection and signal processing, with reduced accuracy is used for measurement of pulse signals, in this case transmit signals associated with the transmit section of the UUT.

In addition, the Naval Research Laboratory has modified this equipment so that the input power can be leveled at each frequency to predetermined values for evaluation of such devices that are sensitive to input power especially those operating in a non-linear mode (class C transmit operation for the UUT). Also, the addition of pulse peak power meters, to measure forward power before and after the device under test and the input reflected power permits the measurement of powers by sampling (80 nsec) the pulse power. The sampling window can be moved through the RF pulse time and does not operate on the basis of averaging techniques as does the SA equipment.

Transmission and reflection properties of the UUT are measured simultaneously with this equipment, therefore, switching is not required. It is necessary, however, to measure at each data point, a series of five measurements, which are averaged to reduce instantaneous errors and eliminate erroneous measurements. This then means that the number of sequential measurements becomes 80,352 for qualification of each UUT and 8,928 for acceptance.

In addition to the signal measurement hardware, there is associated with the overall control system, a set of control hardware used with the UUT, and redesigned and/or modified as required for each device and test plan that has for its prime function control of the UUT. This control includes the necessary switching of the various module functions

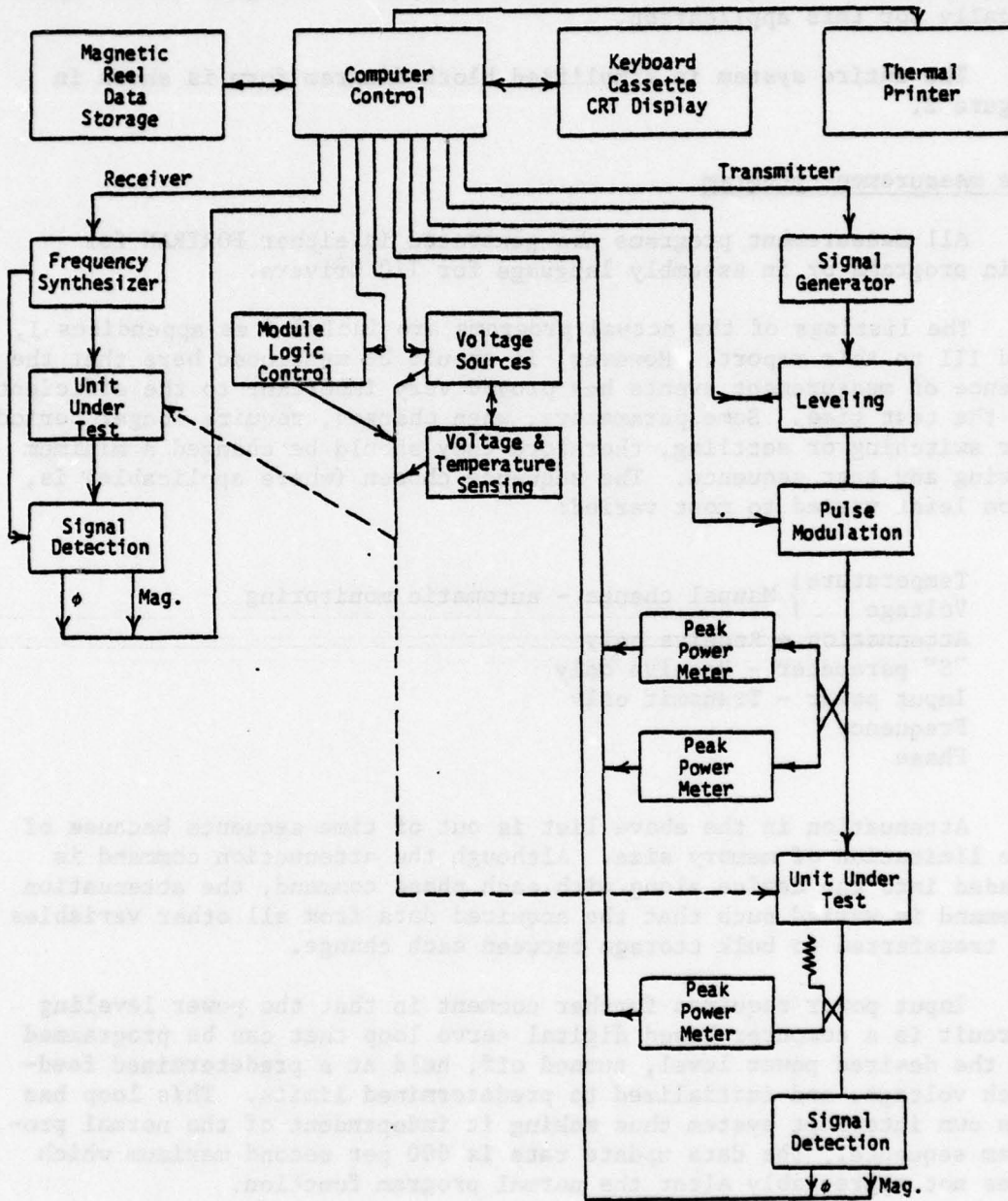

Fig. 2 - Simplified system block diagram



such as transmit/receive, phase shift and attenuation, by the generation of the necessary code sequences under computer control and also the generation and control and/or monitoring of the various supply voltages and operating temperatures. See appendix IV for detail schematics of this special test equipment and other equipments designed at NRL specifically for this application.

The entire system in simplified block diagram form is shown in Figure 2.

#### The measurement program

All measurement programs are generated in either FORTRAN for main programs or in assembly language for I/O drivers.

The listings of the actual programs are included as appendices I, II, and III to this report. However, it should be mentioned here that the sequence of measurement events has proved very important to the efficient use of the test time. Some parameters, when changed, require longer periods for switching or settling, therefore they should be changed a minimum during any test sequence. The sequence chosen (where applicable) is, from least varied to most varied:

Temperature	}	Manual change - automatic monitoring
Voltage		
Attenuation		- Receive only
"S" parameter		- Receive only
Input power		- Transmit only
Frequency		
Phase		

Attenuation in the above list is out of time sequence because of the limitation of memory size. Although the attenuation command is loaded into the device along with each phase command, the attenuation command is varied such that the acquired data from all other variables is transferred to bulk storage between each change.

Input power requires further comment in that the power leveling circuit is a computer based digital servo loop that can be programmed to the desired power level, turned off, held at a predetermined feedback voltage, and initialized to predetermined limits. This loop has its own interrupt system thus making it independent of the normal program sequence. The data update rate is 600 per second maximum which does not appreciably alter the normal program function.

Programs and any other special command functions are entered by way of keyboard or magnetic tape cassette. Data is output to reel type magnetic tape. Each file of data first references a serial number followed



by pertinent test parameters so that a tape can be easily searched for the desired file. The appendices include program listings for searching transmit or receive data tapes, extracting the desired data and processing the data in a similar manner to the main program.

#### Data processing and output

It is desirable to store the data obtained in raw form on magnetic tape for future processing and generation of overall statistics but it is likewise necessary for immediate use that a summary listing be made available. Many forms could be generated including curves and histograms but the quantity of print-out can rapidly reach uncontrollable proportions.

For this reason it was decided that the raw data as delivered by the test system would be processed into the various specification parameters and presented in tabular form. Because of the statistical nature of the application for the units to be evaluated much of the data is printed out in terms of statistical information.

In addition a keyboard switch option was included in the program that generates a long form print out where in addition to the summary data, information at each frequency-phase state is given. This long form print out is forced when power output under transmit test conditions reaches a level that causes large measurement errors (i.e. 0 dBm) so that the operator is immediately aware of the type of error and then can properly evaluate the statistical parameters.

A listing of the short form print-out is given in Figure 3 and the long form is given in Figure 4.

Conclusions. With the complexity of test and the number of data points necessary for a meaningful statistical analysis, the use of manual test equipment requiring much operator interaction is prohibited.

Thus for production components, or those that are to be produced in quantity where repeated similar tests are to be performed, the computer based test facility with data processing and storage is indicated. Not only can immediate data be obtained but the stored data can be processed at a later date in ways specifically meaningful to the end system use as well as in the form of useful statistics on classes of devices.

SER.NO. 001  
 DATE: MAY 20, 1977  
 VOLT1=-11.090  
 TEMP1= 24.9DEG.C  
 TAPE TEST, AS CALIBRATED XXX

RECEIVER  
 VOLT2= 23.890  
 TEMP2= -24.9DEG.C

ATTENUATION= 2DB.

FREQ.	1235	1260	1280	1295	1300	1305	1320	1340	1365
VSWR MAX	1.04	1.04	1.04	1.04	1.04	1.04	1.05	1.05	1.05
VSWR MEAN	1.04	1.04	1.04	1.04	1.04	1.04	1.05	1.05	1.05
MAX-PH-ER	-349.	-349.	-349.	-349.	-349.	-349.	-349.	-349.	-349.
RMS-PH-ER	203.0	203.0	203.0	203.0	203.0	203.0	203.0	202.9	203.0
MAX-GN-DB	.0	.0	.0	-.0	-.0	-.0	-.0	-.0	-.0
MIN-GN-DB	.0	-.0	-.0	-.0	-.0	-.0	-.0	-.0	-.0
INS PHAS	-18.	-18.	-19.	-19.	-19.	-19.	-19.	-19.	-20.
OVERALL MEAN GAIN=	-.0DB.								
STD. DEVIATION IN OVERALL GAIN=	-58.3DB.								

SER.NO. TEST  
 DATE: MAY 17, 1977  
 VOLT1=-11.145  
 TEMP1= 23.9DEG.C  
 NONE

TRANSMITTER  
 VOLT2= 24.150  
 TEMP2= -34.6DEG.C

INPUT POWER=24.8DBM.

\*FMT #3

FREQ.	1235	1260	1280	1295	1300	1305	1320	1340	1365
VSWR MAX	#####	#####	#####	#####	#####	#####	#####	#####	#####
VSWR MEAN	#####	#####	#####	#####	#####	#####	#####	#####	#####
MAX-PH-ER	-349.	-349.	-349.	-304.	-259.	-349.	-349.	-349.	-349.
RMS-PH-ER	203.0	202.9	202.9	165.6	130.8	203.0	203.0	203.1	203.0
MAX-PWR-W	.0	.0	.0	.0	.0	.0	.0	.0	.0
MIN-PWR-W	.0	.0	.0	.0	.0	.0	.0	.0	.0
INS PHAS	.	.	.	.	.	360.	360.	360.	360.
OVERALL MEAN PEAK POWER=	.0WATTS								
STD. DEVIATION IN OVERALL PEAK POWER=	.0WATTS								

Fig. 3 - Short form printout for transmitter and receiver sections of transceiver

SER.NO. TEST  
 DATE: MAY 17, 1977  
 VOLT1=-11.145  
 TEMP1= 23.9DEG.C  
 NONE

TRANSMITTER  
 VOLT2= 24.150  
 TEMP2= -34.6DEG.C

INPUT POWER=24.8DBM.

FREQ.	1235	1260	1280	1295	1300	1305	1320	1340	1365
.00 DEG.									
VSWR	#####	#####	#####	#####	#####	#####	#####	#####	#####
MAX-PWR-W	.0	.0	.0	.0	.0	.0	.0	.0	.0
IPHS	.	.	.	.	.	360.	360.	360.	360.
11.25 DEG.									
VSWR	#####	#####	#####	#####	#####	#####	#####	#####	#####
MAX-PWR-W	.0	.0	.0	.0	.0	.0	.0	.0	.0
DEL PHASE	-.0	.0	-.0	.0	.0	-.0	.0	-.1	-.1
22.50 DEG.									
VSWR	#####	#####	#####	#####	#####	#####	#####	#####	#####
MAX-PWR-W	.0	.0	.0	.0	.0	.0	.0	.0	.0
DEL PHASE	-.1	.0	.0	.0	-.0	-.0	.0	-.0	-.1
33.75 DEG.									
VSWR	#####	#####	#####	#####	#####	#####	#####	#####	#####
MAX-PWR-W	.0	.0	.0	.0	.0	.0	.0	.0	.0
DEL PHASE	-.0	.0	.0	.0	.0	.0	.0	.0	.0
45.00 DEG.									
VSWR	#####	#####	#####	#####	#####	#####	#####	#####	#####
MAX-PWR-W	.0	.0	.0	.0	.0	.0	.0	.0	.0
DEL PHASE	-.0	.0	.1	.0	.0	.0	.0	-.0	-.0
56.25 DEG.									
VSWR	#####	#####	#####	#####	#####	#####	#####	#####	#####
MAX-PWR-W	.0	.0	.0	.0	.0	.0	.0	.0	.0
DEL PHASE	-.0	.0	.0	.0	-.0	-.0	.0	.0	-.0
67.50 DEG.									
VSWR	#####	#####	#####	#####	#####	#####	#####	#####	#####
MAX-PWR-W	.0	.0	.0	.0	.0	.0	.0	.0	.0
DEL PHASE	-.1	.0	.0	.0	.0	.0	-.1	-.0	-.1
78.75 DEG.									
VSWR	#####	#####	#####	#####	#####	#####	#####	#####	#####
MAX-PWR-W	.0	.0	.0	.0	.0	.0	.0	.0	.0
DEL PHASE	-.0	.0	.0	-.0	-.0	-.0	-.0	-.0	-.0
90.00 DEG.									
VSWR	#####	#####	#####	#####	#####	#####	#####	#####	#####
MAX-PWR-W	.0	.0	.0	.0	.0	.0	.0	.0	.0
DEL PHASE	.0	.0	-.0	.0	-.0	-.0	-.0	-.0	-.1
101.25 DEG.									
VSWR	#####	#####	#####	#####	#####	#####	#####	#####	#####
MAX-PWR-W	.0	.0	.0	.0	.0	.0	.0	.0	.0
DEL PHASE	-.0	.0	.0	.0	.0	.0	-.0	-.1	-.0
112.50 DEG.									
VSWR	#####	#####	#####	#####	#####	#####	#####	#####	#####
MAX-PWR-W	.0	.0	.0	.0	.0	.0	.0	.0	.0
DEL PHASE	-.0	.0	.0	.0	.0	-.0	-.0	-.1	-.0
123.75 DEG.									
VSWR	#####	#####	#####	#####	#####	#####	#####	#####	#####
MAX-PWR-W	.0	.0	.0	.0	.0	.0	.0	.0	.0
DEL PHASE	-.0	.0	.0	.0	.0	.0	-.0	-.1	-.0
135.00 DEG.									
VSWR	#####	#####	#####	#####	#####	#####	#####	#####	#####
MAX-PWR-W	.0	.0	.0	.0	.0	.0	.0	.0	.0
DEL PHASE	.0	.0	.0	-.0	-.0	.0	-.0	-.1	-.1

Fig. 4 - Long form data printout for transmitter and receiver sections of transceiver module (Continues)



146.25 DEG.									
VSWR	#####	#####	#####	#####	#####	#####	#####	#####	#####
MAX-PWR-W	.0	.0	.0	.0	.0	.0	.0	.0	.0
DEL PHASE	-.0	.0	.0	.0	.0	-.0	.0	-.1	-.1
157.50 DEG.									
VSWR	#####	#####	#####	#####	#####	#####	#####	#####	#####
MAX-PWR-W	.0	.0	.0	.0	.0	.0	.0	.0	.0
DEL PHASE	-.0	.0	.0	.0	.0	-.0	-.1	-.2	-.1
168.75 DEG.									
VSWR	#####	#####	#####	#####	#####	#####	#####	#####	#####
MAX-PWR-W	.0	.0	.0	.0	.0	.0	.0	.0	.0
DEL PHASE	-.0	.0	-.0	.0	-.0	-.0	-.0	-.2	-.1
180.00 DEG.									
VSWR	#####	#####	#####	#####	#####	#####	#####	#####	#####
MAX-PWR-W	.0	.0	.0	.0	.0	.0	.0	.0	.0
DEL PHASE	-.1	.0	.0	-.0	.0	.0	-.0	-.2	-.2
191.25 DEG.									
VSWR	#####	#####	#####	#####	#####	#####	#####	#####	#####
MAX-PWR-W	.0	.0	.0	.0	.0	.0	.0	.0	.0
DEL PHASE	-.0	.0	.0	-.0	.0	-.0	-.0	-.2	-.1
202.50 DEG.									
VSWR	#####	#####	#####	#####	#####	#####	#####	#####	#####
MAX-PWR-W	.0	.0	.0	.0	.0	.0	.0	.0	.0
DEL PHASE	-.0	.0	.0	.0	.0	-.0	-.0	-.2	-.1
213.75 DEG.									
VSWR	#####	#####	#####	#####	#####	#####	#####	#####	#####
MAX-PWR-W	.0	.0	.0	.0	.0	.0	.0	.0	.0
DEL PHASE	.0	.0	.0	.0	-.0	-.0	-.0	-.2	-.0
225.00 DEG.									
VSWR	#####	#####	#####	#####	#####	#####	#####	#####	#####
MAX-PWR-W	.0	.0	.0	.0	.0	.0	.0	.0	.0
DEL PHASE	-.0	.0	.0	.0	.0	-.1	-.0	-.2	-.1
236.25 DEG.									
VSWR	#####	#####	#####	#####	#####	#####	#####	#####	#####
MAX-PWR-W	.0	.0	.0	.0	.0	.0	.0	.0	.0
DEL PHASE	-.0	.0	.0	.0	-.0	-.1	-.0	-.2	.0
247.50 DEG.									
VSWR	#####	#####	#####	#####	#####	#####	#####	#####	#####
MAX-PWR-W	.0	.0	.0	.0	.0	.0	.0	.0	.0
DEL PHASE	-.0	.0	.1	-.0	.0	.0	-.0	-.2	-.1
258.75 DEG.									
VSWR	#####	#####	#####	#####	#####	#####	#####	#####	#####
MAX-PWR-W	.0	.0	.0	.0	.0	.0	.0	.0	.0
DEL PHASE	-.1	.0	-.0	.0	.0	.0	.0	-.2	.0
270.00 DEG.									
VSWR	#####	#####	#####	#####	#####	#####	#####	#####	#####
MAX-PWR-W	.0	.0	.0	.0	.0	.0	.0	.0	.0
DEL PHASE	-.0	.0	.1	.0	360.0	.0	-.0	-.1	-.0
281.25 DEG.									
VSWR	#####	#####	#####	#####	#####	#####	#####	#####	#####
MAX-PWR-W	.0	.0	.0	.0	.0	.0	.0	.0	.0
DEL PHASE	-.1	.0	-.0	.0	360.0	-.1	.0	-.2	.0
292.50 DEG.									
VSWR	#####	#####	#####	#####	#####	#####	#####	#####	#####
MAX-PWR-W	.0	.0	.0	.0	.0	.0	.0	.0	.0
DEL PHASE	-.0	.0	.0	-.0	360.0	-.0	-.1	-.2	-.1
303.75 DEG.									
VSWR	#####	#####	#####	#####	#####	#####	#####	#####	#####
MAX-PWR-W	.0	.0	.0	.0	.0	.0	.0	.0	.0
DEL PHASE	.0	.0	.0	-.0	360.0	-.0	.0	-.1	-.0

Fig. 4 (Continued) - Long form data printout for transmitter and receiver sections of transceiver module



SER.NO. 001  
 DATE: MAY 20, 1977  
 VOLT1=-11.090  
 TEMP1= 24.9DEG.C  
 TAPE TEST, AS CALIBRATED XXX

RECEIVER  
 VOLT2= 23.890  
 TEMP2= -24.9DEG.C

ATTENUATION= 2DB.

FREQ.	1235	1260	1280	1295	1300	1305	1320	1340	1365
.00 DEG.									
VSWR	1.04	1.04	1.04	1.04	1.04	1.04	1.05	1.05	1.05
GAIN-DB	.0	-.0	-.0	-.0	-.0	-.0	-.0	-.0	-.0
IPHS	-18.	-18.	-19.	-19.	-19.	-19.	-19.	-19.	-20.
11.25 DEG.									
VSWR	1.04	1.04	1.04	1.04	1.04	1.04	1.05	1.05	1.05
GAIN-DB	.0	.0	-.0	-.0	-.0	-.0	-.0	-.0	-.0
DEL PHASE	-.0	-.0	-.1	-.0	.0	.0	.0	.0	.0
22.50 DEG.									
VSWR	1.04	1.04	1.04	1.04	1.04	1.04	1.05	1.05	1.05
GAIN-DB	.0	-.0	.0	-.0	-.0	-.0	-.0	-.0	-.0
DEL PHASE	-.0	-.0	-.0	-.0	.0	-.0	.0	.0	.0
33.75 DEG.									
VSWR	1.04	1.04	1.04	1.04	1.04	1.04	1.05	1.05	1.05
GAIN-DB	.0	.0	.0	-.0	-.0	-.0	-.0	-.0	-.0
DEL PHASE	.0	-.0	-.1	-.0	-.0	-.0	.0	.0	.0
45.00 DEG.									
VSWR	1.04	1.04	1.04	1.04	1.04	1.04	1.05	1.05	1.05
GAIN-DB	.0	-.0	.0	-.0	-.0	-.0	-.0	-.0	-.0
DEL PHASE	-.0	-.0	-.0	-.0	.0	.0	.0	.0	.0
56.25 DEG.									
VSWR	1.04	1.04	1.04	1.04	1.04	1.04	1.05	1.05	1.05
GAIN-DB	.0	-.0	.0	-.0	-.0	-.0	-.0	-.0	-.0
DEL PHASE	.0	-.0	-.0	-.0	-.0	-.0	-.0	.0	.0
67.50 DEG.									
VSWR	1.04	1.04	1.04	1.04	1.04	1.04	1.05	1.05	1.05
GAIN-DB	.0	-.0	.0	-.0	-.0	-.0	-.0	-.0	-.0
DEL PHASE	-.0	-.0	-.0	-.0	.0	.0	.0	.0	.0
78.75 DEG.									
VSWR	1.04	1.04	1.04	1.04	1.04	1.04	1.05	1.05	1.05
GAIN-DB	.0	-.0	-.0	-.0	-.0	-.0	-.0	-.0	-.0
DEL PHASE	-.0	-.0	-.1	-.0	.0	.0	.0	.0	.0
90.00 DEG.									
VSWR	1.04	1.04	1.04	1.04	1.04	1.04	1.05	1.05	1.05
GAIN-DB	.0	-.0	.0	-.0	-.0	-.0	-.0	-.0	-.0
DEL PHASE	-.0	-.0	-.0	-.0	.0	.0	.0	.0	.0
101.25 DEG.									
VSWR	1.04	1.04	1.04	1.04	1.04	1.04	1.05	1.05	1.05
GAIN-DB	.0	.0	.0	-.0	-.0	-.0	-.0	-.0	-.0
DEL PHASE	-.0	-.0	-.0	-.0	-.0	.0	.0	.0	.0
112.50 DEG.									
VSWR	1.04	1.04	1.04	1.04	1.04	1.04	1.05	1.05	1.05
GAIN-DB	.0	-.0	-.0	-.0	-.0	-.0	-.0	-.0	-.0
DEL PHASE	-.0	-.0	-.1	-.0	.0	-.0	-.0	.0	.0
123.75 DEG.									
VSWR	1.04	1.04	1.04	1.04	1.04	1.04	1.05	1.05	1.05
GAIN-DB	.0	.0	-.0	-.0	-.0	-.0	-.0	-.0	-.0
DEL PHASE	-.0	-.0	-.0	-.0	.0	.0	-.0	.0	.0
135.00 DEG.									
VSWR	1.04	1.04	1.04	1.04	1.04	1.04	1.05	1.05	1.05
GAIN-DB	.0	-.0	.0	-.0	-.0	-.0	-.0	-.0	-.0

Fig. 4 (Continued) - Long form data printout for transmitter and receiver sections of transceiver module

DEL PHASE	-.0	-.0	-.1	-.0	-.0	-.0	.0	.0	.0
146.25 DEG.									
VSWR	1.04	1.04	1.04	1.04	1.04	1.04	1.05	1.05	1.05
GAIN-DB	.0	.0	.0	-.0	-.0	-.0	-.0	-.0	-.0
DEL PHASE	-.0	-.0	-.0	-.0	-.0	.0	-.0	.0	.0
157.50 DEG.									
VSWR	1.04	1.04	1.04	1.04	1.04	1.04	1.05	1.05	1.05
GAIN-DB	.0	-.0	-.0	-.0	-.0	-.0	-.0	-.0	-.0
DEL PHASE	-.0	-.0	-.1	-.0	.0	.0	.0	.0	.0
168.75 DEG.									
VSWR	1.04	1.04	1.04	1.04	1.04	1.04	1.05	1.05	1.05
GAIN-DB	.0	.0	-.0	-.0	-.0	-.0	-.0	-.0	-.0
DEL PHASE	-.0	-.0	-.0	-.0	-.0	.0	-.0	.0	.0
180.00 DEG.									
VSWR	1.04	1.04	1.04	1.04	1.04	1.04	1.05	1.05	1.05
GAIN-DB	.0	.0	-.0	-.0	-.0	-.0	-.0	-.0	-.0
DEL PHASE	-.0	-.0	-.0	-.0	.0	-.0	-.0	.0	.0
191.25 DEG.									
VSWR	1.04	1.04	1.04	1.04	1.04	1.04	1.05	1.05	1.05
GAIN-DB	.0	.0	-.0	-.0	-.0	-.0	-.0	-.0	-.0
DEL PHASE	-.0	-.0	-.1	-.0	.0	.0	.0	.0	.0
202.50 DEG.									
VSWR	1.04	1.04	1.04	1.04	1.04	1.04	1.05	1.05	1.05
GAIN-DB	.0	.0	-.0	-.0	-.0	-.0	-.0	-.0	-.0
DEL PHASE	-.0	-.0	-.1	-.0	.0	-.0	.0	.0	.0
213.75 DEG.									
VSWR	1.04	1.04	1.04	1.04	1.04	1.04	1.05	1.05	1.05
GAIN-DB	.0	.0	-.0	-.0	-.0	-.0	-.0	-.0	-.0
DEL PHASE	-.0	-.0	-.1	-.0	.0	-.0	-.0	.0	.0
225.00 DEG.									
VSWR	1.04	1.04	1.04	1.04	1.04	1.04	1.05	1.05	1.05
GAIN-DB	.0	-.0	-.0	-.0	-.0	-.0	-.0	-.0	-.0
DEL PHASE	-.0	-.0	-.1	-.0	-.0	-.0	.0	.0	.0
236.25 DEG.									
VSWR	1.04	1.04	1.04	1.04	1.04	1.04	1.05	1.05	1.05
GAIN-DB	.0	.0	.0	-.0	-.0	-.0	-.0	-.0	-.0
DEL PHASE	-.0	-.0	-.0	-.0	.0	-.0	-.0	.0	.0
247.50 DEG.									
VSWR	1.04	1.04	1.04	1.04	1.04	1.04	1.05	1.05	1.05
GAIN-DB	.0	-.0	-.0	-.0	-.0	-.0	-.0	-.0	-.0
DEL PHASE	-.0	-.0	.0	-.0	.0	.0	.0	.0	.0
258.75 DEG.									
VSWR	1.04	1.04	1.04	1.04	1.04	1.04	1.05	1.05	1.05
GAIN-DB	.0	-.0	.0	-.0	-.0	-.0	-.0	-.0	-.0
DEL PHASE	-.0	-.0	-.0	-.0	-.0	-.0	.0	.0	.0
270.00 DEG.									
VSWR	1.04	1.04	1.04	1.04	1.04	1.04	1.05	1.05	1.05
GAIN-DB	.0	-.0	.0	-.0	-.0	-.0	-.0	-.0	-.0
DEL PHASE	-.0	-.0	-.0	-.0	-.0	-.0	.0	.0	.0
281.25 DEG.									
VSWR	1.04	1.04	1.04	1.04	1.04	1.04	1.05	1.05	1.05
GAIN-DB	.0	-.0	-.0	-.0	-.0	-.0	-.0	-.0	-.0
DEL PHASE	-.0	-.0	-.1	-.0	-.0	-.0	-.0	.0	.0
292.50 DEG.									
VSWR	1.04	1.04	1.04	1.04	1.04	1.04	1.05	1.05	1.05
GAIN-DB	.0	-.0	-.0	-.0	-.0	-.0	-.0	-.0	-.0
DEL PHASE	-.0	-.0	-.1	-.0	-.0	-.0	-.0	.0	.0
303.75 DEG.									
VSWR	1.04	1.04	1.04	1.04	1.04	1.04	1.05	1.05	1.05
GAIN-DB	.0	-.0	-.0	-.0	-.0	-.0	-.0	-.0	-.0

Fig. 4 (Continued) - Long form data printout for transmitter and receiver sections of transceiver module

DEL PHASE	-.0	-.0	-.1	-.0	-.0	-.0	.0	-.0	.0
315.00 DEG.									
VSWR	1.04	1.04	1.04	1.04	1.04	1.04	1.05	1.05	1.05
GAIN-DB	.0	.0	-.0	-.0	-.0	-.0	-.0	-.0	-.0
DEL PHASE	-.0	-.0	.0	-.1	.0	.0	.0	.0	.0
326.25 DEG.									
VSWR	1.04	1.04	1.04	1.04	1.04	1.04	1.05	1.05	1.05
GAIN-DB	.0	-.0	.0	-.0	-.0	-.0	-.0	-.0	-.0
DEL PHASE	-.0	-.0	-.0	-.0	.0	-.0	.0	.0	.0
337.50 DEG.									
VSWR	1.04	1.04	1.04	1.04	1.04	1.04	1.05	1.05	1.05
GAIN-DB	.0	.0	.0	-.0	-.0	-.0	-.0	-.0	-.0
DEL PHASE	-.0	-.0	-.0	-.0	.0	.0	.0	-.0	.0
348.75 DEG.									
VSWR	1.04	1.04	1.04	1.04	1.04	1.04	1.05	1.05	1.05
GAIN-DB	.0	-.0	.0	-.0	-.0	-.0	-.0	-.0	-.0
DEL PHASE	-.0	-.0	-.0	-.0	-.0	.0	-.0	.0	.0

Fig. 4 (Continued) - Long form data printout for transmitter and receiver sections of transceiver module



## APPENDIX I

### Data processing programs:

These programs are intended for locating data already obtained and stored on magnetic tape. The desired file is called by inputting the serial number and attenuation or input power level. The output processed data is in the form of Figures 3 and 4 of this report.



```

PROGRAM RDRCV
  DIMENSION NDATE(10),NSER(10),LTL1(20),CM(64,9),GMAG(32,9),
  1GMAG(32,9),VMAG(32,9),AMAXV(9),AMENV(9),AMAXP(9),RMSPH(9),
  2DEGMX(9),DBGMI(9),BANG(9),F(9),VANG(32,9),VMG1(288),
  3VAG(288),GAG(288),GNG(288),TEMP8(9),TEMP9(9),ISER(10)
C
C
C
C
C *****
C
C   THIS PROGRAM SEARCHES MAG. TAPE FOR DATA WITH MATCHING
C   SERIAL NUMBER AND ATTENUATION.
C   RECEIVER DATA ONLY.
C   OUTPUT DATA TO VERSATEC IN BOTH LONG AND SHORT FORMAT
C   AS PER NADC1.
C
C   REV. C   MAY 20,1977
C   L. LAVEDAN
C *****
C
C   F(1)=1235.
C   F(2)=1260.
C   F(3)=1280.
C   F(4)=1295.
C   F(5)=1300.
C   F(6)=1305.
C   F(7)=1320.
C   F(8)=1340.
C   F(9)=1365.
C
C   CALL CLEAR(0)
C   WRITE(9,100)
C 100 FORMAT("PROGRAM FOR LOCATING AND PROCESSING RECEIVER"/
C 110X," DATA STORED ON MAG. TAPE"//
C 2"PLEASE SELECT TAPE AND PUT SYSTEM ON LINE")
C
C   CALL PAUSE
C   REWIND 18
C 110 CALL CLEAR(0)
C   WRITE(9,120)
C 120 FORMAT("INPUT SERIAL NUMBER+")
C   READ(8,130)(ISER(I),I=1,10)
C 130 FORMAT(10A2)
C   WRITE(9,131)
C 131 FORMAT("INPUT ATTENUATION+")
C   READ(8,*) NTTNS
C 135 READ(18,140)
C 140 FORMAT(I1)
C   IF(IEOF(18)) 150,135
C 150 READ(18,170)LET1,(NSER(I),I=1,10),ITTN3,(NDATE(I),
C 1I=1,10),VOLT1,VOLT2,TEMP1,TEMP2,(LTL1(I),I=1,20)
C 170 FORMAT(A1,10A2,I2,10A2,2F7.3,2F7.2,20A2)
C   IF(IEOF(18))200,210
C 210 DO 500 I=1,10
C   IF(ISER(I)-NSER(I)) 135,500,135

```

```

500 CONTINUE
   IF (NTTN3-ITTN3) 135,1000,135
C
C   CORRECT SER NO CONTINUES
C
1000 READ(18,1001) (VMG1(I), I=1,288)
      READ(18,1001) (VAG(I), I=1,288)
      READ(18,1001) (GAG(I), I=1,288)
      READ(18,1001) (GNG(I), I=1,288)
1001 FORMAT (28(10E12.7/)10E12.7)
C
C
C
C   ORDER PHASE STARTING WITH GANG(1,1)
C
      CALL PHORD(GANG(1,1))
      DO 2060 J=2,9
2030 IF (GANG(1,J-1)-GANG(1,J)+90.0) 2040,2040,2050
2040 GANG(1,J)=GANG(1,J)-360.0
      GO TO 2030
2050 CALL PHORD(GANG(1,J))
2060 CONTINUE
C
C   PROCESS DATA AND PRINT OUT ON VERSATEC
C
C   SET SUM GAIN TO 0
      SUMG=0.0
C   SET SUM(GAIN)2 TO 0
      SUMG2=0
C
C   DO 2100 II=1,9
C   INITIALIZE VALUES TO FIRST PHASE STATE
      GMAX=GMAG(1,II)
      GMIN=GMAG(1,II)
      VMAX=VMAG(1,II)
      VAVG=VMAX
      PH0=GANG(1,II)
      PHMAX=0.0
      SUMP2=PHMAX
      SUMG=SUMG+GMAG(1,II)
      SUMG2=SUMG2+GMAG(1,II)*GMAG(1,II)
C
C   PHASE LOOP
      DO 2150 IP=2,32
C   DETERMINE REFLECTION COEFF MAX
      IF (VMAG(IP,II)-VMAX) 2070,2070,2065
2065 VMAX=VMAG(IP,II)
C   DETERMINE SUM REF. COEFF.
2070 VAVG=VAVG+VMAG(IP,II)
C   DETERMINE VOLTAGE GAIN MAX
      IF (GMAG(IP,II)-GMAX) 2080,2080,2075
2075 GMAX=GMAG(IP,II)
C   DETERMINE VOLTAGE GAIN MIN
2080 IF (GMIN-GMAG(IP,II)) 2090,2090,2085
2085 GMIN=GMAG(IP,II)
C   DETERMINE SUM OF VOLT GAIN
2090 SUMG=SUMG+GMAG(IP,II)

```

```

C      DETERMINE SUM(VOLT GAIN)↑2
      SUMG2=SUMG2+GMAG(IP,II)*GMAG(IP,II)
C      DETERMINE DELTA PHASE
      DELP=PH0-GANG(IP,II)
C      DETERMINE DELTA PHASE ERROR
      DDELP=DELP-(11.25*FLOAT(IP-1))
C      DETERMINE DEL PHAS ERR MAX
      IF(ABS(DDELP)-ABS(PHMAX)) 2150,2150,2095
2095 PHMAX=DDELP
C      DETERMINE SUM(DEL PHAS ERR)↑2
      SUMP2 = SUMP2 + DDELP*DDELP
C
C 2150 CONTINUE
C      ON A PER FREQ BASIS-----
C      CONVERT MAX RHO TO VSWR MAX
      AMAXV(II)=(1.0+VMAX)/(1.0-VMAX)
C      CONVERT AVG RHO TO MEAN VSWR
      AMENV(II)=(1.0+(VAVG/32.0))/(1.0-(VAVG/32.0))
C      CONVERT MAX PHASE
      AMAXP(II)=PHMAX
C      CONVERT RMS PHASE
      RMSPH(II)=SQRT(SUMP2/32.0)
C      CONVERT VOLT GAIN MAX TO MAX GAIN DB
      DBGMX(II)=20.*ALOG(GMAX)/ALOG(10.0)
C      CONVERT VOLT GAIN MIN TO MIN GAIN DB
      DBGMI(II)=20.*ALOG(GMIN)/ALOG(10.0)
C
C 2100 CONTINUE
C      CONVERT TO MEAN GAIN
      DBGME=20.*ALOG(SUMG/288.0)/ALOG(10.0)
C      CONVERT TO RMS GAIN
      RMSG=20.*ALOG(SQRT((SUMG2-(SUMG*SUMG/288.0))/288.0))/
1ALOG(10.0)
C
C      CALL CLEAR(0)
      WRITE(11,2999)
2999 FORMAT(10(/))
C
3000 WRITE(11,3005)(NSER(I),I=1,10)
3005 FORMAT("SER.NO. ",10A2,5X,"RECEIVER")
      WRITE(11,3010)(NDATE(I),I=1,10)
3010 FORMAT("DATE: ",10A2)
      WRITE(11,3015)VOLT1,VOLT2
3015 FORMAT("VOLT1=",F7.3,20X,"VOLT2=",F7.3)
      WRITE(11,3020)TEMP1,TEMP2
3020 FORMAT("TEMP1=",F7.1,"DEG.C",16X,"TEMP2=",F7.1,"DEG.C")
      WRITE(11,3025)(LTL1(I),I=1,20)
3025 FORMAT(20A2/)
      WRITE(11,3030)ITTN3
3030 FORMAT("ATTNUATION=",I2,"DB."/)
      WRITE(11,3035)(F(I),I=1,9)
3035 FORMAT("FREQ.",3X,9(2X,F4.0))
      WRITE(11,3040)(AMAXV(I),I=1,9)
3040 FORMAT("VSWR MAX ",9(X,F5.2))
      WRITE(11,3045)(AMENV(I),I=1,9)
3045 FORMAT("VSWR MEAN",9(X,F5.2))
      WRITE(11,3050)(AMAXP(I),I=1,9)

```



```

3050 FORMAT("MAX-PH-ER",9(X,F5.1))
WRITE(11,3055)(RMSPH(I),I=1,9)
3055 FORMAT("RMS-PH-ER",9(X,F5.1))
WRITE(11,3060)(DBGMX(I),I=1,9)
3060 FORMAT("MAX-GN-DB",9(X,F5.1))
WRITE(11,3065)(DBGMI(I),I=1,9)
3065 FORMAT("MIN-GN-DB",9(X,F5.1))
WRITE(11,3070)(GANG(1,I),I=1,9)
3070 FORMAT("INS PHAS ",9(X,F5.0))
WRITE(11,3075)DBGME
3075 FORMAT("OVERALL MEAN GAIN=",F5.1,"DB.")
WRITE(11,3080)RMSG
3080 FORMAT("STD. DEVIATION IN OVERALL GAIN=",F6.1,"DB.")
CALL PAGE
4005 WRITE(11,3005)(NSER(I),I=1,10)
WRITE(11,3010)(NDATE(I),I=1,10)
WRITE(11,3015)VOLT1,VOLT2
WRITE(11,3020)TEMP1,TEMP2
WRITE(11,3025)(LTL1(I),I=1,20)
WRITE(11,3030)ITTN3
WRITE(11,3035)(F(I),I=1,9)

```

C  
C

```

DO 4100 I=1,32
DO 4101 J=1,9
TEMP9(J)=(1.+VMAG(I,J))/(1.-VMAG(I,J))
TEMP8(J)=20.*ALOG(GMAG(I,J))/ALOG(10.0)
4101 CONTINUE
BIT=11.25*FLOAT(I-1)
WRITE(11,4102) BIT
4102 FORMAT(" ",F6.2," DEG.")
WRITE(11,4105)(TEMP9(J),J=1,9)
4105 FORMAT("VSWR",5X,9(X,F5.2))
WRITE(11,4110)(TEMP8(J),J=1,9)
4110 FORMAT("GAIN-DB",2X,9(X,F5.1))
IF(I-1) 4115,4115,4120
4115 WRITE(11,4125)(GANG(1,J),J=1,9)
4125 FORMAT("IPHS",5X,9(X,F5.0))
GO TO 4100
4120 DO 4126 L=1,9
BANG(L)=GANG(1,L)-GANG(I,L)
4126 CONTINUE
WRITE(11,4130)(BANG(J),J=1,9)
4130 FORMAT("DEL PHASE",9(X,F5.1))

```

C

```

4100 CONTINUE
CALL PAGE

```

C  
C

```

REWIND 18
GO TO 110
200 CALL CLEAR(0)
WRITE(9,205)
205 FORMAT("SERIAL NUMBER AND ATTENUATION REQUESTED"
1" NOT FOUND ON TAPE")
220 REWIND 18
CALL PAUSE
GO TO 110

END

```

PROGRAM RDXMT

```

C
C   DIMENSION NSER(10),NDATE(10),LTL1(20),TEMP(20),GNG(288),
1GANG(32,9),GMAG(32,9),AVSWR(32,9),GAG(288),
2VMG1(288),VMAG(32,9),AMAXV(9),F(9),ISER(10),
3AMENV(9),AMAXP(9),RMSPH(9),PWRMX(9),PWRMI(9),BANG(9)
C
C   EQUIVALENCE (GANG(1,1),GNG(1)),(GMAG(1,1),GAG(1)),
1(VMAG(1,1),VMG1(1))
C
C*****
C
C   THIS PROGRAM SEARCHES MAG. TAPE FOR DATA WITH MATCHING
C   SERIAL NUMBER AND DRIVE POWER.
C
C   TRANSMIT DATA ONLY
C
C   OUTPUTS DATA TO VERSATEC IN BOTH SHORT AND LONG
C   FORMAT AS PER NADC2.
C
C   REV. C   MAY 20,1977
C   L. LAVEDAN
C*****
C
C
C   RH01=0.11512925
C   RH02=0.23025851
C   F(1) = 1235.
C   F(2)=1260.
C   F(3)=1280.
C   F(4)=1295.
C   F(5)=1300.
C   F(6)=1305.
C   F(7)=1320.
C   F(8)=1340.
C   F(9)=1365.
C
C   CALL CLEAR(0)
C   WRITE(9,100)
100 FORMAT("PROGRAM FOR LOCATING AND PROCESSING TRANSMITTER"/
16X," DATA STORED ON MAG. TAPE"//
2"PLEASE SELECT TAPE AND PUT SYSTEM ON LINE")
C
C   CALL PAUSE
C   REWIND 18
110 CALL CLEAR(0)
C   WRITE(9,120)
120 FORMAT("INPUT SERIAL NUMBER<")
C   READ(8,130)(ISER(I),I=1,10)
130 FORMAT(10I2,F4.1)
C   WRITE (9,131)
131 FORMAT ("INPUT DRIVE LEVEL (23.8,24.8,25.8)<")
C   READ (8,*) PWRB
135 READ(18,140)
140 FORMAT(I1)
C   IF(IEOF(18)) 150,160
160 GO TO 135

```

```

150 READ(18,170)LET1,(NSER(I),I=1,10),PWRA,(NDATE(I),
1I=1,10),VOLT1,VOLT2,TEMP1,TEMP2,(LTL1(I),I=1,20)
170 FORMAT(A1,10A2,F4.1,10A2,2F7.3,2F7.2,20A2)
IF(IEOF(18))200,210
210 DO 500 I=1,10
IF(ISER(I)-NSER(I)) 135,500,135
500 CONTINUE
IF(PWRA-PWRB) 135,1000,135
C
C CORRECT SER NO CONTINUES
C
1000 READ(18,1001)(VMG1(I),I=1,288)
READ(18,1001)(GAG(I),I=1,288)
READ(18,1001)(GNG(I),I=1,288)
1001 FORMAT (28(10E12.7/)10E12.7)
C
IFLG = 0
C
C ORDER PHASE STARTING WITH GANG(1,1)
C PORD ORDERS POSITIVE PHASE DELAY
CALL PORD(GANG(1,1))
DO 1240 J=2,9
1225 IF(GANG(1,J-1)-GANG(1,J)-90.0) 1235,1230
1230 GANG(1,J)=GANG(1,J)+360.0
GO TO 1225
1235 CALL PORD(GANG(1,J))
1240 CONTINUE
C
C
SUMG=0.0
SUMG2=0.0
C
FREQ LOOP
DO 1600 II=1,9
C
C INITIALIZE VALUES TO PHASE STATE
GMAX=GMAG(1,II)
IF (GMAG(1,II))1298,1259,1298
1299 IFLG=1
1298 GMIN=GMAX
VMAX=VMAG(1,II)
VAVG=VMAX
PH0=GANG(1,II)
PHMAX=0.0
SUMP2=PHMAX
SUMG=SUMG+GMAG(1,II)
SUMG2=SUMG2+GMAG(1,II)*GMAG(1,II)
C
C PHASE LOOP
DO 1335 IP=2,32
IF(GMAG(IP,II))1301,1302,1301
1302 IFLG=1
1301 IF(VMAG(IP,II)-VMAX) 1305,1305,1300
1300 VMAX=VMAG(IP,II)
1305 VAVG=VAVG+VMAG(IP,II)
IF(GMAG(IP,II)-GMAX) 1315,1315,1310
1310 GMAX=GMAG(IP,II)
1315 IF(GMIN-GMAG(IP,II)) 1325,1325,1320
1320 GMIN=GMAG(IP,II)

```



```

1325  SUMG=SUMG+GMAG(IP,II)
      SUMG2=SUMG2+(GMAG(IP,II))*(GMAG(IP,II))
      DELP=GANP(IP,II)-PH0
      DDELP=DELP-(11.25*FLOAT(IP-1))
      IF (ABS(DDELP)-ABS(PHMAX)) 1335,1335,1330
1330  PHMAX=DDELP
      SUMP2=SUMP2+DDELP*DDELP
1335  CONTINUE
C
C
C      ON A PER FREQ BASIS
C      CONVERT MAX RHO TO VSWR MAX
      AMAXV(II)=(1.0+VMAX)/(1.0-VMAX)
C      CONVERT AVG RHO TO MEAN VSWR
      AMENV(II)=(1.0+(VAVG/32.0))/(1.0-(VAVG/32.0))
C      CONVERT MAX PHASE
      AMAXP(II)=PHMAX
C      CONVERT RMS PHASE
      RMSPH(II)=SQRT(SUMP2/32.0)
      PWRMX(II)=GMAX
      PWRMI(II)=GMIN
1600  CONTINUE
C
C      MEAN POWER
      PWRME=SUMG/288.0
C      RMS POWER
      RMSPW=SQRT((SUMG2/288.0)-(PWRME*PWRME))
C
C      PRINT SEQUENCE---SHORT FORM
C
      CALL CLEAR(0)
      WRITE(11,2999)
2999  FORMAT(10(/))
C
3000  WRITE(11,3005)(NSER(I),I=1,10)
3005  FORMAT("SER.NO. ",10A2,5X,"TRANSMITTER")
      WRITE(11,3010)(NDATE(I),I=1,10)
3010  FORMAT("DATE: ",10A2)
      WRITE(11,3015)VOLT1,VOLT2
3015  FORMAT("VOLT1=",F7.3,20X,"VOLT2=",F7.3)
      WRITE(11,3020)TEMP1,TEMP2
3020  FORMAT("TEMP1=",F7.1,"DEG.C",16X,"TEMP2=",F7.1,"DEG.C")
      WRITE(11,3025)(LTL1(I),I=1,20)
3025  FORMAT(20A2/)
      WRITE(11,3030)PWRA
3030  FORMAT("INPUT POWER=",F4.1,"DBM.")
      IF(IFLG) 3031,3034,3031
3031  WRITE(11,3032)
3032  FORMAT("CAUTION--ERRORS ENCOUNTERED IN DATA")
3034  WRITE(11,3033)
3033  FORMAT(" ")
      WRITE(11,3035)(F(I),I=1,9)
3035  FORMAT("FREQ.",3X,9(2X,F4.0))
      WRITE(11,3040)(AMAXV(I),I=1,9)
3040  FORMAT("VSWR MAX ",9(X,F5.2))
      WRITE(11,3045)(AMENV(I),I=1,9)
3045  FORMAT("VSWR MEAN",9(X,F5.2))
      WRITE(11,3050)(AMAXP(I),I=1,9)

```

```

3050 FORMAT("MAX-PH-ER",9(X,F5.1))
      WRITE(11,3055)(RMSPH(I),I=1,9)
3055 FORMAT("RMS-PH-ER",9(X,F5.1))
      WRITE(11,3060)(PWRMX(I),I=1,9)
3060 FORMAT("MAX-PWR-W",9(X,F5.1))
      WRITE(11,3065)(PWRMI(I),I=1,9)
3065 FORMAT("MIN-PWR-W",9(X,F5.1))
      WRITE(11,3070)(GANG(1,I),I=1,9)
3070 FORMAT("INS PHAS ",9(X,F5.0))
      WRITE(11,3075)PWRME
3075 FORMAT("OVERALL MEAN PEAK POWER=",F5.1,"WATTS")
      WRITE(11,3080)RMSPW
3080 FORMAT("STD. DEVIATION IN OVERALL PEAK POWER=",F5.1,
1"WATTS")

```

C

CALL PAGE

C

```

4005 WRITE(11,3005)(NSER(I),I=1,10)
      WRITE(11,3010)(NDATE(I),I=1,10)
      WRITE(11,3015)VOLT1,VOLT2
      WRITE(11,3020)TEMP1,TEMP2
      WRITE(11,3025)(LTL1(I),I=1,20)
      WRITE(11,3030)PWRA
      WRITE(11,3035)(F(I),I=1,9)
      DO 4100 I=1,32
      DO 4101 J=1,9
      VMAG(I,J)=(1.0+VMAG(I,J))/(1.0-VMAG(I,J))
4101 CONTINUE
      BIT=11.25*FLOAT(I-1)
      WRITE(11,4102) BIT
4102 FORMAT(" ",F6.2," DEG.")
      WRITE(11,4105)(VMAG(I,J),J=1,9)
4105 FORMAT("VSWR",5X,9(X,F5.2))
      WRITE(11,4110)(GMAG(I,J),J=1,9)
4110 FORMAT("MAX-PWR-W",9(X,F5.1))
      IF(I-1) 4115,4115,4120
4115 WRITE(11,4125)(GANG(1,J),J=1,9)
4125 FORMAT("IPHS",5X,9(X,F5.0))
      GO TO 4100
4120 DO 4126 L=1,9
      BANG(L)=GANG(I,L)-GANG(1,L)
4126 CONTINUE
      WRITE(11,4130)(BANG(J),J=1,9)
4130 FORMAT("DEL PHASE",9(X,F5.1))
C
4100 CONTINUE
      CALL PAGE
      REWIND 18
      GO TO 110
200 CALL CLEAR(0)
      WRITE(9,205)
205 FORMAT("SERIAL NUMBER AND DRIVE POWER REQUESTED"
1" NOT FOUND ON TAPE")
220 REWIND 18
      CALL PAUSE
      GO TO 110
      END

```

## APPENDIX II

### Data acquisition programs:

NADC 1 and 2 are the two primary programs employed in hardware control and data acquisition, processing, and storage for the transceiver modules described in this report.

CALS1 is a transmitter test subroutine used in the hardware calibration sequence.

BORIS is a receiver test subroutine for calibration of the Hewlett Packard network analyzer and is similar to that used by Hewlett Packard except that it is tailored specifically to module test.



```

PROGRAM NADC1
DIMENSION NDATE(10),NSER(10),LTL1(20),CM(64,9),GMAG(32,9),
1GMAG(32,9),VMAG(32,9),AMAXV(9),AMENV(9),AMAXP(9),RMSPH(9),
2DBGMX(9),DBGMI(9),BANG(9),F(9),VANG(32,9),VMG1(288),
3VAG(288),GAG(288),GNG(288),TEMP8(9),TEMP9(9)
C
COMMON LT1ST,LT2ND,LTSTP,LINFR,LINND,EXT(3),IS(2),
1IDMY,LCAL,ICTYP,INEW,FCO,CAL(6,9)
C
EQUIVALENCE (VMAG(1,1),VMG1(1)),(VANG(1,1),VAG(1)),
1(GMAG(1,1),GAG(1)),(GANG(1,1),GNG(1))
C
C*****
C
C THIS IS A SPECISL MEASUREMENT PROGRAM FOR
C MEASURING THE REFLECTION AND TRANSMISSION BEFORE OUTPUTING
C DATA TO MAGNETIE TAPE.
C
C
C
C BORIS SHELEG 10 MARCH77
C REV M 18 MAY 77
C
C THIS IS MODIFIED GPM1
C
C*****
C
C INITIALIZE FLAGS--FIRST TIME ONLY--AND CONSTANTS
C
CALL CLRIO
C
TRAP 1 IS RETURN TO MEASURE
CALL TRAP(1)
GO TO 1000
C
TRAP 2 IS RETURN TO CALIBRATE
CALL TRAP(2)
GO TO 50
50 CALL CLEAR(0)
C
WRITE(9,80)
80 FORMAT("PUT DATA TAPE ON DECK AND ON LINE")
CALL PAUSE
WRITE(9,85)
85 FORMAT("NEW TAPE (Y OR N)=<")
CALL NYES(IV)
IF(IV) 99,90
90 ENDFILE 18
ENDFILE 18
REWIND 18
99 CONTINUE
WRITE(9,100)
100 FORMAT("DATE:",20X,"↑,10↑Y"<")
READ(8,105)(NDATE(I),I=1,10)
105 FORMAT(10A2)
C
C ENTER FREQUENCIES IN MHZ HERE
C
F(1)=1235

```

```

F(2)=1260
F(3)=1280
F(4)=1295
F(5)=1300
F(6)=1305
F(7)=1320
F(8)=1340
F(9)=1365

```

```

C
C

```

```

C CALL BORIS(F(1))
C
1000 CALL CLEAR(0)
      WRITE(9,1005)
1005 FORMAT("SER.NO.=" ,20X,"†,10††"←")
      READ(8,1007)(NSER(I),I=1,10)
1007 FORMAT(10A2)
      WRITE(9,1010)
1010 FORMAT("REMARKS:" ,40X,"†,20††"←")
      READ(8,1012)(LTL1(I),I=1,20)
1012 FORMAT(20A2)
      WRITE(9,1015)
1015 FORMAT("CONNECT DEVICE-----")
      CALL BELL
      CALL PAUSE

```

```

C
C

```

```

C MEASUREMENT CYCLE--DATA RETURNED IN CM APRAY
C

```

```

C DO 4000 ITTN=1,8
C

```

```

C CHAN 1=TEMP DEG C
C CHAN 2=TEMP DEG C
C CHAN 4=40 VOLT
C CHAN 5=12 VOLT
C

```

```

C CALL TVOLD(1,TEMP1)
C CALL TVOLD(2,TEMP2)
C CALL TVOLD(4,VOLT1)
C CALL TVOLD(5,VOLT2)
C

```

```

C SET ATTENUATION
C ITTN2=ITTN-1
C

```

```

C CALL SETPH(0,ITTN2)
C

```

```

C CALL MEASURE AT 9 FREQ AND 32 PHASES
C

```

```

C CALL MCOB1(F(1),CM)
C

```

```

C OUTPUT DATA TO MAG TAPE
C

```

```

C CONVERT CM ARRAY TO MAG AND ANGLE
C

```

```

2000 DO 2020 J=1,9
      DO 2020 I=1,32
          GANG(I,J)=ANG(CM(2*I,J))
          GMAG(I,J)=CMAG(CM(2*I,J))

```

```

      VMAG(I,J)=CMAG(CM(2*I-1,J))
      VANG(I,J)=ANG(CM(2*I-1,J))
2020 CONTINUE
      ITTN3=ITTN2*2
C
C   FIND END OF TAPE
C
2021 READ(18,2022)
2022 FORMAT(I1)
      IF(IEOF(18)) 2023,2021
2023 READ(18,2022)
      IF(IEOF(18)) 2024,2021
2024 BACKSPACE 18
C
C   PUT TITLE INFO ON TAPE
C
      WRITE(18,2025) (NSER(I),I=1,10),ITTN3,(NDATE(I),
1I=1,10),VOLT1,VOLT2,TEMP1,TEMP2,(LTL1(I),I=1,20)
C
C   PUT MEASURED DATA ON TAPE
C
2025 FORMAT("R",10A2,I2,10A2,2F7.3,2F7.2,20A2)
      WRITE(18,2027) (VMG1(I),I=1,288)
      WRITE(18,2027) (VAG(I),I=1,288)
      WRITE(18,2027) (GAG(I),I=1,288)
      WRITE(18,2027) (GNG(I),I=1,288)
2027 FORMAT(28(10E12.7/)10E12.7)
C
C   ORDER PHASE STARTING WITH GANG(1,1)
C
      CALL PHORD(GANG(1,1))
      DO 2060 J=2,9
2030 IF(GANG(1,J-1)-GANG(1,J)+90.0) 2040,2040,2050
2040 GANG(1,J)=GANG(1,J)-360.0
      GO TO 2030
2050 CALL PHORD(GANG(1,J))
2060 CONTINUE
C
C   PROCESS DATA AND PRINT OUT ON VERSATEC
C   SW 1 IS QUAL LONG FORM OPTION
C
      SET SUM GAIN TO 0
      SUMG=0.0
      SET SUM(GAIN)*2 TO 0
      SUMG2=0
C
      DO 2100 II=1,9
C   INITIALIZE VALUES TO FIRST PHASE STATE
      GMAX=GMAG(1,II)
      GMIN=GMAG(1,II)
      VMAX=VMAG(1,II)
      VAVG=VMAX
      PH0=GANG(1,II)
      PHMAX=0.0
      SUMP2=PHMAX
      SUMG=SUMG+GMAG(1,II)
      SUMG2=SUMG2+GMAG(1,II)*GMAG(1,II)
C

```



```

C      PHASE LOOP
      DO 2150 IP=2,32
C      DETERMINE REFLECTION COEFF MAX
      IF (VMAG(IP,II)-VMAX) 2070,2070,2065
2065  VMAX=VMAG(IP,II)
C      DETERMINE SUM REF. COEFF.
2070  VAVG=VAVG+VMAG(IP,II)
C      DETERMINE VOLTAGE GAIN MAX
      IF (GMAG(IP,II)-GMAX) 2080,2080,2075
2075  GMAX=GMAG(IP,II)
C      DETERMINE VOLTAGE GAIN MIN
2080  IF (GMIN-GMAG(IP,II)) 2090,2090,2085
2085  GMIN=GMAG(IP,II)
C      DETERMINE SUM OF VOLT GAIN
2090  SUMG=SUMG+GMAG(IP,II)
C      DETERMINE SUM(VOLT GAIN)2
      SUMG2=SUMG2+GMAG(IP,II)*GMAG(IP,II)
C      DETERMINE DELTA PHASE
      DELP=PH0-GANG(IP,II)
C      DETERMINE DELTA PHASE ERROR
      DDELP=DELP-(11.25*FLOAT(IP-1))
C      DETERMINE DEL PHAS ERR MAX
      IF (ABS(DDELP)-ABS(PHMAX)) 2150,2150,2095
2095  PHMAX=DDELP
C      DETERMINE SUM(DEL PHAS ERR)2
      SUMP2 = SUMP2 + DDELP*DDELP
C
2150  CONTINUE
C      ON A PER FREQ BASIS-----
C      CONVERT MAX RHO TO VSWR MAX
      AMAXV(II)=(1.0+VMAX)/(1.0-VMAX)
C      CONVERT AVG RHO TO MEAN VSWR
      AMENV(II)=(1.0+(VAVG/32.0))/(1.0-(VAVG/32.0))
C      CONVERT MAX PHASE
      AMAXP(II)=PHMAX
C      CONVERT RMS PHASE
      RMSPH(II)=SQRT(SUMP2/32.0)
C      CONVERT VOLT GAIN MAX TO MAX GAIN DB
      DBGMX(II)=20.*ALOG(GMAX)/ALOG(10.0)
C      CONVERT VOLT GAIN MIN TO MIN GAIN DB
      DBGMI(II)=20.*ALOG(GMIN)/ALOG(10.0)
C
2100  CONTINUE
C      CONVERT TO MEAN GAIN
      DBGME=20.*ALOG(SUMG/288.0)/ALOG(10.0)
C      CONVERT TO RMS GAIN
      RMSG=20.*ALOG(SQRT((SUMG2-(SUMG*SUMG/288.0))/288.0))/
1ALOG(10.0)
C
C      PRINT SEQUENCE--SHORT FORM
C
      CALL CLEAR(0)
      WRITE(11,2999)
2999  FORMAT(10(//))
C
3000  WRITE(11,3005)(NSER(I),I=1,10)
3005  FORMAT("SER.NO. ",10A2,5X,"RECEIVER")
      WRITE(11,3010)(NDATE(I),I=1,10)

```

```

3010 FORMAT("DATE: ",10A2)
      WRITE(11,3015)VOLT1,VOLT2
3015 FORMAT("VOLT1=",F7.3,20X,"VOLT2=",F7.3)
      WRITE(11,3020)TEMP1,TEMP2
3020 FORMAT("TEMP1=",F7.1,"DEG.C",16X,"TEMP2=",F7.1,"DEG.C")
      WRITE(11,3025)(LTL1(I),I=1,20)
3025 FORMAT(20A2/)
C
      ITTN1=(ITTN-1)*2
      WRITE(11,3030)ITTN1
3030 FORMAT("ATTNUATION=",I2,"DB."/)
      WRITE(11,3035)(F(I),I=1,9)
3035 FORMAT("FREQ.",3X,9(2X,F4.0))
      WRITE(11,3040)(AMAXV(I),I=1,9)
3040 FORMAT("VSWR MAX ",9(X,F5.2))
      WRITE(11,3045)(AMENV(I),I=1,9)
3045 FORMAT("VSWR MEAN",9(X,F5.2))
      WRITE(11,3050)(AMAXP(I),I=1,9)
3050 FORMAJ("MAX-PH-ER",9(X,F5.1))
      WRITE(11,3055)(RMSPH(I),I=1,9)
3055 FORMAT("RMS-PH-ER",9(X,F5.1))
      WRITE(11,3060)(DBGMX(I),I=1,9)
3060 FORMAT("MAX-GN-DB",9(X,F5.1))
      WRITE(11,3065)(DBGMI(I),I=1,9)
3065 FORMAT("MIN-GN-DB",9(X,F5.1))
      WRITE(11,3070)(GANG(1,I),I=1,9)
3070 FORMAT("INS PHAS ",9(X,F5.0))
      WRITE(11,3075)DBGME
3075 FORMAT("OVERALL MEAN GAIN=",F5.1,"DB.")
      WRITE(11,3080)RMSG
3080 FORMAT("STD. DEVIATION IN OVERALL GAIN=",F6.1,"DB.")
C
C
C      PUT PROCESSED DATA ON TAPE WITH ENDFILES
C
C      CALL PAGE
      WRITE(18,3090)(AMAXV(I),I=1,9)
      WRITE(18,3090)(AMENV(I),I=1,9)
      WRITE(18,3090)(AMAXP(I),I=1,9)
      WRITE(18,3090)(RMSPH(I),I=1,9)
      WRITE(18,3090)(DBGMX(I),I=1,9)
      WRITE(18,3090)(DBGMI(I),I=1,9)
      WRITE(18,3090)(GANG(1,I),I=1,9)
      WRITE(18,3090)DBGME,RMSG
3090 FORMAT(9E13.7)
      ENDFILE 18
      ENDFILE 18
      BACKSPACE 18
      BACKSPACE 18
C
C
C
C      SW 1 UP=LONG FORM FOR QUAL
      IF(ISP(1)) 4005,4006
4005 WRITE(11,3005)(NSER(I),I=1,10)
      WRITE(11,3010)(NDATE(I),I=1,10)
      WRITE(11,3015)VOLT1,VOLT2
      WRITE(11,3020)TEMP1,TEMP2

```

```
WRITE(11,3025)(LTL1(I),I=1,20)
WRITE(11,3030)ITTN1
WRITE(11,3035)(F(I),I=1,9)
C
C
DO 4100 I=1,32
DO 4101 J=1,9
TEMP9(J)=VSWRC(CM(2*I-1,J))
TEMP8(J)=DBC(CM(2*I,J))
4101 CONTINUE
BIT=11.25*FLOAT(I-1)
WRITE(11,4102) BIT
4102 FORMAT(" ",F6.2," DEG.")
WRITE(11,4105)(TEMP9(J),J=1,9)
4105 FORMAT("VSWR",5X,9(X,F5.2))
WRITE(11,4110)(TEMP8(J),J=1,9)
4110 FORMAT("GAIN-DB",2X,9(X,F5.1))
IF(I-1) 4115,4115,4120
4115 WRITE(11,4125)(GANG(1,J),J=1,9)
4125 FORMAT("IPHS",5X,9(X,F5.0))
GO TO 4100
4120 DO 4126 L=1,9
BANG(L)=GANG(1,L)-GANG(I,L)
4126 CONTINUE
WRITE(11,4130)(BANG(J),J=1,9)
4130 FORMAT("DEL PHASE",9(X,F5.1))
C
4100 CONTINUE
CALL PAGE
4000 CONTINUE
GO TO 1000
END
```



PROGRAM NADC2

C DIMENSION NSER(10),NDATE(10),LTL1(20),TEMP(20),GNG(288),  
 1GANG(32,9),GMAG(32,9),AVSWR(32,9),GAG(288),  
 2VMG1(288),VMAG(32,9),AMAXV(9),  
 3AMENV(9),AMAXP(9),RMSPH(9),PWRMX(9),PWRMI(9),BANG(9)

C COMMON F(9),PIMC(9),POMC(9),PVSWR(9),S2PMC(9),SAFMC(9)

C EQUIVALENCE (GANG(1,1),GNG(1)),(GMAG(1,1),GAG(1)),  
 1(VMAG(1,1),VMG1(1))

C \*\*\*\*\*

C THIS PROGRAM CALIBRATES THE S.A. EQUIPMENT AND PERFORMS  
 C THE NADC MEASUREMENT SEQUENCE.

C INPUT COUPLER AND/OR PAD INFO IS NECESSARY.

C INPUT, REFLECTED AND TRANSMITTED POWERS ARE MEASURED  
 C USING SHORT WINDOW PEAK POWER METERS. THE WINDOWS CAN  
 C BE MANUALLY MOVED THRU THE PULSE. AUTOMATIC INPUT

C POWER LEVELING IS USED WHICH IS PROGRAMABLE.

C A MAX OF 30 SAMPLES IS TAKEN AT EACH TEST CONDITION  
 C AND IF 5 ARE NOT FOUND ACCEPTABLE FOR AVERAGING,

C THEN PROGRAM GIVES ZEROS AND PROCEEDS. EQUIPMENT PULSES

C IN STANDBY UNTIL OPERATOR GIVES OK FOR TEMPERATURE

C STABILITY. PULSES ARE REMOVED BY HARDWARE WHEN

C FREQ/VOLT/PHASE/POWER IN CHANGES ARE IN PROGRESS.

C HARD COPY AND MAG TAPE OUTPUT.

C SW 1 UP FOR QUAL. LONG FORM OUTPUT.

C REV. H 5/17/77

C L.LAVEDAN 4/20/77

C \*\*\*\*\*

C SET S.A. INTERFACE

C CALL SETIP

C SET UP PULSE GENERATOR

C CALL SPULG(1,30,10,5,64)

C SET TO NOMINAL INPUT POWER

C CALL INITP(-6.0)

C RHO1=0.11512925

C RHO2=0.23025831

C DEFINE FREQUENCY SEQUENCE

C F(1)=1235

C F(2)=1260

C F(3)=1280

C F(4)=1295

C F(5)=1300

C F(6)=1305

C F(7)=1320

C F(8)=1340

C F(9)=1365

C SET FREQUENCY TO MIN BAND

```

      CALL SETFR(F(5))
C     TURN OFF OUTPUT POWER
      CALL OPULG
C
C     TRAP 1 IS RETURN TO MEASURE
      CALL TRAP(1)
      GO TO 1000
C
C     TRAP 2 IS RETURN TO CALIBRATION
      CALL TRAP(2)
      GO TO 50
C
10  CALL CLEAR(0)
      WRITE(9,12)
12  FORMAT(21X,"***S.A. TEST PROGRAM***"/"READ COUPLER"
1   " INFO FROM TAPE?+")
      CALL NYES(ITC)
      IF(ITC) 14,16
C
C     GET COUPLING INFO FROM KEYBOARD
C
14  WRITE(9,18)
18  FORMAT("TYPE IN THE FOLLOWING COUPLINGS"/"FREQ. INPUT"
1   " COUP.(+DB) OUTPUT COUP.(+DB)")
      DO 20 I=1,9
      WRITE(9,22)F(I)
22  FORMAT(F8.1,":+")
      READ(8,*)PIMC(I),POMC(I)
20  CONTINUE
      GO TO 50
C
16  WRITE(9,24)
24  FORMAT("POSITION TAPE IN DECK #2")
      CALL PAUSE
      READ(14,*)(PIMC(J),POMC(J),J=1,9)
      WRITE(9,28)(F(I),PIMC(I),POMC(I),I=1,9)
28  FORMAT(9(3F10.2/))
C
50  CALL CLEAR(0)
C
C     MAKE SURE POWER LOOP IS STILL ON
C
      CALL PLRST
      WRITE(9,80)
80  FORMAT("PUT MAG TAPE FOR DATA IN DECK AND ON LINE")
      CALL PAUSE
      WRITE(9,85)
85  FORMAT("NEW TAPE (Y OR N)=+")
      CALL NYES(IV)
      IF(IV) 99,90
90  ENDFILE 18
      ENDFILE 18
      REWIND 18
99  CONTINUE
C
      WRITE(9,25)
25  FORMAT("DATE:",20X,"^,10(1)"+"")
      READ(8,30)NDATE

```

```

30 FORMAT(20A2)
C
  PMIN=23.8
  PNOM=24.8
  PMAX=25.8
C
C CALIBRATION SEQUENCE
C
  100 CALL CLEAR(0)
  CALL CALS1
  1000 CALL OPULG
  CALL PLRST
C
  WRITE(9,1005)
  1005 FORMAT("SER.NO.="20X,"†,10††"←")
  READ(8,30)(NSER(I),I=1,10)
  WRITE(9,1010)
  1010 FORMAT("REMARKS:"40X,"†,20††"←")
  READ(8,30)(LTL1(I),I=1,20)
  WRITE(9,1015)
  1015 FORMAT("CONNECT DEVICE AND THERMOCOUPLE(1) TO DEVICE"/
1"AND PUT SWITCH 2 DOWN")
  CALL BELL
  CALL PAUSE
C
  SET PHASE AND AMPLITUDE
  CALL SETPH(0,0)
C
  RESTORE PULSE GENERATOR
  CALL RPULG
C
  TURN ON AT F(5) AND PNOM
  POWER=PNOM-PIMC(5)
  CALL SETPW(POWER)
  CALL SETFR(F(5))
C
  CALL CLEAR(0)
C
  WRITE(9,1020)
  1020 FORMAT("PUT UP SWITCH 2 FOR EXIT FROM TEMP. LOOP")
C
  TEMPERATURE LLOF---CHAN 1 ON DEVICE
  DO 1035 I=1,20
  CALL TVOLD(1,TEMP(I))
  WRITE(9,1025)TEMP(I)
  1025 FORMAT(F7.2)
  IF(ISP(2)) 1060,1030
  1030 CALL DELAY(5000)
  1035 CONTINUE
  1037 DO 1040 I=1,19
  TEMP(I)=TEMP(I+1)
  1040 CONTINUE
  CALL TVOLD(1,TEMP(20))
  CALL CLEAR(0)
  WRITE(9,1020)
  WRITE(9,1045)(TEMP(I),I=1,20)
  1045 FORMAT(20(F7.2/))
  IF(ISP(2)) 1060,1050
  1050 CALL DELAY(5000)
  GO TO 1037
C
  START MEASUREMENTS
C
  POWER INPUT LOOP

```



```

C
C
1060 DO 4000 IPL=1,3
      IFLG = 0
      DELPW=2-IPL
      PWRA=26.8-FLOAT(IPL)
      CALL CLEAR(0)
      WRITE(9,1065)PWRA
1065 FORMAT("MEASUREING FOR POWER LEVEL OF",F5.1,"DBM.")
C
C
C      CHAN1=TEMP DEG.C OF MODULE
C      CHAN2=TEMP DEG.C
C      CHAN4=40 VOLT
C      CHAN5=12 VOLT
C
      CALL TVOLD(1,TEMP1)
      CALL TVOLD(2,TEMP2)
      CALL TVOLD(4,VOLT1)
      CALL TVOLD(5,VOLT2)
C
      BEGIN FREQUENCY LOOP
      DO 1200 IFR=1,9
      POWER=PWRA-PIMC(IFR)
      CALL SETPW(POWER)
      CALL SETFR(F(IFR))
C
C      INITIATE A DELAY AND THROW FIRST DATA OUT
C
      CALL SETPH (0,0)
      CALL R5DAT(A1,A2,F1,A3,A4)
C
C      BEGIN PHASE LOOP
      DO 1200 IBT=1,32
      IBT1=IBT-1
      CALL SETPH(IBT1,0)
1080 CALL R5DAT(A1,A2,F1,A3,A4)
      IF (A2) 1085,1089,1095
1085 TMP=ABS(A2-S2PMC(IFR)-DELPW)
      IF(TMP-.3) 1090,1070
1070 WRITE(9,1075)TMP
1075 FORMAT("REF.CHAN.DIFF.=" ,F8.2,"DB. --ACCEPT IT?+")
      CALL NYES(ITC)
      IF(ITC) 1080, 1090
C
1089 IFLG = 1
1090 TMP=F1-SAFMC(IFR)
1095 IF(TMP) 1100,1105
1100 TMP=TMP+360.0
      GO TO 1095
1105 IF(TMP-360.0) 1115,1110
1110 TMP=TMP-360.0
      GO TO 1105
1115 GANG(IBT,IFR)=TMP
      TEMP3=-A3+POMC(IFR)-30.0
      GMAG(IBT,IFR)=EXP(RH02*TEMP3)
      TEMP3=-A4+PVSWR(IFR)
      VMAG(IBT,IFR)=EXP(RH01*(TEMP3-PWRA))
C

```

```

1200 CONTINUE
C
    POWER=PWRA-PIMC(1)
    CALL SETPW(POWER)
    CALL SETFR(F(1))
C
C   OUTPUT DATA TO MAG TAPE
C   FIND END OF TAPE
C
2021 READ(18,2022)
2022 FORMAT(I1)
    IF(IEOF(18)) 2023,2021
2023 READ(18,2022)
    IF(IEOF(18)) 2024,2021
2024 BACKSPACE 18
C
C   PUT TITLE INFO ON TAPE
C
    WRITE(18,2025)(NSER(I),I=1,10),PWRA,(NDATE(I),
1I=1,10),VOLT1,VOLT2,TEMP1,TEMP2,(LTL1(I),I=1,20)
2025 FORMAT("T",10A2,F4.1,10A2,2F7.3,2F7.2,20A2)
C
C   PUT MEASURED DATA ON TAPE
C
    WRITE(18,2027)(VMG1(I),I=1,288)
    WRITE(18,2027)(GAG(I),I=1,288)
    WRITE(18,2027)(GNG(I),I=1,288)
2027 FORMAT(28(10E12.7/))10E12.7)
C
C
C   ORDER PHASE STARTING WITH GANG(1,1)
C   PORD ORDERS POSITIVE PHASE DELAY
C   CALL PORD(GANG(1,1))
    DO 1240 J=2,9
1225 IF(GANG(1,J-1)-GANG(1,J)-90.0) 1235,1230
1230 GANG(1,J)=GANG(1,J)+360.0
    GO TO 1225
1235 CALL PORD(GANG(1,J))
1240 CONTINUE
C
C
    SUMG=0.0
    SUMG2=0.0
C
    FREQ LOOP
    DO 1600 II=1,9
C
C   INITIALIZE VALUES TO PHASE STATE
    GMAX=GMAG(1,II)
    GMIN=GMAX
    VMAX=VMAG(1,II)
    VAVG=VMAX
    PH0=GANG(1,II)
    PHMAX=0.0
    SUMP2=PHMAX
    SUMG=SUMG+GMAG(1,II)
    SUMG2=SUMG2+GMAG(1,II)*GMAG(1,II)
C
C   PHASE LOOP

```

```

DO 1335 IP=2,32
  IF (VMAG(IP,II)-VMAX) 1305,1305,1300
1300 VMAX=VMAG(IP,II)
1305 VAVG=VAVG+VMAG(IP,II)
  IF (GMAG(IP,II)-GMAX) 1315,1315,1310
1310 GMAX=GMAG(IP,II)
1315 IF (GMIN-GMAG(IP,II)) 1325,1325,1320
1320 GMIN=GMAG(IP,II)
1325 SUMG=SUMG+GMAG(IP,II)
  SUMG2=SUMG2+(GMAG(IP,II))*(GMAG(IP,II))
  DELP=GANG(IP,II)-PH0
  DDELP=DELP-(11.25*FLOAT(IP-1))
  IF (ABS(DDELP)-ABS(PHMAX)) 1335,1335,1330
1330 PHMAX=DDELP
  SUMP2=SUMP2+DDELP*DDELP
1335 CONTINUE
C
C
C   ON A PER FREQ BASIS
C   CONVERT MAX RHO TO VSWR MAX
  AMAXV(II)=(1.0+VMAX)/(1.0-VMAX)
C   CONVERT AVG RHO TO MEAN VSWR
  AMENV(II)=(1.0+(VAVG/32.0))/(1.0-(VAVG/32.0))
C   CONVERT MAX PHASE
  AMAXP(II)=PHMAX
C   CONVERT RMS PHASE
  RMSPH(II)=SQRT(SUMP2/32.0)
  PWRMX(II)=GMAX
  PWRMI(II)=GMIN
1600 CONTINUE
C
C   MEAN POWER
  PWRME=SUMG/288.0
C   RMS POWER
  RMSPW=SQRT((SUMG2/288.0)-(PWRME*PWRME))
C
C   PRINT SEQUENCE---SHORT FORM
C
  CALL CLEAR(0)
  WRITE(11,2999)
2999 FORMAT(10(/))
C
3000 WRITE(11,3005)(NSER(I),I=1,10)
3005 FORMAT("SER.NO. ",10A2,5X,"TRANSMITTER")
  WRITE(11,3010)(NDATE(I),I=1,10)
3010 FORMAT("DATE: ",10A2)
  WRITE(11,3015)VOLT1,VOLT2
3015 FORMAT("VOLT1=",F7.3,20X,"VOLT2=",F7.3)
  WRITE(11,3020)TEMP1,TEMP2
3020 FORMAT("TEMP1=",F7.1,"DEG.C",16X,"TEMP2=",F7.1,"DEG.C")
  WRITE(11,3025)(LTL1(I),I=1,20)
3025 FORMAT(20A2/)
  WRITE(11,3030)PWRM
3030 FORMAT("INPUT POWER=",F4.1,"DBM.")
  IF(IFLG) 3031,3034,3031
3031 WRITE(11,3032)
3032 FORMAT("CAUTION--ERRORS ENCOUNTERED IN DATA")
3034 WRITE(11,3033)

```



```

3033 FORMAT (" ")
      WRITE(11,3035)(F(I),I=1,9)
3035 FORMAT("FREQ.",3X,9(2X,F4.0))
      WRITE(11,3040)(AMAXV(I),I=1,9)
3040 FORMAT("VSWR MAX ",9(X,F5.2))
      WRITE(11,3045)(AMENV(I),I=1,9)
3045 FORMAT("VSWR MEAN",9(X,F5.2))
      WRITE(11,3050)(AMAXP(I),I=1,9)
3050 FORMAT("MAX-PH-ER",9(X,F5.1))
      WRITE(11,3055)(RMSPH(I),I=1,9)
3055 FORMAT("RMS-PH-ER",9(X,F5.1))
      WRITE(11,3060)(PWRMX(I),I=1,9)
3060 FORMAT("MAX-PWR-W",9(X,F5.1))
      WRITE(11,3065)(PWRMI(I),I=1,9)
3065 FORMAT("MIN-PWR-W",9(X,F5.1))
      WRITE(11,3070)(GANG(1,I),I=1,9)
3070 FORMAT("INS PHAS ",9(X,F5.0))
      WRITE(11,3075)PWRME
3075 FORMAT("OVERALL MEAN PEAK POWER=",F5.1,"WATTS")
      WRITE(11,3080)RMSPW
3080 FORMAT("STD. DEVIATION IN OVERALL PEAK POWER=",F5.1,
1"WATTS")
C
C PUT PROCESSED DATA ON TAPE
C WITH ENDFILES
C CALL PAGE
      WRITE(18,3090)(AMAXV(I),I=1,9)
      WRITE(18,3090)(AMENV(I),I=1,9)
      WRITE(18,3090)(AMAXP(I),I=1,9)
      WRITE(18,3090)(RMSPH(I),I=1,9)
      WRITE(18,3090)(PWRMX(I),I=1,9)
      WRITE(18,3090)(PWRMI(I),I=1,9)
      WRITE(18,3090)(GANG(1,I),I=1,9)
      WRITE(18,3090)PWRME,RMSPW
3090 FORMAT(9E13.7)
      ENDFILE 18
      ENDFILE 18
      BACKSPACE 18
      BACKSPACE 18
C
C SW 1 UP= LONG FORM FOR QUAL
      IF (IFLG) 4005,4004,4005
4004 IF(ISP(1)) 4005,4000
4005 WRITE(11,3005)(NSER(I),I=1,10)
      WRITE(11,3010)(NDATE(I),I=1,10)
      WRITE(11,3015)VOLT1,VOLT2
      WRITE(11,3020)TEMP1,TEMP2
      WRITE(11,3025)(LTL1(I),I=1,20)
      WRITE(11,3030)PWRA
      WRITE(11,3035)(F(I),I=1,9)
      DO 4100 I=1,32
      DO 4101 J=1,9
      VMAG(I,J)=(1.0+VMAG(I,J))/(1.0-VMAG(I,J))
4101 CONTINUE
      BIT=11.25*FLOAT(I-1)
      WRITE(11,4102) BIT
4102 FORMAT(" ",F6.2," DEG.")
      WRITE(11,4105)(VMAG(I,J),J=1,9)

```

```
4105 FORMAT("VSWR",5X,9(X,F5.2))
      WRITE(11,4110)(GMAG(I,J),J=1,9)
4110 FORMAT("MAX-PWR-W",9(X,F5.1))
      IF(I-1) 4115,4115,4120
4115 WRITE(11,4125)(GANG(1,J),J=1,9)
4125 FORMAT("IPHS",5X,9(X,F5.0))
      GO TO 4100
4120 DO 4126 L=1,9
      BANG(L)=GANG(I,L)-GANG(1,L)
4126 CONTINUE
      WRITE(11,4130)(BANG(J),J=1,9)
4130 FORMAT("DEL PHASE",9(X,F5.1))
C
4100 CONTINUE
      CALL PAGE
4000 CONTINUE
      CALL SETFR(F(5))
      CALL SETPW(-6.0)
      CALL OPULG
C
      GO TO 1000
      END
```

```

SUBROUTINE CALS1
COMMON F(9),PIMC(9),POMC(9),PVSWR(9),S2PMC(9),
1SAFMC(9),
C*****
C
C   CALIBRATION ROUTINE FOR S.A. NADC PROGRAM
C   INCLUDING VSWR AND VERIFICATION
C
C   REV.A   APR.21,1977
C*****
C
C   INITIAL SETUP
C
10  CALL SPULG(1,30,10,5,16)
    POWER=24.8-PIMC(5)
    CALL SETPW(POWER)
    CALL SETFR(F(5))
    WRITE(9,110)
110  FORMAT("ADJUST POWER LEVEL FOR ZERO VOLTS")
    CALL BELL
    CALL PAUSE
    POWER=26.8-PIMC(5)
    CALL SETPW(POWER)
    WRITE(9,100)
100  FORMAT("MAX. GAIN OF MODULE (DB):<")
    READ(8,*)GMAX
    GMAX=-GMAX-2.0
    WRITE(9,120) GMAX
120  FORMAT("ADJUST RECEIVER GAINS AS FOLLOWS:"/
1     "REF. CHANNEL... -2.0 DB."/
2     "TEST CHANNEL "F8.1" DB"/"TO CONTINUE, LIFT SWITCH 8")
130  CALL RAPHD(A1,A2,F1,A3,A4)
    IF(ISP(8)) 140,130
140  CALL RSDAT(A1,A2,F1,A3,A4)
    WRITE(9,150)
150  FORMAT("PUT SWITCH 8 DOWN")
    CALL BELL
160  IF(ISP(8)) 160,165
165  CALL SPULG(1,30,10,5,64)
    CALL DELAY(20)
    CALL RSDAT(A11,A21,F1,A3,A4)
    TMP=-20.91515
    A1=A1+TMP
    A2=A2+TMP
    WRITE(9,170) A1,A2,A11,A21
170  FORMAT("TEST AMPLITUDE READINGS WERE:"
1     /"EXPECTED: TEST CHANNEL="F6.1" REF. CHANNEL="F6.1
2     /"MEASURED: TEST CHANNEL="F6.1" REF. CHANNEL="F6.1
3     /"OK TO CONTINUE?<")
    CALL NYES(ITC)
    IF(ITC) 10,200
200  CALL CLEAR(0)
    DO 220 I=1,5
210  CALL SETFR(F(I))
    POWER=24.8-PIMC(I)
    CALL SETPW(POWER)
    CALL DELAY(20)

```



```

      CALL R5DAT(A1,S2PMC(I),SAFMC(I),A3,A4)
220 CONTINUE
240 CALL SETFR(F(I))
      POWER=24.8-PIMC(I)
      WRITE (9,250)
250 FORMAT ("VERIFY CALIBRATION?←")
      CALL NYES(ITC)
      IF (ITC) 290,260
260 DO 280 I = 1, 9
      POWER = 24.8-PIMC(I)
      CALL SETFR(F(I))
      CALL SETPW(POWER)
      CALL DELAY(20)
      CALL R5DAT(A1,A2,F1,A3,A4)
      A2=A2-S2PMC(I)
      F1=F1-SAFMC(I)
1000 IF (F1) 1001,1005
1001 F1 = F1 + 360.0
      GO TO 1000
1005 IF (F1-360.0) 1010,1006
1006 F1 = F1 - 360.0
      GO TO 1005
1010 A3 = -A3 + POMC(I)
      WRITE (9,270) F(I),A2,F1,A3
270 FORMAT(4F10.2)
280 CONTINUE
      GO TO 240
290 CALL CLEAR(0)
      WRITE (9,300)
300 FORMAT ("CONNECT SYSTEM AS FOLLOWS:"/
1 "VSWR POWER METER TO VSWR PORT"/
2 "SHORT ON MODULE/HI-POWER PORT AT END OF CABLE")
      CALL PAUSE
      DO 350 I = 1, 9
      POWER = 24.8 - PIMC(I)
      CALL SETFR(F(I))
      CALL SETPW(POWER)
      CALL DELAY(20)
      CALL R1DAT(A4)
C SVSWR(I) IS TO BE SUBTRACTED FROM A4 DURING MEASUREMENT
      PVSUR(I) = 24.8 + A4
350 CONTINUE
      CALL CLEAR(0)
      CALL SETFR(F(5))
      CALL SETPW(-6.0)
      END

```

```

SUBROUTINE BORIS(F)
DIMENSION F(2),C(6),IC(12),CAL(6,2),TEM(2,9)
COMMON ID(11),IS(2),I1(3),INEM,FCO,ICAL(12,2)
EQUIVALENCE (C,IC),(CAL,ICAL)
C
C*****
C THIS IS A ONE PATH CALIBRATION
C 6 PARAMETER ERROR MODEL
C CALLED BY BORIS(F)
C WHERE F IS START FREQUENCY ARRAY
C INEM IS FLAG TO TRAP CALL, SET TO - AT END
C OF NORMAL CALIBRATION
C
C BORIS SHEHEG MAR. 4,1977
C REV I APR 26,1977
C
C THIS IS MODIFIED CALB1
C
C*****
C INITIALIZE AND DEFINE CONSTANTS
C
C DEFINE S11 AND S21 FOR COMMON AND MCOR1
C IS(1)=11
C IS(2)=21
C
C F1=F(1)
C CALL FCALF(F1)
C CALL BCNT1(F1)
C CALL CPAK2(1.0,0.0,C1)
C
C MEASURE LOADS
C
C
C 75 CALL SSEL1(11)
C M=1
C MN=1
C IP=1
C
C
C 110 KOP=3
C WRITE(2,905)
C 905 FORMAT("PORT 1: CONNECT FEMALE SMA LOAD")
C CALL PAUSE
C GO TO 9000
C
C
C MEASURE CROSSTALK
C
C 200 CALL FREQ2(F1)
C WRITE(2,908)
C 908 FORMAT("CONNECT FEMALE SMA LOADS, TWO PORTS FOR ISOL.")
C CALL SSEL1(21)
C CALL PAUSE
C IP=5
C KOP=4
C M=1
C GO TO 9000

```

```
C
C
C      TEST FOR DESTINATION
C
C      MEASURE SHORTS
C
305  CALL SSEL1(11)
      CALL FREQ2(F1)
      IP=2
      KOP=5
310  WRITE(2,913)
913  FORMAT("PORT 1: CONNECT SMA FEMALE SHORT")
      CALL PAUSE
      M=1
      GO TO 9000
C
C
C      MEASURE OPEN
C
C
400  M=1
      IP=3
      KOP=6
430  CALL FREQ2(F1)
C
C
480  WRITE(2,930)
930  FORMAT("PORT 1: CONNECT SMA FEMALE OPEN")
      CALL PAUSE
      GO TO 9000
C
C
550  RAD=2.0*ATAN(0.032*FL*3.14159E-4)
      T3=1.0
C
560  CALL CSUB2(C(1),C(2),T1)
      CALL CSUB2(C(3),C(1),T2)
      CALL PSFT2(0.0,T3,RAD,T2,T3)
C
580  CALL CSUB2(T3,T1,T3)
C
      CALL CADD2(T2,T1,T4)
      CALL CDIV2(T3,T4,T5)
      CALL CADD2(C1,T5,T3)
      CALL CMPY2(T3,T1,C(2))
      C(3)=T5
      GO TO 9250
C
C
C      CONNECT THRU S11 AND S21
C
1005 WRITE(2,935)
935  FORMAT("CONNECT THRU FEMALE/FEMALE SMA ADAPTER")
      CALL FREQ2(F1)
      CALL PAUSE
      M=1
C
C
```



```

C      REFLECTION
C
1010  IP=6
      KQP=7
      GO TO 9000
C
C
C      TRANSMISSION
C
1500  IP=4
      KQP=8
      M=M2
      CALL SSEL1(21)
      GO TO 9000
C
1030  RL1=1.22
      T4=RL1*4.193E-4
      CALL CSUB2(C(6),C(1),T1)
      CALL CMPY2(T1,C(3),T2)
      CALL CADD2(T2,C(2),T2)
      CALL CDIV2(T1,T2,C(6))
      CALL PSFT2(0.0,FL,T4,C(6),C(6))
      GO TO 9250
C
C
1130  T3=RL1*2.0965E-4
      CALL CSUB2(C(4),C(5),T1)
      CALL CMPY2(C(3),C(6),T2)
      CALL PSFT2(0.0,FL,T4,T2,T2)
      CALL CSUB2(C1,T2,T2)
      CALL CMPY2(T2,T1,C(4))
      CALL PSFT2(0.0,FL,T3,C(4),C(4))
      GO TO 9250
C
C
C      RETURN TO MAIN PROGRAM
C
C
2000  CALL FREQ2(F1)
      )NEW=-1
1170  CALL CLEAR(0)
1172  WRITE(9,1175)
1175  FORMAT("VERIFY CALIBRATION(Y OR N)?+")
      CALL NYES(N1)
      IF(N1) 1180,1185
1185  CALL CLEAR(0)
      WRITE(9,1190)
1190  FORMAT("CONNECT THRU---")
      CALL PAUSE
C
C
C      VERIFICATION MEASUREMENT SEQUENCE
C
      CALL BCNT1(F(1))
      CALL SSEL1(11)
      DO 1200 I=1,9
      CALL FREQ2(F(I))
      CALL MEAS1(500,V1,V2)
      CALL CPAK2(V1,V2,V1)

```

```

CALL CSUB2(V1,CAL(1,I),V1)
CALL CDIV2(V1,CAL(2,I),V2)
CALL CMPY2(V2,CAL(3,I),V1)
CALL CADD2(C1,V1,V1)
CALL CDIV2(V2,V1,TEM(1,I))
1200 CONTINUE
CALL SSEL1(21)
DO 1210 I=1,9
CALL FREQ2(F(I))
CALL MEAS1(500,V1,V2)
CALL CPAK2(V1,V2,V1)
CALL CSUB2(V1,CAL(5,I),V1)
CALL CDIV2(V1,CAL(4,I),V2)
CALL CMPY2(TEM(1,I),CAL(3,I),V1)
CALL CSUB2(C1,V1,V1)
CALL CMPY2(V1,V2,TEM(2,I))
1210 CONTINUE
C
CALL CLEAR(0)
DO 1220 I=1,9
TE1=CMAG(TEM(1,I))
TE2=ANG(TEM(1,I))
TE3=CMAG(TEM(2,I))
TE4=ANG(TEM(2,I))
WRITE(9,1222)F(I),TE1,TE2,TE3,TE4
1222 FORMAT(F4.0,4(5X,F9.3))
1220 CONTINUE
GO TO 1172
1180 CALL CLEAR(0)
CALL FREQ2(F(1))
RETURN
C
C
C
C
C
C
TEST LOOP*****
C
9000 NAVEC=-5
CRA=0.2
CALL CPAK2(CRA,0.0,CRA)
9010 FN=F(M)
IT1=-1
M2=M
CALL FREQ2(FN)
C
9100 MN=M+1
FL=FN
FN=F(MN)
C
C
9130 CALL MEAS1(100,T1,T2)
IF(9-MN) 9552,9150
9552 IT1=1
GO TO 9140
9150 CALL FREQ2(FN)
C
9140 CALL CPAK2(T1,T2,T1)
IF(NAVEC+5) 9220,9220,9200

```

```
9200 CALL CADD2(CAL(IP,M),T1,T1)
9220 CAL(IP,M)=T1
      IF(NAVEC+1) 9300,9230
9230 CALL CMPY2(CRA,T1,CAL(IP,M))
      DO 9240 N=1,12
9240      IC(N)=ICAL(N,M)
      GO TO(9300,200,9300,9300,9300,550,1030,1130)KOP
9250      DO 9260 N=1,12
9260      ICAL(N,M)=IC(N)
C
9300 IF(IT1) 9320,9310
9320 M=MN
      GO TO 9100
9310 NAVEC=NAVEC+1
      IF(NAVEC) 9330,9920
9330 M=M2
      GO TO 9010
C
C
9920 GOTO(200,200,200,305,400,1005,1500,2000)KOP
C
C
      END
```



### APPENDIX III

#### IO Drivers:

MCOR1 is a driver for calling the various microwave equipments necessary for an actual receiver measurement. It is similar to a Hewlett Packard program by the same name but has been tailored specifically for receiver module measurements. It includes a call to set the phase (and amplitude) of the receiver.

SIGDR is a four entry subroutine that controls and levels the transmitter input power on an interrupt basis.

SETPH is a subroutine used to control the phase and attenuation settings of the module for both transmit and receive.

```

NAM MCOR1
ENT MCOR1
EXT .ENTR,FREQ2,MEAS1,CPAK2,CADD2,CPY2,CDIV2
EXT CSUB2,SSEL1,BCNT1,FLOAT,NBNDP,SETPH
COM DMY1(11),IS(2),DMY2(6),CAL
*
*****
* MAKES CORRECTED MEASUREMENTS OF TRANSMISSION AND
* REFLECTION. ACCESS FREQUENCY THRU ARRAY PASSED THRU
* MAIN PROGRAM
* FORM OF CALL FROM FORTRAN IS: CALL MCOR1(F1ST,CM)
* WHERE F1ST IS THE STARTING ADDRESS OF THE FREQUENCY ARRAY
* STORED IN THE CALLING PROGRAM. AND CM IS THE CORRECTED
* DATA ARRAY.
*
* IS(1)=11 AND IS(2)=21
*
* CM ARRAY=CM(64,9)
*
* REV. D APR 25, 1977
*
* MARCH 15, 1977 B. SHELEG
*****
*
F1ST NOP
CM NOP
* DATA ARRAY ADDR
MCOR1 NOP
JSB .ENTR
DEF F1ST
*
JSB BCNT1 BEAM CENTER
DEF ++2
DEF F1ST,I
*
*
CLA INA
STA M
LDA S1DEF IP=INDERECT THRU S1
STA IP
CLA
STA ITR FULL REF. AND TRANS.
*
*
* SCAN FOR S11 (IP PRESET)
*
A1 JSB SSEL1 SELECT REFLECTION
DEF ++2
DEF IS
LDA CDI
STA ATA1
INA
STA ATA2
JSB AT1 START MEASUREMENT
*
*
* MEASURE S21

```

```

*
A2   ISZ IP           S21
     NOP
     CCA
     STA ITR          FLAG ITR=-1
     LDA CDI          SET UP TRACKING
     ADA THRE         AND LEAKAGE CAL ADDRESSES
     STA ATA2
     INA
     STA ATA1
     JSB SSEL1        S21
     DEF ++2
     DEF IS+1
     JSB AT1          START MEASUREMENT SCAN
*
*
A10  JSB FREQ2        RESET TO FIRST FREQ
     DEF ++2
     DEF F1ST,I
     JMP MCOR1,I
*
*
* CORRECTION FOR REFLECTION
CQRR JSB CMPY2
     DEF ++4
     DEF C3,I
     DEF S1,I
     DEF T1
     JSB CADD2
     DEF ++4
     DEF CONE
     DEF T1
     DEF T1
     JSB CDIV2
     DEF ++4
     DEF S1,I         S1=T11/(1+T11*E11)
     DEF T1
     DEF S1,I
*
*
* CORRECTION TO S21 FOR SOURCE MATCH ERROR
*
     JSB CMPY2        D=1-S1*E11
     DEF ++4
     DEF S1,I
     DEF C3,I
     DEF T1
     JSB CSUB2
     DEF ++4
     DEF CONE
     DEF T1
     DEF T1
     JSB CMPY2        S21=T1*T21
     DEF ++4
     DEF T1
     DEF S2,I
     DEF S2,I
     JMP AT8

```



```

*
*
* TEST LOOP
*
AT1   NOP           ENTRY POINT
      JSB  FREQ2    SET FIRST FREQUENCY
      DEF  ++2
      DEF  F1ST,I
      LDA  DLY1     SET LONG DELAY
      STA  IDLY
      CLA
      STA  P        SET FIRST PHASE
      JSB  SETPH
      DEF  ++2
      DEF  P
      CLA
      STA  IT1     NOT LAST FREQ
      CCA
      STA  IT3     NEED NEW CALIB DATA
      CLA,INA
      STA  M        SET M=FIRST FREQ
*
*
      JMP  AT3
*
AT2   LDA  M        SET UP NEXT FREQ
      INA
      STA  MN
      CMA,INA
      ADA  NINE
      STA  IT1     IF IT1<0 DOING LAST FREQ
      SSA
      JMP  AT3     LAST FREQ--DONT SET NEW
      LDA  M        M=MN-1
      ALS
      ADA  F1ST    ADDRESS OF FREQ
      STA  IFN     SAVE ADDRESS
*
*
AT3   LDA  P        SET UP NEXT PHASE
      INA
      STA  P
      CMA,INA
      ADA  D31
      STA  IT2     SET LAST PHASE FLAG
      SSA,RSS     YES--NEXT PHASE IS ZERO
      JMP  AT4
      CLA
      STA  P
*
*
AT4   JSB  MEAS1    READ VOLTAGES
      DEF  ++4
      DEF  IDLY
      DEF  T1
      DEF  T2
      JSB  SETPH    SET NEXT PHASE
      DEF  ++2

```

```

DEF P
LDA DLY3      SET SHORT DELAY
STA IDLY
LDA IT2
SSA,RSS      TEST FOR LAST PHASE
JMP AT5      NO, NO NEW FREQ
LDA IT1      WAS LAST FREQ?
SSA
JMP AT5      YES, NO NEW FREQ
JSB FREQ2    NO, SET NEW FREQ
DEF *+2
IFN NOP
LDA DLY2      SET MED DELAY
STA IDLY
LDA M1       SET NEW CALIB FLAG
STA IT3
JMP AT51     SKIP NEW CAL SECTION
*
AT5 LDA IT3
SSA,RSS      NEED NEW CALIB?
JMP AT51     NO
LDA M
MPY TWLV
ADA CALD     CALIB ADDER -12
LDB MSIX
STB CNTR
LDB CDEF
STA 1,I      STORE POINTERS
ADA TWO
INB
ISZ CNTR
JMP *-4
CCA         -1 TO A
ADA M
MPY ON28
ADA CM      GET DATA SDDRESS
STA S1
ADA TWO
STA S2
CLA         SET NEW CALIB FLAG TO NO
STA IT3
*
*
AT51 JSB CPAK2  PACK DATA
DEF *+4
DEF T1
DEF T2
DEF T1
JSB CSUB2   SUBTRACT LEAKAGE
DEF *+4
DEF T1
ATA1 NOP
DEF T1
JSB CDIV2   DIVIDE BY TRACKING
DEF *+4
DEF T1
ATA2 NOP
DEF IP,I    STORE IN .CM.

```

```

LDB ITR
SSB
JMP CORR          RETURN FOR CORRECTION
*
AT8 LDA S1
ADA FOUR          UPDATE STORAGE
STA S1
ADA TWO
STA S2
LDA IT2
SZA,RSS          LAST PHASE?
JMP AT2          YES--SET UP NEW FREQ
SSA,RSS          FREQ DONE?
JMP AT3          NO--SET UP NEXT PHASE
LDA MN           STARTING NEW FREQ
STA M
LDA IT1
SSA,RSS          ALL DONE?
JMP AT3          NO NEXT PHASE
CLA,INA
STA M
JMP AT1,I        SET UP M AGAIN

```

```

*
* VARIABLES
*

```

```

M      NOP
IP     NOP
T1     BSS 2
T2     BSS 2
MN     NOP
ITR    NOP
* T11,T22 USE C1,C2,C4,C5
CNTR   NOP
IDLY   NOP
IT1    NOP
IT2    NOP
IT8    NOP
P      NOP
C1     NOP
C2     NOP
C3     NOP
C4     NOP
C5     .NOP
C6     NOP
S1     .NOP
S2     NOP
*

```

```

* CONSTANTS

```

```

M1     DEC -1
TWO    DEC 2
THRE   DEC 3
FOUR   DEC 4
S1DEF  DEF S1,I
CONE   OCT 40000    COMPLEX ONE
        OCT 2
DLY1   DEC 500

```



DLY2 DEC 100  
DLY3 DEC 1  
D31 DEC 31  
QN28 DEC 128  
TWLV DEC 12  
CALD DEF CAL-14B  
MSIX DEC -6  
CDEF DEF C1  
CDI DEF C1,I  
B1 DEC -36  
NINE DEC 9  
\*  
\*  
END

```

NAM SETPH
ENT SETPH
EXT .ENTR

```

```

*
*
*****
* 8500 BCS COMPATABLE PHASE AND AMPLITUDE
* CONTROL ROUTING
*
* MARCH 21, 1977
* M. B. LAING
* REV. A MAY 11, 1977
*
* CALLING SEQUENCE
* CALL SETPH(IPHASE, IATTN)
* WHERE
* IPHASE IS A PHASE CODE FROM 0 TO 31
* OR -1 IF PREVIOUS VALUE IS TO BE USED
* IATTN IS AN ATTENUATOR CONTROL CODE
* FROM 0 TO 7 OR -1 IF PREVIOUS VALUE
* IS TO BE USED
*
*
*****

```

```

*
* SET CONTROL CARD ADDRESSES
*
IPD EQU 51B
DEF IPHS
DEF I01
DEF I02
DEF I03

*
IPHAS NOP PHASE WORD ADDRESS
IAMP NOP AMP. WORD ADDRESS
SETPH NOP ENTRY
      JSB .ENTR
      DEF IPHS
      LDA IPHS, I GET PHASE CODE
      SSA TEST NEW VALUE
      LDA PHAS NO, USE OLD
      AND MM37 MASK
      STA PHAS SAVE
      ALS, ALS SHIFT
      ALS
      STA TMP
      LDA IAMP, I GET AMP CODE
      SSA NEW VALUE?
      LDA AMP NO, LOAD OLD
      AND MM3 MASK
      STA AMP SAVE
      IOR TMP COMBINE AMP AND PHASE
101 OTA IPD OUTPUT
102 STC IPD, C STROBE
103 CLC IPD, C TURN OFF STROBE
      JMP SETPH, I EXIT
*
*

```

MM37 OCT 037  
MM3 OCT 03  
AMP BSS 1  
PHAS BSS 1  
TMP BSS 1

\*  
\*

END



```

HED POWER LEVELING LOOP ROUTINES
NAM SIGDR
ENT INITP,SETPW,PLOFF,PLRST
EXT .ENTR,.DLD,.FMP,IFIX
EXT .DIV,.MPY,SRFLR
SPC 1

```

```
*****
```

```

*
* SIGNAL GENERATOR DRIVER FOR USE WITH
* S.A. TEST RACK.
*

```

```

* CALLING SEQUENCES
* CALL INITP (POWER)
* CALL SETPW (POWER)
* CALL PLOFF (VOLTS)
* CALL PLRST
*

```

```

* WHERE POWER IS THE DESIRED LOOP LEVEL
* IN DBM, AND VOLTAGE IS DESIRED VOLTAGE
* SETTING OF THE DVS. POWER MUST BE IN
* THE RANGE +5.0 DBM TO +23.0 DBM, AND
* VOLTS MUST LIE BETWEEN -16.0 AND +16.0.
* INITP INITIALIZES THE POWER LEVELING LOOP
* AND SETPW ALLOWS THE CHANGING OF THE LOOP
* LEVEL. PLOFF DISABLES THE LOOP AND SETS
* THE DVS TO THE DESIRED VOLTAGE. PLRST
* REARMS THE LOOP, USING THE PREVIOUS
* POWER LEVEL AND VOLTAGE. ALL ENTRIES
* SET BOTH PERF (POWER ERROR FLAG) AND
* OFRF (OUT OF RANGE FLAG) TO 1.
*

```

```

* M.B.LAING MODIFIED 3/29/77
*

```

```
*****
```

```

* SPC 1
* DEFINE POWER METER, DVS, AND STATUS PANEL SELECT SLOTS
SPC 1
PMS EQU 14B
DVS EQU 17B
FLAGR EQU 50B
SPC 1
DEF IPWR
DEF I01
DEF I02
DEF I03
DEF I04
DEF I05
DEF I06
DEF I07
DEF I08
DEF I09
DEF I09A
DEF I010
DEF I011
DEF I012
DEF I013

```

```

DEF I014
DEF I015
DEF I016
SKP
IPWR BSS 1
INITP NOP ENTRY POINT FOR INITIALIZATION
JSB .ENTR
DEF IPWR
I01 CLC PMS,C DISABLE INTERRUPT
JSB GPTL GET POWER LEVEL
STA IDBMD SET LEVEL
STA LPR
JSB .MPY GET VOLTAGE
DEF VCF
JSB TVOLT LIMIT TO +-5.0
STA VOFST SAVE
JSB VOUT SET VOLTAGE
CLA
STA VC
LDA IJSB
I02 STA PMS SET TRAP
JSB SFB SET ERROR FLAGS
STC 0 ARM INTERRUPT SYSTEM
I03 STC PMS,C ARM POWER METER
JMP INITP,I EXIT
IJSB JSB LINK,I
ORB
LINK DEF CONT SET UP LINK
ORR
IPWR1 BSS 1
SETPW NOP ENTRY POINT
JSB .ENTR
DEF IPWR1
LDA IPWR1
STA IPWR
JSB GPTL GET POWER
STA IDBMD SET LEVEL
JSB SFB SET ERROR FLAGS
JMP SETPW,I EXIT
SKP
IVLT BSS 1
PLOFF NOP ENTRY LOOP OFF
JSB .ENTR
DEF IVLT
I04 CLC PMS,C DISARM LOOP
CLA
I05 STA PMS CLEAR TRAP
JSB .DLD GET VOLTAGE
DEF IVLT,I
JSB .FMP
DEF D2000 SCALE TO INTEGER
JSB IFIX
STA 1
AD2 HV LIM LIMIT TO 16 VOLT RANGE
SSB
LDA LVLIM
LDB 0
AD2 LVLIM

```

	SSB,RSS	
	LDA HVLIM	
	JSB VOUT	OUTPUT VOLTAGE
	JSB SFB	SET ERROR FLAGS
	JMP PLOFF,I	
PLRST	NOP	ENTRY TO RESET LOOP
	ISZ PLRST	
	LDA VOFST	GET LAST VOLTAGE
	JSB VOUT	OUTPUT VOLTAGE
	JSB SFB	SET ERROR FLAGS
	LDA IJSB	SET TRAP
I06	STA PMS	
	STC 0	ARM INTERUPT
I07	STC PMS,C	ARM POWER METER
	JMP PLRST,I	EXIT
	SKP	
CONT	NOP	ENTRY POINT FOR LOOP
I08	CLC PMS,C	DISARM INTERUPT
	STA AR	SAVE REGISTERS
	STB BR	
	ERA,ALS	
	OCT 102201	OCT FOR SOC
	INA	
	STA ER	
I09	LIA PMS	READ POWER METER
	CMA	
	LDB D13	SET FOR 13 BITS
	JSB BCDTB	CONVERT TO BINARY
	CMA,INA	GET CORRECT SIGN
	STA POWER	SAVE
	CPA IDBMD	COMPARE TO LEVEL
	JMP EXACT	GOOD LEVEL
	STA 1	
I09A	LIA FLAGR	
	AND B4	
	SZA	
	JMP *+8	
	LDA 1	
	ADA D200	TEST FOR OUT OF RANGE
	SSA	
	JMP OFR	
	ADB M100	LIMITS OF -20 TO +10
	SSB,RSS	
	JMP OFR	
	LDA OFRF	RESET OFRF BIT
	CMA	
	CLB	
	JSB SFLAG	RESET BIT
NVCF	LDA POWER	
	CMA,INA	
	ADA IDBMD	GET ERROR
	STA PWER	SAVE
	JSB .MPY	NEW VC
	DEF VCF	
	SSA	
	ARS	DIVIDE BY 2 IF NEG.
	STA VC	
	LDA PWER	



	SSA	ABSOLUTE VALUE
	CMA, INA	
	ADA PLEL	MINUS LIMIT
	CLS	
	SSA, RSS	
	LDB PEF	
	LDA PEF	
	CMA	
	JSB SFLAG	SET ERROR BIT
	LDA VC	
	ADA VOFST	NEW VOLTAGE
	JSB TVOLT	TEST FOR LIMITS
	STA VOFST	
	JSB VOUT	OUTPUT VOLTAGE
EXIT	LDB BR	RESTORE REGISTERS
	LDA ER	
	CLO	
	SLA, ELA	
	STC	
I010	LDA AR	
	STC PMS, C	ARM. POWER METER
	JMP CONT, I	EXIT
OFR	LDA PEF	OUT OF RANGE
	ADA OFRF	
	STA 1	
	CMA	
	JSB SFLAG	SET ERROR BITS
	JMP EXIT	
EXACT	LDA PEF	
	ADA OFRF	
	CMA	
	CLB	
	JSB SFLAG	SET FLAGS GOOD
	JMP EXIT	
	SKP	
SFB	NOP	SET BAD
	LDA PEF	
	ADA OFRF	
	STA 1	
	CMA	
	JSB SRFLR	
	JMP SFB, I	
	SPC 2	
GPTL	NOP	ENTRY, GET AND TEST POWER
	JSB .DLD	
	DEF IPWR, I	
	JSB .FMP	
	DEF D10.0	
	JSB IFIX	
	STA 1	
	ADB D150	TEST FOR -15 TO +3 RANGE
	SSB	
	LDA M150	
	LDB 0	
	ADB M30	
	SSS, RSS	
	LDA D30	
	JMP GPTL, I	EXIT

```

TVOLT SKP
NOP ENTRY TEST VOLTAGE
STA VLTS SAVE
STA 1
ADB VHLIM
SSB
LDA VLLIM
LDB 0
ADB VLLIM
SSB,RSS
LDA VHLIM
CPA VLTS TEST FOR CHANGE
JMP TVOLT,I GOOD, EXIT
LDB VLTS
CMB,INB
ADB 0
ADB VC
STB VC SET NEW VOLTAGE CHANGE
JMP TVOLT,I
SPC 2
VOUT NOP ENTRY, OUTPUT VOLTAGE
LDB WRD2
I011 CLC DVS,C
I012 OTA DVS
I013 OTB DVS
LDB M625
I014 SFC DVS WAIT TILL DONE
JMP VOUT,I
INB,SZB
JMP *-3
JMP VOUT+1
SPC 2
* DATA AND STORAGE
SPC 2
VCF DEC 20
D2000 DEC 2000.002
HVLIM DEC 16000
LVLIM DEC -16000
D13 DEC 13
D200 DEC 200
M100 DEC -100
PEF DEC 1
OFRF DEC 2
D10.0 DEC 10.0
D150 DEC 150
M150 DEC -150
D30 DEC 30
M30 DEC -30
VHLIM DEC 10000
VLLIM DEC -10000
PLEL DEC -2
WRD2 OCT 0100
M625 DEC -625
B4 OCT 4
IDBMD BSS 1
LPR BSS 1
VOFST BSS 1
VC BSS 1

```

```

AR      BSS 1
BR      BSS 1
ER      BSS 1
POWER   BSS 1
PWER    BSS 1
VLTS    BSS 1
BCDTB   NOP
        CMB, INB
        STB CTR
        LDB DTABL
        STB PTR
        CLB
LOOP    SLA
        ADB PTR, I
        CLE, ERA
        ISZ PTR
        ISZ CTR
        JMP LOOP
        SLA
        CMB, INB
        LDA 1
        JMP BCDTB, I
TABLE  DEC 1, 2, 4, 8, 10, 20, 40, 80, 100, 200, 400, 800
        DEC 1000, 2000, 4000, 8000
DTABL   DEF TABLE
PTR     BSS 1
CTR     BSS 1
SFLAG   NOP          ENTRY
        STA  TMPSTR
I015    LIA  FLAGR
        AND  TMPSTR
        ADA  1
I016    OTA  FLAGR
        JMP  SFLAG, I    EXIT
TMPSTR  BSS 1
        END

```



APPENDIX IV

Schematics of hardware designed at NRL specially tailored towards L-band transceiver test.

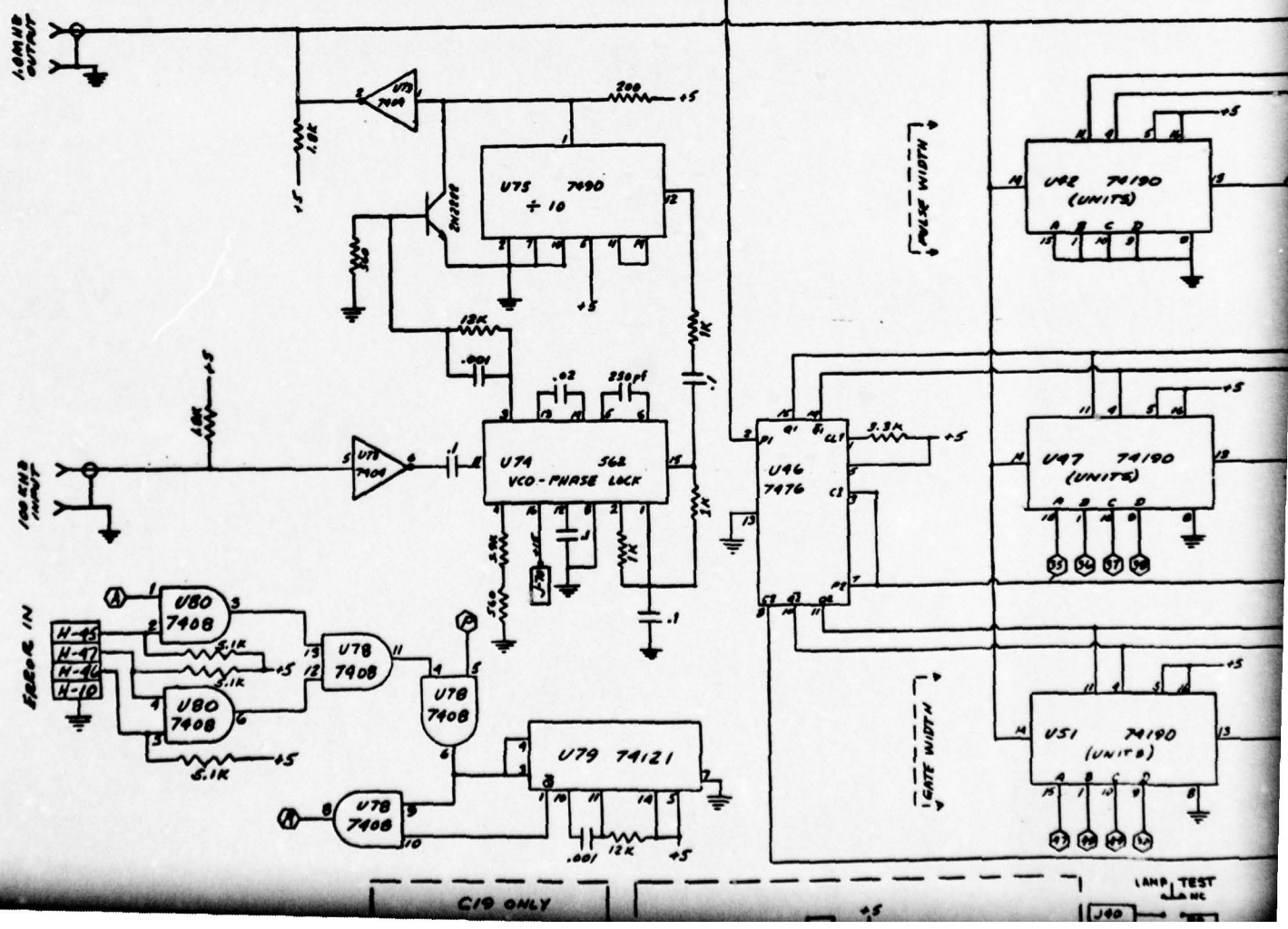
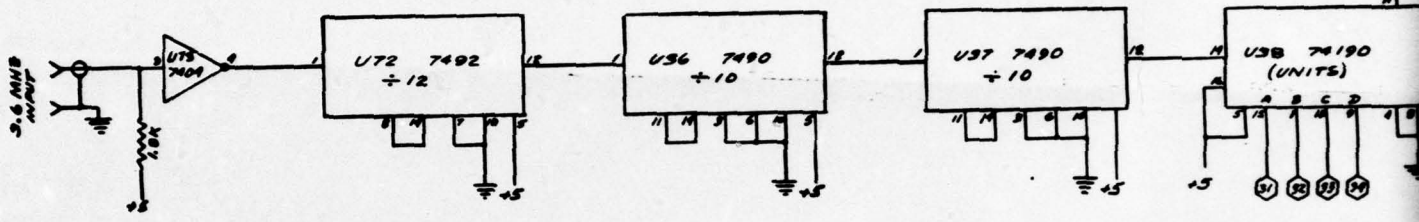
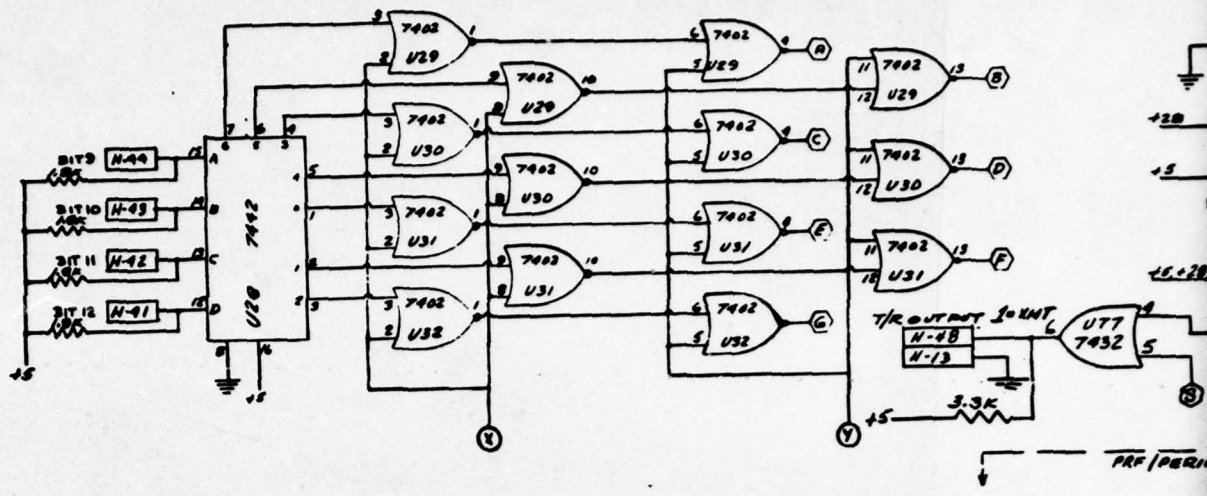

2

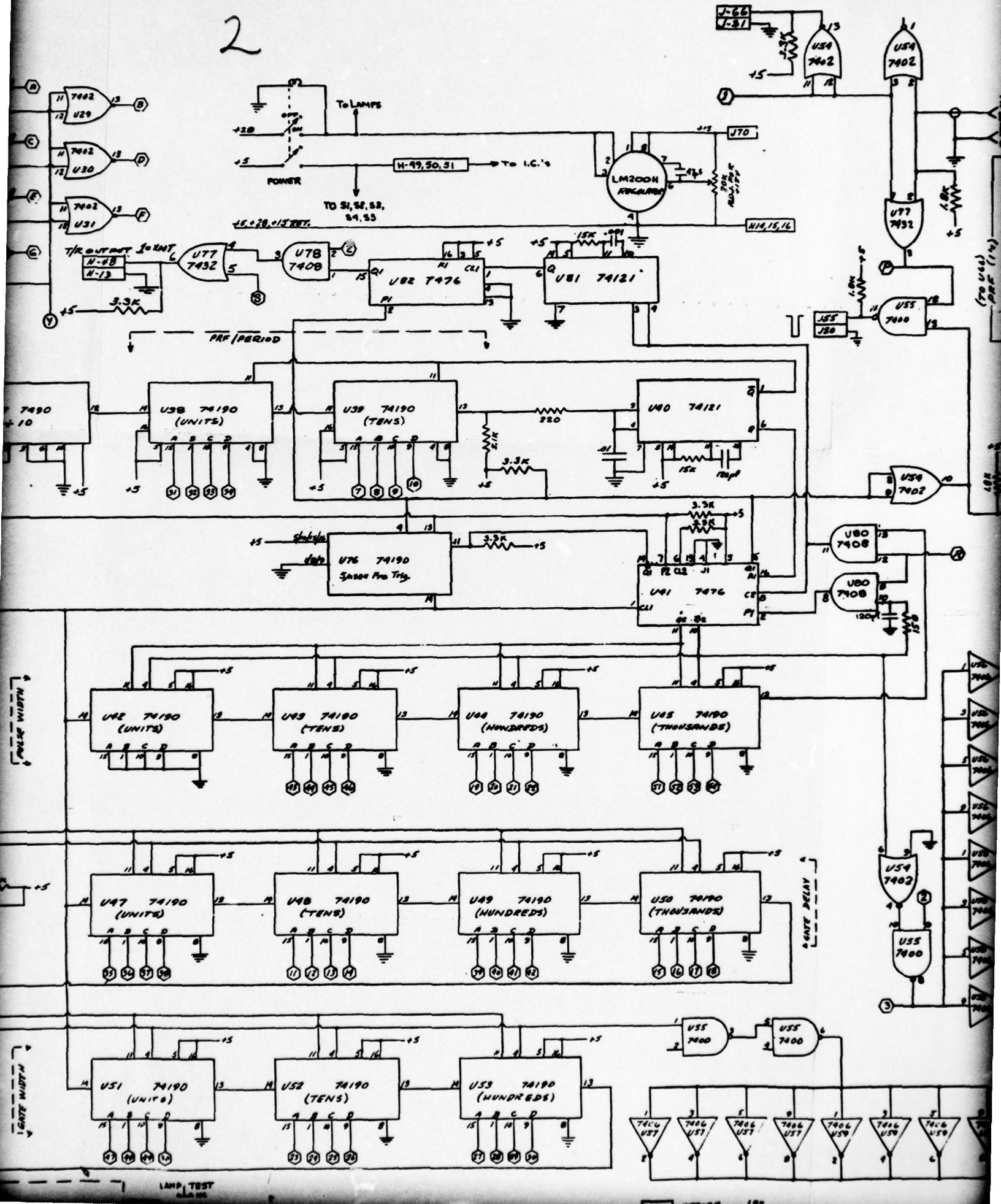



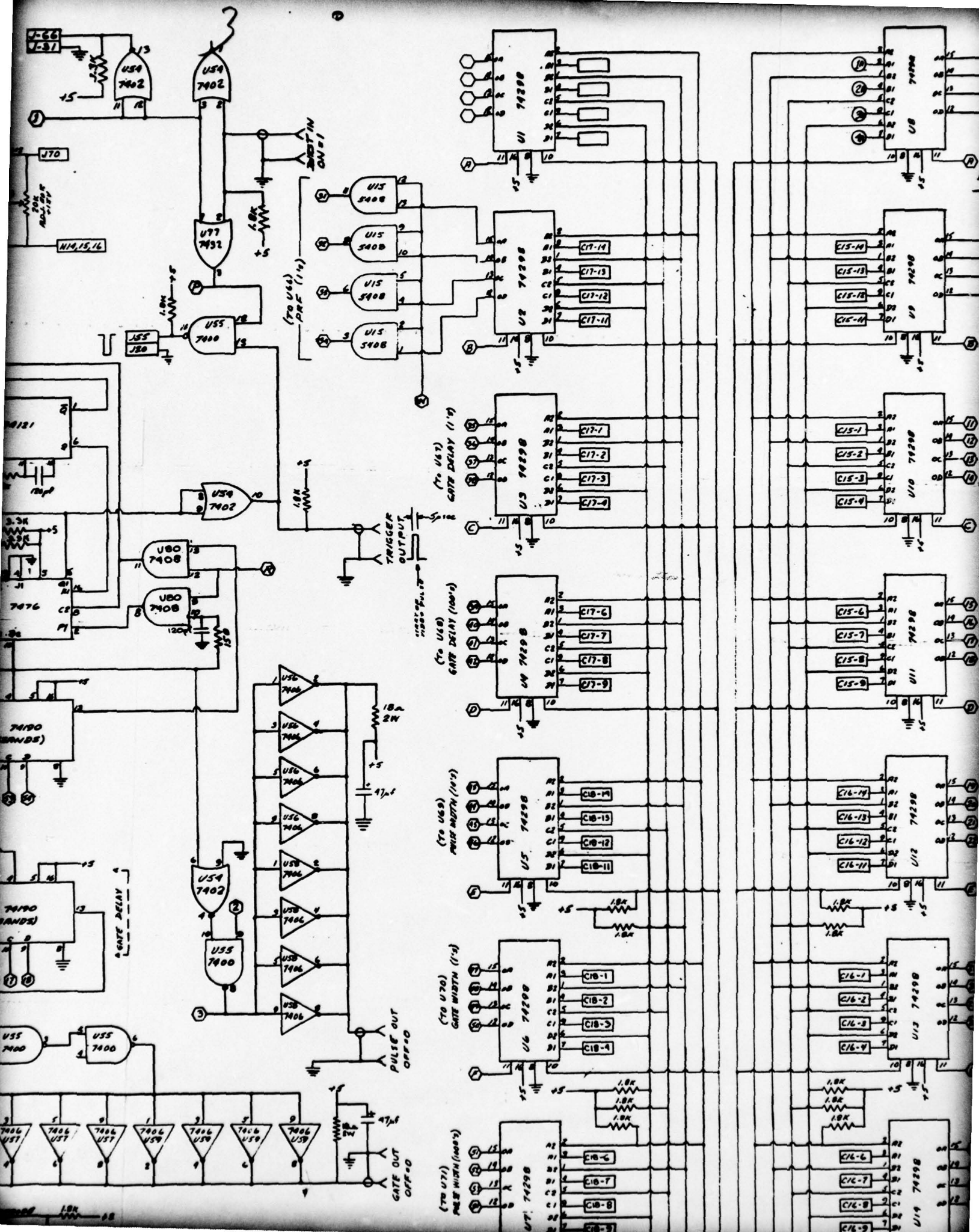

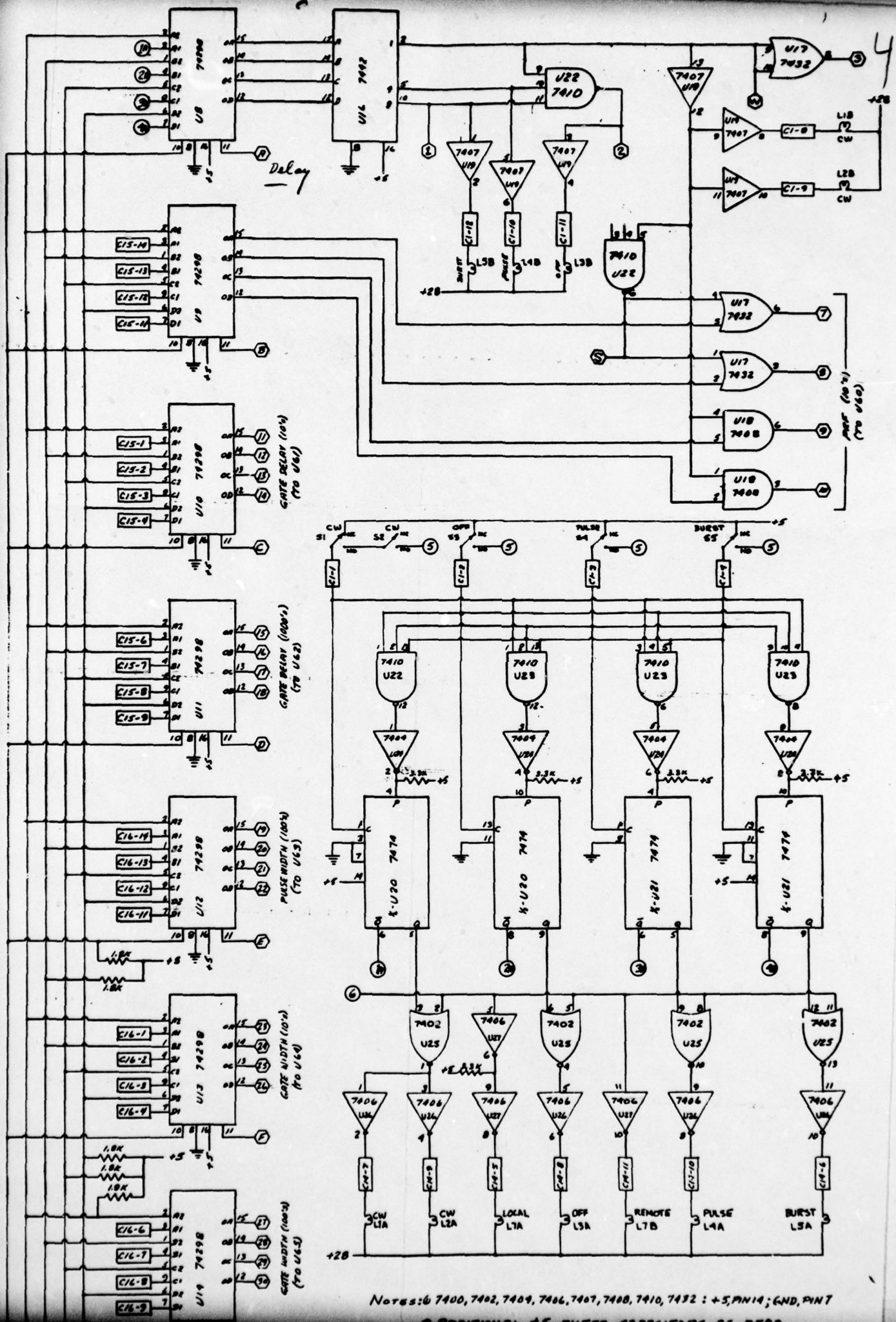

Notes: 6 7400, 7402, 7404, 7406, 7407, 7408, 7410, 7432 : +5, P14; GND, P17  
 ① ADDITIONAL +5 FILTER CAPACITORS AS REQD

5

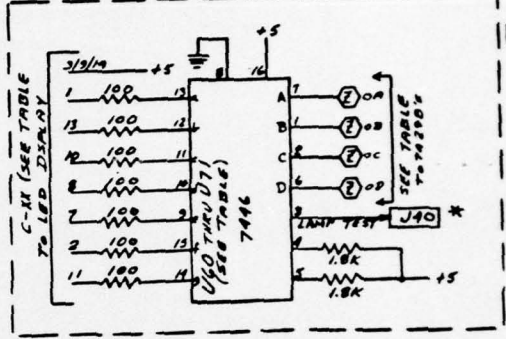
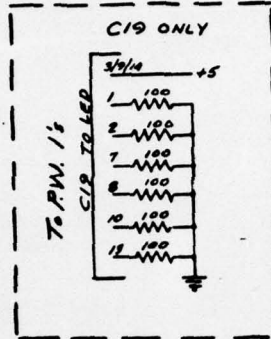
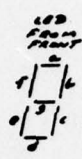
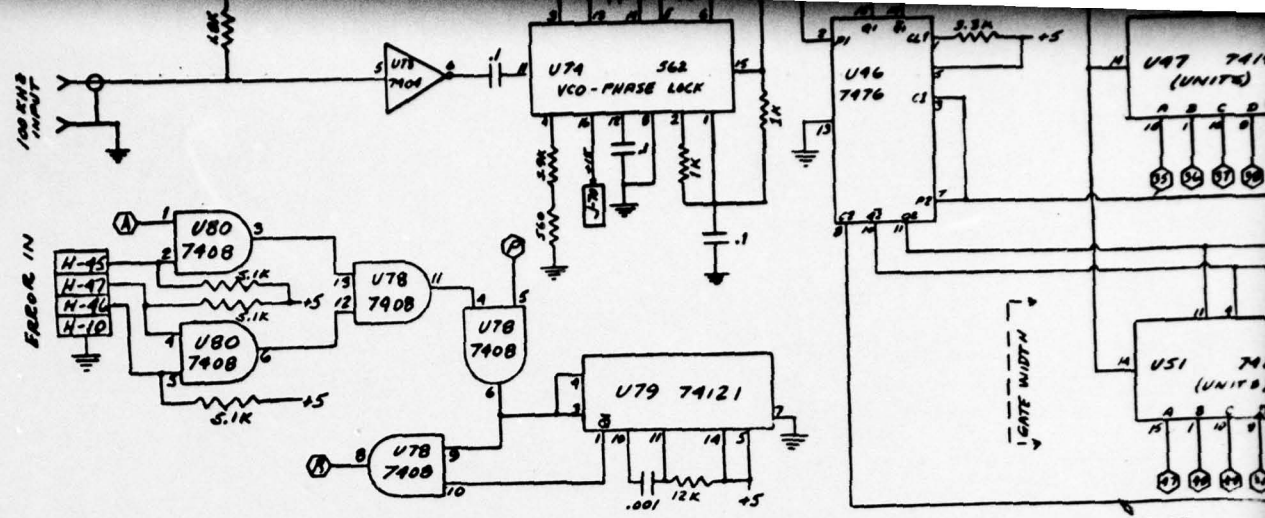



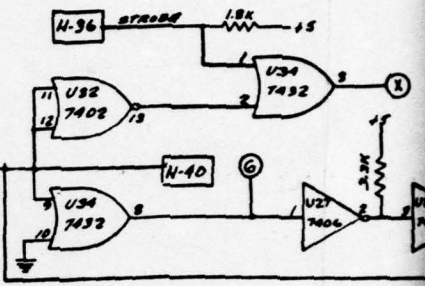
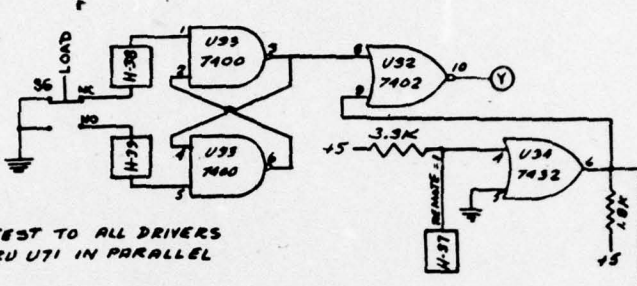
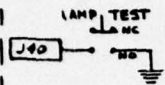
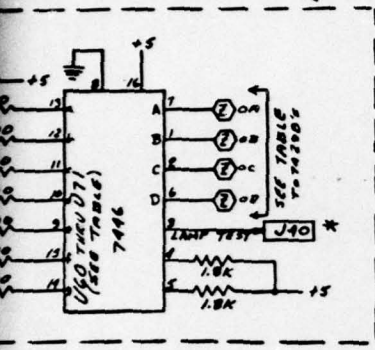
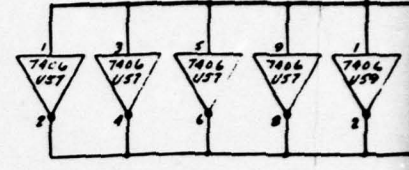
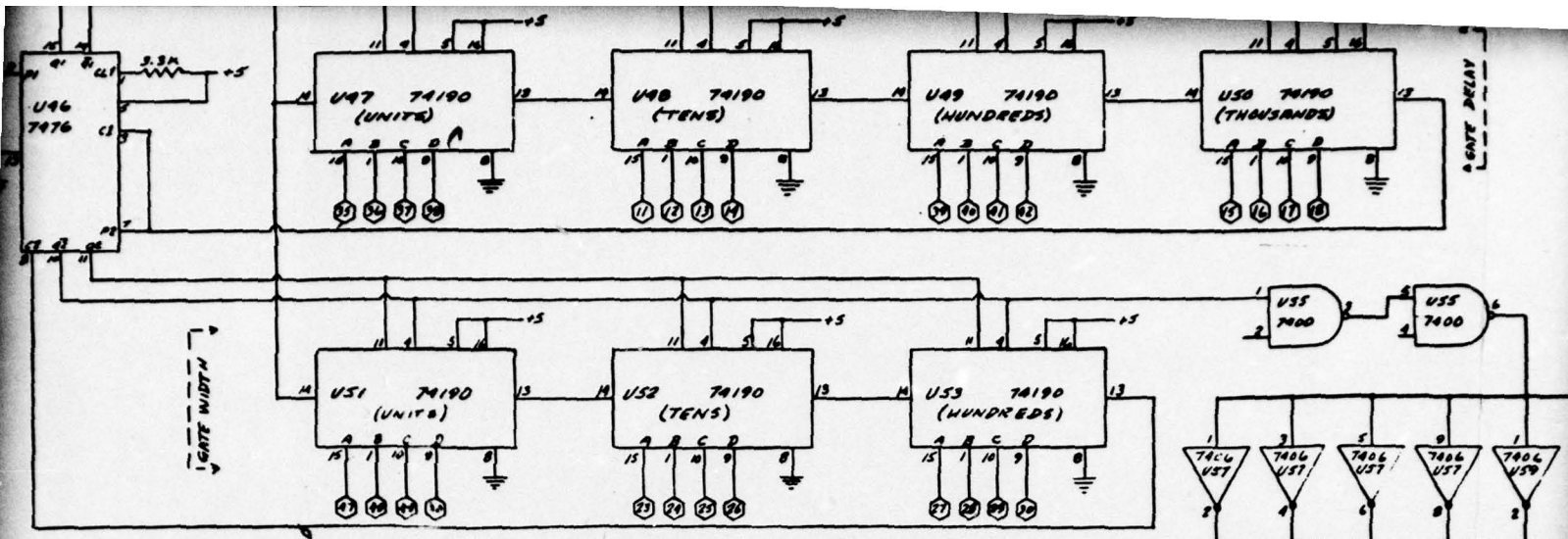

6

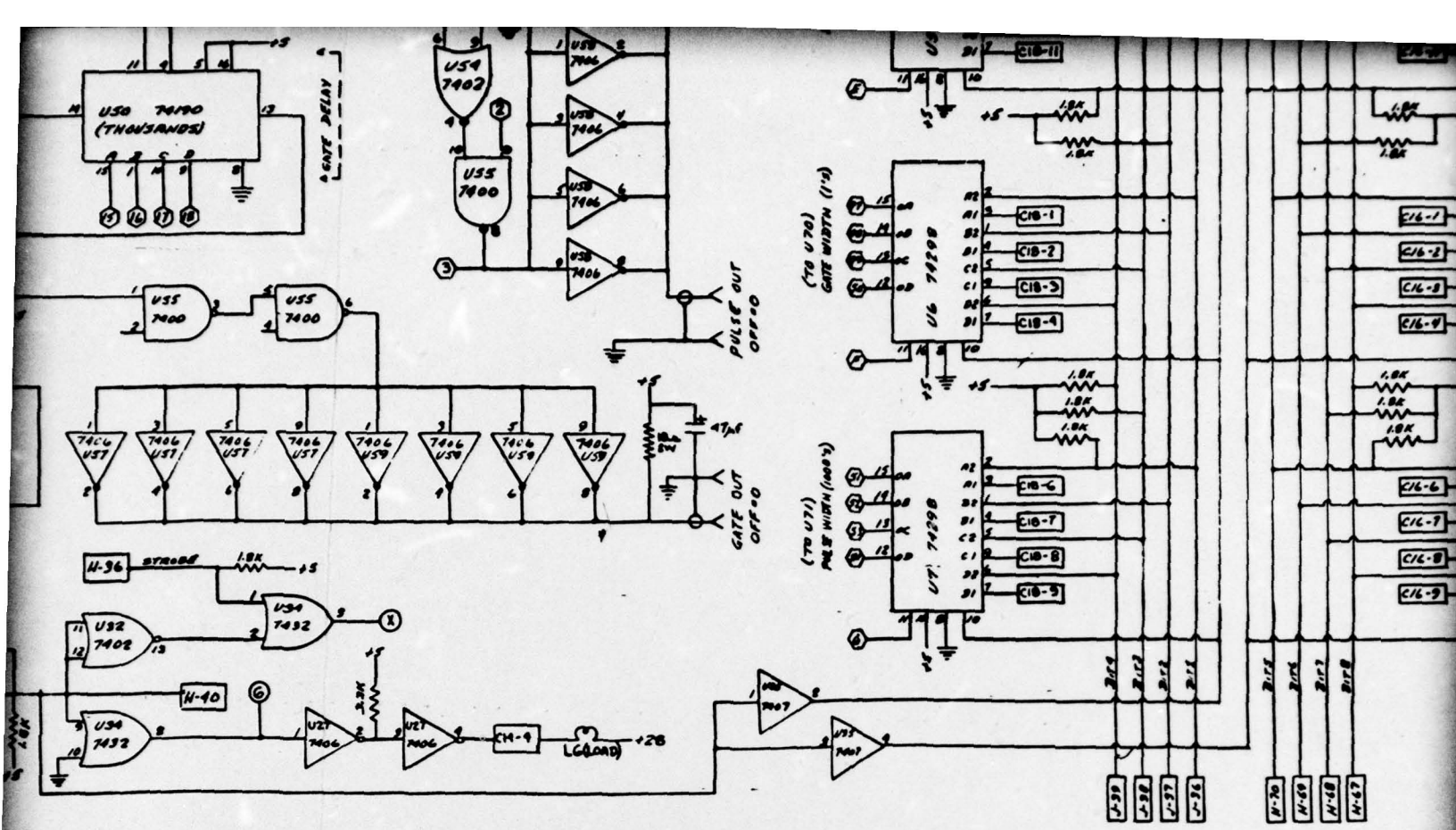

7 61  
 (Page 62 Blank)

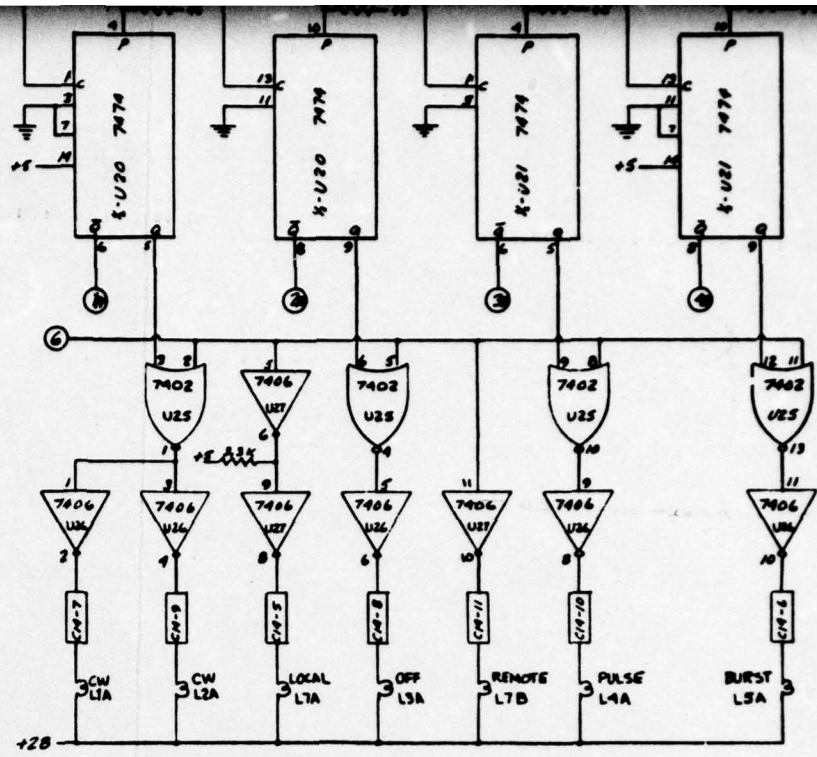
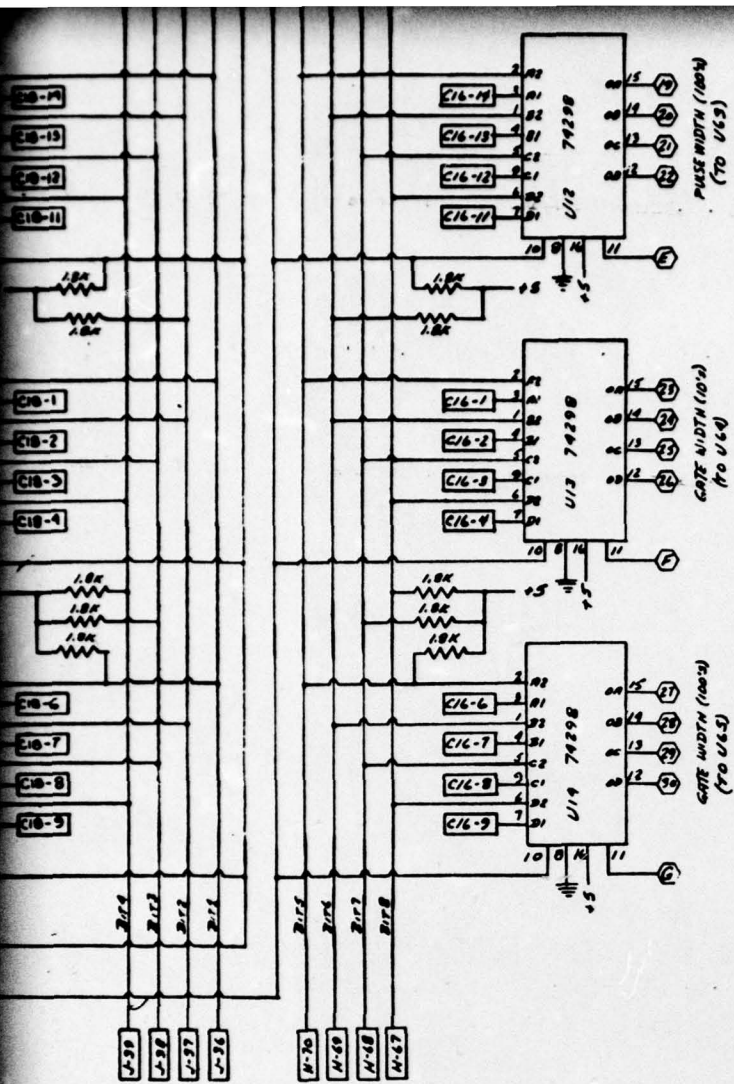

NOTES: ① 7400, 7402, 7409, 7406, 7407, 7408, 7410, 7412 : +5, PIN 14; GND, PIN 7  
 ② ADDITIONAL +5 FILTER CAPACITORS AS REQD  
 ③ LED DISPLAY NUMBERING SAME AS FS APPROPRIATE  
 "C" PIN NUMBERS

## PULSE GENERATOR

8



Pulse Generator (Continued)

**TABLE 1 LED DISPLAY**

U#	INPUTS				FROM	OUTPUTS TO	VIA
	A	B	C	D			
U-61	11	12	13	14	U-10	G.D. 10's	C-3
U-62	15	16	17	18	U-11	G.D. 1000's	C-4
U-63	19	20	21	22	U-12	P.W. 100's	C-5
U-64	23	24	25	26	U-13	G.W. 10's	C-6
U-65	27	28	29	30	U-14	G.W. 100's	C-7
U-66	31	32	33	34	U-15	PRF 1's	C-13
U-67	35	36	37	38	U-3	G.D. 1's	C-12
U-68	39	40	41	42	U-4	G.D. 100's	C-11
U-69	43	44	45	46	U-5	P.W. 10's	C-10
U-70	47	48	49	50	U-6	G.W. 1's	C-9
U-71	51	52	53	54	U-7	P.W. 1000's	C-8
U-60	7	8	9	10	U7 & U8	PRF 10's	C-2

**COMPUTER INPUTS**

BITS							
(1)	(2)	(3)	(4)	(1)(2)(3)(4)	(1)(2)(3)(4)		
9	10	11	12	1,2,3,4	5,6,7,8		
0	0	0	0	P.W. 10's	P.W. 100's		
1	0	0	0	G.W. 1's	G.W. 10's		
0	1	0	0	P.W. 1000's	G.W. 100's		
1	1	0	0	G.D. 1's	G.D. 10's		
0	0	1	0	G.D. 100's	G.D. 1000's		
1	0	1	0	PRF 1's	PRF 10's		
0	1	1	0	<del>X</del>	SEE MODE TABLE		

**MODE INPUTS**

BITS				MODE FUNCTION	WITH BITS 9,10,11,12 SET AS ABOVE
5	6	7	8		
0	0	0	1	BURST	<b>NOTES:</b> 1. FOR CW: TRIGGER OUTPUT COUNTS DOWN BY 30 TRIGGER PRF = 100 2. ALL OTHER THAN BURST-PULSE-CW YIELDS OFF
0	1	0	0	OFF	
0	0	1	0	PULSE	
1	0	0	0	CW	

Pulse Generator (Continued)

CIRCUIT BOARD

TOP VIEW

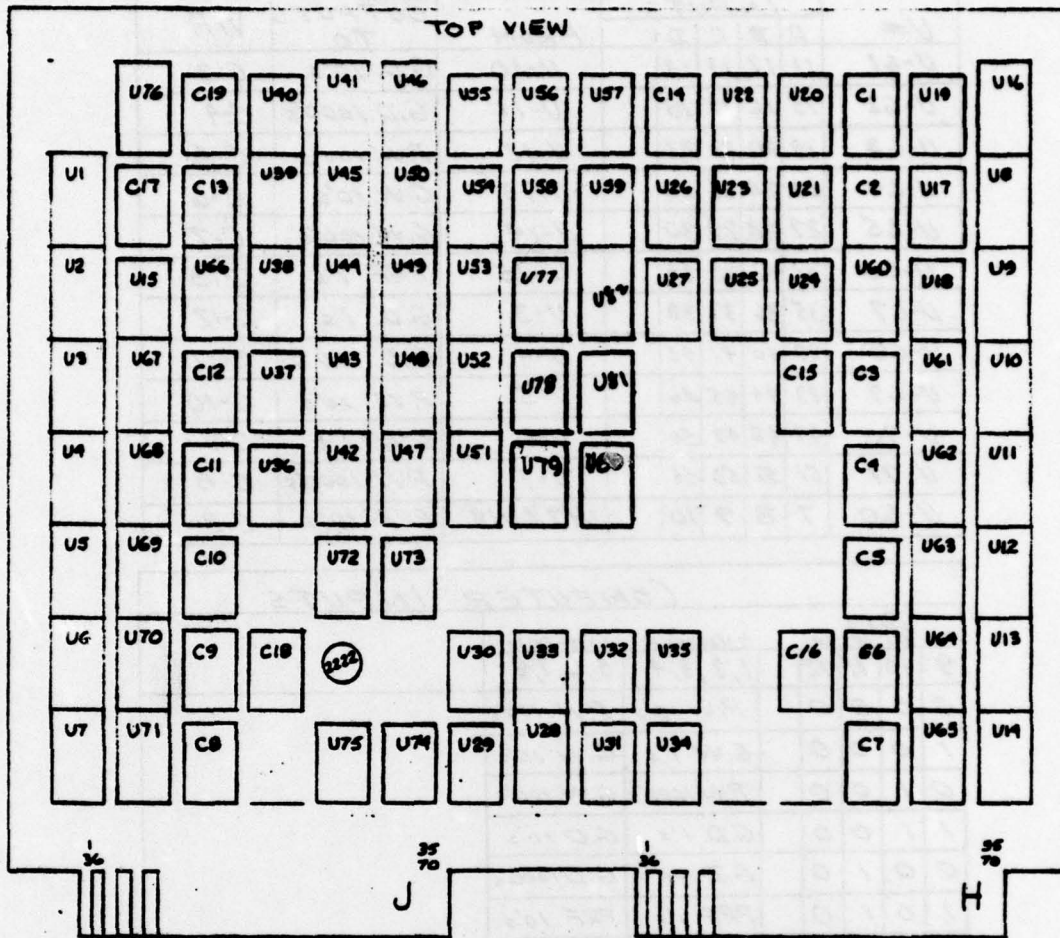

Note: Connectors C1-18 notch end (yellow/orange wires) is Pin 1 end.

COMPUTER CONNECTOR

PIN	FUNCTION	To	ALL GROUNDS TIED TO PIN 18 ON COMPUTER CABLE	PIN	FUNCTION	To	ALL GND'S PIN 18 ON COMPUTER CABLE
19	BIT 1	J-36		23	BIT 5	H-70	
20	BIT 2	J-37		24	BIT 6	H-69	
21	BIT 3	J-38		25	BIT 7	H-68	
22	BIT 4	J-39		26	BIT 8	H-67	
27	BIT 9	H-44		29	BIT 11	H-42	
28	BIT 10	H-43		30	BIT 12	H-41	
35	LOCAL/REMOTE Pin 1	H-37		36	STRAP	H-36	
34	TEST LOGIC OUT	J-62					
33	TEST OUT	J-55					
14	ERROR IN	H-45					
13	ERROR IN	H-46					
32	ERROR IN	H-47					
31	TEST IN-OUT	H-48					

TP = TWISTED PAIR

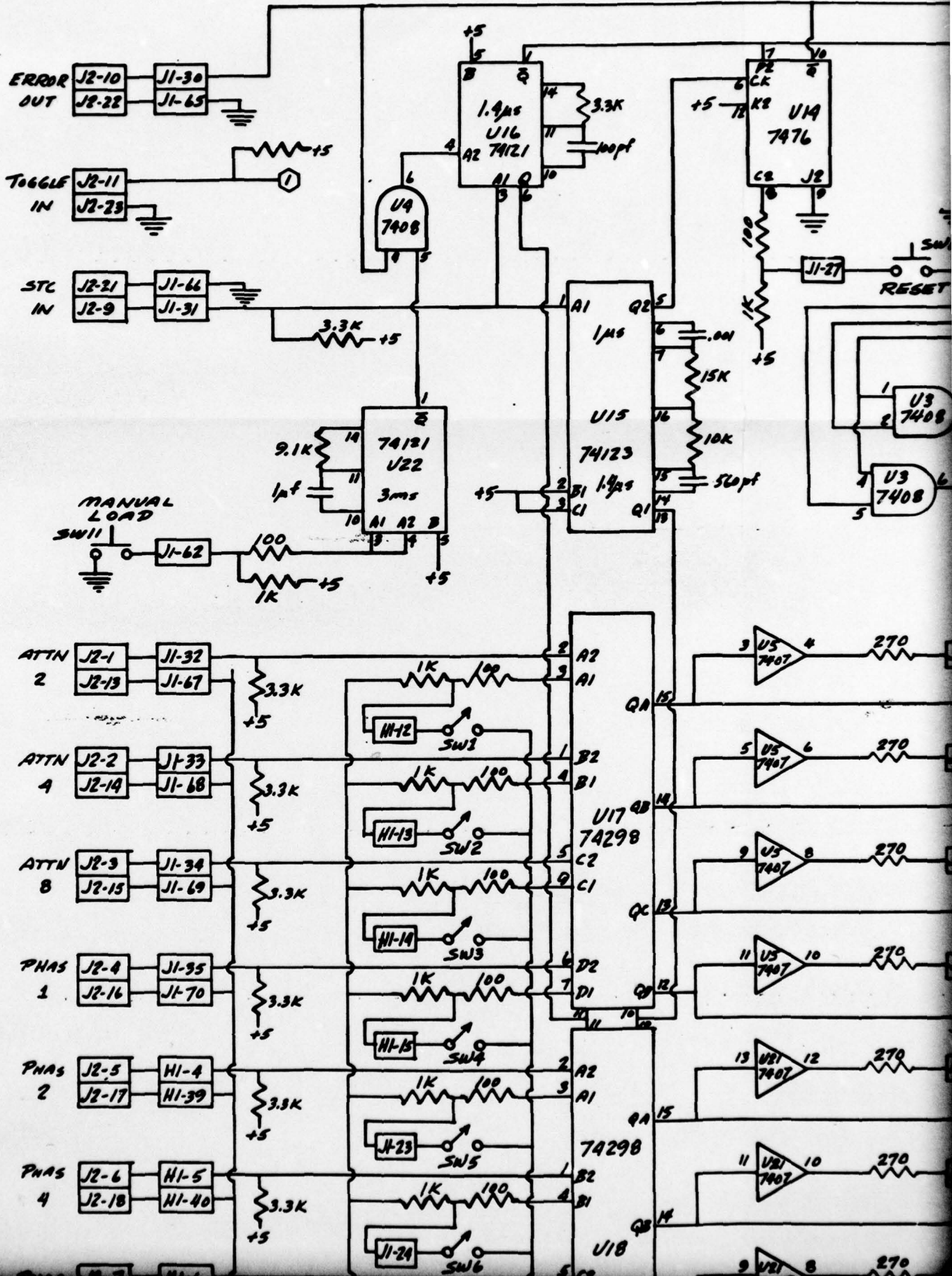



2

NADC TRANS INTERFACE

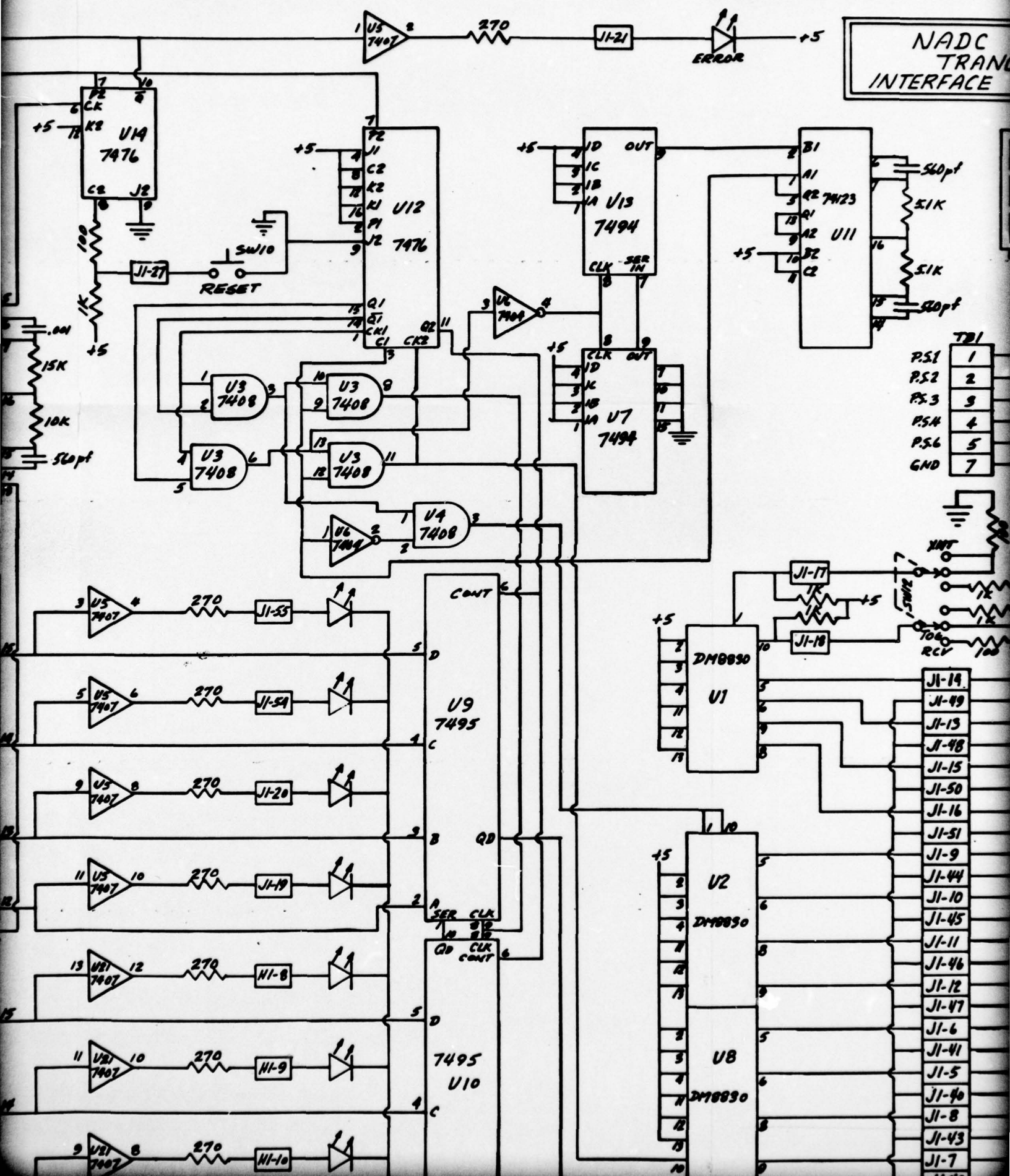

TBI	1
P.S.1	2
P.S.2	3
P.S.3	4
P.S.4	5
P.S.6	6
GND	7

J1-14	1
J1-49	2
J1-13	3
J1-48	4
J1-15	5
J1-50	6
J1-16	7
J1-51	8
J1-9	9
J1-44	10
J1-10	11
J1-45	12
J1-11	13
J1-46	14
J1-12	15
J1-47	16
J1-6	17
J1-41	18
J1-5	19
J1-40	20
J1-8	21
J1-43	22
J1-7	23

# NADC L-BAND TRANCEIVER INTERFACE & CONTROL

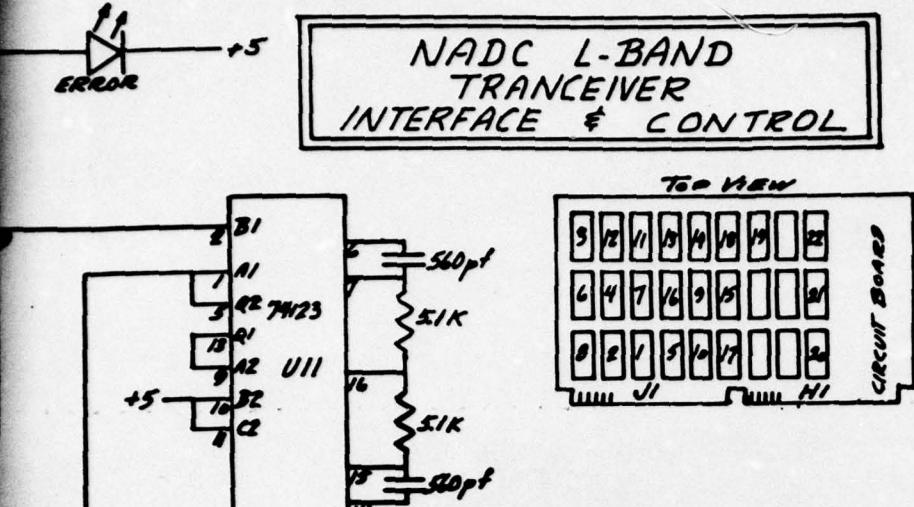

PS1	1	F-17
PS2	2	
PS3	3	F-41
PS4	4	F-50
PS6	5	F-40
GND	7	F-45

TO TRANCEIVER

DC POWER

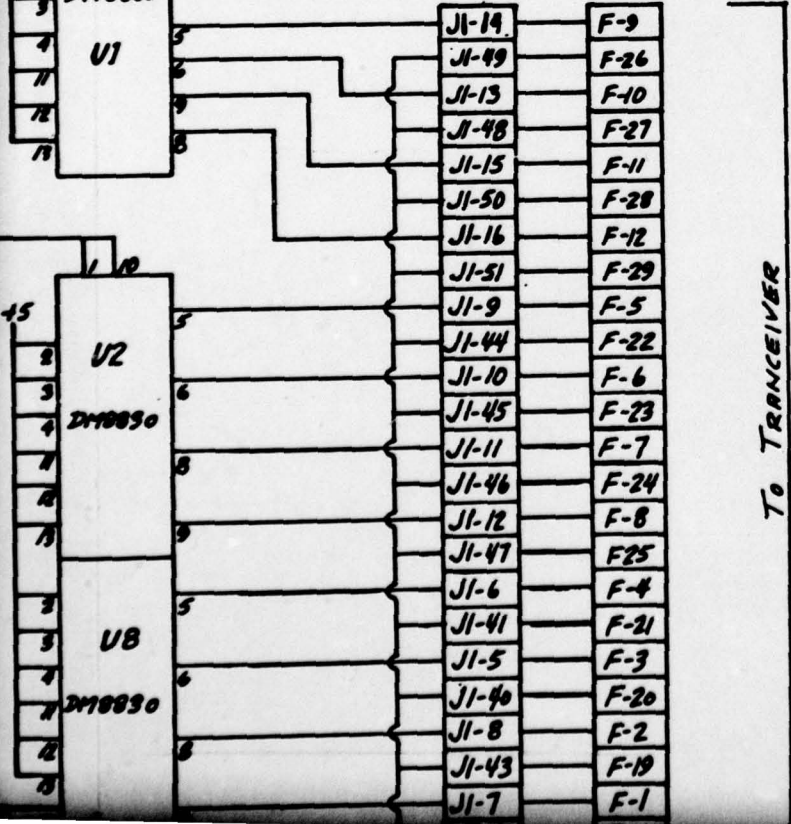
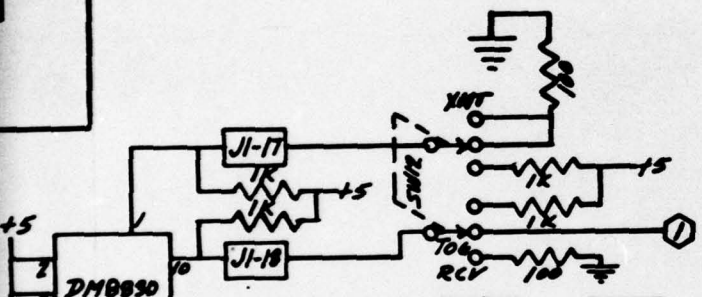

TO TRANCEIVER

CLASS "A" T/R

PHASE ATTN. TRANSFER TRANSFER ENABLE

SERIAL DATA

CLOCK

4

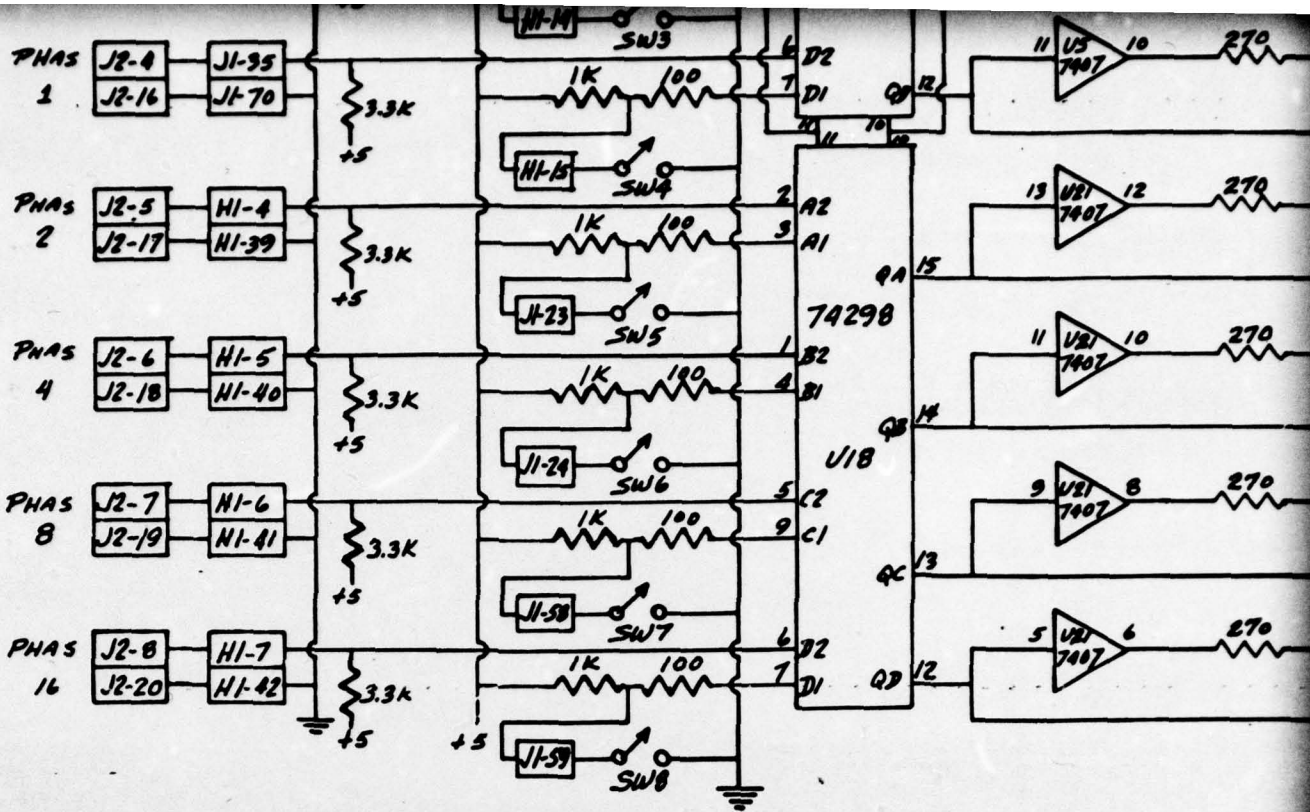



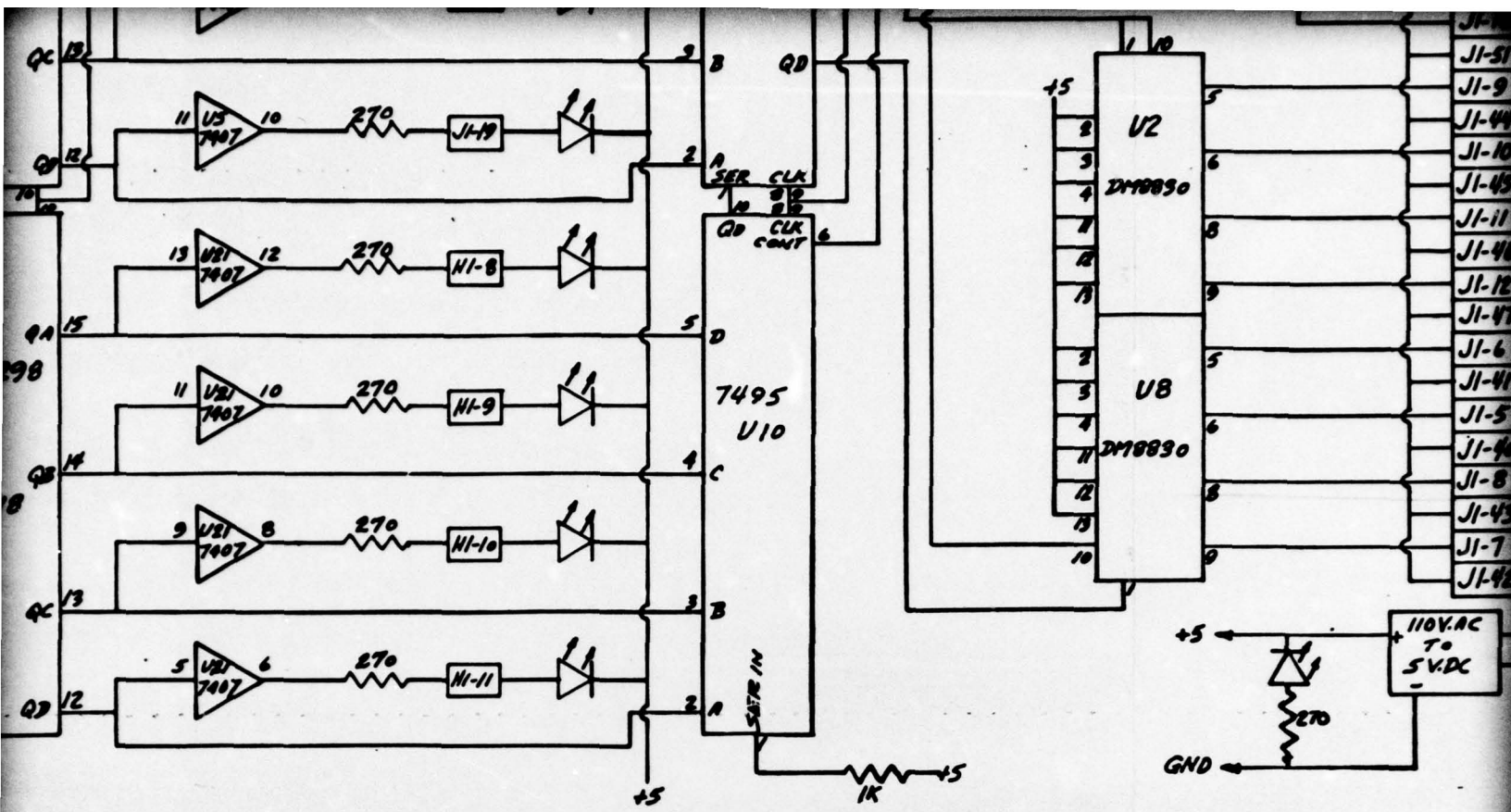

5 65  
 (Page 66 Blank)

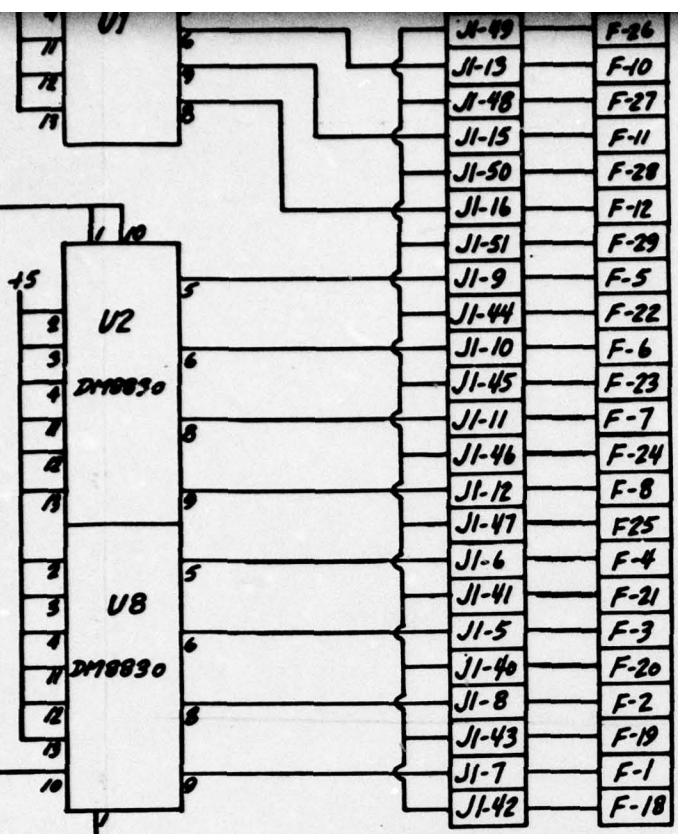

TO TRANCEIVER

CLOCK	SERIAL DATA	PHASE TRANSFER	ATTN. TRANSFER	CLASS "A"	T/R
				ENABLE	

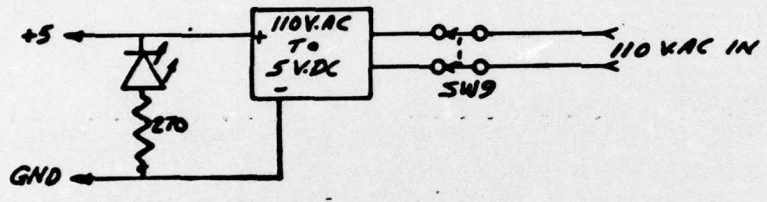

6