

12

ADA 048635

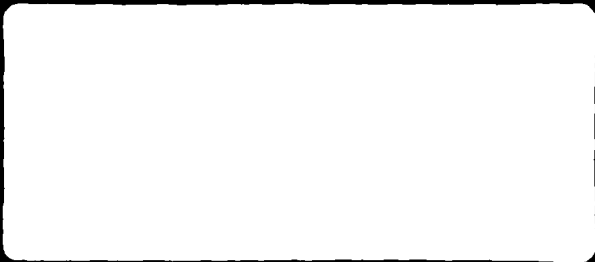

DDC
RECEIVED
JAN 12 1978
RECEIVED
B

NO. _____
DDC FILE COPY

DISTRIBUTION STATEMENT A
Approved for public release;
Distribution Unlimited



ADAMS

DISCLAIMER NOTICE

THIS DOCUMENT IS BEST QUALITY PRACTICABLE. THE COPY FURNISHED TO DTIC CONTAINED A SIGNIFICANT NUMBER OF PAGES WHICH DO NOT REPRODUCE LEGIBLY.

TECHNICAL REPORT
1245.5-B

12

See 1473

REMBASS
COMMANDABILITY
TRADE OFF ANALYSIS (TOA)
TRADE OFF DETERMINATION (TOD)

Submitted to:
PMO Remotely Monitored
Battlefield Sensor Systems
Ft. Monmouth, N.J. 07703

15 December 1977

Contract #DAAB07-77D-6386

DDC
RECEIVED
JAN 12 1978
B

Prepared by the Staff of Analytics

Delmar G. Baker

Delmar G. Baker
Project Leader

use 388996

ANALYTICS

766 SHREWSBURY AVENUE, NEW SHREWSBURY, NEW JERSEY 07724

DISTRIBUTION STATEMENT A
Approved for public release;
Distribution Unlimited



TABLE OF CONTENTS

| | | |
|---|--|-----|
| EXECUTIVE SUMMARY..... | | i |
| I. INTRODUCTION..... | | 1-1 |
| 1.1 Objective..... | | 1-1 |
| 1.2 Basic REMBASS Description..... | | 1-2 |
| II. SENSOR DESCRIPTION..... | | 2-1 |
| 2.1 General..... | | 2-1 |
| 2.2 Detection Sensors Only..... | | 2-1 |
| 2.2.1 Sensor, Anti-Intrusion DT-561 ()..... | | 2-1 |
| 2.2.2 Sensor, Anti-Intrusion DT-565 ()..... | | 2-2 |
| 2.3 Classification Sensors..... | | 2-2 |
| 2.3.1 Sensor, Anti-Intrusion DT-562 ()..... | | 2-2 |
| 2.3.2 Sensor, Anti-Intrusion DT-567 ()..... | | 2-3 |
| 2.3.3 Sensor, Anti-Intrusion DT-570 ()..... | | 2-5 |
| 2.3.4 Sensor, Anti-Intrusion DT-573 ()..... | | 2-4 |
| 2.3.5 Sensor, Analog DT-563 ()..... | | 2-4 |
| 2.3.6 Imaging Sensor..... | | 2-4 |
| III. RADIO REPEATER DESCRIPTION..... | | 3-1 |
| 3.1 General..... | | 3-1 |
| 3.2 Repeater, Radio RT-1175 ()..... | | 3-1 |
| 3.3 Repeater, Radio RT-1200 ()..... | | 3-2 |
| 3.4 Repeater, Radio RT-1201 ()..... | | 3-2 |
| IV. RECEIVING AND MONITORING EQUIPMENT..... | | 4-1 |
| 4.1 General..... | | 4-1 |
| 4.2 Antenna Group OE-239 ()..... | | 4-1 |
| 4.3 Sensor Monitoring Set AN/GSQ-187 ()..... | | 4-2 |
| 4.4 Portable Monitoring Set R-2016 ()..... | | 4-2 |

| | | |
|---------------------------------|---------------|-------------------------------------|
| Approved for | | |
| GNS | White Section | <input checked="" type="checkbox"/> |
| BDC | Buff Section | <input type="checkbox"/> |
| UNANNOUNCED | | <input type="checkbox"/> |
| JUSTIFICATION _____ | | |
| BY _____ | | |
| DISTRIBUTION/AVAILABILITY CODES | | |
| Dist. | AVAIL. and/or | SP. CIAL |
| A | | |

TABLE OF CONTENTS (Cont'd)

| | | |
|-------|--|------|
| V. | COMMAND EVALUATION..... | 5-1 |
| 5.1 | General..... | 5-1 |
| 5.1.1 | Objectives and Alternatives..... | 5-2 |
| 5.2 | Command Functions..... | 5-3 |
| 5.2.1 | DT-563 Seismic/Analog Sensor..... | 5-4 |
| 5.2.2 | Proposed D-563 Analog Duty Cycle..... | 5-4 |
| 5.2.3 | Remote Imaging Sensor..... | 5-4 |
| 5.2.4 | Command Potential for All Sensors..... | 5-8 |
| 5.3 | Measures of Effectiveness..... | 5-16 |
| 5.3.1 | DT-563 Measure of Effectiveness..... | 5-16 |
| 5.3.2 | Other Type I Sensors..... | 5-18 |
| 5.4 | Advance REMBASS Commandability..... | 5-18 |
| 5.4.1 | Reprogrammable Microprocessors..... | 5-18 |
| 5.4.2 | Stay Behind and Dormat Sensors..... | 5-21 |
| VI. | ALTERNATIVES..... | 6-1 |
| 6.1 | General Description..... | 6-1 |
| 6.2 | Alternative Common Changes..... | 6-3 |
| 6.3 | Operational Description of Alternatives..... | 6-3 |
| 6.3.1 | Alternative 1..... | 6-3 |
| 6.3.2 | Alternative 2..... | 6-6 |
| 6.3.3 | Alternative 3..... | 6-9 |
| 6.3.4 | Alternative 4..... | 6-14 |
| 6.3.5 | Alternative 5..... | 6-14 |
| 6.3.6 | Alternative 6..... | 6-20 |
| 6.4 | Salient Features..... | 6-23 |
| VII. | ANALYSIS OF ALTERNATIVES..... | 7-1 |
| 7.1 | General..... | 7-1 |
| 7.1.1 | Sensor Weight and Weight Size/Cube..... | 7-2 |
| 7.1.2 | Command Transmitter Weight and Size/Cube... | 7-3 |
| 7.1.3 | Sensor Monitor Set Weight and Size/Cube.... | 7-3 |
| 7.2 | Alternative 1..... | 7-3 |
| 7.2.1 | Cost Impact..... | 7-3 |
| 7.2.2 | Logistic Support..... | 7-6 |
| 7.2.3 | Performance..... | 7-6 |
| 7.2.4 | RAM Impact..... | 7-6 |
| 7.2.5 | Other Considerations..... | 7-7 |

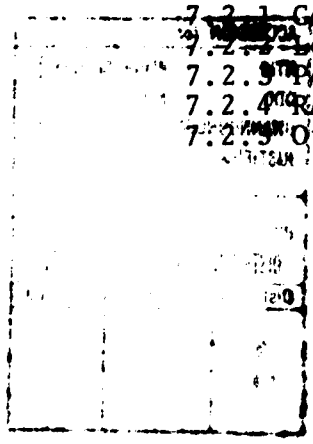

TABLE OF CONTENTS (Cont'd)

| | | |
|-------|--|------|
| 7.3 | Alternative 2..... | 7-8 |
| | 7.3.1 Cost Impact..... | 7-8 |
| | 7.3.2 Logistic Support..... | 7-10 |
| | 7.3.3 Performance..... | 7-10 |
| | 7.3.4 RAM Impact..... | 7-11 |
| | 7.3.5 Other Considerations..... | 7-11 |
| 7.4 | Alternative 3..... | 7-11 |
| | 7.4.1 Cost Impact..... | 7-12 |
| | 7.4.2 Logistic Support..... | 7-12 |
| | 7.4.3 Performance..... | 7-15 |
| | 7.4.4 RAM Impact..... | 7-15 |
| | 7.4.5 Other Considerations..... | 7-15 |
| 7.5 | Alternative 4..... | 7-16 |
| | 7.5.1 Cost Impact..... | 7-16 |
| | 7.5.2 Logistic Support..... | 7-18 |
| | 7.5.3 Performance..... | 7-18 |
| | 7.5.4 RAM Impact..... | 7-19 |
| | 7.5.5 Other Considerations..... | 7-19 |
| 7.6 | Alternative 5..... | 7-20 |
| | 7.6.1 Cost Impact..... | 7-20 |
| | 7.6.2 Logistics Support..... | 7-22 |
| | 7.6.3 Performance..... | 7-22 |
| | 7.6.4 RAM Impact..... | 7-23 |
| | 7.6.5 Other Considerations..... | 7-23 |
| 7.7 | Alternative 6..... | 7-24 |
| | 7.7.1 Cost Impact..... | 7-24 |
| | 7.7.2 Logistic Support..... | 7-26 |
| | 7.7.3 Performance..... | 7-26 |
| | 7.7.4 RAM Impact..... | 7-26 |
| | 7.7.5 Other Considerations..... | 7-27 |
| 7.8 | Summary of Analysis..... | 7-27 |
| VIII. | RECOMMENDATION..... | 8-1 |
| | 8.1 Recommended Alternative..... | 8-1 |
| | 8.2 Evaluation Methodology..... | 8-1 |
| | 8.3 Alternative Comparison..... | 8-3 |
| | 8.4 Discussion of Recommended Alternative..... | 8-3 |

LIST OF APPENDICES

APPENDICES

- A. Cost Estimate
- B. Reliability Computations
- C. SEAOPSS Overview
- D. Sensor/Repeater Modification
- E. Timing Aspects of Analog Sensor DT-563
- F. References

LIST OF TABLES

| | | |
|----------|---|------|
| 5.2-1 | Acoustic Commands..... | 5-5 |
| 5.2-2 | Performance As a Function of Target and Times. | 5-7 |
| 5.2-3(a) | Imaging Sensors (Electronic Commands)..... | 5-9 |
| 5.2-3(b) | Imaging Sensors (Mechanical Commands)..... | 5-11 |
| 5.2-4 | Commands To Activate/Deactivate Individual or Groups of Sensors..... | 5-12 |
| 5.3-1 | Command Function vs. Operational Effectiveness DT-563..... | 5-17 |
| 5.3-2 | Command Function vs. Operational Effectiveness (Classifiers)..... | 5-19 |
| 7-1 | Cost Impact (Alternative 1)..... | 7-4 |
| 7-2 | Cost Impact (Alternative 2)..... | 7-8 |
| 7-3 | Cost Impact (Alternative 3)..... | 7-13 |
| 7-4 | Cost Impact (Alternative 4)..... | 7-16 |
| 7-5 | Cost Impact (Alternative 5)..... | 7-20 |
| 7-6 | Cost Impact (Alternative 6)..... | 7-24 |
| 7-7 | Summary Analysis of Alternates..... | 7-28 |
| 8-1 | Operational Enhancement Evaluation..... | 8-4 |

LIST OF FIGURES

| | | |
|------|--|------|
| 6-1A | Alternative 1..... | 6-4 |
| 6-1B | Alternative 1..... | 6-5 |
| 6-2A | Alternative 2..... | 6-7 |
| 6-2B | Alternative 2..... | 6-8 |
| 6-3A | Alternative 3..... | 6-10 |
| 6-3B | Alternative 3..... | 6-11 |
| 6-3C | Sensor InBand Relay System..... | 6-12 |
| 6-3D | Sensor InBand Relay System..... | 6-13 |
| 6-4A | Alternative 4..... | 6-15 |
| 6-4B | Alternative 4..... | 6-16 |
| 6-5A | Alternative 5..... | 6-18 |
| 6-5B | Alternative 5..... | 6-19 |
| 6-6A | Alternative 6..... | 6-21 |
| 6-6B | Alternative 6..... | 6-22 |
| 7-1 | Add On Component Breakdown(Alternative 1)..... | 7-5 |
| 7-2 | Add On Component Breakdown(Alternative 2)..... | 7-9 |
| 7-3 | Add On Component Breakdown(Alternative 3)..... | 7-14 |
| 7-4 | Add On Component Breakdown(Alternative 4)..... | 7-16 |
| 7-5 | Add On Component Breakdown(Alternative 5)..... | 7-21 |
| 7-6 | Add On Component Breakdown(Alternative 6)..... | 7-25 |

EXECUTIVE SUMMARY

SUMMARY

This trade-off analysis (TOA) and trade-off determination (TOD) was used to analyze and rank various system-level and contract end item (CEI) relationships to fulfill the commandability requirements stated in the REMBASS (Revised) Materiel Need (MN).

At the system level, six alternative configurations were examined. Technical, operational, tactical and management-level criteria was used as the means for determining measures of effectiveness (MOE) and included total system impact and the ability to support commandability in the field.

Employing Type I REMBASS system and hardware configurations as well as REMBASS in-band data transmission subsystem (DTS), the first-ranked alternative involves the following major elements:

- Repeaters employing a second, pre-programmed rf channel, which (upon receipt of the command message "header" switches from its normal (i.e., sensor message channel) to the second -- or command message channel. Upon completion of the command message transaction, the repeater automatically reverts back to the normal channel.

- The addition of receiver, frequency determining elements, decoder, transmit/receive switches to commandable sensors, and modifications to that sensor to cause it to respond to pre-determined commands.

CONCLUSION

That commandability represents an area of low technical risk and can be incorporated into Engineering Development (ED) REMBASS sensors and system. That its inclusion into the seismic/analog and imaging devices will materially enhance both performance of these sensors and extend system life and capabilities. That inclusion of commandability into all other sensors will, to a lesser degree, also enhance ED system performance and capability.

Commandability will add cost and some degree of complexity both to the system and the individual items of equipment. However, much of the system complexity could be eased

through station-keeping and watch-keeping functions in devices such as a Sensor Processing Unit (SPU) or through subsequent modifications to the micro-processor controlled Sensor Monitoring Set (SMS).

RECOMMENDATION

That ED REMBASS program objectives, procurement strategy, milestones, schedules and budget be critically evaluated to ascertain the most effective means and optimum time for incorporating command functions into (either) present or future system procurements.

I. INTRODUCTION

1.1 OBJECTIVE

The requirement for a command capability in the Remotely Monitored Battlefield Sensor System (REMBASS) was included in the initial Department of the Army approved Materiel Need (MN) for REMBASS, as well as in later revisions of the approved MN. Commandability is not included in the Basic REMBASS. The objective of the following detailed analysis is to:

- Determine the impact on REMBASS when adding commandability; i.e., performance, cost, operations, and ILS.
- Delineate the capabilities acquired by the system with the addition of Commandability.

- Determine the optimum method for including Commandability within REMBASS.

1.2 BASIC REMBASS DESCRIPTION

The Basic REMBASS is a tactical intelligence source system intended to provide military Commanders at Division, Brigade and Battalion echelons with early warning, surveillance and target acquisition information, regarding hostile activity in areas forward of the Forward Edge of Battle Area (FEBA) and for rear area protection within the Division Zone. The system has the ability to detect and classify the movement of tracked vehicles, wheeled vehicles, and personnel by use of seismic, acoustic, magnetic, infra-red and strain wire sensors in likely areas of enemy action. Information collected by the sensors is processed, arranged in message format and transmitted to the Sensor Monitoring Set or the Portable Monitoring Set either directly or by using radio repeater(s). Messages received at the Sensor Monitoring Set are demodulated, decoded, temporarily displayed, and permanently recorded. Messages received at the Portable Monitoring Set provide visual display of sensor identification and associated classifications. A description of each item of equipment follows.

II. SENSOR DESCRIPTION

2.1 GENERAL

A family of seven sensors are included in the Basic REMBASS requirement. Each of the sensors are described below.

2.2 Detection Only Sensors

The following sensors detect and provide other information on targets which move through the sensor's detection zone.

2.2.1 Sensor, Anti-Intrusion DT-561() GSQ is an expendable/recoverable hand emplaced, battery powered, magnetic detecting sensor. The sensor is self-contained and communicates either directly or through radio repeater(s). The sensor uses a passive magnetic technique to detect tracked vehicles, wheeled vehicles, and armed personnel targets. The sensor processes the response and provides detection informa-

tion. The information is incorporated within a digital message format and is transmitted to a distant Sensor Monitoring Set or Portable Monitor Set using the internal FM radio transmitter.

2.2.2 Sensor Anti-Intrusion DT-565 () GSQ is an expendable recoverable hand emplaced, battery operated, passive infrared (IR) detecting sensor. The sensor is self contained and communicates with the Sensor Monitoring Set or Portable Monitor Set, either directly or through radio repeater(s). The sensor uses the invisible frequency spectrum contiguous to the red end of the visible spectrum for detecting targets. The sensor processes the response and provides detection information. The information is incorporated within a digital message format and is transmitted to a distant Sensor Monitoring Set or Portable Monitor Set using the internal FM radio transmitter. It detects tracked vehicles, wheeled vehicles, and personnel; and provides information on which to base a count on objects moving through the zone.

2.3 CLASSIFICATION SENSORS

These sensors are designed to detect and classify single tracked vehicles, wheeled vehicles and groups of personnel. The number of activations provides information regarding activity.

2.3.1 Sensor, Anti-Intrusion DT-562 () GSQ is an expendable/recoverable hand emplaced seismic/acoustic battery powered classifying sensor. The sensor is self-contained and communicates either directly or through radio repeater(s) to the Sensor Monitoring Set and Portable Monitor Set. The sensor extracts specific features from incoming seismic and acoustical signals. The extracted information is encoded within the message format and transmitted to the distant Sensor Monitoring

Set directly or through a radio repeater(s) using the internal FM radio transmitter. The sensor will detect targets; classify tracked vehicles, wheeled vehicles, and personnel; and provide information on which to base vehicle count.

2.3.2 Sensor, Anti-Intrusion DT-567 ()/GSQ is an expendable/non-recoverable, battery operated, air emplaced seismic classifying sensor. The sensor is self-contained and communicates with the REMBASS monitoring sets either directly or through radio repeaters and is capable of being dispensed from a helicopter dispenser system, a Practice Multiple Bomb Rack (PMBR) mounted on either an OV-1 Army Aircraft or OV-10 Marine Corps Aircraft, and high performance aircraft dispenser systems. The sensor detects seismic disturbances to the earth imparted by moving personnel and vehicles. It then classifies the target and incorporates the information within the digital message format and transmits it directly or through a radio repeater(s) to a distant Sensor Monitoring Set or Portable Monitor Set using the internal FM radio transmitter. It classifies tracked vehicles, wheeled vehicles, and personnel.

2.3.3 Sensor, Anti-Intrusion DT-570 ()/GSQ is an expendable/non-recoverable, battery operated, artillery emplaced seismic classifying sensor. The sensor is self-contained and communicates with the REMBASS monitoring sets either directly or through radio repeater(s), and is emplaced using 155 mm artillery projectiles. The sensor detects seismic disturbances to the earth imparted by moving vehicles and personnel. It classifies the target and incorporates within the digital message format the information and transmits it to the distant Sensor Monitoring Set or Portable Monitor Set using the internal FM radio transmitter. It is capable of classifying tracked vehicles, wheeled vehicles, and personnel.

2.3.4 Sensor, Anti-Intrusion DT-573 ()/GSQ is an expendable/recoverable, hand emplaced, strain sensitive, battery operated, classifying cable sensor, that communicates directly or through radio repeater(s) to the Sensor Monitoring Set or Portable Monitor Set. The sensor uses a strain sensitive cable technique to detect and classify targets. The information is incorporated into the message format and is transmitted either directly or through up to three radio repeaters, to the Sensor Monitoring Set or Portable Monitoring Set using its internal FM radio transmitter.

2.3.5 Sensor Analog DT-563 ()/GSQ is an expendable/recoverable, hand emplaced, battery powered, analog acoustic listening sensor which is seismically triggered. The triggering action for the audio takes place when a seismic signal of a determined strength is exceeded. A delay (10 seconds) is included from the time of seismic detection to allow the intruder to move into acoustic range, reducing battery power requirements. When triggered, the sensor transmits a digital message including the sensor ID and the analog message identifier followed by 15 seconds of audio information. This information is transmitted through the analog/digital repeater(s) (RT 1175 ()/GSQ) to the Sensor Monitor Set.

2.3.6 Imaging Sensor. The Advanced Development (AD) model (REMBASS 2) of the Remote Imaging Confirming Sensor (RICS) is a non-commandable, self contained, portable, thermal imaging system. It operates in the 3-5 micron (infra-red) region of the spectrum. It is a compliment to the Basic REMBASS which is now entering Engineering Development (ED) phase of production. RICS is used to detect the presence of intruders, to

confirm the nature of the intrusion and to permit the operator to classify the type of intrusion. The AD model of the RICS does not include a REMBASS data transmission system (DTS) interface; however, it does employ an appropriately formatted digital output which assures that follow-on engineering development models can achieve REMBASS DTS compatibility in terms of bandwidth, channel assignments, modulation and baud rates.

III. RADIO REPEATER DESCRIPTION

3.1 GENERAL

The three radio repeater designs of Basic REM-BASS share common modules -- synthesizer, store and forward logic, and receiver. Certain functions have been added to the RT-1175 () GSQ which will allow it to pass analog as well as digital information. The repeaters receive information transmitted by sensors, other repeaters, or both, and re-transmits it to another repeater, Sensor Monitoring Set, or a Portable Monitor Set. Each of the three repeaters are discussed in detail below.

3.2 Repeater, Radio RT-1175 ()/GSQ is an expendable/recoverable hand emplaced digital/analog repeater. The repeater is capable of being operated by an internal battery source or by AC/DC. It is emplaced either on the ground or operated from an aircraft as a self-contained (internal battery) repeater. The RT-1175 uses modules identical to

the RT-1200 and the RT-1201 except that two program/synthesizer modules are used to allow simultaneous operation of the receiver and transmitter. A frequency duplexer is included to provide the receiver/transmitter isolation required to allow the device to operate as specified without requiring more than 11 MHz frequency separation. The repeater also has the capability of digital data (store and forward) transmission.

3.3 Repeater, Radio RT-1200 () GSQ is an expendable/non-recoverable, air dropped, ground implant digital single channel repeater. The repeater is self-contained using a module battery and programming arrangement. The repeater is designed to be launched from medium performance aircraft or helicopters. The repeater acts as a digital store and forward device, re-transmitting after each valid parity, a correct message, after the message has been received in its entirety. The unique modules that make up the RT 1200 are the store and Forward Logic Assembly, Programmer/Synthesizer Assembly, Diplexer Assembly, Receiver Assembly, and the Battery Assembly.

3.4 Repeater, Radio RT-1201 () GSQ is an expendable/non-recoverable air dropped digital single channel repeater. The repeater is self-contained, using a module stock battery and programming arrangement identical to the one used in the RT-1200 repeater. The aft section of the assembly is modified to include a 2 stage parachute deployment system. The repeater is designed to be launched from medium performance and rotary wing aircraft. The repeater acts as a digital store and forward device, re-transmitting after each valid parity, a correct message, after the message has been received in total.

IV. RECEIVING AND MONITORING EQUIPMENT

4.1 GENERAL

The Receiving and Monitoring Equipment listed below receive, decode and provide analog monitoring, temporary visual digital display and permanent hard copy print-outs of analog and digital sensor outputs. Each of the components are discussed below.

4.2 Antenna Group OE-239 ()/GSQ 187 consists of an omni-directional antenna, solid state wide band pre-amplifier and an antenna coupler. The antenna incorporates two dipole antennas in a collinear manner. All dipole elements operate over the required frequency range without retuning. The antenna and pre-amplifier can be positioned away from the antenna coupler a maximum of 200 feet. The antenna coupler's single RF input is divided into four isolated outputs providing the capability of connecting four Sensor

Monitoring Sets from one Antenna Group, OE-239. The addition of Commandability to the system will have no effect on the Antenna Group.

4.3 Sensor Monitoring Set AN/GSQ-187 () is a dual channel receiver only monitoring unit. The Sensor Monitoring Set (SMS) has the capability of monitoring two independent RF channels simultaneously. The SMS has the capability of decoding and displaying data in two forms; the (temporary) visual display, and the (permanent) hard copy printout. The SMS also provides the capability to monitor analog sensor information using a head set connected to the head set connector on the SMS control panel. The SMS is field operable with internal 12V DC Battery or by using an external AC/DC power source. A total of four SMS's may be connected simultaneously to one OE-239 Antenna Group, monitoring up to eight individual RF channels.

4.4 Portable Monitor Set R-2016 ()/GSQ is a portable, hand held single channel, battery operated receiver and display, which receives, decodes and displays sensor activation information. The Portable Monitoring Set provides a visual display of sensor individual Identification (ID) Code and associated classifications. It has the capability to simultaneously display any 10 of 64 possible sensor ID's.

V. COMMAND EVALUATION

5.1 GENERAL

Commandability will add a new dimension to the conventional methods of deployment and utilization of unattended ground sensor systems. It will provide the commander with increased scope of capability permitting the more effective use of REMBASS. For example, commandability can provide the commander with the following additional operational capabilities:

- Stay-behind or dormant sensor arrays.
- On-line (real time) or "batch processing" (i.e., near-real time) data collection and data batch processing through a sensor processing unit (SPU).
- The potential ability to remotely re-program the internal logic of a previously emplaced sensor to meet new threat situations.

- The ability to conserve rf spectrum, system battery life, etc., through the execution of diurnally-oriented on/off commands.
- Dynamic interaction with other service such as the Marine Corps Forward Pass concept.
- The ability to reduce emi/rfi by disabling "talkers."
- The potential to meet new (presently unspecified) requirements for REMBASS in such areas as: (1) rear area protection, (2) border control and surveillance, (3) direct support of other Army combat arms, and (4) enhanced target acquisition capabilities.

5.1.1 Objectives and Alternatives

The REMBASS Materiel Need (MN) specifies commandability as a requisite element of the Type I System. Revisions to the MN also identify two candidate sensors (DT-563 Seismic/Analog Confirming Sensor, and the RICS (Remote Imaging Confirming Sensor)) as specific items which will be capable of responding to remotely originated command messages.

In addition, expanded operational roles for the REMBASS family of ground sensors (e.g., stay-behind deployment, border protection, etc.) are, by inference, further expanding the requirement for system-level commandability to include virtually the full compliment of hand-emplaced detection and classifying sensors as well as the full compliment of repeaters (hand, ballistic, and hang-up). The focus of this TOA/TOD is not the analysis of whether or not to incorporate commandability, but rather to assess the following:

- Alternative means for accomplishing the REMBASS system's data transmission subsystem (DTS), supporting hardware and ancillary items to most effectively accomplish functional commandability.
- To identify those electronic commands which can be associated with the seismic/analog sensor DT-563.
- To identify those electronic and electro-mechanical commands which can be associated with the Remote Imaging Confirming Sensor (RICS).
- To identify those commands which will serve Type I REMBASS detection and/or classification sensors.
- To identify possible candidate command concepts which will serve Type II (Advanced Development) hardware and systems concepts.
- To advance candidate methodologies illustrating how commandability may be accomplished at or in various REMBASS equipment end items and how these approaches will integrate into the system as a whole.
- To identify how individual end items may require modification or alteration to achieve commandability.

5.2 COMMAND FUNCTIONS

This section outlines three broad areas in which command functions are now presently applicable. Appropriate tables in each subsection provide lists of potential commands, a brief explanation of the "meaning" of the command and some of the technical, tactical or operational concepts associated with the specific command function. The three areas covered include: (1) those commands associated with the DT-563 seismic/analog sensor, (2) the Remote Imaging Confirming Sensor including electronic and electro-mechanical commands, and (3) with all general detection and/or classification sensors presently incorporated into Type I REMBASS.

5.2.1 DT-563 Seismic/Analog Sensor

Table 5.2-1 provides a "menu" of possible commands to be used in conjunction with this sensor and assesses the operational, tactical and logistics associated therewith. Table 5.2-2 presents raw (unpublished) data relating to the ability of both "trained" and "untrained" personnel to distinguish (i.e., correctly classify) target vehicles as a function of time and percentage of correct classifications achieved.

5.2.2 Proposed DT-563 Analog Duty Cycle

Appendix E provides a technical memorandum dealing with assessment and recommendations relating to the analog duty cycle of this device, along with specific suggestions for enhancing the sensor's False Alarm Rate (FAR) through the use of VFP (variance frequency processor) type of internal logic associated with the sensor's seismic transducer.

5.2.3 Remote Imaging Confirming Sensor

There are two "sets" of commands which are associated with this device; the first "set" involves electronic-only commands; the second "set" involves electro-mechanical commands, i.e., those associated with "pan," "tilt," "zoom," etc. type of mechanisms and/or servo motors (Table 5-2-3). Initial assessment of the present AD RICS prototype design involves the following factors:

- a. Command functions are known to be required but are incorporated into the design on a "hard wire" basis only.

TABLE 5.2-1. ACOUSTIC COMMANDS

| | | |
|--|---|---|
| <ul style="list-style-type: none"> ● TOT* -Increment -Decrement | <ol style="list-style-type: none"> 1. Optimum operator detection performance for a variety of targets occurs at 10* seconds or less. 2. Possibility of extending useful life of sensor's battery by reducing on-air time to optimum. 3. Possibility of extending repeater useful life. 4. Possibility of using more analog sensors per discrete radio channel. <p>*Time Out Timer</p> | <ol style="list-style-type: none"> 1. Refer to Table 5-2-2 for preliminary results of target classification results based on various time increments. 2. Sensor's on-board EOM timer or local oscillator, or programmable synthesizer could provide source of time increments. 3. First activation will give operator positive indication as to how long TOT is set for and possibility exists that if more time is needed, he will call sensor and extend TOT before target moves out of range. |
| <ul style="list-style-type: none"> ● DIGITAL ONLY -No Analog | <ol style="list-style-type: none"> 1. Causes sensor to act as a seismic detector. 2. ACK = sensor's ID | <ol style="list-style-type: none"> 1. In this arrangement, no analog data will be sent. |
| <ul style="list-style-type: none"> ● REVERT NORMAL | <ol style="list-style-type: none"> 1. Restores DT-563 to analog mode. 2. ACK = sensor's ID plus analog burst | <ol style="list-style-type: none"> 1. TOT setting will be last command setting received. |
| <ul style="list-style-type: none"> ● SENSITIVITY | <ol style="list-style-type: none"> 1. Permits selection of possibly 1 of 3 sensitivity levels. | <ol style="list-style-type: none"> 1. Widely used in SEAOPS, however sensors were not optimally employed in all instances; ACUSID III air dropped and COM MIKE canopy hang-up. DT-563 may not require wide dynamic range of sensitivity, and AGC should handle wide variation in gain requirements. |

TABLE 5.2-1. ACOUSTIC COMMANDS (Cont'd)

| | | |
|--|--|---|
| <p>INC/DEC SENSITIVITY (or GAIN)</p> | <p>1. No quantitative data available to indicate: (a) how much dynamic range would be desirable, and (b) whether classification capability will be materially enhanced for UGS device.</p> | <p>1. Problems regarding sensor's on-board electronics to provide for increase/decrease in sensitivity, and the overall effectiveness of sensor's AGC needs to be worked-out with manufacturer and organizations such as USARIBSS.</p> <p>2. Acknowledgement may be required, or at minimum, sensor's ID as indication that message received at sensor.</p> |
|--|--|---|

TABLE 5.2-2. PERFORMANCE AS A FUNCTION OF TARGET AND TIMES

Operator performance in correctly classifying various targets as a function of listening time via a MINISID/AAU Analog Sensor System.

| CLASS PERSONNEL | INCREMENTS IN SECONDS | | | | | TARGET |
|-----------------|-----------------------|-----|-----|-----|-----|-----------|
| | 1 | 3 | 6 | 10 | 15 | |
| B/Tng | 13% | 13% | 29% | 26% | 36% | 1/4 ton |
| A/Tng | 21% | 24% | 38% | 47% | 46% | |
| B/Tng | 15% | 7% | 19% | 15% | 11% | 3/4 ton |
| A/Tng | 31% | 29% | 38% | 42% | 29% | |
| B/Tng | 29% | 32% | 38% | 44% | 43% | 2 1/2 ton |
| A/Tng | 33% | 42% | 29% | 46% | 53% | |
| B/Tng | 24% | 25% | 26% | 25% | 24% | 5 ton |
| A/Tng | 25% | 33% | 44% | 43% | 46% | |
| B/Tng | 14% | 25% | 25% | 32% | 39% | APC |
| A/Tng | 31% | 15% | 35% | 47% | 53% | |
| B/Tng | 25% | 38% | 47% | 46% | 51% | Tank |
| A/Tng | 29% | 50% | 53% | 61% | 64% | |
| B/Tng | 22% | 22% | 61% | 42% | 49% | HeLo |
| A/Tng | 24% | 47% | 68% | 61% | 58% | |

This table shows the relationship of operator classification against time for type vehicles listed. These results were obtained during DT/OT I testing. These results were considered in the analysis on types of commands for the sensor.

% = Correct Classification
 B/Tng - Before training
 A/Tng - After training

b. Command functions will be required utilizing the Type I REMBASS data transmission subsystem (DTS) to replace the test and lab-level "hard wire" mode of operation.

c. Electronic commands involve relatively low technical risk, some cost, and potential re-evaluation of the unit's power budget.

d. Electro-mechanical commands will involve somewhat more complex analysis in that they may require the addition of feedback loops to assist operator orientation, and that they will add additional cost, weight and consume additional power.

5.2.4 Command Potential For All Sensors

Table 5.2-4 provides a list of (possible) commands for use with conventional REMBASS Type I air, ballistically, or hand emplaced sensors and repeaters.

The construction of the "menu" recognized that in some instances command complexity would entail very extensive modifications to the sensor's internal electronics in order to make the device fully responsive to the command message. Possible complexity did not, however, inhibit the construction of the table.

TABLE 5.2-3(a). IMAGING SENSORS (ELECTRONIC COMMANDS)

| | | |
|---|--|---|
| <ul style="list-style-type: none"> ● STANDBY | <ol style="list-style-type: none"> 1. Power-up, cool-down. 2. Holds this mode for 10 seconds. 3. Is used in conjunction with TAKE PICTURE command. | <ol style="list-style-type: none"> 1. Acknowledgement with 29-bit message, (digital) with S&F message header. 2. Overrides local seismic and DIRID-type sensors used at camera head. |
| <ul style="list-style-type: none"> ● GO MANUAL | <ol style="list-style-type: none"> 1. Places sensor under operator's control. | <ol style="list-style-type: none"> 1. Can be combined with "STANDBY" function. 2. Acknowledges with 29-bit S&F message. 3. Overrides local seismic and DIRID-like triggers. |
| <ul style="list-style-type: none"> ● TAKE PIX | <ol style="list-style-type: none"> 1. Imaging sensor reacts by taking snapshot but does not yet transmit picture. | <ol style="list-style-type: none"> 1. Acknowledges picture taken with S&F msg. 2. Reverts to automatic mode within 1-minute unless re-commanded. |
| <ul style="list-style-type: none"> ● XMIT ALL | <ol style="list-style-type: none"> 1. Sensor responds by transmitting full 30 k/b (25.6") of data, gray scale 1-16. 2. Sensor does not erase data from local memory. | <ol style="list-style-type: none"> 1. Sensor stores picture data until: <ol style="list-style-type: none"> a. Ordered to re-send b. 60-seconds elapse c. Ordered to take next subsequent snapshot d. Restored to automatic-local control. |

TABLE 5.2-3(a). IMAGING SENSORS (ELECTRONIC COMMANDS) (Cont'd)

| | | |
|--|--|---|
| <ul style="list-style-type: none"> ● TRANSMIT 1-half 2nd-half | <ol style="list-style-type: none"> 1. Sensor responds by transmitting (a) first 15" of data (GS 16-9) and appropriate header (for short message) 2. Second half of message will require a new header, and will contain GS 8-1. 3. Because of message structure, and line addressing, interleaving of first and second half of message does not appear to present significant problem. | <ol style="list-style-type: none"> 1. Repeaters activated for 15-second real-time regeneration (as opposed to 30-second for XMIT ALL command). 2. Reduces on-air and battery power consumption. 3. Second half of image may not be necessary especially for a "hot" target in which operator can make positive classification. |
| <ul style="list-style-type: none"> ● REPEAT | <ol style="list-style-type: none"> 1. Causes last image (full, 1st half or 2nd half to be retransmitted. | <ol style="list-style-type: none"> 1. If not requested within 30-seconds memory at camera "dumps" and this becomes invalid command. |

TABLE 5.2-3(b). IMAGING SENSOR "MECHANICAL COMMANDS"

| | | |
|--|---|--|
| <ul style="list-style-type: none"> ● PAN -left -right -return to boresight | <ol style="list-style-type: none"> 1. Causes 15° (left/right) pan 2. Re-centers camera onto original setting. | <ol style="list-style-type: none"> 1. Feedback appears to be essential to orient operator as to boresight of camera. 2. Servo-motors, drive mechanisms, feedback serve to erode power budget and will complicate message data pertaining to boresight. |
| <ul style="list-style-type: none"> ● ZOOM -in -out | <ol style="list-style-type: none"> 1. To permit operator to (possibly) enhance image and/or resolution. | <ol style="list-style-type: none"> 1. On snapshot type of basis, and with no "hot" target against which to work, accurate positioning of zoom from remote position may cause more trouble than it is worth. |

TABLE 5.2-4. COMMANDS TO ACTIVATE/DEACTIVATE INDIVIDUAL OR GROUPS OF SENSORS

| | | |
|---|---|---|
| <ul style="list-style-type: none"> ● TURN ON -individual | <ol style="list-style-type: none"> 1. Resume normal mode of operation 2. Causes sensor to go from quiescent to active mode. 3. Acknowledgement (ACK) through answer back of sensor's ID. | <ol style="list-style-type: none"> 1. Unless code, key, or sophisticated DTS employed, this function can also be accomplished by the enemy using CCI (Captured, Compromised, Intercept) equipment/techniques. 2. Roll-calling of sensor strings, arrays, etc., could alert enemy, especially if sensor receivers employ a common or blocks of common channels. 3. Sudden spate of sensor activity might tend to alert enemy. |
| <ul style="list-style-type: none"> ● TURN ON -group | <ol style="list-style-type: none"> 1. Would permit operator to activate an entire block, or groups of sensors with one radio transmission. 2. Single burst less likely to be intercepted than roll-calling. | <ol style="list-style-type: none"> 1. This and (individual) TURN ON are subject to coopting by enemy. 2. Sudden spate of activity could alert the enemy. 3. Programming-in a second (i.e., "all," "block" or "group" call and providing second decoder requires specific engineering cost and technical analysis, however, it is quite simple to build into Type II REMBASS. |

TABLE 5.2-4. (Cont'd). COMMANDS TO ACTIVATE/DEACTIVATE INDIVIDUAL OR GROUPS OF SENSORS

| | | |
|--|---|--|
| <ul style="list-style-type: none"> ● TURN OFF | <p>1. Causes the sensor to go dormant regarding activations, receiver still remains on.</p> | <p>1. Much the same comments apply to TURN OFF commands as do to TURN ON commands. The system can be spoofed, or coopted quite easily unless reasonably sophisticated schemes are employed so that just the capture of a sensor command transmitter will not enhance enemy's capabilities.</p> |
| <ul style="list-style-type: none"> ● DISABLE | <p>1. Causes sensor's squib to activate, and semi-permanently disable sensor. 2. Destruct codes, programmable code plugs, etc., may require security classification and handling.</p> | <p>1. Since sensor will disable under anti-tamper/anti-motion (SES and ADS accepted), and will disable at EOM, or EOL (whichever comes first), this feature, unless provided with safeguards, is potentially dangerous with little military utility to enhance it.</p> |
| <ul style="list-style-type: none"> ● CHANGE FREQUENCY (Xmit or Rcv) | <p>1. Causes sensor transmitter or receiver to go to a previously selected channel. 2. Permits operator to call-up a discrete channel to which he wants sensor transmitter/receiver to retune to.</p> | <p>1. Technical feasibility thru use of same I/O logic arrangement as is currently for Ili G programmer/synthesizer controls via the EPD (External Programming Device)</p> |

TABLE 5.2-4 (Cont'd). COMMANDS TO ACTIVATE/DEACTIVATE INDIVIDUAL OR GROUPS OF SENSORS

| | | |
|--|---|--|
| <ul style="list-style-type: none"> ● DELETE CLASSIFICATION CLASS (Delete P,W,D,T) | <p>1. Permits operator to restrict sensor output to a given or specific type or set of target classes.</p> | <p>1. This feature is a part of the SMS Design Specification. It could materially reduce the number of sensor messages outputted into the DTS system.</p> |
| <ul style="list-style-type: none"> ● SEND TEST MESSAGE | <p>1. Permits operator to verify that sensor is operable and that so much of the DTS as is required for that message is also operable.</p> <p>2. Interface does not appear to offer significant technical problems.</p> <p>3. Could also serve as the response (ACK) that the sensor has received and performed previously issued commands.</p> | <p>1. This could supplement a note or scratch pad on which the operator has recorded EOM/EOL data, and permit him to verify that the sensor addressed is (non) operable.</p> |
| <ul style="list-style-type: none"> ● CHANGE ID | <p>1. Used in conjunction with CHANGE FREQUENCY commands, and permits operator to assign a new ID to sensor if duplicate is in use.</p> | <p>1. Change of ID, etc., uses same I/O logic as is to be employed with the EPD and those sensors and repeaters which are thus accessed.</p> |
| <ul style="list-style-type: none"> ● NON REAL TIME/ REAL TIME | <p>1. In NRT, sensor could:</p> <ol style="list-style-type: none"> a. Count only b. Count & Classify c. Time Tag (+ a or b) <p>2. In RT, sensor performs normally.</p> | <p>1. Requires additional on-board logic, however, time-tagging, in relative time would be able to employ life clock.</p> |

TABLE 5.2-4 (Cont'd). COMMANDS TO ACTIVATE/DEACTIVATE INDIVIDUAL OR GROUPS OF SENSORS

| | | |
|---------------------------------|--|---|
| <p>● CHANGE REPORTING CYCLE</p> | <p>1. Present inhibit of 8-10 seconds permits passage of multiple high speed targets during period when sensor is inhibited. Under operator's command, inhibit times of from 1-10 seconds would be available to permit accurate counting.</p> | <p>1. Of potential value in non-classifying modes of operation when simple threshold logic would establish presence of target. Possibly would alter thinking of proposed design of the SSC/WBC (DT-573) which has no "Detect" message output.</p> |
| <p>● ENTER NEW PROGRAM</p> | <p>1. On board sensor microprocessor could be made amenable to: a. new instructions b. new programs c. new algorithms 2. Entering such instructions through SMS has been conjectured, and same I/O could be associated with command link, sensor receiver and decoder.</p> | <p>1. Local seismic/acoustic environment may warrant the sensor being reprogrammed to improve performance. 2. Threat of new target class vehicles (missile transporters, etc.) would also be possible cause of entering new microprocessor instructions.</p> |

5.3 MEASURES OF EFFECTIVENESS

Two sets of tables are provided in which a subjective ranking of the desirability of certain command features was made based on current Type I sensors specifically. The areas thus explored included the DT-563 Seismic/Analog device as a unique, specific entity and all other classifiers and detectors as another entity.

The "utility value" of the commands employed were rated over the following scale:

- Highly Desirable = 4
- Of Medium Desirability = 3
- Low Level of Desirability = 2
- Very Low Level of Utility = 1
- No Utility Foreseen = 0

Negative values were not employed.

5.3.1 DT-563 Sensor Measure of Effectiveness

Table 5.3-1 presents a ranking of the desirability or effectiveness foreseen for use with a series of commands associated with the DT-563 Seismic/Analog sensor specifically.

Because of the long on-air time (15 seconds), and a potentially high duty cycle^① of this device, the following commands attained the highest rank in order of preference:

- ON/OFF
- DIGITAL ONLY (Analog suppressed)
- VARIABLE TIME-OUT-TIMER (2-15 second bursts).

^① See Annex E.

TABLE 5.3-1. COMMAND FUNCTION VS. OPERATIONAL EFFECTIVENESS (DT-563)

| OPERATIONAL EFFECTIVENESS | COMMAND FUNCTION | | TURN ON/OFF | DISABLE | TEST/ACK | > TOT | DT563 DIGITAL ONLY | REVERT TO NORMAL | SEISMIC GAIN INC/DEC | CHANGE FREQ (X) (T) | CHANGE ID | NRT | CHANGE INHIBIT |
|-------------------------------|------------------|-----|-------------|---------|----------|-------|--------------------|------------------|----------------------|---------------------|-----------|-----|----------------|
| | High | Med | | | | | | | | | | | |
| EXTEND SYSTEM LIFE | 4 | 1 | 1 | 1 | 3 | 4 | 1 | 1 | 1 | 0 | 2 | 2 | 2 |
| PRE EMPLACEMENT ENHANCED | 3 | 0 | 3 | 3 | 3 | 3 | 2 | 3 | 2 | 1 | 2 | 2 | 2 |
| SELECTIVE MONITORING | 3 | 0 | 2 | 2 | 3 | 3 | 1 | 1 | 2 | 1 | 2 | 1 | 1 |
| RFI/EMI REDUCTION | 4 | 3 | 2 | 4 | 3 | 3 | 1 | 3 | 2 | 0 | 3 | 2 | 2 |
| OPERATIONAL STATUS CHECK | 2 | 0 | 4 | 1 | 2 | 2 | 2 | 1 | 1 | 0 | 1 | 1 | 1 |
| SITE, TERRAIN, MET VARIATIONS | 3 | 1 | 2 | 2 | 3 | 3 | 3 | 4 | 2 | 1 | 2 | 2 | 2 |
| ECM VULNERABILITY REDUCTION | 3 | 2 | 0 | 4 | 3 | 3 | 2 | 2 | 2 | 1 | 3 | 1 | 1 |
| MEET NEW TARGET THREAT | 3 | 1 | 1 | 4 | 3 | 3 | 3 | 3 | 2 | 2 | 3 | 2 | 2 |
| TOTALS | 25 | 8 | 15 | 23 | 24 | 15 | 18 | 14 | 6 | 18 | 13 | 13 | 13 |

Ranked

1 8 5 3 2 5 4 6 9 4 7

High = 4 Trivial = 1
 Med = 3 No Impact = 0
 Low = 2

5.3.2 Other Type I Sensors

Table 5.3-2 rates of Type I REMBASS sensors against device or system performance which is forecast for the REMBASS system deployed in a typical array of sensors and/or repeaters. The base line involved the current RBS-series of procurement specifications, and understanding of the contractor's approach via the PDR and FDR reviews.

The ranking, in order of preference, of the three most desirable commands were as follows:

- ON/OFF
- CHANGE (10") INHIBIT TIME
- COMMAND ACKNOWLEDGEMENT (or VERIFY INTEGRITY)

5.4 ADVANCED REMBASS COMMANDABILITY

There are two features applicable to commandability and state-of-the-art manufacturing technology which possibly could impact on Advanced Development commandability. These are:

- Reprogrammable internal sensor microprocessor algorithms and operating routines.
- Non-real time, or time-tagging and storage of data pending command.

5.4.1 Reprogrammable Microprocessors

A desire to remotely reprogram a sensor's micro-processor logic, algorithm or operating routines could prove advantageous in conflict situations which involve; (1) a new target threat, (2) MOBA or concentrated operations in built-up

TABLE 5-3.2. COMMAND FUNCTION VS. OPERATIONAL EFFECTIVENESS (CLASSIFIERS)

| OPERATIONAL EFFECTIVENESS | COMMAND FUNCTION | | | | | | | | | | |
|-------------------------------|------------------|---------|----------|------------------|----------------------|-------------|---------------------|-----------|-----|----------------|--|
| | TURN ON/OFF | DISABLE | TEST/ACK | REVERT TO NORMAL | SEISMIC GAIN INC/DEC | DELETE PMDT | CHANGE FREQ (X) (T) | CHANGE ID | MRT | CHANGE INHIBIT | |
| EXTEND SYSTEM LIFE | 4 | 1 | 0 | 1 | 1 | 1 | 1 | 0 | 0 | 2 | |
| PRE EMPLACEMENT ENHANCED | 3 | 0 | 3 | 3 | 3 | 2 | 2 | 2 | 0 | 2 | |
| SELECTIVE MONITORING | 3 | 0 | 3 | 1 | 2 | 3 | 1 | 1 | 0 | 2 | |
| RFI REDUCTION | 3 | 3 | 0 | 1 | 1 | 1 | 2 | 0 | 0 | 2 | |
| OPERATIONAL STATUS CHECK | 2 | 0 | 4 | 2 | 1 | 1 | 1 | 0 | 0 | 1 | |
| SITE, TERRAIN, MET VARIATIONS | 1 | 1 | 2 | 2 | 3 | 1 | 1 | 0 | 0 | 2 | |
| ECM VULNERABILITY REDUCTION | 2 | 1 | 1 | 0 | 0 | 1 | 2 | 2 | 0 | 2 | |
| MEET NEW TARGET | 2 | 1 | 1 | 2 | 2 | 2 | 1 | 1 | 0 | 3 | |
| EVALUATION TOTAL | 29 | 6 | 14 | 12 | 13 | 12 | 11 | 6 | 0 | 16 | |
| | Rank | 1 | 8 | 4 | 5 | 5 | 6 | 7 | 9 | 3 | |

* Higher Evaluation Total = More Attractive Command.
 High = 4 Very low = 1
 Med = 3 None = 0
 Low = 2

areas, and (3) the capability of expanding a sensor's inherent capability enabling it to meet specific requirements of other services or combat arms. Using the common module approach developed in SEAOPSS Phase III hardware and carried onward in Type I REMBASS "building block" approaches, it is not inconceivable that the basic shell of the sensor(s) would also serve FAALS missions, RAWs missions and the like.

5.4.1.1 Potential Applications. Conceptually, high-intensity combat situations in industrialized or well developed urbanized areas could, for example, derive benefit from a sensor which could be emplaced to meet (to name but two) situations which exist in this combat environment.

The first involves RAP (rear area protection) in which the sensor would typically be required to perform in areas of high cultural noise -- but noise which has repetitive and distinct signatures so that these could be programmed out of the sensor thus lowering the nuisance/false alarm rate associated with the environments around air fields, ports, rail yards, etc., with their known high ambient levels.

A second potential application involves the use of sensors in direct support of combat operations inside of cities, large industrial areas (albeit defunct) where reprogramming could, for example, permit a basic-building-block FAALS type of sensor to report on one specific type of muzzle blast, ignoring all others. Or, remotely "training" the sensor to work in a high ambient noise environment complete with multipath propagation so that it could be adapted to meet the local terrain and noise, or trained to identify new targets for which no data base signature file exists.

5.4.2 Stay Behind and Dormant Sensors

The fluid conflict situation can require a need for stay behind sensors; ones which will continue to function and time-tag data but which will only transmit upon receipt of valid execution commands to and from (for example) an RPV or other suitable platform.

Such dormancy could be accomplished by a simple command, or by a combination of command and emplacement settings. For example, the sensor's rf output power could be reduced from a nominal 2 watts to 250-milliwatts thus conserving battery power and reducing the chances for intercept or capture by the enemy. In the very low power mode, the sensor would broadcast to and receive commands from a "mother board" device which would provide the reference clock and the bulk storage required.

The "mother/daughter" arrangement can respond to a variety of commands with the "mother" serving as an intermediate storage repeater (either single channel, or multi-channel to serve RICS, RAWs, etc.), or perhaps tying both REMBASS sensors and smart mines together in a weapons-system arrangement.

NOT
Preceding Page BLANK - FILMED

VI. ALTERNATIVES

6.1 GENERAL DESCRIPTION

In analyzing the optimum method for adding a command capability to REMBASS six alternatives are presented.

- Alternative 1. Commandability will be accomplished employing unmodified repeaters to permit the REMBASS DTS to function in a bi-directional mode. This arrangement is illustrated in Figure 6-1(a) and 6-1(b).

- Alternative 2. Commandability is accomplished using dual, independent, stand-alone repeaters to achieve bi-directional communications. One set of repeaters supports sensor messages; the second set supports command messages. System diagrams for this alternative are shown in Figure 6-2(a) and 6-2(b).

- Alternative 3. Commandability is accomplished using dual repeaters mounted in a single package and on a single mounting chassis. Common antenna elements are used. SIRS (Sensor Inband Relay System) and Interference Control

System (ICS) circuitry is required to permit optimum technical performance to be achieved. System arrangements of this alternative are provided in Figures 6-3(a), 6-3(b), 6-3(c) and 6-3(d).

- Alternative 4. Commandability is accomplished by employing a two-channel pre-programmed repeater radio transmitter; one which switches momentarily to the pre-set "command frequency" upon recognition of the second data field binary code within the BISS/REMBASS message. It reverts to the (normal) rf channel upon completion of the command function. In this Alternative, two receivers are used; one for command frequencies, the other for sensor frequencies. The system arrangement covered by this alternative is shown in 5-4(a) and 5-4(b).

- Alternative 5. Commandability is accomplished by employing a two-channel, pre-programmed repeater radio transmitter and a single receiver whose operating frequency is common to both the sensor data link and the command data link. This arrangement is illustrated in Figure 5-5(a) and 5-5(b).

- Alternative 6. Commandability is accomplished by achieving direct line of sight (LOS) rf links to the sensors. Repeaters are not employed. Various methodologies may be employed to attain LOS rf paths. These could include: (a) fixed and/or rotary wing aircraft, (b) remotely piloted vehicles (RPV), (c) balloon supported transmitter/antenna, and (d) other mechanical means for achieving required antenna height and gains.

6.2 ALTERNATIVE COMMON CHANGES

The common changes/features required by each of these alternatives consist of the following:

- All sensors require the addition of receivers, frequency determining elements, demodulators and decoders, modifications to existing sensor internal logic to effectuate commands, and T/R (transmit/receive) antenna relay functions.

- All command data transmission subsystems (C/DTS) functions are on an "in band" basis. Unlike SEAOPSS, no "out-of-band" command data links are employed.

- The RICS sensor will require both electronic and electromechanical command functions.

- The formats, content, and data fields defined in the BISS/REMBASS interoperability agreement will be adhered to as will agreements concerning antenna polarization, band rates, etc.

- A command transmitter is required.

6.3 OPERATIONAL DESCRIPTION OF ALTERNATIVES

6.3.1 Alternative 1

System diagrams for this alternative are shown in both a single repeater configuration (Figure 6-1A) and a three repeater configuration (Figure 6-1B). The following operational description focuses on the three repeater system, however, the single repeater configuration is operationally the same from RR-3 back to the SMS.

ALTERNATIVE 1

- R----- RECEIVER
- D----- DECODER
- A----- ANTENNA OR DIPLEXER
- M----- MODIFICATION OF ELECTRONICS/CHASSIS
- > COMMAND LINK
- > SENSOR DATA LINK

1. SENSOR: ADD A RECEIVER, DECODER, ANTENNA OR DIPLEXER, ADDITIONAL UNIQUE ELECTRONICS, AND MODIFY THE BASIC SENSOR CHASSIS.
2. RADIO REPEATER: REPEATER REMAINS ESSENTIALLY THE SAME.
3. SENSOR MONITORING SET: NO CHANGES REQUIRED.
4. COMMAND TRANSMITTER: DEVELOP A COMMAND TRANSMITTER TO INCLUDE A TRANSMITTER, ENCODER, AND ASSOCIATED UNIQUE ELECTRONICS

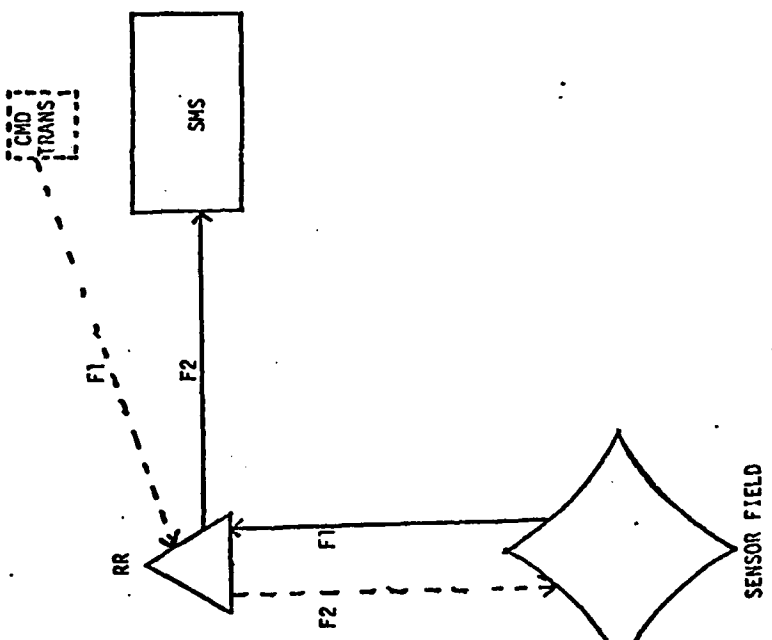

FIGURE 6-1A

ALTERNATIVE 1

- R--- RECEIVER
- D--- DECODER
- A--- ANTENNA OR DIPLEXER
- M--- MODIFICATION OF ELECTRONICS/CHASSIS
- > COMMAND LINK
- > SENSOR DATA LINK

• SENSOR: ADD A RECEIVER, DECODER ANTENNA OR DIPLEXER, AND ADD ADDITIONAL UNIQUE ELECTRONICS, AS WELL AS MODIFICATION OF BASIC SENSOR CHASSIS.

• RADIO REPEATER: RELAY REMAINS ESSENTIALLY THE SAME.

• SENSOR MONITORING SET: NO CHANGES REQUIRED.

• COMMAND TRANSMITTER: DEVELOP A COMMAND TRANSMITTER TO INCLUDE A TRANSMITTER, ENCODER, AND ASSOCIATED UNIQUE ELECTRONICS.

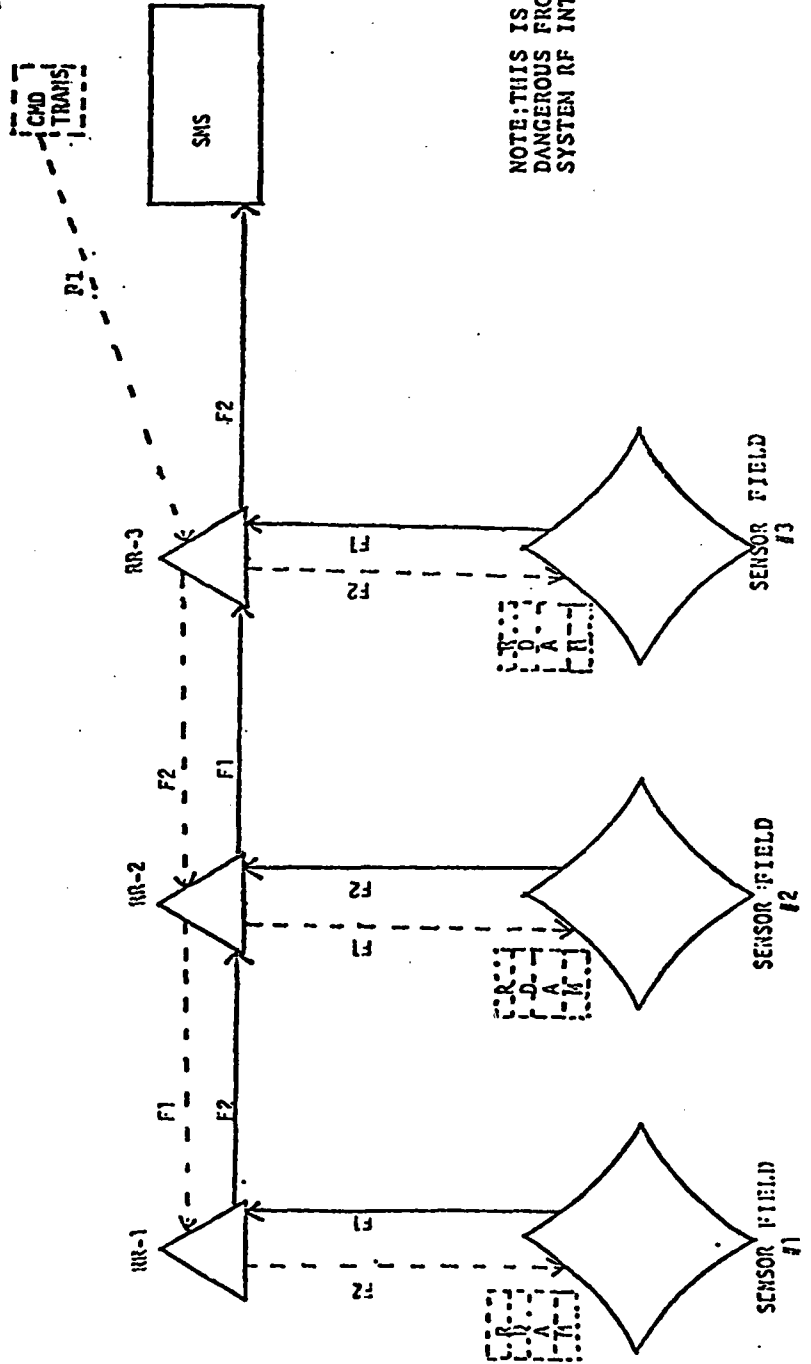

NOTE: THIS IS POTENTIALLY VERY DANGEROUS FROM THE POINT OF SYSTEM RF INTERFERENCE.

FIGURE 6-1B

The basic 3 repeater system diagram shows both the data flow for the sensor data link and the command link, as well as a possible frequency allocation plan. Following a typical data flow pattern, Sensor Field #1 transmits data to RR-1 on frequency F1. RR-1 retransmits data to RR-2 on F2 (Sensor Field #2 also transmits to RR-2 on F2). RR-2 retransmits data to RR-3 on F1 (Sensor Field #3 also transmits to RR-3 on F1). RR-3 transmits to the SMS on F2. The command data is transmitted from the Command Transmitter to RR-3 of F1. RR-3 retransmits the command data to RR-2 and Sensor Field #3 on F2. RR-2 retransmits the command data to RR-2 and Sensor Field #2 on F1. RR-1 retransmits the command data to Sensor Field #1 on F2.

6.3.2 Alternative 2

System diagrams for this alternative are shown in a single repeater configuration (Figure 6-2A) and in a three repeater configuration (Figure 6-2B). For the purpose of discussion only the three repeater system will be discussed in detail, however, the single repeater configuration will be operationally the same from RR-3 back to the SMS.

The three repeater system diagram shows both the data flow for the sensor data and command link, utilizing 6 repeaters, as well as a possible frequency assignment plan. The sensor data is transmitted from Sensor Field #1 to RR-1(1) on frequency F1. RR-1(1) retransmits data to RR-2(1) on F2 (Sensor Field #2 also transmits to RR-2(1) on F2). RR-2(1) retransmits data to RR-3(1) on F3 (Sensor Field #3 also transmits to RR-3(1) on F3). RR-3(1) retransmits data to the SMS on F4. The command data is transmitted to RR-3(2) on F8. RR-3(2) retransmits data to RR-2(2) and Sensor Field #3

ALTERNATIVE 2

- R-... RECEIVER
- D-... DECODER
- A-... ANTENNA/DIPLXER
- N-... MODIFICATION OF ELECTRONICS/CHASSIS
- > COMMAND LINK
- SENSOR DATA LINK

2. SENSOR: ADD A RECEIVER, DECODER, ANTENNA OR DIPLXER, ADDITIONAL UNIQUE ELECTRONICS, AND MODIFY BASIC SENSOR CHASSIS

3. RADIO REPEATER: EMPLOY TWO RADIO REPEATERS AT EACH SITE. (ONE FOR COMMAND & ONE FOR SENSOR DATA)

4. SENSOR MONITOR SET: REQUIRES NO MODIFICATIONS.

5. COMMAND TRANSMITTER: DEVELOP A COMMAND TRANSMITTER WHICH INCLUDES: A TRANSMITTER ANTENNA, ENCODER, ANTENNA, AND ASSOCIATED ELECTRONICS.

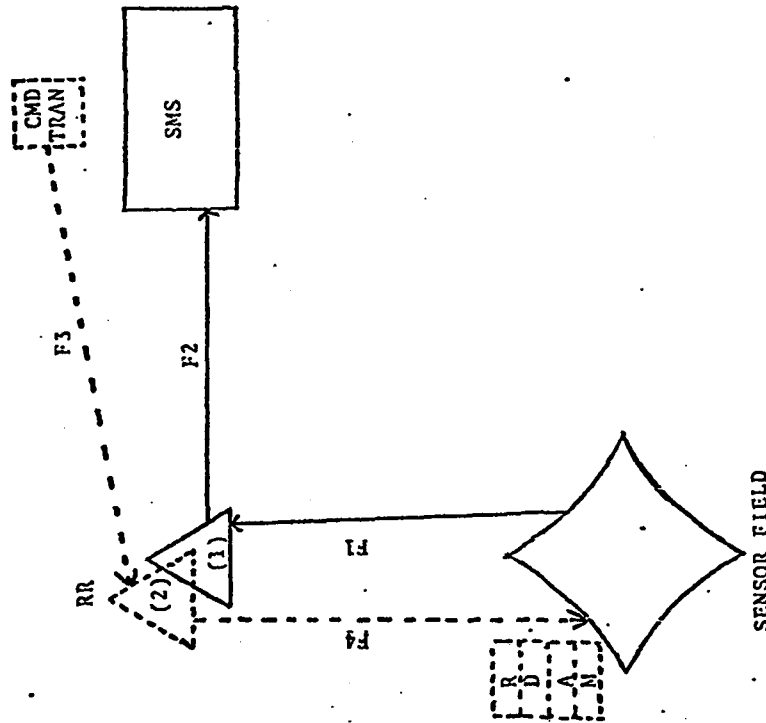
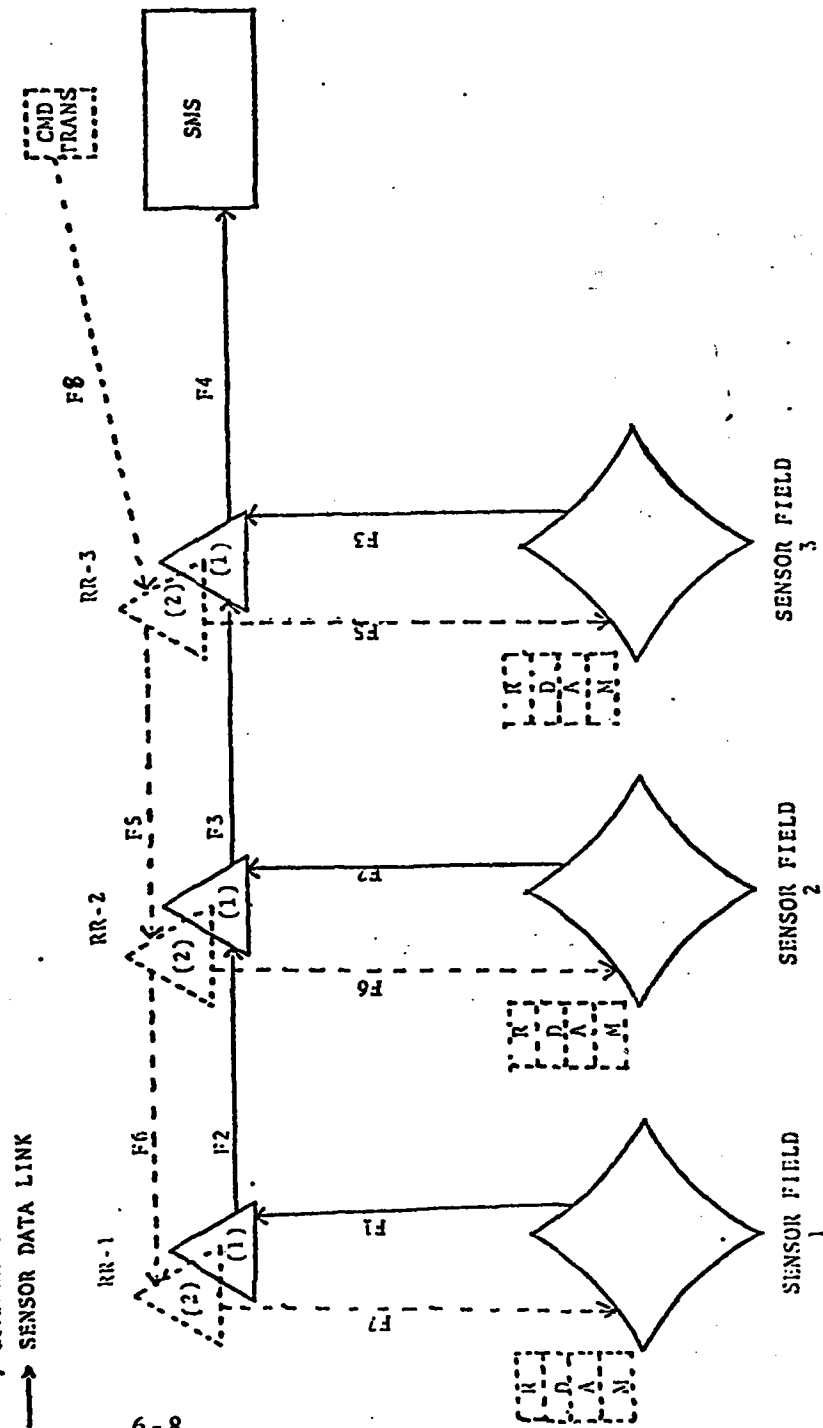

FIGURE 6-2A

ALTERNATIVE 2

- R..... RECEIVER
- D..... DECODER
- A..... ANTENNA OR DIPLXER
- N..... MODIFICATION OF ELECTRONICS/CHASSIS
--> COMMAND LINK
- > SENSOR DATA LINK



0-8

④. SENSOR: ADD A RECEIVER, DECODER, ANTENNA OR DIPLXER, ADDITIONAL UNIQUE ELECTRONICS, AND MODIFY BASIC SENSOR CHASSIS.

⑤. RADIO REPEATER: EMLACE TWO RADIO REPEATERS AT EACH SITE. (ONE FOR COMM- AND ONE FOR SENSOR DATA) OPERATION OF EACH INDIVIDUAL REPEATER

⑥. SENSOR MONITORING SET: REQUIRES NO MODIFICATION

⑦. COMMAND TRANSMITTER: DEVELOP A COMMAND TRANSMITTER WHICH INCLUDES: A TRANSMITTER, ENCODER, ANTENNA, AND ASSOCIATED ELECTRONICS.

FIGURE 6-2B

1

on F5. RR-2(2) retransmits data to RR-1(2) and Sensor Field #2 on F6. RR-1(2) transmits data to Sensor Field #1 on F7. The frequencies utilized in Alternative 2 illustrate how spatial ring around could be prevented in the system. The allocation of each leg shows frequency planning flexibility, and a typical number of frequencies required in a system.

6.3.3 Alternative 3

System diagrams for this alternative are shown in both a single repeater configuration (Figure 6-3A) and a three repeater configuration (Figure 6-3B). The following operational description focuses on the three repeater system, however, the single repeater configuration is operationally the same from RR-3 back to the SMS.

The three repeater system diagram shows both the data flow for the sensor data link and the command link, as well as a possible frequency assignment plan. Sensor information is transmitted from Sensor Field #1 to RR-1 on frequency F8. RR-1 retransmits data to RR-2 on F2 (Sensor Field #2 also transmits to RR-2 on F-2). RR-2 retransmits data to RR-3 on F3 (Sensor Field #3 also transmits to RR-3 on F3). RR-3 retransmits data to SMS on F4. The command data is transmitted to RR-3 on F1. RR-3 retransmits command to RR-2 and Sensor Field #3 on F5. RR-2 retransmits command to RR-1 and Sensor Field #2 on F6. RR-1 retransmits command to Sensor Field #1 on F7. As in Alternative 2, frequencies are utilized to illustrate a possible frequency assignment scheme. The Sensor Inbank Relay System (SIRS) and Interference Control System (ICS) circuitry required to permit optimum technical performance of the system is depicted in Figures 6-3C and 6-3D.

ALTERNATIVE 3

- R----- RECEIVER
- D----- DECODER
- A----- ANTENNA OR DIPLEXER
- .-.-.-.-> COMMAND LINK
- > SENSOR DATA LINK

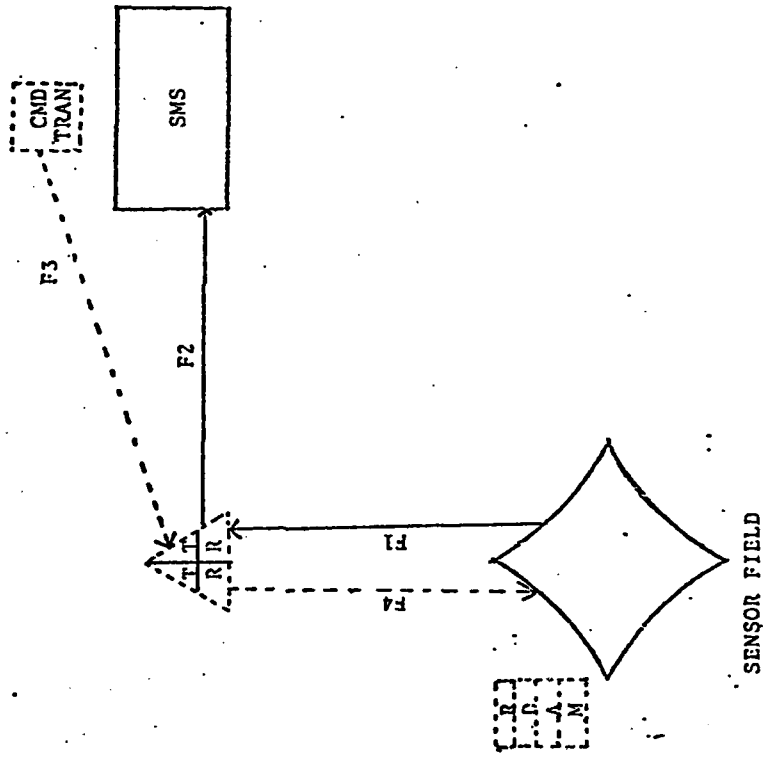

0. SENSOR: ADD A RECEIVER, DECODER, ANTENNA OR DIPLEXER, ADD ADDITIONAL UNIQUE ELECTRONICS, AND MODIFY THE BASIC SENSOR CHASSIS.

0. RADIO REPEATER: DEVELOP A 2 CHANNEL RADIO REPEATER WITH 2 TRANSMITTERS, 2 RECEIVERS, UTILIZING SHARED ENCODERS, DECODERS, SGF MODULES TO THE MAXIMUM EXTENT.

0. SENSOR MONITORING SET:
NO CHANGES REQUIRED

0. COMMAND TRANSMITTER:
DEVELOP A COMMAND TRANSMITTER WHICH INCLUDES: A TRANSMITTER, ENCODER, AND ANTENNA AS WELL AS ASSOCIATED UNIQUE ELECTRONICS.

FIGURE 6-3A

ALTERNATIVE 3

0. SENSOR: ADD A RECEIVER
 DECODER, ANTENNA OR
 DIPLEXER, AND ADD
 ADDITIONAL UNIQUE
 ELECTRONICS, AS WELL
 AS MODIFICATION OF
 BASIC SENSOR CHASSIS

0. RADIO REPEATER:
 DEVELOP A 2 CHANNEL
 RADIO REPEATER WITH
 2 TRANSMITTERS, 2
 RECEIVERS. SOME SHAR-
 ING OF ELECTRONICS
 SUCH AS ENCODERS,
 DECODERS, SEE, AND
 ANTENNA WOULD BE
 REQUIRED.

0. SENSOR MONITOR SET:
 NO CHANGES REQUIRED.

0. COMMAND TRANSMITTER:
 DEVELOP A COMMAND
 TRANSMITTER WHICH
 INCLUDES: A TRANS-
 MITTER, ENCODER, AND
 ANTENNA AS WELL AS
 ASSOCIATED UNIQUE
 ELECTRONICS.

- R----- RECEIVER
- D----- DECODER
- A----- ANTENNA OR DIPLEXER
- F----- MODIFICATION OF ELECTRONICS
- C----- COMMAND LINK
- S----- SENSOR DATA LINK

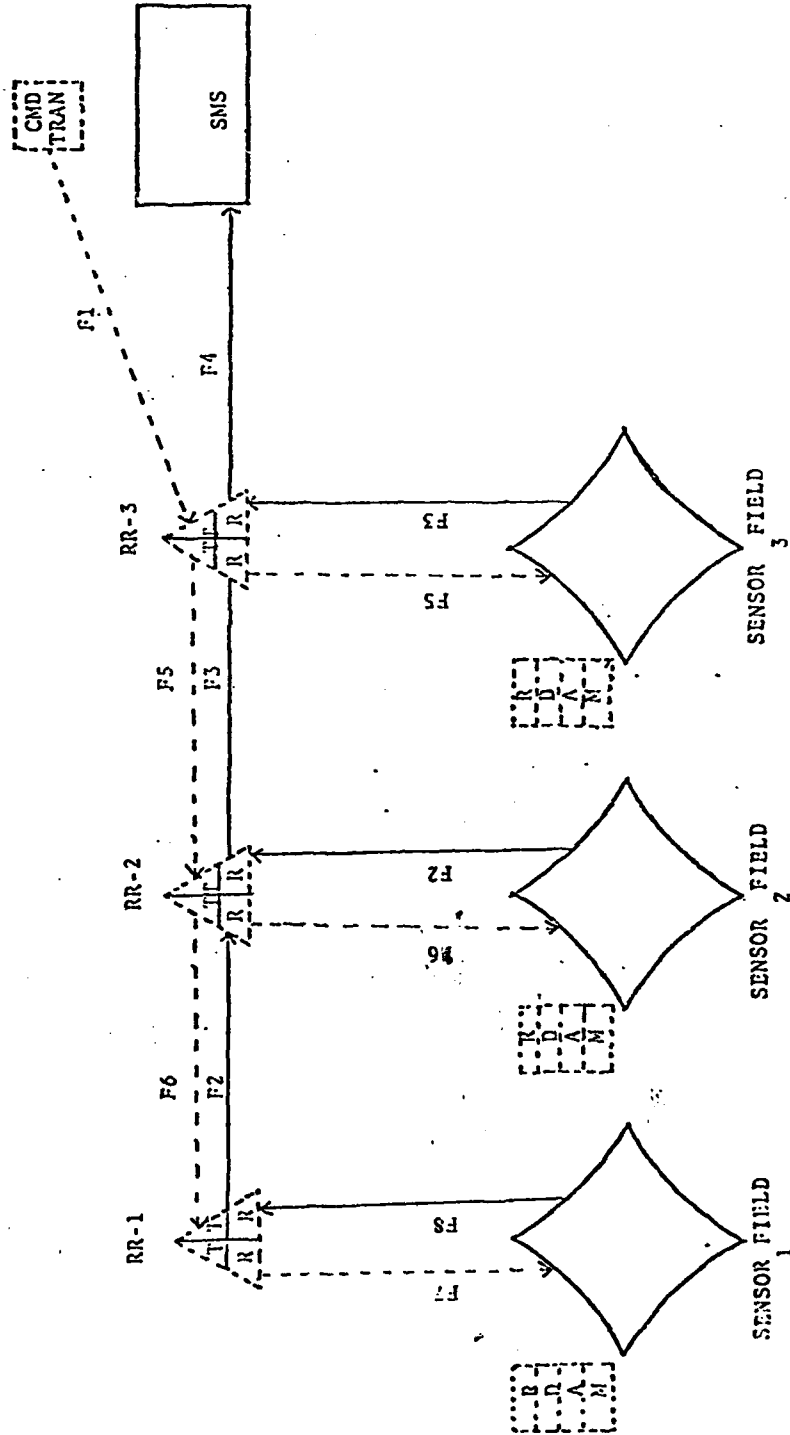

6-11

FIGURE 6-3B

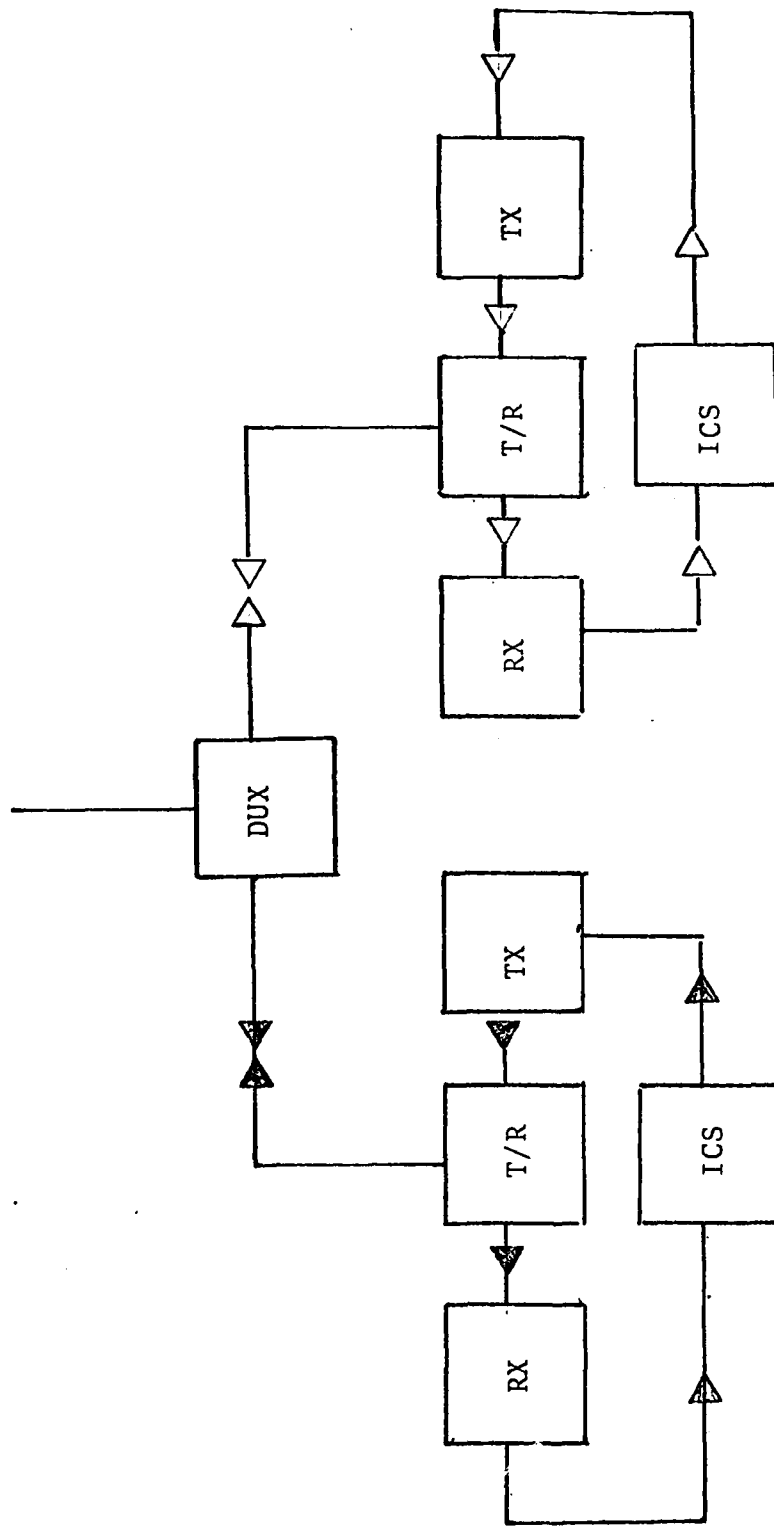

FIGURE 6-3 (c) Conceptual arrangement of a Sensor Inband Relay System (SIRS) employing dual, independent repeater elements on a single chassis, and employing Interference Control Systems (ICS) to permit closer channel separations to be employed.

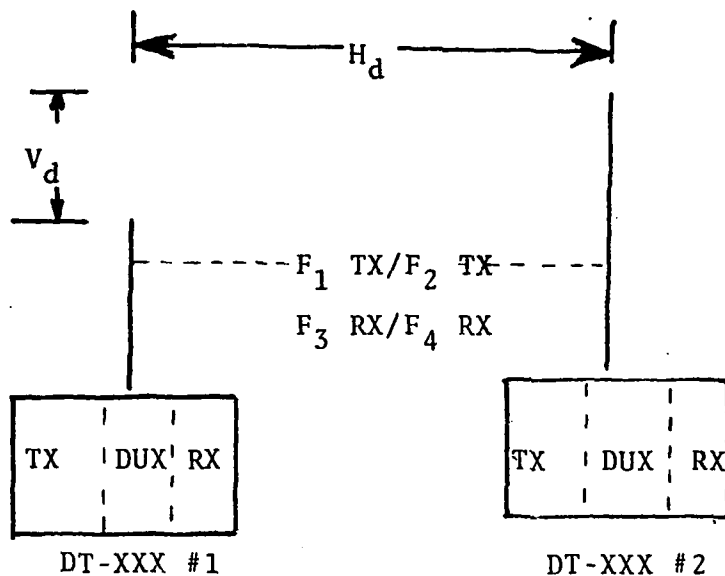

Figure 6-3 (d) In employing two repeaters, horizontal and vertical antenna separation (H_d & V_d) as well as transmit and receive frequency separations are important to prevent intermodulation products (IMP), desensitization, and spurious interference.

6.3.4 Alternative 4

System diagrams for this alternative are shown in Figures 6-4A and 6-4B. The single repeater system (Figure 6-4A) is a simplified diagram of the system while the three repeater system (Figure 6-4B) is more complex and will be discussed fully from an operational aspect.

The three repeater system diagram shows both the data flow for the sensor data link, and the command link, as well as a typical frequency assignment. Sensor information is transmitted from Sensor Field #1 to RR-1 on frequency F1. RR-1 retransmits data to RR-2 on F2 (Sensor Field #2 also transmits to RR-2 on F2). RR-2 retransmits data to RR-3 on F3. (Sensor Field #3 also transmits to RR-3 on F3). RR-3 retransmits data to the SMS on F4. The command data is transmitted to RR-3 on frequency F8. Through special message coding the transmitter selects F5 (transmitter has capability of transmitting on two separate frequencies) and transmits to RR-2 on F5. RR-3 also transmits to Sensor Field #3 on F5. The same process is used with RR-2 transmitting to RR-1 on F6. RR-2 also transmits to Sensor Field #2 on F6. RR-1 through the same selection process transmits to Sensor Field #1 on F7.

6.3.5 Alternative 5

System diagrams for this alternative are shown in a single repeater configuration (Figure 6-5A) and a more complex three repeater configuration (Figure 6-5B) which will be discussed fully from an operational aspect.

ALTERNATIVE 4

- R----- RECEIVER
- D----- DECODER
- A----- ANTENNA OR DIPLEXER
- N----- MODIFICATION OF ELECTRONICS
- CT----- COMMAND TRANSMITTER
- T----- TRANSMITTER
- > COMMAND LINK
- > SENSOR DATA LINK

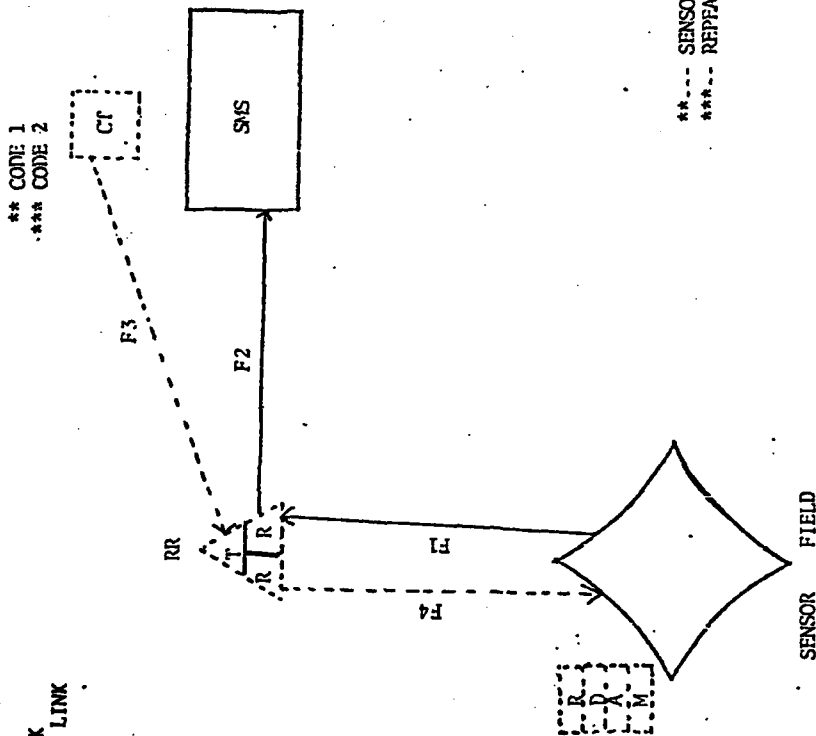

- SENSOR: ADD A RECEIVER, DECODER, ANTENNA OR DIPLEXER, ASSOCIATED ELECTRONICS, AND MODIFY BASIC CHASSIS.
- RADIO REPEATER: DEVELOP A RADIO REPEATER WHICH INCLUDES A TRANSMITTER CAPABLE OF TRANSMITTING ON TWO FREQ WITH EACH CHANNEL (SELECTION), TWO RECEIVERS, DECODER, ENCODER, DIPLEXER, SW, AND ASSOCIATED UNIQUE ELECTRONICS.
- SENSOR MONITORING SET: NO MODIFICATION REQUIRED
- COMMAND TRANSMITTER: DEVELOP A COMMAND TRANSMITTER WHICH INCLUDES A TRANSMITTER, ENCODER, ANTENNA, AND ASSOCIATED ELECTRONICS.

**--- SENSOR COMMAND (ON , OFF , ETC)
 ***--- REPEATER COMMAND (CHANGE FREQUENCY)

FIGURE 6-4A

ALTERNATIVE 4

- ①. SENSOR; ADD A RECEIVER, DECODER, ANTENNA OR DUPLEXER, ASSOCIATED UNIQUE ELECTRONICS, AND MODIFY BASIC CIRCUITS.
- ②. RADIO REPEATER: DEVELOP A RADIO REPEATER WHICH INCLUDES A TRANSMITTER (CAPABLE OF TRANSMITTING ON TWO FREQ WITH EACH CHANNEL SELECTION), TWO RECEIVERS, DECODER, ENCODER, DUPLEXER, SWP, AND ASSOCIATED UNIQUE ELECTRONICS.
- ③. SENSOR MONITORING SET: NO IDENTIFICATION REQUIRED
- ④. COMMAND TRANSMITTER: DEVELOP A COMMAND TRANSMITTER WHICH INCLUDES A TRANSMITTER, ENCODER, ANTENNA AND ASSOCIATED UNIQUE ELECTRONICS.

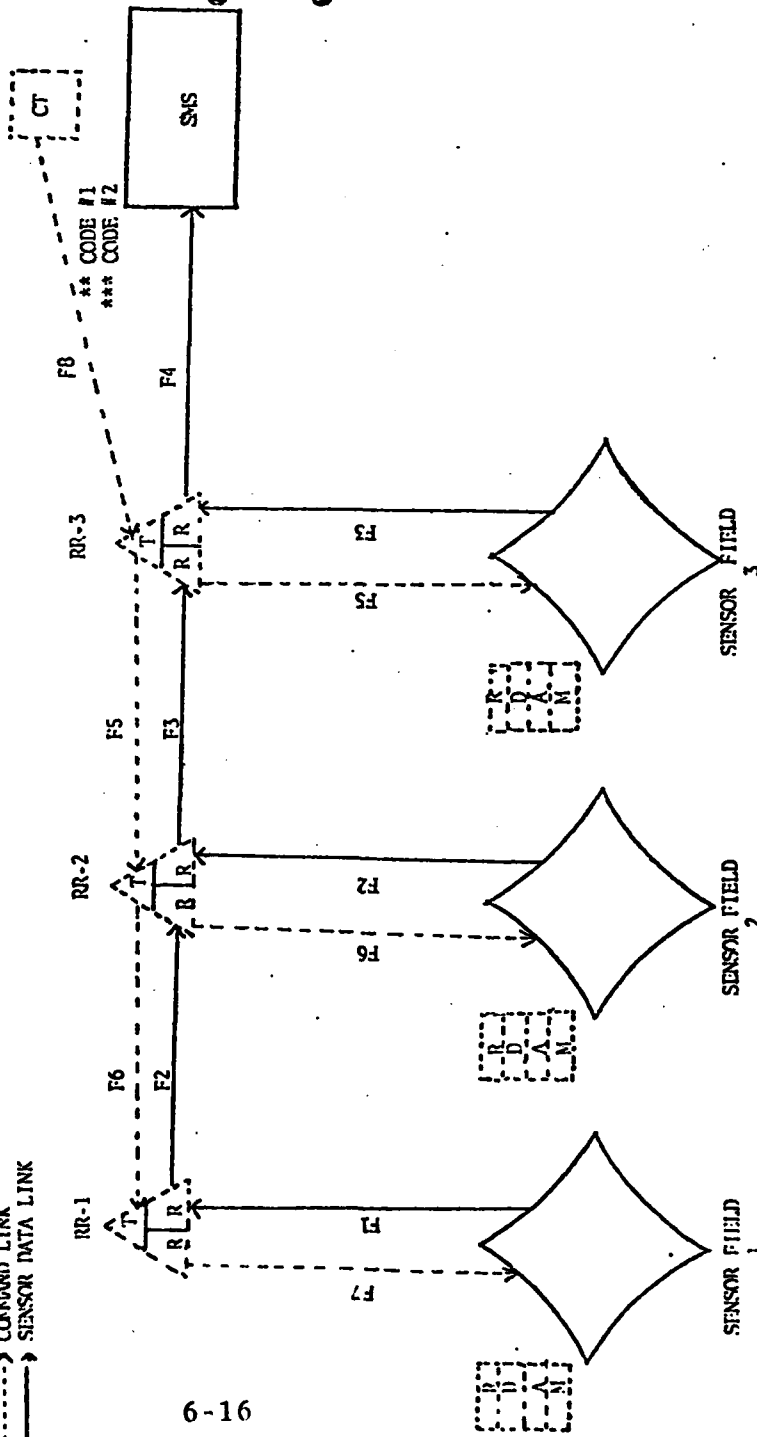
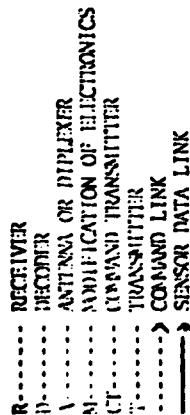

6-16

FIGURE 6-4B

**---SENSOR COMMAND (ON, OFF)
 ***---REPEATER COMMAND (CHANGE FREQUENCY)

I

The three repeater system configuration depicts traffic flow through a three repeater system for sensor data and command data using repeaters with one receiver and one transmitter. The transmitter has the capability of selecting one of 2 channels (A or B) through special coding in the message format. For the purpose of discussion Channel A represents data traffic and Channel B represents command traffic. Sensor data information is transmitted to RR-1 from Sensor Field 1 on frequency F1. The message is processed and is transmitted on Channel A (F2) to RR-2. Sensor Field 2 also transmits to RR-2 on F2. The message is processed at RR-2 and Channel A (F3) is selected to retransmit to RR-3. Sensor Field 3 also transmits to RR-3 on F3. The message is processed and is retransmitted on Channel A (F4) to the SMS. The Command Transmitter (CT) transmits to RR-3 on F3. The message is processed and through coding in the message format selects Channel B (F2) for retransmitting to Sensor Field 3 and RR-2. The command message is received at RR-2 and processed for retransmission on Channel B (F1) to RR-1 and Sensor Field 2. The command message is received at RR-1 and processed for retransmission on Channel B (F5) to Sensor Field 1. Each of the repeaters will require modification for additional logic and coding for changing from Channel A to B and back.

ALTERNATIVE 5

- R----- RECEIVER
- D----- DECODER
- A----- ANTENNA OR DIPLEXER
- M----- MODIFICATION OF ELECTRONICS
- CT----- COMMAND TRANSMITTER
- T.A/B- RADIO REPEATER TRANSMITTER CHANNEL
- COMMAND LINK
- > SENSOR DATA LINK

1. SENSOR: ADD A RECEIVER, DECODER, ANTENNA OR DIPLEXER, ADDITIONAL UNIQUE ELECTRONICS, AND MODIFY BASIC CHASSIS

2. RADIO REPEATER: DEVELOP A RADIO RADIO REPEATER WITH ONE RECEIVER AND ONE TRANSMITTER. THE TRANSMITTER HAS A TWO CHANNEL CAPABILITY USING CIRCUIT LOGIC TO SELECT CHANNEL A OR B AS REQUIRED.

3. SENSOR MONITORING SET: NO MODIFICATION REQUIRED.

4. COMMAND TRANSMITTER: DEVELOP A COMMAND TRANSMITTER WHICH INCLUDES A TRANSMITTER, ENCODER ANTENNA AND ASSOCIATED UNIQUE ELECTRONICS.

***--- CODE 1
 ****--- CODE 2

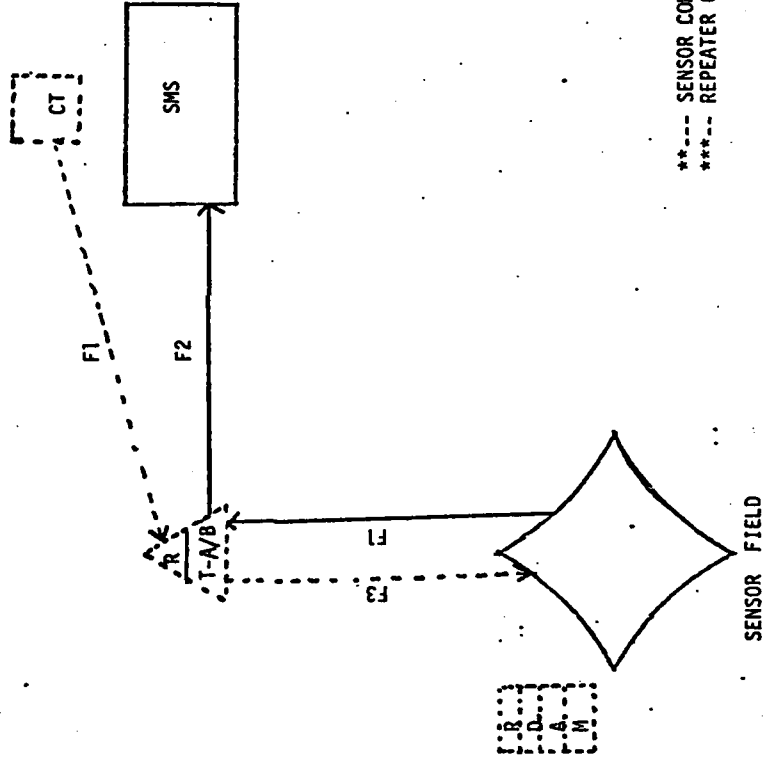

***--- SENSOR COMMAND (ON, OFF, etc)
 ****--- REPEATER COMMAND (CHANGE TRANSMIT CHANNEL)

FIGURE 6-5A

ALTERNATIVE 5

3. SENSOR: ADD A RECEIVER, DECODER, ANTENNA OR DIPLEXER, ADDITIONAL UNIQUE ELECTRONICS, AND MODIFY BASIC CHASSIS.

4. RADIO REPEATER: DEVELOP A RADIO REPEATER WHICH INCLUDES ONE RECEIVER AND ONE TRANSMITTER. THE TRANSMITTER IS CHANGED FROM CHANNEL A TO B AND BACK THROUGH LOGIC CIRCUITS IN THE REPEATER.

5. SENSOR MONITORING SET: NO MODIFICATION REQUIRED

6. COMMAND TRANSMITTER: DEVELOP A COMMAND TRANSMITTER WHICH INCLUDES A TRANSMITTER, ENCODER, ANTENNA AND ASSOCIATED UNIQUE ELECTRONICS.

- R----- RECEIVER
- D----- DECODER
- A----- ANTENNA OR DIPLEXER
- H----- MODIFICATION OF ELECTRONICS
- CT----- COMMAND TRANSMITTER
- T, A/B----- RADIO REPEATER TRANSMITTER CHANNEL
- > COMMAND LINK
- > SENSOR DATA LINK

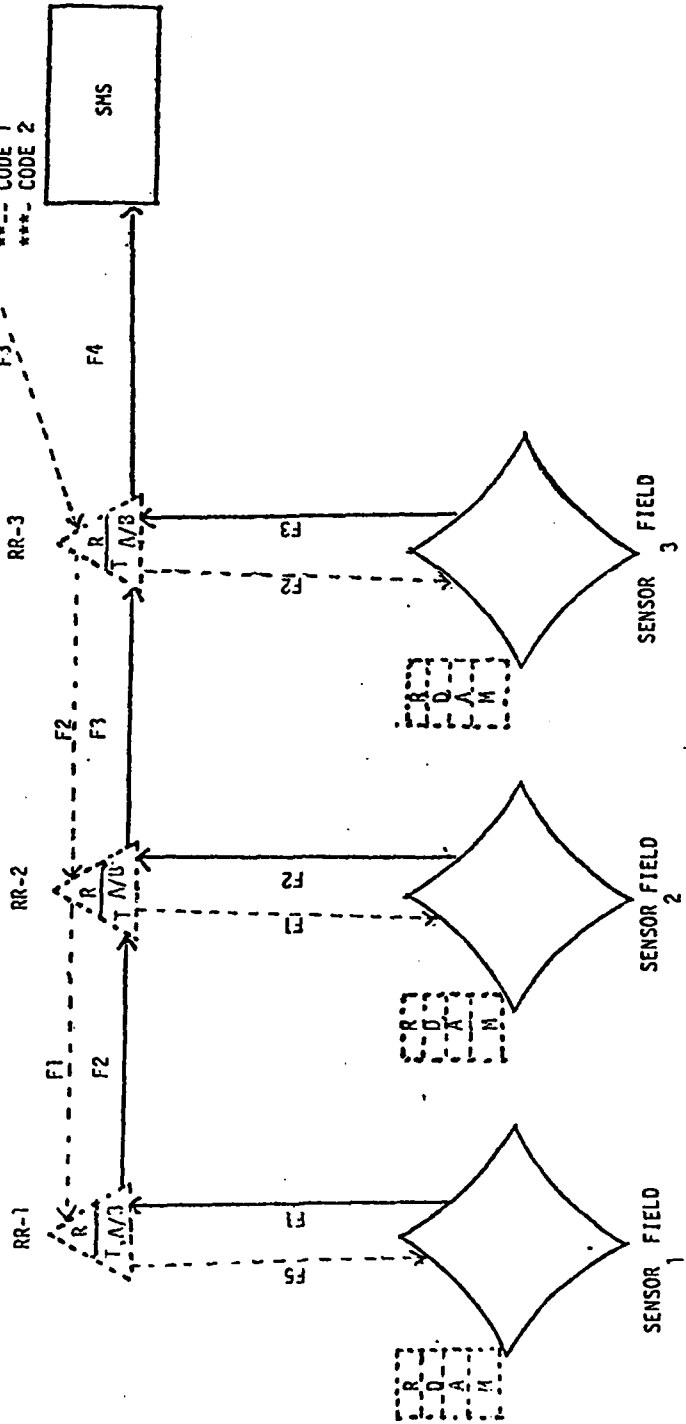

6-19

FIGURE 6-5B

----- SENSOR COMMAND (ON, OFF, etc)
 ----- REPEATER CHANNEL (CHANGE TRANSMIT CHANNEL)

6.3.6 Alternative 6

Commandability is accomplished in this alternative through direct communication with the sensors. The repeaters in the Data Transmission System are not used for Commandability. Both, a single repeater configuration (Figure 6-6A) and a three repeater configuration (Figure 6-6B) are used as illustrations. For the purpose of this discussion, only the three repeater configurations will be discussed operationally.

The three repeater configuration shows both the sensor data and command data flow for the system. The sensor data from Sensor Field #1 is transmitted to RR-1 on Frequency F1. RR-1 retransmits data to RR-2 on F2. (Sensor Field #2 also transmits to RR-2 on F2.) RR-2 retransmits to RR-3 on F3 (Sensor Field #3 also transmits to RR-3 on F3.) RR-3 retransmits to the SMS on F4. In this alternative the Command Transmitter does not utilize the radio repeater but transmits directly to the sensor. Using this type of arrangement the Command Transmitter would operate line-of-site with sensors and be located at team level or could be operated from an aircraft. The sensors would have to be modified as in other alternatives and a Command Transmitter developed. All other end items would remain unchanged.

ALTERNATIVE 6

- R-----RECEIVER
- D-----DECODER
- A-----ANTENNA OR DIPLXER
- N-----MODIFICATION OF ELECTRONICS
- CT-----COMMAND TRANSMITTER
- > COMMAND LINK
- > DATA LINK

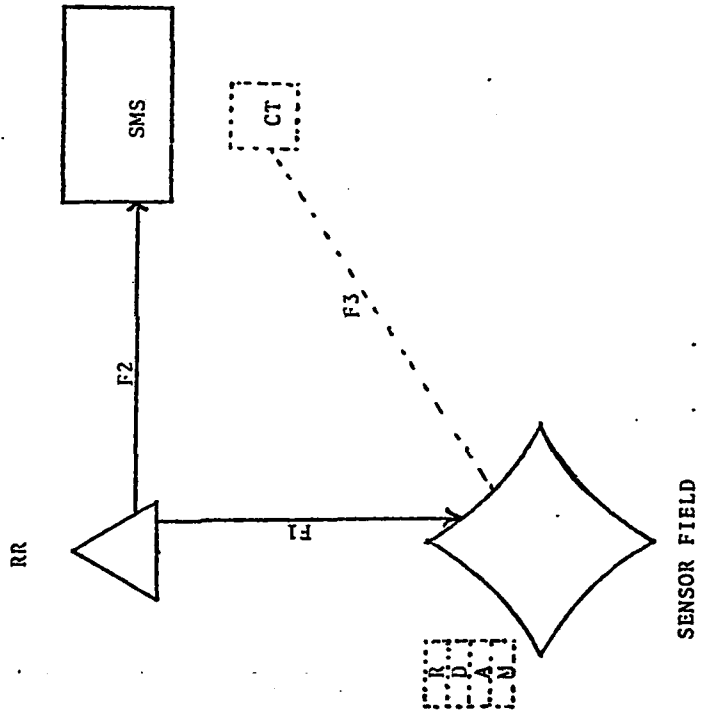

FIGURE 6-6A

ALTERNATIVE 6

- O. SENSOR: ADD A RECEIVER, DECODER, ANTENNA OR DIPLEXER, ADDITIONAL UNIQUE ELECTRONICS, AND MODIFY BASIC CHASSIS
- O. RADIO REPEATER: NO CHANGES REQUIRED.
- O. SENSOR MONITORING SET: NO CHANGE REQUIRED.
- O. COMMAND TRANSMITTER: DEVELOPE A COMMAND TRANSMITTER WHICH INCLUDES A TRANSMITTER, ENCODER, ANTENNA AND ASSOCIATED ELECTRONICS.

- R-----RECEIVER
- D-----DECODER
- A-----ANTENNA OR DIPLEXER
- N-----MODIFICATION OF ELECTRONICS
- CT-----COMMAND TRANSMITTER
- > COMMAND LINK
- > DATA LINK
- RR-1

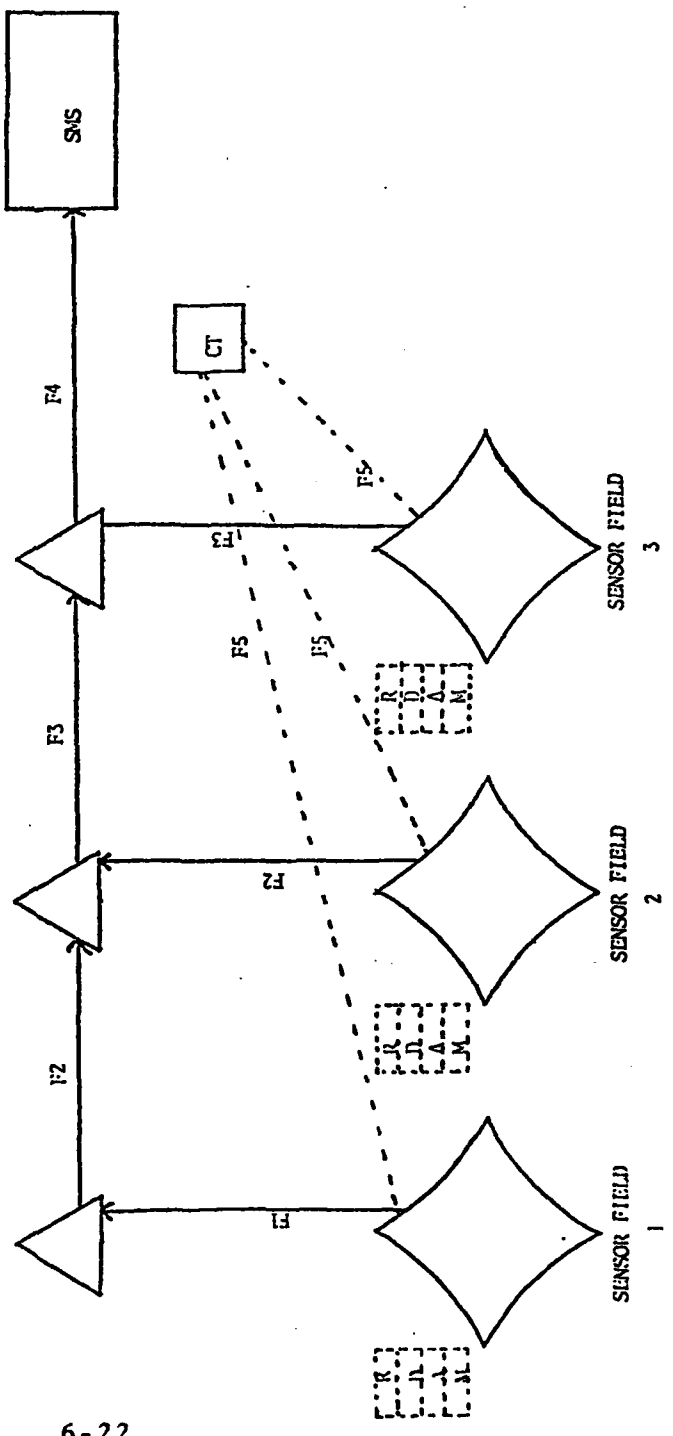

FIGURE 6-6B

6.4 SALIENT FEATURES

The salient features of each alternative method are listed by alternative in general terms below:

- Alternative 1.
 - System uses Basic REMBASS unmodified repeater.
 - Command and Sensor Data transmitted over some time shared frequency.
 - 1-2 rf channel required.
 - The repeater requirements per site remains the same as Basic REMBASS.
- Alternative 2.
 - Uses Basic REMBASS unmodified repeaters.
 - Separate DTS used for Command/Sensor traffic.
 - 1-8 rf channels per system are required.
 - Repeater requirements for each site are doubled.
- Alternative 3.
 - A major modification of Basic REMBASS repeater is required.
 - Separate DTS used for Command/Sensor traffic.
 - 1-8 rf channel(s) per system is/are required.
 - Number of repeaters per site remains the same as Basic REMBASS.
 - Weight of the repeater increases 60-70% over Basic REMBASS.
 - SIRS/ICS concepts must be integrated into repeater ED models.

- Alternative 4.

- Major modification of Basic REMBASS repeater is required.
- Separate transmit/receive rf channels for Command/Sensor data link.
- 1-8 rf channel(s) per system is/are required.
- Number of repeaters per site remains the same as Basic REMBASS.
- Weight of the repeater increases 30-40%.

- Alternative 5.

- Minimum modification required of Basic REMBASS repeater.
- Separate DTS for repeater Command/Sensor data transmit traffic. Common receiver is shared for receive side for Command/Sensor data.
- 1-5 rf channel(s) per system is/are required.
- Number of repeaters per site remains the same as Basic REMBASS.
- Weight of repeater is estimated to increase 5 per cent.

- Alternative 6.

- Repeaters are not used in this alternative.
- Line of site is required between CT and Command/Sensor.
- 1-5 rf channel(s) is/are per system required.

VII. ANALYSIS OF ALTERNATIVES

7.1 GENERAL

Each of the alternatives will be analyzed and evaluated with respect to the categories below:

- Cost
 1. Expected Hardware Cost for each alternative.
 2. The expected Average Unit Cost increase of REMBASS MSE affected.

- Logistics Support
 1. Size
 2. Weight
 3. No. of new items
 4. Special handling
 5. Training

- Performance
 1. Number of channels required
 2. RFI probability
 3. Expected message loss
 4. Improvement in quality of data collected

- RAM Impact
 1. Reliability
 2. Availability
 3. Maintainability

- Miscellaneous
 1. Growth potential
 2. Degree of use of existing hardware

7.1.1 Sensor Weight and Size/Cube

Regardless of the alternative selected, it is estimated that the addition of a command capability will increase the weight and size of all commandable sensors approximately 1 to 2% over Basic REMBASS if only "electronic commands" are used. The majority of the increase is due to the addition of a receiver, decoder, T/R switch and associated electronics. The weight and size increase does not include additional batteries if required. If "mechanical movement" functions (Panning or Zooming) are required, the weight and size is expected to increase 20 to 30% due to the addition of servos and associated electronics.

7.1.2 Command Transmitter Weight and Size/Cube

The Command Transmitter (CT) is expected to weigh approximately 5-6 pounds and be approximately 150 cubic inches in size. The component make up of the CT includes a transmitter, encoder, program/synthesizer, antenna, battery, and associated electronics.

7.1.3 Sensor Monitor Set Weight/Size/Cube

Adding a command capability will have no affect on the size and weight of the Sensor Monitor Set.

7.2 ALTERNATIVE 1

7.2.1 Cost Impact

As configured in Alternative 1, the addition of commandability to Basic REMBASS required modification of the Hand Emplaced Analog Acoustic Sensor and the Imaging Sensor; and the development of a Command Transmitter. The estimated cost impact of this effort is delineated below in Table 7-1. Quantities for each of the MSE categories and Commandability Hardware Requirements were developed from the component breakdown list in Figure 7-1. Additional methodology and supporting documentation used to develop these costs are provided in Appendix A.

TABLE 7-1.

COST IMPACT: Alternative 1

| Commandability Hardware Requirements | Quantity per REMBASS MSE Category | | | Total Quan. Req. | Estimated Avg. Unit Cost (FY77\$) | Estimated Total Cost (FY77\$) | |
|--|-----------------------------------|-------------------|------------------------|------------------------|---|-------------------------------------|-------------|
| | HEASS (DT-563) | Imaging Sensor | Command Transmitter | | | | |
| Transmitter | 0 | 0 | 628 | 628 | 225 | 141,300 | |
| Receiver | 3,092 | 3,092 | 0 | 6,184 | 425 | 2,628,200 | |
| Decoder | 3,092 | 3,092 | 0 | 6,184 | 233 | 1,440,872 | |
| Encoder | 0 | 0 | 628 | 628 | 86 | 55,380 | |
| T/R Switch | 3,092 | 3,092 | 0 | 6,184 | 95 | 587,480 | |
| Prog/Synth. | 0 | 0 | 628 | 628 | 126 | 79,128 | |
| Chassis | 3,092 | 3,092 | 628 | 6,812 | 19 | 129,428 | |
| Antenna w/Assoc.Elec. | 0 | 0 | 628 | 628 | 56 | 35,168 | |
| TCVCXO | 0 | 0 | 628 | 628 | 186 | 116,808 | |
| Battery (BA-5590) | 3,092 | 3,092 | 628 | 6,812 | 35 | 238,420 | |
| TOTAL COMMANDABILITY COST | | | | | | = | \$5,450,184 |

Note 1: Command Transmitter (CT) requires a development effort. CT does not exist in Basic REMBASS.

Note 2: Imaging Sensor presently in advance development.

Note 3: All numbers in parentheses are the additional quantities of equipments/hardware items required to add command-ability to Basic REMBASS based upon a 24 division force structure.

Commandable
REMBASS
Alternative 1

Note 3
(3092)

| |
|-------------------|
| DT-563 (Basic) |
| Chassis (1) |
| BA-5590 (1) |
| Receiver (1) |
| Decoder (1) |
| T/R Switch(1) |

Note 2
(3092)

| |
|------------------------------|
| Imaging Sensor (Basic) |
| Chassis (1) |
| BA-5590 (1) |
| Receiver (1) |
| Decoder (1) |
| T/R Switch (1) |

Note 1
(628)

| |
|-----------------------------|
| Command Transmit- ter |
| Chassis (1) |
| BA-5590 (1) |
| Transmitter (1) |
| Encoder E/D V Req(1) |
| Antenna/AssocElec(1) |
| Program/Synth (1) |
| TCVCXO (1) |

Figure 7-1. Alt. 1 Add on Component Breakdown

7.2.2 Logistic Support

Logistic support for this alternative will not be significantly affected by the addition of Commandability. The repeater remains operationally the same with no modifications required. The Prescribed Load List (PLL) and float MSE will show a slight increase due to the modification of the commandable sensors and the development of a Command Transmitter (CT). Additional operator and maintenance training will be added to the MOS Courses. Special handling, storage and transportation requirements will be significant.

7.2.3 Performance

While this alternative is attractive from a logistics and cost standpoint, the overall performance is expected to experience sufficient degradation to render it unsatisfactory as a system. Adjacent repeaters are transmitting and receiving on the same rf channel, as the sensor data link and command data link share the same channels. This will cause adjacent repeater rf interference and spatial ring around resulting in a "locked up" system. There will be a significant increase in the number of blocked and lost messages. The net end result being that the data collected at the sensor would be blocked or lost as it is being transmitted over the DTS.

7.2.4 RAM Impact

- Reliability: The addition of command features as discussed in Alternative 1 will have only a slight impact on the predicted reliability (MTBF) of the overall system. Overall predicted reliability of the system in this alternative is .823 as depicted in Appendix B (Figure B-2).

● Availability: Since system availability is a function of reliability and maintainability, the availability of Commandable REMBASS will not be significantly different from that of Basic REMBASS.

● Maintainability: No significant change will occur as the result of adding commandability. Hand Emplaced MSE will continue to be considered expendable/recoverable. Return of the system to an operational status will normally be by replacement of modular assemblies/boards. While the MTTR of the boards will remain the same, the average MTTR of the modified MSE will show a very slight increase due to the number of boards they contain. The MTTR of the Command Transmitter was considered and found to have minimal impact on the overall MTTR of the system.

7.2.5 Other Considerations

○ Basic REMBASS Hardware Utilization: Maximum use is made of Basic REMBASS hardware in this Alternative.

○ Growth Potential: This Alternative does not enhance the growth of the Basic System.

7.3 ALTERNATIVE 2

7.3.1 Cost Impact

As configured in Alternative 2, the addition of commandability to Basic REMBASS requires modification of the Hand Emplaced Analog Acoustic Sensor and the Imaging Sensor; the development of a Command Transmitter; and procurement of additional radio repeaters. The estimated cost impact of this effort is delineated below in Table 7-2. Quantity per Basic REMBASS category and Commandability Hardware requirements are computed from the component breakdown chart in Figure 7-2. Additional methodology and supporting documentation used to develop these costs are provided in Appendix A.

TABLE 7-2. COST IMPACT: Alternative 2

| Commandability Hardware Requirements | Quantity per REMBASS MSE Category | | | | Total Quan. Req. | Estimated Avg. Unit Cost (FY77\$) | Estimated Total Cost (FY77\$) |
|--------------------------------------|-----------------------------------|----------------|-------------|---------------|------------------|-----------------------------------|-------------------------------|
| | HEASS (DT-563) | Imaging Sensor | Com. Trans. | Radio Repeat. | | | |
| Transmitter | 0 | 0 | 628 | 0 | 628 | 225 | 141,300 |
| Receiver | 3,092 | 3,092 | 0 | 0 | 6,184 | 425 | 2,628,200 |
| Decoder | 3,092 | 3,092 | 0 | 0 | 6,184 | 233 | 1,440,872 |
| Encoder | 0 | 0 | 628 | 0 | 628 | 84 | 53,380 |
| T/R Switch | 3,092 | 3,092 | 0 | 0 | 6,184 | 95 | 587,480 |
| Prog/Synth. | 0 | 0 | 628 | 0 | 628 | 126 | 79,128 |
| Chassis | 3,092 | 3,092 | 628 | 0 | 6,812 | 19 | 129,428 |
| Antenna w/Assoc.Elec. | 0 | 0 | 628 | 0 | 628 | 56 | 35,168 |
| TCVCXO | 0 | 0 | 628 | 0 | 628 | 186 | 116,808 |
| Radio Repeater (RT-1175) | 0 | 0 | 0 | 3,092 | 3,092 | 2,266 | 7,006,472 |
| Battery (BA-5590) | 3,092 | 3,092 | 628 | 0 | 6,812 | 35 | 238,420 |
| TOTAL COMMANDABILITY COST | | | | | | = | 12,456,658 |

Note 1: Command Transmitter (CT) requires a development effort. CT does not exist in Basic REMBASS.

Note 2: Imaging Sensor presently in advance development.

Note 3: 3092 additional repeaters required for this alternative.

Commandable
REMBASS
Alternative 2

Note 3

Note 4: All numbers in parentheses are the additional quantities of equipments/hardware items required to add commandability to Basic REMBASS based upon a 24 division force structure.

Note 4

| | |
|-------------------|--------|
| DT-563 (Basic) | (3092) |
| Chassis | (1) |
| BA-5590 | (1) |
| Receiver | (1) |
| Decoder | (1) |
| T/R Switch | (1) |

Note 2

| | |
|------------------------------|--------|
| Imaging Sensor (Basic) | (3092) |
| Chassis | (1) |
| BA-5590 | (1) |
| Receiver | (1) |
| Decoder | (1) |
| T/R Switch | (1) |

Note 1

| | |
|-----------------------------|-------|
| Command Transmit- ter | (628) |
| Chassis | (1) |
| BA-5590 | (1) |
| Transmitter | (1) |
| Encoder E/DVReg | (1) |
| Antenna/AssocElec | (1) |
| Program/Synth | (1) |
| TCVCXO | (1) |

Figure 7-2. Alt. 2 Add on Component Breakdown

7.3.2 Logistic Support

The adding of a command capability to REMBASS using this alternative will require additional logistic support. While the repeater, remains the same in size and weight, the number of repeaters will double, using two repeaters at each site. This increase plus the slight increase in weight and size of the commandable sensors and the Command Transmitter will increase storage requirements, reduce the transportability capability, and increase handling requirements. Power requirements will increase significantly at the repeater sites, resulting in a requirement for an increased number of batteries as well as an increased number of repair parts. Increased training requirements will be met through the basic operator/maintenance MOS training. Because of the additional repeaters, an increase in operator and maintainability personnel must be anticipated.

7.3.3 Performance

The overall system performance of this alternative shows significant improvement over Basic REMBASS. Utilizing up to a maximum of 8 different radio frequencies in the system, adjacent repeater interference is non-existent. Blocked messages in the system are reduced providing an overall reduction in expected message loss. The net result being, that data collected by the sensors is passed through the system with no reduction in quality of the message. This system provides flexibility by utilization of repeaters as needed in the system to provide a command capability.

7.3.4 RAM Impact

- **Reliability:** The predicted reliability (MTBF) as computed in Appendix B (Figure B-3) is .776. The sensor data link and command data link are computed together showing the separate links together. If the data and command links are computed separately the predicted reliability is well above the .80 required by Paragraph 3.6.1 RBS-001.

- **Availability:** Since system availability is a function of reliability and maintainability, the availability of Commandable REMBASS will not be significantly different from that of Basic REMBASS.

- **Maintainability:** No significant change will occur as the result of adding Commandability. Hand Emplaced MSE will be considered expendable/recoverable. Return of the system to an operational status will normally be by replacement of modules/boards. The average MTTR of the modified MSE will increase very slightly due to the increase in the number of boards in the MSE. The MTTR of the Command Transmitter and additional repeaters were also considered and are expected to have significant impact on the overall system MTTR.

7.3.5 Other Considerations

- **Basic REMBASS Hardware Utilization:** Maximum use is made of Basic REMBASS hardware in Alternative 2.

- **Growth Potential:** Growth potential and flexibility is enhanced using this Alternative.

7.4 ALTERNATIVE 3

7.4.1 Cost Impact

As configured in Alternative 3, the addition of commandability to Basic REMBASS requires modification of the Hand Emplaced Analog Acoustic Sensor and the Imaging Sensor. A development effort is required for this alternative. As in the previous alternatives the development of a Command Transmitter is required. The estimated cost impact of this effort is delineated below in Table 7.3. Quantities per REMBASS MSE category and commandability computed using the component breakdown in Figure 7-3.

7.4.2 Logistic Support

The addition of a command capability using this alternative will have a major impact on logistic support. One of the major factors which must be considered is the expected increase in weight and size of the repeater. It is estimated that the increase will be approximately 60 to 70% over that of Basic REMBASS repeaters, and will not meet REMBASS specifications. The increase in weight and size of the repeater would reduce or most likely preclude any "manpack" capability. This increased weight and size coupled with the increase of the commandable sensors and the addition of a Command Transmitter (CT) will significantly increase storage, transportability, and maintenance requirements. Power consumption will increase, requiring additional quantities of batteries. Overall PLL quantities will show an increase because of increased number of components included in the MSE and the addition of a command transmitter. Operator and maintenance requirements will have to be expanded to include the changes to the basic system.

TABLE 7. COST IMPACT: Alternative 3

| Commandability Hardware Requirements | Quantity per REMBASS MSE Category | | | | Total Quan. Req. | Estimated Avg. Unit Cost (FY77\$) | Estimated Total Cost (FY77\$) |
|--|-----------------------------------|-------------------|----------------|------------------------------------|------------------------|---|-------------------------------------|
| | HEASS (DT-563) | Imaging Sensor | Com. Trans. | Dual Chan. Radio Repeater | | | |
| Transmitter | 0 | 0 | 628 | 3,092 | 3,720 | 222 | \$ 825,840 |
| Receiver | 3,092 | 3,092 | 0 | 3,092 | 9,276 | 415 | 3,849,540 |
| Decoder | 3,092 | 3,092 | 0 | 0 | 6,184 | 233 | 1,440,872 |
| Encoder | 0 | 0 | 628 | 0 | 628 | 84 | 52,416 |
| T/R Switch | 3,092 | 3,092 | 0 | 0 | 6,184 | 95 | 587,480 |
| Programmer | 0 | 0 | 628 | 3,092 | 3,720 | 126 | 468,720 |
| Chassis | 3,092 | 3,092 | 628 | 0 | 6,812 | 19 | 129,428 |
| Chassis (Mod) | 0 | 0 | 0 | 3,092 | 3,092 | 84 | 259,729 |
| Antenna w/Assoc. Elec. | 0 | 0 | 628 | 0 | 628 | 57 | 35,796 |
| TCVCXO | 0 | 0 | 628 | 3,092 | 3,720 | 183 | 680,760 |
| S&F Logic | 0 | 0 | 0 | 3,092 | 3,092 | 184 | 568,928 |
| Battery (BA-5590) | 3,092 | 3,092 | 628 | 9,276 | 16,088 | 35 | 563,080 |
| TOTAL COMMANDABILITY COST = | | | | | | | \$9,462,589 |

Note 1: Command Transmitter (CT) and repeater requires a development effort. CT does not exist in Basic REMBASS.

Note 2: Imaging Sensor presently is in advanced development.

Note 3: All numbers in parentheses are the additional quantities of equipment/hardware required to add command-ability to Basic REMBASS based upon a 24 division force structure.

Commandable
REMBASS
Alternative 3

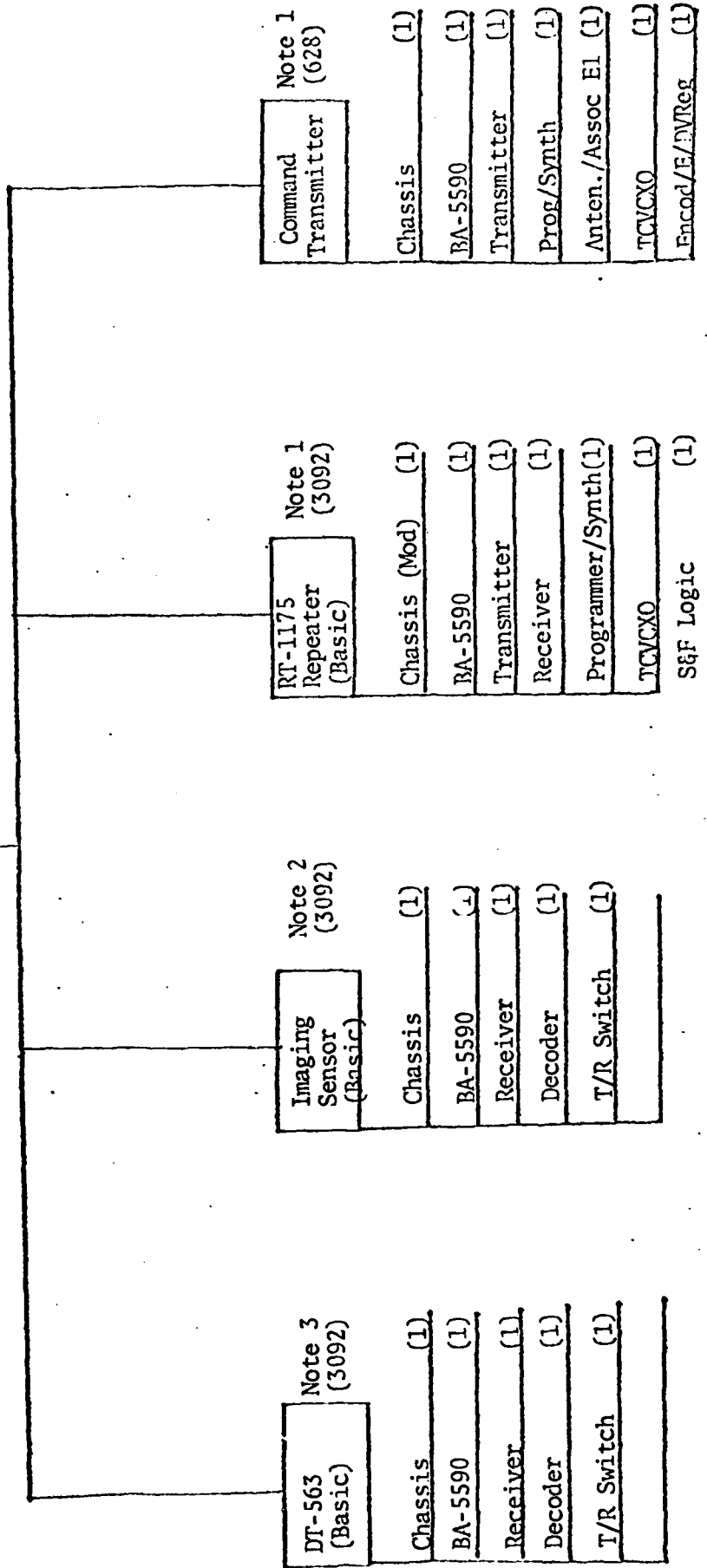

Figure 7-3. Alt. 3 Add on Component Breakdown

7.4.3 Performance

The system performance of Alternative 3 is expected to be essentially the same as in Alternative 2. Adjacent repeater radio frequency interference and spacial ring around is eliminated, thus reducing blocked and lost messages. This system although operationally the same as Alternative 2 is less desirable due to the major development effort required and the lack of flexibility.

7.4.4 RAM Impact

- o Reliability: The addition of command features as discussed in Alternative 3 would have only a slight affect on reliability (MTBF). The overall reliability of the system is .823 as shown in Appendix B (Figure B-4).

- o Availability: Since system availability is a function of reliability and maintainability, the availability of Commandable REMBASS will not be significantly different from that of Basic REMBASS.

- o Maintainability: No significant change will occur as a result of adding commandability to the system. Hand emplaced MSE are considered to be expendable/recoverable. The system is returned to operational status by the replacement of modules/boards. The MTTR of modules and sub-assemblies will remain the same; however, due to an added number of modules/boards to the system, the maintenance man-hour requirement for the system will be slightly increased.

7.4.5 Other Considerations

- o Basic REMBASS Hardware Utilization: Alternative 3 makes maximum use of Basic REMBASS modules and sub-assemblies.

7.5 ALTERNATIVE 4

7.5.1 Cost Impact

As configured in Alternative 4, the addition of commandability to Basic REMBASS requires modification of the Hand Emplaced Analog Acoustic Sensor and the Imaging Sensor. Additional efforts will also be required to modify the radio repeater for dual channel operation, and develop a Command Transmitter. The estimated cost impact is delineated below in Table 7-4. Quantities per REMBASS MSE category and commandability hardware requirements were computed using the component breakdown shown in Figure 7-4. The methodology and supporting documentation used to develop these costs are provided in Appendix A.

TABLE 7-4. COST IMPACT: Alternative 4

| Commandability Hardware Requirements | Quantity per REMBASS MSE Category | | | | Total Quan. Req. | Estimated Avg. Unit Cost (FY77\$) | Estimated Total Cost (FY77\$) |
|--------------------------------------|-----------------------------------|----------------|-------------|----------------|------------------|-----------------------------------|-------------------------------|
| | HEASS (DT-563) | Imaging Sensor | Com. Trans. | Radio Repeater | | | |
| Transmitter | 0 | 0 | 628 | 0 | 628 | 225 | 141,500 |
| Receiver | 3,092 | 3,092 | 0 | 3,092 | 9,276 | 415 | 3,849,540 |
| Decoder | 3,092 | 3,092 | 0 | 0 | 6,184 | 233 | 1,440,872 |
| Encoder | 0 | 0 | 628 | 0 | 628 | 84 | 52,416 |
| T/R Switch | 3,092 | 3,092 | 0 | 3,092 | 9,276 | 92 | 853,392 |
| Programmer | 0 | 0 | 628 | 0 | 628 | 126 | 79,128 |
| Chassis | 3,092 | 3,092 | 628 | 0 | 6,812 | 19 | 129,428 |
| Chassis (Mod) | 0 | 0 | 0 | 3,092 | 3,092 | 84 | 259,728 |
| Antenna w/Assoc. Elec.) | 0 | 0 | 628 | 0 | 628 | 57 | 35,796 |
| TCVCXO | 0 | 0 | 628 | 0 | 628 | 186 | 116,808 |
| S&F Logic | 0 | 0 | 0 | 3,092 | 3,092 | 184 | 568,928 |
| Battery (BA-5590) | 3,092 | 3,092 | 628 | 9,276 | 16,088 | 35 | 563,080 |
| TOTAL COMMANDABILITY COST = | | | | | | | \$8,090,416 |

BEST AVAILABLE COPY

Note 1: Command Transmitter (CT) and repeater requires a development effort. CT does not exist in Basic REMBASS.

Note 2: Imaging sensor presently in advanced development.

Note 3: All numbers in parentheses are additional quantities of equipments/hardware items required to add commandability to Basic REMBASS based upon a 24 division force structure.

Commandable
REMBASS
Alternative 4

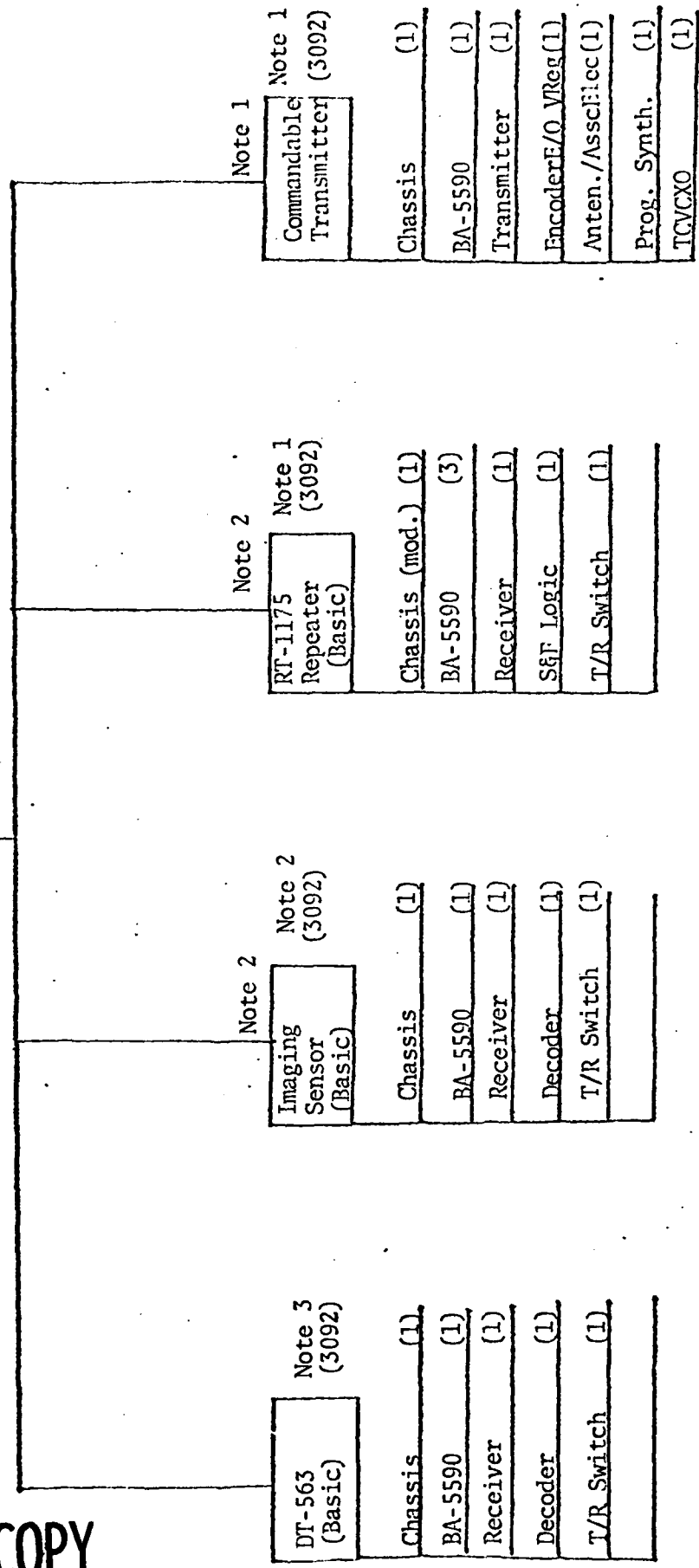

Figure 7-4. Alt. 4 Add on Component Breakdown

7.5.2 Logistic Support

The addition of commandability to REMBASS using this alternative has a moderate impact upon the logistic support requirements. It is estimated that the addition of commandability will increase the weight and size of the repeater, approximately 30 to 40%. The majority of the increase comes from addition of a receiver, battery, unique electronics and increased size of chassis. This repeater will not meet weight and size specifications for the RBS repeaters. The capability to "manpack" the repeater is greatly reduced because of weight and size increases. Storage and transportation requirements will increase as the result of the repeater and sensor modification and the Command Transmitter development. Additional training requirements will be included in the basic operator/maintenance MOS courses. Repeater power consumption is expected to increase significantly because of the added receiver.

7.5.3 Performance

The overall performance of the system is improved over Basic REMBASS and Alternative 1. The performance will be less satisfactory when compared to Alternative 2 and 3 because the system is using a single transmitter to handle both command and sensor data. Radio frequency interference is minimum using this alternative when the maximum number of frequencies are utilized. Blocked messages and message losses will be minimized. The quality of data initially collected by the sensors is not significantly degraded in the data transmission system.

7.5.4 RAM Impact

- Reliability: Predicted reliability (MTBF) of the system in Alternative 4 is .818 which is above the .80 required by Paragraph 3.6.1, RBS 001. Rationale and documentation of the reliability for this alternative is found in Appendix B (Figure B-5).

- Availability: Since system availability is a function of reliability and maintainability, the availability of commandable REMBASS will not be significantly different from Basic REMBASS.

- Maintainability: No significant change will occur as a result of adding commandability. Hand emplaced components of the system will be considered expendable/recoverable. Return of the system to an operational status will normally be by replacement of modules/boards. The MTTR of the boards will remain the same. However, there will be an increase in the number of modules/boards in the system. The average MTTR of the system will show a slight increase. There will be additional maintenance man-hour requirement over Basic REMBASS. Maintenance man-hour requirements would be approximately the same as for Alternative 2 and 3.

7.5.5 Other Considerations

- Basic REMBASS Hardware Utilization: Alternative 4 utilizes the Basic REMBASS modules/boards to a maximum extent. There is a requirement for an extensive development effort for the repeater and Command Transmitter.

• Growth Potential: Growth potential is enhanced over Basic REMBASS.

7.6 ALTERNATIVE 5

7.6.1 Cost Impact

As configured in Alternative 5, the addition of commandability to Basic REMBASS required modification of the Hand Emplaced Analog Acoustic Sensor, and the Imaging Sensor. Additional efforts will be required to modify the Radio Repeater, for dual channel operation, and to develop a Command Transmitter. The estimated cost impact is delineated below in Table 7-5. The methodology and supporting documentation used to develop these costs are provided in Appendix A. Quantity per REMBASS MSE category and commandability hardware requirements were developed by using the component breakdown structure in Figure 7-5.

TABLE 7-5. COST IMPACT: Alternative 5

| Commandability Hardware Requirements | Quantity per REMBASS MSE Category | | | | Total Quan. Req. | Estimated Avg. Unit Cost(FY77\$) | Estimated Total Cost(FY77\$) |
|--------------------------------------|-----------------------------------|----------------|-------------|----------------|------------------|----------------------------------|------------------------------|
| | HEASS (DT-563) | Imaging Sensor | Com. Trans. | Radio Repeater | | | |
| Transmitter | 0 | 0 | 628 | 0 | 628 | 225 | 141,500 |
| Receiver | 3,092 | 3,092 | 0 | 0 | 6,184 | 425 | 2,628,200 |
| Decoder | 3,092 | 3,092 | 0 | 0 | 6,184 | 233 | 1,440,872 |
| Encoder | 0 | 0 | 628 | 0 | 628 | 84 | 55,380 |
| T/R Switch | 3,092 | 3,092 | 0 | 0 | 6,184 | 95 | 587,480 |
| Programmer | 0 | 0 | 628 | 0 | 628 | 126 | 79,128 |
| Chassis | 3,092 | 3,092 | 628 | 0 | 6,812 | 19 | 129,428 |
| Chassis (Mod) | 0 | 0 | 0 | 3,092 | 3,092 | 84 | 259,728 |
| Antenna w/Assoc.Elec. | 0 | 0 | 628 | 0 | 628 | 56 | 35,168 |
| TCVCXO | 0 | 0 | 628 | 0 | 628 | 186 | 116,808 |
| Battery (BA-5590) | 3,092 | 3,092 | 628 | 0 | 6,812 | 35 | 238,420 |
| TOTAL COMMANDABILITY COST | | | | | | = | \$5,709,912 |

BEST AVAILABLE COPY

Note 1: Command Transmitter (CT) requires a development effort. CT not incl. in Basic REMBASS.

Note 2: Imaging Sensor is in adv. development.

Note 3: RT-1175 (repeater) requires chassis mod., adding logic CKTS, and assoc. elec.

Note 4: All nos. in parentheses are the add'l. quantities of equip./hardware items req. to add commandability to Basic REMBASS based upon a 24 division force structure.

Commandable
REMBASS
Alternative 5

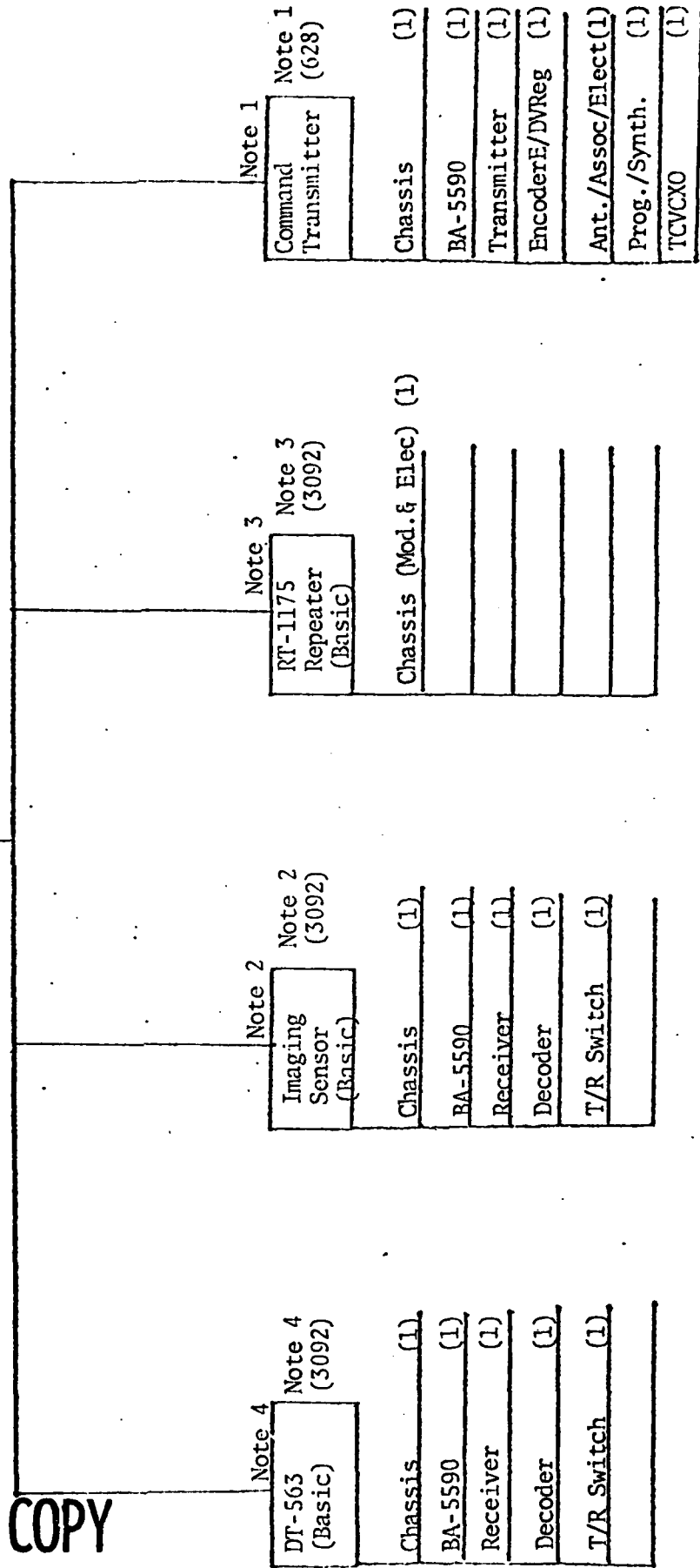

Figure 7-5. Alt. 5 Add on Component Breakdown.

7.6.2 Logistic Support

The addition of commandability using this alternative will have very little impact on logistics support. The estimated increase in weight and size of Basic REMBASS repeaters when modified is expected to be less than 5% over the REMBASS specification. This will enhance the capability for "manpack" over all other alternatives using a modified repeater or an additional repeater. The repeater for this alternative will require very little additional storage space, and no special handling. REMBASS PLL quantities would show a very slight increase, caused primarily by the modified sensors and the additional Command Transmitter. Repeater power consumption would remain essentially the same as in Basic REMBASS. Any additional training requirements will be added to the basic operator/maintenance MOS courses.

7.6.3 Performance

The performance of this system is expected to be excellent. As in Alternative 4 the only deficiency of the system (if there is one) is that the transmitter is shared by the data link and the command link utilizing two separate RF channels. The receiver also shares both links but on one frequency. If the number of command messages are kept to 30-40 per 24 hour period it is felt that the system will experience no noticeable degradation. This system reduces the number of RF channels for the system from 8 in Alternatives 2, 3 and 4 down to 5 in this Alternative without increasing RF interference and spatial ring around problems. Hence, quality data collected at the sensor moves through the system with little or no degradation.

7.6.4 RAM Impact

- Reliability: The system predicted reliability (MTBF) for Alternative 5 is .815 which exceeds the .80 requirement set forth in Paragraph 3.6.1, RBS-001. Rationale and documentation for reliability for this Alternative is found in Appendix B (Figure B-6).

- Availability: Since system availability is a function of reliability and maintainability, the availability of commandable REMBASS will not be significantly different from Basic REMBASS.

- Maintainability: No significant change is expected as the result of adding commandability. Hand Emplaced MSE will be considered expendable/recoverable. Return of the system to an operational status will be by replacement of modules/boards. The MTTR of the boards will remain the same as in Basic REMBASS. However, there will be an increase in the number of boards resulting in a very slight increase in maintenance man-hour effort for the system. The maintenance man-hour requirement will be less than in Alternative 2, 2, and 4.

7.6.5 Other Considerations

- Basic REMBASS Hardware Utilization: Alternative 5 utilizes the Basic REMBASS modules/boards to the maximum.

- Repeater Modification Effort: This alternative requires less modification to the basic Radio Repeater RT-1175 than any of the alternatives considered.

• Growth Potential: This alternative provides a greater growth potential than other alternatives.

7.7 ALTERNATIVE 6

7.7.1 Cost Impact

As configured in Alternative 6, the addition of commandability to Basic REMBASS requires modification of the Hand Emplaced Analog Acoustic Sensor and the Imaging Sensor, and the development of a Command Transmitter. The estimated cost impact of this effort is delineated below in Table 7-6. The methodology and supporting documentation used to develop these costs are provided in Appendix A. Quantity per REMBASS MSE category and commandability hardware requirements were developed using the component breakdown in Figure 7-6.

TABLE 6-10. COST IMPACT: Alternative 6

| Commandability Hardware Requirements | Quantity per REMBASS MSE Category | | | Total Quan. Req. | Estimated Avg. Unit Cost (FY77\$) | Estimated Total Cost (FY77\$) |
|--------------------------------------|-----------------------------------|----------------|---------------------|------------------|-----------------------------------|-------------------------------|
| | HEASS (DT-563) | Imaging Sensor | Command Transmitter | | | |
| Transmitter | 0 | 0 | 628 | 628 | 225 | 141,300 |
| Receiver | 3,092 | 3,092 | 0 | 6,184 | 425 | 2,628,200 |
| Decoder | 3,092 | 3,092 | 0 | 6,184 | 233 | 1,440,872 |
| Encoder | 0 | 0 | 628 | 628 | 86 | 53,380 |
| T/R Switch | 3,092 | 3,092 | 0 | 6,184 | 95 | 587,480 |
| Prog/Synth. | 0 | 0 | 628 | 628 | 126 | 79,128 |
| Chassis | 3,092 | 3,092 | 628 | 6,812 | 19 | 129,428 |
| Antenna w/Assoc.Elec. | 0 | 0 | 628 | 628 | 56 | 35,168 |
| TCVCXO | 0 | 0 | 628 | 628 | 186 | 116,808 |
| Battery (BA-5590) | 3,092 | 3,092 | 628 | 6,812 | 35 | 238,420 |
| TOTAL COMMANDABILITY COST | | | | | = | \$5,450,184 |

Note 1: Command Transmitter (CT)

requires a development effort. CT does not exist in Basic REMBASS.

Note 2: Imaging Sensor presently is in advanced development.

Note 3: All numbers in parentheses are the additional quantities of equipment/hardware required to add command-ability to Basic REMBASS based upon a 24 division force structure.

Commandable
REMBASS
Alternative 6

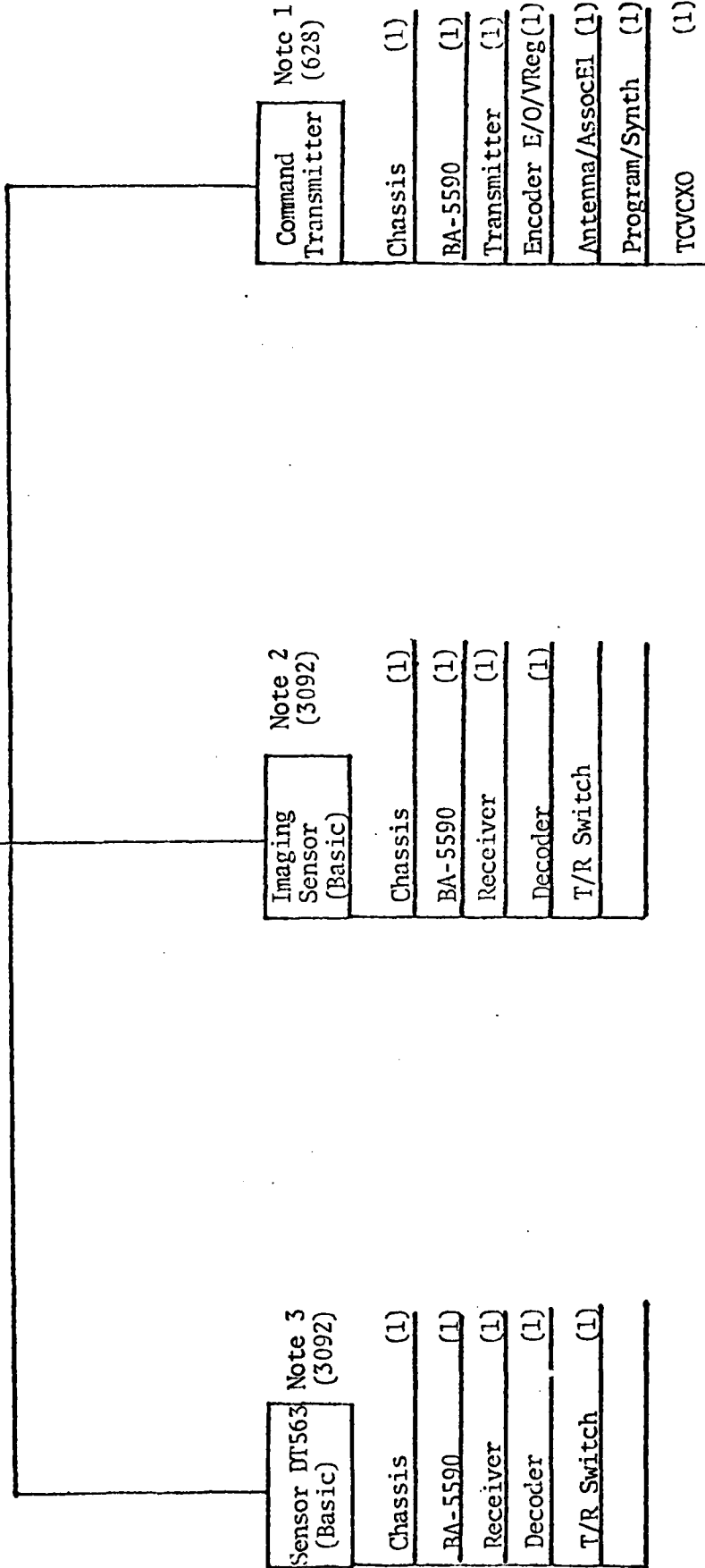

Figure 7-6. Alt. 6 Add on Component Breakdown.

7.7.2 Logistic Support

The addition of a command capability using this alternative would require little additional logistic support as far as storage, maintenance, training, and PLL is concerned. The primary increase in support requirements would come from the use of an airborne platform if required. The operational cost of the platform to support this system is expected to be substantial.

7.7.3 Performance

The performance of the system is improved over Basic REMBASS if the command transmission path is available to commandable sensors. This path would normally be met by the Command Transmitter being airborne, on a hilltop that is line-of-site to all sensor fields, or in forward areas near sensor placement. The latter would require a sufficient number of Command Transmitters assigned down at team level to allow the teams to command the sensors in their area of responsibility from a forward location. If one of the three conditions are met then this system would perform satisfactorily. Radio Frequency interference, blocked, and lost messages are reduced when conditions that are described above are met. The RF spectrum is conserved using this alternative.

7.7.4 RAM Impact

- Reliability: The system reliability for Alternative 6 is .823 which exceeds the .80 requirement set forth in Paragraph 3.6.1, RBS-001. Rationale and documentation for the reliability computation is shown in Appendix B (Figure B-7).

● Availability: Since system availability is a function of reliability and maintainability, the availability of Commandable REMBASS will not be significantly different from that of Basic REMBASS.

7.7.5 Other Considerations

● Basic REMBASS Hardware Utilization: Alternative 6 utilizes the Basic REMBASS component to a maximum extent. The only development is for a Command Transmitter. The only modification is to sensors selected for commandability.

● Growth Potential: Growth potential is not enhanced significantly using this alternative.

7.8 Summary of Analysis

A summarization of the analysis of each alternative is provided in Table 7-7.

BEST AVAILABLE COPY

| | SENSOR DT 563 / IMAGING | | SENSOR INDUCED BLOCKED MESSAGES | SENSOR NUMBER OF NEW COMPONENTS | REPEATER WEIGHT / SIZE | REPEATER BLOCKED MESSAGES | REPEATER ADDITIONAL REQUIREMENTS |
|----------------------------|---|---------------------|---|--|---|---|---|
| BASIS SYSTEM REMARKS | DT 563 DT 563 IRCA EST IMAGING EST 15 LB IMAGING EST 400 CUBIC INCHES CUBIC INCHES | 129 LB 376 cu in | BLOCKED MESSAGES DUE TO TRANSMIT TIMES OF THE DT 563 AND THE IMAGING SENSOR DURING PERIODS OF PEAK ACTIVITY AND LOCAL DISTURBANCES, ASSUMING ALL SENSORS OPERATE OVER THE TRANSMISSION SYSTEM | NONE | WEIGHT - 30 LB MAXIMUM (RBS) SIZE - 1.5 CUBIC FEET RT.1175 MAXIMUM (RBS) | PRIMARY CAUSES OF BLOCKED MESSAGES 1. EXTENDED ANALOG IMAGING SENSOR TRANSMIT TIME 2. EXTEND TIME REPEATER RECEIVE TRANSMIT TIME | N/A |
| ALT 1 | DT 563 EST 1 TO 2% INCREASE IN WEIGHT AND SIZE DEPENDING ON NUMBER AND TYPE OF COMMANDS THE SIZE AND HEIGHT OF THE IMAGING SENSOR MAY INCREASE 20% TO 30% INCREASE COMES FROM ADDITION OF MECHANICAL COMMANDS | | BLOCKED MESSAGES CAUSED BY SENSOR REDUCED IF COMMANDS SUCH AS "ON" OR "OFF" ARE INCLUDED. COMMANDS TO CONTROL TRANSMIT TIME SUCH AS "TRANSMIT" 3, 6, 10 OR 15 SECONDS, APPEAR TO BE VALID AS FAR AS REDUCING THE NUMBER OF BLOCKED MESSAGES | THERE WOULD BE AN INCREASE OF THREE SUB ASSEMBLIES OR BOARDS (RECEIVER DECODER, TR SWITCH, DIPLER) AS WELL AS THE ADDITIONAL UNIQUE ELECTRONICS REQUIRED. THERE WOULD ALSO BE A REQUIREMENT FOR SERVO AND ASSOCIATED HARDWARE FOR ANY MECHANICAL SENSOR CHANGES (PANNING). | SAME AS REMBASS 1 | PRIMARY CAUSES OF BLOCKED MESSAGE INCREASE 1. SPACIAL RING AROUND 2. COMMAND SENSOR DATA PASSED ON THE SAME CHANNEL | NONE |
| ALT 2 | SAME AS ALT 1 | | SAME AS ALT 1 | SAME AS ALT 1 | BASIC REPEATER WEIGHT SIZE SAME HOWEVER, 2 REPEATERS ARE REQUIRED AT EACH REPEATER SITE IN ALT 2 WHICH IN REALITY WOULD RESULT IN A 100% INCREASE IN WEIGHT AND SIZE OF BASIC REPEATER | BLOCKED MESSAGES ARE LESS THAN BASIC REMBASS AND ALT 1 DUE TO 1. SEPARATE SYSTEM USED FOR COMMAND SENSOR DATA 2. RF (CHANNEL) SEPARATION AT ADJACENT REPEATERS | NONE HOWEVER AN INCREASE IN REPEATERS TO SUB |
| ALT 3 | SAME AS ALT 1 | | SAME AS ALT 1 | SAME AS ALT 1 | ESTIMATED INCREASE IN WEIGHT SIZE OVER THE BASIC REPEATER WOULD BE 80 TO 70% DUE TO INCREASE IN SIZE OF CHASSIS, ADDED TRANS MITTER, RECEIVER, BATTERIES AND UNIQUE ELECTRONICS | SAME AS ALT 2 | DEVELOPMENT EFF INCLUDE THE ADDED 1. TRANSMITTER 2. RECEIVER 3. BATTERIES 4. ASSOCIATED |
| ALT 4 | SAME AS ALT 1 | | SAME AS ALT 1 | SAME AS ALT 1 | ESTIMATED INCREASE IN WEIGHT AND SIZE OVER THE BASIC REPEATER WOULD BE 30-40% DUE TO INCREASED SIZE OF CHASSIS, ADDED RECEIVER, BATTERY, AND UNIQUE ELECTRONICS | BLOCKED MESSAGES ARE LESS THAN BASIC REMBASS AND ALT 1 DUE TO 1. RF CHANNEL SEPARATION 2. LESS INTERFERENCE BLOCKED MESSAGE INCREASE OVER ALT 2 AND 3 DUE TO SHARED TRANSMITTER | DEVELOPMENT EFF INCLUDE THE ADDED 1. BATTERY 2. ASSOCIATED 3. RECEIVER |
| ALT 5 | SAME AS ALT 1 | | SAME AS ALT 1 | SAME AS ALT 1 | ESTIMATED INCREASE IN WEIGHT AND SIZE OVER THE BASIC REPEATER WOULD BE AN ESTIMATED 5% OR LESS NO ADDITIONAL REMBASS MODULES REQUIRED INVOLVES ADDING LOGIC TO ALLOW CHANGING OF TRANSMITTER FROM CHANNEL A TO B AND BACK | BLOCKED MESSAGES ARE LESS THAN BASIC REMBASS AND ALT 1 DUE TO 1. RF CHANNEL SEPARATION 2. LESS INTERFERENCE BLOCKED MESSAGES WOULD SHOW A SLIGHT INCREASE OVER ALT 2 AND 3 | DEVELOPMENT EFF INCLUDE THE ADDED CIRCUITS AND ELECTRONICS IN THE BOARD DEPENDENT UPON MODIFICATION MAY BE CONSIDERED IMPROVEMENT P |
| ALT 6 | SAME AS ALT 1 | | SAME AS ALT 1 | SAME AS ALT 1 | REPEATER IS NOT AFFECTED IN THIS APPROACH REMAINS THE SAME OPERATIONALLY AS IN BASIC REMBASS | IF COMMAND TRANSMITTER IS WITHIN RANGE OF SENSORS SAME AS ALT 2 AND 3 | |

TABLE 7-7 SUMMARY ANALYSIS

BEST AVAILABLE COPY

BEST AVAILABLE COPY

| REPEATER ADDITIONAL REMBASS COMPONENT REQUIREMENT | SYSTEM CHANNEL REQ | SYSTEM RF INTERFERENCE | SYSTEM MESSAGE LOSS | SYSTEM RELIABILITY | SYSTEM AVAILABILITY | SYSTEM MAINTAINABILITY | SYSTEM UTILIZATION OF EXISTING HARDWARE |
|--|--------------------------|---|--|---------------------------------|---|---|--|
| N/A | 1-4 | MINIMUM WHEN USING 4 RF CHANNELS IN A 3 REPEATER SYSTEM WOULD BE DEGRADED AS THE NUMBER OF RF CHANNELS IS REDUCED IN SYSTEM | IS SATISFACTORY IN MEETING REMBASS SPECIFICATIONS | 831 IRCA PROPOSAL NO 9411781 | IS SATISFACTORY IN MEETING BASIC REMBASS SPECIFICATIONS | IS SATISFACTORY IN MEETING BASIC REMBASS SPECIFICATIONS | N/A |
| NONE | 1-2 | MAXIMUM WHEN A 3 REPEATER SYSTEM USED BECAUSE OF RF CHANNEL SELECTION CAPABILITY OF THIS ALTERNATIVE | MESSAGE LOSS WILL INCREASE SIGNIFICANTLY USING THIS ALTERNATIVE DUE TO RF INTERFERENCE SPACIAL RING AROUND AND BLOCKED MESSAGES | 823 | AVAILABILITY WOULD BE AFFECTED TO A MINIMAL DEGREE BY ADDITIONAL SENSOR ELECTRONICS AND ADDITION OF A COMMAND TRANSMITTER TO SYSTEM | SLIGHT INCREASE IN OVERALL SYSTEM MTRR DUE TO ADDED CT AND SENSOR COMPONENTS. INDIVIDUAL SUBASSEMBLY MTRR REMAINS THE SAME. SHOULD NOT REQUIRE ADDITIONAL MAINT PERSONNEL | YES |
| NONE HOWEVER THERE WOULD BE AN INCREASE IN THE NUMBER OF REPEATERS TO SUPPORT THE SYSTEM | 1-8 | MINIMUM USING 8 RF CHANNELS AS NUMBER OF FREQUENCIES IN THE SYSTEM REDUCED RF INTERFERENCE INCREASES | EXPECTED MESSAGE LOSS WILL BE LESS THAN BASIC REMBASS AND ALT 1 WHEN USING A 3 REPEATER SYSTEM WITH 8 DIFFERENT RECEIVE TRANSMIT FREQUENCIES | 776 | AVAILABILITY WOULD MOST LIKELY SHOW A VERY SLIGHT DECREASE DUE TO ADDED NUMBER OF REPEATERS (COMMAND) ADDITIONAL SENSOR ELECTRONICS AND THE ADDITION OF A COMMAND TRANSMITTER TO THE SYSTEM | MODERATE INCREASE IN OVERALL SYSTEM MTRR DUE TO ADDITIONAL REPEATERS (COMMAND) AND A COMMAND TRANSMITTER AS WELL AS ADDED SUBASSEMBLIES TO THE SENSOR. POSSIBLE INCREASE IN MAINTENANCE PERSONNEL | YES HOWEVER THERE WILL BE A REQUIREMENT FOR ADDITIONAL REMBASS COMPONENTS DUE TO RP OF SENSORS DEVELOPMENT OF CT AND A REQUIREMENT FOR ADDED REPEATERS |
| DEVELOPMENT EFFORT REQUIRED TO INCLUDE THE ADDITIONAL COMMON ENTS IN THE BASIC REPEATER 1. TRANSMITTER 2. RECEIVER 3. BATTERIES 4. ASSOCIATED ELECTRONICS | 1-8 | MINIMUM USING 8 RF CHANNELS IN A 3 REPEATER SYSTEM AS NUMBER OF RF CHANNELS DECREASED RF INTERFERENCE INCREASES | SAME AS ALT 2 | 813 | AVAILABILITY WOULD BE AFFECTED VERY LITTLE WHEN COMPARED WITH THE BASIC SYSTEM. ANY CHANGE WOULD BE THE RESULT OF INCREASED NUMBER OF SUBASSEMBLIES IN THE REPEATER AND SENSOR PLUS THE COMMAND TRANSMITTER | MODERATE INCREASE IN OVERALL SYSTEM MTRR DUE TO ADDITIONAL REPEATER AND SENSOR AS WELL AS THOSE REQUIRED IN THE COMMAND TRANSMITTER. POSSIBLE INCREASE IN MAINTENANCE PERSONNEL | YES HOWEVER A DEVELOPMENT EFFORT WILL BE REQUIRED FOR THE REPEATERS AND CT AND A RP OF SENSORS |
| DEVELOPMENT EFFORT REQUIRED TO INCLUDE THE ADDITIONAL COMMON ENTS IN THE BASIC REPEATER 1. BATTERY 2. ASSOCIATED ELECTRONICS 3. RECEIVER | 1-8 | MINIMUM USING 8 RF CHANNELS IN A 3 REPEATER SYSTEM AS NUMBER OF RF CHANNELS DECREASED RF INTERFERENCE INCREASES | EXPECTED MESSAGE LOSS WILL DECREASE FROM BASIC REMBASS AND ALTERNATIVE 1. MESSAGE LOSS WOULD BE SLIGHTLY HIGHER THAN IN ALTERNATIVE 2 AND 3 | 818 | AVAILABILITY WOULD BE AFFECTED VERY LITTLE WHEN COMPARED WITH THE BASIC SYSTEM. ANY CHANGE WOULD BE THE RESULT OF INCREASED NUMBER OF SUBASSEMBLIES IN THE REPEATER SENSORS AND COMMAND TRANSMITTER | SAME AS ALT 3 | SAME AS ALT 3 |
| DEVELOPMENT EFFORT REQUIRED TO INCLUDE THE ADDITIONAL LOGIC CIRCUITS AND ASSOCIATED ELECTRONICS IN THE BASIC REPEATER DEPENDING UPON THE DEGREE OF MODIFICATION REQUIRED THIS EFFORT MAY BE CONSIDERED A PRODUCT IMPROVEMENT PROGRAM | 1-5 | MINIMUM USING 5 RF CHANNELS IN A 3 REPEATER SYSTEM AS NUMBER OF RF CHANNELS DECREASES RF INTERFERENCE INCREASES | SAME AS ALT 1 | 823 | SAME AS ALT 4 | SAME AS ALT 1 | SAME AS ALT 1 |
| NONE | 1-5 | MINIMUM WHEN USING 5 RF CHANNELS IN A 3 REPEATER SYSTEM AS NUMBER OF RF CHANNELS DECREASES RF INTERFERENCE INCREASES | SAME AS ALT 2 AND 3 | 823 | NO NOTICEABLE EFFECT COMPARED TO BASIC REMBASS | SLIGHT INCREASE IN OVERALL SYSTEM MTRR DUE TO ADDITION OF COMMAND TRANSMITTER AND MODIFICATION OF SENSORS. MTRR OF SUBASSEMBLIES REMAINS THE SAME | YES |

ANALYSIS OF ALTERNATIVES

VIII. RECOMMENDATION

8.1 RECOMMENDED ALTERNATIVE

Alternative 5 is selected as the most desirable and is recommended as the system to be used for adding a command capability.

8.2 EVALUATION METHODOLOGY

Each alternative was evaluated and received a subjective ranking based on the set of operational enhancement criteria described below.

- Weight - The weight of each modified component or developed item in each alternative is compared against Basic REMBASS and other alternatives.

- Size/Cube - The size of each modified component or developed item in each alternative is compared against Basic REMBASS component and other alternatives.

- RF Requirement - Each alternative was evaluated for RF channel requirements against Basic REMBASS and other alternatives.

- RF Interference - Each alternative was evaluated against Basic REMBASS and other alternatives for predicted RF interference.

- Blocked messages - Each alternative was evaluated against Basic REMBASS and other alternatives as to the probability of an increase or decrease in the number of blocked messages.

- Message Loss - Each alternative was evaluated against Basic REMBASS and other alternatives, as to the expected message loss.

- Reliability - A reliability assessment was made on each alternative reflecting the predicted reliability for each system.

- Availability - Each alternative was assessed as expected impact on system availability that the adding of commandability would have on each alternative.

- Maintainability - Maintainability of the system was evaluated for each alternative from both a scheduled and an unscheduled maintenance standpoint.

● Cost - Each alternative was assessed as to the expected increase in cost for the additions of commandability.

● Number of New Components - Each alternative was evaluated as to the number of new components (REMBASS) required as compared to Basic REMBASS and other alternatives.

● Utilization of Existing Hardware - Each alternative was evaluated from a standpoint of utilization of existing boards/assemblies from Basic REMBASS.

● Power Budgeting - The power consumption of each alternative was evaluated and shown as; a small increase, medium increase or large increase in expected required power for the commandable sensor and modified or developed repeaters.

8.3 ALTERNATIVE COMPARISON

Table 8-1 is provided in which a subjective ranking of each alternative is presented based on the operational enhancement criteria discussed in paragraph 8.2. The "enhancement value" of the criteria as they apply to each alternative were rated over the following scale:

- High value = 4
- Medium value = 3
- Low value = 2
- Very low value = 1
- No value = 0

8.4 DISCUSSION OF RECOMMENDED ALTERNATIVE

Alternative 5 is considered to be superior over Alternatives 1, 2, 3, 4, and 6 and is therefore the most desirable

TABLE 8-1. OPERATIONAL ENHANCEMENT EVALUATION

| ALTERNATIVE CRITERIA | ALT 1 | ALT 2 | ALT 3 | ALT 4 | ALT 5 | ALT 6 |
|----------------------------------|----------|----------|----------|----------|----------|----------|
| WEIGHT/CUBE | 4 | 3 | 1 | 1 | 4 | 4 |
| CHANNEL REQ. RFI/EMI | **0 | 4 | 4 | 4 | 4 | 3 |
| BLOCKED MESSAGES/MESSAGE LOSS | **0 | 4 | 4 | 4 | 4 | 2 |
| SYSTEM RAM-D | 4 | 3 | 4 | 4 | 4 | 4 |
| COST IMPACT | 4 | 2 | 2 | 2 | 4 | 4 |
| NEW COMPONENT REQUIREMENT | 4 | 4 | 3 | 2 | 4 | 4 |
| UTILIZATION OF EXISTING HARDWARE | 4 | 4 | 3 | 3 | 4 | 3 |
| POWER BUDGETING | 4 | 1 | 1 | 1 | 4 | 4 |
| TOTAL WEIGHTING VALUE | **24 | 25 | 22 | 21 | 32 | 28 |

** Alternative 1 is considered least desirable of alternatives considered because of RFI/EMI interference resulting in an unacceptable number of Blocked/Lost messages

Weighting: High Value = 4 Very Low Value = 1
 Medium Value = 3 No Value = 0
 Low Value = 2

approach for adding a command capability to REMBASS. This alternative will have the least impact on Basic REMBASS while providing the operational performance capability desired by the user. Performance, logistics, blocked messages, lost messages, weight, size, power consumption, frequency utilization, and cost considerations were considered to be major advantages for selecting Alternative 5. While no repeater modifications were required for Alternative 2, an additional 3092 repeater would be required to fully support the command system. This alternative is considered superior over Alternative 6 from an operational standpoint. The capability of providing a command data repeater link where line-of-site does not exist is considered to be a required feature of the system. Alternative 6 does not provide this capability without an airborne platform or without using Basic REMBASS repeaters called out in the BOIP for use in the sensor data link. While Alternatives 3 and 4 provide an equal operational capability, they are considered to be inferior from an overall size, weight, power consumption, modifications required, and cost parameters. Alternative 1 is considered to be least desirable because of spatial ring around, radio frequency interference, blocked messages, and lost messages resulting in unsatisfactory system performance even though it was ranked higher than Alternatives 3 and 4.

APPENDIX A

REMBASS COMMANDABILITY COST IMPACT

The cost estimate for the addition of commandability to Basic REMBASS, as configured in each of the six alternatives discussed in this study, can be arrived at by estimating the cost of the additional equipments required, taking into account commonality with Basic REMBASS hardware items (i.e., total procurement quantities of hardware items required for a commandable system) and utilizing experience curve theory. However, inasmuch as cost data pertaining to specific hardware items at the detail levels of the Basic REMBASS Work Breakdown Structure (WBS) are not currently available, cost estimating will be done by analogy.

Table A-1 provides cost data pertaining to hardware items which are analogous to those required for Basic REMBASS and Commandable REMBASS: The first column delineates the specific hardware items; the second column lists the average unit cost of these items (escalated to FY77\$)--these costs were obtained either from the most recent applicable Army contract or as best engineering estimates ^①, as indicated in the third column; the fourth column delineates estimates of the total quantities of the hardware items procured through the most recent contract ^②; the fifth column lists estimates of the first unit cost of each hardware item (with the exception of the BA-5590 battery ^③), arrived at by using the formula

$$C(X) = U X^B, \quad (A1)$$

which follows from experience curve theory, where

B = Experience curve exponent

X = Total quantity of procured items

U = First unit cost of procured item
C(X) = Average unit cost of X items

The value of B was calculated to be -0.1520 by assuming (conservatively) a 90% experience curve slope, except in the case of the Radio Repeater (RT-1175), where B was taken to -0.2176, corresponding to an 86% experience curve slope (based upon current contractor DTUPC projections ④). The last column lists the quantities of hardware/sub assemblies items required for Basic REMBASS, based upon a 24 division force structure. ⑤

TABLE A-1. COST DATA

| Hardware Item | Average Unit Cost (FY77\$) | Source | Total Quantity Procured ^② | First Unit Cost (FY77\$) | Basic REMBASS Quantity ^⑤ |
|-------------------------------------|----------------------------|-----------------------|--------------------------------------|--------------------------|-------------------------------------|
| Transmitter (T-1143) | 226 | DAAB07-75-C-0123 | 40,000 | 1,131 | 41,452 |
| Receiver (R-1641) | 593 | DAAB07-73-C-0123 | 2,000 | 1,883 | 11,788 |
| Decoder (KY-676) | 222 | DAAB07-73-C-0014 | 25,000 | 1,035 | 11,788 |
| Encoder (KY-678) | 74 | DAAB07-73-C-0015 | 100,000 | 426 | 41,452 |
| T/R Switch | 129 | DAAB07-76-C-0194 | 2,000 | 410 | 9,276 |
| Programmer/Synthesizer | 250 | Estimate ^① | 500 | 643 | 44,544 |
| Chassis | 25 | Estimate ^① | 1,000 | 71 | 0 |
| Chassis (Mod.) | 100 | Estimate ^① | 1,000 | 286 | 0 |
| Antenna (w/ associated electronics) | 100 | Estimate ^① | 1,000 | 286 | 43,946 |
| TCVCXO | 370 | Estimate ^① | 500 | 952 | 47,056 |
| S&F Logic | 300 | Estimate ^① | 500 | 772 | 9,276 |
| Radio Repeater (RT-1175) | 2,634 | DAAB07-77-C-3298 | 3,092 | 15,141 | 3,092 |
| Battery (BA-5590) | 35 | Estimate ^③ | -- | -- | 50,100 |

The costs presented in Tables 5-5 to 5-10 were derived based upon the data given in Table A-1 and equation (A-1): The estimated average unit cost of each hardware item necessary for commandability was obtained by utilizing equation (A1) with the first unit cost $C(X)$ from Table A-1 and the quantity X given by the sum of the quantities needed for Basic REMBASS (in Table A-1) and the additional quantities required for commandability (in Tables 5-5 to 5-10 and Figures A-1 to A-6); an experience curve exponent $B = -0.1520$ was used for all hardware items, except the Radio Repeater, where $B = -0.2176$ was used (see explanation following equation (A1)). The total cost associated with each hardware item was then obtained by multiplying the quantity of items required for commandability by their average unit cost.

① PMO REMBASS.

② PMO REMBASS.

③ It is anticipated that the Army will be procuring BA-5590 batteries in lots of 1 million (PMO REMBASS); the ET&D Labs, Power Sources Division estimates the resulting average unit cost of the BA-5590 battery to be \$35.

④ ED contract (DAAB07-77-C-3298) with RCA.

⑤ Revised REMBASS BOIP-II, Oct. 1977 (Intelligence School).

Note 1: Command Transmitter (CT) requires a development effort. CT does not exist in Basic REMBASS.

Note 2: Imaging Sensor presently in advance development.

Note 3: All numbers in parentheses are the additional quantities of equipments/hardware items required to add command-

Commandable
REMBASS
Alternative 1

Note 3
(3092)

DT-563
(Basic)

| | |
|------------|-----|
| Chassis | (1) |
| BA-5590 | (1) |
| Receiver | (1) |
| Decoder | (1) |
| T/R Switch | (1) |

Note 2

Imaging
Sensor
(Basic)

(3092)

| | |
|------------|-----|
| Chassis | (1) |
| BA-5590 | (1) |
| Receiver | (1) |
| Decoder | (1) |
| T/R Switch | (1) |

Note 1

Command
Transmit-
ter

(628)

| | |
|-------------------|-----|
| Chassis | (1) |
| BA-5590 | (1) |
| Transmitter | (1) |
| Encoder E/D V Req | (1) |
| Antenna/AssocElec | (1) |
| Program/Synth | (1) |
| TCVCXO | (1) |

Figure A-1. Alt. 1 Add on Component Breakdown

- Note 1: Command Transmitter (CT) requires a development effort. CT does not exist in Basic REMBASS.
- Note 2: Imaging Sensor presently in advance development.
- Note 3: 3092 additional RT-1175 repeaters required for this alternative.

Commandable
REMBASS
Alternative 2

Note 3

Note 4: All numbers in parentheses are the additional quantities of equipments/hardware items required to add commandability to Basic REMBASS based upon a 24 division force structure.

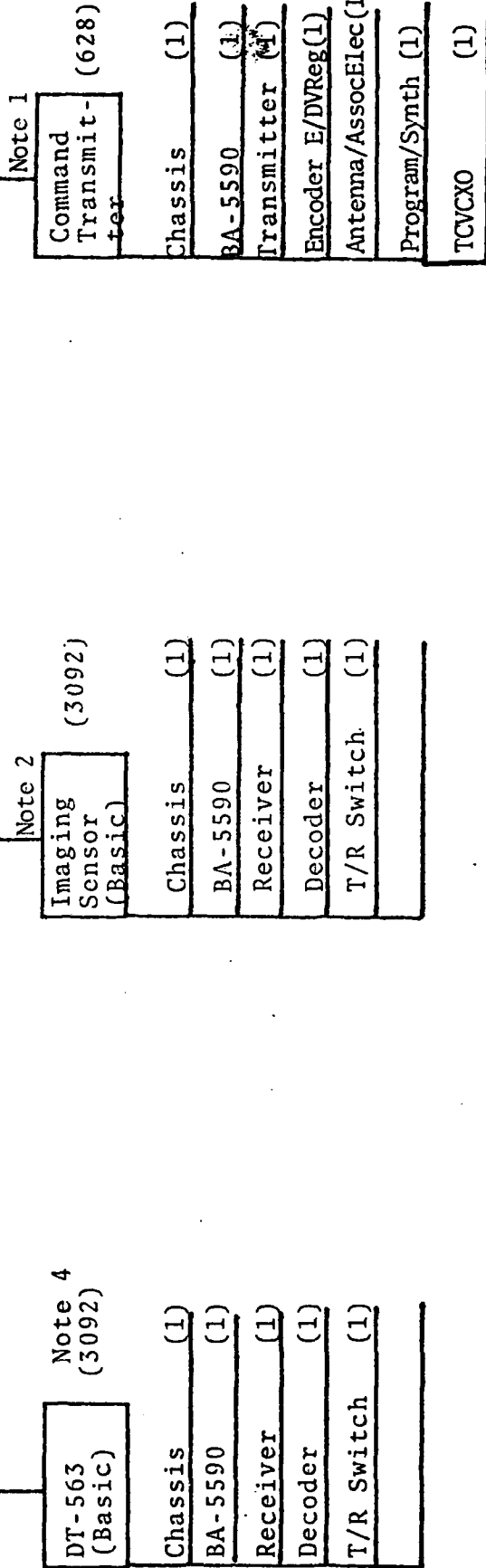

Figure A-2. Alt. 2 Add on Component Breakdown

Note 1: Command Transmitter (CT) and repeater requires a development effort. CT does not exist in Basic REMBASS.

Note 2: Imaging Sensor presently is in advanced development.

Note 3: All numbers in parentheses are the additional quantities of equipment/hardware required to add command-ability to Basic REMBASS based upon a 24 division force structure.

Commandable
REMBASS
Alternative 3

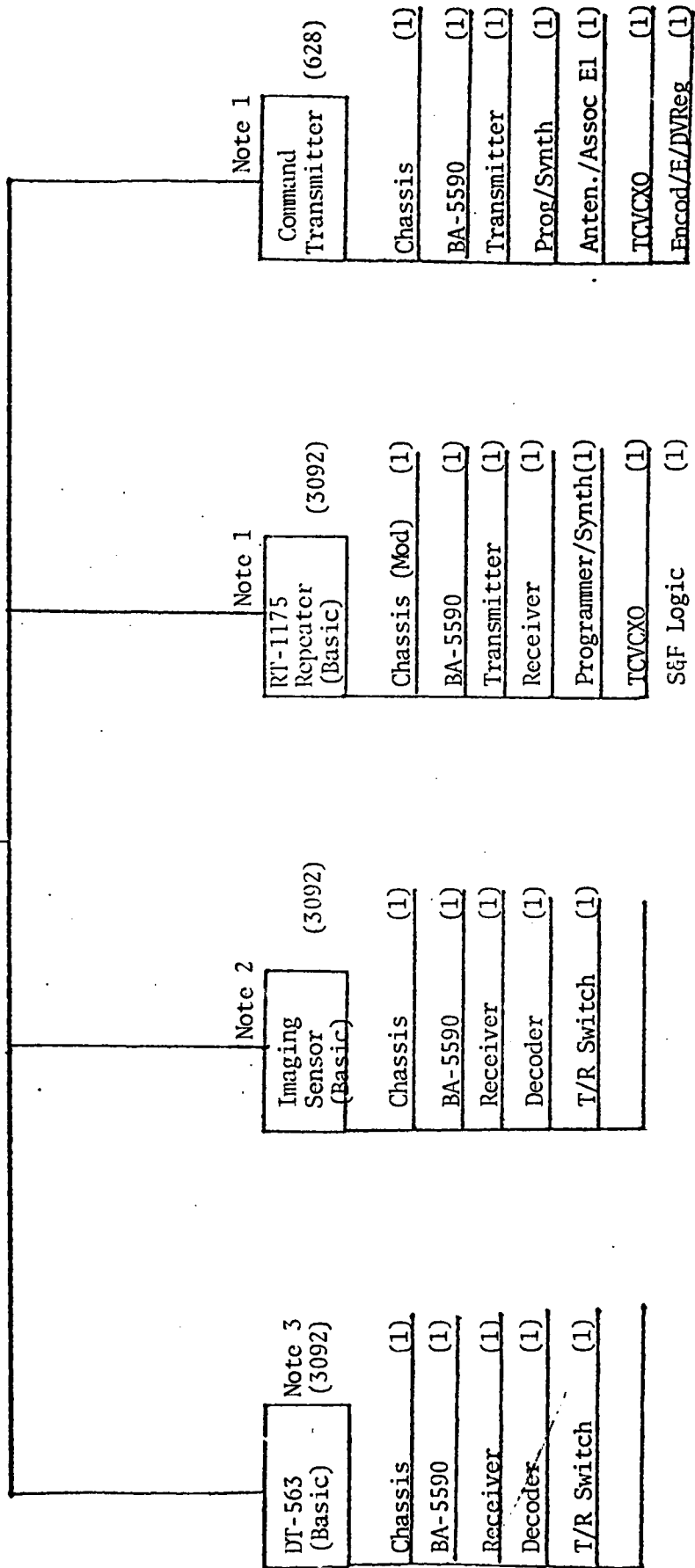

Figure A-3. Alt. 3 Add on Component Breakdown

Note 1: Command Transmitter (CT) and repeater requires a development effort. CT does not exist in Basic REMBASS.

Note 2: Imaging sensor presently in advanced development.

Note 3: All numbers in parentheses are additional quantities of equipments/hardware items required to add commandability to Basic REMBASS based upon a 24 division force structure.

Commandable
REMBASS
Alternative 4

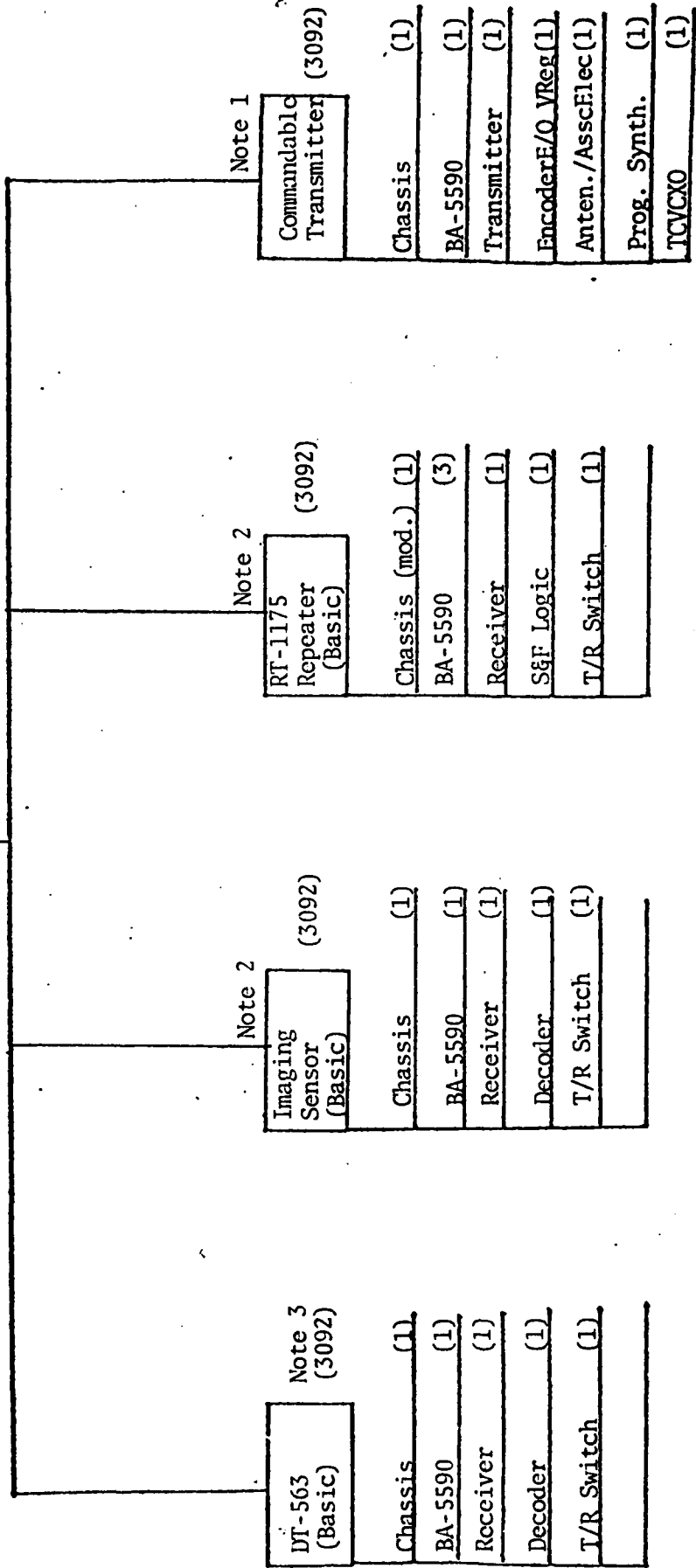

Figure A-4. Alt. 4 Add on Component Breakdown

Note 1: Command Transmitter (CT) requires a development effort. CT not incl. in Basic REMBASS.

Note 2: Imaging Sensor is in adv. development.

Note 3: RT-1175 (repeater) requires chassis mod. (PIP), adding logic CKTS, and assoc. elec.

Note 4: All nos. in parentheses are the add'l. quantities of equip./hardware items req. to add commandability to Basic REMBASS based upon a 24 division force structure.

Commandable
REMBASS
Alternative 5

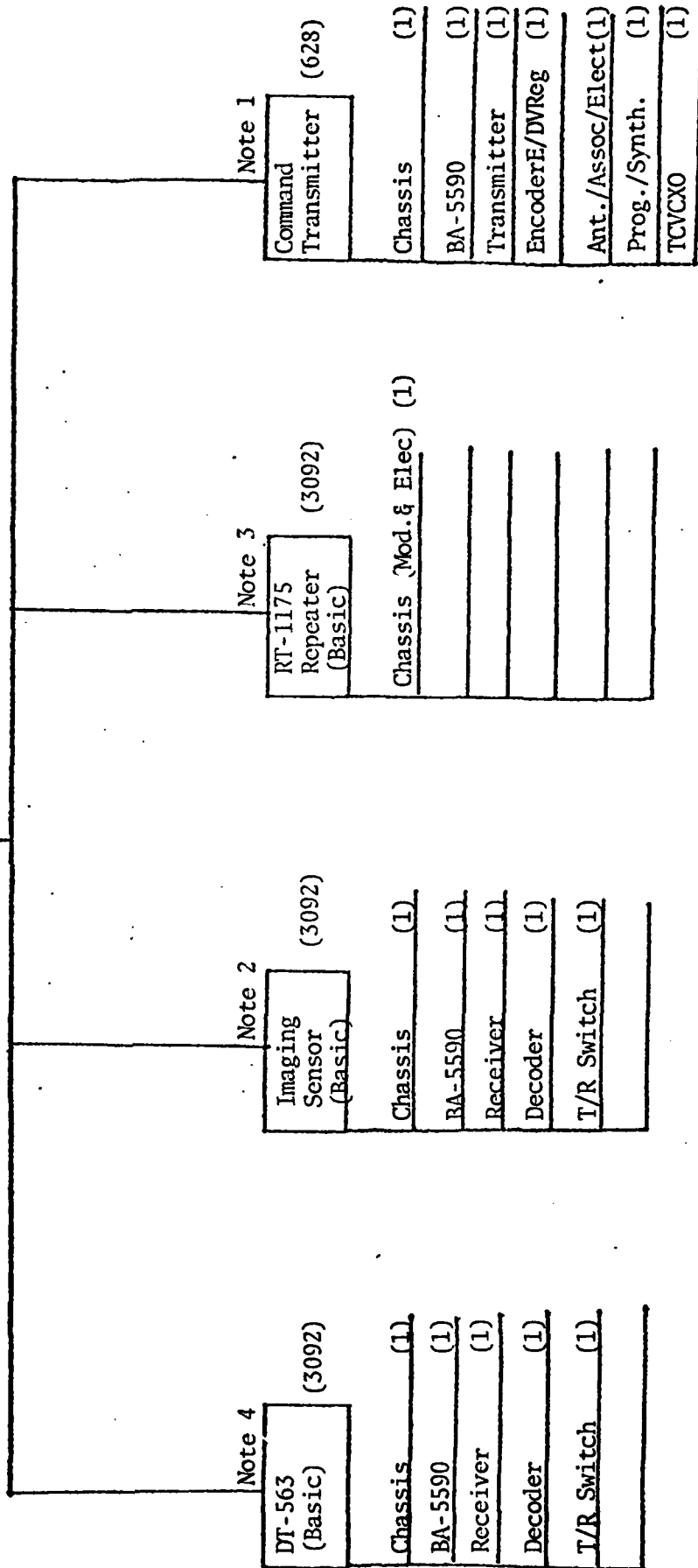

Figure A-5. Alt. 5 Add on Component Breakdown.

Note 1: Command Transmitter (CT)

requires a development effort. CT does not exist in Basic REMBASS.

Note 2: Imaging Sensor presently is in advanced development.

Note 3: All numbers in parentheses are the additional quantities of equipment/hardware required to add command-ability to Basic REMBASS based upon a 24 division force structure.

Commandable
REMBASS
Alternative 6

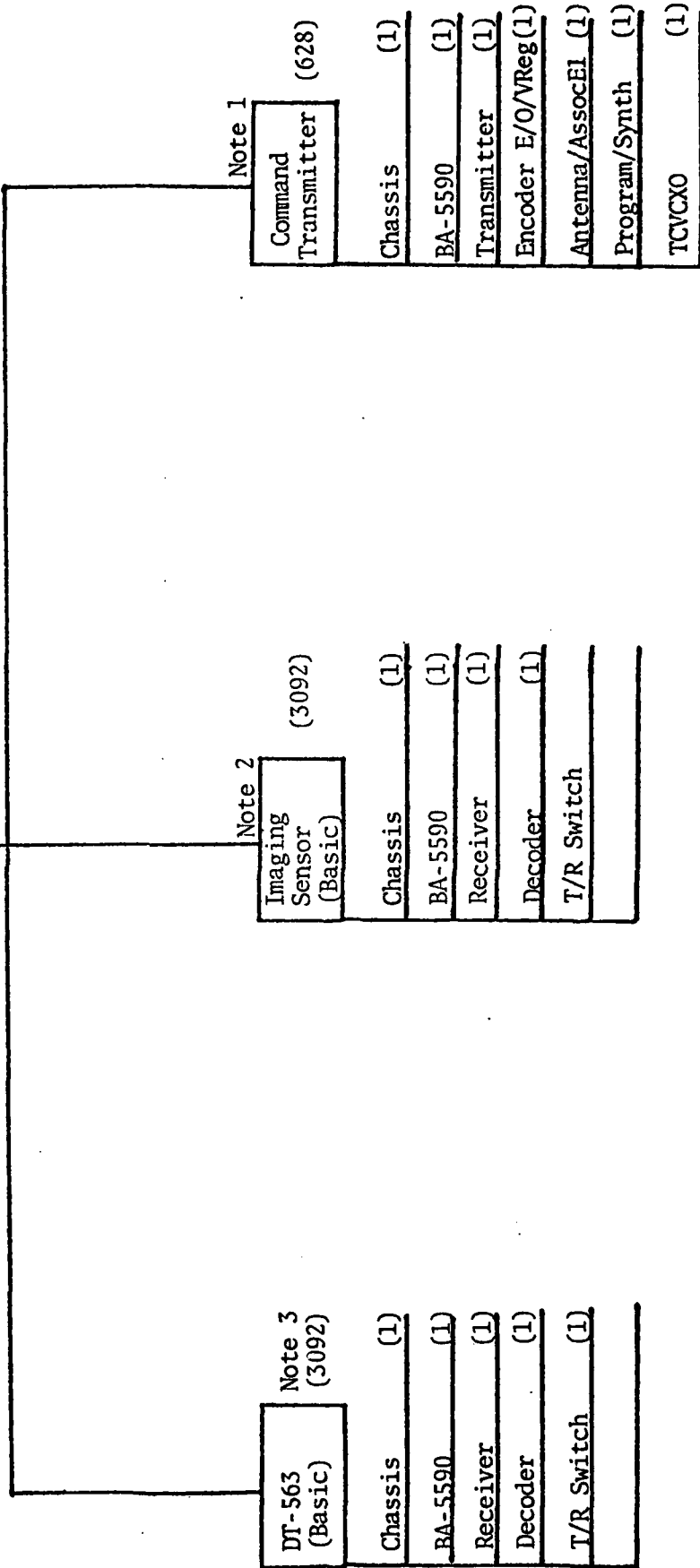

Figure A-6. Alt. 6 Add on Component Breakdown.

APPENDIX B
RELIABILITY COMPUTATIONS

B.1.1 GENERAL

Reliability computations were completed on all alternatives considered using Paragraph 3.6.1 of RBS-001 as the basis. The specified reliability of the system is .80 probability of success for a mission time of 168 hours. The Basic REMBASS reliability model (Figure B.1.1) is used as a starting point, making necessary changes to reflect the addition of commandability. In the model any two of three sensors must operate without failure for 168 hours. The highest sensor failure rate was used for all calculations. All equipment in series with the sensors must operate 168 hours without failure. Each alternative reliability configuration is discussed in the following paragraphs. Failure rate assessment of each item of equipment involved is provided in Tables B.1.1 thru B.1.11.

B.1.1.1 Reliability (Alternative 1). The reliability in Alternative 1 as calculated falls well above the REMBASS specification. Figure B.1.2 is the reliability prediction model used for this alternative.

B.1.1.2 Reliability (Alternative 2). The predicted reliability for Alternative 2 is .776 when both systems are calculated together (command and data link). This calculation is provided in Figure B.1.3. If these two links were calculated separately the predicted reliability of each link

is well above the .80 reliability set forth in the REMBASS specifications. For this reason, the .776 reliability while considered in evaluation of the alternatives as being significant, was not considered dominant because of system configuration. If Alternative 2 should ultimately be the choice system, the reliability should be further explored.

B.1.1.3 Reliability (Alternative 3). The reliability prediction of .813 in Alternative 3 is above the REMBASS specification requirement of .80. The reliability model for Alternative 3 is shown in Figure B.1.4.

B.1.1.4 Reliability (Alternative 4). The reliability prediction for this alternative is .818 which is well above the .80 REMBASS specification requirement. Figure B.1.5 shows the reliability prediction model used in this alternative.

B.1.1.5 Reliability (Alternative 5). The reliability prediction for this alternative is .823, again well above the REMBASS specification requirement. Figure B.1.6 shows the reliability prediction model used in this alternative.

B.1.1.6 Reliability (Alternative 6). The reliability prediction for this model is .823, well above the REMBASS specification requirement (.80), and is provided in Figure B.1.7.

B.1.2 CONCLUSION

The addition of commandability has relatively little affect on the predicted reliability of the Basic REMBASS.

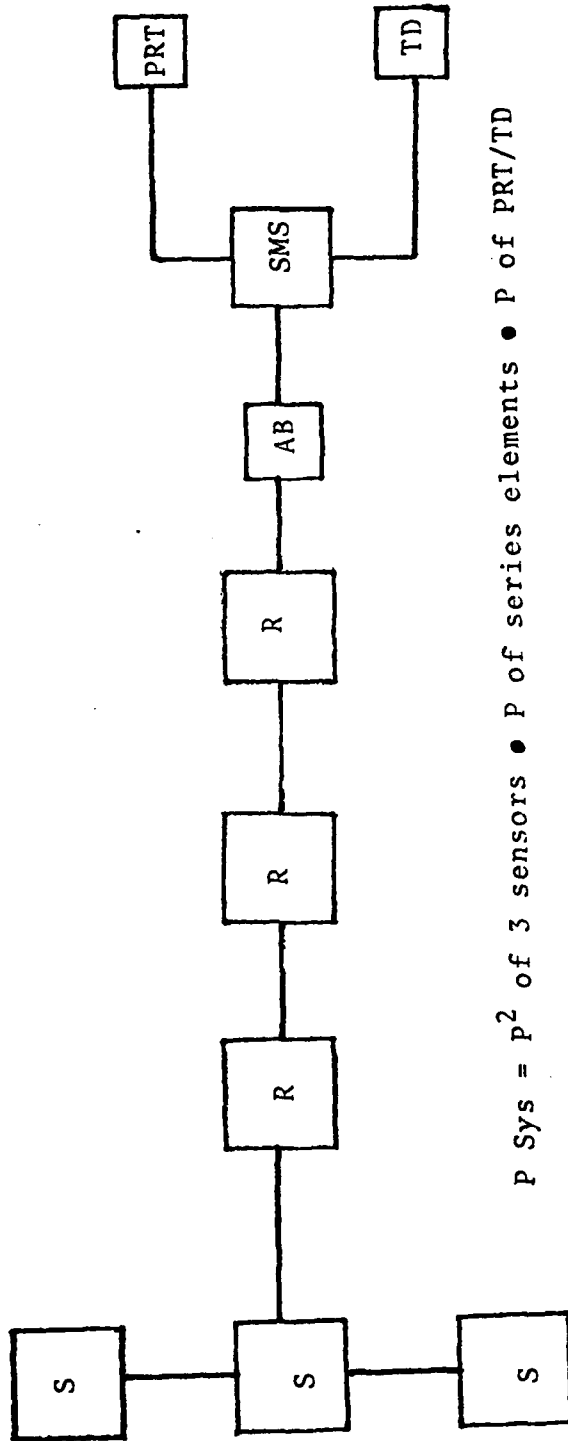

$P_{\text{Sys}} = p^2$ of 3 sensors • P of series elements • P of PRT/TD

FIGURE B.1.1. BASIC REMBASS RELIABILITY MODEL

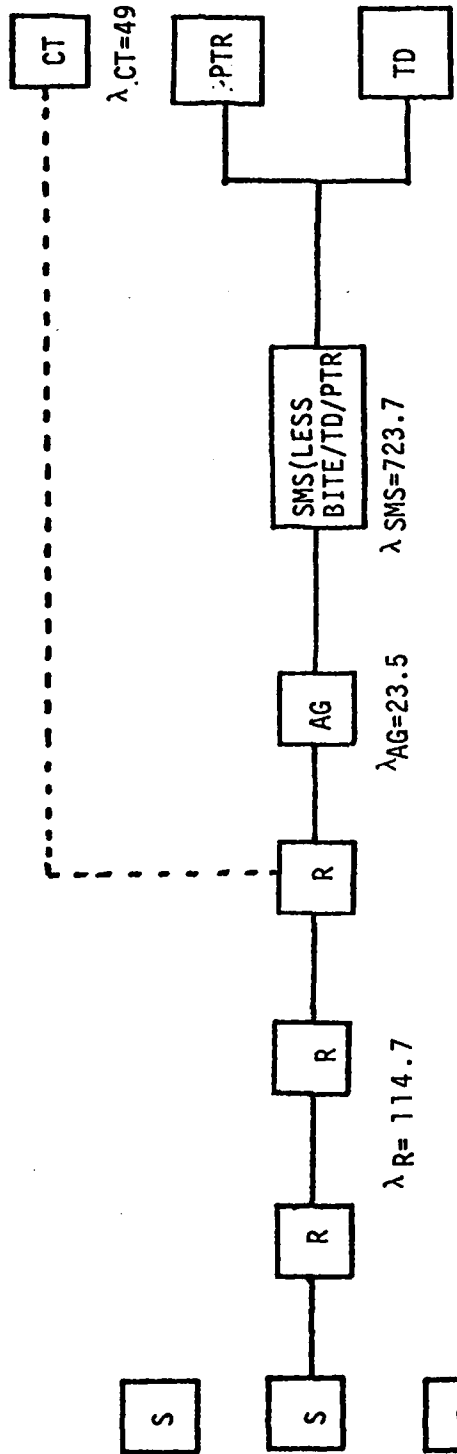

$$\begin{aligned}
 P_{syst} &= P_2 \text{ of 3 sensors} \cdot P \text{ series elements} \cdot P \text{ PTR/TD} \\
 &= [-2 \cdot e^{-3\lambda_S t} + 3 \cdot e^{-2\lambda_S t}] \cdot [e^{-(3\lambda_R + \lambda_{AG} + \lambda_{SMS} + \lambda_{CT}) t}] \cdot [e^{-\lambda_{PTR} t} + e^{-\lambda_{TD} t} - (e^{-\lambda_{PTR} t} + e^{-\lambda_{TD} t}) t] \\
 &= [.998688] \cdot [.32566] \cdot [.998586] \\
 &= .823
 \end{aligned}$$

- S=Sensor
- R=Repeater
- AG=Antenna Group
- SMS=Sensor Monitoring Set
- CT=Command Transmitter
- TD=Temporary Display
- PTR=Printer

Required Mission Time = 168 hours
 Failure Rate = (Given in failures 10^6 hours)

FIGURE B.1.2. REMBASS ALTERNATIVE 1 RELIABILITY PREDICTION

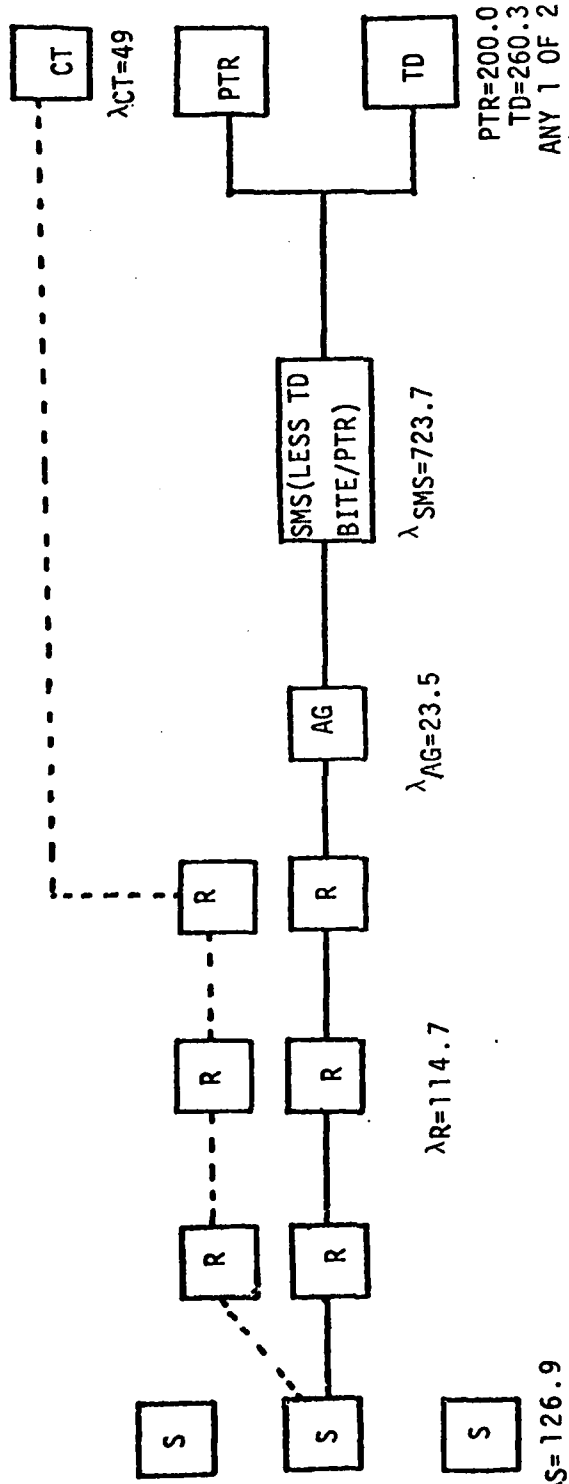

$$P_{syst} = P_2 \text{ of } 3 \text{ sensors} \cdot P \text{ series elements} \cdot P \text{ PTR/TD}$$

$$= [-2 \cdot e^{-3\lambda_s t} + 3 \cdot e^{-2\lambda_s t}] \cdot [e^{-(3\lambda_R + \lambda_{AG} + \lambda_{SMS})t} \cdot e^{-(3\lambda_R + \lambda_{CT})t}] \cdot [e^{-\lambda_{PTR}t} \cdot e^{-\lambda_{TD}t} - e^{-(\lambda_{PTR} + \lambda_{TD})t}]$$

$$= [.99868] \cdot [.77928] \cdot [.998586]$$

$$= .776$$

Required Mission Time = t = 168 hours
 Failure Rate = (Given in failures 10⁶ hours)

- S=Sensor
- R=Repeater
- AG=Antenna Group
- SMS=Sensor Monitoring Set
- CT=Command Transmitter
- TD=Temporary Display
- PTR= Printer

FIGURE B.1.3. REMBASS ALTERNATIVE 2 RELIABILITY PREDICTION

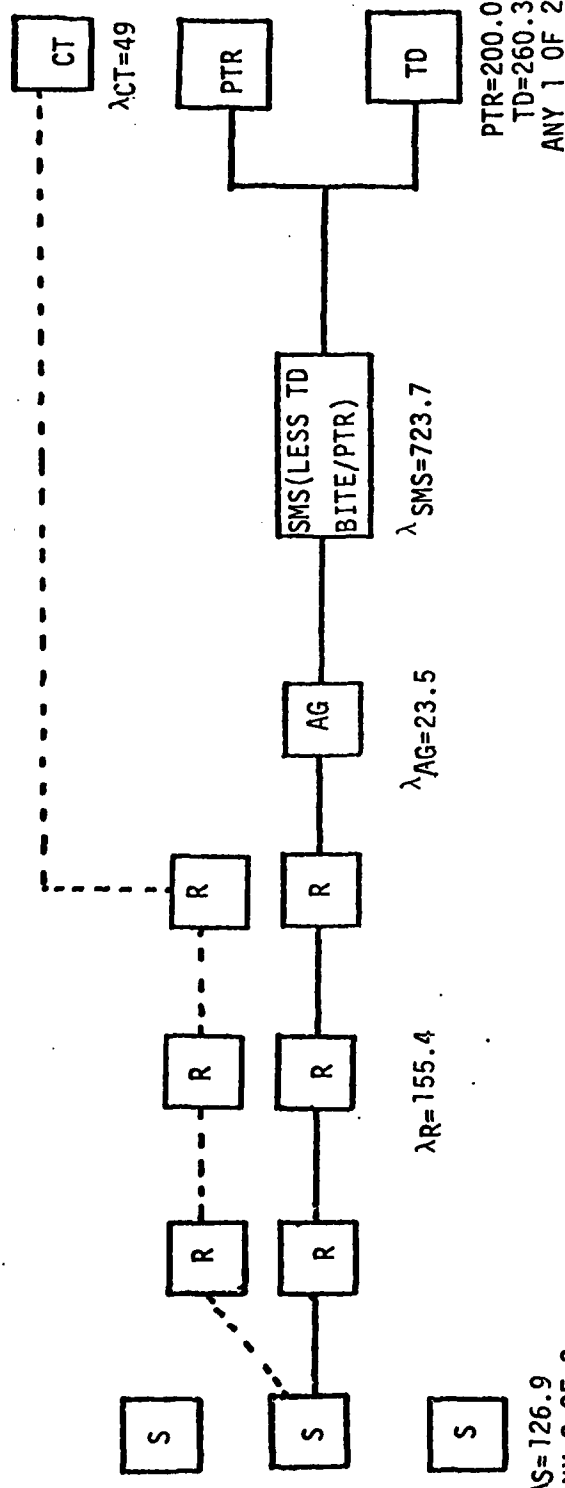

$$P_{syst} = P_2 \text{ of } 3 \text{ sensors} \cdot P \text{ series elements} \cdot P \text{ PTR/TD}$$

$$= [-2 \cdot e^{-3\lambda_S t} + 3 \cdot e^{-2\lambda_S t}] \cdot [e^{-(3\lambda_R + \lambda_{AG} + \lambda_{SMS})t} \cdot e^{-(3\lambda_R + \lambda_{CT})t}] \cdot [e^{-\lambda_{PTR} t} + e^{-\lambda_{TD} t} - (e^{-\lambda_{PTR} t} + \lambda_{TD})t}]$$

$$= [.99868] \cdot [.81531] \cdot [.998586]$$

$$= .813$$

Required Mission Time = $t = 168$ hours.
 Failure Rate = (Given in failures 10^6 hours)

- S=Sensor
- R=Repeater
- AG=Antenna Group
- SMS=Sensor Monitoring Set
- CT=Command Transmitter
- TD=Temporary Display
- PTR= Printer

FIGURE B.1.4. REMBASS ALTERNATIVE 3 RELIABILITY PREDICTION

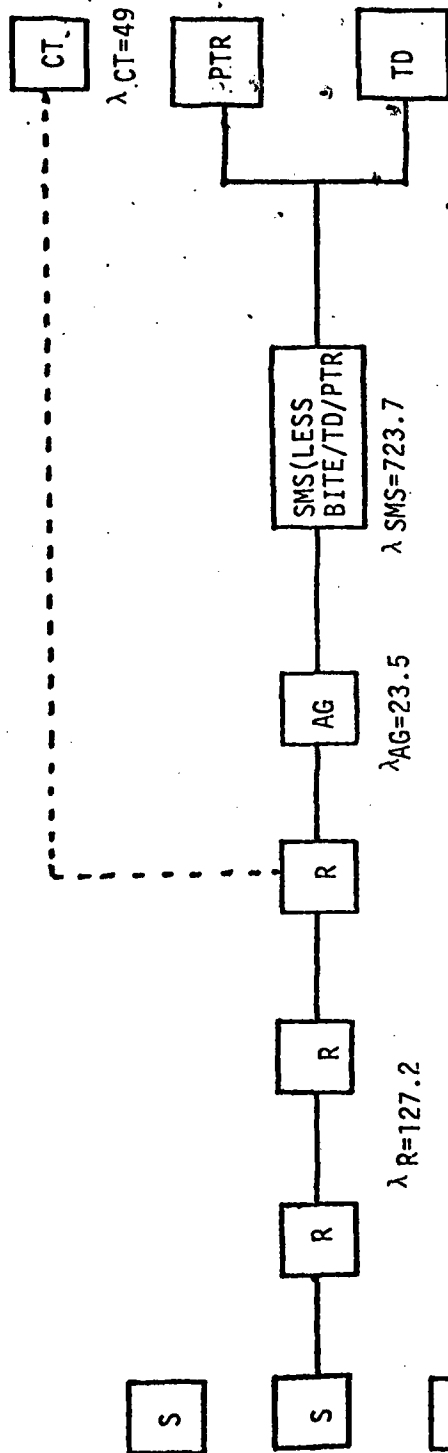

$\lambda_{PTR} = 200.0$
 $\lambda_{TD} = 260.3$
 ANY 1 OF 2

$\lambda_S = 126.9$
 ANY 2 OF 3

Psyst = P2 of 3 sensors · P series elements · P PTR/TD

$$\begin{aligned}
 &= [-2 \cdot e^{-3\lambda_S t} + 3 \cdot e^{-2\lambda_S t}] \cdot [e^{-(3\lambda_R + \lambda_{AG} + \lambda_{SMS} + \lambda_{CT}) t}] \cdot [e^{-\lambda_{PTR} t} + e^{-\lambda_{TD} t} - (\lambda_{PTR} + \lambda_{TD}) t}] \\
 &= [.99868] \cdot [.820476] \cdot [.998586] \\
 &= .818
 \end{aligned}$$

- S=Sensor
- R=Repeater
- AG=Antenna Group
- SMS=Sensor Monitoring Set
- CT=Command Transmitter
- TD=Temporary Display
- PTR=Printer

Required Mission Time = t = 168 hours
 Failure Rate = (Given in failures 10⁶ hours)

FIGURE B.1.5. REMBASS ALTERNATIVE 4 RELIABILITY PREDICTION

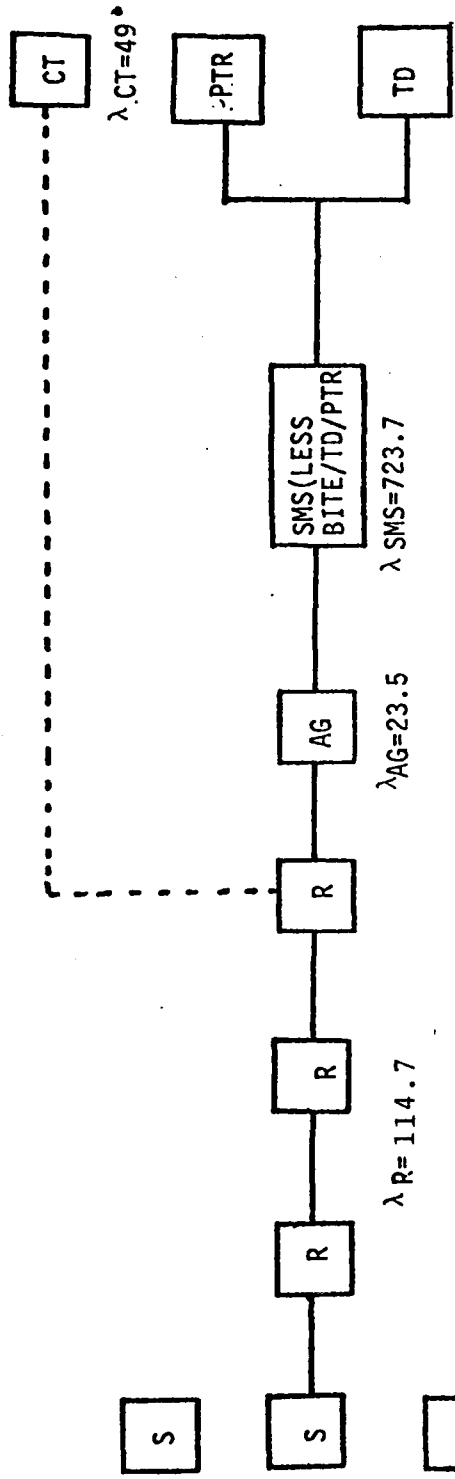

$\lambda_{PTR} = 200.0$
 $\lambda_{TD} = 260.3$
 ANY 1 OF 2

$\lambda_S = 126.9$
 ANY 2 OF 3

$\lambda_R = 114.7$
 $\lambda_{AG} = 23.5$
 $\lambda_{SMS} = 723.7$

$$\begin{aligned}
 P_{syst} &= P_2 \text{ of 3 sensors} \cdot P \text{ series elements} \cdot P \text{ PTR/TD} \\
 &= [-2 \cdot e^{-3\lambda_S t} + 3 \cdot e^{-2\lambda_S t}] \cdot [e^{-(3\lambda_R + \lambda_{AG} + \lambda_{SMS} + \lambda_{CT})t}] \cdot [e^{-\lambda_{PTR} t} + e^{-\lambda_{TD} t} - e^{-(\lambda_{PTR} + \lambda_{TD})t}] \\
 &= [.99868] \cdot [.82566] \cdot [.998586] \\
 &= .823
 \end{aligned}$$

- S=Sensor
- R=Repeater
- AG=Antenna Group
- SMS=Sensor Monitoring Set
- CT=Command Transmitter
- TD=Temporary Display
- PTR=Printer

Required Mission Time = $t = 168$ hours
 Failure Rate = (Given in failures 10^6 hours)

FIGURE B.1.6. REMBASS ALTERNATIVE 5 RELIABILITY PREDICTION

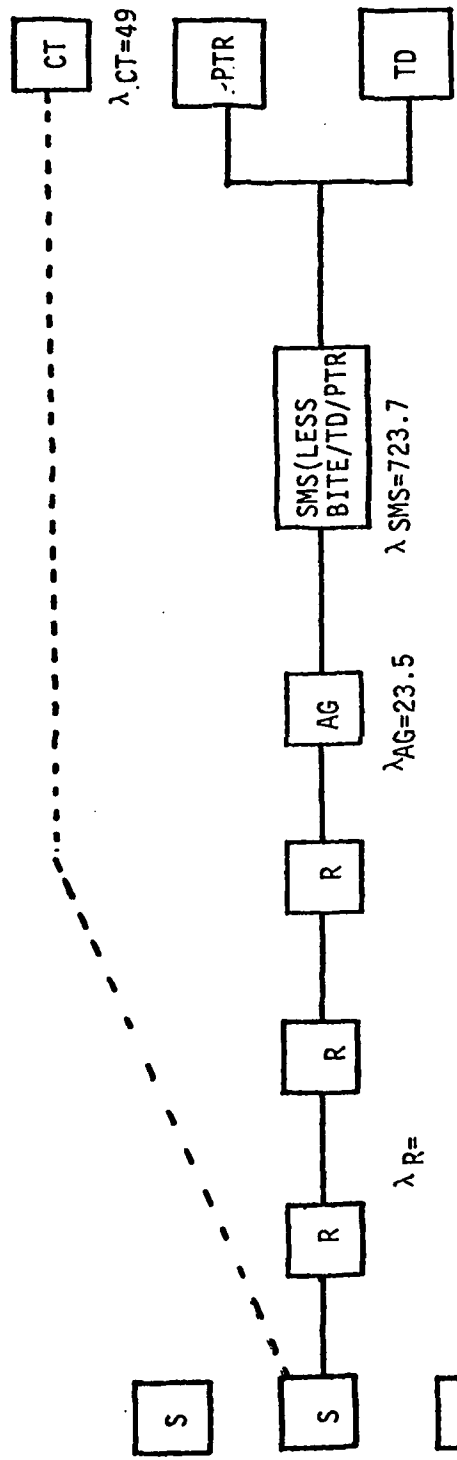

$\lambda_S =$
 ANY 2 OF 3

$P_{syst} = P_2 \text{ of } 3 \text{ sensors} \cdot P \text{ series elements} \cdot P \text{ PTR/TD}$

$$= [-2 \cdot e^{-3\lambda_S t} + 3 \cdot e^{-2\lambda_S t}] \cdot [e^{-(3\lambda_R + \lambda_{AG} + \lambda_{SMS} + \lambda_{CT})t}] \cdot [e^{-\lambda_{PTR}t} + e^{-\lambda_{TD}t} - e^{-(\lambda_{PTR} + \lambda_{TD})t}]$$

$$= [.998683] \cdot [.82566] \cdot [.998586]$$

$$= .823$$

Required Mission Time = $t = 16$ hours
 Failure Rate = (Given in failures 10^6 hours)

- S=Sensor
- R=Repeater
- AG=Antenna Group
- SMS=Sensor Monitoring Set
- CT=Command Transmitter
- TD=Temporary Display
- PTR=Printer

FIGURE B.1.7. REMBASS ALTERNATIVE 6 RELIABILITY PREDICTION

TABLE B.1.1. FAILURE RATE ASSESSMENT DT-561 SENSOR

| MODULE NAME | DRAWING NUMBER | FAILURE RATE (FX10E-6HRS) | FAILURE RATE SOURCE |
|-------------------|-----------------|---------------------------|---------------------|
| PROGRAMMER | RBS56240-501 | 31.2192 | (U) RCA PROPOSAL |
| TRANSMITTER | RBS57020-502 | 4.1488 | 942117B VOL II |
| REGULATOR | RBS57030-502 | 3.0736 | (DESCRIPTION OF |
| ENABLE/DISABLE | RBS57040-502 | 5.8106 | OPTIMUM SYSTEM) |
| ENCODER | RBS56120-501 | 11.5986 | REMBASS DATED |
| MAG SENSOR ELEC | RBS56170-501 | 30.9398 | 28 MARCH 1977 (C) |
| BATTERY | BA-5590/U | NOTE | " |
| MAGNETOMETER | RBS56110-501 | 10. | " |
| ANT. ASS'Y | RBS56230-501 | 1. | " |
| SWITCH, TEST | 51MP30-01-3-03N | 1.4 | " |
| SWITCH, DURATION | 50MP45-01-2-04N | 1.4 | " |
| SWITCH, RECOVERY | 50MP36-01-2-10N | 1.4 | " |
| SWITCH, ANTI-TAMP | 17AC1-T | 1.4 | " |
| SWITCH, MOTION | 3022-2-000 | 1.4 | " |
| RECEIVER | RBS120020-501 | 2.6788 | " |
| * DECODER | NONE | 11.5986 | " |
| * DIPLEXER | RBS117530-501 | 1.3944 | " |

* Estimate -- Used encoder failure rate since both modules do equal but opposite functions.

Total Failure Rate = 120.5 (FX10E-6HRS)

Mean Time Between Failures 8299 Hrs.

TABLE B.1.2. FAILURE RATE ASSESSMENT DT-562 SENSOR

| MODULE NAME | DRAWING NUMBER | FAILURE RATE (FX10E-6HRS) | FAILURE RATE SOURCE |
|-------------------|-----------------|------------------------------|------------------------|
| PROGRAMMER | RBS56240-501 | 31.2192 | RCA PROPOSAL |
| TRANSMITTER | RBS57020-502 | 4.1488 | 942117B VOL II |
| REGULATOR | RBS57030-502 | 3.0736 | (DESCRIPTION OF |
| ENABLE/DISABLE | RBS57040-502 | 5.8106 | OPTIMUM SYSTEM) |
| CLASS, SEIS/ACOU | RBS56270-501 | 20.7668 | REMBASS DATED |
| BATTERY | 8A-5590/U | NOTE | 28 MARCH 1977 |
| GEOPHONE ASS'Y | RBS56210-501 | 10. | " |
| MICROPHONE/DIPLEX | RBS56220-501 | 10. | " |
| ANT. ASS'Y | RBS56230-501 | 1. | " |
| SWITCH, TEST | 51MP30-01-3-03N | 1.4 | " |
| SWITCH, DURATION | 50MP45-01-2-04N | 1.4 | " |
| SWITCH, RECOVERY | 50MP36-01-2-10N | 1.4 | " |
| SWITCH, ANTI-TAMP | 17AC1-T | 1.4 | " |
| SWITCH, MOTION | 3022-2-000 | 1.4 | " |
| RECEIVER | RBS120020-501 | 2.6788 | " |
| DIPLEXER | RBS117530-501 | 1.3944 | " |
| * DECODER | NONE | 11.5986 | " |

Total Failure Rate = 108.7
 Mean time before failure = 9,200 hrs.

* Estimate-- used encoder failure rate
 since both modules do
 equal but opposite functions.

TABLE B.1.1.3. FAILURE RATE ASSESSMENT DT-563 SENSOR

| MODULE NAME | DRAWING NUMBER | FAILURE RATE (FX10E-6HRS) | FAILURE RATE SOURCE |
|-------------------|-----------------|------------------------------|------------------------|
| PROGRAMMER | RBS56240-501 | 31.2192 | (U) RCA PROPOSAL |
| TRANSMITTER | RBS57020-502 | 4.1488 | VOL II (DESCRIPTION |
| REGULATOR | RBS57030-502 | 3.0736 | OF OPTIMUM SYSTEM) |
| ENABLE/DISABLE | RBS57040-502 | 5.8106 | REMBASS DATED |
| ENCODER | RBS56120-501 | 11.5986 | 28 MARCH 1977 (C) |
| ANAL SENSOR ELEC | RBS56370-501 | 10.4184 | " |
| BATTERY | BA-5590/U | NOTE | " |
| GEOPHONE ASS'Y | RBS56210-501 | 10. | " |
| MICROPHONE/DIPLEX | RBS56220-501 | 10. | " |
| ANT. ASS'Y | RBS56230-501 | 1. | " |
| SWITCH, TEST | 51MP30-01-3-03N | 1.4 | " |
| SWITCH, DURATION | 50MP45-01-2-04N | 1.4 | " |
| SWITCH, RECOVERY | 50MP36-01-2-10N | 1.4 | " |
| SWITCH, ANTI-TAMP | 17AC1-T | 1.4 | " |
| SWITCH, MOTION | 3022-2-000 | 1.4 | " |
| RECEIVER | RBS120020-501 | 2.6788 | " |
| DIPLEXER | RBS117530-501 | 1.3944 | " |
| * DECODER | NONE | 11.5886 | " |

* Estimate -- used encoder failure rate since both module perform equal but opposite functions.

Total failure rate = 110.0
Mean Time between Failure = 9091 Hrs.

TABLE B.1.4. FAILURE RATE ASSESSMENT DT-565 SENSOR

| MODULE NAME | DRAWING NUMBER | FAILURE RATE (FX10E-6HRS) | FAILURE RATE SOURCE |
|-------------------|-----------------|------------------------------|------------------------|
| PROGRAMMER | RBS56240-501 | 31.2192 | (U) RCA PROPOSAL |
| TRANSMITTER | RBS57020-502 | 4.1488 | 942117B VOL II |
| REGULATOR | RBS57030-502 | 3.0736 | (DESCRIPTION OF |
| ENABLE/DISABLE | RBS57040-502 | 5.8106 | OPTIMUM SYSTEM) |
| ENCODER | RBS56120-501 | 11.5986 | REMBASS DATED |
| I.R. SENSOR ELEC. | RBS56570-501 | 27.4068 | 28 MARCH 1977 (C) |
| BATTERY | BA-5590/U | NOTE | " |
| IR DETECTOR HEAD | RBS56510-501 | 10. | " |
| IR CABLE ASS'Y | RBS56515-501 | 10. | " |
| ANT. ASS'Y | RBS56230-501 | 1. | " |
| SWITCH, TEST | 51MP30-01-3-03N | 1.4 | " |
| SWITCH, DURATION | 50MP45-01-2-04N | 1.4 | " |
| SWITCH, RECOVERY | 50MP36-01-2-10N | 1.4 | " |
| SWITCH, ANTI-TAMP | 17AC1-T | 1.4 | " |
| SWITCH, MOTION | 3022-2-000 | 1.4 | " |
| RECEIVER | RBS120020-501 | 2.6788 | " |
| DIPLEXER | RBS117530-501 | 1.3944 | " |
| * DECODER | NONE | 11.5986 | " |

Total Failure Rate = 126.9

Mean Time between Failure = 7880 Hrs.

* Estimate -- used encoder failure rate since both modules perform equal but opposite functions.

TABLE B.1.5. FAILURE RATE ASSESSMENT DT-573 SENSOR

| MODULE NAME | DRAWING NUMBER | FAILURE RATE (FX10E-6HRS) | FAILURE RATE SOURCE |
|-------------------|-----------------|------------------------------|------------------------|
| PROGRAMMER | RBS56240-501 | 31.2192 | (U) RCA PROPOSAL |
| TRANSMITTER | RBS57020-502 | 4.1488 | 942117B VOL II |
| REGULATOR | RBS57030-502 | 3.0736 | (DESCRIPTION OF |
| ENABLE/DISABLE | RBS57040-502 | 5.8106 | OPTIMUM SYSTEM) |
| ENCODER | RBS56120-501 | 11.5986 | REMBASS DATED |
| STRAIN WIRE ELEC | RBS57370-501 | 33.4404 | 28 MARCH 1977 |
| BATTERY | BA-5590/U | NOTE | " |
| STRAIN WIRE ASS'Y | RBS57310-501 | 10. | " |
| ANT. ASS'Y | RBS56230-501 | 1. | " |
| SWITCH, TEST | 51MP30-01-3-03N | 1.4 | " |
| SWITCH, DURATION | 50MP45-01-2-04N | 1.4 | " |
| SWITCH, RECOVERY | 50MP36-01-2-10N | 1.4 | " |
| SWITCH, ANTI-TAMP | 17AC1-T | 1.4 | " |
| SWITCH, MOTION | 3022-2-000 | 1.4 | " |
| RECEIVER | RBS120020-501 | 2.6788 | " |
| DIPLEXER | RBS117530-501 | 1.3944 | " |
| * DECODER | NONE | 11.5986 | " |

Total Failure Rate= 123.0
 Mean Time between Failure = 8130 Hrs.

* Estimate -- used encoder failure rate since both modules perform equal but opposite functions.

TABLE B.1.6

SUMMARY FAILURE RATE ASSESSMENT, SENSOR MONITOR SET

| MODULE OR ASSEMBLY | FAILURE RATE SOURCE | FAILURE RATE f/10 ⁶ HOURS |
|---|---------------------------------|--------------------------------------|
| Receiver/Synth Module (2) | (U) RCA PROPOSAL | 149.686 |
| Detect/Decode/Patch/Calc Logic Board | 942117B VOL II | 405.223 |
| Clock/BITE/Pwr. Control/Display Logic Board | (DESCRIPTION OF OPTIMUM SYSTEM) | 62.807 |
| Display Driver Board | REMBASS DATED | 179.237 |
| Display Board | 28 MARCH 1977 | 50.005 |
| Front Panel | | 68.200 |
| Calc/Patch Keyboard | | 61.700 |
| Case | | 3.450 |
| Wire and Connector Assembly | | 3.000 |
| Thermal Printer Module | | 200.000 |
| AC/DC Power Supply Module | | 11.961 |
| Battery Pack | | NOTE |

NOTE: Battery is not assigned a failure rate probability of success because it can be replaced in 5 minutes.

Total Failure Rate
= λ_T = 1195.269

All Modules,
MTBF = θ_T = 834 hrs.
All Functions

BITE, Temp Display and Printer

| | Failure Rate f/10 ⁶ hours |
|-------------------------|---|
| BITE | 11.100 |
| Temp. Display | 260.293 |
| Printer | 200.000 |
| BITE, T.D., Ptr. | $\lambda_{BITE/TD/PTR} = 471.393$ |
| Complete SMS | $\lambda_T = 1195.269$ |
| Less BITE, TD,Ptr. | $\lambda_{BITE/TD/PTR} = -471.393$ |
| SMS less BITE, TD, Ptr. | $\lambda_{SMS} = 723.876$ MTBF - 1381 hours |

TABLE B.1.7

* SUMMARY FAILURE RATE ASSESSMENT
PORTABLE COMMAND TRANSMITTER

| <u>MODULE/ASSEMBLY</u> | <u>DRAWING #</u> | <u>FAILURE RATE F/10⁶ Hours</u> | <u>FAILURE RATE SOURCE</u> |
|---------------------------|------------------|--|--|
| Transmitter | RBS-57020-520 | 4.1488 | (C) RCA Proposal 942117B Vol. II (Description of Optimum System) REMBASS dated 28 March 1977. (C) |
| Programmer | RBS-56240-501 | 31.2192 | " |
| Regulator | RBS-57030-502 | 3.0736 | " |
| Encoder | RBS-56120-501 | 11.5986 | " |
| Ant, Assy. | RBS-56230-50 | 1.0000 | " |
| Wire & Connector Assy. | --- | 1.0000 | " |

* Summary Failure Rate for the CT is based on using modules developed for Basic REMBASS and assessed in Vol. II RCA (Module Failure Rate Assessment).

Total Failure Rate = 49
(FX10E-6HRS)

Mean Time Between Failures = 20,408 hours

TABLE B.1.8
FAILURE RATE ASSESSMENT, RT-1175 REPEATER

| MODULE NAME | DRAWING NUMBER | FAILURE RATE (FX10E-6HRS) | FAILURE RATE SOURCE |
|-------------------|----------------|------------------------------|------------------------|
| PROGRAMMER (2 EA) | RBS56240-501 | 62.4384 | (U) RCA PROPOSAL |
| TRANSMITTER | RBS57020-502 | 4.1488 | 942117B VOL II |
| REGULATOR | RBS57030-502 | 3.0736 | (DESCRIPTION OF |
| ENABLE/DISABLE | RBS57040-502 | 5.8106 | OPTIMUM SYSTEM) |
| RECEIVER | RBS120020-501 | 2.6788 | REMBASS DATED |
| DIPLEXER (2EA) | RBS117530-501 | 2.7888 | 28 MARCH 1977. |
| STORE & FWD LOGIC | RBS120040-501 | 23.9848 | " |
| SWITCHES | SEVEN EACH | 9.8000 | " |
| BATTERY 96EA) | BA5590/U | NOTE 1 | " |

1. Battery not included in probability rate because it is replaceable w/in 5 minutes.

Total Failure Rate = 114.7
FX10E-6HRS.

Mean Time between Failures = 8.700 Hrs.

TABLE B.1.9
FAILURE RATE ASSESSMENT, ALTERNATIVE 3 REPEATER

| MODULE NAME | DRAWING NUMBER | FAILURE RATE (FX10E-6HRS) | FAILURE RATE SOURCE |
|--------------------------|----------------|------------------------------|------------------------|
| PROGRAMMER (2 EA) | RBS56240-501 | 62.4384 | (U) RCA PROPOSAL |
| TRANSMITTER (2 EA) | RBS57020-502 | 8.2976 | 942117B VOL II |
| REGULATOR | RBS57030-502 | 3.0736 | (DESCRIPTION OF |
| ENABLE/DISABLE | RBS57040-502 | 5.8106 | OPTIMUM SYSTEM) |
| RECEIVER (2EA) | RBS120020-501 | 5.3576 | REMBASS DATED |
| DIPLEXER (2 EA) | RBS117530-501 | 2.7888 | 28 MARCH 1977 (C) |
| STORE & FWD LOGIC (2 EA) | RBS120040-501 | 47.9696 | " |
| SWITCHES | 14 EACH | 19.6000 | " |
| BATTERY (12 EA) | BA5590/U | NOTE 1 | " |

NOTE 1 -- Battery not included because
batteries are replaceable w/in
5 minutes and not classified
as failure.

Total Failure Rate = 155.4
FX10E-6HRS.

Mean Time between Failures = 6,435 Hrs.

TABLE B.1.10
FAILURE RATE ASSESSMENT, ALTERNATIVE 4 REPEATER

| MODULE NAME | DRAWING NUMBER | FAILURE RATE (FX10E-6HRS) | FAILURE RATE SOURCE |
|-------------------|----------------|------------------------------|------------------------|
| PROGRAMMER (2 EA) | RBS56240-501 | 62.4384 | (U) RCA PROPOSAL |
| TRANSMITTER | RBS57020-502 | 4.1488 | 942117B VOL II |
| REGULATOR | RBS57030-502 | 3.0736 | (DESCRIPTION OF |
| ENABLE/DISABLE | RBS57040-502 | 5.8106 | OPTIMUM SYSTEM) |
| RECEIVER (2 EA) | RBS120020-501 | 5.3576 | REMBASS, DATED |
| DIPLEXER (2 EA) | RBS117530-501 | 2.7888 | 28 MARCH 1977. |
| STORE & FWD LOGIC | RBS120040-501 | 23.9848 | " |
| SWITCHES | 14 EACH | 19.6000 | " |
| BATTERY (9 EA) | BA5590/U | NOTE 1 | " |

NOTE 1 -- Battery not included in success probability since it is replaceable w/in 5 minutes.

Total Failure Rate = 127.2
(FX10E-6HRS)

Mean Time Between Failures = 7,862 Hrs.

TABLE B.1.11
FAILURE RATE ASSESSMENT, ALTERNATIVE 5 REPEATER

| MODULE NAME | DRAWING NUMBER | FAILURE RATE (FX10E-6HRS) | FAILURE RATE SOURCE |
|-----------------------|----------------|------------------------------|------------------------|
| PROGRAMMER (2EA) | RBS56240-501 | 62.4384 | (U) RCA PROPOSAL |
| TRANSMITTER | RBS57020-502 | 8.2976 | 942117B VOL II |
| REGULATOR | RBS57030-502 | 3.0736 | (DESCRIPTION OF |
| ENABLE/DISABLE (2 EA) | RBS57040-502 | 11.6212 | OPTIMUM SYSTEM) |
| RECEIVER | RBS120020-501 | 2.6788 | REMBASS, DATED |
| DIPLEXER (2 EA) | RBS117530-501 | 2.7888 | 28 MARCH 1977 |
| STORE & FWD LOGIC | RBS120040-501 | 23.9848 | " |
| SWITCHES | 14 EACH | 19.6000 | " |
| BATTERY (9 EA) | BA5590/U | NOTE 1 | " |

NOTE 1 -- Battery not included
in probability model because
it is replaceable w/in 5
minutes of failure.

Total Failure Rate = 134.5
(FX10E-6HRS)

Mean Time between Failure = 7,435 Hrs.

APPENDIX C
C1. SEAOPSS OVERVIEW

C.1 GENERAL

Five versions of a Phase III Portable Command Transmitter (PCT) were developed for use with both digital and analog unattended ground sensor (UGS) equipment. The following is a brief description of the command link, the sensors, and the decoding logic employed in support of SEAOPSS and Battle Area Surveillance System (BASS) operations.

C.1.1 Portable Command Transmitters (PCT)

This paragraph briefly outlines the Defense Special Projects Group (DSPG) approach to Phase III portable command transmitters of the MA-46 family of equipment. These devices permit tactical forces to exercise the command capabilities of (certain) Phase III equipment. Under manual control of the operator, front panel switches are used to enable the PCT to generate and transmit commands to remotely located devices. The PCT can also be employed as a test generator, or it can be used to transmit to a commandable repeater to allow communications sensors masked from direct LOS transmission paths. Figure C.1.1.1 illustrates the equipment under discussion.

C.1.1.1 Operational Characteristics. The PCT (MA-46) was built in five models according to the transmitter frequency and special functions:

| <u>Model</u> | <u>Frequency</u> | <u>Function</u> |
|--------------|------------------|--|
| MA-46 | 316.5 MHz | Transmits directly to Phase III commandable sensors. |
| MA-46-1 | 319.8 MHz | Transmits to BASS I command relay. |

| <u>Model</u> | <u>Frequency</u> | <u>Function</u> |
|--------------|------------------------|--|
| MA-46-2 | 321.1 MHz | Transmits to BASS III command relay. |
| MA-46-3 | All Three | Transmits to sensors directly or through BASS I/III or any command relay. |
| MA-46-4 | 316.5 MHz 321.1 MHz | Transmits to Covert Observation Device (COD) directly or through BASS III command relay. |

C.1.1.2 Design Features. The Phase III PCT is a rugged, self-contained battery powered, portable field unit designed to command field deployed Phase III commandable sensors at ranges up to 1 Km with a nominal 10 Watt power output. It may also be used as a local command transmitter for sensor system checkout using a low power output mode that delivers 10 milliwatt power output. Other features include small size, lightweight, rechargeable/replaceable battery pack with built-in charger, pushbutton code set-ups, numerical display of entered codes, end of transmission (EOT) indicator, battery condition indicator, and a single-hand carry/operate capability. The unit requires no warm-up time, field adjustments or calibration. Separation of the case is required only when battery package exchange is required. Figure C.1.1.2 illustrates the front panel layout of the MA-46 family of PCT.

When used at a fixed site, the PCT can be connected to an elevated antenna; it can also be used to drive an RF power amplifier both of which will help obtain increased range.

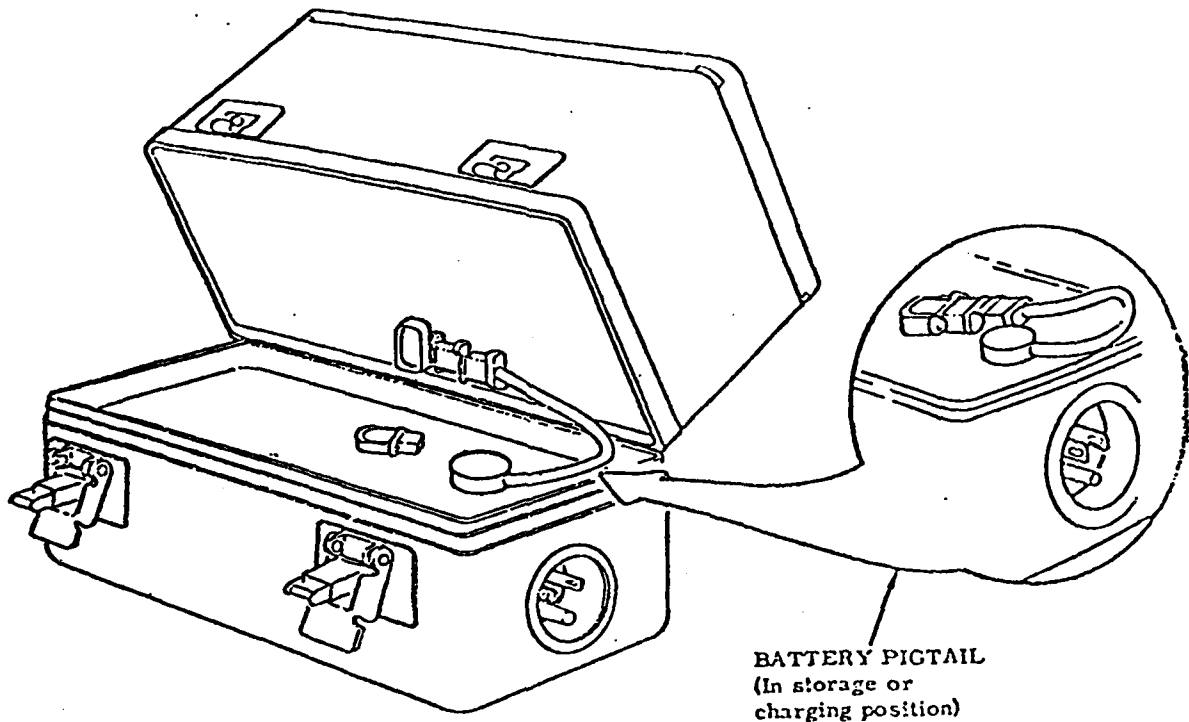

FIGURE C.1.1.1 MA-46- Portable Command Transmitter

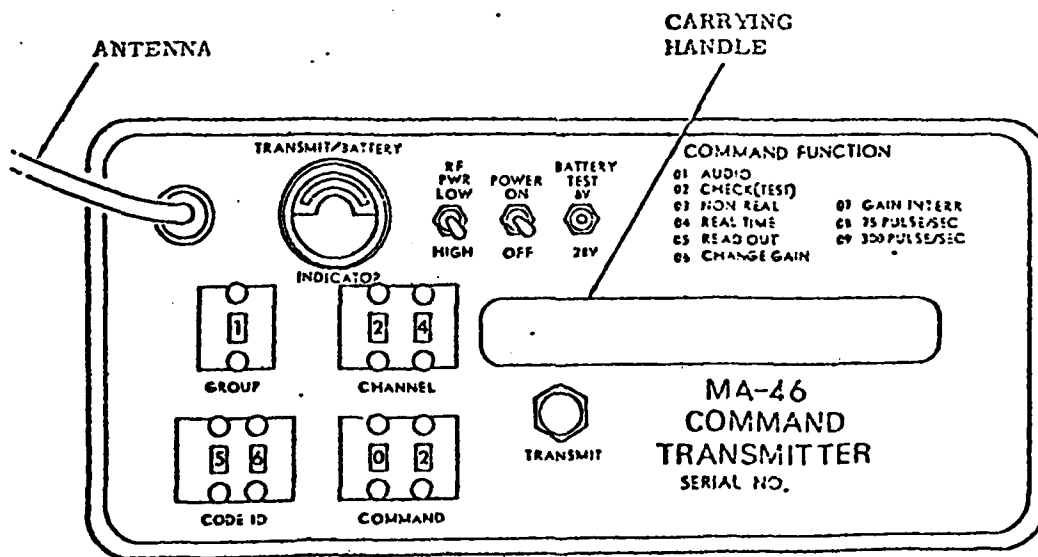

FIGURE C.1.1.2. MA-46- Portable Command Transmitter
Front Panel Layout.

The MA-46-3 model can be switched to transmit directly to sensors, or to command relays.

The MA-46-4 model has all the features of the MA-46-3; in addition to providing operating compatibility with the COD.

C.1.1.3 Interface Design. The PCT is designed to command Phase III sensors with any of the command addresses. Sandia's ACOUSID III (reference Figure C.1.1.3) is representative of a commandable tactical sensor for use with the PCT. Sixteen command formats are possible; 9 of which are assigned. The ACOUSID III uses the first seven.

TABLE C.1.1.1. COMMAND MESSAGES

Command Message

- 01 = Send Audio
- 02 = Check Mode and/or sensitivity
- 03 = Go to Non-real Time (NRT)
- 04 = Go to Real Time (RT)
- 05 = Read Out Stored Events
- 06 = Change Sensitivity
- 07 = Check Sensitivity
- 08 = Go to 75 PPS
- 09 = Go to 300 PPS

C.1.1.4 Command Functions. Figure C.1.1.2 illustrates the front panel layout of the MA-46 Portable Command Transmitter (PCT). Shown left-center are two individual switches as follows:

- A single digit switch labeled GROUP
- A two-digit switch labeled CHANNEL

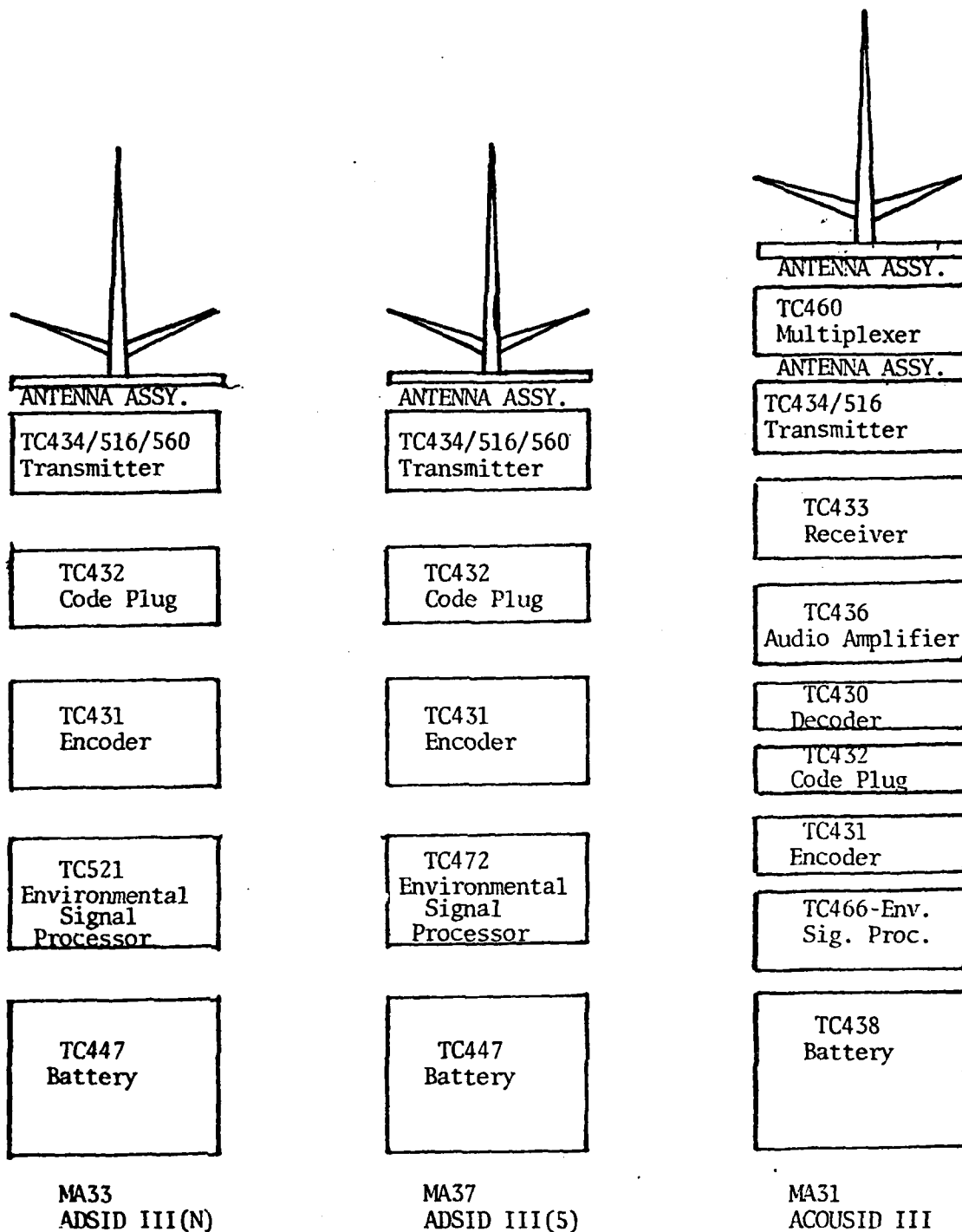

FIGURE C.1.1.3. Commandable ACOUSID III (right), and non-commandable ADSID III(N), (left) and ADSID III(S), (center).

These two switches are used in conjunction with logical functions assigned with -- and burned into -- a sensor's programmable code plug (i.e., TC432, etc.). They have no relationship with any RF channel*, RF channel group, etc. A more proper name for these two switches would be (data) Channel Call Number (CCN) switches. Certain "call numbers" have been set aside for use with particular commandable Phase III devices (i.e., COD). Before assigning a CCN into the programmable code plug, it must first be ascertained that the CCN is not reserved for special use, and also that IDs are available for use on the sensor's VHF (talk in) channel. For all sensors employing programmable code plugs (whether commandable or non-commandable sensor) the CCN should be specified even though the plug is employed in a non-commandable sensor (which does not utilize a CCN for its performance) for the following reasons; (a) the programmer is never in doubt as to whether the CCN was inadvertently omitted, and (b) it removes the possibility that failure to program a CCN will cause an unprogrammed parameter to overload the sensor's power source.

C.1.1.4.1 Channel Call Numbers (CCN). The full 4 k/ baud, 5-ms, 20-bit PCT "message" and "message enable" arrangement is described in Section C.1.2.1. Figure C.1.1.2 shows the specific arrangement and binary values of the CCN-portion of the PCT's message. This is entered into the system using the GROUP and the CHANNEL switches in combinations such as A-BC, X-YZ, A-XY, etc.

*Even the PT-1561, Programmer, Code Plug errs in referring to this function as "RF CHANNEL." See photograph, Fig. C.1.1.2.

C.1.2 CODE PLUGS, ENCODERS, AND DECODER MODULES

This section briefly outlines the arrangement between the "intelligent" portion of typical Phase III SEAOPS family of sensors. Intelligence was contained in the following common module elements:

Code Plug (TC432)

Encoder (TC431)

Decoder (TC430)

Other elements which comprise a sensor's "stack" are illustrated in Figure C.1.1.3; these include transmitters, receivers, signal processors, etc.

The Phase III MINISID is a sensor which did not employ the TC 432 Code Plug; control over the sensor's sensitivity, data rate, parity, and ID are contained in a pin-staple strapping arrangement which is part of the self-contained plug which constitutes a portion of the Sensor Contained Unique Electronics (SCUE). Apart from the transmitter, the only other common module employed in a MINISID is the "Z Plug" i.e., the TC431 Encoder.

C.1.2.1 Commandable Sensors. Commandable devices such as the COMMIKE and ACOUSID III (and certain non-commandable sensors) were designed for use with the common module Code Plug TC432; this code plug is used in conjunction with both the encoder and decoder in commandable sensors, and only with the encoder in non-commandable devices. When properly programmed, the Code Plug acts as a read-only memory (ROM) for the sensor. The Code Plug control 8 individual parameters which are "burned" into the Code Plug using the Sandia Code Plug Programmer PT-1561. These eight parameters include:

- | | |
|-------------------------------|--------------------|
| 1. Channel Call Number (CCN) | |
| 2. Sensor ID | |
| 3. Response Data Bit Rate | VIA ANY ONE OF |
| 4. Long or Short Message Code | SEVENTEEN SETTINGS |
| 5. Message Type | OF THE PT-1561 |
| 6. Initial Operating Mode | "FUNCTION SWITCH" |
| 7. Audio Time | |
| 8. Sensor Gain Setting | |

C.1.2.2 Decoder TC-420. This is a sealed unit which receives a command message from an interfacing radio receiver (within the sensor) that contains an address and a command. The decoder works with an external device to accomplish a sensor recognition operation on address bits in the message. If the address is recognized as correct, the decoder decodes the command bits, furnishes a command pulse to an appropriate "command" line and sets the coding on other lines peculiar to the needs of the decoded command. The decoder also incorporates memories of the current operating mode, a register to count incoming pulses on a line other than the message input line, a selectable interval timer, a fixed interval timer to limit decoder "on" time, and a bit rate memory.

C.1.2.2.1 Decoder Functional Components. Typically, the decoder incorporated the following functional components:

- a. A shift register to receive the input message.
- b. A fixed interval shutdown timer.
- c. A binary counter, triggered by external pulses, from sources other than those from the receiver.
- d. A message parity error detection circuit.

- e. An initial operating mode selection circuit.
- f. Message bit error shut-down circuitry.
- g. Internal memory for (1) "operating mode," (2) "bit rate," and (3) "audio."
- h. An internal timer for externally programmable time intervals (i.e., 1.25, 5, 10- or 20-second "time on" intervals).
- i. 16 command decoding elements.*

C.1.2.2.2 Decoder Functions. The decoder is activated (i.e. full power applied to the sensor's digital sections) by a specific output signal from the sensor's internal receiver. This activation is: (1) 30 milliseconds of no signal, (2) 8-milliseconds of 10 KHz sinusoidal modulation in the voltage range of 2 to 4.5 volts; (3) a 2-millisecond pause, and (4) a 20-bit digital message originated by the PCT.

C.1.2.2.3 Analog Command Times. As mentioned previously the acoustic event turn-on time interval was adjustable within the code plug during "burn in." The decoder includes an analog transmission and power control timer, capable of being programmed by external voltage inputs to two connector pins; this timer maintains voltage on an output line for 1.25, 5, 10 or 20 seconds as determined by voltage coding. Figure C.1.1.4 illustrates the total sequence of events over the 45-millisecond message sequence.

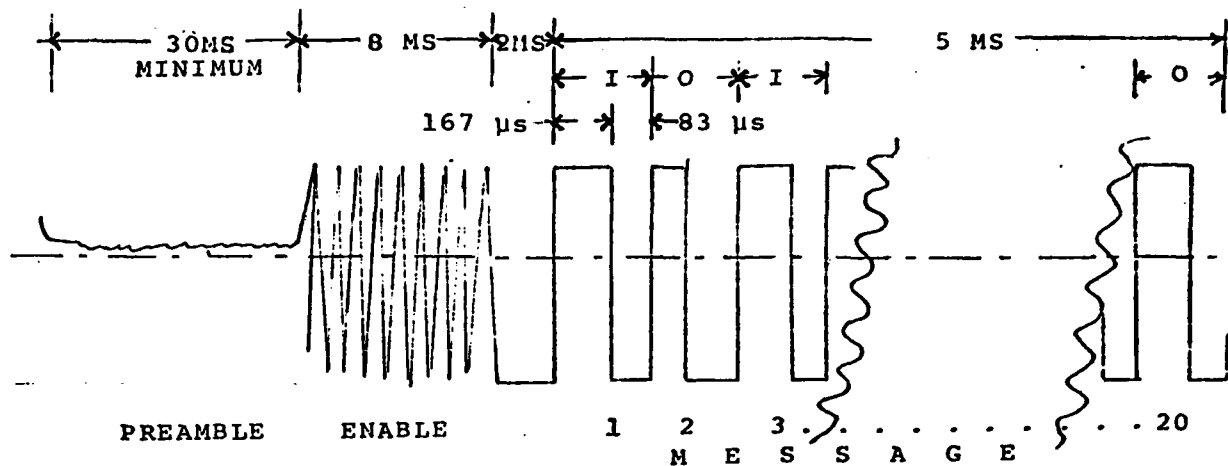

FIGURE C.1.1.4. Input to decoder, output from portable command transmitter (PCT).

C.1.3 MULTIPURPOSE FUNCTIONS

The following section provides a brief overview of the various sensor functions under control of Code Plug TC432 and used in conjunction with the Portable Command Transmitter (PCT).

C.1.3.1 Code Plug Program Selections. There are eight code plug programmable parameters. Four are independently controlled and four are collectively controlled under a valid setting of the PT-1561's FUNCTION switch. The individually programmed items consist of: (1) CCN (which in turn is comprised of GROUP and CHANNEL numbers); (2) Sensor ID, (3) sensor's audio response time, and (4) sensor's gain setting. The multipurpose elements (under control of the function switch) permit the following additional features to be selected: (1) Response data bit rate (75, or 300 bps), (2) long (24 bit) or short (18 bit) message, (3) Message Type (I, IIA, IIB, III), and (4) initial operating mode (RT or NRT).

C.1.3.2 Message Types. Four different message types are available and can be specified; these are briefly outlined below.

C.1.3.2.1 Type I Message. A type I message is formed by the combination of the preamble (8 bits), "frame marker" (1 bit); message type (2 bits); sensor ID (6 bits) and parity (1 bit). This message type is referred to also as the "short" or 18-bit detection message. The data rate could be either 75 or 300 baud.

C.1.3.2.2 Type IIA Message. A Type IIA message is formatted from the "short" or 18-bit message with six bits of digital data added. The IIA message (at either 75- or 300-bps) is in response to PCT Command #5 (READ OUT) whether the sensor was in a real time (RT) or non-real time(NRT) operating mode. Up to 63 accumulated events (binary 0 0 0 0 0 1 to binary 1 1 1 1 1 1) in sensor bit positions 19 - 24.

C.1.3.2.3 Type IIB Message. A Type IIB message is also appended to the 18-bit or "short" (Type I) message to form a 24-bit message; the data contained indicates the current sensor operating mode (bits 19 and 20), and gain setting (bits 21-24). In the RT mode, IIB messages responded to 02, 03, 04, and 06 commands. In a NRT mode, a IIB message response was associated with command 01 (SEND AUDIO).

C.1.3.2.4 Type III Message. A Type III message is formed by the addition of a pre-programmed audio burst following the Type I (18-bit) message. Both ACOUSID III and COMMIKE outputted this type of message. The Type III message is only in response to a RT mode, 01 (SEND AUDIO) Command.

APPENDIX D

SENSOR AND REPEATER MODIFICATION

D.1.1 ALTERNATIVE METHODOLOGY FOR SENSOR MODIFICATIONS

D 1.2 COMMANDABLE SENSORS HARDWARE MODIFICATIONS

Three methodologies for the reconfiguration of a typical hand emplaced sensor into a commandable device are illustrated. The alternatives illustrated trade off the following; (1) maximum use of existing sensor electronics and components, (2) maximum frequency agility, (c) power budget, and (d) cost considerations.

D.1.2.1 Alternative 1. Of the three alternatives, the first (Figure 2.1.1) makes maximum use of sensor on-board electronics. The sensor is in a continuous receive mode, except when the encoder temporarily seizes control of the unit. The sensor can be arranged to operate in a simplex (F_1 RX/ F_1 TX) mode, or in a half duplex (HDX) (F_1 RX/ F_2 TX) mode.

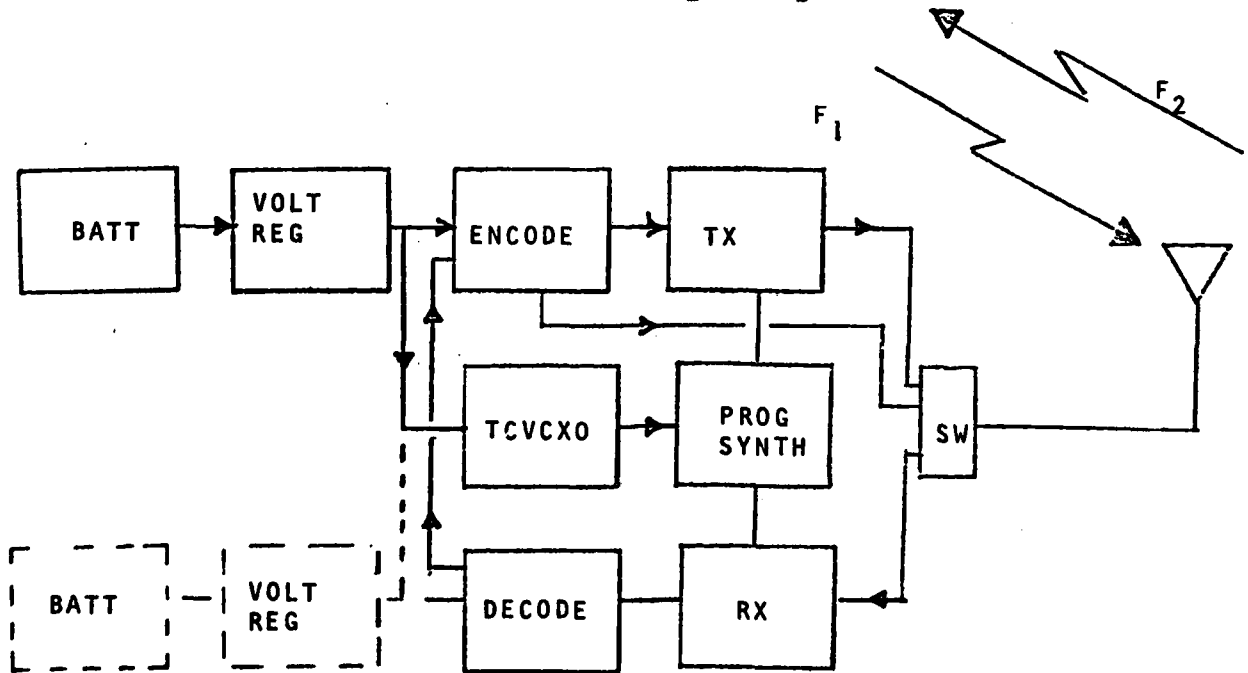

FIGURE D.1.1. Alternative 1, employing common TCVCXO and Programmer/Synthesizer. Two frequency, half duplex(HDX)operation is shown.

The common driver arrangement requires the addition of new components and the modification of existing on-board electronics as shown.

| MODIFICATION | IMPACT |
|---|--|
| 1. Add diode switch between antenna and RF modules | 1. Required on all designs. |
| 2. Add receiver (simplex) | 2. Required on all designs. |
| 3. Add receiver (HDX) | 3. Requires additional frequency select switches, and modification to encoder for F_1/F_2 shift. |
| 4. Add decoder | 4. Required on all designs. |
| 5. Modify encoder to accept and respond to commands | 5. Required on all designs |
| 6. Modify or add additional battery | 6. Continuous running of TCVCXO and Programmer/Synthesizer will impose additional current drain. |

D.1.2.2 Alternative 2. The second of the three alternatives provides for a limited number of crystal controlled receive channels, and a full compliment of synthesizer controlled transmit channels (Figure D.1.2). Fixed frequency receive operation was characteristic of SEAOPSS; although three crystals are shown up to 10 crystals and selector switch can be accomodated in today's hand-held industrial two-way radio systems. Typical cost of REMBASS crystals is \$15 - \$18 each. The major advantage to crystal control operation is the very low power drain associated with this concept. Proposed duty cycles, and the use of improved front end detection logic in the DT-563 could permit operation without the addition of extra batteries. This concept also maximizes sensor on-board electronics. The sensor is in a continuous receive mode except when the encoder (temporarily) seizes control of the device, and furnishes bias voltage to the diode switch. Operation is frequency independent, i.e., it could be either simplex or half duplex, however, due to the limited number of receive channels, the latter arrangement (F_1/F_2) would probably be preferable. The crystal control receiver arrangement requires the addition of new components and the modification of existing on-board electronics as follows:

| MODIFICATION | IMPACT |
|---|---|
| 1. Add diode switch between antenna | 1. Required on all designs. |
| 2. Add (crystal controlled) receiver | 2. Receiver required on all designs. |
| 3. Add Decoder module | 3. Required on all designs. |
| 4. Modify Encoder to accept and respond to commands | 4. Required on all designs. |
| 5. Battery | 5. With (proposed) 1-minute delay between 15" audio bursts, and use of VFP to reduce unwanted activations of the DT-563, the unit could possibly function over most climatic zones with no additional battery due to the low current drain imposed by crystal receiver. |

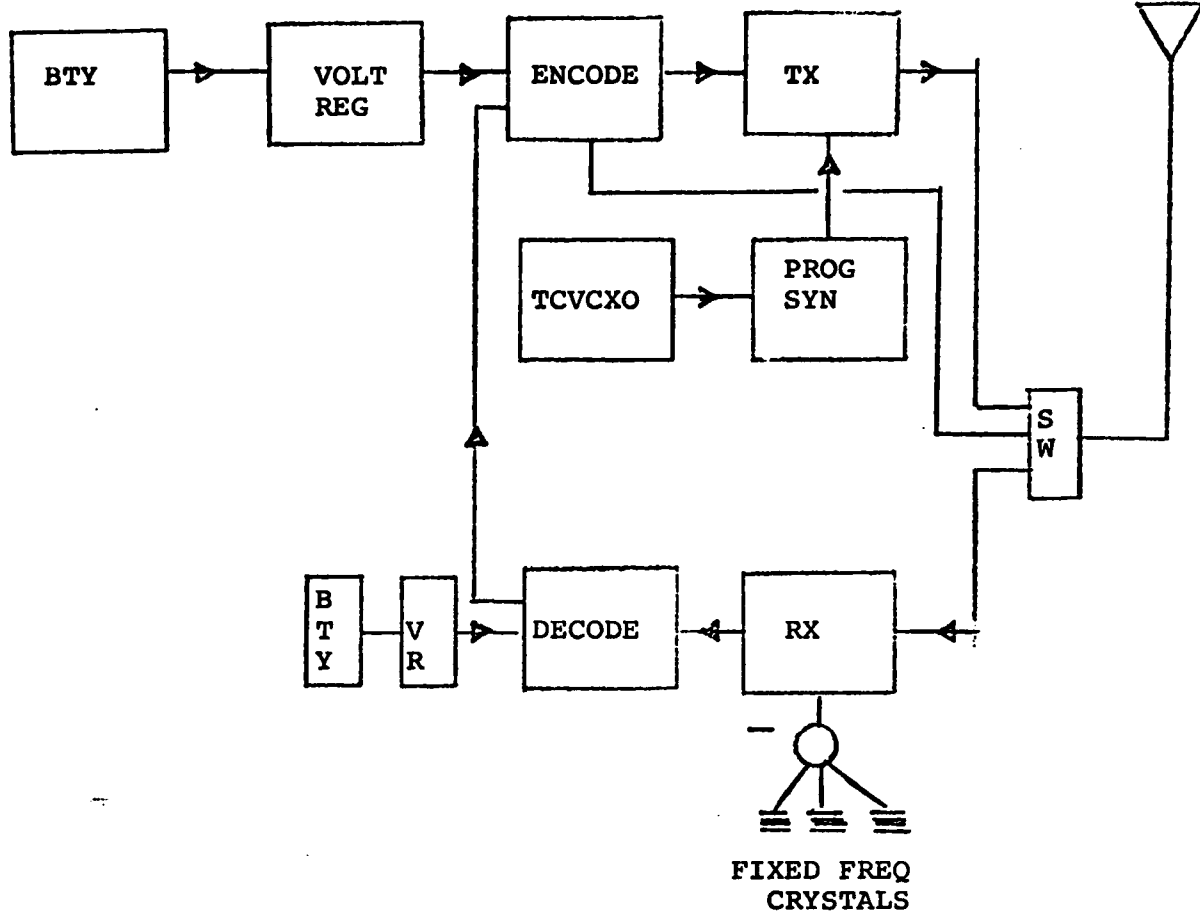

FIGURE D.1.2. Alternative 2, Crystal controlled receiver. Three crystal channels are shown, but 6 to 10 are presently employed in high quality hand held industrial radios.

I

D.1.2.3 Alternative 3. This configuration employs independent TCVCXO and Programmer/Synthesizer to operate the command link receiver. Little, if any, improvement in frequency agility over Alternative 1 is provided (Figure D.1.3). Costs associated with this arrangement are the highest; the TCVCXO is currently estimated at \$350.00 plus an additional \$18 for the crystal. Modifications required are essentially the same as for other alternatives. Additional battery will be required to maintain the synthesizer driven command receiver over a virtual 100% duty cycle.

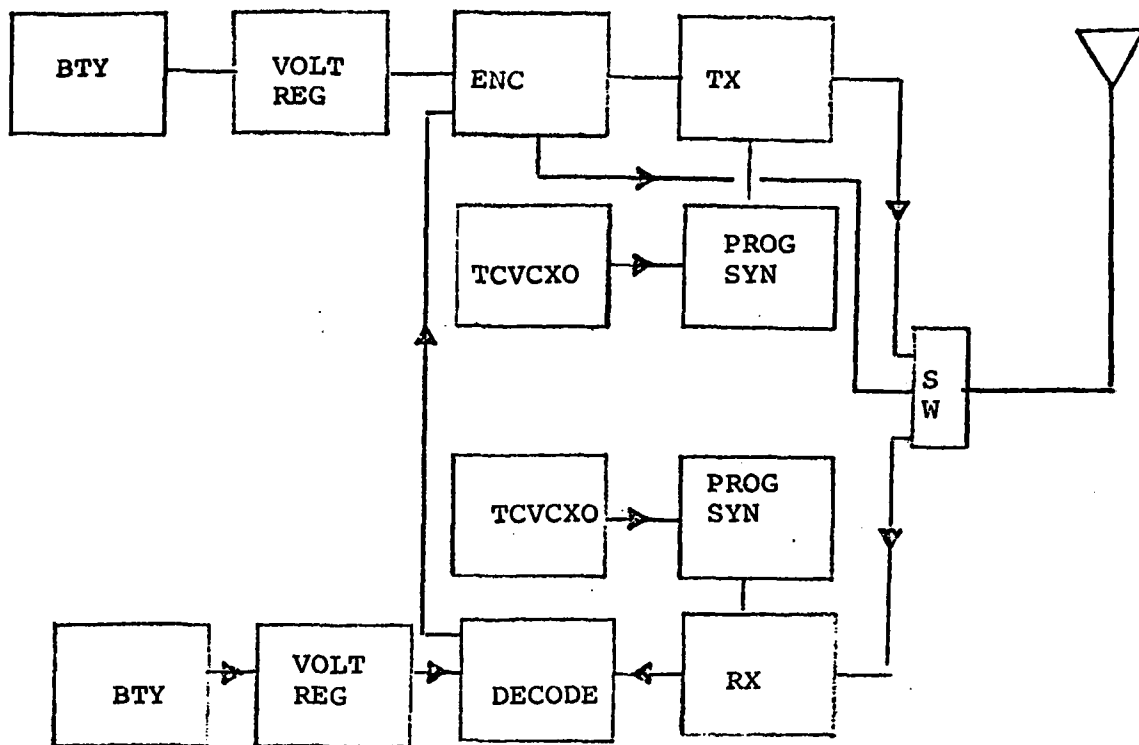
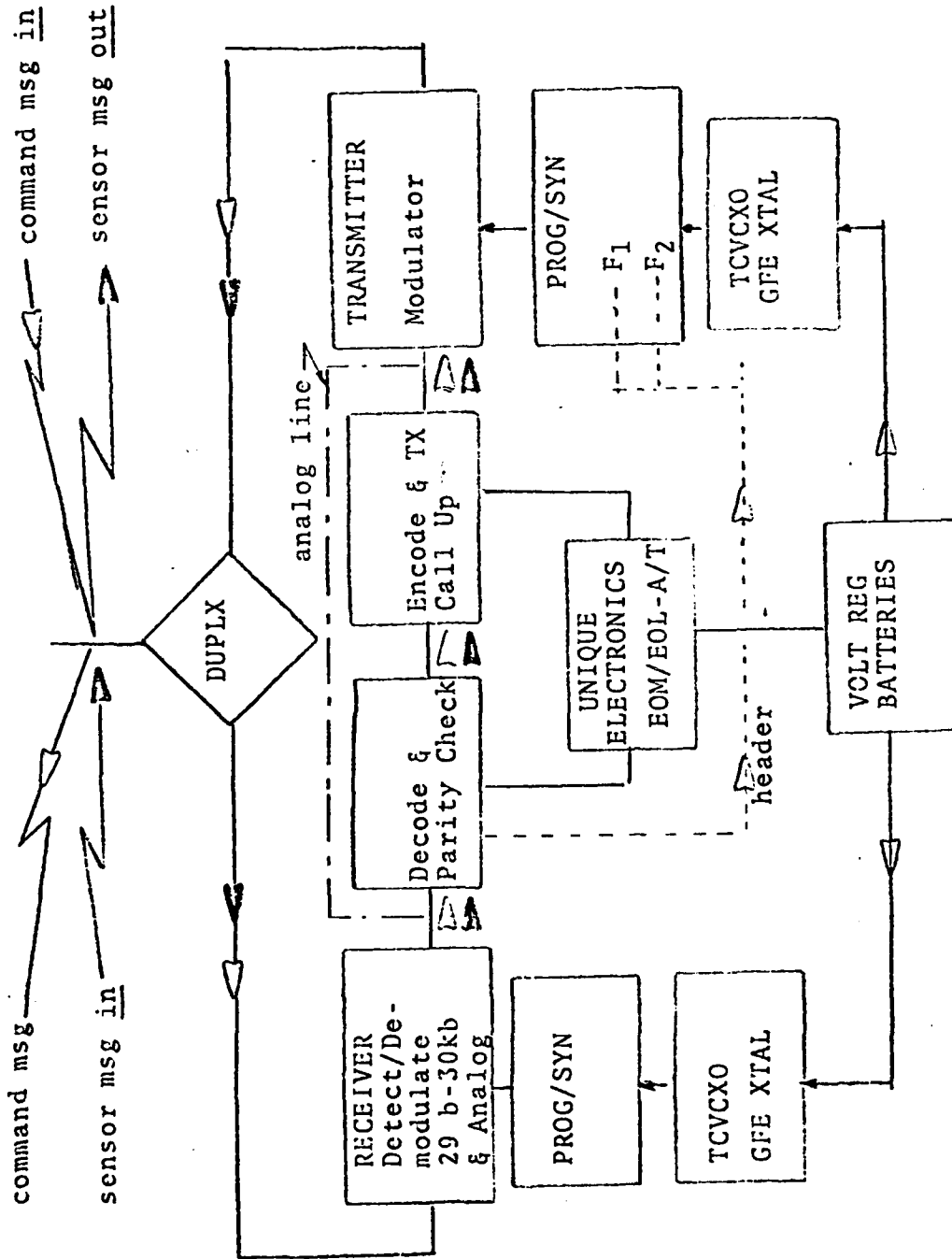

Figure D.1.3. Dual TCVCXO, Programmer/Synthesizer arrangement. This configuration provides for highest cost (i.e., dual frequency drivers) with no substantial increase in performance, or operational flexibility.

D.2.1 REPEATER MODIFICATION

The repeater modification depicted in Figure D.2.1 shows a method that may be used in Alternative 5 of TOD/TOA analysis.



▽ command lines(digital)
 - - - analog lines
 ▽ sensor digital lines
 ····· header F1/F2 line

FIGURE D.2.1 - Repeater Modification



APPENDIX E

DEPARTMENT OF THE ARMY

PROJECT MANAGER, REMOTELY MONITORED BATTLEFIELD SENSOR SYSTEM, ~~XXXX~~ DARCOM
FORT MONMOUTH, NEW JERSEY 07703

DRCPM-RBS-T

1 November 1977

MEMORANDUM FOR: RECORD

SUBJECT: Timing Aspects of Analog Sensor DT-563

1. Meeting was held on 28 October 1977 to address the timing aspects of analog transmissions from a system standpoint.
2. Attendance list of personnel attending is provided in inclosure 1.
3. Review of DT-563 Specification: Discussion addressed aspects related to the specified method of triggering, analog transmission time, seismic gain control, and automatic gain control.
4. RCA's current approach: Reported that RCA is considering (a) the use of the same logic that is used to turn on the AAU, and (b) a method of turn-on as a function of target speed. RCA had indicated that they have the AAU documentation including logic design. RCA offered to provide information about turn on as a function of target speed in the near future. During the discussion Phil Hartmann suggested that the VFP logic be used instead of the MINISID logic because VFP logic has proved superior. Mr. Hartmann will check on the availability of VFP logic documentation including models which may be released to RCA. This design would be provided for RCA's consideration, not imposed on RCA. However, it was concluded that RCA should be instructed that the development of a new design is unacceptable.

5. Timing Aspects:

- a. The following definitions were agreed upon:

Turn-on Time. The time between the initial seismic detection of the analog sensor and initiation of the analog transmission.

Transmission Time. The time duration of the analog transmission.

Delay Time. The minimum time between the completion of an analog transmission and the initiation of the following analog transmission.



1 November 1977

SUBJECT: Timing Aspects of Analog Sensor DT-563

b. The discussion addressed the following factors:

Target Speed. Considered vehicle speeds of 5 to 60 miles per hour and walking personnel.

Target Rate. Estimated 2 sec to 6 sec per target (personnel and vehicle) for a target column.

Convoy Size. Considered a convoy to consist of at least six vehicles and a large convoy to consist of approximately 100 vehicles.

Sensor Spacing. Considered sensors emplaced a minimum of 200 meters apart.

Analog Need. Considered analog sensors would be used only in a confirming role; never used alone.

Operator Alert. Considered operator pre-alert for audio by means of sensor string data.

c. Turn-on Time: Turn-on time was deemed more important to the single target than a convoy. A 20 second turn-on time is estimated to provide (1) audio when the most favorable signal to noise ratio exists and (2) an operator with approximately 10 seconds pre-alert. This pre-alert is provided by reports from companion sensor(s) in the deployed string. This approach is considered adequate for operator needs and precludes the need for the analog sensor to transmit a detection message for the purpose of alerting the operator that audio is coming. The SMS will provide a unique tone to identify when audio is starting.

d. Transmission Time: While there are reasons to both increase and decrease the specified 15 sec of audio, it was concluded that 15 sec is appropriate. Flexibility in the RCA design to accommodate a change in transmission time needs to be pursued. For the purpose of operator confirmation of the presents of a convoy by means of audio, it was concluded that a proposed short transmission time (6 sec) would not be adequate and that 15 sec was deemed suitable for this purpose.

e. Delay Time: A wide range of delay times from 5 sec to 2 min proposed by Gas Woodbridge was discussed. The principle factors that led to the selection of a 1 min delay time were the following:

(1) Sensor battery life is highly dependent on the number of analog transmissions.

(2) RF transmission occupancy time must be minimized.

(3) Operator needs for audio are limited (based on confirming role) which is easily satisfied with the 1 min delay time.

DRCPM-RBS-T

1 November 1977

SUBJECT: Timing Aspects of Analog Sensor DT-563

Both individual targets and convoys were considered in the discussion. It was concluded that for a large convoy approximately 3 to 10 analog transmissions would occur (using a 1 minute delay time) during the convoy passage.

6. Recommendation: That RCA be provided the following guidance:

- a. Development of a new detection logic for the analog sensor is unacceptable.
- b. Turn-on time shall be 20 ± 1 seconds.
- c. Transmission time shall be 15 ± 1 seconds as specified.
- d. Delay time shall be $1 \pm .25$ minutes.

1 Incl
as

Edward J. Kaiser
EDWARD J. KAISER
Acting Chief
Technical Management Division

RECEIVING PAGE DELETED FILMED

APPENDIX F
LIST OF REFERENCES

1. REMBASS System Specification RBS-001, 19 Nov. 1975.
2. REMBASS Environmental Specification RBS-002, 19 Nov. 1975.
3. REMBASS Detection Sensors Specification RBS-003 19 Nov. 1975.
4. REMBASS Classification Sensors Specification, 19 Nov. 1975.
5. REMBASS Repeater Specification RBS-005, 19 Nov. 1975.
6. REMBASS Antenna Group Specification RBS-006, 19 Nov. 1975.
7. REMBASS Sensor Monitoring Set Specification RBS-007, 19 Nov. 1975.
8. REMBASS TCVCXO Specification RBS-990, 19 Nov. 1975.
9. REMBASS Infrared Sensor Specification RBS-010, 19 Nov. 1975.
10. REMBASS Analog Sensor Specification RBS-012, 1 March 1976.
11. Letter, w/incl. AMCPM-RBS-T, Subject: Sensor Radio Relay Study, 12 February 1973.
12. REMBASS Preliminary System Description, 1 October 1973.
13. Dictionary of Unique REMBASS and Related Sensor Systems, February 1976.
14. Letter, w/incl. CDCMS-E, DA Approved Materiel Need (MN) for REMBASS 4 April 1972.
15. Letter w/incl., ATCD-SC-I, REMBASS Materiel Need Revision, 26 June 1976.
16. RCA Remotely Monitored Battlefield Sensor System (REMBASS) Vol. II Proposal No. 942117B, 28 March 1977.
17. Letter w/incl. ATCD-SC-S, REMBASS Materiel Need Revision, 16 April 1976.
18. Appendix G, REMBASS Data Transmission Subsystem Tradeoff Determination, 23 June 1972.
19. Letter w/incl. 1-9, ATSI-CD-OR, 17 August 1977, Subject: Basis of Issue Plan for REMBASS.

Preceding Page BLANK - FILMED

UNCLASSIFIED

SECURITY CLASSIFICATION OF THIS PAGE (When Data Entered)

| REPORT DOCUMENTATION PAGE | | READ INSTRUCTIONS BEFORE COMPLETING FORM |
|---|---|---|
| 1. REPORT NUMBER (18) <u>ECOM 77-63861</u> ✓ | 2. JOVT ACCESSION NO. | 3. RECIPIENT'S CATALOG NUMBER |
| 4. TITLE (and Subtitle) REMBASS Commandability, Trade Off Analysis (TOA)/Trade Off Determination (TOD) . | 5. TYPE OF REPORT & PERIOD COVERED Technical Report (Final) 15 June - 15 Oct 77 | 6. PERFORMING ORG. REPORT NUMBER 1245.5-B ✓ |
| 7. AUTHOR(s) Delmar G. Baker | 8. CONTRACT OR GRANT NUMBER(s) DAAR07-77D-6386 | 9. PERFORMING ORGANIZATION NAME AND ADDRESS Analytics 766 Shrewsbury Avenue Tinton Falls, New Jersey 07724 |
| 10. CONTROLLING OFFICE NAME AND ADDRESS PM REMBASS US Army Electronics Command Ft. Monmouth, N. J. 07703 | 11. REPORT DATE 15 Dec 1977 | 10. PROGRAM ELEMENT, PROJECT, TASK AREA & WORK UNIT NUMBERS 643704, K730012 1X463704DK73 |
| 14. MONITORING AGENCY NAME & ADDRESS (if different from Controlling Office) Final technical rept. 15 Jun - 15 Oct 77 | 12. NUMBER OF PAGES 150 | 15. SECURITY CLASS. (of this report) UNCLASSIFIED |
| 16. DISTRIBUTION STATEMENT (of this Report) Approved for public release; distribution unlimited. 12 155p. | | 15a. DECLASSIFICATION/DOWNGRADING SCHEDULE |
| 17. DISTRIBUTION STATEMENT (of the abstract entered in Block 20, if different from Report) N/A | | |
| 18. SUPPLEMENTARY NOTES N/A | | |
| 19. KEY WORDS (Continue on reverse side if necessary and identify by block number) Sensors, Detectors, Images, Trade Off Analysis, Trade Off Determination, Remote Systems, Battlefield Surveillance, Communications, Data Transmission Systems Trade Off Determination. REMBASS Commandability. | | |
| 20. ABSTRACT (Continue on reverse side if necessary and identify by block number) → This is a Trade-Off Analysis and Trade-Off Determination to analyze and rank various system-level and contract end relationships to fulfill the commandability requirements stated in the Remotely Monitored Battlefield Sensor System (REMBASS) materiel need. Six alternative configurations were analyzed from a technical, operational, tactical and management assess- ment in determining the most desirable system configuration for adding a command capability to remote sensors. ↗ | | |

DD FORM 1473 1 JAN 73

EDITION OF 1 NOV 65 IS OBSOLETE

388 996

UNCLASSIFIED

SECURITY CLASSIFICATION OF THIS PAGE (When Data Entered)

13

SECURITY CLASSIFICATION OF THIS PAGE(When Data Entered)

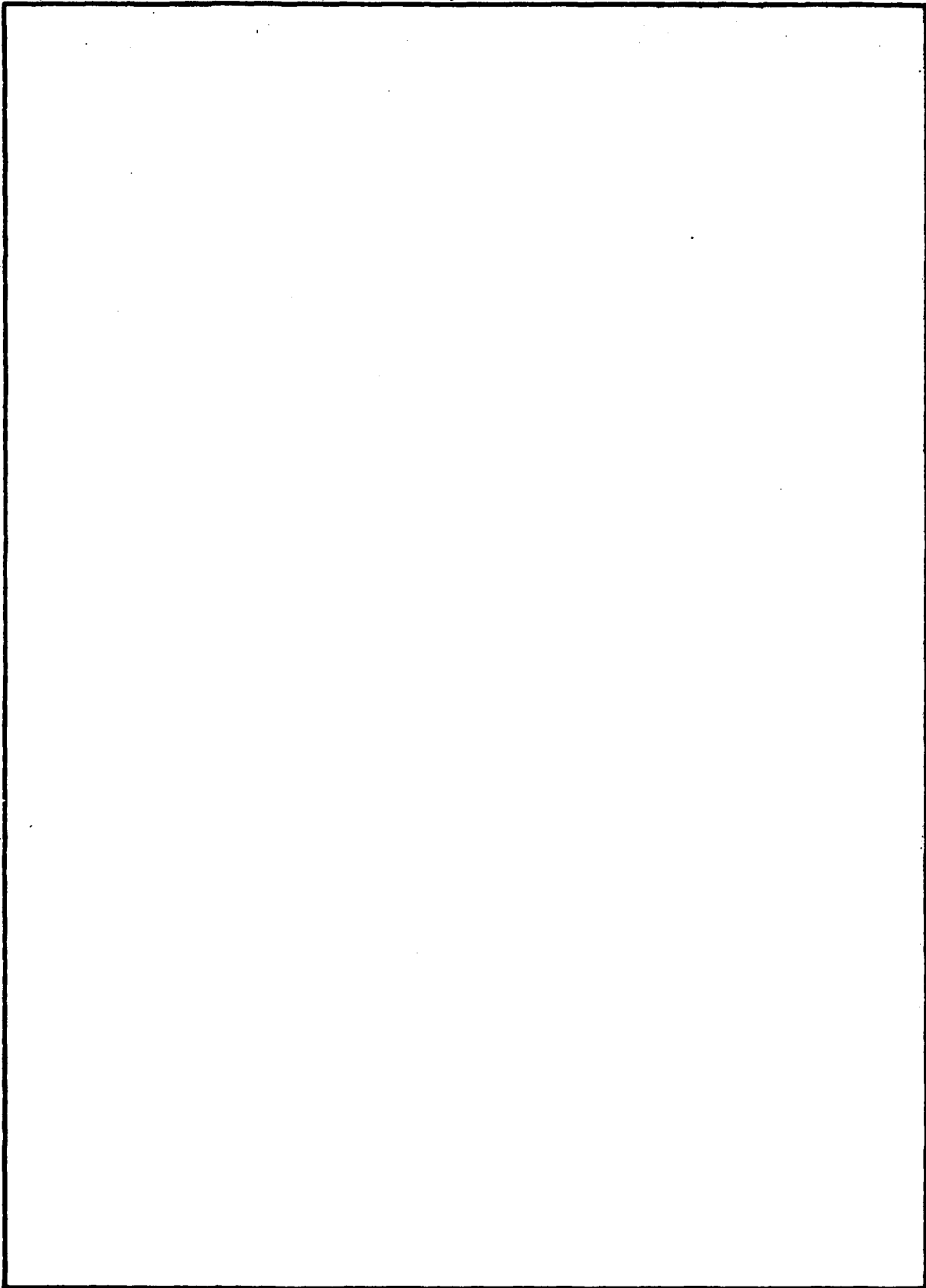

SECURITY CLASSIFICATION OF THIS PAGE(When Data Entered)