

AD-A048 409

NAVAL POSTGRADUATE SCHOOL MONTEREY CALIF
EXPERIMENTAL STUDY OF NATURAL CONVECTION IN THIN HORIZONTAL LIQ--ETC(U)
SEP 77 M YURTERI

F/G 20/13

UNCLASSIFIED

NL

1 OF 1
AD
A048409

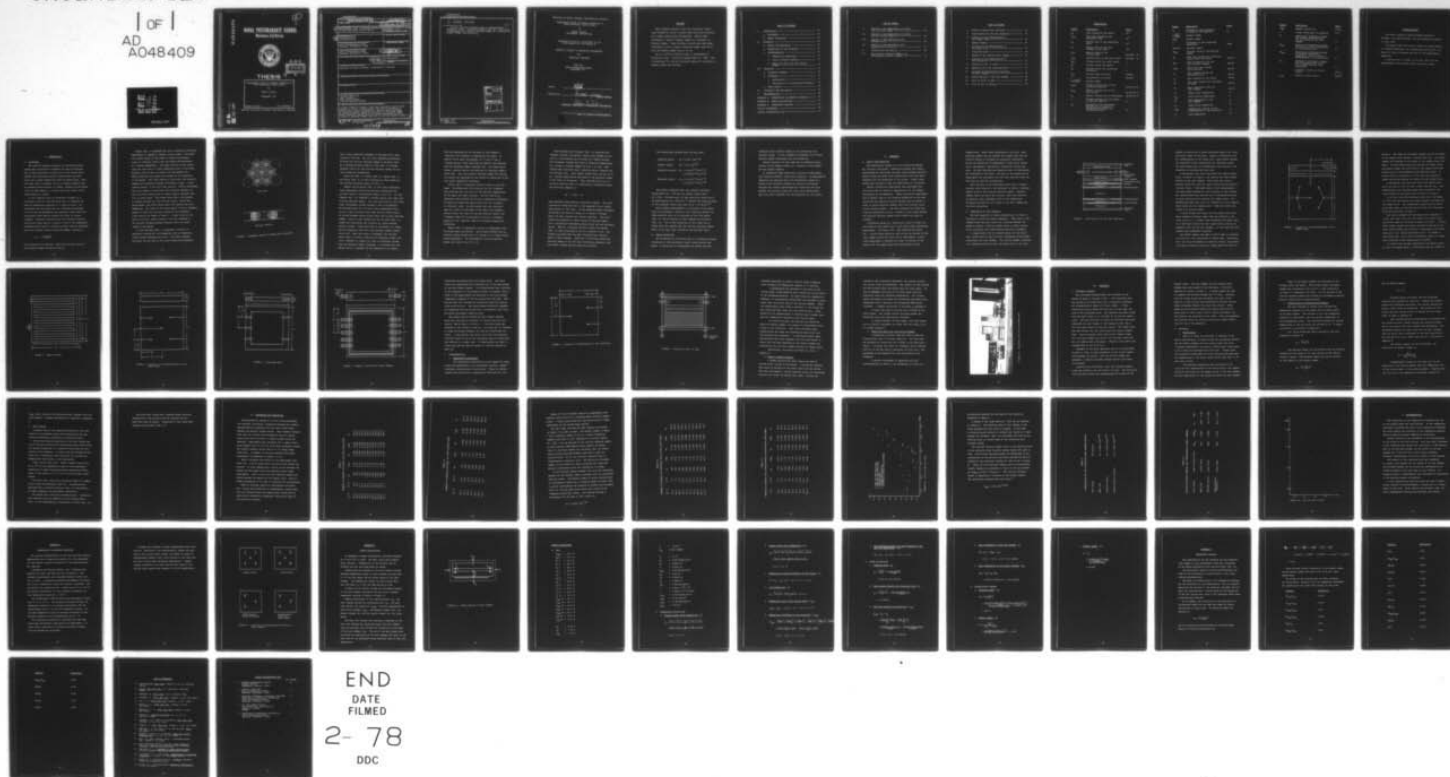

END
DATE
FILMED
2-78
DDC

AD A 0 4 8 4 0 9

(2)
SR

NAVAL POSTGRADUATE SCHOOL

Monterey, California



DDC
RECEIVED
JAN 17 1978
B

THESIS

EXPERIMENTAL STUDY OF NATURAL CONVECTION IN
THIN HORIZONTAL LIQUID LAYERS

by

Mahmut Yurteri

September 1977

Thesis Advisor:

M.D. Kelleher

Approved for public release; distribution unlimited.

AD No. _____
DDC FILE COPY

UNCLASSIFIED

SECURITY CLASSIFICATION OF THIS PAGE (When Data Entered)

REPORT DOCUMENTATION PAGE

READ INSTRUCTIONS BEFORE COMPLETING FORM

1. REPORT NUMBER	2. GOVT ACCESSION NO.	3. RECIPIENT'S CATALOG NUMBER
------------------	-----------------------	-------------------------------

⑨ Master's thesis

4. TITLE (and Subtitle)	5. TYPE OF REPORT & PERIOD COVERED
-------------------------	------------------------------------

⑥ Experimental Study of Natural Convection in Thin Horizontal Liquid Layers,

Engineer's Thesis; September 1977

7. AUTHOR	8. CONTRACT OR GRANT NUMBER(s)
-----------	--------------------------------

⑩ Mahmut Yurteri

9. PERFORMING ORGANIZATION NAME AND ADDRESS	10. PROGRAM ELEMENT, PROJECT, TASK AREA & WORK UNIT NUMBERS
---	---

Naval Postgraduate School
Monterey, California 93940 ✓

11. CONTROLLING OFFICE NAME AND ADDRESS	12. REPORT DATE
---	-----------------

Naval Postgraduate School
Monterey, California 93940

⑪ September 1977

14. MONITORING AGENCY NAME & ADDRESS (if different from Controlling Office)	15. SECURITY CLASS. (of this report)
---	--------------------------------------

⑫ 70 p.

13. NUMBER OF PAGES
70
15. SECURITY CLASS. (of this report)
Unclassified

16. DISTRIBUTION STATEMENT (of this Report)

Approved for public release; distribution unlimited.

17. DISTRIBUTION STATEMENT (of the abstract entered in Block 20, if different from Report)

18. SUPPLEMENTARY NOTES

19. KEY WORDS (Continue on reverse side if necessary and identify by block number)

Natural Convection
Heat Transfer
Thin Liquid Layers
Critical Rayleigh Number

20. ABSTRACT (Continue on reverse side if necessary and identify by block number)

→ Heat transfer through a very thin horizontal liquid layer bounded on top by a cooled glass plate and on bottom by a heated copper plate was measured. Results were correlated in terms of Nusselt number as a function of Rayleigh number. Three different liquids were used under conditions to give a range of Rayleigh number from 350 to 4100 and Prandtl number

UNCLASSIFIED

SECURITY CLASSIFICATION OF THIS PAGE (When Data Entered)

(20. ABSTRACT Continued)

→ from 34 to 477.

Up to a critical condition heat is transferred by conduction alone. Convection appears when $Ra = 1600 \pm 100$. A correlation for critical Rayleigh number as a function of Prandtl number was obtained.

+ a -

ACCESSION for		
NTIS	White Section	<input checked="" type="checkbox"/>
DDC	Buff Section	<input type="checkbox"/>
UNANNOUNCED		<input type="checkbox"/>
JUSTIFICATION _____		
BY _____		
DISTRIBUTION/AVAILABILITY CODES		
Dist.	AVAIL. and/or	SPECIAL
A		

DD Form 1473
1 Jan 73
S/N 0102-014-6601

UNCLASSIFIED

2 SECURITY CLASSIFICATION OF THIS PAGE (When Data Entered)

Approved for public release; distribution unlimited.

Experimental Study of Natural Convection in
Thin Horizontal Liquid Layers

by

Mahmut Yurteri
Lieutenant, Turkish Navy

Submitted in partial fulfillment of the
requirements for the degrees of

MASTER OF SCIENCE IN MECHANICAL ENGINEERING

and

MECHANICAL ENGINEER

from the

NAVAL POSTGRADUATE SCHOOL
September 1977

Author

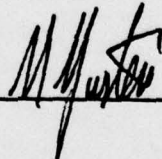

Approved by:

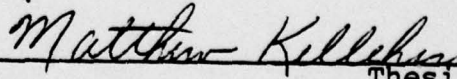

Thesis Advisor

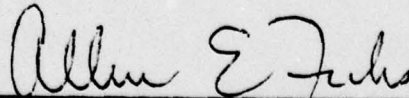

Chairman, Department of Mechanical Engineering

Dean of Science and Engineering

ABSTRACT

Heat transfer through a very thin horizontal liquid layer bounded on top by a cooled glass plate and on bottom by a heated copper plate was measured. Results were correlated in terms of Nusselt number as a function of Rayleigh number. Three different liquids were used under conditions to give a range of Rayleigh number from 350 to 4100 and Prandtl number from 34 to 477.

Up to a critical condition heat is transferred by conduction alone. Convection appears when $Ra = 1600 \pm 100$. A correlation for critical Rayleigh number as a function of Prandtl number was obtained.

TABLE OF CONTENTS

I.	INTRODUCTION -----	12
	A. BACKGROUND -----	12
	B. THESIS OBJECTIVES -----	18
II.	APPARATUS -----	20
	A. DESIGN CONSIDERATIONS -----	20
	B. DESCRIPTION OF THE APPARATUS -----	21
	C. INSTRUMENTATION -----	30
	1. Temperature Measurement -----	30
	2. Power to Heater Elements -----	33
	3. Water Flow Rate into the Cooling Chamber -----	34
III.	PROCEDURE -----	36
	A. APPARATUS ASSEMBLY -----	36
	B. PROCEDURE -----	37
	1. Measurements -----	37
	2. Determination of Dimensionless Numbers -	38
	C. TEST LIQUIDS -----	40
IV.	DISCUSSION AND CONCLUSIONS -----	42
V.	RECOMMENDATIONS -----	53
	APPENDIX A: THERMOCOUPLE CALIBRATION PROCEDURE -----	54
	APPENDIX B: SAMPLE CALCULATIONS -----	57
	APPENDIX C: UNCERTAINTY ANALYSIS -----	65
	LIST OF REFERENCES -----	69
	INITIAL DISTRIBUTION LIST -----	70

LIST OF TABLES

I.	Results of the Experiments with Mobil 603 with Plain Glass -----	43
II.	Results of the Experiments with Mobil 603 with Coated Glass -----	44
III.	Results of the Experiments with Ethylene Glycol -----	46
IV.	Results of the Experiments with Glycerol-Water Solution -----	47
V.	Correlations and Results -----	50
VI.	The Critical Rayleigh Numbers and Corresponding Prandtl Numbers -----	51

LIST OF FIGURES

1.	Sketch of Benard Cell Structure -----	14
2.	Cross Section of the Test Apparatus -----	22
3.	Location of the Thermocouples on the Copper Plate -----	24
4.	Heater Element -----	26
5.	Location of the Thermocouples on the Glass Plate -----	27
6.	Plexiglass Shim -----	28
7.	Spacer of the Cooling Water Chamber -----	29
8.	Location of the Thermocouples in the Insulation -----	31
9.	Location of the "U" Bars -----	32
10.	Apparatus with the Instrumentation -----	35
11.	Location of Thermocouples According to Their Numbers -----	56
12.	Energy Balance in the Test Chamber -----	58
13.	Plot of $\ln Nu$ vs $\ln Ra$ -----	48
14.	Plot of $\ln Pr$ vs $\ln Ra_{CR}$ -----	52

NOMENCLATURE

<u>Symbol</u>	<u>Description</u>	<u>Units</u>
A_B	Area covered by the heater	ft ²
A_{LIQ}	Test area bounded by the plexiglass shim	ft ²
A_P	Surface area of the plexiglass shim	ft ²
A_S	Surface area of the test chamber on the sides	ft ²
C_{CW}	Specific heat of the cooling water	Btu/lbm - °F
C_{LIQ}	Specific heat of the test liquid	Btu/lbm - °F
E_{GH}	Voltage across the guard heater	V
E_H	Voltage across the heater	V
E_R	Voltage across the calibrated resistance	V
F_{CW}	Cooling water flow rate	lbm/hr
g	Acceleration of gravity	ft/sec ²
$Gr = \frac{g\beta\Delta TL^3}{\nu^2}$	Grashof number	
k_{INS}	Thermal conductivity of the insulation material	Btu/hr-ft-°F
k_{LIQ}	Thermal conductivity of the test liquid	Btu/hr-ft-°F
k_P	Thermal conductivity of plexiglass	Btu/hr-ft-°F
L	Distance between the two plates of the test section	ft
L_B	Thickness of the insulation between the two groups of thermocouples between the insulation layers	ft

<u>Symbol</u>	<u>Description</u>	<u>Units</u>
L_S	Thickness of the insulation on sides of the apparatus	ft
$Nu = \frac{Q_T L}{k A \Delta T}$	Nusselt number	
$Pr = \frac{\nu}{\alpha}$	Prandtl number	
R	Resistance of the calibrated resistance	Ohms
$Ra = Gr Pr$	Rayleigh number	
Ra_{CR}	Critical value of the Rayleigh Number	
Q_B	Heat loss through the insulation layers below the heater	Btu/hr
Q_{CW}	Heat transferred into the cooling water chamber	Btu/hr
Q_{INS}	Total heat loss through the insulation	Btu/hr
Q_L	Heat leakage through the plexiglass shim	Btu/hr
Q_P	Heat supplied by the heater	Btu/hr
Q_S	Heat loss through the insulation on sides	Btu/hr
Q_T	Heat transferred into the test chamber	Btu/hr
T_C	Copper plate temperature	°F
T_{CW}	Cooling water temperature	°F
T_F	Film temperature of the test chamber	°F
T_G	Glass plate temperature	°F
T_{INS}	Temperature readings of the thermocouples in the insulation	°F
T_∞	Room temperature	°F

<u>Symbol</u>	<u>Description</u>	<u>Units</u>
$\alpha = \frac{k}{\rho C}$	Thermal diffusivity	ft ² /hr
β	Volume coefficient of expansion	1/°F
ΔT	Temperature difference between the average temperatures of the two plates of the test chamber	°F
ΔT_{CW}	Temperature difference between the inlet and exit temperatures of the cooling water	°F
ΔT_{INS}	Temperature difference between the average temperature readings of the two groups of thermocouples in the insulation	°F
ΔT_{∞}	Temperature difference between the film temperature of the test chamber and the room temperature	°F
ν	Kinematic viscosity of test liquid	ft ² /hr
ρ_{LIQ}	Density of test liquid	lbm/ft ³

ACKNOWLEDGMENTS

The author wishes to thank Professor Matthew D. Kelleher, his thesis advisor, for his guidance and advice in this study.

The author would also like to thank Mr. George Bixler, Mr. Kenneth Mothersell, Mr. Thomas Christian and Mr. Jim Selby for their assistance and work on the experimental apparatus.

A special word of thanks to my wife, Sara, for her understanding and patience during the entire study.

I. INTRODUCTION

A. BACKGROUND

The field of natural convection in enclosures encompasses many variations of geometry and input situations. One of these situations is heat flow in the narrow space between two horizontal parallel plates where the lower plate has a higher temperature than the upper plate. When the lower plate is heated, the fluid remains immobile and an unstable stratification is formed, inasmuch as the warmer fluid of lower density is located below the cooler fluid whose density is higher.

In his classical work on convection currents in a horizontal layer of fluid Rayleigh [Ref. 1] examined the case of temperature gradients in a layer of fluid. He formulated the flow equations for a discrete disturbance in the fluid and determined the conditions under which the disturbance would amplify causing the layer to become unstable. Rayleigh recognized that the unstable stratification must break down at a certain value of the temperature difference above which a convective motion must be generated. Below the critical value of Rayleigh number, defined as:

$$Ra = \frac{g \beta \Delta T L^3}{\alpha \nu}$$

pure conduction is observed. Above the critical value of the Rayleigh number convection begins.

Benard [Ref. 2] performed the first laboratory controlled experiments on thermally unstable liquid layers. He worked with liquid layers on the order of several millimeters, lying on a metallic plate which was heated and maintained at a uniform temperature. The upper surface of the liquid layer was free and at a lower temperature than at the plate surface, since it was in contact with the ambient air. Benard described the change from conduction to convection in two phases. The fluid remains at rest until the vertical temperature difference becomes sufficiently large. A preliminary motion of the fluid then results. Shortly thereafter, this first phase of relatively short duration appears, in which the fluid forms cells of nearly regular polygons with four to seven sides. This phase lasts from a few seconds to several minutes for more viscous fluids. During the second phase, the cells become equal and regular and align themselves. The limit of the second phase is thus a permanent regime of cells with vertical boundaries and hexagonal cross sections as shown in Figure 1. Liquid rises in the core of the cell, moves outward at the top, descends at the vertical boundary between adjacent cells and moves inward at the bottom.

In 1926 Jeffreys [Ref. 3] presented a solution to Rayleigh's problem for two boundaries with no tangential forces between boundary and fluid. His study included solutions for the case of two rigid conducting boundaries

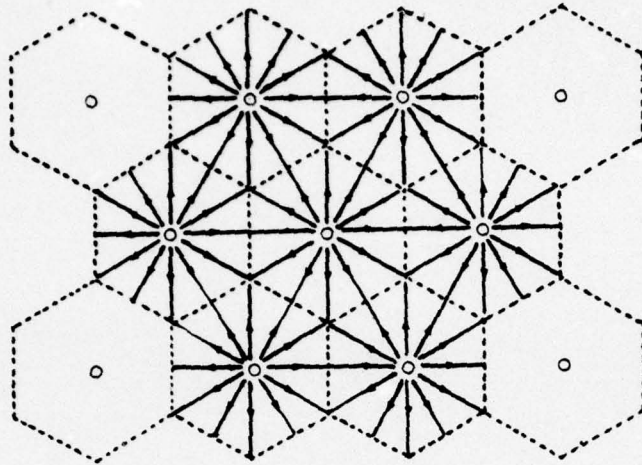

Plan View

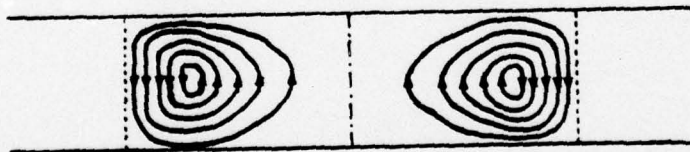

Vertical Section

FIGURE 1. Schematic Sketch of Benard Cell Structure

and a rigid conducting boundary at the base with a free surface at the top. For two rigid conducting boundaries he found the critical Rayleigh number to be about 1200. By a revised solution method in 1928 [Ref. 4] Jeffreys obtained 1709.5 for the critical Rayleigh number for two rigid conducting boundaries.

Later Low [Ref. 5], Sutton [Ref. 6], Malkus [Ref. 7] and Catton [Ref. 8] in their theoretical works agreed on the critical Rayleigh number of 1705 ± 5 .

Schmidt and Milverton [Ref. 9] with their admittedly rough experiments with distilled water determined the critical value of the Rayleigh number to be 1770. In 1938 Chandra [Ref. 10] observed a columnar motion well under the critical Rayleigh number. His test fluid was air with fluid layer thicknesses varying between 4 and 16 millimeters. He concluded that for all fluid layer thicknesses below 10 mm. a type of motion other than cellular motion which he called columnar motion occurs below the critical Rayleigh number. Later in 1952 DeGraaf and Van Der Held [Ref. 11] worked with horizontal and inclined air layers between parallel plates. They found that in horizontal air layers the air remains at rest until the Rayleigh number reaches about 2000. When this value is exceeded, the cellular motion sets in, first in the form of hexagonal prisms, but with a tendency to change into rows of tetragonal prisms when the Rayleigh number increases. In contrast with the Benard cells in liquids, the air descends in the middle.

This was explained by the increase of the kinematic viscosity with increase in temperature for gases. At smaller fluid layer thicknesses of 5.5 and 6.9 mm. a columnar motion, first described by Chandra, was observed when the Rayleigh number exceeded 1400. For these thicknesses, cellular motion was observed for Rayleigh numbers above 1600. This low critical Rayleigh number for thinner air layers was explained by the authors as being due to the very great temperature gradients.

Sutton [Ref. 6] explained previous works in his 1950 paper. He showed that the criterion for the "columnar" mode involves only the ratio of the absolute temperatures of the upper and lower surfaces. He also derived an expression and verified the critical temperature difference at which the transition takes place from the "columnar" to "cellular" mode. He also showed that the "cellular" mode will occur if the depth of the test fluid exceeds a certain value, but that for the more shallow layers, the "columnar" mode will be generated initially, ultimately passing to the "cellular" mode for increased temperature difference.

Malkus [Ref. 7] performed a series of experiments with distilled water and acetone. The distance between the two parallel plates ranged from 0.05 inches to 8.0 inches during these experiments. His experimental critical Rayleigh number was found to be 1700 ± 80 .

Ernst Schmidt and Silveston [Ref. 12] examined heat transfer through a horizontal liquid layer bounded on the top by a cold surface and on bottom by a heated surface. Five different liquids were used at different temperatures for a range in Prandtl numbers of from 3 to 4000. Test liquids were distilled water, ethylene glycol, heptane and two silicone oils. Layer depths ranged from 1.45 mm. to 13 mm. Optical observations were made on the patterns formed in the layer by convection. They concluded that up to a critical condition heat is transferred by conduction alone and convection appears at

$$Ra = 1700 \pm 3\%.$$

They observed three distinct convection regimes. The first occurred as convection sets in and appeared to be a honeycomb pattern in the layer. As the Rayleigh number increases, the pattern was found to change to a series of stripes where the heat transfer had laminar character. The third regime was observed at higher values of Rayleigh number with a tangled and disordered pattern which was the turbulent region. Results, including the data of Mull and Reiher [Ref. 13] were correlated by Nu as a function of Ra . The authors concluded that the data indicated four distinct modes of heat transfer. Above $Ra = 10,000$ they found that Rayleigh number is not the only correlating parameter, and the Prandtl number must be taken into account.

The correlations derived from the data were:

$$\text{Creeping region: } Nu = 0.0012 (Ra)^{0.90}$$

$$\text{Laminar region: } Nu = 0.24 (Ra)^{0.25}$$

$$\begin{aligned} \text{Transition region: } Nu &= 0.30 (Gr)^{0.16} (Pr)^{0.21} \\ &= 0.30 (Ra)^{0.16} (Pr)^{0.05} \end{aligned}$$

$$\begin{aligned} \text{Turbulent region: } Nu &= 0.10 (Gr)^{0.31} (Pr)^{0.36} \\ &= 0.10 (Ra)^{0.31} (Pr)^{0.05} \end{aligned}$$

The authors commented that the creeping convection begins about $Ra = 1700$ and the laminar region about $Ra = 3000$. Starting point of the transition region was to be determined by $Ra = 8000 (Pr)^{0.2}$ whereas the starting point of the turbulent region was given by $Ra = 18,000 (Pr)^{0.2}$

Heat transfer measurements in horizontal fluid layers seem to be generally lacking in the literature except for some extensive data on air obtained by Mull and Reiher [Ref. 13] and on liquids by Ernst Schmidt and Silveston [Ref. 12]. One of the objectives of this study was to obtain data for liquids near the critical Rayleigh number, which is the area least covered by the previous works.

B. THESIS OBJECTIVES

The objectives of this study were to investigate natural convection in thin horizontal liquid layers heated from below, in particular to investigate the change from the

conduction heat transfer regime to the convection heat transfer regime. It was intended to determine the critical Rayleigh number associated with the transition.

Another objective of the study was to determine correlations of the Nusselt number as a function of the Grashof and the Prandtl numbers.

To accomplish these objectives a series of experiments with several different fluids were conducted. An experimental apparatus was designed where the hypothetical system of a system fluid contained between two infinite, horizontal surfaces was closely approximated by containing the fluid between two parallel plates and using layer depths which were very small compared with the dimensions of the plates.

II. APPARATUS

A. DESIGN CONSIDERATIONS

The hypothetical system of a fluid contained between two infinite, horizontal, conducting surfaces was closely approximated by containing the test liquid between parallel square plates and using layer depths which were very small compared with the dimensions of the plates. Larger layer depths were avoided to keep the edge effects to a minimum.

Several preliminary experiments were performed with distilled water to obtain an appreciation for the general performance of the apparatus. These preliminary experiments gave a general idea of the required properties of the test liquid and the required distance between the two plates in order to obtain Rayleigh numbers about the critical value of the Rayleigh number. The data obtained from these preliminary experiments are not included in this study because the obtained Rayleigh numbers were outside the range of interest.

A petroleum based oil, commercially known as Mobil 603 was chosen as the second test liquid after these preliminary experiments. Two sets of data were obtained with Mobil 603. A plain glass plate was used as the top surface of the test chamber during the first set of experiments. During these experiments a problem with short circuiting of the heater with the copper plate was encountered at high

temperatures. After these experiments a very thin, heat resistant gasket was put between the copper plate and the electric heater to increase the electrical insulation. During the second set of experiments a glass plate coated with a transparent, electrically conductive coating was used. The data obtained from these two sets of experiments are contained in the study. The data of the second set of experiments was consistent with the data obtained later and this data is used for correlations.

With the help of the preliminary water data a characteristic plate spacing L , was selected to obtain a Rayleigh number close to the critical Rayleigh number. Rayleigh numbers above and below the critical value were obtained by changing other parameters such as the temperature difference between the two plates of the test chamber and the fluid properties.

B. DESCRIPTION OF THE APPARATUS

The test apparatus as shown schematically in Figure 2, consisted of three principal components. These were a test chamber where the test liquid was contained between two parallel plates, a cooling chamber above it where cooling water circulated and a guard heater/insulation assembly.

A copper plate with an attached heater at the bottom and a glass plate at the top with a plexiglass shim between constituted the test chamber. The cooling chamber consisted of a plexiglass plate on top, the glass plate of the test

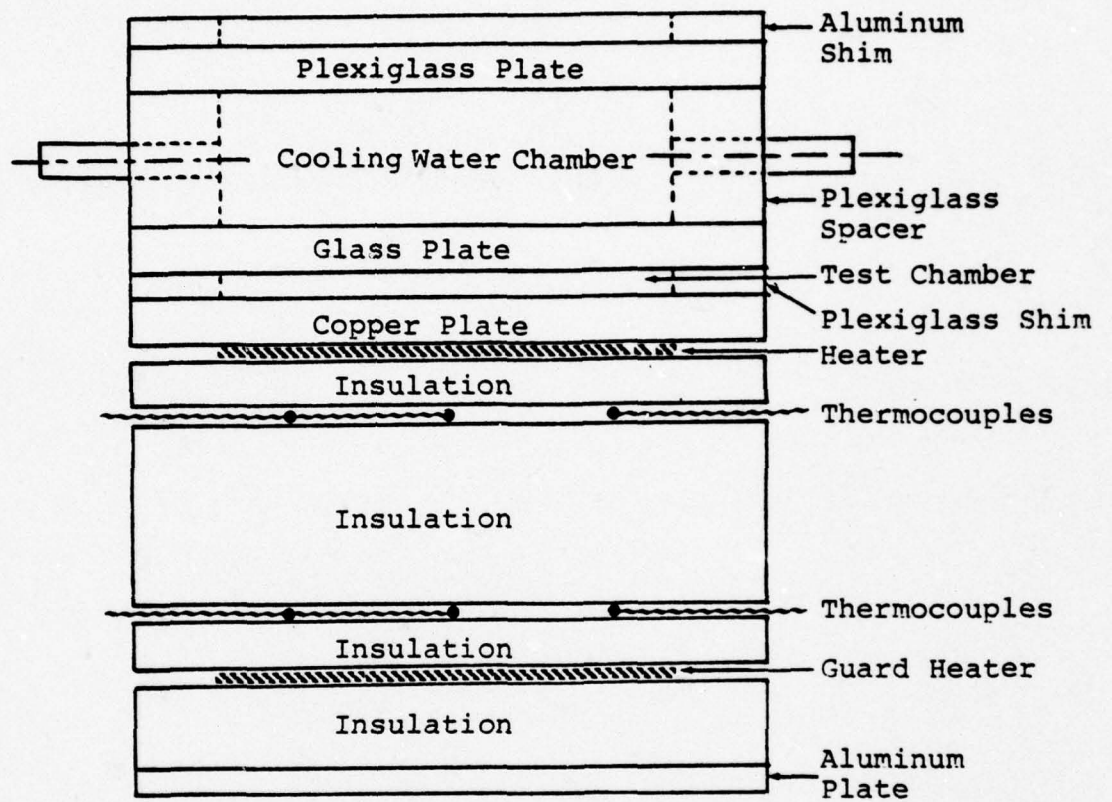

FIGURE 2. Cross Section of the Test Apparatus

chamber on bottom and a thick plexiglass spacer with inlet and outlet tubes on the sides. Layers of insulation with six thermocouples in two groups and a guard heater between the insulation layers constituted the insulation piece. The guard heater and the thermocouples were placed in the insulation to minimize the heat loss.

A one-quarter inch thick and seven inch square copper plate, as shown in Figure 3, was used as the lower heated surface of the test chamber. Both sides were given a machine finish and later the upper surface was polished to a mirror finish. Flattened beads of five thermocouples (30 gage copper-constantan) were attached on this surface. The thermocouples were painted with a nonconducting paint to avoid shortcircuiting through the copper plate. The thermocouple leads were taken out through 0.05 inch diameter holes bored into the copper plate. These two holes were sealed with silicon rubber.

A third channel was bored into the copper plate and a small diameter stainless steel tube was soldered to the outer end of it. A plastic tube connected this metal tube to a container filled with test liquid which acted as an expansion tank for the test chamber. It also kept the test chamber near atmospheric pressure.

The heater element was made of twelve feet of nichrome wire having a total resistance of twelve ohms. The twelve foot long wire was shaped into parallel strips, one-quarter inch apart covering an area six inches square as shown in

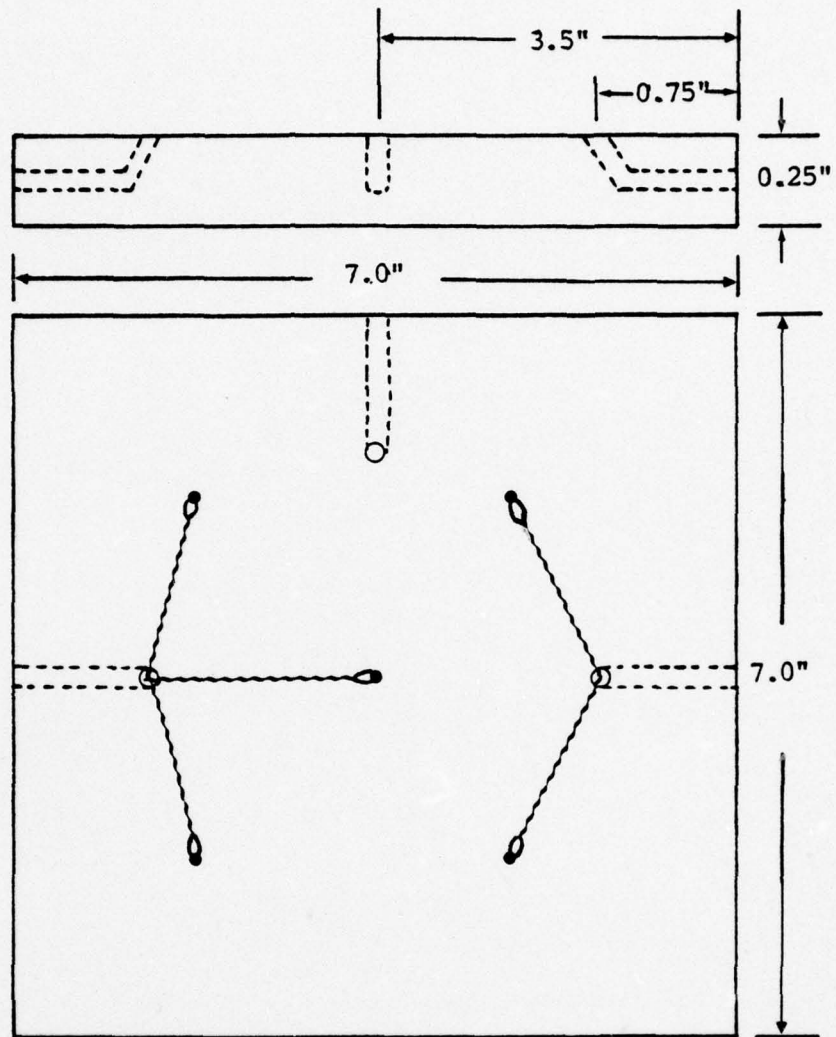

FIGURE 3. Location of the Thermocouples on the Copper Plate

Figure 4. The shape of the heater element and the thickness of the copper plate insured a uniform heat flux. The heater element was attached to the bottom of the copper plate with epoxy. To avoid shortcircuiting through the copper plate, the heater element and the bottom of the copper plate were painted with a high temperature nonconducting paint. To insure electric insulation, a 0.010 inch heat resistant gasket was placed between the heater and the copper plate.

A one-quarter inch thick and seven inch square glass plate was used to cool the test liquid from the top. Five thermocouples with flattened beads were attached on the lower surface of the glass plate as shown in Figure 5.

A one half inch wide plexiglass shim with a thickness of 0.125 inch was used as the spacer between the glass and the copper plate. The thermocouple leads from the glass plate were taken out through holes drilled into the plexiglass shim as shown in Figure 6.

The cooling chamber for the upper plate consisted of a half inch wide, one inch thick spacer with water inlet and outlet tubes on two sides as shown in Figure 7. Cooling water flowed through this space, bounded on bottom by the glass cooling plate and on top by a one-quarter inch thick and seven inch square plexiglass plate. To insure a watertight seal, two 0.0625 inch Neoprene rubber "O" rings were installed at each spacer-plate interface.

To insure that the heat generated by the heater would go into the copper plate, a guard heater and two inches of

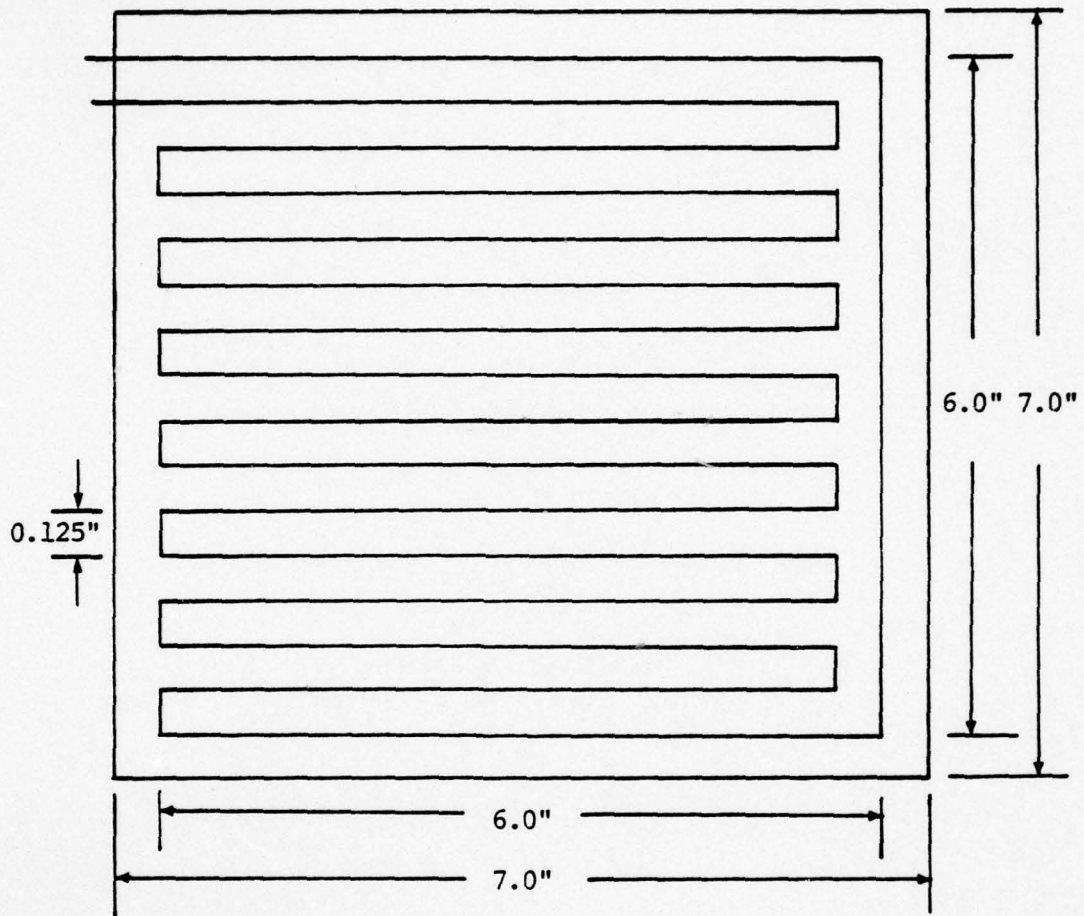

FIGURE 4. Heater Element

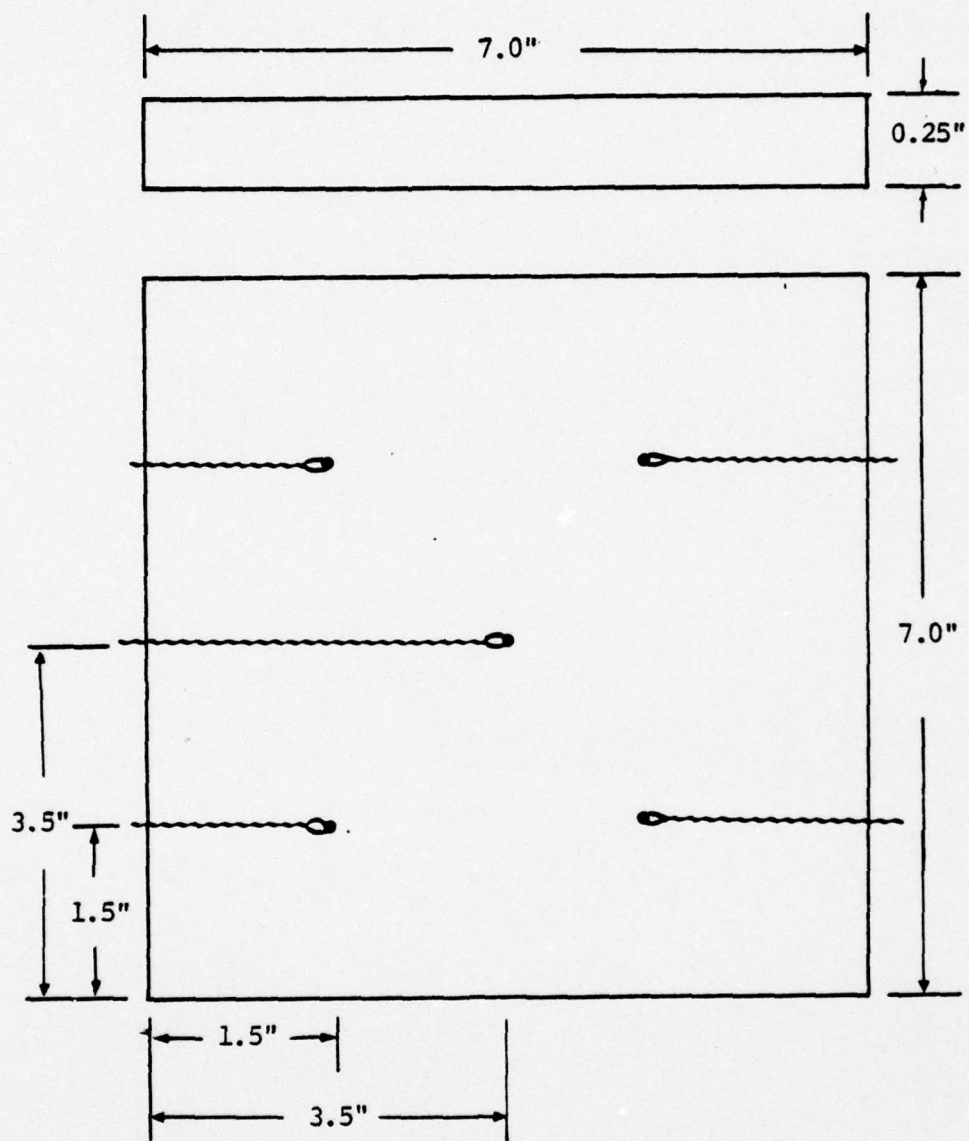

FIGURE 5. Location of the Thermocouples on the Glass Plate

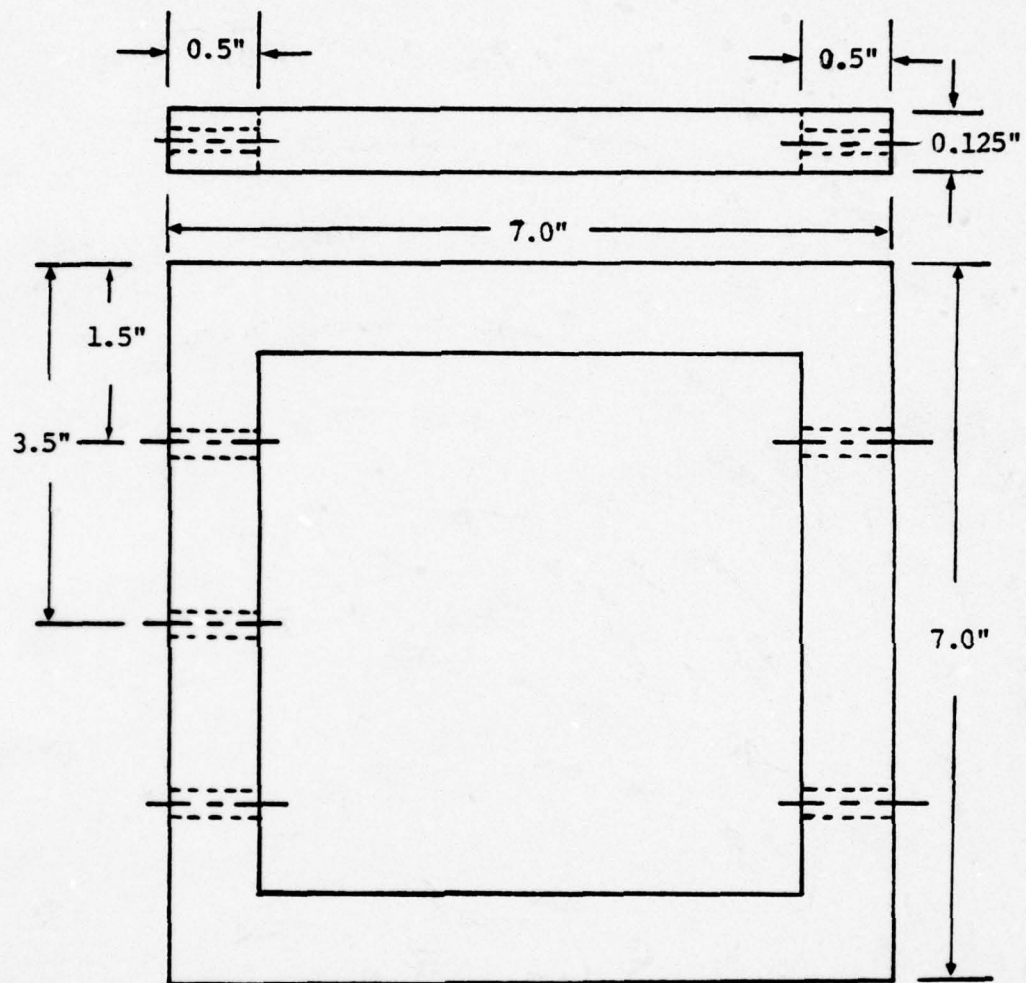

FIGURE 6. Plexiglass Shim

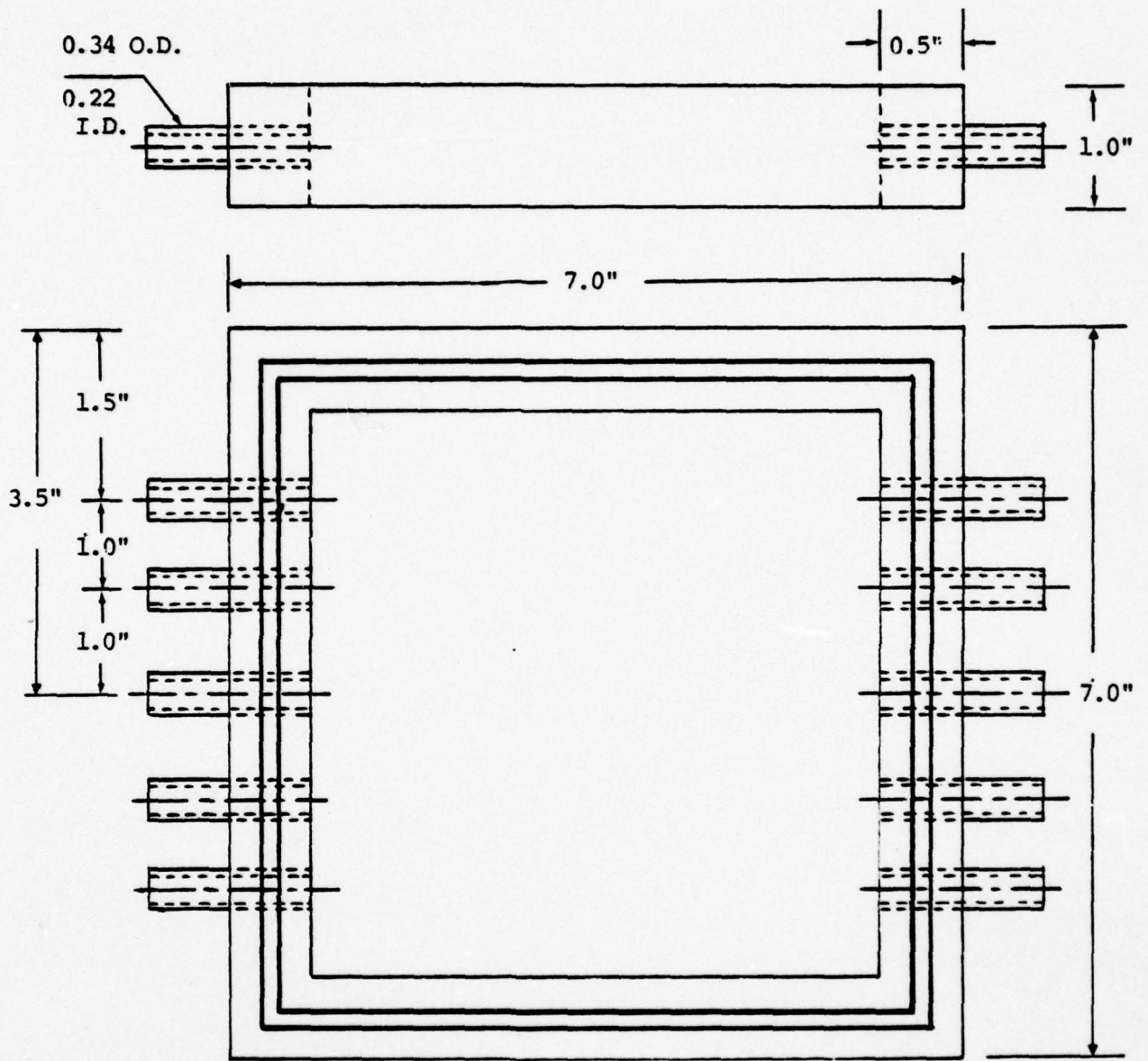

FIGURE 7. Spacer of the Cooling Water Chamber

insulation was placed below the copper plate. The guard heater was constructed from nichrome wire in the same manner as the main heater element. Six thermocouples were installed in the insulation in two groups as shown in Figures 1 and 8. Power to the guard heater was adjusted so that the average temperature readings of the two groups were the same. Then the net heat loss through the insulation below the heating plate would be zero. This guard heater/insulation assembly was supported from the bottom with a one-quarter inch thick and seven inch square aluminum plate.

The plates and the insulation were clamped together using four sections of aluminum "U" channel and four connecting rods as shown in Figure 9. A leveling screw was attached to the bottom of each rod. By using the "U" channels to clamp the system together the load was distributed uniformly. A one-quarter inch thick, half inch wide aluminum shim was placed on top of the plexiglass plate to distribute the loading to a larger area. A torque wrench was used to insure the same and desired amount of load was applied on each rod.

C. INSTRUMENTATION

1. Temperature Measurement

The temperature distribution on the copper and glass plates was determined by five ungrounded junction, copper-constantan thermocouples on each plate. These ten thermocouples were wired into a thermocouple switching box, and

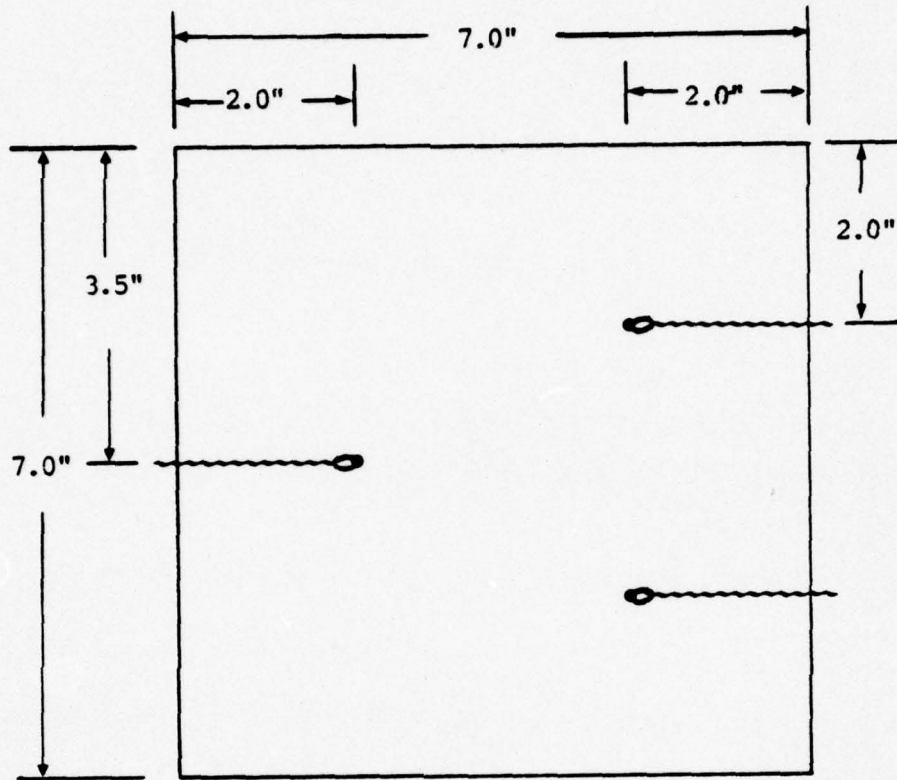

FIGURE 8. Location of Thermocouples in the Insulation

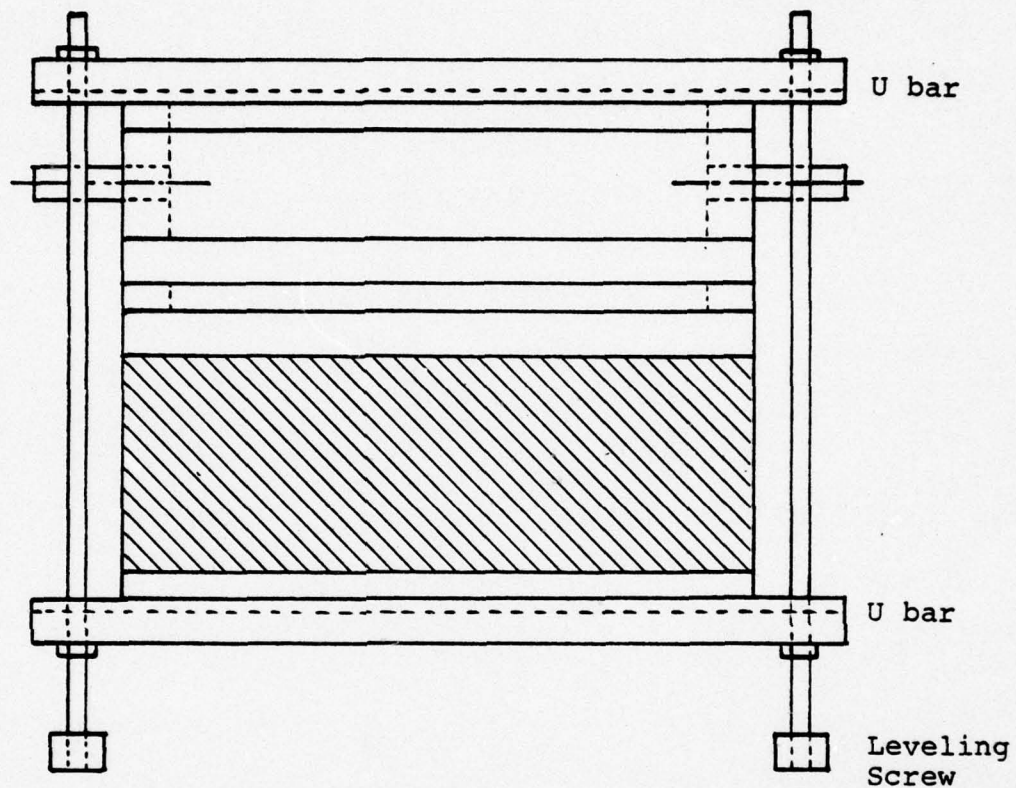

FIGURE 9. Location of the "U" Bars

recorded separately by using a digital readout Numatron which displays the temperature reading in °F directly.

A thermocouple was attached to the inlet of the cooling water intake manifold and a second one to the outlet of the discharge manifold. To check these two temperature readings, an uncalibrated thermocouple was attached to every water inlet and outlet tube of the cooling chamber. These ten thermocouples were wired in parallel in two groups and each group was then wired into the switching box. These groups of five thermocouples in parallel gave average inlet and exit temperature readings of the cooling water.

To control the heat loss through the insulation below the heater element, two groups of thermocouples were placed in the insulation. Each group contained three thermocouples and these six thermocouples were wired into the switching box separately. As mentioned before these thermocouples were used together with the guard heater to insure that the heat generated by the heater element was transferred into the test chamber through the copper plate.

Thermocouple calibration procedure is given in Appendix A.

2. Power to Heater Elements

A Lambda regulated DC power supply was used to provide input voltage to the heater. A calibrated resistor was placed in series with the power supply and the heater. With this arrangement, voltage readings across the calibrated resistor and across the heater were taken. Knowing the

voltage of the calibrated resistance, the current through the circuit could be determined. The product of this current and the voltage across the heater gave the input power. By this arrangement the value of the input power could be accurately reset for different experiments. The voltage across the heater and across the calibrated resistance were determined using a Keithley 168 Autoranging DMM digital voltmeter. A sample calculation is provided in Appendix B.

A variac was used to provide input voltage to the guard heater. The voltage across the guard heater was determined using the same digital voltmeter.

To ensure constant voltage supply, the input power for all electric equipment was taken from the output of an AC voltage regulator.

3. Water Flow Rate into the Cooling Chamber

A submersible electric pump was used to pump the cooling water from a 25 gallon reservoir. The flow rate was adjusted by controlling the voltage to the pump with a variac. A Fischer and Porter Co. flowmeter with a maximum rate of 0.6 GPM was used to determine the flow rate. The percentage of the maximum flow rate was marked on the flowmeter.

A general arrangement of apparatus with the instrumentation is shown in the photograph in Figure 10.

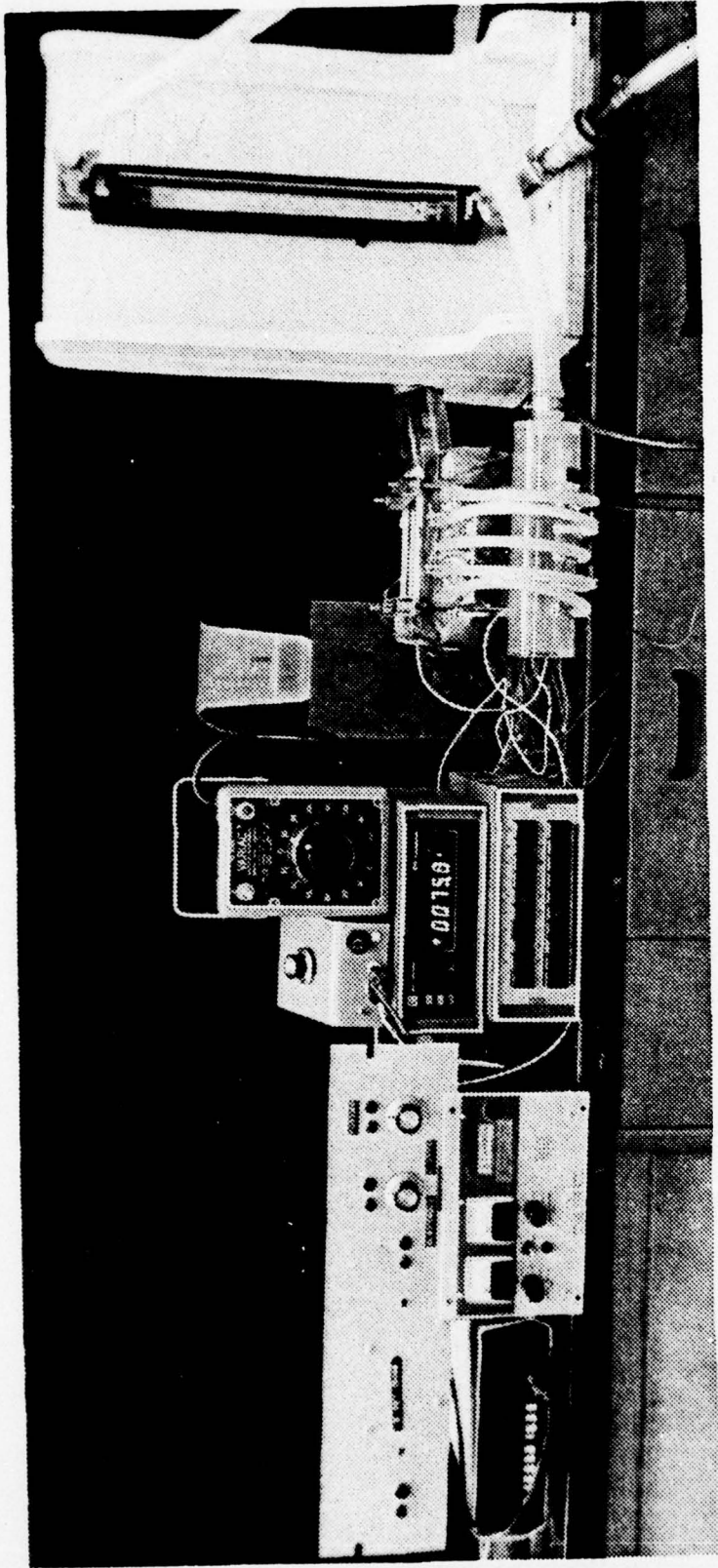

FIGURE 10. Apparatus with the Instrumentation

III. PROCEDURE

A. APPARATUS ASSEMBLY

The calibrated thermocouples were attached to the plates as shown in Figures 2 and 4. The plexiglass shim was placed on the glass plate and a watertight interface was accomplished by means of silicon rubber. A thick continuous silicon rubber film was laid on the upper surface of the plexiglass shim. The apparatus was then filled with the test liquid up to the edge of the silicon rubber layer. The next step was to attach the overflow tube which connected the test chamber to the expansion tank and to fill the whole tube with the test liquid. The copper plate was then placed over the glass plate and lightly pressed down. Once the excess liquid and silicon rubber flowed out, the test chamber was filled with the test liquid and all air bubbles were eliminated. Generally this result was accomplished by the third try.

Assembly of the whole apparatus had to be accomplished quickly in order to avoid hardening of the silicon rubber film between the plates. Once the silicon rubber had hardened, a uniform thickness between plates could never be attained.

Starting from the bottom, first the aluminum support plate was placed on the two bottom "U" bars. The insulation with the guard heater and thermocouples was placed on the

support plate. The test chamber and the cooling water chamber were then placed on the insulation. The whole apparatus is shown in Figure 1. A torque wrench was used to compress the sections between the "U" bars. Starting with low torque values and increasing the load a foot-pound at a time an even load distribution and even silicon rubber thickness between the plates was insured. After measuring the distance between the copper plate and the glass plate at each corner with an inside micrometer, the test section was insulated on the sides. Later the apparatus was levelled using the leveling screws and a small bubble level on top of the apparatus.

B. PROCEDURE

1. Measurements

Data of a usual run consisted of readings of the twenty thermocouples, voltages across the calibrated resistor and the heater elements and the cooling water flow rate. A complete experimental run usually lasted about three hours. A set of data was recorded every half hour. Steady state was considered established and final readings were made when the temperatures in the whole system varied less than 0.2 °F over half an hour.

The recorded temperature data consisted of the inlet and exit temperatures of the cooling water, the temperatures of the glass and the copper plates in the test chamber and the temperatures in the insulation below the test chamber.

Power to the heater element was monitored by the voltage across the heater. The voltage across the heater element was increased by two volts at a time starting at 10 volts, to a maximum of 25 volts. In the vicinity of the critical Rayleigh number the voltage was increased by smaller steps to obtain data at desired points.

2. Determination of Dimensionless Numbers

The data recorded at steady state included ten temperature readings for the copper and the glass plates of the test chamber. The average of the five temperature readings for each plate, gave the average temperature of the corresponding plate. The difference between the average temperatures of the two plates was defined as ΔT . A sample calculation is contained in Appendix B.

All liquid properties were evaluated at the film temperature defined as

$$T_F = \frac{T_C + T_G}{2}$$

The Rayleigh number was calculated using the distance between the two plates of the test section as the characteristic length. The Rayleigh number also can be written as the product of the Grashof number:

$$Gr = \frac{g \beta \Delta T L^3}{\nu^2}$$

and the Prandtl number:

$$\text{Pr} = \frac{\nu}{\alpha} .$$

Voltages across the heater and the calibrated resistor were recorded for each run. Knowing the voltage across the calibrated resistance, the current through the heater circuit could be determined. The product of this current and the voltage across the heater gave the input power as shown in Appendix B.

Heat leakage through the plexiglass shim between the two plates and heat leakage through the insulation below and on the sides of the test chamber were determined. The difference between the input power and the heat leakages gave the actual heat transferred to the test liquid which was defined as Q_T and a sample calculation is contained in Appendix B.

The Nusselt number was then calculated. By definition the Nusselt number is:

$$\text{Nu} = \frac{Q_T L}{A_{\text{LIQ}} \Delta T k_{\text{LIQ}}}$$

Thermocouples located at the inlet and the exit manifolds of the cooling chamber gave the temperature rise of the cooling water in the cooling chamber. Together with the flow rate, this temperature difference, defined as

ΔT_{CW} , gave a check on the calculated heat transfer into the test chamber. A sample calculation is contained in Appendix B.

C. TEST LIQUIDS

A general idea of the required properties of the test liquid for the present design was obtained from the preliminary experiments conducted with distilled water.

Finding the desired properties of the test liquids was one of the major difficulties encountered during this study. All desired properties of a selected liquid were not contained in one reference. In some cases the properties were given for a temperature range which did not include the temperatures encountered in the experiments.

Three liquids were used. Prandtl numbers varied from 34 to 476 for the temperature range of the experiments. Properties of these liquids permitted temperature differences in the range of 4 °F to 33 °F with very small layer depths.

The first test liquid was a petroleum based oil commercially known as Mobiltherm light 603. Properties were obtained from a technical bulletin [Ref. 14] published by the Mobil Research and Development Corporation.

The second test liquid was ethylene glycol. Properties were obtained from the Handbook of Heat Transfer Media [Ref. 15] and Thermophysical Properties of Matter [Ref. 16].

The third test liquid was a glycerol-water solution. Composition of the solution was 56% glycerol and 44% distilled water by weight. Properties of the liquid were obtained from Glycerol [Ref. 17].

IV. DISCUSSION AND CONCLUSIONS

The hypothetical system of a fluid contained between two infinite, horizontal, conducting surfaces was closely approximated by containing the very thin liquid layer between two parallel square plates. Heat transfer through this very thin liquid layer bounded on top by a cooled glass plate and on bottom by a heated copper plate was measured. Experiments were conducted for a range of Rayleigh numbers from 350 to 4100 with three different liquids. The Prandtl numbers varied from 34 to 477 under these conditions. A summary of the data obtained from these experiments is presented in Tables I to IV.

Table I contains the results of the experiments with Mobil 603. A plain glass plate was used as the cooled top surface. At high temperatures a short circuit between the heater and the copper plate was observed during these experiments. Later a very thin heat resistant gasket was placed between the heater and the copper plate. Data of these experiments is not used in obtaining the correlations.

Table II contains results of experiments with Mobil 603. During this second set of experiments a glass plate with its surface facing the copper plate coated with an electrically conducting transparent coating was used as the cooled top surface.

TABLE I
 SUMMARY OF RESULTS FOR MOBIL 603 WITH PLAIN GLASS

T_F °F	ΔT °F	Ra	LnRa	Nu	LnNu	Pr
78.6	9.0	399	5.99	1.089	0.086	476.5
80.0	9.8	443	6.09	1.089	0.085	448.5
82.2	11.7	577	6.36	1.049	0.048	431.2
84.3	13.7	714	6.57	1.033	0.036	411.5
90.0	18.7	1129	7.03	0.978	-0.023	361.2
95.3	24.1	1158	7.41	0.978	-0.022	318.3
99.2	25.9	1179	7.48	0.974	-0.026	293.7
101.6	26.5	1943	7.57	1.005	0.005	279.0
101.1	28.1	2034	7.62	1.076	0.073	281.9
103.4	29.8	2272	7.73	1.187	0.172	268.5
108.7	30.9	2649	7.88	1.355	0.304	242.0
113.6	33.6	3201	8.07	1.567	0.449	220.2

TABLE II
 SUMMARY OF RESULTS FOR MOBIL 603 WITH COATED GLASS

T _F °F	ΔT °F	Ra	LnRa	Nu	LnNu	Pr
88.5	15.6	933	6.84	0.946	-0.055	374.0
92.4	19.0	1260	7.14	0.977	-0.023	341.4
95.8	22.0	1585	7.37	0.937	-0.065	316.1
97.4	23.5	1758	7.47	1.003	0.003	304.7
101.2	26.4	2167	7.68	1.186	0.171	281.2
106.2	29.5	2707	7.90	1.413	0.345	253.7
110.7	32.2	3184	8.07	1.599	0.469	232.5

Tables III and IV present results of experiments with ethylene glycol and 56 wt % glycerol-water solution respectively. A plain glass plate was used during both of these experiments as the cooled upper surface.

The data under the LnRa and LnNu columns are plotted in Figure 13 as LnNu vs LnRa . The Nusselt number is about 1 from a Rayleigh number of 350 to a range of Rayleigh numbers from 1500 to 1700, depending on the test liquid. $\text{Ra} = 1600 \pm 100$ was defined as the critical Rayleigh number. In their earlier experimental works Schmidt and Reihner [Ref. 9] and Ernst Schmidt and Silveston [Ref. 12] determined critical Rayleigh numbers from 1600 to 1800 for various fluids. Up to this critical condition heat is transferred by conduction only. The deviation of Nusselt number in the conduction regime increases for lower temperature differences where the uncertainty is higher.

At the Rayleigh numbers between 1500 and 1700 convection appears and the Nusselt number increases with the increasing Rayleigh number. The Nusselt number is nearly proportional to the Rayleigh numbers up to Rayleigh number of about 3000. A similar relationship was observed by Schmidt and Silveston [Ref. 12] for the same region which they called as the "creeping convection" region. The authors obtained a correlation for the data in this region as:

$$\text{Nu} = 0.0012 (\text{Ra})^{0.90}$$

TABLE III
 SUMMARY OF RESULTS FOR ETHYLENE GLYCOL WITH PLAIN GLASS

T_F °F	ΔT °F	Ra	LnRa	Nu	LnNu	Pr
78.0	5.1	398	5.99	1.155	0.144	160.0
80.9	7.2	602	6.40	1.124	0.117	150.6
85.7	9.9	854	6.75	1.082	0.079	136.6
89.2	12.9	1281	7.16	1.070	0.068	127.1
90.3	14.3	1448	7.28	1.087	0.084	124.5
93.3	15.3	1647	7.41	1.166	0.154	117.3
95.8	17.6	1994	7.60	1.320	0.278	113.3
100.5	19.4	2420	7.79	1.440	0.364	101.2
107.2	21.8	3101	8.04	1.727	0.546	89.8
111.5	21.2	3860	8.26	1.804	0.590	82.7

TABLE IV
SUMMARY OF RESULTS FOR GLYCEROL-WATER SOLUTION WITH PLAIN GLASS

T °F	ΔT °F	Ra	LnRa	Nu	LnNu	Pr
78.3	4.1	736	6.60	1.172	0.159	53.9
81.4	5.4	1017	6.93	1.223	0.202	50.9
84.5	7.1	1430	7.27	1.211	0.192	47.6
84.5	7.8	1589	7.37	1.220	0.199	47.7
86.9	8.3	1770	7.48	1.361	0.308	45.6
90.0	9.5	2133	7.67	1.529	0.425	42.9
92.5	10.8	2558	7.85	1.721	0.543	41.0
96.5	12.5	3154	8.06	1.861	0.621	38.1
102.0	14.2	3951	8.28	2.030	0.708	34.2

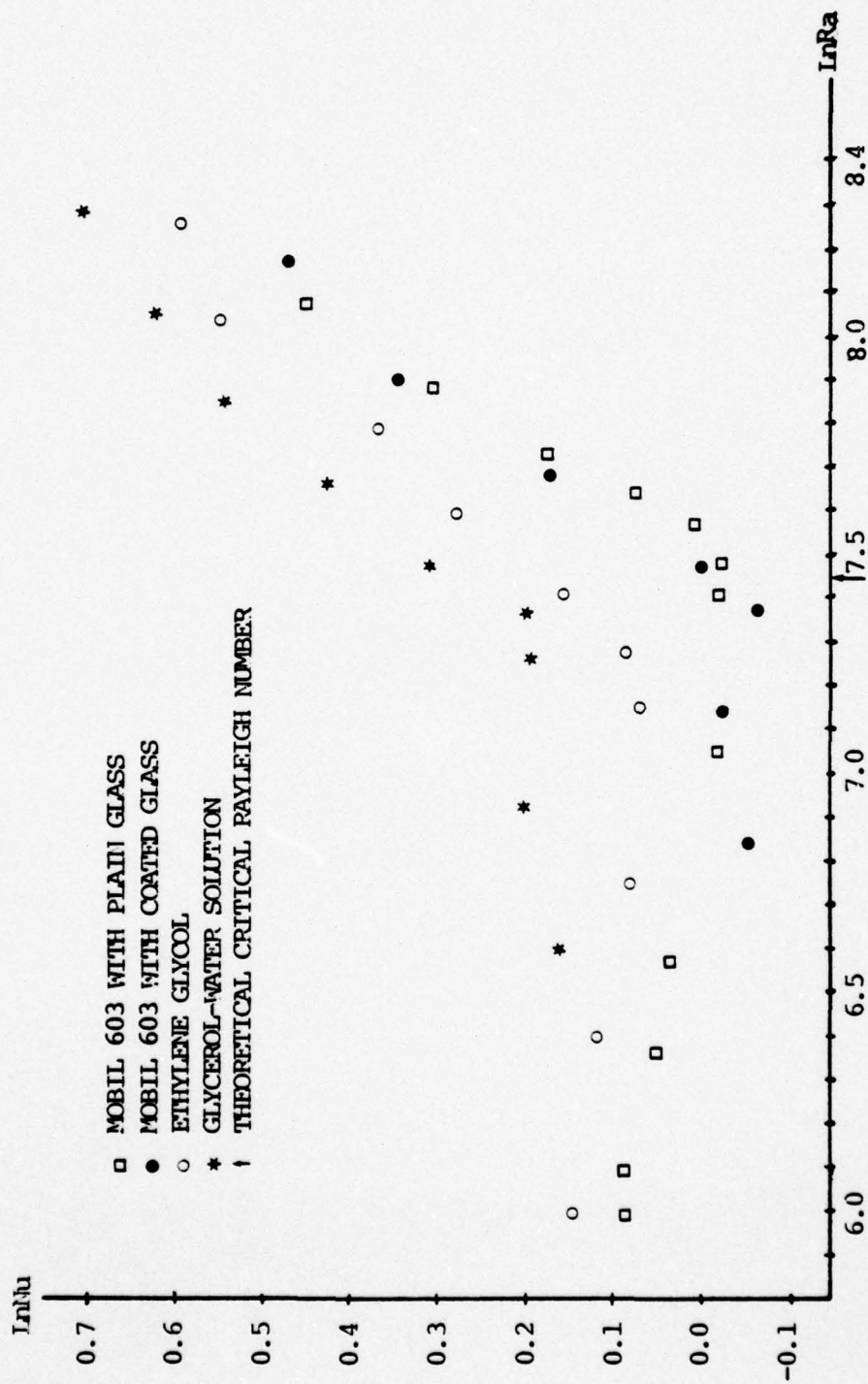

FIGURE 13. Plot of lnNu vs. lnRa

Correlations obtained for the data of this study are presented in Table V.

A change in the slope above $Ra = 3000$ can be observed in Figure 13. The starting point of this change in the slope differed from one fluid to another. In the case of Glycerol-water solution it started well below $Ra = 3000$. Schmidt and Silveston [Ref. 12] concluded that this is the starting point of another mode of the convection heat transfer regime.

The critical Rayleigh number which is the starting point of the convection heat transfer regime ranged from 1480 to 1702. The critical Rayleigh number was determined by the intersection of the paired lines drawn through the data of conduction and convection regimes for each fluid in Figure 13. These critical Rayleigh numbers and the corresponding Prandtl numbers are presented in Table VI and are plotted as $\ln Ra_{CR}$ vs $\ln Pr$ in Figure 14. The critical Rayleigh number is apparently a function of the Prandtl number. The correlation obtained from this data is

$$Ra_{CR} = 1103 (Pr)^{0.0760}$$

TABLE V
CORRELATIONS FOR THE CONVECTION HEAT TRANSFER REGIME

Test Liquid	Correlation
Mobil 603	$Nu = 0.0025 (Ra)^{0.80}$
Ethylene Glycol	$Nu = 0.0138 (Ra)^{0.60}$
Glycerol-Water Solution	$Nu = 0.0115 (Ra)^{0.64}$

TABLE VI
 CRITICAL RAYLEIGH NUMBERS AND CORRESPONDING PRANDTL NUMBERS

Test Liquid	Type of Glass Plate	Ra_{CR}	$LnRa_{CR}$	Pr	$LnPr$
Mobil 603	Coated Glass	1702	7.4396	300.0	5.704
Ethylene Glycol	Plain Glass	1480	7.2998	47.74	3.866
Glycerol-Water Solution	Plain Glass	1588	7.3702	123.0	4.812

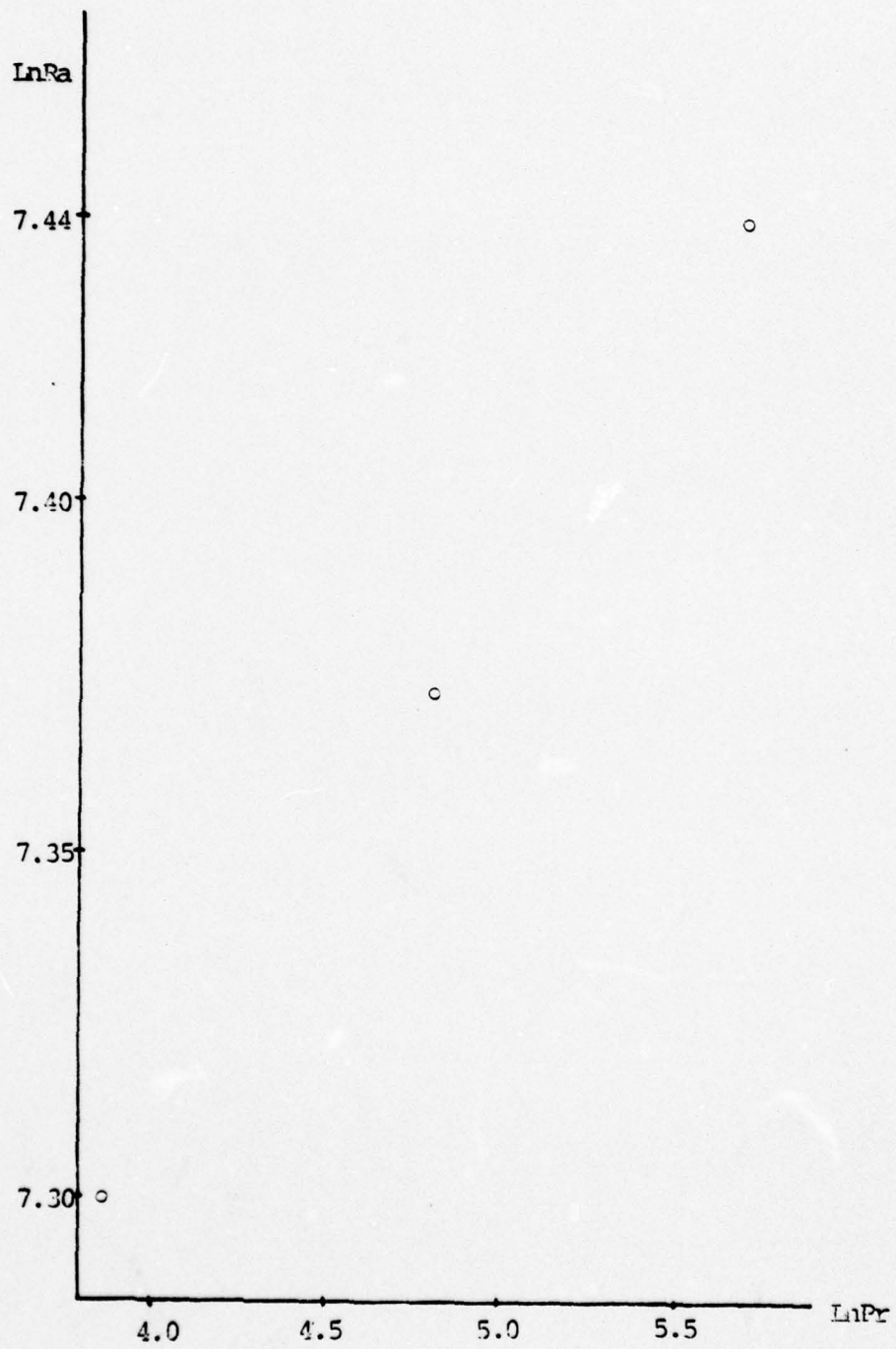

FIGURE 14. Plot of LnRa vs LnPr

V. RECOMMENDATIONS

The uncertainty in the temperature difference was one of the biggest among the uncertainties. As the temperature difference increases the size of this uncertainty decreases. One could improve the precision of the temperature measurements by employing higher temperature differences.

Another difficulty was attachment of the thermocouples to the plates of the test section. Even very small thickness of the flattened bead causes high uncertainty in the measurement of the distance between the two plates of the test chamber due to the very thin liquid layer thickness. Intrinsic thermocouples could be an answer to this problem.

The corners of the plexiglass shim were chamfered to create a gap between the two plates of the test chamber. The distance between the two plates was determined by an inside micrometer from these gaps at four corners. Increasing number of measurements could decrease the uncertainty of the Rayleigh number calculations.

A flow visualization technique could be used to demonstrate visually the establishment of convection in a future study in this area. Ernst Schmidt and Silveston [Ref. 12] used a shadowgraph technique and obtained good results.

APPENDIX A

THERMOCOUPLE CALIBRATION PROCEDURE

The accurate determination of the fluid and test section temperatures was an absolute necessity for this experiment. For this reason, precise calibration of the thermocouples was required.

A Rosemount Calibration System, with a constant temperature oil bath, was used for the calibration. The eighteen thermocouples were suspended several inches into the oil bath. A Platinum Resistance Thermometer in conjunction with a commutation bridge was used as a standard. The calibration was conducted over a range from 70 °F to 150 °F. The maximum uncertainty for the standard thermometer for this temperature range was ± 0.005 °F.

The thermocouple readings during the experiments ranged from 74 °F to 130 °F. The maximum difference between the temperature reading of the standard thermometer and the thermocouples was 0.9 °F for this temperature range. For the same temperature range the maximum difference in temperature readings of the thermocouples was 0.1 °F.

The calibration process was performed with the same switch-box and Numatron used during the experiments. In other words, there was no recording instrument changes once the system was calibrated.

A number was attached to every thermocouple after calibration. Positions of the thermocouples, except the ones used in the cooling water system, are shown in Figure 10. Thermocouples number 8 and 2 were located in the inlet and the exit cooling water manifolds respectively. Thermocouples attached to the inlet and the exit tubes of the cooling water spacer were numbered 19 and 20 respectively.

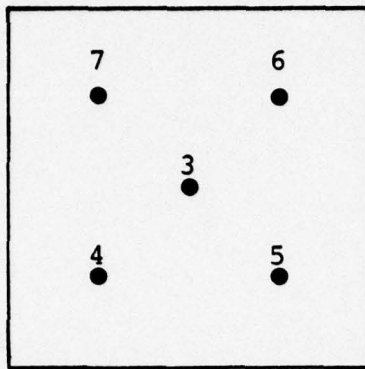

Copper Plate

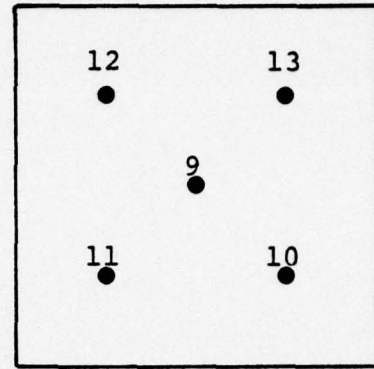

Glass Plate

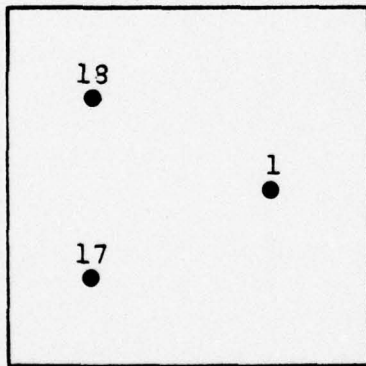

Thermocouples
Below the Heater

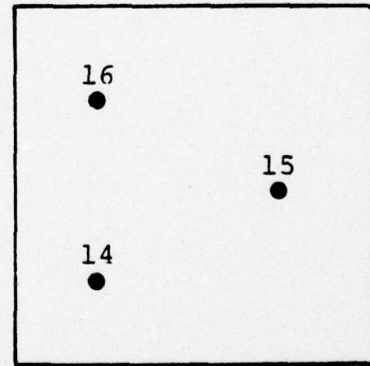

Thermocouples
Above the
Guard Heater

FIGURE 11. Location of Thermocouples According to Their Numbers

APPENDIX B

SAMPLE CALCULATIONS

To represent a sample calculation, the data recorded on 23 July 1977 is used. The test liquid was glycerol-water solution. Composition of the solution was 56% glycerol and 44% distilled water by weight.

Steady state was reached in two hours twenty minutes. Maximum temperature change in fifty minutes was less than 0.2 °F for the copper and the glass plates of the test chamber. The temperature change for the cooling water was less than 0.1 °F for the same period of time.

A sketch of the control volume for the energy balance on the test chamber indicating the major heat transfer components involved is shown in Figure 12.

Sample calculations of the supplied power (Q_p), the heat leakage through the plexiglass shim (Q_L), the heat loss through the insulation (Q_{INS}), the heat transferred to the cooling chamber (Q_{CW}), the Rayleigh number (Ra), the Nusselt number (Nu) and the Prandtl number (Pr) are given below.

The heat loss through the insulation consisted of the heat loss through the insulation below the test chamber (Q_B) and the heat loss through the insulation on the sides of the test chamber (Q_S). The sum of the heat losses from the sides for each plate of the test chamber was equal to the heat loss for an equivalent cross sectional area at the film temperature.

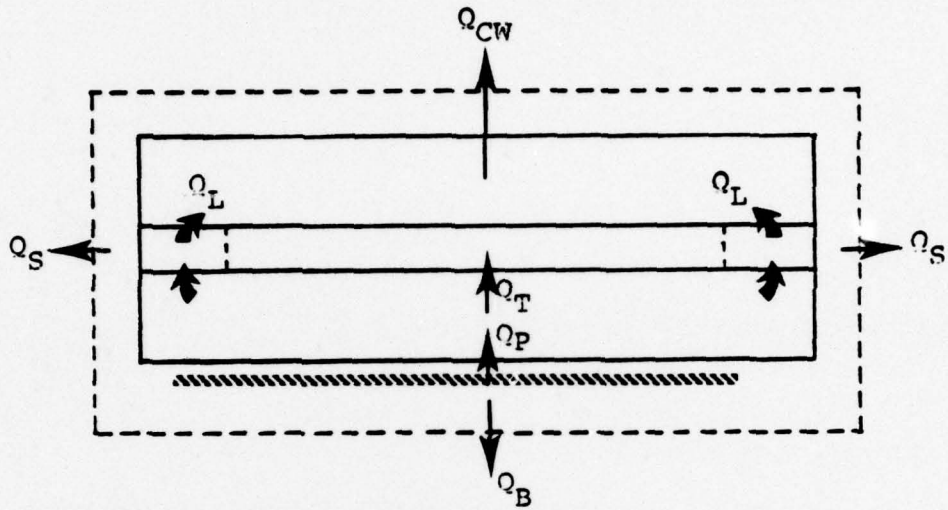

FIGURE 12. Energy Balance in Test Chamber

SAMPLE CALCULATIONS

A. DATA

T_{INS}	1	=	93.9 °F
T_{CW}	2	=	73.1 °F
T_C	3	=	87.9 °F
T_C	4	=	88.1 °F
T_C	5	=	88.1 °F
T_C	6	=	88.3 °F
T_C	7	=	87.9 °F
T_{CW}	8	=	72.8 °F
T_G	9	=	80.6 °F
T_G	10	=	81.1 °F
T_G	11	=	80.9 °F
T_G	12	=	81.3 °F
T_G	13	=	81.3 °F
T_{INS}	14	=	94.1 °F
T_{INS}	15	=	94.3 °F
T_{INS}	16	=	93.8 °F
T_{INS}	17	=	94.4 °F
T_{INS}	18	=	93.7 °F
T_{CW}	19	=	72.8 °F
T_{CW}	20	=	73.1 °F

E_H	=	13.98 V
E_R	=	2.31 V
E_{GH}	=	4.10 V

$$\begin{aligned}
R &= 2.031 \Omega \\
F_{CW} &= 120.2 \text{ lbm/Hr} \\
T_{\infty} &= 75 \text{ }^{\circ}\text{F} \\
k_P &= 0.120 \text{ Btu/Hr/ft/}^{\circ}\text{F} \\
A_P &= 0.0903 \text{ ft}^2 \\
L &= 0.01167 \text{ ft} \\
k_{INS} &= 0.096 \text{ Btu/Hr/ft/}^{\circ}\text{F} \\
A_B &= 0.25 \text{ ft}^2 \\
L_B &= 0.08333 \text{ ft} \\
L_S &= 0.02983 \text{ ft} \\
C_{CW} &= 0.998 \text{ Btu/Lbm/}^{\circ}\text{F} \\
\beta &= 2.683 \times 10^{-4} \text{ 1/}^{\circ}\text{F} \\
\nu &= 5.6625 \times 10^{-5} \text{ ft}^2/\text{sec} \\
k_{LIQ} &= 0.232 \text{ Btu/Hr/ft/}^{\circ}\text{F} \\
\rho_{LIQ} &= 71.02 \text{ Lbm/ft}^3 \\
C_{LIQ} &= 0.7636 \text{ Btu/Lbm/}^{\circ}\text{F} \\
A_{LIQ} &= 0.25 \text{ ft}^2
\end{aligned}$$

B. TEMPERATURE CALCULATIONS

1. Average Copper Plate Temperature (T_C)

$$\begin{aligned}
T_C &= \frac{T_C 3 + T_C 4 + T_C 5 + T_C 6 + T_C 7}{5} \\
&= \frac{87.9 + 89.1 + 88.1 + 88.3 + 87.9}{5} \\
&= 88.1 \pm 0.2 \text{ }^{\circ}\text{F}
\end{aligned}$$

2. Average Glass Plate Temperature (T_G)

$$\begin{aligned} T_G &= \frac{T_G \ 9 + T_G \ 10 + T_G \ 11 + T_G \ 12 + T_G \ 13}{5} \\ &= \frac{80.6 + 81.1 + 80.9 + 81.3 + 81.3}{5} \\ &= 81.0 \pm 0.4 \text{ } ^\circ\text{F} \end{aligned}$$

3. Temperature Difference Between the Two Plates (ΔT)

$$\Delta T = T_C - T_G = 88.1 - 81.0 = 7.1 \pm 0.6 \text{ } ^\circ\text{F}$$

4. Film Temperature (T_F)

$$T_F = \frac{T_C + T_G}{2} = \frac{88.1 + 81.0}{2} = 84.5 \text{ } ^\circ\text{F}$$

5. Temperature Rise in the Cooling Water (ΔT_{CW})

$$\Delta T_{CW} = T_{CW \ 2} - T_{CW \ 8} = 73.1 - 72.8 = 0.3 \text{ } ^\circ\text{F}$$

6. Temperature Difference in the Insulation (ΔT_{INS})

$$\begin{aligned} \Delta T_{INS} &= \frac{T_{INS \ 1} + T_{INS \ 17} + T_{INS \ 18}}{3} - \frac{T_{INS \ 14} + T_{INS \ 15} + T_{INS \ 16}}{3} \\ &= \frac{93.9 + 94.4 + 93.7}{3} - \frac{94.1 + 94.3 + 93.8}{3} \\ &= 94.0 - 94.1 = 0.1 \pm 0.3 \text{ } ^\circ\text{F} \end{aligned}$$

7. The Difference Between the Room Temperature and The Film Temperature (ΔT_{∞})

$$\Delta T_{\infty} = T_F - T_{\infty} = 84.5 - 75.0 = 9.5 \text{ }^{\circ}\text{F}$$

C. POWER CALCULATIONS

1. Supplied Power (Q_P)

$$Q_P = \frac{E_R E_H}{R} = \frac{(2.31)(13.98)}{2.031}$$
$$= 15.90 \text{ W} = 54.3 \text{ Btu/hr}$$

2. Heat Leakage Through the Plexiglass Shim (Q_L)

$$Q_L = \frac{k_P A_P \Delta T}{L} = \frac{(.120)(0.0903)(7.1)}{0.01167}$$
$$= 6.6 \text{ Btu/hr}$$

3. Heat Loss Through the Insulation (Q_{INS})

$$Q_{INS} = Q_B + Q_S$$
$$= \frac{k_{INS} A_B \Delta T_{INS}}{L_B} + \frac{k_{INS} A_S \Delta T_{\infty}}{L_S}$$
$$= \frac{(0.096)(0.25)(0.1)}{0.0833} + \frac{(0.096)(0.1244)(9.5)}{0.02083}$$
$$= 0.03 + 5.5 = 5.53 \text{ Btu/hr.}$$

4. Heat Transferred to the Test Chamber (Q_T)

$$\begin{aligned} Q_T &= Q_P - (Q_{INS} + Q_L) \\ &= 54.3 - (5.53 + 6.6) = 42.2 \text{ Btu/hr} \end{aligned}$$

5. Heat Transferred to the Cooling Chamber (Q_{CW})

$$\begin{aligned} Q_{CW} &= F_{CW} C_{CW} \Delta T_{CW} \\ &= (120.2)(0.998)(0.2) = 42.0 \text{ Btu/hr} \end{aligned}$$

D. DIMENSIONLESS NUMBERS

1. Rayleigh Number (Ra)

$$\begin{aligned} Ra &= \frac{g \beta \Delta T L^3}{\alpha \nu} \\ &= \frac{(32.174)(2.683 \times 10^{-4})(7.02)(1.167 \times 10^{-2})^3}{(71.02)(0.7636)(3600) \cdot (5.6625 \times 10^{-5})} \\ &= 1430.2 \end{aligned}$$

2. Nusselt Number (Nu)

$$\begin{aligned} Nu &= \frac{Q_T L}{k_{LIQ} \Delta T A_{LIQ}} \\ &= \frac{(42.2494)(1.167 \times 10^{-2})}{(0.232)(7.02)(0.25)} = 1.2106 \end{aligned}$$

3. Prandtl Number (Pr)

$$\text{Pr} = \frac{\nu}{\alpha}$$

$$= \frac{(5.6625 \times 10^{-5}) (3600)}{\frac{0.232}{(71.02) (0.7636)}}$$

$$= 47.6507$$

APPENDIX C

UNCERTAINTY ANALYSIS

The uncertainties for the variables and the dimensionless numbers in this experimental study were calculated by the method proposed by Kline and McClintock [Ref. 18].

The second-power equation of Kline and McClintock was used for the calculation of uncertainties in the values obtained experimentally.

The basis for uncertainties in the temperature readings was the calibration of the thermocouples. For all measured quantities the accuracy of the measuring instrument was the basis for uncertainties. Uncertainties for the properties of the test liquids were given in the references where these properties were obtained.

As an example, the calculation of the uncertainty in the Rayleigh number for the same case taken for sample calculations is given below. The Rayleigh number was defined as:

$$Ra = \frac{g \beta \Delta T L^3}{\nu \alpha}$$

and the uncertainty was calculated by the second-power equation of Kline and McClintock as:

$$\begin{aligned} \frac{dRa}{Ra} &= \left(\frac{d\beta}{\beta}\right)^2 + \left(\frac{d\Delta T}{\Delta T}\right)^2 + 3\left(\frac{dL}{L}\right)^2 + \left(\frac{dv}{v}\right)^2 + \left(\frac{d\alpha}{\alpha}\right)^2 \\ &= (0.0121)^2 + (0.085)^2 + 3(0.060)^2 + (0.001)^2 + (0.0102)^2 \\ &= 13.5\% \end{aligned}$$

Using the same formula uncertainty in the Nusselt number and the Prandtl number was found to be 16.4% and 1.143% respectively.

The values of the uncertainties for other variables are listed below. Because of the low temperature difference, the uncertainties are higher than average for this case.

<u>Quantity</u>	<u>Uncertainty</u>
$d\rho_{LIQ}/\rho_{LIQ}$	0.0010
dv_{LIQ}/v_{LIQ}	0.0100
dC_{LIQ}/C_{LIQ}	0.010
dk_{LIQ}/k_{LIQ}	0.0010
dk_p/k_p	0.030
dk_{INS}/k_{INS}	0.020

<u>Quantity</u>	<u>Uncertainty</u>
dL/L	0.060
dL_{INS}/L_{INS}	0.050
dE_H/E_H	0.0010
dE_R/E_R	0.0050
dR/R	0.0005
$d\Delta T/\Delta T$	0.0850
$d\beta/\beta$	0.0121
dQ_P/Q_P	0.0051
dQ_L/Q_L	0.1101
dQ_{INS}/Q_{INS}	0.0587
dQ_T/Q_T	0.1255
$d\alpha/\alpha$	0.0102

<u>Quantity</u>	<u>Uncertainty</u>
dA_{LIQ}/A_{LIQ}	0.020
dA_B/A_B	0.020
dA_S/A_S	0.020
dA_P/A_P	0.020
dL_B/L_B	0.050

LIST OF REFERENCES

1. Lord Rayleigh, Phil. Mag., Series 6, Vol. 32, 529-546 (1916).
2. Benard, Rev. Gen. Sci., 11, 1261-1271, 1309-1328 (1900).
3. Jeffreys, H., Phil. Mag., Vol 2, 883-844 (1926).
4. Jeffreys, H., Proc. Roy. Soc. (London). A 118, 195 (1928).
5. Low, A. R., Proc. Roy. Soc. (London), A 125, (1929).
6. Sutton, O. G., Proc. Roy. Soc. (London), A 225, 185 (1954).
7. Malkus, W. V. R., Proc. Roy. Soc. (London), A 225, 185 (1954).
8. Cotton, I., Physics of Fluids, Vol. 9, No. 12, 2521-2522 (1966).
9. Schmidt, R. J., and S. W. Milverton, Proc. Roy. Soc. (London), A 152, 586 (1935).
10. Chandra, K., Proc. Roy. Soc. (London), A 164, 231 (1938).
11. DeFraaf, J. G. A., and E. F. M. Van Der Held, Appl. Sci. Res., A3, 393 (1952).
12. Schmidt, E. and P. L. Silveston, Chem. Eng. Progr. Symposium Ser., No. 29, 55, 163 (1959).
13. Mull, W., and H. Reiher, Beih. Z. Gesundheitstech. Ing., Series 1, 28 (1930).
14. Mobil Technical Service Division, Mobil Technical Bulletin: Heating with Mobiltherm, II-14 (1971).
15. Geiringer, P. L., Handbook of Heat Transfer Media, 142-149, Reinhold Publishing Corporation (1962).
16. Tovloulkian, Y. S., and others, Thermophysical Properties of Matter, V. 3 and V. 6, IFI/Plenum (1970).
17. Miner, C. S., and Dalton, N. N., Glycerol, Reinhold Publishing Corporation (1953).
18. Kline, S. J., and McClintock, Mechanical Engineering, V. 75, 3-8 (1953).

INITIAL DISTRIBUTION LIST

	No. Copies
1. Defense Documentation Center Cameron Station Alexandria, Virginia 22314	2
2. Library, Code 0142 Naval Postgraduate School Monterey, California 93940	2
3. Associate Professor M. Kelleher, Code 69Kk Department of Mechanical Engineering Naval Postgraduate School Monterey, California 93940	2
4. Dz. Yzb. Mahmut Yurteri Kiziltoprak Sari Lale Sokak 2/3 Kadikoy - Istanbul TURKEY	3
5. Department of Mechanical Engineering Naval Postgraduate School Monterey, California 93940	1