

AD-A048 365

LTV AEROSPACE CORP DALLAS TEX VOUGHT SYSTEMS DIV F/G 15/7
SEATIDE ANALYSIS PROCESS. VOLUME IIID. CRUISE MISSILE - CONCEPT--ETC(U)
JAN 74 G S MCCORKLE DAAB09-72-C-0062
VSD-00.1636-VOL-3D NL

UNCLASSIFIED

1 of 2

ADAO48366

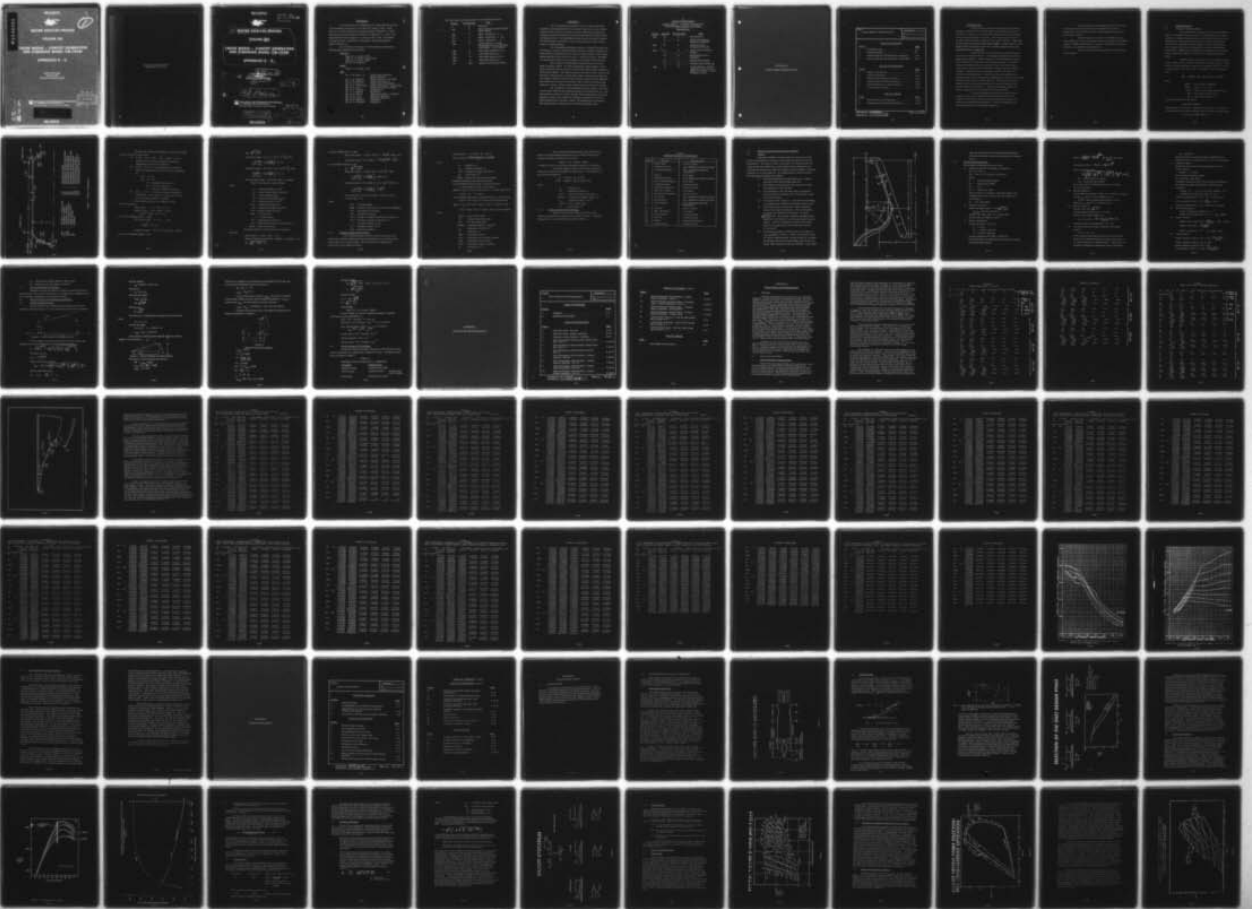

UNCLASSIFIED

12



AD A 048365

SEATIDE ANALYSIS PROCESS

VOLUME IIID

CRUISE MISSILE - CONCEPT GENERATION AND SCREENING MODEL (CM-CGSM)

APPENDICES D - G

Ac 48340

REPORT NO. 00.1636
JANUARY 1974
(CONTRACT DAAB09-72-C-0062)

DDC
RECEIVED
JAN 18 1978
D

 **VOUGHT SYSTEMS DIVISION**
LTV AEROSPACE CORPORATION
P.O. BOX 5907 • DALLAS, TEXAS 75222

AD NO. _____
DDC FILE COPY

DISTRIBUTION STATEMENT A
Approved for public release;
Distribution Unlimited

UNCLASSIFIED

Approved for public release;
distribution unlimited.

UNCLASSIFIED

VMSC/SEATIDE/ 1110
ITEM 1 COPY NO. 12
FILE _____



6 **SEATIDE ANALYSIS PROCESS**

VOLUME III D.

**CRUISE MISSILE - CONCEPT GENERATION
AND SCREENING MODEL (CM-CGSM)**

APPENDICES D - G,

ACCESSION BY	
RTIC	Write Section <input checked="" type="checkbox"/>
DDG	Bull Section <input type="checkbox"/>
UNANNOUNCED	<input type="checkbox"/>
JUSTIFICATION	
BY	
DISTRIBUTION/AVAILABILITY CODES	
SPEC. AVAIL. and/or SPECIAL	
A	

14 VSD-
REPORT 00 1636-VOL-3D
11 JAN 1974
(CONTRACT DAAB09-72-C-0062)

15

12 189p.

10 G. S. / McCorkle

VOUGHT SYSTEMS DIVISION
LTV AEROSPACE CORPORATION
P.O. BOX 5907 • DALLAS, TEXAS 75222

DISTRIBUTION STATEMENT A
Approved for public release;
Distribution Unlimited

DDC
RECEIVED
JAN 18 1978
RECEIVED

UNCLASSIFIED

408-116

D
Jmc

FOREWORD

(U) This report was prepared by the Vought Systems Division, LTV Aerospace Corporation, P. O. Box 6267, Dallas, Texas 75222 under U. S. Army Electronics Command Contract DAAB09-72-C-0062. The work was initiated under the direction of Captain R. A. Dowd, USN and completed under Captain W. A. Greene, USN, Chief, Long Range Forecast Division, Directorate of Estimates, Defense Intelligence Agency (DIA-DE-1).

(U) Persons contributing to the development and testing of the procedure reported herein include:

DIA-DE-1

Capt. W. A. Greene, USN
Capt. R. A. Dowd, USN (Retired)
Capt. R. F. Weiss, USAF
Mr. R. E. McQuiston

ARPA

Cmdr. T. W. Hogan, USN

VSD

Mr. J. S. Smith, Jr.	Chief Project Engineer, Special Projects
Dr. L. D. Gregory	Project Engineer, SEATIDE
Mr. J. R. Matthews	Models and Analysis
Mr. F. E. Dye, Jr.	Technologies (CM-CGSM)
Mr. R. K. McDonough	Models and Analysis (CM-CGSM)
Mr. R. E. Dyer	Models and Analysis (NEM)
Mr. G. G. Johnson	Aerodynamics
Dr. J. A. Bottorff	Propulsion
Mr. A. C. Morris	Electronics (Radar, Guidance)
Mr. H. R. Crow	Operations Research
Mr. G. H. Harris	Operations Research
Mr. G. S. McCorkle	Propulsion
Mr. L. D. Cardwell	Propulsion

(U) This report has been prepared in the following volumes:

<u>Volume</u>	<u>Classification</u>	<u>Title</u>
I	S	Summary
AD48340 IIA	U	Naval Engagement Model (NEM) - Users Manual
✓ IIB	U	NEM - Appendices A - I
IIC	S	NEM - Appendices J - M
✓ IID	U	NEM - Appendices N
✓ IIA	U	Cruise Missile - Concept Generation and Screening Model (CM-CGSM) - Users Manual
✓ IIB	U	CM-CGSM Appendices A-B
IIC	S	CM-CGSM Appendix C
IID	U	CM-CGSM Appendices D-G
IIE	U	CM-CGSM Appendix H
IV	S U	Relative Worth Model (RWM)

ABSTRACT

(U) The SEATIDE Analysis Process is a semi-automated procedure for the generation of time-phased, high value cruise missile weapon systems concepts, together with the supporting technology and intelligence indicators which would reflect that these technological goals are being achieved. The SEATIDE process can also be used to evaluate the effectiveness of fixed force levels, existing forces in SAL environments, or Naval defenses.

(U) The Defense Intelligence Agency, through its Directorate of Estimates, and The Advanced Research Projects Agency (ARPA) have sponsored the development of this computer based analysis at the weapon system and Naval force structure level. A previous process, RIPTIDE, was developed for DIA for use in analysis of strategic missile systems.

(U) Generic to the SEATIDE Analysis Process are three major computer models: The Naval Engagement Model (NEM), Cruise Missile Concept Generation and Screening Model (CM-CGSM) and Relative Worth Model (RWM). The NEM evaluates force effectiveness, tactics, and task force configurations; the CM-CGSM enables definition and selection of candidate, advanced cruise missile system concepts; and the RWM permits assessment of worth in accordance with a variety of objective and subjective criteria. Each of these models has been checked out by DIA.

(U) In addition to exercising the computer models, there are several other analytical and engineering tasks to be performed, e.g., the identification of areas of current interest and the associated criteria and potential concepts, the creation of a foreign technology data bank in a format needed by the computer models, the engineering of concepts to the required detail, and the use of a verification analysis loop.

↓
TABLE OF CONTENTS -

CRUISE MISSILE - CONCEPT GENERATION
AND SCREENING MODEL (CM-CGSM)

APPENDICES -

<u>Volume</u>	<u>Appendix</u>	<u>Classification</u>	<u>Title</u>
IIIB	A	U	Aerodynamics
	B	U	Vehicle Performance Submodel (VEHPER)
IIIC	C	S	Liquid and Solid Propulsion Submodel
IIID	D	U	Cruise Missile Booster Sizing
	E	U	Inlet Sizing and Per- formance
	F	U	Ramjet Sizing Model
	G	U	Turbojet Sizing Model
IIIE	H	U	Cruise Missile - Concept Generation and Screening Model (CM-CGSM) - Source Program Listing

APPENDIX D

CRUISE MISSILE BOOSTER SIZING

TITLE CRUISE MISSILE BOOSTER SIZING	Appendix D
	NO. _____
	DATE _____

TABLE OF CONTENTS

<u>Section</u>	<u>Page</u>
1. INTRODUCTION	D-2
2. BOOSTER SIZING	D-4
3. NOZZLE SIZING FOR INTEGRAL RAMJETS	D-14
4. NOZZLE SIZING FOR EXTERNAL BOOSTERS ...	D-21

LIST OF ILLUSTRATIONS

<u>Figure</u>	<u>Page</u>
1 Booster Configuration	D-7
2 Nozzle Configuration	D-16
3 Integral Nozzle MOI and CG Model	D-20
4 Nozzle Model for External Boosters	D-21
5 Nozzle Modeling for Canted Systems	D-22
6 Nozzle Reduction Model	D-23

LIST OF TABLES

<u>Table</u>	<u>Page</u>
I Booster MOI and CG Modeling	D-13
II External Nozzle MOI and CG Modeling	D-24

PREPARED BY *L. D. Gregory*
APPROVED BY L. D. Gregory *(L.D.G.)*

1. INTRODUCTION

Cruise missile boosters are required for two primary purposes. The first use of a boost phase is to accelerate a ramjet to its take-over velocity or to accelerate a turbojet system from a surface launch to an efficient take-over point. The second use of a booster is to reduce overall lengths of liquid and solid rocket systems. When used in this manner the booster sizing module BOOST assumes that one or two strap-on solid rocket motors are used, and those motors burn to fuel depletion during an engagement.

Ramjet systems may be boosted by an integral booster as well as by external boosters. The integral configuration contains a single tandem booster. After completion of the boost phase the rocket motor combustor is also used for the ramjet combustor. As ramjet throat area requirements are much larger than rocket throat area requirements, dual use of the combustion chamber requires different nozzles. Consequently the rocket nozzle is sized to fit within the confines of the ramjet nozzle. Retention of the rocket nozzle is by Marmon clamp which is assumed to be separated by explosive bolts during transition from rocket to ramjet operation. The size and structural requirements of the ramjet combustor are usually exceeded by the booster chamber requirements. Therefore the integral ramjet combustor configuration is a by-product of the booster design.

For ramjet designs requiring non-integral boosters (external), the velocity requirements are assumed to be met by strap on rocket motors which are mounted alongside the ramjet combustor and jettisoned during transition. For this configuration the ramjet combustor must be designed separately.

Booster motors for liquid/solid rockets and turbojets are assumed to be identical to the non-integral ramjet; that is, rocket motors mounted along side the turbojet engine and jettisoned after booster burnout.

Ramjet boosters are sized by the BOOST module, while liquid/solid rocket and turbojet boosters are sized by the EXBOO module. EXBOO methodology is a subset of the BOOST methodology, therefore, only BOOST is discussed here.

Specific input formats are discussed in Volume IIIA Users Manual.

2.0 BOOSTER SIZING

2.1 GENERAL BOOSTER SIZING

The performance calculations in subroutine BOOST are based on a straightforward application of standard solid rocket design equations. Hardware weights, however, derive from both theoretical and empirical relationships and hardware constants are made input variables for computing component weights. These constants have built in values which may be overridden by the user if desired (see Volume IIIA). BOOST has the capability of providing a detailed breakdown of component weights to aid the user in evaluating the booster design.

BOOST requires initial values of the propellant weight, thrust, and burn time in order to initiate the convergence logic. These values, calculated internally, affect the convergence efficiency but not the final design. The initial value for propellant weight is computed from:

$$MP = (WRAT * ML - ML)/(1.2 - 0.2 * WRAT)$$

where

$$WRAT = \exp [\Delta V / 32.174 / ISP(1)]$$

$$ISP(1) = cstar * 1.5 / 32.174$$

cstar = input value of characteristic velocity

ΔV = input ideal velocity, ft/sec

ML = input payload weight, lb

The initial estimate of burn time is

$$TB = MP * ISP / F(1)$$

Either thrust or the thrust to weight ratio may be input. If the thrust to weight ratio (F1) is input a starting value for thrust is obtained from

$$F(1) = (1.2 * MP + ML) * F1$$

2.1.1 Pressure Vessel Sizing

The pressure vessel material is selected by the user by inputting a material code. The material properties are obtained by calling subroutine MATLS with the desired material code and the case design temperature. MATLS returns the ultimate tensile strength, the yield tensile strength and the density. Subroutine MATLS is described in Appendix F of this volume.

$$\rho = f(\text{material code})$$

$$F_{\text{ult}}, F_{\text{yield}} = f(\text{material code, design temperature})$$

BOOST calculates the pressure vessel thicknesses based on a nominal chamber pressure, ultimate tensile strength and a compound factor of safety (F.S._u). The computed factor of safety, input to the routine as a single value, is based on a shape factor (nominal maximum pressure divided by nominal average pressure), a ballistic factor (+3 sigma variation in propellant burn rate and "C"-Star), a temperature factor (variation with temperature) and a structural safety factor. Similar calculations are repeated for thickness based on yield. Final thicknesses are then based on the maximum of the "yield" thickness, the "ultimate" thickness, and an input minimum allowable thickness based on handling and buckling considerations. Cylinder thicknesses are as follows:

$$TC_y = F.S._y * PC * D / (F_y^2),$$

$$TC_u = F.S._u * PC * D / (F_u^2),$$

and $TC = \text{minimum}(TC_y, TC_u, TC_{\text{min}})$

(U) Forward closure thicknesses are as follows:

$$TFH_y = F.S._y * PC * D * E_F / (F_y^4),$$

$$TFH_u = F.S._u * PC * D * E_F / (F_u^4),$$

and $TFH = \text{minimum}(TFH_y, TFH_u, TH_{\text{min}})$

(U) Aft closure thicknesses are as follows:

$$TAH_y = F.S._y * PC * D * E_A / (F_y * 4),$$

$$TAH_u = F.S._u * PC * D * E_A / (F_u * 4),$$

and $TAH = \text{minimum} (TAH_y, TAH_u, TH_{\min}).$

2.1.2 Chamber Sizing

Chamber weights include skirt weights, forward head weights, cylinder weights, and aft head weights. Forward and aft skirt weights (see Figure 1) are respectively computed from the following equations:

$$\begin{aligned} \text{FORSKT} = & N34 + N35 * TC * \pi * D * \rho \\ & + \left\{ \frac{\text{GMAX} * \text{ML}}{N37} * .0215 \left[\left(\frac{\text{LCYL} + D/N2}{D} \right) + 1 \right] \right\}^{1/2} \\ & * N36 * D^2 + \text{DLFS} * \pi * TC * \rho \end{aligned}$$

$$\begin{aligned} \text{AFTSKT} = & N38 + N39 * TC * \pi * D * \rho \\ & + N40 * D^2 * \left\{ \frac{\text{ML} + \text{MP}/2}{N37} * 0.215 \left[\left(\frac{\text{LCYL} + D/N23}{D} \right) + 1 \right] \right\}^{1/2} \end{aligned}$$

where

N34 = Miscellaneous forward skirt weight, lbs.

N35 = Forward skirt weight multiplier

N36 = Forward skirt weight multiplier

N37 = Modulus of elasticity, psi

N38 = Miscellaneous aft skirt weight, lbs.

N39 = Aft skirt weight multiplier

N40 = Aft skirt weight multiplier

ML = Payload weight, lbs.

GMAX = Maximum load factor

MP = Propellant weight, lbs.

DLFS = Skirt extension, in.

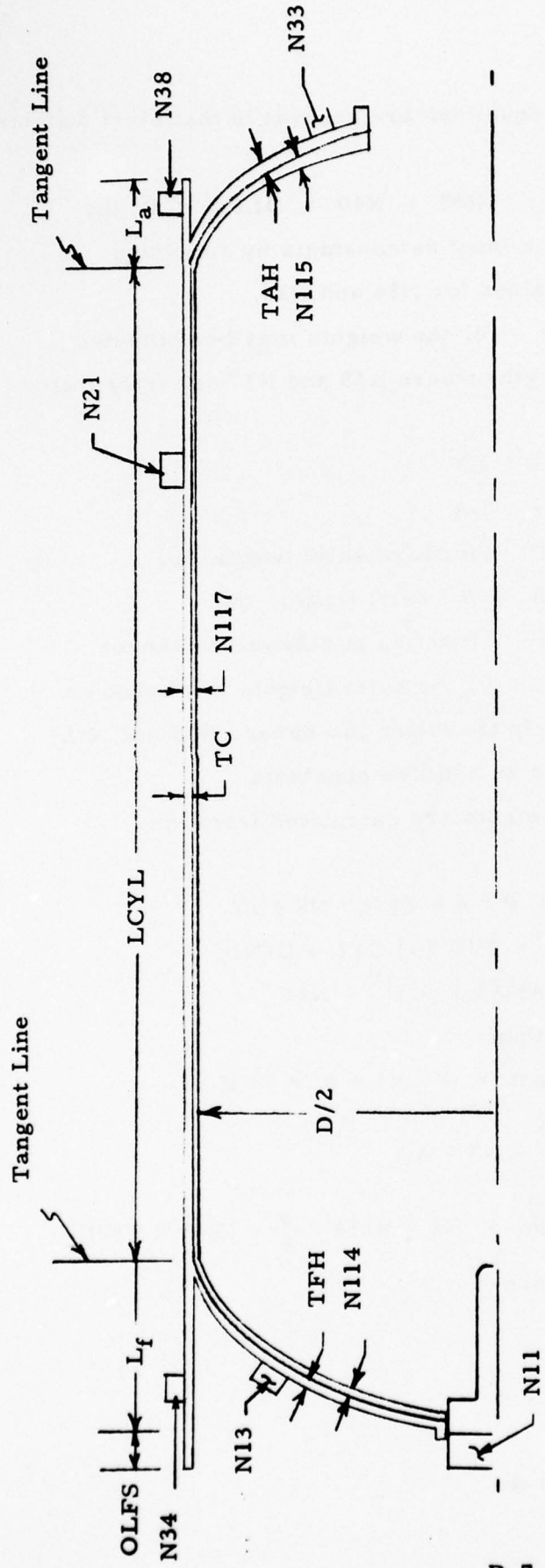

- TFH = Thickness, Forward Head
- TC = Thickness, Sidewall
- TAH = Thickness, Aft Head
- DLFS = Forward Skirt Extension
- L_f = Length Forward Skirt
- L_a = Length Aft Skirt
- D = Diameter
- N11 = Safe and Arm Weight
- N13 = Miscellaneous Forward Head Weight
- N21 = Miscellaneous Cylinder Weight
- N33 = Miscellaneous Aft Head Weight
- N34 = Miscellaneous Forward Skirt Weight
- N38 = Miscellaneous Aft Skirt Weight
- N114 = Forward Insulation Thickness
- N115 = Average Aft Insulation Thickness
- N117 = Sidewall Insulation Thickness

Figure 1. Booster Configuration

The above two equations are general in that skirt weights may be computed in three ways:

- (1) If $N35 = N36 = N39 = N40 = DLFS = 0$, the weights may be input as constants by supplying appropriate values for $N34$ and $N38$.
- (2) If $N36 = N40 = 0$, the weights may be computed from skirt lengths where $N35$ and $N37$ are interpreted as:

$$N35 = F * LF$$

$$N36 = F * LA$$

LF = forward skirt length, in.

LA = Aft skirt length, in.

F = fraction of sidewall thickness

- (3) If $N35 = N39 = 0$, the skirt weights are based on correlations. In the latter two cases, $N35$ and $N38$ may be utilized as additive constants.

Forward head weights are calculated from the following equations:

$$\text{Boss weight} = \rho * 4 * TFH * N9 * At$$

$$\text{Igniter weight} = N10 * (LCYL + D/N2) * (N120 * AFAT * At)^{1/2} + N11$$

If the forward ellipse ratio = 1, then

$$\text{Structural weight} = 4 * N1 * \rho * TFH$$

$$* \left(\frac{\pi * D^2}{2} - N3 * At \right)$$

$$\text{Insulation weight} = N4 * N114 * \frac{\pi}{2} * (D - 2 * TFH)^2$$

If the forward ellipse ratio $\neq 1$, then

$$\text{Say} = \sqrt{1 - 1/N2^2}$$

$$\text{Structural weight} = 4 * N1 * \rho * \text{TFH} * D^2 * \left\{ 0.7854 + \frac{0.3925}{N2^2 * \text{Say}} * \log\left(\frac{1 + \text{Say}}{1 - \text{Say}}\right) \right\} - N3 * \text{At}$$

$$\text{Insulation weight} = N4 * N114 * (D - 2 * \text{TFH})^2 * \left\{ 0.7854 + \frac{0.3925}{N2^2 * \text{Say}} * \log\left(\frac{1 + \text{Say}}{1 - \text{Say}}\right) \right\} - N3 * \text{At}$$

Forward head weight = structural weight + insulation weight + boss weight + igniter weight

where:

- ρ = structural density, lb/in³
- N1 = forward head weight multiplier
- N2 = forward ellipse ratio
- N3 = igniter port area/throat area
- N4 = insulation density, lb/in³
- N114 = insulation thickness, in.
- N9 = igniter boss weight multiplier
- N10 = igniter weight multiplier
- N120 = 0, end burner
= 1, center burner
- N11 = safe and arm weight, lb.
- N13 = Miscellaneous forward head weight, lb.
- AFAT = port to throat ratio

Aft head weights are calculated from the following

equations:

$$\text{Boss weight} = 4 * N30 * \text{TAH} * \rho * D$$

$$\text{Maximum insulation thickness} = \text{TAHIM} = 2 * \text{TAHIA} - N117$$

$$\text{DN} = \sqrt{\frac{\pi}{4} * \text{EPSC} * \text{At}}$$

If the aft ellipse ratio = 1, then

$$\text{Structural weight} = 4 * N22 * \text{TAH} * \rho * \left(\frac{\pi * D^2}{2} - \text{EPSC} * \text{At} \right)$$

$$\text{Insulation weight} = N4 * \text{TAHIA} * \pi * \left[\frac{(D-2 * \text{TAH})^2}{2} - \frac{DN^2}{4} \right]$$

If the aft ellipse ratio \neq 1, then

$$\text{Say} = \sqrt{1 - 1/N23^2}$$

$$\text{Structural weight} = 4 * N22 * \text{TAH} * \rho * \left\{ D^2 * 0.7854 + \frac{0.3925}{N23^2 * \text{Say}} * \log\left(\frac{1+\text{Say}}{1-\text{Say}}\right) \right\} - \text{EPSC} * \text{At}$$

$$\text{Insulation weight} = N4 * \text{TAHIA} * \left\{ (D-2 * \text{TAH})^2 * 0.7854 + \frac{0.3925}{N23^2 * \text{Say}} * \log\left(\frac{1+\text{Say}}{1-\text{Say}}\right) \right\} - \frac{\pi * DN^2}{4}$$

$$\text{Aft head weight} = \text{structural weight} + \text{insulation weight} + \text{boss weight} + N33$$

where

N23 = aft ellipse ratio

EPSC = entrance area ratio (from subroutine RAMNOZ)

N33 = miscellaneous aft weight

N22 = aft weight multiplier

N115 = TAHIA = average aft insulation thickness, in.

N117 = Cylindrical insulation thickness, in.

ρ = structural density, lb/in³

N4 = insulation density, lb/in³

N30 = Aft boss multiplier

2.1.3 Propellant Weights and Volumes

The routine calculates a port to throat ratio based on the input cross-sectional loading and selects the greater of the calculated value and the input port to throat value. The cross sectional loading port to throat value is calculated as follows:

$$\text{Cross section} = \pi * (D/2 - TC - N117)^2$$

$$\text{Port to throat} = \frac{(\text{Cross section}) * (1 - \text{ETAX})}{A_t}$$

where

D = diameter, in.

TC = chamber thickness, in.

N117 = sidewall insulation thickness, in.

A_t = throat area, in²

ETAX = maximum cross sectional loading

Propellant weights are calculated as follows:

Forward head propellant weight = propellant density

x [semi-ellipse volume - Port volume]

$$\text{MPFH} = \rho_p * [2.9 * (D/2 - \text{TFH} - \text{N114})^2 * (.5 * D / \text{N2} - \text{TFH} - \text{N114}) - \text{AFAT} * A_t * .5 * D / \text{N2}]$$

Aft head propellant weight = propellant density x [semi-ellipse volume - Port volume] x [Aft head loading fraction]

$$\text{MPAH} = \rho_p * [2.09 * (D/2 - \text{TAH} - \text{N115})^2 * (.5 * D / \text{N23} - \text{TAH} - \text{N115}) - \text{AFAT} * A_t * (.5 * D / \text{N23} - \text{TAH} - \text{N115})] * \text{FMPAH}$$

where

AFAT = port to throat ratio

NL = forward head ellipse ratio

N23 = Aft head ellipse ratio

FMPAH = propellant loading in aft head

ρ_p = Propellant density lb/in³

D = Diameter, in.

TFH = thickness of the for

N114 = thickness of the forward insulator

TAH = thickness of the aft head

N115 = thickness of the aft insulator

A_t = throat area, in²

The cylindrical propellant weight is the difference between the total propellant weight and the sum of the forward and aft propellant weights according to the formula

$$MPCYL = MP - MPFH - MPAH$$

A negative value for the cylindrical propellant weight is not allowed.

Cylindrical length is based on the volume required to contain the cylindrical propellant calculated above. The equations for the cylindrical length are

$$A = \pi * (D/2 - TC - N117)^2$$
$$LCYL = MPCYL / \rho_p * (A - AFAT * At)$$

where

- D = diameter, in.
- TC = sidewall thickness, in.
- N117 = sidewall insulation thickness, in.
- MPCYL = cylindrical propellant weight, lbs.
- ρ_p = propellant density, lb/in³
- AFAT = port to thrust ratio
- At = throat area, in²

2.1.4 Booster Inertia and CG Modeling

Moments of inertia and centers of gravity of the booster subsystems are computed and compiled for output. Modeling assumptions for each subsystem are shown in Table I.

TABLE I
BOOSTER MOI AND CG MODELING

Item	Segment	Segment Model
1	Igniter Boss	Hollow Cylinder
2	Forward Closure	Semi- Elliptical or Spherical Shell
3	Forward Propellant	Semi- Ellipsoidal Solid with Perforation
4	Igniter	Point Mass
5	Forward Insulation	Semi- Elliptical or Spherical Shell
6	Mts. Forward Weights	Point Mass
7	Cylindrical Case	Cylindrical Shell
8	Cylindrical Insulation	Cylindrical Shell
9	Mts. Cyl. Weights	Point Mass
10	Cylindrical Propellant	Hollow Cylinder
11	Aft Closure	Semi- Elliptical or Spherical Shell
12	Aft Insulation	Semi- Elliptical or Spherical Shell
13	Aft Propellant	Semi- Ellipsoidal Solid with Perforation
14	Aft Boss	Hollow Cylinder
15	Mts. Aft Weights	Point Mass
16	Forward Skirt	Cylindrical Shell
17	Aft Skirt	Cylindrical Shell
18	Nozzle	Calculated Elsewhere
19	Nozzle Fairing	Cylindrical Shell

3.0 NOZZLE SIZING FOR INTEGRAL RAMJETS

3.1 General

Subroutine RAMNOZ calculates both the ramjet and booster nozzle configurations for integral rocket ramjets and the booster nozzle performance. The booster nozzle is assumed to be contained within the ramjet nozzle and retained by a clamp installed at the extreme aft end. Performance equations are based on standard rocket technology. Hardware equations are in part empirical. The configuration is shown in Figure 2. The following assumptions are obtained:

- (1) The radius forming the ramjet nozzle (RC) is equal to one-third of the ramjet throat radius (R5).
- (2) The thickness of the ramjet nozzle structure is equal to the thickness of the aft dome.
- (3) The dimensions of the retaining clamp are generally fixed including its thickness of 0.3 inches which is part of the nozzle length.
- (4) The ramjet nozzle contains a .2 inch flat for facilitating a seal between the ramjet nozzle and the booster nozzle.
- (5) The booster nozzle is made of two main components joined at the ramjet nozzle plane. The aft component, an ablator with density 0.0637 lbs/in^3 , is $0.2045 * \sqrt{T_{\text{BURN}}}$ thick. The forward component, graphite with a density of 0.0625 lbs/in^3 , is 50 percent thicker than the ablator. The two components are joined with a thrust band of 0.15 square inch cross section and a density of $.296 \text{ lb/in}^3$.
- (6) The entrance section is formed by an arc of radius RC (see assumption (1) above). The arc will extend through 45° unless a different value is input by the user or unless the forward edge radius exceeds eight tenths of the combustor radius measured from the centerline. In the latter

case, the routine will set the intersection between the aft dome and entrance section at eight tenths of combustor radius.

3.2

Nozzle Sizing Methodology

The following computational steps are used:

- (1) Ramjet nozzle exit cone length is computed as

$$XA = RC * \sin \emptyset$$

$$XB = [R6 - RC*(1 - \cos \emptyset) - RS] / \tan \emptyset$$

where:

$$\emptyset = \text{nozzle half angle (input)}$$

$$R5 = \text{ramjet throat radius}$$

$$RC = R5/3$$

$$R6 = \text{ramjet exit radius}$$

The two values, XA and XB, when added together and multiplied by the bell fraction, give the ramjet exit cone length as

$$X1 = (XA + XB) * P_{bell}$$

- (2) Booster exit area is

$$\text{Ablator thickness (TIEC)} = .2045 \sqrt{T_{BURN}}$$

$$T_{BURN} = \text{booster burn time}$$

$$\text{Booster exit radius (RE)} = R6 - \text{TIEC} / \cos \emptyset$$

$$\text{Booster exit area (EXITA)} = RE^2 * \pi$$

- (3) Thrust coefficient is

$$\text{Thrust area (AT)} = F / DC / CF$$

$$F = \text{thrust}$$

$$PC = \text{chamber pressure}$$

$$CF = \text{thrust coefficient}$$

$$\text{Booster expansion ratio (EPS)} = \text{EXITA} / \text{AT}$$

Exit Mach number is determined by an iterative solution of the following equation:

$$EXITA = \frac{1}{M} \left[\left(\frac{2}{\gamma+1} \right) \left(1 + \frac{\gamma-1}{2} M^2 \right) \right]^{\frac{\gamma+1}{2(\gamma-1)}}, \gamma = \text{specific heat ratio (input)}$$

$$\text{Exit pressure (PE)} = PC / \left(1 + \frac{\gamma-1}{2} M^2 \right)^{\frac{\gamma}{\gamma-1}}$$

Thrust coefficient (CF) =

$$C_{FN} \left[\sqrt{\frac{2\gamma^2}{\gamma-1} \left(\frac{2}{\gamma+1} \right)^{\frac{\gamma+1}{\gamma-1}} \left[1 - \left(\frac{PE}{PC} \right)^{\frac{\gamma-1}{\gamma}} \right]} + \frac{PE-PA}{PC} * EPS \right]$$

PA = ambient pressure (input)

CF_n = thrust efficiency (input)

As C_F was used to calculate AT above, the solution for C_F is iterative.

(4) Specific impulse is

$$\text{Vacuum thrust coefficient (CFVA)} = CF + ESP * PA \times CF_n / PC$$

$$\text{Vacuum } I_{sp} \text{ (AISV)} = CFVA * CSTAR / 32.174$$

CSTAR = input constant characteristic velocity

$$\text{Delivered } I_{sp} \text{ (AISP)} = CF * CSTAR / 32.174$$

(5) Booster nozzle is

$$\text{Throat radius (RT)} = \sqrt{AT / \pi}$$

$$\text{Graphite half thickness (RCI)} = .75 * TIEC$$

Booster nozzle gross length (XI) =

$$RCI + RCI * \sin \emptyset + \frac{RE - RCI * (1 - \cos \emptyset) - RT}{\tan \emptyset}$$

$$\text{Booster throat to exit length (XN)} = XI - RCI$$

(6) Location of the booster throat relative to the ramjet throat is

$$X2 = XI - RCI - X2$$

If X2 is negative the booster pressure is insufficient to produce an acceptable design (the booster nozzle area is too large relative to the ramjet nozzle). Under these conditions the minimum acceptable pressure is calculated

$$PC = F/AT/CF$$

and the pressure is used for further calculations if the higher pressure is acceptable (if not the run is terminated).

- (7) Graphite weight is

Minimum graphite length (excluding length forward of booster throat)

$$X2MIN = .4 * D3/ER$$

D3 is combustor diameter (input)

ER is aft ellipse ratio (input)

If X2MIN is larger than X2, X2 is set equal to X2MIN and the weight of graphite displaced by the throat band is calculated.

$$WGADD = \frac{4}{\pi} * \rho_G (R_T + RCI) (X2 - X2MIN) * RCI$$

If X2MIN is less than X2, WGADD is zero.

$$\text{Radius of graphite (RBG)} = R_T + RCI + .6 * X2 * \text{TAN } \emptyset$$

$$\text{Area of graphite (AGB)} = 2 * RCI \frac{X2}{\text{COS } \emptyset} + RCI$$

$$\text{Weight of graphite (WG)} = 2\pi \rho_G * RBG * AGB + WGADD$$

- (8) Throat band weight is

$$\text{Radius of throat band (RBTB)} = R5 - .1$$

$$\text{Weight of throat band (WTB)} = 0.3 * \pi * \rho_{TB} * RBTB$$

- (9) Ablator weight is

$$\text{Ablator radius (RBA)} = R_E + \frac{TIEC}{2 * \text{COS } \emptyset} - \frac{X1}{2} * \text{TAN } \emptyset$$

$$\text{Ablator area (ABA)} = \frac{X1 * TIEC}{\text{COS } \emptyset}$$

$$\text{Ablator weight (WA)} = 2 * \pi * \rho_A * RBA * ABA$$

- (10) Clamp weight is

$$\text{Radius segment 1 (RBC1)} = R6 + 0.206 - \frac{0.35 * TIEC}{\text{COS } \emptyset}$$

$$\text{Radius segment 2 (RBC2)} = R6 + 0.6495$$

$$\text{Radius segment 3 (RBC3)} = R6 + 0.256$$

$$\text{Area segment 1 (ABC1)} = 0.1236 + \frac{0.21 * TIEC}{\text{COS } \emptyset}$$

$$\text{Weight of clamp (WC)} = 2\pi \rho_{WC} (RBC1 * ABC1 + 0.4313 * RBC2 + 0.11 * RBC3)$$

(11) Graphite length (XG) = X2 + RCI

(12) Insert weight (WTI) = WG + WA + WC + WTB

(13) Ramjet nozzle length

$$\text{Entrance height from throat (YZ)} = (1 - \cos \theta) * RC$$

where:

$$\theta \text{ is input (defaults to } 45^\circ \text{ if input as zero)}$$

$$\text{Maximum allowable height (YD)} = (R3 - R5) * .8$$

If YZ is greater than YD YZ is revalued to YD and θ is revalued to give YD.

$$\text{Ramjet nozzle entrance length (X3)} = RC * \sin \theta + .2$$

$$\text{Entrance height from centerline (YI)} = R5 + YZ$$

$$\text{Aft closure length (Z1)} = \sqrt{\frac{R3^2 - YI^2}{ER^2}}$$

$$\text{Ramjet nozzle length (XRN)} = Z1 + X3 + X1 + .3$$

(14) Ramjet nozzle weight is

$$\text{Exit cone segment radius (RBRN1)} = R6 + \frac{DELN}{2 \cos \theta} - \frac{XB * \tan \theta}{2}$$

DELN is thickness (input)

$$\text{Throat segment radius (RBRN2)} = R5 + DELN$$

$$\text{Entrance segment radius (RBRN3)} = R5 + RC *$$

$$\left(1 - \cos \left(.5236 + \frac{\theta}{2}\right)\right)$$

$$\text{Clamp retainer segment radius (RBRIV4)} = R6 + .2$$

$$\text{Exit cone segment area (ABRN 1)} = \frac{R6 - R5 (1 - \cos \theta - R5)}{\sin \theta} * DELN$$

$$\text{Throat segment area (ABRN2)} = 4 * RC * DELN * \sin \theta$$

$$\text{Entrance segment area (ABRN3)} = RC * \left(\frac{\pi}{3} - \theta\right) * DELN$$

$$\text{Ramjet nozzle weight (WRN)} =$$

$$2\pi \rho (RBRN1 * ABRN2 + RBRN2 * ABRN2 + RBRN3 * ABRN3 + .118 * RBRN4)$$

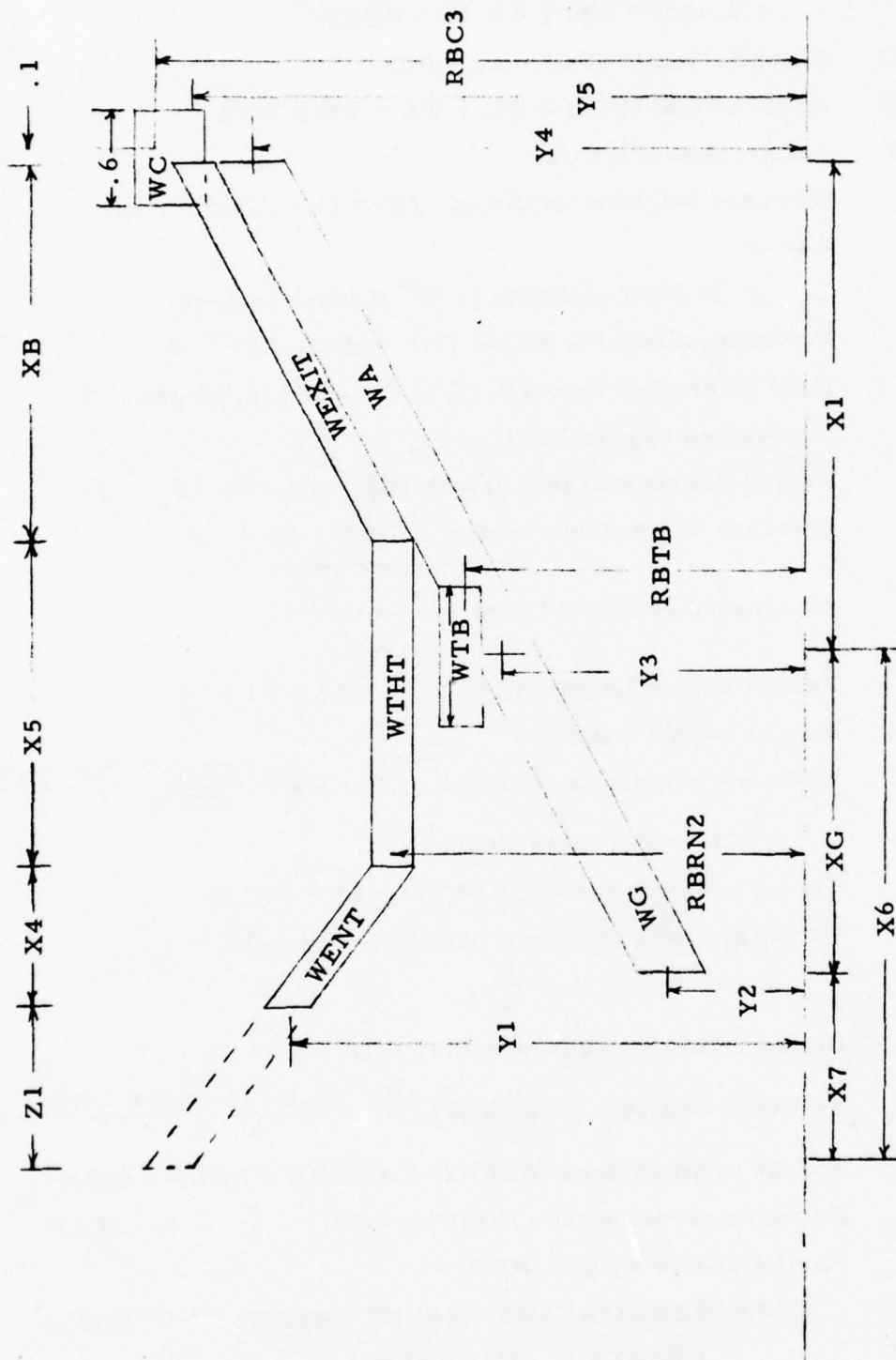

Figure 3 Integral Nozzle MOI and C. G. Model

$$(15) \quad \text{Total nozzle weight (WNTOT)} = \text{WRN} + \text{WTI}$$

$$(16) \quad \text{Entrance area ratio (EPSC)} = (\text{YI}/\text{RT})^2$$

3.3 Nozzle Inertia and CG Modeling

Moments of inertia and centers of gravity of the ramjet nozzle and the booster nozzle insert subsystems are computed and compiled for output. Modeling assumptions are illustrated in Figure 3.

4.0 NOZZLE SIZING FOR EXTERNAL BOOSTERS

4.1 Nozzle Sizing Methodology

Booster nozzles for externally boosted ramjets are not constrained by ramjet geometry, but are sized to the model shown in Figure 4.

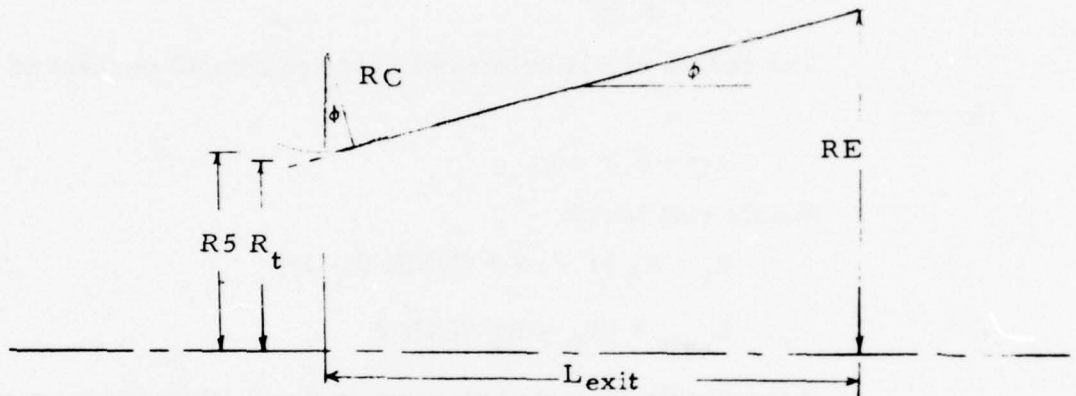

Figure 4. Nozzle Model for External Boosters

As the chamber pressure and pressure ratio are known, the expansion ratio can be determined from the following equation.

$$\epsilon = \left(\frac{\gamma+1}{2}\right)^{\frac{1}{\gamma-1}} * \left(\frac{P_c}{P_a}\right)^{\frac{1}{\gamma}} \sqrt{\frac{\gamma+1}{\gamma-1} \left[1 - \left(\frac{P_c}{P_a}\right)^{\frac{\gamma-1}{\gamma}}\right]}$$

Divergence factor,

$$F_\lambda = \frac{1 + \cos \phi}{2}$$

Thrust coefficient (vacuum)

$$C_{FV} = F_\lambda * \sqrt{\frac{2 * \gamma^2}{\gamma-1} * \left(\frac{2}{\gamma+1}\right)^{\frac{\gamma+1}{\gamma-1}} * \left[1 - \left(\frac{P_a}{P_c}\right)^{\frac{\gamma-1}{\gamma}}\right]} + \frac{P_a}{P_c} \epsilon$$

Thrust coefficient actual

$$C_F = (C_{FV} - \frac{P_A}{P_C} * \epsilon) * \eta_F$$

Specific impulse

$$I_{sp} = \text{CSTAR} * \text{CF} / 32.174$$

Throat area

$$A_t = F / P_c / C_F$$

Exit area and radius

$$A_{\text{exit}} = \epsilon * A_t$$

$$R_E = \sqrt{\frac{A_{\text{exit}}}{\pi}}$$

Throat area

$$R_5 = \sqrt{\frac{A_t}{\pi}}$$

The nozzle arc is arbitrarily set equal to 40 percent of the

throat

$$R_C = 0.4 * R_5$$

Nozzle exit length

$$R_t = R_5 [1 - .4 * (1/\text{SIN } \theta - 1)]$$

$$L_{\text{exit}} = (R_E - R_t) / \text{TAN } \theta$$

If the nozzle is canted at some angle β then the geometry changes to that of Figure 5.

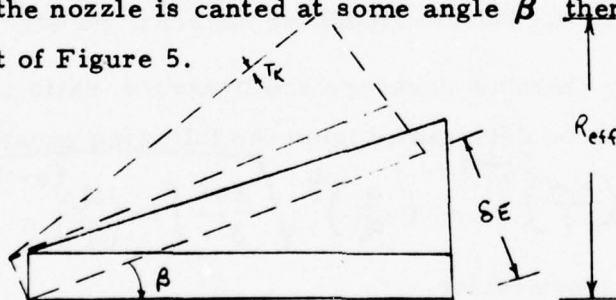

Figure 5. Nozzle Modeling for Canted Systems

The effective radius and area then become

$$\delta E = L_{\text{exit}} * \tan \beta$$

$$R_{\text{eff}} = (R_E + \delta E) * \cos \beta$$

$$A_{\text{eff}} = \pi * R_{\text{eff}}^2$$

This area is compared to the maximum area available for the exit cone to see if the exit diameter must be reduced, as

$$D_N = D_M - 2 * Tk$$

$$A_{\max} = (D_N/2)^2 * \pi$$

If A_{eff} is less than or equal to A_{\max} , the nozzle is properly sized and the routine proceeds with the weight calculations. If A_{eff} is greater than A_{\max} , the exit diameter must be reduced to

$$L_{\text{exit}} = L_{\text{exit}} * \cos(\text{BETA}) + (RE + TK) \sin(\text{BETA})$$

Reduction of the nozzle area to fit within the allowable area follows the geometry of Figure 6.

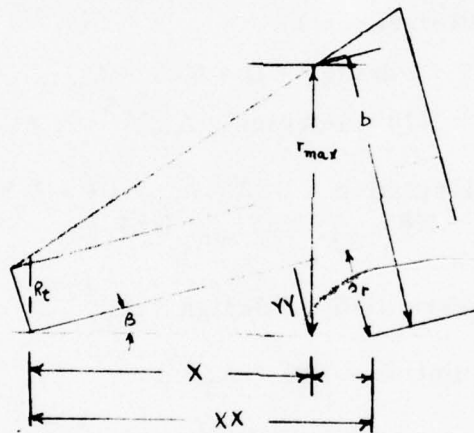

FIGURE 6

NOZZLE REDUCTION MODEL

$$R_{\max} = DN/Z$$

$$Y_1 = R_t / \cos \beta$$

$$X = \frac{R_{\max} - Y_1}{\tan(\phi + \beta)}$$

$$YY = X \tan \beta$$

$$XX = X + r_{\max} * \tan \beta$$

$$\delta_r = \frac{XX}{X} * YY$$

$$r_e = a - \delta_r - tk$$

$$L_{\text{exit}} = XX + (R_e + tk) * \sin \beta$$

Aft dome length

$$D_N = \sqrt{\frac{AT}{H} * N24} \quad \text{if } D_N \geq R_3, D_N = .8 * R_3$$

$$Z1 = \frac{\sqrt{R3^2 - DN^2}}{N23^2}$$

Entrance length

$$Y_E = DN - \sqrt{\frac{AT}{\pi}}$$

$$X1 = \sqrt{A_T - Y_E^2}$$

Nozzle length

$$XRN = Z1 + X1 + Lexit * PBELL$$

Nozzle weights are based on empirical equations originally developed by Aerojet (Reference 1).

$$\text{Boss} = N77 * P_{\text{design}} * D * N23 * A_T$$

$$\text{Exit Cone} = N79 * P_{\text{design}} * A_T^{1.5} * (\epsilon - 2.5) / \text{SIN } \emptyset$$

$$\text{Exit cone insulation} = N82 * A_T * (\epsilon - 2.5) / \text{SIN } \emptyset$$

$$* F_{S_y}^{N83} * P_c^{N83} * T_b^{N84}$$

$$\text{Throat insert} = N78 * P_{\text{design}} * A_T^{1.5}$$

$$\text{Throat insulation} = N81 * A_T^{.9}$$

$$\text{Throat sleeve} = N78 * P_{\text{design}} * A_T^{1.5}$$

4.2 Nozzle Inertia and CG Modeling

Moments of inertia and centers of gravity of the external booster nozzle subsystems are computed and compiled for output. Modeling assumptions are shown in Table II.

TABLE II

EXTERNAL NOZZLE MOI AND C.G. MODELING

<u>Component</u>	<u>Segment Model</u>	
Entrance Section	Truncated Cone Shell	
Throat Section	Cylindrical Shell	Includes misc. nozzle weights
Exit Section	Truncated Cone Shell	

APPENDIX E

INLET SIZING AND PERFORMANCE

TITLE:

INLET SIZING AND PERFORMANCE

Appendix E

NO. _____

DATE _____

TABLE OF CONTENTS

<u>Section</u>		<u>Page</u>
1.	SUMMARY	E-3
2.	DETAILED DISCUSSION.	E-3

LIST OF ILLUSTRATIONS

<u>Figure</u>		<u>Page</u>
1	Inlet Flow Field - Dual Aft	E-5-6
2	Inlet Flow Field - Bottom Centerline	E-7-8
3	Definition of Inlet Geometric Variables	E-10
4	Inlet Performance Characteristics-Ramjet-Dual Aft - M=1.75	E-12-13
5	Inlet Performance Characteristics-Ramjet-Dual Aft - M=2.00	E-14-15
6	Inlet Performance Characteristics-Dual Aft - M=2.25	E-16-17
7	Inlet Performance Characteristics - Ramjet- Dual Aft - M=2.50	E-18-19
8	Inlet Performance Characteristics - Ramjet- Bottom Centerline - M=1.75.	E-20-21
9	Inlet Performance Characteristics - Ramjet Bottom Centerline - M=2.00.	E-22-23
10	Inlet Performance Characteristics - Ramjet Bottom Centerline - M=2.25.	E-24-25

PREPARED BY H. L. Tellock

APPROVED BY L. D. Gregory (L.D.)

PAGE 1 OF 39

TABLE OF CONTENTS (Cont'd.)

<u>Figure</u>		<u>Page</u>
11	Inlet Performance Characteristics - Ramjet Bottom Centerline - M=2.50	E-26-27
12	Inlet Performance Characteristics - Combined Cycle - Bottom Centerline - M=2.50	E-28-29
13	Inlet Performance Characteristics - Turbojet - Bottom Centerline - Normal Shock.	E-30-31
14	Inlet Performance Characteristics - Turbojet - Bottom Centerline - 12 Deg. Ramp	E-32-33
15	Total Pressure Recovery - Dual Aft Inlet Design Mach Number of 2.5	E-34
16	Critical Mass Flow Rate - Dual Aft Inlet Design Mach Number of 2.5	E-35
17	Critical Additive Drag - Dual Aft, Inlet Design Mach Number of 2.5	E-36

LIST OF TABLES

<u>Table</u>		<u>Page</u>
I	Inlet Design Characteristics	E-9

APPENDIX E

INLET SIZING AND PERFORMANCE

1.0 SUMMARY

Two inlet subroutines were developed for the SEATIDE program. Subroutine INLETP determines the weight, pitch plane moment of inertia, and center of gravity for a given inlet size. Either a dual aft inlet system with the inlets located on the missile horizontal centerline, or a single inlet on the bottom centerline may be analyzed. Either inlet system uses a two-dimensional downward compressing inlet. The bottom centerline location is not considered a "chin" inlet because the inlet cannot extend forward of the tangency point between the missile forebody and the constant diameter cylindrical section. The inlet aspect ratio (ratio of width to height) can be specified. The program also calculates inlet wetted areas, projected areas, and boundary layer diverter heights required in other subroutines to calculate the inlet drag. This subroutine is used with propulsion systems that use a ramjet, turbojet, or combined cycle. The second subroutine is titled INLET. This subroutine is used only with the turbojet propulsion system. The subroutine calculates an inlet capture area at the specified design point. The program then determines the inlet mass flow ratio at desired off-design points. If the match point results in subcritical inlet operation, the inlet spillage drag is calculated, and, if supercritical operation is necessary, the resulting operating total pressure is calculated and the additive drag is equated to the critical additive drag. An indication of the need for supercritical operation is provided as optional output.

In addition to the two subroutines summarized above, inlet performance characteristics are provided for eleven (11) inlets. These performance characteristics were generated by an in-house computer program used extensively for inlet analyses. The pertinent inlet performance characteristics calculated are critical total pressure recovery, critical mass flow ratio, and critical additive drag.

2.0 DETAILED DISCUSSION

2.1 Inlet Performance Characteristics

The performance characteristics of the inlets were calculated assuming a two-dimensional, downward compressing, external compression inlet located in the local flow field created by the missile forebody. An inlet design Mach number and the desired compression surface angle(s) are specified, and the inlet geometry is determined. (Three compression ramp angles must be specified because of program input requirements).

Once the inlet design has been generated, the performance at specified off design points is determined, as follows. At the specified flight Mach number and vehicle angle of attack, the local Mach number, local angle of attack, and local total pressure recovery are determined from input tables. Oblique shock and normal shock relations are then combined with a control volume analysis to determine the inviscid throat total pressure recovery, and the critical mass flow ratio. The inviscid throat total pressure recovery is corrected for various losses such as shock, boundary layer, diffusion, and dump losses to arrive at a delivered critical total pressure recovery (PT_2/PT_0). Appropriate checks and logic are included to accommodate detached shocks and subsonic local flow fields. The specifics of this program, as applied to the SEATIDE airbreathing propulsion systems, are described below.

The local flow fields for the two inlet locations are tabulated in Figures 1 and 2 for the dual aft inlet and the bottom centerline inlet, respectively. The data shown are for six angles of attack (-5, 0, 5, 10, 15, and 20 degrees) and 14 flight Mach numbers (ML) at each angle of attack. Four local flow field properties are shown: BO, which is irrelevant to two-dimensional inlets; AO, the local angle of attack; PTO, the ratio of local total pressure to freestream total pressure; and MO, the local Mach number.

The design point geometric characteristics for the eleven (11) inlets are summarized in Table I. (See Figure 3 for a definition of the variables). Note that all distances are normalized by the inlet capture height, YC. As shown in Table I, eight (8) inlet designs are shown for the ramjet propulsion system. These designs are for inlet design Mach numbers of 1.75, 2.00, 2.25, and 2.50, with two possible inlet locations for each design Mach numbers. A single design for the combined cycle propulsion system is indicated, for the bottom centerline location. For the turbojet propulsion system, two inlet designs are indicated, both for the bottom centerline location. The first design is a normal shock inlet for cruise Mach numbers of 1.5 or less. The second inlet has a design Mach number of 2.0 and a single compression surface.

The rationale for selection of the number and magnitude of the compression surfaces is as follows. For the ramjet propulsion system, past experience has shown that the inlet for an accelerating ramjet must be sized at the takeover condition. The minimum inlet size is obtained by having the maximum critical mass flow ratio, zero additive drag, and maximum total pressure recovery at the sizing point. The first two (2) items are satisfied by equating the inlet design Mach number to the ramjet takeover Mach number. The third item is dependent upon the number of compression surfaces and the relative deflection of each. Theoretically, the total pressure recovery increases as the number of compression surfaces increases. However, the gain from additional compression surfaces diminishes rapidly with decreasing design Mach number. Thus, the Mach number 1.75 design inlet has a single compression surface; the Mach number 2.0 design inlet has two compression

FIGURE 1
INLET FLOW FIELD - DUAL AFT

AV	4	7M	BO	AO	PTO	MO	LOCAL CONDITIONS FOR BETA=90.DEG				Angles of Attack = α	
			-5.		0.		5.	10.	15.	20.		
9	9	9	9	9	9	9						} Mach Nos.
			24.									
			1.5		2.0		2.5	3.0	3.5	4.0		} AO
			4.5		4.75		5.					
			0.		0.		0.	0.	0.	0.		} MO
			0.		0.							
			-3.6		-3.7		-3.8	-3.9	-4.0	-4.1		} $\alpha = 0^\circ$
			-4.2		-4.25		4.3					
			1.		1.		.998	.993	.985	.954		} $\alpha = 10^\circ$
			.925		.911		.897					
			1.60		2.10		2.58	3.08	3.60	4.11		}
			4.62		4.88		5.14					
			1.5		2.0		2.5	3.0	3.5	4.0		}
			4.5		4.75		5.					
			0.		0.		0.	0.	0.	0.		}
			0.		0.							
			0.7		0.6		0.5	0.4	0.3	0.2		}
			0.1		0.							
			1.		1.		.996	.986	.970	.954		}
			.940		.933		.926					
			1.58		2.07		2.55	3.04	3.55	4.04		}
			4.53		4.77		5.01					
			1.5		2.0		2.5	3.0	3.5	4.0		}
			4.5		4.75		5.					
			0.		0.		0.	0.	0.	0.		}
			0.		0.							
			6.5		6.5		6.5	6.1	5.9	5.6		}
			5.3		5.15		5.					
			1.0		1.0		.972	.964	.948	.952		}
			.969		.986		.988					
			1.59		2.07		2.54	3.03	3.52	3.98		}
			4.45		4.69		4.93					
			1.5		2.0		2.5	3.0	3.5	4.0		}
			4.5		4.75		5.					
			0.		0.		0.	0.	0.	0.		}
			0.		0.							
			14.4		13.1		11.7	10.2	9.5	9.0		}
			8.6		8.3		8.					
			.992		.976		.960	.950	.948	.955		}
			.984		.988		.992					
			1.58		2.04		2.48	2.94	3.40	3.85		}
			4.30		4.53		4.76					

FIGURE 1-CONTINUED

1.5	2.0	2.5	3.	3.5	4.0	} $\alpha = 15^\circ$
4.5	4.75	5.				
0.	0.	0.	0.	0.	0.	
0.	0.					
21.0	18.	15.5	13.5	12.2	11.6	
11.0	10.7	10.4				
.990	.978	.952	.927	.892	.875	
.870	.868	.866				
1.62	2.0	2.38	2.78	3.18	3.58	
3.97	4.18	4.39				
1.5	2.0	2.5	3.0	3.5	4.0	} $\alpha = 20^\circ$
4.5	4.75	5.				
0.	0.	0.	0.	0.	0.	
0.	0.					
25.4	21.0	16.8	16.4	15.	14.1	
13.4	12.9	12.4				
.985	.975	.945	.882	.824	.777	
.748	.745	.742				
1.64	1.95	2.27	2.60	2.94	3.28	
3.58	3.72	3.86				
1.5	2.0	2.5	3.0	3.5	4.0	} $\alpha = 24^\circ$
4.5	4.75	5.				
0.	0.	0.	0.	0.	0.	
26.4	23.8	21.2	18.0	17.3	16.2	
15.5	14.9	14.3				
.980	.960	.921	.859	.784	.716	
.662	.637	.612				
1.62	1.91	2.20	2.50	2.78	3.04	
3.31	3.44	3.57				

FIGURE 2
INLET FLOW FIELD - BOTTOM CENTERLINE

AV	4	6M	BO	AO	PTO	NO	LOCAL CONDITIONS FOR BETA=ZERO				Angles of Attack = α	
							5.	10.	15.	20.		
141414141414			-5.				0.					
			.48			.7	.9	1.1	1.3	1.4	Mach Nos.	
ML			1.5		2.0	2.5	3.	3.5	4.0			
ML			4.5		5.0							
BO			0.		0.	0.	0.	0.	0.	0.	BO	
BO			0.		0.							
			.70		.65	.60	.56	.52	.5	.5	AO	
AO			.5		.4	.4	.3	.2	.2			
AO			.1		.1							
			1.0		1.0	1.0	1.0	1.0	1.0	1.0	PTO	
PTO			1.0		.998	.996	.990	.980	.965			
PTO			.935		.900							
			.60		.84	1.06	1.26	1.45	1.54	1.54	MO	
MO			1.64		2.07	2.58	3.13	3.72	4.28			
MO			4.88		5.40							
			.48		.7	.9	1.1	1.3	1.4	1.4	Mach Nos.	
ML			1.5		2.0	2.5	3.	3.5	4.			
ML			4.5		5.							
BO			0.		0.	0.	0.	0.	0.	0.	BO	
BO			0.		0.							
			1.2		1.15	1.10	1.02	.97	.94	.94	AO	
AO			.9		.8	.8	.65	.5	.5			
AO			.5		.4							
			1.0		1.0	1.0	1.0	1.0	1.0	1.0	PTO	
PTO			1.0		.995	.992	.986	.975	.956			
PTO			.921		.892							
			.56		.81	1.02	1.21	1.40	1.49	1.49	MO	
MO			1.58		2.03	2.52	3.04	3.58	4.10			
MO			4.60		5.02							
			.48		.7	.9	1.1	1.3	1.4	1.4	Mach Nos.	
ML			1.5		2.0	2.5	3.0	3.5	4.0			
ML			4.5		5.							
BO			0.		0.	0.	0.	0.	0.	0.	BO	
BO			0.		0.							
			5.35		4.80	4.40	3.90	3.55	3.4	3.4	AO	
AO			3.2		2.5	2.0	1.85	1.7	1.65			
AO			1.6		1.5							
			.999		.9985	.9975	.996	.994	.993	.993	PTO	
PTO			.992		.987	.983	.976	.960	.930			
PTO			.885		.852							
			.55		.79	.99	1.19	1.37	1.46	1.46	MO	
MO			1.56		2.0	2.46	2.94	3.44	3.91			
MO			4.30		4.62							

FIGURE 2-CONTINUED

	.48	.7	.9	1.1	1.3	1.4
ML	1.5	2.	2.5	3.	3.5	4.
ML	4.5	5.				
BO	0.	0.	0.	0.	0.	0.
BO	0.	0.				
	10.0	9.55	8.90	8.30	7.60	7.3
AO	7.	5.5	4.0	3.5	3.0	2.75
AO	2.5	2.3				
	.9835	.983	.982	.981	.9795	.979
PTO	.978	.975	.968	.956	.938	.900
PTO	.843	.786				
	.54	.76	.96	1.15	1.32	1.42
MO	1.52	1.93	2.32	2.79	3.24	3.65
MO	3.98	4.23				
	.48	.7	.9	1.1	1.3	1.4
ML	1.5	2.0	2.5	3.0	3.5	4.0
ML	4.5	5.0				
BO	0.	0.	0.	0.	0.	0.
BO	0.	0.				
	15.0	14.0	12.5	11.2	10.5	9.5
AO	9.	7.	5.8	5.1	4.5	4.15
AO	3.8	3.4				
	.9745	.973	.972	.970	.9685	.9675
PTO	.967	.961	.955	.945	.919	.875
PTO	.798	.727				
	.50	.72	.90	1.09	1.27	1.35
MO	1.42	1.80	2.20	2.62	3.04	3.41
MO	3.69	3.89				
	.48	.7	.9	1.1	1.3	1.4
ML	1.5	2.0	2.5	3.0	3.5	4.0
ML	4.5	5.0				
BO	0.	0.	0.	0.	0.	0.
BO	0.	0.				
	20.0	18.5	16.0	13.5	11.6	10.8
AO	10.2	3.	7.3	6.6	6.0	5.5
AO	5.0	4.5				
	.9635	.962	.9605	.959	.9575	.957
PTO	.956	.951	.946	.935	.903	.847
PTO	.757	.677				
	.47	.67	.85	1.03	1.20	1.28
MO	1.37	1.71	2.07	2.44	2.84	3.17
MO	3.42	3.59				

$\alpha = 10^\circ$

$\alpha = 15^\circ$

$\alpha = 20^\circ$

TABLE I
INLET DESIGN CHARACTERISTICS

VARIABLE	RAMJET										TURBOJET			
	DUAL AFT					BOTTOM CENTERLINE					Combined Cycle	Normal Shock	Single Ramp	
	1.75	2.00	2.25	2.50	1.75	2.00	2.25	2.50	0.	2.50				
MACH NO.	1.75	2.00	2.25	2.50	1.75	2.00	2.25	2.50	0.	2.50				
XR1	0.	0.	0.	0.	0.	0.	0.	0.	0.	0.	0.	0.	0.	0.
XR2	.50176	.84624	.84091	.96014	.46003	.79679	.78347	.90260	1.01999	.15798	.44956			
XR3	.50247	1.12748	1.35855	1.49054	.46072	1.07707	1.30159	1.43668	1.29021	.15979	.45018			
XR4	1.04218	1.47934	1.77985	1.88551	1.03691	1.44553	1.73988	1.84857	1.63860	.54885	1.28535			
XC	.86663	1.24475	1.52599	1.64497	.86108	1.2098	1.48631	1.60957	1.40901	.54502	1.13067			
YR1	0.	0.	0.	0.	0.	0.	0.	0.	0.	0.	0.			
YR2	.11584	.15531	.13319	.16930	.10621	.14624	.12409	.15915	.243	.00055	.09556			
YR3	.11600	.26610	.30941	.37396	.10637	.25664	.30047	.36523	.39278	.00056	.09569			
YR4	.24081	.40477	.54390	.63242	.23960	.40186	.54442	.63477	.58598	.00205	.27351			
YC	1.	1.	1.	1.	1.	1.	1.	1.	1.	1.	1.			
XT	.77923	.63979	.52199	.43929	.78046	.64292	.52139	.43648	.47342	.99796	.74277			
ZMACHT	1.22667	1.16137	1.09533	1.14466	1.25440	1.17423	1.11888	1.7703	1.30666	1.07298	.52336			
YRANG 1	13.00	10.40	9.00	10.00	13.00	10.40	9.00	10.00	13.4	.20	12.			
YRANG 2	.01	11.10	9.80	11.10	.01	11.10	9.80	11.10	15.6	.01	.01			
YRANG 3	.01	.01	10.30	12.10	.01	.01	10.30	12.10	.01	.01	.01			
DSMACH	1.75	2.00	2.25	2.50	1.75	2.00	2.25	2.50	2.5	1.50	2.00			

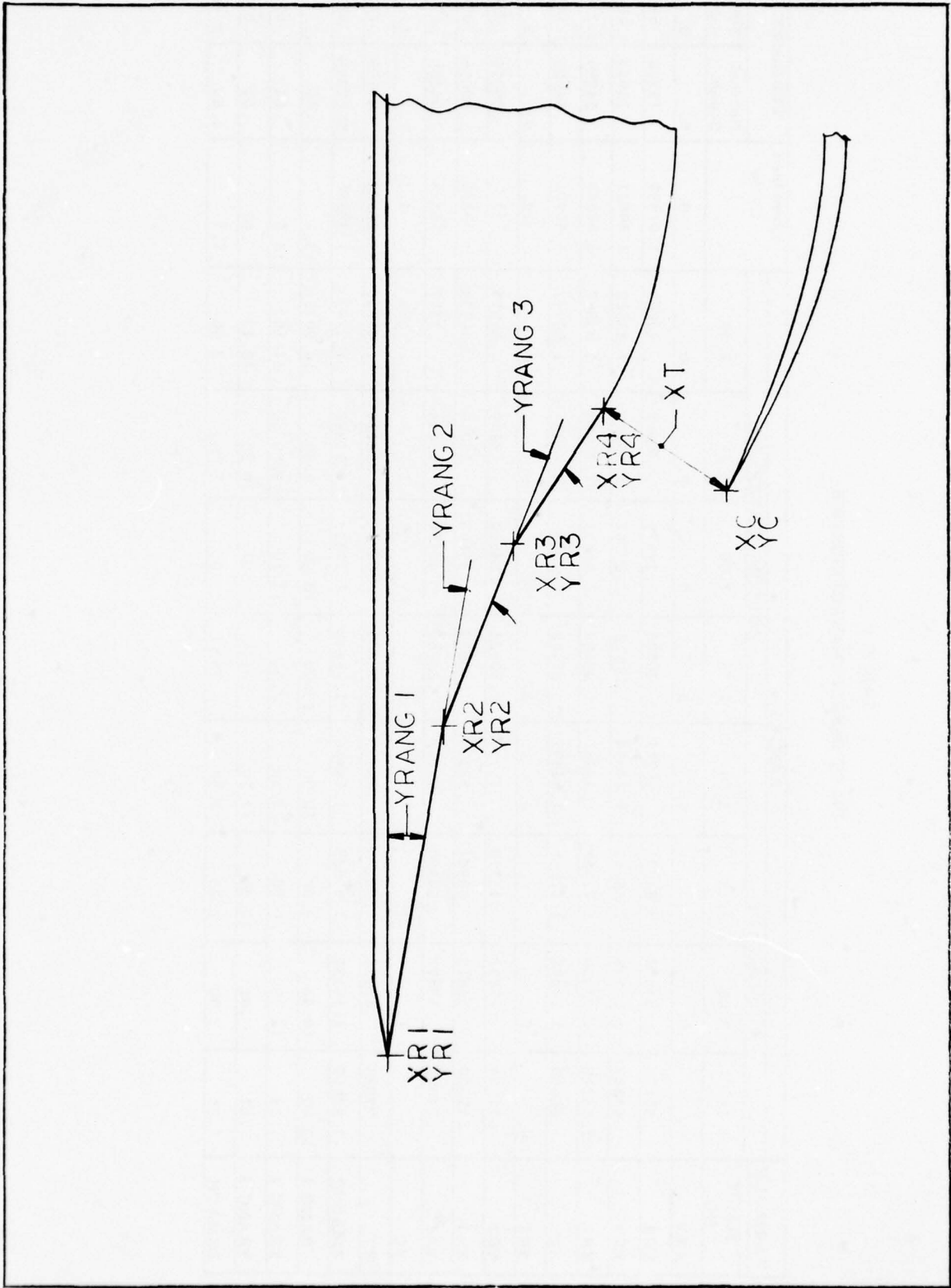

FIGURE 3. DEFINITION OF INLET GEOMETRIC VARIABLES

surfaces; and the Mach number 2.25 and 2.50 design inlets have three compression surfaces. The magnitudes of the compression surface angles correspond to those which will give maximum theoretical total pressure recovery at the design Mach number.

For the combined cycle, the design selected is a compromise between the low speed requirements wherein the bipropellant rocket gas generators provide most of the thrust and little air is required, and the higher speeds wherein the ramjet system is used. The design shown was selected after evaluating inlets with design Mach numbers of 2.25, 2.50 and 2.75.

For the turbojet propulsion system, the two designs represent the effect of cruise Mach number. For cruise Mach number of 1.5 or less, a normal shock inlet is the generally accepted choice. Although Table I indicates an inlet with three compression surfaces, this is only to satisfy the program input requirements. Note that the total amount of compression is only 0.22 degrees. For the Mach 2.0 cruise missile, a fixed geometry single compression surface inlet was selected. A higher performing double compression surface inlet was considered, but it was rejected because it would probably require variable geometry to satisfy engine airflow demands. Compression surface angles of 8.0, 12.0, and 16.5 degrees were evaluated to determine the best match with the engine. The selected inlet was the best compromise.

The resultant inlet performance characteristics for the eleven inlets are tabulated in Figures 4 through 14. Figures 4 through 7 present data for the dual aft ramjet inlet systems; Figures 8 through 11 present data for the bottom centerline ramjet inlet systems; Figure 12 presents the data for the combined cycle inlet (bottom centerline); and Figures 13 and 14 present the data for the turbojet inlet systems (bottom centerline). Figures 15, 16, and 17 present in curve form a typical set of installed performance data. The data are for a dual aft inlet with a design Mach number of 2.5. The inlet has three compression surfaces with angles of 10.0, 11.1, and 12.1 degrees. (A scaled drawing of this inlet has been presented earlier as Figure 3).

Figure 15 presents the inlet critical total pressure recovery as a function of flight Mach number and vehicle angle of attack. At large angles of attack, the inlet recovery is relatively insensitive to Mach number. This is due to the forebody effect; the local Mach number is substantially less than freestream, and shock detachment may occur. As the flight Mach number is increased at a constant angle of attack, the local Mach number becomes high enough to permit shock attachment and the characteristic decrease in recovery with increasing Mach number is noted. For example, at seven degrees angle of attack, the characteristic reduction starts at a flight Mach number of about 2.75; at 16 degrees, the reduction starts at about Mach number 3.25.

FIGURE 4

INLET PERFORMANCE CHARACTERISTICS - RAMJET-DUAL AFT-M=1.75
 INLET DESIGN MACH NO.=1.75, DUAL AFT, SINGLE RAMP

RAMJET*

AV	3 8 MACH	PT3	AOAC	CDA	EXT.COMPR.	13.00,	0.01,	0.01	DEG.RAMPS,	1.75
AV	-5.00000	-2.00000	1.00000	4.00000	7.00000	10.00000				
	13.00000	16.00000								
1414141414141414										
AM	-5.	1.75000	2.00000	2.25000	2.50000	2.75000	3.00000			
		3.25000	3.50000	3.75000	4.00000	4.25000	4.50000			
		4.75000	5.00000							
PT3		0.73673	0.62895	0.54102	0.44980	0.36605	0.29575			
		0.23576	0.18783	0.14874	0.11808	0.09418	0.07542			
		0.06047	0.05545							
AOAC		0.87426	0.86535	0.86667	0.87071	0.86681	0.86383			
		0.85211	0.84122	0.82506	0.80939	0.79496	0.78084			
		0.76430	0.750							
CDA		-0.00000	-0.00000	-0.00000	-0.00000	-0.00000	-0.00000			
		-0.00001	-0.00001	-0.00001	-0.00001	-0.00001	-0.00001			
		-0.00002	-0.00002							
AM	-2.	1.75000	2.00000	2.25000	2.50000	2.75000	3.00000			
		3.25000	3.50000	3.75000	4.00000	4.25000	4.50000			
		4.75000	5.00000							
PT3		0.75741	0.66447	0.56554	0.47170	0.38528	0.31222			
		0.24927	0.19880	0.15903	0.12750	0.10267	0.08299			
		0.06741	0.05797							
AOAC		0.92278	0.91700	0.91875	0.92302	0.92039	0.91850			
		0.90624	0.89461	0.88577	0.87703	0.86923	0.86140			
		0.85399	0.840							
CDA		-0.00000	-0.00000	-0.00000	-0.00000	-0.00001	-0.00001			
		-0.00001	-0.00001	-0.00001	-0.00001	-0.00001	-0.00002			
		0.0	-0.00002							
AM	1.	1.75000	2.00000	2.25000	2.50000	2.75000	3.00000			
		3.25000	3.50000	3.75000	4.00000	4.25000	4.50000			
		4.75000	5.00000							
PT3		0.76927	0.68535	0.58619	0.49015	0.40181	0.32651			
		0.26153	0.20914	0.16923	0.13721	0.11172	0.09130			
		0.07518	0.06203							
AOAC		0.97017	0.96754	0.96837	0.97162	0.96972	0.96843			
		0.95727	0.94630	0.94730	0.94786	0.94938	0.95059			
		0.95500	0.95703							
CDA		-0.00000	-0.00000	-0.00000	-0.00000	-0.00000	-0.00000			
		-0.00001	-0.00001	-0.00001	-0.00001	-0.00003	-0.00002			
		-0.00002	-0.00002							
AM	4.	1.75000	2.00000	2.25000	2.50000	2.75000	3.00000			
		3.25000	3.50000	3.75000	4.00000	4.25000	4.50000			
		4.75000	5.00000							
PT3		0.75178	0.67631	0.59839	0.50078	0.41215	0.33577			
		0.27076	0.21737	0.17883	0.14700	0.12142	0.10061			
		0.08405	0.06965							
AOAC		0.98416	1.01430	1.01103	1.01033	1.00799	1.00620			
		0.99982	0.97353	1.00786	1.02176	1.03733	1.05248			
		1.07184	1.07792							
CDA		0.01929	-0.00000	-0.00000	-0.00000	-0.00000	-0.00000			
		-0.00001	-0.00001	-0.00001	-0.00001	-0.00001	-0.00002			
		-0.00002	-0.00002							

FIGURE 4-CONTINUED

AM	7.	1.75000	2.00000	2.25000	2.50000	2.75000	3.00000
		3.25000	3.50000	3.75000	4.00000	4.25000	4.50000
		4.75000	5.00000				
PT3		0.72996	0.68449	0.60613	0.51448	0.42752	0.35077
		0.28605	0.23256	0.19230	0.15915	0.13281	0.11113
		0.09295	0.07733				
AOAC		0.96176	1.06104	1.06179	1.06538	1.06641	1.06761
		1.07042	1.07204	1.09473	1.11599	1.14361	1.17067
		1.19266	1.20315				
CDA		0.08657	-0.00000	-0.00000	-0.00000	-0.00000	-0.00001
		-0.00001	-0.00001	-0.00001	-0.00001	-0.00001	-0.00000
		-0.00000	-0.00003				
AM	10.	1.75000	2.00000	2.25000	2.50000	2.75000	3.00000
		3.25000	3.50000	3.75000	4.00000	4.25000	4.50000
		4.75000	5.00000				
PT3		0.72605	0.65261	0.59636	0.52525	0.44383	0.36839
		0.30480	0.25108	0.20849	0.17316	0.14572	0.12288
		0.10230	0.08545				
AOAC		0.95661	1.04652	1.11550	1.12963	1.13718	1.14435
		1.16036	1.17550	1.20205	1.22763	1.26717	1.30606
		1.32300	1.33886				
CDA		0.15882	0.02506	-0.00000	-0.00000	-0.00000	-0.00001
		-0.00001	-0.00001	-0.00001	-0.00001	0.0	-0.00000
		-0.00003	-0.00001				
AM	13.	1.75000	2.00000	2.25000	2.50000	2.75000	3.00000
		3.25000	3.50000	3.75000	4.00000	4.25000	4.50000
		4.75000	5.00000				
PT3		0.72605	0.66112	0.58686	0.53437	0.46538	0.39388
		0.32883	0.27273	0.22791	0.19026	0.16071	0.13592
		0.11362	0.09522				
AOAC		0.95661	1.06016	1.16913	1.21382	1.23751	1.26034
		1.28404	1.30549	1.34076	1.37400	1.42160	1.46763
		1.49069	1.51180				
CDA		0.19855	0.07069	-0.00505	-0.00000	-0.00000	-0.00001
		-0.00001	-0.00001	-0.00001	-0.00001	-0.00001	-0.00001
		-0.00001	-0.00002				
AM	16.	1.75000	2.00000	2.25000	2.50000	2.75000	3.00000
		3.25000	3.50000	3.75000	4.00000	4.25000	4.50000
		4.75000	5.00000				
PT3		0.72624	0.66946	0.60045	0.53001	0.47908	0.41607
		0.35183	0.29458	0.24788	0.20806	0.17702	0.15062
		0.12760	0.10826				
AOAC		0.95685	1.07353	1.19622	1.32800	1.34341	1.38310
		1.41814	1.44931	1.49484	1.53684	1.59932	1.65908
		1.70565	1.74911				
CDA		0.22983	0.14469	0.01987	0.	0.	0.
		-0.00001	-0.00001	-0.00001	-0.00001	-0.00001	-0.00002
		-0.00001	-0.00001				

FIGURE 5
 INLET PERFORMANCE CHARACTERISTICS - RAMJET-DUAL AFT-M=2.00
 INLET DESIGN MACH NO.=2.00, DUAL AFT, DOUBLE RAMP)RAMJET*

AV	3 8 MACH	PT3	AOAC	CDA	EXT.COMPR.	10.40	11.10	0.01	DEG.RAMPS,	2.00
AV	-5.	1.75000	2.00000	2.25000	2.50000	2.75000	3.00000			
		3.25000	3.50000	3.75000	4.00000	4.25000	4.50000			
		4.75000	5.00000							
PT3		0.79406	0.72395	0.62173	0.52149	0.42705	0.34658			
		0.27722	0.22141	0.17564	0.13964	0.11148	0.08934			
		0.07167	0.06829							
AOAC		0.82950	0.84294	0.84389	0.84750	0.84339	0.84016			
		0.82845	0.81754	0.80153	0.78600	0.77169	0.75769			
		0.74135	0.720							
CDA		0.00246	-0.00000	-0.00000	-0.00000	-0.00000	-0.00000			
		-0.00001	-0.00001	-0.00001	-0.00001	-0.00001	-0.00001			
		0.00000	-0.00002							
AM	-2.	1.75000	2.00000	2.25000	2.50000	2.75000	3.00000			
		3.25000	3.50000	3.75000	4.00000	4.25000	4.50000			
		4.75000	5.00000							
PT3		0.79492	0.75569	0.65590	0.55329	0.45538	0.37099			
		0.29737	0.25784	0.19065	0.15309	0.12341	0.09984			
		0.08113	0.07087							
AOAC		0.85743	0.91010	0.91153	0.91544	0.91252	0.91033			
		0.89787	0.88604	0.87698	0.86802	0.86000	0.85196			
		0.84415	0.840							
CDA		0.03078	-0.00000	-0.00000	-0.00000	-0.00000	-0.00001			
		-0.00001	-0.00001	-0.00001	-0.00000	-0.00001	-0.00002			
		-0.00001	-0.00000							
AM	1.	1.75000	2.00000	2.25000	2.50000	2.75000	3.00000			
		3.25000	3.50000	3.75000	4.00000	4.25000	4.50000			
		4.75000	5.00000							
PT3		0.79073	0.77414	0.68283	0.57970	0.47976	0.39233			
		0.31571	0.25329	0.20542	0.16681	0.13598	0.11121			
		0.09160	0.07562							
AOAC		0.85540	0.97861	0.97921	0.98225	0.97984	0.97805			
		0.96642	0.95518	0.95557	0.95572	0.95682	0.95762			
		0.96139	0.96326							
CDA		0.12206	-0.00000	-0.00000	-0.00000	-0.00000	-0.00001			
		-0.00001	-0.00001	-0.00001	-0.00001	-0.00001	-0.00001			
		-0.00001	-0.00002							
AM	4.	1.75000	2.00000	2.25000	2.50000	2.75000	3.00000			
		3.25000	3.50000	3.75000	4.00000	4.25000	4.50000			
		4.75000	5.00000							
PT3		0.77673	0.75143	0.69271	0.59356	0.49505	0.40662			
		0.32971	0.26632	0.21913	0.18044	0.14921	0.12373			
		0.10340	0.08570							
AOAC		0.84025	0.98903	1.04391	1.04314	1.03974	1.03691			
		1.02982	1.02282	1.03681	1.05034	1.06557	1.08032			
		1.09932	1.10479							
CDA		0.19902	0.06676	-0.00000	-0.00000	-0.00001	-0.00000			
		-0.00001	-0.00001	-0.00001	-0.00001	-0.00000	-0.00001			
		-0.00004	-0.00001							

FIGURE 5-CONTINUED

AM	7.	1.75000	2.00000	2.25000	2.50000	2.75000	3.00000
		3.25000	3.50000	3.75000	4.00000	4.25000	4.50000
		4.75000	5.00000				
PT3		0.72996	0.72535	0.68307	0.60231	0.51171	0.42480
		0.34889	0.28500	0.23638	0.19604	0.16384	0.13722
		0.11484	0.07555				
AOAC		0.78966	0.95503	1.11693	1.11913	1.11784	1.11669
		1.11848	1.11985	1.14156	1.16258	1.19028	1.21735
		1.23883	1.24832				
CDA		0.26100	0.21107	0.02142	-0.00000	-0.00000	-0.00001
		-0.00001	-0.00001	-0.00001	-0.00001	-0.00001	-0.00000
		-0.00001	-0.00003				
AM	10.	1.75000	2.00000	2.25000	2.50000	2.75000	3.00000
		3.25000	3.50000	3.75000	4.00000	4.25000	4.50000
		4.75000	5.00000				
PT3		0.72605	0.65261	0.65410	0.58575	0.52326	0.44327
		0.37053	0.30723	0.25618	0.21338	0.17993	0.15193
		0.12659	0.10578				
AOAC		0.78543	0.85926	1.06991	1.20463	1.20843	1.21170
		1.22657	1.24046	1.26692	1.29227	1.33257	1.37209
		1.38778	1.40228				
CDA		0.34321	0.29522	0.21365	0.00372	-0.00000	-0.00000
		-0.00001	-0.00000	-0.00001	-0.00001	-0.00000	-0.00001
		-0.00001	-0.00001				
AM	13.	1.75000	2.00000	2.25000	2.50000	2.75000	3.00000
		3.25000	3.50000	3.75000	4.00000	4.25000	4.50000
		4.75000	5.00000				
PT3		0.72605	0.66112	0.61055	0.60568	0.52715	0.46644
		0.39606	0.33177	0.27890	0.23380	0.19805	0.16783
		0.14051	0.11787				
AOAC		0.78543	0.87045	0.99867	1.24603	1.32800	1.34700
		1.36896	1.38040	1.42402	1.45738	1.50600	1.55281
		1.57491	1.59489				
CDA		0.40573	0.35138	0.30521	0.18660	-0.00000	-0.00000
		-0.00001	-0.00000	-0.00000	-0.00001	-0.00001	-0.00001
		-0.00001	-0.00001				
AM	16.	1.75000	2.00000	2.25000	2.50000	2.75000	3.00000
		3.25000	3.50000	3.75000	4.00000	4.25000	4.50000
		4.75000	5.00000				
PT3		0.72624	0.66946	0.60045	0.57234	0.55877	0.47489
		0.41620	0.35446	0.30100	0.25423	0.21721	0.18539
		0.15743	0.13380				
AOAC		0.78563	0.88143	0.98216	1.17744	1.45510	1.49085
		1.52416	1.55305	1.59944	1.64190	1.70621	1.76741
		1.81414	1.85737				
CDA		0.46199	0.40328	0.35232	0.31405	0.14902	-0.00000
		-0.00000	-0.00000	-0.00000	-0.00001	-0.00001	-0.00002
		-0.00002	-0.00001				

FIGURE 6
 INLET PERFORMANCE CHARACTERISTICS - RAMJET-DUAL AFT-M=2.25
 INLET DESIGN MACH NO.=2.25, DUAL AFT, TRIPLE RAMP)RAMJET*

AV	3.8 MACH	PT3	AOAC	CDA	EXT.COMPR.	9.00,	9.80,	10.30	DEG.RAMPS,	2.25
AV	-5.00000	-2.00000	1.00000	4.00000	7.00000	10.00000				
	13.00000	16.00000								
1414141414141414										
AM	-5.	1.75000	2.00000	2.25000	2.50000	2.75000	3.00000			
		3.25000	3.50000	3.75000	4.00000	4.25000	4.50000			
		4.75000	5.00000							
PT3		0.80340	0.78661	0.71218	0.60538	0.49983	0.40777			
		0.32734	0.26206	0.20820	0.16566	0.13231	0.10605			
		0.08505	0.08154							
AOAC		0.70908	0.81680	0.82696	0.83024	0.82596	0.82256			
		0.81085	0.74993	0.78403	0.76861	0.75438	0.74047			
		0.72427	0.700							
CDA		0.10070	0.01116	-0.00000	-0.00000	-0.00000	0.0			
		-0.00001	-0.00001	-0.00001	-0.00000	-0.00002	-0.00001			
		-0.00001	-0.00001							
AM	-2.	1.75000	2.00000	2.25000	2.50000	2.75000	3.00000			
		3.25000	3.50000	3.75000	4.00000	4.25000	4.50000			
		4.75000	5.00000							
PT3		0.80353	0.78870	0.75128	0.64559	0.53673	0.43992			
		0.35402	0.28384	0.22783	0.18307	0.14759	0.11937			
		0.09693	0.08481							
AOAC		0.70920	0.84716	0.90616	0.90981	0.90667	0.90426			
		0.89165	0.87966	0.87044	0.86132	0.85313	0.84493			
		0.83684	0.825							
CDA		0.15673	0.03820	-0.00000	-0.00000	-0.00000	-0.00001			
		-0.00001	-0.00001	-0.00001	-0.00001	-0.00000	-0.00002			
		-0.00000	-0.00000							
AM	1.	1.75000	2.00000	2.25000	2.50000	2.75000	3.00000			
		3.25000	3.50000	3.75000	4.00000	4.25000	4.50000			
		4.75000	5.00000							
PT3		0.79440	0.78832	0.77117	0.67590	0.56713	0.46727			
		0.37771	0.30382	0.24669	0.20041	0.16333	0.13348			
		0.10982	0.09054							
AOAC		0.70113	0.84682	0.98727	0.99015	0.98737	0.98520			
		0.97322	0.96164	0.96172	0.96156	0.96236	0.96285			
		0.95615	0.96788							
CDA		0.22029	0.14664	-0.00000	-0.00000	-0.00000	-0.00000			
		-0.00001	-0.00001	-0.00001	-0.00001	-0.00001	-0.00001			
		-0.00000	-0.00001							
AM	4.	1.75000	2.00000	2.25000	2.50000	2.75000	3.00000			
		3.25000	3.50000	3.75000	4.00000	4.25000	4.50000			
		4.75000	5.00000							
PT3		0.78434	0.77359	0.74799	0.68063	0.58236	0.48373			
		0.39454	0.27967	0.26336	0.21694	0.17932	0.14855			
		0.12396	0.11255							
AOAC		0.69226	0.82109	0.99821	1.06754	1.06335	1.05975			
		1.05213	1.04461	1.05835	1.07160	1.08657	1.10104			
		1.11976	1.12477							
CDA		0.33352	0.24444	0.11522	-0.00000	-0.00000	-0.00000			
		-0.00001	-0.00001	-0.00001	-0.00001	-0.00000	-0.00001			
		-0.00001	-0.00001							

FIGURE 6-CONTINUED

AM	7.	1.75000	2.00000	2.25000	2.50000	2.75000	3.00000
		3.25000	3.50000	3.75000	4.00000	4.25000	4.50000
		4.75000	5.00000				
PT3		0.74628	0.73725	0.71747	0.68812	0.58942	0.50051
		0.41499	0.34064	0.28318	0.23506	0.19642	0.16436
		0.13736	0.11409				
AOAC		0.65866	0.79196	0.95749	1.15498	1.15609	1.15320
		1.15423	1.15481	1.17640	1.19723	1.22499	1.25207
		1.27317	1.28192				
CDA		0.41763	0.38799	0.26739	0.08436	-0.00000	-0.00001
		-0.00001	-0.00001	-0.00001	-0.00001	-0.00001	0.0
		-0.00001	-0.00001				
AM	10.	1.75000	2.00000	2.25000	2.50000	2.75000	3.00000
		3.25000	3.50000	3.75000	4.00000	4.25000	4.50000
		4.75000	5.00000				
PT3		0.72605	0.68276	0.67036	0.65557	0.59391	0.51078
		0.43527	0.36421	0.30502	0.25459	0.21480	0.18131
		0.15094	0.12595				
AOAC		0.64081	0.75343	0.89461	1.10035	1.26142	1.26180
		1.27582	1.23877	1.31516	1.34036	1.38122	1.42120
		1.43597	1.44946				
CDA		0.50172	0.49810	0.43397	0.28102	0.05650	-0.00001
		-0.00000	-0.00000	-0.00000	-0.00001	-0.00000	-0.00001
		-0.00001	-0.00001				
AM	13.	1.75000	2.00000	2.25000	2.50000	2.75000	3.00000
		3.25000	3.50000	3.75000	4.00000	4.25000	4.50000
		4.75000	5.00000				
PT3		0.72605	0.66112	0.63853	0.62412	0.61074	0.52379
		0.45393	0.38803	0.32899	0.27707	0.23526	0.19956
		0.16709	0.14009				
AOAC		0.64081	0.71018	0.85213	1.04755	1.29760	1.41145
		1.43213	1.45006	1.48594	1.51940	1.56877	1.61617
		1.63756	1.65667				
CDA		0.58341	0.54343	0.56852	0.43640	0.26330	0.03720
		-0.00001	-0.00001	-0.00001	-0.00001	-0.00001	-0.00001
		-0.00002	-0.00001				
AM	16.	1.75000	2.00000	2.25000	2.50000	2.75000	3.00000
		3.25000	3.50000	3.75000	4.00000	4.25000	4.50000
		4.75000	5.00000				
PT3		0.72624	0.66946	0.60045	0.59824	0.58163	0.56501
		0.46918	0.40299	0.34902	0.29778	0.25583	0.21906
		0.18638	0.15853				
AOAC		0.64093	0.71913	0.80132	1.00412	1.23575	1.52303
		1.60302	1.63022	1.67724	1.72005	1.78572	1.84799
		1.89483	1.97790				
CDA		0.65703	0.62285	0.62761	0.62771	0.44880	0.25179
		0.05662	-0.00001	-0.00000	-0.00001	-0.00000	-0.00002
		-0.00001	-0.00001				

FIGURE 7
 INLET PERFORMANCE CHARACTERISTICS - RAMJET-DUAL AFT-M=2.50
 INLET DESIGN MACH NO.=2.50, DUAL AFT, TRIPLE RAMP)RAMJET*

AV	3 8 MACH	PT3	AOAC	CDA	EXT.COMPR.	10.00	11.10	12.10	DEG.RAMPS, 2.50
AV	-5.00000	-2.00000	1.00000	4.00000	7.00000	10.00000			
	13.00000	16.00000							
1414141414141414									
AM	-5.	1.75000	2.00000	2.25000	2.50000	2.75000	3.00000		
		3.25000	3.50000	3.75000	4.00000	4.25000	4.50000		
		4.75000	5.00000						
PT3		0.80130	0.78337	0.75847	0.67770	0.56557	0.46385		
		0.37358	0.29966	0.23832	0.18970	0.15151	0.12138		
		0.09728	0.09177						
AOAC		0.59518	0.70818	0.79689	0.82192	0.81859	0.81511		
		0.80340	0.79248	0.77662	0.76125	0.74705	0.73318		
		0.71705	0.700						
CDA		0.17745	0.09094	0.00188	0.00008	-0.00000	-0.00000		
		-0.00001	-0.00001	-0.00001	-0.00001	-0.00001	-0.00000		
		-0.00001	-0.00001						
AM	-2.	1.75000	2.00000	2.25000	2.50000	2.75000	3.00000		
		3.25000	3.50000	3.75000	4.00000	4.25000	4.50000		
		4.75000	5.00000						
PT3		0.79669	0.78834	0.77186	0.71933	0.60585	0.49986		
		0.40380	0.31441	0.26065	0.20948	0.16883	0.13644		
		0.11067	0.09613						
AOAC		0.59175	0.71267	0.85745	0.90743	0.90419	0.90169		
		0.88901	0.87697	0.86767	0.85849	0.85023	0.84196		
		0.83374	0.825						
CDA		0.23581	0.17838	0.02167	-0.00001	-0.00001	-0.00001		
		-0.00001	-0.00001	-0.00001	-0.00001	-0.00000	-0.00001		
		-0.00001	-0.00001						
AM	1.	1.75000	2.00000	2.25000	2.50000	2.75000	3.00000		
		3.25000	3.50000	3.75000	4.00000	4.25000	4.50000		
		4.75000	5.00000						
PT3		0.79126	0.78329	0.76084	0.73950	0.63519	0.52839		
		0.42926	0.34616	0.28137	0.22861	0.18623	0.15204		
		0.12494	0.10282						
AOAC		0.58771	0.71811	0.85449	0.99350	0.99055	0.98823		
		0.97610	0.96437	0.96433	0.96403	0.96470	0.96306		
		0.96816	0.96984						
CDA		0.33749	0.26826	0.15348	-0.00000	-0.00001	-0.00001		
		-0.00001	-0.00001	-0.00001	-0.00001	-0.00001	-0.00001		
		-0.00001	-0.00001						
AM	4.	1.75000	2.00000	2.25000	2.50000	2.75000	3.00000		
		3.25000	3.50000	3.75000	4.00000	4.25000	4.50000		
		4.75000	5.00000						
PT3		0.77922	0.76075	0.74149	0.70647	0.63716	0.54010		
		0.44420	0.36135	0.29828	0.24583	0.20315	0.16814		
		0.14012	0.11572						
AOAC		0.57878	0.68773	0.83276	0.99790	1.07334	1.06942		
		1.06157	1.05382	1.06746	1.08059	1.09545	1.10980		
		1.12841	1.13323						
CDA		0.44648	0.37529	0.29546	0.13006	-0.00001	-0.00001		
		-0.00001	-0.00001	-0.00001	-0.00001	-0.00000	-0.00001		
		-0.00001	-0.00001						

FIGURE 7-CONTINUED

AM	7.	1.75000	2.00000	2.25000	2.50000	2.75000	3.00000
		3.25000	3.50000	3.75000	4.00000	4.25000	4.50000
		4.75000	5.00000				
PT3		0.72996	0.77912	0.70291	0.67874	0.63848	0.54432
		0.46001	0.33075	0.31777	0.26427	0.22094	0.18482
		0.15433	0.12802				
AOAC		0.54219	0.65913	0.78943	0.95874	1.14122	1.16865
		1.16935	1.16960	1.19114	1.21188	1.23968	1.26676
		1.28770	1.27613				
CDA		0.53363	0.54330	0.43329	0.32677	0.09663	-0.00001
		-0.00001	-0.00001	-0.00001	-0.00001	-0.00001	-0.00000
		-0.00001	-0.00001				
AM	10.	1.75000	2.00000	2.25000	2.50000	2.75000	3.00000
		3.25000	3.50000	3.75000	4.00000	4.25000	4.50000
		4.75000	5.00000				
PT3		0.72605	0.66183	0.65913	0.63891	0.62006	0.56576
		0.46809	0.40013	0.33803	0.28341	0.23959	0.20237
		0.16851	0.14056				
AOAC		0.53928	0.59831	0.74027	0.90248	1.10869	1.28299
		1.29666	1.30921	1.33557	1.36070	1.40180	1.44198
		1.45636	1.46941				
CDA		0.64325	0.63868	0.63128	0.49140	0.33878	0.07338
		-0.00001	-0.00001	-0.00001	-0.00001	-0.00001	-0.00001
		-0.00001	-0.00001				
AM	13.	1.75000	2.00000	2.25000	2.50000	2.75000	3.00000
		3.25000	3.50000	3.75000	4.00000	4.25000	4.50000
		4.75000	5.00000				
PT3		0.72605	0.66112	0.61967	0.61102	0.59397	0.57360
		0.50737	0.41207	0.35763	0.30439	0.25987	0.22111
		0.18545	0.15558				
AOAC		0.53928	0.59766	0.69594	0.86309	1.06203	1.30121
		1.45886	1.47615	1.51214	1.54563	1.59532	1.64297
		1.66406	1.68281				
CDA		0.73759	0.69822	0.73777	0.69817	0.52852	0.34373
		0.10079	-0.00001	-0.00001	-0.00001	-0.00001	-0.00001
		-0.00002	-0.00001				
AM	16.	1.75000	2.00000	2.25000	2.50000	2.75000	3.00000
		3.25000	3.50000	3.75000	4.00000	4.25000	4.50000
		4.75000	5.00000				
PT3		0.72624	0.66946	0.60045	0.58044	0.56420	0.54836
		0.52045	0.45733	0.37342	0.31860	0.27771	0.23970
		0.20497	0.17487				
AOAC		0.53942	0.50520	0.67436	0.81989	1.00681	1.24395
		1.49696	1.36286	1.71016	1.75311	1.81935	1.88208
		1.92896	1.97197				
CDA		0.82173	0.80117	0.80256	0.84743	0.76636	0.58116
		0.39460	0.14856	0.03070	-0.00001	-0.00001	-0.00002
		-0.00001	-0.00001				

FIGURE 8
 INLET PERFORMANCE CHARACTERISTICS - RAMJET-BOTTOM CENTERLINE-M=1.75
 INLET DESIGN MACH NO.=1.75, BOTTOM CENTERLINE, SINGLE RAMP)RAMJET*

AV	3 8 MACH	PT3	AOAC	CDA	EXT.COMPR.	13.00,	0.01,	0.01	DEG.RAMPS,	1.75
AV	-5.	1.75000	2.00000	2.25000	2.50000	2.75000	3.00000			
		3.25000	3.50000	3.75000	4.00000	4.25000	4.50000			
		4.75000	5.00000							
PT3		0.75599	0.67632	0.57249	0.47326	0.37838	0.29977			
		0.23209	0.17965	0.14090	0.11094	0.08564	0.06651			
		0.05348	0.04321							
AOAC		0.92898	0.94636	0.93722	0.92960	0.90332	0.87877			
		0.83857	0.80211	0.77822	0.75644	0.71806	0.68332			
		0.67124	0.65937							
CDA		-0.00000	-0.00000	-0.00000	-0.00000	-0.00000	-0.00001			
		-0.00001	-0.00001	-0.00001	-0.00000	-0.00001	-0.00002			
		-0.00002	-0.00002							
AM	-2.	1.75000	2.00000	2.25000	2.50000	2.75000	3.00000			
		3.25000	3.50000	3.75000	4.00000	4.25000	4.50000			
		4.75000	5.00000							
PT3		0.76528	0.68582	0.58475	0.48672	0.39269	0.31379			
		0.24608	0.19278	0.15241	0.12086	0.09526	0.07544			
		0.06100	0.04946							
AOAC		0.95329	0.96757	0.96448	0.96264	0.94371	0.92569			
		0.89479	0.86616	0.84680	0.82876	0.80363	0.77988			
		0.77054	0.75976							
CDA		-0.00001	-0.00000	-0.00000	-0.00000	-0.00001	-0.00001			
		-0.00001	-0.00000	-0.00001	-0.00001	-0.00002	-0.00001			
		-0.00001	-0.00002							
AM	1.	1.75000	2.00000	2.25000	2.50000	2.75000	3.00000			
		3.25000	3.50000	3.75000	4.00000	4.25000	4.50000			
		4.75000	5.00000							
PT3		0.77164	0.69485	0.59713	0.50068	0.40804	0.32921			
		0.26126	0.20696	0.16497	0.13181	0.10614	0.08575			
		0.07001	0.05721							
AOAC		0.97737	0.99013	0.99348	0.99803	0.98805	0.97823			
		0.95679	0.93634	0.92274	0.90955	0.90157	0.89291			
		0.89096	0.88537							
CDA		-0.00000	-0.00000	-0.00000	-0.00000	-0.00000	-0.00001			
		-0.00001	-0.00001	-0.00001	-0.00001	-0.00003	-0.00001			
		-0.00002	-0.00001							
AM	4.	1.75000	2.00000	2.25000	2.50000	2.75000	3.00000			
		3.25000	3.50000	3.75000	4.00000	4.25000	4.50000			
		4.75000	5.00000							
PT3		0.76835	0.70254	0.60945	0.51533	0.42502	0.34693			
		0.27804	0.21226	0.17871	0.14390	0.11846	0.09770			
		0.08115	0.06739							
AOAC		0.99018	1.01489	1.02523	1.03708	1.03881	1.04016			
		1.02692	1.01362	1.00732	1.00036	1.01435	1.02602			
		1.04202	1.05240							
CDA		0.00524	0.0	-0.00000	-0.00000	-0.00000	-0.00000			
		-0.00000	-0.00001	-0.00001	-0.00000	-0.00001	-0.00002			
		-0.00003	-0.00003							

FIGURE 8-CONTINUED

AM	7.	1.75000	2.00000	2.25000	2.50000	2.75000	3.00000
		3.25000	3.50000	3.75000	4.00000	4.25000	4.50000
		4.75000	5.00000				
PT3		0.75092	0.71411	0.63110	0.54243	0.45099	0.37048
		0.30049	0.24286	0.19739	0.16050	0.13386	0.11173
		0.09402	0.07899				
AOAC		0.98789	1.05902	1.08410	1.11168	1.11909	1.12512
		1.12307	1.11972	1.12432	1.12697	1.15785	1.18529
		1.21964	1.24649				
CDA		0.03289	-0.00000	-0.00000	-0.00000	-0.00000	-0.00001
		-0.00001	-0.00001	-0.00001	-0.00001	-0.00001	-0.00001
		-0.00002	-0.00001				
AM	10.	1.75000	2.00000	2.25000	2.50000	2.75000	3.00000
		3.25000	3.50000	3.75000	4.00000	4.25000	4.50000
		4.75000	5.00000				
PT3		0.74102	0.72069	0.65488	0.57518	0.48179	0.39760
		0.32687	0.26746	0.22005	0.18093	0.15224	0.12808
		0.10895	0.09244				
AOAC		0.97787	1.11318	1.15862	1.20870	1.21930	1.22685
		1.23957	1.24976	1.26957	1.28611	1.33269	1.37460
		1.43008	1.47608				
CDA		0.08749	-0.00000	-0.00000	-0.00000	-0.00000	-0.00001
		-0.00001	-0.00001	-0.00001	-0.00001	-0.00001	-0.00001
		-0.00001	-0.00001				
AM	13.	1.75000	2.00000	2.25000	2.50000	2.75000	3.00000
		3.25000	3.50000	3.75000	4.00000	4.25000	4.50000
		4.75000	5.00000				
PT3		0.74964	0.71268	0.67719	0.60203	0.51415	0.43189
		0.35807	0.27506	0.24488	0.20292	0.17150	0.14477
		0.12369	0.10527				
AOAC		0.98925	1.14279	1.24064	1.29731	1.33004	1.35916
		1.38153	1.39996	1.43299	1.46154	1.52071	1.57324
		1.64367	1.71159				
CDA		0.15019	0.03419	-0.00000	-0.00000	-0.00000	-0.00001
		-0.00000	-0.00001	-0.00001	-0.00001	-0.00001	-0.00000
		-0.00001	-0.00001				
AM	16.	1.75000	2.00000	2.25000	2.50000	2.75000	3.00000
		3.25000	3.50000	3.75000	4.00000	4.25000	4.50000
		4.75000	5.00000				
PT3		0.75481	0.71455	0.69173	0.62758	0.54710	0.46817
		0.39160	0.32504	0.27207	0.22716	0.19270	0.16309
		0.13990	0.11941				
AOAC		0.99607	1.14765	1.32216	1.39279	1.45156	1.50702
		1.54084	1.56903	1.61780	1.66073	1.73354	1.79718
		1.88487	1.95648				
CDA		0.19824	0.08948	-0.00000	-0.00000	-0.00000	-0.00001
		-0.00001	-0.00001	-0.00001	-0.00001	-0.00001	-0.00002
		-0.00001	-0.00001				

FIGURE 9
 INLET PERFORMANCE CHARACTERISTICS - RAMJET-BOTTOM CENTERLINE-M=2.00
 INLET DESIGN MACH NO.=2.00, BOTTOM CENTERLINE, DOUBLE RAMP RAMJET*

AV	3 8 MACH	PT3	AOAC	CDA	EXT.COMPR. 10.40, 11.10, 0.01 DEG.RAMPS, 2.00		
AV	-5.00000	-2.00000	1.00000	4.00000	7.00000	10.00000	
	13.00000	16.00000					
1414141414141414							
AM	-5.	1.75000	2.00000	2.25000	2.50000	2.75000	3.00000
		3.25000	3.50000	3.75000	4.00000	4.25000	4.50000
		4.75000	5.00000				
PT3		0.78768	0.76356	0.66349	0.55610	0.44870	0.35764
		0.27814	0.21595	0.16976	0.13387	0.10345	0.08040
		0.06468	0.05228				
AOAC		0.85627	0.94865	0.93949	0.93185	0.90523	0.88037
		0.83984	0.80309	0.77916	0.75736	0.71871	0.68374
		0.67165	0.65977				
CDA		0.06533	-0.00000	-0.00000	-0.00000	-0.00000	-0.00000
		-0.00001	-0.00001	-0.00001	-0.00000	-0.00001	-0.00001
		-0.00001	-0.00001				
AM	-2.	1.75000	2.00000	2.25000	2.50000	2.75000	3.00000
		3.25000	3.50000	3.75000	4.00000	4.25000	4.50000
		4.75000	5.00000				
PT3		0.79030	0.77058	0.67637	0.57133	0.46539	0.37423
		0.29482	0.23170	0.18361	0.14586	0.11511	0.09123
		0.07380	0.05987				
AOAC		0.85911	0.97131	0.96820	0.96636	0.94699	0.92854
		0.89720	0.86816	0.84875	0.83066	0.80538	0.78148
		0.77199	0.76105				
CDA		0.09387	-0.00000	-0.00000	-0.00000	-0.00000	-0.00001
		-0.00001	-0.00000	-0.00000	-0.00000	-0.00002	-0.00002
		-0.00002	-0.00002				
AM	1.	1.75000	2.00000	2.25000	2.50000	2.75000	3.00000
		3.25000	3.50000	3.75000	4.00000	4.25000	4.50000
		4.75000	5.00000				
PT3		0.79049	0.77523	0.68920	0.58717	0.48341	0.39263
		0.31307	0.24883	0.19885	0.15917	0.12835	0.10379
		0.08477	0.06929				
AOAC		0.85932	0.99688	0.99996	1.00425	0.99377	0.98346
		0.96148	0.94051	0.92682	0.91354	0.90551	0.89678
		0.89456	0.88000				
CDA		0.12497	-0.00000	-0.00000	-0.00000	-0.00000	-0.00001
		-0.00001	-0.00001	-0.00001	-0.00001	-0.00001	-0.00000
		-0.00001	-0.00001				
AM	4.	1.75000	2.00000	2.25000	2.50000	2.75000	3.00000
		3.25000	3.50000	3.75000	4.00000	4.25000	4.50000
		4.75000	5.00000				
PT3		0.78534	0.77127	0.70129	0.60382	0.50355	0.41401
		0.33352	0.26758	0.21572	0.17404	0.14345	0.11843
		0.09842	0.08176				
AOAC		0.85372	1.01010	1.03712	1.04791	1.04920	1.05011
		1.03630	1.02243	1.01597	1.00883	1.02282	1.03446
		1.05029	1.06044				
CDA		0.16058	0.01646	-0.00000	-0.00000	-0.00000	-0.00000
		-0.00000	-0.00001	-0.00001	-0.00000	-0.00000	-0.00002
		-0.00001	-0.00002				

FIGURE 9-CONTINUED

AM	7.	1.75000	2.00000	2.25000	2.50000	2.75000	3.00000
		3.25000	3.50000	3.75000	4.00000	4.25000	4.50000
		4.75000	5.00000				
PT3		0.77362	0.71860	0.71902	0.63308	0.53359	0.44205
		0.36058	0.29257	0.23846	0.19429	0.16224	0.13555
		0.11413	0.09592				
AOAC		0.84098	1.00368	1.10456	1.12987	1.13649	1.14169
		1.13869	1.13437	1.13861	1.14087	1.17170	1.19903
		1.23328	1.25994				
CDA		0.20571	0.09853	-0.00000	-0.00000	-0.00000	-0.00001
		-0.00001	-0.00001	-0.00001	-0.00001	-0.00001	-0.00001
		-0.00001	-0.00003				
AM	10.	1.75000	2.00000	2.25000	2.50000	2.75000	3.00000
		3.25000	3.50000	3.75000	4.00000	4.25000	4.50000
		4.75000	5.00000				
PT3		0.74971	0.75053	0.72517	0.66524	0.56793	0.47373
		0.39200	0.31217	0.26586	0.21908	0.18457	0.15543
		0.13229	0.11229				
AOAC		0.81499	0.99301	1.18995	1.23650	1.24568	1.25171
		1.26297	1.27161	1.29089	1.30680	1.35318	1.39477
		1.45026	1.47606				
CDA		0.24547	0.19212	-0.00000	-0.00000	-0.00000	-0.00000
		-0.00001	-0.00001	-0.00001	-0.00001	-0.00001	-0.00001
		-0.00001	-0.00001				
AM	13.	1.75000	2.00000	2.25000	2.50000	2.75000	3.00000
		3.25000	3.50000	3.75000	4.00000	4.25000	4.50000
		4.75000	5.00000				
PT3		0.74964	0.71245	0.72900	0.68612	0.60207	0.51275
		0.42863	0.35514	0.29579	0.24575	0.20801	0.17578
		0.15027	0.11795				
AOAC		0.81492	0.98231	1.19826	1.33467	1.36615	1.39380
		1.41466	1.43139	1.46396	1.49188	1.55098	1.60320
		1.67352	1.73097				
CDA		0.30009	0.26039	0.13072	-0.00000	0.00000	-0.00000
		-0.00000	-0.00000	-0.00001	-0.00001	-0.00001	-0.00001
		-0.00001	-0.00001				
AM	16.	1.75000	2.00000	2.25000	2.50000	2.75000	3.00000
		3.25000	3.50000	3.75000	4.00000	4.25000	4.50000
		4.75000	5.00000				
PT3		0.75481	0.72845	0.72578	0.69695	0.63343	0.55238
		0.46712	0.39046	0.32823	0.27492	0.23363	0.19800
		0.16995	0.14513				
AOAC		0.82053	0.91379	1.19297	1.44032	1.49847	1.55296
		1.58537	1.61187	1.66034	1.70270	1.77557	1.83890
		1.92647	1.99742				
CDA		0.35675	0.30794	0.23833	0.00768	-0.00000	-0.00000
		-0.00000	-0.00001	-0.00000	-0.00001	-0.00001	-0.00001
		-0.00001	-0.00001				

FIGURE 10
 INLET PERFORMANCE CHARACTERISTICS - RAMJET-BOTTOM CENTERLINE-M=2.25
 INLET DESIGN MACH NO.=2.25, BOTTOM CENTERLINE, TRIPLE RAMP RAMJET*

AV	3 8 MACH	PT3	AOAC	CDA	EXT.COMPR.	9.00,	9.80,	10.30	DEG.RAMPS,	2.25
AV	-5.00000	-2.00000	1.00000	4.00000	7.00000	10.00000				
	13.00000	16.00000								
1414141414141414										
AM	-5.	1.75000	2.00000	2.25000	2.50000	2.75000	3.00000			
		3.25000	3.50000	3.75000	4.00000	4.25000	4.50000			
		4.75000	5.00000							
PT3		0.79930	0.78830	0.75651	0.65050	0.53162	0.42670			
		0.33326	0.25932	0.20403	0.16091	0.12426	0.09645			
		0.07747	0.06250							
AOAC		0.70466	0.84584	0.94128	0.93363	0.90675	0.88164			
		0.84085	0.80386	0.77991	0.75808	0.71923	0.68407			
		0.67198	0.66009							
CDA		0.18554	0.11454	-0.00000	-0.00000	-0.00000	-0.00000			
		-0.00001	-0.00001	-0.00001	-0.00000	-0.00000	-0.00001			
		-0.00002	-0.00001							
AM	-2.	1.75000	2.00000	2.25000	2.50000	2.75000	3.00000			
		3.25000	3.50000	3.75000	4.00000	4.25000	4.50000			
		4.75000	5.00000							
PT3		0.79791	0.78860	0.76600	0.66654	0.55058	0.44611			
		0.35305	0.27815	0.22069	0.17536	0.13834	0.10954			
		0.08851	0.07169							
AOAC		0.70343	0.84615	0.97115	0.96930	0.94958	0.93080			
		0.89911	0.86974	0.85029	0.83218	0.80677	0.78276			
		0.77314	0.76207							
CDA		0.20239	0.13940	-0.00000	-0.00000	-0.00000	-0.00001			
		-0.00001	-0.00001	-0.00001	-0.00001	-0.00001	-0.00001			
		-0.00001	-0.00003							
AM	1.	1.75000	2.00000	2.25000	2.50000	2.75000	3.00000			
		3.25000	3.50000	3.75000	4.00000	4.25000	4.50000			
		4.75000	5.00000							
PT3		0.79303	0.78722	0.77199	0.68269	0.57091	0.46759			
		0.37470	0.29866	0.23902	0.19142	0.15433	0.12472			
		0.10178	0.08310							
AOAC		0.69912	0.84467	1.00510	1.00918	0.99830	0.98761			
		0.96519	0.94381	0.93006	0.91671	0.90863	0.89985			
		0.89741	0.89131							
CDA		0.22782	0.16834	-0.00000	-0.00000	-0.00000	-0.00001			
		-0.00001	-0.00001	-0.00001	-0.00001	-0.00001	-0.00001			
		-0.00000	-0.00000							
AM	4.	1.75000	2.00000	2.25000	2.50000	2.75000	3.00000			
		3.25000	3.50000	3.75000	4.00000	4.25000	4.50000			
		4.75000	5.00000							
PT3		0.78815	0.78199	0.76682	0.69828	0.59320	0.49240			
		0.39894	0.32113	0.25933	0.20937	0.17258	0.14242			
		0.11829	0.09818							
AOAC		0.69482	0.83906	1.01924	1.05650	1.05744	1.05801			
		1.04374	1.02943	1.02282	1.01554	1.02953	1.04116			
		1.05685	1.06682							
CDA		0.27818	0.20663	0.03149	-0.00000	-0.00000	-0.00001			
		-0.00001	-0.00001	-0.00001	-0.00001	-0.00001	-0.00001			
		-0.00001	-0.00001							

FIGURE 10-CONTINUED

AM	7.	1.75000	2.00000	2.25000	2.50000	2.75000	3.00000
		3.25000	3.50000	3.75000	4.00000	4.25000	4.50000
		4.75000	5.00000				
PT3		0.78022	0.77175	0.75977	0.72085	0.62487	0.52422
		0.43061	0.35080	0.28653	0.23371	0.19523	0.16310
		0.13727	0.11532				
AOAC		0.68783	0.82807	1.01277	1.14430	1.15029	1.15483
		1.15108	1.14599	1.14994	1.15190	1.18269	1.20993
		1.24411	1.27060				
CDA		0.34395	0.26302	0.15019	-0.00000	-0.00000	-0.00000
		-0.00001	-0.00001	-0.00001	-0.00001	-0.00001	-0.00001
		-0.00001	-0.00001				
AM	10.	1.75000	2.00000	2.25000	2.50000	2.75000	3.00000
		3.25000	3.50000	3.75000	4.00000	4.25000	4.50000
		4.75000	5.00000				
PT3		0.76355	0.75639	0.75231	0.73562	0.65725	0.55882
		0.46670	0.38559	0.31909	0.26337	0.22204	0.18703
		0.15918	0.13509				
AOAC		0.67313	0.81139	1.00283	1.23286	1.26659	1.27142
		1.28153	1.28894	1.30778	1.32320	1.36944	1.41077
		1.46625	1.51190				
CDA		0.39783	0.35726	0.25965	0.04930	-0.00000	-0.00001
		-0.00001	-0.00001	-0.00001	-0.00001	-0.00001	-0.00001
		-0.00002	-0.00001				
AM	13.	1.75000	2.00000	2.25000	2.50000	2.75000	3.00000
		3.25000	3.50000	3.75000	4.00000	4.25000	4.50000
		4.75000	5.00000				
PT3		0.74964	0.71171	0.74316	0.73314	0.68087	0.59911
		0.50764	0.42373	0.35429	0.29505	0.25003	0.21143
		0.18079	0.15395				
AOAC		0.66087	0.80656	0.99063	1.22913	1.39478	1.42127
		1.44092	1.45632	1.48851	1.51593	1.57498	1.62696
		1.69718	1.75426				
CDA		0.44040	0.45000	0.34531	0.21196	-0.00000	-0.00000
		-0.00001	-0.00001	-0.00001	-0.00001	-0.00001	-0.00001
		-0.00001	-0.00002				
AM	16.	1.75000	2.00000	2.25000	2.50000	2.75000	3.00000
		3.25000	3.50000	3.75000	4.00000	4.25000	4.50000
		4.75000	5.00000				
PT3		0.75481	0.74254	0.73305	0.72772	0.70775	0.63441
		0.54854	0.46356	0.39182	0.32932	0.28036	0.23789
		0.20431	0.17455				
AOAC		0.66543	0.79673	0.97715	1.22004	1.50200	1.58938
		1.62068	1.64585	1.69407	1.73598	1.80890	1.87199
		1.95946	2.02988				
CDA		0.50239	0.50996	0.45763	0.33582	0.10937	-0.00000
		-0.00001	-0.00001	-0.00001	-0.00001	-0.00001	-0.00002
		-0.00001	-0.00001				

FIGURE 11
 INLET PERFORMANCE CHARACTERISTICS - RAMJET-BOTTOM CENTERLINE-M=2.50
 INLET DESIGN MACH NO.=2.50, BOTTOM CENTERLINE, TRIPLE RAMP RAMJET*

AV	3 8 MACH	PT3	AOAC	CDA	EXT.COI.PR.	10.00	11.10	12.10	DEG.RAMPS, 2.50
AV	-5.00000	-2.00000	1.00000	4.00000	7.00000	10.00000			
	13.00000	16.00000							
1414141414141414									
AM	-5.	1.75000	2.00000	2.25000	2.50000	2.75000	3.00000		
		3.25000	3.50000	3.75000	4.00000	4.25000	4.50000		
		4.75000	5.00000						
PT3		0.78937	0.78579	0.76636	0.72009	0.59937	0.48494		
		0.38033	0.29649	0.23335	0.18392	0.14185	0.10990		
		0.08810	0.07091						
AOAC		0.58257	0.70582	0.84799	0.93443	0.90743	0.88220		
		0.84130	0.80420	0.78024	0.75841	0.71946	0.68421		
		0.67212	0.66023						
CDA		0.27900	0.24483	0.09636	-0.00000	-0.00000	-0.00001		
		-0.00001	-0.00001	-0.00001	-0.00000	-0.00000	-0.00000		
		-0.00001	-0.00001						
AM	-2.	1.75000	2.00000	2.25000	2.50000	2.75000	3.00000		
		3.25000	3.50000	3.75000	4.00000	4.25000	4.50000		
		4.75000	5.00000						
PT3		0.79028	0.70503	0.76276	0.73345	0.61911	0.50622		
		0.40252	0.31784	0.25233	0.20045	0.15797	0.12490		
		0.10076	0.08147						
AOAC		0.58323	0.70515	0.85117	0.97062	0.95074	0.93181		
		0.89996	0.87044	0.85098	0.83285	0.80739	0.78333		
		0.77365	0.76253						
CDA		0.31180	0.26552	0.13620	-0.00000	-0.00000	-0.00001		
		-0.00001	-0.00001	-0.00001	-0.00001	-0.00001	-0.00000		
		-0.00001	-0.00001						
AM	1.	1.75000	2.00000	2.25000	2.50000	2.75000	3.00000		
		3.25000	3.50000	3.75000	4.00000	4.25000	4.50000		
		4.75000	5.00000						
PT3		0.79087	0.78220	0.76352	0.74407	0.63955	0.52940		
		0.42657	0.34093	0.27311	0.21872	0.17623	0.14226		
		0.11596	0.09455						
AOAC		0.58367	0.70261	0.85202	1.01138	1.00033	0.98946		
		0.96685	0.94529	0.93150	0.91813	0.91002	0.90122		
		0.89868	0.89248						
CDA		0.34726	0.29118	0.18238	-0.00001	0.00000	-0.00001		
		-0.00001	-0.00001	-0.00001	-0.00001	-0.00001	-0.00001		
		-0.00000	-0.00000						
AM	4.	1.75000	2.00000	2.25000	2.50000	2.75000	3.00000		
		3.25000	3.50000	3.75000	4.00000	4.25000	4.50000		
		4.75000	5.00000						
PT3		0.78639	0.77464	0.76085	0.74496	0.66015	0.55535		
		0.45298	0.36587	0.29589	0.23897	0.19692	0.16239		
		0.13477	0.11175						
AOAC		0.58037	0.69581	0.84903	1.02941	1.06112	1.06152		
		1.04705	1.00234	1.02588	1.01853	1.03253	1.04414		
		1.05977	1.00966						
CDA		0.39369	0.32636	0.24033	0.03603	-0.00000	-0.00000		
		-0.00000	-0.00001	-0.00001	-0.00001	-0.00001	-0.00001		
		-0.00001	-0.00001						

FIGURE 11-CONTINUED

AM	7.	1.75000	2.00000	2.25000	2.50000	2.75000	3.00000
		3.25000	3.50000	3.75000	4.00000	4.25000	4.50000
		4.75000	5.00000				
PT3		0.77581	0.75932	0.75490	0.73337	0.68505	0.58721
		0.48689	0.39857	0.32627	0.26638	0.22255	0.18588
		0.15638	0.13130				
AOAC		0.57255	0.68205	0.84240	1.02927	1.15644	1.16069
		1.15660	1.15116	1.15499	1.15682	1.18759	1.21478
		1.24893	1.27535				
CDA		0.45635	0.40696	0.32757	0.16441	-0.00000	-0.00000
		-0.00001	-0.00001	-0.00001	-0.00001	-0.00001	-0.00001
		-0.00001	-0.00001				
AM	10.	1.75000	2.00000	2.25000	2.50000	2.75000	3.00000
		3.25000	3.50000	3.75000	4.00000	4.25000	4.50000
		4.75000	5.00000				
PT3		0.75445	0.75250	0.74308	0.73206	0.69924	0.61859
		0.52428	0.43631	0.36229	0.29959	0.25278	0.21299
		0.18128	0.15382				
AOAC		0.55679	0.67592	0.82921	1.02744	1.24193	1.28021
		1.28980	1.29666	1.31532	1.33051	1.37668	1.41790
		1.47338	1.51897				
CDA		0.50777	0.51435	0.42372	0.31970	0.05049	-0.00001
		-0.00001	-0.00000	-0.00001	-0.00001	-0.00001	-0.00001
		-0.00002	-0.00002				
AM	13.	1.75000	2.00000	2.25000	2.50000	2.75000	3.00000
		3.25000	3.50000	3.75000	4.00000	4.25000	4.50000
		4.75000	5.00000				
PT3		0.74964	0.74543	0.73049	0.72609	0.70257	0.64707
		0.56426	0.47646	0.40047	0.33453	0.28391	0.24031
		0.20559	0.17512				
AOAC		0.55325	0.66938	0.81515	1.01906	1.24819	1.43352
		1.45263	1.46743	1.49945	1.52666	1.58568	1.63755
		1.70773	1.70464				
CDA		0.56996	0.50857	0.54053	0.43916	0.25246	-0.00000
		-0.00001	-0.00001	-0.00001	-0.00001	-0.00001	-0.00001
		-0.00001	-0.00002				
AM	16.	1.75000	2.00000	2.25000	2.50000	2.75000	3.00000
		3.25000	3.50000	3.75000	4.00000	4.25000	4.50000
		4.75000	5.00000				
PT3		0.75481	0.73314	0.72817	0.71704	0.70209	0.67126
		0.59805	0.51620	0.44001	0.37166	0.31721	0.26963
		0.23183	0.19822				
AOAC		0.55706	0.65834	0.81257	1.00636	1.24733	1.51250
		1.63642	1.66099	1.70910	1.75082	1.82376	1.88674
		1.97417	2.04435				
CDA		0.64007	0.65123	0.65853	0.54975	0.43084	0.16239
		-0.00001	-0.00001	-0.00000	-0.00001	-0.00001	-0.00001
		-0.00001	-0.00001				

FIGURE 12
 INLET PERFORMANCE CHARACTERISTICS - COMBINED CYCLE-BOTTOM CENTERLINE-M=2.50
 INLET DESIGN MACH NO.=2.50, DOUPEL RAMP, BOTTOM CENTERLINE, COMBINED CYCLE

AV	3 8 MACH	PT3	AOAC	CDA	EXT.COMPR.	13.40	15.60	0.01	DEG.RAMPS	2.50
AV	-5.00000	-2.00000	1.00000	4.00000	7.00000	10.00000				
	13.00000	16.00000								
1515151515151515										
AM	-5.	0.75000	1.00000	1.25000	1.50000	1.75000	2.00000			
		2.25000	2.50000	2.75000	3.00000	3.25000	3.50000			
		4.00000	4.50000	5.00000						
PT3		0.82000	0.81938	0.80907	0.79062	0.78363	0.75767			
		0.73452	0.67325	0.55628	0.44924	0.35238	0.27507			
		0.17138	0.10311	0.06700						
AOAC		0.50297	0.47306	0.48895	0.53687	0.62728	0.73817			
		0.87018	0.93313	0.90633	0.88128	0.84057	0.80364			
		0.75788	0.68398	0.66000						
CDA		-0.06545	0.18315	0.28434	0.27849	0.28225	0.21310			
		0.05134	-0.00000	-0.00000	-0.00000	-0.00001	-0.00000			
		-0.00000	-0.00000	-0.00000						
AM	-2.	0.75000	1.00000	1.25000	1.50000	1.75000	2.00000			
		2.25000	2.50000	2.75000	3.00000	3.25000	3.50000			
		4.00000	4.50000	5.00000						
PT3		0.82000	0.81965	0.81138	0.78598	0.78410	0.75976			
		0.73429	0.68716	0.57473	0.46880	0.37272	0.29463			
		0.18654	0.11692	0.07922						
AOAC		0.50297	0.47322	0.49035	0.53372	0.62766	0.74021			
		0.87655	0.96848	0.94886	0.93017	0.89857	0.86929			
		0.83175	0.78240	0.78656						
CDA		-0.06048	0.13770	0.30202	0.30048	0.30366	0.24060			
		0.07465	-0.00000	-0.00000	-0.00000	-0.00000	-0.00000			
		-0.00001	-0.00000	-0.00001						
AM	1.	0.75000	1.00000	1.25000	1.50000	1.75000	2.00000			
		2.25000	2.50000	2.75000	3.00000	3.25000	3.50000			
		4.00000	4.50000	5.00000						
PT3		0.81971	0.81927	0.81218	0.78676	0.78108	0.75988			
		0.73019	0.69962	0.59379	0.49000	0.39463	0.31568			
		0.20324	0.13285	0.09385						
AOAC		0.50279	0.47300	0.49083	0.53425	0.62524	0.74033			
		0.87901	1.00780	0.99704	0.98645	0.96415	0.94289			
		0.91583	0.89899	0.94171						
CDA		-0.05178	0.19954	0.32580	0.33351	0.32808	0.27436			
		0.11091	-0.00000	0.00000	-0.00001	-0.00001	-0.00001			
		-0.00001	-0.00000	-0.00001						
AM	4.	0.75000	1.00000	1.25000	1.50000	1.75000	2.00000			
		2.25000	2.50000	2.75000	3.00000	3.25000	3.50000			
		4.00000	4.50000	5.00000						
PT3		0.81885	0.81774	0.81047	0.78487	0.77015	0.75540			
		0.71909	0.70244	0.61314	0.51353	0.41845	0.33819			
		0.22162	0.15125	0.11112						
AOAC		0.50227	0.47212	0.48979	0.53297	0.61649	0.73596			
		0.87036	1.00182	1.05514	1.05580	1.04166	1.02747			
		1.01366	1.03928	1.13218						
CDA		-0.03390	0.22789	0.36370	0.37550	0.35748	0.32018			
		0.17715	0.02030	-0.00000	0.0	-0.00000	-0.00001			
		-0.00000	-0.00001	-0.00001						

FIGURE 12-CONTINUED

AM	7.	0.75000	1.00000	1.25000	1.50000	1.75000	2.00000
		2.25000	2.50000	2.75000	3.00000	3.25000	3.50000
		4.00000	4.50000	5.00000			
PT3		0.81348	0.81227	0.80591	0.78216	0.74531	0.74574
		0.72035	0.69861	0.63861	0.54282	0.44920	0.36780
		0.24651	0.17267	0.12956			
AOAC		0.49897	0.46896	0.48704	0.53113	0.59661	0.72655
		0.87188	1.04914	1.14643	1.15116	1.14761	1.14274
		1.14882	1.20688	1.34172			
CDA		-0.01522	0.26274	0.41173	0.43434	0.41100	0.38981
		0.28942	0.09259	-0.00000	-0.00000	-0.00001	-0.00001
		-0.00001	-0.00001	-0.00002			
AM	10.	0.75000	1.00000	1.25000	1.50000	1.75000	2.00000
		2.25000	2.50000	2.75000	3.00000	3.25000	3.50000
		4.00000	4.50000	5.00000			
PT3		0.80585	0.80480	0.79982	0.77880	0.74102	0.72725
		0.71597	0.68705	0.65666	0.57278	0.48342	0.40208
		0.27666	0.17734	0.14980			
AOAC		0.49429	0.46465	0.48336	0.52885	0.59317	0.70853
		0.86658	1.04589	1.25485	1.26591	1.27634	1.28410
		1.31861	1.40630	1.57983			
CDA		0.00487	0.30173	0.45940	0.49977	0.48092	0.46015
		0.40865	0.24980	0.00680	-0.00000	-0.00001	-0.00000
		-0.00001	-0.00001	-0.00001			
AM	13.	0.75000	1.00000	1.25000	1.50000	1.75000	2.00000
		2.25000	2.50000	2.75000	3.00000	3.25000	3.50000
		4.00000	4.50000	5.00000			
PT3		0.80093	0.79966	0.79568	0.78061	0.74964	0.70500
		0.70987	0.68919	0.65938	0.60433	0.52083	0.43874
		0.30834	0.22210	0.17015			
AOAC		0.49128	0.46168	0.48086	0.53007	0.60007	0.68686
		0.85920	1.04915	1.26271	1.41359	1.43358	1.44935
		1.50921	1.62032	1.83272			
CDA		0.03020	0.33051	0.49791	0.56051	0.56050	0.53606
		0.50593	0.35734	0.15622	-0.00000	-0.00000	-0.00001
		-0.00001	-0.00001	-0.00001			
AM	16.	0.75000	1.00000	1.25000	1.50000	1.75000	2.00000
		2.25000	2.50000	2.75000	3.00000	3.25000	3.50000
		4.00000	4.50000	5.00000			
PT3		0.79583	0.79437	0.79124	0.77998	0.75481	0.71455
		0.69892	0.66735	0.65563	0.62953	0.55499	0.47563
		0.34207	0.24865	0.19202			
AOAC		0.48815	0.45863	0.47817	0.52964	0.60421	0.69616
		0.84595	1.04634	1.26338	1.53855	1.61081	1.63635
		1.72668	1.86274	2.11830			
CDA		0.05212	0.35597	0.52907	0.60868	0.62689	0.59852
		0.58497	0.52744	0.35791	0.06652	-0.00001	-0.00001
		-0.00001	-0.00001	-0.00001			

FIGURE 13
 INLET PERFORMANCE CHARACTERISTICS - TURBOJET-BOTTOM CENTERLINE-NORMAL SHOCK
 INLET DESIGN MACH NO.=1.5)NORMAL SHOCK*, TURBOJET, BOTTOM CENTERLINE

AV	3 8 MACH	PT3	AOAC	CDA	EXT.COMPR.	0.20,	0.01,	0.01	DEG.RAMPS,	1.50
AV	-5.00000	-2.00000	1.00000	4.00000	7.00000	10.00000				
	13.00000	16.00000								
1212121212121212										
AM	-5.	0.50000	0.60000	0.70000	0.80000	0.90000	1.00000			
		1.10000	1.20000	1.30000	1.40000	1.50000	1.60000			
PT3		0.95000	0.95000	0.95000	0.95000	0.94996	0.94811			
		0.93911	0.92344	0.90110	0.87442	0.83969	0.80596			
AOAC		1.33710	1.18577	1.09213	1.03610	1.00676	0.98596			
		0.96467	0.94888	0.93668	0.93020	0.92066	0.92133			
CDA		0.15680	0.04745	0.00858	-0.00195	-0.00068	-0.00001			
		-0.00001	-0.00001	-0.00001	-0.00001	-0.00001	-0.00001			
AM	-2.	0.50000	0.60000	0.70000	0.80000	0.90000	1.00000			
		1.10000	1.20000	1.30000	1.40000	1.50000	1.60000			
PT3		0.95000	0.95000	0.95000	0.95000	0.94999	0.94947			
		0.94340	0.93018	0.91003	0.88512	0.85399	0.82025			
AOAC		1.33710	1.18577	1.09213	1.03610	1.00679	0.99316			
		0.97691	0.96382	0.95387	0.94923	0.94485	0.94532			
CDA		0.16788	0.05200	0.00993	-0.00186	-0.00115	-0.00017			
		-0.00001	-0.00001	-0.00001	-0.00001	-0.00000	-0.00001			
AM	1.	0.50000	0.60000	0.70000	0.80000	0.90000	1.00000			
		1.10000	1.20000	1.30000	1.40000	1.50000	1.60000			
PT3		0.94980	0.94976	0.94971	0.94962	0.94952	0.94916			
		0.94662	0.93594	0.91804	0.89472	0.86545	0.83215			
AOAC		1.33682	1.18543	1.09180	1.03569	1.00629	0.99706			
		0.99011	0.97920	0.97127	0.96797	0.96579	0.96650			
CDA		0.17203	0.05621	0.00871	-0.00327	-0.00226	0.00075			
		-0.00001	-0.00001	-0.00001	-0.00001	-0.00001	-0.00001			
AM	4.	0.50000	0.60000	0.70000	0.80000	0.90000	1.00000			
		1.10000	1.20000	1.30000	1.40000	1.50000	1.60000			
PT3		0.94921	0.94903	0.94886	0.94848	0.94810	0.94738			
		0.94570	0.93983	0.92445	0.90244	0.87191	0.83963			
AOAC		1.33598	1.18456	1.09082	1.03445	1.00478	0.99520			
		1.00131	0.99590	0.98929	0.98612	0.98010	0.98171			
CDA		0.16103	0.04360	0.00179	-0.00798	-0.00417	0.00302			
		0.00082	-0.00001	-0.00001	-0.00000	0.00000	-0.00001			

FIGURE 13-CONTINUED

AM	7.	0.50000	0.60000	0.70000	0.80000	0.90000	1.00000
		1.10000	1.20000	1.30000	1.40000	1.50000	1.60000
PT3		0.94312	0.94290	0.94268	0.94221	0.94173	0.94105
		0.93957	0.93625	0.92791	0.90936	0.88059	0.85077
AOAC		1.32741	1.17690	1.08372	1.02761	0.99804	0.98854
		0.99482	1.01345	1.00934	1.00729	1.00092	1.00514
CDA		0.14846	0.03123	-0.00742	-0.01434	-0.00714	0.00327
		0.00908	0.00230	-0.00001	-0.00001	-0.00001	-0.00001
AM	10.	0.50000	0.60000	0.70000	0.80000	0.90000	1.00000
		1.10000	1.20000	1.30000	1.40000	1.50000	1.60000
PT3		0.93428	0.93407	0.93385	0.93337	0.93290	0.93240
		0.93137	0.92874	0.92380	0.91275	0.88841	0.86219
AOAC		1.31498	1.16588	1.07357	1.01797	0.98868	0.97946
		0.98613	1.00531	1.03477	1.02850	1.02368	1.03154
CDA		0.13159	0.01717	-0.01901	-0.02254	-0.01176	0.00191
		0.01228	0.01355	0.00144	-0.00001	-0.00001	-0.00001
AM	13.	0.50000	0.60000	0.70000	0.80000	0.90000	1.00000
		1.10000	1.20000	1.30000	1.40000	1.50000	1.60000
PT3		0.92910	0.92862	0.92815	0.92767	0.92720	0.92644
		0.92543	0.92347	0.91959	0.91334	0.89973	0.87915
AOAC		1.30768	1.15909	1.06701	1.01175	0.98264	0.97320
		0.97985	0.99961	1.03005	1.06971	1.06043	1.07403
CDA		0.11963	0.00643	-0.02904	-0.02878	-0.01569	-0.00027
		0.01222	0.01857	0.01383	-0.00516	-0.00001	-0.00001
AM	16.	0.50000	0.60000	0.70000	0.80000	0.90000	1.00000
		1.10000	1.20000	1.30000	1.40000	1.50000	1.60000
PT3		0.92356	0.92291	0.92226	0.92174	0.92121	0.92031
		0.91933	0.91790	0.91497	0.91012	0.90363	0.88862
AOAC		1.29988	1.15195	1.06024	1.00528	0.97629	0.96676
		0.97339	0.99358	1.02488	1.06593	1.11646	1.10768
CDA		0.10376	-0.00621	-0.03968	-0.03593	-0.02040	-0.00309
		0.01146	0.02030	0.02091	0.00961	-0.01246	-0.00000

FIGURE 14
 INLET PERFORMANCE CHARACTERISTICS - TURBOJET-BOTTOM CENTERLINE-12. DEG RAMP
 INLET DESIGN MACH NO.=2.00)12.0 DEG RAMP*, TURBOJET, BOTTOM CENTERLINE

AV	3 8 MACH	PT3	AOAC	CDA	EXT.COMPR.	12.00,	0.01,	0.01	DEG.RAMPS,	2.00
AV	-5.00000	-2.00000	1.00000	4.00000	7.00000	10.00000				
	13.00000	16.00000								
7 7 7 7 7 7 7										
AM	-5.	0.50000	0.75000	1.00000	1.25000	1.50000	1.75000			
		2.00000								
PT3		0.95000	0.95000	0.94928	0.93734	0.92189	0.88398			
		0.81096								
AOAC		0.99519	0.76913	0.74220	0.76713	0.83263	0.89514			
		0.94814								
CDA		-0.06236	-0.03973	0.08460	0.11261	0.03383	0.01099			
		-0.00000								
AM	-2.	0.50000	0.75000	1.00000	1.25000	1.50000	1.75000			
		2.00000								
PT3		0.95000	0.95000	0.94959	0.94002	0.92274	0.89108			
		0.82252								
AOAC		0.99519	0.78913	0.74245	0.76932	0.84131	0.91061			
		0.97046								
CDA		-0.04242	-0.03604	0.08708	0.12773	0.04824	0.01574			
		-0.00000								
AM	1.	0.50000	0.75000	1.00000	1.25000	1.50000	1.75000			
		2.00000								
PT3		0.94980	0.94967	0.94916	0.94094	0.91547	0.89546			
		0.83397								
AOAC		0.99499	0.78885	0.74211	0.77008	0.84158	0.92524			
		0.99535								
CDA		-0.03112	-0.03114	0.09464	0.14662	0.07479	0.02257			
		-0.00000								
AM	4.	0.50000	0.75000	1.00000	1.25000	1.50000	1.75000			
		2.00000								
PT3		0.94921	0.94867	0.94738	0.93895	0.90930	0.89331			
		0.84181								
AOAC		0.99436	0.78802	0.74072	0.76845	0.83620	0.93678			
		1.01919								
CDA		-0.04660	-0.02325	0.11305	0.17533	0.11987	0.03436			
		0.00220								

FIGURE 14-CONTINUED

AM	7.	0.50000	0.75000	1.00000	1.25000	1.50000	1.75000
		2.00000					
PT3		0.94312	0.94245	0.94105	0.93368	0.90616	0.88109
		0.84898					
AOAC		0.98798	0.78286	0.73577	0.76414	0.83331	0.94470
		1.05120					
CDA		-0.06802	-0.01580	0.13537	0.21133	0.17680	0.06580
		0.01186					
AM	10.	0.50000	0.75000	1.00000	1.25000	1.50000	1.75000
		2.00000					
PT3		0.93428	0.93361	0.93240	0.92662	0.90227	0.85850
		0.84767					
AOAC		0.97873	0.77552	0.72900	0.75836	0.82973	0.93065
		1.07906					
CDA		-0.09806	-0.01820	0.15948	0.24597	0.23281	0.13334
		0.03520					
AM	13.	0.50000	0.75000	1.00000	1.25000	1.50000	1.75000
		2.00000					
PT3		0.92910	0.92791	0.92644	0.92183	0.90436	0.86849
		0.84093					
AOAC		0.97330	0.77078	0.72435	0.75444	0.83165	0.94148
		1.09833					
CDA		-0.09792	0.00392	0.17696	0.27158	0.28102	0.21541
		0.08514					
AM	16.	0.50000	0.75000	1.00000	1.25000	1.50000	1.75000
		2.00000					
PT3		0.92356	0.92200	0.92031	0.91668	0.90363	0.87447
		0.82783					
AOAC		0.96749	0.76587	0.71956	0.75022	0.83098	0.94797
		1.09223					
CDA		-0.09956	0.01627	0.19293	0.29275	0.31795	0.27763
		0.15740					

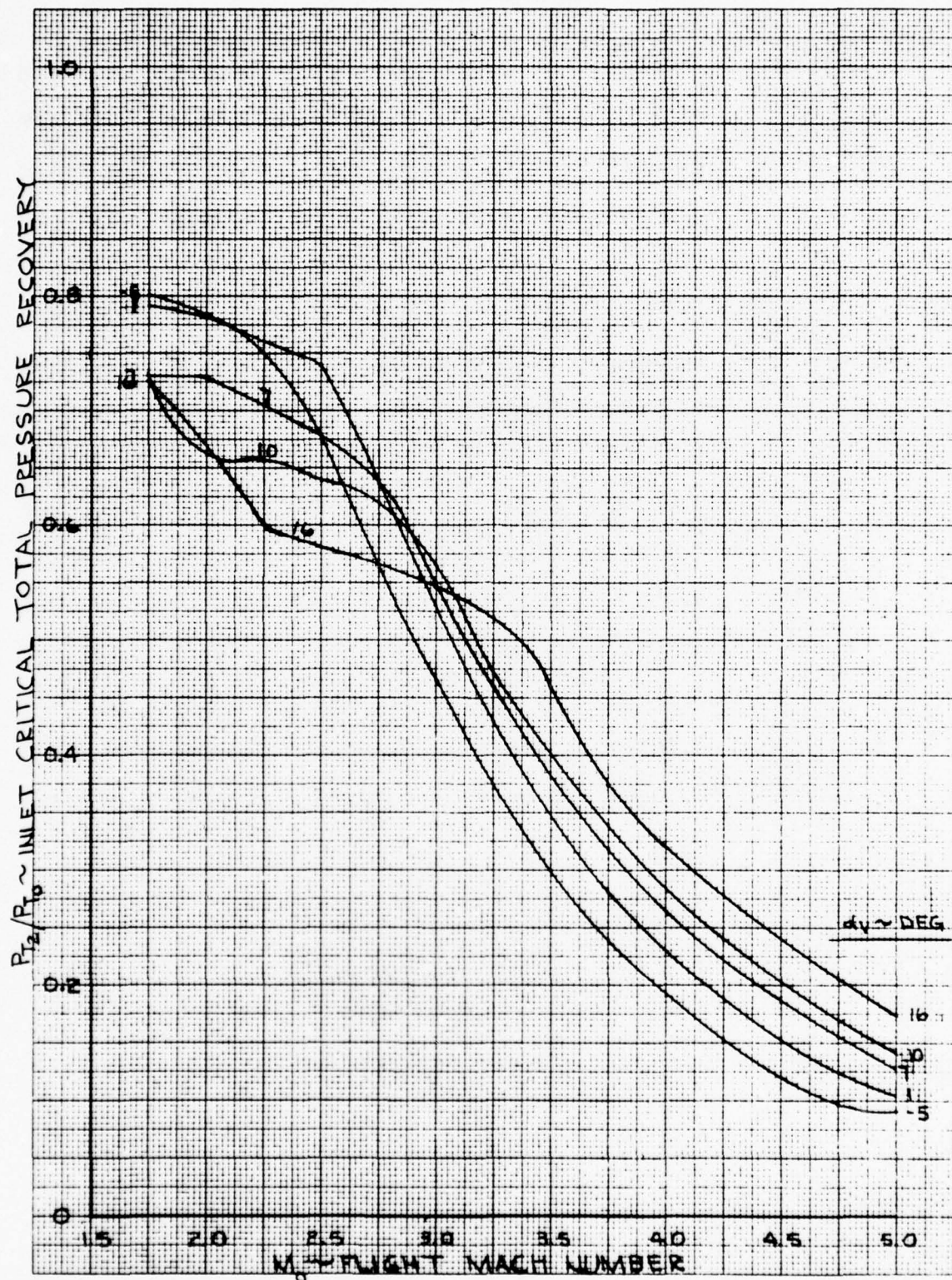

FIGURE 15. TOTAL PRESSURE RECOVERY - DUAL AFT, INLET DESIGN MACH NUMBER OF 2.5

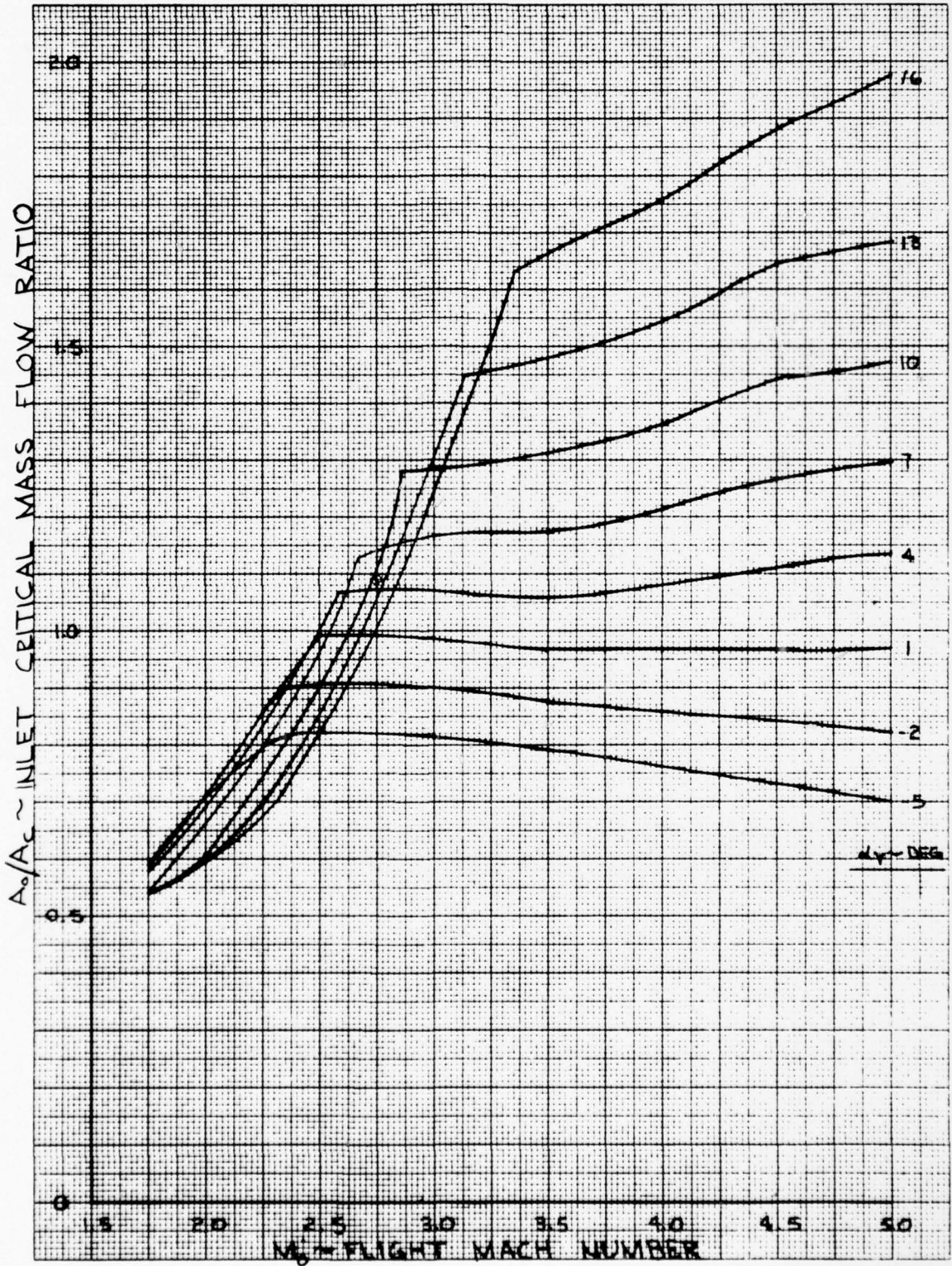

FIGURE 16. CRITICAL MASS FLOW RATIO - DUAL AFT, INLET DESIGN MACH NUMBER OF 2.5

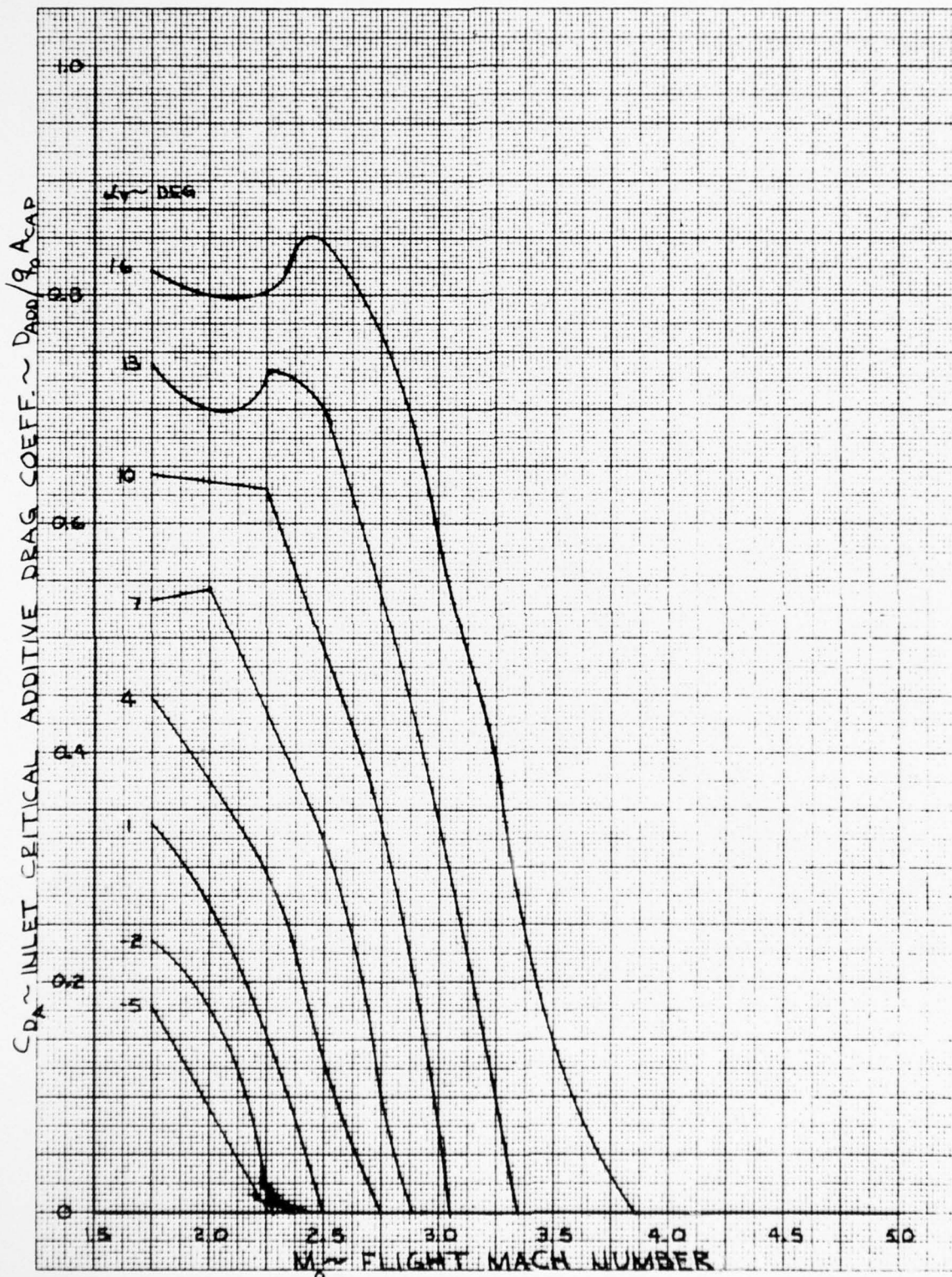

FIGURE 17. CRITICAL ADDITIVE DRAG - DUAL AFT, INLET DESIGN MACH NUMBER OF 2.5

Figure 16 presents the inlet critical mass flow ratio. The curves exhibit the typical characteristics, with the break in the curves indicating that all inlet shocks have fallen inside the cowl lip. At Mach numbers above the break point (at a constant vehicle angle of attack), the change in critical mass flow ratio is due to the forebody compression effect, i. e. , $(A_O/A_C) = (A_L/A_C)(A_O/A_L)$, the product of forebody compression effects (A_O/A_L) and the inlet local capture ratio (A_L/A_C) . At Mach numbers less than the break point, the increase is due to both forebody compression and the inlet compression shocks attaching to the inlet lip.

Figure 17 presents the inlet critical additive drag. At low flight Mach numbers and large angles of attack, the inlet spills large amounts of air and hence develops large additive drags. As the Mach number increases, the inlet shocks become attached and the additive drag is reduced. Eventually, all inlet shocks fall inside the cowl lip and the additive drag is reduced to zero.

2.2 Turbojet Inlet Sizing and Airflow Matching

The inclusion of the turbojet as a possible propulsion system requires a calculation of the inlet/engine airflow matching point and any reduction in engine thrust due to either additive drag (subcritical or critical) or supercritical operation. The subroutine INLET was developed to do this.

On the first pass through INLET, the inlet capture area is determined based upon the required engine corrected airflow, inlet design (normal shock or single compression surface), and critical total pressure recovery. With the capture area established, any desired number of off-design points can be examined. The required inlet mass flow ratio is determined, based upon inlet capture area, critical total pressure recovery, required engine airflow, and flight Mach number. If the required inlet mass flow ratio is less than the inlet critical mass flow ratio, then the subcritical additive drag for the condition being examined is calculated, and the total pressure recovery remains at the critical value. If the required inlet mass flow ratio exceeds the inlet critical mass flow ratio, then the resulting operating total pressure recovery to satisfy the engine demand is determined. The additive drag is equated to the critical additive drag, and an indication of supercritical operation is made. These three items are returned to the turbojet engine performance section where a decision is made as to whether or not the inlet should be resized.

2.3 Inlet Weight and Inertial Properties

This subroutine (INLETP) calculates the weight, center of gravity (c. g.), and pitch plane moment of inertia for the selected inlet. It also calculates wetted areas, projected areas, and boundary layer diverter heights required for the calculation of inlet drag.

The initial part of the program determines the geometry of the inlet cowl lip. At the design point, the internal cowl lip angle is determined by the criteria that there be an attached shock. A one-degree factor of safety is added. A seven degree included lip angle is used to determine the initial cowl external angle. Next, for the ramjet and combined cycle propulsion systems, the ratio of dump area to inlet throat area is determined at the inlet design point. A dump Mach number of 0.3 is assumed. For a turbojet propulsion system, the length of the subsonic diffuser is calculated, assuming an equivalent conical angle of 3.5 deg ($2\theta=7^\circ$).

Next, those calculations dependent upon actual inlet size are performed. The inlet aspect ratio is defined, as are the missile reference area and the required capture area as well as different missile component lengths. With these dimensions the inlet width and height are determined. The internal cowl angle is then reduced to zero degrees at the rate of ten degrees per throat height, to determine a "cowl turnback" distance. This axial distance is then used together with an angle that is one-half of the initial cowl lip internal angle to determine the cowl projected height. The increase in centerbody height from (X4, Y4) (the point where a line that is normal to the final compression ramp and passes through the cowl lip tip intersects the ramp) is then set equal to the increase in cowl projected height. This turnback region is followed by a region that is two throat heights long and has one degree divergence. Finally, the centerbody height at the end of the throat region is reduced to zero by a subsonic diffuser with a seven degree angle for the ramjet and combined cycle propulsion systems. For the turbojet propulsion system, the previously calculated subsonic diffuser length is used.

The dump port into the combustion chamber starts at the juncture of the rocket dome and its cylindrical section for the ramjet propulsion system. The equivalent station is used for the combined cycle propulsion system. Using this station, a check is made to determine the location of the inlet leading edge relative to the missile tangency point. If the inlet leading edge is forward of the tangency point, the calculations cease. For an acceptable inlet location with the ramjet or combined cycle propulsion system, the required length

of the dump port is then determined. For the turbojet propulsion system, the equivalent station is the engine face plus a constant area section that has a length of one engine face outer diameter. The distance from the forward edge of the dump port to the nozzle exit plane is then allotted for aft fairing length. Next, the boundary layer thickness at the inlet leading edge is calculated. A fully turbulent flat plate boundary layer is assumed, at the inlet design Mach number and zero altitude. An alternate altitude may be specified. The boundary layer diverter height is specified as 75% of the boundary layer thickness. Next, the boundary layer diverter projected and wetted areas are calculated. The next item considered is the forward fairing. A fineness ratio of 3.0 is used for the forward fairing unless the forward tip of such a fairing would extend forward of the tangency point. In that case, the forward tip of the fairing is located at the tangency point, and the resulting fineness ratio is used.

With the geometry of the inlet now fully specified, it is considered made up of 43 individual pieces. Pieces 1 through 5 and 7 through 11 comprise the inlet sideplate. Pieces 6, 12, 15, and 17 comprise the aft fairing. The cowl side of the inlet consists of pieces 13 and 14, and the upper surface is piece 16. Pieces 18 through 26 comprise the center web of the inlet, and pieces 27 through 32 comprise the inlet floor. Piece 33 is the piece of ducting ending at the end of the dump port. Pieces 34, 35, 39, and 40 make up the boundary layer diverter, and pieces 36, 37, 38, 41, 42, and 43 comprise the forward fairing. The wetted area and weight of each piece are determined. The inlet center of gravity is calculated, as are the inlet weight and wetted area. The pitch moment of inertia of the inlet is then calculated. If a turbojet propulsion system is used, the effect of the one diameter long constant area section is included in the weight, c. g., and moment of inertia calculation. The wetted area and projected areas including the boundary layer diverter are used to calculate the inlet drag in subroutine CDINLT.

The above mentioned 43 pieces of the inlet are computed in the Model based on scaling factors such as in Table I and Figure 3. See Vol. IIIA Users Manual for input formats.

APPENDIX F
RAMJET SIZING MODEL

TITLE:

RAMJET SIZING MODEL

Appendix F

NO. _____

DATE _____

TABLE OF CONTENTS

<u>Section</u>		<u>Page</u>
1.	INTRODUCTION	F-3
2.	FUNDAMENTALS OF RAMJET OPERATION.	F-4
3.	DESCRIPTION OF THE SEATIDE RAMJET PROPULSION MODEL.	F-26
4.	TECHNICAL DESCRIPTION AND MATH MODELS	F-41

LIST OF ILLUSTRATIONS

<u>Figure</u>		<u>Page</u>
1	Ramjet Engine Schematic	F-5
2	Two-Dimensional Diffuser	F-6
3	Best-Stagnation-Pressure Ratio	F-7
4	Selection of the Inlet Design Point.	F-8
5	Pressure Recovery and Mass Flow Data.	F-10
6	Temperature Rise Data	F-12
7	Temperature Rise Efficiency.	F-13
8	Ramjet Operation.	F-17
9	Typical Ramjet Design Point Map.	F-19
10	Ramjet Design Point Selection for Multi-Altitude Operation	F-21
11	Design Point Selection for Multi-Purpose Ramjet.	F-23

PREPARED BY *L. D. Gregory*
APPROVED BY L. D. Gregory (LKG)

PAGE 1 OF 98

TABLE OF CONTENTS (Cont'd.)

LIST OF ILLUSTRATIONS (Cont'd.)

<u>Figure</u>		<u>Page</u>
12	Thrust Variation with Capture Area and Temperature	F-24
13	Performance of a Multi-Purpose Design.	F-25
14	Ramjet Propulsion Model Logic Flow Subroutine PROPXX.	F-31-35
15	Ramjet Propulsion Model Logic Flow Subroutine PROPRJ.	F-36-40
16	Schematic Diagram of a Ramjet Propulsion System	F-45
17	Ramjet Nozzle	F-63
18	Splice Ring Model.	F-75
19	Liquid Gas Generator Mass Fraction	F-78
20	Liquid Gas Generator Volume	F-79

LIST OF TABLES

<u>Table</u>		<u>Page</u>
I	Equation Summary for Subroutine RJDES	F-57
II	Combustor MOI and CG Modeling	F-69
III	Sustain MOI and CG Modeling	F-83
IV	Material Properties	F-88
V	Standardized Geometry Modules	F-89
VI	Ramjet Propulsion Notation	F-96-98

APPENDIX F
RAMJET SIZING MODEL

1.0 INTRODUCTION

This appendix discusses the ramjet sizing model. That discussion is divided among the following three sections. The first, Section 2, discusses fundamentals of ramjet operation, describes ramjet components and examines several ramjet design problems in general terms. Section 3 discusses the capabilities of the Seatide Ramjet Model and the overall flow of the computer model. Section 4 presents the math models and derivation of the equations used in the computer subroutines.

2.0 FUNDAMENTALS OF RAMJET OPERATION

The purpose of this section is to introduce the reader to ramjet design fundamentals while avoiding as far as possible the mathematics of a rigorous presentation. A complete derivation of equations contained in the Seatide ramjet propulsion model will be presented in Section 5.0 of this appendix.

2.1 Basic Ramjet Operation

The ramjet engine is the simplest of all airbreathing engines. As shown schematically in Figure 1, it consists of an inlet, a diffuser, a combustion chamber and a nozzle. Air enters the inlet where it is compressed before it is mixed with the fuel and burned in the combustion chamber. The hot gases are then expelled through the nozzle by virtue of the pressure rise in the diffuser. Consequently, although ramjets can operate at subsonic flight speeds, the increasing pressure rise accompanying higher flight speeds renders the ramjet most suitable for speeds above Mach 2.0.

Figure 1 is typical of supersonic ramjets which employ partially supersonic diffusion through a system of shocks. Since the combustion chamber requires an inlet Mach number of about 0.3 to 0.4, the pressure rise at supersonic flight speeds can be substantial. For example, for isentropic deceleration from $M = 3$ to $M = 0.3$, the static pressure ratio between ambient and combustion chamber pressures would be about 34. Only a fraction of the isentropic pressure ratio is actually achieved since, especially at high Mach numbers, the stagnation pressure losses associated with shocks are substantial. After compression the air flows past the fuel injectors, which spray a stream of fine fuel droplets so that the air and fuel mix as rapidly as possible. The mixture then flows through the combustion chamber which may contain a "flameholder" to stabilize the flame, much as is indicated in Fig. 1. Combustion raises the temperature of the mixture to perhaps 4000°R before the products of combustion expand to high velocity in the nozzle. The reaction to the creation of the propellant momentum is a thrust on the engine. This thrust is actually applied by pressure and shear forces distributed over the surfaces of the engine.

Figure 1 shows a centerbody inlet such as was used on Talos and Bomarc. Current designs are more likely to employ aft side mounted inlets, a belly inlet or a chin inlet. These configurations leave the centerbody free for the payload, guidance system, and fuel tanks. The diffusers duct the air down the side of the engine and dump it into the combustion chamber through a 45° to 90° turn. The turn and dump degrade the pressure recovery somewhat but when properly designed set up flow conditions which eliminate the need for flameholders.

RAMJET ENGINE SCHEMATIC

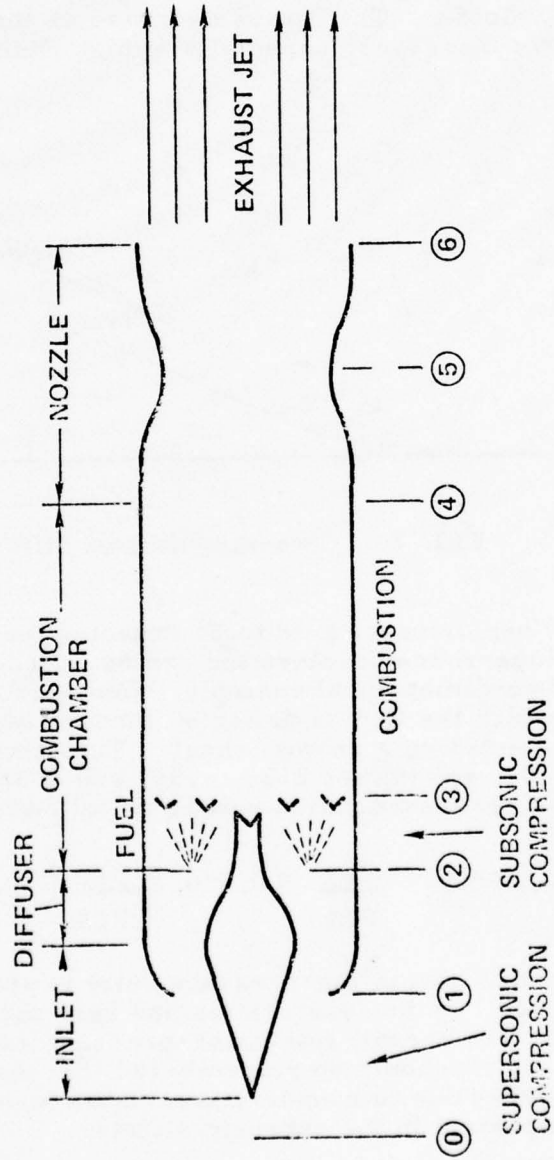

Figure 1

2.2 Inlet Operation

For ramjet operation it is necessary to slow the entering air stream to a subsonic value of Mach 0.3 - 0.4. The simplest and most practical external deceleration mechanism is an oblique shock or, in some cases, a series of oblique shocks. While such shocks are not isentropic, the stagnation-pressure loss in reaching subsonic velocity through a series of oblique shocks followed by a normal shock is less than that accompanying a single normal shock at the flight velocity. The losses decrease as the number of oblique shocks increases, especially at high flight Mach numbers.

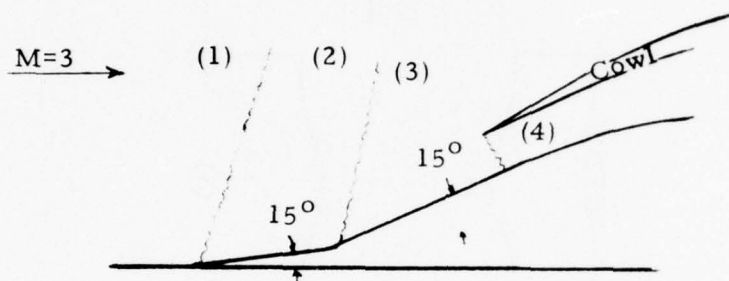

FIG. 2 Two-dimensional diffuser

The performance gain to be expected through the use of multiple oblique-shock deceleration can be appreciated by looking at a simple two-dimensional example. Consider the diffuser in Figure 2 in which the flow is deflected through two 15-degree angles before entering a normal shock. The Mach numbers in regions (2), (3), and (4) are 2.26, 1.36, and 0.36, respectively. The stagnation-pressure ratios will be as follows:

$$\frac{P_{02}}{P_{01}} = 0.900, \quad \frac{P_{03}}{P_{02}} = 0.950, \quad \frac{P_{04}}{P_{03}} = 0.960.$$

Thus, the overall stagnation-pressure ratio is approximately $P_{04}/P_{01} = 0.820$. If the deceleration had been achieved by a single normal shock, the overall stagnation-pressure ratio would have been only 0.33. It should be remembered that these estimates do not include losses due to boundary layer effects, which may be especially important in the subsonic diffuser.

This example does not necessarily employ the best arrangement of these shocks since a variation of their relative strengths might provide a higher overall stagnation pressure ratio. Figure 3 shows ideal performance from an inlet of n ramps followed by a normal shock.

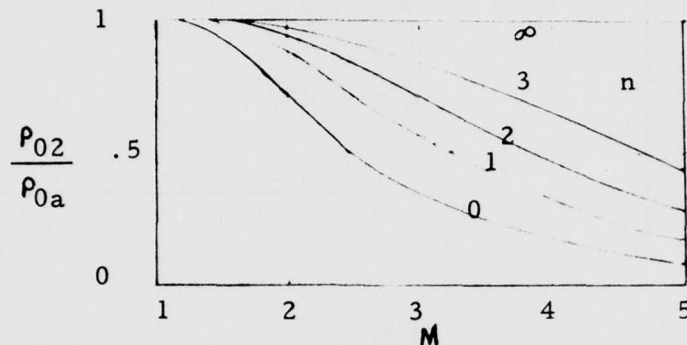

Fig. 3 Best stagnation-pressure ratio for diffuser consisting of n oblique shocks of uniform strength and one normal shock; $\gamma = 1.4$. (After Oswatitsch)

In the external compression process, shocks and boundary layers may interact strongly, so that it is highly desirable to locate the oblique shocks at points where boundary layers are absent. This can be arranged easily if a center body (primarily for axisymmetric flow) is used, as in Figure 1. For an aft inlet configuration a boundary layer diverter is normally placed between the inlet and the missile body in order to raise the inlet above the boundary layer. Inlet performance is further improved if the boundary layer developed on the inlet ramps is "bled" off prior to the normal shock. The bleed fraction is typically 3-5% of the total air flow.

Figure 2 shows an inlet where oblique shocks generated by the inlet ramps extend outward beyond the inlet cowl. When this happens compression work is done on air which is not captured by the inlet and hence the effective drag of the inlet is increased. This phenomenon, termed "additive drag", will be present whenever the oblique shocks generated by the inlet ramps are not completely swallowed. Consequently inlet design calls for both oblique shocks to intersect at the cowl lip at a pre-selected Mach number termed the "inlet design Mach number". As the shock angles become more acute with increasing Mach number, additive drag will be present at velocities below the inlet design Mach number and will be absent above the inlet design Mach number. This is shown schematically at the top of Figure 4.

SELECTION OF THE INLET DESIGN POINT

Figure 4

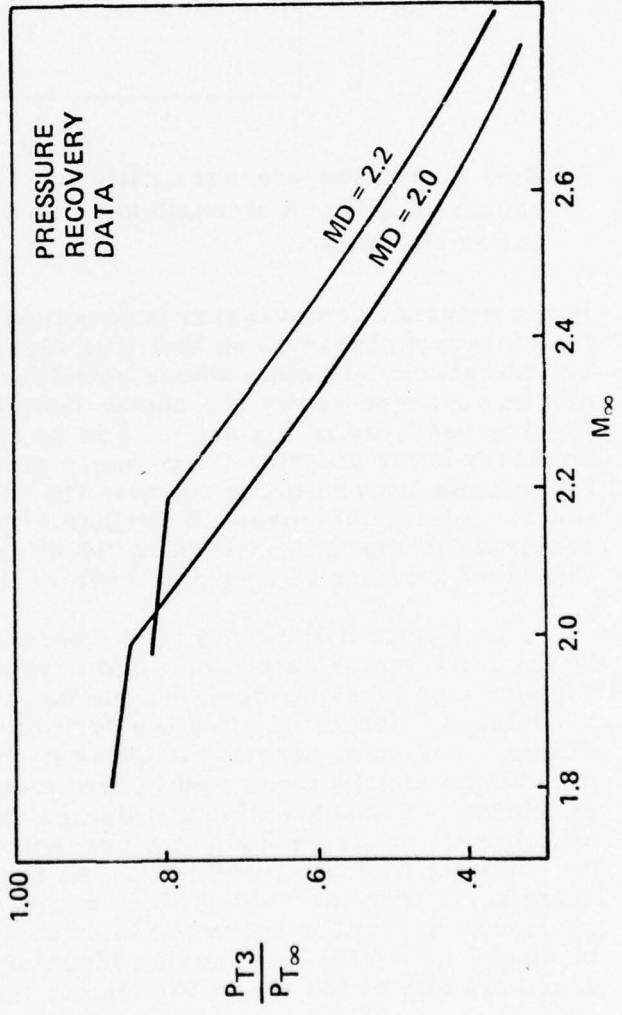
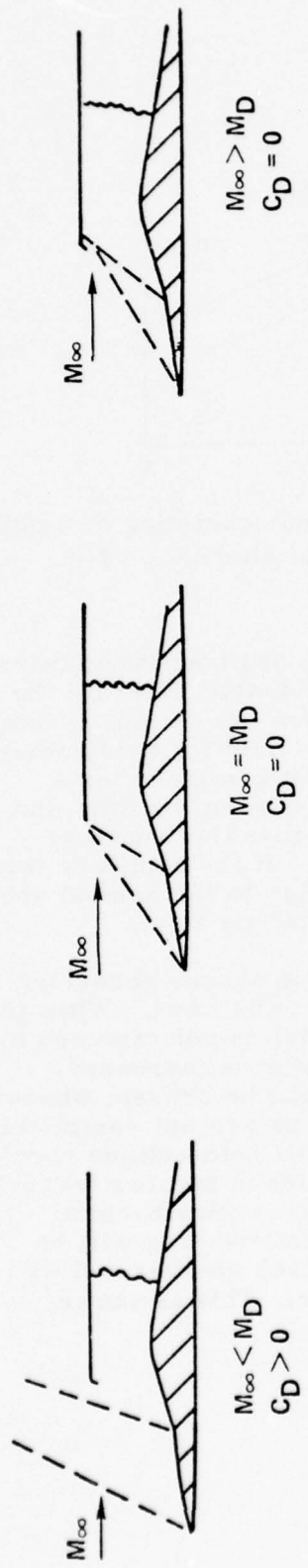

Effect of Inlet Design Mach Number (M_D) on Additive Drag (C_D) and Pressure Recovery $\frac{P_{T3}}{P_T}$.

Additive drag can be avoided by designing the inlet at the lowest Mach number at which the ramjet will be expected to operate. As shown by Figure 4, this would result in poorer pressure recovery over most of the vehicle performance envelope. Selection of the inlet design Mach number is a trade between additive drag on one hand and pressure recovery on the other. It is suggested that the inlet design Mach number be initially selected at or near the lowest Mach number at which the ramjet must operate. This will degrade inlet performance at higher Mach numbers but it often happens that the combustor cannot use all of the available pressure recovery at high Mach numbers (as discussed below). In these cases conditions at the low Mach number will dictate the ramjet design and the selected inlet design Mach number will be optimum. For cases where the ramjet design is dictated by Mach numbers above the lowest Mach number, vehicle performance can be improved by increasing the inlet design Mach number.

Design of an inlet for optimum pressure recovery involves selection of ramp angles. Figure 2 shows an inlet with two ramps of 15° each. In general free stream flow will be parallel to the centerline of the inlet only at one vehicle angle of attack (zero degrees if the inlet is aligned with the centerline of the vehicle). At all other angles of attack the first ramp will effectively be greater or less than the design angle. Consequently, pressure recovery and additive drag will be functions of angle of attack as well as Mach number. Angle of attack also changes the effective capture area and hence the mass flow characteristics of the inlet. Figure 5 shows pressure recovery and mass flow data for a dual aft inlet system. Data for four aft inlet and chin inlet systems would have substantially different characteristics. Inlet decks provided for SEATIDE provide pressure recovery, mass flow and additive drag data as a function of Mach number and angle of attack.

2.3 Combustor Operation

The working fluid in the engine is "heated" by an internal combustion process. Before this chemical reaction can occur, the liquid fuel must be injected into the airstream, atomized, vaporized, and the vapor must be mixed with the air. All this takes time and space. Space is of course at a premium in aircraft applications, so that great effort is made to reduce the size of the combustion chamber by hastening completion of the above processes. Very high combustion intensity is achieved in aircraft combustion chambers as compared with conventional combustion devices. This intensity must be achieved without sacrificing other equally important performance characteristics. Some of the desirable features of combustion chambers are as follows: (1) completeness of combustion, (2) proper temperature distribution at exit, (3) low stagnation-pressure loss, (4) absence of "hot spots", (5) stability, (6) freedom from flameout and (7) small cross section and length. Many of these requirements are incompatible. For example, high efficiency and low pressure loss are in direct opposition to small size.

SHOCK ON LIP AT 2.0
 $\alpha = +6^\circ$ TO $.4^\circ$

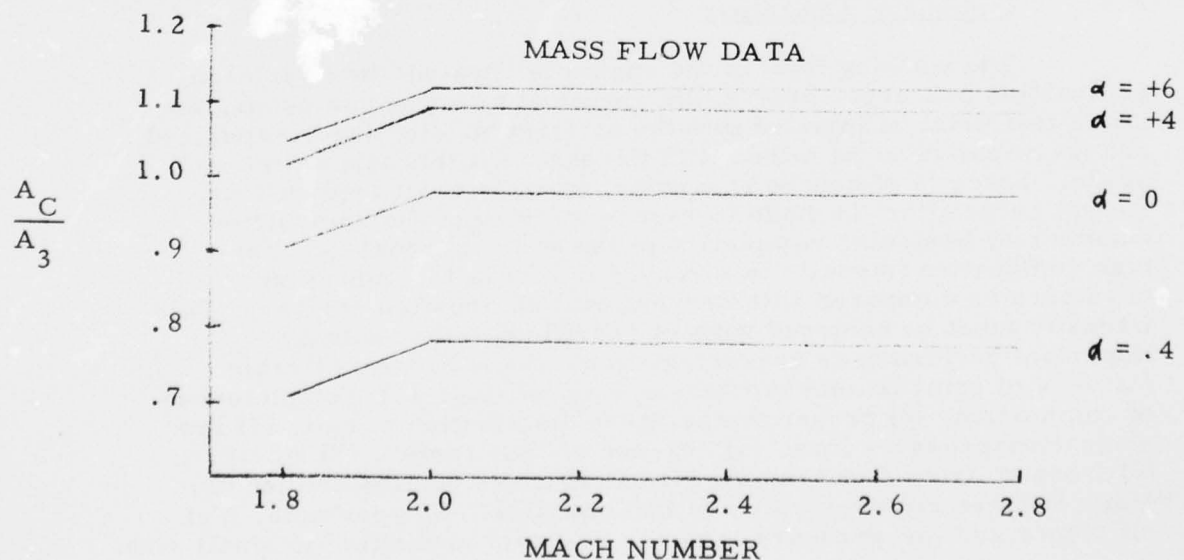
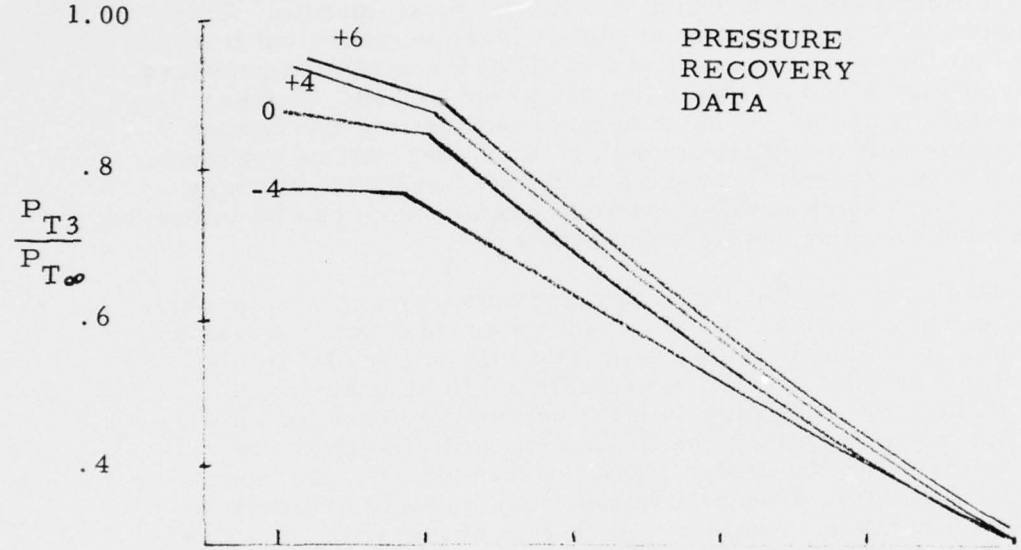

Figure 5 Pressure Recovery and Mass Flow Data

The temperature rise obtained in the combustion chamber depends on the fuel being used, the entering temperature of the air, the pressure at which combustion occurs and the combustion efficiency. Typical ideal temperature rise curves for entering total temperatures of 1200°R and 2000°R are shown in Figure 6. The maximum allowable fuel to air ratio is often limited to some value just below stoichiometric as fuel addition near stoichiometric produces only little temperature increase. For example JP5 may be limited to a fuel to air ratio of 0.06. A slightly higher temperature (100-200 degrees) could be obtained but only at an uneconomical fuel consumption rate.

The ratio of specific heats (γ) and the gas constant (R) are also functions of temperature, fuel to air ratio, and, weakly, pressure.

The correlating parameter generally used by the ramjet industry in estimating combustion efficiency is the burner severity parameter (BSP).

$$BSP = \frac{\dot{w}}{A_5} \left(\frac{T_{T_2}}{1000} \right)^2 \quad (1) \quad \begin{array}{l} \dot{w} = \text{air flow rate lbm/sec} \\ A_5 = \text{combustor throat area ft}^2 \\ T_{T_2} = \text{free stream total} \\ \text{temperature } ^\circ\text{R} \end{array}$$

Figure 7 shows a typical plot of combustion efficiency (η_c) as a function of BSP. The combustion temperature (T_{T_4}) is calculated as follows

$$T_{T_4} = (\Delta T_{\text{ideal}}) \eta_c + T_{T_2} \quad (2)$$

Also shown in Figure 7 is the "lean blow out" line. If the fuel to air ratio (F/A) is continually reduced a point will be reached at which combustion can no longer be maintained. When this happens "lean blow out" is said to have occurred. Lean blow out also correlated with the burner severity parameter. "Rich blow out" can also occur but as this occurs at fuel to air ratios in excess of stoichiometric it is of little practical significance.

Fuel decks supplied with the Seatide routine for use in ramjet design contain four tables, as follows:

1. Ideal temperature rise as a function of fuel to air ratio, entering total temperature, and pressure.
2. The ratio of specific heats (γ) as a function of fuel to air ratio, total temperature and pressure.
3. Gas constant as a function of fuel to air ratio, total temperature and pressure.

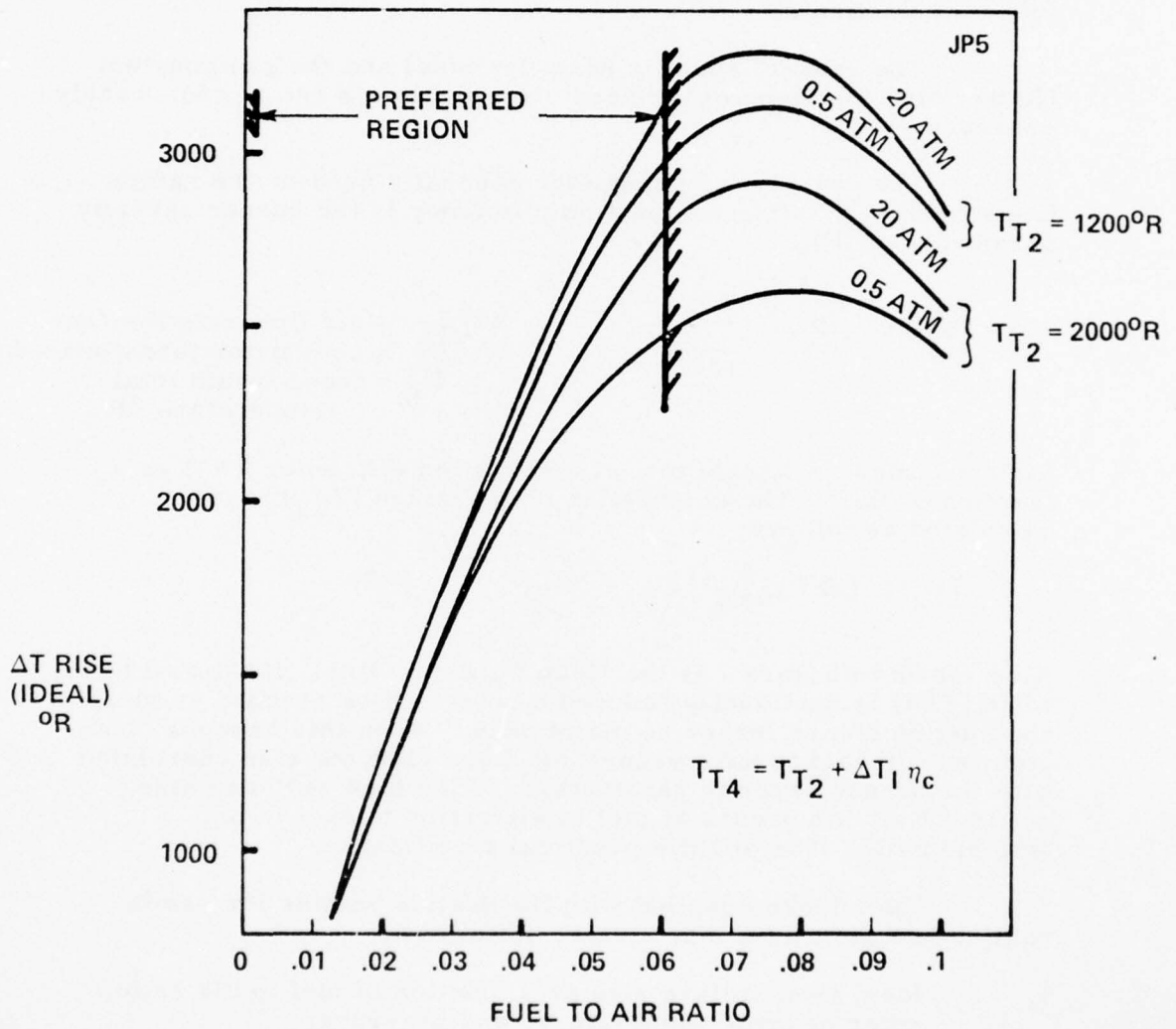
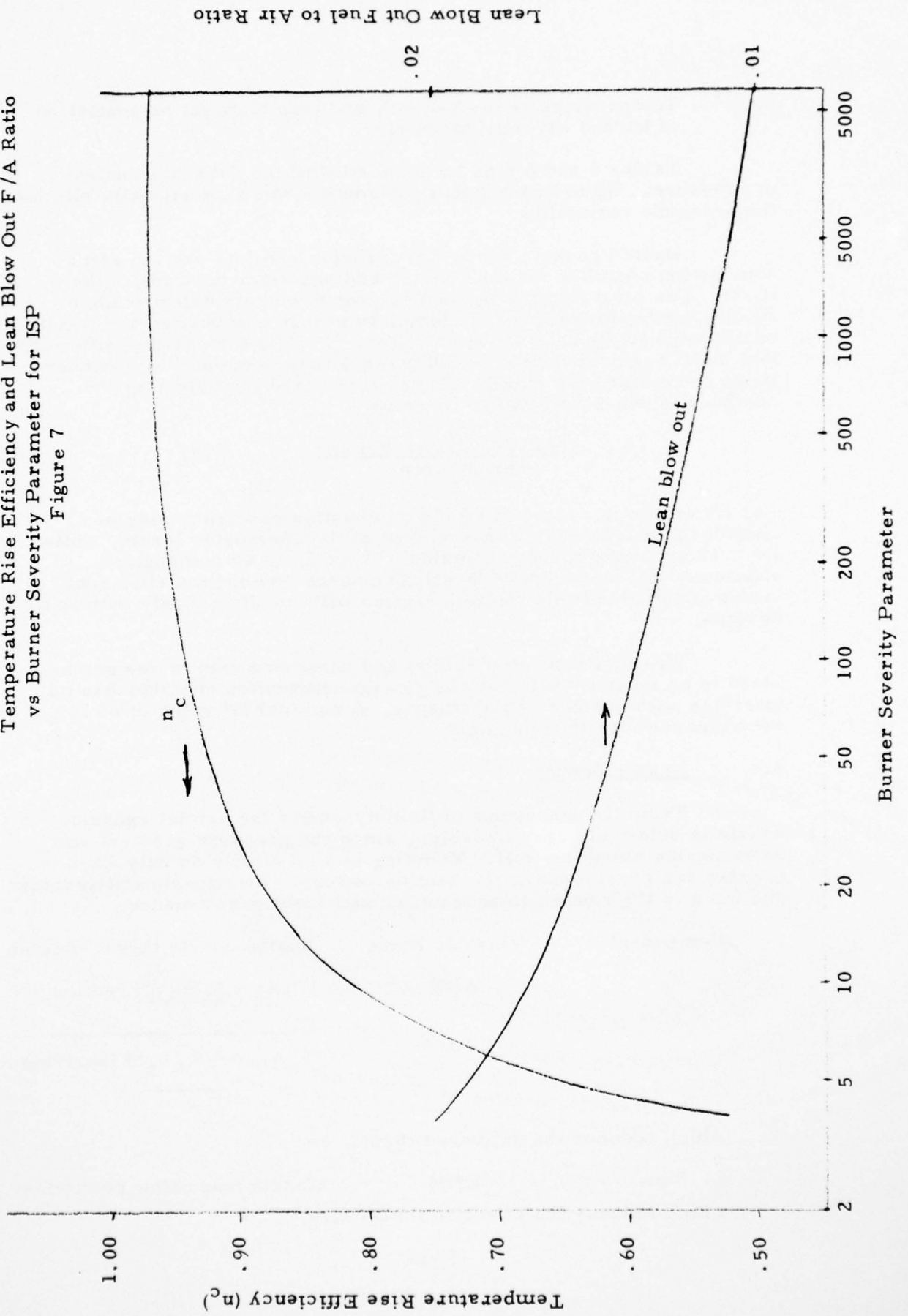

Figure 6 Temperature Rise Data

Temperature Rise Efficiency and Lean Blow Out F/A Ratio
 vs Burner Severity Parameter for ISP
 Figure 7



4. Temperature rise efficiency and lean blow out as a function of burner severity parameter.

Tables 2 and 3 may be supplied with the data independent of pressure. When this happens the routine will automatically eliminate the pressure variability.

Ducted rockets and integral rocket ramjets use the same combustion chamber for the booster and sustainer portions of the flight. For most designs the booster requirements will provide a ramjet combustor of adequate length to ensure combustion efficiencies comparable to the data shown in Figure 7. Only for designs with minimal boost requirements ($V \sim 800$ ft/sec) is the combustion chamber likely to be sized too small. The criteria used in evaluating the combustion dwell time is the L^* value

$$L^* = \frac{\text{Total Combustor Volume}}{\text{Throat Area}} \quad (3)$$

For L^* values in excess of 60 the combustion efficiency may be considered as effectively independent of the combustor length, while $L^* \approx 40$ are marginally acceptable. When $L^* < 40$ combustion efficiency will be severely penalized and the combustion efficiency tables supplied with the Seatide routine will result in highly optimistic designs.

Externally boosted ramjet and unboosted ramjet designs are sized to an input L^* value as the ramjet combustion chamber has no interface with booster requirements. A nominal L^* value of 60 is recommended for these designs.

2.4 Nozzle Design

From the standpoint of fluid dynamics the ramjet exhaust nozzle is relatively easy to design, since the pressure gradient can be favorable along the wall. Modeling is also simple as only fixed nozzles are considered in the Seatide routine. Two nozzle efficiencies are input to the routine to account for non-ideal performance:

Component	Variable Name	Engine nozzle thrust efficiency,
η_n	ANN	$\frac{(P_6 A_6 + \frac{P_6 A_6 V_6^2}{g})_{\text{actual}}}{(P_6 A_6 + \frac{P_6 A_6 V_6^2}{g})_{\text{isentropic}}}$

which reduces the delivered thrust, and

η_{nm}	CNM	Nozzle mass flow coefficient
which reduces the effective throat size.		

The exit area ratio (relative to the combustor diameter) may be restricted to lie within minimum and maximum values. To the extent that it can do so without violating these constraints, the routine will design the nozzle to provide expansion of the chamber gases to equal the ambient pressure at the design point. In selecting the maximum allowable exit area the user should realize that a booster nozzle retaining system may be required to fit within the combustor diameter. Consequently, a value no larger than 0.9 is recommended for integral rocket ramjets and ducted rockets.

2.5 Component Matching

Figure 5 is an example of critical pressure recovery data ($P_{T3}/P_{T\infty}$) for a particular inlet. Critical pressure recovery is the pressure recovery obtained when the normal shock (the shock between region 3 and 4 in Figure 2) is just inside the cowl lip. In practice the operational pressure recovery is generally somewhat less than critical for two reasons:

1. Because of manufacturing tolerances the inlet may produce less pressure recovery than the nominal critical value. To allow for this a manufacturing margin (typically 6-10%) is subtracted by the routine from the critical data. The differences between the critical value and the margin value are considered to be unobtainable under normal operating conditions.
2. The ramjet engine will generally be required to operate over a range of Mach numbers and altitudes. The ramjet will be designed to a margined critical pressure recovery at the design point but will operate at less than theoretical pressure recovery over much if not all of the off design regime. Less than theoretical pressure recovery operation is termed "supercritical operation". The mechanism for super-critical operation is explained below. The fundamental equation for flow through the combustor nozzle is:

$$\frac{\dot{w}}{A_5} = \frac{P_{T4}}{T_{T4}} \sqrt{\frac{gk}{R} \left(\frac{2}{K+1} \right)^{\frac{K+1}{K-1}}} \quad (4)$$

\dot{w} = mass flow
 A_5 = combustor throat

where

T_{T_4} = combustor total temperature

P_{T_4} = combustor total pressure

g = gravitational constant

R = gas constant

K = ratio of specific heats

The parameters K and R are second order dependent variables set by the fluid composition, pressure and temperature. \dot{w} is determined by capture area. Both capture area and throat area (A_5) were set to give marginal critical performance at the design point. Rewriting equation (4) as

$$P_{T_4} = \sqrt{T_{T_4}} \left\{ \frac{\dot{w}}{A_5} \sqrt{\frac{R}{gK} \left(\frac{2}{K+1} \right) \frac{K-1}{K+1}} \right\},$$

we see that pressure in the combustor will vary (approximately) directly with the square root of the temperature. The inlet is able to adjust the pressure recovery because of two physical laws:

1. Supersonic flow will accelerate in a diverging passage.
2. The higher the Mach number at which a shock occurs, the greater the resulting loss in total pressure.

The pressure recovery required to satisfy equation (4) is obtained by the combustor by adjusting the location of the normal shock (see Figure 2) in the diffuser. Flow upstream of the normal shock will be supersonic. Consequently, the further down the duct the normal shock is located, the higher the upstream Mach number will be in front of the shock, the more severe the shock and the greater the resulting pressure loss. The combustor can therefore position the normal shock in the inlet diffuser duct as required to produce the pressure recovery dictated by the value of T_{T_4} in equation (4). As T_{T_4} is increased the normal shock will be forced up the inlet duct until finally it stands at the cowl lip. The inlet is then producing critical (maximum obtainable) pressure recovery. Further increase in T_{T_4} requires pressure recoveries which cannot be achieved. When this happens equation (4) will be satisfied by reducing \dot{w} . The normal shock is pushed out of the inlet duct and sits outside the cowl lip (the inlet "unstarts"). Some of the air previously ingested is spilled and the inlet is said to act subcritically. Subcritical operation is often unstable and is not permitted by the SEATIDE ramjet model. Figure 8 shows supercritical, critical and subcritical operation schematically.

RAMJET OPERATION

$$P_{T4} = \sqrt{T_{T4}}$$

$$\dot{\omega} \frac{1}{A_5} \sqrt{\frac{R}{g\gamma} \left(\frac{2}{\gamma+1} \right)^{\frac{\gamma-1}{\gamma+1}}}$$

$$P_{T4} \sim \frac{\sqrt{T_{T4}} \dot{\omega} K}{A_5}$$

Descriptive equation

F-17

SUPERCritical



$$P_{T4} \ll P_{T4CRIT}$$

$$\dot{\omega} = \dot{\omega} CRIT$$

$$T_{T4} \ll T_{T4CRIT}$$

CRITICAL



$$P_{T4} = P_{T4CRIT}$$

$$\dot{\omega} = \dot{\omega} CRIT$$

$$T_{T4} = T_{T4CRIT}$$

SUBCRITICAL



$$P_{T4} \approx P_{T4CRIT}$$

$$\dot{\omega} < \dot{\omega} CRIT$$

$$T_{T4} > T_{T4CRIT}$$

Figure 8

2.6 Booster Sizing

In general the booster motor should be designed at the lowest altitude at which the vehicle must operate. As both the launch vehicle's maximum obtainable velocity and the booster motor's delivered velocity gain increase with altitude, the booster will over-boost the ramjet at altitudes greater than the minimum.

The end of boost Mach number must exceed the ramjet take-over Mach number. This is true for a number of reasons:

- (a) -3σ performance of the booster, ramjet and launch vehicle must be taken into consideration.
- (b) The ramjet will slow down during transition from boost to ramjet operation.
- (c) During hot days operation the ramjet performance will be degraded.

As a rule of thumb the ramjet should be able to take over at 0.2 Mach number below the end of boost Mach number. That is if the nominal ramjet can take over at Mach 1.8 the nominal booster must boost to Mach 2.0.

2.7 Ramjet Design Problems

2.7.1 Point Design

Figure 9 shows a ramjet map for an engine to be designed at Mach 4.0 and 80,000 ft and required to produce a thrust coefficient of .3. The lower limit of the allowable operational envelope is given by the 4000°R line. For the engine under consideration the margined critical (maximum) pressure recovery is 0.2075. This line forms the left boundary. The upper boundary results from the inability of the engine to develop the required CFN at lower temperatures and high mass flow rates. The right hand boundary occurs because the velocity in the combustor approaches Mach 1 as the throat area ratio approaches one. Any capture area and throat area combination which lie within the allowable operational envelope will result in a workable, if possibly inefficient, ramjet engine design. Data shown in this section were generated using LTV computer routines and inlet and fuel decks. While the lower and left boundaries are discrete, well defined lines, the upper and right boundaries are not. These boundaries can be accurately defined by an iterative use of the computer routine but are generally not of enough practical significance to warrant the effort. Hence, upper and right hand boundaries shown are approximations.

TYPICAL RAMJET DESIGN POINT MAP

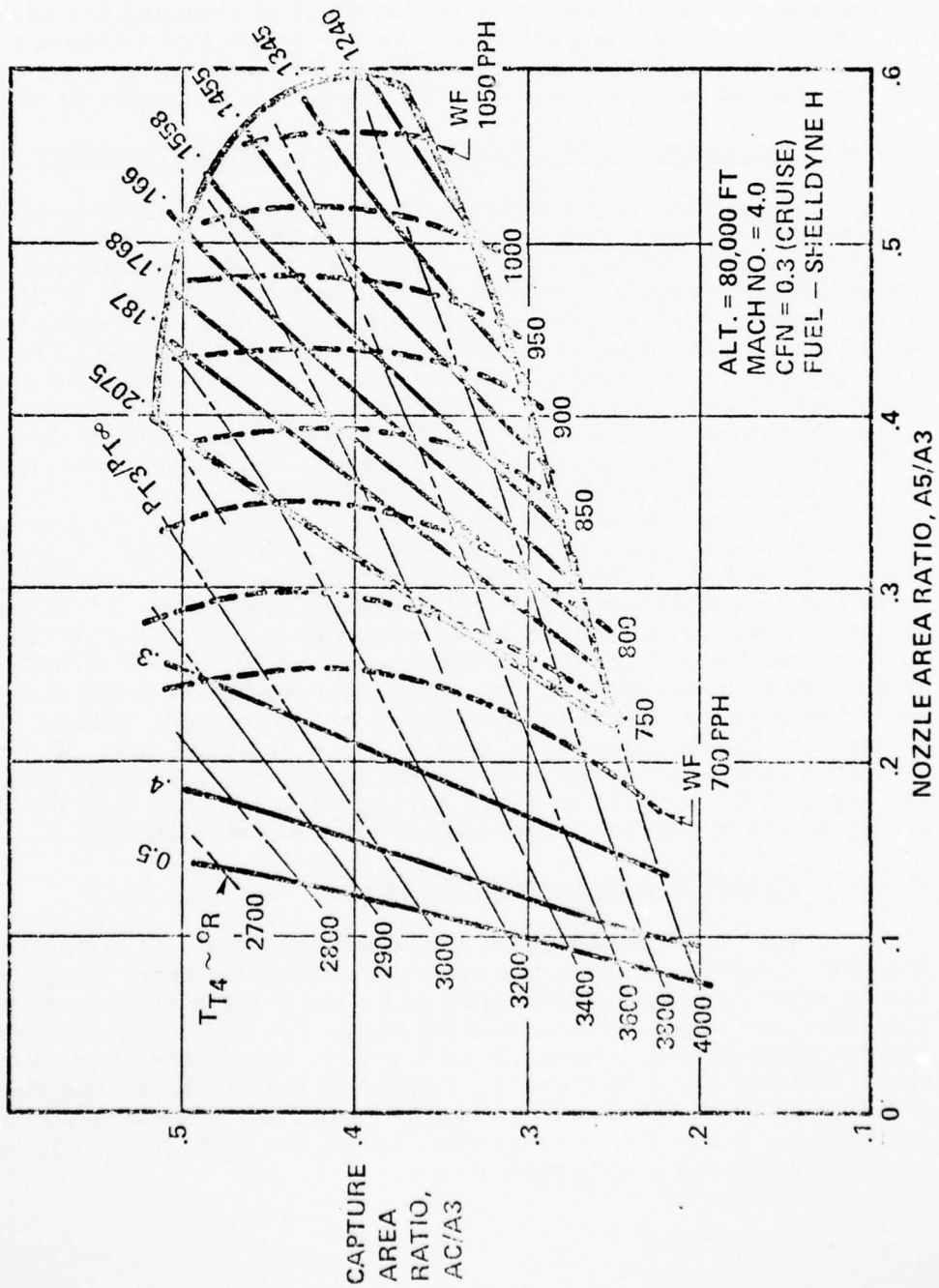

Figure 9

Lines of constant fuel flow (in pounds per hour) are shown as dashed lines. Their non-linear nature is due in part to the non-linear shape of the temperature rise curve and in part to pressure losses resulting from heat addition. On the map shown, increasing the temperature along a constant pressure line results in an increase in fuel flow. On other maps the reverse may be true. It is not possible to make a general statement as to the effect of changing temperature on fuel consumption; however, we can be certain that minimum fuel consumption required to produce a given CFN will occur somewhere on the critical pressure recovery line (.2075 in the example shown).

2.7.2 Designing for Multiple Altitudes and Mach Numbers

It is often required to design a ramjet which will operate at several Mach numbers and altitudes. It is then necessary to select a design point which will result in a design capable of functioning over the entire operational envelope. Unfortunately, selection of the design point performance is highly inlet dependent. Changing the inlet configuration will often result in changing the design point. An example can be developed using Figure 10, and assuming the design requirement is to size a ramjet engine which can produce a CFN of 0.3 at both Mach 2.5 and 500 feet and Mach 3.0 and 40000 feet. The solid line shows the operational envelope at Mach 2.5, 500 feet while the dashed line shows the Mach 3.0, 40000 feet envelope. The design point is there determined by the inlet performance. If the inlet could produce a usable pressure recovery of 0.4 at Mach 3 any design point selected along the critical Mach 2.5 ($P_{T3} / P_T = .6$) line would result in acceptable supercritical operation at Mach 3. If, however, the inlet could produce a pressure recovery of only .35 at Mach 3, any critical Mach 2.5, 500 ft design would result in subcritical performance at the high altitude point. As discussed previously, subcritical performance for ramjets is not permitted. Hence, in the latter case the design point should be Mach 3, 40000 feet. Of course, we could have avoided the entire issue by designing at some point to the right of the critical line (say $A_C/A_3 = 0.4$, $A_5/A_3 = 0.5$) but this would result in excessive fuel consumption at both points.

2.7.3 Design of Accelerating Ramjets

Ramjets operate at three to five times the ISP of booster motors. For this reason it is often possible to increase range by taking over with the ramjet engine at as low a Mach number as possible. Considerable emphasis has been placed on the trajectory wherein the ramjet takes over at around Mach 1.8-2.0, accelerates and climbs to 80,000 feet at Mach 4.0-4.5, cruises at that altitude, and dives to 500 feet at Mach 2.0-2.5 for a low level run in. This trajectory was selected for a special consideration during the SEATIDE study because of its significance and complexity.

RAMJET DESIGN POINT SELECTION FOR MULTI-ALTITUDE OPERATION

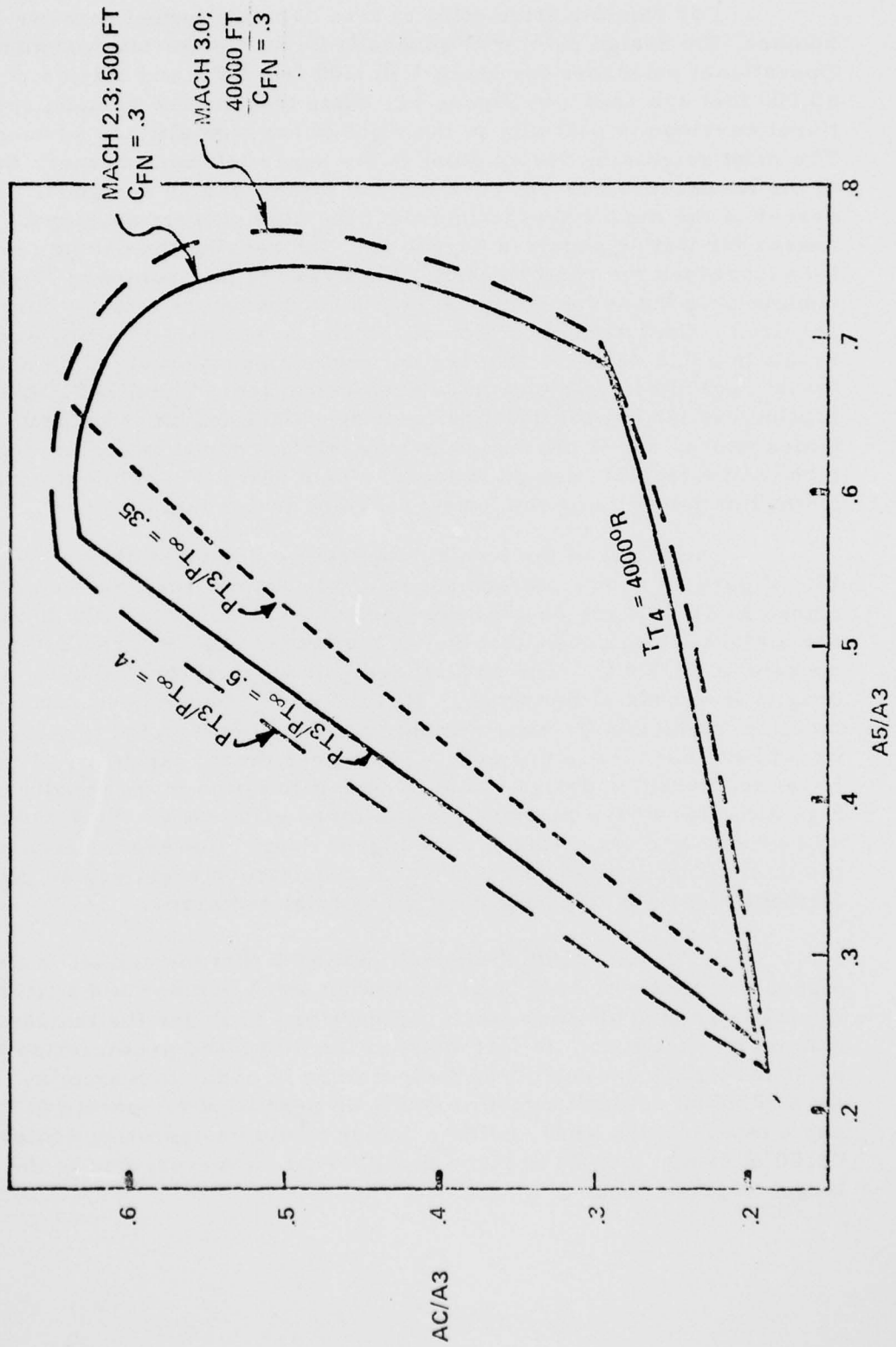

For ramjets attempting to take over the lowest feasible Mach number, the design point will generally be at the low Mach number. Operational envelopes for Mach 1.8, 500 feet CFN and Mach 4.5, 80,000 feet are shown in Figure 11. Note that the low altitude operational envelope is partially to the right of the high altitude envelope. The most promising design point is the upper left hand corner, that is, at the lowest temperature at which the ramjet can be designed. This corner is the most likely to intersect the high altitude envelope. The reason for this is shown in Figure 12. Decreasing the design temperature increases the capture area. This results in a somewhat higher vehicle drag but is beneficial at high altitudes where a large inlet is required. Continued reduction of the design temperature will eventually result in a "no design", that is, the engine cannot produce the required thrust regardless of the capture area permitted. The SEATIDE ramjet routine has the capability of calculating a trial design at an input temperature, and if the design is unfeasible, incrementing the temperature until a feasible design is found. This permits a semiautomated method of determining the lowest feasible design temperature.

The effect of the lower temperature design is shown in Figure 13. Figure 13 shows performances of two ramjet engines, one designed at 2100°R and another designed at 2500°R . The 2100°R design has a higher drag coefficient due to the larger capture area but can operate at 80,000 ft. The 2500°R design cannot fly at 80,000 ft. as the drag is in excess of the thrust. Had the 2500° design been capable of meeting the 80,000 ft. requirements a choice between the two engines would have been more difficult. The higher thrust capability of the lower temperature design would permit it to climb more rapidly to high altitudes where ramjets operate more efficiently. This advantage will generally compensate for the higher drag. However, because of the interaction of inlet drag, mission requirements and engine performance, a final selection must be by trial and error.

The term " 2100°R design" indicates that the ramjet is designed to operate at 2100°R at the design Mach number and altitude. During operation at other Mach numbers and altitudes the temperature may be much higher. In fact most of the climb and acceleration will be at the maximum permitted temperature in order to maximize thrust. As a " 2500°R design" would probably be permitted to operate at the same temperature limit, neither engine would be operating cooler. The " 2100°R design" would produce more thrust, however, due to the larger capture area.

DESIGN POINT SELECTION FOR MULTI-PURPOSE RAMJET

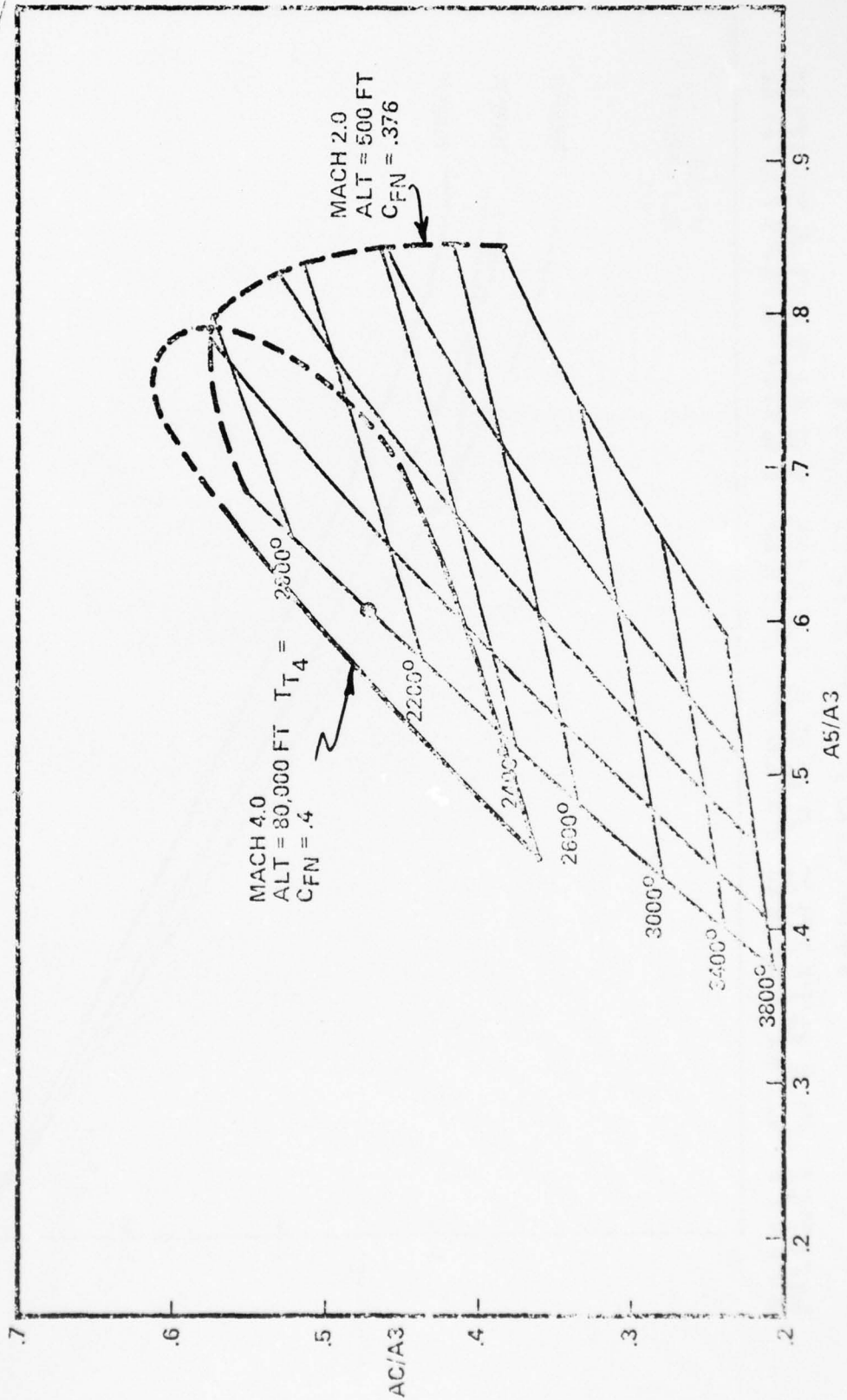

Figure 11

AD-A048 365

LTV AEROSPACE CORP DALLAS TEX VOUGHT SYSTEMS DIV
SEATIDE ANALYSIS PROCESS. VOLUME IIID. CRUISE MISSILE - CONCEPT--ETC(U)
JAN 74 G S MCCORKLE
VSD-00.1636-VOL-3D

F/G 15/7

DAAB09-72-C-0062

NL

UNCLASSIFIED

2 OF 2

ADA048365



END
DATE
FILMED
2-78
DDC

THRUST VARIATION WITH CAPTURE AREA AND TEMPERATURE

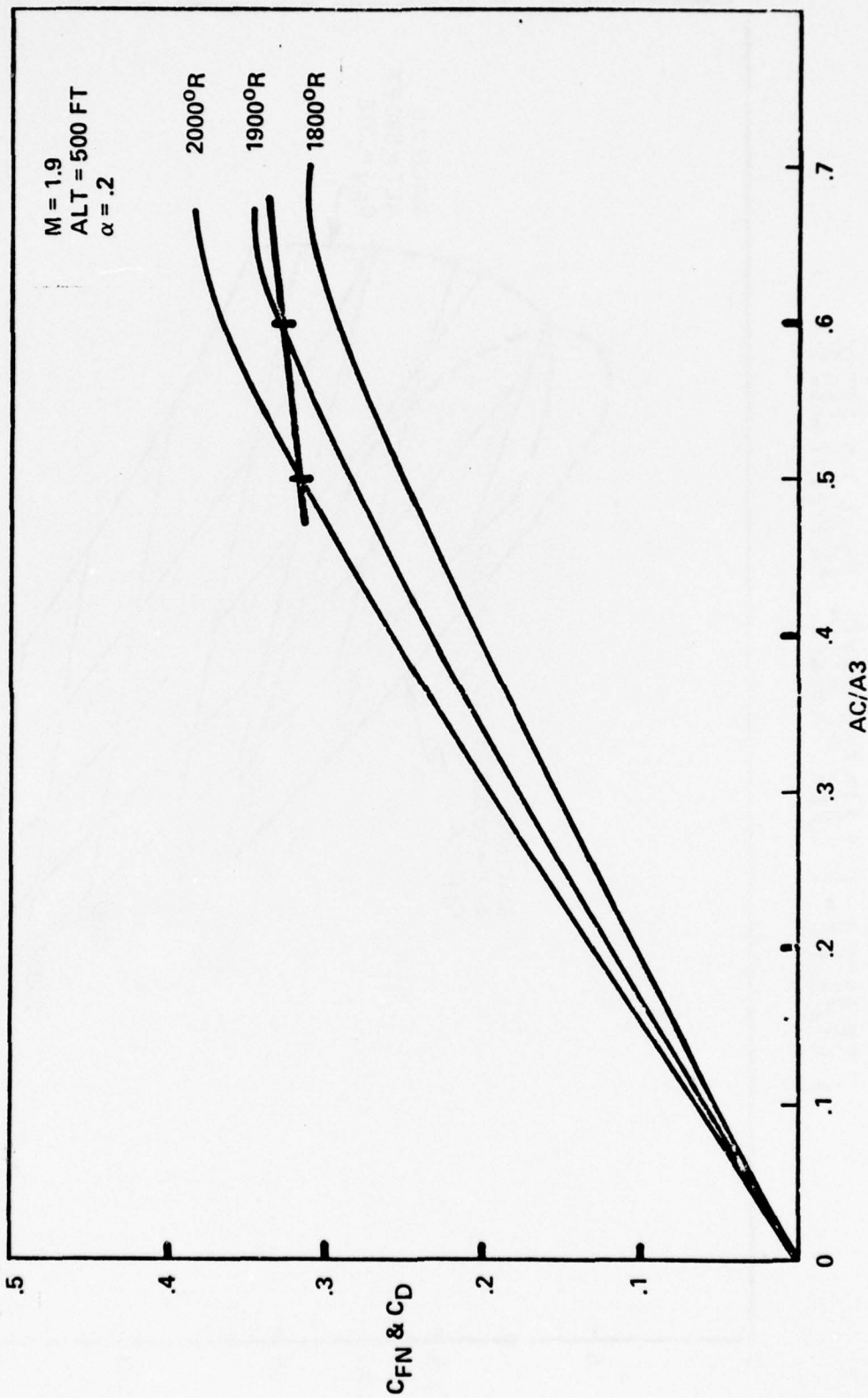

Figure 12

PERFORMANCE OF A MULTI-PURPOSE DESIGN

	DESIGN 1	DESIGN 2 (*)
T ₄ , OR	2100	2500
AC/A3	.47	.311
A5/A3	.60	.432

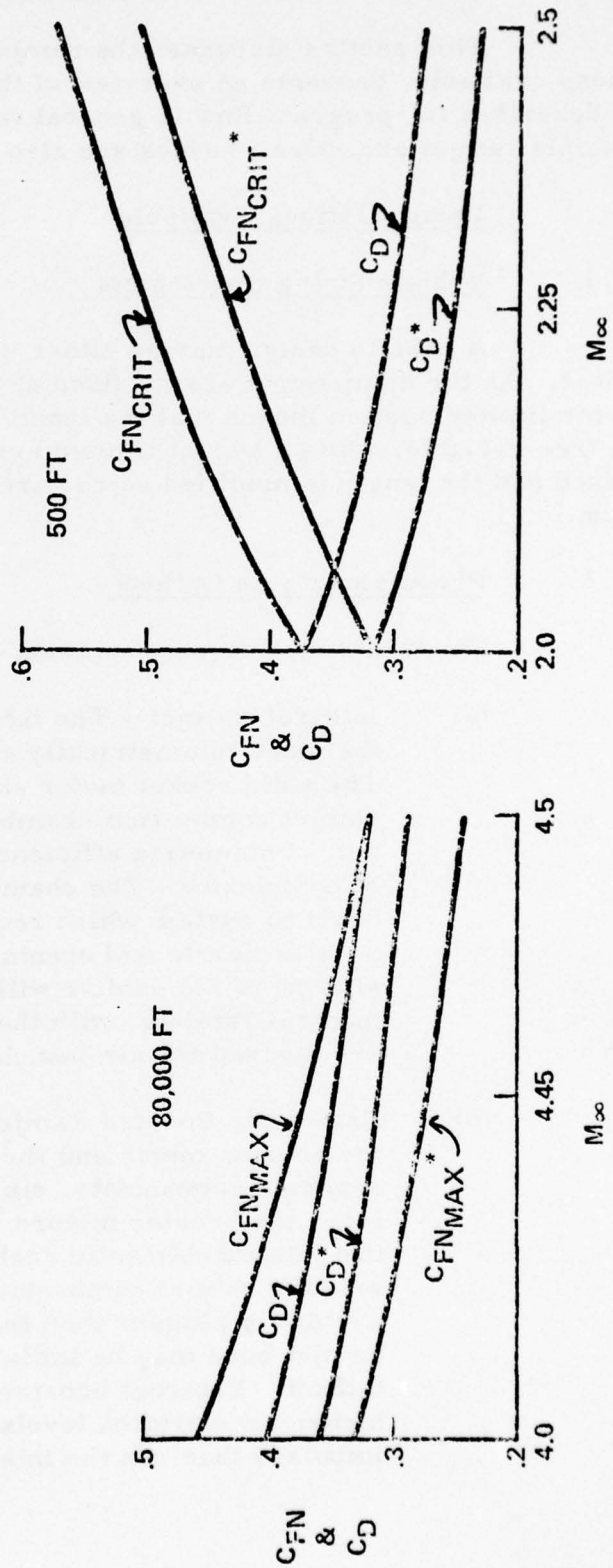

Figure 13

3.0 DESCRIPTION OF THE SEATIDE RAMJET PROPULSION MODEL

This section discusses the ramjet propulsion system design options available, presents an overview of the SEATIDE ramjet model, and describes the program flow in general terms. Flow charts of the two principle ramjet executive routines are also presented.

3.1 Design Options Available

3.1.1 Vehicle Sizing Constraints

A vehicle design may be either weight limited or volume limited. As the diameter is always fixed at the propulsion design level, volume limited system means that the length is specified and the weight is a free variable, while a weight limited system means that the weight is fixed and the length is modified as required to meet the weight specification.

3.1.2 Propulsion Cycle Options

The following ramjet propulsion system options are provided:

- (a) Integral Ramjet - The integral ramjet system provides the most volumetrically efficient ramjet configuration. The solid rocket motor chamber is utilized as the ramjet combustion chamber after booster motor burn-out. Volumetric efficiency is achieved at the expense of complexity. The chamber must transition from boost to sustain which requires jettisoning of the booster nozzle and opening of inlet ports. Some slowing of the vehicle will occur during transition. Integral ramjets, with their volumetric efficiency, are favored for air launched missiles.
- (b) Externally Boosted Ramjet - In design of this system, the booster motor and the ramjet combustor are separate components, since, in the SEATIDE methodology, the booster motors are assumed to consist of two jettisonable solid rocket motors mounted along side the ramjet combustor. Operationally, this system is simpler than the integral ramjet, since the ramjet burn may be initiated during booster motor tail off. External boosters can be designed with higher acceleration levels and can deliver larger ΔV impulses than can the integral booster. External

boosters find applications primarily in surface launched cruise missiles, where large ΔV is required and volume is not an overriding constraint.

- (c) Unboosted Ramjet - This is a pure ramjet system design. A supersonic airplane with a Mach 2.0 capability and provisions for submerged stores is required to accelerate this unboosted missile to its take-over Mach number.

3.1.2 Inlet Options

Inlet hardware design capability for both dual aft and belly mounted inlets have been included in the SEATIDE methodology. Performance for inlets designed at Mach 1.75, 2.0, 2.25 and 2.5 has been provided as separate input decks for both types of inlets (see Appendix C, Vol IIC). Selection between the two types of inlets is based primarily on packaging considerations.

3.1.3 Fuel Options

Three fuels which are in general use for ramjets and which may be input to the model (see Users Manual, Vol. IIIA) are:

- (a) JP5 - A standard hydrocarbon fuel; readily available and inexpensive.
- (b) HDHC - A high density hydrocarbon fuel with a considerable advantage over JP5 in volume limited situations.
- (c) Boron Slurry - An advanced fuel which will significantly out perform JP5 and HDHC; experimental with significant combustion efficiency problems; any combustion efficiency data on Boron Slurry will be controversial; very expensive fuel.

3.1.4 Material Options

Material options may be selected for each of the components by input of a material code in the proper location (see Users Manual, Vol. IIIA). Material properties available in the model include:

<u>Material</u>	<u>Code</u>
AISI 150 psi Steel	1
AISI 200 psi Steel	2
300 Gr Maraging Steel	3
17-4PH Stainless Steel	4
2014-T6 Aluminum	5
AZ31B-0 Magnesium	6
GAL-4V Titanium	7
RENE 41	8
WC 129Y Columbium	9
Glass Fabric Epoxy Laminate	10
Filament Wound Glass Epoxy	11

3.2 Ramjet Propulsion Methodology

3.2.1 Ramjet Design Processes Functional Flow

Design of any ramjet motor is necessarily an iterative process because of the interaction between the various components. For example, if additional thrust is required from a ramjet at a given combustion temperature, the inlet capture area must be increased. This increases vehicle drag and weight which in turn requires a larger booster. The larger booster will likely decrease the volume or weight available for the sustainer tank which will again result in a vehicle weight and/or length change. Consequently, the SEATIDE ramjet propulsion model utilizes a scheme of successive iterations in arriving at a final configuration. The main executive routine of the model is PROPXX (Figure 14) which manages design of integral ramjets, externally boosted ramjets, and unboosted ramjets.

3.2.2 Integral Ramjet Modeling

The first propulsion cycle to be considered will be the integral ramjet. When the design is initiated, only the payload weight and length are known. Initial starting values must be assumed for the thrust coefficient (CFN) required, sustainer (fuel tank and supporting hardware), size, angle of attack, and booster ideal velocity required. PROPXX makes an initial estimate of the sustainer size (weight or length depending on the vehicle constraint).

PROPXX next calls PROPRJ (Figure 15) which is the lower level executive routine. PROPRJ makes an initial estimate of the CFN required and determines the inlet performance of the design Mach number and estimated angle of attack. PROPRJ calculates a ramjet performance map which includes thrust coefficient (CFN), throat area ratio

(A5A3), exit area ratio (A6A3), and combustor pressure (PT4), all calculated for a series of capture area ratios (ACA3). Actual performance calculations are done by subroutine RJDES. The map is used then to determine the ramjet design at the required CFN. With the capture area thus determined, the inlet design and aerodynamics are established by calling INLETP, CDINLT, and INLIFT. Estimates of the weight and length of all components except the booster have now been established.

The booster is next designed by subroutine BOOST to produce the required ideal velocity change. At this point the sum of all weights (for a weight constrained vehicle) or the sum of all lengths (for a length constrained vehicle) will generally not equal the required value. An adjustment is then made to the sustainer size and the sustainer is redesigned. The booster must then be redesigned to produce its required velocity change for the new "payload" weight. This iteration is repeated as required until both the vehicle length/weight constraint and the booster velocity change requirements are met. If the vehicle is constrained and configured so that, after sizing all other components, insufficient length or weight is available for the sustainer, the configuration design effort is terminated.

After convergence on the correct booster/sustainer split, PROPRJ proceeds to check the ramjet design extracted from the ramjet map by once again calling RJDES and determining the actual geometry necessary to produce the CFN required. PROPRJ then returns control to PROPXX. The routine has now calculated a ramjet design based on an assumed CFN required and angle of attack. Subroutine XALPHA computes actual drag, lift, angle of attack, and CFN required. PROPXX now iterates between XALPHA and PROPRJ until the correct CFN is obtained from a correctly sized vehicle. In this iteration the process described in PROPRJ above is repeated as required except that:

- (a) The initializations are not repeated.
- (b) The ramjet map is not recalculated if the angle of attack does not vary (within one degree)
- (c) The booster is sized by use of partial differentials if the ramjet nozzle throat area ratio does not vary (within 0.1).

It is possible that the ramjet will be unable to develop the required CFN at the input combustion temperature. If this happens, the routine will check to see if it is permitted to increase the combustion temperature. If no temperature change is permitted, or if the maximum

value has already been reached, the configuration design effort is terminated. Otherwise, the combustion temperature is incremented and the design continues.

Subroutine BOOST has sized to an ideal velocity requirement. Because the vehicle drag was not exactly known, the actual velocity delivered can be expected to be incorrect. Therefore, a final iteration must be made in order to produce the velocity change required.

After completing the design, PROPXX will make a final pass through the various hardware routines in order to calculate the moment of inertia and center of gravity of each of the components. These properties are not calculated previously in order to reduce computation time. The final pass through the design process also permits detail output of each component configuration if desired.

3.2.3 Externally Boosted Ramjet Modeling

The externally boosted ramjet design flow is similar to that of the integral ramjet, except overall vehicle length includes a ramjet combustor rather than a booster. Boost to ramjet take-over velocity is accomplished by one or two strap-on solid motors. These motors affect vehicle weight but not length.

3.2.4 Unboosted Ramjet Modeling

The unboosted ramjet design flow is similar to the externally boosted ramjet except for the absence of a booster.

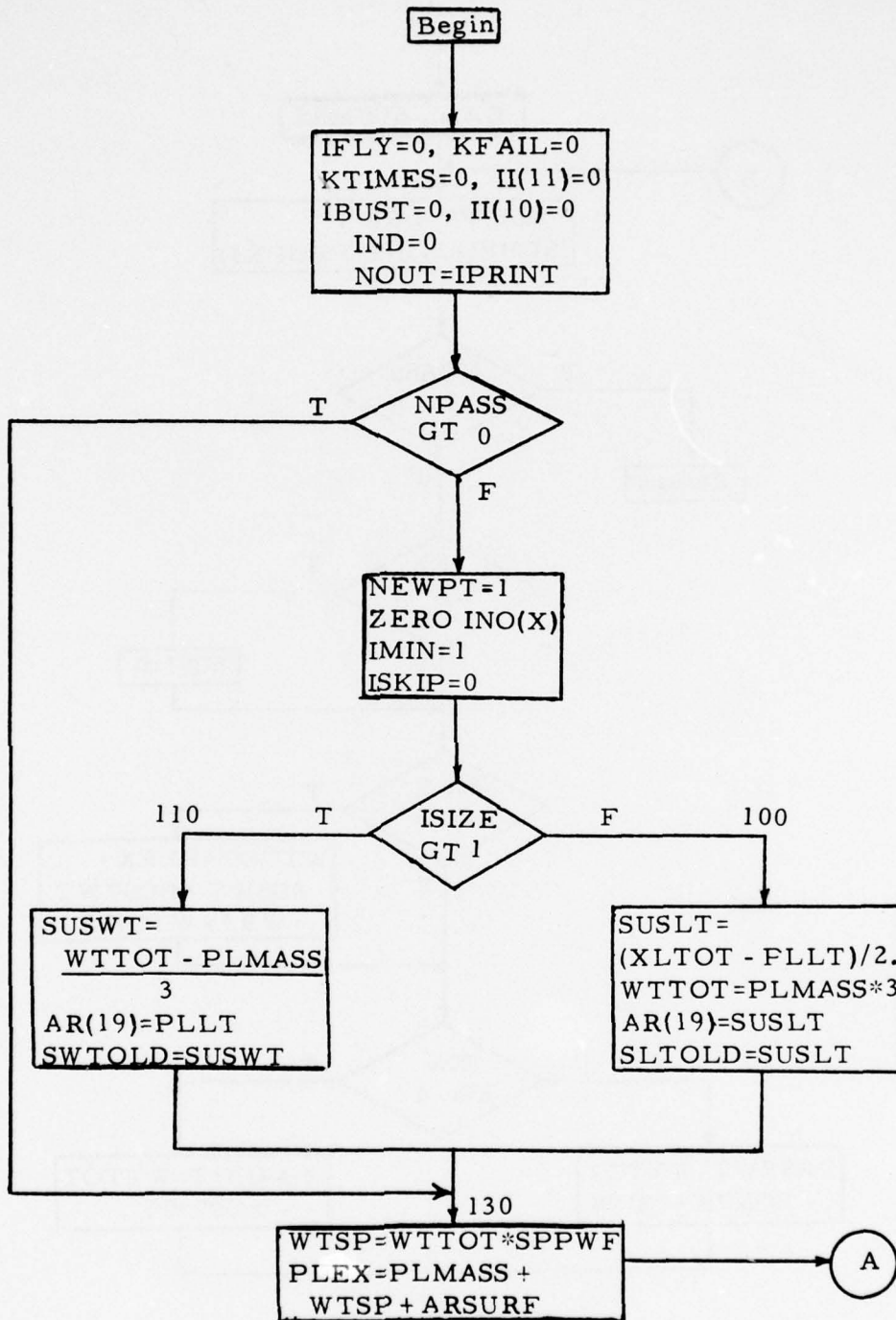

FIGURE 14
RAMJET PROPULSION MODEL LOGIC FLOW
SUBROUTINE PROPPX

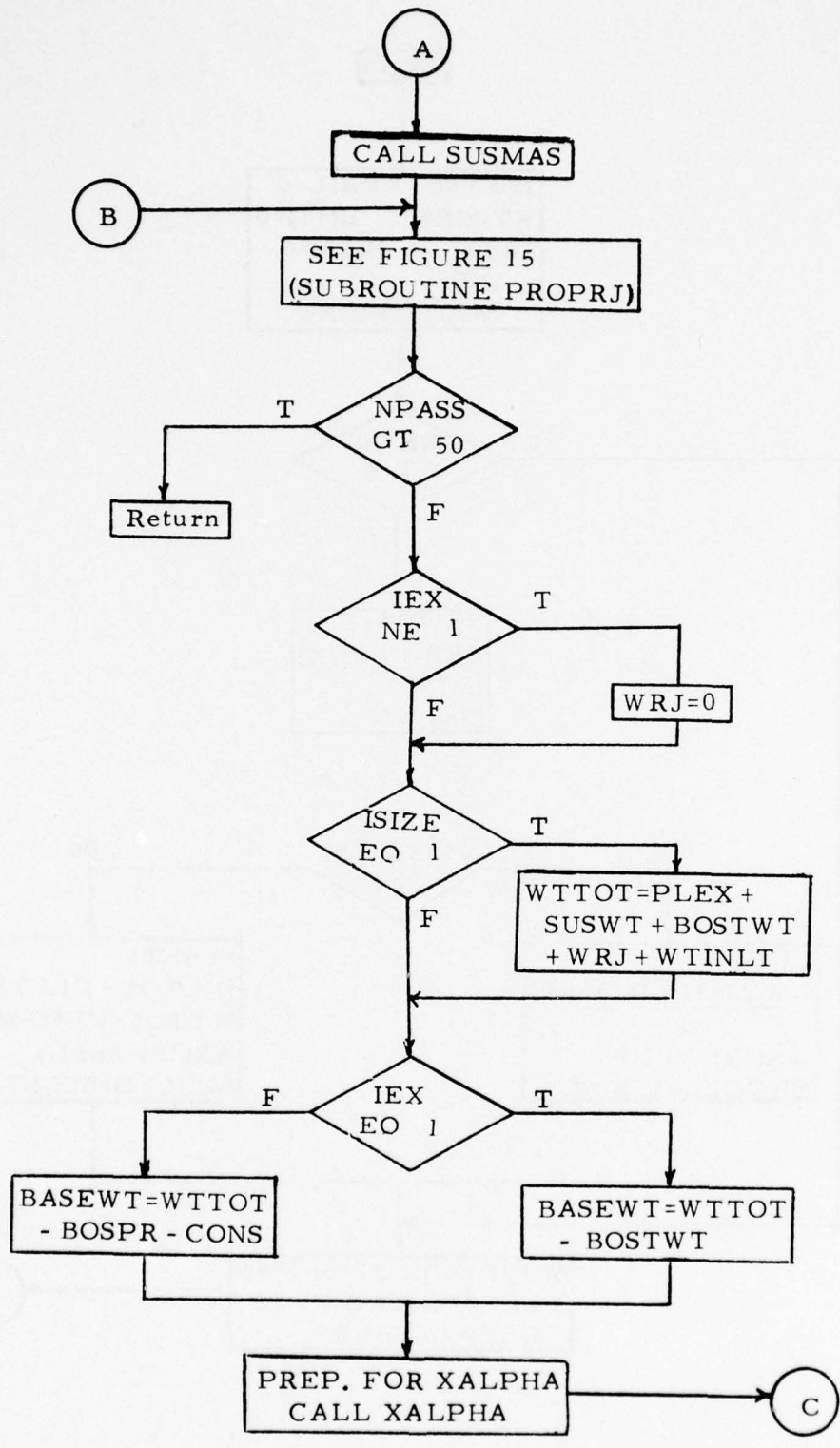

Figure 14 (Continued)

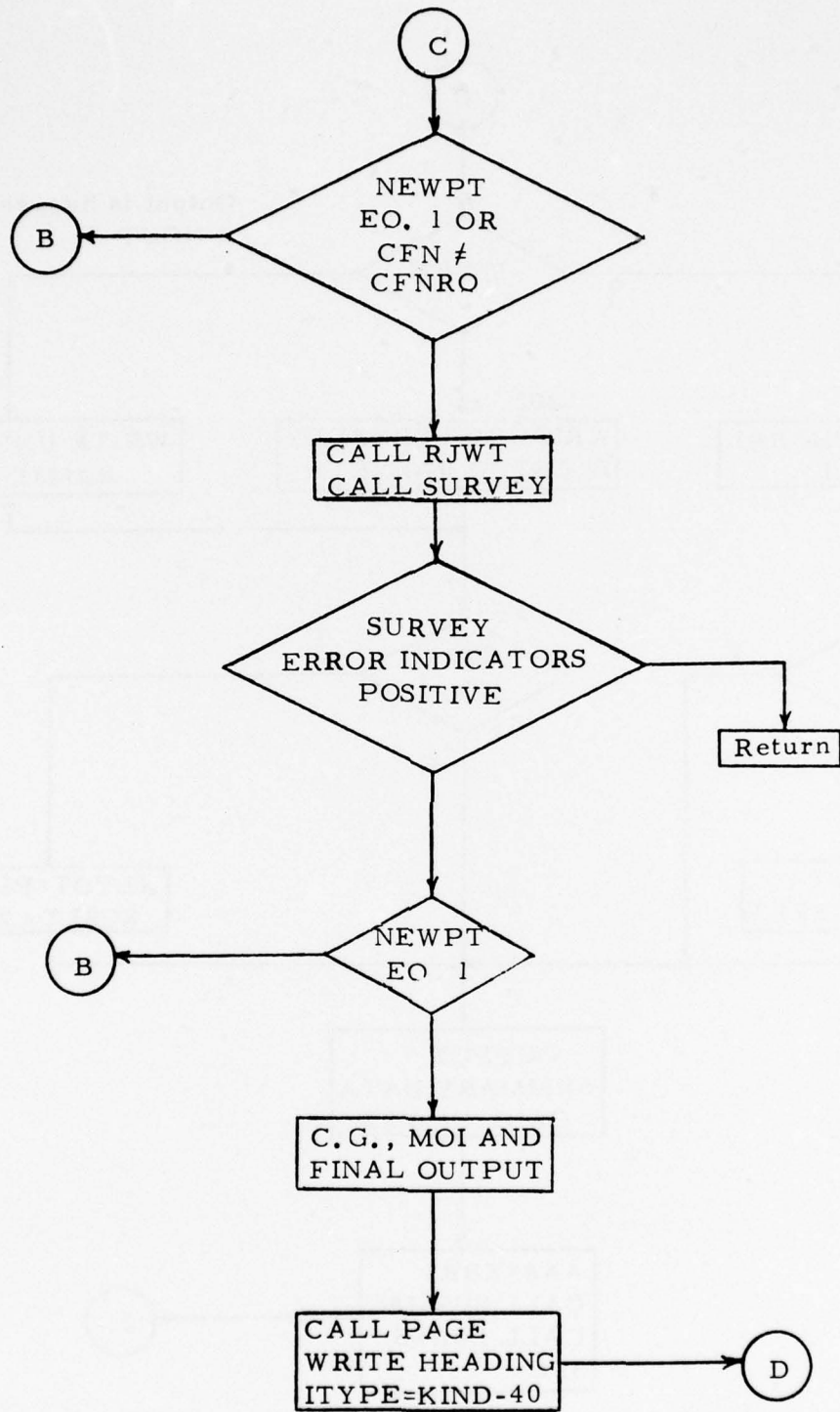

Figure 14 (Continued)

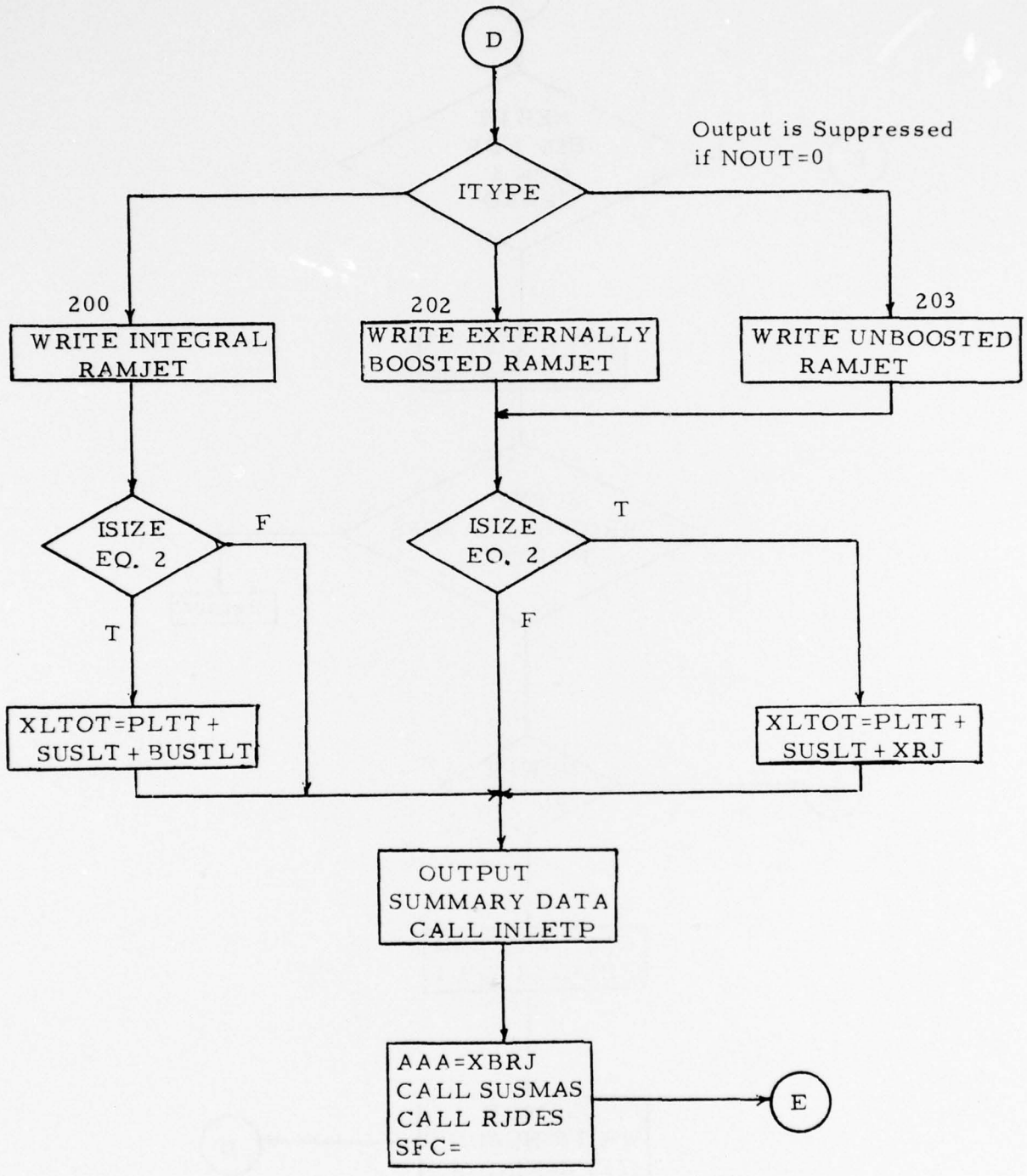

Figure 14 (Continued)

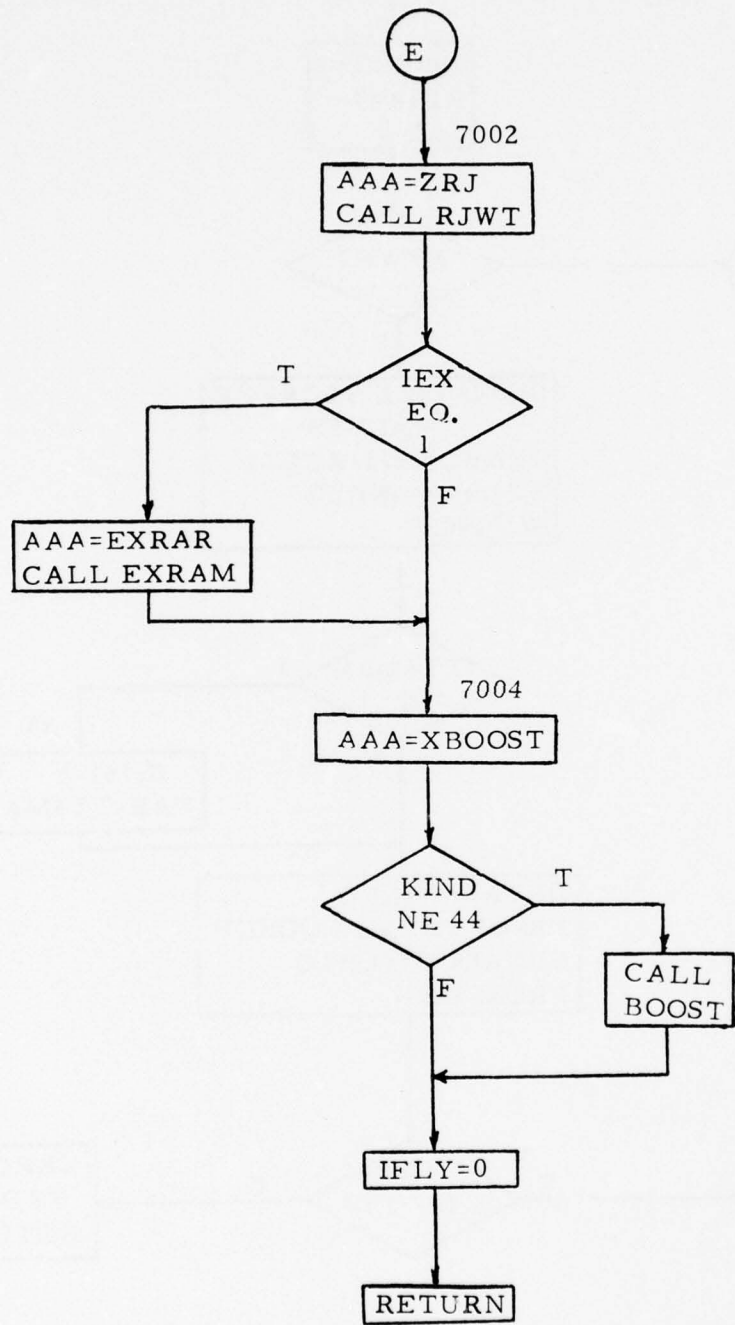

Figure 14 (Continued)

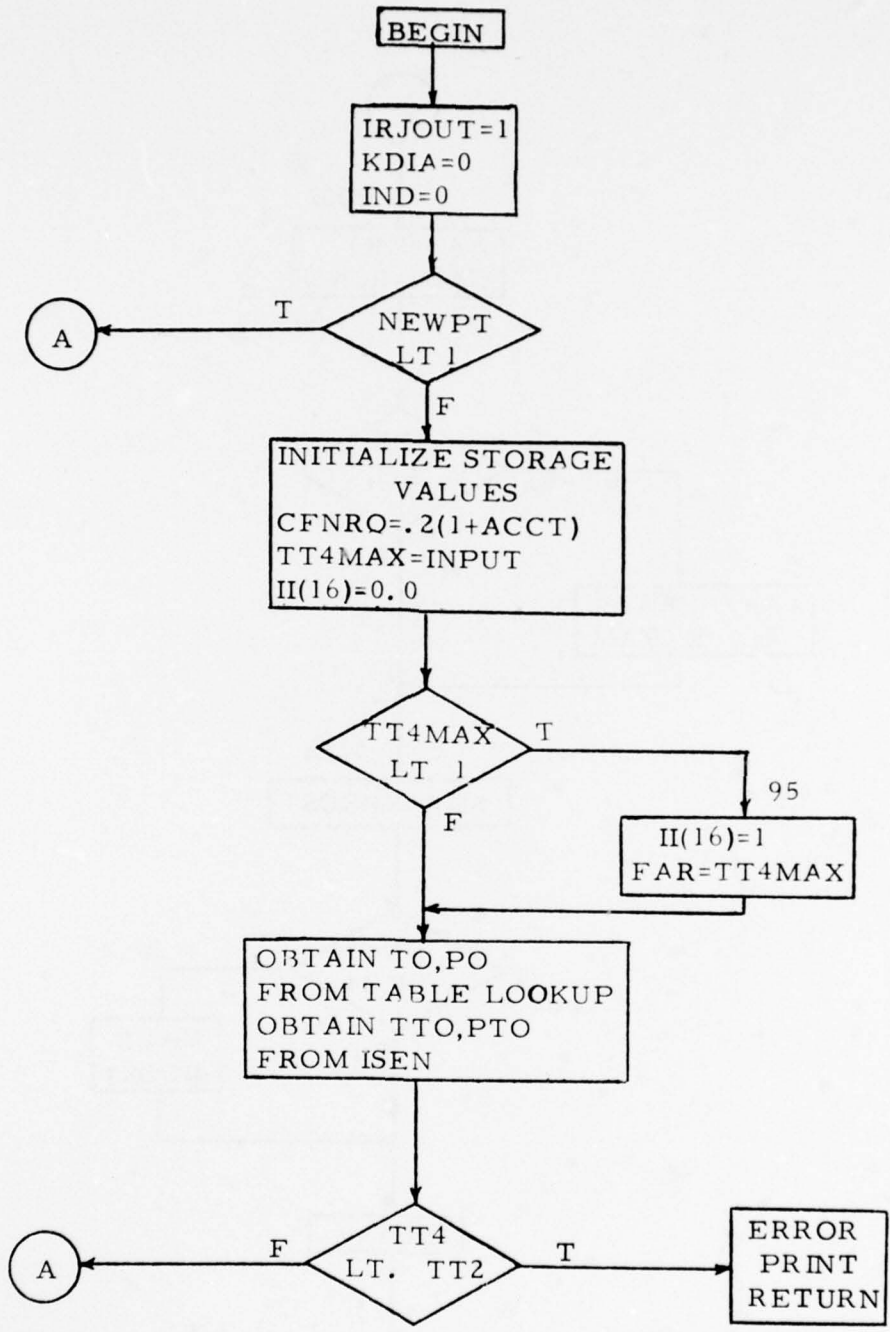

FIGURE 15
 RAMJET PROPULSION MODEL LOGIC FLOW
 SUBROUTINE PROPRJ

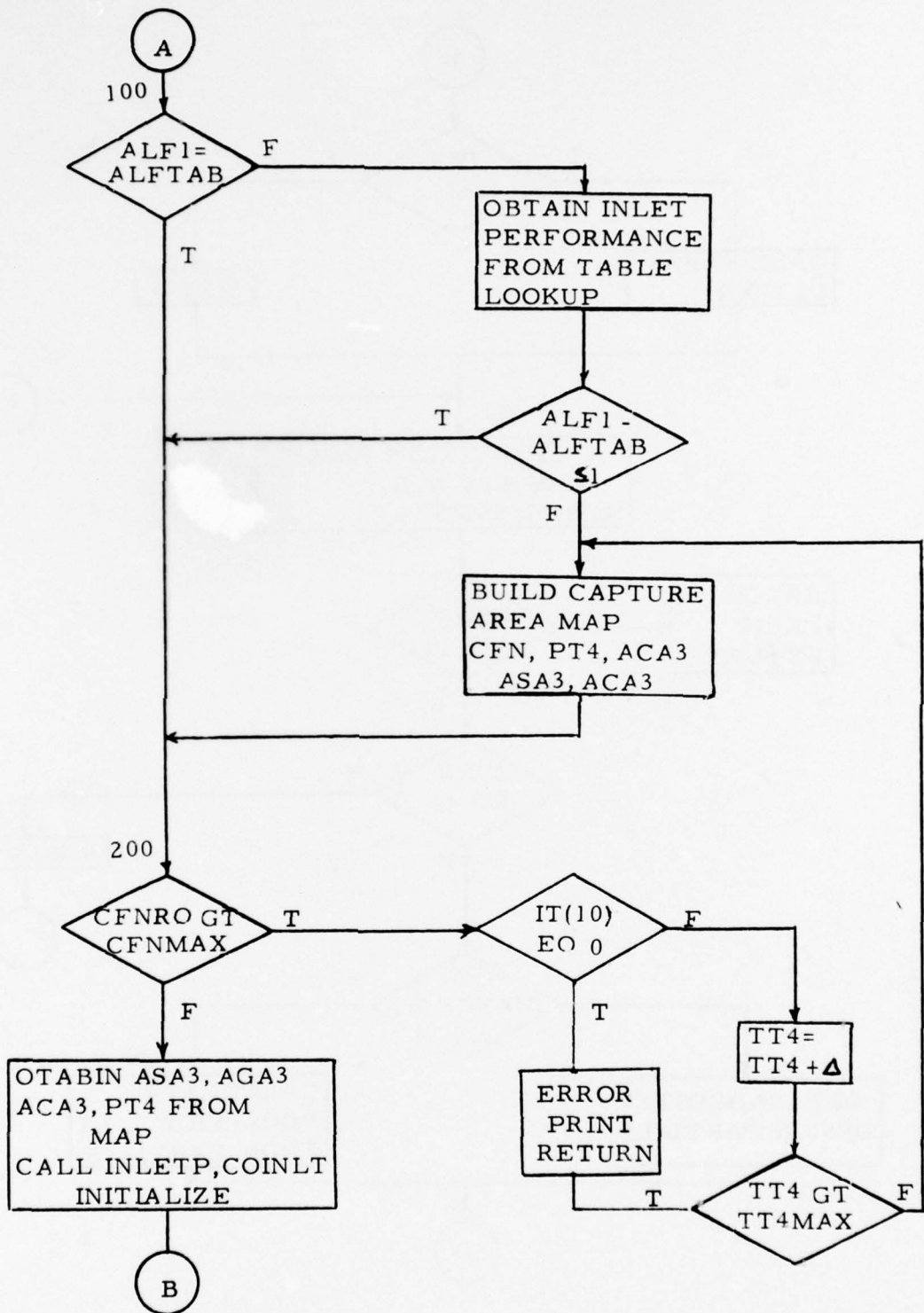

Figure 15 (Continued)

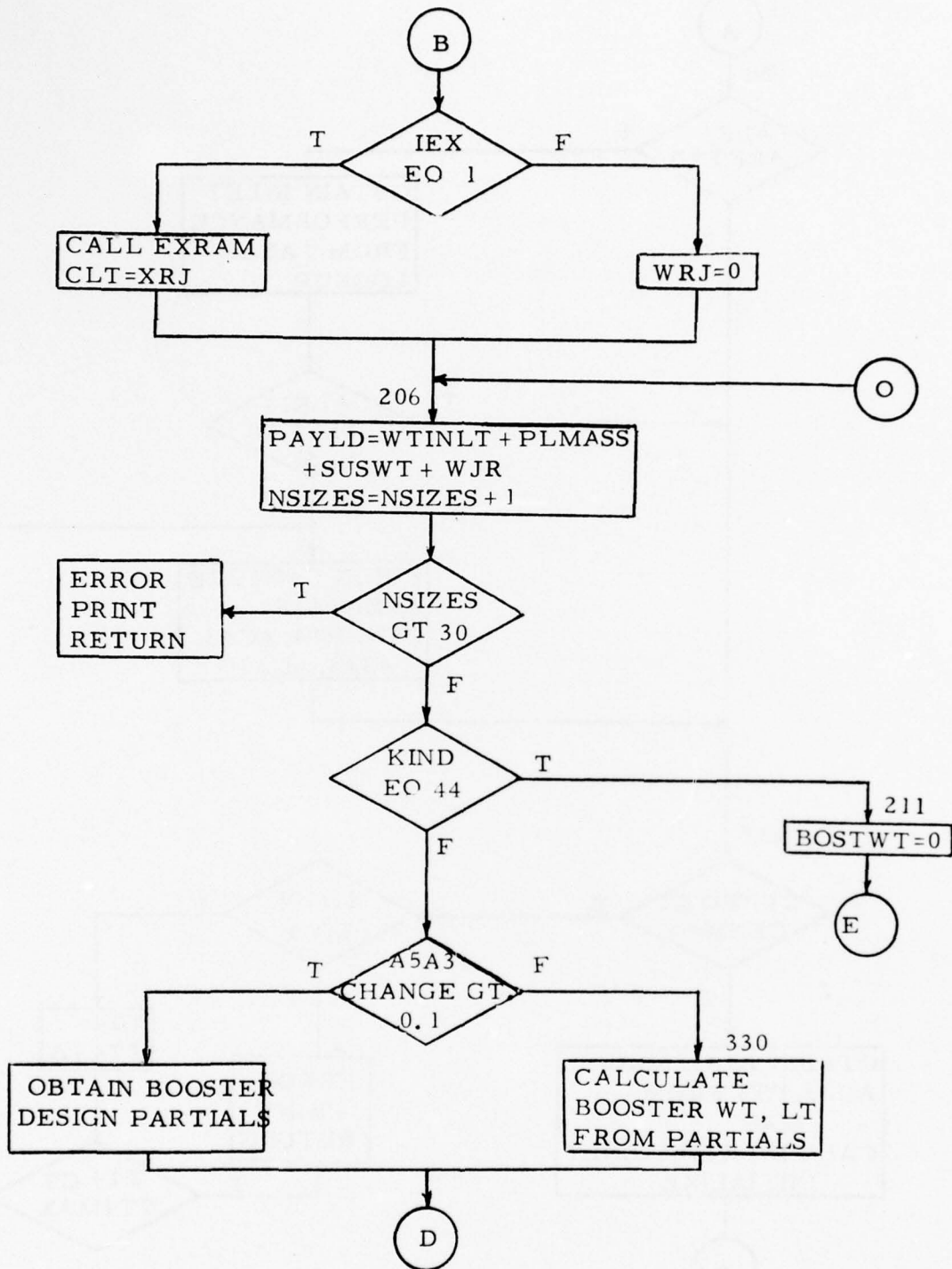

Figure 15 (Continued)

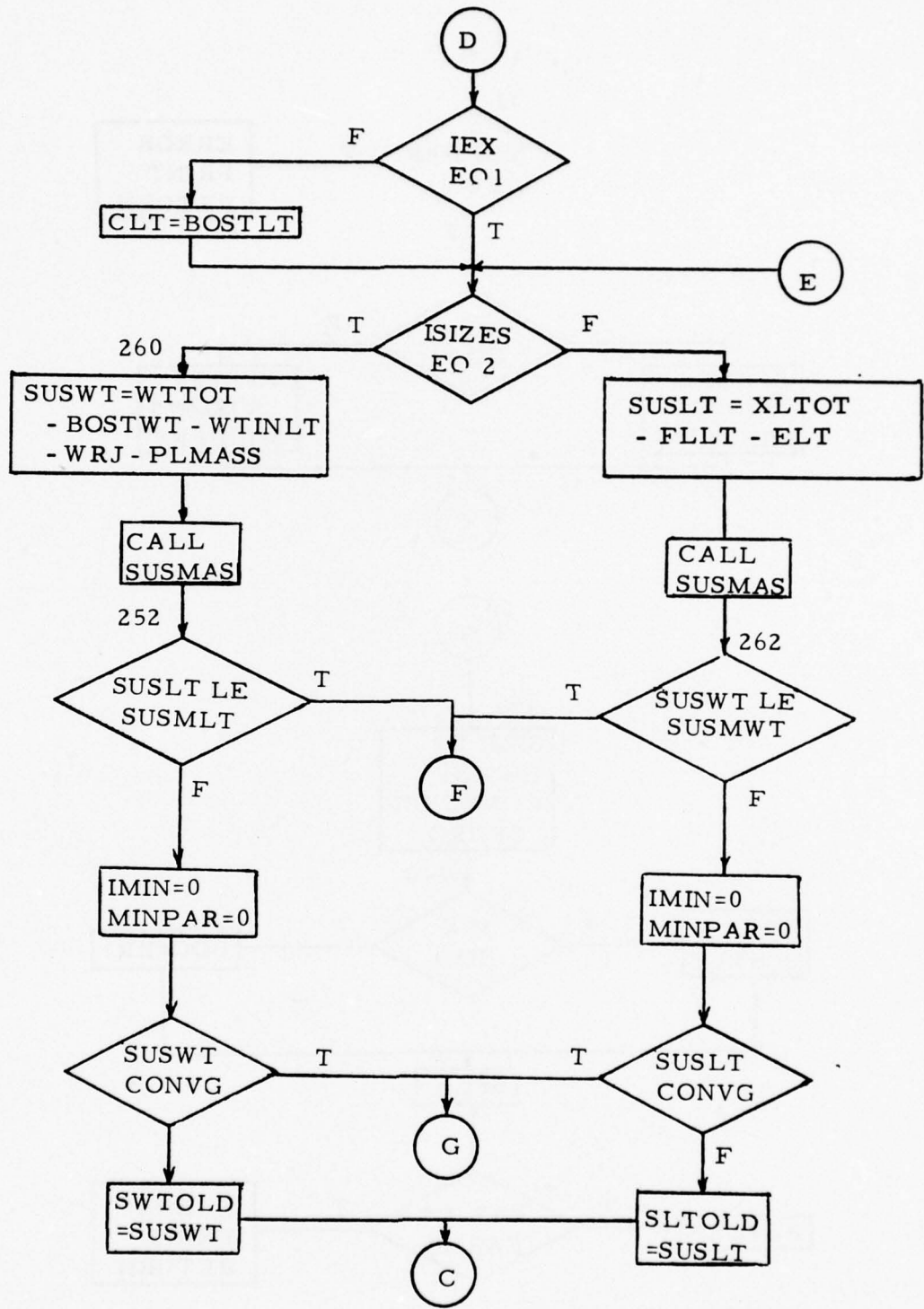

Figure 15 (Continued)

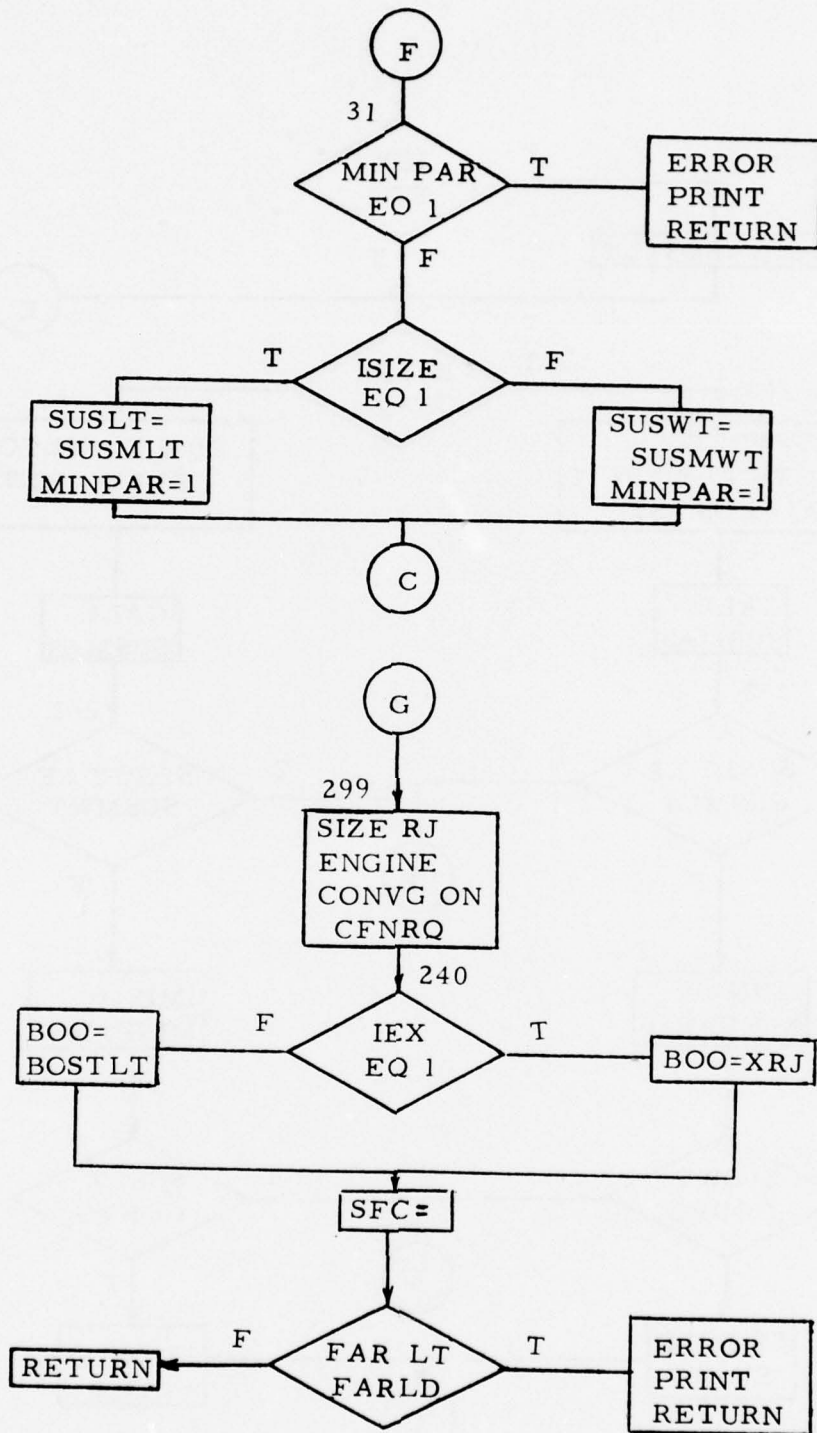

Figure 15 (Continued)

4.0 TECHNICAL DESCRIPTION AND MATH MODELS

This section discusses key individual subroutines which size and design the propulsion system components in the vehicle. Equations are presented in sufficient detail to permit the user to understand the math model used.

4.1 Ramjet Vehicle Synthesis

4.1.1 Starting Values

Section 3.2.1 discusses the need for initial starting values to permit the iteration schemes to function. These values are of a transient nature only. They affect the initial configuration and the efficiency of the iteration, but not the final configuration.

(a) Weight Constrained Vehicle

$$\text{SUSWT} = (\text{WTTOT} - \text{PLMASS})/3$$

$$\text{Booster length} = \text{PLLT}$$

(b) Length Constrained Vehicle

$$\text{SUSLT} = (\text{XLTOT} - \text{PLLT})/2$$

$$\text{WTTOT} = \text{PLMASS} * 3$$

$$\text{Booster length} = \text{SUSLT}$$

where SUSWT = sustainer length

WTTOT = total vehicle weight

PLMASS = payload weight

PLLT = payload length

SUSLT = sustainer length

XLTOT = total vehicle length

4.1.2 Propulsion System Payload

From a propulsion system viewpoint, the payload includes all components which are not directly a part of the propulsion system.

$$WTSP = WTTOT * SPPWF$$

$$PLEX = PLMASS + WTSP + ARSURF$$

where:

WTSP = weight of secondary power package

SPPWF = weight fraction of secondary power package

PLEX = weight of propulsion system payload

ARSURF = weight of aerodynamic surfaces

WTTOT = total vehicle weight

PLMASS = payload weight

4.1.3 Final Vehicle Synthesis

As discussed in Section 3.1.2, final sizing of the vehicle consists of assigning the remainder of the length or the weight left over after everything else has been sized to the sustainer tank. Because of this, the propulsion executive routines must keep track of all component weights. Vehicle synthesis takes place in the propulsion executive routines as follows:

(a) Weight Constrained Vehicle

Vehicle weight is

$$SUSWT = WTTOT - BOSTWT - WTINLT - WRJ - PLEX$$

Vehicle length is

$$XLTOT = PLLT + SUSLT + BOSTLT \quad \text{Integral Ramjet}$$

$$XLTOT = PLLT + SUSLT + XRJ \quad \text{Non-Integral Ramjet}$$

(b) Length Constrained Vehicle

Vehicle length is

$$SUSLT = XLTOT - PLLT - CLT$$

where:

$CLT = BOSTLT$ Integral Ramjet
 $CLT = XRJ$ Non-Integral Ramjet

Vehicle weight is

$$WTTOT = PLEX + SUSWT + BOSTWT + WRJ + WTINLT$$

$WRJ=0$ Integral Ramjet
 $BOSTWT=0$ Unboosted Ramjet

where:

$SUSWT$ = sustainer weight
 $WTTOT$ = Vehicle total length
 $BOSTWT$ = Booster weight
 $WTINLT$ = Inlet weight
 WRJ = Ramjet combustor weight
 $PLEX$ = Propulsion payload weight
 $PLLT$ = Payload length
 $SUSLT$ = Sustainer length
 $BOSTLT$ = Booster length
 XRJ = Ramjet combustor length

4.1.4 Weight After Transition

After transition from boost to ramjet operation, the vehicle will have the following weights:

(a) Integral Ramjet

$$BASEWT = WTTOT - BOSPR - CONS$$

(b) Non-Integral Ramjet

$$BASEWT = WTTOT - BOSTWT$$

where

$BASEWT$ = Vehicle weight after transition
 $BOSPR$ = Booster propellant weight
 $CONS$ = Booster inerts consumed weight
 $BOSTWT$ = Booster weight
 $WTTOT$ = Total vehicle weight

4.2 Ramjet Sizing and Performance Modules

Calculation of the ramjet area ratios (capture area, nozzle area and exit area relative to combustor area) and performance at the design point are calculated by subroutines PROPRJ and RJDES. RJDES determines the area ratios necessary to give a required thrust level. Performance (once the configuration is known) for trajectory simulations is handled by subroutine PROPI. Ramjet lengths and weights are not calculated in these routines as they are assumed to have no direct impact on ramjet performance. Calculation of these parameters is discussed in Section 4.3 of this appendix.

A derivation of the basic equations used for ramjet design and off-design performance is presented in this section. The equations are based on the one-dimensional compressible flow laws of gas dynamics and thermodynamics. Where possible, coefficients and efficiencies have been introduced into the analyses in order that deviations from ideal flow processes may be accounted for. The nomenclature used in the equations is attached, and a schematic diagram of the ramjet with station designations is presented in Figure 16.

The equations which govern the propulsion performance of a ramjet engine are obtained in their most general form when one seeks the off-design performance of a given engine. Therefore, the equations which apply to the determination of the off-design propulsion performance of a ramjet (subroutine PROPI) will be derived first.

4.2.1 Basic Thrust Equations

The most general form of the net thrust equation for a ramjet is obtained for a ramjet which is pylon mounted to a missile (Figure 16). The net thrust of such a ramjet is defined as the thrust produced within the engine minus the drag forces acting on the external engine surfaces

$$F_N = F_{INT} - D_{EXT}$$

Symbol definitions are in Table V on page F-96.

Thrust produced within the ramjet engine is called gross thrust. It is defined as the difference between the values of the stream thrusts for the flow passing through the engine less the product of the ambient pressure P_o times the difference between the cross-sectional areas A_6 and A_o .

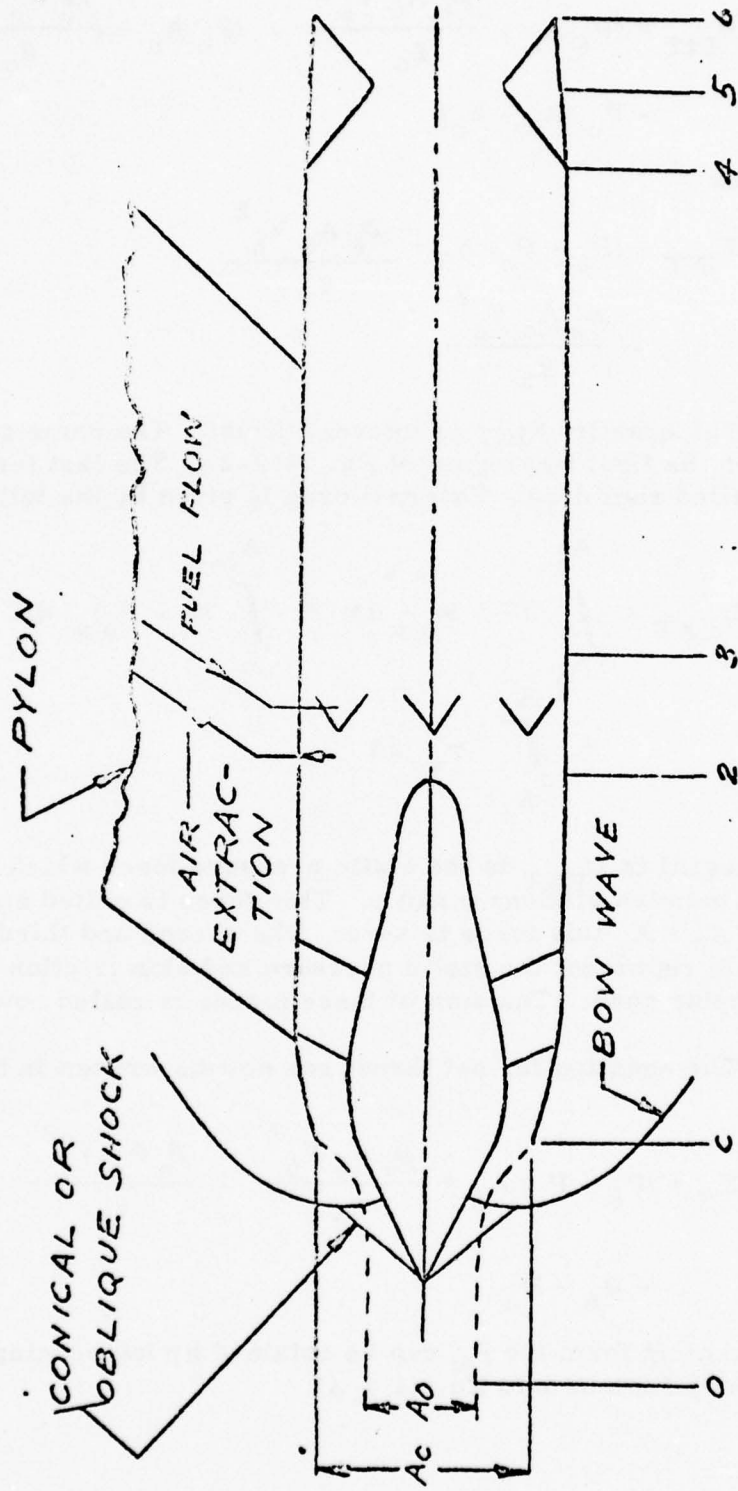

F-45

Figure 16 Schematic Diagram of a Ramjet Propulsion System

Hence

$$F_{\text{INT}} = (P_6 A_6 + \frac{\rho_6 A_6 V_6^2}{g_0}) - (P_o A_o + \frac{\rho_o A_o V_o^2}{g_0}) - P_o (A_6 - A_o) \quad (4.2-1)$$

or

$$F_{\text{INT}} = (P_6 - P_o) A_6 + \frac{\rho_6 A_6 V_6^2}{g_0} - \frac{\rho_o A_o V_o^2}{g_0} \quad (4.2-2)$$

The quantity F_{INT} is internal thrust. The name gross thrust is used here for the first two terms of Eq. (4.2-2). The last term of Eq. (4.2-2) is called ram drag. External drag is given by the following equation.

$$D_{\text{EXT}} = \int_{A_o}^{A_c} (P - P_o)_x dA + \int_{A_c}^{A_6} (P - P_o)_x dA + \int_{A_c}^{A_6} \tau_x dA \quad (4.2-3)$$

The first integral in D_{EXT} is the static pressure force which acts on the stream tube between stations o and c . This force is called additive drag (D_A). When $A_o = A_c$ this force is zero. The second and third integrals of Eq. (4.2-3) represent the static pressure and skin friction forces which act on the engine cowl. The sum of these forces is called cowl drag (D_c).

The equation for net thrust can now be written in the following form.

$$F_N = (P_6 - P_o) A_6 + \frac{\rho_6 A_6 V_6^2}{g_0} - \frac{\rho_o A_o V_o^2}{g_0} - D_A - D_c \quad (4.2-4)$$

A more convenient form for F_N can be obtained by introducing the following equations and definitions into Eq. (4.2-4).

$$\rho_o = \frac{P_o}{R_o T_o} \quad (4.2-5)$$

$$C_o = \sqrt{\gamma_o g_o R T_o} \quad (4.2-6)$$

$$M = V/C \quad (4.2-7)$$

$$D_A = C_{DA} \frac{\rho_o A_c V_o^2}{2 g_o} \quad (4.2-8)$$

$$D_C = C_{DC} \frac{\rho_o A_3 V_o^2}{2 g_o} \quad (4.2-9)$$

$$ST_6 = \frac{\rho_6 A_6 V_6^2}{g_o} + P_6 A_6 \quad (4.2-10)$$

The resultant thrust equation then becomes

$$F_N = ST_6 - P_o A_6 - \gamma_o P_o A_o M_o^2 - \frac{(C_{DA})}{2} A_c \gamma_o P_o M_o^2 \quad (4.2-11)$$

4.2.2 Data Required for Off-Design Analysis

The following data are required to compute off-design performance:

- (a) Mach number (M_o), the flight altitude (ALT), the type of day and the angle of attack of the missile inlet with respect to the free stream (α).
- (b) The flow areas of the engine (A_c, A_2, A_3, A_4, A_5 and A_6) and the engine cowl shape.
- (c) The engine inlet performance maps.
- (d) The combustion chamber burner drag coefficient (C_{DB}).
- (e) The chemical composition of the fuel.
- (f) The bleed fraction.
- (g) The nozzle mass flow coefficient C_{NM} and the nozzle stream thrust efficiency η_N .
- (h) The temperature rise combustion efficiency expected.

4.2.3 Internal Gas Flow Analysis

The internal gas flow analysis is divided into three sections corresponding to the inlet, the combustor, and the nozzle of the engine.

4.2.3.1 Inlet Performance

For supercritical performance, the mass flow entering the engine is a maximum for the given freestream Mach number. That is

$$W_{\max} = \rho_o V_o A_o \max \quad (4.2-12)$$

For subcritical performance the airflow into the inlet is reduced by air spillage which occurs when the normal shock is positioned ahead of the inlet cowl lip. The intersection of the subcritical and supercritical portions of the P_{T_2}/P_{T_o} curve represents the critical operation point of the inlet. It is noted that when the inlet operates critically or supercritically, the additive drag coefficient is a minimum. When the engine operates critically or supercritically at or beyond the inlet design Mach number, the conical shock is completely swallowed. For this case the additive drag coefficient is equal to zero.

Some additional relations and assumptions which will be useful for matching the engine inlet to the combustor are the following:

- (a) The mass flow into the engine inlet is equal to the mass flow at the diffuser exit.

$$W_A = \rho_o A_o V_o = \rho_2 A_2 V_2 \quad (4.2-13)$$

- (b) The relationship of the static to the stagnation fluid properties of the freestream is assumed to be the following:

$$\frac{P_{T_o}}{P_o} = \left[\frac{T_{T_o}}{T_o} \right]^{\gamma_o/(\gamma_o-1)} = \left[1 + \frac{\gamma_o - 1}{2} M_o^2 \right]^{\gamma_o/(\gamma_o-1)} \quad (4.2-14)$$

where γ_o is taken to be 1.4

- (c) The stagnation temperature at the diffuser exit is assumed to be equal to the stagnation temperature of the free stream.

$$T_{T_2} = T_{T_0} \quad (4.2-15)$$

- (d) The equation of state and the equation for the speed of sound of the air leaving the diffuser exit are given by the following equations.

$$P_2 = \rho_2 R_2 T_2 \quad (4.2-16)$$

$$C_2 = \sqrt{\gamma_2 g_0 R_2 T_2} \quad (4.2-17)$$

where γ_2 and R_2 are determined from input fuel properties.

- (e) The relationships of the static to the stagnation fluid properties of the air leaving the diffuser exit are assumed to be the following:

$$\begin{aligned} \frac{P_{T_2}}{P_2} &= \left[\frac{T_{T_2}}{T_2} \right]^{\gamma_2 / (\gamma_2 - 1.)} \\ &= \left[1. + \frac{\gamma_2 - 1}{2} M_2^2 \right]^{\gamma_2 / (\gamma_2 - 1.)} \end{aligned} \quad (4.2-18)$$

All of the relations along Eqs. (4.2-5), (4.2-6), and (4.2-7) can be combined into a single equation by substituting Eqs. (4.2-5), (4.2-6), (4.2-7) and Eqs. (4.2-14) through (4.2-18) into Eq. (4.2-13). The end result is

$$\left[\frac{A_o}{A_c} \right] = \sqrt{\frac{\gamma_2 R_o}{\gamma_o R_2}} \frac{M_2}{M_o} \frac{(P_{T_2}/P_{T_o})}{\frac{(A_c)}{(A_3)}} \frac{\left[1. + \frac{\gamma_o - 1}{2} M_o^2 \right]^{(\gamma_o + 1)/(2.(\gamma_o - 1.))}}{\left[1. + \frac{\gamma_2 - 1}{2} M_2^2 \right]^{(\gamma_2 + 1.)/(2.(\gamma_2 - 1))}} \quad (4.2-19)$$

For T_{T_2} less than $4000^\circ R$ the gas constants R_2 and R_o are assumed to be equal. Hence, it is possible to eliminate them from Eq. (4.2-19) for the practical range of T_{T_2} expected for a ramjet.

4.2.3.2 Engine Combustor Performance

The equations which govern the thermal flow processes are the following.

Conversion of Mass

$$W_A (1 - l) + W_p = W_4 \quad (4.2-20)$$

$$\rho_2 A_3 V_2 (1 - l) + (f/a) \rho_2 A_3 V_2 (1 - l) = \rho_4 A_4 V_4$$

Equations of State

$$\rho_2 = \frac{P_2}{R_2 T_2}, \quad \rho_4 = \frac{P_4}{R_4 T_4} \quad (4.2-21)$$

Stagnation to static fluid property relations

$$\frac{P_{T2}}{P_2} = \left[\frac{T_{T2}}{T_2} \right]^{\gamma_2 / (\gamma_2 - 1)} = \left[1 + \frac{\gamma_2 - 1}{2} M_2^2 \right]^{\gamma_2 / (\gamma_2 - 1)}$$

$$H_{T4} = H_4 + \frac{V_4^2}{2 g_o J} \quad (4.2-22)$$

Conservation of Momentum

$$P_2 A_3 + \frac{\rho_2 A_3 V_2^2}{g_o} - B = P_4 A_3 + \frac{\rho_4 A_3 V_4^2}{g_o} \quad (4.2-23)$$

Burner drag coefficient definition

$$C_{DB} = \frac{B}{\frac{\rho_2 A_3 V_2^2}{2 g_o}} \quad (4.2-24)$$

The combustion efficiency is an input tabular function of the burner severity parameter

$$\eta_c = f(B_{SP}) \quad \text{where } B_{SP} = \frac{W_A}{A_5} \left\{ \frac{T_{T_o}}{1000} \right\}^2 \quad (4.2-25)$$

Temperature rise is determined from:

$$\Delta T_{\text{actual}} = (\Delta T_{\text{ideal}}) \eta_c \quad (4.2-26)$$

The final step in the solution of the combustor flow equations requires some reduction of equations (4.2-20) through (4.2-24) to a fewer number of equations. This process is facilitated if one assumes that the ratio of specific heats of the combustion products does not change as they are expanded isentropically from their stagnation state. This assumption allows one to write the following equations.

$$C_4 = \sqrt{\gamma_4 g_o R_4 T_4} \quad (4.2-27)$$

$$\frac{P_{T_4}}{P_4} = \left[\frac{T_{T_4}}{T_4} \right]^{\gamma_4 / (\gamma_4 - 1)} = \left[1. - \frac{\gamma_4 - 1}{2} M_4^2 \right]^{\gamma_4 / (\gamma_4 - 1)} \quad (4.2-28)$$

One can now reduce the number of equations to be solved by substituting Eqs. (4.2-21), (4.2-7), (4.2-17), (4.2-27), (4.2-22), (4.2-28) into Equation (4.2-22) to obtain

$$\frac{P_{T_2}}{\sqrt{T_{T_2}}} \sqrt{\frac{\gamma_2 g_o}{R_2}} \frac{M_2 (1 + f/a) (1 - \ell)}{\left[1. + \frac{\gamma_2 - 1}{2} M_2^2 \right]^{(\gamma_2 + 1) / (2(\gamma_2 - 1))}} = \quad (4.2-29)$$

$$\frac{P_{T_4}}{\sqrt{T_{T_4}}} \sqrt{\frac{\gamma_4 g_o}{R_4}} \frac{M_4}{\left[1. + \frac{\gamma_4 - 1}{2} M_4^2 \right]^{(\gamma_4 + 1) / (2(\gamma_4 - 1))}}$$

and Eqs. (4.2-24), (4.2-21), (4.2-7), (4.2-27), (4.2-22), (4.2-28) into Equation (4.2-23) to obtain

$$\frac{P_{T2} (1 + \gamma_2 M_2^2)}{\left[1 + \frac{\gamma_2 - 1}{2}\right]^{(\gamma_2/(\gamma_2 - 1.))}} - C_{DB} \frac{\gamma_2}{2} M_2^2 X$$

$$\frac{P_{T2}}{\left[1 + \frac{\gamma_2 - 1}{2} M_2^2\right]^{(\gamma_2/(\gamma_2 - 1.))}} = \quad (4.2-30)$$

$$\frac{P_{T4} (1 + \gamma_4 M_4^2)}{\left[1 + \frac{\gamma_4 - 1}{2} M_4^2\right]^{(\gamma_4/(\gamma_4 - 1.))}}$$

Equations (4.2-29) and (4.2-30) define the performance of the engine combustor.

4.2.3.3 Nozzle Performance

The nozzle performance equations are based on the assumption that the isentropic component and the gas constant R are constant as the engine combustion gases are expanded in the engine nozzle. For an isentropic expansion, one may write the following equations.

Sonic velocity relationships

$$C_{5is} = \sqrt{\gamma_4 g_o R_4 T_{5is}} \quad C_{6is} = \sqrt{\gamma_4 g_o R_4 T_{6is}} \quad (4.2-31)$$

Equations of State

$$\rho_{5is} = \frac{P_{5is}}{R_4 T_{5is}} \quad \rho_{6is} = \frac{P_{6is}}{R_4 T_{6is}} \quad (4.2-32)$$

Stream thrust definition

$$ST_{6is} = \frac{\rho_{6is} A_6 V_{6is}^2}{g_o} + P_{6is} A_6 = P_{6is} (1 + \gamma_4 M_2^2) \quad (4.2-33)$$

Stagnation to static fluid property ratios

$$\frac{P_{T4}}{P_{5is}} = \left[\frac{T_{T4}}{T_{5is}} \right]^{\gamma_4 / (\gamma_4 - 1)} = \left[\frac{\gamma_4 + 1.}{2} \right]^{\gamma_4 / (\gamma_4 - 1)} \quad (4.2-34)$$

$$\frac{P_{T4}}{P_{6is}} = \left[\frac{T_{T4}}{T_{6is}} \right]^{\gamma_4 / (\gamma_4 - 1)} = \left[1. + \frac{\gamma_4 - 1.}{2} M_6^2 \right]^{\gamma_4 / (\gamma_4 - 1)} \quad (4.2-35)$$

Conservation of mass

$$W_{4is} = W_{5is} = W_{6is} = \rho_{5is} A_5 V_{5is} \quad (4.2-36)$$

Actual performance of the engine nozzle can be determined by applying the following correction terms to the equations for isentropic flow.

$$W_4 = \rho_4 A_4 V_4 = C_{NM} W_{5is} \quad (\text{Nozzle mass flow coefficient}) \quad (4.2-37)$$

$$ST_6 = \eta_N (ST_{6is}) \quad (\text{Nozzle thrust efficiency}) \quad (4.2-38)$$

When this has been done, one can obtain the following nozzle performance equations.

$$\frac{W_4 \sqrt{T_{T4}}}{A_5 P_{T4} C_{NM}} = \sqrt{\frac{\gamma_4 g_o}{R_4}} \left[\frac{2}{\gamma_4 + 1} \right]^{(\gamma_4 + 1.) / (2. (\gamma_4 - 1))} \quad (4.2-39)$$

$$M_4 = C_{NM} (A_5 / A_4) \left[\frac{2 + (\gamma_4 - 1)}{\gamma_4 + 1} M_4^2 \right]^{(\gamma_4 + 1.) / (2. (\gamma_4 - 1))} \quad (4.2-40)$$

$$M_6 = (A_5 / A_6) \left[\frac{2 + (\gamma_4 - 1)}{\gamma_4 + 1.} M_6^2 \right]^{(\gamma_4 + 1) / (2 (\gamma_4 - 1))} \quad (4.2-41)$$

$$ST_6 = \eta_N P_{6is} A_6 (1. + \gamma_4 M_6^2) \quad (4.2-42)$$

One of the basic assumptions inherent in Eqs. (4.2-39) through (4.2-42) and in the operation of subroutine PROPl is that the Mach number at the nozzle throat is sonic and the Mach number at the nozzle exit is supersonic. Although exceptions to the basic assumptions produce inaccurate results, such exceptions occur only at unusual operating conditions such as very large angles of attack.

4.2.4 Steady State Performance of Ramjet Engine Components

For steady state operation of the ramjet, the mass flows through each section of the engine must be compatible and the fluid properties leaving one engine component must equal those entering the next downstream component. The actual determination of the steady state operating condition of the engine is accomplished by iterative calculations within subroutine PROPI, which are based on the equations presented in the foregoing sections.

4.2.5 Summary of Subroutine PROPI

The assumptions which were presented in the foregoing equation derivations are listed below for the reader's future reference. Additional comments are included to give the reader insight as to how the program use may be extended beyond that described in the foregoing.

The equations in the program are based upon the one dimensional, compressible flow laws of gas dynamics and thermodynamics. Where possible, coefficients and efficiencies have been introduced into the equations so that deviations from ideal flow processes may be accounted for.

The program is capable of computing engine performance for any engine inlet geometry operated at any angle of attack as long as the inlet performance is input in the proper format.

The routine is capable of calculating performance for any fuel whose thermodynamic properties of combustion with air are input in the proper tabular format.

The routine is limited to performance calculations for an engine which uses a convergent-divergent nozzle which has sonic or supersonic flow at its exit. The flow at the nozzle throat is assumed to be choked.

The stagnation temperature at the diffuser exit is assumed equal to the stagnation temperature of the free stream.

The relationships of the working fluid stagnation properties to the fluid static properties at various stations in the engine are assumed to be given by Eqs. (4.2-14), (4.2-20), (4.2-28), (4.2-34), and (4.2-35). The values of γ and R used at various sections in the engine are tabulated below.

<u>Station</u>	<u>Value</u>
0	$\gamma_0 = 1.4$ $R_0 = 53.35 \text{ ft/}^\circ\text{R}$
2	$\gamma_2 = f(T_{T_2})$ $R_2 = f(T_{T_2})$
4 (frozen flow)	$\gamma_4 = f(T_{T_4}, f/a)$
(frozen flow)	$R_4 = f(T_{T_4}, f/a)$
5	$\gamma_5 = \gamma_4$ $R_5 = R_4$
6	$\gamma_6 = \gamma_4$ $R_6 = R_4$

The burner drag coefficient C_{D_B} is assumed to be independent of changes in the flow conditions entering the combustor.

Combustor temperature rise tables must be input into the routine for three user selected combustion chamber pressure levels. For combustion chamber pressures which are intermediate to the tabular pressures, the temperature rise data are found by linear interpolation between the table values. For combustion chamber pressures which are less than the minimum input value, temperature rise is taken to be the same as that for minimum pressure. Similarly, for pressures which exceed the largest pressure level of the tables, the temperature rise is assumed to be the same as that for the largest pressure level of the tables.

Air extraction for accessory power is assumed to occur between the diffuser exit and the fuel injectors of the engine. After this air has been used for accessory power, it is assumed that it is dumped from the missile with momentum recovery which is an input to the routine.

4.2.6 Ramjet Point Design

The basic equations which were derived for the off-design performance subroutine PROP1, are also applicable to the point design subroutine, RJDES. It is only the objectives of the two subroutines which differ. RJDES is used to determine an engine design that will yield a given net thrust coefficient for specified engine operating conditions; PROP1 determines the net thrust coefficient of a given engine design for the specified operating conditions. A summary of the equations used in RJDES is presented in Table I.

The ground rules upon which the point design modeling is based are as follows:

- (a) The inlet is operated critically or supercritically.
- (b) The flow areas at stations 2, 3, and 4 of the engine are equal (see Figure 16).
- (c) Air extraction for auxiliary power is made between stations 2 and 3 (see Figure 16).
- (d) The engine nozzle is a convergent-divergent nozzle and the flow at the nozzle throat is choked.
- (e) If A_6 is not input the nozzle exit plane pressure, P_{6is} , is equal to the ambient atmospheric pressure, P_o , provided the exit area of the nozzle does not have to violate input limits to obtain the equality of these two pressures. If A_6 must violate one of the input limits to obtain $P_{6is} = P_o$, then A_6 is set equal to the constraining limit.

TABLE I

EQUATION SUMMARY FOR SUBROUTINE RJDES

$$P_{T_0} = P_0 \left[1. + \frac{\gamma_0 - 1}{2} M_0^2 \right]^{\gamma_0 / (\gamma_0 - 1)}$$

$$T_{T_0} = T_0 \left[1. + \frac{\gamma_0 - 1}{2} M_0^2 \right] = T_{T_2}$$

$$P_{T_2} = P_{T_0} * (P_{T_2} / P_{T_0})$$

$$\frac{W_A}{A_2} = \frac{P_0}{R_0 T_0} \frac{(A_c)}{A_3} M_0 \sqrt{\gamma_0 g_0 R_0 T_0}$$

$$\frac{W_f}{A_3} = \frac{W_A}{A_2} (1 - \ell) * (f/a)$$

$$M_2 = \sqrt{\frac{R_2}{\gamma_2 g_0}} \frac{W_A}{A_2} \frac{\sqrt{T_{T_0}}}{P_{T_2}} * \left[1. + \frac{\gamma_2 - 1}{2} M_2^2 \right]^{(\gamma_2 + 1) / (2(\gamma_2 - 1))}$$

$$P_2 = P_{T_2} \left[1 + \frac{\gamma_2 + 1}{2} M_2^2 \right]^{(-\gamma_2 / (\gamma_2 - 1))}$$

The following two equations are solved simultaneously for M_4 and P_{T_4} .

$$\frac{P_{T_4} (1. + \gamma_4 M_4^2)}{\left[1. + \frac{\gamma_4 - 1}{2} M_4^2 \right]^{(\gamma_4 / (\gamma_4 - 1))}} = P_2 (1. + \gamma_2 M_2^2) - \frac{\gamma_2}{2} P_2 M_2^2 C_{DB}$$

Conservation of momentum

$$\frac{\frac{W_A}{A_2} (1 - \ell) (f/a) + 1. \sqrt{T_{T_4}}}{P_{T_4}}$$

$$= \sqrt{\frac{\gamma_4 g_0}{R_4}} \frac{M_4}{\left[1. + \frac{\gamma_4 - 1}{2} M_4^2 \right]^{(\gamma_4 + 1) / (2(\gamma_4 - 1))}}$$

Conservation of mass

TABLE I (Continued) EQUATION SUMMARY FOR SUBROUTINE RJDES

$$\frac{A_5}{A_3} = \frac{M_4}{C_{NM}} \left[\frac{\gamma_4 + 1}{2 + (\gamma_4 - 1) M_4^2} \right]^{(\gamma_4 + 1.) / (2. (\gamma_4 - 1.))}$$

$$M_6 = \sqrt{\frac{2}{(\gamma_4 - 1.)} \left[\frac{P_{T4}}{P_o} - 1. \right]^{((\gamma_4 - 1.) / \gamma_4)}}$$

$$\frac{A_6}{A_5} = \frac{1}{M_6} \left[\frac{2 + (\gamma_4 - 1.) M_6^2}{\gamma_4 + 1.} \right]^{(\gamma_4 + 1.) / (2. (\gamma_4 - 1.))}$$

$$\frac{A_6}{A_3} = \left[\frac{A_6}{A_5} \right] * \left[\frac{A_5}{A_3} \right]$$

If (A_6/A_3) is set equal to 1 then $(A_6/A_5) = (A_3/A_5)$

and

$$M_6 = \frac{1}{(A_3/A_5)} * \left[\frac{2. + (\gamma_4 - 1.) M_6^2}{\gamma_4 + 1.} \right]^{(\gamma_4 + 1.) / (2. (\gamma_4 - 1.))}$$

$$P_{6is} = P_{T4} * \left[1 + \frac{\gamma_4 - 1}{2} M_6^2 \right]^{(-\gamma_4 / (\gamma_4 - 1.))}$$

$$C_{FN} = \left[\frac{A_6}{A_3} \right] \frac{1.}{\gamma_o M_o^2} \left[\left(\frac{P_{6is}}{P_o} \right) * \eta_N * (1. + \gamma_4 M_6^2) - 1. \right] - 2. \left[\frac{A_c}{A_3} \right]$$

$$SFC = \frac{7200. * g_o * (A_c/A_3) * f/a * (1. - l)}{C_{FN} * M_o * \sqrt{\gamma_o g_o R_o T_o}}$$

Note: Nomenclature for this section is presented in Table III (p. F-96).

4.3 Ramjet Combustor Mass Properties

4.3.1 Internal Rocket Ramjet

The internal rocket ramjet uses the same combustor as the booster. Mass properties are calculated in subroutine BOOST and are described in Appendix B.

4.3.2 Non-Integral Rocket Ramjet

4.3.2.1 Combustor Design

Subroutine EXRAM is used to size the combustion chamber whenever the ramjet vehicle being designed is not an integral rocket/ramjet configuration.

In order to determine the thicknesses of the closures and chamber sidewalls, the routine must first obtain the maximum combustor pressure. The expected maximum pressure seen in the combustor will be based on design conditions (Mach number, altitude, and angle of attack) input by the user. The most severe conditions will generally be the highest Mach number at the lowest altitude to be flown by the ramjet. At these conditions the angle of attack will usually be small (a value of 1.0 is recommended for most designs). Static pressure is obtained from a one-dimensional table look-up as a function of altitude.

$$P_o = f(\text{altitude})$$

Total pressure is calculated by subroutine ISEN as

$$P_{T_o} = f(T_o, M_\infty)$$

Pressure recovery is obtained from a double table look-up from the input inlet deck for a given Mach number and angle of attack.

$$P_{TR} = f(M_\infty, \alpha)$$

The combustor chamber pressure is obtained from pressure recovery and total pressure, as

$$P_{cc} = P_{T_o} * P_{TR} / 144.$$

Chamber material properties (density, yield and ultimate tensile strengths) are obtained from Subroutine MATLS.

The combustor diameter will be the vehicle diameter less the external insulation, if any.

$$D_S = D_3 - 2 \cdot T_{ex}$$

Closure and sidewall thickness will be based on the maximum of the thickness based on yield, the thickness based on ultimate, and input minimum values

$$T_c = \frac{F_s \cdot P_{cc} \cdot D_s}{2 \cdot F_T}$$

$$T_D = \frac{F_s \cdot P_{cc} \cdot E \cdot D_s}{4 \cdot F_T}$$

The forward closure surface area and weight are calculated as follows:

$$E \neq 1$$

$$S = 1 - \frac{1}{E^2}$$

$$S_D = \frac{\pi D_s^2}{4} + \frac{\pi D_s^2}{8 E^2} \log \frac{1+s}{1-s}$$

$$E = 1$$

$$S_D = \pi D_s^2 / 2$$

Forward closure weight, where C_4 is miscellaneous forward dome weight

$$Wt_{FC} = T_d \cdot \rho \cdot S_D + C_4$$

Forward insulation weight

$$Wt_{FI} = T_I \cdot \rho_I \cdot S_D$$

Dump stiffeners surrounding the inlet dump ports are assumed to be equal in area to the dump port area plus 1/6 of the combustor cross-sectional area. The thickness of the dump stiffeners is assumed to be equal to the case thickness. The additional weight to be added to the case (as the dump port area will not be subtracted from the cylindrical weight) is, then, where C_1 is a weight multiplier (usually 1)

$$W_{t_{DB}} = \frac{A_3}{6} * \rho * T_c * C_1$$

Volume available in the forward and aft domes is

$$V_D = \frac{\pi * (D_s - 2 * (T_I + T_d))^{**3}}{6 E}$$

Sizing of the combustor will be based on the LSTAR parameter, that is

$$LSTAR = V_{tot} / A_{throat}$$

where LSTAR is an input. Values below 40 inches will adversely affect the combustion efficiency while a value of 60 inches is recommended for conservative design.

$$V_{req} = LSTAR * A_5$$

Cylindrical volume

$$V_{cyl} = V_{req} - V_{dome}$$

Cylindrical length

$$X_{cyl} = V_{cyl} / \left(\frac{\pi}{4} * [D_s - 2 * (T_c + T_{ins})]^2 \right)$$

Weight of the cylindrical case

$$W_{cyl} = \pi * D_s * T_c * \rho + C_5$$

where C_5 is miscellaneous cylinder weight.

Weight of the cylindrical insulation

$$W_{inc} = \pi * (D_s - 2 * T_{ins}) * T_{ins} *$$

4.3.2.2 Nozzle Design

Nozzle design equations are as follows (see Figure 17).

Exit radius

$$R_6 = \sqrt{A_6/A_3} * R_3$$

Throat radius

$$R_5 = \sqrt{A_5/A_3} * R_3$$

Throat area

$$R_c = 0.4 * R_5$$

If the height of the entrance section is greater than 80 percent of the available height ($R_3 - R_5$), it is set equal to $0.8 * (R_3 - R_5)$. Then

$$Y_z = R_c * (1 - \cos \theta)$$

or

$$Y_z = 0.8 * (R_3 - R_5)$$

Exit cone length

$$XB = [R_6 - R_c * (1 - \cos \theta)] - R_5 / \tan \theta$$

Exit side of throat segment

$$XA = R_c * \sin \theta$$

Entrance section length

$X3 = R * \sin \theta$ Note theta would have been adjusted from the input value if YZ was set equal to $0.8 * (R_3 - R_5)$

Entrance radius

$$Y1 = YZ + R_5$$

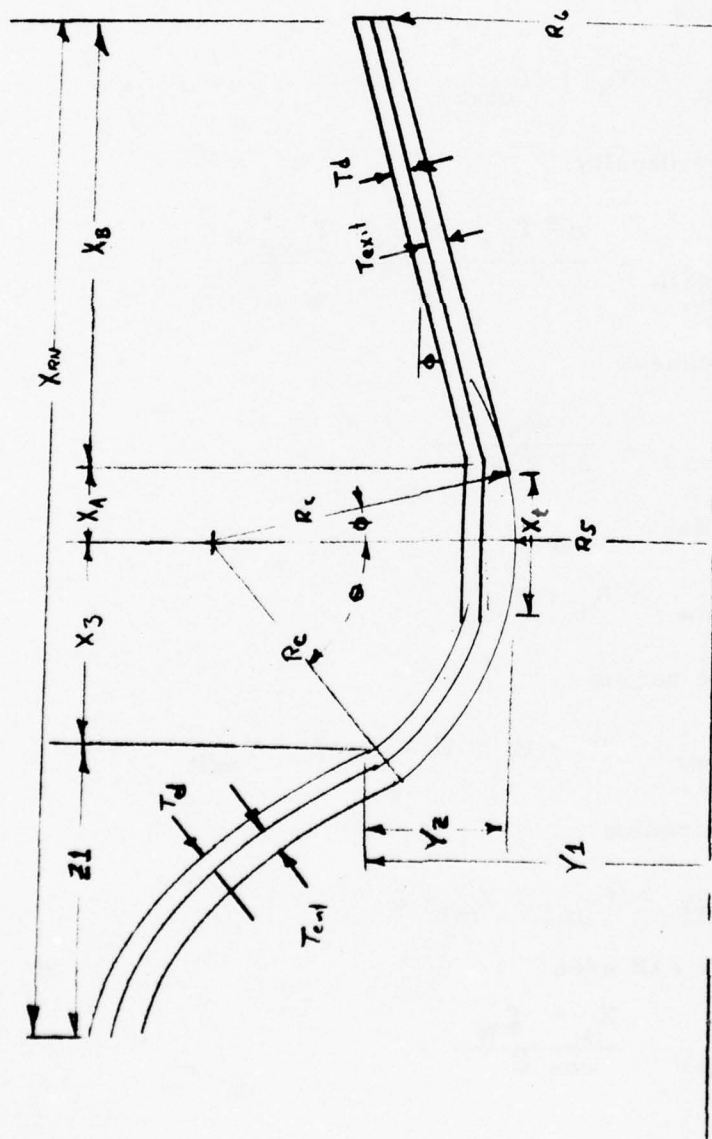

F-63

Figure 17 Ramjet Nozzle

Length of the aft dome

$$Z_1 = \sqrt{\frac{R_3^2 - Y_1^2}{E^2}}$$

The nozzle length as defined in EXRAM includes the length of the aft dome,

$$X_{RN} = Z_1 + X_3 + X_A + X_B$$

Weight of the exit cone section is derived as follows:

Thickness

$$\delta_n = T_d + T_{\text{exit}}$$

Effective density

$$\rho_{\text{exit}} = \frac{\rho * T_d + \rho_{\text{exit}} * T_{\text{exit}}}{\delta_n}$$

Half thickness

$$Y_{\text{exit}} = \frac{\delta_n}{2 * \cos \theta}$$

Exit radius

$$Y_{ms} = R_6 + Y_{\text{exit}}$$

Entrance radius

$$Y_{mz} = R_5 + R_c * (1 - \cos \theta) + Y_{\text{exit}}$$

Average radius

$$R_{B1} = (Y_{m1} + Y_{m2})/2$$

Effective exit area

$$A_{B1} = \frac{X_a * \delta_N}{\cos \theta}$$

Weight of the exit section

$$W_{\text{exit}} = 2 * \pi * A_{B1} * R_{B1} * \rho_{\text{exit}}$$

Weight of the throat section

Length of the throat section

$$X_T = 2 * X_B$$

Effective density

$$\rho_T = \frac{\rho * T_d + 1.5 * \rho_{\text{THT}} * T_{\text{THT}}}{T_d + 1.5 * T_{\text{THT}}}$$

Thickness

$$\delta_m = T_d + T_{\text{THT}} * 1.5$$

Effective throat area

$$A_{B2} = X_T * \delta_m$$

Effective radius

$$R_{B2} = R_5 + \delta_m / 2$$

Weight of the throat section

$$W_{\text{THT}} = 2 * H * A_{B2} * R_{B2} * \rho_T + C_6$$

where C_6 is the miscellaneous throat weight.

Entrance section weight

Section length parallel to centerline

$$X_E = X_3 - X_B$$

Thickness

$$T_e = T_d + T_{ent}$$

Section height

$$Y_{m3} = Y_Z - T_c / 2$$

Section length

$$X_4 = \sqrt{X_E^2 + (Y_{m3} - Y_{m2})^2}$$

Section radius

$$R_{B3} = \frac{Y_{m3} + Y_{m2}}{2}$$

Section effective density

$$\rho_e = \frac{\rho * T_d + \rho_{ent} * T_{ent}}{T_e}$$

Section area

$$A_{B3} = X_4 * T_e$$

Entrance section weight

$$W_{ent} = 2 * \pi * \rho_e * A_{B3} * R_{B3}$$

Nozzle weight

$$W_{RN} = W_{exit} + W_{THT} + W_{ent}$$

4.3.2.3 Combustor Weights

Aft dome weights are derived as follows:

Area of the port

$$A_p = \pi Y_1^2$$

Dome area

$$S_{AD} = S_D - A_p$$

Aft dome weight

$$Wt_{DA} = \rho * T_d * S_{AD}$$

Aft insulation weight

$$Wt_{ID} = \rho_{ins} * T_{ins} * S_{AD}$$

Aft skirt/fairing weight

$$Wt_{AS} = \pi * D_s * T_{minc} * XRN * \rho * C_2$$

where C_2 is a multiplier.

Forward skirt weight

Skirt length

$$XSK = \frac{D_s}{2 * E} + \text{Clear}$$

Forward skirt weight

$$Wt_{SK} = \pi * D_s * T_{minc} * XSK * \rho * C_2$$

Attachment weights

$$Wt_{at} = 4 * \pi * D_s * T_{minc} * \rho * C_3$$

where C_3 is a multiplier

External insulation weight

$$Wt_{EIN} = \pi * D_3 * XRJ * T_{ex} * \rho_{ex}$$

The ramjet combustor weight is, then,

$$\begin{aligned} WRJ = & Wt_{FC} + Wt_{FI} + W_{RN} + Wt_{CYL} + Wt_{INC} \\ & + Wt_{DA} + Wt_{ID} + Wt_{AS} + Wt_{SK} + Wt_{at} \\ & + Wt_{EIN} + Wt_{DB} \end{aligned}$$

4.3.2.4 Modeling of Combustor MOI and CG

Moments of inertia and centers of gravity for the ramjet combustor components are computed according to the assumptions shown on Table II.

4.4 Ramjet Booster Sizing

Integral and non-integral ramjet booster sizing is discussed in Appendix D.

TABLE II
COMBUSTOR MOI AND CG MODELING

<u>Item</u>	<u>Segment</u>	<u>Physical Model</u>	<u>Remarks</u>
1	Fwd Dome	Semi elipsoidal or spherical shell	Includes misc. fwd wts
2	Fwd Insulation	Semi elipsoidal or spherical shell	
3	Dump stiffner	Cylindrical shell	
4	Sidewall Case	Cylindrical shell	Includes misc. cyl wts
5	Sidewall Insulation	Cylindrical shell	
6	External Insulation	Cylindrical shell	
7	Fwd Skirt Weight	Cylindrical shell	
8	Fwd Attachment Wt	Cylindrical shell	
9	Aft Skirt/Fairing	Cylindrical shell	
10	Aft Attachment Wt	Cylindrical shell	
11	Aft Dome	Semi elipsoidal or spherical shell	
12	Aft Insulation	Semi elipsoidal or spherical shell	
13	Nozzle Entrance	Truncated Conical shell	
14	Nozzle Throat	Truncated Conical shell	Includes misc. nozzle wts
15	Nozzle Exit	Truncated Conical Shell	

4.5

Sustainer Mass Properties (Subroutine SUSMAS)

The sustainer section consists of two subsections; the sustainer fuel tank and the fuel management bay. The fuel management bay houses the fuel management system and the secondary power package. An alternate approach of placing the secondary power package around the combustor nozzle, favored by Martin in the CAMS routine, has not been incorporated for the following reasons:

- (a) The nozzle must be extended by use of a nozzle blast tube. As the blast tube has a relatively large cross section, the area made available per linear inch of blast tube is considerably less than if a clear section forward of the booster is utilized.
- (b) Because of the high temperatures, high Mach number, and long cruise times involved, design of a ramjet nozzle is a very difficult problem. Adding a blast tube will compound this problem.
- (c) Heat transfer across the blast tube wall will be substantial. Thermal protection of all components located around the nozzle will be difficult.
- (d) It may be desirable to physically combine the fuel management hardware and the secondary power hardware.

Four fuel management/expulsion systems are available to the user:

- (a) Pressurized expulsion
 - (1) N_2
 - (2) Liquid gas generator
 - (3) Solid gas generator
- (b) Pump expulsion
 - (1) Ram air turbine

4.5.1

Calculation of Design Fuel Flow Rate

In order to size the fuel controller and pump or pressurization system, the subroutine must be supplied with the design conditions (the Mach number, altitude, angle of attack, and fuel-to-air ratio) at which the maximum fuel flow rate will occur. This will generally be the highest

Mach number at the lowest altitude the vehicle will be required to fly. An angle of attack of 1.0 degrees and a fuel-to-air ratio of 0.04 are recommended values if exact values are not known. Selection of the fuel-to-air ratio and angle of attack are not critical; relatively large differences between the correct value and the value supplied will have negligible impact on the ramjet design.

Using the input design altitude the routine obtains the static temperature and pressure from a one-dimensional table look-up.

$$T_o, P_o = f(\text{altitude})$$

Next, the total temperature and pressure are obtained using subroutine ISEN and the design Mach number

$$T_{T_o}, P_{T_o} = f(M_\infty, T_o, P_o)$$

$$T_{T_2} = T_{T_o}$$

Critical pressure recovery and mass flow ratios are obtained from two-dimensional table look-up as a function of Mach number and angle of attack

$$P_{T_R}, A_o/A_c = f(M_\infty, \alpha)$$

Combustor chamber pressure is calculated next

$$P_{CC} = T_{T_o} * P_{T_R} / 144.$$

With the above information plus the design fuel-to-air ratio, the fuel flow constant is calculated

$$C = .918744 * \frac{P_o * M_\infty}{T_o} * A_3 * A_o/A_c * f/a$$

This constant when combined with the ramjet capture area ratio gives the design fuel flow rate

$$\dot{W}_{f_{\max}} = A_c/A_3 * C$$

4.5.2 Tank Design

The tank diameter is the vehicle diameter less the thickness of the external insulation (if any)

$$D_T = D_3 - 2 * T_{EXI}$$

Pressure in the tank for pressurized systems is assumed to be increased by an input pressure drop fraction

$$P_{\text{tank}} (1 + \Delta P) * P_{cc}$$

As the tank design pressure will generally not exceed 250 psia, the input minimum case thickness based on handling, buckling and bending considerations will usually be controlling.

The weight and/or length of the sustainer tank is derived from what is left over after the payload, booster, aerodynamic surfaces and fuel management bay have been sized. To facilitate calculations the routine first sizes a minimum tank configuration consisting of skirts, attachment rings, and the elliptical domes with bladder and fuel. The increase in overall weight and fuel weight per inch of tank length are also calculated. On each subsequent call to the routine the tank can be sized to meet the available length or weight without repeating the minimum tank calculations.

If a Ram Air Turbine is used, the thickness of the tank cylinder and dome ends will be based on the input minimum value. If any of the other systems are selected, the tank thicknesses will be the maximum of the thickness based on yield, the thickness based on ultimate and the input minimum thickness. Yield and ultimate tensile strengths are supplied by subroutine MATLS at the sustainer tank design temperature. Density is also supplied by MATLS but is assumed to be independent of temperature. Material properties are listed in Section 4.8.

$$T_C = \frac{\text{F.S.} * P_{\text{TANK}} * D_T}{2 * F_T}$$

$$T_D = \frac{T_C * E}{2}$$

Minimum length

$$L_{\text{min}} = D_T / E$$

T_C = cylinder thickness

F.S. = factor of safety, e.g., 2.0

F_T = ultimate or yield tensile strength

T_D = dome thickness

E = Ellipse ratio

Note that, if the length available for the sustainer is less than the minimum length, the case being calculated is terminated.

External insulation weight per unit length

$$\Delta_{EX} = \frac{D}{3} * T_{ex_I} * \rho_{ex_I}$$

External insulation weight on minimum length

$$Wt_{EX_I} = \Delta_{EX} * L_{min}$$

Sustainer tank ends are assumed to be elliptical rather than spherical. If an ellipse ratio of 1 is input an error will occur.

$$S = \sqrt{1 - \frac{1}{E^2}}$$

Dome surface area

$$S_D = \frac{\pi D_t^2}{2} + \frac{\pi D_t^2}{4E^2 S} \log \frac{1+S}{1-S}$$

Dome weight

$$Wt_D = T_D * S_D * \rho$$

Bladder weight in dome area

$$Wt_B = T_B * S_D * \rho_B$$

Fittings and fill port weights

$$Fittings = Wt_D * 0.25$$

4.5.2.1 Stand Pipe Weights

The design assumes that the fuel will be contained in a bladder and that a stand pipe will run the length of the cylindrical section to prevent entrapment of large amounts of fuel. Calculation of the weight of the stand pipe per inch of length is as follows, if $V = 50 \text{ ft/sec}$ and $\rho = 49 \text{ lb/ft}^3$.

$$\dot{W}_f = \rho A V$$

$$\dot{W}_f = 49 * \frac{D_I^2 * \pi * 50}{4 * 144}$$

$$D_I^2 = .0748 \dot{W}_f$$

$$D_I = .2736 \dot{W}_f \quad (\text{assume tube wall} = .02 \text{ in.})$$

$$D_o = .2736 \dot{W}_f + .04$$

$$Wt_L = D_o * \pi * .02 * \rho \quad (\text{assume } \rho = .283 \text{ lb/in}^3)$$

$$Wt_L = .0178 D_o$$

4.5.2.2 Flange Weights

In order to achieve a rational method for estimating the weight of splice rings and joints, a standard model is established. Figure 18 shows a sketch of the joint that connects one section to the next. The basic thickness at the joint is assumed to be twice that of the basic skin, and a partial bulkhead is provided for mounting internal equipment.

The stress concentration in the basic shell wall is minimized by thickening the wall over a length such that the characteristic shell parameter is given as

$$\beta_l = 3$$

where

$$\beta = \sqrt[4]{\frac{3(1-V^2)}{R^2 h^2}}$$

Taking $V = 0.3$ as a typical value, the joint semi-length becomes

$$l = 2.34 Rh$$

The shaded area shown in Figure 18 represents the weight to be added to the skin weight to account for the splice ring connection at the intersection of each end of a body section. This weight is obtained from the following equation:

$$W_R = 44.1 (Rh)^{1.5} \rho + 2.75 R^2 h \rho$$

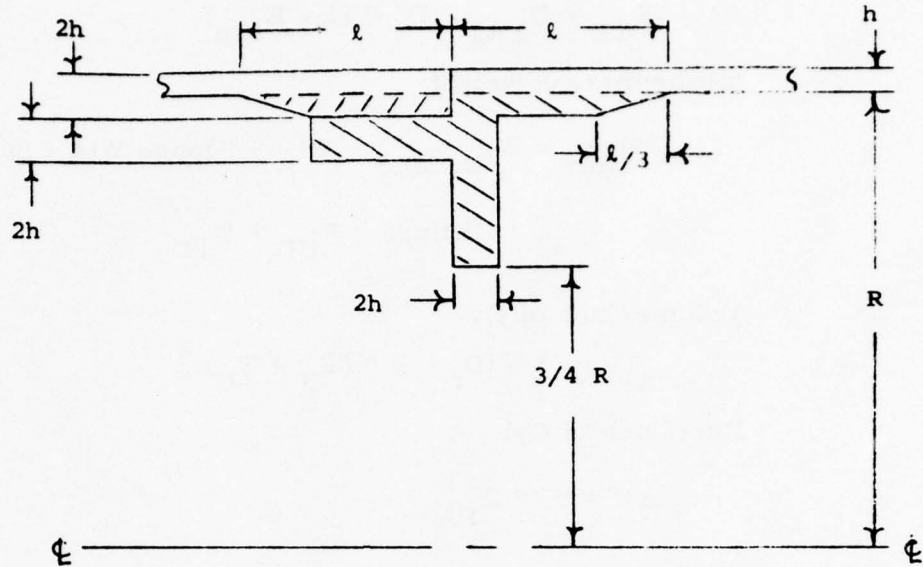

FIGURE 18

SPLICE RING MODEL

Flanges of the type shown are assumed to be attached to both ends of the sustainer section.

Skirt weights

$$\text{Skirts} = \rho * D_t * T_c * L_{\text{min}} * \pi$$

Dome volume

$$D_v = \frac{(D_t - 2 * (T_B + T_D))^3}{6 * E}$$

Adjusted fuel density accounts for both ullage and allowance for density change due to temperature

$$D_{\text{FAJ}} = (\rho_{\text{fuel}} - \Delta\rho_T (T_{\text{fuel}} - 75)) * (1 - \text{ULLG})$$

Usable fuel in domes

$$F_{\text{UD}} = D_{\text{FAJ}} * D_v * E_{\text{exp}}$$

Trapped fuel

$$F_{TD} = D_{FAJ} * D_v * (1 - E_{exp})$$

Minimum tank weight

$$Wt_{min} = Wt_{DOMES} + Wt_B + \text{Flange Wts} + \text{Skirts} + Wt_{EXI} \\ + \text{Fittings} + F_{UD} + F_{TD}$$

Volume/Inch of Cyl

$$\Delta V = \frac{\pi}{4} * (D_t - 2 * (T_B + T_C))^2$$

Fuel/Inch of Cyl

$$\Delta F = V_I * D_{FAJ}$$

Bladder/Inch of Cyl

$$\Delta B = \pi * D_t * T_B * \rho_B$$

Case/Inch of Cyl

$$\Delta C = \pi * D_t * T_c * \rho + Wt_L$$

Wt/Inch of Cyl

$$Wt = \Delta F + \Delta B + \Delta C + \Delta Ex$$

4.5.3 Fuel Controller Weight

Sizing of the fuel control system is based on an empirical equations modelled on vendor experience.

$$W_{FC} = 10 + \frac{2}{3} * \dot{W}_{fmax}$$

4.5.4 Expulsion System Sizing

4.5.4.1 Nitrogen System

The nitrogen system sizing is based on the volume of gas required to pressurize the sustainer tank to a pressure slightly in excess of

the maximum combustor pressure. As the volume and weight of the tank will depend on the volume and weight of the expulsion system (and vice versa) calculation of the nitrogen system is necessarily iterative.

$$P_{\text{final}} = P_{\text{tank}} + P_{\text{reg drop}}$$

$$V_{\text{req}} = D_V + \Delta V * X_{\text{cyl}}$$

$$W_{\text{NB}} = \frac{\frac{(1 + (\gamma_{\text{N2}} - 1)) * Z_p}{1 - P_{\text{final}} * Z_o}}{P_{\text{N2}} Z_p}}$$

$$W_{\text{t}_{\text{N2}}} = \frac{W_{\text{NB}} * P_{\text{final}} * V_{\text{req}}}{Z_p * R_F * T_N * 12}$$

Built-in routine values include

$$T_N = 530$$

$$Z_p = 1.0$$

$$Z_o = 1.03$$

$$\gamma_{\text{N2}} = 1.401$$

The nitrogen system volume is calculated in subroutine FMBPAK.

4.5.4.2 Liquid Gas Generator System

The liquid monopropellant gas generator fuel weight and loaded weight is calculated from the curve fit of Figures 19 and 20.

The gas generator flow rate and fuel volume are based on the maximum fuel flow rate and the sustainer burn time

$$\dot{V}_B = \frac{\dot{W}_{f_{\text{max}}}}{\rho_{\text{fuel}}}$$

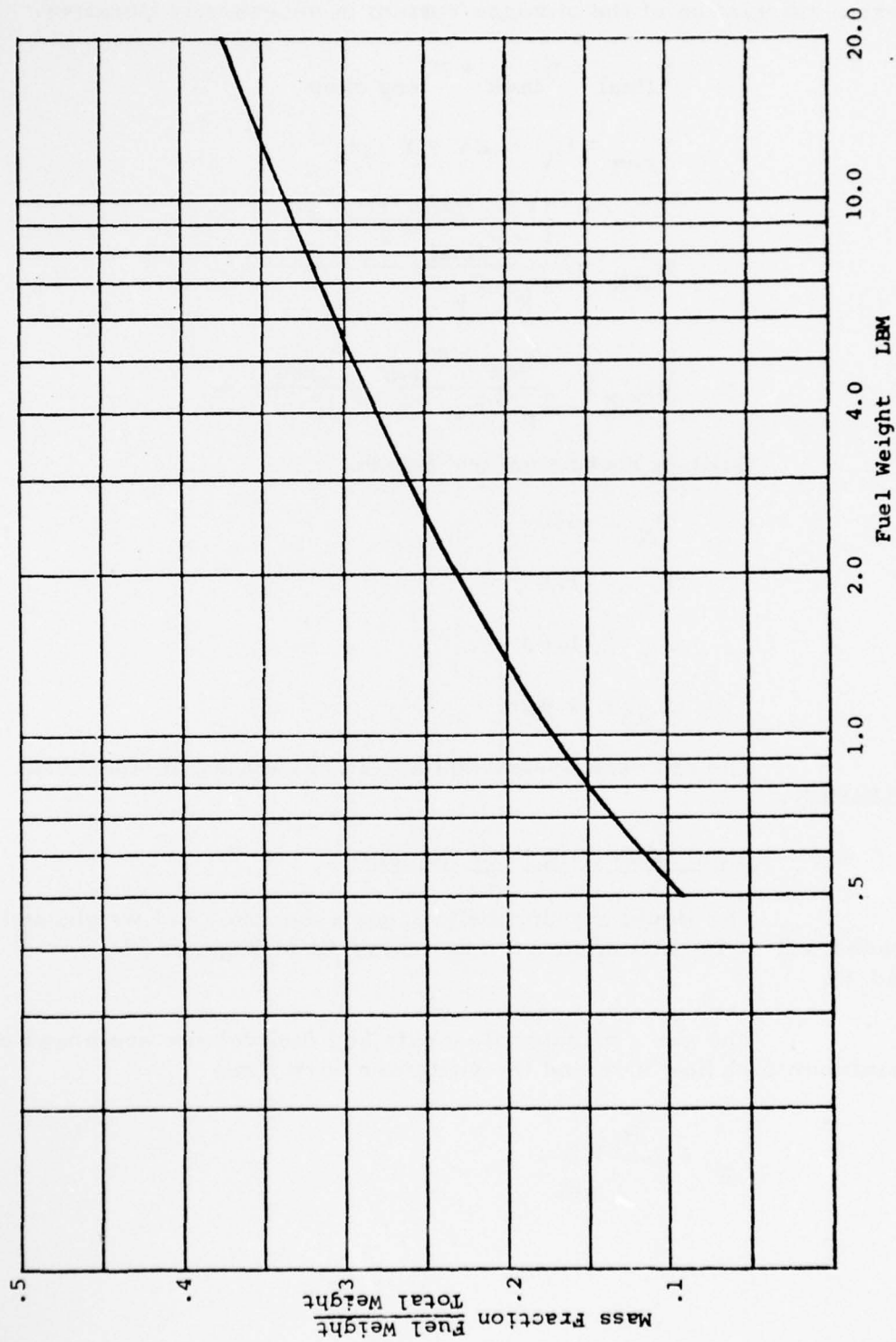

Figure 19 Liquid Gas Generator Mass Fraction

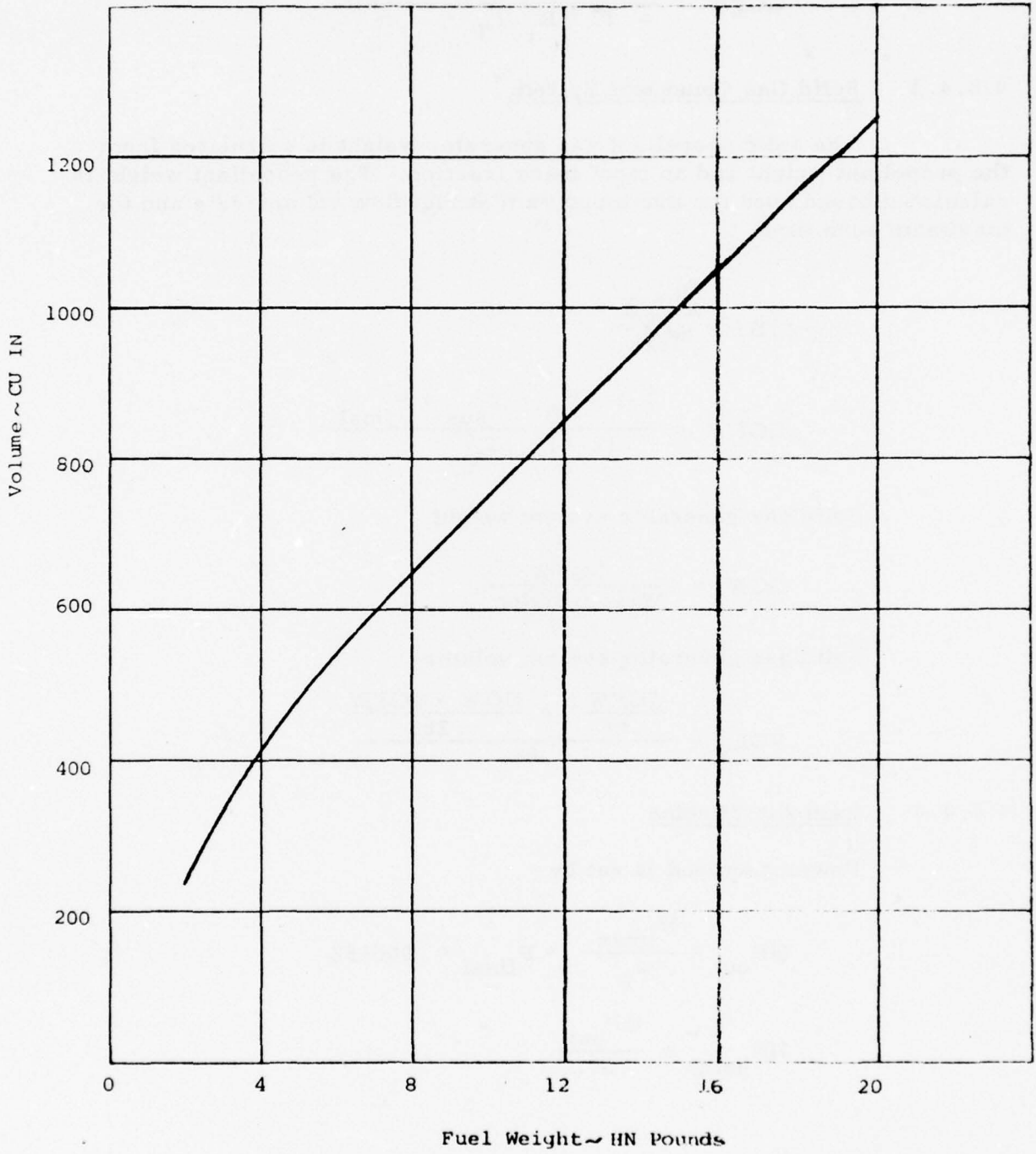

Figure 20 Liquid Gas Generator Scheme

Gas generator fuel weight

$$\text{GGFW} = \frac{1.1 * \dot{V}_B * T_{\text{sus}} * P_{\text{final}}}{12 * R_F T_T}$$

4.5.4.3 Solid Gas Generator System

The solid propellant gas generator weight is calculated from the propellant weight and an input mass fraction. The propellant weight is calculated based upon the maximum ramjet fuel flow volume rate and the maximum burn time.

$$V_B = \frac{\dot{W}_{f\text{max}}}{\rho_{\text{fuel}}}$$

$$\text{GGFW} = \frac{1.1 * V_B * T_{\text{sus}} * P_{\text{final}}}{12 * R_F T_T}$$

Solid gas generator system weight

$$\text{GGW} = \frac{\text{GGFW}}{\text{Mass fraction}}$$

Solid gas generator system volume

$$\text{VOL}_X = \frac{\frac{\text{GGFW}}{.06} + \frac{\text{GGW} - \text{GGFW}}{.283}}{.85}$$

4.5.4.4 Ram Air Turbine

Power required is set by

$$\text{HP}_{\text{out}} = \frac{\dot{W}_{f\text{max}}}{\rho_F} * P_{\text{final}} * .000152$$

$$\text{HP}_{\text{pump}} = \frac{\text{HP}_{\text{out}}}{.85}$$

The pump weight is calculated below, except that it has a minimum value of 2 pounds.

$$\text{Pump Wt} = (\text{HP}_{\text{pump}} - 7) * .38 + 2$$

The turbine weight is calculated below, except that it has a minimum value of 3.7 pounds.

$$\text{Turbine Wt} = (\text{HP}_{\text{pump}} - 7) * .57 + 3.7$$

The turbine volume is calculated below, except that it has a minimum value of 36.5 in³.

$$\text{Turbine Volume} = 36.5 + 14.5 * (\text{HP}_{\text{pump}} - .65)$$

The system weight is given by

$$\text{Wt}_{\text{sys}} = 1.2 * (\text{Turbine Wt} + \text{Pump Wt})$$

For packaging purposes the ram air turbine is assumed to have a diameter of 3.625 inches.

As indicated above, calculation of the dome ends and of the change in weights and volumes with length is performed on the 1st pass through the routine. These calculations need not be repeated during subsequent passes.

Length and weight of the fuel management bay are calculated in subroutine FMBPAK. Sustainer minimum values are then calculated.

$$\text{Sustainer min length} = L_{\text{min}} + X_{\text{FMB}}$$

$$\text{Sustainer min weight} = \text{Wt}_{\text{min}} + \text{Wt}_{\text{FMB}}$$

The design problem being solved may be either weight- or length-constrained. In either case the weight and length of all other vehicle components will be known at the time SUSMAS is called. The allowable sustainer cylinder length (weight) will be what is left over after the other vehicle component lengths (weights) and the sustainer minimum length (weight) are subtracted from the total vehicle length (weight)

$$X_{\text{cyl}} = X_{\text{tot}} - \sum_{i=1}^j X_{\text{Ci}} - X_{\text{min}}$$

If X_{cyl} is negative the design case is terminated. If the vehicle design constraint is vehicle length, the cylindrical length is obtained directly. If the design constraint is vehicle weight cylindrical length is obtained from:

$$L_{CYL} = X_{cyl} / \Delta Wt$$

4.5.5 Sustainer MOI and CG Modeling

Calculation of the sustainer C. G. and MOI is straightforward. Components and the solid models used are listed in Table III.

TABLE III
SUSTAINER MOI AND CG MODELING

<u>Item</u>	<u>Component</u>	<u>Solid Model</u>	<u>Remarks</u>
1	Fittings	Point Mass	
2	Fwd dome	Semi elipsoidal shell	
3	Fwd bladder	Semi elipsoidal shell	
4	Fwd flange	Cylindrical shell	
5	Fwd skirt	Cylindrical shell	
6	External Insulation	Cylindrical shell	
7	Case sidewall	Cylindrical shell	Includes standpipe wt.
8	Sidewall bladder	Cylindrical shell	
9	Aft skirt	Cylindrical shell	
10	Aft flange	Cylindrical shell	
11	Aft dome	Semi elipsoidal shell	
12	Aft bladder	Semi elipsoidal shell	
13	Fwd propellant	Semi elipsoidal solid	
14	Cylindrical propellant	Cylindrical solid	
15	Aft propellant	Semi elipsoidal solid	
16	Trapped propellant	Cylindrical shell	

4.6 Fuel Management Bay Configuration and Mass Properties

Components packaged in the fuel management bay are discussed in this section and are grouped as follows:

- (a) The power source for the aerodynamic control surfaces actuation system (secondary power package)
- (b) The fuel controller
- (c) The power source for the fuel expulsion system

4.6.1 Secondary Power Package

The weight of the secondary power system ($W_{t_{SP}}$) is calculated in subroutine PROPXX as a fraction of total vehicle weight.

$$W_{t_{SP}} = W_{T_{TOT}} * SP_{wf}$$

$$\left\{ \begin{array}{l} W_{T_{TOT}} = \text{missile weight} \\ SP_{wf} = \text{secondary power package weight fraction} \end{array} \right.$$

The secondary power package weight fraction is a user input. The following is suggested as a guide for the value to be input.

<u>Secondary Power System</u>	<u>System</u>	
	<u>Ram Air Turbine</u>	<u>Battery</u>
SP_{wf}	.025	.03 + .01 per 100 sec flight time
Bleed Fraction	6% to 8%	3% to 5%

The volume which should be allocated to the secondary power package will vary between 10 and 16 in³ per pound, depending upon the degree of sophistication assumed.

4.6.2 Fuel Control System

The weight of the fuel controller is calculated by SUSMAS according to the empirical formula.

$$WFC = 10 + \frac{2}{3} (\text{Max Fuel Flow Rate}) \quad \text{where Max Fuel Flow Rate is in lbs/sec}$$

The volume occupied by the fuel control system is estimated at 10 inches per pound.

4.6.3 Power Source for Fuel Expulsion System

As discussed in Section 4.5 of this appendix, the fuel expulsion system may be any of the following:

- (a) Nitrogen bottle
- (b) Liquid gas generator
- (c) Solid gas generator
- (d) Ram air turbine

Weights and volumes of the latter of these systems are calculated in SUSMAS and discussed in Section 4.5. The weight and volume of the N₂ required is also calculated in SUSMAS and discussed in Section 4.5, but the packaging is calculated in FMBPAK.

The material code for the N₂ bottles is an input. Density and tensile strength are supplied by subroutine MATLS based on the input code and temperature requirements.

The radius of each N₂ bottle (R_N) is calculated as follows

$$\theta = \frac{360}{2 X_n}$$
$$R_N = \frac{\sin \theta}{(\sin \theta + 1)} (R_B - X_2 - X_1)$$

X_n = number of N₂ bottles
R_B = radius available for N₂ bottles
X₂ = half the clearance between N₂ bottles
X₁ = clearance between N₂ bottles and missile skin

Bottle wall thickness (T_c)

$$T_c = \frac{F_{ult} P_{N2} R_N}{\sigma_{ult}}$$

F_{ult} = factor of safety, ultimate
P_{N2} = nitrogen pressure
σ_{ult} = ultimate tensile strength

T_c is not permitted to be less than 0.04 in.

If the number of N₂ bottles is input as a negative number the bottles will have a spherical dome, otherwise it will be elliptical.

Spherical

$$S = 4\pi R_n^2$$

S = surface area

Elliptical

$$S_{ef} = 1 - \frac{1}{E^2}$$

E = ellipse ratio

$$S = \frac{\pi R_N^2}{2} + \frac{\pi R_N^2}{4 E^2 S_{ef}} \quad l_n \quad \frac{1 + S_{ef}}{1 - S_{ef}}$$

$$T_d = \frac{F_{ult} P_{N2} R_N E}{\sigma_{ult}^2}$$

T_d = dome thickness

T_d is not permitted to be less than 0.04 in.

$$Wt_D = S \rho_N X_n T_D$$

ρ_n = density of N₂ bottle material

$$V_D = \frac{4\pi (R_N - T_D)^3 X_n}{3 E}$$

Weight of cylinders per lineal inch (W_{T_I}) and volume (V_I) per lineal inch

$$Wt_I = 2\pi R_n T_c \rho_n$$

$$V_I = (R_n - T_c)^2 \pi X_n$$

If the entire volume required is equal to the volume available in the N₂ bottle domes, the bottle weight (W_s) is assumed to be equal to the dome weight and the required length (XF)^s equal to the depth of N₂ bottle domes plus the input clearance value

$$W_s = Wt_D$$

$$XF = \frac{2 * R_N}{E} + CLR \quad CLR = \text{input clearance area}$$

If the volume required is less than the volume available in the N₂ bottle domes, the required length (XF) is calculated thus

$$\text{Length of cyl} = \frac{V_{REQ} - V_D}{V_I}$$

$$XF = \text{Length of cyl} + \frac{2 * R_N}{2} + CLR$$

and the weight $W_S = Wt_D + (\text{length of cyl}) Wt_I$

If the volume required is less than the volume available in the domes, the radius is reduced until the volume required is packaged in spheres or ellipsoids.

The weight of the expulsion system is

$$Wt_E = W_S + W_{N2} \quad W_{N2} = \text{weight of } N_2 \text{ required}$$

4.6.4 Final Fuel Management Bay Calculations

For N_2 bottles it is assumed that the fuel controlled can be packaged in the void area between the N_2 bottles. The length required for the secondary power package is

$$L_{ss} = Wt_{sp} \text{ VPP PKD} \quad \left\{ \begin{array}{l} \text{VPP} = \text{volume per pound (SPP)} \\ \text{PKD} = \text{packing density reciprocal} \end{array} \right.$$

Then the fuel management bay length (XFMB) is given by

$$XFMB = L_{ss} + XF$$

For systems other than N_2 bottles, the length (XFMB) is

$$\text{VOL} = \text{VOLX} + 10WFC + Wt_{sp} \text{ VPP} \quad \left\{ \begin{array}{l} \text{VOLX} = \text{expulsion system volume} \\ \text{A}_{line} = \text{area of fuel lines} \end{array} \right.$$

$$XFMB = \frac{\text{VOL}}{R_B^2 \pi - A_{line}} \text{ PKD} + CLR$$

In no case is the fuel management bay length permitted to be less than 4 inches

Skin weight (SK)

$$SK = \text{Shell (XFMB)} \quad \text{Shell} = \text{skin weight per inch}$$

$$\text{Total bay weight} = \text{expulsion system weight} + Sk + \text{Fuel controller} + Wt_{sp}$$

4.7 Inlet Sizing and Mass Properties

Determination of the inlet capture area is an integral part of ramjet sizing and performance and is discussed in Section 4.2 of this appendix. Inlet mass properties are discussed in Appendix C.

Inlet performance (pressure recovery, mass flow ratio, and additive drag as a function of Mach number and angle of attack) are supplied in tabular form and read into the SEATIDE CGSM.

4.8 Material and Mass Properties

4.8.1 Materials Subroutine MATLS

The MATLS module contains the yield and ultimate tensile strengths and densities for 11 different structural materials. Tensile strength data are stored as functions of temperature and have a maximum value over which the data are valid. Data for a given material are obtained by calling MATLS with a material code and desired temperature. MATLS calculates ultimate and yield tensile strengths at the temperature supplied and also determines the density. If the temperature supplied exceeds the maximum temperature, material properties are calculated at the maximum temperature and a warning note is flagged. Material properties contained in MATLS were extracted from the CAMS routine.

Table IV below lists the material code, the material, and the maximum temperature.

TABLE IV
MATERIAL PROPERTIES

<u>Code Number</u>	<u>Material</u>	<u>Max. Temp. (°F)</u>
1	AISI 150 PSI Steel	1000
2	SISI 200 PSI Steel	1000
3	300 GR Maraging Steel	1000
4	17-4PH Stainless	900
5	2014-T6 Aluminum	600
6	AZ31B-0 Magnesium	600
7	6AL-4V Titanium	1000
8	RENE 41	1600
9	WC129Y Columbium	2700
10	Glass Fabric Epoxy Laminate	400
11	Filament Wound Glass Epoxy	500

4.8.2 Mass Properties Subroutines

Moment of inertias and center of gravities for individual components are calculated by breaking the component into standardized geometrical shapes and using the appropriate subroutine for each shape. The shape subroutine calculates the moment of inertia and center of gravity and returns these values to the calling routine which, in turn, sums all of the data and determines the overall component properties. Lists of the geometrical shapes assumed for mass property calculations are presented at the end of applicable component subroutine. The standardized geometrical shape subroutines are listed in Table V and are described in the following pages.

TABLE V

STANDARDIZED GEOMETRY MODULES

<u>Subroutine</u>	<u>Configuration</u>
ZSPRLL	Hemispherical Shell within a hole centered about the centerline
ZSPRSS	Hemispherical Solid with a hole centered about the centerline
ZELPSS	Semi-Ellipsoidal Solid with a hole centered about the centerline
ZELPLL	Semi-Ellipsoidal Shell with a hole centered about the centerline
ZCONHH	Truncated conical shell
ZCYLHH	Hollow cylinder
ZCYLLL	Cylindrical shell
ZELSPR	Properties of circular or elliptical segment (used by other geometrical shape subroutines)

4.8.2.1 Subroutine ZSPLL

This module computes the moment of inertia and center of gravity of a hemispherical shell with a hole centered about the axis of rotation, using the following methodology:

$$Wt_s = 2 \pi r^2 t \rho$$

$$XII_x = .41667 * Wt_s R$$

$$Z_s = R/2$$



ρ = density

It is assumed that the moment of inertia of the material which would have been in the hole is equal to a flat disk with radius r and thickness t and a weight equal to

$$Wt_{hole} = \rho t \text{ surf}$$

where surf is the surface area calculated by ZELSPR. The centroid is assumed to be located midway between the forward face and the aft edge of the curved surface

$$Z_{hole} = \frac{Y + t}{2}$$

$$XII_{hole} = \frac{W_{hole}}{12} (3r^2 + t^2)$$

$$ZCG = \frac{Wt_s (Z_s) - W_{hole} (R - Z_{hole})}{Wt_s - W_{hole}}$$

transfer of moment of inertia to C.G.

$$XII = XII_s - XII_{hole} + Wt_s (Z_s - ZCG)^2 - Wt_{hole} (R - Z_{hole} - ZCG)^2$$

4.8.2.2 Subroutine ZSPRSS

Moment of inertia and center of gravity of a solid hemisphere with a hole centered about the axis of rotation are computed by this module as follows:

$$Z_s = \frac{3}{8} R$$

$$Wt_s = \frac{2\pi}{3} R^3 \rho$$

$$XII_s = 0.26 Wt_s R$$



ρ = density

It is assumed that the moment of inertia of the center perforation will be equal to the moment of inertia of a solid cylinder of radius r with the length adjusted to provide a weight equal to the weight of the center perforation.

$$W_{seg} = \rho V_{seg}$$

V_{seg} = segment volume determined by ZELSPR

$$W_{hole} = W_{seg} + W_{cyl}$$

Y = segment height determined by ZELSPR

$$L = \frac{W_{hole}}{\pi r^2 \rho}$$

$$XII_{hole} = \frac{W_{hole}}{12} (3r^2 + L^2)$$

$$W_{cyl} = \pi r^2 \rho (H - Y)$$

$$X = \frac{Z_s Wt_s - W_{hole} L/2}{Wt_s - W_{hole}}$$

$$XII = XII_s - XII_{hole} + Wt_s (Z_s - Z)^2 - W_{hole} (L/2 - Z)^2$$

4.8.2.3 Subroutine ZELPSS

Moment of inertia and center of gravity of a semi-ellipsoidal solid with a hole centered about the axis of rotation are computed by this module as follows:

$$Wt_s = \frac{2}{3} R^2 H$$

$$XII_s = wt \left[\frac{R^2}{5} + \frac{19 H^2}{320} \right]$$

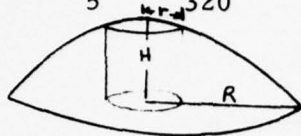

ρ = density

It is assumed that the moment of inertia of the center perforation will be equal to the moment of inertia of a solid cylinder of radius r with the length adjusted to provide a weight equal to the weight of the center perforation.

$$W_{seg} = \rho V_{seg}$$

V_{seg} = segment volume
determined by ZELSPR

$$W_{cyl} = \pi r^2 \rho (H - Y)$$

Y = segment height determined by ZELSPR

$$W_{hole} = W_{seg} + W_{cyl}$$

$$L = \frac{W_{hole}}{\pi r^2 \rho}$$

$$XII_{hole} = \frac{W_{hole}}{12} (3 r^2 t_L^2)$$

$$Z = \frac{Z_s Wt_s - W_{hole} L/2}{Wt_s - W_{hole}}$$

transfers of moment of inertia to C.G.

$$XII = XII_s - XII_{hole} + Wt_s (Z_s - Z)^2 - W_{hole} (L/2 - Z)^2$$

4.8.2.4 Subroutine ZELPLL

Moment of inertia and center of gravity of a semi-ellipsoidal shell with a hole centered about the axis of rotation are computed assuming that the moment of inertia of a semi-ellipsoidal shell will be equal to that of a solid semi-ellipsoid of dimensions H and R less the moment of inertia of a solid semi-ellipsoid of dimensions $H - t$ and $R - t$ where t is the thickness of the shell

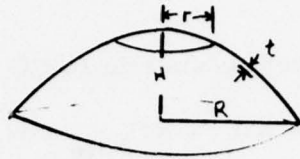

ρ = density

$$\text{weight}_s = \frac{2}{3} R^2 H$$

$$\text{XII}_s = \text{weight} \left[\frac{R^2}{5} + \frac{19H^2}{320} \right]$$

$$Z_s = \frac{3}{8} H$$

It is further assumed that the moment of inertia of the material which would have been in the hole is equal to a disk with a radius of r , a thickness t , and a weight equal to

$$\text{Wt}_{\text{hole}} = \rho t \text{ surf}$$

where surf is the surface area calculated by ZELSPR. The centroid is assumed to be located midway between the forward face and the aft edge of the curved surface

$$Z_{\text{hole}} = \frac{Y + t}{2}$$

$$\text{XII}_{\text{hole}} = \frac{W_{\text{hole}}}{12} (3r^2 + t^2)$$

$$\text{Semi-elliptical shell surface} = \pi \left[R^2 + \frac{H^2}{2F} \text{LOG}_e \left(\frac{1+F}{1-F} \right) \right]$$

$$\text{where } F = \frac{\sqrt{R^2 - H^2}}{R}$$

$$\text{Wt of shell} = (\text{surf area}) \rho t$$

Centroid

$$Z_{\text{shell}} = \frac{2\pi H (R^3 - H^3)}{3F^2 R (\text{surf area})}$$

Centroid of the shell with hole

$$Z = \frac{Z_{\text{shell}} (\text{wt of shell}) - \text{Wt}_{\text{hole}} (H - Z_{\text{hole}})}{\text{Wt of shell} - \text{Wt hole}} \quad \text{relative to ellipsoid base}$$

Transfer of moment of inertia to CG

$$\begin{aligned} XII = XII_s - XII_s' - XII_{hole} + W_s (Z_s - Z)^2 \\ - W_s' (Z_s' - Z)^2 - W_{hole} (Z_{hole} - Z)^2 \end{aligned}$$

4.8.2.5 Subroutine ZCONHH

Moment of inertia and center of gravity of a truncated conical shell are computed as

$$Z = \frac{H (2 R r)}{3 R r}$$

$$XII = \frac{W}{4} (R^2 + r^2) + \frac{W H^2}{18} \left(1 + \frac{2 r R}{r + R} \right)$$

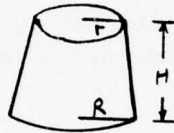

4.8.2.6 Subroutine ZCYLHH

Moment of inertia and center of gravity of a hollow cylinder are

$$Z = \frac{h}{2}$$

$$Z W = \left(\frac{H}{2} \right) wt$$

$$XII = \frac{Wt}{12} (3 (R^2 + R_H^2) + H^2)$$

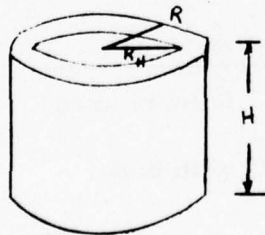

4.8.2.7 Subroutine ZCYLLL

Moment of inertia and center of gravity of a cylindrical shell are

$$Z = H/2$$

$$X_{II} = \frac{W}{2} \left(R^2 + \frac{H^2}{6} \right)$$

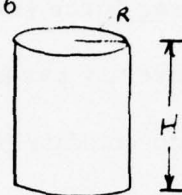

W is weight

4.8.2.8 Subroutine ZELSPR

Properties of a circular or elliptical segment are computed assuming that an elliptical segment is equivalent to a circular segment with the same segment radius (X) and height (Y). This assumption becomes increasingly inaccurate as $X \rightarrow R$.

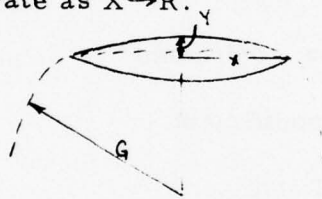

Oblate spheroid

H = ellipse minor axis

R = ellipse major axis

$$Y = H - H \sqrt{1 - \frac{X^2}{R^2}}$$

If sphere $G = R = H$

If ellipsoid

$$G = \frac{X^2 + Y^2}{2Y}$$

G is equivalent circular radius

$$\text{Volume} = \frac{\pi Y^2}{3} (3G - Y)$$

$$\text{Centroid } Z = \frac{3}{4} \frac{(2G - Y)^2}{(3G - Y)}$$

$$\text{Area} = 2\pi GY$$

TABLE V

RAMJET PROPULSION NOTATION

A	flow area (ft ²)
ALT	altitude (ft)
B	burner drag force (lb)
B _{SP}	burner severity parameter
c	local sonic velocity (ft/sec)
C _{DA}	inlet additive drag coefficient
C _{DB}	burner drag coefficient
C _{DC}	cowl drag coefficient
C _{NM}	nozzle mass flow coefficient
C _{FINT}	internal thrust coefficient
C _{FN}	net thrust coefficient
D _A	inlet additive drag (lb)
D _C	engine cowl drag (lb)
D _{EXT}	drag acting on the external surfaces of the engine (D _{EXT} = D _A + D _C)
f/a	combustor fuel to air weight ratio
F _{INT}	engine internal thrust (lb)
F _N	engine net thrust (lb)
g _o	gravitational acceleration (32.2 ft/sec ²)
l	fraction of inlet air which is extracted for accessory usage
M	Mach number

TABLE V (Continued)

P	static pressure (lb/ft ²)
P _T	stagnation or total pressure (lb/ft ²)
R	gas constant (ft/deg R)
\mathcal{R}	universal gas constant 1.98726 Btu/(mole ^o -R)
SFC	specific fuel consumption (lb fuel/lb thrust - hr))
ST	stream thrust (lb)
T	static temperature (deg R)
T _T	stagnation or total temperature (deg R)
T _{T4I}	ideal combustor exit stagnation temperature (deg R)
V	velocity (ft/sec)
W	weight flow rate (lb/sec)
W _A	air flow rate entering engine inlet (lb/sec)
W _b	boundary layer bleed flow rate (lb/sec)
W _f	engine fuel flow rate (lb/sec or lb/hr)
W _{max}	maximum airflow rate into the engine inlet for a given flight condition (lb/sec)

Greek Letters

α	angle of attack of the engine inlet with respect to the free stream flow direction (degrees)
γ	ratio of constant pressure and constant volume specific heats
δ	angle between the centerline of the engine and the direction of inlet boundary layer ejection from the engine
η_c	combustion temperature rise efficiency
η_N	nozzle thrust efficiency

TABLE V (Continued)

ρ	weight density (lb/ft ³)
Σ	summation sign
τ	shear stress (lb/ft ²)
<u>Subscripts</u>	
c	maximum possible area of the free stream tube of air which enters the engine
i	state corresponding to an isentropic expansion
x	axial component of force
o	free stream conditions
2	diffuser exit conditions
3	flow conditions aft of engine flame holders
4	nozzle entrance or combustor exit flow conditions
5	nozzle throat flow condition
6	nozzle exit plane flow condition

APPENDIX G
TURBOJET SIZING MODEL

TITLE TURBOJET SIZING MODEL	APPENDIX G
	NO. _____
	DATE _____

TABLE OF CONTENTS

<u>Section No.</u>		<u>Page No.</u>
1	INTRODUCTION	G-2
2	REFERENCES	G-2
3	SYSTEM DESCRIPTION	G-3
4	PERFORMANCE CALCULATION	G-6
5	TANKAGE	G-14
6	STRUCTURE	G-15
7	LIST OF SYMBOLS	G-16

LIST OF ILLUSTRATIONS

<u>Figure No.</u>		<u>Page No.</u>
1	TURBOJET GENERAL ARRANGEMENT	G-4
2	CRUISE MISSILE PAYLOAD	G-7
3	TURBOJET ENGINE SCHEMATIC DRAWING	G-8
4	COMPRESSOR MAP	G-10
5	TURBINE MAP	G-12

PREPARED BY Dr. J. A. Bottorff

PAGE G-1 OF G-17

APPROVED BY Dr. L. D. Gregory

APPENDIX G

TURBOJET SIZING MODEL

1. INTRODUCTION

(U) The purpose of this appendix is to present the methods used to calculate the performance, size, and mass properties of turbojet powered cruise missiles. The requirements include a single-spool, non-afterburning turbojet engine capable of operating over a Mach number range of 0 to 2.5 at altitudes from sea level to 50,000 feet. The air induction system for the turbojet powered cruise missiles is a two-dimensional belly mounted inlet. Either normal shock inlets or external compression inlets may be used within the model. Engine installation, fuel tank arrangements, and structural weight computations are described in the following sections.

2. REFERENCES

(U) References used in preparing the submodel are listed below:

<u>No.</u>	<u>Title</u>
1	Koenig, Robert W. and Fishbach, Lawrence H., "Geneng - A Program for Calculating Design and Off-Design Performance for Turbojet and Turbofan Engines," NASA TN D-6552, Lewis Research Center, February 1972.
2	Gerend, Robert P., and Roundhill, John P., "Correlation of Gas Turbine Engine Weights and Dimensions," AIAA Paper No. 70-669, AIAA Joint Specialists Conference, San Diego, California, June 15-19, 1970.

3. SYSTEM DESCRIPTION

(U) The turbojet powered cruise missile consists of two major sections, the payload section which includes the guidance and control equipment and warhead, and the propulsion section which includes the turbojet engine and accessories, portions of the air induction system, and the fuel tanks. Figure 1 illustrates the general internal arrangement of the turbojet powered cruise missiles. The turbojet powered cruise missiles may be sized to a specified weight only. The option of sizing to a given length is not available in the turbojet sizing submodel. Fuel tank length is defined by the weight allowance for fuel and tankage after subtracting the other vehicle component weights from the total system weight. The length of the cylindrical portion of the fuel tank is computed from the following equation for the wedge tank option.

$$XCYL = \frac{(WTTJ - WSUM - WSH - WWT - RHOF \times VOLHD - VOLWT \times RHOF)}{(.7854 \times DTANK^2 + PI \times DTANK \times TC \times RHOMTL)}$$

where

$$WSUM = WPL + WASURF + WMISTJ + WENG + WING +WSTRPS + WFS$$

Tank length is defined by the length of the wedge portion, the tank cylindrical length, and the length of the forward head. Propulsion system length is defined by the engine length, tank length, miscellaneous length, and the length of the constant area section of the diffuser duct at the engine forward face.

$$XLPS = XENG + DFTIP + XLTW + XCYL + XLFH + XLMISC$$

Total length of the turbojet powered configuration is the sum of the lengths of the payload section and the propulsion section

$$XTOTAL = XLPAY + XLPS$$

FIGURE 1. TURBOJET GENERAL ARRANGEMENT (U)

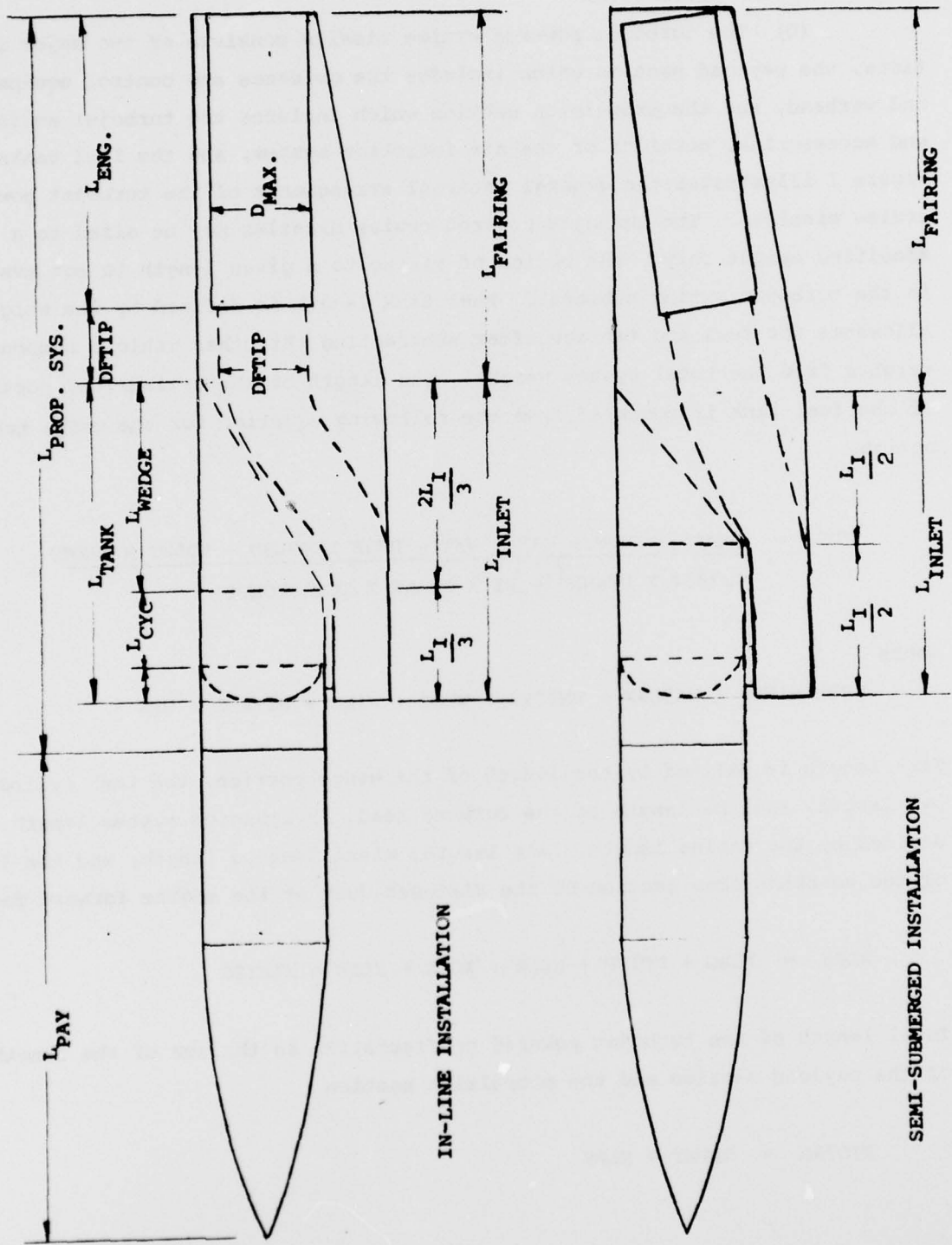

(U) The turbojet engine may be mounted along the centerline of the missile or a semi-submerged installation may be used where the forward face of the engine is offset below the missile centerline. The maximum offset will not exceed the maximum dimension set by the depth of the inlet housing. Two fuel tank options are available; a cylindrical tank with ellipsoidal heads, or a cylindrical tank with a forward ellipsoidal head and a wedge shaped tank fitted above the inlet diffuser duct. Diffuser duct length may be defined by the size of the engine and inlet capture area or it may be supplied as an input item. Fuel tank lengths are a function of the inlet diffuser length and the type of engine installation.

(U) The air induction system for the turbojet powered cruise missiles consists of a two-dimensional belly mounted inlet, a vertical wedge boundary layer diverter, and a diffuser duct with an equivalent 7 degree expansion. A constant area section equal in length to one engine face diameter is allowed at the compressor inlet. As an alternative, diffuser duct length may be input. The forward section of the inlet is mounted on a boundary layer diverter wedge attached to the missile at the lower centerline. A gentle "S" bend is required in the diffuser duct to obtain low distortion levels at the engine face.

(U) Two inlet designs are available for the turbojet powered cruise missiles; normal shock inlets for cruise Mach number of 1.5 or less and a single external compression surface inlet for cruise Mach number greater than 1.5. The ramp angle for the external compression inlets may be varied between 8 and 16.5 degrees by input inlet performance data tables. A more detailed description of inlet sizing is presented in Appendix E.

3.1 Payload Section

(U) The payload section consists of the missile nose and cylindrical section forward of the fuel tanks. Payload length is a Basic Variable input while payload weight is the sum of warhead weight, guidance and equipment weight, any miscellaneous weight in the payload section, and the weight of the structural skin in the payload section. Warhead and guidance weight are Basic

Variable inputs, the miscellaneous weight is an input item, and the payload structural weight may be input or computed from the total skin area and either an input unit weight, or an input skin thickness and material density. Figure 2 shows the payload general arrangement for all of the cruise missile configurations.

3.2 Engine Description

(U) The turbojet engine is a single-spool type with a converging nozzle and no afterburning. Compressor bleed air is provided for turbine cooling and power may be extracted from the turbine for driving accessories. The engine operates on JP-type fuel although other types of fuels could be used without a major modification to the program. Figure 3 is a schematic drawing of the engine showing station locations. The engine performance and weight are calculated using two separate computer routines described in the following paragraphs.

4. PERFORMANCE CALCULATION

(U) The engine performance is calculated using the General Engine (GENENG) Computer Routine developed by NASA/LRC (Reference 1). This routine provides the capability of calculating the design and off-design performance of single and double-spool turbojet engines as well as turbofan engines.

(U) The turbojet engine airflow requirements are defined by the thrust requirement and the design point flight conditions (Mach number, altitude). Inlet capture area is sized to satisfy the engine airflow requirements at the design point.

(U) Pertinent features of the GENENG routine are discussed below.

4.1 Design Point

(U) Engine performance characteristics at the design point are calculated using the following input parameters:

ZFDS	Position on a speed line
PRFDS	Compressor pressure ratio
WAFCDs	Corrected airflow

FIGURE 2. CRUISE MISSILE PAYLOAD (U)

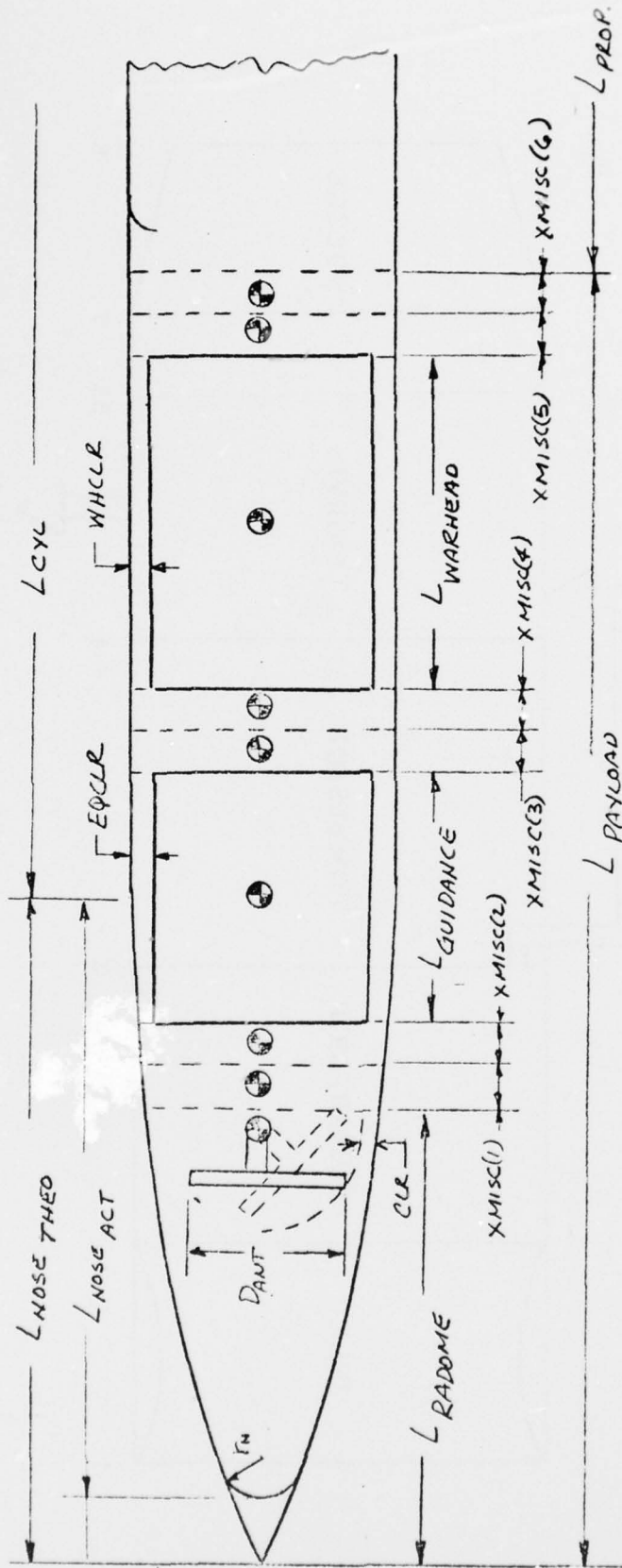

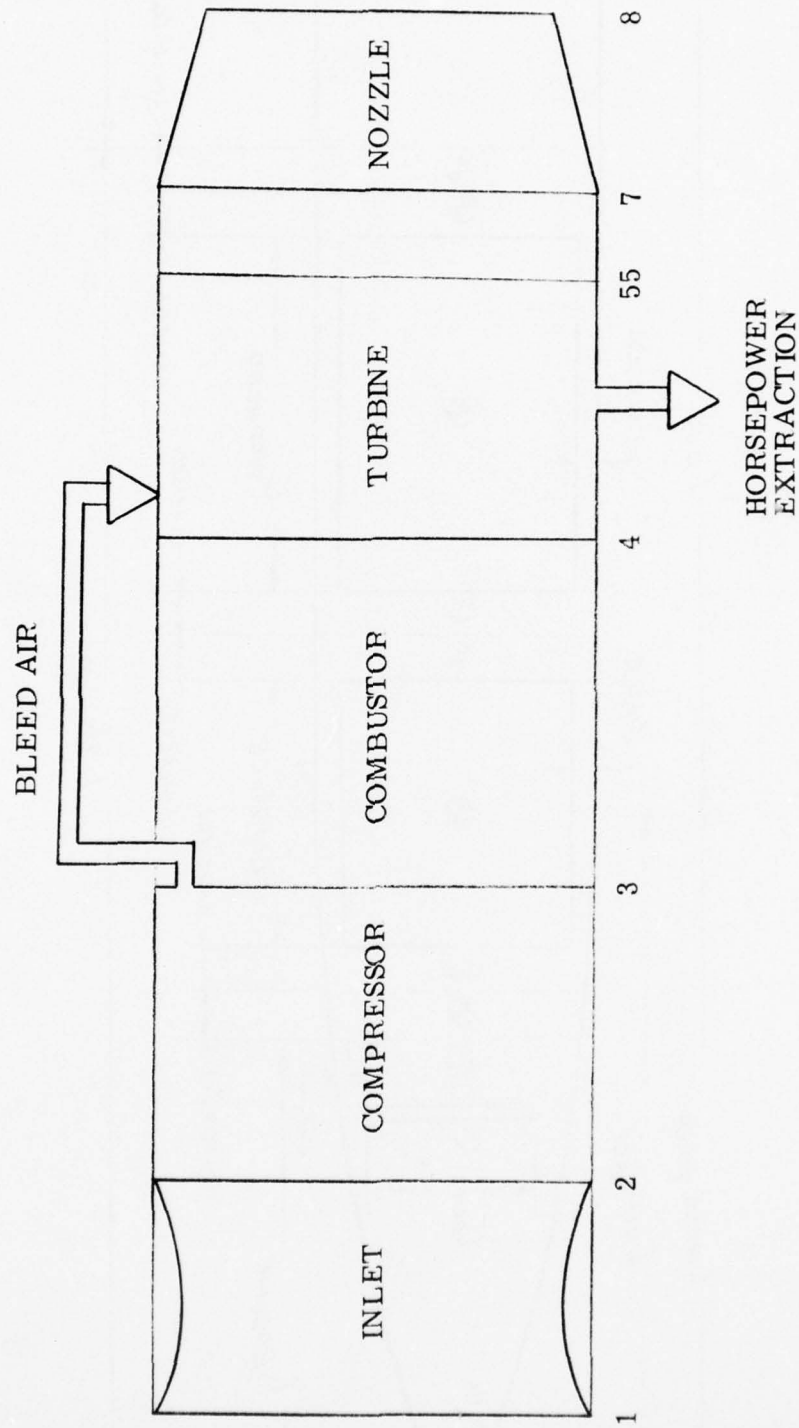

FIGURE 3 TURBOJET ENGINE SCHEMATIC DRAWING

ETAFDS	Compressor Efficiency
PCNFDS	Percent of Maximum RPM
PCBLC	Percent airflow used for turbine cooling
DPCODS	Combustor pressure drop
ETABDS	Combustor efficiency
ETLPDS	Turbine efficiency
TFLDDS	Turbine flow function
CNLPDS	Turbine Corrected Speed
A55	Turbine Outlet Mach Number
ALTP	Altitude
AM	Vehicle Flight Mach Number
T4DS	Turbine Inlet Temperature

4.2 Off-Design Point

(U) For off-design performance, the GENENG routine uses performance maps for the compressor, combustor, turbine and nozzle. These maps are input as block data. To calculate performance at an off-design point, the following conditions must be specified:

ALTP	Altitude
AM	Flight Mach Number
T4	Turbine Inlet Temperature

With this information and previously calculated design parameters, the component maps are used to achieve an engine balance at the off-design point.

4.3 Component Maps

(U) The original GENENG Routine contains performance maps which are typical maps which were generated by the authors of the routine for illustrating its use. Although these maps were not prepared from any existing engine data, it has been found that the maps are not dissimilar to maps on existing US engines. Because of this, and due to the fact that the GENENG maps have been well checked out, it was decided to continue to use those component maps.

(U) The GENENG compressor map is shown in Figure 4. The low range of pressure ratios results from the fact that the map is used for the fan for turbofan engine calculations and is used for the compressor for turbojet

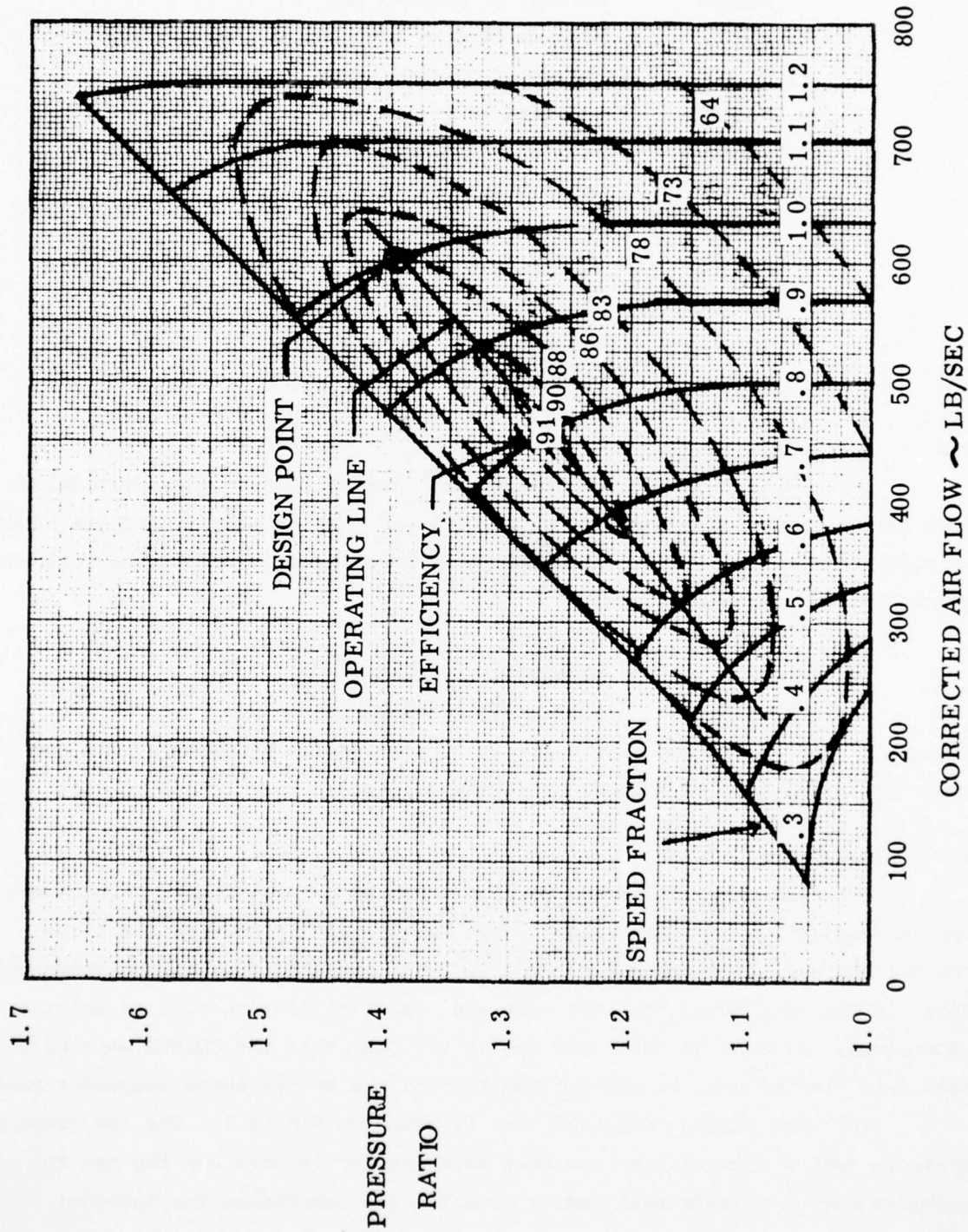

FIGURE 4 TURBOJET COMPRESSOR MAP

calculations. For use in any case, the input design point values for pressure ratio, corrected airflow and efficiencies are used to create scaling factors which the routine uses to create new maps for the correct range of variables. For instance, the equation which exists in GENENG for converting existing map values of pressure ratios to values for the new map is:

$$\text{PRFCF} = \frac{\text{PRDS}-1}{\text{PRMDS}-1}$$

where PRFCF = map conversion factor
PRDS = design point pressure ratio for case being run
PRMDS = design point pressure ratio in GENENG map

(U) As an example, suppose it is desired to investigate an engine having a compressor pressure ratio of 8.0. Since the existing GENENG map has a design pressure ratio of 1.4, the correction factor becomes

$$\text{PRFCF} = \frac{8-1}{1.4-1} = \frac{7}{0.4} = 17.5$$

Hence, all values for pressure ratio in the block data table are multiplied by 17.5 to set up a new block data table having the proper pressure ratio range. Similar correction factors are calculated for converting the other parameters in the block data table. A similar procedure is used to create new turbine, combustor and nozzle maps. The GENENG turbine map is shown in Figure 5.

4.4 Output Data

(U) In addition to the major parameters, net thrust, fuel flow and specific fuel consumption, the routine has the capability of printing out a number of other parameters including the following:

PCNF	Percent compressor speed
ZF	Position on a speed line
PRF	Compressor pressure ratio
W AFC	Corrected airflow

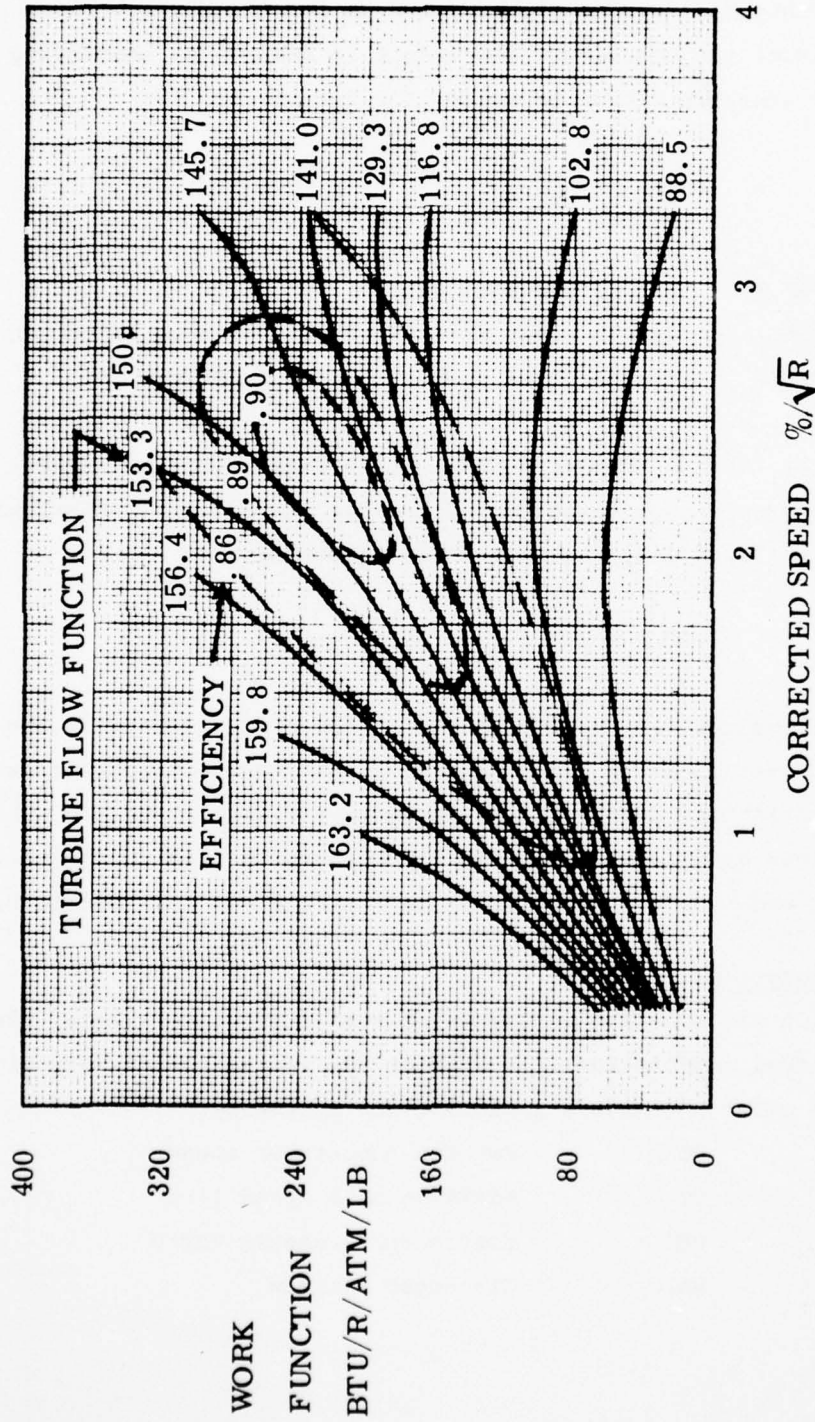

FIGURE 5 TURBOJET TURBINE MAP

WAF	Airflow
TFFLP	Turbine flow function
CNLP	Turbine temperature corrected speed
DHTCLP	Turbine temperature corrected enthalpy drop
T,P,H,S	Temperatures, pressures, enthalpies and entropies at all stations

(U) The engine weight is calculated using LTV's WATE computer routine. This routine was developed from Reference 2. The weight calculation uses an initial base engine weight which is determined by the engine airflow rate. This base weight is then modified by correction factors related to engine IOC date and design factors such as pressure ratio, turbine inlet temperature and flight Mach number. The input factors to the routine and their ranges in values are listed below:

LIFE	Engine life - short, medium or long
NMAX	Maximum Mach number - 0 to 3
OPR	Compressor pressure ratio - 4 to 35
TIT	Turbine inlet temperature
WO	Total airflow rate
YEAR	Year of IOC - 1945 to 1985

(U) In addition to engine weight, length and diameter, the WATE routine provides the following listed information:

DIT	Turbine tip diameter
DRF	Rear flange diameter
DFF	Front flange diameter
DFTIP	Compressor tip diameter

Also, scaling factors are printed out which allow engine scaling over a modest range.

5. TANKAGE

(U) The general configuration of the fuel tank is shown in Figure 1 for partially submerged and fully submerged engine configurations. The only difference in the tanks for the two engine configurations is that for the partially submerged engine, the tank can extend farther aft than the fully submerged engine.

(U) An option exists for selecting aluminum, stainless steel or titanium for the tank material. The tank wall thickness is calculated on the basis of expected bending loads and the particular material modulus of elasticity as was done for the liquid engine tankage. A minimum wall thickness of 0.03 inches is allowed. Tank heads are ellipsoidal shells having an ellipse ratio of 2:1 and the same thickness as the tank side wall. Material density, wall thickness and surface area are used to calculate tank weight. An option is also available for inputting a weight per unit tank surface area as shown in Figure 1. The tank consists of a wedge shape portion and, where length or weight permits, an additional cylindrical portion. The wedge-shape portion of the tank is formed by a plane surface cutting a cylinder diagonally as shown in Figure 1. The length (and ultimately the volume) of the wedge-shape portion of the tank is determined solely by the length of the inlet. For the partially submerged engine inlet, the wedge-shape portion of the tank is two-thirds of the inlet length. For the fully submerged engine, the wedge portion is one-half the inlet length. Where missile length or weight is sufficient, the tankage extends forward of the wedge-shape portion in the form of a cylindrical-shape tank. It should be noted that in all cases, for both the length and the weight options, tankage must consist of at least the wedge-shape portion having a length equal to a fraction ($2/3$ or $1/2$) of the inlet length. As a result, there could be a situation in a weight-option problem, where after the weight of the tank is accounted for, there is insufficient weight remaining to fill the tank with fuel. In such a case, the configuration is flown with a partially filled tank.

6. STRUCTURE

(U) Structural weight in the turbojet propulsion system consists of the weight of the structural skin around the engine and diffuser duct, part of the skin around the wedge tank, and the skin around the miscellaneous section. Structural material may be aluminum, titanium, or steel. Skin thickness is estimated by the relation

$$TC = \frac{2.725 \times DTANK}{E^{0.4}}$$

where E is Young's Modulus of elasticity. The minimum skin thickness allowed is 0.03 inches. The skin area used in structural weight estimates is computed from the following relation

$$ASKINP = PI \times DCASE \times (XENG + DFTIP + \frac{XLTW}{2} + XLMISC)$$

Structural skin weight is then computed from the skin area, skin thickness, and material density.

$$WSTRPS = ASKINP \times TC \times RHOMTL \times KSTR$$

where KSTR is an adjustment factor to account for other miscellaneous structural items. Material properties used in the structural weight computation are presented in the following table.

<u>Material</u>	<u>Density - lb/in³</u>	<u>Young's Modulus - lb/in²</u>
Aluminum	0.1	10.47 x 10 ⁶
Titanium	0.167	15.89 x 10 ⁶
Steel	0.29	28.86 x 10 ⁶

(U) An alternate method of structural weight computation is based on the following

$$WSTRPS = ASKINP \times WOVAST \times KSTR$$

Where WOVAST is a structural unit weight. A third method of accounting for structural weight in the propulsion section consists of a user supplied input.

7. LIST OF SYMBOLS

<u>Item</u>	<u>Description</u>
DCASE	Missile diameter - in.
DFTIP	Engine diameter at compressor face - in.
DTANK	Fuel tank diameter - in.
E	Young's Modulus - psi
PI	3.14159
RHOF	Fuel density - lb/ft ³
RHOMTL	Tank material density - lb/in ³
TC	Tank wall thickness - in
VOLHD	Volume of an ellipsoidal head - in ³
VOLWT	Volume of a wedge shaped tank - in ³
WASURF	Weight of all aerodynamic surfaces - lbs.
WENG	Turbojet engine weight - lbs.
WFS	Forward skirt weight - lbs.
WINL	Air induction system weight - lbs.
WOVAST	Structural unit weight - lb/in ²
WMISTJ	Miscellaneous weight in propulsion section - lbs.
WPL	Payload weight - lbs.
WSH	Structural weight of ellipsoidal head - lbs.
WSTRPS	Structural weight in propulsion system - lbs.
WTTJ	Launch weight of turbojet missile- lbs.
WWT	Weight of wedge-shaped tank - lbs.

U

<u>Item</u>	<u>Description</u>
XCYL	Tank cylindrical section length - in.
XENG	Engine length - in.
XLFH	Length of forward head - in.
XMISC	Miscellaneous section length - in.
XPAY	Payload length - in.
XLPS	Propulsion system length, in.
XLTW	Length of wedge tank - in.
XTOTAL	Missile overall length - in.