

AD-A048 312

ARMY ENGINEER WATERWAYS EXPERIMENT STATION VICKSBURG MISS F/6 11/2
IDENTIFICATION OF ALTERNATIVE POWER SOURCES FOR DREDGED MATERIA--ETC(U)
NOV 77 C E PARKER, D PAL, K F VODRASKA

UNCLASSIFIED

WES-TR-D-77-32

NL

1 of 2
ADA048312



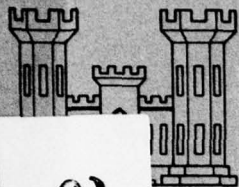

DREDGED MATERIAL RESEARCH PROGRAM



14 WES-TR-
TECHNICAL REPORT D-77-32

AD A 048312

IDENTIFICATION OF ALTERNATIVE POWER SOURCES FOR DREDGED MATERIAL PROCESSING OPERATIONS.

by

10 C. E. Parker, D. Pal, K. F. Vodraska, J. B. Ciani

Civil Engineering Laboratory
Naval Construction Battalion Center
Port Hueneme, Calif. 93043

11 Nov 1977
9 Final Report

Approved For Public Release; Distribution Unlimited

12136 p.

DDC
JAN 12 1978

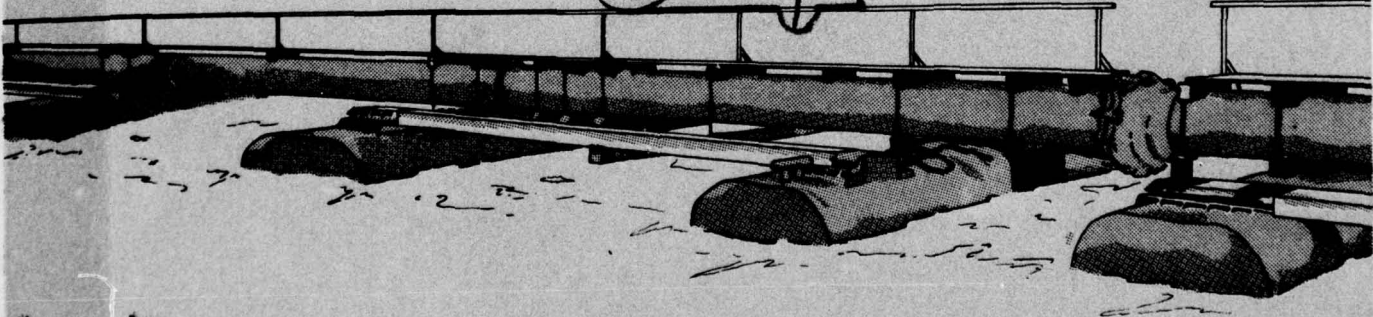

AD NO. _____
DDC FILE COPY

Prepared for Office, Chief of Engineers, U. S. Army
Washington, D. C. 20314

Under DMRP Work Unit No. 5C08

Monitored by Environmental Effects Laboratory
U. S. Army Engineer Waterways Experiment Station
P. O. Box 631, Vicksburg, Miss. 39180

038 100

mt

Destroy this report when no longer needed. Do not return
it to the originator.



DEPARTMENT OF THE ARMY
WATERWAYS EXPERIMENT STATION, CORPS OF ENGINEERS
P. O. BOX 631
VICKSBURG, MISSISSIPPI 39180

IN REPLY REFER TO: WESYV

25 November 1977

SUBJECT: Transmittal of Technical Report D-77-32

TO: All Report Recipients

1. The report transmitted herewith represents the results of a research effort (work unit) initiated as part of Task 5C (Disposal Area Reuse Research) of the Corps of Engineers' Dredged Material Research Program (DMRP). Task 5C is included under the Disposal Operations Project, which is concerned with both the environmental effects of disposal operations and facilities as well as new concepts for disposal, particularly those concepts involving consideration of dredged material as a resource rather than simply a waste product.
2. A particularly attractive concept for mitigating the land requirements for disposal sites is to increase the life expectancy of sites through the periodic removal of dredged material for use elsewhere. Optimally, sites could be used indefinitely and be truly permanent disposal facilities. However, continuing needs for the dredged material must be identified; procedures must be identified for processing and/or rehandling materials; and mechanisms must be established for marketing materials under known constraints.
3. The investigation reported herein addresses identification of power sources for processing systems at reusable disposal sites. Processing systems at disposal sites may be designed to extract sand and gravel for commercial use, remove silt and clay from water to meet effluent-quality restrictions, and dewater residual silt and clay to reduce volume and/or provide a more desirable material. Conventional power may not be available or may be extremely expensive due to the remoteness and inaccessibility of many of the disposal sites; consequently, alternative power sources were investigated for the DMRP by the Civil Engineering Laboratory, Naval Construction Battalion Center, Port Hueneme, California.
4. The scope of the assigned task was to provide a screening and selection procedure for designing power sources for dredged material processing systems. No original research was conducted as part of this study, and conclusions were drawn based on existing information. The exact power requirements for reusable disposal sites are unknown because

WESYV

25 November 1977

SUBJECT: Transmittal of Technical Report D-77-32

this study was made concurrently with studies to provide guidance on the design of such facilities. However, the range of magnitude of power available from alternative sources was determined and could be fitted to the power requirements later.

5. Wind, solar, and hydraulic power sources were considered in the study. Results indicated that even though flat-plate solar collectors are now commercially available to heat air or water for buildings, they are not well adapted to known dredged material processing systems requirements. Solar cell electrical power generation, though available, is not cost competitive in its application at present. Likewise, hydraulic power generation by waves, currents, or small hydroelectric plants does not appear to be practical at typical dredging sites. Of all the alternative power sources studied, wind electric generation seemed to be the most practical and versatile.
6. Though the unit cost of wind-produced electricity is competitive, the present generator size limit of 12 kw might require a large number of wind-powered generators at a dredging site. For example, if windmills were used to power dewatering devices such as vacuum pumping or electro-osmosis systems, approximately one 12-kw wind-powered generator would be needed for each acre. However, larger 100-kw wind-powered generators are now under operational tests. A typical 100-acre disposal site could be dewatered by devices operated by twelve 100-kw generators.
7. The results of this study will be included as part of a synthesis report on the concept of reusable disposal sites. Of course, the results are also applicable to any situation where power may be required at a disposal site.

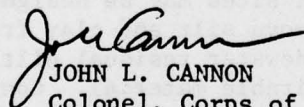

JOHN L. CANNON
Colonel, Corps of Engineers
Commander and Director

Unclassified

SECURITY CLASSIFICATION OF THIS PAGE (When Data Entered)

REPORT DOCUMENTATION PAGE		READ INSTRUCTIONS BEFORE COMPLETING FORM
1. REPORT NUMBER Technical Report D-77-32 ✓	2. GOVT ACCESSION NO.	3. RECIPIENT'S CATALOG NUMBER
4. TITLE (and Subtitle) IDENTIFICATION OF ALTERNATIVE POWER SOURCES FOR DREDGED MATERIAL PROCESSING OPERATIONS	5. TYPE OF REPORT & PERIOD COVERED Final report	
	6. PERFORMING ORG. REPORT NUMBER	
7. AUTHOR(s) C. E. Parker D. Pal K. F. Vodraska J. B. Ciani	8. CONTRACT OR GRANT NUMBER(s)	
9. PERFORMING ORGANIZATION NAME AND ADDRESS Civil Engineering Laboratory ✓ Naval Construction Battalion Center Port Hueneme, California 93043	10. PROGRAM ELEMENT, PROJECT, TASK AREA & WORK UNIT NUMBERS DMRP Work Unit No. 5C08	
11. CONTROLLING OFFICE NAME AND ADDRESS Office, Chief of Engineers, U. S. Army Washington, D. C. 20314	12. REPORT DATE November 1977	
	13. NUMBER OF PAGES 138	
14. MONITORING AGENCY NAME & ADDRESS (if different from Controlling Office) U. S. Army Engineer Waterways Experiment Station Environmental Effects Laboratory P. O. Box 631, Vicksburg, Mississippi 39180	15. SECURITY CLASS. (of this report) Unclassified	
	15a. DECLASSIFICATION/DOWNGRADING SCHEDULE	
16. DISTRIBUTION STATEMENT (of this Report) Approved for public release; distribution unlimited.		
17. DISTRIBUTION STATEMENT (of the abstract entered in Block 20, if different from Report)		
18. SUPPLEMENTARY NOTES		
19. KEY WORDS (Continue on reverse side if necessary and identify by block number) Alternate energy sources Dredged material disposal Hydraulic power Solar energy conversion Wind power		
20. ABSTRACT (Continue on reverse side if necessary and identify by block number) This report provides a basis for selecting alternative, renewable power sources specifically for operating dredged material processing systems. A dredged material processing system is designed to: (1) extract sand and gravel for commercial use, (2) remove silt and clay from water to meet quality restrictions on return water, and (3) dewater the residual silt and clay to reduce volume and provide a usable foundation for later land use. Currently, processing of dredged material usually consists of holding the hydraulically pumped slurry in a diked containment area and pumping or draining off the water after settlement of the suspended material. Subsequent natural drying by sun and wind presents a problem if the material is a fine-grained silt or clay. ↓ (Continued)		

20. ABSTRACT (Continued).

The scope of the assigned task was to provide a screening and selection procedure for the engineer designing a dredged material processing system in order to decide which natural form of energy (or combination) if any, should be chosen to power the system. Power requirements of the mechanical gravel and sand separators would be established when specific equipment is selected for a particular system. Mobile equipment for dredged material processing might be powered from the alternative sources; for example, electric motors could operate on batteries charged by the alternative sources.

The exact power requirements to dewater the fine-grained fractions are unknown because dewatering equipment is presently under development, but alternative power can be provided in several forms. The following were considered in this study: (1) Wind power, driving pumps and electric generators, (2) Solar radiation converted to thermal and electrical energy, and (3) Hydraulic power (waves and currents) for driving electric generators. Some consideration was given to obtaining power from solid waste (such as incineration of trash), but was discarded, as not pertinent to the scope of this report.

Even though flatplate solar collectors are now commercially available to heat air or water for buildings, they are not well adapted to known dredged material processing systems. Solar cell electrical power generation, though available, is not cost competitive in this application at present. Likewise, hydraulic power generation by waves, currents, or small hydroelectric plants does not appear to be practical at typical dredging sites.

Of all the alternative power sources studied, wind electric generation seems to be the most practical and versatile to apply at this time. A 12-kw DC wind generator is shown to provide power at Buffalo, New York (best site), for \$0.0243/kw-hr, a price actually less than the typical purchased electricity cost of \$0.0263/kw-hr. Electrical power could be used by the vacuum pumping and electro-osmotic dewatering systems presently under development elsewhere. Though the unit cost of wind-produced electricity is competitive, the present size limit of 12 kw might imply a large number of wind generators at dredging sites. Such a situation may be deemed impractical at this time.

With an estimate of 0.15 kw-hr to be required to remove 1 gallon of water from dredged material by electro-osmosis, the 12-kw wind generator could provide energy to dewater over 2500 cu yd of dredged material in a year at favorable locations. The energy cost for this processing would be \$0.18/cu yd. Vacuum well-point pumping is also being tested by other Dredged Material Research Program investigators using wind-generator power. While approximately one 12-kw wind generator would be needed for each acre, several facts should be considered: (1) Purchased electricity costs are rising rapidly, (2) Bringing electrical powerlines to remote sites is costly, (3) Larger 100-kw wind generators are now under operational test, (4) Removal of water from fine-grained dredged material by any method requires considerable energy, and (5) Wind generators can be transported between sites. A typical 100-acre disposal site might be powered by twelve 100-kw wind generators under the above assumptions, thus dewatering 250,000 cu yd/yr. Spacing the generators at two diameters apart on a line facing the prevailing wind implies an array about 1/2 mile long.

ACCESSION for	W	✓
NTIS	B	✓
DDC		✓
UNANNOUNCED		✓
151104 124		✓
added: JAP		
RESERVED FOR/ANALYSIS/NOTES		
SPECIAL		
A		

THE CONTENTS OF THIS REPORT ARE NOT TO BE
USED FOR ADVERTISING, PUBLICATION, OR
PROMOTIONAL PURPOSES. CITATION OF TRADE
NAMES DOES NOT CONSTITUTE AN OFFICIAL EN-
DORSEMENT OR APPROVAL OF THE USE OF SUCH
COMMERCIAL PRODUCTS.

EXECUTIVE SUMMARY

This report provides a basis for selecting alternative, renewable power sources specifically for operating dredged material processing systems.

A dredged material processing system is designed to: (1) extract sand and gravel for commercial use, (2) remove silt and clay from water to meet quality restrictions on return water, and (3) dewater the residual silt and clay to reduce volume and/or provide a usable foundation for later land use. Currently, processing of dredged material usually consists of holding the hydraulically pumped slurry in a diked containment area and draining off the water after settlement of the suspended material. Subsequent natural drying by evaporation may not significantly reduce the water content of silts and clays for long periods of time (years).

The scope of the assigned task was to provide a screening and selection procedure for the engineer designing a dredged material processing system in order to decide which natural form of energy (or combination), if any, should be chosen to power the system. Power requirements of the mechanical gravel and sand separators would be established when specific equipment is selected for a particular system. Mobile equipment for dredged material processing might be powered from the alternative sources; for example, electric motors could operate on batteries charged by the alternative sources.

The exact power requirements to dewater the fine-grained fractions are unknown because dewatering equipment is presently under development, but alternative power can be provided in several forms. The following were considered in this study:

1. Wind power for driving pumps and electric generators
2. Solar radiation for conversion to thermal and electrical energy
3. Hydraulic power (waves and currents) for driving electric generators.

Some consideration was given to obtaining power from solid waste (such as incineration of trash), but the idea was discarded as not pertinent to the scope of this report. In this report, wind power is presented as

electricity or as shaft horsepower, solar power as heated water or air flow or as electricity, and hydraulic power, possibly, as electricity.

Even though flatplate solar collectors are now commercially available to heat air or water for buildings, they are not well adapted to known or proposed dredged material processing systems. The cost of solar cell electrical power generation, though available, is prohibitively high at present. Likewise, hydraulic power generation by waves, currents, or small hydro-electric plants does not appear to be practical at typical dredging sites.

Of all the alternative power sources studied, wind electric generation seems to be the most practical and versatile to apply at this time. A 12-kw DC wind generator is shown to provide power at Buffalo, New York (best site), for \$0.0243/kw-hr, a price actually less than the typical purchased electricity cost of \$0.0263/kw-hr. Electrical power could be used by the vacuum pumping and electro-osmotic dewatering systems presently under development elsewhere. However, though the unit cost of wind-produced electricity is competitive, the present size limit of 12 kw might imply a large number of wind generators at dredging sites. Such a situation may be deemed impractical at this time.

With an estimate of 0.15 kw-hr to be required to remove 1 gal of water from dredged material by electro-osmosis, the 12-kw wind generator could provide energy to dewater over 2500 cu yd of dredged material in a year at favorable locations. The energy cost for this processing would be \$0.18/cu yd. Vacuum well-point pumping is also being tested by other Dredged Material Research Program investigators using wind-generator power. While approximately one 12-kw wind generator would be needed for each acre, several facts should be considered: (1) purchased electricity costs are rising rapidly, (2) bringing electrical powerlines to remote sites is costly, (3) larger 100-kw wind generators are now under operational test, (4) removal of water from fine-grained dredged material by any method requires considerable energy, and (5) wind generators can be transported between sites. A 100-acre disposal site might be powered by twelve 100-kw wind generators under the above assumptions, thus dewatering 250,000 cu yd/yr. Spacing the generators at two propeller diameters

apart on a line facing the prevailing wind implies an array about one-half mile long.

PREFACE

This report documents work performed by the Civil Engineering Laboratory (CEL), Naval Construction Battalion Center, Port Hueneme, California, as part of the Corps of Engineers Dredged Material Research Program (DMRP). The DMRP is sponsored by the Office, Chief of Engineers (DAEN-CWO-M), and is administered by the Environmental Effects Laboratory (EEL), U. S. Army Engineer Waterways Experiment Station (WES), Vicksburg, Mississippi.

The study was conducted under Task 5C of the DMRP, "Disposal Area Reuse," Work Unit No. 5C08, "Identification of Alternative Power Sources for Dredged Material Disposal Operations," and was performed during the period from June 1975 through June 1976. The report is the result of research to identify, describe, and evaluate presently available or potential systems for converting available resources located in the vicinity of dredging and disposal sites to usable energy for operation of equipment. Both technical and economic feasibility of different power generation systems is considered.

The principal investigator at CEL was C. E. Parker of the Energy Program Office, and the associate investigator was J. B. Ciani. Coauthors of this report were D. Pal and K. F. Vodraska. Others who contributed to this work were F. W. Herrmann, R. E. Kirts, and H. S. Zwibel. The figures were drawn by R. S. Eldridge and D. J. Erwin. The report was edited by V. N. Spafford.

The study was managed by Alfred W. Ford, EEL, for Charles C. Calhoun, Jr., Manager of the Disposal Operations Project, DMRP. The study was under the general supervision of Dr. John Harrison, Chief, EEL.

The directors of WES during the period of investigation and preparation of the report were COL G. H. Hilt, CE, and COL J. L. Cannon, CE. The Technical Director was Mr. F. R. Brown.

CONTENTS

	<u>Page</u>
EXECUTIVE SUMMARY	1
PREFACE	4
LIST OF FIGURES	7
LIST OF TABLES	10
CONVERSION FACTORS, U.S. CUSTOMARY TO METRIC (SI) UNITS OF MEASUREMENT	11
PART I: INTRODUCTION	13
Background	13
Purpose	14
Scope	14
PART II: APPROACH	15
General	15
Study Functions	15
Methodologies	16
Data Sources	16
Computations	17
Cost Benefits	18
Presentation	19
PART III: POWER SOURCES	21
Wind Power	21
Solar Radiation	23
Hydraulic Power	27
PART IV: REGIONAL ASSESSMENT OF POWER SOURCES	33
Wind Power	33
Solar Radiation	34
Hydraulic Power	35
PART V: CONCLUSIONS AND RECOMMENDATIONS	38
Conclusions	38
Recommendations	40
REFERENCES	42

CONTENTS

	<u>Page</u>
APPENDIX A:* WIND POWER ANALYSIS METHODOLOGIES AND CONVERSION SYSTEMS	A1
APPENDIX B: SOLAR ENERGY CONVERSION PROCESSES	B1
APPENDIX C: HYDRAULIC POWER ANALYSIS METHODOLOGIES AND CONVERSION SYSTEMS	C1
APPENDIX D: DATA AND POWER POTENTIAL FOR SELECTED LOCATIONS	D1
APPENDIX E: INFORMATION SOURCES	E1
APPENDIX F: NOTATION	F1

* Appendixes A-E were reproduced on microfiche and are included in an envelope attached inside the back cover of this report.

LIST OF FIGURES

<u>No.</u>		<u>Page</u>
1	Aeromotor 6-hp, wind-driven water-pumping unit with a rotor diameter of 16 feet	44
2	Elektro 12-kw DC wind generator installation near Wintertzur, Switzerland. The wind machine has a propeller 21 feet 6 inches in diameter	45
3	Windspeed and power duration curves for a site near Buffalo	46
4	Windspeed and power duration curves for a site near Galveston	47
5	Windspeed and power duration curves for a site near Norfolk	48
6	Windspeed and power duration curves for a site near Philadelphia	49
7	Windspeed and power duration curves for a site near Savannah	50
8	Windspeed and power duration curves for a site near Mobile	51
9	Windspeed and power duration curves for a site near Detroit	52
10	Windspeed and power duration curves for a site near Portland	53
11	Windspeed and power duration curves for a site near Seattle (Tacoma Airport)	54
12	Daily average of annual available solar energy	55
A1	Power coefficient $C_p(V)$ versus windspeed V for the 5-kw wind generator	A8
A2	Operating a 3-phase AC wind generator with an automatic switching device for electro-osmotic dewatering	A9
A3	Characteristics of 5-kw electro wind generator and switching system for optimal usage of wind energy	A10

<u>No.</u>		<u>Page</u>
A4	Sharing wind-generated power with commercial power for continuous electro-osmotic dewatering	A11
A5	Method of using wind-generated power with grid power for pumping water at constant speed	A12
A6	Windmill-driven diaphragm pump system for dredged material dewatering	A13
B1	Typical solar-chemical energy conversion process	B6
B2	Typical solar-thermal energy conversion process	B6
B3	Typical solar-thermal-electric energy conversion process	B7
B4	Typical solar-electric energy conversion process	B8
B5	Typical flat-plate solar collector	B9
B6	Various cross sections of solar collectors	B10
B7	Typical photovoltaic solar cell	B11
C1	Vertical axis turbine based on work by Sheets	C9
C2	Savonius rotor based on work by Heronemus	C10
C3	Water wheel based on work by Sheets	C11
D1	Power versus windspeed characteristics of Elektro wind generators	D6
D2	Average hourly solar radiation on tilted surfaces at 40°N latitude in January	D7
D3	Average hourly solar radiation on tilted surfaces at 40°N latitude in June	D7
D4	Energy received on tilted surfaces at 40°N latitude	D8
D5	Graphical display of the equation of time	D9
D6	Latitude, longitude, and time zones of United States	D9

<u>No.</u>		<u>Page</u>
D7	Unidirectional current power production — vertical axis turbine	D10
D8	Unidirectional current power production — Savonius rotor	D11
D9	Unidirectional current power production — water wheel	D12

LIST OF TABLES

<u>No.</u>		<u>Page</u>
1	Data on Elektro G.m.b.h. Wind Generators and the Wind-driven Aeromotor Water Pumping Unit	56
2	Sample of Predicted Monthly and Annual Performance of the 5-kw Elektro Wind Generator	57
3	Summary of the Total Annual Output and the Specific Power Output of the Three Elektro Wind Generators for all the Nine Sites	58
4	Equipment and Installation Costs of Electrical Output Produced by Elektro Units	59
5	Local Source Data on Daily Averages of Solar Energy for Selected Sites	60
A1	Power Coefficient $C_p(V)$ for a 5-kw Commercial Wind Generator for Various Windspeeds	A14
A2	Frequencies of Windspeed in the Vicinity of Buffalo, New York	A15
D1	Power Coefficient C_p Shown as a Function of Windspeed V for the Elektro G.m.b.h. Wind Machines	D13
D2	Available Energy Per 100 sq ft of the Disk Area in 1 Year (8760 hours) for the Nine Selected Sites	D14
D3	Local Source Data for Hydraulic Study for Nine Sites	D15

CONVERSION FACTORS, U.S. CUSTOMARY TO METRIC (SI) UNITS OF MEASUREMENT

U.S. customary units of measurement used in this report can be converted to metric (SI) units as follows:

<u>Multiply</u>	<u>By</u>	<u>To Obtain</u>
inches	2.54	centimetres
feet	0.3048	metres
yards	0.9144	metres
miles (US Statute)	1.609344	kilometres
square inches	6.4516	square centimetres
square feet	0.09290304	square metres
acres (US Survey)	4046.856	square metres
cubic feet	0.02831685	cubic metres
cubic yards	0.7645549	cubic metres
gallons (US liquid)	3.785412	cubic decimetres
pounds (mass)	0.4535924	kilograms
tons (short)	907.1847	kilograms
horsepower	745.69999	kilograms per cubic metre
pounds (mass) per cubic foot	16.01846	kilograms per cubic metre
British thermal units (international)	1055.056	joules
langleys	41840.0	joules per square metre
pounds (force) per square inch	6894.757	pascals
knots (international)	0.5144444	metres per second
miles per hour	1.609344	kilometres per hour

<u>Multiply</u>	<u>By</u>	<u>To Obtain</u>
feet per second squared	0.3048	metres per second squared
cubic feet per minute	0.0004719474	cubic metres per second
Fahrenheit degrees	5/9	Celsius degrees or Kelvins*
BTU per pound (mass)	2326.0	joules/kilogram
BTU per pound (mass) x Fahrenheit degrees	4186.8	joules/kilogram - Kelvin
BTU per hour x feet square x Fahrenheit degrees	5.678263	watts/metre squared - Kelvin
degrees (angle)	0.01745329	radians

* To obtain Celsius (C) temperature readings from Fahrenheit (F) readings, use the following formula: $C = (5/9)(F - 32)$. To obtain Kelvin readings, use: $K = (5/9)(F - 32) + 273.15$.

IDENTIFICATION OF ALTERNATIVE POWER SOURCES FOR DREDGED
MATERIAL PROCESSING OPERATIONS

PART I: INTRODUCTION

Background

1. Dredging of sediments from the bottom of waterways is necessary to permit ship traffic. The dredged material removed is usually disposed by either placement in water outside the waterway or on land. Land disposal often involves a diked containment area where, to permit reuse of the area or the material itself, certain "passive" processing of dredged material traditionally takes place. Dredged material is usually hydraulically pumped to the containment area. The resulting slurry has a very high water content, which presents a difficult problem in draining and drying this material (particularly if the material is fine-grained clay, silt, and organic matter). Therefore, the main effort in future dredged material processing is anticipated to be drying, or dewatering, to reduce volume and stabilize the soil.

2. Historically, when there were few restraints on acquiring marginal land for disposal areas, the dredged material was left to dry rather passively by natural action of sun and wind. Minimal ditching, sluicing, pumping, and other simple assistance to nature were provided. With no great press of time or space, this passive processing continued over several years, typically between dredge fills or "lifts."

3. Now, restrictions imposed by environmental legislation on water disposal and on use of wetlands for disposal sites have caused a trend toward more disposal on land; but, at the same time, population pressures have increased land costs. This conflict has generated research to accelerate the tempo of dredged material processing - indeed, to change it to an active operation. Such active processing requires power. However, costs of energy have been increasing in recent years at very high rates, whereas alternative power system costs are relatively

constant. It is projected that electricity rates will escalate 6% to 7% annually above general inflation; alternative power system costs are projected to increase at general inflation rates.

4. The costs of petroleum products to the military have doubled in the past 2 years; for long-range planning, future increases up to 8% annually above general inflation rates are used. Electricity rates, being fuel dependent, are following similar trends. Thus, the energy costs of dredged material processing present a sizeable problem from the standpoint of fuel cost alone. Therefore, this task was formulated to provide essentially fuel-free power to the processing equipment.

Purpose

5. The objective of the study was to identify and formulate detailed descriptions of presently available or potential systems showing near-future feasibility for converting resources of energy located in the vicinity of dredging disposal sites to usable energy for operation of equipment used in dredged material processing operations. The approach taken was to acquire and organize the information necessary to do site-specific analysis of local source energy systems.

Scope

6. The scope of this study is limited to commercially available alternative power systems or those sufficiently advanced in development to be available in the near future. New untried concepts are not included.

PART II: APPROACH

General

7. The essential approach taken in this work was to acquire and organize information necessary to do site-specific analysis of local source energy systems. The methodologies expected to be analytically employed and a description of the portrayal of results are presented in this report.

8. Three tasks delineated in the Statement of Work for this study are summarized as follows:

- a. Identification and investigation of alternative energy source research and development and specification of work that may be adaptable and beneficial to the objectives of dredged material processing operations.
- b. Identification and description of potential sources of energy available at dredging and dredged material processing sites, including characterization and quantification of the energy resource and quantified descriptions of physical systems used to convert local energy sources. This task was to include investigation of potential wind, solar, and hydraulic power. Consideration was also given to the feasibility of other energy sources.
- c. Evaluation of the potential energy sources and systems by means of illustrative portrayal, data appearing in tabular or graphical form, and technical dissertation including quantitative and qualitative information. The means for detailed site-specific design and evaluation through the use of parametrically presented design, performance, and cost data are provided. Plans and procedures for the adaptation and utilization of energy at dredged material processing operations are recommended.

Study Functions

9. The following study functions were required to accomplish these tasks:

- a. Compilation of an information base, including (1) alternative energy research and development reports and results; (2) local source energy data such as winds, insolation, water currents, waste heat, and thermal gradients; (3) energy demands in dredged material processing operations and physical data describing the equipment; (4) physical data describing potential energy systems; and (5) methodologies used to analyze energy sources and systems.
- b. Construction of parametric design sizing plots for each system.
- c. Construction of parametric energy performance plots for each system.
- d. Construction of parametric cost information plots for each system.
- e. Preparation of technical dissertation on each system recommending possible plans and procedures for adaptation and utilization.
- f. Combining of all study information into a final report.

Methodologies

10. Methodologies were applied in the following areas:
 - a. Local source energy analysis; i.e., quantities of energy contained at each local source.
 - b. Energy system sizing.
 - c. Energy system performance.
 - d. Cost benefit analysis.

Data Sources

11. Wind and solar energy available in each geographical region was obtained from historical climatological data.

12. Wind-power duration curves were computed using velocity distribution data, and system energy output was computed from the envelope of windmill operation defined within the wind-power duration curve. Spatial correlations of wind energy data were computed by using a method previously derived by the principal investigator. Monthly variations in wind energy were computed from historical data.

13. Solar energy was computed using daily values of insolation for each month taken from weather station records.

14. Quantities of energy available in local water currents, waste heat, and thermal gradients were computed from available data. Energy available in water currents is simply the quantity of kinetic energy contained in a given cross section of flow. Only a certain fraction (0.30 to 0.44), depending on the efficiency of the turbine, can be converted to useful mechanical work. Energy from waste heat or thermal gradients was computed using a Rankine thermodynamic cycle operation between the head source temperature and the surroundings.

Computations

15. Mean values and variations about the mean were computed from local source data. When appropriate, probabilities of occurrence of phenomena related to energy system design, such as amounts of storage, were computed from time-dependent energy data.

16. Sizing depends on the time-dependent energy requirement, time-dependent quantities of available local energy, and efficiencies of energy conversion characteristic of each device. The available local source energy varies from site to site, and there was variation in conversion efficiencies, depending on the approach. Consequently, a parametric method of sizing was necessary.

17. A series of parametric curves were constructed showing the variation of system size with parameters such as energy source intensity, component efficiencies, demand cycle, and local source time-dependent fluctuations. Conventional sizing parameters were used, such as rated power output, collector area, pumping capacity, or storage capacity. Data necessary to size a detailed design appear on these parametric plots. System component efficiencies were taken from the survey of energy research.

18. Energy system performance is presented as a function of local energy source intensity and the time-integrated amount of local energy. For instance, windmill performance is given on two plots. One shows the

windmill system's overall power coefficient as a function of windspeed; the other shows the operational envelope of the windmill on a site-specific annual power duration plot. Area within the operational envelope gives the expected annual energy output. The site-specific power duration curve is computed from windspeed distribution data taken at or near the site. The techniques used to compute these plots are given along with typical example problems so that the method can be applied by the sponsor to any site-specific problem.

19. In the example of computing windmill performance using the power coefficient and then computing a power duration envelope, an optimum load match is assumed to occur between windmill output and load demand. In some applications, optimum load matching is a realistic assumption, but in cases where it does not occur, some technique is required to account for the loss of available energy due to load mismatching. A methodology is given in the study results that can be applied to site-specific load demand and time-dependent local energy source data to arrive at a statistically averaged load factor. Also, a similar method of analysis is given to compute required energy storage capacity, given the probabilities of minimum threshold local energy intensity occurring over specific lengths of time.

20. A similar set of methodologies is given for each type of local energy source. A sizing and performance analysis is made, using selected site data and appropriate energy systems that realistically showed promise of application at the specific sites.

Cost Benefits

21. A complete cost benefit analysis was not made on each alternative power system due to lack of data. The principal problem is that there is little or no basis for comparison inasmuch as there is no dredged material processing of any consequence taking place at present. However, at the time of application of alternative power systems, the following analysis method should be followed.

22. Each energy system should be analyzed for its cost, which should include the capital investment in machinery and its installation, the expected average annual maintenance expenses, and the cost of fuel. Where possible, real cost data should be used; but, when these data are not available, estimates should be made based on cost information obtained on similar devices. Costs of conventional machinery should be computed and used for comparison. Benefits should be computed by applying a present value cost analysis to each system, including a conventional system relying on petroleum fuel for energy. Benefits should then be reflected in a savings in life cycle cost of the local source energy system over the conventional system. The most likely benefit should be a savings in fuel expenses, but it could occur with a savings of capital investment and maintenance and operating expenses. Benefit should be also expressed as a net periodic savings in petroleum fuel. Values of interest rates and expected percentage rise in maintenance, operating, and fuel costs, as well as economic life, should be discussed with the sponsor prior to the analysis, and mutually agreeable values should be used.

23. A savings-to-investment ratio should be computed from the cost-benefit results as a relative measure of the monetary value of the system. In addition, the cost of energy expected to be delivered to the dredged material equipment by the local energy system should be computed from annual expenses and expected annual energy output. Cost data should be parametrically presented in a comprehensive manner for ready use in subsequent site-specific analyses.

Presentation

24. Results are portrayed in tabular, graphical, equation, and pictorial form, depending on the nature of information being transmitted. Data appearing in tabular form include local source energy data, such as appropriate climatological data, physical characteristics of all

existing or conceptual energy systems examined in the study, specific system performance data, specific system cost data, and operating and maintenance data.

25. Graphical results include presentations of available local source energy; time-dependent load and source power curves; parametric design curves, including the appropriate sizing information; and parametric energy performance curves. Mathematical expressions used in the analysis are presented in a comprehensive manner.

26. Pictorial illustrations, such as sketches and drawings, are provided to clarify images of the transmitted information. Sketches of proposed concepts showing their physical size and how they appear on a typical dredged material site are given. Drawings of existing equipment are presented when available.

PART III: POWER SOURCES

Wind Power

Introduction

27. The idea of developing shaft power from the wind is very old. For centuries, windmills of crude aerodynamic design have been in use in Holland, Denmark, and North Germany for grinding wheat. Such wind machines provided high torques at slow rotating speeds but were inherently inefficient because of their low tip-speed-to-wind-speed ratio. Small windmills were used to pump water on farms in the United States and in other parts of the world. The Smith-Putnam wind turbine in Vermont, which operated successfully from 1941 to 1945,¹ demonstrated the feasibility of developing large amounts of power from the wind. The two-bladed propeller of the machine was 175 ft in diameter and developed 1,250 kw in a 24-mph wind. This wind machine generated electrical power synchronously. Numerous other wind-power systems in 20- to 100-kw size have been used over the past 30 years.²⁻⁵

28. The evolution of the internal combustion engine and the growth of public electrical networks forced such windmills to disappear. Because of the diminishing supplies of fossil fuels today, however, interest in wind-power systems is renewed. Several companies market wind machines in 5- to 12-kw capacity. Currently, the National Aeronautics and Space Administration (NASA), under the sponsorship of the Energy Research and Development Agency (ERDA), is developing a 100-kw machine to generate electrical power.⁶ ERDA is also funding numerous other wind-energy-related projects at various universities and private companies.⁷

29. Commercial wind generators are available in sizes from 50 to 12,000 watts, with most designed to generate DC power only. Recently, some firms (Aerowatt of France and Elektro G.m.b.h. of Switzerland) have developed wind generators in sizes from 4- to 12-kw to produce 3-phase AC power.

30. The Aerowatt machine is designed to produce 4.1 kw at a windspeed of 16 mph with a propeller of 30.6 ft in diameter. The Elektro machines deliver 5 to 12 kw. The NASA 100-kw wind generator is still under development, and complete data on its performance are not yet available.

31. The old farm-type windmill, because of its high torque characteristics, is well suited to pumping applications. A 6-hp model of such a windmill made by Aeromotor Company is shown in Figure 1. Table 1 lists the necessary operational data on a 5-kw AC wind generator, 6- and 12-kw DC Elektro wind generators, and the 6-hp Aeromotor pumping unit.

32. A typical wind machine unit is designed to last for a period of 30 years. Therefore, when determining the economics of wind-power installations, this equipment life cycle should be used. A 12-kw DC unit installation is shown in Figure 2.

33. The system is more fully described in Appendix A.

Conversion of wind power to energy

34. Feasibility. Wind as a source of energy has many applications, will provide nonpolluting power, and will save fossil fuels for other important operations. Environmentally, the use of wind-powered systems for dredged material processing sites appears to be a promising application. For instance, utilization of wind power for operating dewatering systems may not require any storage of energy. A wind-power installation without storage (depending upon its size, the wind potential, and the remoteness of the site and the construction costs of installing the plant) can produce the power at a cost comparable to that of the existing sources of power such as a diesel engine or, in some circumstances, a public utility. A preliminary survey of the existing wind data indicates that many locations in the continental United States have attractive wind-power potential, thus making the use of wind power for dredged materials processing feasible.

35. Wind power has been used successfully in the past to pump water for drainage and irrigation of land areas in Holland. A typical drainage mill of crude design lifted water to a height of about 3 ft and

on the average pumped about 27,000 gal of water per hour during strong winds. The 19-ft-diameter, 4-bladed propeller of such a machine drained water from 37 to 50 acres of land area. Such mills converted only about 16% of the wind energy into shaft power and operated at tip speeds two to three times the windspeed. Most of the drainage mills used a centrifugal pump capable of handling large water flows under very low heads; however, due to unsteady rotational speeds the pump efficiencies were less than 40%. The inherent low efficiency of the wind-powered centrifugal pumps is due to irregular rotational speeds and low operating heads.

36. The American multibladed windmill has been used for pumping water on farms. Such a wind-power system converts about 30% of the wind's kinetic energy into shaft power; a corresponding figure for a modern propeller system is about 42%. The multibladed rotor, however, offers a good starting torque, a desirable feature for operating reciprocating pumps. The windmill system is a relatively slow turning unit with the rotor-tip-speed-to-windspeed ratio of unity. In comparison, a propeller type rotor turns at tip speed ratios of 4 to 6.

37. Costs. The Aerowatt machine costs \$19,000 and is designed to produce 4.1 kw at a windspeed of 16 mph with a propeller 30.6 ft in diameter. In comparison, the Elektro machines for 5 to 12 kw cost between \$7,000 and \$10,000. Clearly, from the initial-cost point of view the Aerowatt machine is not competitive with the Elektro units. In this study, the Aerowatt and NASA machines will not be included.

38. A 6-hp old farm-type windmill made by Aeromotor Company with a pump and the mounting tower like that shown in Figure 1 sells for about \$5,000. The equipment costs, including installation for each unit, are shown in Table 1.

Solar Radiation

Introduction

39. The sun's energy falls upon Earth continuously and gives sustenance to all life. It has been the origin of most energy sources

known to date — wood, coal, natural gas, wind, ocean, etc. The direct conversion of this solar energy output to benefit mankind is currently receiving much research and implementation. With specific attention to dredged material processing operations, solar energy conversion applications present a very formidable challenge.

40. Man has been dependent upon the sun from the beginning of time, and acknowledged its existence in many ways. However, the first most notable attempt at converting this energy was Archimedes' setting fire to an attacking Roman sailing fleet in about 212 B.C.

41. Much development work was accomplished during the Eighteenth, Nineteenth, and Twentieth Centuries on solar energy thermal conversion devices. It was not until the 1930's, however, that the photovoltaic cell proved its ability in directly converting solar energy to electricity.

42. The sun's energy can be converted by one of three processes: (a) solar-chemical, (b) solar-thermal, and (c) solar-electric. Principally, with dredged material processing operations, heat is provided to dry dredged material or electricity is provided to power electrical devices (pump motor). Each of the solar energy conversion processes is briefly discussed in Appendix B.

Conversion of solar radiation to energy

43. The effective application of any solar energy conversion process depends much on the individual components comprising the total system.

44. The solar collector is the heart of the solar energy conversion process — "it's the bucket used to catch the sun's free energy." There are several types of collectors — flat-plate, concentrator, and solar cell — each best suited for converting solar energy to benefit man.

- a. The flat-plate solar collector is primarily used for low and medium temperature (less than 200°F) fluid heating applications. It is the principal design utilized for agricultural product drying, pool water and domestic hot water heating, liquid process heating, and building space

heating and cooling. The main heat-carrying mediums used in the flat-plate collector are air and water (antifreeze, etc.).

- b. The concentrator solar collector is chiefly utilized for solar-thermal energy conversion applications necessitating high output temperatures of the heat-carrying medium (e.g., to operate turbines for electrical generation).
- c. The solar cell, or photovoltaic cell, directly converts sunlight to electrical current. Chiefly utilized in space vehicle applications in the past, it is currently receiving intensive development for terrestrial applications.

45. Appendix B discusses the basic construction materials and operating efficiencies of the various noted types of "solar collectors," as well as energy storage mediums and ancillary equipment required to make a solar energy conversion system operational.

46. Feasibility. Flat-plate and concentrator solar collectors are currently being utilized in many diversified cost-effective applications. The photovoltaic cell, however, is still much in the development stage and limited to remote-access applications where conventional power is difficult to obtain.

47. Applications. Electrical generation and drying are those applications of the sun's energy that are economically appropriate to meet the energy demands for dredged material dewatering.

48. Converting the sun's energy into electrical power is an important concern because of the dependence upon electrical devices in the United States. The solar-thermal-electric energy conversion process (solar concentrators, heat engine, and electrical generator) results in low overall efficiency and presents control and maintenance problems. The direct solar-electric process eliminates intermediate conversion equipment and requires minimum maintenance. The solar-electric process is more practical than the solar-thermal-electric process because of the limited and sparsely located electrical equipment at dredged material processing operation sites. Yet both solar energy conversion processes are still far from being cost-effective, when current or projected

availability and cost of conventional fossil fuels are considered, as well as the costs for material, labor, and maintenance of energy conversion process equipment. However, the process for future electrical generation, at selected or remote site locations, definitely points to that of direct photovoltaic conversion.

49. Solar energy naturally helps dewater dredged material spread on the ground and exposed to the sun's heat. This natural method has two distinct disadvantages: (a) an insufficient amount of sun energy may be available to evaporate water as quickly as desired; and (b) the lack of control of the surrounding atmosphere to enhance evaporation and prevent the addition of unwanted moisture (such as rainwater).

50. Costs. It is difficult to accurately predict the cost of undeveloped systems; however, some rough estimates can be made.

51. Direct production of electricity by photovoltaics today costs between \$5 and \$20 per peak watt. At such costs the payback period is too large to consider. However, the Energy Research and Development Administration (ERDA) optimistically predicts that in 10 years the cost will be reduced to \$0.50 per peak watt. Under these conditions, a cell with 1-watt peak capacity operating for 1 day could produce about 5 watt-hours of energy. A simple payback period based on commercial electricity at \$0.05 per kilowatt hour is 7 years. In other words, after 7 years, the electric power from the photovoltaic cell would be free. The life expectancy for a solar cell is 15 to 20 years.

52. Mechanical power can be produced by using solar energy as a source of heat, but such solar-powered systems are not commercially available today, although they have been used over the past three centuries. Again, it is difficult to predict the total cost of a solar-powered engine; however, a minimum cost of the solar collection required can be obtained as follows: under favorable conditions the incident solar energy is about 0.1 hp/sq ft of surface area (oriented perpendicular to the direct solar radiation). If an overall system efficiency of

10% is assumed, then 100 sq ft of collector surface area would be required to power a 1-hp engine. At present prices of \$10 to \$20 per square foot of collector area, the collector cost would be between \$1000 and \$2000.

Hydraulic Power

Introduction

53. Among the alternative power devices that may be able to provide power for the equipment at dredged material processing areas are those using hydraulic energy. For this study, hydraulic power systems include those that convert the energy in tides, ocean thermal gradients, salinity differences, waves, or currents to usable power.

Discussion of systems considered

54. Tides. In the past, tides have received more attention than any other as potential sources of hydraulic power because these sources are predictable - but they are also highly site dependent. This site dependence has limited serious consideration of large tidal power plants primarily to France, Russia, and the United States, where there are sites with very high tide ranges lying near large natural basins.⁸⁻¹⁰ No matter what size the tidal power plant is, large water storage basins are required.

55. Tidal power systems do not appear to hold promise as potential sources of power for dredged material processing. This is true because: (a) although tidal power may be cost effective on a large scale, it is probably not economical on the scale that would be required for dredged material processing; (b) the efficient use of tidal power on any scale depends to a large extent on the range of the tides at the dredge sites, and the tide ranges at the sites of interest in this study are not over 10 ft; and (c) tidewater holding basins that are required as part of tidal power systems are not generally available and could be used more efficiently as dredged material processing areas than as adjuncts to a power system for dredged material processing. Therefore, tidal power systems will not be considered further in this study.

56. Ocean thermal gradient. Presently, interest in renewable energy sources is focused on ocean thermal gradient power systems that use cold water at depth in the ocean and the warmer water near the surface in heat exchangers to produce power. The thermal gradients in the ocean are quite constant and remain so throughout the year at any location in the deep ocean. The power (from the sun) dissipated in maintaining the temperatures in the ocean is equal to about 40 billion Mw.¹¹ But at a typical location in the tropics, this vast amount of power manifests itself as only a 27°F difference in temperature between the warm water at the surface and that 650 feet below.¹² The efficiency of a heat exchanger operating with this meager temperature difference is very low (probably less than 4%).

57. Nearshore thermal gradients are not nearly as constant as those in the deep ocean, and the temperature differences are much smaller. These characteristics make thermal gradient energy conversion unsuitable for nearshore waters. Therefore, this source of power will not be considered further as a power source for dredged material processing.

58. Salinity. One potential source of hydraulic power that is present near many dredge sites is that of salinity differences. Such differences exist where freshwater meets seawater (e.g., at the mouth of a river at the ocean or in an embayment). It was theoretically estimated by Norman¹³ that a United States total of almost 120,000 Mw of salinity power exists from runoff into the oceans and the Gulf of Mexico. The fact that this type of energy exists is evidenced by the osmotic pressure that builds up at a semipermeable membrane separating fresh and saline water and drives the freshwater to the other side.

59. Some laboratory models of devices to tap energy from salinity differences have been devised,^{8-10,14} but this energy source has not as yet been adequately researched.¹⁵ The development of an operational salinity power system is not expected in the foreseeable future, so this source of power for dredged material processing will not be considered further in this report.

60. Waves. The most clearly evident source of hydraulic energy is that of the waves that come to shore and expend their energy in breaking. Many devices have been conceived for conversion of wave energy to usable power. Available wave energy depends on the wave height (the vertical distance between the trough and crest of the wave) and period (the time between successive waves). High waves of long period have more energy than low waves of short period. Ocean waves vary widely, and the characteristics of these waves differ with location, season, and year.

61. Four types of wave power systems have been conceived: (a) wave-induced surge, (b) orbital water particle motion, (c) vertical motion of the water surface, and (d) pressure changes under water. However, none of these wave power systems are much beyond the conceptual stage for land-based applications.

62. The combination of the wave characteristics at dredged material processing sites may make energy from waves a viable alternative and one of the wave power systems above may make this extraction possible. Therefore, the equipment and analysis methodologies for wave power systems are described in Appendix C.

63. Current. Another potential source of hydraulic power is water current. These currents include the major ocean currents, the currents in inland watercourses, the flow of dredged material in dredging operations, and the tidal currents in coastal waters.

64. The feasibility of extracting sizeable amounts of power from the Florida Current portion of the Gulf Stream System, the most rapid ocean current near the U.S. coast, was investigated in 1974. It was found that, although the kinetic energy in the Florida Current off Miami has the potential of producing 25,000 Mw, it might not be possible to extract more than 4% of this power.¹⁶ The highest speed portion of the Florida Current is several miles offshore* and limits the application of this potential source of hydraulic power for small shore-based activities, such as confined dredged material processing.

* True of most major ocean currents.

65. Inland watercourse currents, on the other hand, may exist beside, or very near, dredging sites. The direct use of these currents without damming a stream or requiring a significant difference in elevation along the stream is possible with turbines installed directly in the flow of the watercourse or with waterwheels. Power turbines are presently under development but are not yet available off the shelf. Waterwheels, used for centuries, are very inefficient compared to turbines.

66. Currents in inland watercourses which may be dammed and have significant elevation differences along the stream can also be used to generate power. Small dams are used to store and elevate the water and discharge it through pipes to small hydraulic turbines that are available off the shelf. These turbines require an elevation head of at least 6 ft and produce power up to 10 kw.

67. Connecting such a turbine to the pipe carrying the discharge from hydraulic dredging operations could be another source of hydraulic power. The feasibility of using a solids-laden effluent to drive a freshwater turbine has not been demonstrated.

68. Tidal currents in coastal waters (like inlets to bays or upstream of river mouths) change direction and distribution with time. This difference in flow characteristics from those of inland watercourses, which normally have unidirectional flow, requires adjustments to the power plant design to give effective energy recovery.¹⁷ Such adjustments are possible.

69. Major ocean currents as a power source for dredged material processing are not feasible.

70. Direct use of unidirectional currents in inland watercourses and tidal currents in coastal waters without dams may have application to dredged material processing operations. Such current power systems and the analysis methodologies for these are described in Appendix C.

71. Use of small off-the-shelf turbines for power generation from currents in inland watercourses with significant elevation differences along the watercourse and which may be dammed may be possible but is

site dependent. Adequate information is readily available on these turbines from manufacturers, like James Leffel Company in Springfield, Ohio; this equipment will not be discussed further in this report.

72. Feasibility of using these small turbines to extract power from the discharged material from dredging operations is questionable. Conversion of hydraulic power to energy

73. Feasibility. Waves and currents are more reasonable alternative power sources for dredged material processing operations than other hydraulic sources. Tides, ocean thermal gradients, and salinity differences are considered much less feasible alternatives at present. Consequently, only wave and current power systems are addressed further.

74. Applications. Presently, wave or current power systems are not used extensively, and equipment is not available off the shelf except for small hydraulic turbines which generate small amounts of power (under 10 kw) from currents in dammed streams. These systems are usually found in rural areas, and the power they produce is used for domestic applications.

75. Costs. Cost information for hydraulic power systems of the wave and current types is minimal since these systems are primarily still in the early stages of development.

76. *Wave power systems* cannot compete with existing power systems at today's fuel prices.¹⁸ Based on the rough calculations these authors made without even including costs of moorings, accumulators, power generators, and turbines, a wave power system would cost \$750/kw of installed capacity. These calculations were made for waves of 5-ft height and 4-second period.¹⁸

77. *Current power systems* that require no head are under development, and an estimate of their cost was made by Somers and Shoupp.¹⁹ These authors, basing their estimates on immersed Kaplan turbogenerator units operating in the Florida current, calculated minimum costs of \$100/kw for 50,000-kw units and about \$200/kw for 5,000-kw units.¹⁹ Scaling laws would probably raise the cost of a 500-kw unit of this type to over \$300/kw.

78. Current power systems for watercourses with elevation differences along a river which may be dammed are available off the shelf. The costs of these systems are a function of the available head and quantity of flow in the watercourse. Typical costs for a head of 10 feet and flows as given are:

<u>Power (kw)</u>	<u>Flow (ft³/min)</u>	<u>Cost per kw (\$)</u>
1	155	6300
3	370	2400
5	590	1550

Do-it-yourself units of this type can be made for elevation heads as low as 1.5 ft if reservoir land is available to contain the water. Such units are likely to be less efficient and more costly per kilowatt than manufactured units.²⁰

PART IV: REGIONAL ASSESSMENT OF POWER SOURCES

Wind Power

Potential for nine sites

79. The wind-power potential of a given site is determined by use of the power duration curves in Figures 3 through 11 to compute the output of a wind machine of known performance data. For demonstration of the detailed computations, the output of the 5-kw AC Elektro unit was computed for the Buffalo site and is given in Table 2. Thus, by use of the wind data for each site and Equation A4, the output of the 5-kw unit was computed on a monthly and annual basis for all nine sites. The tabulation of results includes the available energy in the wind, the wind machine output, and its specific power output (SPO) by the month and year for the site. The results also include the average power coefficient for the machine at the site. A mean monthly value was recorded with the months of the year in which excess or deficiency of energy occurs. For completeness, the details of the predicted monthly and annual data on the performance of the 5-kw unit for the remaining eight sites are listed in Appendix D.

80. For comparison, the total annual outputs of the other Elektro wind generators (the 6- and 12-kw DC power plants) were also computed for all nine sites and are shown in Table 3. There is a very small difference between the outputs of the 6-kw DC and the 5-kw AC units. The energy output of the 12-kw unit, however, is generally about 75% higher than the other two. The specific power output of the 5-kw AC unit is invariably higher than that of the 6-kw DC unit, which, in turn, is higher than that of the 12-kw DC unit. The data show that the 5-kw AC unit delivers its full rated output for a longer period than the other two units, thus showing a better match between unit and site.

Cost information

81. The economics of wind power were determined for each site by dividing the equipment and installation costs of each power plant by its total output for a period of 30 years. Table 4 shows distribution of initial costs of the plants on a kilowatt-hour basis for the machine. It should be noted that at present the wind generators available commercially are not mass-produced and, thus, the cost of fabricating each unit is considerably higher than if it were mass-produced. Hence, to make a reasonable estimate of the initial costs per kilowatt-hour output of a wind-power installation, the interest on the initial capital required for the installation is not taken into account. In other words, it is assumed that the total cost, including the interest on the capital of a mass-produced unit, will be equal to the present selling price of the unit. It is clear from the data given in Table 4 that the equipment and other initial costs of delivering energy by the 5- or 6-kw units at Buffalo is about \$0.0320/kw-hr, whereas, for the same units installed in the vicinity of Savannah, it is about \$0.0845/kw-hr. Costs for the 12-kw unit, however, at these locations are \$0.0243 and \$0.0657/kw-hr, respectively. The ascending order of initial costs per kilowatt-hour of energy for the various sites is Buffalo, Galveston, Seattle, Norfolk, Detroit, Mobile, Philadelphia, Portland, and Savannah. It can be seen from the data that the distribution of initial costs for each kilowatt-hour for the 12-kw wind generator is generally about 22% lower than for the 5- or 6-kw machines. The costs for the 5-kw AC and 6-kw DC units are very close at all locations except at Portland, where the 5-kw machine is about 11% higher than the 6-kw unit.

Solar Radiation

82. The amount of sun energy available at the earth's surface is chiefly dependent upon: (1) geographical location, (2) altitude, (3) climatic conditions, (4) time of day and year, and (5) inclination and

orientation of the solar energy receiving surface. Recorded solar energy data, received on horizontal surfaces at selected site locations, are displayed in Table 5 and in Figure 12 for comparison only. If the collector surface is tilted facing south, the inclination angle greatly affects the amount of solar energy it receives throughout the year. This relationship is detailed in Appendix D, as well as other particulars pertinent to determining the availability of the amount of solar energy under given conditions.

Hydraulic Power

Potential for nine regions

83. Wave power. The characteristics of ocean waves (height and period) vary widely on the coasts of the United States. Most of the waves off the West coast of the United States range in height from 3 to 10 ft with periods from 5 to 11 sec; on the East coast, 1 to 8 ft, 5 to 9 sec; and on the Gulf coast, 1 to 5 ft, 1 to 5 sec (abstracted from data compiled in Reference 21). On both the East and West coasts higher waves of longer periods are found in the winter, but on the Gulf coast the wave heights and periods do not vary much except during hurricanes. The West coast appears more promising from the standpoint of the amount of wave power available; the East coast, less so; and the Gulf coast, least. However, Gulf coast waves would provide a more constant source of power, and their regularity may be an overriding consideration. Therefore, the wave characteristics at dredged material processing sites on any U.S. coast may be such that waves represent a viable energy source.

84. However, waves are found at only two of the nine sites considered: Galveston with waves averaging between 1 and 5 ft and Toledo with waves averaging 1 ft with occasional maximums of 8 ft. These waves are not consistently high enough to warrant further consideration of wave power as an energy option.

85. Current power. Theoretically, any unidirectional current may be used for the direct (i.e., without damming the watercourse) generation of power, but the economics of generating power (the capital cost of the equipment versus the cost benefits of the power produced) from weak currents make this generation infeasible. Only one of the nine sites has a purely unidirectional current: Cayuga Island in the Buffalo District where the average current is only 1.5 knots. Power generation at this site with this current would require a very large turbine with a volume of over 30,000 ft³.

86. Although tidal currents, as well as unidirectional currents, can be used to directly generate power, a lower limit (2.1 knots) to the tidal current speed required to generate power exists. This limit is available in one direction (ebb or flood) at five of the nine sites considered, but at only one site (Portland District-Clatsop Spit) in both directions.

Relative regional costs

87. Four types of wave power systems have been conceived, but none of these has gone much beyond the conceptual stage of development for land-based applications. Preliminary estimates of the cost of wave power systems indicate that these systems cannot compete with existing power systems at today's fuel prices. Use of waves as an alternative source of power for dredged material processing is not feasible for the nine sites considered here.

88. Current power systems for use in either unidirectional or tidal currents for watercourses that may not be dammed were considered. It was found that for unidirectional currents the vertical axis turbine was preferred; and for tidal currents, the Savonius rotor. Equipment components for these have been developed, but total systems for power production have not yet been assembled and tested. The power available from these is a function of the area of the system projected in the direction of current flow and the cube of the current speed. For example, a typical vertical axis turbine 60 ft in diameter with an overall efficiency of 44% operating in a 2-knot unidirectional current would produce 50 kw.

89. Current power systems can be obtained off the shelf for dammed watercourses with an elevation head of at least 6 ft. The power generated with these off-the-shelf systems depends on the head and the flow in the watercourse but is limited to 5 kw when the elevation head is less than 10 ft.

90. The cost of current power systems for use in watercourses that may not be dammed is estimated at \$300/kw, assuming that a 500-kw system is used (this is the smallest current power system of this type that has been considered). The cost of a typical current power system (hydraulic turbine) for use in a dammed watercourse with a head of 10 ft is \$1,550/kw for a 5-kw system.

PART V: CONCLUSIONS AND RECOMMENDATIONS

Conclusions

General

91. Wind machine. Wind machines are commercially available now to provide electrical or mechanical power. Wind-generated electricity is shown to be comparable in cost to purchased electricity at certain dredging sites. However, even though wind power concepts are cost beneficial, they might prove to be technically unattractive because of the relatively low outputs available from a single machine. Matching of wind-derived energy to processing systems requires additional effort.

92. Solar radiation. Commercial thermal solar collectors are not well adapted to proposed processing systems. Solar cell electrical devices are not cost competitive with conventional electricity sources at present.

93. Hydraulic power. Hydraulic power extraction from river currents, though possibly applicable, is not readily available. Wave power is limited in application and not commercially available at this time. Mini-hydroelectric plants on nearby streams may be applicable at certain sites.

Wind power

94. The following conclusions were reached:

- a. Utilization of wind power to operate the dewatering systems at dredged material processing sites seems to be very promising at Buffalo and Galveston - each with an annual available energy density of 166 and 147 kw-hr/sq ft of the disk area, respectively. The sites in the vicinity of Norfolk, Detroit, Mobile, Philadelphia, and Seattle show marginal potential with yearly available energy density varying from 84.8 to 115 kw-hr/sq ft of the disk area. Finally, the sites near Savannah and Portland, each with an energy density of 57 and 67.6 kw-hr/sq ft/annum, show relatively poor promise.
- b. Many practical constraints exist, however, which can influence the application of wind power at dredged material sites, such as the necessity for special foundation designs and availability of suitable pumping equipment. Additional

research is required to determine the various constraints and their effect on the utilization of wind power at these sites.

- c. Commercial wind machines with or without a generator with 5- to 12-kw size are on the market and can deliver either AC or DC power or drive a water pump. In particular, 6-kw DC, 5-kw 3-phase AC, and 12-kw DC units are readily available from Elektro company in Switzerland while a 6-hp wind-powered pumping unit is marketed by Aeromotor Company in the United States. These systems, with some modifications, can be adapted to the dewatering operations.
- d. With commercial wind generators the cost (excluding the interest on the capital) of energy per kilowatt-hour delivered at Buffalo by the 6-kw DC, 5-kw AC, and 12-kw DC units is estimated at \$0.0317, \$0.0323, and \$0.0243, respectively. The cost per kilowatt-hour for the same three units at Savannah is \$0.0847, \$0.0843, and \$0.0657, respectively. The cost of wind-generated power at the remainder of seven sites varies between that of Buffalo and Savannah (Table 4).
- e. A procedure for computing wind energy potential using existing long-term data for a site is presented, and it is shown that the windspeed and the corresponding power duration curves are powerful tools in estimating the wind-power potential of a site. It is suggested that special attention be given to the time of year in wind-power analysis because there are substantial variations in wind velocities from month to month. Next, the concept of the specific power output, a commonly used parameter for evaluating the performance of a given wind machine installation, is introduced.
- f. A correlation scheme, based on the statistical theory of turbulence, enables a wind energy prospector to readily and economically estimate the wind-power potential of a site without long-term wind data simply by making short-term measurements on the site and correlating them with the long-term data from the neighboring weather stations. The correlation scheme yields good results in cases where wind data follow the normal distribution. However, more work is required to extend the method to incorporate the effects of thermally induced turbulence and local terrain roughness. This will be published separately.
- g. The method of mechanically mixing the wind generator output with the existing utility grid to operate a water pump at constant speed improves its efficiency and delivers continuous stable power.

Solar radiation

95. Dredged material processing operations present a formidable challenge for solar energy conversion applications. Basic considerations are as follows:

- a. Water elimination from dredged material is of chief concern.
- b. Working environment, usually close to coastal waters, usually indicates an overcast sky and water-salt-corrosion/wind-spray conditions.
- c. Ground surface may be both muddy and dirty, as well as unsettled.
- d. Electrical power requirements are high for driving pumps, which would necessitate large solar collector receiving surface areas.
- e. Available space for solar collector array structures is limited.
- f. Locations of operations tend not to be fixed in a static position.

Hydraulic power

96. In the evaluation of hydraulic power sources as alternatives to conventional power for dredged material processing operations, currents or waves were found to be better alternative sources of power than tides, ocean thermal gradients, or salinity differences.

97. Current power systems for watercourses that may not be dammed have not been developed. However, current power systems for watercourses that may be dammed are available off the shelf and may be used where there is adequate reservoir space. Machines deriving their motive power from the end of pipelines have not been developed.

Recommendations

General

98. It is recommended that a wind generator be installed at Buffalo or Galveston matched to a suitable dredged material processing system to demonstrate the utility of alternative power systems.

Wind power

99. Although wind generators with 5- to 12-kw capacity are

commercially available, the methods and hardware to utilize their variable outputs to match the characteristics of dewatering equipment at dredging sites have to be developed for efficient utilization of wind power. Further work, therefore, is recommended, as follows:

- a. Investigate impact of factors involved in practical utilization of wind power.
- b. Explore further the use of an automatic load switching device for matching loads to the generator's output and its use as a power mixing device.

Solar radiation

100. With regard to the findings and special emphasis on simplicity, reliability, and cost-effectiveness, the following recommendations are presented.

- a. Attempts at electrical generation, via either the solar-thermal-electric or direct photovoltaic conversion, should be considered "experimental" - with all associated risks because of: (1) the low energy-conversion efficiency of the system, (2) the expensive capital equipment, and (3) the system hardware maintenance/control upkeep.
- b. Thermal storage of solar energy should not be considered because of: (1) space limitations, (2) weight capacity consideration, and (3) movement of operations.

Hydraulic power

101. Current power systems for dammed watercourses are recommended where elevation head of over 6 ft along the watercourse can be obtained and where the power required is less than 5 kw.

102. The following are not recommended:

- a. Tidal, ocean thermal gradient, and salinity hydraulic power systems, because they are not feasible for dredged material processing operations.
- b. Wave power systems, because land-bound applications are still under development and none of the nine sites have suitable wave conditions.
- c. Current power systems for undammed watercourses, because these are still under development.

REFERENCES

1. Putnam, P. D., Power From the Wind, Van Nostrand, New York, 1948.
2. Hutter, U., "Past Developments of Large Wind Generators in Europe," Proceedings Wind Energy Conversion Systems Workshop, National Science Foundation, NSF/RA/W-73-006, 1973, pp 19-22.
3. Hutter, U., "The Development of Wind-Power Installations for Electrical Power Generation in Germany," Technical Translation NASA TTF-15050, Aug 1973, National Aeronautics and Space Administration, Washington, DC.
4. Sectorov, V. R., "The Balaklavsking Experimental Electric Wind Station," Elektrichestro, No. 19, 1933.
5. Golding, E. W., "Electrical Energy from the Wind," Proceedings, Institution of Electrical Engineers, Vol 102, No. 6, Pt. A, 1955, pp 677-687.
6. Puthoff, R. L., "Status of 100 KW Experimental Wind Turbine Generator Project," Proceedings of Second Workshop on Wind Energy Conversion System, 1975, pp 21-36.
7. DiVone, L., "Overview of WECS Program," Proceedings of the Second Workshop on Wind Energy Conversion Systems, 1975, pp 5-11.
8. Charlier, R. H., "Harnessing and Energies of the Ocean, Part I," Marine Technology Society Journal, Vol 3, No. 3, May 1969, pp 13-32.
9. Charlier, R. H., "Harnessing and Energies of the Ocean, Part II," Marine Technology Society Journal, Vol 3, No. 4, Jul 1969, pp 59-81.
10. Charlier, R. H., "Harnessing and Energies of the Ocean, Postscript," Marine Technology Society Journal, Vol 4, No. 2, Mar-Apr 1970, pp 63-65.
11. Isaacs, J. D. and Seymour, R. J., "The Ocean as a Power Source," International Journal of Environmental Studies, Vol 4, 1973, pp 201-205.
12. Lavi, A., and Zener, C., "Solar Sea Power Plants - Electric Power From the Ocean Thermal Difference," Naval Engineers Journal, Vol 87, No. 2, Apr 1975, pp 33-46.
13. Norman, R. S., "Water Salination: A Source of Energy," Science, Vol 186, No. 4161, 25 Oct 1974, pp 350-352.
14. Strong, C. L., "Machines That Work Like Muscles," Scientific American, Apr 1973, pp 112-117.
15. McWethy, P. J., "Process for Determining the Federal Role in Stimulating Development of Ocean Energy Technologies," Proceedings of Tenth Annual Conference, Marine Technology Society, Washington, DC, Sep 1974, pp 465-481.
16. Stewart, H. B., "Ocean Energy Possibilities," Proceedings, MacArthur Workshop on the Feasibility of Extracting Usable Energy From the Florida Current, 1974.

17. Sheets, H. E., "Power Generation From Ocean Currents," Naval Engineers Journal, Vol 87, No. 2, Apr 1975, pp 47-56.
18. Wechsler, L., Brown, C. E., and Sundarama, T. R., "Engineering Analysis of Systems for Extracting Useful Energy from the Sea," Tenth Annual Conference, Marine Technology Society, 1974, pp 482-499.
19. Somers, E. V. and Shoupp, W. E., "Electric Power Production From the Florida Current," Proceedings, MacArthur Workshop on the Feasibility of Extracting Usable Energy From the Florida Current, 1974.
20. Hamm, H. W., "Low-Cost Development of Small Water Power Sites," Apr 1975, Volunteers in Technical Assistance, Inc., Mt. Rainier, MD.
21. Hogben, N., and Lumb, F. E., Ocean Wave Statistics, Hillman, London, 1967.
22. Walton-Smith, F. G., "Power From Sea Motion," The Seas in Motion, Thomas Y. Crowell, New York, 1973, pp 227-234.
23. Heronemus, W. E., et al., "On the Extraction of Kinetic Energy from Oceanic and Tidal River Currents," Proceedings, MacArthur Workshop on the Feasibility of Extracting Usable Energy From the Florida Current, 1974.
24. U.S. Patent Office, Patent Search, "Utilizing Ocean Waves as a Power Source," 3 Dec 1974.
25. Salter, S. H., "Wave Power," Nature, Vol 249, Jun 1975, pp 720-724.
26. Canney, H., "Supplemented Tidal Electrolytic Energy Report," Proceedings of Tenth Annual Conference, Marine Technology Society, Sep 1974, pp 509-516.
27. Schuessler, R., "Energy From Sea, Tides, and Waves," Seaports and Shipping World, Jul 1974, pp 24-25 and 46.
28. Silvers, J. P., "Successful Conversion of Ocean Wave Energy," Proceedings, Buoy Technology Conference, Marine Technology Society, 1964, pp 173-198.
29. "New Concept for Extracting Power From the Sea," Ocean Industry, Vol 10, No. 2, Feb 1975, pp 168-170.
30. Pepper, P. A., "The Use of Propeller-Type Turbines for Extraction of Ocean Energy," Proceedings, MacArthur Workshop on the Feasibility of Extracting Usable Energy From the Florida Current, 1974, pp 104-113.
31. Liu, B. H., and Jordan, R. C., "A Rational Procedure for Predicting the Long-Term Average Performance of Flat-Plate Solar Energy Collectors," Solar Energy, Vol 7, 1963, pp 53-56.
32. Vodraska, K., "Determining the Availability of Solar Energy Within the Contiguous United States," 1975, EI&I Associates, P.O. Box 263, Newbury Park, California 91320 (\$4.00).

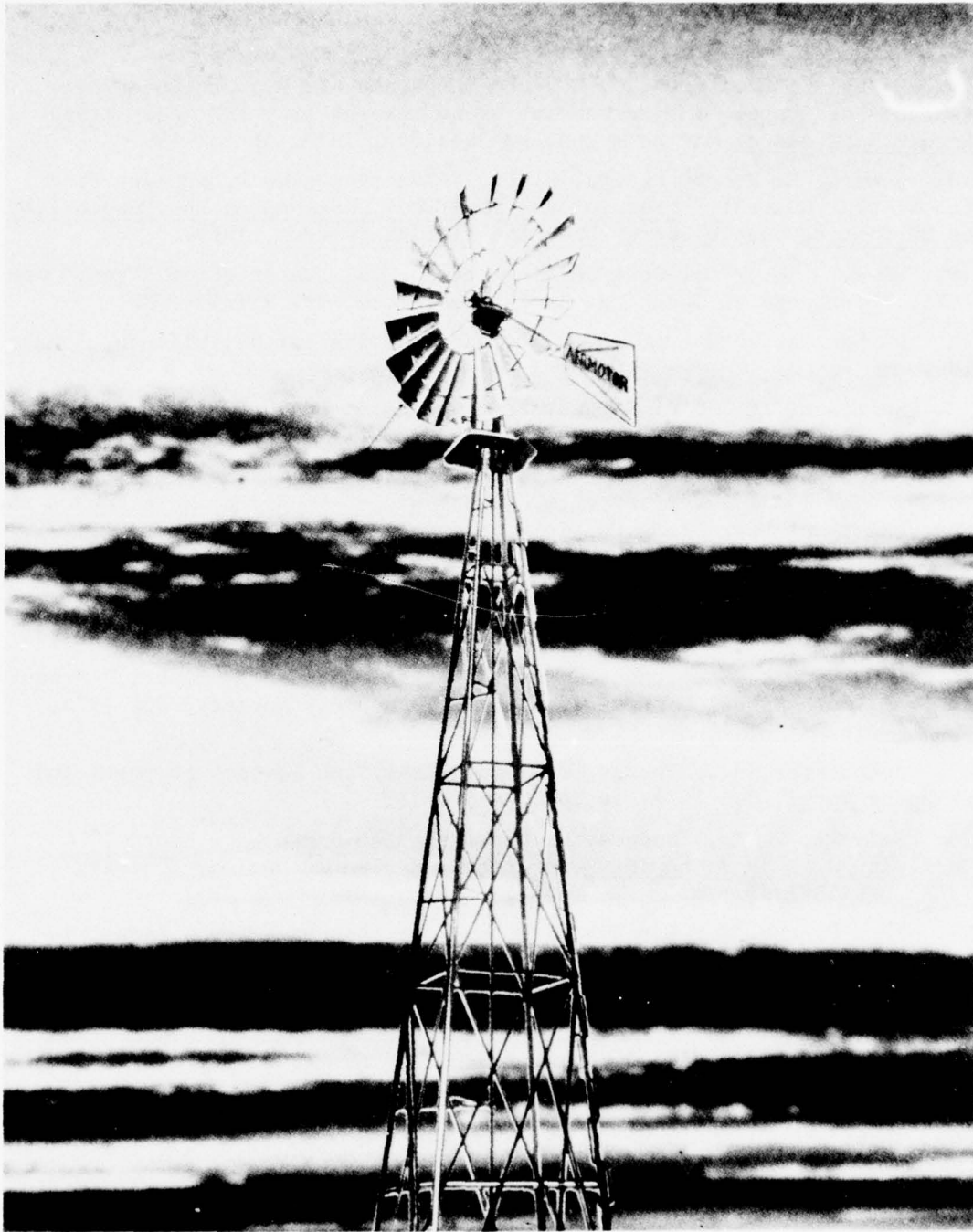

Figure 1. Aeromotor 6-hp, wind-driven water-pumping unit with a rotor diameter of 16 feet

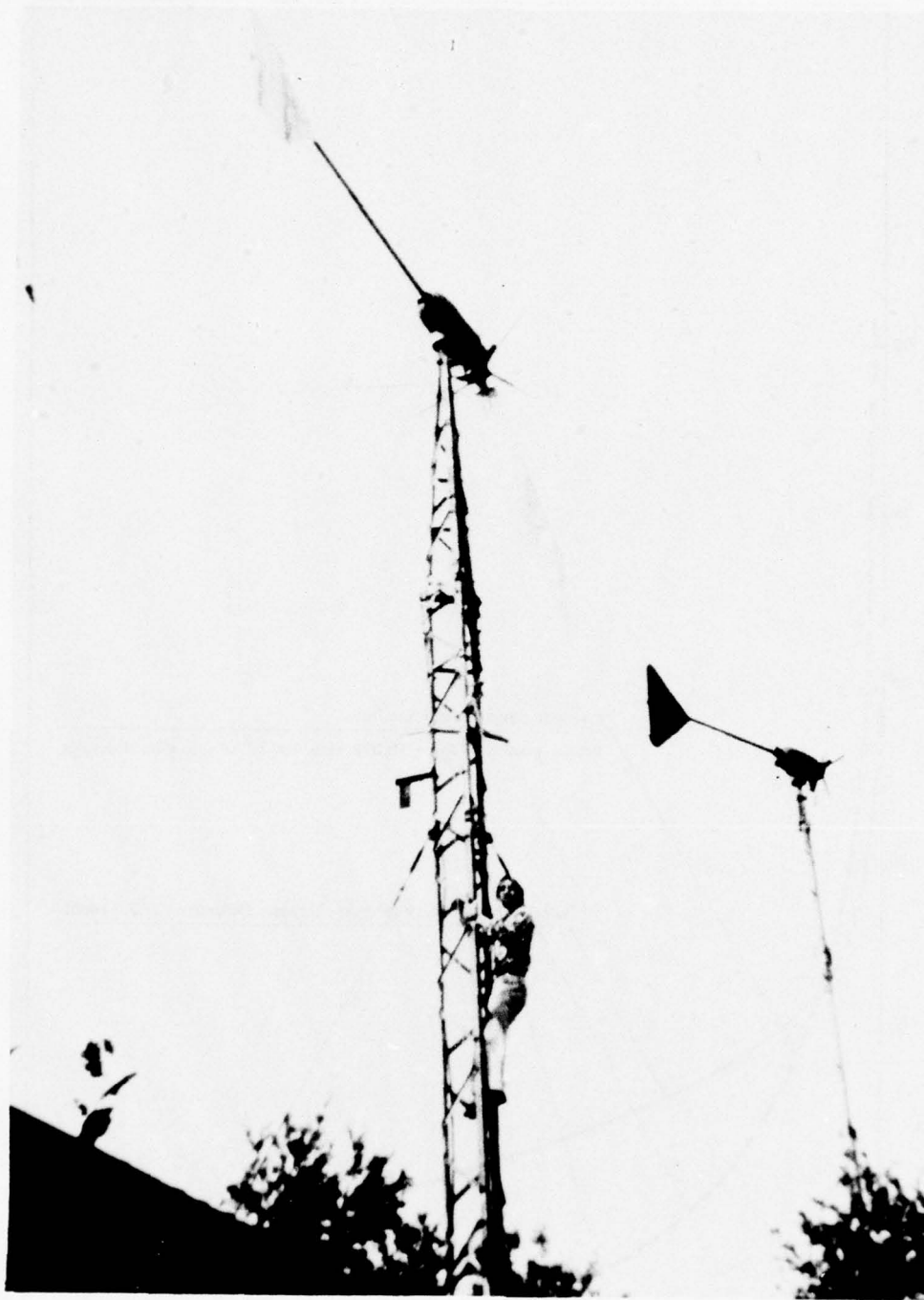

Figure 2. Elektro 12-kw DC wind generator installation near Wintertzur, Switzerland. The wind machine has a propeller 21 feet 6 inches in diameter

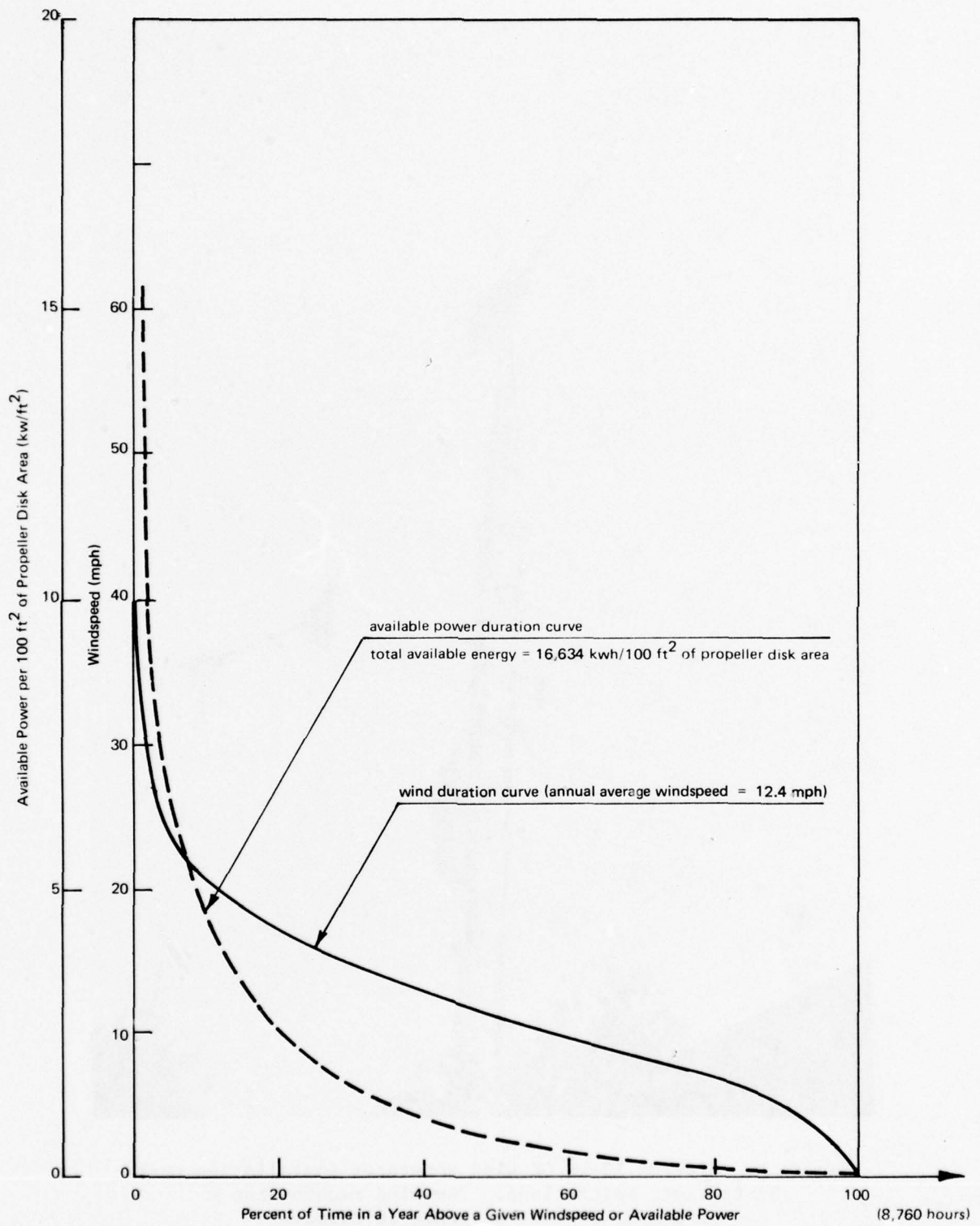

Figure 3. Windspeed and power duration curves for a site near Buffalo

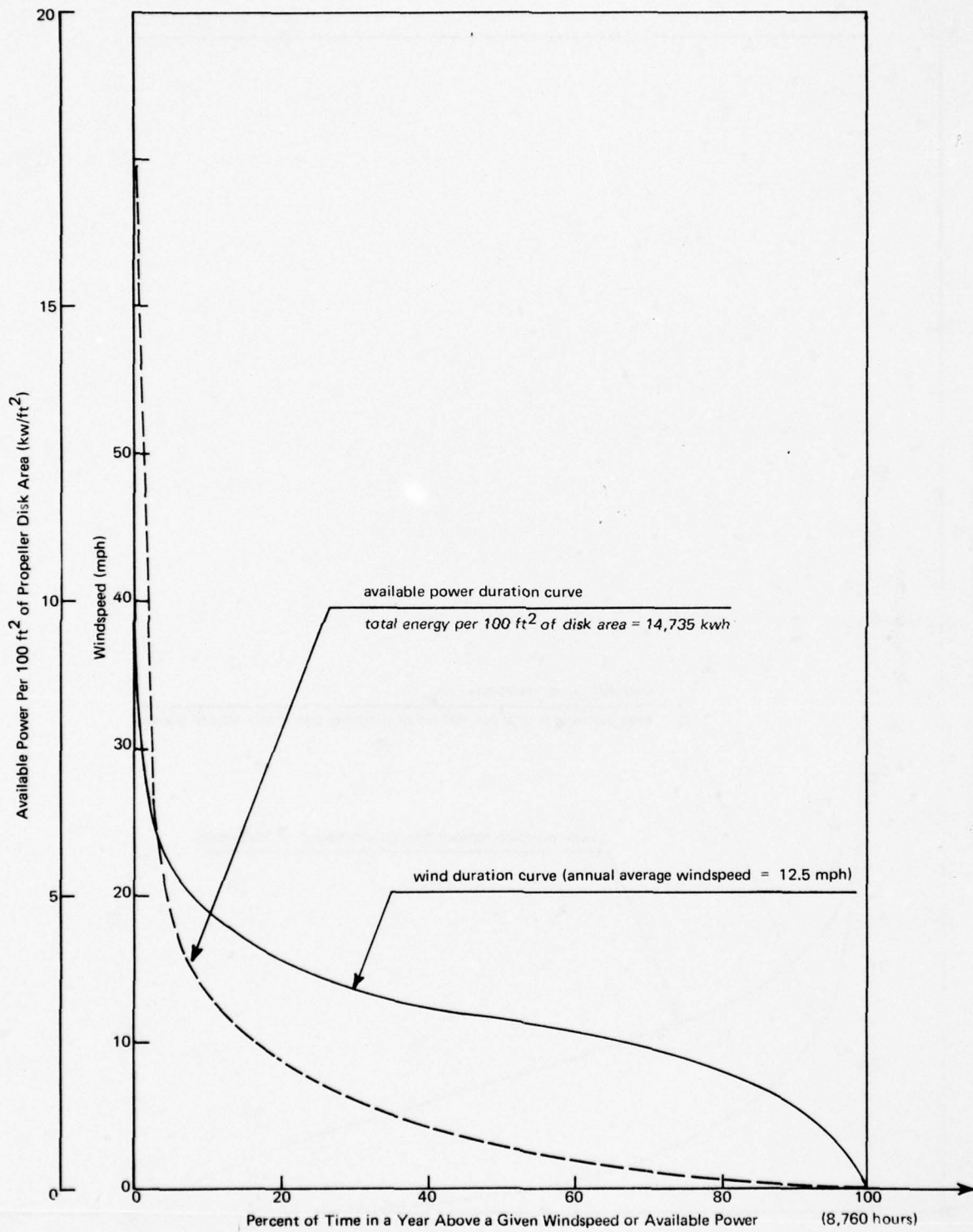

Figure 4. Windspeed and power duration curves for a site near Galveston

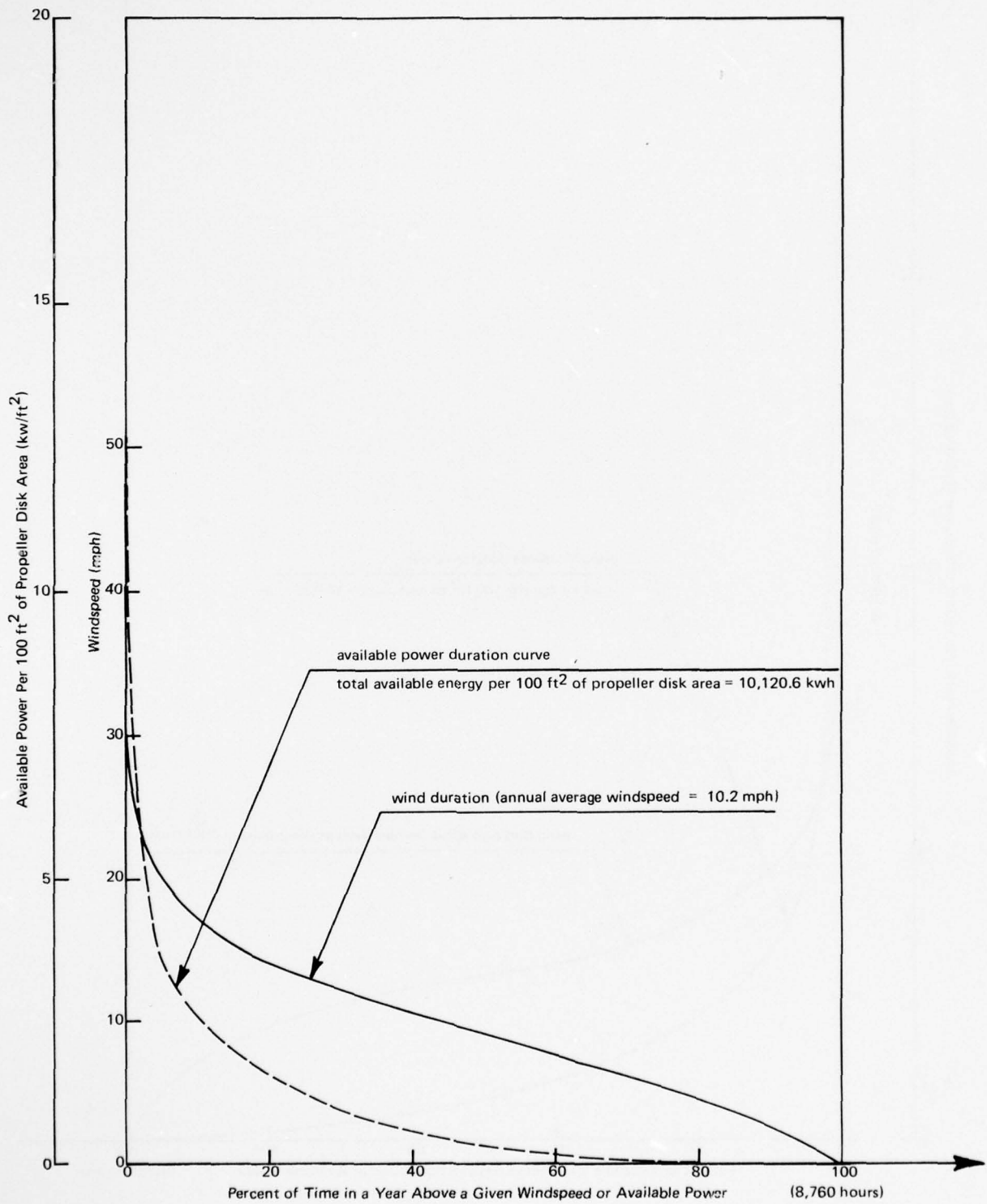

Figure 5. Windspeed and power duration curves for a site near Norfolk

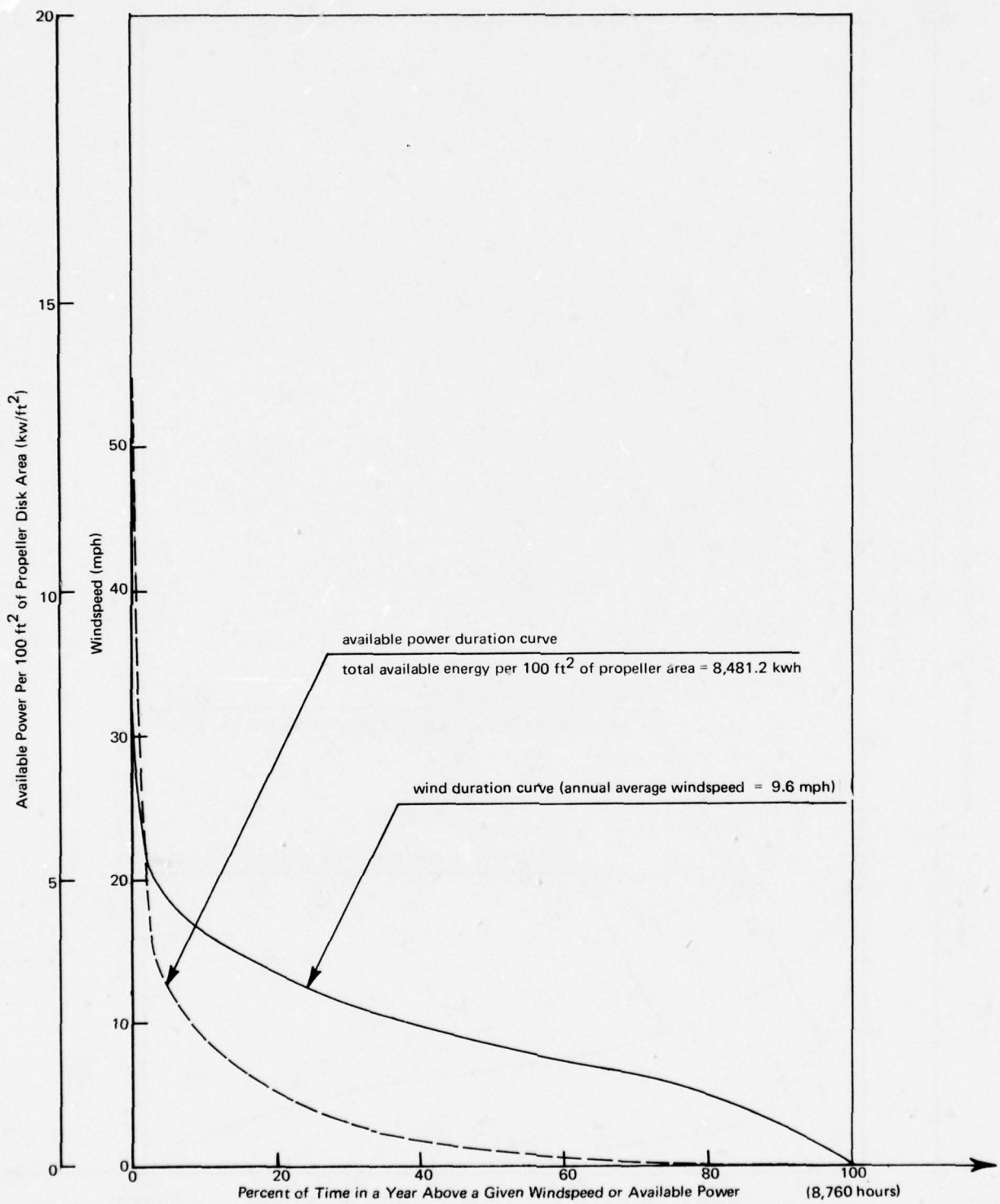

Figure 6. Windspeed and power duration curves for a site near Philadelphia

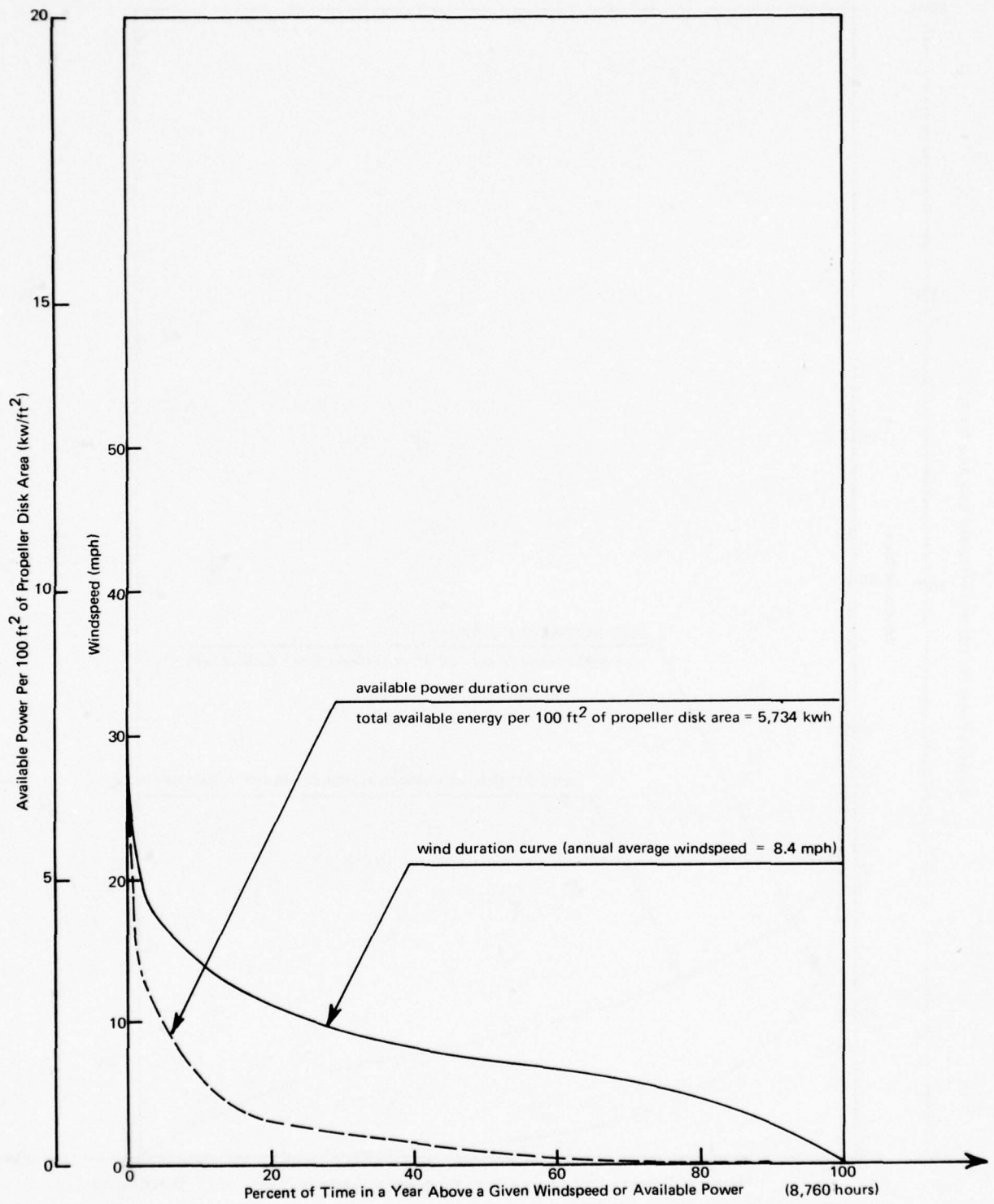

Figure 7. Windspeed and power duration curves for a site near Savannah

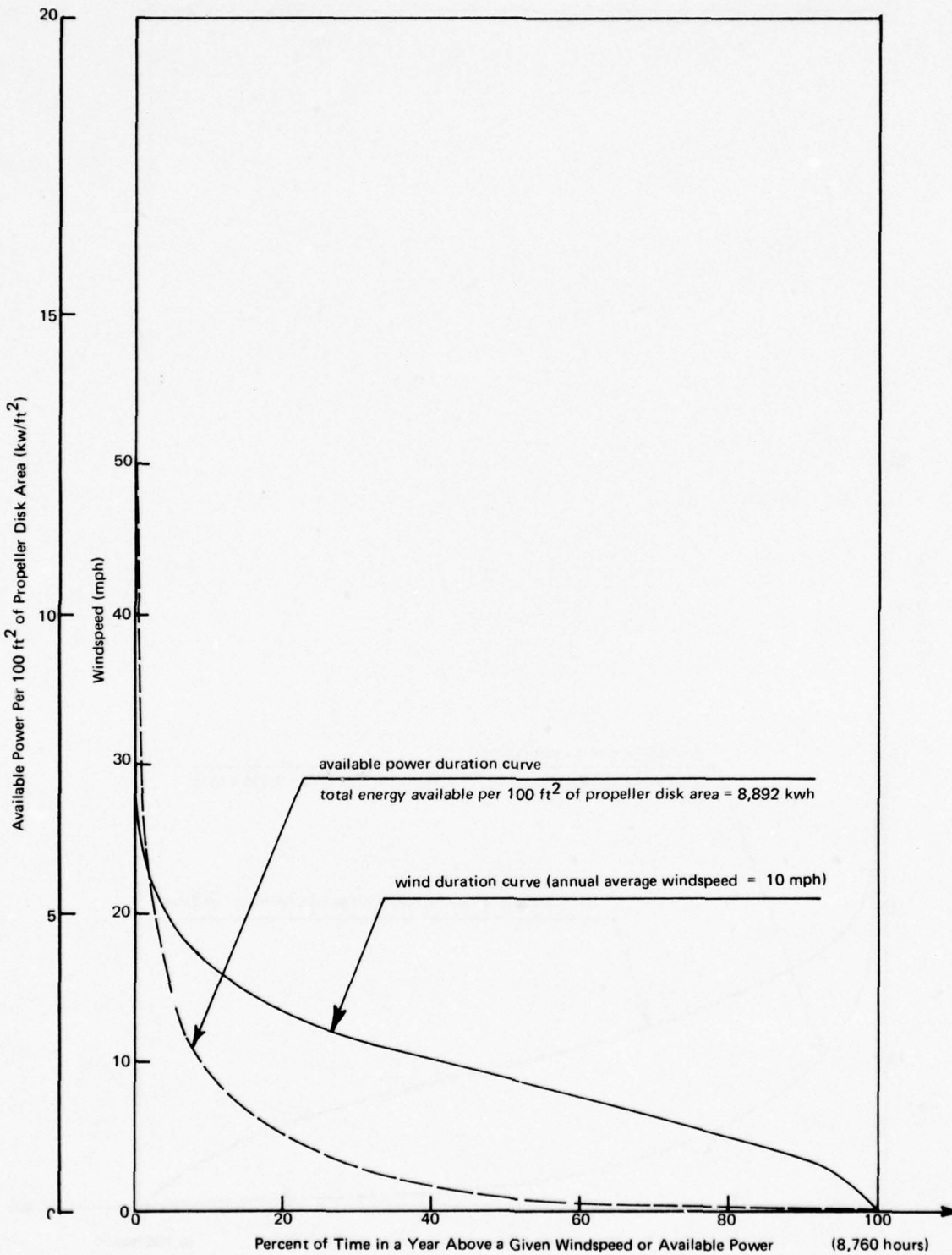

Figure 8. Windspeed and power duration curves for a site near Mobile

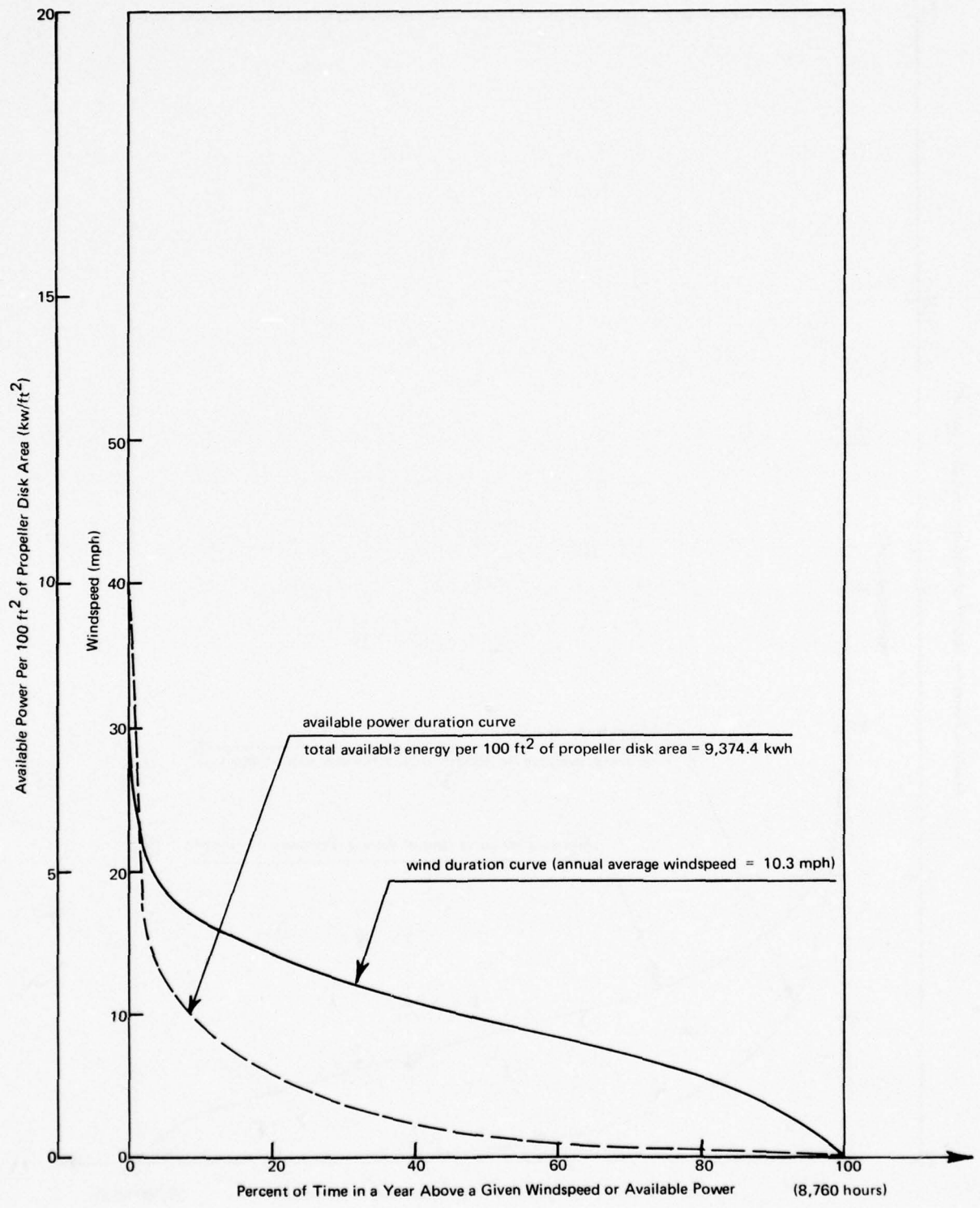

Figure 9. Windspeed and power duration curves for a site near Detroit

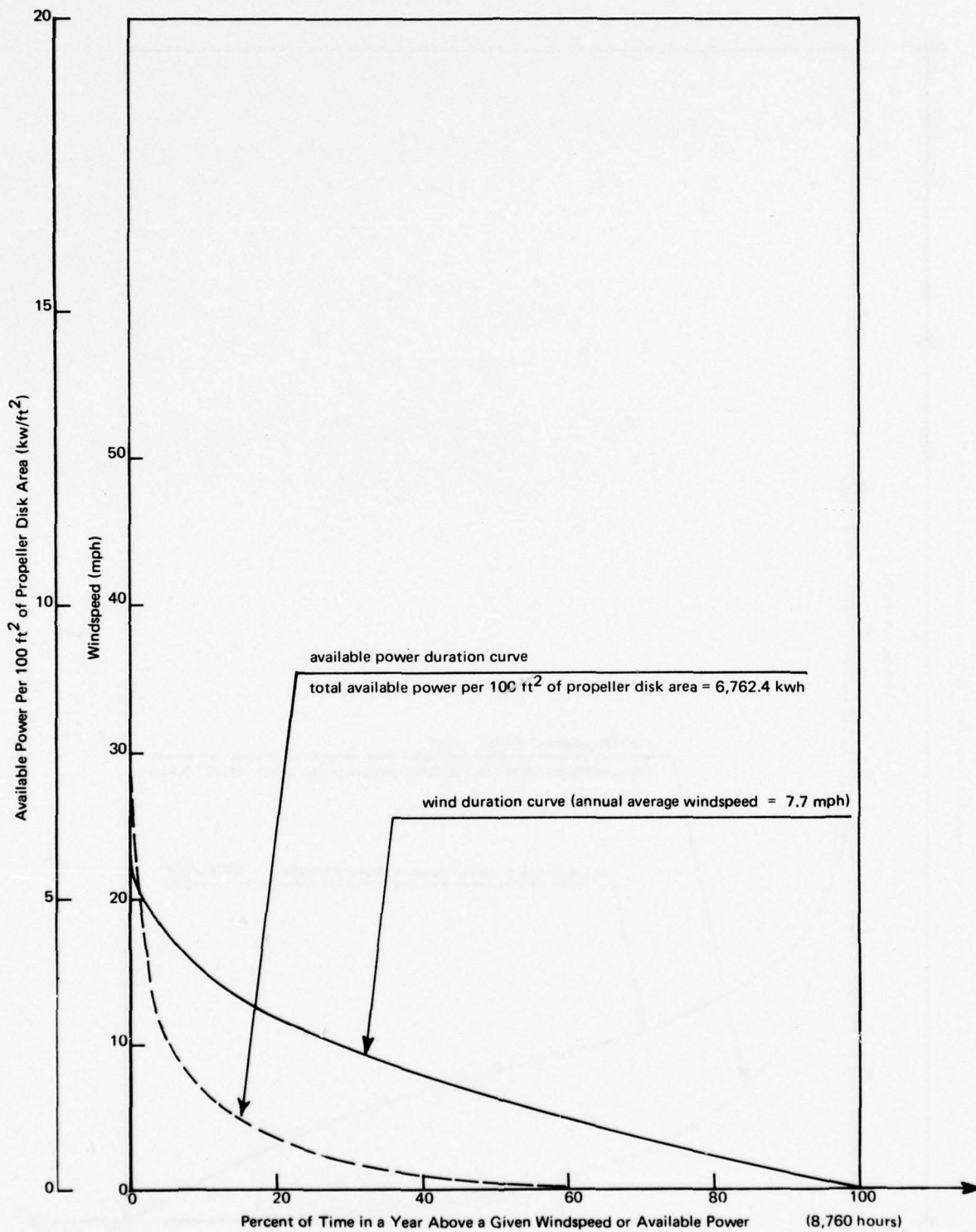

Figure 10. Windspeed and power duration curves for a site near Portland

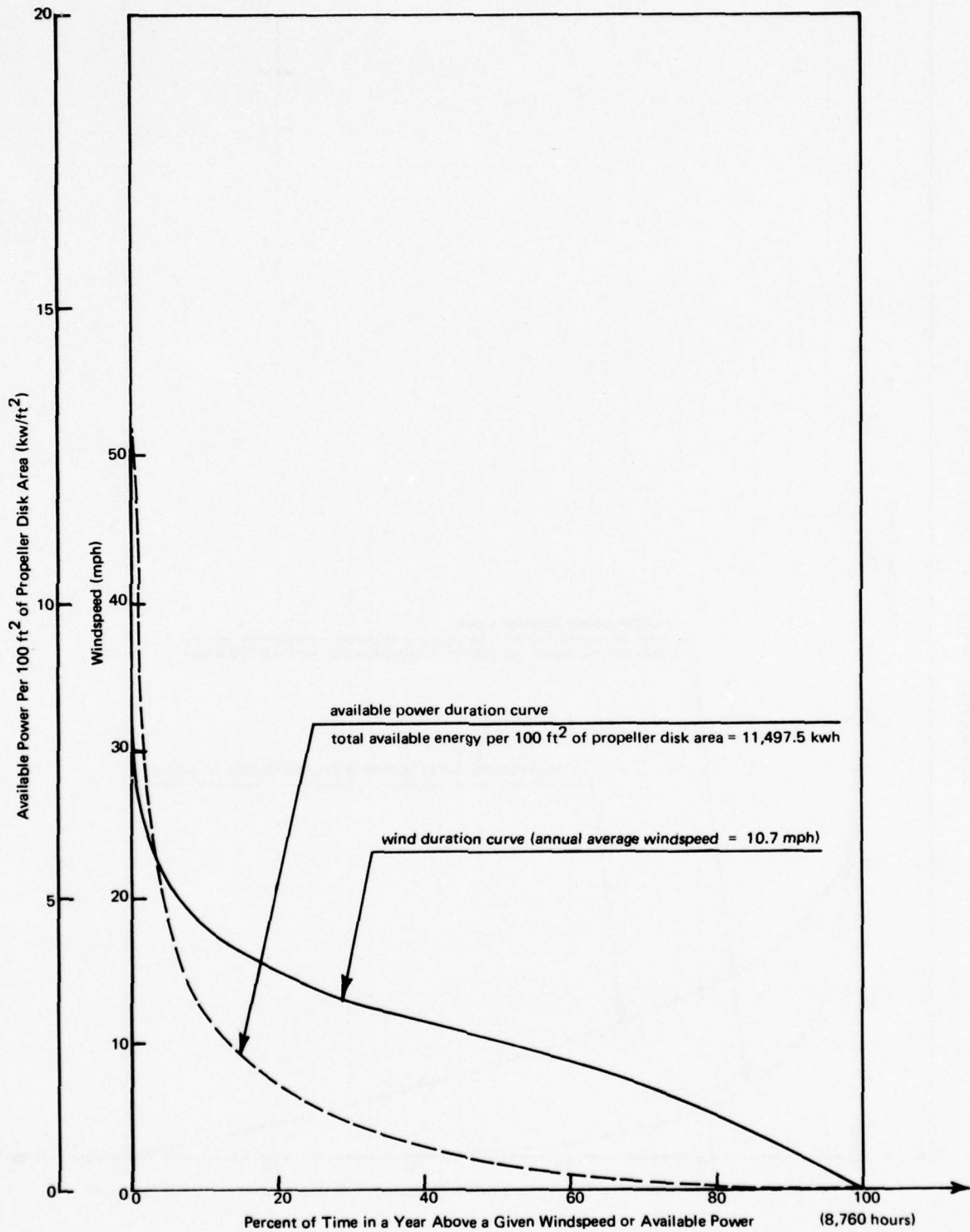

Figure 11. Windspeed and power duration curves for a site near Seattle (Tacoma Airport)

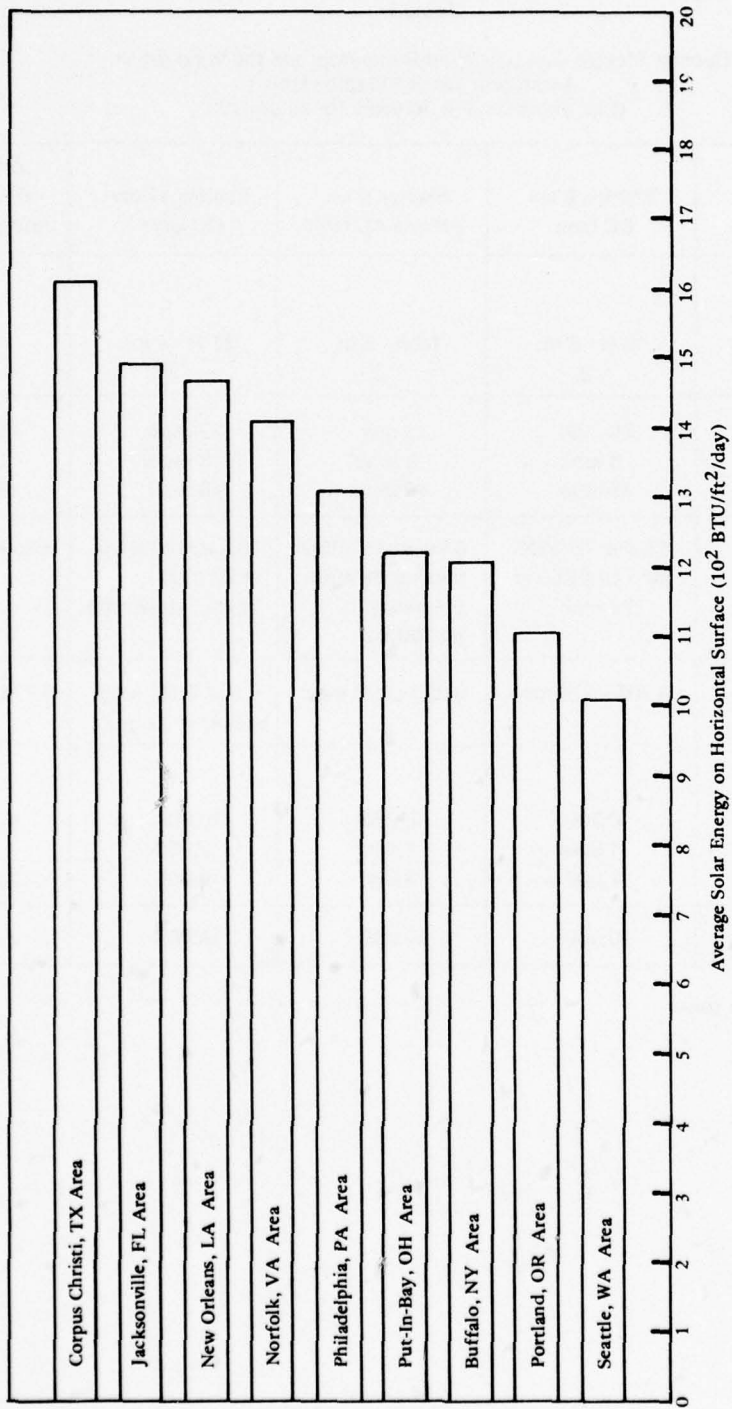

Figure 12. Daily average of annual available solar energy

Table 1

Data on Elektro G.m.b.h. Wind Generators and the Wind-driven
Aeromotor Water Pumping Unit
(Life expectancy is 30 years for all units.)

Item	Elektro 6 kw DC Unit	Elektro 5 kw 3 Phase AC Unit	Elektro 12 kw DC Unit	Aeromotor 6-hp Water- pumping Unit
Propeller: diameter no. of blades	16 ft - 5 in. 3	16 ft - 5 in. 3	21 ft - 6 in. 3	16 ft 18
Rated Windspeed Cut-in Speed Furling Speed	26 mph 8 mph 45 mph	23 mph 8 mph 45 mph	27 mph 8 mph 45 mph	25 mph 8 mph 45 mph
Output	6 kw at 65 VDC (or 115 FCD) at 26 mph	5 kw at 110/190 VAC at 23 mph frequency 60-100 Hz	10 kw, 110 VDC at 27 mph 12 kw, at 32 mph	6 hp at 25 mph
Power Coefficient C_p	0.307 at 26 mph	0.370 at 23 mph	0.267 at 27 mph 0.200 at 32 mph	0.272 at 25 mph
Cost (\$) wind generator tower installation	6,700 1,800 2,000	6,700 1,800 2,000	10,000 2,000 2,000	5,000 ^a 2,000 2,000
Total (\$)	10,500	10,500	14,000	7,000

^aIncluding pump and tower

Table 2

Sample^a of Predicted Monthly and Annual Performance of the 5-kw Elektro Wind Generator
(Mean monthly output of the unit = 901 kw-hr)

Performance Parameter	Jan	Feb	Mar	Apr	May	Jun	Jul	Aug	Sep	Oct	Nov	Dec	Annual
Available Energy, kw-hr	3701	3396	4291	3369	2342	2150	1935	1738	2055	2345	3194	3658	35,209
Output, kw-hr	1130	1040	1175	1015	790	725	665	595	690	765	975	1110	10,815
Specific Power Output, kw-hr per kw-yr	226	208	235	203	158	145	133	119	138	153	195	222	2,163
Average Power Coefficient	0.305	0.306	0.274	0.301	0.337	0.337	0.344	0.342	0.336	0.326	0.305	0.303	0.307
Maximum Energy Excess or Deficiency of Above or Below the Monthly Mean and the Months in Which it Occurs.	0	0	276	0	0	0	0	-306	0	0	0	0	0

^a Buffalo, New York.

Table 3

Summary of the Total Annual Output and the Specific Power Output
of the Three Elektro Wind Generators for all the Nine Sites

Location	Annual Average Windspeed (mph)	5-kw, 3-Phase AC Unit		6-kw DC Unit		12-kw DC Unit	
		SPO ^a	Output kw-hr	SPO	Output kw-hr	SPO	Output kw-hr
Buffalo	12.4	2163	10,815	1849	11,094	1605	19,260
Galveston	12.5	2015	10,075	1768	10,609	1533	18,396
Seattle	10.7	1637	8,185	1387	8,322	1196	14,352
Detroit	10.3	1367	6,835	1153	6,918	992	11,902
Norfolk	10.2	1422	7,110	1145	6,870	985	11,820
Mobile	10.0	1276	6,380	1076	6,456	926	11,112
Philadelphia	9.6	1218	6,090	1028	6,167	885	10,620
Portland	7.7	873	4,365	804	4,823	693	8,316
Savannah	8.4	823	4,150	689	4,134	591	7,092

^aSPO = units of kw-hr per kw-yr.

Table 4

Equipment and Installation Costs of Electrical Output
 Produced by Elektro Units
 (The initial costs per kw-hr do not include the interest on the capital.)

Location	6-kw DC Unit (\$/kw-hr)	5-kw, 3 Phase AC Unit (\$/kw-hr)	12-kw DC Unit (\$/kw-hr)
Buffalo	0.0317	0.0323	0.0243
Galveston	0.0330	0.0347	0.0253
Seattle	0.0420	0.0427	0.0327
Detroit	0.0507	0.0513	0.0393
Norfolk	0.0510	0.0493	0.0393
Mobile	0.0543	0.0550	0.0420
Philadelphia	0.0567	0.0573	0.0440
Portland	0.0727	0.0803	0.0560
Savannah	0.0847	0.0843	0.0657

Table 5

Local Source Data on Daily Averages of Solar Energy for Selected Sites

Time	Langleys/Day for following sites --									
	Galveston District (Corpus Christi, TX Data)	Savannah District (Jacksonville), FL Data)	Mobile District (New Orleans, LA Data)	Norfolk District (Norfolk, VA Data)	Philadelphia District (Philadelphia, PA Data)	Detroit District (Put-in-Bay, OH Data)	Buffalo District (Buffalo, NY Data)	Portland District (Portland, OR Data)	Seattle District (Seattle, WA Data)	
Jan	262	267	237	208	175	126	110	90	70	
Feb	330	346	296	270	242	204	201	162	124	
Mar	413	423	393	372	347	302	282	270	244	
Apr	474	514	479	477	425	386	366	375	360	
May	561	556	539	540	493	468	506	492	446	
Jun	604	525	549	572	554	544	573	469	471	
Jul	629	522	502	550	538	561	550	539	501	
Aug	558	476	491	481	465	487	465	461	431	
Sep	470	383	418	398	388	382	377	354	310	
Oct	408	331	389	310	293	275	250	209	174	
Nov	285	274	269	223	191	144	138	111	90	
Dec	240	230	220	184	152	109	110	79	59	
Annual Langleys	436	404	399	382	355	332	327	301	273	
Annual BTU/ft ²	1609	1491	1472	1410	1310	1225	1208	1111	1007	

APPENDIX F: NOTATION

A	Disk area through which fluid (wind or water) is moving
A'	Surface area under consideration, ft^2
A _P	Projected (in the current direction) area
C	Wind-power constant evaluated from long-term wind data
C _P or C _P ^(V)	Wind-power coefficient
c	Specific heat of substance
dt	Temperature differential
E	Energy
E _w	Total energy output
F	Frequency of the grid supply
G	Amount of water stored, gal
g	Acceleration of gravity (32.2 ft/sec^2)
H _s	Significant wave height, the average height of the highest third of the waves
h _{conv}	Convective heat transfer coefficient, $\text{Btu/hr-ft}^2\text{-}^\circ\text{F}$
m	Mass of substance
N	Design speed of the grid motor
P	Atmospheric pressure, lb/in.^2
P'	Number of poles in the field winding of the grid supply
P _a	Partial pressure of water vapor in air at air temperature (t_a), lb/in.^2
P _C	Power potential of water currents
P _{rated}	Rated output of wind machine using power duration curves
P(t)	Wind power per unit time
P _w	Vapor pressure of water at water temperature (t_w), lb/in.^2
P _{w'}	Power per foot of wave front width, kw
P _w (t)	Instantaneous power output of a wind machine
Q	Energy, Btu
RA	SR _i /SE _h ratio
SE _h	Average daily solar radiation received on a horizontal surface, ly/day

SE_o	Average daily extraterrestrial solar radiation received on a horizontal surface, ly/day
SPO	Specific power output, the ratio of the total annual output of the wind-power plant to its rated output
SR_i	Average daily solar radiation received on a south-facing surface (angle from horizontal), ly/day
s	Slip of the grid supply
T	Time period
T'	Wave period
TA	Time adjustment, min
t	Time
t_f	Final temperature of substance, °F
t_i	Initial temperature of substance, °F
U	Mean windspeed
V'	Heat of vaporization of water, Btu/lb
V	Windspeed
V(t)	Windspeed at given instant of time t
v	Current velocity
W	Humidity ratio
W'	Width of wave front
Z	Amount of water vapor in lb/hr
γ	Weight density of fluid (62.4 lb/ft ³ for fresh water and 64 lb/ft ³ for seawater)
ϵ	Energy dissipation rate in ft ² /sec
η	Overall efficiency
ρ_a	Mass density of air
ρ_w	Mass density of fluid (2 lb-sec ² /ft ⁴ for seawater)
$\phi(U, T)$	Energy pattern factor
$\phi_A(U)$	Asymptotic value of $\phi(U, T)$

In accordance with letter from DAEN-RDC, DAEN-ASI dated 22 July 1977, Subject: Facsimile Catalog Cards for Laboratory Technical Publications, a facsimile catalog card in Library of Congress MARC format is reproduced below.

Parker, C E

Identification of alternative power sources for dredged material processing operations / by C. E. Parker ... et al., Civil Engineering Laboratory, Naval Construction Battalion Center, Port Hueneme, California. Vicksburg, Miss. : U. S. Waterways Experiment Station ; Springfield, Va. : available from National Technical Information Service, 1977.

60, c77, p. : ill. ; 27 cm. (Technical report - U. S. Army Engineer Waterways Experiment Station ; D-77-32)

Prepared for Office, Chief of Engineers, U. S. Army, Washington, D. C., under DMRP Work Unit No. 5C08.

Includes bibliographies.

1. Alternate energy sources. 2. Dredged material disposal. 3. Hydraulic power. 4. Solar energy conversion. 5. Wind power. I. United States. Army. Corps of Engineers. II. United States. Civil Engineering Laboratory, Port Hueneme, Calif. III. Series: United States. Waterways Experiment Station, Vicksburg, Miss. Technical report ; D-77-32.

TA7.W34 no.D-77-32

IDENTIFICATION OF ALTERNATIVE POWER SOURCES
FOR
DREDGED MATERIAL PROCESSING OPERATIONS

APPENDICES A-E

TR D-77-32

APPENDIX A: WIND POWER ANALYSIS METHODOLOGIES
AND CONVERSION SYSTEMS

Analysis Methodologies

Wind energy calculations

1. The instantaneous power available in the wind is the kinetic energy per unit time of a column of air moving undisturbed through a finite disk area. Explicitly, the power $P(t)^*$ is

$$P(t) = \frac{1}{2} \rho_a A V^3(t) \quad (A1)$$

where ρ_a = the mass density of air

A = the disk area through which the wind is blowing

$V(t)$ = the windspeed at a given instant of time t

In Equation A1, the changes in the ambient air density ρ_a due to daily and seasonal temperature variations are considered to be small; thus, these changes will be considered as independent of time at a given location. Integrating Equation A1 over time t yields the energy available in the wind over an arbitrary period of time (e.g., T). Thus, the energy E is

$$E = \int_0^T P(t)dt = \frac{1}{2} \rho_a A \int_0^T V^3(t)dt \quad (A2)$$

Since $V(t)$ is available as a set of numbers, E is generally obtained by numerical evaluation of the integral. A standard numerical integration technique, such as trapezoidal rule, yields fairly accurate results.

2. A wind machine can convert only a fraction of the available power into the shaft output, thus implying that the expression of Equation A1 must be multiplied by a conversion factor to obtain the power

* For convenience, symbols and unusual abbreviations are listed and defined in the Notation of Appendix F.

output of the wind machine. The theoretically limiting value of the conversion factor for a propeller machine is 0.593. Thus, the instantaneous power output of a given wind machine at $V(t)$ is

$$P_w(t) = \frac{1}{2} C_p(V) \rho_a A V^3(t) \quad (A3)$$

where the factor $C_p(V)$ is called the "power coefficient" of the machine. For a conventional propeller machine, depending upon the windspeed $V(t)$, $C_p(V)$ varies from 0.4 to 0. Finally, the total energy output E_w of a wind machine over a time period T is

$$E_w = \frac{1}{2} \rho_a A \int_0^T C_p(V) V^3(t) dt \quad (A4)$$

3. Further, the power coefficient $C_p(V)$ for a given wind machine is easily obtainable from its design and performance characteristics by solving Equation A3 for $C_p(V)$. As an example, $C_p(V)$ for a commercially available 5-kw wind generator was computed; the results appear in Table A1. A plot of $C_p(V)$ versus V for the same machine is shown in Figure A1. The values of $C_p(V)$ for windspeed values at or below 7 mph are zero because the wind machine has a cut-in speed of 8 mph. The machine starts producing the full output of 5 kw at a windspeed of 23 mph and has a furling (shut-down) speed of 45 mph to protect it against storms and gales.

4. Specific power output (SPO) is a commonly used variable for evaluating the performance of wind machines. For a given location it is defined as the ratio of the total annual output of the wind-power plant to its rated output. Since the annual output is generally measured in kw-hr and the rated output of the machine is specified in kw, the SPO is stated in units of kw-hr/kw-yr. By analytically using Equation A4, SPO for a wind machine installation is given by

$$SPO = \frac{1}{2} \rho_a A_o^T C_p(V) \int V^3(t) dt \quad (A5)$$

P_{rated}

where P_{rated} is the rated output of the machine using power duration curves. The integral in Equation A5 can be evaluated numerically. Physically, the SPO for a given installation indicates the number of hours of rated output operation in a year. A high value of SPO indicates a good installation while a low SPO implies poor installation. Thus, the SPO plays an important role in appraising a site for wind power installation.

Windspeed and power duration

5. Existing surface wind data in the form of windspeed, usually given in miles per hour or knots, are measured by an anemometer, with observations made each hour. Another way of presenting wind data for a given location is to prepare drawings of monthly or annual frequency distribution of windspeed and direction, called "wind roses." The wind data are compiled as percentage frequency of windspeed and direction groups. To a wind-energy analyst the frequency of wind direction at a given location may be important in siting a given wind machine, but for estimation of the output of the machine at the location over a certain period of time, the wind direction is of little importance. Thus, for this study, the wind data for each site are listed as a total of frequencies for all directions. Table A2 is an example of the format of the historical wind data available from National Climatic Center. The data are given by the month and the year as a percentage of frequency of windspeed in a given speed or range. The data in the tables were based on the observations taken during 1951 to 1960.

Descriptions of Conversion Systems

6. The windmill-driven reciprocating pumps generally are designed to handle relatively small amounts of water at high lifts for transferring the water to elevated tanks. At dredged material containment

sites, pumping systems capable of transferring large quantities of fluid against low to moderate heads are required. Most of such pumping units are required to handle headed water containing a wide variety of solids, including silts, clays, and inorganic matter. Further, if such pumps were driven by wind-power sources, they would operate under variable input torque. Generally, the variable torque input to the pump shaft results in a variable speed operation which in turn causes higher losses of energy. Presently, no off-the-shelf pumping hardware is suitable for pumping muddy water and, at the same time, compatible with the wind turbine output. However, wind-generated electricity offers more flexibility in operating equipment and systems at the sites.

7. Another factor to be considered while applying wind power at the dredged material site is construction cost of installing the wind-power installation. At most sites, locating a wind-power system may require special foundation design due to the poor bearing capacity of the local soil. Special construction features may result in additional costs and thus raise the cost of the power produced on a per kilowatt-hour basis. Additional research is necessary to fully assess the practical utilization of wind power at dredged material sites.

8. For dewatering dredge containment sites comprised mostly of sand, the conventional pump designs of either the reciprocating or the centrifugal type may suffice. Price Island in the Portland District (Appendix D) is an example of such a site, which occupies a land area of about 120 acres. Preliminary calculations show that two 16-ft-diam Aeromotor pumping units are enough for dewatering the Price Island site.

9. Sectorov⁴ suggested that to use wind power for water pumping and irrigation installation, it is generally most convenient to operate the centrifugal pump electrically from the output of a wind generator. Such an arrangement ensures nearly constant-speed operation of the pump without deteriorating its efficiency. Also, direct conversion of wind energy into electricity offers more flexibility in its usage. For

example, if the electro-osmosis method of dewatering is applied at a site, the wind-generated electricity may be used for the electrodes and for operating the water pump simultaneously.

10. Because of the random nature of the wind, an AC generator driven by a wind-powered rotor will deliver electricity with variable voltage and frequency. The variable frequency power, if supplied to a motor driving the water lift pump, will operate it at irregular speeds. To keep the cost of the energy produced low, it is essential to fully utilize the output from the wind generator. That is, utilization of the generated power between cut-in and rated speed must be done by matching the load to the generator's momentary capacity. Thus, to follow the generator's output versus windspeed characteristics over its entire operating range, the available load should be infinitely variable. In practice, however, the infinitely variable load is almost impossible to obtain. One convenient way is to divide the available load into a series of small units and switch them in and out of the circuit to match the generator's instantaneous output. Such a scheme requires an automatic switching device for applying the load to the generator circuit. One such system employs electromechanical relays for load switching and is now under development at CEL, as shown in Figure A2. The switching relays used are controlled by an electronic logic circuit actuated by the generator output. In the operation of the switching device, the plots of Figure A3 show that the various switching sequences are a function of the generator output frequency for a five-step switching device. The schematic also shows that a rectifier converts the output of the 3-phase AC generator into a DC power required by the electrodes of the electro-osmosis process. The loads L1, L2, etc., refer to a bank of electrodes at convenient locations at the site. In fact, the concept of the switching devices discussed can be easily extended to a system for sharing the load with the existing utility or other source of electricity simply by using two-position relays as shown in Figure A4. An

additional rectifier is required on the utility line to obtain DC electricity. During the period the wind generator is inoperative, the electrodes are supplied by the utility power and when the wind is blowing above the cut-in speed of the wind generator, the switching device connects the optimum number of electrodes to the generator. This arrangement provides an efficient use of the wind generator's output while maintaining continuity of power to the electrodes. One of the loads in the schematic of Figure A2 may be the motor of a pump required to lift water after it is collected at the cathode. The power input to the pump motor may be AC and need not be rectified. A concept to accomplish constant speed operation of an AC motor operated on the variable output of the wind generator will be discussed next.

11. Figure A5 is a schematic of a system for mixing the grid and the wind-generated power mechanically to drive a centrifugal pump at constant speed. The pump is driven by two motors coupled to its shaft. One motor is a variable pole-induction motor connected to the grid line. Irrespective of the windspeed, the pump operates at a constant speed corresponding to the design speed of the grid motor given by

$$N = 120F(1-s)/P' \quad (A6)$$

where F = the frequency in Hz of the grid supply

s = the slip, which usually varies from 0.02 to 0.10 depending on the motor size

P' = the number of poles in the field winding

The arrangement locks the wind-generator rotor to a speed corresponding to N . Thus, the changes in windspeed will result in a variable tip-speed-to-windspeed ratio of the rotor. For maximum efficiency, most commercial wind machines must operate at a fixed tip-speed-to-windspeed ratio. Hence, the rotor of a wind machine must turn at variable speed to maintain its tip-speed-to-windspeed ratio close to its rated value. One method of optimizing this ratio is to allow a discrete change in the

rotor speed in various steps by changing the poles on the motor at some preselected windspeeds. The pole changing can be done by an automatic switching device of the type discussed earlier. The concept being discussed uses four or five different pole pairs in the range between the cut-in and the rated speed of the rotor. In practice, doubling the number of poles can be done by a simple parallel circuit scheme. Further investigation, however, is required to prove the practicability of the method.

12. Another system for dewatering dredged material processing sites is shown schematically in Figure A6. The system is simple and uses off-the-shelf components. The lifting of the water is done by a positive displacement device of reciprocating type, such as a diaphragm pump. To utilize the wind machine output efficiently, a set of two holding tanks is provided: as one is emptied, the other stores the water being lifted. The system has a special advantage in that the lift pump never comes in contact with the water being lifted. The various valves on the lines are electrically operated through some type of level sensor in the holding tanks. The lift pump is driven by a wind machine through a mechanical coupling. The practicality of the system should be determined through field tests at a site where dewatering is a definite problem (e.g., at Mobile).

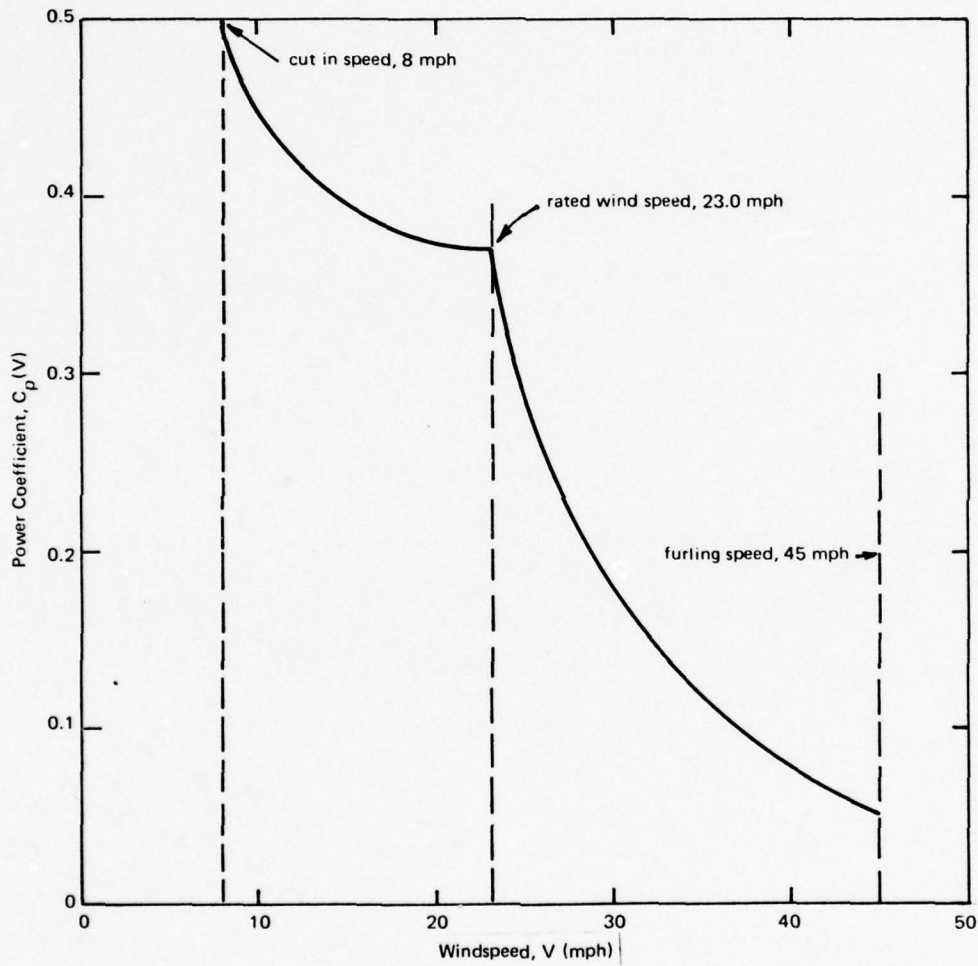

Figure A1. Power coefficient $C_p(V)$ versus windspeed V for the 5-kw wind generator

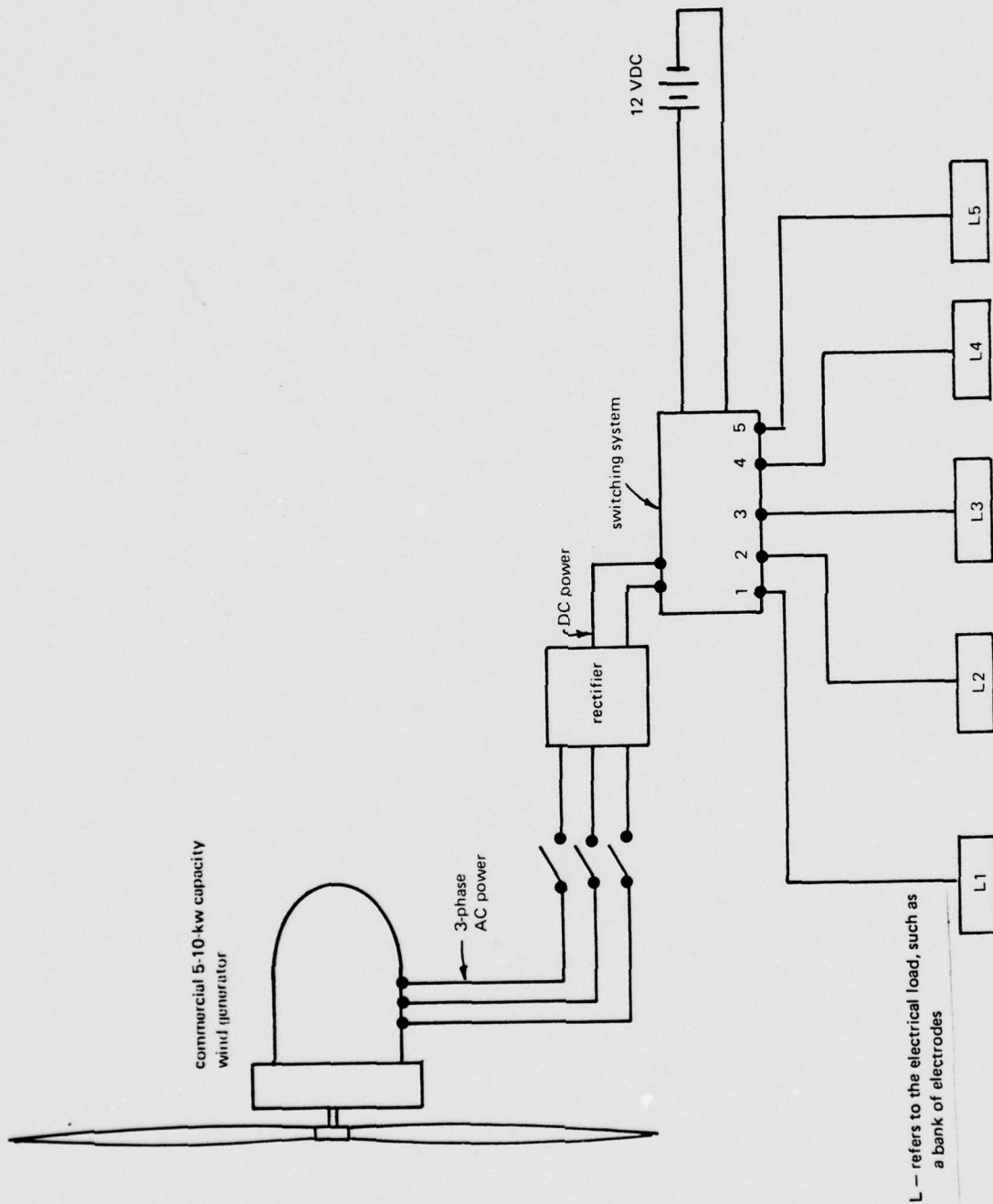

Figure A2. Operating a 3-phase AC wind generator with an automatic switching device for electro-osmotic dewatering

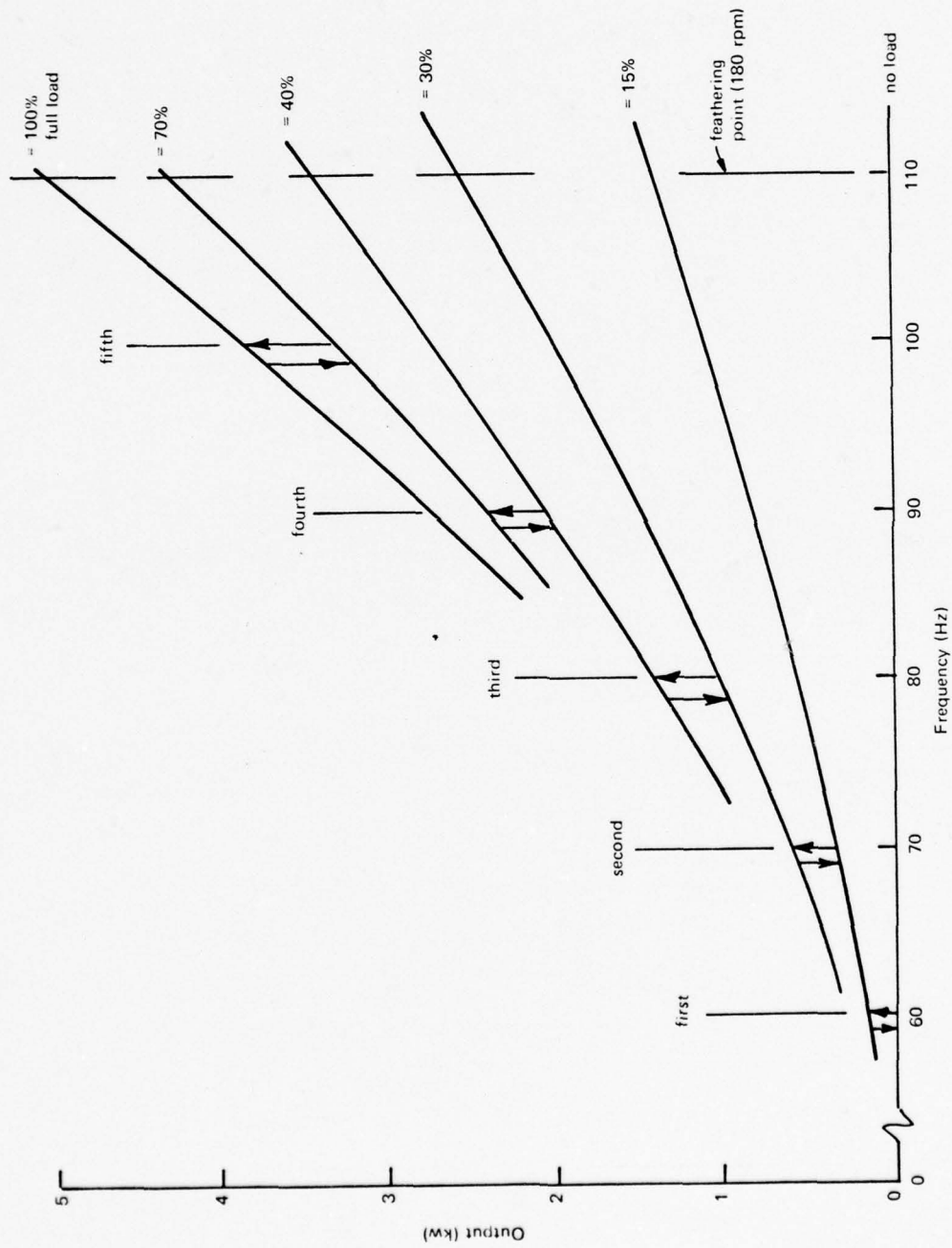

Figure A3. Characteristics of 5-kw electro wind generator and switching system for optimal usage of wind energy

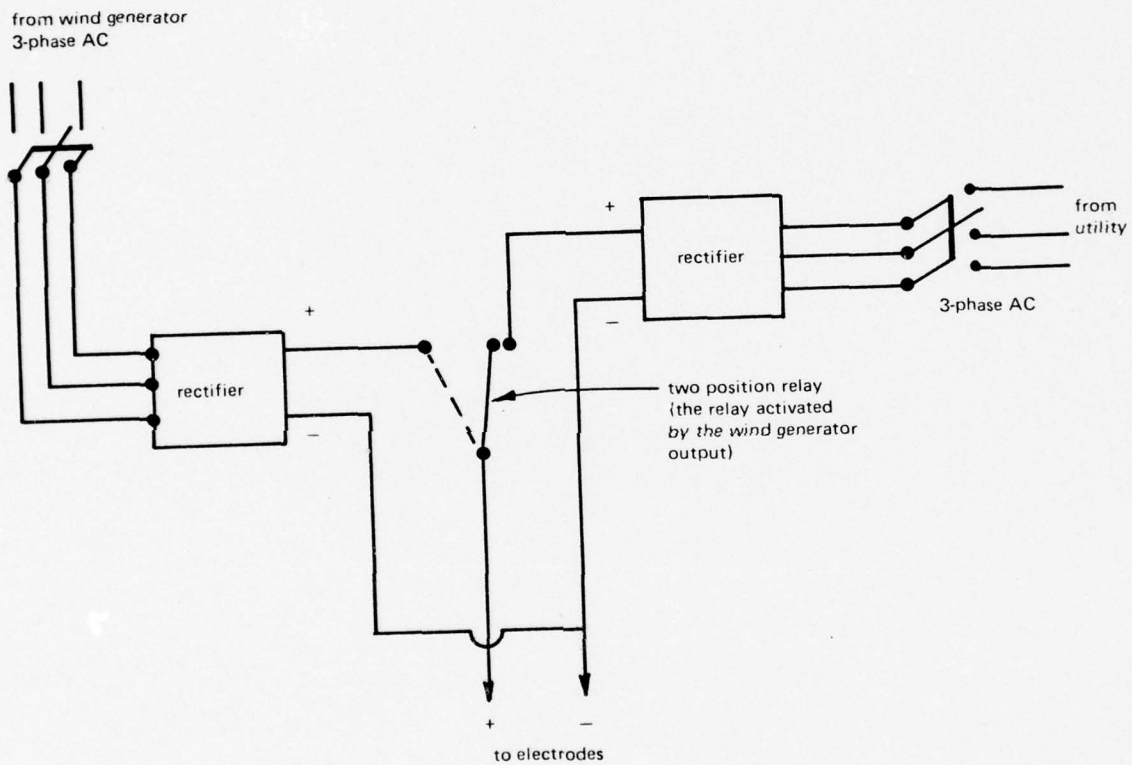

Figure A4. Sharing wind-generated power with commercial power for continuous electro-osmotic dewatering

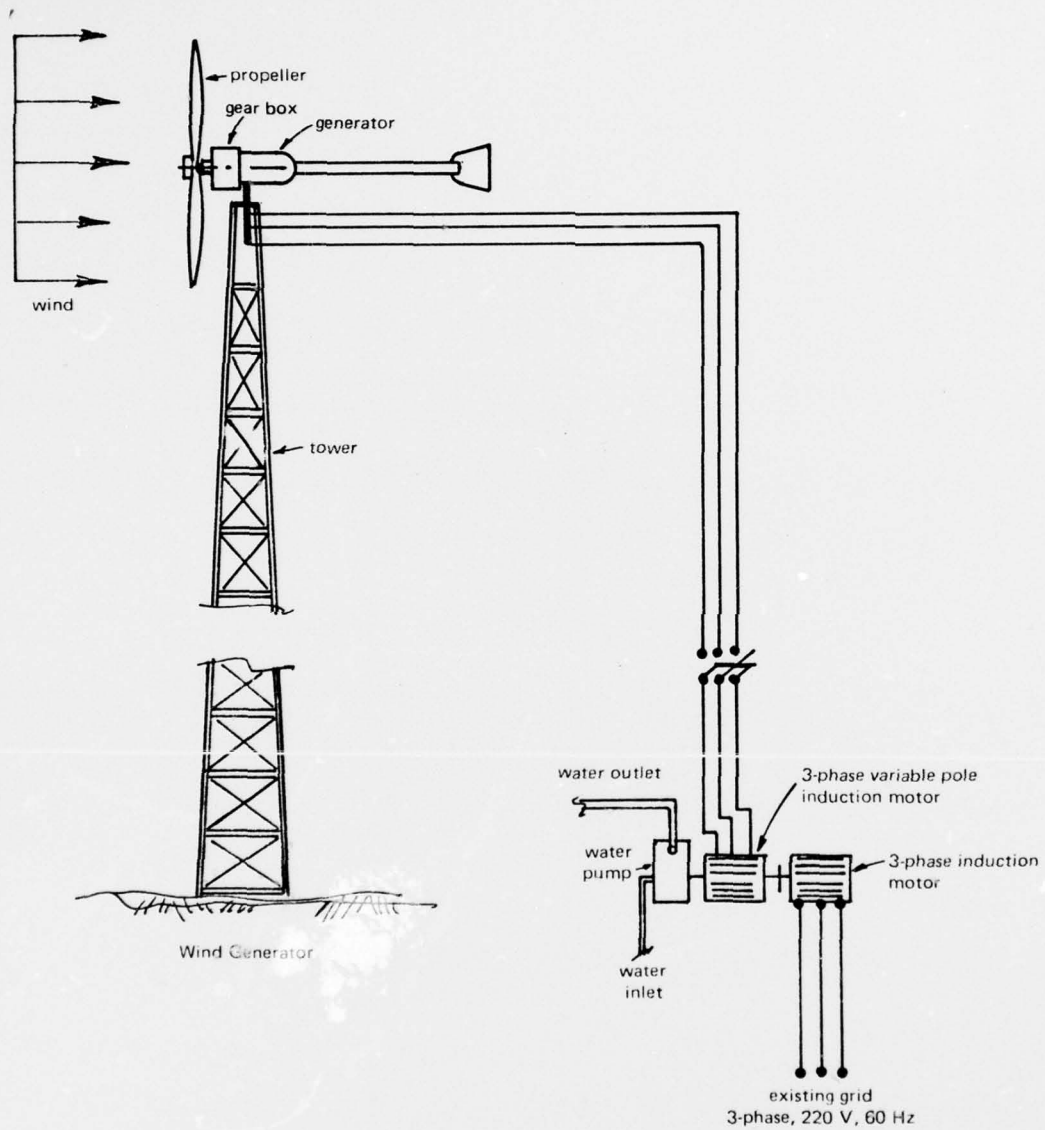

Figure A5. Method of using wind-generated power with grid power for pumping water at constant speed

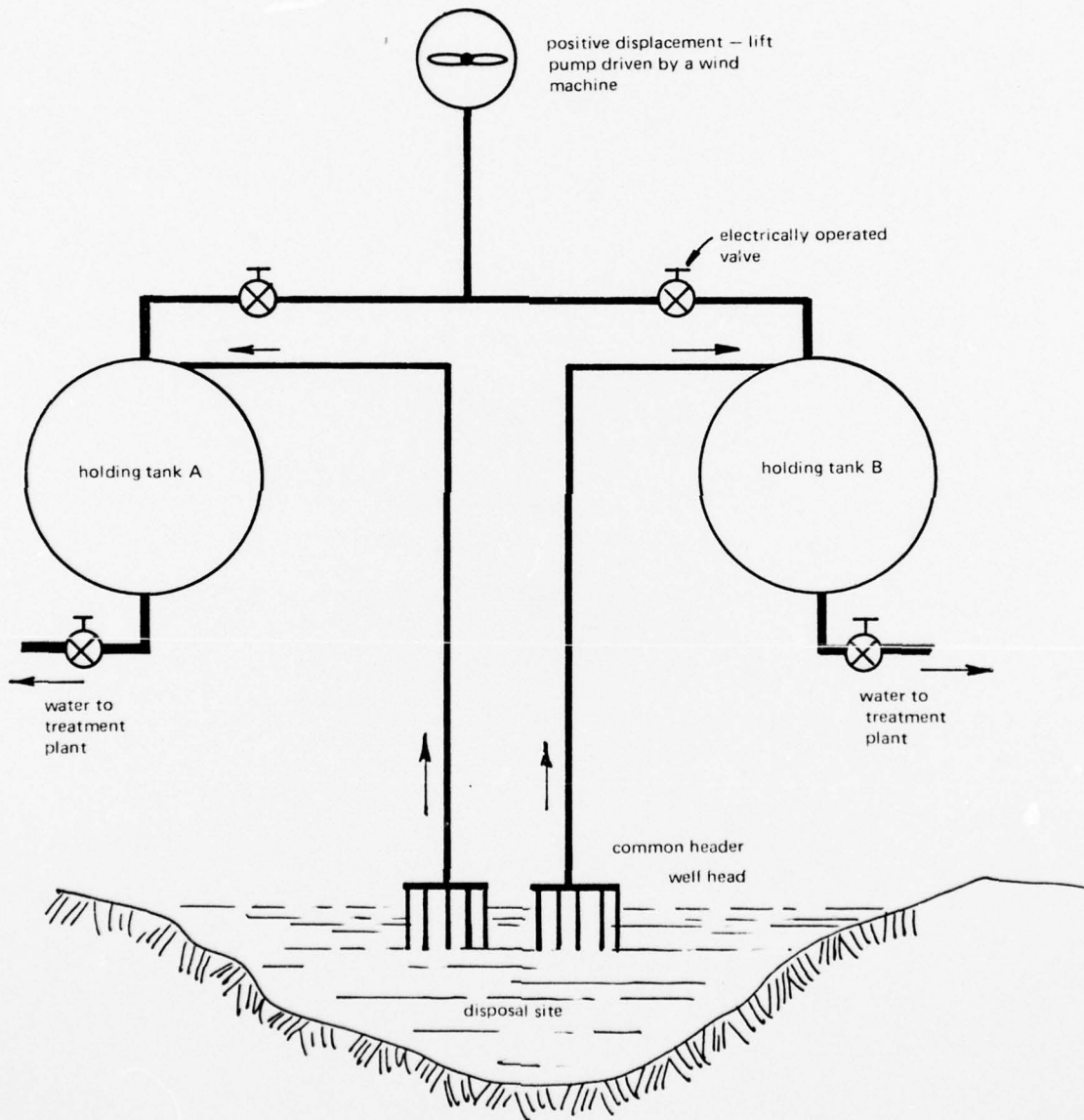

Figure A6. Windmill-driven diaphragm pump system for dredged material dewatering

Table A1

Power Coefficient $C_p(V)$ for a 5-kw Commercial Wind Generator for Various Windspeeds

Windspeed, mph	Power Coefficient, $C_p = \frac{P_W(t)}{\frac{1}{2}\rho_a AV^3(t)}$
0	0
3	0
7	0
10	0.443
12	0.417
15	0.390
18	0.376
23	0.370
24	0.343
31	0.163
38	0.09
46	0

Table A2

Frequencies of Windspeed in the Vicinity of Buffalo, New York

Month	Frequencies (%) Based on Hourly Observations of Windspeed at Following mph - -										Average Wind-speed (mph)
	0-3	4-7	8-12	13-18	19-24	25-31	32-38	39-46	47 Over	Total	
January	4	13	30	30	17	5	1	+	+	100	13.5
February	3	12	30	32	17	5	1	+	0	100	13.9
March	4	13	30	28	16	6	2	1	+	100	14.1
April	6	16	29	28	15	5	1	+	+	100	13.2
May	5	18	36	27	11	2	+	+	0	100	11.9
June	5	19	38	25	10	2	+	+	+	100	11.6
July	7	21	37	24	9	1	+	0	0	100	11.1
August	8	23	39	22	7	1	+	+	0	100	10.5
September	6	20	39	24	9	2	+	+	0	100	11.1
October	5	20	39	23	10	3	+	+	+	100	11.5
November	4	15	32	27	15	4	1	+	+	100	13.3
December	4	15	28	29	17	5	1	+	+	100	13.5
Annual	5	17	34	27	13	3	1	+	+	100	12.4

APPENDIX B: SOLAR ENERGY CONVERSION PROCESSES

Descriptions of Conversion Systems

Types of systems

1. Solar-chemical. In the solar-chemical conversion process, the sun's energy is directly converted into chemical energy through electronic processes within the solar collecting medium. This is the basic mechanism of photosynthesis. It provides for growth of plants, which can be consumed by various methods to provide heat, electricity, nutrition, etc. Figure B1 displays a flow diagram of a typical solar-chemical energy conversion process designed for heating application.

2. The direct solar-chemical conversion process of plant growth (requiring water) could be utilized to eliminate moisture from unwanted areas; however, this approach necessitates both planting and harvesting operations and may involve a lengthy "plant growing" period. The basic solar-chemical energy conversion process is believed to offer limited results in energy reduction of dredged material processing operations.

3. Solar-thermal. The solar-thermal conversion process is the direct conversion of the sun's energy into usable heat. (This is the basic driving force of other energy forms - wind, hydropower, ocean thermal gradients, ocean currents, etc.) This process is commonly utilized for air drying of agricultural products, heating pool water, preheating potable hot water, and providing heated air into building conditioning zones.

4. An extension of the basic solar-thermal process is use of a heated fluid to provide power for: (a) operating an engine for a mechanical drive system and (b) operating a turbine for electrical generation. This latter energy conversion is designated the solar-thermal-electric process, which is presently being investigated as the process for future large-scale electrical generation. Figures B2 and B3 show typical flow diagrams of the solar-thermal and solar-thermal-electric energy conversion processes, respectively.

5. Solar-electric. A solar-electric process, more commonly known as the photovoltaic conversion, consists of electrical energy (direct current) being produced directly upon the collector's exposure to sunlight. The energy conversion system necessitates an inverter to achieve alternating electrical current status. Figure B4 shows a typical flow diagram of this process.

6. This type of system is still much in the development stage with regard to low cost applications. Systems that are in service are very expensive but acceptable for remote site (space, ocean) applications.

Solar Energy Conversion Equipment

Solar collectors

7. Flat-plate solar collector. The basic construction components of the flat-plate solar collector are

- a. Glazing cover — transparent glass or plastic cover to transmit sunlight and minimize heat loss via convection heat transfer.
- b. Absorber plate — principal solar heat collecting surface to which fluid tubes are attached.
- c. Fluid tube — provides for passage of heat-carrying medium.
- d. Insulation — to minimize heat losses from absorber plate/ fluid tube.
- e. Casing — enclosure that houses the components.

Figure B5 depicts the components of the flat-plate collector; Figure B6 displays various cross sections that are commonly utilized in flat-plate solar collectors. Energy collection efficiency of flat-plate collectors depends upon construction and application, but will range between 40 to 90% for space cooling and low air temperature heating applications, respectively.

8. Solar concentrators. Concentrators are basically constructed with two surfaces: a reflector surface and a blackened receiving surface (fluid tube or boiler). Two major disadvantages with concentrators are their utilization of only the direct (not diffuse) component of sunlight

and their requirement that tracking devices follow the sun across the sky. Their energy collection efficiency depends upon construction and desired outlet fluid temperatures, but efficiency is generally less than 50%.

9. Solar cell. The solar cell consists of a positive-negative (P-N) junction in a semiconductor between a positive (P) layer, which contains movable positive charges, and a negative (N) layer, which contains movable electrons. When sunlight is absorbed by the cell, each photon unit of light produces a negative electron and a positive charge. Ordinarily, these would immediately recombine and result in the conversion of light to heat. However, due to the potential barrier at the P-N junction, the electrons produced by the light in the N-layer are driven to the electrode, and the positive charges produced by the light in the P-layer are driven to the other electrode. As these electrons and positive charges build up at the two separate electrodes, a potential develops and electrical current flows through the wires connecting the two electrodes. Figure B7 displays views of a typical photovoltaic solar cell.

10. Various materials are being utilized in the construction of solar cells to achieve high energy conversion efficiencies and lower manufacturing costs. Most notable of these materials are: silicon, cadmium sulfide, and gallium arsenide. To date, average energy conversion efficiency of solar cells is only about 10%.

Energy storage

11. Numerous forms of devices for storing collected sun energy are both available and currently being researched. The principal methods of energy storage discussed in this report are thermal and electrical.

12. Thermal storage is the most common and involves increasing a storage substance's temperature. Water is primary choice for thermal storage because of its ready availability and high heat capacity. Rocks provide a secondary storage selection but are chiefly used in air heating systems.

13. Electrical energy is stored principally in batteries charged during daylight hours. Several types are marketed, varying in operating life, charging rates, size, and costs. Some present day and future battery types are: lead-acid (liquid and dry), nickel-iron, nickel-zinc, nickel-cadmium, lithium-sulfur, and sodium-sulfur.

14. If batteries were to be used, they would be connected in parallel to allow low voltage charging by photovoltaic or solar-thermal-electric energy conversion devices and then would be discharged in series connection at higher voltages.

15. Fly-wheels, fuel cells, and other similar exotic energy storage devices are still in development; their applicability to dredged material processing operations is undetermined.

Ancillary equipment

16. To complete any solar energy conversion system, transmission, control and retrieval of the energy collected and stored must be considered. These topics will be briefly discussed below, with emphasis on solar-thermal system applications.

17. Transmission. The energy transmission system consists basically of: passage-ways for the heat-carrying medium and prime movers (e.g., water pump or air fan) of the heat transferring medium. Materials, size, and design of the passage-ways will be dependent upon: (a) the type of heat-carrying medium, (b) system pressure requirements, (c) corrosion particulars, (d) temperatures expected, and (e) desired flow rate capacity. For air transporting systems, plastic pipe/duct-work will satisfy expected system requirements; for liquid transporting systems, metal piping is principally utilized (plastic may be used in limited applications). Choice of metal piping - inexpensive steel to expensive copper - depends upon system design requirements.

18. Control. Controlling the operation of a solar energy conversion system is of paramount importance. The term "control" refers to switching on-off or modulating prime movers and terminal (energy retrieval) units. The latter are usually controlled by specifically located

temperature sensors. Temperature sensors are usually placed: (a) at the outlet of the collector system, (b) inside the energy storage medium, and (c) in the location designated for final disposition of the collected solar energy. The collector system operates when solar energy can be absorbed; the retrieval system activates when collected or stored solar energy is needed.

19. Retrieval. Retrieving the collected or stored solar energy may require terminal equipment (heat exchanger) to transform this energy into a usable form. Fan coil units (water-to-air heat exchanger with fan assembly) are typically used to convert heat from a liquid to an airstream. Where air is heated in the solar collector and utilized directly, as in the case of enhancing dredged material dewatering, no terminal unit is required.

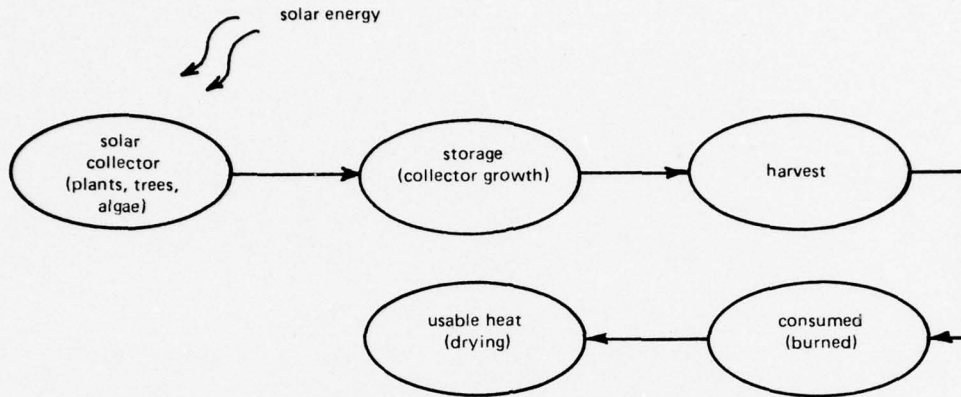

Figure B1. Typical solar-chemical energy conversion process

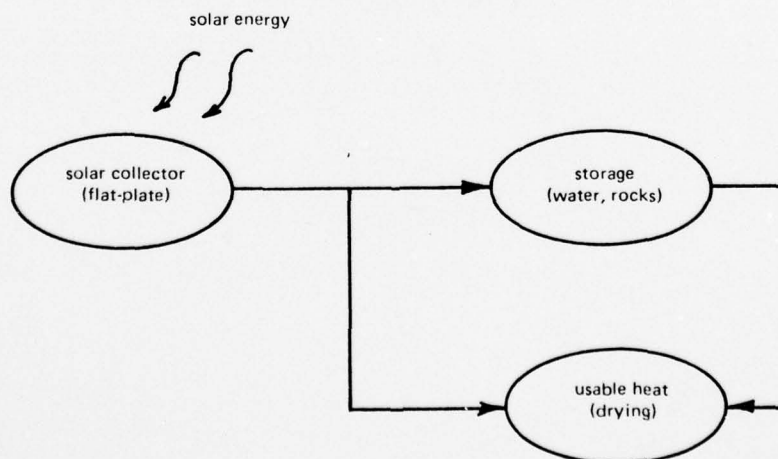

Figure B2. Typical solar-thermal energy conversion process

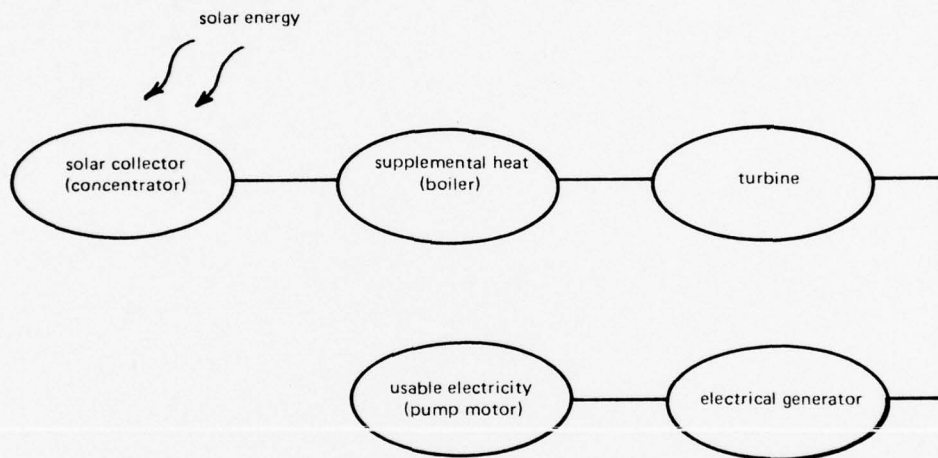

Figure B3. Typical solar-thermal-electric energy conversion process

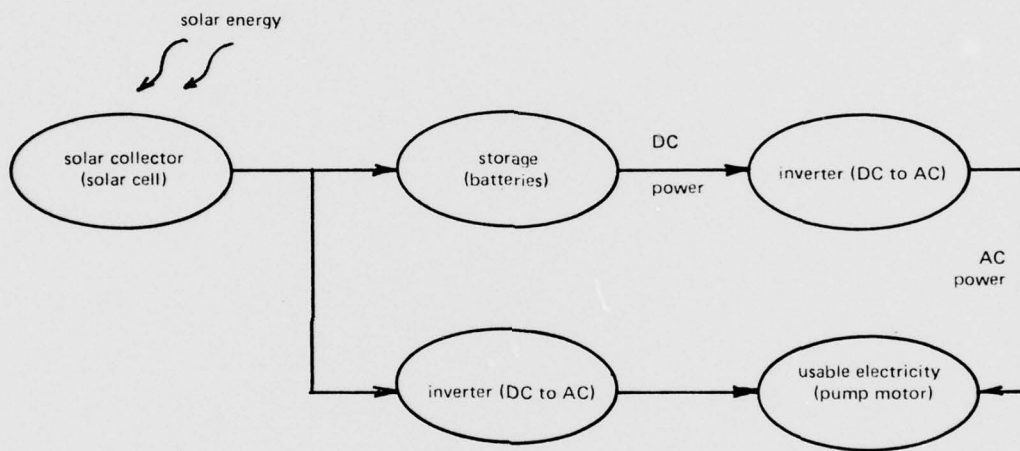
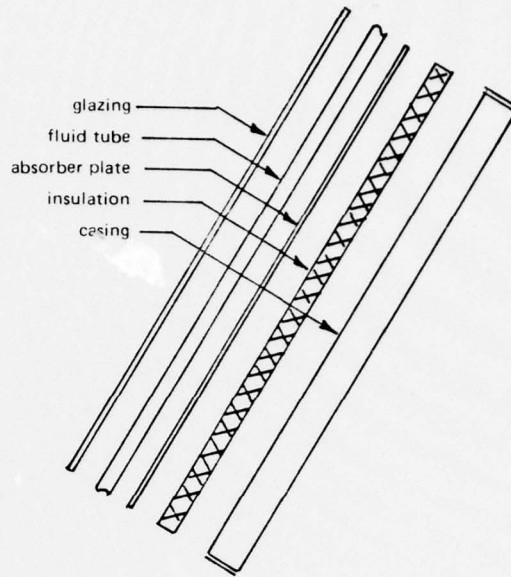
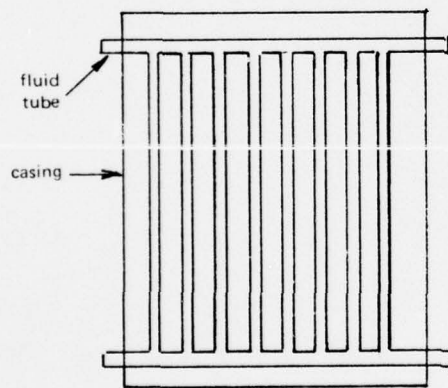

Figure B4. Typical solar-electric energy conversion process



(a) Exploded side view



(b) Plan view

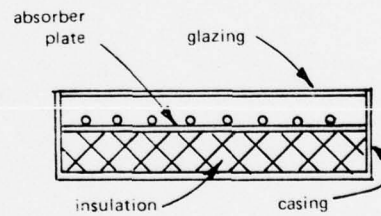

(c) Section view

Figure B5. Typical flat-plate solar collector

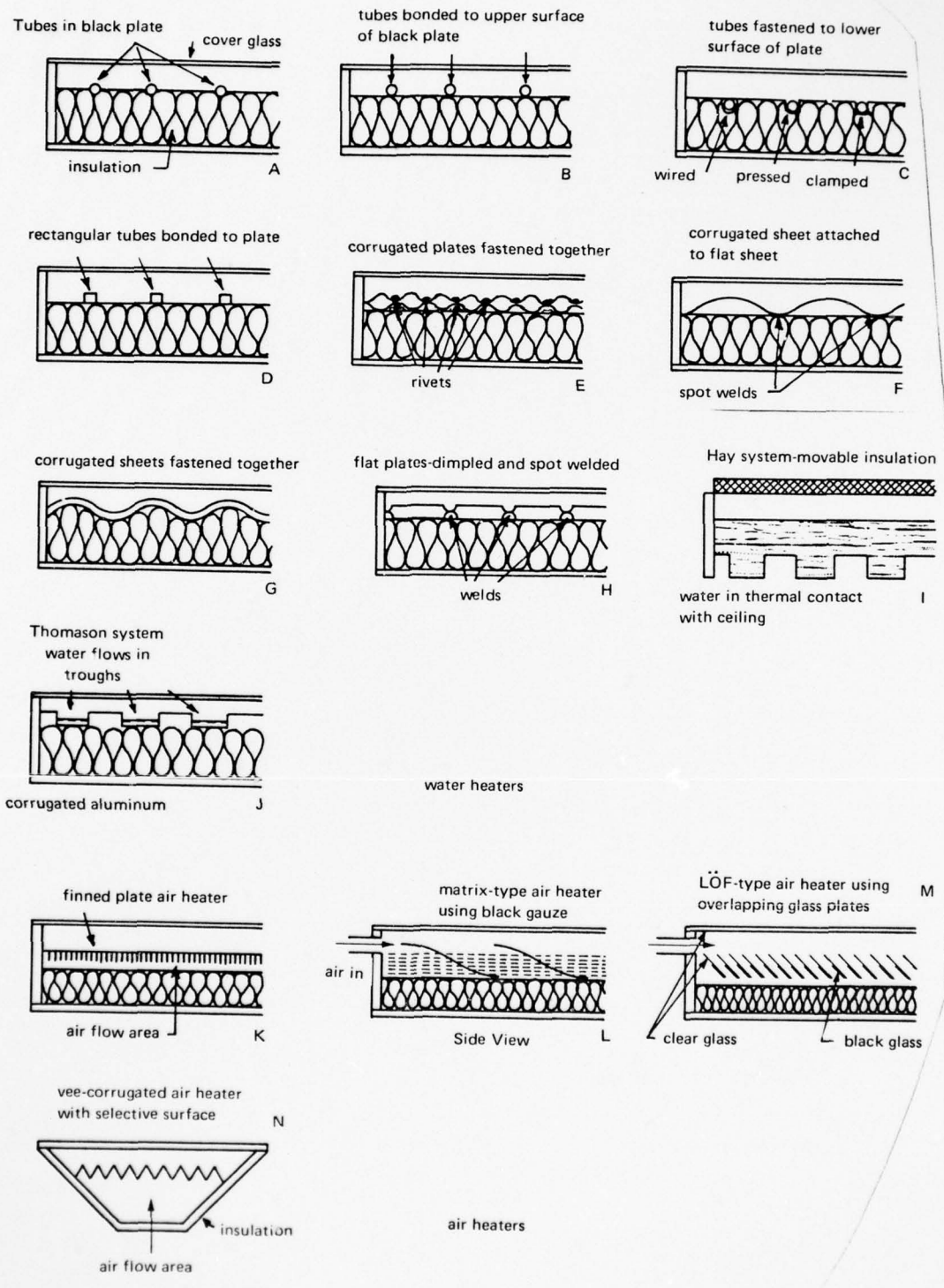

Figure B6. Various cross sections of solar collectors

AD-A048 312

ARMY ENGINEER WATERWAYS EXPERIMENT STATION VICKSBURG MISS F/G 11/2
IDENTIFICATION OF ALTERNATIVE POWER SOURCES FOR DREDGED MATERIA--ETC(U)
NOV 77 C E PARKER, D PAL, K F VODRASKA
WES-TR-D-77-32

UNCLASSIFIED

NL

2 OF 2

ADAO48312



END
DATE
FILMED
2 - 78
DDC

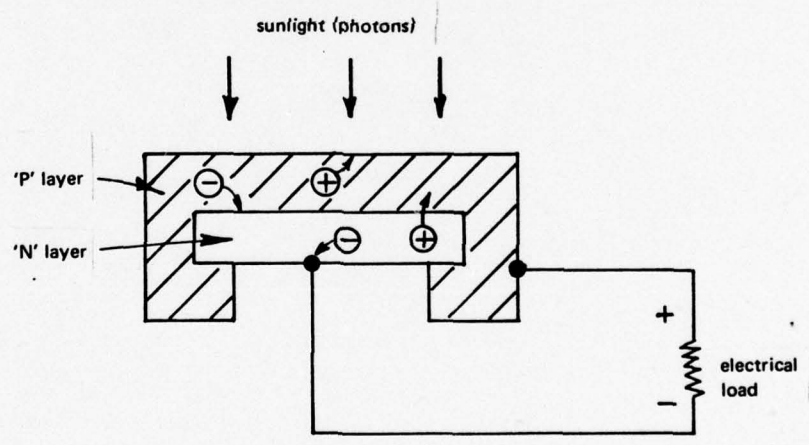
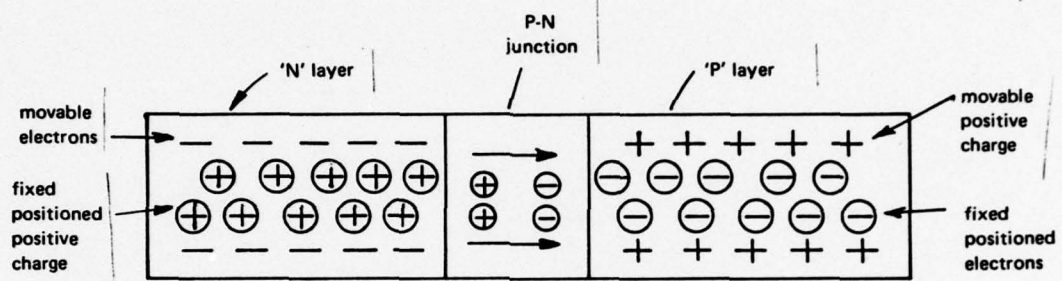

Figure B7. Typical photovoltaic solar cell

APPENDIX C: HYDRAULIC POWER ANALYSIS METHODOLOGIES
AND CONVERSION SYSTEMS

Analysis Methodologies

Wave power

1. The potential-energy-derived portion of the available wave power (the rate of transfer of potential energy when waves fall from above the still water level to below it) may be expressed as:

$$\frac{W' \rho_w g^2 T' H_s^2}{64\pi} \quad (C1)$$

where W' = width of wave front

ρ_w = mass density of fluid (2 lb-sec²/ft⁴ for seawater)

g = acceleration of gravity

T' = wave period

H_s = significant wave height, the average height of the highest third of the waves

2. The total power, including that from the kinetic energy of the water in orbital motion under the wave, is twice the power from the rate of change of potential energy.²² Therefore, for a unit width (1 ft) of wave front:

$$P_{w'} = 0.028 H_s^2 T' \quad (C2)$$

where $P_{w'}$ = power per foot of wave front width, kw

H_s = significant wave height, ft

T' = wave period, sec

3. The power that can be converted by a wave power device is equal to the total power $P_{w'}$, multiplied by the overall efficiency η .

Current power

4. The power potential of water current P_C may be expressed as:

$$P_C = \frac{A' \gamma v^3}{2g} \quad (C3)$$

where A' = the projected (in the current direction) area

γ = weight density of fluid (62.4 lb/ft³ for fresh water and
64 lb/ft³ for seawater)

v = current velocity

g = acceleration of gravity (32.2 ft/sec²)

This formulation assumes no significant elevation difference between the inflow and tail water. This assumption is generally valid for dredged material processing sites.

5. Most natural water current velocities decrease with depth. Offshore, where this decrease is fairly linear below the turbulent region near the surface, the average current speed over the depth of the submerged power plant runner may be used in the above equation to estimate the power potential. This simplification results in a conservative power estimate 5% to 10% too low.¹⁷ In other water bodies in which current speeds are not significantly influenced by the tides, the same approach (i.e., averaging the current speed between the top and bottom of the runner) is adequate, provided the reduction in current speed with depth can be considered linear, or nearly so.

6. In water bodies with tidal influence, the current speed varies with the tide from a maximum in one direction at ebb to a maximum in the opposite direction at flood. An estimate of the annual average power level for a tidal current power system at a site with high tidal currents was made by Heronemus et al.²³ These authors assumed that equipment can be built which (a) recovers energy from currents in both directions and (b) shuts off at a current velocity of about 2.1 knots. They used the

tidal current predictions published annually by the National Ocean Survey (NOS). The reader is referred to the original reference for a complete description of this analysis methodology.

7. Potential current power can be estimated using the above techniques for any site and using, for example, the data given in Table D3. The validity of these estimates is clearly dependent on the accuracy of the current speed information, which should be from points as near as possible to the locations and depths where the power generation equipment will be used. Suitable data are frequently not available for the specific site and depth of interest because (a) the surface currents are those most frequently measured or predicted and (b) surrounding landforms and the bottom significantly affect currents — tidal currents, in particular.

8. An example of a site where published data on surface currents were useful in making an estimate of power potential is Nobles Island (north of New Hampshire). Heronemus et al.²³ were able to use tidal current predictions here because the site has water depths as great as 60 ft and indications of peak current influence down to the bottom. On this basis it was assumed that a uniform current velocity distribution exists down to 25 ft. It was also possible to lay out on a chart a 100-ft-wide path in the river far enough from land that a uniform current across the path could be assumed. Therefore, a 30-ft-deep, 80-ft-wide current power system could be designed for this site using available local source data. Unfortunately, not many sites are as ideal, so current measurements must be made before power potential can be estimated.

Descriptions of Conversion Systems

Wave power systems

9. Over 50 patents have been awarded since the turn of the century for devices to extract energy from the waves.²⁴ Only those devices intended to provide power to shore are of interest here. These devices seek to extract energy from the following sources:

- A. The surge of water up the beach caused by waves,
- B. The orbital water particle motions under the waves,
- C. The vertical motion of the surface of the waves, and
- D. The pressure changes below the waves.

10. The surge system, Type A, requires storage of water to the height of the waves in a lagoon on land into which the surging water spills.²⁵ One concept of this type calls for a converging channel through the surf zone that would concentrate the waves so that a head of water is maintained in a pond at the shore end of the channel by the net momentum transport of shoaling and breaking waves.¹¹ The stored water then runs back to sea level through a turbine. This type of wave power system requires the ponding of large amounts of water on land; natural basins, or vacant land on which artificial basins can be constructed, are generally not available at processing sites. Consequently, this type of wave system is not a good option for powering equipment for processing dredged material.

11. The orbital motion system, Type B, has received much attention recently. It is a rocking vane device that is claimed to be highly efficient.²⁵ Unfortunately, this system is quite large and must be free floating. Canney²⁶ holds no hope for such a system primarily because its dimensions must be carefully controlled to match the wave environment. Thus, Type B systems are not considered promising for providing the relatively small power requirements of dredged material processing operations.

12. The surface motion system, Type C, operates near shore and usually involves a moored floating object that operates a generator onshore through a submerged linkage. Such a system can be fabricated simply and operated with available hardware and conversion equipment. However, the problems of a float on the turbulent ocean surface and moving parts in contact underwater are great. Some of these problems are alleviated by a system that replaces the moored buoyant float with a weight suspended from a shore-based boom and puts the linkage system

onshore.²⁷ Unfortunately, this system must be used at a site with a very short horizontal tidal shift to minimize the boom length.²⁶ This shoreline system's vulnerability to storms will result in much maintenance and repair, and capital cost of a system to suspend heavy weights from shore out over the waves would probably be very high. Wave motion in the horizontal plane will distort the desired vertical action of the suspended weight.²⁶ Further refinements of Type C wave power systems may relieve some of the drawbacks mentioned above, but at present such a system is not a suitable power source for a dredged material processing operation.

13. A pressure system, Type D, may be moored to the seafloor or mounted directly on it. In either case the device is below the water surface in a relatively calm and less corrosive environment. A prototype of a moored wave power device was tested and found to have an efficiency of 33%.²⁸ A bottom-mounted system uses bellows on the seafloor to apply the pressure of passing waves to the pumping of a hydraulic fluid to an accumulator and generator onshore. One system of this type uses pliable rubber-like strips filled with hydraulic fluid and encased in concrete troughs.²⁹ This system was tested on a small scale; it was claimed that almost all of the pressure change from the waves was converted to usable energy.²⁹ The simplicity of this device and its high efficiency are definite advantages, but maintenance might be troublesome.²⁶ Another disadvantage with this system is that it might cause accelerated beach erosion and deposition.

14. Although none of the wave power system types above is without drawbacks, the Type D stands out as the more viable as a power source for dredged material processing operations. As with most alternative power systems, more development is required. The design criteria (as stated in Reference 28) for wave power systems should be:

- "1. The device must operate beneath the sea surface.
2. It must have a reliable lifetime of two or more years.

3. It must be composed of the smallest possible number of moving parts.
4. All barriers against seawater penetration must be positive; no reliance upon working seals, rotating or reciprocating.
5. No operating parts shall be exposed to, or extend into, seawater.
6. The unit shall be composed, insofar as possible, of components commercially available, of proven long-life reliability.
7. The configuration must be compact and rugged.
8. The unit must produce usable power under ordinary moderate sea state conditions."

Current power systems

15. The momentum exchange devices that have been considered for the conversion of the energy in natural water currents to usable power are: (a) horizontal axis turbines with the axis parallel to the current flow, like the Kaplan turbine or open propeller; (b) horizontal axis turbines with the axis perpendicular to the current flow, like the water wheel or Savonius rotor; (c) vertical axis turbines, like the Voith-Schneider propeller; and (d) others, like an invention using a series of parachute drogues.¹⁶

16. Detailed analyses were made by Sheets¹⁷ for the Kaplan turbine, open propeller, and vertical axis turbine when used underwater in a nearly constant velocity current and by Heronemus et al.²³ for the open propeller and Savonius rotor when used at the water surface for tidal river currents. Sheets judged the vertical axis turbine superior for his application, and Heronemus et al. favored the Savonius rotor for their application.²³ These preferred current power systems are described in the following paragraphs, based on the work of References 17 and 23, respectively. Sheets considered the water wheel for submerged application and found it inferior to the other turbines he considered, but the water wheel is included in the following discussion as a potentially useful device when used at the water surface.

17. Vertical axis turbine. A vertical axis turbine is shown in Figure C1. Advantages of such a turbine for conversion of water current energy include:

- a. Neither the platform nor the turbine assembly has to be rotated relative to the current flow direction.
- b. No structure other than the blades is in the way of the current flow through the turbine runners.
- c. The turbine runners can be designed to account for current velocity differences between the top and bottom of the blades.¹⁷

18. The turbine has the following disadvantages:

- a. Reasonable estimates of water current velocities and distribution with depth (hopefully measurements) are required for design.
- b. The turbine must be larger than either the Kaplan turbine or open propeller for the same flow velocity.
- c. The design for reliable blade adjustment to account for vertical flow velocity gradients is complicated and the fabrication expensive.¹⁷

19. Savonius rotor. The Savonius rotor was developed for the measurement of water currents. This rotor is usually oriented vertically for measurement, but for extraction of current energy a horizontal orientation is considered, as shown in Figure C2. Some of the pros and cons of this rotor as a water current energy conversion mechanism are given below. Its advantages include:

- a. Its simple geometry makes it relatively inexpensive to fabricate.³⁰
- b. Operation is possible with currents that reverse direction.²³
- c. Operation does not require the damming of a water source.²³

20. The Savonius rotor has the following disadvantages:

- a. It lacks radial symmetry so the torque is not steady but varies as the rotor turns.³⁰
- b. Design of this water surface penetrating system must be very sensitive to corrosion and biofouling.²³
- c. When in the horizontal configuration shown, the rotor cannot efficiently extract energy from current in directions other than perpendicular to the axis.

21. Water wheels. Water wheels (Figure C3) were the traditional source of low power systems for centuries. Such a current power device has the following advantages:

- a. No research and development is required to make the water wheel an effective water current energy extraction device.
- b. The fabrication and maintenance are not complex.

22. The disadvantages are:

- a. A very large rotating structure is required above the relatively small immersed paddles.
- b. Water flow in only one direction is required.

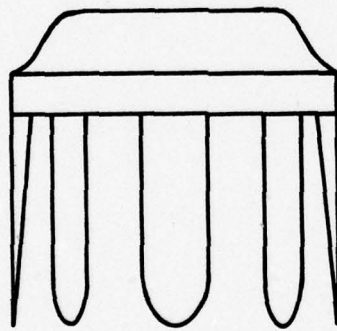
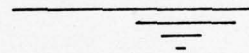
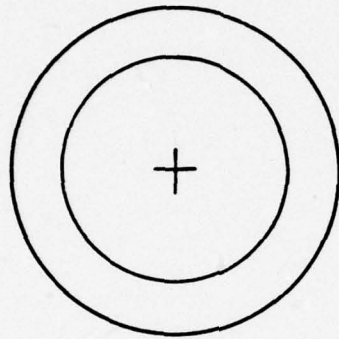

Figure C1. Vertical axis turbine based on work by Sheets¹⁷

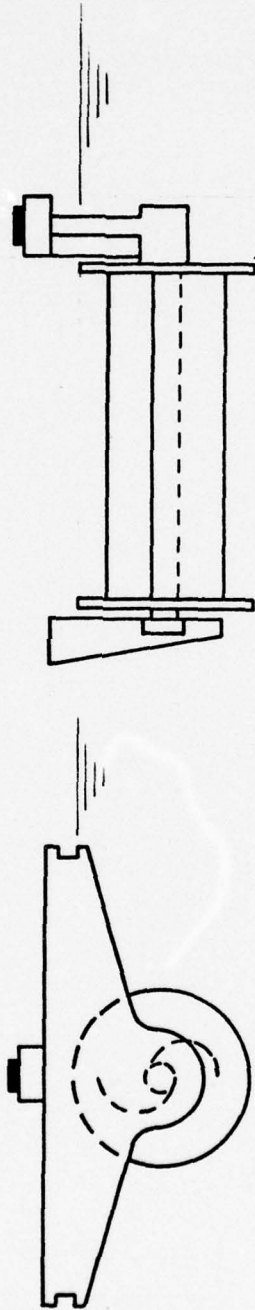

Figure C2. Savonius rotor based on work by Heronemus et al.²³

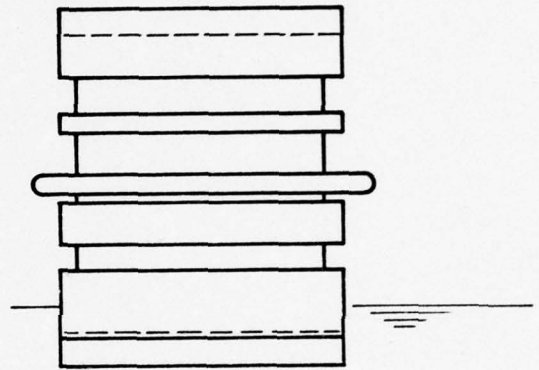
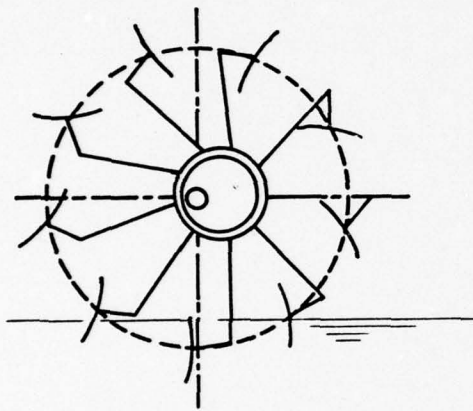

Figure C3. Water wheel based on work by Sheets¹⁷

APPENDIX D: DATA AND POWER POTENTIAL FOR SELECTED LOCATIONS

Wind Power Potential

Parametric plots

1. The performance curves for Elektro wind machines are shown in Figure D1. Based on the performance curve data, the power coefficients C_p , as functions of windspeed V , were obtained for all the Elektro units and are given in Table D1 for later use. The detailed data on the performance of the Aeromotor pumping unit are not available.

Windspeed and power duration curves

2. The windspeed V as a function of time t is not readily available from the existing data. As discussed in Appendix A, the wind data documented as a frequency of windspeed show the percentage of time (a year or a month) the windspeed was between certain values. The available data must, therefore, be reduced to the speed duration plot as follows.

- a. Starting with the zero windspeed, determine the percentage of time the windspeed is above a certain predetermined value. For instance, for 100% of the time, windspeed is above zero; this gives one point on the speed-time chart.
- b. Next, determine from the wind data the percentage of time speed is above a given value and plot it on the chart. A smooth curve through the points renders the speed-duration curve for a location. The windspeed-duration curves, each with a duration of 1 year for each site, were drawn using the annual average data.
- c. Next, the wind-power duration curve is derived from the speed duration simply by cubing the ordinate (i.e., the windspeed V) and multiplying it by the factor $(1/2)\rho A$ to obtain the power available in a column of air flowing through given disk area A .

The power duration curves, each with a duration of 1 year for each site, were prepared for later use. Both the windspeed and the power duration curves for each of the nine selected sites are shown in Figures 3 through 11. For simplicity, the disk area for the calculations was taken to be 100 sq ft; thus, the ordinate of the power duration curves in the above figures is the available power per 100 sq ft of the disk area. Also

prepared for comparison was the total available energy per 100 sq ft of the disk area at each site for a duration of 1 year, or 8760 hours; the results are shown in Table D2, which also gives the annual average windspeed at each site. Based upon the results of Table D2, Buffalo, Galveston, and Seattle show an excellent potential for windpower conversion. Norfolk, Detroit, Mobile, and Philadelphia have an average potential for wind energy, but Portland (Oregon) and Savannah (Georgia) show a relatively poor promise of wind energy. In summary, it can be stated that the windspeed duration and, hence, the corresponding power duration curves are useful tools in readily assessing the wind potential of a given site by simple calculations.

Solar Radiation Potential

Use of solar data

3. The term "solar radiation," is synonymous with the commonly accepted term of solar insolation and refers to the amount of sun energy received at the earth's surface as terrestrial solar energy.

4. Most solar radiation is measured with a horizontally positioned instrument called the pyranometer, which measures both the direct and diffuse components of the sun's energy. These data are recorded on a daily (and in some cases, hourly) basis in units of the langley (ly).*

5. Data on the average daily terrestrial solar energy received on a horizontal surface are of limited direct use in many solar energy conversion applications. What is sometimes more importantly desired are: (a) hourly solar radiation data — for hourly evaluation of particulars (system efficiency determination) of a solar energy conversion process; and (b) inclined receiving surface solar radiation data — for selection of optimum inclination or determination of energy received on a constrained receiving surface. Figures D2 and D3 show the typical daily distribution of solar radiation on clear days in the months of

* A langley is equivalent to a gram calorie per square centimetre, or, in more common notation, equal to 3.687 Btu/ft².

January and June, respectively; Figure D4 depicts the typical yearly distribution of solar radiation for various receiving surface inclinations. The following discussion allows for estimating the hourly and inclined receiving surface solar radiation data from existing data.

6. Solar time. The hourly time values referenced herein refer to solar time, which basically accounts for the orbital factors of our earth and may vary from local standard time. The adjustment for converting solar to standard times is made by the following relationship:

$$\text{Solar Time} = \text{standard time} + \text{TA} + 4(\text{Meridian} - \text{Longitude})$$

where Standard Time = local clock time at location of interest
(adjust for daylight savings time, if applicable)

TA = time adjustment, min (see Figure D5)
Meridian = standard meridian of time zone, deg West
(see Figure D6)
Longitude = longitude at location of interest, deg West

7. Length of day. The length of day (sunrise to sunset) varies throughout the year and with geographical latitude.

8. Hourly solar radiation. The amount of solar radiation received on a horizontal receiving surface and available during various hours of the day is a percentage of the total daily solar radiation for various lengths of day. This information is most useful for locations where day-long clear sky conditions prevail; for overcast sky, these data are less valid.

9. Inclined receiving surfaces. Many methods have been proposed for estimating the amount of solar radiation, on inclined south-facing surfaces, from various known parameters. The method employed herein basically follows a rationale set forth in Reference 31. The conversion of "horizontal" solar radiation data to "inclined" solar radiation is made by the following relationship:

$$SR_i = (SE_h)(RA)$$

where SR_i = Average daily solar radiation received on a south-facing surface (angle from horizontal) in ly/day

SE_h = Average daily solar radiation received on a horizontal surface, ly/day

SE_o = Average daily extraterrestrial solar radiation received on a horizontal surface, ly/day

RA = SR_i/SE_h ratio at given latitude, month, receiving surface inclination, and SE_h/SE_o ratio.

Data will be found in Reference 32. An example follows.

EXAMPLE

Location: San Antonio, Texas

Latitude: 29.5° N

Longitude: 98.5° W

- Q. What is the average daily amount of solar energy received on a horizontal surface in the months of February and September?
- A. February = 347 ly/day (1278 BTU/ft²-day)
September = 493 ly/day (1818 BTU/ft²-day)
- Q. What is the solar time at 1:00 p.m. standard time on September 15?
- A. Standard Time = 1:00; TA = 5 minutes (see Figure D5);
Meridian = 90 degrees (see Figure D6); Longitude = 98.5 degrees
(see input data)
Solar Time = 1:00 + 5 min + 4(90-98.5) = 1:05 - 34 min = 12:31 p.m.
- Q. Assuming clear-sky conditions, how much solar radiation falls on a horizontal surface between 1:00 and 2:00 p.m. in September?
- A. Length of day is approximately 12.2 hours
Solar Radiation = 12.4% of total daily input of 493 ly/day
- Q. How much daily solar radiation falls on a 30-deg south-facing surface during the month of September?
- A. SE_o = 786 ly/day (30 deg latitude)
 SE_h = 493 ly/day

$$SE_h/SE_o = 493/786 = 0.63$$

$$RA = 1.10 \text{ (30 deg latitude, 30 deg, Sept)}$$

$$SR_i = (SE_h)(RA) = 493 \text{ ly/day (1.10)} = 542 \text{ ly/day}$$

Hydraulic Power Potential

Data

10. Table D3 furnishes the local source data for hydraulic study for nine sites.

Parametric plots

11. Figures D7 to D9 are sizing and performance parametric plots for current power systems. These plots are intended to show the variation of output power with the most frequently measured characteristics of currents.

12. Figures D7 to D9 on the unidirectional current power system show the output power of devices of this type as a function of current speed. These plots are applicable to the size proportions and efficiencies given on the figures for vertical axis turbines, Savonius rotors, and waterwheels.

13. Parametric plots of tidal current power are not included because there is no common parameter that may be portrayed as a function of output power at any site. Furthermore, the energy available in the tidal currents at eight of the nine sites is minimal, and good data near enough to the ninth are not available.

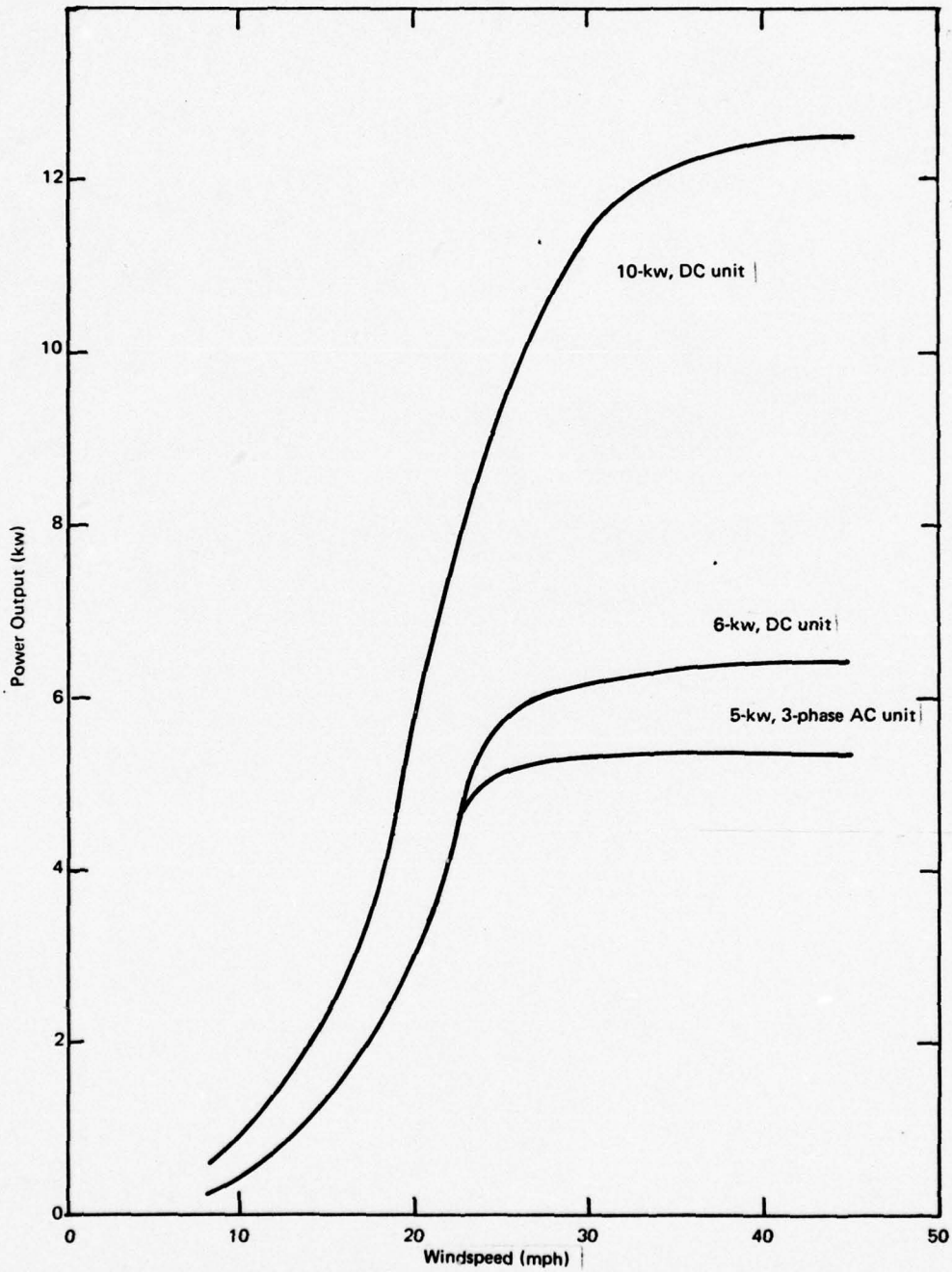

Figure D1. Power versus windspeed characteristics of Elektro wind generators

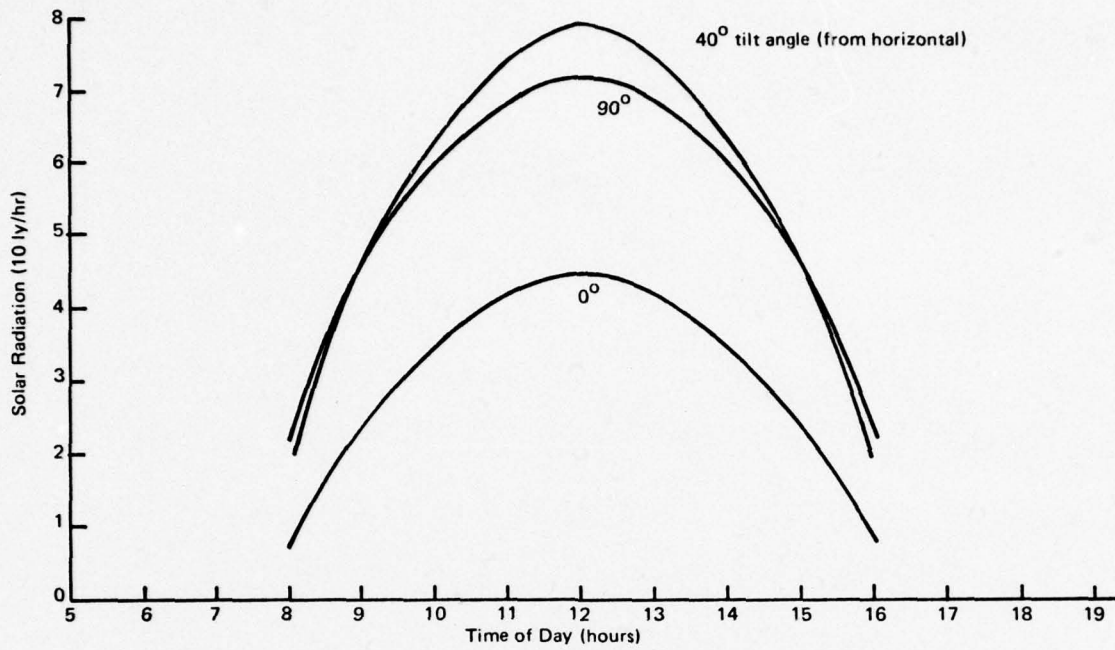

Figure D2. Average hourly solar radiation on tilted surfaces at 40°N latitude in January

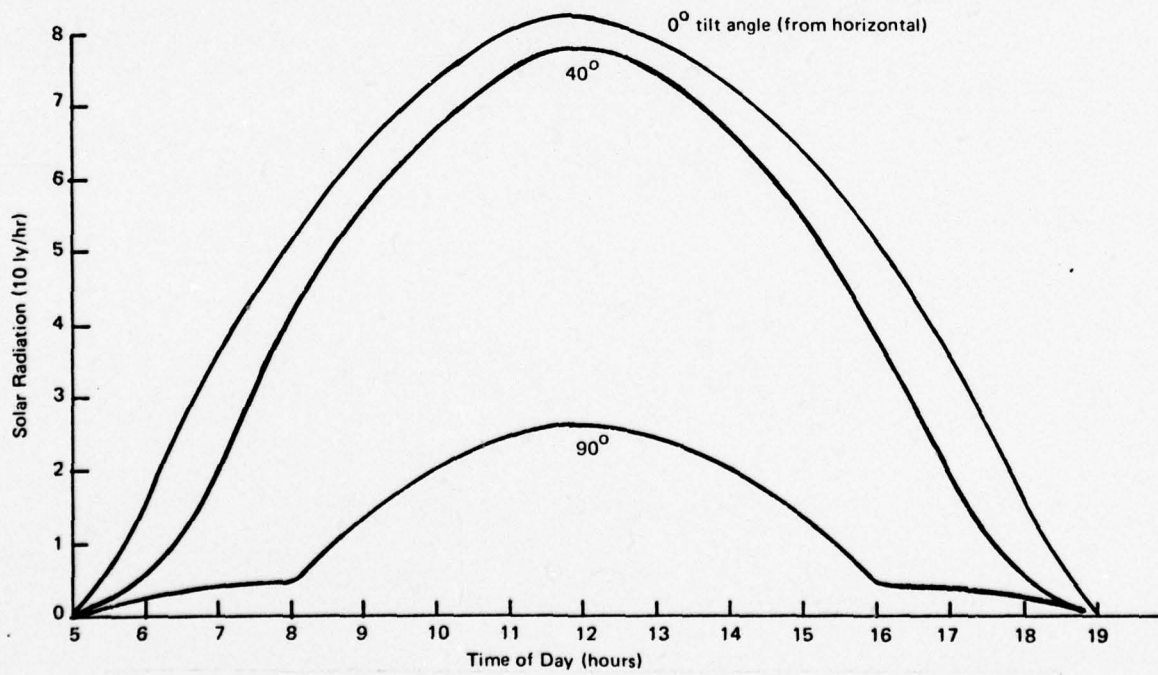

Figure D3. Average hourly solar radiation on tilted surfaces at 40°N latitude in June

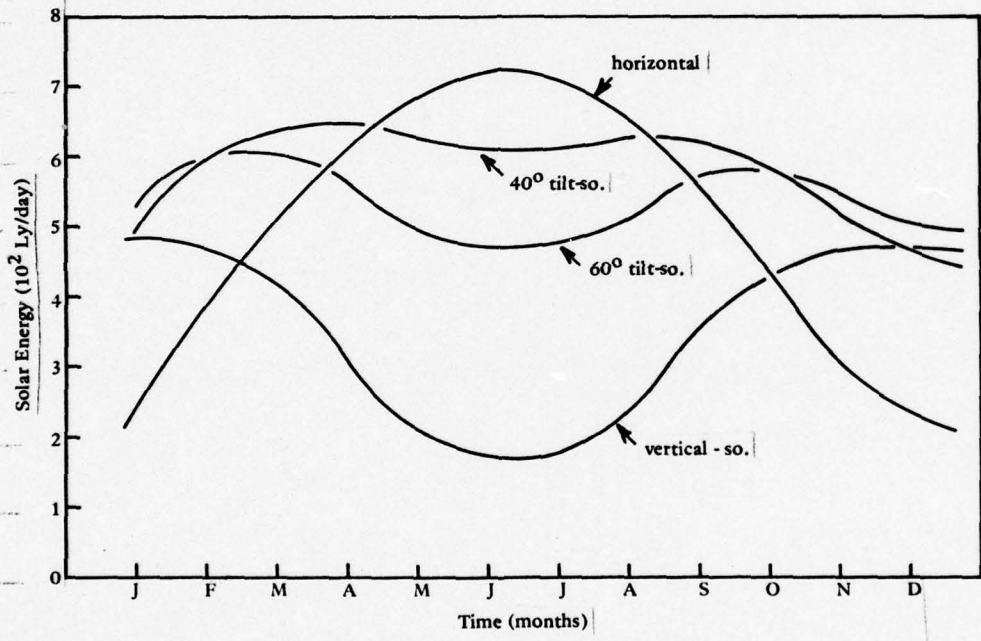

Figure D4. Energy received on tilted surfaces at 40°N latitude

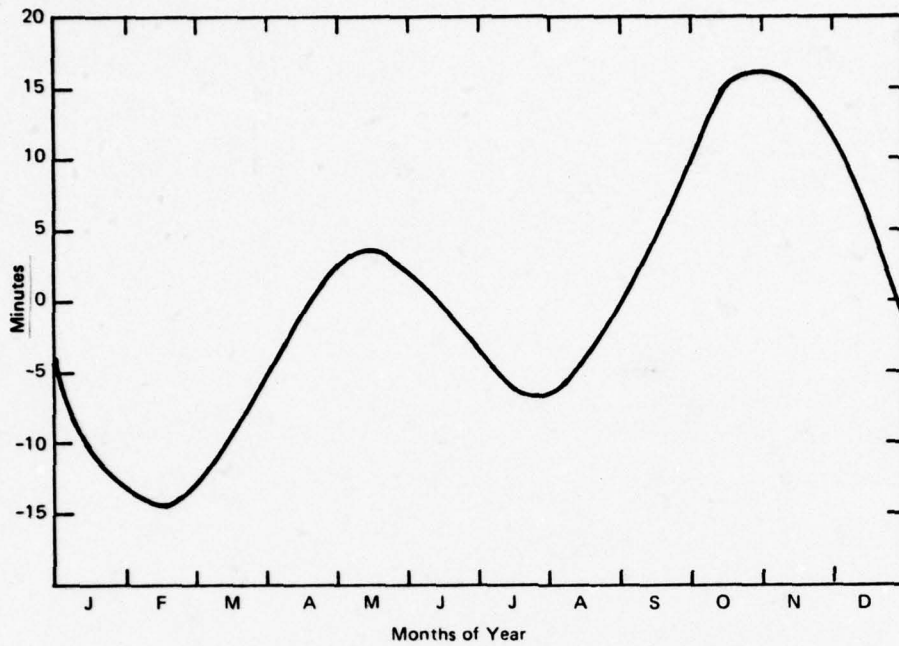

Figure D5. Graphical display of the equation of time

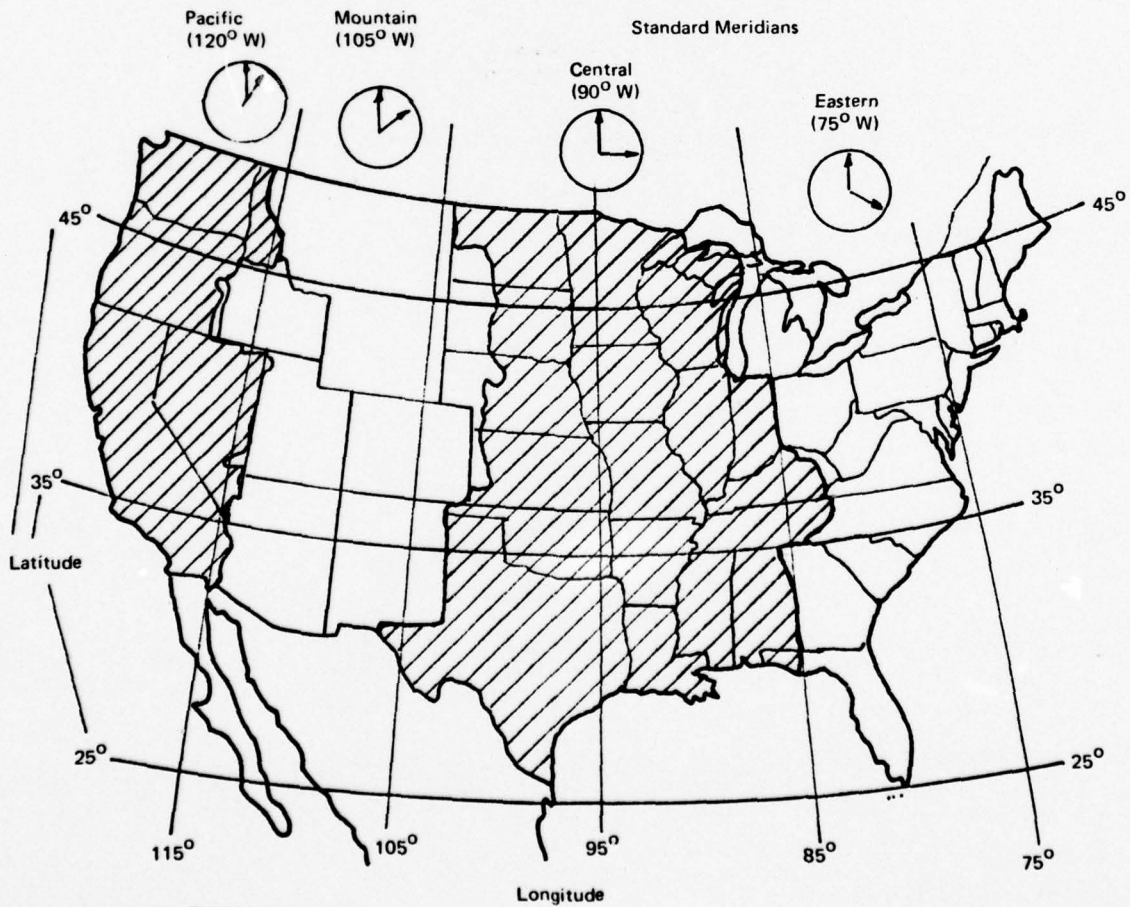

Figure D6. Latitude, longitude, and time zones of United States

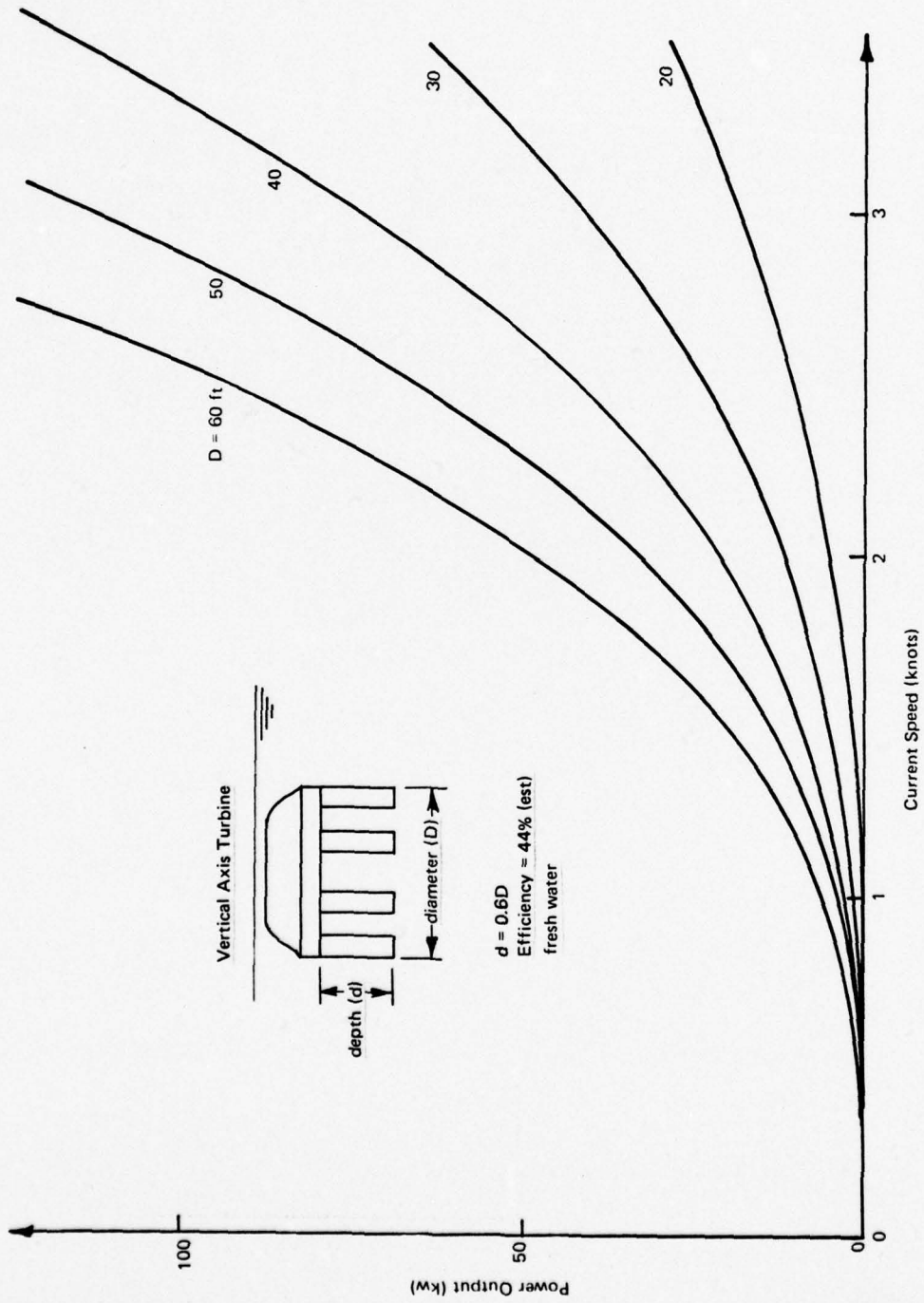

Figure D7. Unidirectional current power production - vertical axis turbine

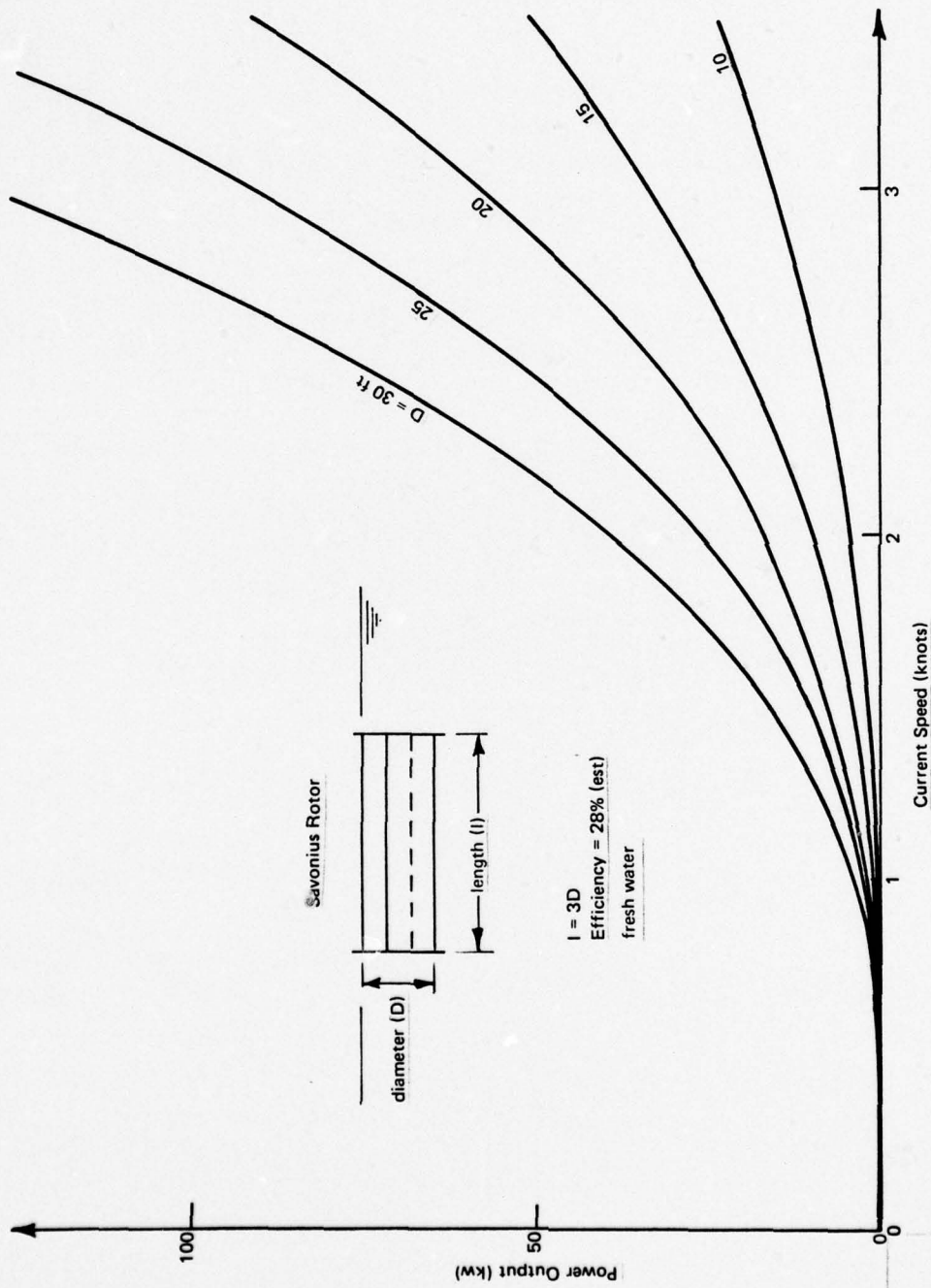

Figure D8. Unidirectional current power production - Savonius rotor

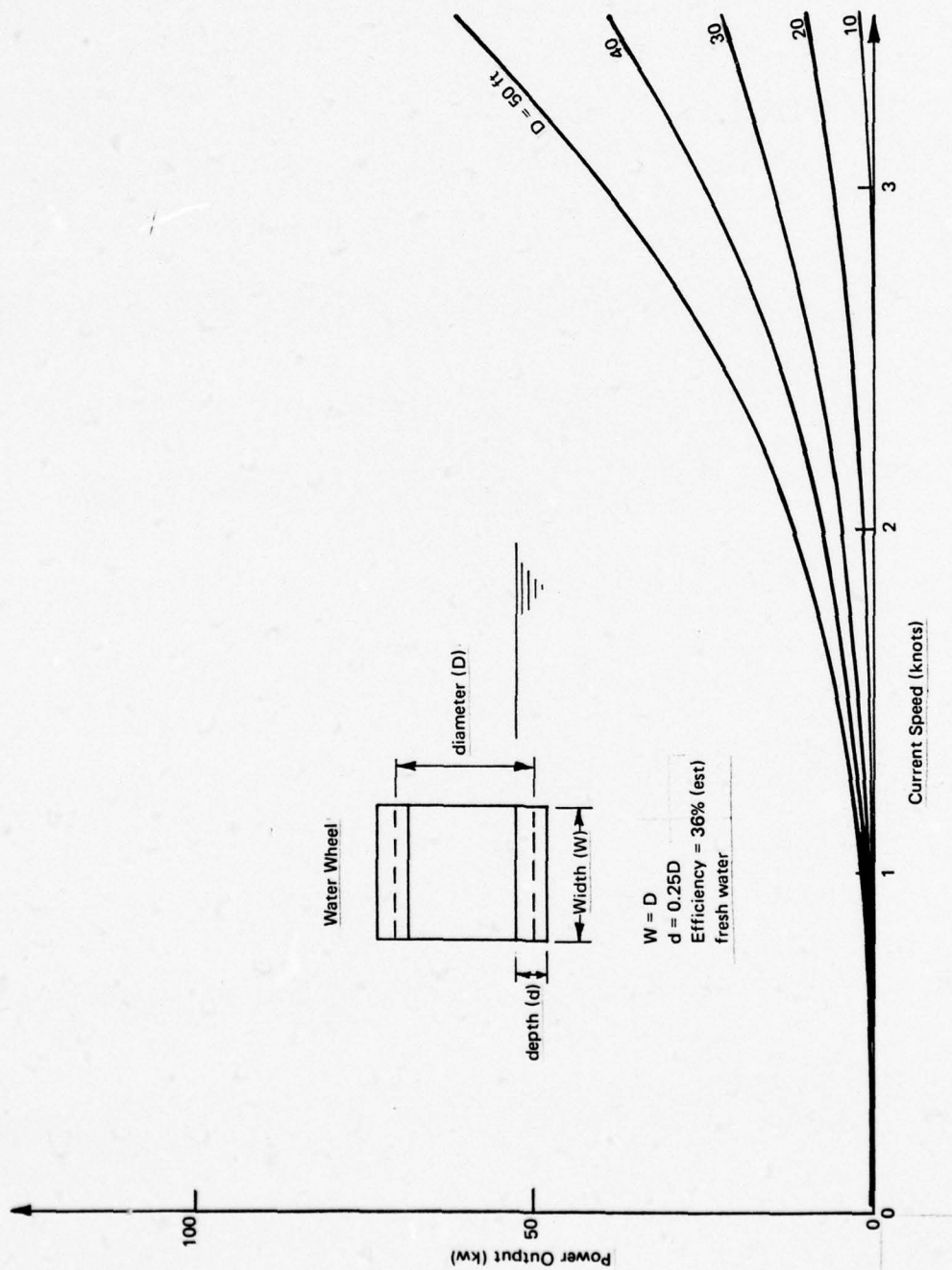

Figure D9. Unidirectional current power production - water wheel

Table D1

Power Coefficient C_p Shown as a Function of Windspeed V for
the Elektro G.m.b.h. Wind Machines

Windspeed (mph)	Power Coefficient		
	Elektro 6-kw DC	Elektro 5-kw, 3-Phase, AC Unit	Elektro 12-kw AC Unit
0	0	0	0
3	0	0	0
7	0	0	0
10	0.443	0.443	0.443
12	0.417	0.417	0.417
15	0.390	0.390	0.390
18	0.376	0.376	0.376
23	0.370	0.370	0.370
24	0.343	0.343	0.343
26	0.307	0.260	0.307
27	0.288	0.232	0.267
32	0.175	0.148	0.200
38	0.106	0.090	0.123
46	0	0	0

Table D2

Available Energy Per 100 sq ft of the Disk Area in 1 Year (8760 hours)
for the Nine Selected Sites

Location	Annual Average Windspeed (mph)	Total Available Energy Per 100 sq ft of the Disk Area in 1 Year (kw-hr/100 sq ft)
Buffalo, New York	12.4	16,634
Galveston, Texas	12.5	14,735
Seattle, Washington	10.7	11,498
Norfolk, Virginia	10.2	10,121
Detroit, Michigan	10.3	9,374
Mobile, Alabama	10.0	8,892
Philadelphia, Pennsylvania	9.6	8,481
Portland, Oregon	7.7	6,762
Savannah, Georgia	8.4	5,734

Table D3

Local Source Data for Hydraulic Study for Nine Sites

District	Site	Current			Waves		
		Data Location	Type	Speed, V (knots)	Data Location	Height, H (ft)	Period, T (s)
Philadelphia	Howell Cove Dike	Gloucester	tidal	V _{max} = 2.2 V _{min} = 2.0	not applicable	---	---
Galveston	Fort San Jacinto	Galveston Bay Entrance	tidal	V _{max} = 2.3 V _{min} = 1.7	offshore in gulf	H _{ave} = 1 to 5	T _{ave} = 1 to 5
Savannah	Andrews Island, Brunswick	Brunswick Riv off Quarantine Dock (2 miles downstream)	tidal	V _{max} = 2.1 V _{min} = 1.3	protected	---	---
Mobile	Blakely Island	Mobile River Entrance	tidal	V _{max} = 0.7 V _{min} = 0.3	protected	---	---
Seattle	Anacortes Harbor	Guemes Channel, West Entrance	tidal	V _{max} = 2.1 V _{min} = 0.9	protected	---	---
Portland	Price Island, Astoria	Glatsop Spit (22 miles downstream)	tidal	V _{max} = 4.2 V _{min} = 3.6	not applicable	---	---
Detroit	Diked Disposal Area, Toledo OH	Cherry Street Bridge (5 miles upstream)	wind dependent	V _{max} = 2.7 V _{min} = 0	Toledo	H _{ave} = 1 H _{max} = 8	T _{max} = 5 to 6

Table D3 (concluded)

District	Site	Current			Waves		
		Data Location	Type	Speed, V (knots)	Data Location	Height, H (ft)	Period, T (s)
Norfolk	Craney Island	Craney Island	tidal	V _{max} = 1.2 V _{min} = 0.7	protected	---	---
Buffalo	Cayuga Island	Niagara River (East of Grand Island)	Unidirectional	V _{ave} = 1.5	minimal	---	---

APPENDIX E: INFORMATION SOURCES

Wind Power

Bibliography

Arnas, O. A., "Wind Power Generation and Storage," Proceedings 2nd Annual U.S. National Conference on Wind Engineering Research, Fort Collins, Colorado, 22 Apr 1975.

Back, G., "Investigations Concerning Savonius Rotors and Related Turbomachines," Forschung aus dem Gebiet des Ingenieurwesens, Vol. 2, No. 6, pp. 218-231, Jun 1931, translated from German into English by G. T. Ward, Jun 1964.

Banas, J. F., Kadlec, E. G., and Sullivan, W. N., "Application of the Darrieus Vertical-Axis Wind Turbine to Synchronous Electrical Power Generation," SAND75-0165, Sandia Laboratories, Albuquerque, New Mexico, Mar 1975, p 14.

Banas, J. F., Kadlec, E. G., and Sullivan, W. N., "Methods for Performance Evaluation of Synchronous Power Systems Utilizing the Darrieus Vertical-Axis Wind Turbine," SAND75-0204, Sandia Laboratories, Albuquerque, New Mexico, Apr 1975, 22 pp.

Barasoain, J. A. and Fonta'n, L. P., "Prospecting for Wind Power with a View to its Utilization," Proceedings of the UN Conference on New Sources of Energy, Vol. 7, Wind Power, Rome, Aug 1961, pp 61-74.

Barton, T. H. and Repole, K., "A Simple Electric Transmission System for a Free Running Windmill," Technical Report No. T. 68, Aug 1970, Brace Research Institute of McGill University, Quebec, Canada.

Base, T. E., Davenport, A. G., and Baynes, C. J., "Meteorological Aspects in the Selection of Sites and the Prediction of the Performance and Fluctuating Air Loads on Airscrew Windmills," Proceedings 2nd Annual U.S. National Conference on Wind Engineering Research, Fort Collins, Colorado, 22 Apr 1975.

Blackwell, B. F. "The Vertical-Axis Wind Turbine - How it Works," SLA-74-0160, Sandia Laboratories, Albuquerque, New Mexico, Apr 1975, 9 pp.

Blackwell, B. F. and Feltz, L. V., "Wind Energy - A Revitalized Pursuit," SAND75-0166, Sandia Laboratories, Albuquerque, New Mexico, Mar 1975, 16 pp.

Blackwell, B. F. and Reis, G. E., "Blade Shape for a Troposkien Type of Vertical-Axis Wind Turbine," SLA-74-0154, Sandia Laboratories, Albuquerque, New Mexico, Apr 1974, 24 pp.

Blackwell, B. F. and Reis, G. E., "Some Geometrical Aspects of Troposkiens as Applied to Vertical-Axis Wind Turbines," SAND74-0177, Sandia Laboratories, Albuquerque, New Mexico, Mar 1975, 47 pp.

- Bodek, A., How to Construct a Cheap Wind Machine for Pumping Water, 12 p., Feb 1965. Revised Feb 1973.
- Bodek, A., "Performance Test of an 8-Meter Diameter Andreau Windmill," Report T.12, Brace Research Institute, Feb 1964.
- Chilcott, R. E., "Implications of the Utilization of Wind Power for the Development of Small Caribbean Communities," Proceedings of the Conference on Technology and Development in Small Transitional Societies, Trinidad, W. Indies, Feb 1968, 12 pp.
- Chilcott, R. E., "Implications of the Utilization of Wind Power for the Development of Small Caribbean Communities," Publication No. R25, Brace Research Institute, McGill University MacDonald College, Province of Quebec, Canada, Nov 1971.
- Chilcott, R. E., "Notes on the Development of the Brace Airscrew Windmill as a Prime Mover," Aeronautical Journal of the Royal Aeronautical Society Apr 1969, pp 333-334.
- Chilcott, R. E., "Putting the Wind to Work," Engineering, 22 Nov 1968, pp 760-761.
- Chilcott, R. E., "The Design Development and Testing of a Low Cost 10 hp Windmill Prime Mover," M.Sc. Thesis, Dept. of Agricultural Engineering, McGill University, Quebec, Canada, Jul 1969, 126 pp.
- Chilcott, R. E. and Ward, G. T., "The Potential for Medium-Power Fixed-Pitch, Variable-Speed, Airscrew Wind Machines in Canadian Agriculture," presented to the Agricultural Institute of Canada, Canadian Society of Agricultural Engineers, Hamilton, Ontario, Jun 1968.
- Clausazier, G., "Various Relationships Between Wind Speed and Power Output of a Wind Power Plant," Proceedings of the UN Conference on New Sources of Energy, Vol. 7, Wind Power, Rome, Aug 1961, pp 278-84.
- Coleman, C. C. and McKee, R. B., "A High Efficiency Propeller Type Windmill," Proceedings 2nd Annual U.S. National Conference on Wind Engineering Research, Fort Collins, Colorado, 22 Apr 1975.
- Coonley, D. R., "The Use of Natural and Man-Made Forms to Enhance the Output of Wind Collectors and to Build in Harmony with the Wind," Proceedings 2nd Annual U.S. National Conference on Wind Engineering Research, Fort Collins, Colorado, 22 Apr 1975.
- Decennial Census of the United States Climate "Summary of Hourly Observations, 1951 to 60, on Surface Winds," Climatography of the United States, Series 82, available from Environmental Data Service, National Weather Center, Ashville, North Carolina.
- Easter, B. H., "An Energy Storage System," Simulation, Sep 1969, pp 155-164.
- "Electrical Power from the Wind," Solar Wind Company, R.F.D. 2, East Holden, Maine 04429.

Emslie, K., "Industrial Uses of Wind Tunnels with Particular Reference to Wind Machines," North Atlantic Treaty Organization, Advisory Group for Aeronautics and Development, Report 306, presented at AGARD Fluid Dynamics Panel held Oct 1960, Istanbul, Turkey.

Fales, E. N., "A New Propeller-Type, High-Speed Windmill for Electric Generation," Transactions, American Society of Mechanical Engineers, New York, New York, Vol. 19, Paper AER-50-6, 1928.

"Federal Wind Energy Program Summary," Energy Research and Development Administration, Washington DC, 1 May 1975.

Feltz, L. V., and Blackwell, B. F., "An Investigation of Rotation-Induced Stresses of Straight and of Curved Vertical-Axis Wind Turbine Blades," SAND74-0379, Sandia Laboratories, Albuquerque, New Mexico, Mar 1975, 21 pp.

Galanis, N., Narasiah, S., and Dang, C. C., "Use of Wind Energy for the Aeration of Waste Waters: A Case Study," Proceedings 2nd Annual U.S. National Conference on Wind Engineering Research, Fort Collins, Colorado, 22 Apr 1975.

Gimpel, G., "The Windmill Today," Engineering, Vol. 183, 30 May 1958, p 686.

Golding, E. W., "Studies of Wind Behavior and Investigation of Suitable Sites for Wind-Driven Plants," Proceedings of the United Nations Conference on New Sources of Energy, Vol. 7, Wind Power, Rome, Italy, 21-31 August 1961, pp 3-8.

Golding, E. W. and Stodard, A. H., "The Potentialities of Wind Power for Electricity Generation (With Special Reference to Small-Scale Operation)," Technical Report Ref. No. W/T16, The British and Electrical and Allied Industries Research Association, Thorncroft Manor, Dorking Road, Leatherhead, Surrey, 1949.

Golding, E. W. and Stodard, A. H., "The Selection and Characteristics of Wind-Power Sites," Technical Report C/T108, The British Electrical and Allied Industries Research Association, Thorncroft Manor, Dorking Road, Leatherhead, Surrey, 1952.

Havinga, A., "Classical Designs of Small Drainage Windmills in Holland, with Considerations on the Possibilities of Their Improvement and Adaptation in Less Developed Countries," Proceedings of the United Nations Conference on New Sources of Energy, Vol. 7, Wind Power, Rome, Italy, 21-31 August 1961, pp 212-15.

Hutter, U., "Practical Experience Gained From the Development of a 100 kw Wind Power Installation," Brennstoff-Warmekraft, Vol. 16, No. 7, pp 333-341, Jul 1964, Translated from German into English by G. T. Ward, May 1966.

Ionson, J. M., "The Field Performance of a Windmill Powered Sprinkler Irrigation System" M. ScC. Thesis, Department of Agricultural Engineering McGill University, Quebec, Canada, Jul 1969, 96 pp.

Justus, C. G., "Nationwide Assessment of Potential Power Output from Aerogenerators," Proceedings 2nd Annual U.S. National Conference on Wind Engineering Research, Fort Collins, Colorado, 22 Apr 1975.

Kadivar, M. F., "Potential for Wind Power Development," M. Sc. Thesis, Dept. of Agricultural Engineering, McGill University, Quebec, Canada, Jul 1970, 171 pp.

Kagin, S., "Information Through Personal Communications," Real Gas and Electric Company, PO Box "A", Guerneville, California, 1975.

Kloeffler, R. G. and Sitz, E. L., "Electric Energy from the Wind," Kansas State College Bulletin, Vol. XXX, No. 9, 1 Sep 1946.

Kolmogoroff, A. N., "The Local Structure of Turbulence in Incompressible Viscous Fluid for Very Large Reynolds Numbers," C. R. Academic Sci URSS 30, 1941, pp 301-305.

Lawand, T. A., "The Economics of Wind Powered Desalination Systems," Report T.36, Brace Research Institute, Quebec, Canada, Jun 1967, 56 pp, revised Sep 1967.

Levine, C., "Windmills of Eastern Long Island," Early American Life, Vol. 5, No. 1, Feb 1974, pp 25-27, 76-77.

Levy, I. N., edited by Ward, G. T., "Current State of Wind Power Research in the Soviet Union," Technical Report No. T56, Brace Research Institute of McGill University, Quebec, Canada, Sep 1968.

Lines, W., "Percy Thomas Wind Generator Designs," Proceedings Wind Energy Conversion Systems Workshop, NSF/RA/W-73-006, National Science Foundation, Dec 1973, pp 11-16.

McCullom, K. A., "Use of Energy Storage with Unconventional Energy Sources to Aid Developing Countries," Proceedings 3rd Intersociety Energy Conversion Conference, Oklahoma State University, Stillwater, OK, 1968.

Mercadier, Y. and Camarero, R., "A Design Method for Optimum Aerogenerator Systems," Proceedings 2nd Annual U.S. National Conference on Wind Engineering Research, Fort Collins, Colorado, 22 Apr 1975.

Meroney, R. N., "Sites for Wind-Power Installations," Proceedings 2nd Annual U.S. National Conference on Wind Engineering Research, Fort Collins, Colorado, 22 Apr 1975.

Minardi, J. E. and Lawson, M., "Electrofluid Dynamic (EFD) Wind Generator," Proceedings 2nd Annual U.S. National Conference on Wind Engineering Research, Fort Collins, Colorado, 22 Apr 1975.

- Minardi, J. E. and Whitford, D. H., "The Madaras Rotating Cylinder Concept for Electric Power Generation," Proceedings 2nd Annual U.S. National Conference on Wind Engineering Research, Fort Collins, Colorado, 22 Apr 1975.
- Munn, R. E., "Descriptive Micrometeorology," Academic Press, New York, 1966, pp 66-80.
- Nakra, H., "A Report on Preliminary Testing of a Lubing Windmill Generator," MO22-3G 024-400, Brace Research Institute, Quebec, Canada, 5 pp.
- Nassar, E. M., "Model Study of the Reciprocating Wind Machine," Proceedings 2nd Annual U.S. National Conference on Wind Engineering Research, Fort Collins, Colorado, 22 Apr 1975.
- Niemi, E. E., "Transient Response of Wind Power Generators to Wind Gusts," Proceedings 2nd Annual U.S. National Conference on Wind Engineering Research, Fort Collins, Colorado, 22 Apr 1975.
- Noll, J. M., "French Wind Generator Systems," Proceedings Wind Energy Conversion Systems Workshop, NSF/RA/W-73-006, National Science Foundation, Dec 1975, pp 186-196.
- Puthoff, R. L. and Sirocky, P. J., "Preliminary Design of a 100 kw Wind Turbine Generator," International Solar Energy Society, Fort Collins, Colorado, 21-23 Aug 1974.
- "Putting the Wind to Work," Brace Research Institute, Engineering, Vol. 26, No. 5353, 22 Nov 1968, pp 760-761.
- Ramakumar, R., et al., "A Wind Energy Storage and Conversion System for Use in Under-Developed Countries," Proceedings of 4th Intersociety Energy Conversion Engineering Conference, Washington, D.C., 22-26 Sep 1969, Paper 699074, pp 606-613.
- Reed, J. W., "Wind Power Climatology of the United States," SAND74-0348, Sandia Laboratories, Albuquerque, New Mexico, May 1975, 200 pp.
- Reed, J. W. and Blackwell, B. F., "Some Climatological Estimates of Wind Power Availability," Proceedings 2nd Annual U.S. National Conference on Wind Engineering Research, Fort Collins, Colorado, 22 Apr 1975.
- Reed, J. W., Maydew, R. C., and Blackwell, B. F., "Wind Energy Potential in New Mexico," SAND74-0071, Sandia Laboratories, Albuquerque, New Mexico, Jul 1974, 42 pp.
- Reis, G. E. and Blackwell, B. F., "Practical Approximations to a Troposkien by Straight-Line and Circular-Arc Segments," SAND74-0100, Sandia Laboratories, Albuquerque, New Mexico, Mar 1975, 35 pp.
- Rosenbrock, H. H., "An Extension of the Momentum Theory of Wind Turbines," Aircraft Engineering, Vol. 23, Aug 1952, pp 226-227.
- Savino, J. M., "A Brief Summary of the Attempts to Develop Large Wind-Electric Generating Systems in the U.S.," Wind Energy Conference, Stockholm, Sweden, 29-30 Aug 1974.

- Savonius, S. J., "The S-Rotor and Its Applications," Mechanical Engineering, Vol. 53, No. 5, May 1931, pp 333-338.
- Seath, D. D., "Testing a Wind Generator Rotor," Proceedings 2nd Annual U.S. National Conference on Wind Engineering Research, Fort Collins, Colorado, 22 Apr 1975.
- Sectorov, V. R., "The Balaklavsking Experimental Electric Wind Station," Elektrichestro, No. 19, 1933.
- Shuster, D. B., Dugan, V. L., and Richard, R. H., "A Wind-Powered Fresh Water Condensation Air Conditioning, Mariculture, and Agriculture Integrated System for Pacific Atolls," SLA-74-0298, Sandia Laboratories, Albuquerque, New Mexico, Jun 1974, 11 pp.
- Slade, D. H., "Wind Measurement on a Tall Tower in Rough Terrain," Journal of Applied Meteorology, Vol. 8, Apr 1969, pp 292-297.
- Smith, B. E., "Smith-Putnam Wind Turbine Experiment," Proceedings Wind Energy Conversion Systems Workshop, NSF/RA/W-73-006, National Science Foundation, Dec 1973, pp 5-7.
- Stam, H., "Adaptation of Windmill Designs, With Special Regard to the Needs of the Less Industrial Areas," Proceedings of the United Nations Conference on New Sources of Energy, Vol. 7, Wind Power, Rome, Italy, 21-31 Aug 1961, pp 347-56.
- Strickland, J. H., Ford, S. R., and Reddy, G. B., "The Darrius Turbine: A Summary Report," Proceedings 2nd Annual U.S. National Conference on Wind Engineering Research, Fort Collins, Colorado, 22 Apr 1975.
- Swanson, R. K., Johnson, C. C., and Smith, R. T., "Wind Power Development in the United States," Southwest Research Institute, San Antonio, Texas, 15 Feb 1975.
- Szeco, G. C., "The U.S. Energy Problem," National Information Service, U.S. Dept. of Commerce, No. PB-207517, Vols. I and II, Inter-Technology Corp. ITC Report C656 to National Science Foundation, Nov 1961.
- Tennekes, H. and Lumeley, J. L., "A First Course in Turbulence," MIT Press, Cambridge, Massachusetts, 1972, p 251.
- Thomas, Percy, H., "Fitting Wind Power to the Utility Network," Report 099558, Federal Power Commission, Washington, DC, Feb 1954.
- Thomas, R. L., and Savino, J. M., "Status of Wind-Energy Conversion," NASA TM X-71523, RANN Symposium, Washington, D.C., Nov 1973.
- Thomas, R. N., "In-Situ Determination of Wind Energy," Proceedings 2nd Annual U.S. National Conference on Wind Engineering Research, Fort Collins, Colorado, 22 Apr 1975.
- Vargo, D., "Wind Energy Developments in the 20th Century," Fourth Annual Regulatory Information Systems Conference, St. Louis, Missouri, Sep 1974.

Veneruso, A. F., "An Electrical System for Extracting Maximum Power from the Wind," SAND74-0105, Sandia Laboratories, Albuquerque, New Mexico, Dec 1971, 28 pp.

Venters, J., "The Orkney Windmill and Wind Power in Scotland," Engineer, Vol. 189, Jan 1950.

Walker, J. G., "A Method for Improving the Energy Utilization of Wind-Driven Generators and Their Operation With Conventional Power Sets," Proceedings of the United Nations Conference on New Sources of Energy, Vol. 7, Wind Power, Rome, Italy, 21-31 Aug 1961, pp 363-69.

Walker, J. G., "Utilization of Random Power with Particular Reference to Small-Scale Wind Power Plots," Proceedings of the United Nations Conference on New Sources of Energy, Vol. 7, Wind Power, Rome, Italy, 21-31 Aug 1961, pp 370-375.

Weingarten, L. I. and Nickell, R. E., "Nonlinear Stress Analysis of Vertical-Axis Wind Turbine Blades," SAND74-0378, Sandia Laboratories, Albuquerque, New Mexico, Apr 1975, 21 pp.

Wilcox, C., "Motion Picture History of the Erection and Operation of the Smith-Putnam Wind Generator," Proceedings Wind Energy Conversion Systems Workshop, NSF/RA/W-73-006, National Science Foundation, Dec 1973, pp 8-10.

Wilson, A., "Comments on Brace Research Institute Windmill," Ministry of Overseas Development, Bridgetown, Barbados, Feb 1968, 2 pp.

"Wind Energy Bibliography," Windworks, Makwonago, Wisconsin, Oct 1973.

"Wind Energy Utilization Bibliography," TAC-W-75-700, Energy Information Office, Technology Applications Center, University of New Mexico, Albuquerque, New Mexico.

"Wind-Generated Electricity, Prototype 100 KW Plant," Engineering, Vol. 179, No. 4652, 25 Mar 1955.

"Windmills: The Resurrection of an Ancient Energy Technology," Science, Vol. 184, No. 4141, Jun 1974, pp 1055-1058.

Zubkovskii, S. L., "Frequency Spectra Pulsations of the Horizontal Components of Wind Velocity in Surface Air Layer," Bulletin Academic Science, USSR, Geophys. Ser. 10, 1962, pp 1425-1433.

Manufacturers of conversion systems

Aerowatt S.A.
32 rue Chazy
75 Paris 11^e
France

Automatic Power, Inc.
205 Hutcheson Street
Houston, TX 77003
(713) 228-5208

Braden Aeromotor Corporation
Broken Arrow, OK 74012
(918) 251-8511

Domenico Sperandio
Via Cimarose 13-21
58022 Follonica (GR)
Italy

Dyna Technology
Post Office Box 3263
Sioux City, IA 51102
(712) 252-1821

Elektro G.m.b.H.
Winterthur
St. Gallerstrasse 27
Switzerland

Ludwig Bening
2847 Barnstorf (Bez. Bremen)
Postfach 171
Western Germany

Local source data

1. Publications:

Climatic Atlas of the U.S., Environmental Data Service, National Oceanic and Atmospheric Administration, Department of Commerce, 1968, 80 pp.

Lantagne, M., and Ward, G. T., "Wind Power Study of the St. Lawrence Lowlands: A Survey of Available Wind Data," Oct 1968 (translated from French).

2. Governmental agencies:

Civil Engineering Laboratory
Code L80
Port Hueneme, CA 93043
(805) 982-4613

National Climatic Center
Environmental Data Service
Federal Building
Asheville, NC 28801
(704) 252-7865

Solar Radiation

Bibliography

Abbot, C. G., "Weather and Solar Variation," Solar Energy, Vol. 1, 1957, pp 3-5.

- "Alternate Strategies for Optimizing Energy Supply, Distribution, and Consumption Systems on Naval Bases," Booz, Allen and Hamilton, Inc., Chicago, Illinois, 1974.
- Anderson, L. B., Hottell, H. C., and Whillier, A., "Solar Heating Design Problems," Solar Energy Research No. 47, University of Wisconsin, Madison, Wisconsin, 1955.
- Bassler, F., "Solar Depression Power Plant of Qattara in Egypt," Solar Energy, Vol. 14, No. 1, Dec 1972.
- Beck, E. J. and Field, R. L., "Solar Heating of Buildings and Domestic Hot Water," Technical Report R835, Civil Engineering Laboratory, Port Hueneme, California, Jan 1976.
- Bennet, I., "Correlation of Daily Isolation With Daily Total Sky Cover, Opaque Sky Cover, and Percentage of Possible Sunshine," Solar Energy, Vol. 12, 1969, pp 391-393.
- Bliss, R. W., "The Derivation of Several Plate-Efficiency Factors Useful in the Design of Flat Plate Solar Heat Collectors," Solar Energy, Vol. 3, No. 4, 1959, pp 55-64.
- Buchberg, H. and Roulet, J. R., "Simulation and Optimization of Solar Collection and Storage for House Heating," Solar Energy, Vol. 12, 1968, pp 31-33.
- Carnes, A., "Heating Water by Solar Energy," Agricultural Engineering, Vol. 13, No. 6, 1932, pp. 156-159.
- Chung, R., Duffle, J. A., and Lof, G.O.G., "A Study of Solar Air Conditioner," Mechanical Engineer, No. 85, 1963, p 31.
- Clark, A. F. et al., "Experimental Performance of Shallow Solar Ponds," Solar Energy, Vol. 14, No. 1, Dec 1972.
- Close, D. J., "The Performance of Solar Water Heaters With Natural Circulation," Solar Energy, Vol. 16, No. 1, 1972.
- Close, D. J., "Solar Air Heaters for Low and Moderate Temperature Applications," Solar Energy, Vol. 7, No. 3, 1963, pp 117-124.
- Davis, E. S., "Solar-Assisted Gas-Energy Water-Heating Feasibility for Apartments," Jet Propulsion Laboratory, Pasadena, California, 1975.
- Deris, N., "Optimum Angle of Inclination," Air Conditioning, Heating and Ventilating, 1961.
- "Development of a Solar-Powered Residential Heating and Cooling System," NTLS Report No. M-TU-74-3, National Aeronautics and Space Administration, G. C. Marshall Space Flight Center, 1974.
- deWinter, F., "Fin Effectiveness or Efficiency in Flat Plate Solar Collectors," Copper Development Association, New York, 1973.

Dickinson, W. C., et al., "The Shallow Solar Pond Energy Conversion System," Transactions ASES Annual Meeting, 20-23 Aug 1974, Fort Collins, Colorado.

Duffie, J. A. and Beckman, W. A., "Solar Energy Thermal Processes," Wiley & Sons, New York, 1974.

Edwards, D. K., et al., "Basic Studies on the Use and Control of Solar Energy," Engineering Report No. 60-93, University of California, 1960.

Eibling, J. A., Talbert, S. G., and Lof, G.O.G., "Solar Stills for Community Use - Digest of Technology," Solar Energy, Vol. 13, No. 2, May 1971.

Farber, E. A., "Solar Energy Conversion and Utilization," Engineering Progress at the University of Florida, Vol. 23, No. 7, Gainesville, FL, 1969.

Farber, E. A. and Reed, J. C., "Practical Applications of Solar Energy," Consulting Engineer, Sep 1956.

Gary, H. P., "Effect of Dirt on Transparent Covers in Flat Plate Solar Energy Collectors," Solar Energy, Vol. 15, No. 4, 1974, pp 299-301.

Gillette, R. B., "Analysis of the Performance of a Solar Heated House," M.Sc. Thesis, University of Wisconsin, Madison, Wisconsin, 1959.

Gupta, C. L., and Garg, H. P., "System Designin Solar Water Heaters With Natural Circulation," Solar Energy, Vol. 12, 1968, pp 163-165.

"Harnessing the Sun's Energy for Heating and Cooling," Marshall Space Flight Center, Huntsville, AL, 1974.

Haywood, H., "The Computation of Solar Radiation Intensities - Solar Radiation on Inclined Surfaces," Solar Energy, Vol. 10, No. 1, 1966, pp 46-52.

Hirschmann, J. R., "Salt Flats as Solar-Heat Collectors for Industrial Purposes," Solar Energy, Vol. 13, No. 1, Apr 1970.

Hottel, H. C. and Woertz, B. B., "The Performance of Flat Plate Collectors," Transactions American Society of Mechanical Engineers, Vol. 64, Feb 1942, pp 99-103.

Kettani, M. Ali, and Gonsalves, L. M., "Heliohydroelectric (HHE) Power Generation," Solar Energy, Vol. 14, No. 1, Dec 1972.

Lee, R., "Evaluation of Solar Beam Irradiation as a Climatic Parameter of Mountain Watersheds," Colorado State University, Fort Collins, Colorado, 1963.

Lee, J. C. and Lucci, A. D., "Large-Area Solar Pond/Collectors for Hydroponic Farm Heating," Transactions ASES Annual Meeting, 20-23 Aug 1974, Fort Collins, Colorado.

- Liu, B. H. and Jordan, R. C., "Daily Insolation on Surfaces Tilted Toward the Equator," Transactions American Society of Heating Refrigerating and Air Conditioning Engineers, New York, 1961, pp 53-59.
- Liu, B. H. and Jordan, R. C., "Availability of Solar Energy for Flat-Plate Solar Heat Collectors, Low Temperature Application of Solar Energy," American Society of Heating, Refrigerating, and Air Conditioning Engineers, New York, 1967.
- Lof, G.O.G., Duffie, V. A., and Smith, C. O., "World Distribution of Solar Radiation," Report No. 21, Solar Energy Laboratory, College of Engineering, University of Wisconsin, Engineering Experiment Station, Jul 1966.
- Lof, G.O.G. and Karak, S., "A Rational Method for Evaluating Solar Power Generation Concepts," No. PB 227822, Colorado State University, Fort Collins, Colorado, 1973.
- Lof, G.O.G. and Nevens, T. O., "Heating of Air by Solar Energy," Ohio Journal of Science, Vol. 53, 1953, pp 272-280.
- Lof, G.O.G., and Tybout, R. A., "Cost of House Heating With Solar Energy," Solar Energy, Vol. 14, 1973, pp 253-255.
- Loudon, A., "The Interpretation of Solar Radiation Measurements for Building Problems," Building Research Current Papers, Garston, England, 1967.
- Lumsdaine, E., "Solar Heating of a Fluid Through a Semi-Transparent Plate: Theory and Experiment," Solar Energy, Vol. 12, No. 4, Dec 1969.
- Morse, R. N., Davey, E. T., and Welch, L. W., "High Temperature Solar Water Heating," Paper EH60, ISES International Conference, Paris, 1973.
- Morse, R. N. and Czarnecki, J. T., "Flat Plate Absorbers: The Effect on Incident Radiation of Inclination and Orientation," Report EE 6 of Engr. Sec., Commonwealth Scientific and Industrial Research Organization, Melbourne, Australia, 1958.
- Nielsen, C. and Rabl, A., "Operation of a Small Gradient Solar Pond," Solar Energy, Vol. 12, No. 4, Dec 1969.
- Norris, D. J., "Correlation of Solar Radiation With Clouds," Solar Energy, Vol. 10, No. 2, 1968, pp. 107-112.
- Norris, D., "Solar Radiation on Inclined Surfaces," Solar Energy, Vol. 10, No. 2, 1966.
- Obrecht, M. F., "Performance and Selection of Materials for Potable Hot Water Service," Heating, Piping, and Air Conditioning, Aug 1973, pp. 53-59.
- Pope, R. B. and Schimmel, W. P., "The Solar Community and the Cascaded Energy Concept Applied to a Single House and a Small Subdivision," Sandia Laboratories, Albuquerque, New Mexico, 1973.

- Rabl, A. and Nielsen, C. E., "Solar Ponds for Space Heating," Transactions ASES U.S. Annual Meeting, 20-23 Aug 1974, Colorado State University, Fort Collins, Colorado. (Also available Solar Energy, Vol. 17, No. 1, Apr 1975.)
- Ragsdale, R. G. and Namkoong, D., "The NASA Langley Building Solar Project and the Supporting Lewis Solar Technology Program," Lewis Research Laboratory, Cleveland, OH, 1974.
- Sadler, G. W., "Direct and Diffuse Insolation Using Approximation Methods Applied to Horizontal Surface Insolation," Solar Energy, Vol. 7, 1975, pp. 39-46.
- Savage, S., "Solar Ponds," Transactions Session 35, 1975 International Energy Congress and Exposition, Los Angeles, 30 Jul 1975.
- Schmidt, R. N., "Solar Energy-Thermal Conversion," University of Minnesota (NST/RANN), Minneapolis, Minnesota, 1974.
- Selcuk, K., "Thermal and Economic Analysis of the Overlapped-Glass Plate Solar-Air Heater," Solar Energy, Vol. 13, 1971, pp. 165-191.
- Smith, G., "Project Independence Blueprint - Final Report of the Solar Energy Task Force to the Federal Energy Administration," Federal Energy Administration, Washington, D.C., 1974.
- "Solar Energy Utilization for Heating and Cooling, Application," American Society of Heating, Refrigerating, and Air Conditioning Engineers Handbook of Fundamentals, Chapter 59, New York, 1974.
- "Solar Heating and Cooling of Buildings (Phase O)," Report No. W-DESC-SS-10275-4, Westinghouse Electric Corp., Baltimore, 1974.
- "Solar Radiation Sum of Day 480 Reference Manual," National Weather Records Center, ESSA, Data Processing Division, ETAC, USAF, Asheville, North Carolina, 1967.
- Speyer, E., "Optimum Storage of Heat With a Solar House," Solar Energy, Vol. 3, No. 4, 1959, pp 24-27.
- Styris, E. L., Harling, O. K., and Zaworski, R. J., Transactions Session 35, 1975 International Solar Energy Congress and Exposition, Los Angeles, 30 Jul 1975.
- Swartman, R. K. and Ogunlade, O., "Solar Radiation Estimates From Common Parameters," Solar Energy, Vol. 11, No. 3 & 4, Jul-Dec 1967.
- Tabor, H., "Mirror Boosters for Solar Collectors," Solar Energy, Vol. 10, No. 3, Jul-Sep 1966.
- Tabor, H., "Solar Collector Developments in Israel," Solar Energy, Vol. 3, No. 3, Oct 1959.
- Tabor, H., "Solar Ponds - Large Area Collectors for Power Production," Solar Energy, Vol. 7, No. 4, Oct-Dec 1963, pp 189-194.

Terjung, W. H., "A Global Classification fo Solar Radiation," Solar Energy, Vol. 13, 1970, pp 67-81.

Teweles, S., "Requirements for Solar Radiation Observations From a U.S. Network," Final Document, Conference of Solar Radiation Users, 29-30 May 1974, Silver Spring, Maryland.

Thomason, H. E. and Thomason, H. J. L., "Solar/Houses/Heating and Cooling Progress Report," Solar Energy, Vol. 15, 1974, pp 27-31.

Threlkeid, J., "Solar Irradiation of Surfaces on Clear Days," Transactions American Society of Heating, Refrigerating, and Air Conditioning Engineers, New York, 1963, pp 24-36.

Threlkeid, J. L. and Jordan, R. C., "Direct Solar Radiation Available on Clear Days," Heating, Piping, and Air Conditioning, Dec 1957, pp 135-145.

Tybout, R. A. and Lof, G.O.G., "Solar House Heating," National Resources Journal, Vol. 10, 1970, pp 268-326.

Veltford, T. E., "Solar Water Heaters," Copper & Brass Research Association, New York, Mar 1942.

Whillier, A., "Design Factors Influencing Solar Collectors - Low Temperature Engineering Applications of Solar Energy," American Society of Heating, Refrigerating, and Air Conditioning Engineers, New York, 1967.

Whillier, A., "Plastic Covers for Solar Collectors," Solar Energy, Vol. 7, No. 3, 1963, pp 148-151.

Whillier, A., "Technical Note - Solar Radiation Graphs," Solar Energy, Vol. 9, No. 3, 1965, pp 164-165.

Whillier, A. and Saluja, G., "Effects of Materials and of Construction Details on the Thermal Performance of Solar Water Heaters," Solar Energy, No. 9, 1965, pp 21-26.

Wolt, M., "Solar Energy: An Endless Supply," University of Pennsylvania, Philadelphia, 1973.

Hellott, J. I., "Utilization of Sun and Sky Radiation for Heating and Cooling Buildings," American Society of Heating, Refrigerating, and Air Conditioning Engineers Journal, Dec 1973, pp 31-42.

Zarem, A. M. and Erway, D. D., Introduction to the Utilization of Solar Energy, McGraw-Hill, New York, 1963.

Zerlaut, G. A., "Insolation Measurements, Data, and Their Significance in Solar Engineering," Desert Sunshine Exposure Tests, Inc., Phoenix, Arizona, 1974.

Manufacturers

AAI Corporation
P.O. Box 6767
Baltimore, MD 21204

American Solar Energy Corp.
2960 Westwood St.
Las Vegas, NV 89102

American Sun Industries
3477 Old Conejo Road
Newbury Park, CA 91320

Beutel's Solar Heating Co.
1527 North Miami Ave.
Miami, FL 31136

D & J Sheet Metal Co.
10055 N.W. 7th Ave.
Miami, FL 33150

E & K Service Co.
16824 74th Ave., N.E.
Bothell, WA 98011

Emerson Electric Co.
8100 W. Florissant
St. Louis, MO 63136

Energy Systems, Inc.
634 Crist Dr.
El Cajon, CA 92021

Environmental Designs
Div. of Steelcraft Corp.
P.O. Box 12408
Memphis, TN 38112

Free Heat
P.O. Box 8934
Boston, MA 02114

Gaydart Industries, Inc.
8542 Edgeworth Dr.
Capital Heights, MD 20027

General Industries
2238 Moffett Dr.
Ft. Collins, CO 80521

Helio-Dynamics, Inc.
518 So. Van Ness Ave.
Los Angeles, CA 90020

Honeywell Inc.
2600 Ridgway Parkway
Minneapolis, MN 55413

Inter Technology Corporation
P.O. Box 340
Warrenton, VA 22186

ASG Industries
P.O. Box 129
Kingsport, TN 37662

CSI Solar Systems Division
12400 49th St., North
St. Petersburg, FL 33732

Daylin, Inc. (Sunsorce)
9606 Santa Monica Blvd.
Beverly Hills, CA 90210

Edwards Engineering Co.
Pompton Plains, NJ 97444

Energex Corporation
5115 Industrial Road, Suite #513
Las Vegas, NV 89118

Enthone Div.
Am. Smelting & Refining Co.
P.O. Box 1900
West Haven, CT 06510

Fred Rice Productions, Inc.
6313 Peach Ave.
Van Nuys, CA 91401

Garden Way Labs
P.O. Box 66
Charlotte, VT 05445

General Electric
King of Prussia Park
P.O. Box 8661
Philadelphia, PA 19101

Hadley Solar Energy Co.
P.O. Box 1456
Wilmington, DE 19899

Hitachi America Ltd.
437 Madison Ave.
New York, NY 10022

International Solarthermics Corp.
P.O. Box 397
Nederland, CO 80466

Itek Corp., Optical Systems Div.
10 Maguire Rd.
Lexington, MA 02117

J. and R. Simmons Construction
Co., Inc.
2185 Sherwood Dr., South
Daytona, FL 32019

Northrup, Inc.
2208 Canton St.
Dallas, TX 75201

Owens-Illinois
P.O. Box 1035
Toledo, OH 43666

Physical Industries Corp.
P.O. Box 357
Lakeside, CA 92040

PPG Industries, Inc.
One Gateway Center
Pittsburgh, PA 15222

Revere Copper and Brass, Inc.
P.O. Box 151
Rome, NY 13440

Rodgers & McDonalds
3003 N.E. 19th Dr.
Gainesville, FL 32601

Skytherm Processes & Engr.
2424 Wilshire Blvd.
Los Angeles, CA 90056

Solar Energy Development, Inc.
1437 Alameda Ave.
Lakewood, OH 44107

Solar Energy Engineering
748 Big Tree Rd., S.
Daytona, FL 32019

Solar Energy Research Corp.
10075 County Line Rd.
Longmont, CO 80501

Solar Products, Inc.
P.O. Box 52883
San Juan, Puerto Rico 00903

Solar Systems
323 Country Club Dr.
Rehoboth Beach, DE 19971

Materials Consultants, Inc.
2150 So. Josephine St.
Denver, CO 80202

Obelitz Industries Inc.
P.O. Box 2788
Seal Beach, CA 90740

People/Space Co.
259 Marlboro St.
Boston, MA 02109

Powell Brothers, Inc.
5903 Firestone Blvd.
South Gate, CA 90280

Raypack, Inc.
31111 Agoura Rd.
Westlake Village, CA 91361

Reynolds, Inc.
P.O. Box 3069
Torrance, CA 90509

Schultz Field Enterprises
La Jolla, CA 92036

Solar Conversion Corp. of America
P.O. Box 15358
Long Beach, CA 90815

Solar Energy Digest
P.O. Box 17776
San Diego, CA 92117

Solar Energy Inc.
171 Belmar Blvd.
Avon Lake, OH 44012

Solar Power Corp.
930 Clocktower Parkway
New Port Richey, FL 33552

Solar Water Heater Co.
10221 S.W. 38th Terrace
Miami, FL 33165

Solaron Corporation
4850 Olive St.
Denver, CO 80022

Solarsystems
1515 W.S.W. Loop 323
Tyler, TX 75701

Solergy
150 Green St.
San Francisco, CA 94111

Sol-Therm Corp.
7 West 14th St.
New York, NY 10011

Sunearth, Inc.
P.O. Box 99
Milford Square, PA 18935

Sunwater Co.
1112 Pioneer Way
El Cajon, CA 92020

The Stolle Corp.
1501 Michigan St.
Sidney, OH 45365

Unitspan Architectural Systems,
Inc.
9419 Mason Ave.
Chatsworth, CA 91311

W. R. Robbins & Sons
1401 N.W. 20th St.
Miami, FL 33125

Youngblood Co., Inc.
1085 N.W. 36th St.
Miami, FL 33142

Local source data

1. Publications:

Atlas, R. A. and Charles, B. N., "Summary of Solar Radiation Observation, Tabular Summaries," Report D2-90577-2, Boeing, Corp., Seattle, 1964.

Becker, C. and Boyd, J., "Solar Radiation Availability on Surfaces in the United States as Affected by Season, Orientation, Latitude, Altitude, and Cloudiness," Solar Energy, Vol. 1, No. 1, 1957.

Bennett, I., "Monthly Maps of Mean Daily Insolation for the United States," Solar Energy, Vol. 9, No. 3, 1965, pp 145-158.

Bennett, I., "Frequency of Daily Insolation in Anglo-North American During June and December," Solar Energy, Vol. 11, No. 1, 1967, pp 41-55.

"Climatological Data, National Summary," National Oceanic and Atmospheric Administration, Environmental Data Service, Washington, DC, Annual.

Solartec, Inc.
1035 Ea. Peachtree St.
Lakeland, FL 33801

Sol-R-Tech
The Trade Center
Hartford, VT 05047

Sunburst, Inc.
70 N.W. 94th St.
Miami Shores, FL 33150

Sunshine Energy Corp.
Route 25
Brookfield Center, CT 06805

Sunworks, Inc.
669 Boston Post Rd.
Guilford, CT 06437

Tranter, Inc.
735 E. Haxel St.
Lansing, MI 48909

U.S. Solar Corporation
6407 Ager Rd.
West Hyattsville, MD 20782

Ying Mfg. Corporation
1940 W. 144th St.
Gardena, CA 92049

Climatic Atlas of the United States, National Oceanic and Atmospheric Administration, Environmental Data Service, 1968, 80 pp.

Fritz, S., "Weekly Mean Values of Daily Total Solar and Sky Radiation," Technical Paper No. 11, Supplement #1, U.S. Department of Commerce, Washington, DC, 1955.

Marine Climatic Atlas of the World, Vol. 2, North Pacific Ocean, U.S. Navy, Chief of Naval Operation, Washington, DC, 1956

"Mean Daily Solar Radiation, Monthly and Annual Climatic Atlas of the United States," U.S. Department of Commerce, Asheville, NC, 1974.

Moon, P., "Proposed Standard Solar Radiation Curves for Engineering," Journal of the Franklin Institute, pp 583-618.

Visher, S. S., Climatic Atlas of the United States, Harvard U. Press, Cambridge, 1954.

2. Local data sources*

National Climatic Center, Environmental Data Service, Federal Building, Asheville, NC 28801, (704) 252-7865.

Hydraulic Power

Bibliography

Beck, E. J., "Ocean Thermal Gradient Hydraulic Power Plant," Science, Vol. 189, No. 4199, 25 Jul 1975, pp 293-294.

Becker, W. W., "An Inquiry into the Feasibility of Using Ocean Wave Energy to Power an Oceanographic Data Collection Buoy," University of Rhode Island, 1968.

* Until recently the principal source for obtaining solar radiation measurements was the National Weather Service at Asheville, N.C. These data are sparsely recorded, applicable only to horizontal receiving surfaces, and its credibility sometimes questioned because there was only limited interest in solar radiation measurements prior to the "energy crisis." Today, however, in addition to the National Climatic Center, the refinement of the Weather Service, and the expansion of its data acquisition program, there are other government agencies, numerous schools, solar energy related equipment manufacturers, utilities, and even individuals taking solar radiation measurements. It will take time for these new data sources to establish statistical recordings that can be utilized, but these new sources will eventually fill present data voids in both geographical location and receiving surface's orientation/inclination.

- Belt, J. R. and Nutt, H. V., "Proceedings of Workshop of Navy Alternate Energy Sources Research and Development," Report 4195, Jan 1974, Naval Ships Research and Development Center, Carderock, MD.
- Cohn, P. D. and Wetch, J. R., "Power Sources," Handbook of Ocean and Underwater Engineering, by Myers, J. J., Holm, C. H., and McAllister, R. F., McGraw-Hill, New York, 1969, pp 6-32-6-33.
- Colburn, W. E. and Motherway, D. L., "Coast Guard Evaluation of the Wave Activated Turbine Generator (WATC) Buoy," Proceedings Offshore Technology Conference, Houston, TX, Vol. 2, May 1975.
- Frye, R., "The Economics of Unconventional Energy Resources," Proceedings of 10th Annual Conference, Marine Technology Society, Washington, D.C., Sep 1974, pp 455-464.
- Gray, T. and Gashus, O., (ed.), Tidal Power, Plenum, New York, 1972.
- Green, J., "A Self-Contained Oceanic Resources Base," Marine Technology Society Journal, Vol. 4, No. 5, Sep-Oct 1970.
- Griffin, O. M., "Energy From the Ocean; An Appraisal," Memorandum Report NRL-MR-2803, May 1974, Naval Research Laboratory, Washington, D.C.
- Heronemus, W. E., "Alternate Energy Sources From the Ocean," Marine Technology Society Journal, Vol. 8, No. 2, Feb 1974, pp 35-38.
- Isaacs, J. D. and Castel, D., "Wave Powered Generator System" Sea Grant Annual Report R/E-6, University of California, San Diego, 1971-72.
- Kayser, H., "Energy Generation From Sea Waves," Proceedings of International Conference on Engineering in the Ocean Environment, Institute of Electrical and Electronic Engineers, Vol. 1, Halifax, Nova Scotia, Aug 1974, pp 240-243.
- Lawton, F. L., "Time and Tide," Oceanus, Vol. 17, Summer 1974, pp 30-37.
- Lebarbier, C. H., "Power From Tides - The Rance Tidal Power Station," Naval Engineers Journal, Vol. 87, No. 2, Apr 1975, pp 57-71.
- Levenspiel, O. and de Nevers, N., "The Osmatic Pump," Science, 10 Jan 1974, Vol. 183, No. 4121, pp 157-160.
- Ley, W., "Waves and Warm Water," Engineers' Dreams, Viking, New York, 1960.
- Martin, M. D., "Power From Ocean Waves," Proceedings of Winter Annual Meeting, American Society of Mechanical Engineers, New York, NY, Nov 1974, Paper 74-WA/PWR-5.
- Masuda, Y., "Study of Wave Activated Generator and Future View as Island Power Source," Proceedings of the International Ocean Development Conference, Tokyo, 1973, No. 2.
- Masuda, Y., "Wave Activated Generator," Proceedings of the International Colloquium on the Exposition of the Oceans, Bordeaux, France, Mar 1971.

- McCormick, M. E., "An Analysis of a Stationary Pneumatic Wave Energy Converter," Paper No. 74-WA/Oct 2, Winter Annual Meeting, Nov 1974, American Society of Mechanical Engineers.
- McCormick, M. E., "An Analysis of a Wave Energy Conversion Buoy," Journal of Hydronautics, American Institute of Aeronautics and Astronautics, Vol. 8, No. 3, Jul 1974, pp 77-82.
- McCormick, M. E., "A Parametric Study of a Wave-Energy Conversion Buoy," Preprints Offshore Technology Conference, Houston, Texas, May 1974, Vol. 2, pp 959-966.
- McCormick, M. E., Carson, B. H., and Rau, D. H., "An Experimental Study of a Wave Energy Conversion Buoy," Marine Technology Society Journal, Vol. 9, No. 3, Mar 1975, pp 39-42.
- Muir, W. T., "Florida Energy Demands," Proceedings, MacArthur Workshop on the Feasibility of Extracting Usable Energy From the Florida Current, Palm Beach Shores, Florida, Feb-Mar 1974.
- "New Concept for Extracting Power From the Sea," Ocean Industry, Vol. 10, No. 2, Feb 1975, pp 168-170.
- "Power From Ocean Temperature Differences?" Marine Technology Society Journal, Vol. 8, No. 7, Aug 1974, pp 9-10.
- Richards, A. F., "Extracting Energy From the Oceans: A Review," Marine Technology Society Journal, Vol. 10, No. 2, Feb-Mar 1976, p 5-24.
- Roberts, R., "Energy Sources and Conversion Techniques," American Scientist, Vol. 61, No. 1, Jan-Feb 1973, pp 66-75.
- Severn, B. and Wilson, E. M., "Economical Tidal Energy," Proceedings of Conference on Engineering in the Ocean Environment, Institute of Electrical and Electronic Engineers, Halifax, Nova Scotia, Aug 1974, pp 373-377.
- Sheets, H. E., "Energy Recovery From Fluid Motion," Proceedings, MacArthur Workshop on the Feasibility of Extracting Usable Energy From the Florida Current, Palm Beach Shores, Florida, Feb-Mar 1974.
- Shoupp, W. E., "Involving the Oceans in Solving Energy Problems," Marine Technology Society Journal, Vol. 8, No. 2, Feb 1974, pp 18-24.
- Stahl, A., "The Utilization of the Power of Ocean Waves," Transactions of the American Society of Mechanical Engineers, Vol. 13, 1892, pp 438-505.
- Steelman, G. E., "An Invention Designed to Convert Ocean Currents into Usable Power," Proceedings, MacArthur Workshop on the Feasibility of Extracting Usable Energy From the Florida Current, Palm Beach Shores, Florida, Feb-Mar 1974.

Swales, M. C., "The Role of Tidal Energy in an Electric Supply System and Factors Affecting Its Economic Choice," Proceedings International Conference on Engineering in the Ocean Environment, Institute of Electrical and Electronic Engineers, Halifax, Nova Scotia, Aug 1974, pp 384-387.

Swift-Hook, D. T. et al., "Characteristics of a Rocking Wave Power Device," Nature, Vol. 254, No. 5500, 10 Apr 1975, pp 504-506.

Terry, R. D., (ed.), "Energy Sources and Energy Conversion," Ocean Engineering, Vol. 5, Part I, North American Aviation, El Segundo, California.

Turley, B., "Generation of Power from Ocean Waves," Alternate Sources of Energy, Sep-Oct 1972, pp 5-8.

U.S. Patent Office, Patent Search, "Utilizing Ocean Waves as a Power Source," 3 Dec 1974.

Whitehead, P. L. and Gazel, H. A., "Sea Wave Electric Power System," Proceedings Engineering in the Ocean Environment Conference, Institute of Electrical and Electronic Engineers, 1971, pp 159-160.

Wick, G., "Wave Powered Generator," Sea Grant University of California, Vol. 1, No. 1, Mar 1973.

Wilson, E. M., "Energy From the Sea-Tidal Power," Underwater Journal, Vol. 5, No. 4, Aug 1973, pp 175-186.

Wilson, E. M., "Tidal Energy and Its Development," Proceedings of Conference on Engineering in the Ocean Environment, Institute of Electrical and Electronic Engineers, Newport, Rhode Island, Sep 1972, pp 48-56.

Zener, C., "Solar Sea Power," Physics Today, Vol. 26, No. 1, Jan 1973, pp 48-53.

Manufacturers

James Leffel & Co.
Springfield, OH 45501
(513) 323-6431

Tidelands Signal Corporation
4310 Directors Row
Houston, TX 77018
(713) 681-6101

Local data source

1. Publications:

Bretschneider, C. L. and Gaul, R. D., "Wave Statistics for the Gulf of Mexico Off Brownsville, Texas," Technical Memo 85, Army Corps of Engineers, Beach Erosion Board, Washington, D.C., Sep 1956.

Bretschneider, C. L. and Gaul, R. D., "Wave Statistics for the Gulf of Mexico Off Capler, Texas," Technical Memo 86, Army Corps of Engineers, Beach Erosion Board, Washington, D.C., Sep 1956.

Darling, J. M., "Surf Observations Along the United States Coasts," Journal of Waterways and Harbors Division, American Society of Civil Engineers, Vol. 94, No. WWI, pp 11-21.

"Environmental Conditions Within Specified Geographical Regions - Offshore East and West Coasts of the United States and in the Gulf of Mexico," National Oceanic and Atmospheric Administration, Data Buoy Office, Rockville, Maryland, Aug 1973.

"General Data for the Delaware River, Part I, Long Range Spoil Disposal Study," Army Engineer District, Philadelphia, Corps of Engineers, Jun 1969.

Ruzecki, P. and Agres, R., "Suspended Sediments Near Pier 12 Norfolk Navy Base on 26 June and 15 September 1973," Data Report No. 11, Virginia Institute of Marine Science, Gloucester Point, Virginia, Oct 1974.

"Sea and Swell," Oceanographic Atlas of the North Atlantic Ocean, Section IV, Publication No. 700, Naval Oceanographic Office, Washington, DC, 1963.

Thompson, E. F. and Harris, D. L., "A Wave Climatology for U.S. Coastal Waters," Proceedings Offshore Technology Conference, May 1972, Paper No. 1693.

"Tidal Current Tables, Pacific Coast of North America and Asia," National Oceanic and Atmospheric Administration, National Ocean Survey, Annual.

"Tidal Current Tables, Atlantic Coast of North America," National Oceanic and Atmospheric Administration, National Ocean Survey, Annual.

"Tide Tables, West Coast of North and South America," National Oceanic and Atmospheric Administration, National Ocean Survey, Annual.

"Tide Tables, East Coast of North and South America," National Oceanic and Atmospheric Administration, National Ocean Survey, Rockville, Maryland, Annual.

"Tides and Currents," Oceanographic Atlas of the North Atlantic Ocean, Section I, Publication No. 700, Naval Oceanographic Office, Washington, D.C., 1965.

Urban, H. D. and Galvin, C. J., "Pipe Profile Data and Wave Observations from the CERC Beach Evaluation Program, January-March 1968," Miscellaneous Paper No. 3-69, Coastal Engineering Research Center, Washington, D.C., Sep 1969.

Sources for nine sites

Chesapeake Bay Institute
The Johns Hopkins University
Baltimore, MD 21218

Department of Oceanography
University of Washington
Seattle, WA 98105
(206) 543-5078

Department of Oceanography
Oregon State University
Corvallis, OR 97331
(503) 754-3504

Great Lakes Research Division
Department of Meteorology and
Oceanography
University of Michigan
Ann Arbor, MI 48104
(303) 763-3183

Institute of Oceanography
Old Dominion University
Norfolk, VA 23508
(804) 489-6476

Institute of Storm Research
University of St. Thomas
4104 Mount Vernon
Houston, TX 77006
(713) 529-4891

Scripps Institution of
Oceanography
Box 109
La Jolla, CA 92037
(714) 452-2230

U.S. Geological Survey
National Center
Reston, VA 22092
(703) 860-6867

Woods Hole Oceanographic Institution
Woods Hole, MA 02543
(617) 548-1400

Director
Data Services Division, D76
National Oceanic and Atmospheric
Administration
Washington, DC 20235
(202) 674-7500

Gulf University Research Corporation
227 System Building
College Station, TX 77843
(713) 846-2453

Institute of Ocean Science and
Engineering
Catholic University of America
Washington, DC 20017
(202) 635-5000

National Oceanographic Data Center
Environmental Data Center
2001 Wisconsin Avenue
Washington, DC 20235
(202) 634-7500

U.S. Army Coastal Engineering Research
Center
Kingman Building
Leaf and Telegraph Roads
Fort Belvoir, VA 22060
(202) 325-7393

Virginia Institute of Marine Science
Gloucester Point, VA 23062
(804) 642-2111