

AD-A048 184

ARMY ENGINEER DIV NORTH PACIFIC BONNEVILLE OREG DIV --ETC F/G 13/2
FISH LADDER FOR CHARLES RIVER DAM CHARLES RIVER, MASSACHUSETTS.--ETC(U)
DEC 77 L Z PERKINS, P M SMITH

UNCLASSIFIED

TR-157-1

NL

| 9 |

ADAD48 184

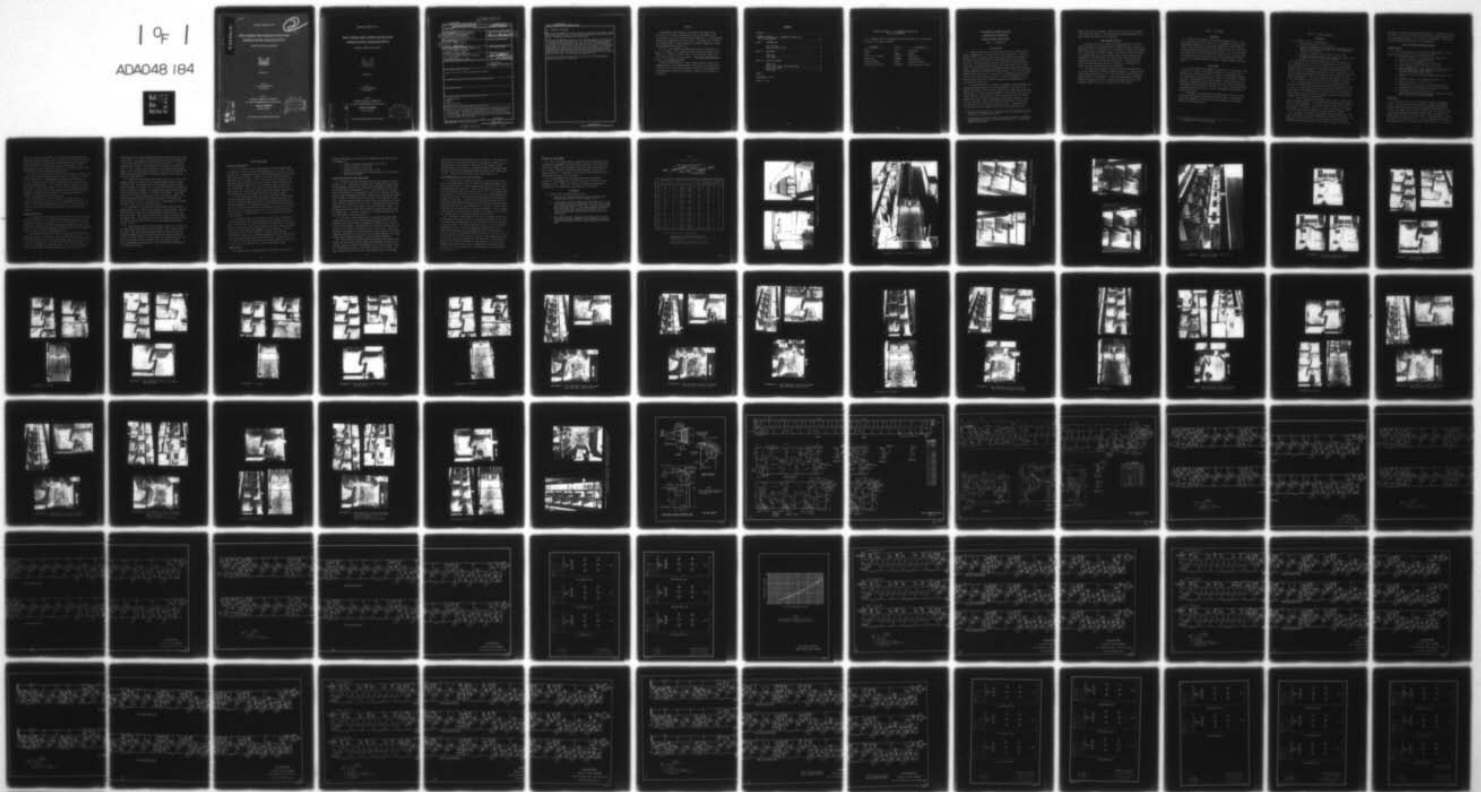

END

DATE

FILMED

1-78

DDC

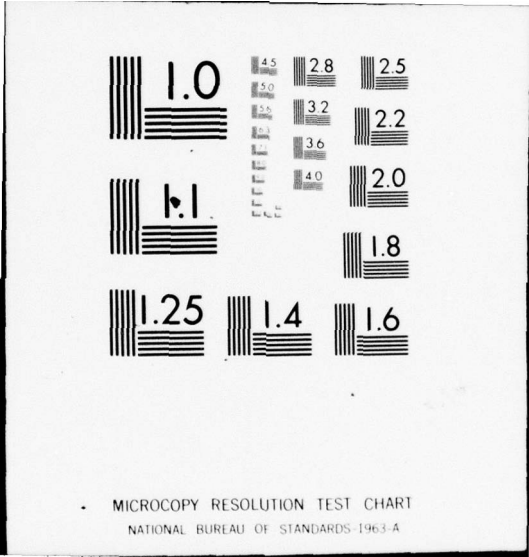

ADA 048184

TECHNICAL REPORT NO. 157-1

2

FISH LADDER FOR CHARLES RIVER DAM
CHARLES RIVER, MASSACHUSETTS

HYDRAULIC MODEL INVESTIGATION

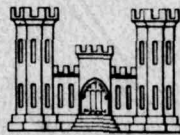

DECEMBER 1977

SPONSORED BY
U.S. ARMY ENGINEER DIVISION
NEW ENGLAND

CONDUCTED BY
DIVISION HYDRAULIC LABORATORY
U.S. ARMY ENGINEER DIVISION, NORTH PACIFIC
CORPS OF ENGINEERS
BONNEVILLE, OREGON

DDC
RECEIVED
JAN 9 1978
D

AD No. _____
DDC FILE COPY

THIS DOCUMENT HAS BEEN APPROVED FOR PUBLIC RELEASE

TECHNICAL REPORT NO. 157-1

FISH LADDER FOR CHARLES RIVER DAM CHARLES RIVER, MASSACHUSETTS

HYDRAULIC MODEL INVESTIGATION

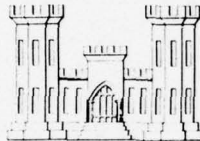

DECEMBER 1977

SPONSORED BY
U.S. ARMY ENGINEER DIVISION
NEW ENGLAND

CONDUCTED BY
DIVISION HYDRAULIC LABORATORY
U.S. ARMY ENGINEER DIVISION, NORTH PACIFIC

CORPS OF ENGINEERS
BONNEVILLE, OREGON

THIS DOCUMENT HAS BEEN APPROVED FOR PUBLIC RELEASE

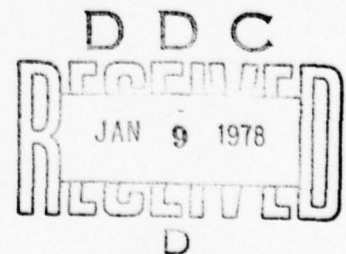

ACCESSION NO.	
RTIS	<input checked="" type="checkbox"/>
DDC	<input type="checkbox"/>
WHANPOUNDER	<input type="checkbox"/>
JUSTIFICATION	
BY	
DISTRIBUTION PRIORITY CODES	
Dist.	SPECIAL
A	

14 TR-157-1

Unclassified

SECURITY CLASSIFICATION OF THIS PAGE (When Data Entered)

REPORT DOCUMENTATION PAGE		READ INSTRUCTIONS BEFORE COMPLETING FORM
1. REPORT NUMBER Technical Report No. 157-1 ✓	2. GOVT ACCESSION NO.	3. RECIPIENT'S CATALOG NUMBER
4. TITLE (and Subtitle) 6 FISH LADDER FOR CHARLES RIVER DAM CHARLES RIVER, MASSACHUSETTS, Hydraulic Model Investigation.		5. TYPE OF REPORT & PERIOD COVERED 9 Final report. Sep 73-Mar 75
7. AUTHOR(s) 10 L. B. PERKINS P. M. SMITH		6. PERFORMING ORG. REPORT NUMBER
8. PERFORMING ORGANIZATION NAME AND ADDRESS U. S. Army Engineer Division, North Pacific Division Hydraulic Laboratory Bonneville, Oregon 97008 ✓		6. CONTRACT OR GRANT NUMBER(s)
11. CONTROLLING OFFICE NAME AND ADDRESS U. S. Army Engineer Division, New England 424 Trapelo Road Waltham, Massachusetts 02154		10. PROGRAM ELEMENT, PROJECT, TASK AREA & WORK UNIT NUMBERS
14. MONITORING AGENCY NAME & ADDRESS (if different from Controlling Office)		12. REPORT DATE 11 Dec 1977
		13. NUMBER OF PAGES 62 (1285p.)
		15. SECURITY CLASS. (of this report) Unclassified
		15a. DECLASSIFICATION/DOWNGRADING SCHEDULE
16. DISTRIBUTION STATEMENT (of this Report) Approved for public release, distribution unlimited.		
17. DISTRIBUTION STATEMENT (of the abstract entered in Block 20, if different from Report)		
18. SUPPLEMENTARY NOTES		
19. KEY WORDS (Continue on reverse side if necessary and identify by block number) Hydraulic models Fishways Weirs Charles River Dam		
20. ABSTRACT (Continue on reverse side if necessary and identify by block number) The design of a fish ladder that would operate with downstream tide fluctuations of 14 ft and upstream river fluctuations of 1 ft were developed in two hydraulic models. The hydraulic design of the ladder was developed in a 1:8-scale model. Hydraulic characteristics of a false weir at the upstream end of the ladder were studied in a 1:4-scale model. The ladder was intended to pass primarily shad and alewives.		

(Continued)

408953

Handwritten signature

Unclassified

SECURITY CLASSIFICATION OF THIS PAGE(When Data Entered)

20. ABSTRACT (continued)

The initial fish ladder was of the vertical-slot type with 29 pools and a false weir above high tide level to lead fish into a steep chute to the river 6.5 ft below. The design was hydraulically satisfactory.

The design was modified to include a direct swim-through exit to the river for use during low and intermediate tides. The low tide ladder section consisted of five pools with notched weirs and a weir gate exit. The false weir exit was designed to operate with all tide levels, but fish were to be blocked from that section by a barrier rack during use of the low tide exit. In a further modification, the notched weirs of the low tide section were replaced with a submerged screen barrier that would force fish toward the surface for better public viewing. With that plan, the false weir exit operated only when the low tide exit was closed. All the plans were satisfactory.

The plan with a false weir exit and a low tide exit with submerged barrier screen was selected for construction.

Unclassified

SECURITY CLASSIFICATION OF THIS PAGE(When Data Entered)

PREFACE

The hydraulic model studies in this report were authorized by the Office of the Chief of Engineers in the 1st indorsement, dated 18 July 1973, to a letter from the Division Engineer, U. S. Army Engineer Division, New England, dated 10 July 1973. The studies were conducted at the North Pacific Division Hydraulic Laboratory, Bonneville, Oregon from September 1973 to March 1975.

Mr. D. E. Fox conducted the model tests under the supervision of Mr. T. D. Edmister. The studies were under the general supervision of Messrs. A. J. Chanda (retired), Chief of the Hydraulics Branch, and P. M. Smith, Director of the Laboratory. This report was prepared by Messrs. L. Z. Perkins and Smith.

During the studies Messrs. George Sarandis and Saul Cooper, New England Division, and representatives of the Bureau of Sport Fisheries and Wildlife and the Division of Marine Fisheries of the Commonwealth of Massachusetts visited the Laboratory to observe flow conditions in the models.

CONTENTS

PREFACE	1
CONVERSION FACTORS, U. S. CUSTOMARY TO METRIC (SI)	
UNITS OF MEASUREMENT	iii
PART I: INTRODUCTION	1
The Prototype	1
Need for Model Studies	2
PART II: THE MODELS	3
False Weir	3
Fish Ladder	3
PART III: TESTS AND RESULTS	4
False Weir	4
Plan A Fish Ladder (Original Design)	5
Plan B Fish Ladder	8
Conclusions	11

TABLE A

PHOTOGRAPHS 1 TO 18

PLATES 1 TO 20

CONVERSION FACTORS, U. S. CUSTOMARY TO METRIC (SI)
UNITS OF MEASUREMENT

U. S. customary units of measurement used in this report can be converted to metric (SI) units as follows:

<u>Multiply</u>	<u>By</u>	<u>To Obtain</u>
inches	2.54	centimeters
feet	0.3048	meters
miles (U. S. statute)	1.609344	kilometers
square feet	0.092903	square meters
feet per second	0.3048	meters per second
cubic feet per second	0.0283168	cubic meters per second

FISH LADDER FOR CHARLES RIVER DAM

CHARLES RIVER, MASSACHUSETTS

Hydraulic Model Investigations

PART I: INTRODUCTION

The Prototype

1. Charles River Dam is located at mile 0.7 on the Charles River in Boston, Massachusetts.* The river flows into Boston Harbor. When completed in 1977, the project will provide flood control and navigation on the river and will be a barrier to tidal fluctuations and salt water intrusion. The earthfill and concrete structure will have three navigation locks, a six-unit pumping station, two outlet sluices, and a fish ladder. The dam will replace an existing structure 2,250 ft upstream that has one navigation lock and limited flood control. At the dam, the normal upstream river level will be at elev 180.** Occasionally the level will drop 1 ft and, during floods, rise 2 ft. The tide downstream will rise and fall twice daily with a maximum fluctuation of approximately 15 ft from elev 98 to elev 112.6.

2. The vertical-slot fish ladder is designed to pass anadromous fish, principally shad and alewives, from Boston Harbor to the river at all normal tide levels. The 14-ft-wide, 144.8-ft-long ladder has one entrance and two exits. One exit provides passage for fish directly into the river during low tide. The other exit is above high tide level and provides passage over a false weir (also called a hollow weir) and down a steep chute to the river. Water in the ladder is provided by the false weir or, when open, by a weir gate in the low tide exit. Additional water for attraction flow is pumped from the river and supplied to three

* Factors for converting U. S. customary units of measurement to metric (SI) units are listed on page iii.

** All elevations are in feet above the Metropolitan District Commission Datum, which is 105.65 ft below mean sea level, the U. S. Coast and Geodetic Survey Datum.

ladder pools near the entrance. Fish viewing for visitors is provided in the low tide exit section. The modified plan B design developed in the model studies was adopted for the prototype.

Need for Model Studies

3. The vertical-slot fish ladder was selected because it had been used successfully to pass shad and other anadromous fish at John Day and Bonneville Dams on the Columbia River and because the ladder would operate with a large range of tailwater depths. The ladder for Charles River was to be smaller than those on the Columbia River, to pass relatively more discharge per unit flow volume, and to have depth fluctuated from the downstream end rather than from the upstream end. A model study was needed to supply design information for elements of the ladder and to assure that flow conditions would be satisfactory.

4. The false weir proposed for the high tide exit had been used in the Pacific Northwest in research trapping facilities, in temporary fish ladders during construction, and in fish hatcheries; however, hydraulic design data were not available. A model study was needed to determine hydraulic characteristics and to develop any changes required to meet hydraulic design criteria for the Charles River fish ladder.

PART II: THE MODELS

False Weir

5. Details of the proposed false weir are shown on plate 1. The weir, which was modeled to a scale of 1:4 (photograph 1), had an inflow dissipation chamber in the bottom that connected to a vertical supply shaft. Vanes near the top of the shaft deflected most of the flow over a weir that formed the downstream side of the shaft. The top of the shaft was covered with a grill to prevent fish from entering. The false weir was constructed of clear acrylic plastic, the grill was made of metal rods, and the outflow channels were built of plywood, plastic, and sheet metal.

Fish Ladder

6. The fish ladder was modeled to a scale of 1:8. The original model consisted of a 29-pool, vertical-slot ladder with a false weir exit, auxiliary water diffusers in pools 2, 4, and 6, a floating weir entrance, and a 24-ft-wide, 64-ft-long section of harbor at the entrance.* Details are shown in photographs 2 and 3 and on plate 2. Later, the design was modified to include a five-pool section of ladder for use during low and intermediate tides (photograph 4 and plate 3). Flow to that section would be controlled by a weir gate at the exit. The model was constructed of plywood and plastic.

7. Discharges in both models were measured with V-notch weirs, and velocities were measured with miniature current meters. Model measurements were converted to prototype values with equations of similitude based on the Froude model law.

* All dimensions are in prototype values.

PART III: TESTS AND RESULTS

False Weir

8. Hydraulic criteria for design were:

- a. Downstream discharge to ladder, 15 cfs.
- b. Upstream discharge to river, sufficient to produce depths of 0.08 to 0.2 ft (enough to lubricate fish but inadequate for swimming back over weir).
- c. Velocity at downstream edge of weir, 5.0 to 6.5 fps.
- d. Tailwater on downstream side of weir, sufficient depth at weir to permit fish to swim over without jumping.

9. The design flow condition selected for use in the ladder was a total discharge of 16.5 cfs (15.0 cfs downstream and 1.5 cfs upstream) with tailwater level with the top of the weir to provide swim-through passage for fish (photograph 5). The minimum upstream depth was 0.12 ft, and the velocity at the downstream edge was 6.2 fps. Flow conditions with the same downstream discharge and higher and lower tailwaters are also shown in photograph 5. All three conditions, which might occur during use in the fish ladder, were satisfactory and met the hydraulic criteria.

10. A discharge rating of the weir and flow characteristics with varied inflow, downstream discharges, and tailwater elevations are listed in table A. With tailwater levels lower than elev 114.18, especially in the vicinity of the downstream lip of the weir at elev 113.83, the downstream outflow nappe oscillated, and constant downstream discharges and tailwater levels could not be maintained.

11. In the original design, the guide vanes in the weir supply shaft had no stiffening elements. A stiffening bar and gusset plates, shown on plate 1, were recommended. In the model, where the vanes were scaled to the correct size in plastic but not to the correct rigidity, the largest vanes failed from vibration before the gusset plates were added.

12. A bypass of a portion of the upstream flow was proposed for control of flow depth in the chute independent of downstream conditions. The bypass was a well in the top of the weir adjacent to the supply shaft through which controlled amounts of flow could be bypassed to the river.

The well was covered with a grating that extended 1.5 ft upstream from the weir crest. Tests in the model indicated that the proposed bypass and one with the grating shortened to 0.4 ft were not satisfactory. The grating bars were exposed when the bypass was in operation.

Plan A Fish Ladder (Original Design)

Design Criteria

13. The initial design for the fish ladder (photographs 2 and 3 and plate 2) was developed to meet the following criteria:
 - a. Entrance discharge for fish attraction, about 50 cfs.
 - b. Entrance velocity, approximately 8 fps.
 - c. Tide limits for good operation, elev 98 to 112.
 - d. Ladder discharge supplied by false weir, 15 cfs.
 - e. Exit discharge (flow of false weir to exit chute), 1.23 to 2.70 cfs (discharge to create depths of 1 to 3 in. at upstream end of transition to chute).
 - f. Attraction velocity at downstream edge of false weir, 4 to 7 fps.
 - g. Minimum pool depth, 5 ft; minimum slot width, 1 ft.
 - h. Ladder slot velocity, 1.0 to 7.5 fps.
 - i. Diffuser velocity, less than 1 fps (gross opening area).
 - j. Continuous path of downstream flow from exit to entrance.
 - k. No upwelling to attract and delay fish.
 - l. Water depth downstream from false weir, sufficient to permit fish to swim over weir without jumping.

Description

14. The pools were basically rectangular in plan with chamfered corners. The slots connecting the pools were formed by overlapping walls of adjacent pools; flow was directed along the walls from slot to slot. The slots varied in area to regulate the flow velocity. Slots 2 to 6, which passed more discharge than the others, extended to the ladder floor (no sills) and varied in width. The others were 1 ft wide and had sills to restrict the area. The floor sloped from elev 92.0 at the downstream end of the ladder to elev 103.0 in pool 22. The floor in

pools 23 to 29 was at elev 103.0. The floor of the upstream pools was lower than otherwise needed so that, if necessary, a low tide exit section could be added to the prototype with minimum removal of mass concrete. Twelve pools had low sills and pool 1 had a wall deflector. These features and the corner chamfers would direct the flow into a nearly horizontal path and prevent upwelling along the walls.

15. The 15-cfs discharge of the ladder was increased to 50 cfs at the entrance with flow from wall diffusers in pools 2, 4, and 6 (15, 10, and 10 cfs, respectively). The maximum gross-diffuser-area velocity was 0.6 fps. Vertical bars with 5/8-in. openings were used to prevent fish from entering the diffusers. The bars were skewed 45 degrees to attract fish across the grill and to direct the flow into the normal path along the walls. The ends of the diffuser supply pipes were baffled with horizontal bars skewed downward 45 degrees to eliminate upwelling in the diffuser and outflow that might confuse fish.

16. The entrance was a slot with sill at elev 96.0 (slot 1). A 3-ft-wide floating weir located in the slot and ballasted to float 2 ft below bay level automatically controlled the flow. A constant flow area of 6 sq ft was provided with all tide levels for the 50-cfs entrance discharge.

Flow Characteristics

17. Velocities and flow directions in the ladder for six tide levels are shown on plates 4 to 6. Velocities are shown at each slot, in pools with special shapes or flow conditions, and in typical pools 17 and 18. Velocities of attraction flow at the entrance are shown on plates 7 and 8. Surface flow conditions with minimum and maximum tides and an intermediate tide, elev 105, are shown in photographs 6 to 8.

18. Flow from the false weir created a broad downstream flow path along the surface in the exit pool (29) to attract fish to the weir. The attraction velocity at the weir was acceptable, from 6.7 fps with low tide to 4.6 fps with high tide. The downstream flow of the weir was 15 cfs except at the highest tide, elev 112, when it was 14 cfs. The water surface of pool 29 varied from approximately elev 114.4 to 115.1, which

would permit fish to swim rather than jump over the false weir with crest at elev 114.5. The false weir discharge into the exit chute varied from 1.23 cfs with tide elev 98 to 2.64 cfs with tide elev 112. Those discharges produced depths at the transition from the weir to the chute of 1.0 to 2.9 in. Because of the difficulty of accurately measuring small depths in the 1:8-scale model, discharges to the chute were measured, and depths were determined from the rating data observed in the 1:4-scale false weir model (plate 9).

19. Velocities in the ladder slots varied from 1.1 to 7.3 fps. The minimum velocity occurred at slot 11 during maximum flooding of pools (tide elev 112). The maximum velocity was measured in slot 20 during partial flooding at tide elev 103. A continuous flow path at and near the surface existed in the ladder. No upwelling that would attract and delay fish occurred along the walls or in corners of the pools. The minimum velocity in the flow path was greater than 1 fps except in pools 3 to 6 and 29 during flooding with tide elev 110 and 112. The minimum was observed in pool 6 (0.4 fps, tide elev 112). Minimum depth in the ladder was about 5.4 ft in pool 5 with tide elev 98.

20. Performance of the auxiliary water diffusers was satisfactory (photographs 6 to 8). There was no upwelling in the diffusers. The outflow was nearly uniform with a slightly greater outflow near the floor during low tides. Less uniform, lower-velocity outflow occurred during the higher tides. Good attraction flow with acceptable velocities across the diffuser grills would lead fish to the slot immediately upstream (plates 4 to 6).

21. The attraction velocity at the entrance (slot 1) was 8.1 fps for all tides except the minimum, elev 98 (9.0 fps). The 9.0-fps velocity was higher than desired but acceptable because it would occur briefly during an extremely low tide and because shad have passed through that velocity in other fishways. The attraction flow penetrated into the bay 50 ft or more with a velocity greater than 1 fps (plates 7 and 8). Before dissipating to a velocity of 1 fps the attraction stream was over 7 ft deep and 10 ft wide.

Plan B Fish Ladder

Purpose and Description

22. At the request of the fishery agencies, the fish ladder design was modified to provide a direct swim-through exit to the river. The exit was to assure a passageway during low and intermediate tides for fish that might reject the false weir. Details of the plan B ladder are shown in photograph 4 and on plates 1 and 3. The pools from the entrance to the false weir were essentially like those in plan A except that pools 19 to 29 were narrowed to allow space for a 4-ft-wide section of ladder with four notched weirs, floor at elev 103.0, and flow controlled by a weir gate at the exit. Weirs with notched crests would control discharge and flow depth and direct fish toward the surface for public viewing.

23. Since less energy losses would cause lower water-surface elevations in the narrower pools, the false weir was lowered from elev 114.5 to 114.3 to provide enough flow depth in the upstream transition during low tide conditions. The diffusers in pools 2, 4, and 6 were the same as plan A. The 3-ft-wide entrance weir was ballasted to float 2.5 ft below the bay level to provide a flow area of 7.5 sq ft with all tide levels above elev 98.5. A minimum area of 6 sq ft was provided at extreme low tide, elev 98.0.

24. During low tides, a barrier rack in pool 17 near the middle of the ladder would prevent fish from entering pools leading to the false weir. Flow over the exit weir and notched weirs would attract fish from pool 17 to the river. The exit weir would be closed (in raised position) when the low tide ladder was submerged by rising tailwater. The top of the barrier in pool 17 was level with the normal river elevation. During higher tides, the rack would be submerged, and fish would pass over it to the ladder section with the false weir exit. With the river at elev 108.0, low tide exit could be used during tide levels below elev 106. The false weir exit would have to be used during higher tides.

Design Criteria

25. Except for the following changes, the hydraulic criteria for

design and development of the plan B fish ladder were the same as those in paragraph 13:

- a. Entrance discharge, approximately 50 to 62 cfs.
- b. Ladder discharge, 15 to 27 cfs.
- c. Maximum low tide exit discharge, 12 cfs.
- d. Limits for good operation, tide elev 98.5 to 112.0 and river elev 107.5 to 108.5.

Flow Characteristics in Main Fish Ladder

26. Velocities and flow directions for five tide levels are shown on plates 10 to 19. Surface flow conditions with minimum and maximum tides and intermediate tides near the upper limit of operation in the low tide section are shown in photographs 9 to 15. Flow conditions at the false weir and performance of the diffusers in pools 2, 4, and 6 were similar to those in plan A (paragraphs 18 and 20, respectively). Reducing the ladder width in pools 19 through 29 had little effect on flow patterns in that area. Although slightly higher than with plan A, slot velocities in those pools met the criterion of 1.0 to 7.5 fps. Velocities and flow patterns downstream from pool 17 were similar to those in the plan A ladder. The minimum velocity in the flow path (0.6 fps) was observed in pool 6 with the highest tide. Attraction conditions at the ladder entrance (slot 1) were also similar to those with plan A.

27. With only two minor exceptions, flow velocities in the ladder downstream from pool 17 were within design limitations when the 15-cfs discharge over the false weir was augmented by flows of 1.5 to 10.8 cfs in the low tide ladder. With maximum river elev 108.5, velocity near the bottom of slot 12 was 7.8 fps; near the top it was 7.1 fps. With tide elev 98.5, an extremely low tide that would occur for only a brief period, a maximum velocity of 9.4 fps existed at the fishway entrance. No design changes were considered necessary to alleviate these conditions.

28. Flow conditions with an alternative operation that might be used during low tide if the 4-ft-wide ladder was inoperative and the barrier rack was removed are shown in photographs 16 and 17 and on plates 14 and 19. The attraction velocity to the false weir was 5.8 to 5.9 fps. The water surface in pool 29, elev 114.2, would permit fish to swim rather

than jump over the false weir with crest at elev 114.3. The exit flow of the weir was 1.23 cfs, and the depth at the transition from the weir to the chute was 1.0 in. (plate 9). Velocities in the ladder, at the entrance, and in the bay were of the same magnitude as those with normal operation except that the maximum entrance velocity was 8.4 rather than 9.4 fps. The attraction discharge was 50 rather than 61 cfs.

Flow Characteristics in Low Tide Fish Ladder

29. The weir gate of the low tide exit was set at elev 106.5 when open. With normal river level, elev 108.0, the maximum discharge in the low tide section was 8 cfs and the maximum velocity was 3.5 fps at the minimum design tide (plate 11). Depths across notches of the weirs were least with minimum tide and varied from 10 to 17 in. The maximum attraction velocity to the section at pool 17 was 4.0 fps, and the maximum exit velocity was 1.8 fps. All the velocities decreased as the section was flooded by rising tide. In pool 17 flow from the false weir section of the ladder passed through the barrier rack and increased flow that swept along the walls to slot 17 (photographs 9, 11, and 15). The flow pattern would lead fish along the walls to the section entrance. Fish attracted to the barrier rack would find the entrance at one side and an attraction flow leading back to the main flow path on the other side.

30. Velocities in the ladder with the river at maximum and minimum design levels, elev 108.5 and 107.5, are shown on plates 10 and 13. With river elev 108.5 (photographs 9 and 10), the low tide exit was operative to tide elev 106.5. The maximum exit velocity was 2.1 fps, the maximum discharge was 10.8 cfs, and the maximum notch velocity was 3.6 fps. Other velocities were of the same magnitude as those with the normal river level except the previously-mentioned velocity of 7.8 fps in slot 12 at tide elev 98.5. With the river at elev 107.5 (photographs 14 and 15), the low tide section was operative to tide elev 105.5. The maximum exit velocity was 1.8 fps, the maximum exit discharge was 4.7 cfs, and the maximum notch velocity was 4.6 fps. Minimum depths across the notches were 8 to 11 in. at minimum tide. The minimum depth in the ladder was 6.7 ft in pool 1.

Modified Low Tide Ladder

31. One of the fishery agencies suggested that the notched weirs be replaced by a submerged screen barrier the full width of the section and that all the ladder flow be supplied through that exit during operation at low tides. Details of the modifications developed in the model are shown on plate 20. In addition, a 2-ft-high sill was required in pool 17, and the exit weir was set at elev 106.0.

32. Flow conditions with the modifications were satisfactory (plate 20). With minimum tide elev 98.5 and river elev 108.0, the discharge was 23 cfs. Those flow conditions are shown in photograph 18. Discharge was not adequate with tide levels above elev 106.0.

Conclusions

33. Tests in the two models indicated that:

- a. The plan A fish ladder (false weir exit only) functioned satisfactorily and met hydraulic design criteria.
- b. A modification having an additional swim-through exit to the river (plan B) was also satisfactory. The exit could be used with tides lower than elev 106. The false weir would provide exit with higher tides. An alternative method of operation with the low tide exit closed and the barrier in pool 17 removed would provide fish exit over the false weir at all tide levels.
- c. Flow conditions were acceptable with tides lower than elev 106 when a full-width submerged screen replaced the notched weirs and all ladder flow was supplied through the low tide exit.

TABLE A

FALSE WEIR FLOW CHARACTERISTICS

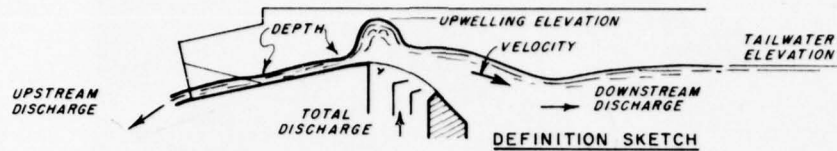

Discharge in CFS			Water-Surface Elevations		Upstream Flow Depths in Feet		Velocity at Downstream Edge of Weir in FPS
Total	Downstream	Upstream	Tailwater	Upwelling	Toe of Upwelling	Upstream End of Transition	
13.1	12.0	1.1	114.18	114.98	0.08	0.06	6.5
13.3	12.0	1.3	114.50	115.04	0.08	0.06	6.0
13.6	12.0	1.6	114.75	115.12	0.10	0.10	5.5
14.4	12.0	2.4	115.00	115.28	0.18	0.20	4.7
16.4	15.0	1.4	114.18	115.19	0.10	0.08	7.0
16.5	15.0	1.5	114.50	115.25	0.12	0.10	6.2
16.8	15.0	1.8	114.75	115.34	0.14	0.14	6.0
17.5	15.0	2.5	115.00	115.45	0.20	0.22	5.8
19.6	18.0	1.6	114.18	115.30	0.12	0.12	7.6
19.7	18.0	1.7	114.50	115.37	0.14	0.14	7.0
20.0	18.0	2.0	114.75	115.55	0.16	0.18	6.7
20.6	18.0	2.6	115.00	115.70	0.20	0.24	6.5
10.0	9.3	0.7	114.18	114.82	0.06	0.04	5.8
10.0	9.1	0.9	114.50	114.88	0.08	0.06	5.1
10.0	8.7	1.3	114.75	114.97	0.10	0.08	3.9
10.0	7.8	2.2	115.00	115.07	0.16	0.16	3.1
13.0	12.0	1.0	114.18	114.95	0.08	0.06	6.6
13.0	11.8	1.2	114.50	115.01	0.10	0.08	5.8
13.0	11.4	1.6	114.75	115.09	0.12	0.10	4.6
13.0	10.7	2.3	115.00	115.23	0.16	0.18	4.1
16.5	15.1	1.4	114.18	115.20	0.10	0.08	7.0
16.5	15.0	1.5	114.50	115.25	0.12	0.12	6.2
16.5	14.7	1.8	114.75	115.32	0.14	0.14	5.8
16.5	14.0	2.5	115.00	115.40	0.18	0.20	5.2
20.0	18.4	1.6	114.18	115.40	0.14	0.14	7.4
20.0	18.2	1.8	114.50	115.42	0.14	0.14	7.0
20.0	18.0	2.0	114.75	115.54	0.16	0.18	6.7
20.0	17.4	2.6	115.00	115.62	0.20	0.24	6.2

- NOTES: 1. Details of false weir are shown on plate 1.
2. Tailwater gage was 15.2 ft from downstream side of weir; upstream depth was measured at transition from weir to chute, 2.28 ft upstream from weir crest. Data were observed along center line of weir.
3. Fluctuating upstream depths and downstream velocities caused variations of 0.03 ft in depths and 0.1 to 0.2 ft in velocities.

TABLE A

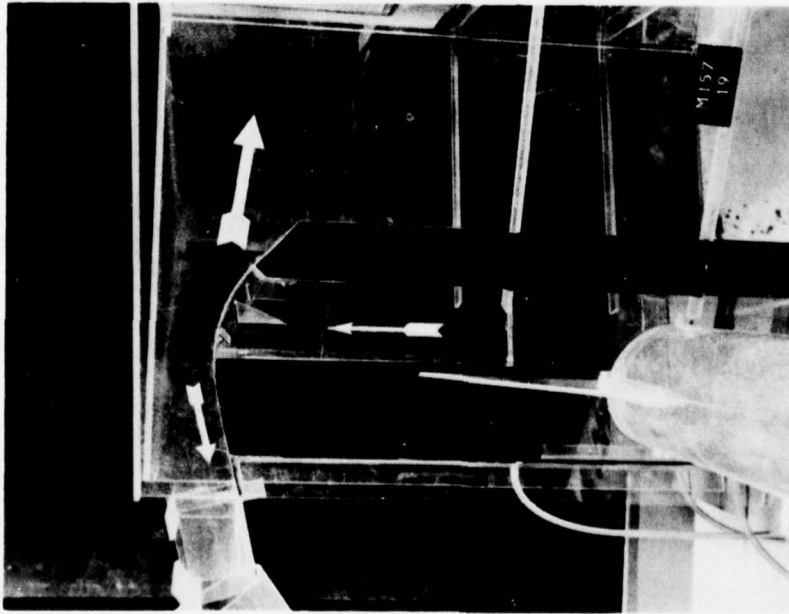
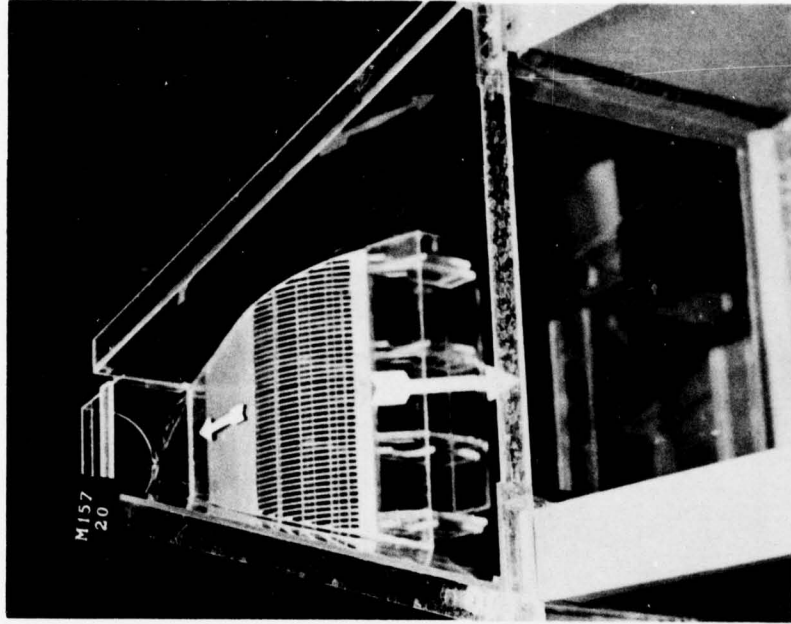

Photograph 1. False weir in 1:4-scale model.

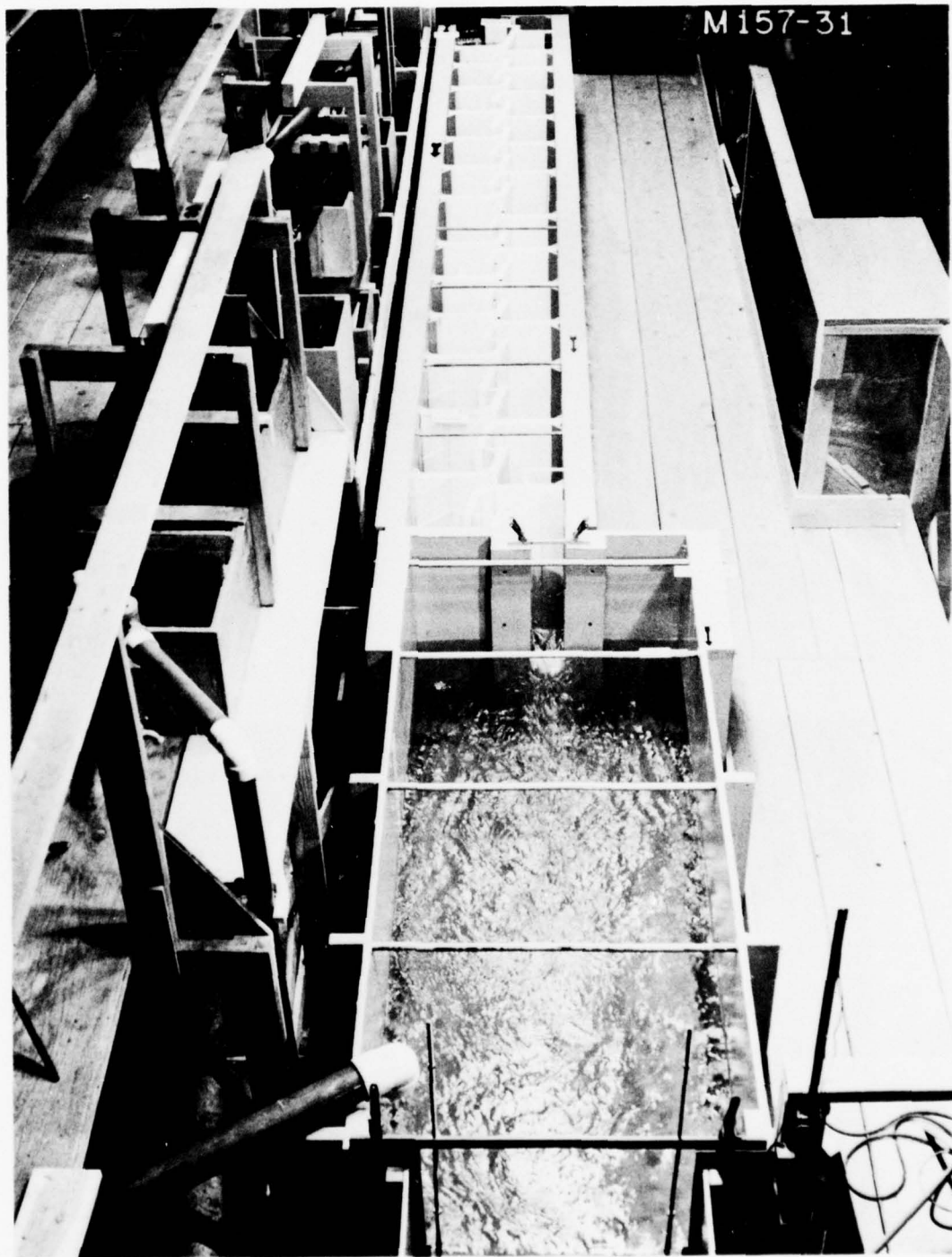

Photograph 2. Plan A fish ladder in 1:8-scale model.

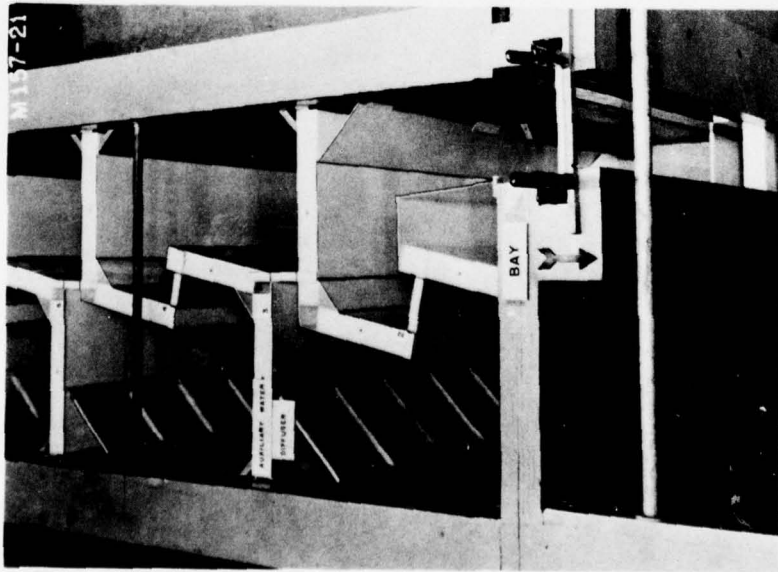

Entrance and pools 1 to 4

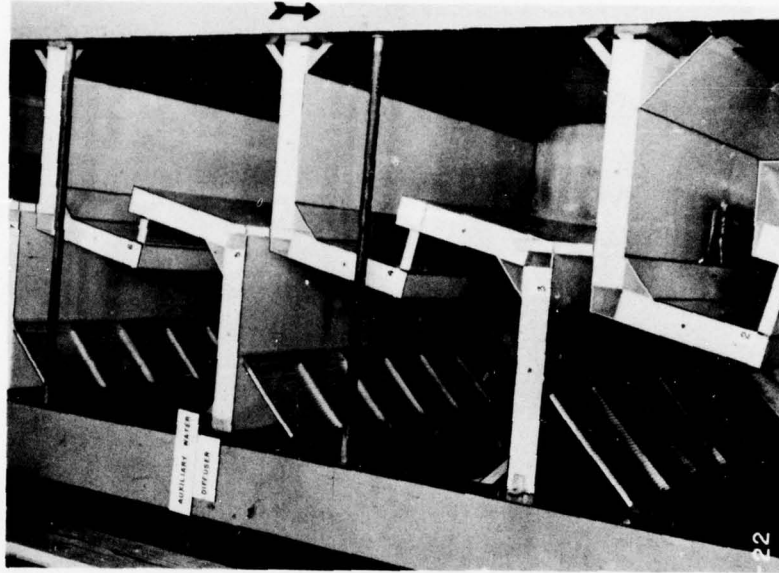

Pools 1 to 6 and auxiliary water diffusers

Photograph 3. Details of plan A fish ladder.

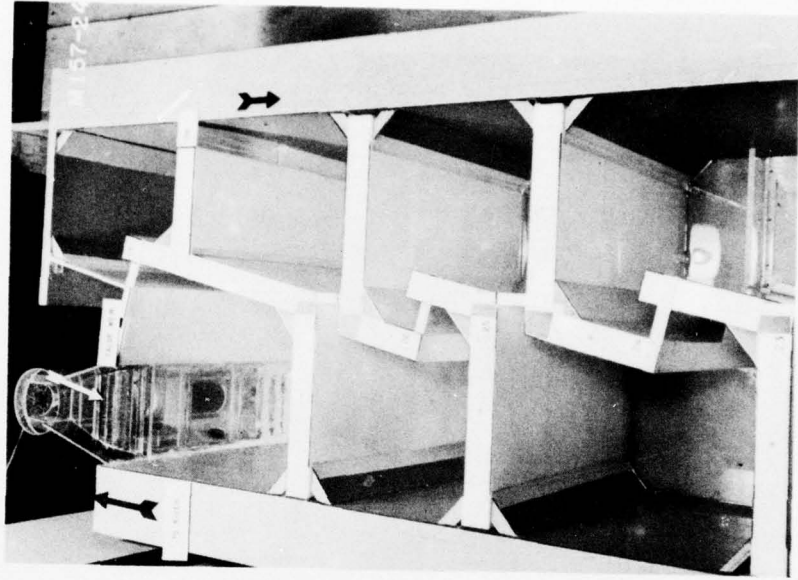

Pools 23 to 29 and false weir

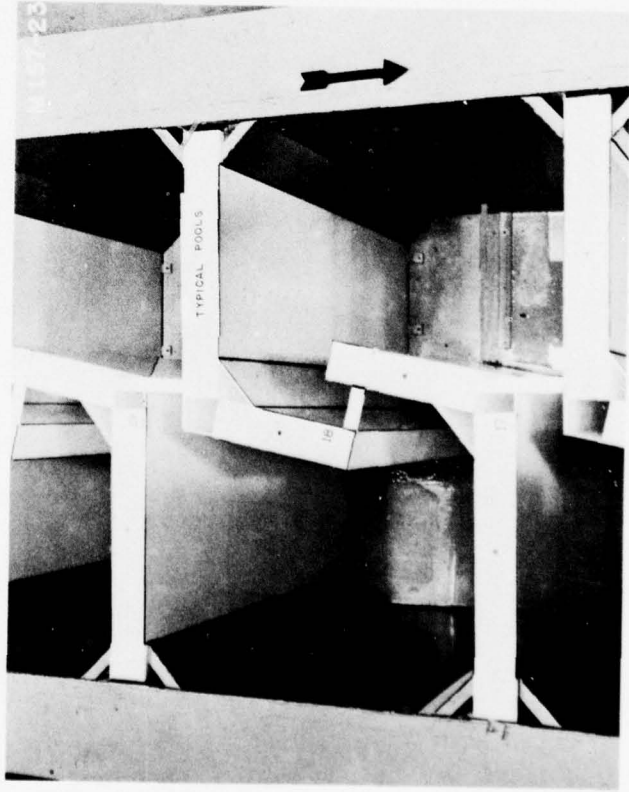

Typical pools (pools 17 and 18)

Photograph 3, continued

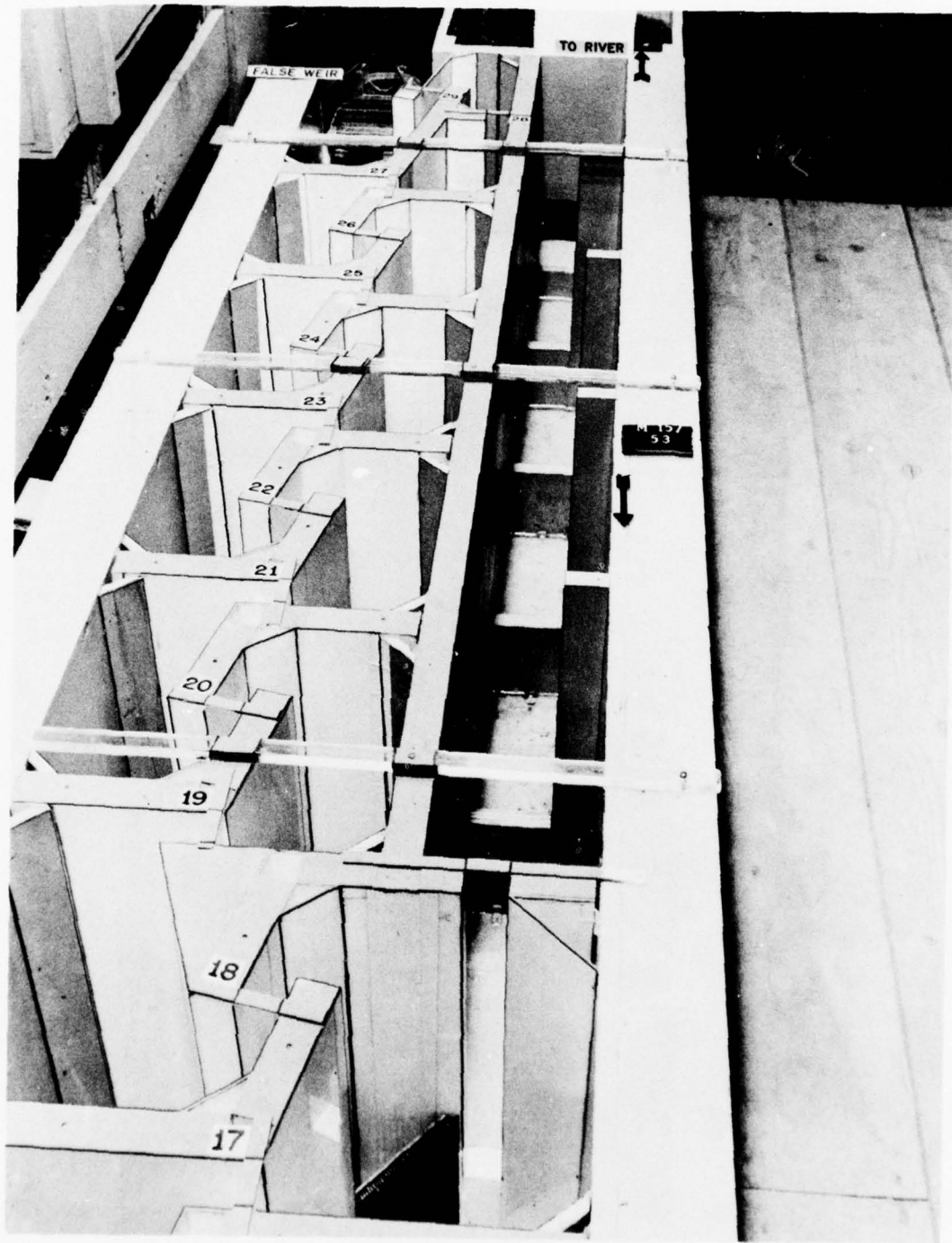

Photograph 4. Plan B fish ladder, pools 17 to 29 and low tide exit.

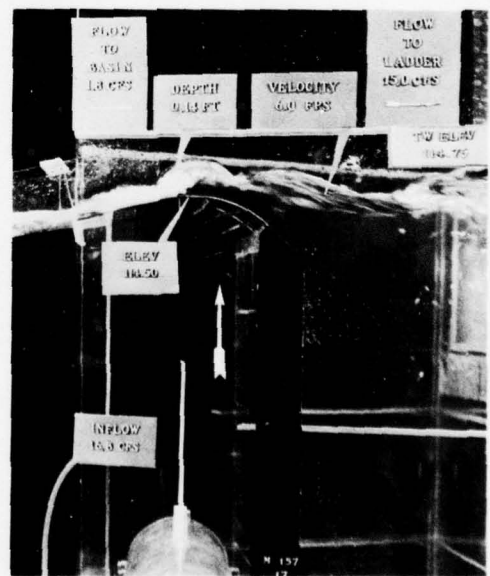
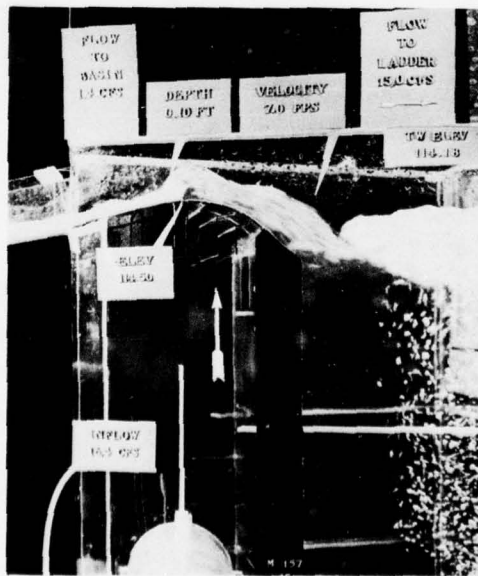
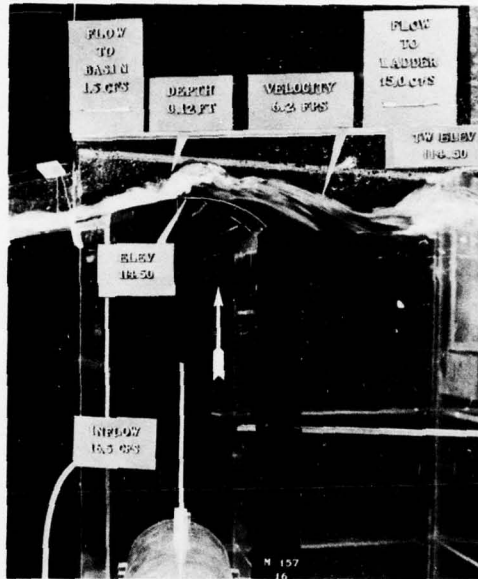

Photograph 5. Flow conditions at false weir.
 Discharge to ladder 15.0 cfs.

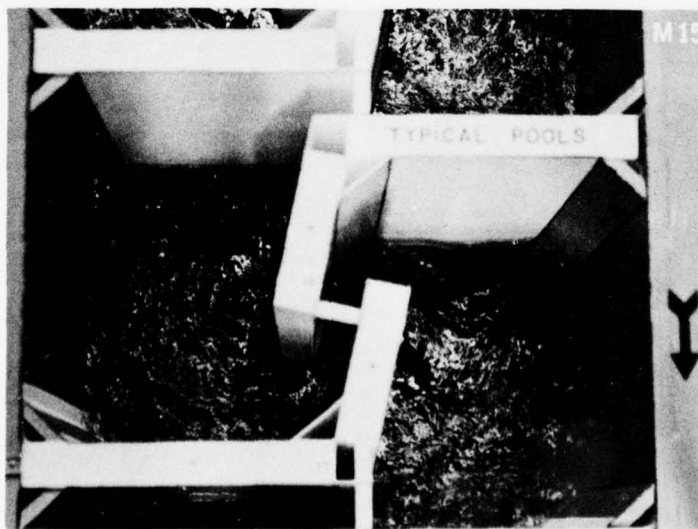
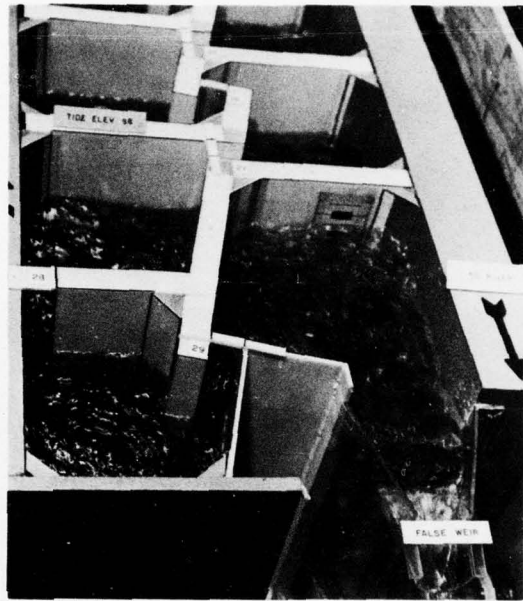
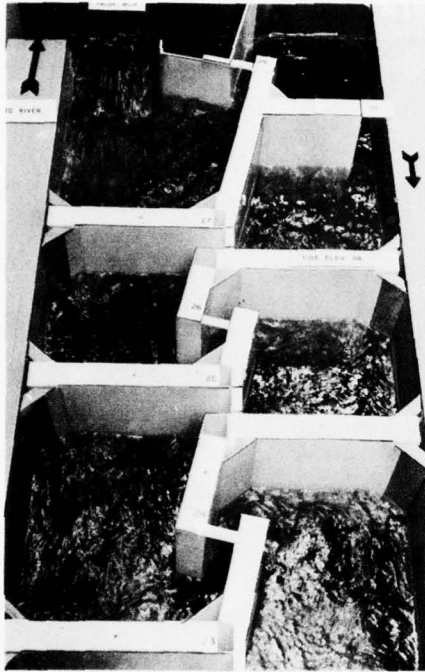

Photograph 6. Flow conditions in plan A fish ladder.
Tide elev 98.0.

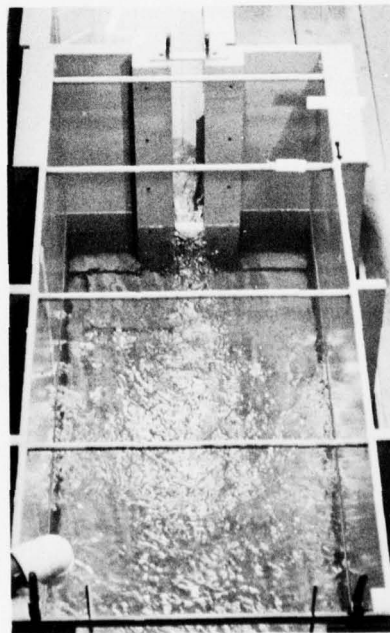
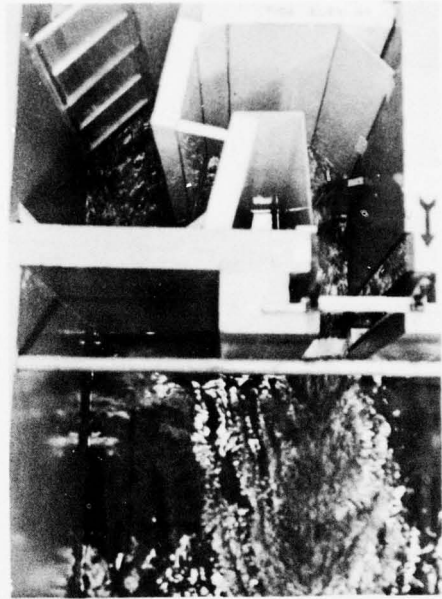
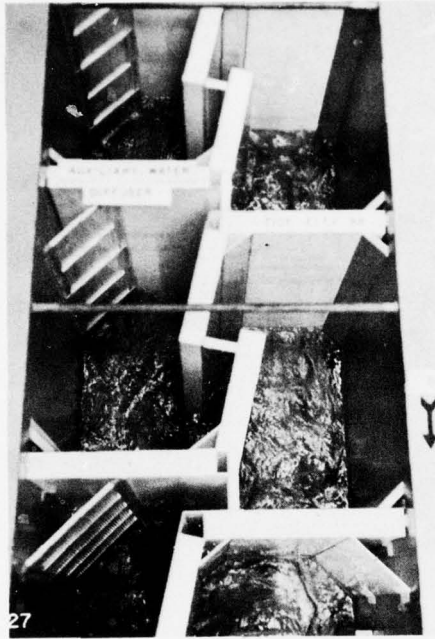

Photograph 6, continued

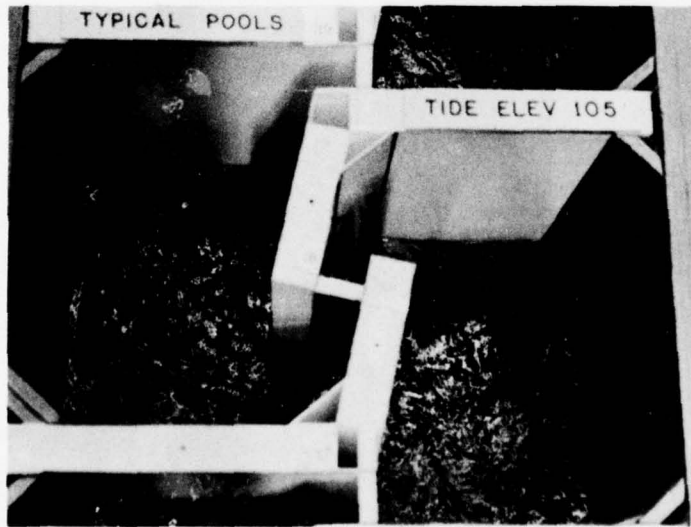
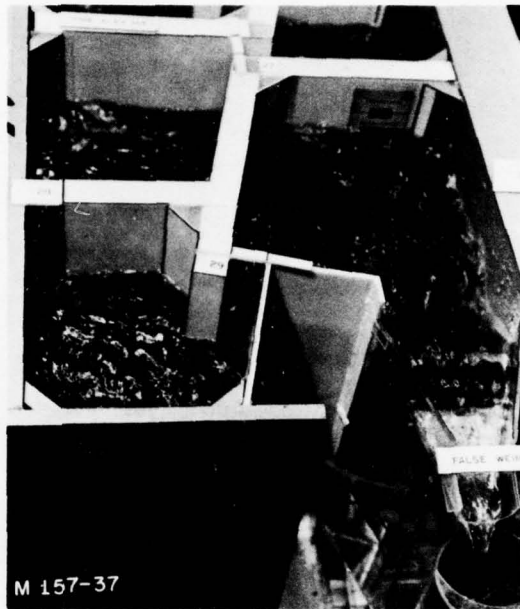
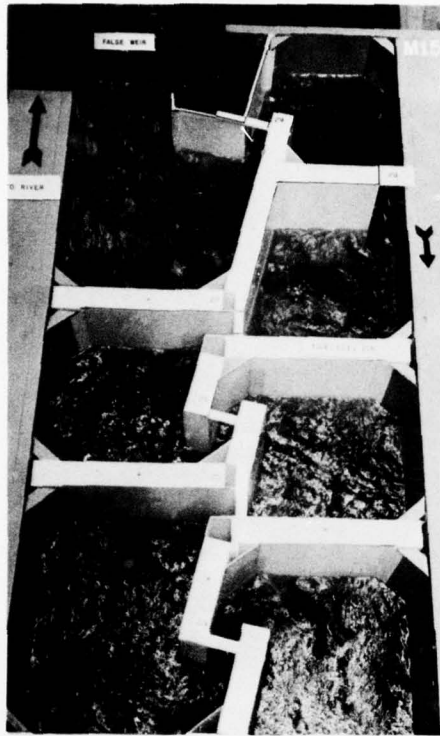

Photograph 7. Flow conditions in plan A fish ladder.
Tide elev 105.0.

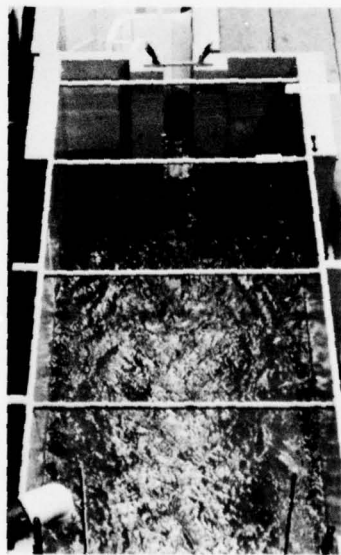
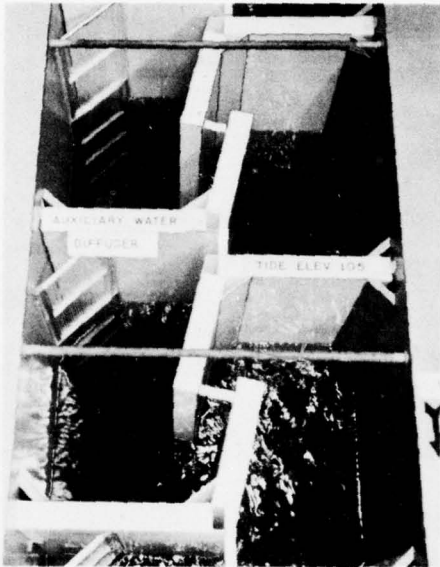

Photograph 7, continued

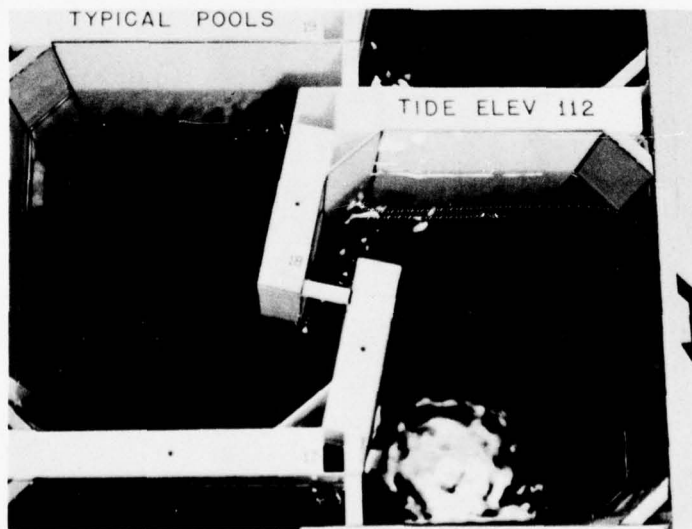
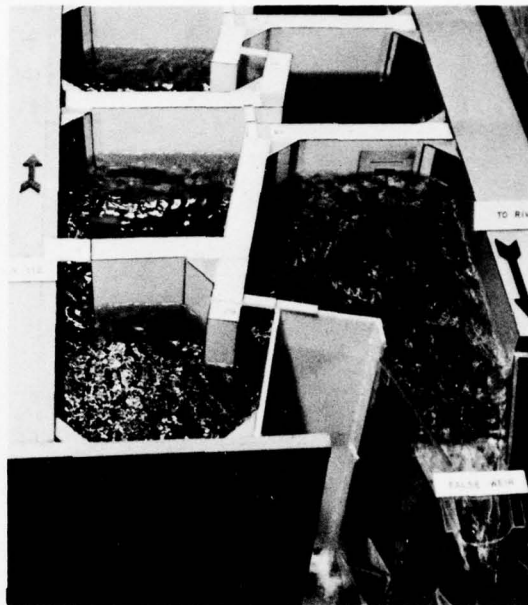
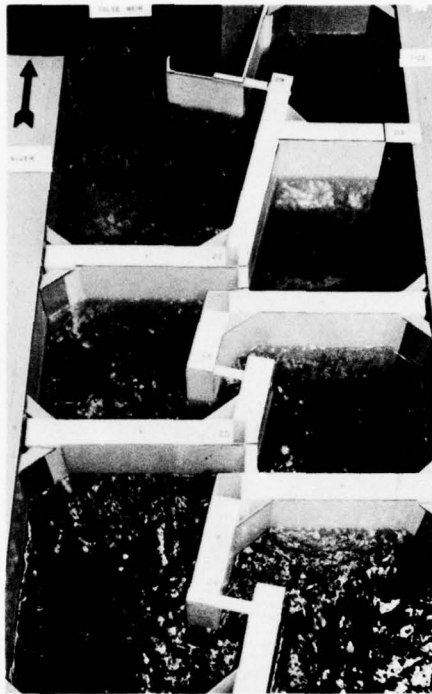

Photograph 8. Flow conditions in plan A fish ladder.
Tide elev 112.0.

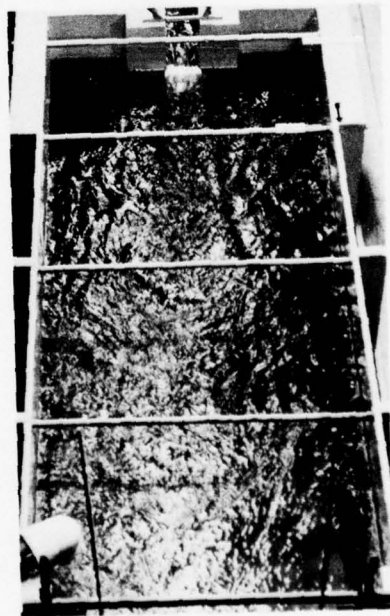
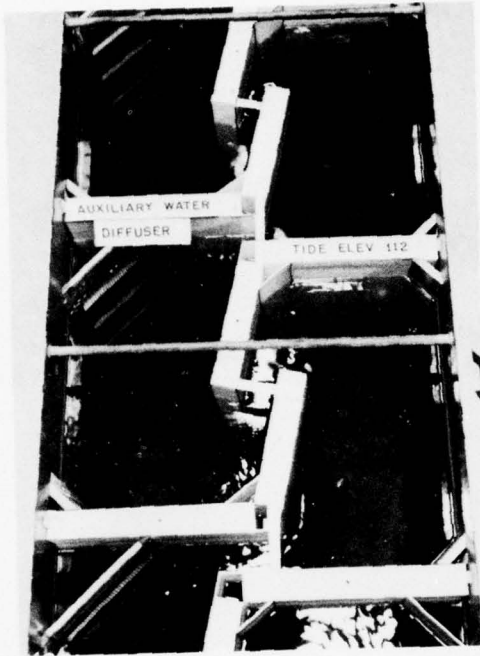

Photograph 8, continued

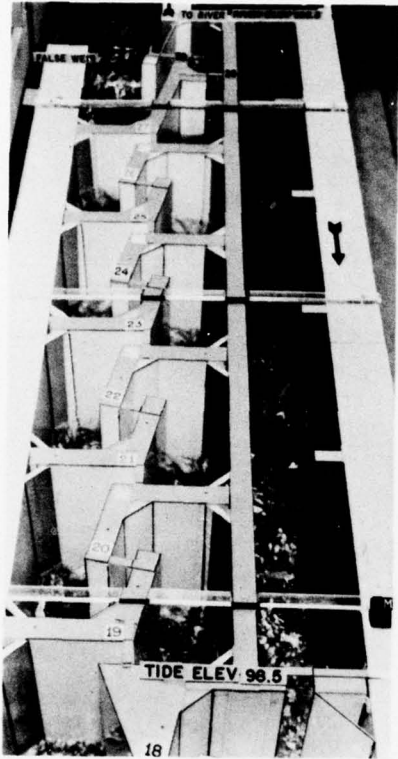

Photograph 9. Flow conditions in plan B fish ladder.
River elev 108.5, tide elev 98.5.

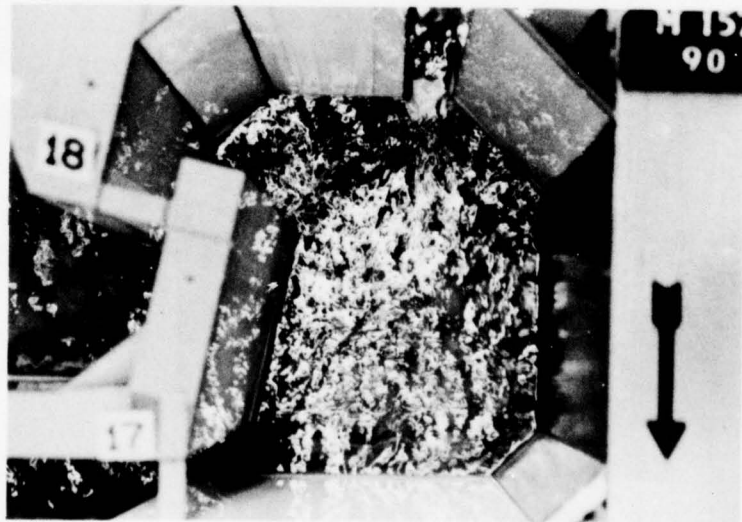
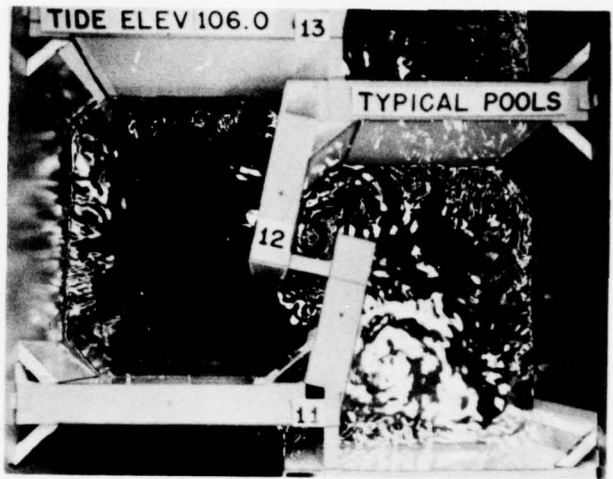
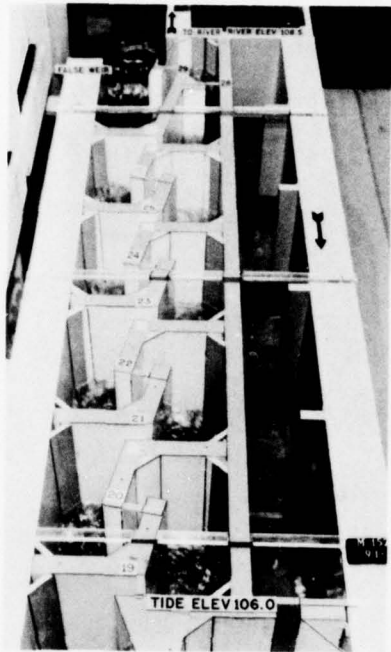

Photograph 10. Flow conditions in plan B fish ladder.
River elev 108.5, tide elev 106.0.

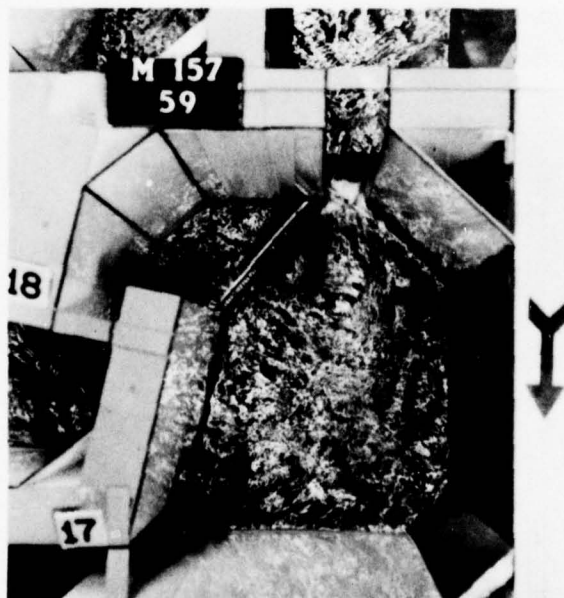
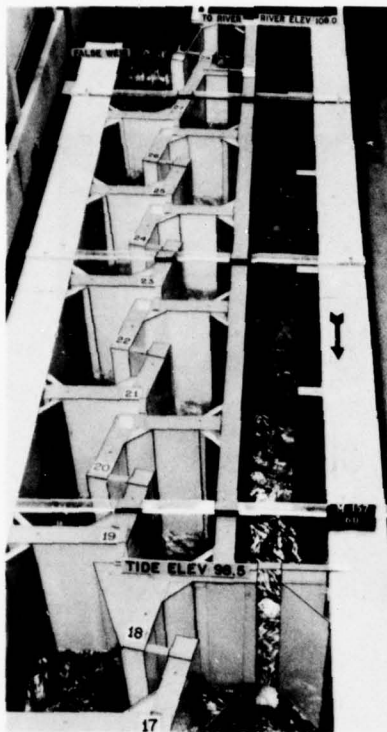

Photograph 11. Flow conditions in plan B fish ladder.
River elev 108.0, tide elev 98.5.

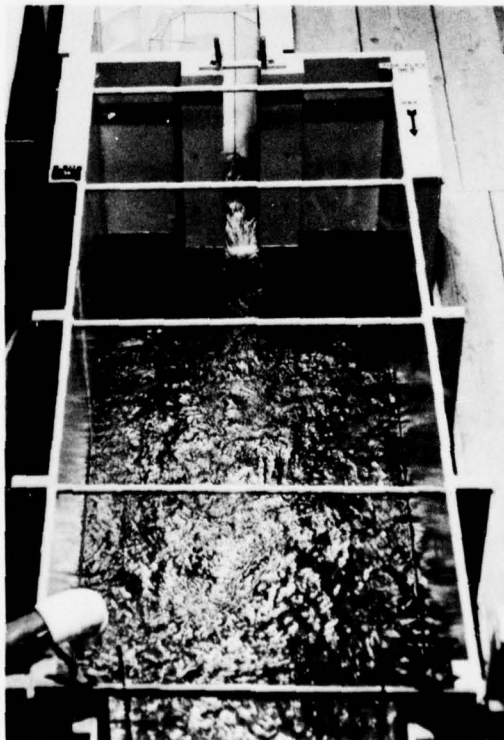
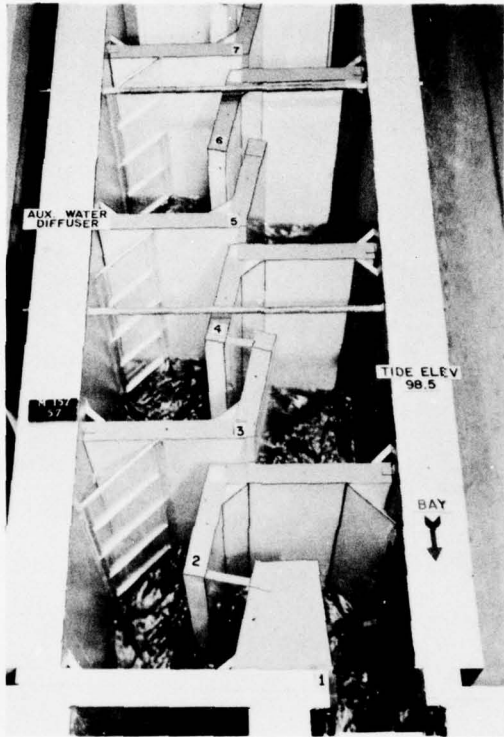

Photograph 11, continued

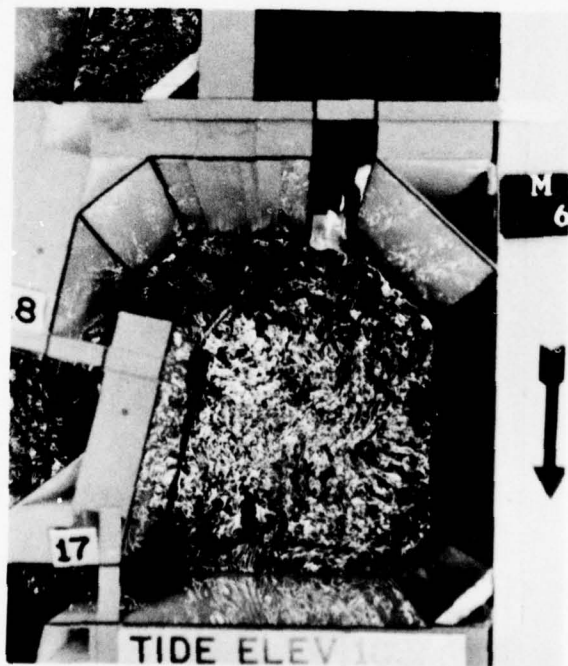
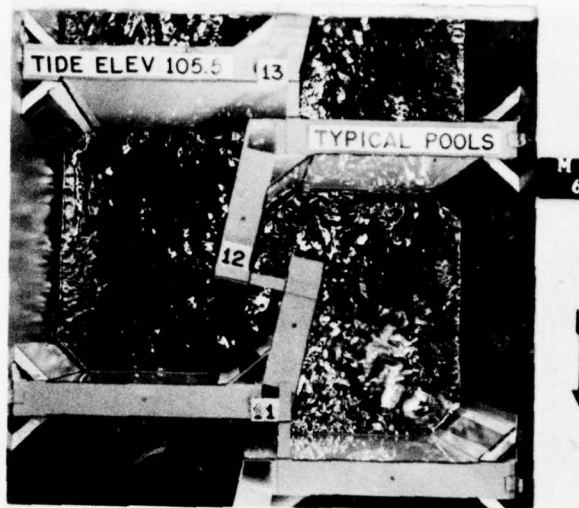
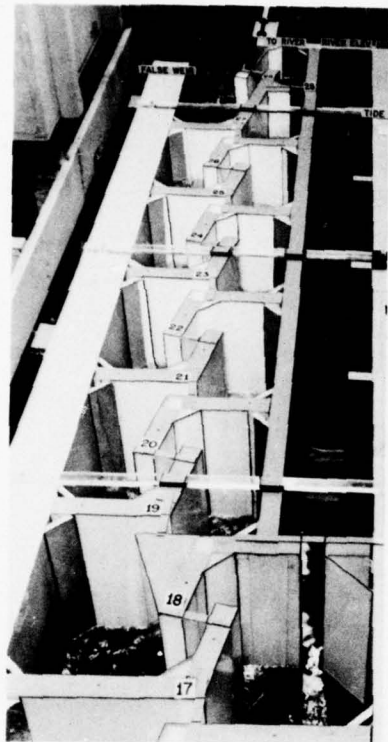

Photograph 12. Flow conditions in plan B fish ladder.
River elev 108.0, tailwater elev 105.5.

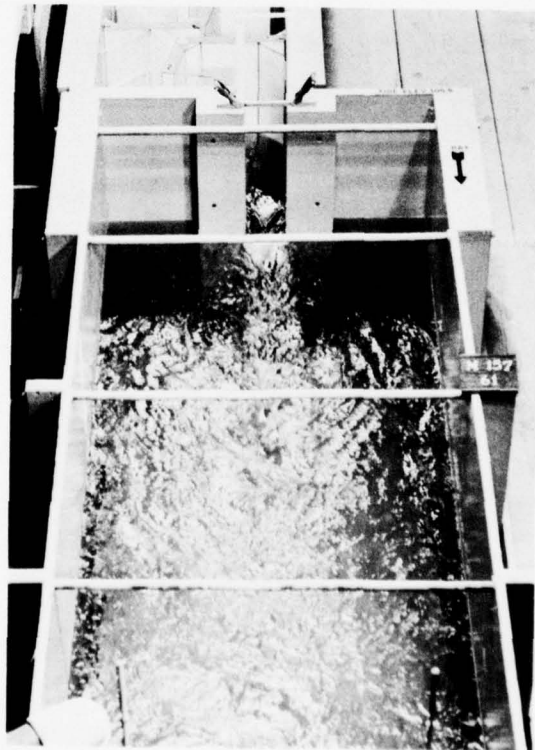
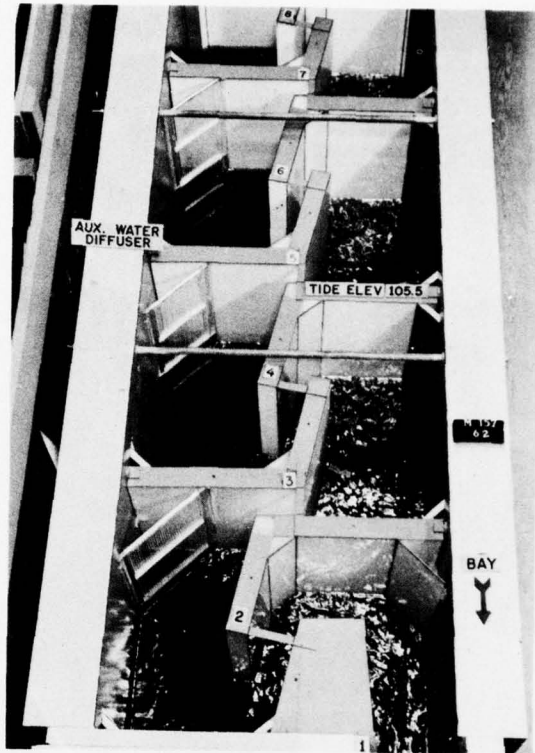

Photograph 12, continued

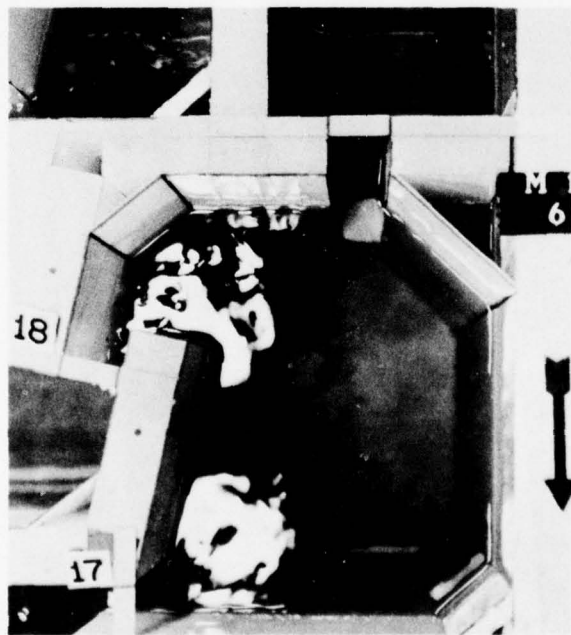
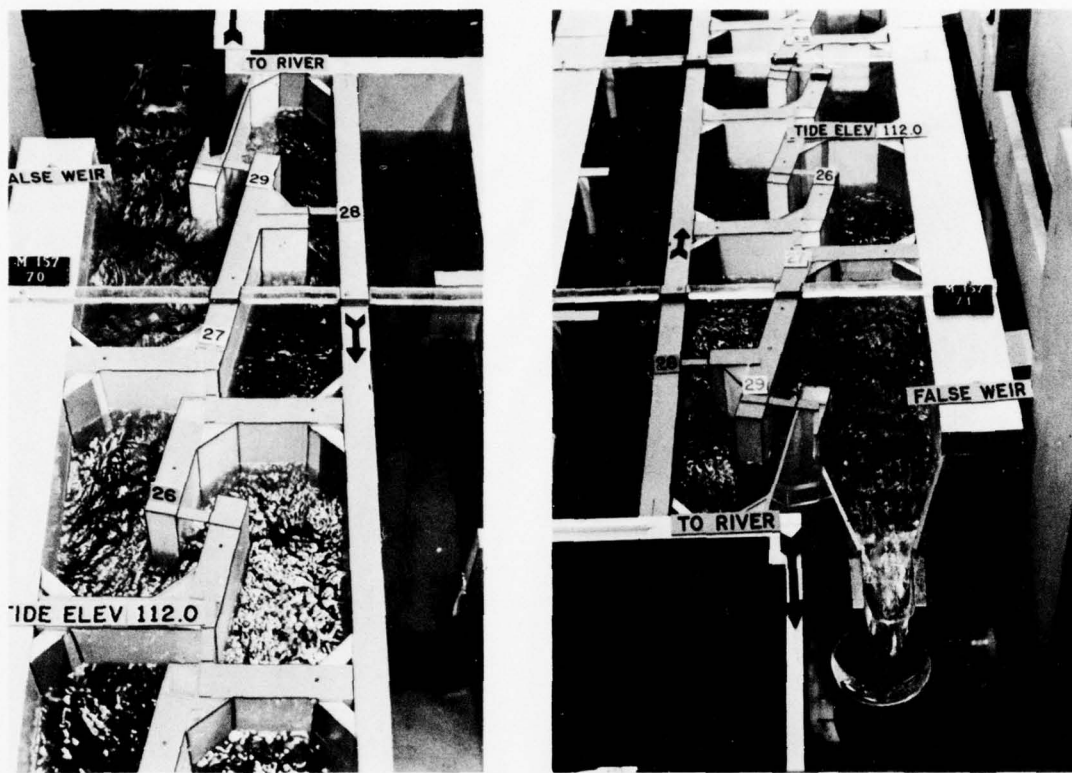

Photograph 13. Flow conditions in plan B fish ladder.
River elev 108.0, tide elev 112.0.

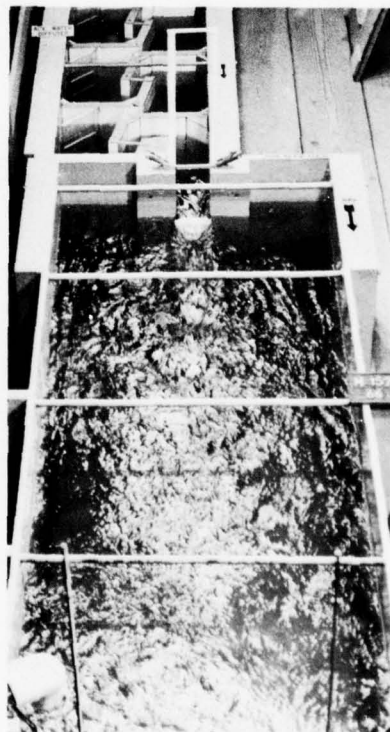
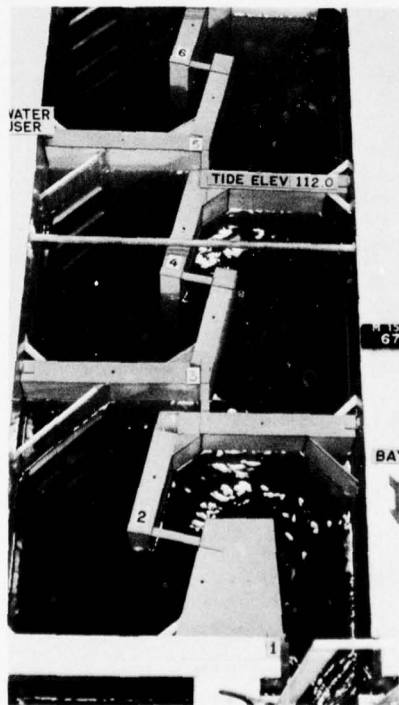
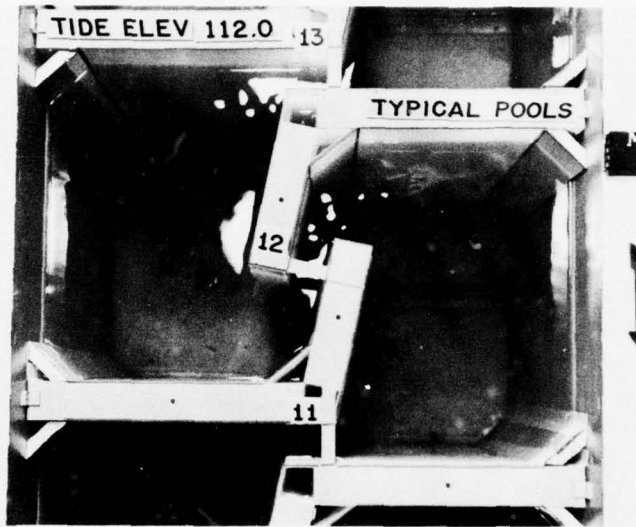

Photograph 13, continued

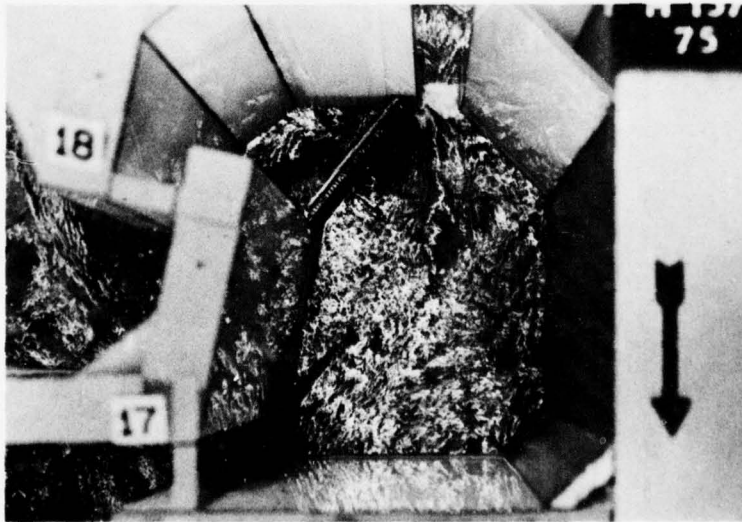
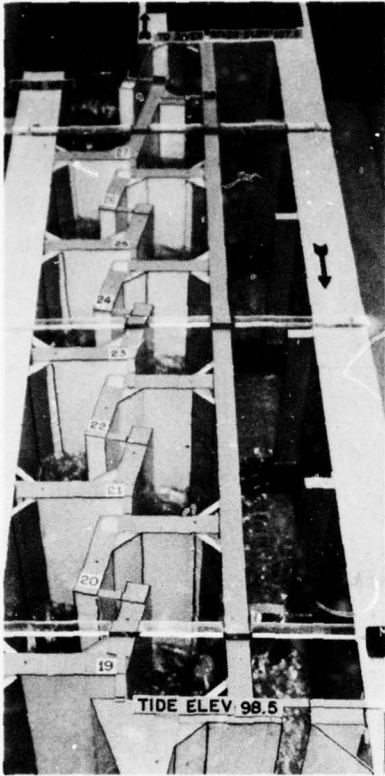

Photograph 14. Flow conditions in plan B fish ladder.
River elev 107.5, tide elev 98.5.

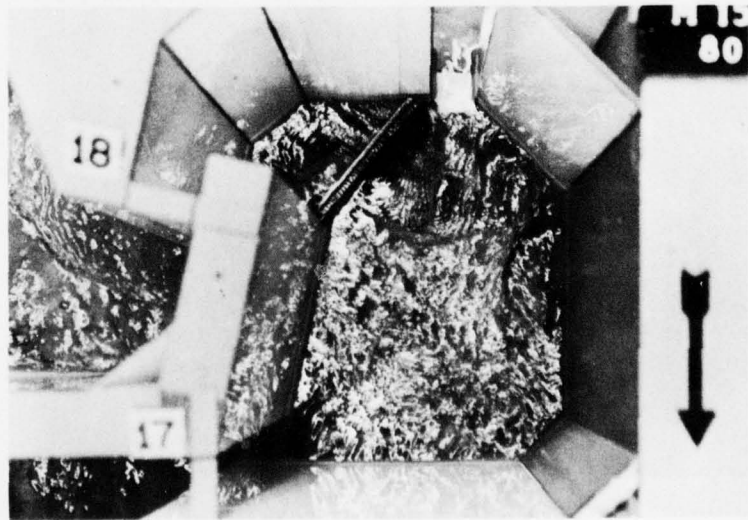
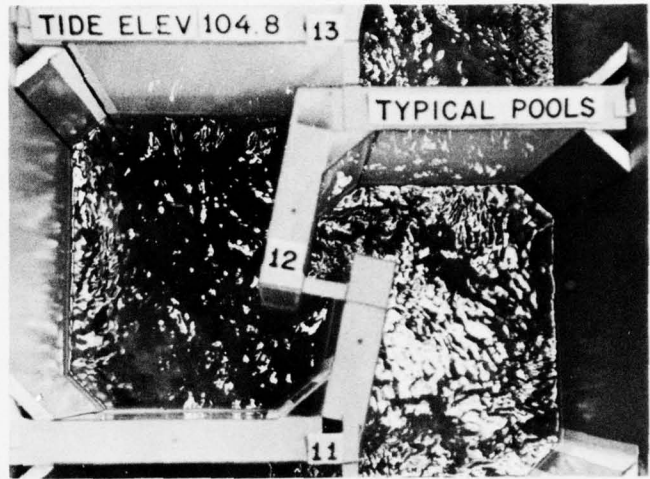
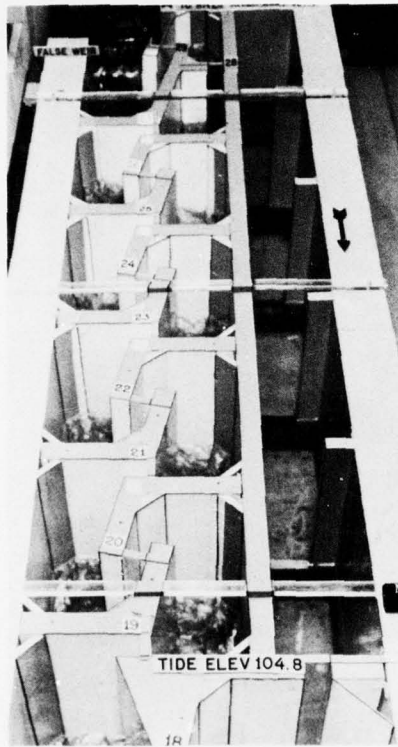

Photograph 15. Flow conditions in plan B fish ladder.
River elev 107.5, tide elev 104.8.

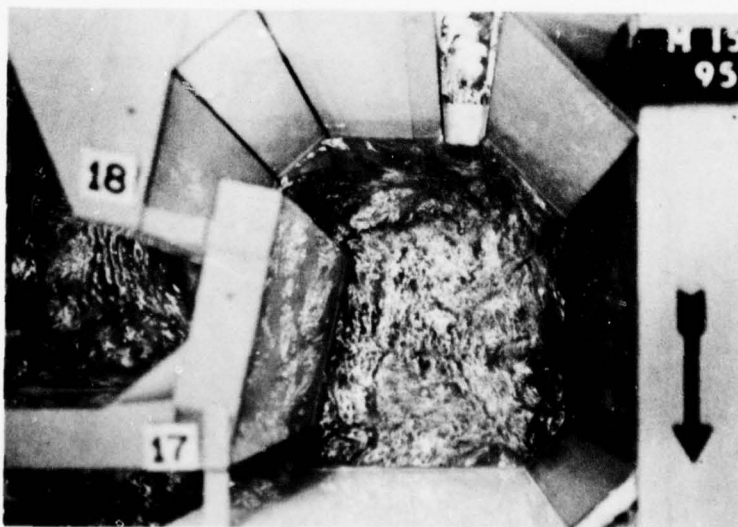
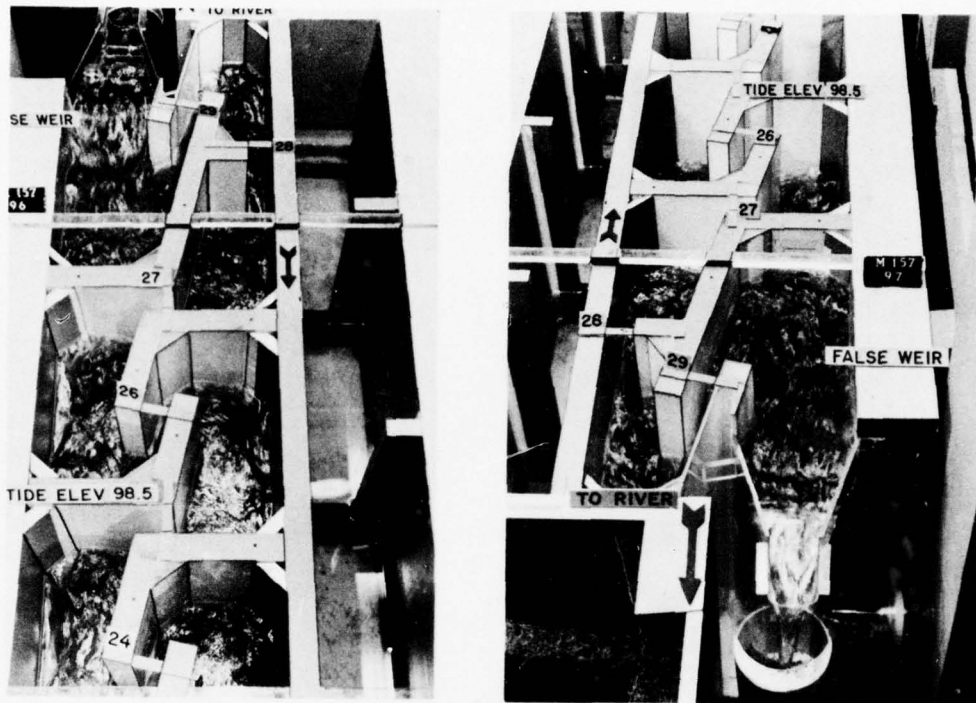

Photograph 16. Flow conditions in plan B fish ladder
 with low tide exit closed and barrier
 in pool 17 removed.
 River elev 108.0, tide elev 98.5.

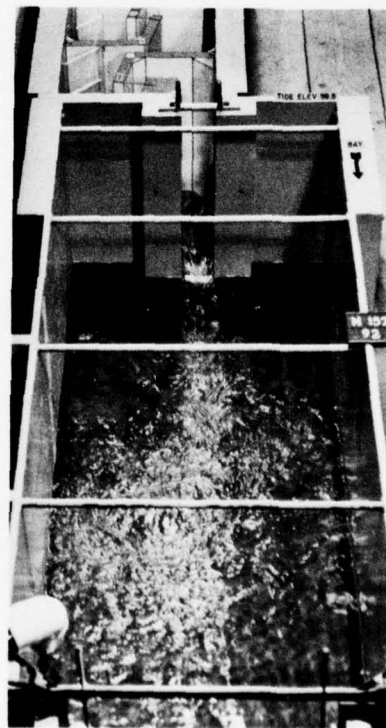
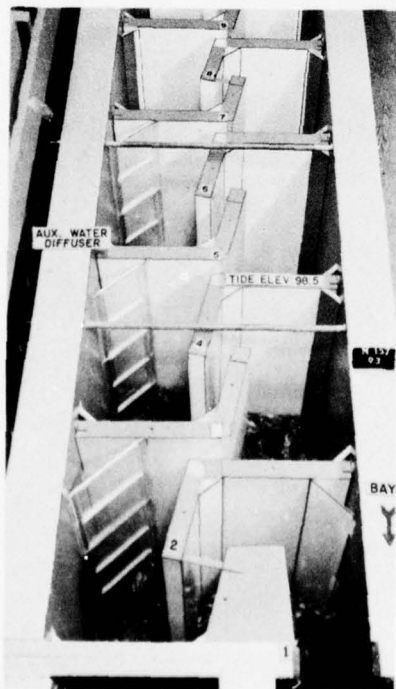
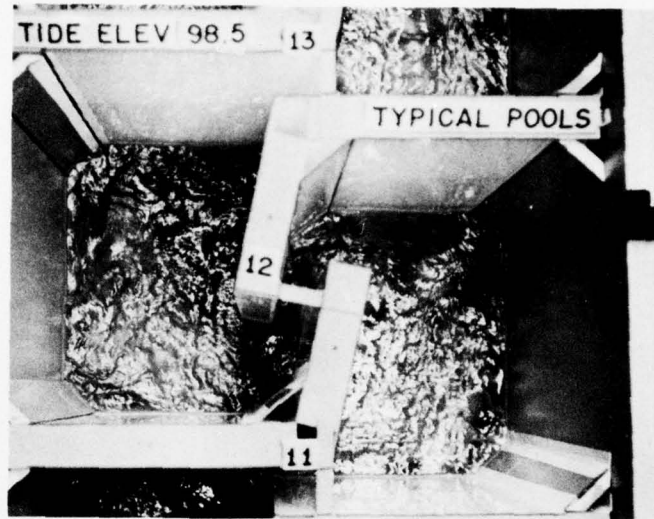

Photograph 16, continued

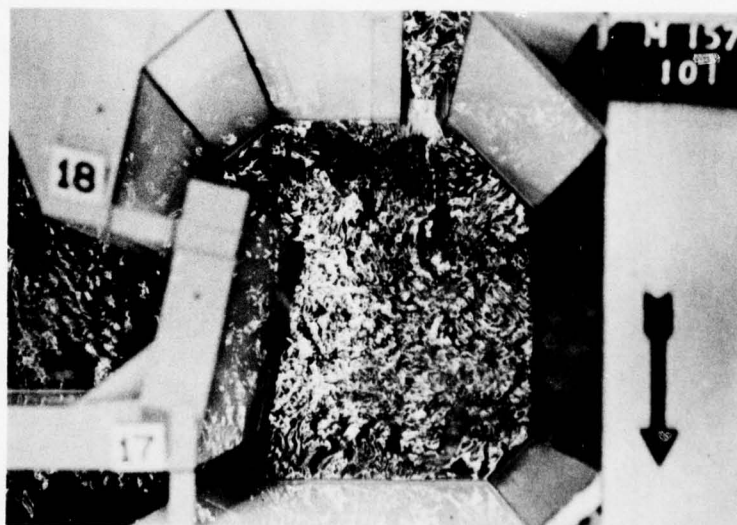
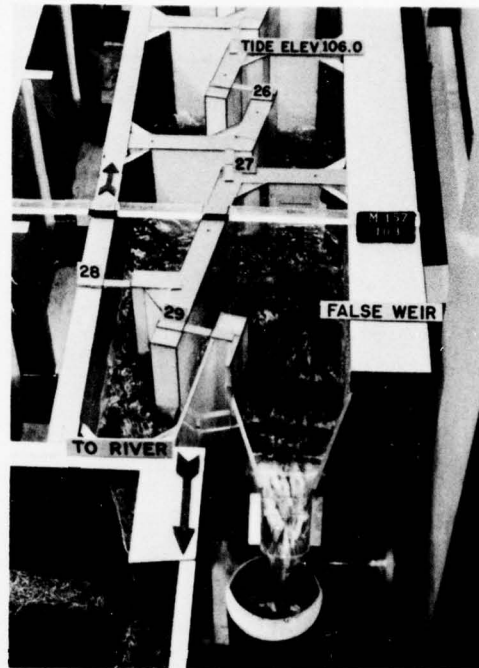
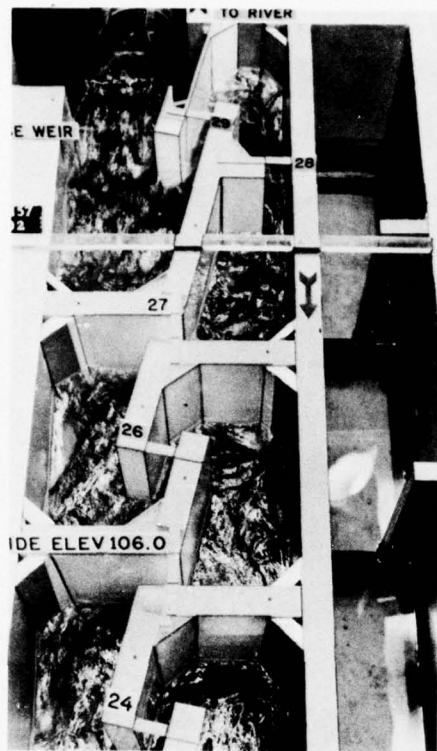

Photograph 17. Flow conditions in plan B fish ladder with low tide exit closed and barrier in pool 17 removed. River elev 108.0, tide elev 106.0.

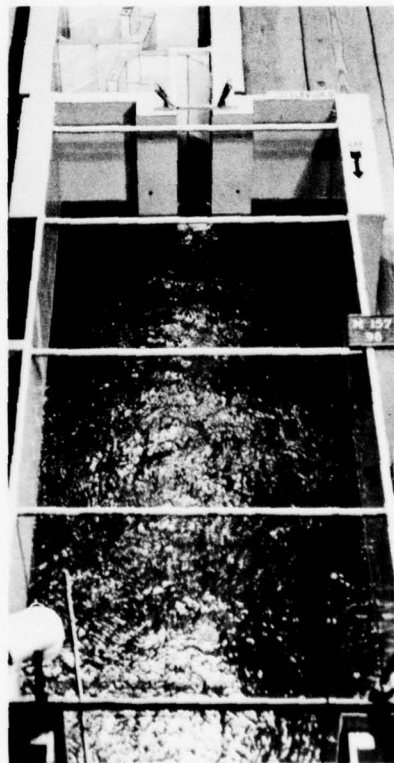
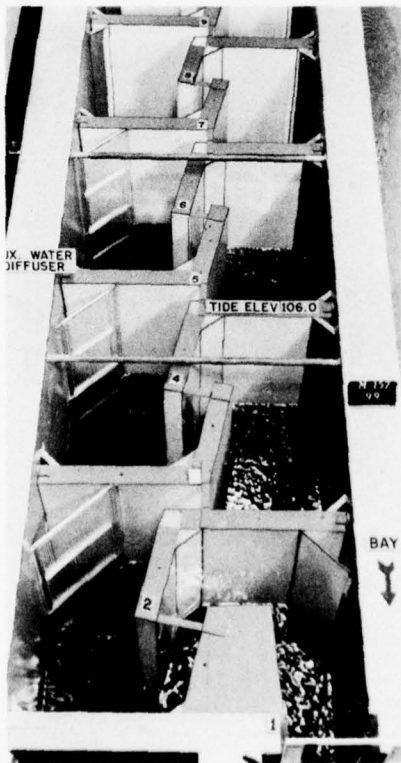

Photograph 17, continued

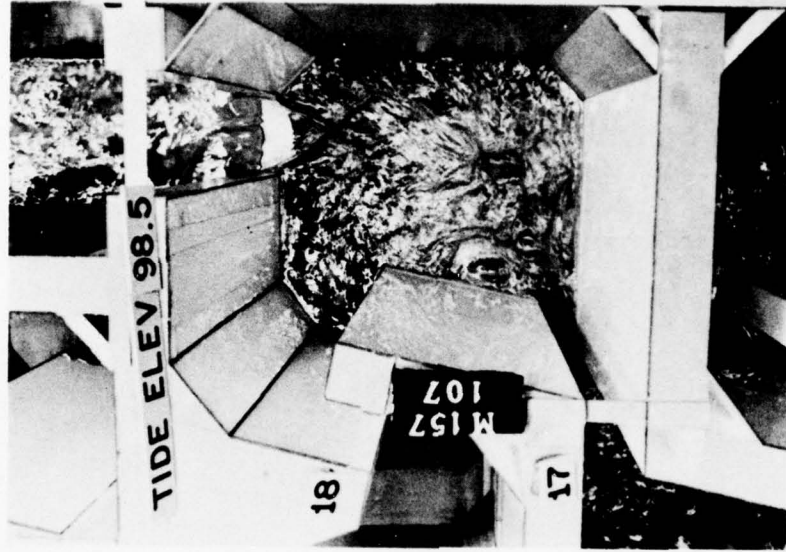
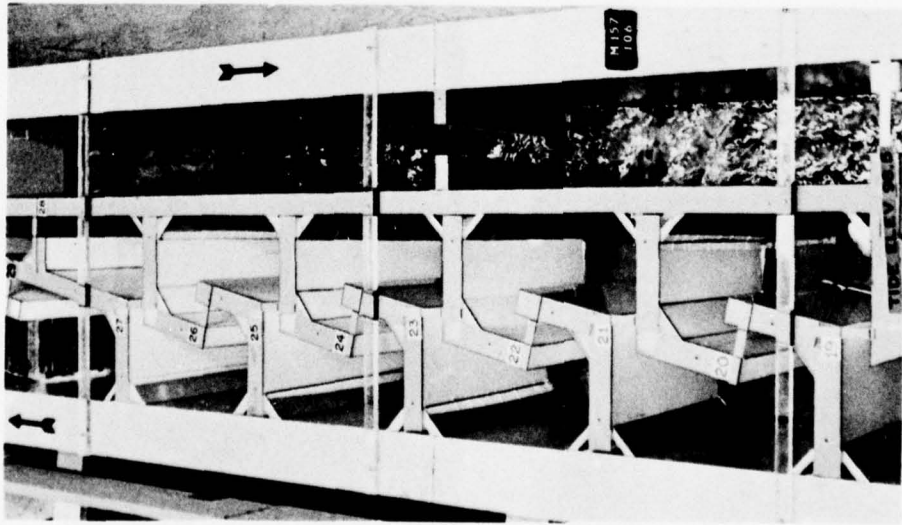

Photograph 18. Flow conditions in plan B fish ladder with modified low tide section. No discharge over false weir. River elev 108.0, tide elev 98.5.

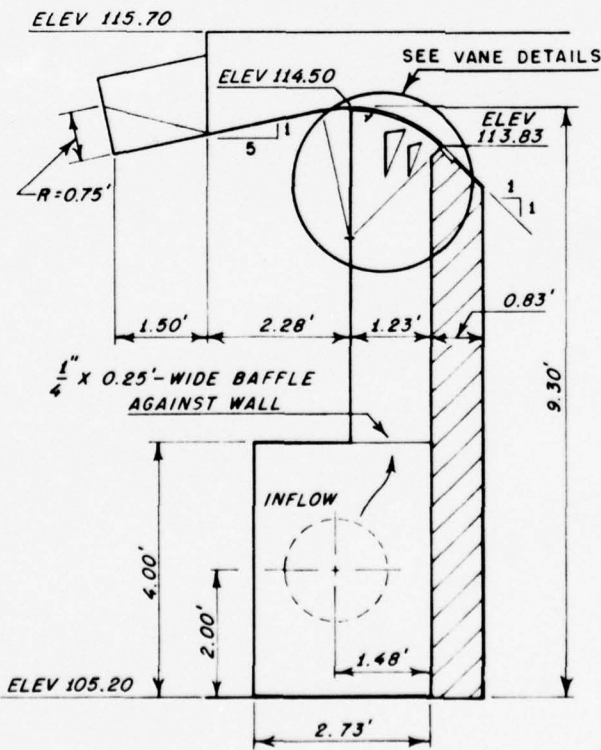
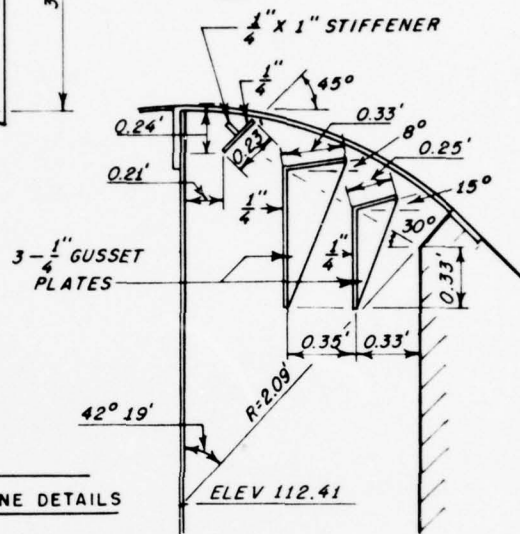
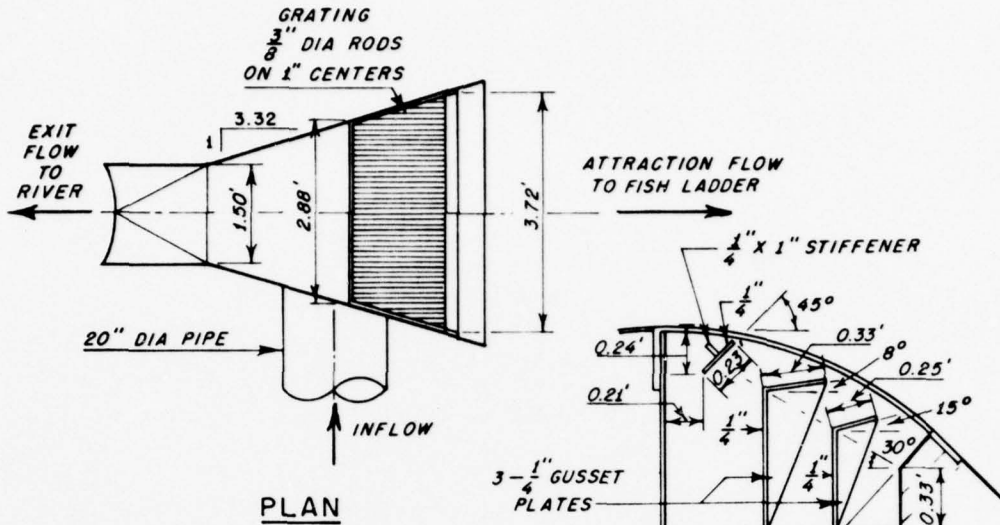

NOTE

ELEVATIONS SHOWN FOR PLAN A FISH LADDER WERE LOWERED 0.2 FT IN PLAN B.

FALSE WEIR

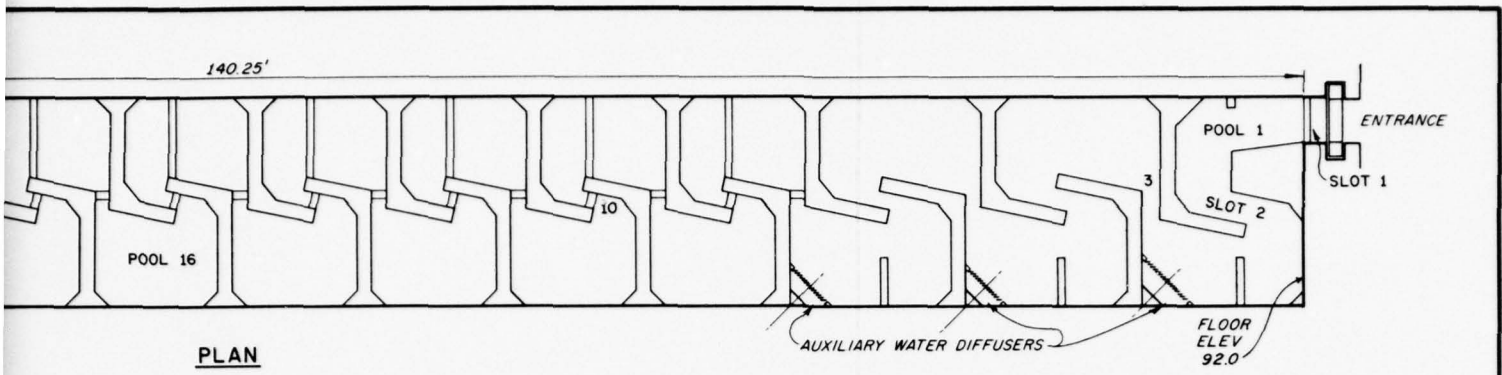

PLAN

SILL SCHEDULE

SLOT NO.	SILL ELEV.
1	96.000
2	NO SILL
3	
4	
5	
6	NO SILL
7	97.476
8	98.484
9	98.724
10	99.844
11	100.004
12	100.996
13	101.348
14	101.964
15	102.500
16	103.556
17	103.700
18	104.836
19	105.220
20	106.252
21	106.980
22	107.644
23	108.644
24	108.396
25	108.964
26	107.364
27	108.436
28	109.996
29	109.556

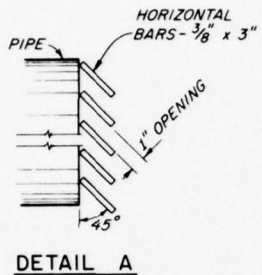
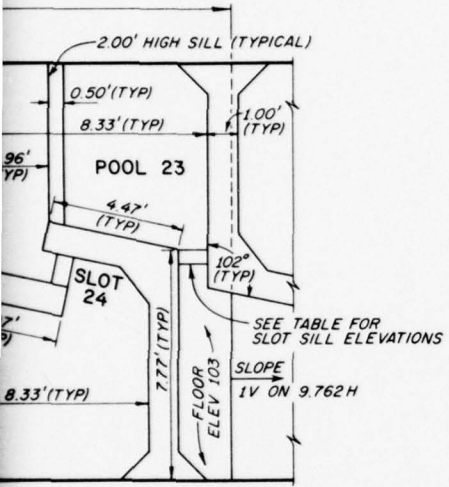

DETAIL A

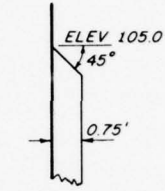

DETAIL B

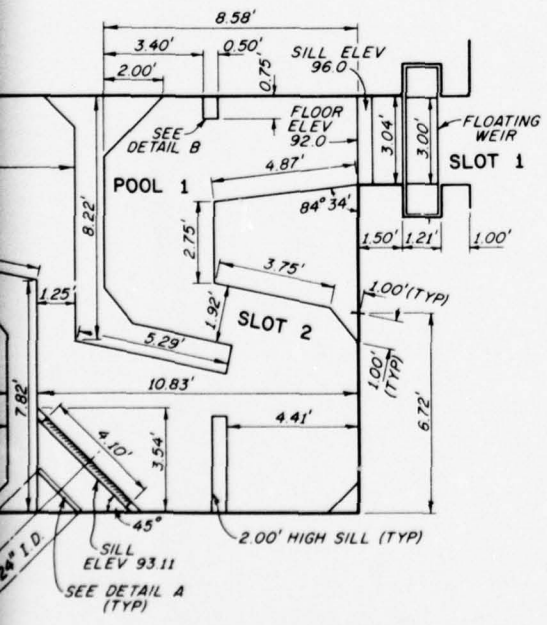

FISH LADDER DETAILS
PLAN A

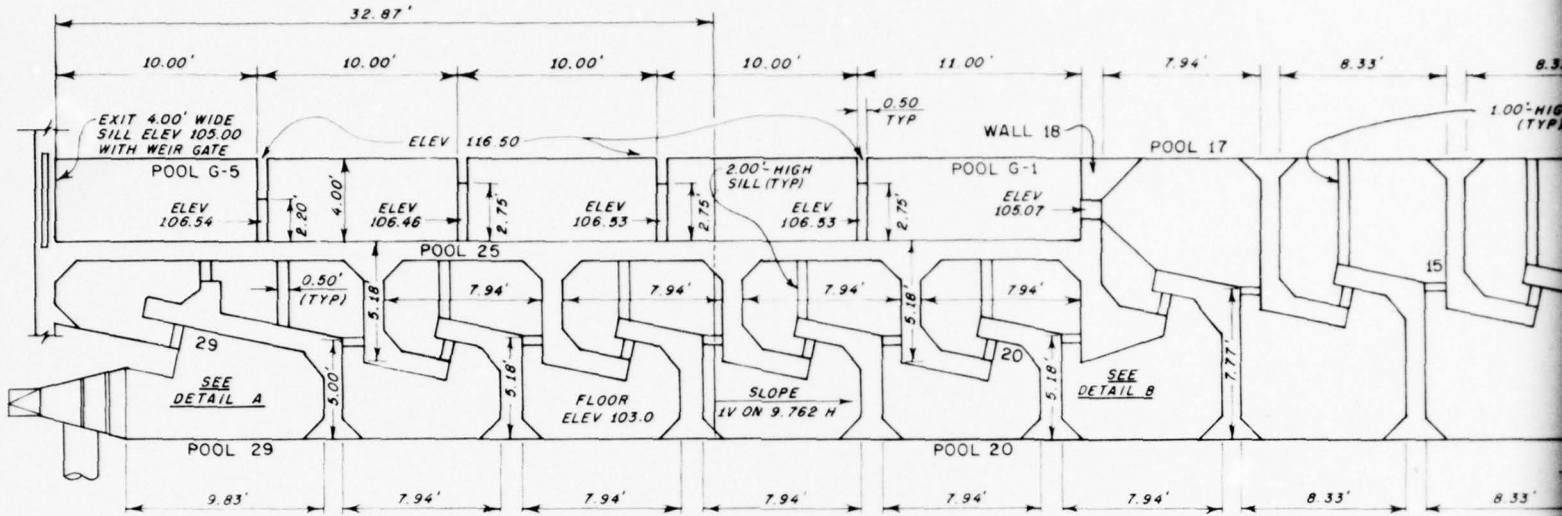

PLAN

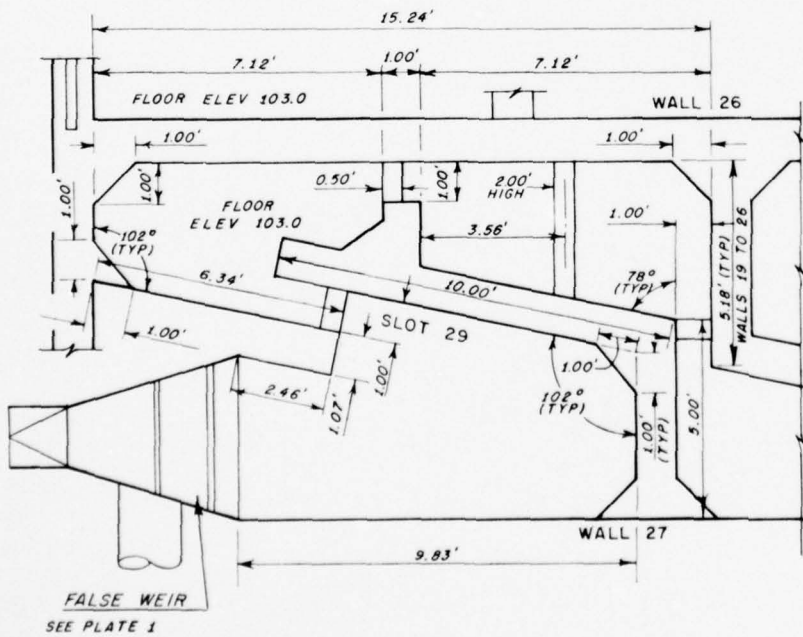

DETAIL A

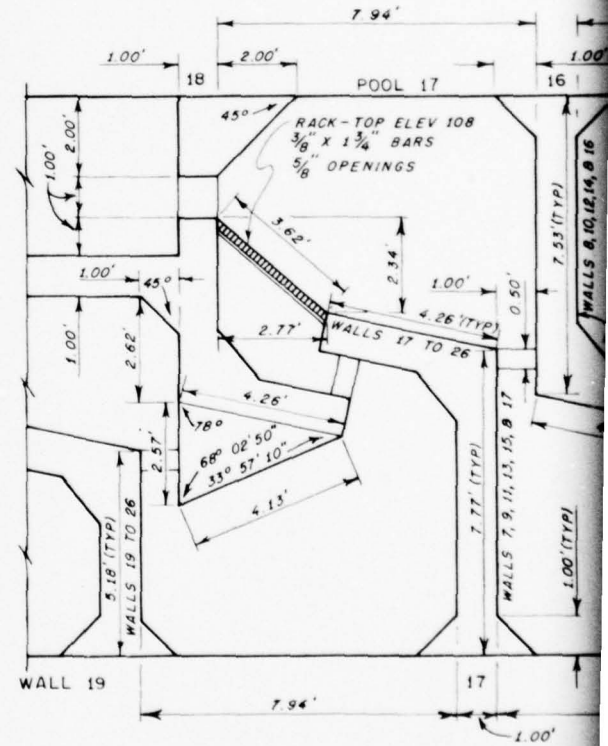

DETAIL B

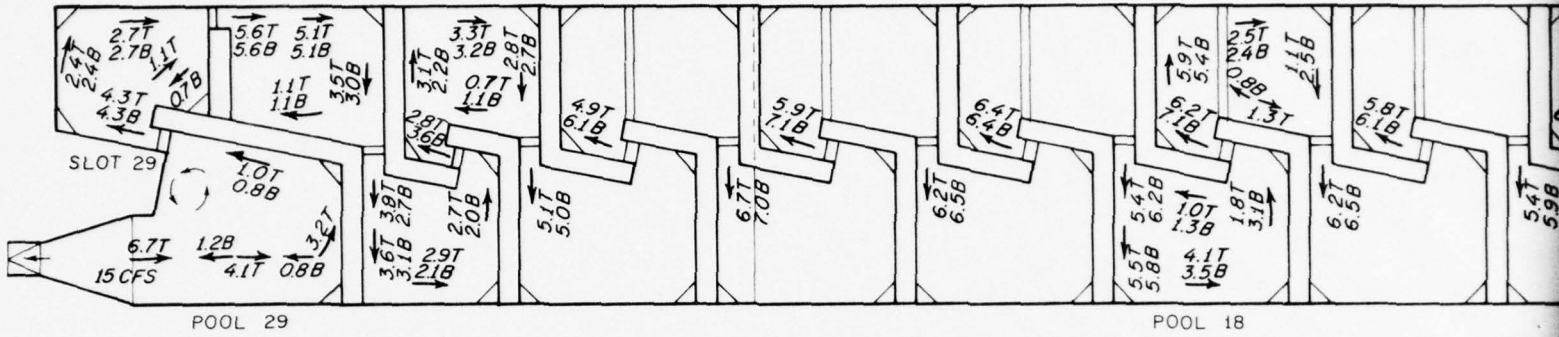

TIDE ELEV.

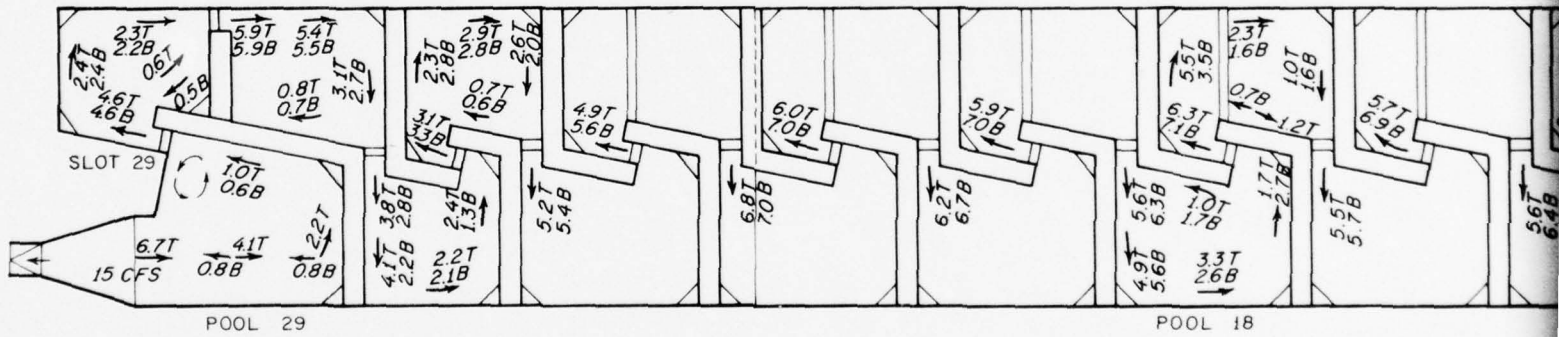

TIDE ELEV.

LEGEND

- 2.4
← VELOCITIES IN FPS
- T 1-FT DEPTH
- B 7-FT DEPTH OR 1FT ABOVE
INVERT OR SILL OF UPSTREAM SLOT
- * 1 FT ABOVE SILL.

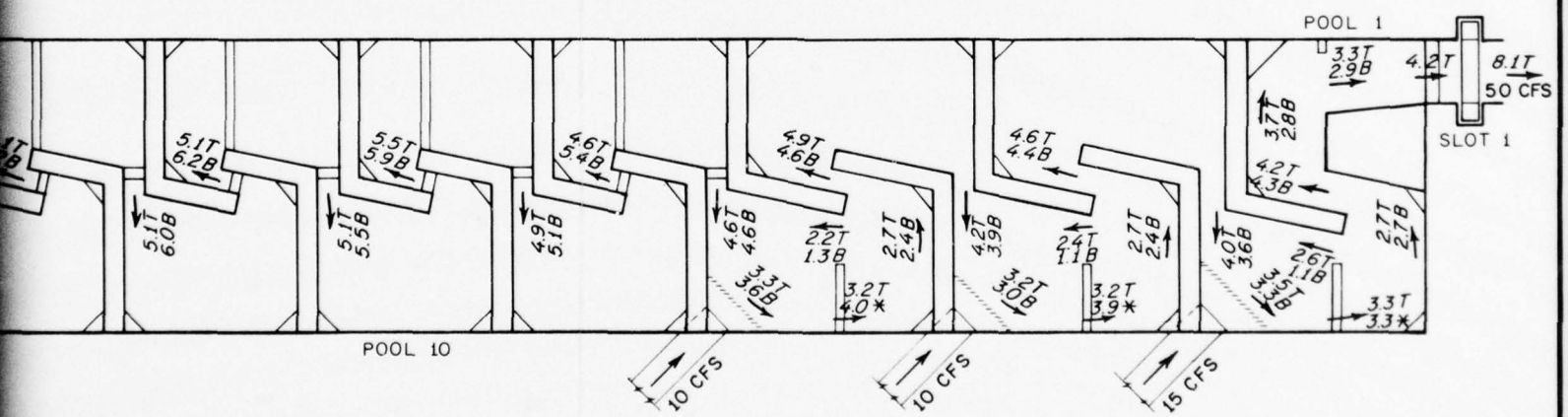
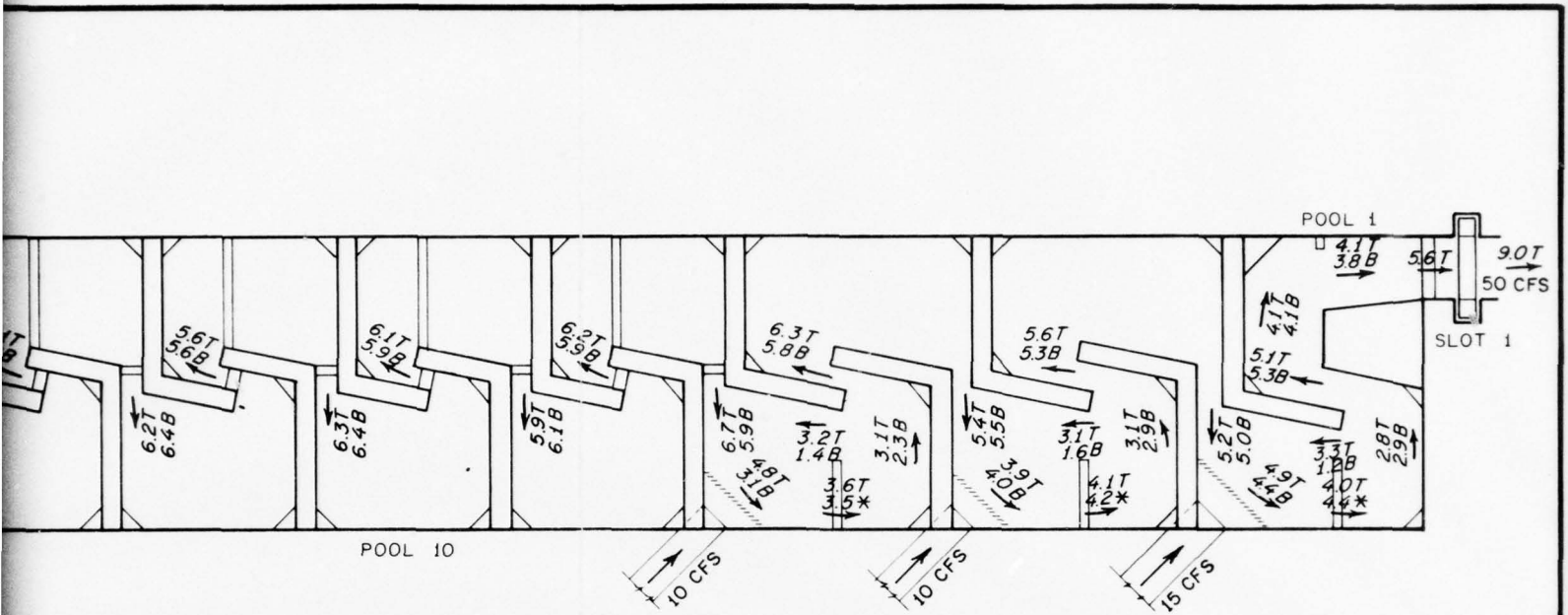

VELOCITIES
 PLAN A FISH LADDER
 TIDE ELEVATIONS 98.0 AND 100.0

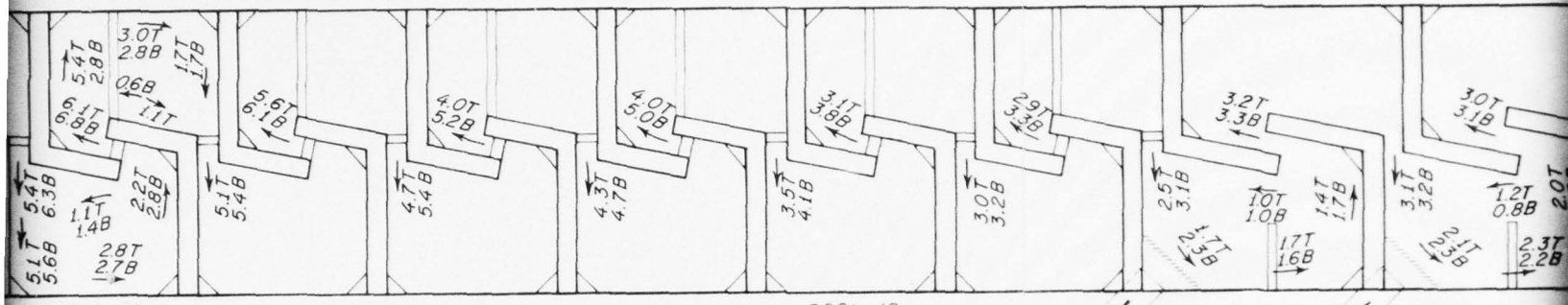

POOL 18

POOL 10

TIDE ELEVATION 103.0

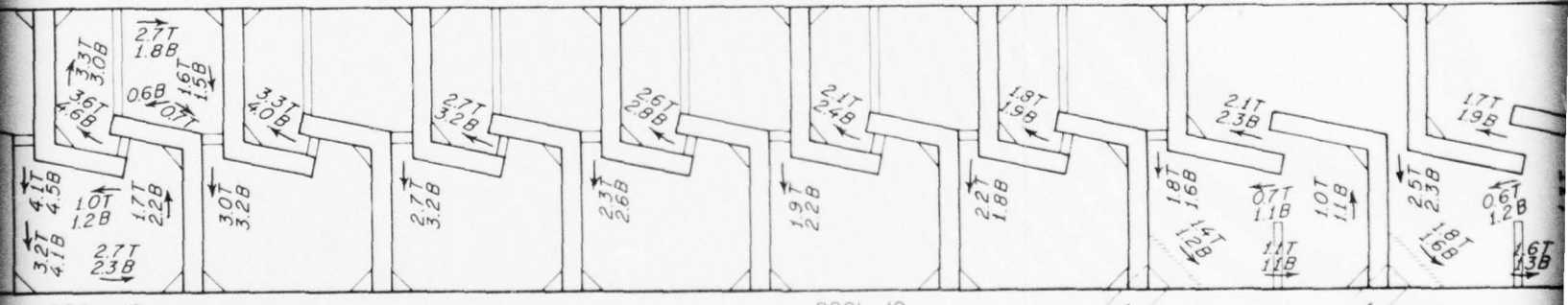

POOL 18

POOL 10

TIDE ELEVATION 107.0

A

P
TIDE

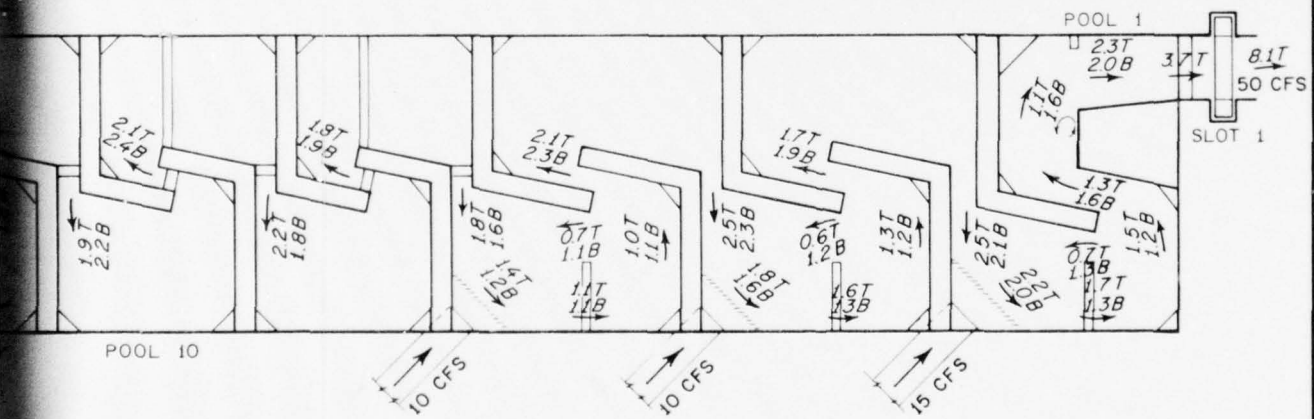
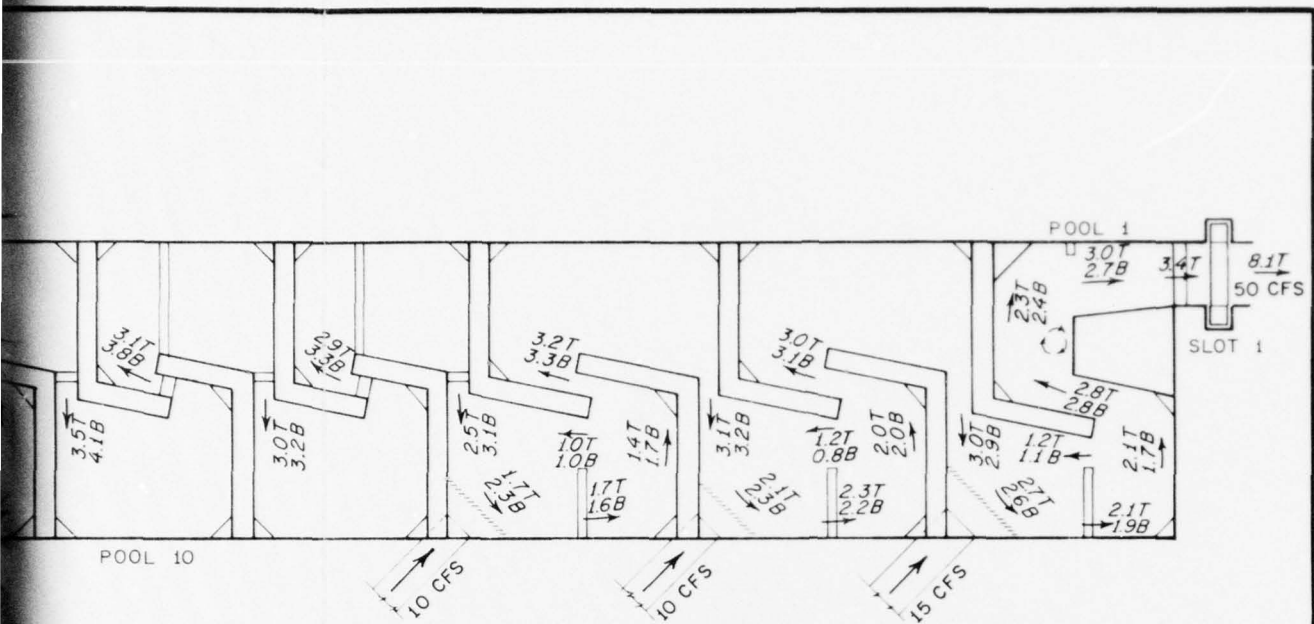

VELOCITIES

PLAN A FISH LADDER

TIDE ELEVATIONS 103.0 AND 107.0

3

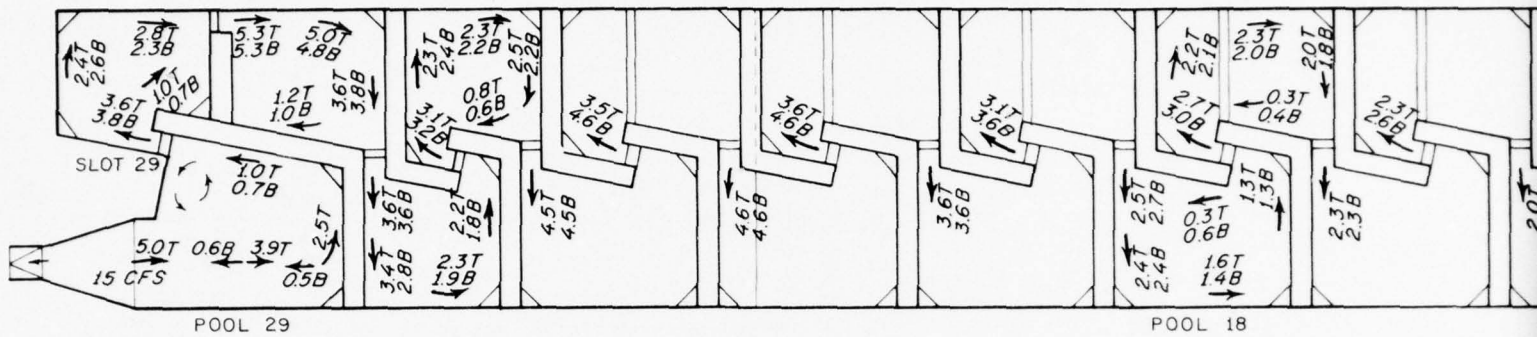

POOL 29

POOL 18

TIDE ELE

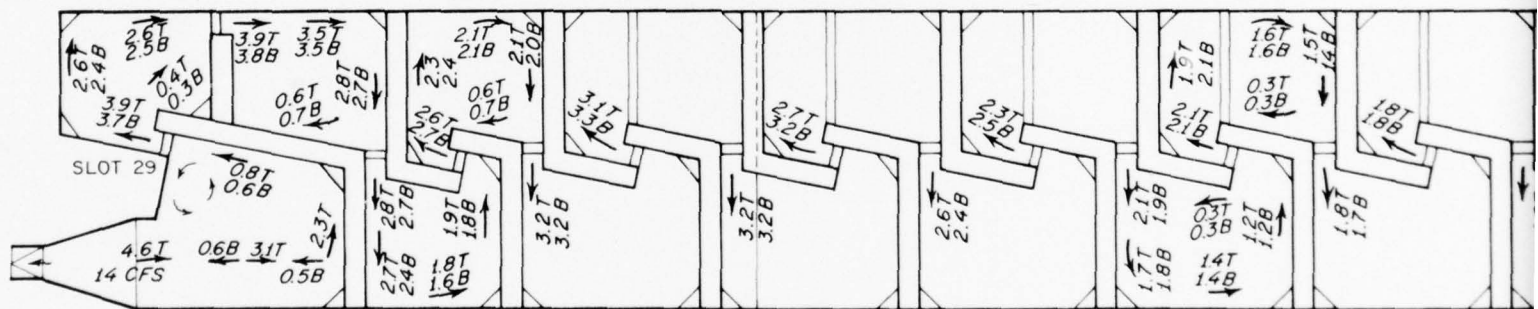

POOL 29

POOL 18

TIDE EL

LEGEND

- ← 2.6 VELOCITIES IN FPS
- T 1-FT DEPTH
- B 7-FT DEPTH OR 1 FT ABOVE
INVERT OR SILL OF UPSTREAM SLOT

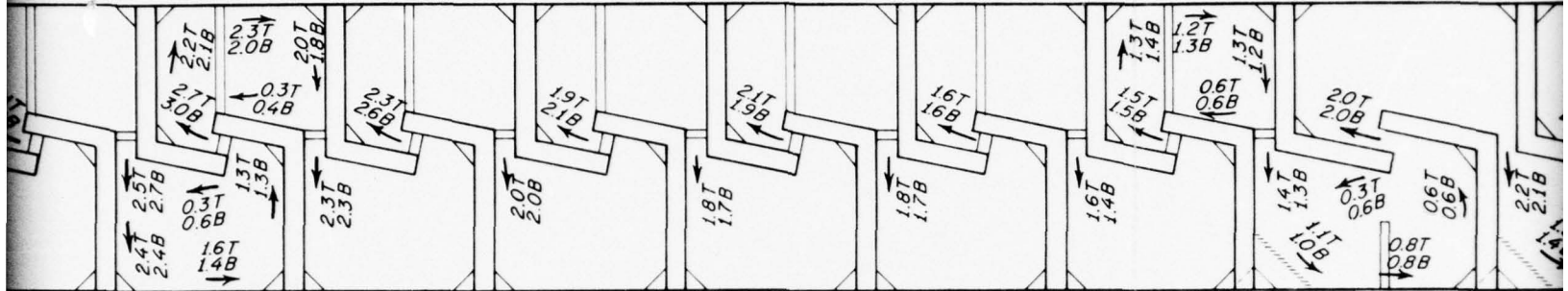

POOL 18

POOL 10

TIDE ELEVATION 110.0

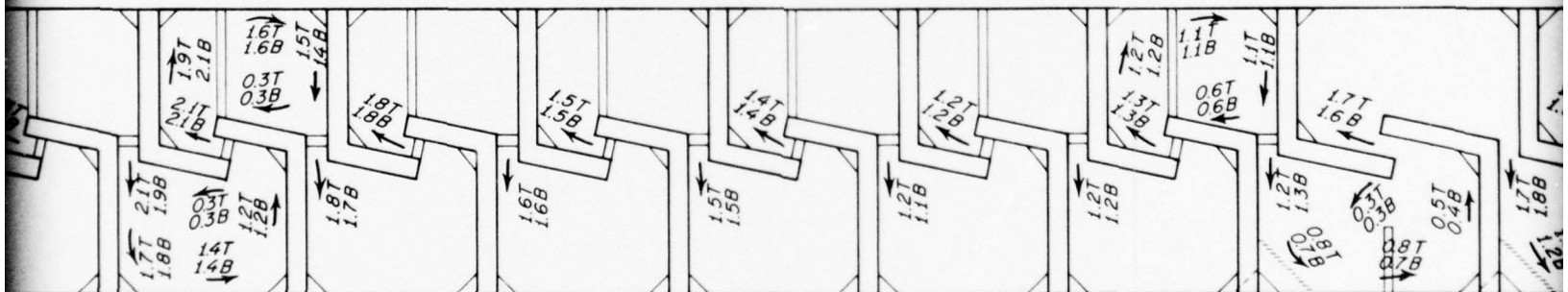

POOL 18

POOL 10

TIDE ELEVATION 112.0

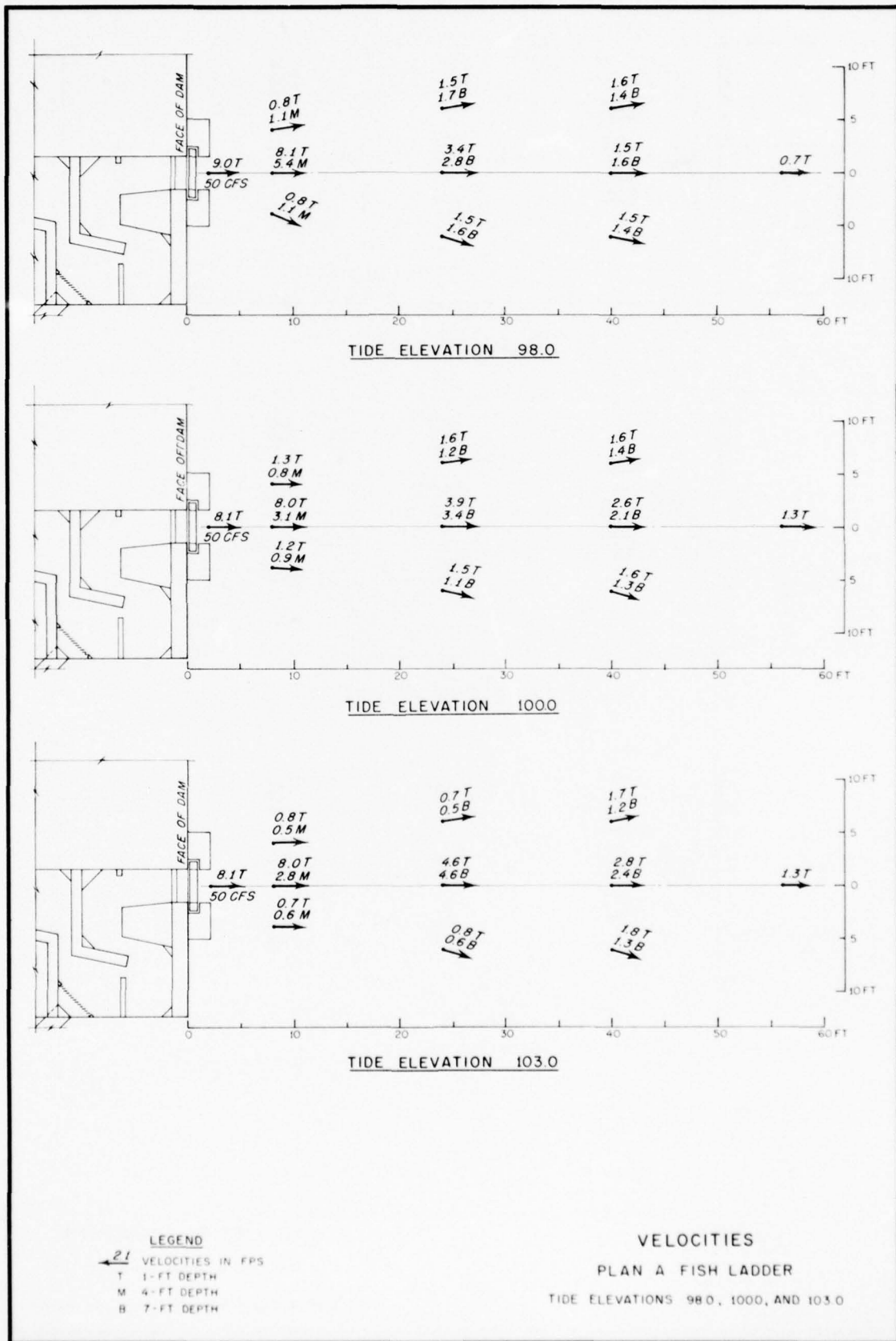

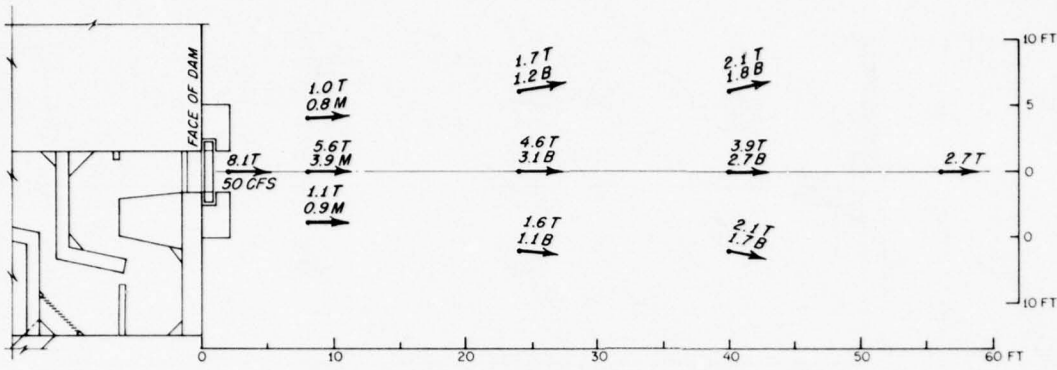

TIDE ELEVATION 107.0

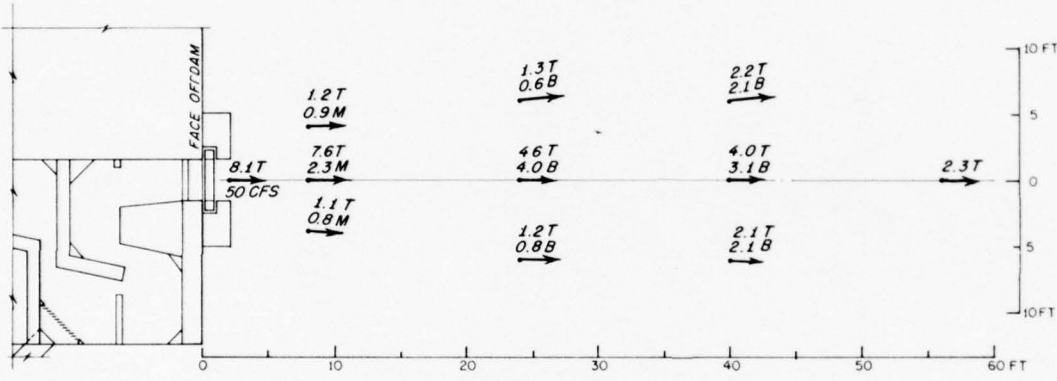

TIDE ELEVATION 110.0

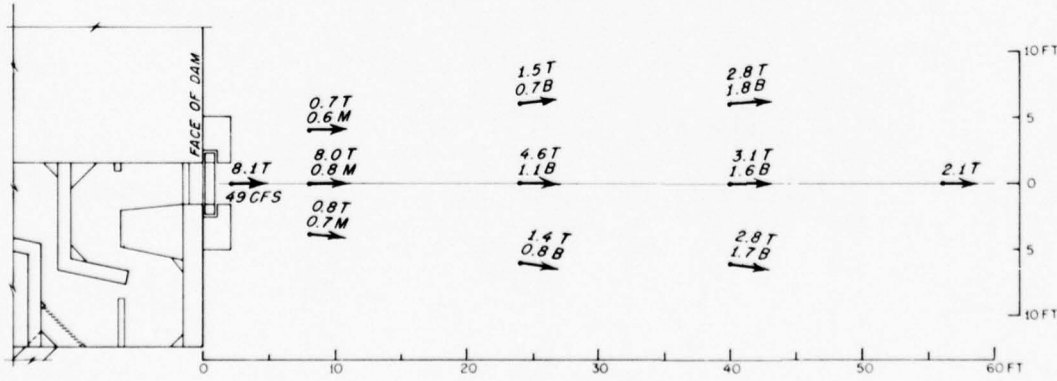

TIDE ELEVATION 112.0

LEGEND
 ← 2I VELOCITIES IN FPS
 T 1- FT DEPTH
 M 4- FT DEPTH
 B 7- FT DEPTH

ATTRACTION VELOCITIES
PLAN A FISH LADDER

TIDE ELEVATIONS 107.0, 110.0, AND 112.0

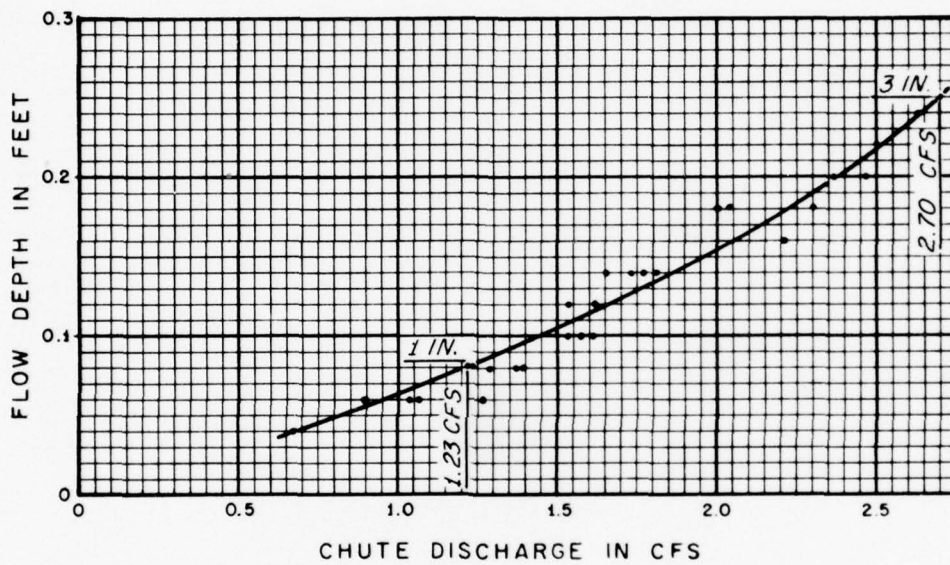

NOTE

DEPTH MEASURED AT TRANSITION FROM WEIR
TO CHUTE (2.28 FT FROM WEIR CREST, PLATE 1).

DISCHARGE RATING
FALSE WEIR EXIT CHUTE

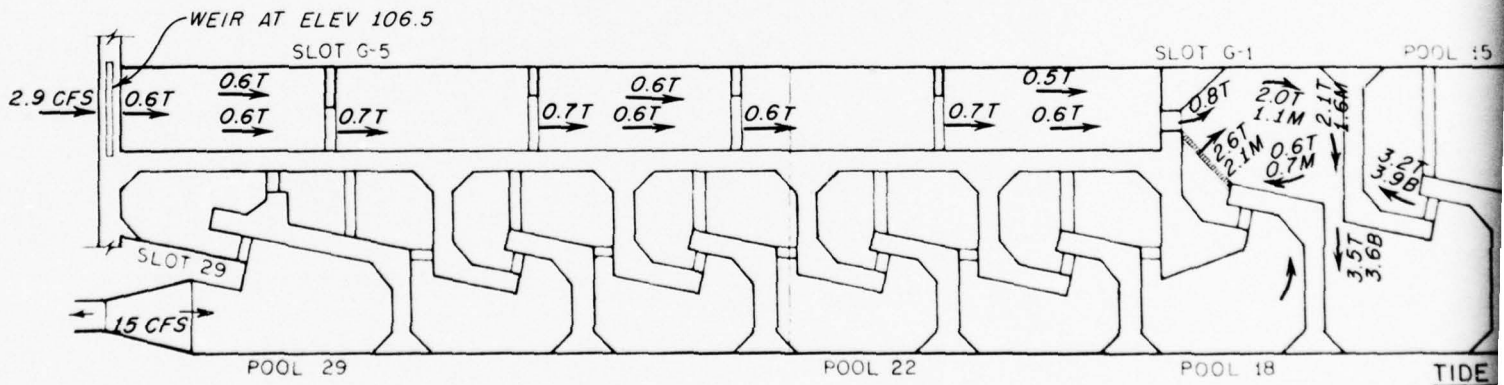
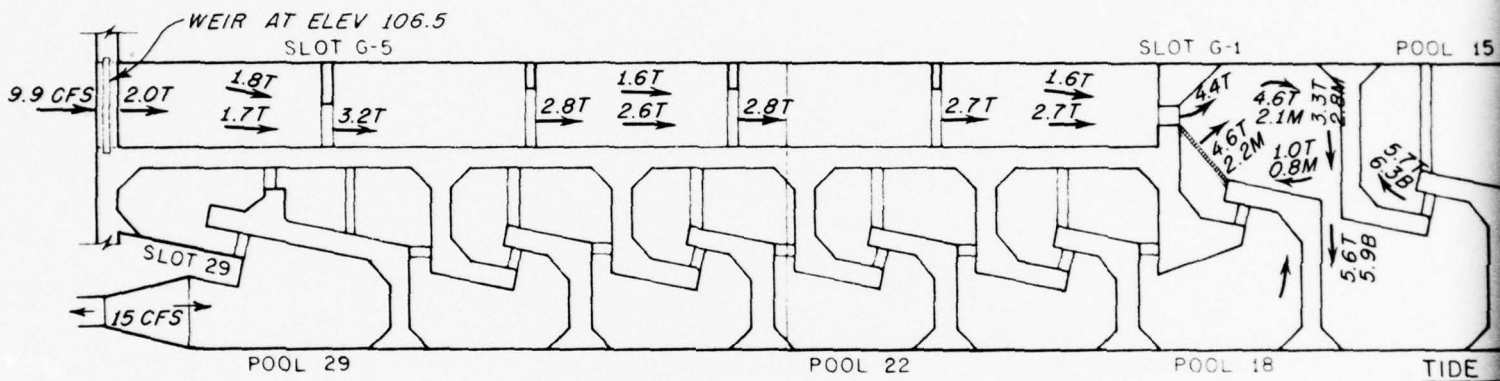
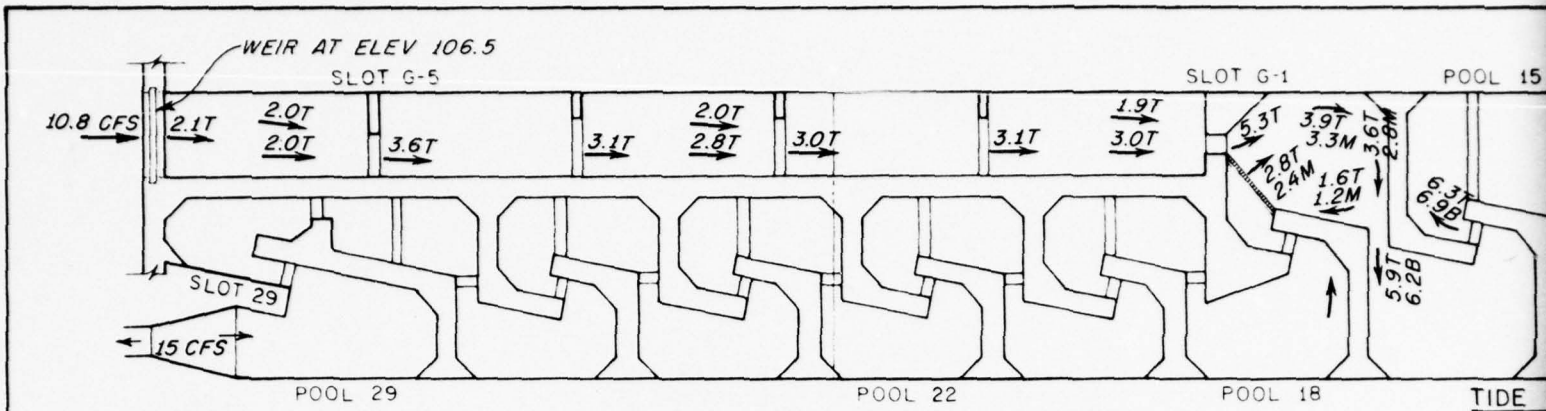

LEGEND

- 2.4 VELOCITIES IN FPS
- T 1-FT DEPTH
- M 4-FT DEPTH
- B 7-FT DEPTH OR 1 FT ABOVE
INVERT OR SILL OF UPSTREAM SLOT
- * 1 FT ABOVE SILL

POOL 15

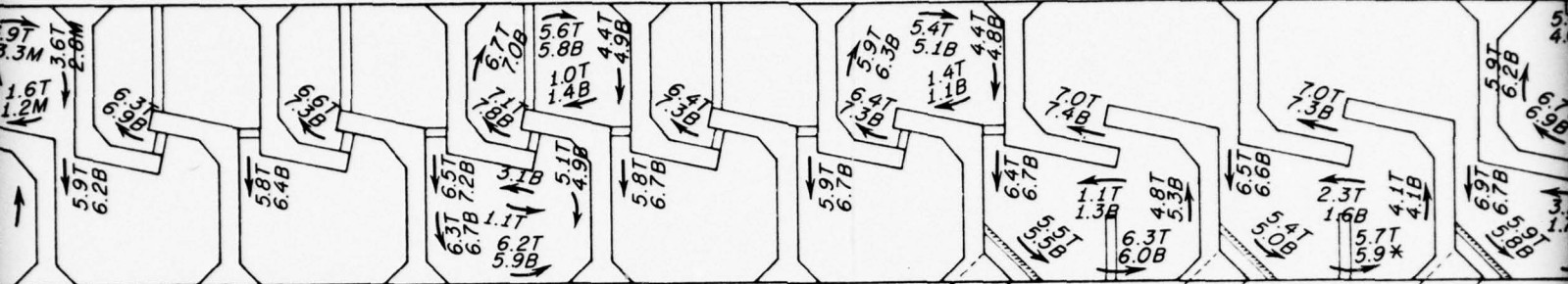

TIDE ELEVATION 98.5

POOL 10

POOL 15

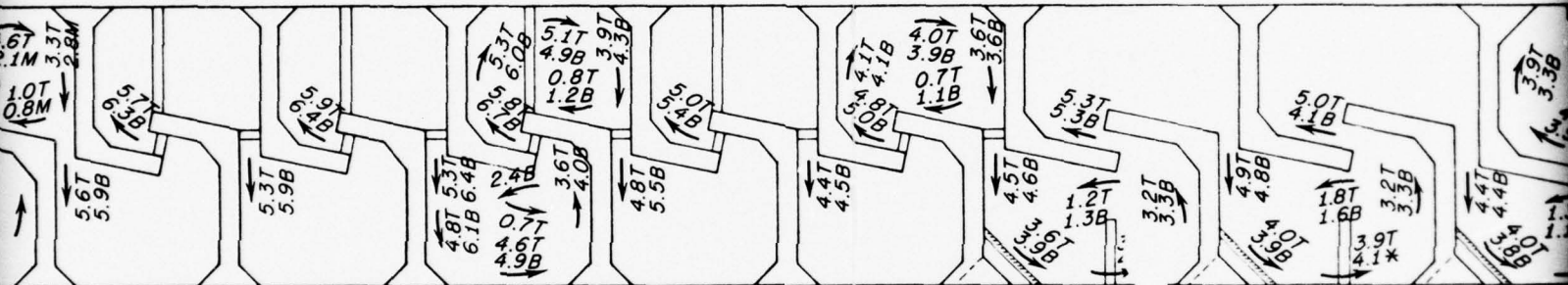

TIDE ELEVATION 102.0

POOL 10

POOL 15

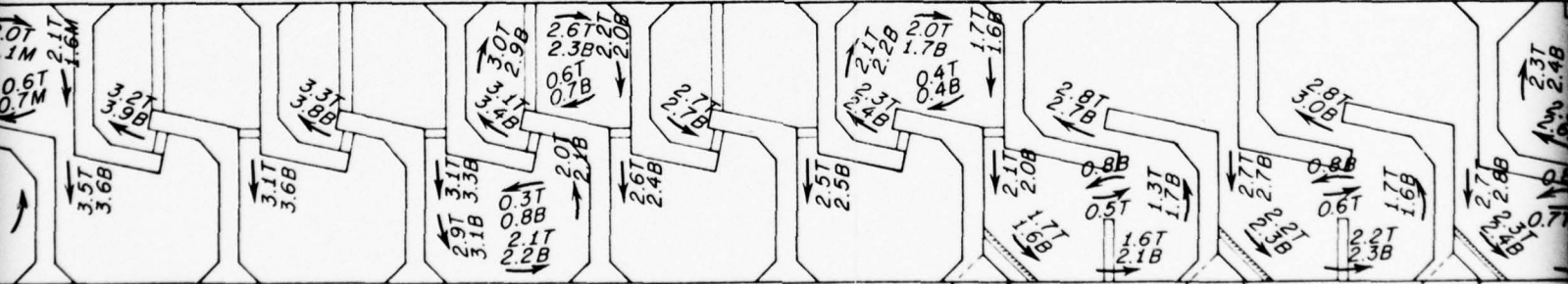

TIDE ELEVATION 106.0

POOL 10

VELOCITIES

PLAN B FISH L

TIDE ELEVATIONS 98.5, 1

RIVER ELEVATION

2

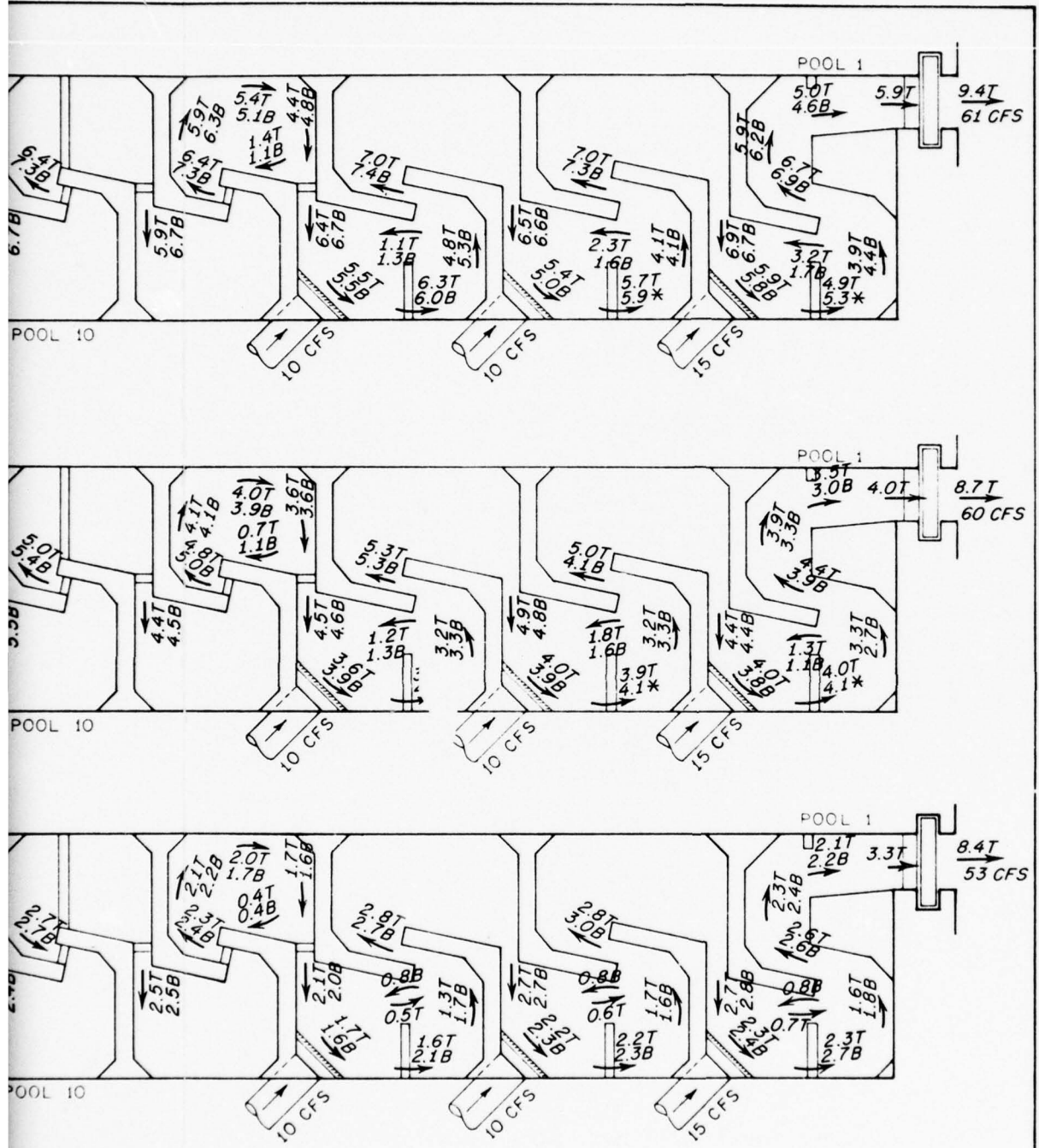

VELOCITIES

PLAN B FISH LADDER

TIDE ELEVATIONS 98.5, 102.0, AND 106.0

RIVER ELEVATION 108.5

3

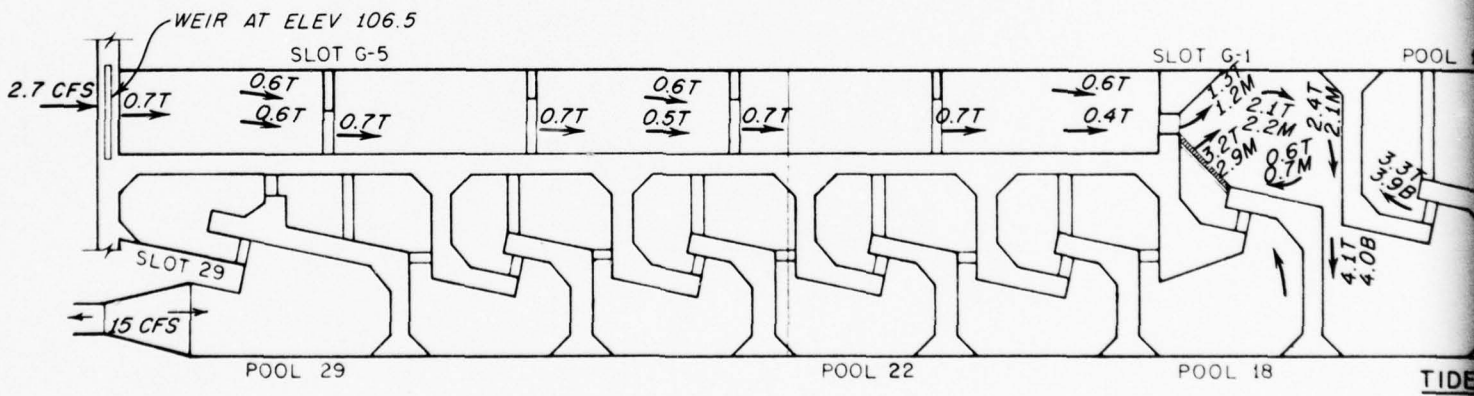
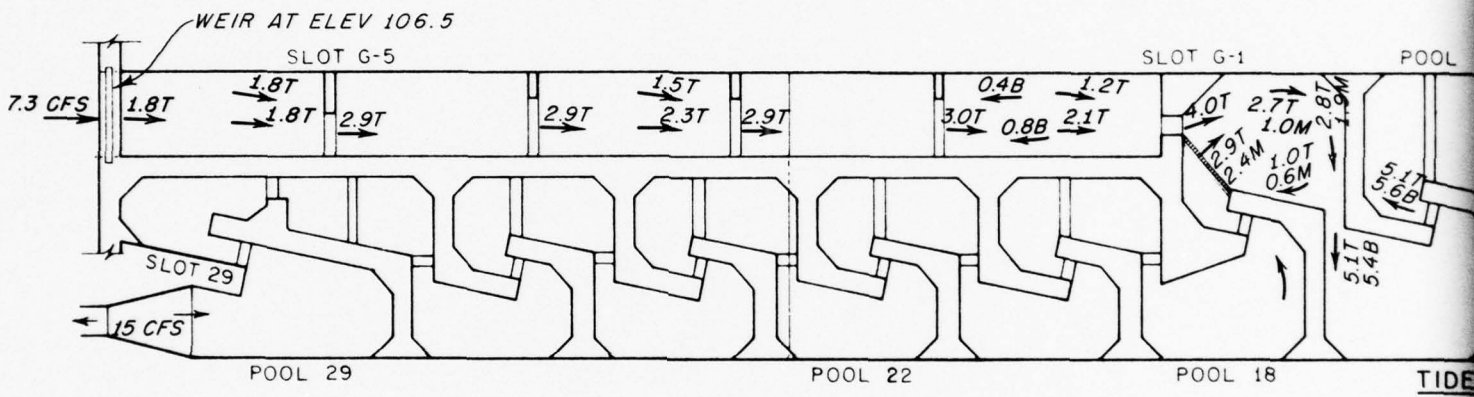
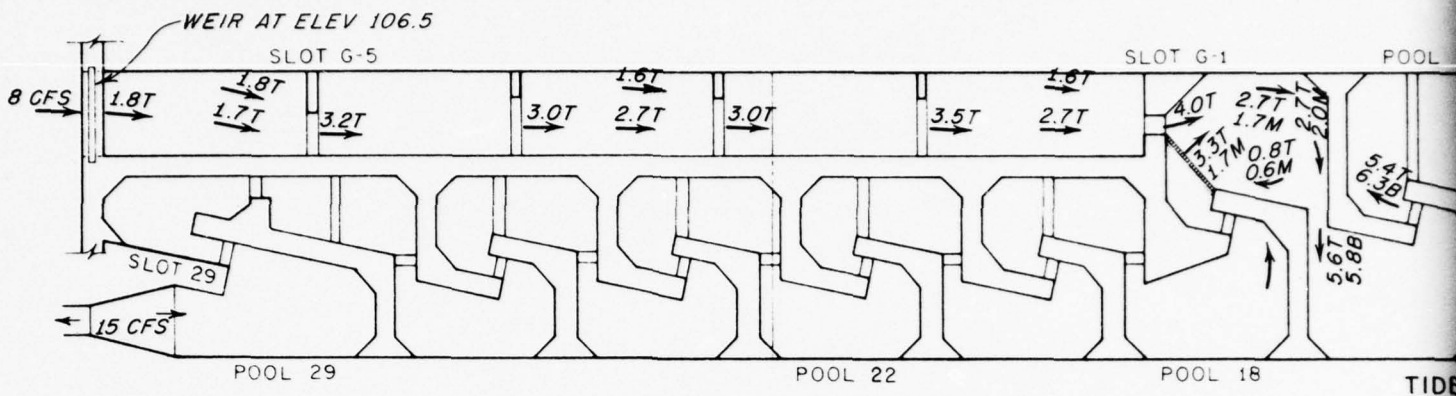

LEGEND

- 2.4 VELOCITIES IN FPS
- T 1- FT DEPTH
- M 4- FT DEPTH
- B 7- FT DEPTH OR 1 FT ABOVE INVERT OR SILL OF UPSTREAM SLOT
- * 1 FT ABOVE SILL

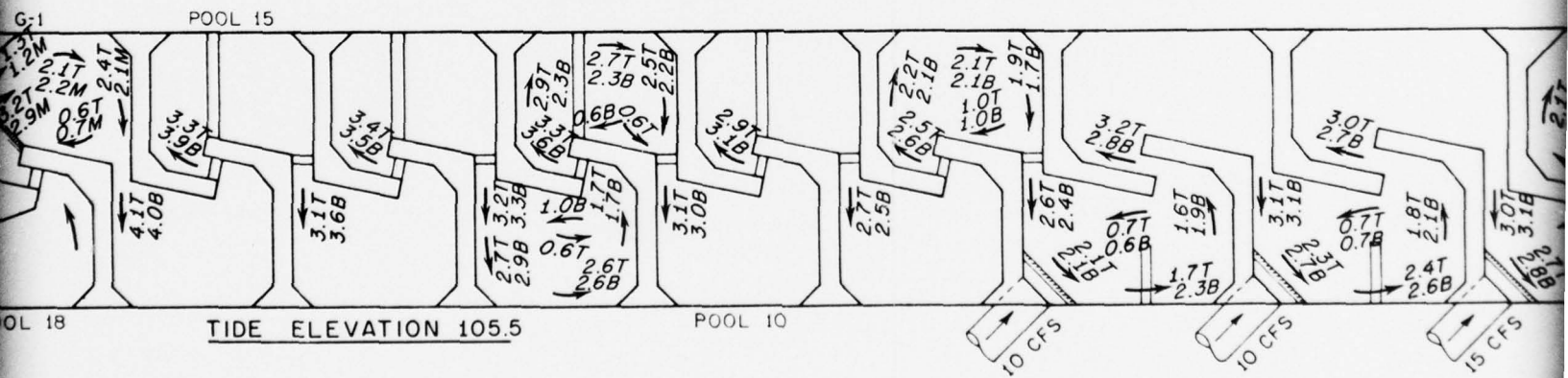
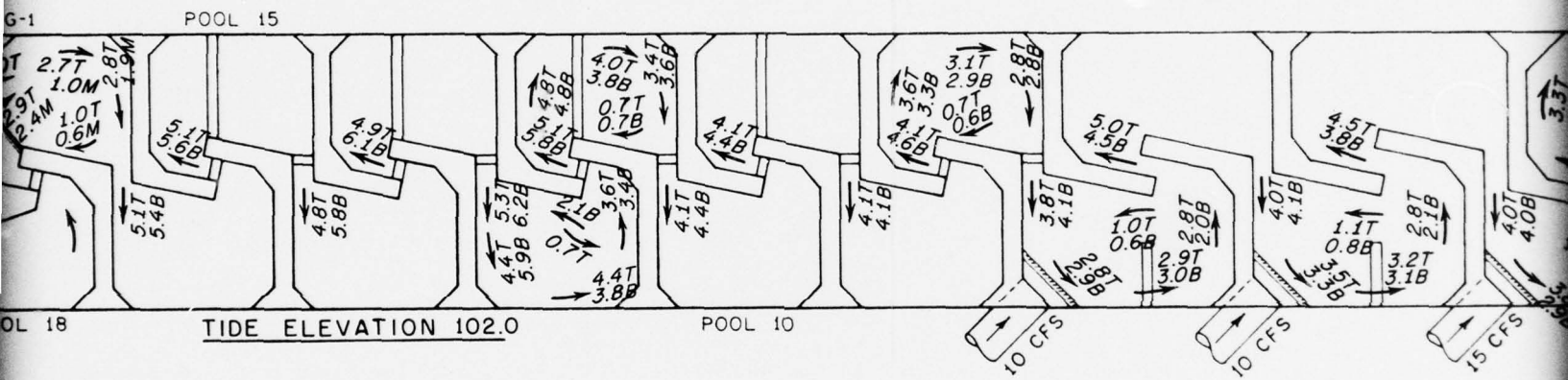
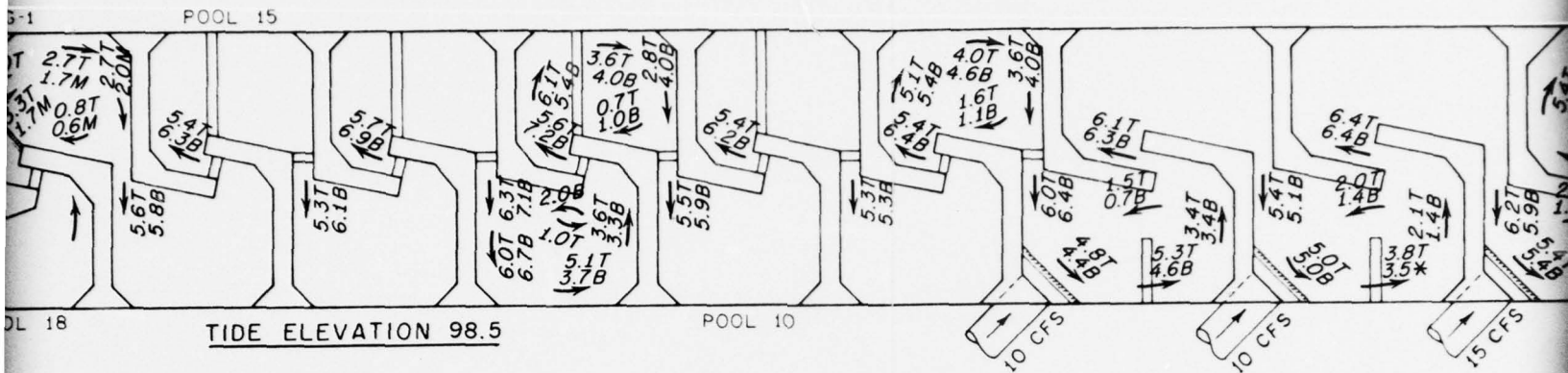

VELOCIT

PLAN B FISH

TIDE ELEVATIONS 98.5

RIVER ELEVATI

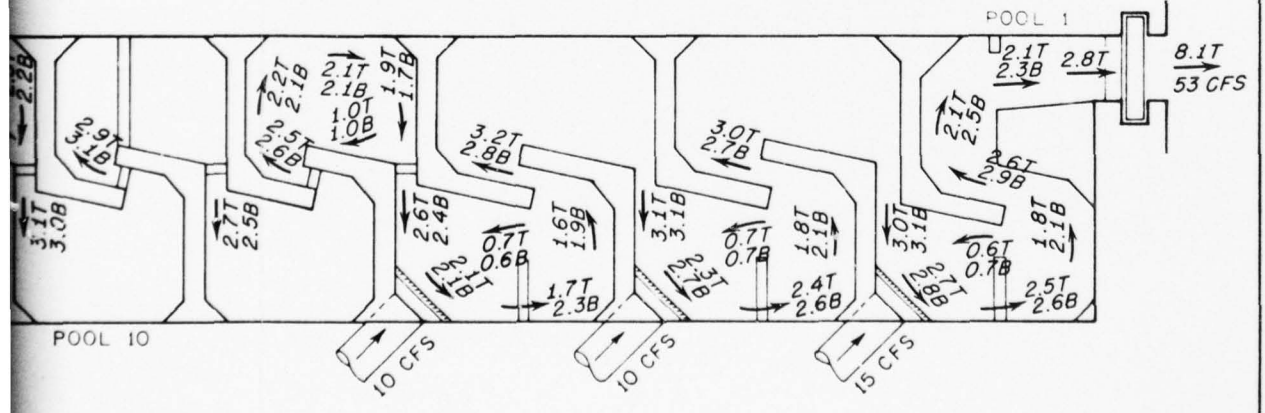
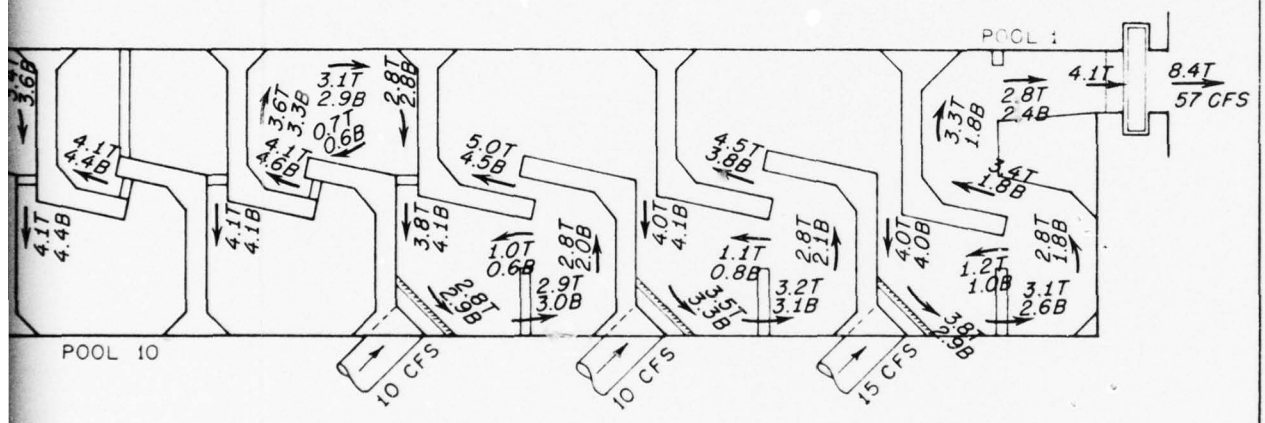
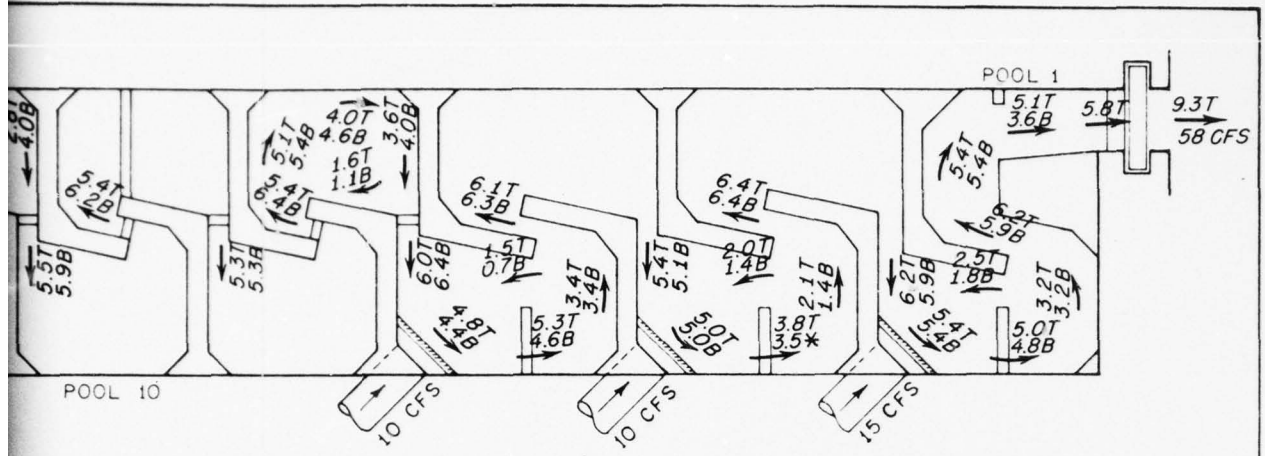

VELOCITIES

PLAN B FISH LADDER

TIDE ELEVATIONS 98.5, 102.0, AND 105.5

RIVER ELEVATION 108.0

3

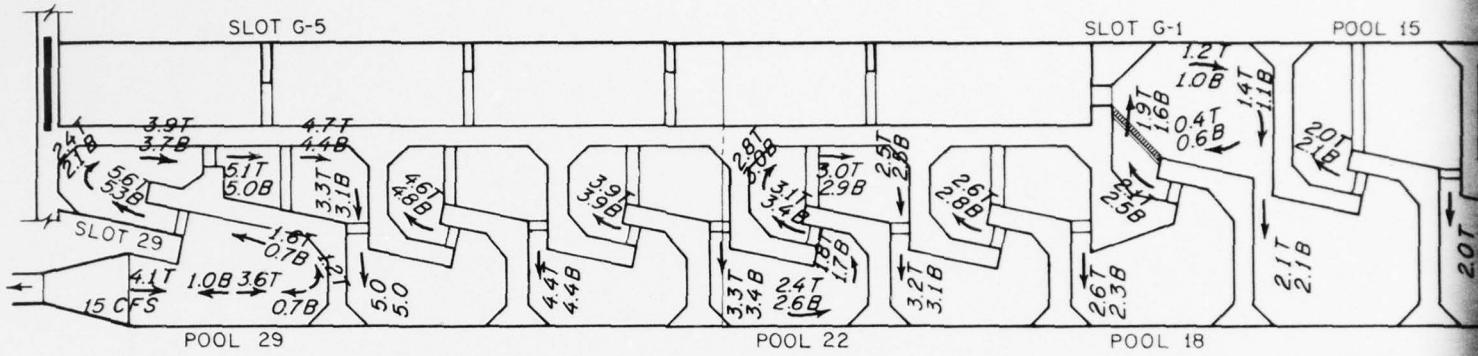

TIDE ELE

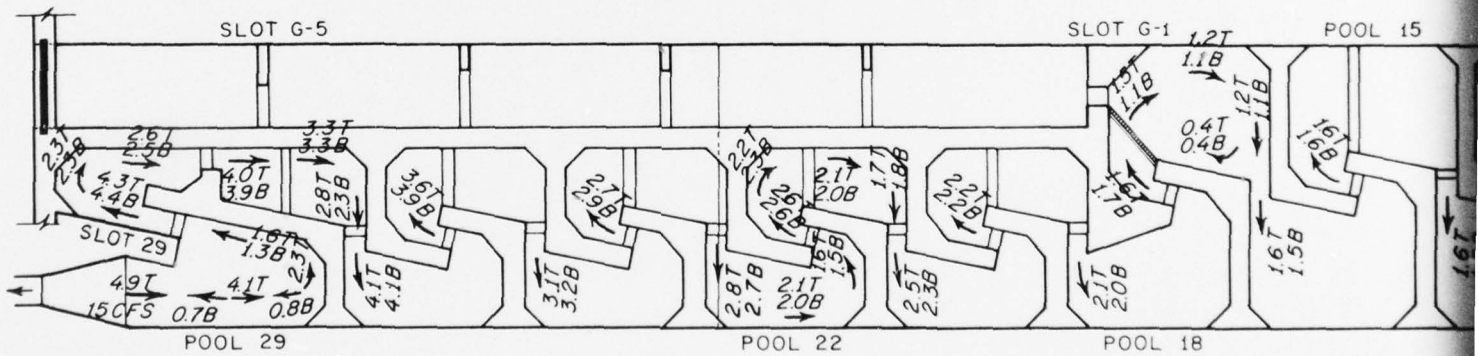

TIDE ELE

LEGEND

- 2.4 VELOCITIES IN FPS
- T 1-FT DEPTH
- M 4-FT DEPTH
- B 7-FT DEPTH OR 1 FT ABOVE INVERT OR SILL OF UPSTREAM SLOT

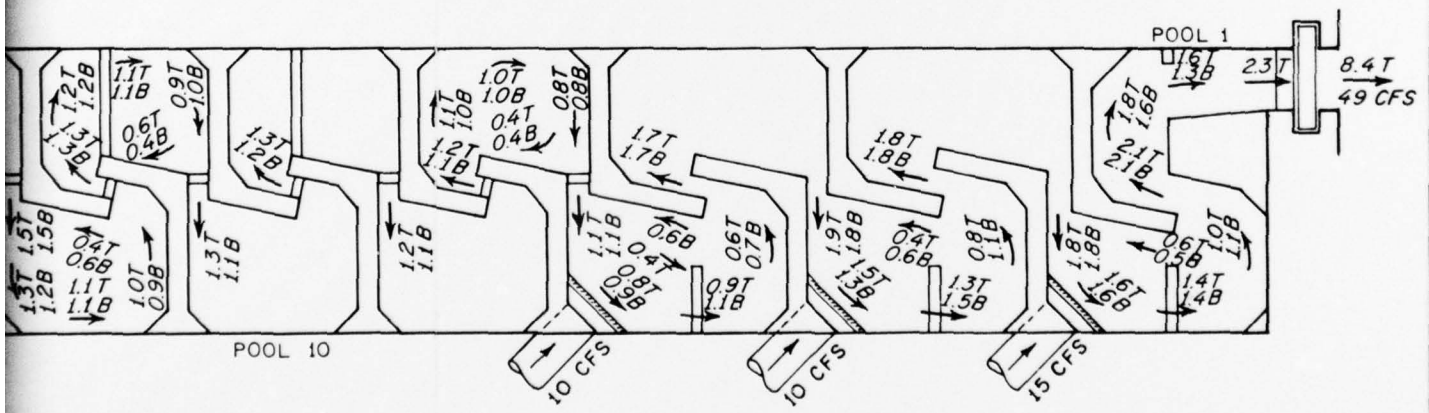
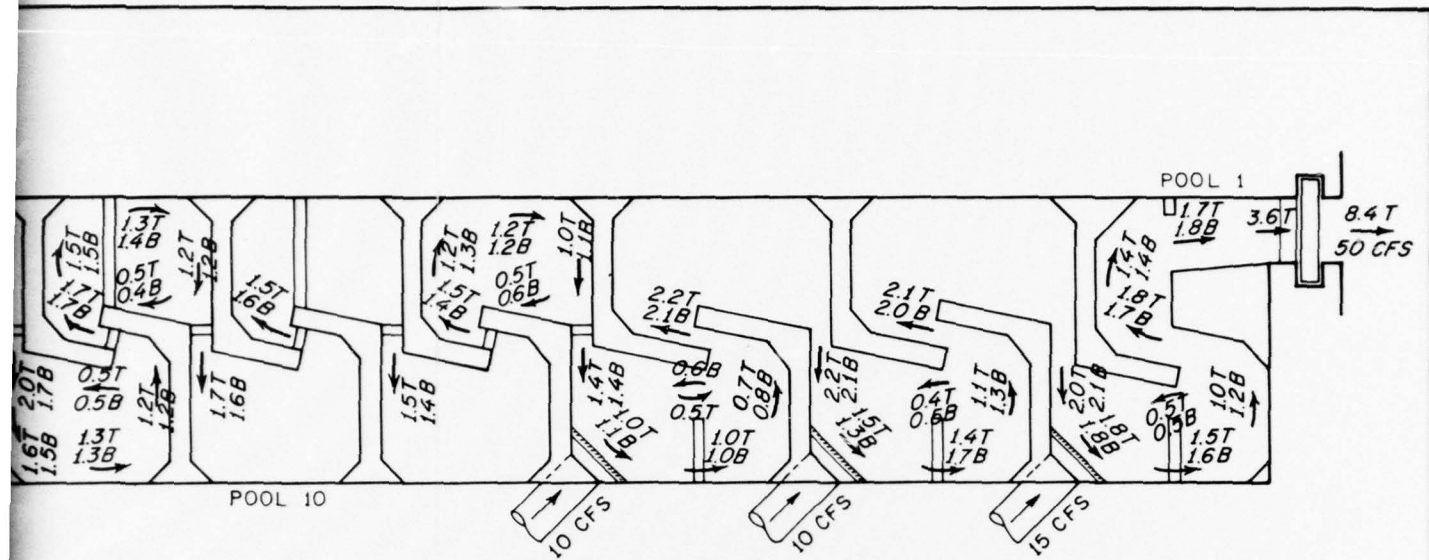

VELOCITIES
 PLAN B FISH LADDER
 TIDE ELEVATIONS 110.0 AND 112.0
 RIVER ELEVATION 108.0

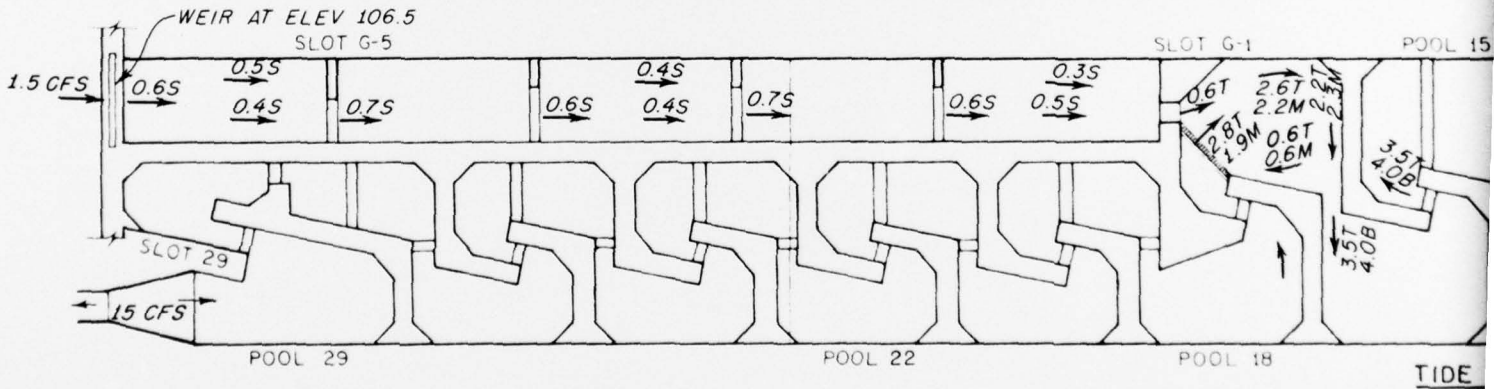
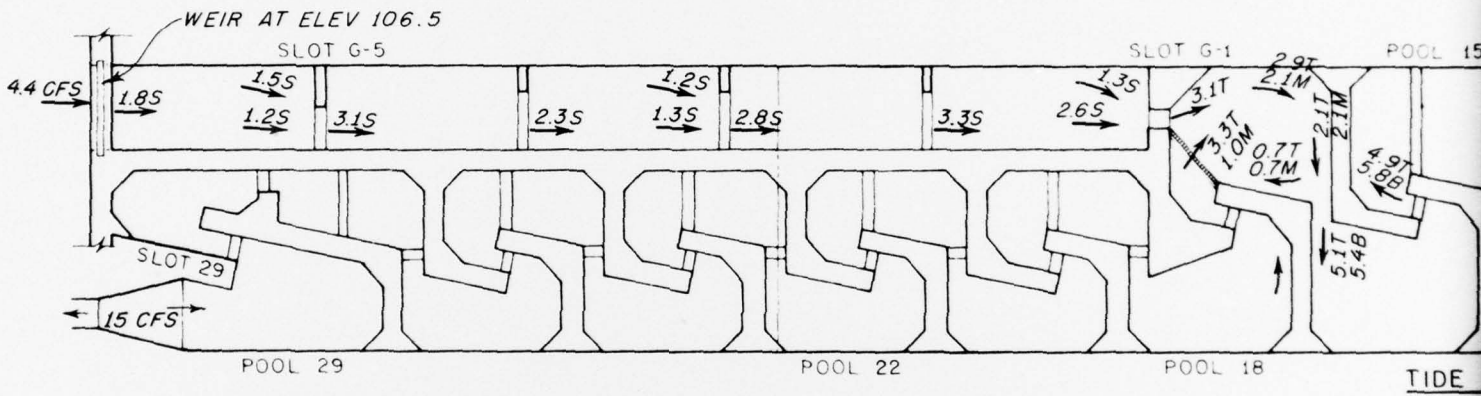
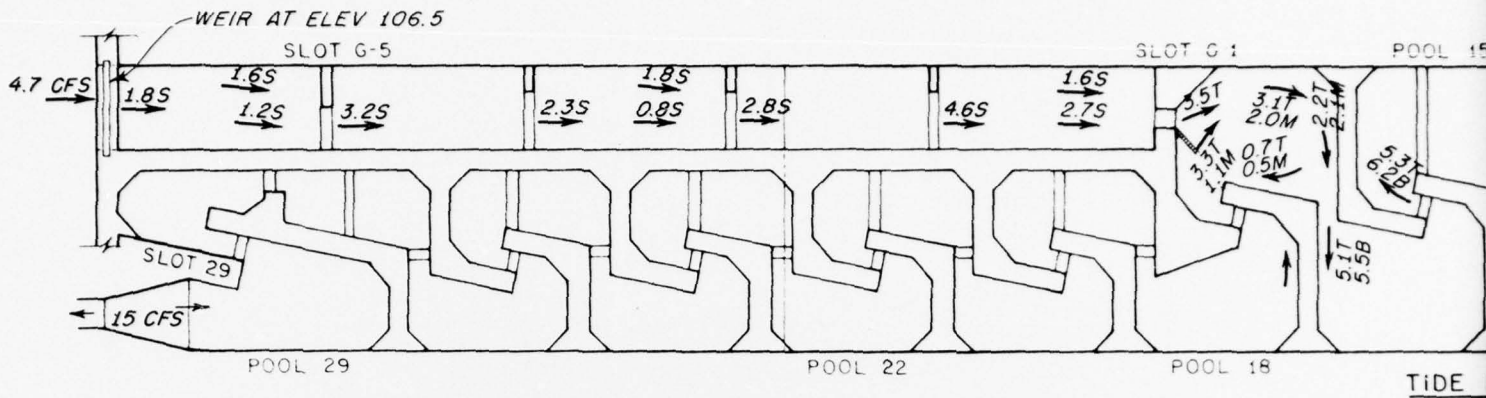

LEGEND

- VELOCITIES IN FPS
 T 1- FT DEPTH
 M 4- FT DEPTH
 B 7- FT DEPTH OR 1 FT ABOVE
 INVERT OR SILL OF UPSTREAM SLOT
 * 1 FT ABOVE SILL
 S 0.5- FT DEPTH

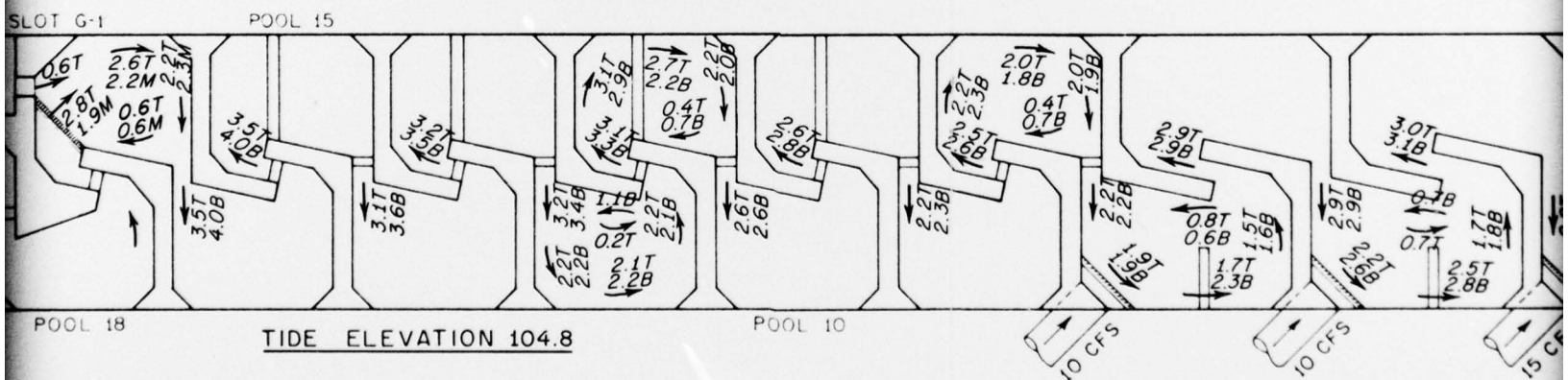
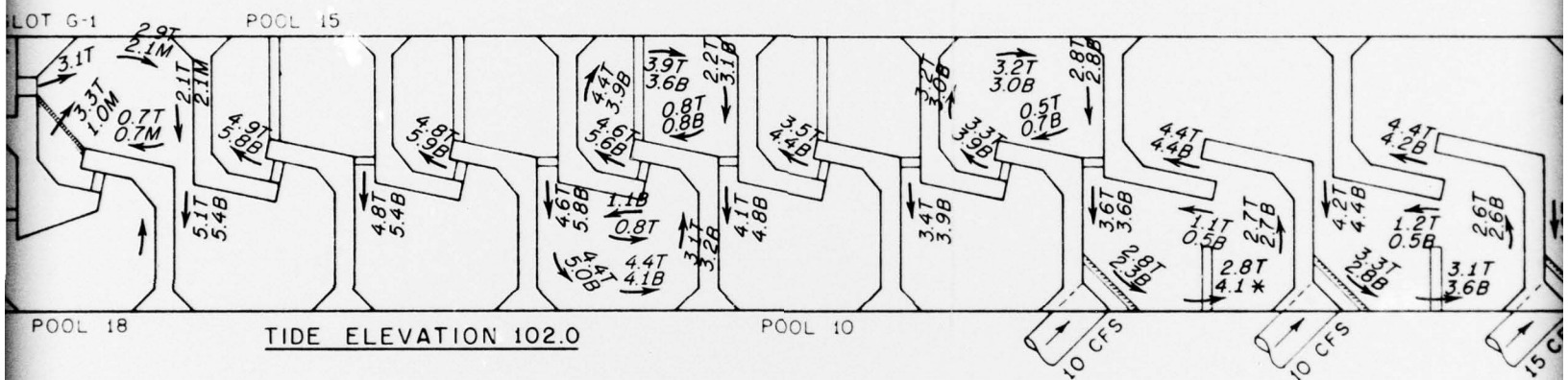
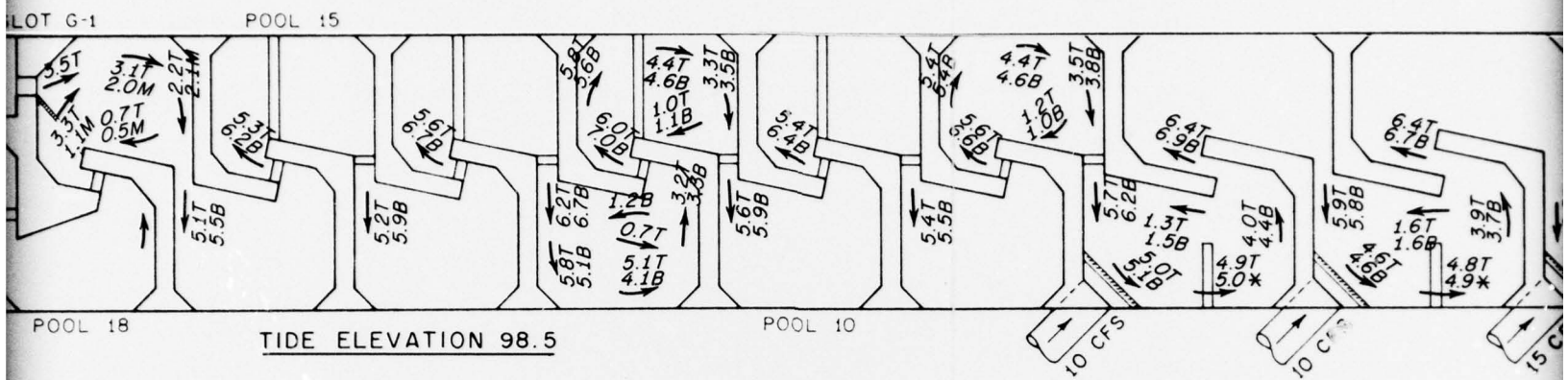

2

VELO
 PLAN B F
 TIDE ELEVATIONS
 RIVER ELE

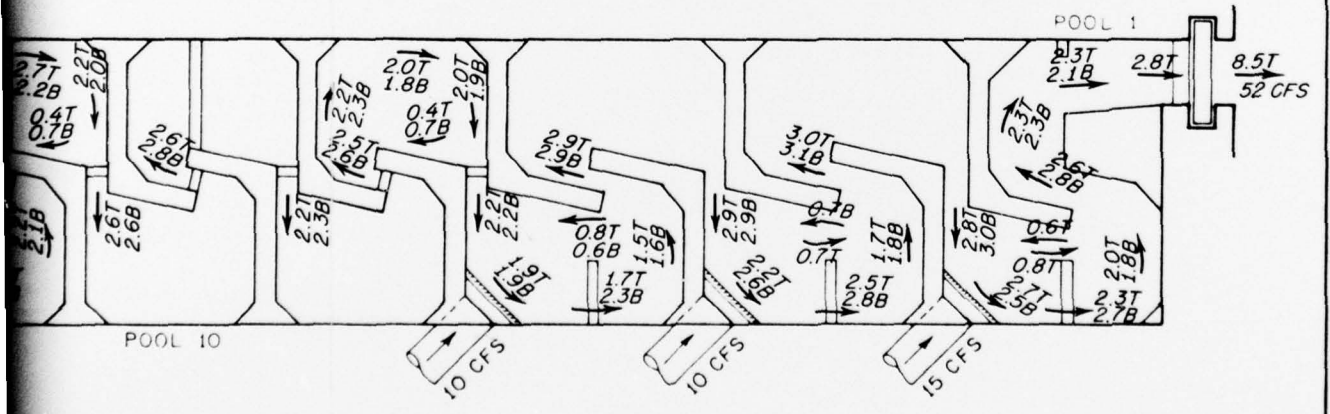
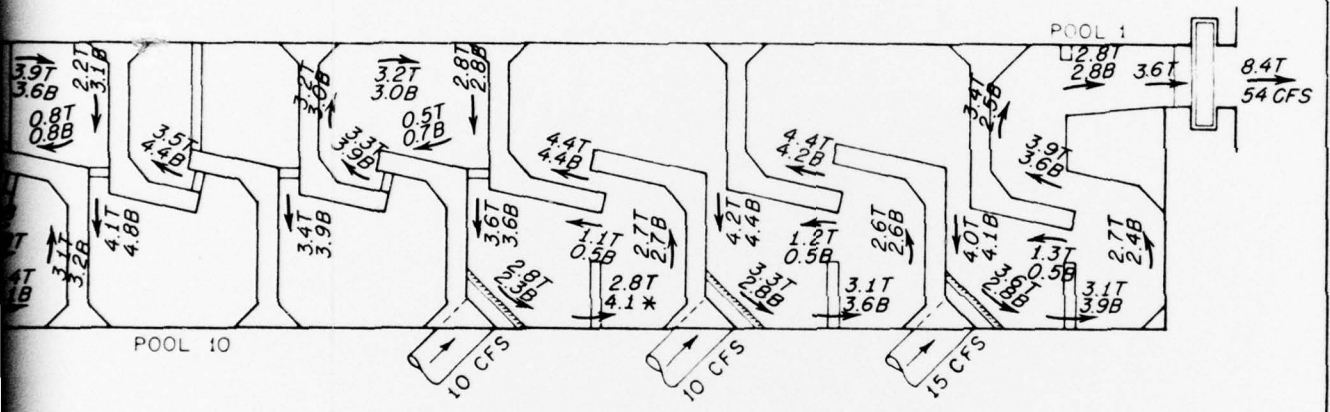
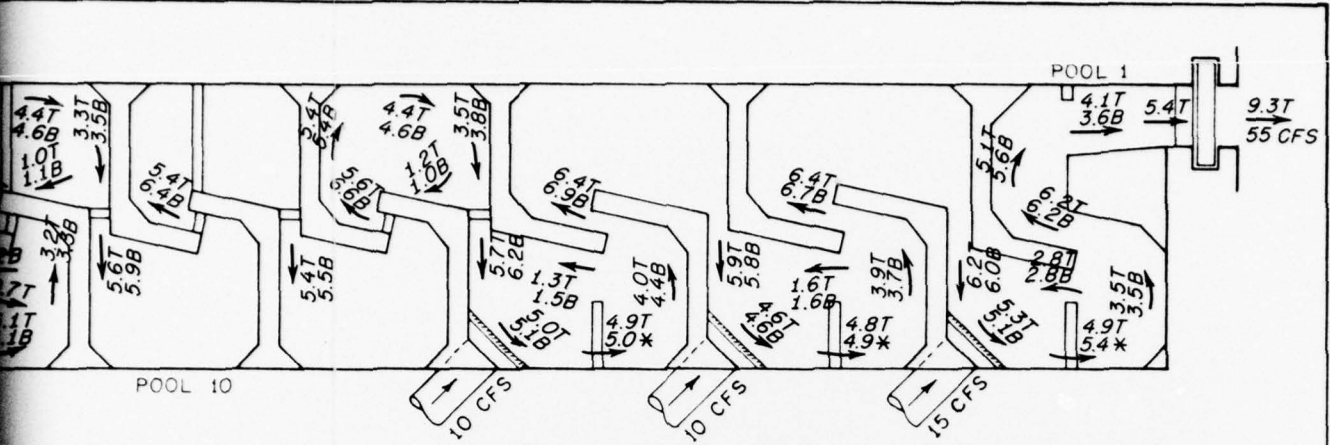

VELOCITIES

PLAN B FISH LADDER

TIDE ELEVATIONS 98.5, 102.0, AND 104.8

RIVER ELEVATION 107.5

3

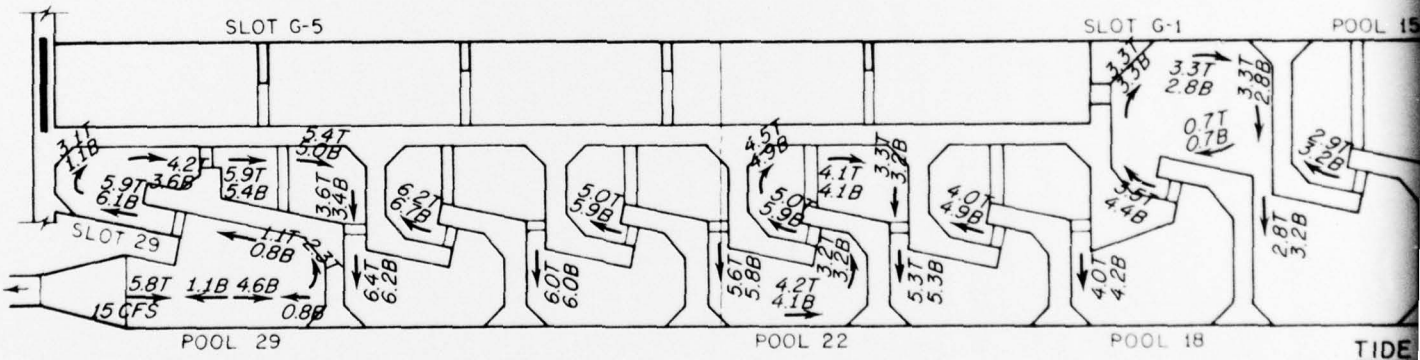
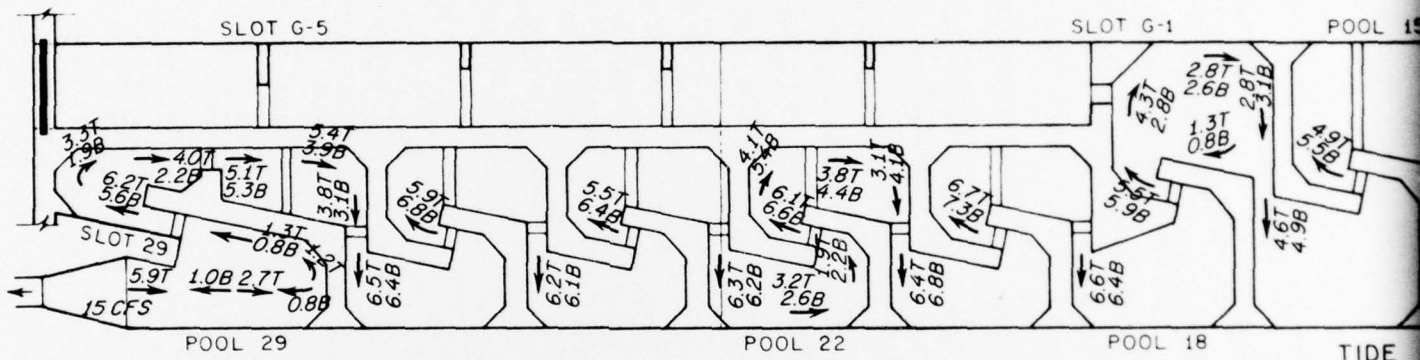
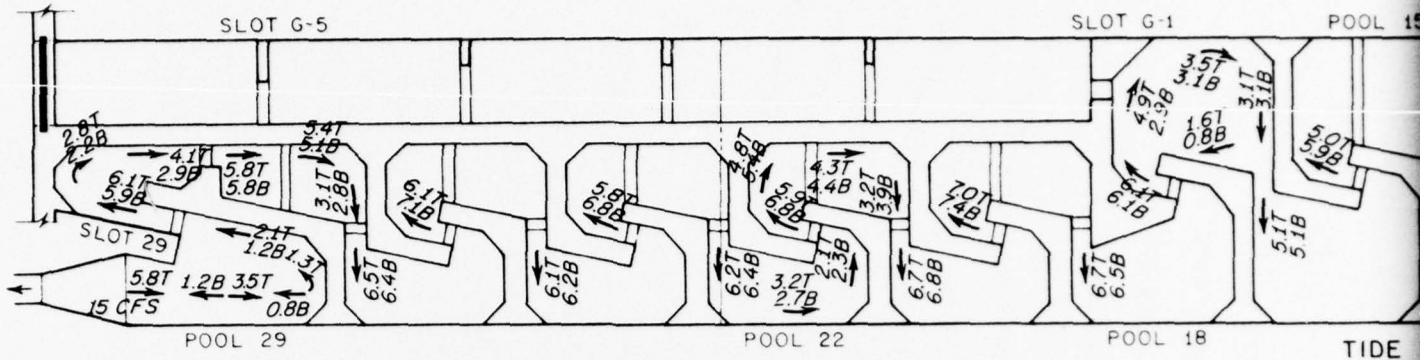

LEGEND

- ← 2.4 VELOCITIES IN FPS
- T 1- FT DEPTH
- M 4- FT DEPTH
- B 7- FT DEPTH OR 1 FT ABOVE INVERT OR SILL OF UPSTREAM SLOT
- * 1 FT ABOVE SILL.

1

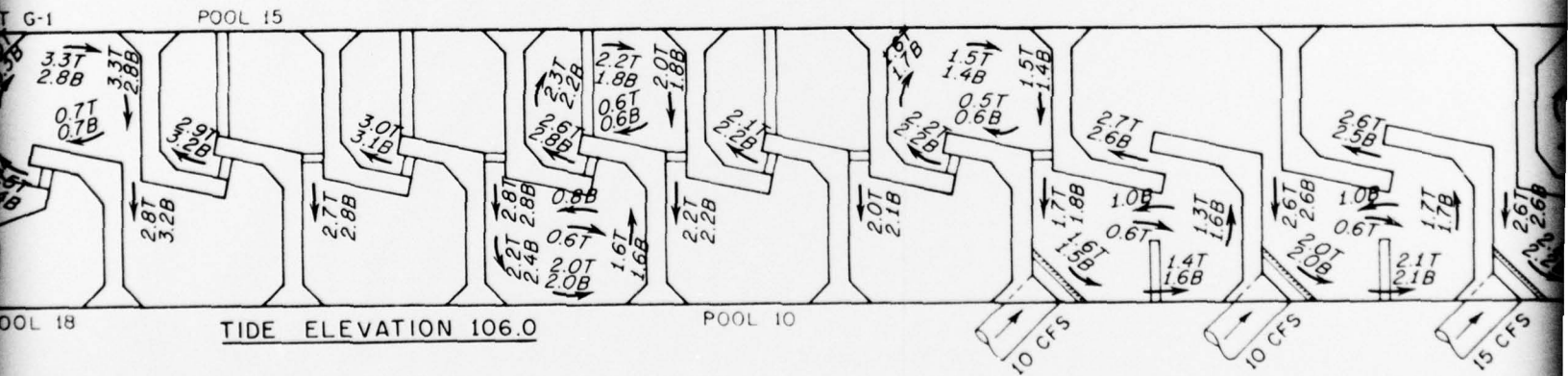
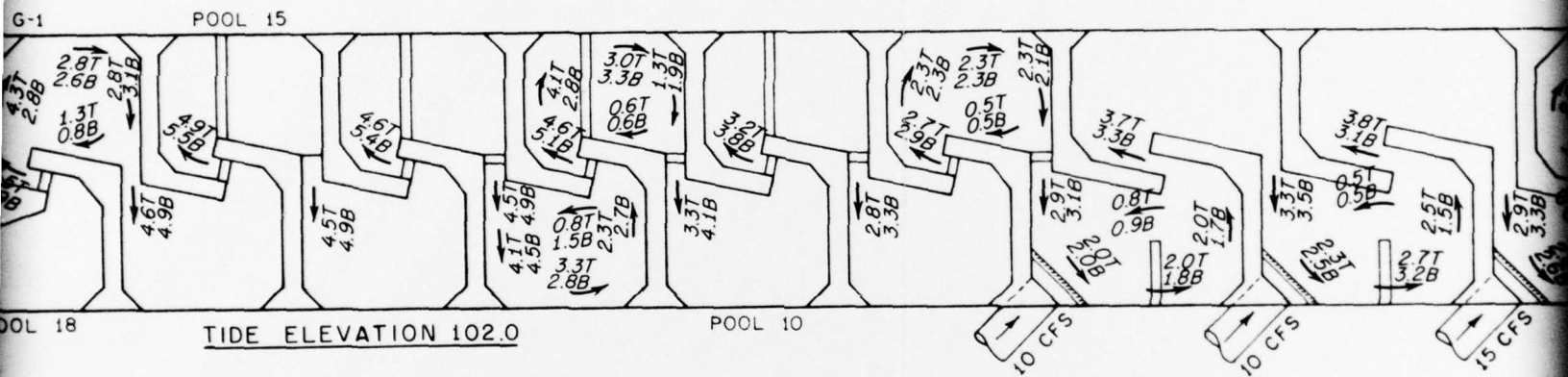
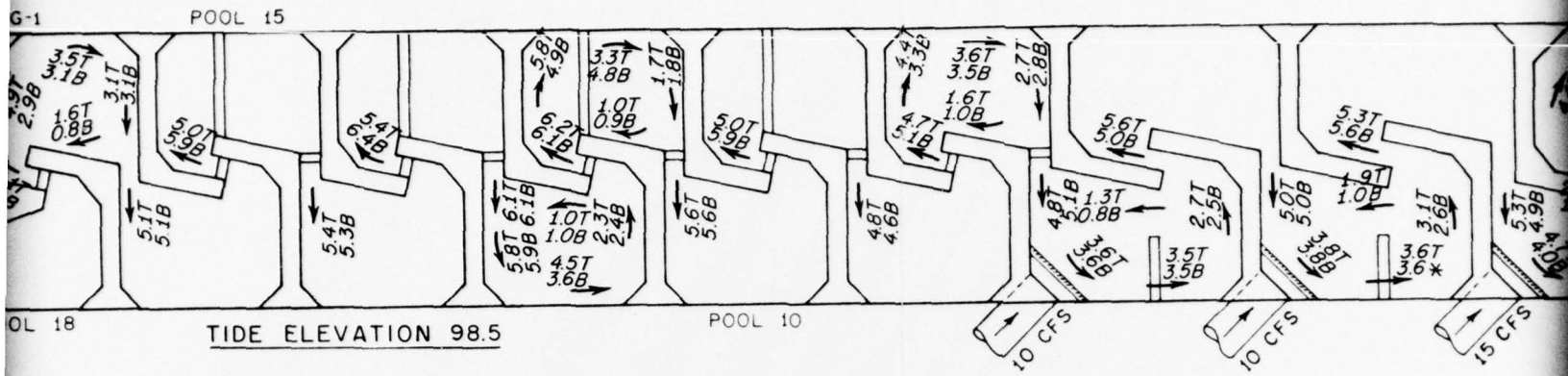

LOW TIDE EXIT CLOSED
 POOL 17 BARRIER REMOVED

VELO
 PLAN B F
 TIDE ELEVATIONS

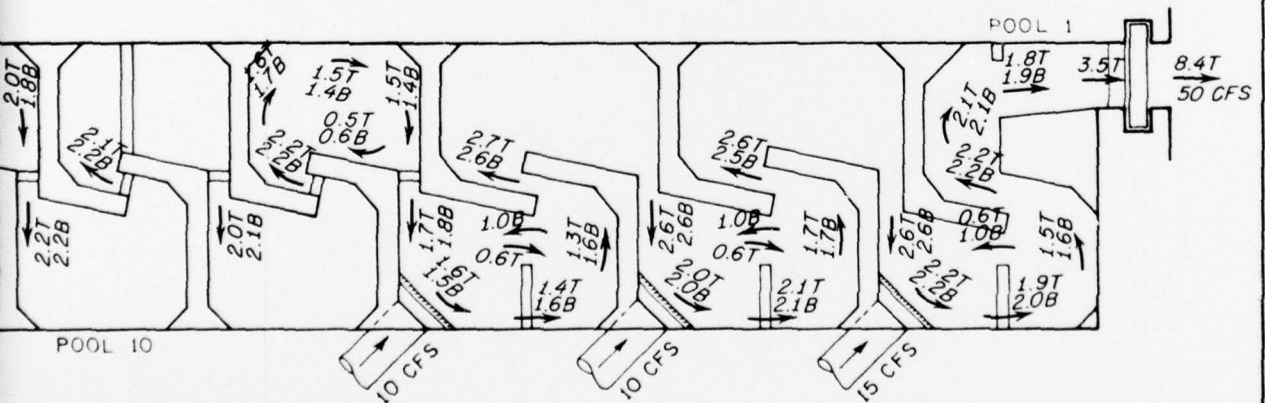
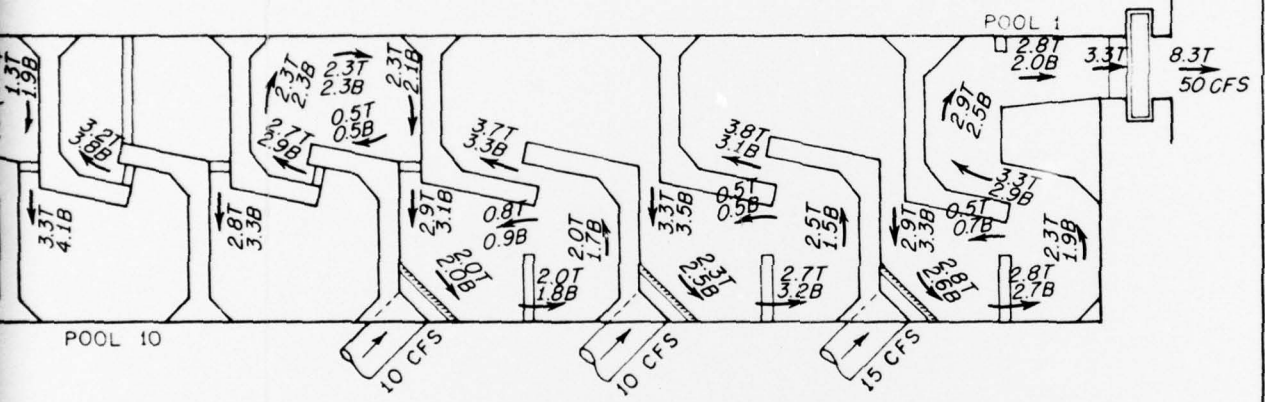
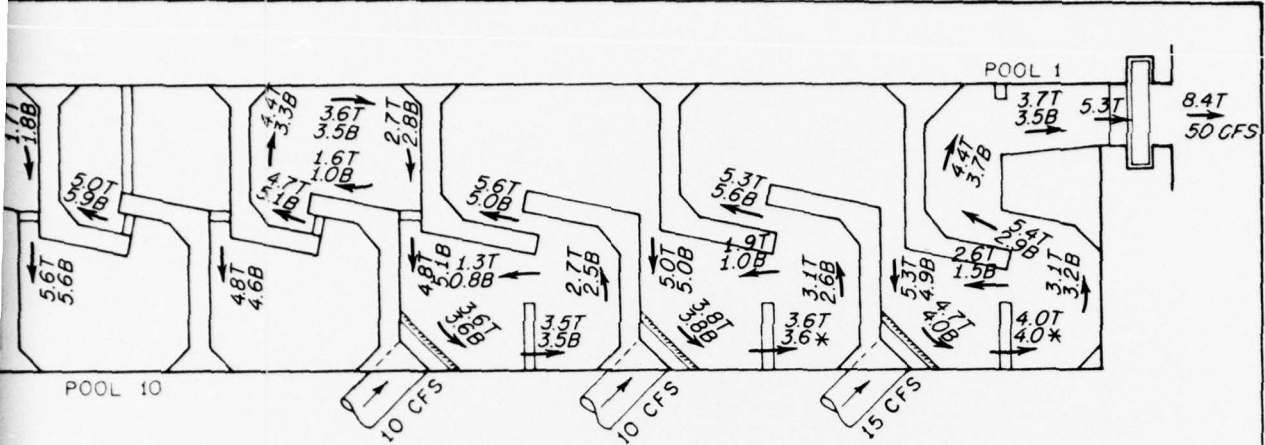

LOW TIDE EXIT CLOSED
 POOL 17 BARRIER REMOVED

VELOCITIES
 PLAN B FISH LADDER
 TIDE ELEVATIONS 98.5, 102.0, AND 106.0

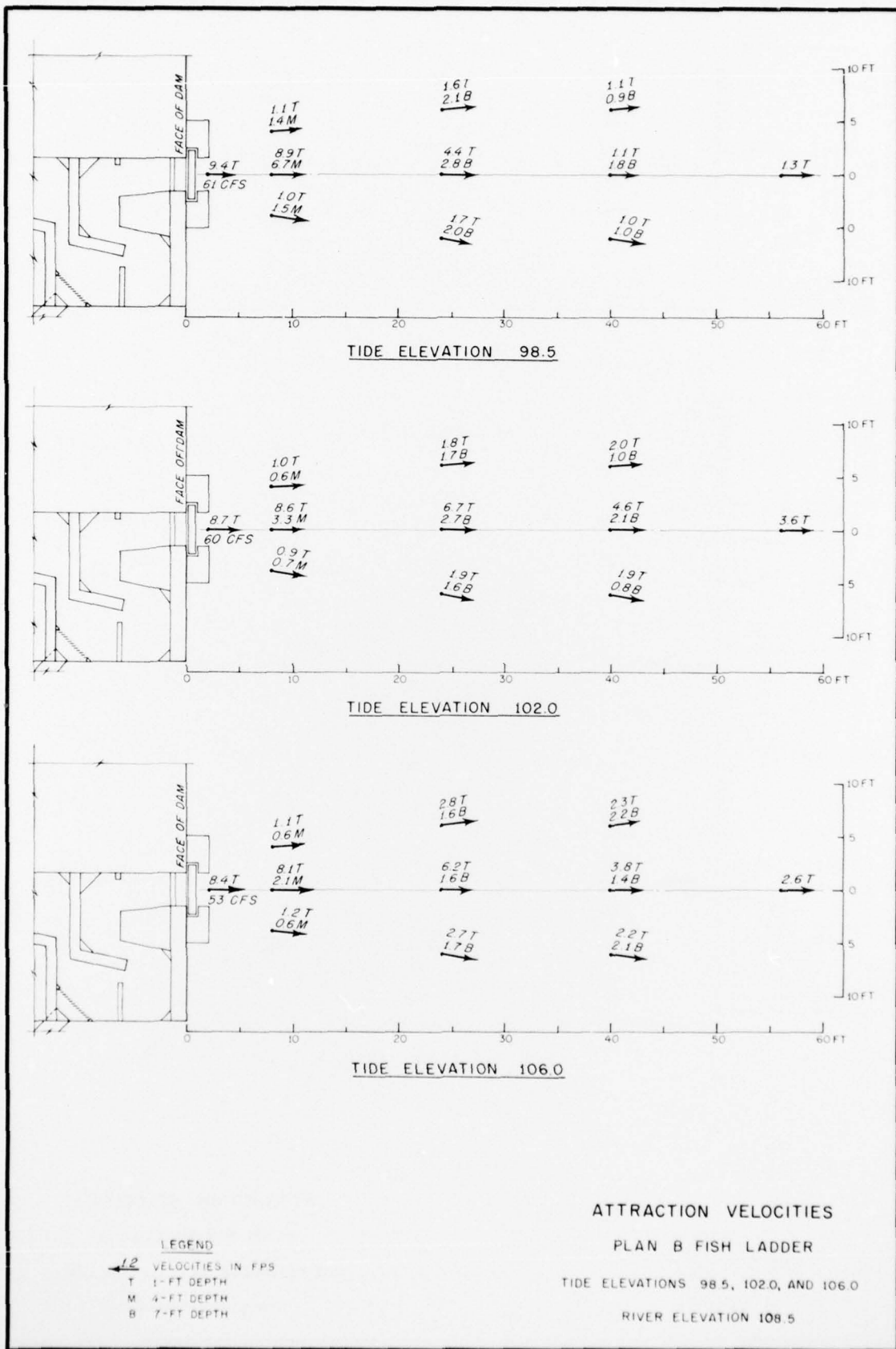

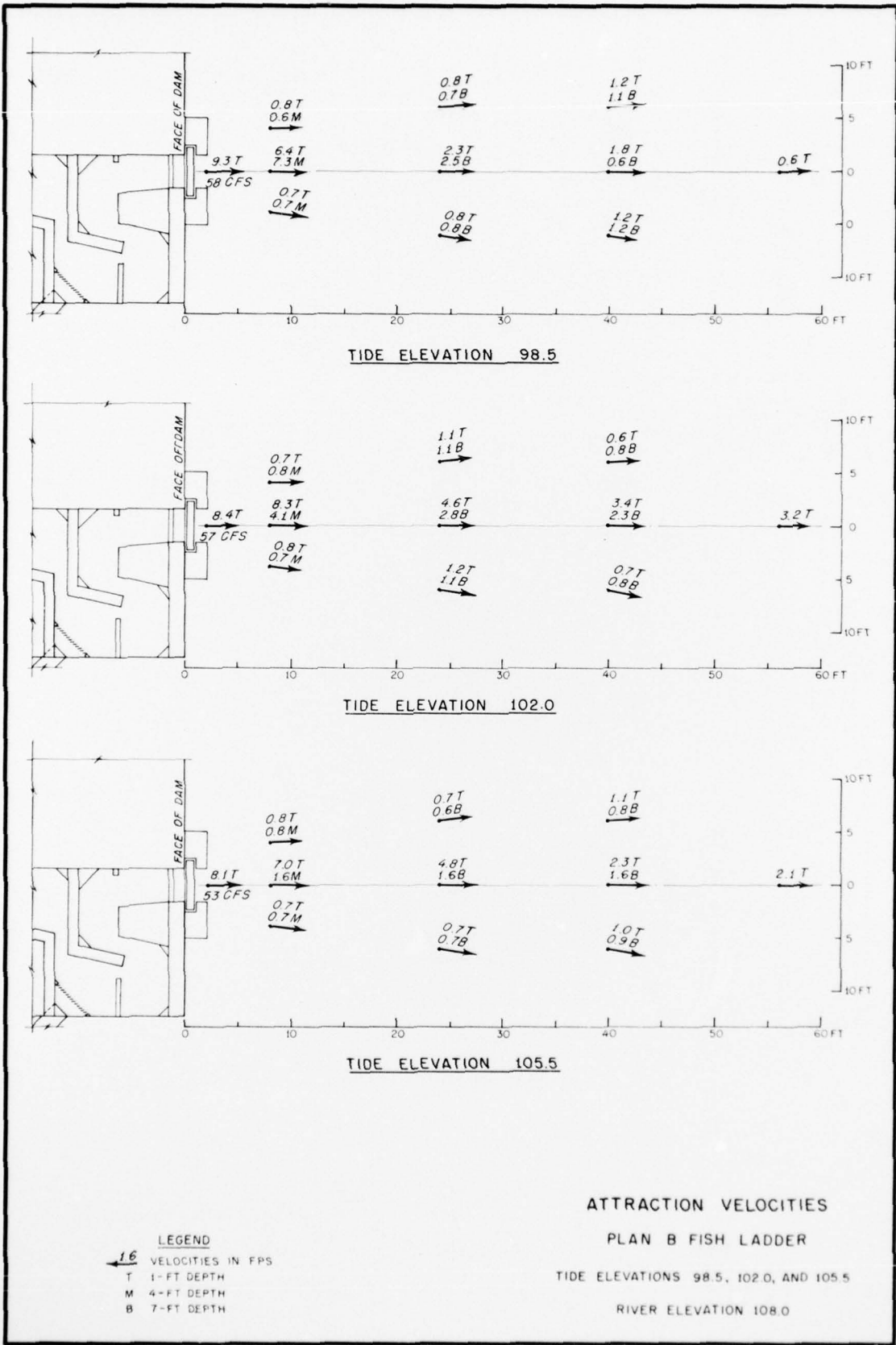

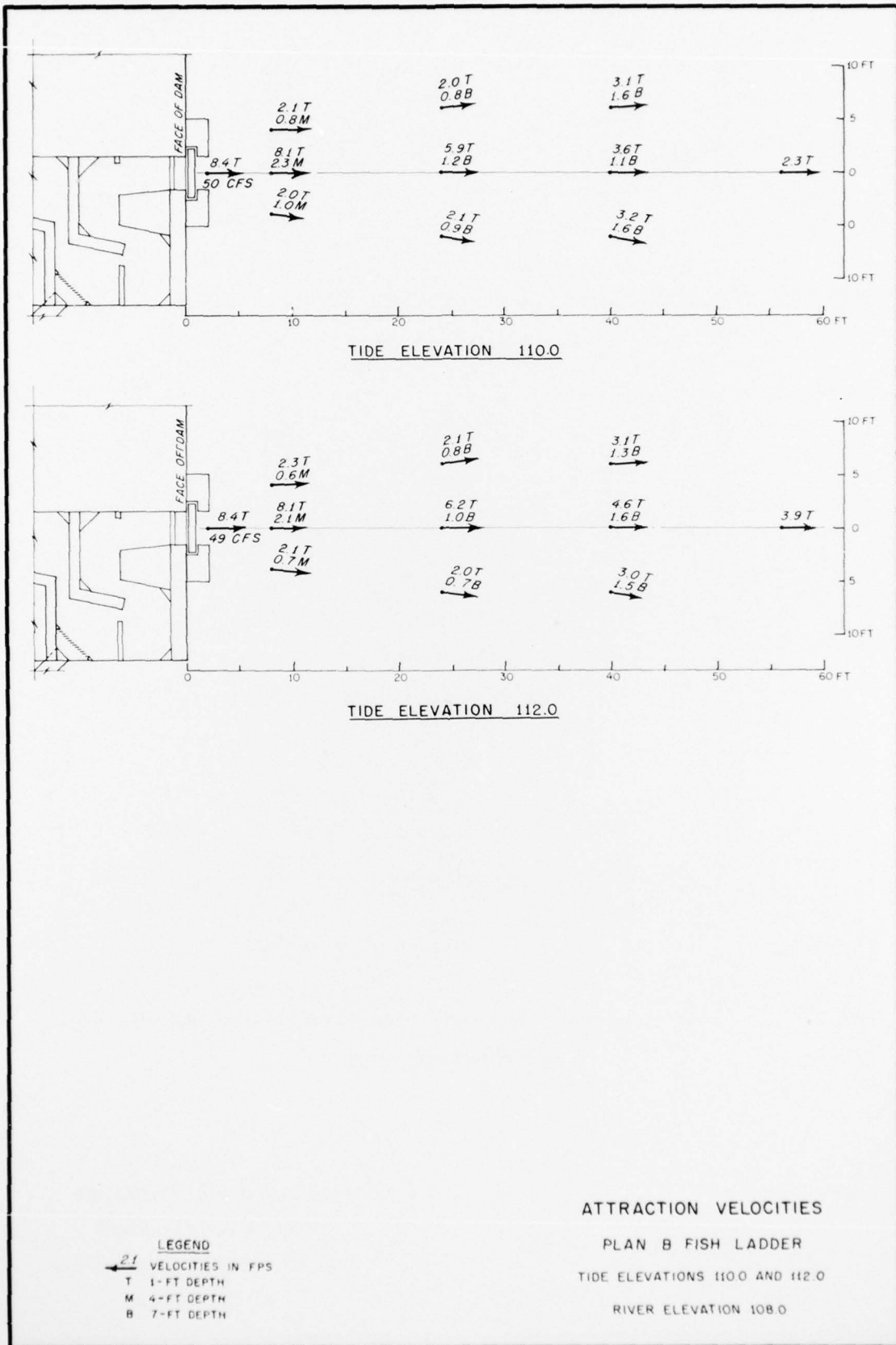

LEGEND
 ← *2t* VELOCITIES IN FPS
 T 1-FT DEPTH
 M 4-FT DEPTH
 B 7-FT DEPTH

ATTRACTION VELOCITIES

PLAN B FISH LADDER
 TIDE ELEVATIONS 110.0 AND 112.0
 RIVER ELEVATION 108.0

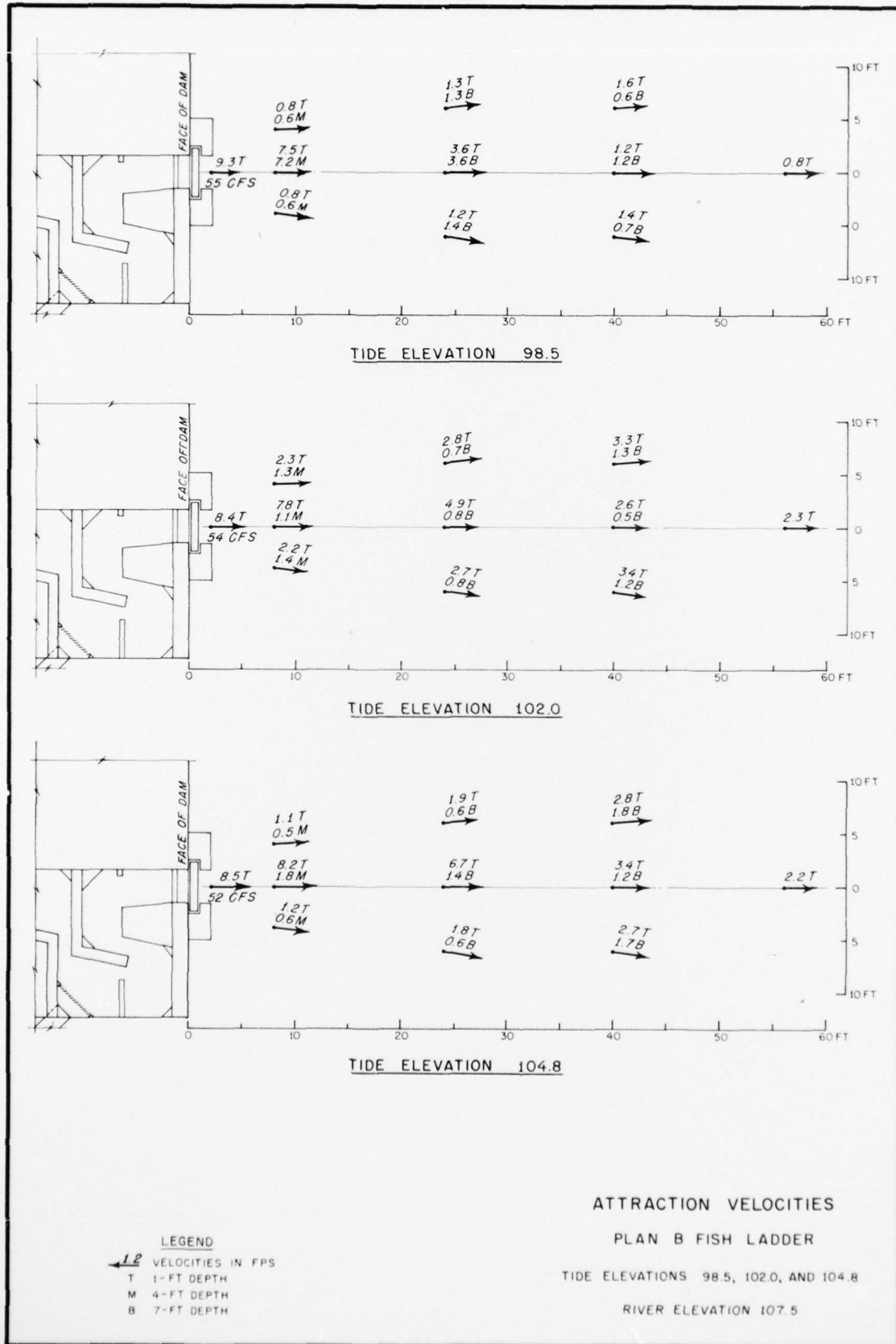

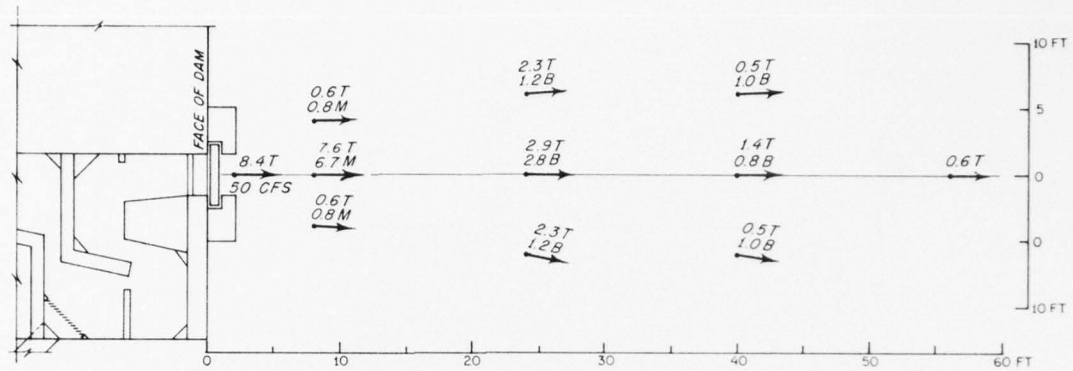

TIDE ELEVATION 98.5

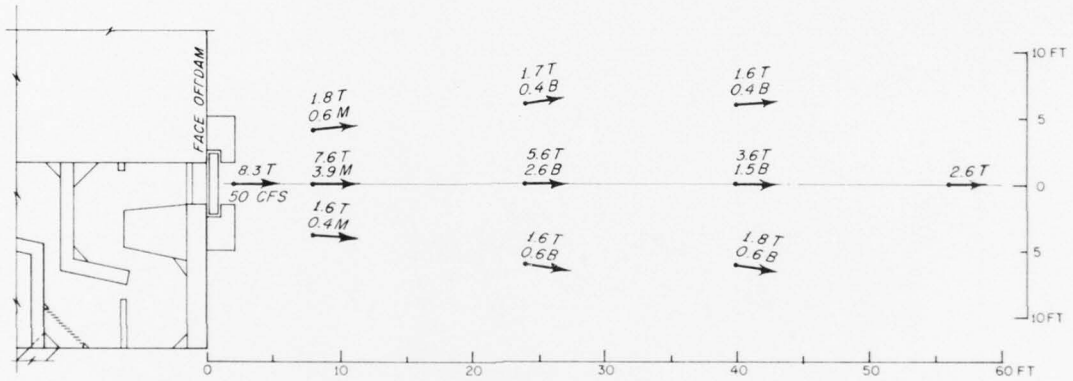

TIDE ELEVATION 102.0

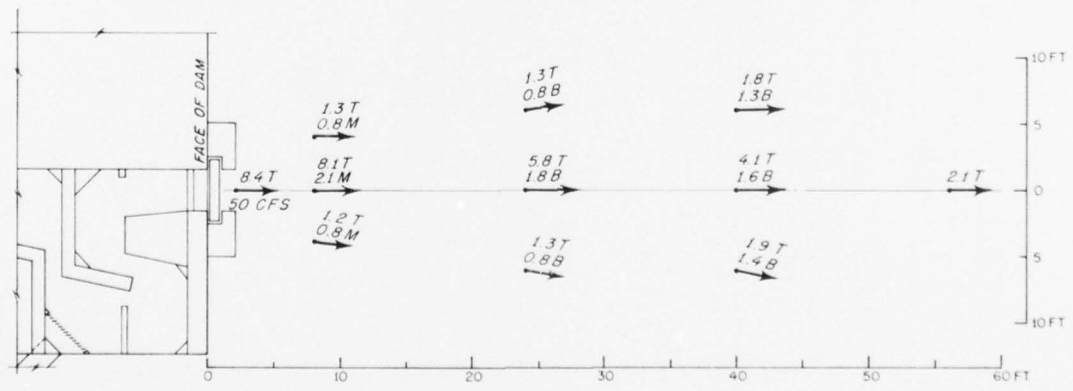

TIDE ELEVATION 106.0

LOW TIDE EXIT CLOSED
POOL 17 BARRIER REMOVED

LEGEND
 VELOCITIES IN FPS
 T 1-FT DEPTH
 M 4-FT DEPTH
 B 7-FT DEPTH

ATTRACTION VELOCITIES
 PLAN B FISH LADDER

TIDE ELEVATIONS 98.5, 102.0, AND 106.0

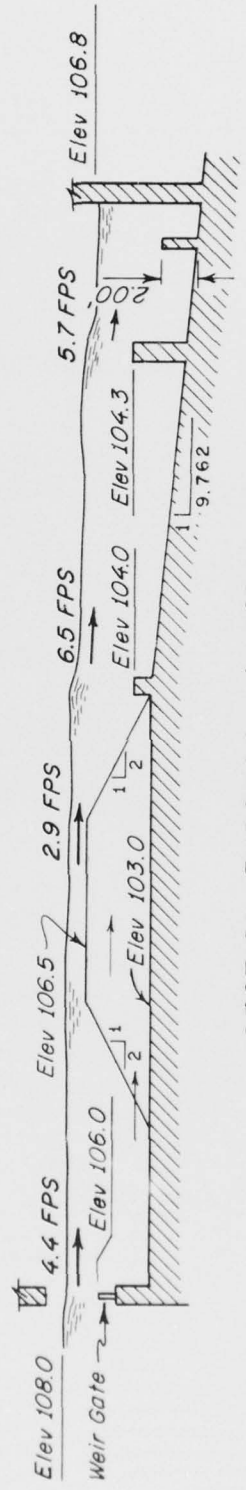
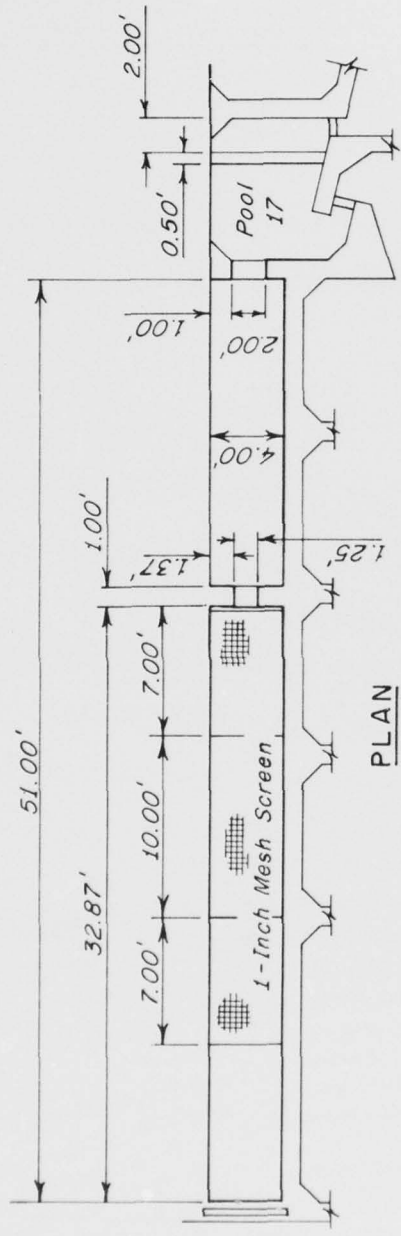

LOW TIDE LADDER
WITH SCREEN BARRIER