

AD-A048 031

AERONAUTICAL RESEARCH LABS MELBOURNE (AUSTRALIA)
TRANSONIC WIND TUNNEL TESTS ON A 1/8TH SCALE MK82 BOMB MODEL.(U)
JUL 77 B D FAIRLIE, L J ROBERTS
ARL/AERO-TM-305

F/G 20/4

UNCLASSIFIED

NL

1 OF 1
AD
A048031

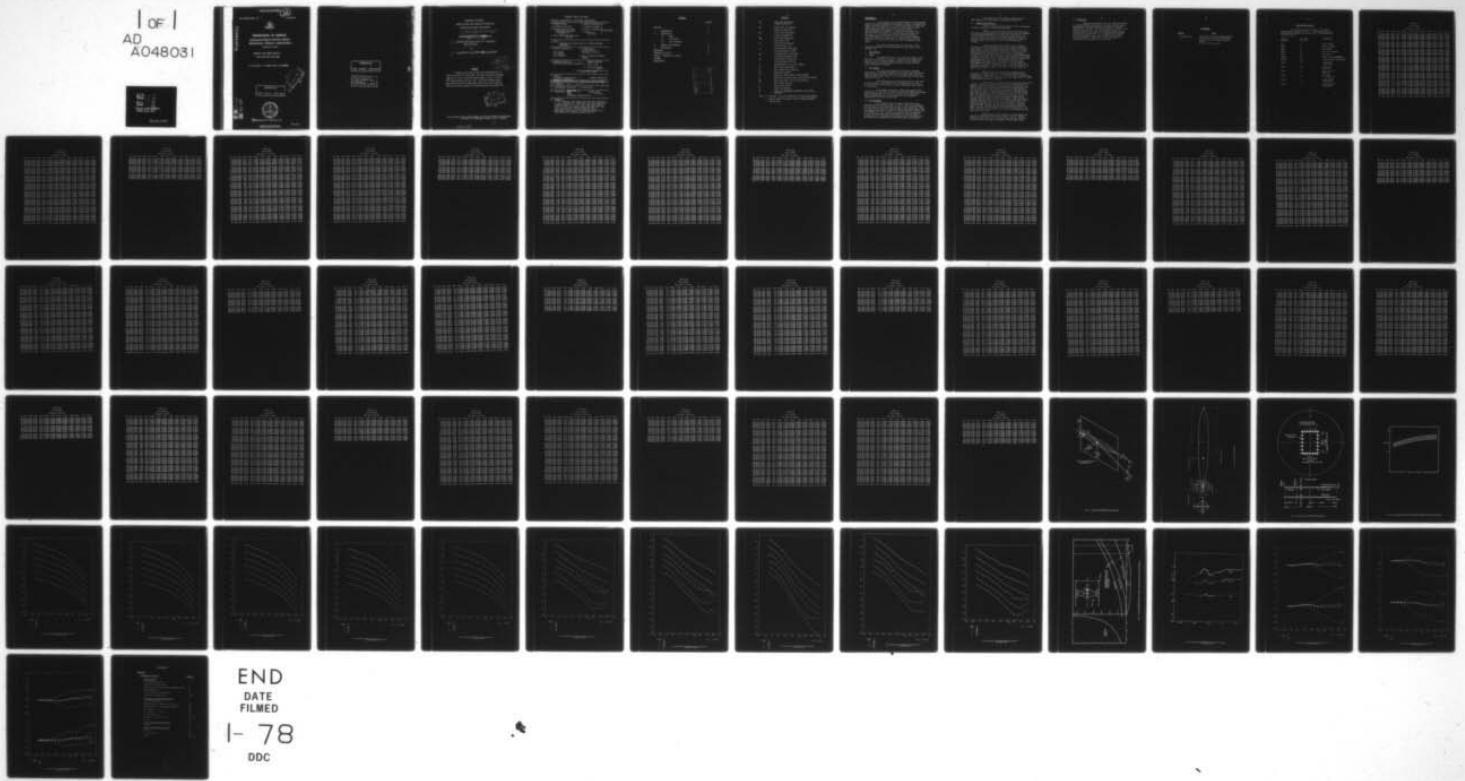

END
DATE
FILMED
1-78
DDC

UNCLASSIFIED

12

ARL Aero/Tech.Memo 305 ✓

AR-000-737



AD A 0 4 8 0 3 1

DEPARTMENT OF DEFENCE
AUSTRALIAN DEFENCE SCIENTIFIC SERVICE
AERONAUTICAL RESEARCH LABORATORIES ✓

MELBOURNE VICTORIA

TRANSONIC WIND TUNNEL TESTS ON A
1/8TH SCALE MK82 BOMB MODEL

B.D. FAIRLIE, L.J. ROBERTS AND R.G. BROADBENT

D D D C
JAN 4 1978
RECEIVED

APPROVED
FOR PUBLIC RELEASE

AD No. _____
DDC FILE COPY



© Commonwealth of Australia 1977

July 1977

UNCLASSIFIED

APPROVED
FOR PUBLIC RELEASE

THE UNITED STATES NATIONAL
TECHNICAL INFORMATION SERVICE
IS AUTHORISED TO
REPRODUCE AND SELL THIS REPORT

DEPARTMENT OF DEFENCE
DEFENCE SCIENCE AND TECHNOLOGY ORGANISATION
AERONAUTICAL RESEARCH LABORATORIES

14 ARL/AERO-TM-305

AERODYNAMICS TECHNICAL MEMORANDUM 305

6 TRANSONIC WIND TUNNEL TESTS ON A 1/8TH SCALE
MK82 BOMB MODEL.

BY

10 B.D. FAIRLIE, L.J. ROBERTS R.G. BROADBENT

11 Jul 77

12 69p.

SUMMARY

Transonic wind tunnel tests have been conducted on a 1/8th scale model of a Mk82 bomb. The tests covered an incidence range of -2° to 28° and a Mach number range of 0.95 to 1.20 for roll angles between -45° and $+45^{\circ}$. The tests indicated that model exhibited static longitudinal stability for all conditions except at low Mach numbers and incidences greater than about 20° .

DDC
RECEIVED
JAN 4 1978
REGISTERED
E

Postal Address: Chief Superintendent, Aeronautical Research Laboratories
Box 4331, P.O. Melbourne, Victoria, 3001. Australia.

008650

Free

DOCUMENT CONTROL DATA SHEET

Security classification of this page UNCLASSIFIED

1. DOCUMENT NUMBERS
a. AR Number: AR-000-737
b. Document Series & Number:
Aerodynamics Technical
Memorandum 305
c. Report Number: ARL/Aero. Tech.
Memo 305

2. SECURITY CLASSIFICATION
a. Complete document: }
b. Title in isolation: } Unclassified
c. Summary in }
isolation: }

3. TITLE:
TRANSONIC WIND TUNNEL TESTS ON A 1/8TH SCALE MK82
BOMB MODEL

4. PERSONAL AUTHOR (S):
B.D. Fairlie
L.J. Roberts
R.G. Broadbent

5. DOCUMENT DATE:
Written June 1977
Published: July 1977

6. TYPE OF REPORT AND PERIOD
COVERED:

7. CORPORATE AUTHOR (S):
Aeronautical Research Laboratories

8. REFERENCE NUMBERS
a. Task: 73/02
b. Sponsoring Agency:
RD 73

9. COST CODE: 549030

10. IMPRINT
Aeronautical Research Lab-
oratories, Melbourne

11. COMPUTER PROGRAM (S)

12. Document Release Limitation: Approved for public release

12-0. OVERSEAS: NO. P.R.1. A B C D E

13. ANNOUNCEMENT LIMITATIONS : No limitations

14. DESCRIPTORS: Wind Tunnel
Tests
Bombs
Aerodynamic Characteristics

15. COSATI CODES:
0101, 2004

16. ABSTRACT:
Transonic wind tunnel tests have been conducted on a 1/8th scale model of a Mk82 bomb. The tests covered an incidence range of -2° to 28° and a Mach number range of 0.95 to 1.20 for roll angles between -45° and +45°. The tests indicated that the model exhibited static longitudinal stability for all conditions except at low Mach numbers and incidences greater than 20°.

CONTENTS

	PAGE NO.
NOTATION	1
1. INTRODUCTION	2
2. TEST DETAILS	2
2.1 Model	
2.2 Wind Tunnel	
2.3 Test Programme	
3. RESULTS AND DISCUSSION	3
4. CONCLUSIONS	4
REFERENCES	5
NOTATION FOR TABLE I	6
TABLE I. Tabulation of Results	
FIGURES	
DISTRIBUTION	

ACCESSION for	
NTIS	W. P. Section <input checked="" type="checkbox"/>
DDC	B. I. Section <input type="checkbox"/>
UNANNOUNCED	<input type="checkbox"/>
JUSTIFICATION _____	
BY _____	
DISTRIBUTION/AVAILABILITY NOTES	
Dist.	SPECIAL
<i>A</i>	

NOTATION

C_D	Drag force coefficient = Drag force/ $\frac{1}{2}\rho V^2S$
C_N	Normal force coefficient = Normal force/ $\frac{1}{2}\rho V^2S$
C_X	Axial force coefficient = Axial force/ $\frac{1}{2}\rho V^2S$
C_{XB}	Base force coefficient = $(p_h - p) S_B / \frac{1}{2}\rho V^2S$
C_Y	Side force coefficient = Side force/ $\frac{1}{2}\rho V^2S$
C_l	Rolling moment coefficient = Rolling moment/ $\frac{1}{2}\rho V^2Sd$
C_m	Pitching moment coefficient = Pitching moment/ $\frac{1}{2}\rho V^2Sd$
C_n	Yawing moment coefficient = Yawing moment/ $\frac{1}{2}\rho V^2 Sd$
d	Body diameter = 34.14 mm (1.344in)
M	Free stream Mach number
P	Free stream static pressure
P_B	Model base pressure
R	Reynolds' number based on body diameter
S	Body cross sectional area = 915.5 mm ² (1.419in ²)
S_B	Model base area = 107.1 mm ² (0.166 in ²)
V	Free stream velocity
ρ	Free stream density
θ	Angle of incidence
ϕ	Model roll angle ($\phi=0$ - suspension point screws uppermost)

- Note: 1. See Fig. 1 for sign conventions for forces and moments.
2. Nominal centre of gravity located 125.42mm (4.938in) from the nose.

INTRODUCTION

At the request of the Weapons Research and Development Wing of the Weapons Research Establishment a series of transonic wind tunnel tests were carried out on a 1/8th scale model of a Mk82 bomb. These tests were conducted in support of the research project "Store Separation from Aircraft" being pursued by the Weapons Research Establishment. To avoid the construction of a new model for these tests, an existing model and balance were supplied by W.R.E. This model had been tested at subsonic and higher supersonic speeds at W.R.E. and the tests reported here were required to investigate the longitudinal and lateral stability of the bomb in the transonic and low supersonic speed range.

The tests reported herein were conducted in the Aeronautical Research Laboratories' transonic wind tunnel during December 1976.

2. TEST DETAILS

2.1 Model

A dimensioned sketch of the 1/8th scale model of the Mk82 bomb is presented in Figure 2. Transition was fixed on the body by a row of discrete roughness spheres. The six component sting mounted strain gauge balance supplied with the model by W.R.E. was used for all tests.

2.2 Wind Tunnel

All tests were conducted in the A.R.L. transonic wind tunnel. The nominal dimensions of the tunnel test section are 813mm by 533mm. For these tests the test section walls were all longitudinally slotted (Fig.3) with an open area ratio at the model location of 10.5%.

The maximum frontal cross-sectional area of the model at zero incidence was 915mm^2 giving a blockage ratio of 0.21%. No corrections for the effects of tunnel interference were applied to the results.

Mach number and dynamic pressure were derived from measurements of the static pressure in the plenum chamber surrounding the test section and of the static pressure in the contraction entry, assuming these to be the static and total pressures respectively of the test section flow.

2.3 Test Programme

Six component force and moment coefficients were measured over an incidence range of $-20^\circ < \theta < 28^\circ$ in 2° increments, for roll angles in the range $-45^\circ < \phi < 45^\circ$ in $7\frac{1}{2}^\circ$ increments. Model attitude was corrected for sting and balance deflections under load. The range of Mach number covered for each attitude was $0.95 < M < 1.20$ in increments of 0.05. In addition, several runs were conducted at zero roll angle and various incidences with fine increments in Mach number to investigate the detailed form of variations with Mach number in the region where shock reflections were apparent.

The variation of test Reynolds number (based on body diameter) with Mach number is presented in Figure 4.

3. RESULTS AND DISCUSSION

Complete results from the present tests are presented in Table I (See Fig. 1 for sign conventions).

Figures 5 and 6 show the variation of normal force coefficient and pitching moment coefficient with angle of incidence for selected representative roll angles ($\phi = -45^\circ, -22.5^\circ, 0^\circ, +22.5^\circ, +45^\circ$). The results show static longitudinal stability under all conditions except at lower Mach numbers and angles of incidence greater than about 20° where some instability is evident.

It was expected that the model would be subject to shock wave reflection interference over a range of supersonic Mach numbers. Since Schlieren observations of the flow in this test section were not possible, an estimate was made of the Mach number range for which this would be the case. The estimate was based on the assumption that wave reflection interference would commence at the Mach number for which a wave from the body shoulder was reflected back to the fin leading edge, and would continue with increasing Mach number until the nose shock reflection fell downstream of the model base. Reflection at the free stream Mach number was assumed, and the position of the nose shock was estimated by Moeckel's ¹ geometric method. As shown in Fig. 7 the estimated Mach number range for the model at zero incidence was from 1.01 to 1.07.

Figure 8 shows the variation of pitching moment coefficient with Mach number for the fine Mach number increment, extended Mach number range runs. It is evident that wave reflection interference is present for Mach numbers in the range 1.00 M 1.08 ; in good agreement with the estimate.

The variation of rolling moment coefficient with angle of incidence is shown in Fig. 9 for $M=0.95$ & 1.20 and selected roll angles. The results for these Mach numbers were chosen since they should be free of interference effects and are representative of all the other tests. Fig. 9 shows a positive rolling moment at zero angle of attack of approximately 0.02 which remains constant under all conditions and can be attributed to the $1\frac{1}{2}^\circ$ cant of the fins. The behaviour of the rolling moment curves are typical of all fin stabilised stores when the fins are not symmetrically disposed about the plane of angle of incidence. When the angle of incidence exceeds about 10° , the fins on the leeward side of the body are influenced appreciably by non uniformity of the flow separating from the body. As the angle of incidence increases beyond 10° this influence becomes very marked and, at some roll angles, results in the annulment of the rolling moment due to fin cant. The effect of fin cant is also seen in the asymmetry of the effects of roll angle.

Similar plots of the variation of yawing moment and side force coefficients are shown in Figs. 10 and 11. Similar remarks to those made for the previous figure are also relevant to the variation with angle of incidence in both these cases.

4. CONCLUSIONS

Transonic wind tunnel tests of a 1/8th scale model of a MK82 bomb have indicated that the model exhibits static longitudinal stability throughout the range of attitudes ($-20^\circ \leq \theta \leq 28^\circ$; $-45^\circ \leq \phi \leq 45^\circ$) and Mach numbers ($0.95 \leq M \leq 1.20$) covered in these tests. The model exhibits a variation of rolling moment at high angles of incidence which is typical of stores on which the fins are not symmetrically disposed about the incidence plane. The influence of roll angle on rolling moment is sufficient at some roll angles to overcome the rolling moment due to fin cant.

REFERENCES

<u>Author</u>	<u>Title</u>
1. Moeckel, W.E.	Approximate Method for Predicting Form and Location of Detached Shock Waves Ahead of Plane or Axially Symmetric Bodies. N.A.C.A. TN 1921, 1949.

NOTATION FOR TABLE I

The following notation refers to the computer generated data listings of TABLE I. Where appropriate, the corresponding notation from the main body of the memorandum is also included.

TABLE I NOTATION	MAIN BODY NOTATION	EXPLANATION
SER	-	Serial number
REYN	R	Reynolds number
MACH	M	Mach number
THETA	θ	Angle of Incidence
RANG	ϕ	Roll Angle
NORMAL	C _N	Normal force coefficient
PITCH	C _m	Pitching moment coefficient
AXIAL	C _x	Axial force coefficient
BASE	C _x B	Base force coefficient
DRAG	C _D	Drag force co- efficient
SIDE F	C _y	Side force coefficient
YAW M	C _n	Yawing moment coefficient
ROLL M	C _l	Rolling moment coefficient

TABLE 1.01

DATA LISTINGS

ROLL ANGLE = -45 DEG.

SER	REYN	MACH	THETA	RANG	NORMAL	PITCH	AXIAL	BASE	DRAG	SIDE F	YAW M	ROLL M
17	0.150	0.949	-2.01	-45.0	0.1063	0.2738	-0.1525	0.0101	0.1662	-0.0037	0.2222	0.0181
18	0.154	0.999	-2.01	-45.0	0.1176	0.1068	-0.1798	0.0064	0.1901	-0.0088	0.2366	0.0189
19	0.157	1.050	-2.02	-45.0	0.1030	0.0111	-0.3129	0.0139	0.3301	-0.0076	0.2452	0.0179
20	0.160	1.099	-2.02	-45.0	0.1132	0.0673	-0.3561	-0.0059	0.3539	-0.0025	0.2122	0.0191
21	0.163	1.152	-2.02	-45.0	0.1236	0.0909	-0.3485	-0.0101	0.3425	0.0042	-0.0299	0.0187
22	0.167	1.202	-2.32	-45.0	0.1406	0.1510	-0.3614	-0.0080	0.3580	-0.0111	0.2424	0.0190
23	0.150	0.950	-0.01	-45.0	-0.0240	-0.0544	-0.1696	0.0064	0.1759	-0.0056	0.2226	0.0186
24	0.154	1.020	-0.01	-45.0	-0.0286	-0.0653	-0.1935	0.0063	0.1998	-0.0107	0.2385	0.0187
25	0.157	1.049	-0.01	-45.0	-0.0208	-0.0554	-0.3050	0.0147	0.3196	-0.0133	0.2387	0.0168
26	0.162	1.098	-0.01	-45.0	-0.0371	-0.1027	-0.3639	-0.0052	0.3586	0.0049	0.2052	0.0189
27	0.163	1.151	-0.01	-45.0	-0.0237	-0.0750	-0.3542	-0.0091	0.3450	0.0036	-0.0250	0.0186
28	0.167	1.198	-0.01	-45.0	-0.0038	-0.0184	-0.3714	-0.0077	0.3637	-0.0110	0.2414	0.0188
29	0.147	0.950	2.01	-45.0	-0.1636	-0.1989	-0.1580	0.0070	0.1706	-0.0128	0.2460	0.0195
30	0.154	0.999	2.01	-45.0	-0.1750	-0.2483	-0.1946	0.0066	0.2072	-0.0108	0.2411	0.0198
31	0.157	1.049	2.02	-45.0	-0.1665	-0.1870	-0.3204	0.0120	0.3380	-0.0131	0.2686	0.0186
32	0.160	1.099	2.02	-45.0	-0.1910	-0.2882	-0.3613	-0.0046	0.3631	-0.0067	0.2190	0.0199
33	0.163	1.148	2.01	-45.0	-0.1855	-0.2594	-0.3487	-0.0096	0.3453	0.0023	-0.0333	0.0206
34	0.167	1.200	2.02	-45.0	-0.1626	-0.1660	-0.3704	-0.0070	0.3688	-0.0173	0.2777	0.0197
35	0.150	0.950	4.03	-45.0	-0.3063	-0.3459	-0.1614	0.0056	0.1880	-0.0068	0.2315	0.0213
36	0.154	1.021	4.03	-45.0	-0.3333	-0.4254	-0.1938	0.0046	0.2212	-0.0122	0.2375	0.0216
37	0.160	1.050	4.03	-45.0	-0.3102	-0.2791	-0.3057	0.0125	0.3392	-0.0149	0.2631	0.0200
38	0.160	1.099	4.03	-45.0	-0.3476	-0.4705	-0.3564	-0.0049	0.3750	-0.0055	0.2133	0.0214
39	0.183	1.149	4.03	-45.0	-0.3415	-0.4214	-0.3530	-0.0110	0.3651	-0.0069	-0.0143	0.0220
40	0.168	1.199	4.03	-45.0	-0.3178	-0.3065	-0.3734	-0.0081	0.3866	-0.0224	0.2991	0.0203
43	0.145	0.947	6.02	-45.0	-0.4573	-0.5085	-0.1502	0.0069	0.2042	-0.0097	0.2131	0.0247
44	0.149	1.000	6.02	-45.0	-0.4905	-0.6027	-0.1835	0.0023	0.2363	-0.0015	0.2180	0.0244
45	0.155	1.051	6.04	-45.0	-0.4798	-0.4615	-0.3175	0.0110	0.3770	-0.0203	0.2610	0.0240
46	0.158	1.122	6.04	-45.0	-0.5047	-0.6230	-0.3605	-0.0050	0.4065	-0.0070	0.2259	0.0246
47	0.162	1.151	6.04	-45.0	-0.5040	-0.5771	-0.3430	-0.0107	0.3833	-0.0008	-0.0222	0.0256
48	0.162	1.200	6.04	-45.0	-0.4778	-0.4281	-0.3644	-0.0089	0.4037	-0.0289	0.1066	0.0228
49	0.147	0.951	8.04	-45.0	-0.6252	-0.6923	-0.1576	0.0039	0.2473	-0.0059	0.2047	0.0275
50	0.152	1.000	8.04	-45.0	-0.6574	-0.7599	-0.1980	0.0027	0.2905	-0.0132	0.2388	0.0275
51	0.155	1.050	8.05	-45.0	-0.6480	-0.6086	-0.3131	0.0109	0.4115	-0.0194	0.2786	0.0278
52	0.158	1.100	8.05	-45.0	-0.6770	-0.7611	-0.3678	-0.0062	0.4527	-0.0100	0.2479	0.0291
53	0.162	1.150	8.05	-45.0	-0.6711	-0.7302	-0.3543	-0.0124	0.4324	0.0035	-0.0448	0.0288
54	0.163	1.199	8.06	-45.0	-0.6492	-0.5613	-0.3878	-0.0123	0.4628	-0.0301	0.1366	0.0263
55	0.147	0.949	10.05	-45.0	-0.8067	-0.8891	-0.1504	0.0039	0.2926	-0.0013	0.2184	0.0306
56	0.152	1.000	10.05	-45.0	-0.8489	-0.9878	-0.1975	0.0037	0.3462	-0.0127	0.2412	0.0317
57	0.155	1.052	10.07	-45.0	-0.8470	-0.8044	-0.3227	0.0098	0.4754	-0.0130	0.2607	0.0311
58	0.158	1.099	10.06	-45.0	-0.8587	-0.9361	-0.3676	-0.0086	0.5035	-0.0033	0.2508	0.0324
59	0.162	1.148	10.07	-45.0	-0.8759	-0.9332	-0.3706	-0.0153	0.5029	-0.0001	-0.0065	0.0309

TABLE 1.01

DATA LISTINGS

ROLL ANGLE = -45 DEG.

SER	REYN	MACH	THETA	RANG	NORMAL	PITCH	AXIAL	BASE	DRAG	SIDE F	YAW M	ROLL M
60	0.163	1.199	10.08	-45.0	-0.0491	-0.7139	-0.3898	-0.0133	0.5192	-0.0284	0.1401	0.0292
61	0.147	0.949	12.07	-45.0	-1.0075	-1.1134	-0.1558	0.0042	0.3670	-0.0035	0.0091	0.0298
62	0.152	0.999	12.07	-45.0	-1.0653	-1.1876	-0.1903	0.0013	0.4101	0.0015	0.0202	0.0298
63	0.155	1.049	12.09	-45.0	-1.0460	-0.9406	-0.3116	0.0098	0.5332	-0.0076	0.0321	0.0288
64	0.160	1.100	12.09	-45.0	-1.0819	-1.1428	-0.3702	-0.0106	0.5781	-0.0073	0.0496	0.0315
65	0.162	1.149	12.09	-45.0	-1.0980	-1.1403	-0.3738	-0.0158	0.5800	0.0066	-0.0240	0.0306
66	0.163	1.201	12.10	-45.0	-1.0614	-0.8724	-0.3874	-0.0138	0.5879	-0.0324	0.1324	0.0269
69	0.144	0.951	14.08	-45.0	-1.2262	-1.3336	-0.1335	0.0051	0.4326	0.0340	-0.0776	0.0213
70	0.145	1.001	14.08	-45.0	-1.2857	-1.3888	-0.1868	0.0000	0.4939	-0.0017	0.0117	0.0223
71	0.152	1.050	14.09	-45.0	-1.3137	-1.2864	-0.3378	0.0099	0.6572	0.0156	-0.0107	0.0208
72	0.154	1.101	14.09	-45.0	-1.3115	-1.3328	-0.3721	-0.0102	0.6705	0.0086	-0.0029	0.0268
73	0.157	1.149	14.11	-45.0	-1.3262	-1.2698	-0.3770	-0.0167	0.6727	0.0140	-0.0728	0.0235
74	0.160	1.201	14.13	-45.0	-1.3043	-1.0051	-0.3950	-0.0147	0.6872	-0.0106	0.0987	0.0224
75	0.145	0.949	16.09	-45.0	-1.4657	-1.5809	-0.1277	0.0026	0.5263	0.0308	-0.1034	0.0114
76	0.149	1.001	16.10	-45.0	-1.5453	-1.6526	-0.1707	-0.0004	0.5922	0.0464	-0.1122	0.0121
77	0.150	1.050	16.14	-45.0	-1.5018	-1.1615	-0.3094	0.0055	0.7198	0.0462	-0.1037	0.0095
78	0.154	1.100	16.12	-45.0	-1.5568	-1.4524	-0.3767	-0.0138	0.7810	0.0374	-0.0536	0.0213
79	0.158	1.151	16.15	-45.0	-1.5767	-1.3806	-0.3705	-0.0192	0.7757	0.0458	-0.1329	0.0175
80	0.160	1.198	16.17	-45.0	-1.5645	-1.0397	-0.3950	-0.0163	0.7993	-0.0046	0.0755	0.0131
81	0.145	0.948	18.11	-45.0	-1.7283	-1.8622	-0.1384	-0.0037	0.6652	0.0482	-0.1131	0.0112
82	0.149	0.997	18.13	-45.0	-1.8396	-1.9455	-0.1522	-0.0055	0.7117	0.0711	-0.2059	0.0082
83	0.152	1.050	18.16	-45.0	-1.8577	-1.5633	-0.3417	0.0022	0.9057	0.0871	-0.2671	0.0079
84	0.157	1.099	18.16	-45.0	-1.8509	-1.6155	-0.3743	-0.0165	0.9169	0.0502	-0.1164	0.0191
85	0.158	1.148	18.19	-45.0	-1.8975	-1.5095	-0.3765	-0.0194	0.9313	0.0547	-0.1698	0.0151
86	0.162	1.201	18.22	-45.0	-1.9147	-1.1442	-0.4006	-0.0161	0.9638	0.0450	-0.0767	0.0116
87	0.144	0.950	20.15	-45.0	-2.0562	-2.0498	-0.1318	-0.0058	0.8263	0.0655	-0.1645	0.0116
88	0.149	1.000	20.17	-45.0	-2.2282	-2.0552	-0.1544	-0.0065	0.9072	0.0955	-0.2590	0.0061
89	0.152	1.049	20.20	-45.0	-2.2357	-1.6582	-0.3299	-0.0026	1.0793	0.0866	-0.2237	0.0048
90	0.157	1.099	20.21	-45.0	-2.2626	-1.8062	-0.3727	-0.0198	1.1129	0.0634	-0.1708	0.0226
91	0.158	1.150	20.24	-45.0	-2.3112	-1.6720	-0.3607	-0.0239	1.1154	0.0753	-0.2424	0.0184
92	0.162	1.198	20.28	-45.0	-2.3530	-1.2592	-0.3855	-0.0186	1.1597	0.0298	-0.0199	0.0162
95	0.147	0.952	22.19	-45.0	-2.4428	-2.0408	-0.1102	-0.0079	1.0173	0.0964	-0.2316	0.0079
96	0.152	1.001	22.23	-45.0	-2.7059	-2.1654	-0.1472	-0.0091	1.1515	0.0821	-0.2021	0.0070
97	0.155	1.050	22.26	-45.0	-2.7026	-1.7407	-0.3142	-0.0112	1.3045	0.0923	-0.2727	0.0040
98	0.158	1.097	22.27	-45.0	-2.7362	-1.9280	-0.3612	-0.0219	1.3509	0.0460	-0.1211	0.0239
99	0.162	1.150	22.31	-45.0	-2.7897	-1.7343	-0.3561	-0.0254	1.3647	0.0637	-0.1875	0.0225
100	0.165	1.198	22.35	-45.0	-2.8262	-1.3104	-0.3742	-0.0209	1.4015	0.0110	-0.0079	0.0198
101	0.147	0.951	24.26	-45.0	-2.9422	-1.9642	-0.1045	-0.0110	1.2941	0.0831	-0.1867	0.0127
102	0.152	1.001	24.30	-45.0	-3.2075	-2.1569	-0.1248	-0.0114	1.4232	0.0851	-0.2118	0.0057
103	0.155	1.049	24.34	-45.0	-3.2007	-1.7358	-0.3190	-0.0098	1.6009	0.0910	-0.2184	0.0035
104	0.162	1.098	24.34	-45.0	-3.2581	-2.0478	-0.3482	-0.0248	1.6377	0.0821	-0.1666	0.0200

TABLE 1.01
DATA LISTINGS

ROLL ANGLE = -45 DEg.

SER	REYN	MACH	THETA	RANG	NORMAL	PITCH	AXIAL	BASE	DRAG	SIDE F	YAW M	ROLL M
105	0.162	1.149	24.38	-45.0	-3.5224	-1.8536	-0.3473	-0.0287	1.6617	0.0863	-0.2176	0.0202
106	0.163	1.200	24.44	-45.0	-3.5728	-1.4535	-0.3714	-0.0230	1.7123	0.0416	-0.1620	0.0213
107	0.147	0.951	26.33	-45.0	-3.5765	-1.8345	-0.0811	-0.0123	1.5590	0.1230	-0.2622	0.0113
108	0.154	1.001	26.37	-45.0	-3.6668	-2.0384	-0.1234	-0.0122	1.7284	0.1330	-0.2716	0.0034
109	0.157	1.051	26.42	-45.0	-3.7253	-1.9064	-0.3275	-0.0163	1.9356	0.1238	-0.2749	0.0016
110	0.160	1.100	26.42	-45.0	-3.7936	-2.1865	-0.3458	-0.0320	1.9689	0.1039	-0.2356	0.0169
111	0.180	1.151	26.46	-45.0	-3.8509	-1.9957	-0.3214	-0.0327	1.9742	0.1390	-0.3293	0.0138
112	0.167	1.198	26.52	-45.0	-3.9095	-1.5974	-0.3468	-0.0261	2.0323	0.0698	-0.1399	0.0176
113	0.163	0.951	28.41	-45.0	-3.9061	-1.6490	-0.0544	-0.0146	1.8934	-0.0360	-0.0462	0.0195
114	0.154	1.002	28.46	-45.0	-4.1659	-1.7933	-0.0997	-0.0131	2.0613	0.0285	-0.1354	0.0145
115	0.157	1.048	28.50	-45.0	-4.2179	-1.6345	-0.2962	-0.0178	2.2573	0.0593	-0.1609	0.0131
116	0.162	1.099	28.50	-45.0	-4.3470	-2.2540	-0.3260	-0.0336	2.3313	0.1246	-0.2715	0.0170
117	0.163	1.149	28.55	-45.0	-4.4075	-2.0713	-0.3027	-0.0342	2.3419	0.1316	-0.2973	0.0187
118	0.167	1.200	28.60	-45.0	-4.4429	-1.7892	-0.3341	-0.0275	2.3954	0.0820	-0.1347	0.0172

TABLE 1.02
DATA LISTINGS

ROLL ANGLE = -37.5 DEG.

SER	REYN	MACH	THETA	RANG	NORMAL	PITCH	AXIAL	BASE	DRAG	SIDE F	YAW M	ROLL M
2	0.139	0.949	-2.01	-37.5	0.1098	0.0765	-0.1401	0.0078	0.1515	-0.0028	0.0192	0.0171
3	0.147	0.999	-2.01	-37.5	0.1178	0.1170	-0.1779	0.0031	0.1850	-0.0001	0.0238	0.0170
4	0.150	1.050	-2.01	-37.5	0.1036	0.0152	-0.3124	0.0144	0.3303	-0.0072	0.0461	0.0167
5	0.154	1.098	-2.01	-37.5	0.1135	0.0659	-0.3524	-0.0073	0.3488	0.0025	0.0207	0.0170
6	0.157	1.149	-2.01	-37.5	0.1230	0.0969	-0.3586	-0.0109	0.3517	0.0133	-0.0036	0.0165
7	0.157	1.200	-2.01	-37.5	0.1420	0.1644	-0.3600	-0.0088	0.3559	-0.0050	0.0489	0.0169
8	0.142	0.951	-0.01	-37.5	-0.0317	-0.0591	-0.1531	0.0061	0.1592	-0.0042	0.0344	0.0167
9	0.145	1.000	-0.01	-37.5	-0.0386	-0.0688	-0.1919	0.0065	0.1984	-0.0024	0.0374	0.0174
10	0.150	1.051	-0.01	-37.5	-0.0312	-0.0790	-0.3065	0.0143	0.3207	-0.0055	0.0512	0.0153
11	0.154	1.100	-0.01	-37.5	-0.0440	-0.1067	-0.3579	-0.0081	0.3497	0.0073	0.0178	0.0170
12	0.157	1.151	-0.01	-37.5	-0.0362	-0.0830	-0.3483	-0.0099	0.3384	0.0130	-0.0216	0.0170
13	0.160	1.198	0.01	-37.5	-0.0110	0.0042	-0.3631	-0.0090	0.3541	-0.0057	0.0448	0.0174
14	0.142	0.950	2.01	-37.5	-0.1621	-0.1967	-0.1554	0.0061	0.1670	-0.0029	0.0444	0.0178
15	0.147	0.999	2.01	-37.5	-0.1796	-0.2403	-0.1911	0.0057	0.2029	-0.0012	0.0373	0.0177
16	0.150	1.049	2.01	-37.5	-0.1701	-0.1698	-0.2941	0.0129	0.3127	-0.0012	0.0626	0.0166
17	0.157	1.099	2.01	-37.5	-0.1917	-0.2947	-0.3538	-0.0053	0.3549	0.0039	0.0136	0.0186
18	0.157	1.149	2.01	-37.5	-0.1869	-0.2545	-0.3566	-0.0113	0.3516	0.0071	0.0032	0.0191
19	0.160	1.201	2.01	-37.5	-0.1670	-0.1595	-0.3726	-0.0083	0.3699	-0.0164	0.0854	0.0187
20	0.142	0.949	4.02	-37.5	-0.3055	-0.3439	-0.1654	0.0042	0.1906	-0.0076	0.0564	0.0191
21	0.149	1.001	4.02	-37.5	-0.3307	-0.4266	-0.1822	0.0043	0.2092	-0.0070	0.0535	0.0197
22	0.152	1.049	4.03	-37.5	-0.3100	-0.2738	-0.3079	0.0131	0.3419	-0.0192	0.0814	0.0185
23	0.157	1.099	4.02	-37.5	-0.3545	-0.4806	-0.3522	-0.0065	0.3696	-0.0082	0.0570	0.0201
24	0.158	1.150	4.02	-37.5	-0.3434	-0.4286	-0.3505	-0.0097	0.3639	-0.0094	0.0275	0.0206
25	0.162	1.201	4.03	-37.5	-0.3261	-0.3095	-0.3712	-0.0097	0.3835	-0.0270	0.1192	0.0192
28	0.142	0.949	6.02	-37.5	-0.4606	-0.5207	-0.1605	0.0058	0.2137	-0.0139	0.0718	0.0228
29	0.147	0.998	6.02	-37.5	-0.4930	-0.6214	-0.1873	0.0031	0.2410	-0.0240	0.1090	0.0222
30	0.150	1.051	6.04	-37.5	-0.4914	-0.4982	-0.3078	0.0120	0.3697	-0.0247	0.1103	0.0234
31	0.154	1.101	6.03	-37.5	-0.5136	-0.6388	-0.3574	-0.0066	0.4028	-0.0238	0.1073	0.0232
32	0.157	1.150	6.04	-37.5	-0.5083	-0.5940	-0.3488	-0.0114	0.3890	-0.0077	0.0299	0.0257
33	0.173	1.198	6.04	-37.5	-0.4825	-0.4617	-0.3726	-0.0119	0.4094	-0.0424	0.1812	0.0221
34	0.142	0.949	8.03	-37.5	-0.6347	-0.7232	-0.1535	0.0043	0.2449	-0.0282	0.1386	0.0244
35	0.147	0.998	8.03	-37.5	-0.6737	-0.8370	-0.1858	0.0023	0.2805	-0.0483	0.1963	0.0251
36	0.150	1.050	8.05	-37.5	-0.6774	-0.7105	-0.3182	0.0126	0.4223	-0.0365	0.1790	0.0271
37	0.154	1.100	8.05	-37.5	-0.6882	-0.8035	-0.3602	-0.0075	0.4455	-0.0394	0.1811	0.0285
38	0.157	1.149	8.05	-37.5	-0.6873	-0.7658	-0.3613	-0.0134	0.4407	-0.0267	0.1198	0.0295
39	0.175	1.200	8.06	-37.5	-0.6587	-0.6011	-0.3780	-0.0129	0.4538	-0.0503	0.2206	0.0271
40	0.144	0.953	10.05	-37.5	-0.8163	-0.9408	-0.1515	0.0032	0.2946	-0.0552	0.2262	0.0283
41	0.149	1.001	10.05	-37.5	-0.8590	-1.0241	-0.1902	-0.0014	0.3358	-0.0685	0.2788	0.0296
42	0.152	1.051	10.07	-37.5	-0.8671	-0.8869	-0.3336	0.0080	0.4878	-0.0552	0.2572	0.0299
43	0.157	1.100	10.07	-37.5	-0.8760	-0.9700	-0.3728	-0.0093	0.5110	-0.0515	0.2386	0.0321
44	0.158	1.149	10.07	-37.5	-0.8802	-0.9442	-0.3590	-0.0156	0.4920	-0.0341	0.1625	0.0316

TABLE 1.02

DATA LISTINGS

ROLL ANGLE = -37.5 DEG.

SER	REYN	MACH	THETA	RANG	NORMAL	PITCH	AXIAL	BASE	DRAG	SIDE F	YAW M	ROLL M
45	0.162	1.201	10.08	-37.5	-0.8544	-0.7426	-0.3918	-0.0140	0.5215	-0.0652	0.3302	0.0292
46	0.145	0.948	12.07	-37.5	-1.0155	-1.1428	-0.1574	0.0021	0.3681	-0.0650	0.2827	0.0250
47	0.149	0.999	12.07	-37.5	-1.0747	-1.2422	-0.1964	-0.0004	0.4164	-0.0840	0.3720	0.0277
48	0.152	1.051	12.08	-37.5	-1.0778	-1.0773	-0.3301	0.0095	0.5576	-0.0626	0.2862	0.0270
49	0.155	1.100	12.08	-37.5	-1.0912	-1.1738	-0.3718	-0.0110	0.5811	-0.0703	0.3274	0.0320
50	0.158	1.148	12.10	-37.5	-1.1016	-1.1469	-0.3777	-0.0179	0.5825	-0.0461	0.2386	0.0282
51	0.162	1.199	12.11	-37.5	-1.0690	-0.8914	-0.3936	-0.0164	0.5929	-0.0818	0.3845	0.0271
54	0.142	0.948	14.07	-37.5	-1.2304	-1.3581	-0.1452	0.0025	0.4424	-0.0493	0.2693	0.0128
55	0.147	0.998	14.08	-37.5	-1.3025	-1.4413	-0.1820	-0.0021	0.4913	-0.0843	0.4313	0.0178
56	0.150	1.050	14.10	-37.5	-1.2891	-1.1574	-0.3210	0.0062	0.6314	-0.0570	0.3123	0.0147
57	0.154	1.101	14.10	-37.5	-1.3186	-1.3620	-0.3691	-0.0135	0.6661	-0.0818	0.3843	0.0239
58	0.157	1.150	14.11	-37.5	-1.3251	-1.2943	-0.3691	-0.0189	0.6626	-0.0660	0.3009	0.0173
59	0.160	1.200	14.12	-37.5	-1.3017	-1.0049	-0.3968	-0.0160	0.6870	-0.1002	0.4687	0.0158
60	0.142	0.952	16.09	-37.5	-1.4724	-1.6125	-0.1342	0.0003	0.5373	-0.0461	0.2577	-0.0052
61	0.147	0.999	16.11	-37.5	-1.5529	-1.6810	-0.1733	-0.0035	0.5939	-0.0676	0.3817	0.0020
62	0.150	1.049	16.13	-37.5	-1.5394	-1.3307	-0.3271	0.0055	0.7470	-0.0398	0.2532	-0.0063
63	0.154	1.100	16.13	-37.5	-1.5709	-1.4966	-0.3802	-0.0155	0.7867	-0.0673	0.3988	0.0088
64	0.157	1.149	16.14	-37.5	-1.5834	-1.4066	-0.3638	-0.0208	0.7697	-0.0723	0.3400	0.0047
65	0.160	1.201	16.17	-37.5	-1.5661	-1.0903	-0.3924	-0.0164	0.7971	-0.0997	0.4859	0.0001
66	0.142	0.949	18.11	-37.5	-1.7356	-1.8735	-0.1333	-0.0036	0.6627	-0.0421	0.2955	-0.0168
67	0.145	1.000	18.13	-37.5	-1.8531	-1.9490	-0.1735	-0.0062	0.7356	-0.0431	0.3157	-0.0143
68	0.150	1.048	18.16	-37.5	-1.8135	-1.3665	-0.3249	-0.0010	0.8730	-0.0179	0.1300	-0.0246
69	0.157	1.099	18.16	-37.5	-1.8723	-1.6679	-0.3677	-0.0173	0.9165	-0.0434	0.3204	-0.0002
70	0.157	1.148	18.18	-37.5	-1.9032	-1.5550	-0.3682	-0.0239	0.9210	-0.0554	0.3280	-0.0090
71	0.160	1.198	18.21	-37.5	-1.9220	-1.2081	-0.3916	-0.0177	0.9560	-0.0945	0.4716	-0.0141
72	0.145	0.950	47.08	-37.5	-2.0392	-2.0345	-0.1215	-0.0068	0.8098	-0.0296	0.2571	-0.0218
73	0.149	0.999	20.17	-37.5	-2.2315	-2.1156	-0.1567	-0.0081	0.9089	-0.0278	0.2661	-0.0202
74	0.152	1.050	20.22	-37.5	-2.2156	-1.5667	-0.3136	-0.0013	1.0585	0.0046	0.1163	-0.0285
75	0.155	1.100	20.21	-37.5	-2.2704	-1.8586	-0.3730	-0.0201	1.1154	-0.0291	0.2318	-0.0018
76	0.158	1.150	20.24	-37.5	-2.3208	-1.6939	-0.3570	-0.0237	1.1155	-0.0419	0.2395	-0.0086
77	0.162	1.200	20.28	-37.5	-2.3662	-1.3004	-0.3826	-0.0192	1.1610	-0.0851	0.4095	-0.0101
80	0.142	0.949	22.19	-37.5	-2.4604	-2.0543	-0.1161	-0.0095	1.0277	-0.0423	0.3119	-0.0298
81	0.147	0.999	22.23	-37.5	-2.7214	-2.2051	-0.1425	-0.0107	1.1512	-0.0435	0.2762	-0.0274
82	0.150	1.050	22.26	-37.5	-2.7274	-1.7751	-0.3278	-0.0053	1.3318	-0.0074	0.0940	-0.0317
83	0.154	1.100	22.26	-37.5	-2.7594	-1.9596	-0.3680	-0.0218	1.3659	-0.0677	0.3032	-0.0018
84	0.157	1.149	22.30	-37.5	-2.8175	-1.7749	-0.3472	-0.0273	1.3651	-0.0764	0.2877	-0.0061
85	0.160	1.201	22.34	-37.5	-2.8408	-1.3727	-0.3790	-0.0219	1.4101	-0.1046	0.4124	-0.0077
86	0.142	0.951	24.25	-37.5	-2.9571	-2.0462	-0.1051	-0.0120	1.2995	-0.0316	0.3405	-0.0428
87	0.147	0.999	24.30	-37.5	-3.2027	-2.1026	-0.1179	-0.0134	1.4129	-0.0638	0.3605	-0.0349
88	0.150	1.050	24.33	-37.5	-3.2269	-1.7484	-0.3107	-0.0159	1.5983	-0.0354	0.1351	-0.0402
89	0.155	1.100	24.34	-37.5	-3.3071	-2.0737	-0.3576	-0.0288	1.6628	-0.0858	0.3057	-0.0064

TABLE 1.02

DATA LISTINGS

ROLL ANGLE = -37.5 DEG.

SER	REYN	MACH	THETA	RANG	NORMAL	PITCH	AXIAL	BASE	DRAG	SIDE F	YAW M	ROLL M
90	0.157	1.149	24.38	-37.0	-3.5556	-1.9520	-0.3339	-0.0312	1.6604	-0.0102	0.1992	-0.0138
91	0.160	1.201	24.41	-37.0	-3.3864	-1.5318	-0.3642	-0.0246	1.7092	-0.0360	0.2507	-0.0139
92	0.145	0.950	26.32	-37.0	-3.3993	-1.8458	-0.0730	-0.0176	1.5568	-0.0931	0.3914	-0.0481
93	0.149	0.999	26.37	-37.0	-3.0789	-1.9457	-0.1116	-0.0153	1.7203	-0.1115	0.4464	-0.0378
94	0.152	1.049	26.41	-37.0	-3.7507	-1.8171	-0.3017	-0.0151	1.9249	-0.0617	0.2179	-0.0397
95	0.157	1.100	26.41	-37.0	-3.0389	-2.1887	-0.3459	-0.0319	1.9891	-0.0783	0.2498	-0.0103
96	0.158	1.152	26.46	-37.0	-3.0830	-1.9779	-0.3152	-0.0338	1.9818	-0.0320	0.2268	-0.0127
97	0.162	1.202	26.50	-37.0	-3.9262	-1.6613	-0.3486	-0.0273	2.0394	-0.0233	0.2488	-0.0153
98	0.144	0.952	28.38	-37.0	-3.0904	-1.9863	-0.0563	-0.0178	1.8828	0.1186	0.0896	-0.0541
99	0.149	1.000	28.44	-37.0	-4.1841	-1.9283	-0.0962	-0.0155	2.0637	0.0723	0.1871	-0.0521
100	0.152	1.050	28.48	-37.0	-4.2840	-2.0032	-0.2903	-0.0176	2.2822	0.1140	-0.0244	-0.0484
101	0.170	1.097	28.49	-37.0	-4.3642	-2.3437	-0.3261	-0.0345	2.3378	0.0477	0.1093	-0.0250
102	0.158	1.152	28.53	-37.0	-4.4077	-2.1337	-0.3032	-0.0365	2.3394	0.0323	0.1488	-0.0247
103	0.163	1.201	28.58	-37.0	-4.4684	-1.8372	-0.3428	-0.0293	2.4128	-0.0276	0.2147	-0.0163

TABLE 1.03
DATA LISTINGS

ROLL ANGLE = -30 DEg.

SER	REYN	MACH	THETA	RANG	NORMAL	PITCH	AXIAL	BASE	DRAG	SIDE F	YAW M	ROLL M
3	0.152	0.951	-2.02	-30.0	0.1088	0.0792	-0.1497	0.0088	0.1622	0.0023	0.0247	0.0191
4	0.158	1.002	-2.02	-30.0	0.1148	0.1045	-0.1828	0.0066	0.1933	0.0051	0.0189	0.0181
5	0.162	1.052	-2.02	-30.0	0.1040	0.0345	-0.3127	0.0123	0.3284	0.0008	0.0415	0.0183
6	0.163	1.098	-2.02	-30.0	0.1136	0.0659	-0.3615	-0.0067	0.3585	0.0081	0.0078	0.0183
7	0.168	1.148	-2.02	-30.0	0.1242	0.1001	-0.3529	-0.0091	0.3479	0.0133	-0.0264	0.0182
8	0.172	1.200	-2.02	-30.0	0.1486	0.1581	-0.3725	-0.0071	0.3704	-0.0102	0.0461	0.0194
9	0.155	0.951	-0.01	-30.0	-0.0240	-0.0617	-0.1648	0.0080	0.1728	0.0012	0.0275	0.0182
10	0.158	0.999	-0.01	-30.0	-0.0254	-0.0669	-0.1811	0.0062	0.1873	-0.0020	0.0316	0.0177
11	0.162	1.052	-0.01	-30.0	-0.0292	-0.0861	-0.3137	0.0094	0.3230	-0.0069	0.0439	0.0182
12	0.165	1.098	-0.01	-30.0	-0.0353	-0.1008	-0.3527	-0.0042	0.3484	0.0083	-0.0042	0.0183
13	0.168	1.149	-0.01	-30.0	-0.0315	-0.0742	-0.3475	-0.0073	0.3402	0.0189	-0.0399	0.0175
14	0.172	1.198	-0.01	-30.0	-0.0229	0.0102	-0.3668	-0.0070	0.3597	-0.0060	0.0423	0.0177
15	0.155	0.951	2.00	-30.0	-0.1620	-0.2047	-0.1739	0.0076	0.1870	-0.0006	0.0292	0.0187
16	0.158	1.000	2.00	-30.0	-0.1751	-0.2383	-0.1864	0.0042	0.1966	-0.0028	0.0421	0.0186
17	0.162	1.050	2.01	-30.0	-0.1690	-0.1930	-0.2955	0.0130	0.3142	-0.0067	0.0527	0.0172
18	0.165	1.102	2.00	-30.0	-0.1889	-0.2913	-0.3534	-0.0039	0.3558	-0.0052	0.0295	0.0183
19	0.172	1.150	2.01	-30.0	-0.1829	-0.2636	-0.3554	-0.0078	0.3538	0.0098	-0.0262	0.0197
20	0.173	1.200	2.01	-30.0	-0.1669	-0.1754	-0.3633	-0.0067	0.3622	-0.0179	0.0633	0.0180
21	0.152	0.950	4.01	-30.0	-0.3062	-0.3669	-0.1591	0.0048	0.1848	-0.0117	0.0575	0.0206
22	0.158	1.000	4.02	-30.0	-0.3378	-0.4498	-0.2004	0.0048	0.2283	-0.0145	0.0847	0.0205
23	0.163	1.048	4.03	-30.0	-0.3147	-0.3020	-0.2940	0.0120	0.3273	-0.0173	0.0855	0.0200
24	0.165	1.100	4.02	-30.0	-0.3602	-0.4797	-0.3566	-0.0042	0.3768	-0.0068	0.0761	0.0211
25	0.172	1.149	4.03	-30.0	-0.3433	-0.4421	-0.3445	-0.0102	0.3575	-0.0025	0.0292	0.0221
26	0.173	1.199	4.03	-30.0	-0.3275	-0.3488	-0.3772	-0.0083	0.3910	-0.0255	0.1249	0.0208
27	0.155	0.949	6.03	-30.0	-0.4686	-0.5646	-0.1607	0.0058	0.2147	-0.0277	0.1327	0.0229
28	0.162	1.001	6.03	-30.0	-0.5033	-0.6693	-0.1921	0.0045	0.2483	-0.0275	0.1469	0.0232
29	0.165	1.051	6.03	-30.0	-0.5025	-0.5713	-0.3244	0.0042	0.3796	-0.0288	0.1471	0.0242
30	0.168	1.100	6.03	-30.0	-0.5227	-0.6881	-0.3623	-0.0071	0.4081	-0.0277	0.1332	0.0238
31	0.172	1.149	6.03	-30.0	-0.5149	-0.6422	-0.3563	-0.0105	0.3980	-0.0266	0.1053	0.0257
32	0.173	1.200	6.04	-30.0	-0.5024	-0.5283	-0.3796	-0.0109	0.4195	-0.0357	0.1671	0.0245
33	0.155	0.950	8.04	-30.0	-0.6495	-0.8131	-0.1483	0.0047	0.2422	-0.0539	0.2303	0.0264
34	0.162	1.001	8.04	-30.0	-0.6917	-0.9269	-0.1910	0.0032	0.2889	-0.0704	0.2950	0.0263
35	0.165	1.051	8.05	-30.0	-0.6897	-0.7835	-0.3147	0.0079	0.4159	-0.0547	0.2534	0.0283
36	0.168	1.099	8.04	-30.0	-0.7102	-0.9062	-0.3628	-0.0079	0.4507	-0.0604	0.2703	0.0289
37	0.173	1.151	8.05	-30.0	-0.7032	-0.8568	-0.3638	-0.0115	0.4473	-0.0501	0.2023	0.0310
38	0.175	1.200	8.06	-30.0	-0.6826	-0.6848	-0.3866	-0.0119	0.4666	-0.0675	0.2902	0.0275
41	0.150	0.949	10.04	-30.0	-0.8419	-1.0480	-0.1452	0.0039	0.2936	-0.0800	0.3575	0.0276
42	0.154	1.001	10.05	-30.0	-0.8941	-1.1486	-0.1890	0.0013	0.3433	-0.1030	0.4386	0.0291
43	0.157	1.048	10.06	-30.0	-0.8710	-0.9215	-0.3130	0.0081	0.4683	-0.0799	0.3306	0.0273
44	0.160	1.100	10.06	-30.0	-0.9005	-1.0973	-0.3642	-0.0087	0.5071	-0.0969	0.4038	0.0329
45	0.163	1.151	10.06	-30.0	-0.9029	-1.0467	-0.3567	-0.0163	0.4929	-0.0644	0.2927	0.0312

TABLE 1.03

DATA LISTINGS

ROLL ANGLE = -30 DEG.

SER	REYN	MACH	THETA	RANG	NORMAL	PITCH	AXIAL	BASE	DRAG	SIDE F	YAW M	ROLL M
46	0.167	1.202	10.07	-30.0	-0.8709	-0.8374	-0.3912	-0.0149	0.5228	-0.0942	0.4403	0.0294
47	0.150	0.948	12.05	-30.0	-1.0560	-1.3014	-0.1502	0.0014	0.3688	-0.1119	0.4905	0.0206
48	0.154	0.999	12.07	-30.0	-1.1035	-1.3753	-0.1958	0.0000	0.4220	-0.1425	0.5971	0.0228
49	0.157	1.049	12.08	-30.0	-1.1122	-1.2228	-0.3447	0.0077	0.5772	-0.1081	0.4885	0.0239
50	0.163	1.101	12.08	-30.0	-1.1185	-1.2969	-0.3795	-0.0117	0.5936	-0.1273	0.5436	0.0295
51	0.163	1.149	12.08	-30.0	-1.1212	-1.2579	-0.3636	-0.0150	0.5754	-0.1059	0.4591	0.0278
52	0.167	1.198	12.10	-30.0	-1.0924	-1.0131	-0.3925	-0.0154	0.5976	-0.1351	0.5995	0.0242
53	0.150	0.952	14.08	-30.0	-1.2651	-1.5036	-0.1468	-0.0029	0.4471	-0.1322	0.5650	0.0035
54	0.154	1.001	14.08	-30.0	-1.3385	-1.5783	-0.1967	-0.0037	0.5127	-0.1731	0.7571	0.0104
55	0.157	1.049	14.10	-30.0	-1.3090	-1.2658	-0.3248	0.0041	0.6379	-0.1371	0.5951	0.0081
56	0.163	1.100	14.09	-30.0	-1.3533	-1.4931	-0.3742	-0.0140	0.6789	-0.1631	0.7107	0.0196
57	0.167	1.149	14.10	-30.0	-1.3602	-1.4329	-0.3709	-0.0182	0.6736	-0.1432	0.6238	0.0138
58	0.168	1.198	14.13	-30.0	-1.3288	-1.1347	-0.3909	-0.0161	0.6877	-0.1798	0.7934	0.0094
59	0.150	0.950	16.10	-30.1	-1.5111	-1.7345	-0.1440	-0.0029	0.5544	-0.1244	0.5984	-0.0195
60	0.157	1.000	16.10	-30.1	-1.5872	-1.8155	-0.1900	-0.0047	0.6182	-0.1712	0.7542	-0.0066
61	0.160	1.050	16.13	-30.1	-1.5565	-1.4081	-0.3425	-0.0013	0.7602	-0.1016	0.4932	-0.0156
62	0.163	1.101	16.12	-30.0	-1.5941	-1.6403	-0.3780	-0.0139	0.7924	-0.1790	0.8034	0.0040
63	0.167	1.149	16.14	-30.1	-1.6134	-1.5680	-0.3546	-0.0172	0.7726	-0.1622	0.7032	-0.0059
64	0.168	1.199	16.16	-30.1	-1.6003	-1.2476	-0.3878	-0.0163	0.8024	-0.1947	0.8535	-0.0067
67	0.147	0.951	18.11	-30.1	-1.7556	-1.9645	-0.1366	0.0003	0.6756	-0.1148	0.5664	-0.0394
68	0.152	1.000	18.12	-30.1	-1.8756	-2.0475	-0.1741	-0.0087	0.7405	-0.1519	0.7418	-0.0226
69	0.152	1.049	18.15	-30.1	-1.8607	-1.6357	-0.3443	0.0003	0.9070	-0.0830	0.4572	-0.0349
70	0.158	1.101	18.15	-30.1	-1.8851	-1.8034	-0.3658	-0.0180	0.9177	-0.1695	0.7540	-0.0095
71	0.162	1.149	18.17	-30.1	-1.9308	-1.7183	-0.3656	-0.0179	0.9324	-0.1502	0.7034	-0.0188
72	0.163	1.199	18.21	-30.1	-1.9553	-1.3766	-0.3848	-0.0164	0.9607	-0.1715	0.7816	-0.0202
73	0.144	0.951	20.13	-30.1	-2.0743	-2.2027	-0.1252	-0.0096	0.8225	-0.0939	0.5147	-0.0476
74	0.152	1.001	20.16	-30.1	-2.2433	-2.2079	-0.1727	-0.0087	0.9271	-0.1181	0.6281	-0.0332
75	0.155	1.050	20.19	-30.1	-2.2506	-1.8222	-0.3389	-0.0023	1.0927	-0.0868	0.4405	-0.0424
76	0.158	1.100	20.20	-30.1	-2.2816	-2.0032	-0.3590	-0.0169	1.1087	-0.1471	0.6933	-0.0165
77	0.158	1.149	20.22	-30.1	-2.3490	-1.8718	-0.3620	-0.0217	1.1313	-0.1429	0.6828	-0.0289
78	0.165	1.198	20.26	-30.1	-2.4013	-1.5022	-0.3767	-0.0183	1.1678	-0.1386	0.7194	-0.0321
79	0.147	0.952	22.17	-30.1	-2.4940	-2.3490	-0.1059	-0.0145	1.0260	-0.0971	0.5416	-0.0535
80	0.149	0.999	22.22	-30.1	-2.7093	-2.3562	-0.1465	-0.0097	1.1510	-0.1481	0.6634	-0.0411
81	0.155	1.052	22.25	-30.1	-2.7230	-1.9688	-0.3340	-0.0069	1.3339	-0.0753	0.4013	-0.0514
82	0.158	1.099	22.25	-30.1	-2.7656	-2.1329	-0.3561	-0.0218	1.3569	-0.1635	0.6787	-0.0198
83	0.162	1.151	22.29	-30.1	-2.8361	-1.9747	-0.3401	-0.0271	1.3653	-0.1453	0.6210	-0.0326
84	0.163	1.200	22.34	-30.1	-2.8930	-1.6077	-0.3731	-0.0205	1.4256	-0.1312	0.6020	-0.0341
85	0.147	0.951	24.24	-30.1	-2.9765	-2.3216	-0.0995	-0.0145	1.2996	-0.1480	0.6743	-0.0660
86	0.152	0.999	24.29	-30.1	-3.2212	-2.2408	-0.1435	-0.0150	1.4422	-0.1940	0.8439	-0.0585
87	0.155	1.049	24.32	-30.1	-3.2608	-2.0134	-0.3338	-0.0114	1.6371	-0.1232	0.5428	-0.0638
88	0.158	1.099	24.34	-30.1	-3.3007	-2.2418	-0.3505	-0.0223	1.6591	-0.1652	0.7244	-0.0320

TABLE 1.03

DATA LISTINGS

ROLL ANGLE = -30 DEG.

SER	REYN	MACH	THETA	RANG	NORMAL	PITCH	AXIAL	BASE	DRAG	SIDE F	YAW M	ROLL M
89	0.163	1.151	24.36	-30.1	-3.3589	-2.1736	-0.3421	-0.0234	1.6757	-0.0980	0.5341	-0.0422
90	0.167	1.200	24.41	-30.1	-3.4159	-1.7438	-0.3669	-0.0226	1.7252	-0.0939	0.5220	-0.0417
91	0.150	0.951	26.31	-30.1	-3.4759	-2.1611	-0.0826	-0.0190	1.5980	-0.2171	0.8681	-0.0847
92	0.154	1.002	26.37	-30.1	-3.7137	-2.0362	-0.1203	-0.0149	1.7441	-0.2399	1.0115	-0.0725
93	0.155	1.048	26.40	-30.1	-3.7797	-2.0259	-0.2938	-0.0152	1.9301	-0.1402	0.6148	-0.0747
94	0.160	1.100	26.41	-30.1	-3.8594	-2.3617	-0.3323	-0.0270	1.9900	-0.1331	0.6245	-0.0443
95	0.162	1.148	26.44	-30.1	-3.9205	-2.2793	-0.3272	-0.0333	2.0089	-0.0611	0.4933	-0.0486
96	0.167	1.198	26.50	-30.1	-3.9548	-1.8383	-0.3442	-0.0278	2.0475	-0.1081	0.5623	-0.0427
97	0.147	0.948	28.38	-30.1	-3.9648	-2.1139	-0.0466	-0.0217	1.9065	-0.1631	0.7297	-0.0895
98	0.154	1.002	28.45	-30.1	-4.2254	-1.9879	-0.0927	-0.0174	2.0789	-0.1767	0.9461	-0.0749
99	0.157	1.049	28.48	-30.1	-4.3327	-2.1136	-0.2816	-0.0176	2.2979	-0.0786	0.5598	-0.0791
100	0.160	1.100	28.48	-30.1	-4.4040	-2.4676	-0.3159	-0.0313	2.3507	-0.0855	0.6181	-0.0570
101	0.163	1.150	28.53	-30.1	-4.4565	-2.3333	-0.2937	-0.0344	2.3560	-0.1173	0.6049	-0.0558
102	0.167	1.200	28.57	-30.1	-4.5034	-2.0173	-0.3246	-0.0295	2.4131	-0.1138	0.6001	-0.0535

TABLE 1.04

DATA LISTINGS

ROLL ANGLE = -22.5 DEG.

SER	REYN	MACH	THETA	RANG	NORMAL	PITCH	AXIAL	BASE	DRAG	SIDE F	YAW M	ROLL M
2	0.152	0.951	-2.01	-22.5	0.1114	0.0697	-0.1588	0.0094	0.1720	0.0029	-0.0160	0.0171
3	0.157	1.033	-2.01	-22.5	0.1228	0.1296	-0.1947	0.0057	0.2046	-0.0016	0.0477	0.0172
4	0.160	1.050	-2.02	-22.5	0.1076	0.0316	-0.3032	0.0122	0.3189	-0.0014	0.0488	0.0158
5	0.163	1.102	-2.01	-22.5	0.1146	0.0640	-0.3597	-0.0065	0.3569	0.0113	-0.0166	0.0171
6	0.168	1.151	-2.01	-22.5	0.1235	0.0905	-0.3467	-0.0109	0.3399	0.0165	-0.0313	0.0164
7	0.168	1.198	-2.01	-22.5	0.1467	0.1698	-0.3638	-0.0083	0.3604	-0.0071	0.0657	0.0169
8	0.152	0.951	-0.01	-22.5	-0.0275	-0.0689	-0.1578	0.0081	0.1659	-0.0016	0.0290	0.0155
9	0.158	1.003	-0.01	-22.5	-0.0323	-0.0759	-0.2003	0.0073	0.2075	0.0092	0.0125	0.0170
10	0.163	1.049	-0.01	-22.5	-0.0351	-0.0879	-0.3116	0.0146	0.3261	-0.0045	0.0346	0.0163
11	0.165	1.102	-0.01	-22.5	-0.0425	-0.1195	-0.3571	-0.0058	0.3513	0.0132	0.0028	0.0169
12	0.168	1.148	-0.01	-22.5	-0.0292	-0.0752	-0.3508	-0.0102	0.3405	0.0012	-0.0194	0.0164
13	0.172	1.198	-0.01	-22.5	-0.0084	0.0034	-0.3588	-0.0082	0.3505	-0.0154	0.0928	0.0165
14	0.155	0.950	2.00	-22.5	-0.1628	-0.2098	-0.1601	0.0063	0.1719	-0.0040	0.0339	0.0177
15	0.158	0.999	2.01	-22.5	-0.1788	-0.2576	-0.1911	0.0066	0.2038	-0.0031	0.0436	0.0173
16	0.162	1.051	2.01	-22.5	-0.1774	-0.2376	-0.3366	0.0141	0.3566	-0.0060	0.0635	0.0167
17	0.165	1.099	2.01	-22.5	-0.1929	-0.2940	-0.3506	-0.0036	0.3535	0.0072	0.0135	0.0173
18	0.168	1.150	2.00	-22.5	-0.1848	-0.2623	-0.3485	-0.0087	0.3460	0.0048	-0.0173	0.0186
19	0.173	1.201	2.01	-22.5	-0.1647	-0.1693	-0.3704	-0.0084	0.3676	-0.0160	0.0928	0.0177
20	0.155	0.950	4.02	-22.5	-0.3142	-0.3918	-0.1613	0.0080	0.1908	-0.0124	0.0701	0.0192
21	0.158	1.001	4.01	-22.5	-0.3417	-0.4758	-0.1918	0.0042	0.2194	-0.0098	0.0659	0.0192
22	0.162	1.050	4.02	-22.5	-0.3370	-0.4088	-0.3282	0.0130	0.3640	-0.0210	0.0881	0.0207
23	0.165	1.099	4.02	-22.5	-0.3631	-0.5233	-0.3501	-0.0060	0.3686	-0.0101	0.0701	0.0206
24	0.172	1.149	4.02	-22.5	-0.3535	-0.4732	-0.3509	-0.0109	0.3640	-0.0053	0.0035	0.0217
25	0.173	1.200	4.02	-22.5	-0.3340	-0.3669	-0.3786	-0.0096	0.3914	-0.0282	0.1335	0.0204
28	0.168	0.950	6.02	-22.5	-0.4814	-0.6417	-0.1579	0.0047	0.2122	-0.0347	0.1510	0.0232
29	0.154	0.998	6.02	-22.5	-0.5238	-0.7432	-0.1825	0.0027	0.2391	-0.0333	0.1799	0.0221
30	0.160	1.050	6.02	-22.5	-0.5236	-0.6434	-0.3270	0.0110	0.3911	-0.0279	0.1439	0.0239
31	0.163	1.099	6.02	-22.5	-0.5367	-0.7540	-0.3531	-0.0084	0.3991	-0.0307	0.1617	0.0225
32	0.183	1.149	6.02	-22.5	-0.5273	-0.7180	-0.3460	-0.0125	0.3870	-0.0218	0.0883	0.0251
33	0.168	1.199	6.04	-22.5	-0.5077	-0.5715	-0.3711	-0.0121	0.4103	-0.0437	0.2111	0.0223
34	0.165	0.950	8.03	-22.5	-0.6766	-0.9421	-0.1563	0.0043	0.2535	-0.0596	0.2464	0.0242
35	0.157	0.998	8.03	-22.5	-0.7189	-1.0490	-0.1973	0.0006	0.2963	-0.0736	0.2992	0.0232
36	0.160	1.049	8.04	-22.5	-0.7194	-0.9374	-0.3299	0.0064	0.4335	-0.0590	0.2609	0.0257
37	0.163	1.101	8.04	-22.5	-0.7345	-1.0121	-0.3874	-0.0101	0.4762	-0.0629	0.3070	0.0269
38	0.168	1.152	8.04	-22.5	-0.7301	-0.9712	-0.3629	-0.0153	0.4463	-0.0454	0.2069	0.0273
39	0.168	1.198	8.05	-22.5	-0.7043	-0.7987	-0.3981	-0.0153	0.4776	-0.0788	0.3350	0.0250
40	0.152	0.951	10.04	-22.5	-0.0795	-1.2289	-0.1650	0.0003	0.3160	-0.0992	0.4238	0.0226
41	0.172	0.998	10.04	-22.5	-0.9289	-1.3386	-0.2041	-0.0017	0.3612	-0.1122	0.4713	0.0250
42	0.162	1.050	10.05	-22.5	-0.9258	-1.1600	-0.3405	0.0085	0.5052	-0.0805	0.3861	0.0245
43	0.165	1.100	10.05	-22.5	-0.9410	-1.2639	-0.3829	-0.0121	0.5293	-0.1047	0.4720	0.0275
44	0.168	1.150	10.06	-22.5	-0.9333	-1.2073	-0.3662	-0.0174	0.5064	-0.0892	0.3719	0.0301

TABLE 1.04

DATA LISTINGS

ROLL ANGLE = -22,5 DEG.

SER	REYN	MACH	THETA	RANG	NORMAL	PITCH	AXIAL	BASE	DRAG	SIDE F	YAW M	ROLL M
45	0.172	1.199	10.07	-22,5	-0.9173	-0.9855	-0.4055	-0.0159	0.5427	-0.1096	0.4998	0.0268
46	0.155	0.951	12.05	-22,5	-1.0898	-1.4844	-0.1595	-0.0018	0.3817	-0.1533	0.6370	0.0148
47	0.158	0.999	12.06	-22,5	-1.1460	-1.5637	-0.1977	-0.0043	0.4284	-0.1727	0.7257	0.0179
48	0.162	1.049	12.07	-22,5	-1.1341	-1.3528	-0.3379	0.0040	0.5716	-0.1258	0.5183	0.0170
49	0.165	1.099	12.07	-22,5	-1.1609	-1.4936	-0.3877	-0.0129	0.6092	-0.1588	0.6987	0.0252
50	0.172	1.149	12.08	-22,5	-1.1603	-1.4270	-0.3746	-0.0187	0.5908	-0.1317	0.6009	0.0232
51	0.173	1.201	12.10	-22,5	-1.1345	-1.1954	-0.3920	-0.0166	0.6047	-0.1557	0.6924	0.0216
52	0.155	0.951	14.07	-22,0	-1.5221	-1.7291	-0.1572	-0.0045	0.4695	-0.1681	0.7295	-0.0053
53	0.175	0.999	14.07	-22,5	-1.3978	-1.8346	-0.1949	-0.0085	0.5207	-0.2063	0.9032	0.0029
54	0.165	1.050	14.09	-22,5	-1.3788	-1.5618	-0.3470	0.0027	0.6749	-0.1732	0.7382	0.0005
55	0.165	1.100	14.10	-22,5	-1.4082	-1.7157	-0.3817	-0.0148	0.6986	-0.2058	0.9228	0.0107
56	0.172	1.149	14.11	-22,5	-1.4031	-1.6473	-0.3743	-0.0193	0.6860	-0.1830	0.7925	0.0070
57	0.173	1.198	14.12	-22,5	-1.3746	-1.3709	-0.4010	-0.0165	0.7081	-0.2134	0.9064	0.0068
58	0.155	0.951	16.09	-22,0	-1.5446	-1.9342	-0.1479	-0.0072	0.5632	-0.1527	0.7398	-0.0318
59	0.162	1.000	16.10	-22,0	-1.6534	-2.0802	-0.1918	-0.0101	0.6331	-0.2151	0.9847	-0.0120
60	0.165	1.051	16.12	-22,0	-1.6397	-1.7977	-0.3540	-0.0007	0.7947	-0.1922	0.8508	-0.0184
61	0.168	1.101	16.12	-22,0	-1.6518	-1.8918	-0.3761	-0.0170	0.8036	-0.2435	1.0260	-0.0033
62	0.173	1.150	16.13	-22,0	-1.6659	-1.8207	-0.3675	-0.0222	0.7946	-0.2019	0.8762	-0.0073
63	0.176	1.199	16.16	-22,0	-1.6536	-1.5026	-0.4021	-0.0179	0.8292	-0.2263	0.9978	-0.0089
66	0.147	0.951	18.09	-22,0	-1.8006	-2.2258	-0.1277	-0.0092	0.6720	-0.1292	0.6751	-0.0502
67	0.152	0.999	18.11	-22,0	-1.9522	-2.3831	-0.1699	-0.0114	0.7575	-0.1894	0.8814	-0.0272
68	0.157	1.052	18.14	-22,0	-1.9334	-2.0176	-0.3648	-0.0046	0.9442	-0.1695	0.7974	-0.0314
69	0.175	1.101	18.14	-22,0	-1.9501	-2.0823	-0.3674	-0.0190	0.9383	-0.2158	0.9843	-0.0148
70	0.163	1.152	18.16	-22,0	-1.9907	-1.9888	-0.3603	-0.0229	0.9411	-0.1874	0.8520	-0.0204
71	0.180	1.198	18.19	-22,0	-2.0227	-1.6739	-0.3935	-0.0188	0.9875	-0.2009	0.9337	-0.0212
72	0.150	0.950	20.12	-22,0	-2.1349	-2.5161	-0.1225	-0.0141	0.8363	-0.1376	0.6452	-0.0557
73	0.154	1.000	20.15	-22,0	-2.3016	-2.5417	-0.1544	-0.0147	0.9241	-0.1817	0.8075	-0.0373
74	0.172	1.050	20.19	-22,0	-2.3067	-2.1441	-0.3507	-0.0088	1.1169	-0.1361	0.6356	-0.0423
75	0.162	1.098	20.18	-22,0	-2.3406	-2.3190	-0.3637	-0.0201	1.1302	-0.1848	0.8800	-0.0235
76	0.163	1.149	20.21	-22,0	-2.4137	-2.1777	-0.3592	-0.0234	1.1492	-0.1575	0.8007	-0.0314
77	0.167	1.200	20.26	-22,0	-2.4710	-1.8179	-0.3770	-0.0188	1.1915	-0.1996	0.9079	-0.0333
78	0.150	0.952	22.16	-22,0	-2.5544	-2.7635	-0.1173	-0.0114	1.0617	-0.1208	0.6034	-0.0630
79	0.154	1.002	22.20	-22,0	-2.7573	-2.6576	-0.1556	-0.0155	1.1719	-0.1635	0.8129	-0.0494
80	0.157	1.050	22.24	-22,0	-2.7606	-2.2598	-0.3251	-0.0119	1.3349	-0.1197	0.6550	-0.0537
81	0.160	1.100	22.25	-22,0	-2.7923	-2.4376	-0.3636	-0.0214	1.3740	-0.1626	0.8274	-0.0302
82	0.163	1.148	22.27	-22,0	-2.8907	-2.3645	-0.3477	-0.0252	1.3943	-0.1311	0.7221	-0.0436
83	0.167	1.198	22.33	-22,0	-2.9485	-1.9400	-0.3760	-0.0204	1.4491	-0.1789	0.8631	-0.0441
84	0.150	0.950	24.22	-22,0	-3.0460	-2.9280	-0.0864	-0.0149	1.3147	-0.0665	0.5320	-0.0788
85	0.154	1.000	24.27	-22,0	-3.2650	-2.7156	-0.1369	-0.0157	1.4526	-0.1714	0.9154	-0.0602
86	0.158	1.047	24.31	-22,0	-3.2633	-2.2728	-0.3067	-0.0156	1.6089	-0.1252	0.6737	-0.0764
87	0.163	1.102	24.32	-22,0	-3.3258	-2.6345	-0.3508	-0.0248	1.6666	-0.0984	0.7180	-0.0424

TABLE 1.04
DATA LISTINGS

ROLL ANGLE = -22,5 DEG.

SER	REYN	MACH	THETA	RANG	NORMAL	PITCH	AXIAL	BASE	DRAG	SIDE F	YAW M	ROLL M
88	0.167	1.149	24.36	-22.0	-3.4082	-2.4724	-0.3451	-0.0264	1.6957	-0.1218	0.7244	-0.0527
89	0.168	1.198	24.40	-22.0	-3.4833	-2.1180	-0.3697	-0.0224	1.7554	-0.1148	0.6920	-0.0562
90	0.150	0.950	26.29	-22.0	-3.5512	-2.7682	-0.0608	-0.0172	1.6122	-0.1673	0.7778	-0.0989
91	0.157	1.000	26.35	-22.0	-3.7863	-2.5978	-0.1119	-0.0189	1.7642	-0.1929	1.0331	-0.0801
92	0.160	1.050	26.39	-22.0	-3.8375	-2.4798	-0.3081	-0.0210	1.9627	-0.1722	0.8691	-0.0903
93	0.163	1.098	26.40	-22.0	-3.9269	-2.7904	-0.3296	-0.0273	2.0168	-0.1386	0.8147	-0.0634
94	0.167	1.149	26.43	-22.0	-3.9763	-2.6640	-0.3113	-0.0288	2.0230	-0.0759	0.6566	-0.0671
95	0.168	1.199	26.48	-22.0	-4.0286	-2.2456	-0.3458	-0.0241	2.0847	-0.1112	0.7115	-0.0677
96	0.152	0.950	28.36	-22.0	-4.0846	-2.8589	-0.0321	-0.0178	1.9530	-0.0547	0.5956	-0.1054
97	0.172	1.001	28.43	-22.0	-4.3020	-2.5532	-0.0793	-0.0181	2.1021	-0.1106	0.8910	-0.0919
98	0.162	1.051	28.46	-22.0	-4.4043	-2.6852	-0.2901	-0.0199	2.3365	-0.0486	0.6272	-0.1027
99	0.165	1.100	28.47	-22.0	-4.4797	-2.9392	-0.3053	-0.0309	2.3772	-0.0962	0.7771	-0.0775
100	0.168	1.152	28.52	-22.0	-4.5307	-2.7100	-0.2954	-0.0319	2.3949	-0.1343	0.8424	-0.0762
102	0.172	1.199	28.57	-22.0	-4.5815	-2.4281	-0.3224	-0.0275	2.4499	-0.1086	0.7457	-0.0761

TABLE 1.05
DATA LISTINGS

ROLL ANGLE = -15 DEG.

SER	REYN	MACH	THETA	RANG	NORMAL	PITCH	AXIAL	BASE	DRAG	SIDE F	YAW M	ROLL M
2	0.155	0.951	-2.02	-15.0	0.1096	0.0846	-0.1548	0.0091	0.1676	0.0096	-0.0105	0.0180
3	0.158	1.001	-2.02	-15.0	0.1210	0.1204	-0.1851	0.0053	0.1944	0.0058	-0.0005	0.0184
4	0.163	1.049	-2.02	-15.0	0.1112	0.0388	-0.3060	0.0129	0.3225	-0.0115	0.0392	0.0171
5	0.165	1.098	-2.02	-15.0	0.1143	0.0649	-0.3559	-0.0052	0.3545	0.0143	-0.0336	0.0177
6	0.168	1.149	-2.02	-15.0	0.1266	0.1045	-0.3480	-0.0087	0.3435	0.0093	-0.0566	0.0179
7	0.172	1.199	-2.02	-15.0	0.1458	0.1607	-0.3695	-0.0079	0.3665	-0.0044	0.0220	0.0187
8	0.155	0.952	-0.01	-15.0	-0.0242	-0.0548	-0.1627	0.0076	0.1703	0.0074	0.0142	0.0173
9	0.158	1.002	-0.01	-15.0	-0.0272	-0.0655	-0.2046	0.0059	0.2104	0.0051	0.0066	0.0176
10	0.163	1.049	-0.01	-15.0	-0.0314	-0.0845	-0.3037	0.0109	0.3145	0.0089	0.0172	0.0168
11	0.168	1.099	-0.01	-15.0	-0.0341	-0.0974	-0.3525	-0.0042	0.3483	0.0103	0.0073	0.0177
12	0.172	1.150	-0.01	-15.0	-0.0288	-0.0788	-0.3525	-0.0078	0.3447	0.0190	-0.0518	0.0172
13	0.173	1.201	0.01	-15.0	-0.0075	0.0009	-0.3659	-0.0072	0.3587	-0.0140	0.0809	0.0185
14	0.155	0.950	2.01	-15.0	-0.1650	-0.2110	-0.1590	0.0062	0.1708	0.0012	0.0133	0.0186
15	0.162	1.002	2.00	-15.0	-0.1816	-0.2620	-0.1999	0.0058	0.2119	0.0023	0.0263	0.0185
16	0.165	1.052	2.01	-15.0	-0.1806	-0.2418	-0.3177	0.0132	0.3370	-0.0071	0.0399	0.0183
17	0.168	1.099	2.00	-15.0	-0.1933	-0.3010	-0.3601	-0.0033	0.3633	0.0048	0.0076	0.0185
18	0.172	1.148	2.01	-15.0	-0.1859	-0.2722	-0.3432	-0.0091	0.3403	0.0146	-0.0549	0.0192
19	0.173	1.199	2.01	-15.0	-0.1619	-0.1706	-0.3739	-0.0074	0.3718	-0.0198	0.0762	0.0177
20	0.172	0.948	4.01	-15.0	-0.3182	-0.4068	-0.1511	0.0054	0.1784	-0.0057	0.0496	0.0209
21	0.162	1.002	4.01	-15.0	-0.3500	-0.5070	-0.2066	0.0032	0.2337	-0.0136	0.0633	0.0204
22	0.183	1.049	4.02	-15.0	-0.3309	-0.3643	-0.3058	0.0076	0.3358	-0.0136	0.0524	0.0210
23	0.188	1.102	4.02	-15.0	-0.3604	-0.5068	-0.3563	-0.0047	0.3759	-0.0093	0.0388	0.0221
24	0.173	1.148	4.02	-15.0	-0.3575	-0.4964	-0.3520	-0.0099	0.3663	-0.0029	0.0036	0.0229
25	0.195	1.202	4.02	-15.0	-0.3414	-0.3936	-0.3835	-0.0106	0.3959	-0.0224	0.0957	0.0217
26	0.158	0.949	6.02	-15.0	-0.4984	-0.6958	-0.1618	0.0037	0.2169	-0.0219	0.1126	0.0245
27	0.162	0.999	6.02	-15.0	-0.5386	-0.8128	-0.1937	0.0028	0.2519	-0.0417	0.1544	0.0248
28	0.165	1.048	6.03	-15.0	-0.5254	-0.6655	-0.3181	0.0069	0.3784	-0.0266	0.1253	0.0256
29	0.168	1.099	6.03	-15.0	-0.5542	-0.8231	-0.3699	-0.0084	0.4176	-0.0355	0.1448	0.0246
30	0.173	1.151	6.03	-15.0	-0.5430	-0.7667	-0.3426	-0.0128	0.3849	-0.0144	0.0425	0.0265
31	0.175	1.199	6.04	-15.0	-0.5243	-0.6306	-0.3917	-0.0137	0.4309	-0.0454	0.1743	0.0252
32	0.158	0.948	8.03	-15.0	-0.7057	-1.0530	-0.1586	0.0013	0.2569	-0.0526	0.1970	0.0268
33	0.162	1.000	8.03	-15.0	-0.7525	-1.1670	-0.2034	0.0025	0.3090	-0.0640	0.2645	0.0259
34	0.167	1.050	8.04	-15.0	-0.7402	-1.0072	-0.3276	0.0045	0.4323	-0.0507	0.1914	0.0273
35	0.188	1.099	8.04	-15.0	-0.7656	-1.1391	-0.3701	-0.0101	0.4634	-0.0592	0.2442	0.0268
36	0.190	1.151	8.04	-15.0	-0.7525	-1.0790	-0.3640	-0.0152	0.4506	-0.0452	0.1405	0.0301
37	0.195	1.198	8.05	-15.0	-0.7320	-0.9029	-0.3989	-0.0165	0.4811	-0.0619	0.2655	0.0276
41	0.147	0.952	10.03	-15.0	-0.9215	-1.3818	-0.1474	0.0010	0.3067	-0.0726	0.3107	0.0234
42	0.152	1.001	10.04	-15.0	-0.9738	-1.4861	-0.1943	-0.0014	0.3596	-0.1022	0.3969	0.0269
43	0.155	1.049	10.05	-15.0	-0.9718	-1.3544	-0.3399	0.0075	0.5115	-0.0807	0.3195	0.0270
44	0.175	1.102	10.04	-15.0	-0.9802	-1.4244	-0.3694	-0.0088	0.5260	-0.0978	0.4054	0.0281
45	0.163	1.152	10.05	-15.0	-0.9754	-1.3584	-0.3665	-0.0183	0.5130	-0.0624	0.2846	0.0301

TABLE 1.05
DATA LISTINGS

ROLL ANGLE = -15 DEG.

SER	REYN	MACH	THETA	RANG	NORMAL	PITCH	AXIAL	BASE	DRAG	SIDE F	YAW M	ROLL M
46	0.180	1.198	10.06	-15.0	-0.9485	-1.1390	-0.3939	-0.0154	0.5384	-0.0996	0.4220	0.0281
47	0.150	0.952	12.04	-15.0	-1.1511	-1.7093	-0.1592	-0.0047	0.3912	-0.1345	0.5533	0.0140
48	0.152	0.999	12.05	-15.0	-1.2079	-1.7967	-0.1923	-0.0018	0.4385	-0.1269	0.5310	0.0188
49	0.157	1.049	12.06	-15.0	-1.1948	-1.5764	-0.3470	0.0009	0.5899	-0.1133	0.4512	0.0158
50	0.160	1.101	12.06	-15.0	-1.2172	-1.6993	-0.3820	-0.0152	0.6130	-0.1496	0.6135	0.0225
51	0.163	1.149	12.07	-15.0	-1.2088	-1.6343	-0.3725	-0.0179	0.5995	-0.1204	0.4979	0.0245
52	0.167	1.200	12.08	-15.0	-1.1784	-1.3739	-0.3989	-0.0166	0.6204	-0.1387	0.6046	0.0244
53	0.163	0.951	14.06	-15.0	-1.3910	-2.0233	-0.1495	-0.0069	0.4761	-0.1701	0.7028	-0.0009
54	0.154	1.000	14.07	-15.0	-1.4617	-2.0847	-0.1973	-0.0072	0.5397	-0.1730	0.7413	0.0056
55	0.157	1.052	14.08	-15.0	-1.4427	-1.8399	-0.3665	-0.0077	0.6990	-0.1508	0.6407	0.0021
56	0.178	1.101	14.08	-15.0	-1.4707	-1.9979	-0.3932	-0.0141	0.7254	-0.1877	0.7789	0.0120
57	0.180	1.150	14.09	-15.0	-1.4645	-1.8962	-0.3708	-0.0186	0.6982	-0.1636	0.6827	0.0117
58	0.183	1.202	14.11	-15.0	-1.4430	-1.6055	-0.4046	-0.0173	0.7273	-0.1730	0.7724	0.0103
59	0.163	0.948	16.08	-15.1	-1.6198	-2.2541	-0.1445	-0.0090	0.5788	-0.1605	0.6649	-0.0275
60	0.154	1.001	16.08	-15.1	-1.7367	-2.4037	-0.1893	-0.0074	0.6560	-0.1896	0.8070	-0.0065
61	0.157	1.051	16.10	-15.1	-1.7217	-2.1169	-0.3657	-0.0058	0.8235	-0.1708	0.7407	-0.0092
62	0.162	1.097	16.10	-15.0	-1.7320	-2.2349	-0.3750	-0.0198	0.8216	-0.2134	0.9287	0.0026
63	0.167	1.150	16.12	-15.0	-1.7420	-2.1050	-0.3733	-0.0236	0.8195	-0.1710	0.7736	-0.0005
64	0.168	1.200	16.14	-15.1	-1.7256	-1.7902	-0.4111	-0.0197	0.8558	-0.2146	0.8763	-0.0010
67	0.150	0.948	18.08	-15.1	-1.8966	-2.6004	-0.1338	-0.0077	0.7087	-0.1190	0.5952	-0.0374
68	0.154	1.000	18.10	-15.1	-2.0352	-2.7219	-0.1885	-0.0119	0.8003	-0.1656	0.7734	-0.0138
69	0.157	1.050	18.13	-15.1	-2.0380	-2.4274	-0.3525	-0.0062	0.9632	-0.1559	0.7615	-0.0168
70	0.160	1.101	18.14	-15.1	-2.0380	-2.4310	-0.3818	-0.0194	0.9787	-0.1891	0.8394	-0.0018
71	0.163	1.150	18.15	-15.1	-2.0697	-2.3109	-0.3715	-0.0225	0.9765	-0.1783	0.7923	-0.0100
72	0.167	1.202	18.18	-15.1	-2.0926	-1.9799	-0.4004	-0.0200	1.0145	-0.1991	0.8733	-0.0122
73	0.150	0.950	20.11	-15.1	-2.2378	-2.9119	-0.1216	-0.0101	0.8743	-0.0984	0.5147	-0.0406
74	0.154	1.000	20.14	-15.1	-2.4142	-2.9468	-0.1649	-0.0122	0.9747	-0.1437	0.7265	-0.0244
75	0.157	1.052	20.17	-15.1	-2.4341	-2.6672	-0.3559	-0.0074	1.1665	-0.1475	0.7072	-0.0231
76	0.160	1.102	20.18	-15.1	-2.4250	-2.6521	-0.3711	-0.0220	1.1643	-0.1823	0.8569	-0.0079
77	0.163	1.151	20.21	-15.1	-2.4936	-2.5373	-0.3589	-0.0223	1.1771	-0.1532	0.7518	-0.0173
78	0.167	1.199	20.24	-15.1	-2.5417	-2.1901	-0.3921	-0.0201	1.2285	-0.1572	0.8014	-0.0257
79	0.150	0.951	22.15	-15.1	-2.6728	-3.2201	-0.1124	-0.0177	1.0956	-0.0913	0.4678	-0.0468
80	0.154	1.002	22.19	-15.1	-2.8762	-3.1314	-0.1467	-0.0147	1.2088	-0.1622	0.7660	-0.0363
81	0.160	1.052	22.23	-15.1	-2.9127	-2.8501	-0.3464	-0.0127	1.4108	-0.1521	0.7995	-0.0366
82	0.163	1.101	22.24	-15.1	-2.9109	-2.8533	-0.3520	-0.0197	1.4093	-0.1381	0.7857	-0.0160
83	0.167	1.150	22.27	-15.1	-2.9786	-2.7088	-0.3492	-0.0241	1.4296	-0.1418	0.7123	-0.0262
84	0.168	1.198	22.31	-15.1	-3.0306	-2.2990	-0.3793	-0.0208	1.4824	-0.1676	0.8132	-0.0295
85	0.150	0.951	24.21	-15.1	-3.2160	-3.4348	-0.0858	-0.0144	1.3841	-0.0423	0.4257	-0.0629
86	0.157	0.999	24.27	-15.1	-3.4214	-3.1544	-0.1306	-0.0150	1.5117	-0.1892	0.9194	-0.0527
87	0.160	1.051	24.30	-15.1	-3.4633	-3.0100	-0.3274	-0.0073	1.7157	-0.1878	0.8947	-0.0571
88	0.163	1.100	24.31	-15.1	-3.4575	-3.0635	-0.3417	-0.0234	1.7134	-0.1367	0.7886	-0.0288

TABLE 1.05

DATA LISTINGS

ROLL ANGLE = -15 DEG.

SER	REYN	MACH	THETA	RANG	NORMAL	PITCH	AXIAL	BASE	DRAG	SIDE F	YAW M	ROLL M
90	0.167	1.148	24.34	-15.1	-3.5224	-2.9099	-0.3364	-0.0271	1.7336	-0.0827	0.6313	-0.0360
91	0.168	1.199	24.40	-15.1	-3.5761	-2.4786	-0.3703	-0.0220	1.7943	-0.0963	0.6782	-0.0423
92	0.152	0.952	26.28	-15.1	-3.7193	-3.3463	-0.0626	-0.0215	1.6840	-0.1731	0.7874	-0.0763
93	0.157	1.002	26.35	-15.1	-3.9041	-3.0035	-0.1124	-0.0161	1.8191	-0.2571	1.1432	-0.0641
94	0.160	1.048	26.38	-15.1	-3.9487	-2.8535	-0.2859	-0.0131	1.9990	-0.2256	1.0508	-0.0773
95	0.163	1.098	26.39	-15.1	-4.0204	-3.2232	-0.3326	-0.0245	2.0628	-0.1957	0.9878	-0.0497
96	0.167	1.148	26.42	-15.1	-4.0706	-3.0227	-0.3152	-0.0277	2.0689	-0.1270	0.8113	-0.0522
97	0.168	1.198	26.47	-15.1	-4.1252	-2.6654	-0.3410	-0.0224	2.1243	-0.1291	0.7763	-0.0555
98	0.152	0.948	28.35	-15.1	-4.2400	-3.4215	-0.0333	-0.0125	2.0317	-0.0535	0.5435	-0.0764
99	0.157	1.003	28.43	-15.1	-4.4396	-2.9618	-0.0919	-0.0130	2.1029	-0.1106	0.8588	-0.0703
100	0.162	1.052	28.45	-15.1	-4.5662	-3.2900	-0.2939	-0.0161	2.4194	-0.0945	0.7513	-0.0761
101	0.163	1.100	28.46	-15.1	-4.5790	-3.3726	-0.3006	-0.0260	2.4239	-0.0919	0.7908	-0.0615
102	0.168	1.152	28.51	-15.1	-4.6140	-3.1312	-0.2905	-0.0269	2.4338	-0.1680	0.8800	-0.0618
103	0.172	1.199	28.55	-15.1	-4.6776	-2.8358	-0.3214	-0.0241	2.4972	-0.1560	0.8173	-0.0650

TABLE 1.06

DATA LISTINGS

ROLL ANGLE = -7.5 DEG.

SER	REYN	MACH	THETA	RANG	NORMAL	PITCH	AXIAL	BASE	DRAG	SIDE F	YAW M	ROLL M
126	0.145	0.949	-2.02	-7.5	0.1096	0.0715	-0.1599	0.0073	0.1709	-0.0048	-0.0063	0.0180
127	0.149	0.998	-2.02	-7.5	0.1182	0.1061	-0.1779	0.0065	0.1884	0.0013	0.0188	0.0176
128	0.152	1.050	-2.02	-7.5	0.1076	0.0247	-0.3048	0.0088	0.3171	-0.0036	0.0350	0.0182
129	0.158	1.121	-2.02	-7.5	0.1150	0.0584	-0.3487	-0.0085	0.3440	0.0114	-0.0045	0.0183
130	0.158	1.150	-2.02	-7.5	0.1248	0.0846	-0.3480	-0.0108	0.3412	0.0236	-0.0766	0.0182
131	0.163	1.199	-2.02	-7.5	0.1486	0.1711	-0.3693	-0.0087	0.3655	-0.0035	0.0649	0.0180
132	0.147	0.949	-0.01	-7.5	-0.0239	-0.0601	-0.1549	0.0072	0.1621	0.0063	-0.0050	0.0170
133	0.152	0.998	-0.01	-7.5	-0.0278	-0.0759	-0.1809	0.0061	0.1870	0.0054	0.0128	0.0178
134	0.155	1.048	-0.01	-7.5	-0.0296	-0.0848	-0.3129	0.0139	0.3267	-0.0050	0.0685	0.0163
135	0.158	1.103	-0.01	-7.5	-0.0324	-0.1054	-0.3577	-0.0059	0.3518	0.0085	-0.0006	0.0180
136	0.162	1.150	-0.01	-7.5	-0.0298	-0.0868	-0.3493	-0.0104	0.3389	0.0289	-0.0708	0.0184
137	0.167	1.201	0.01	-7.5	-0.0104	-0.0074	-0.3744	-0.0086	0.3658	-0.0151	0.0814	0.0161
138	0.147	0.952	2.01	-7.5	-0.1626	-0.2185	-0.1516	0.0064	0.1635	0.0015	0.0050	0.0186
139	0.152	0.999	2.00	-7.5	-0.1802	-0.2768	-0.2012	0.0057	0.2131	-0.0071	0.0159	0.0184
140	0.173	1.049	2.01	-7.5	-0.1806	-0.2352	-0.3192	0.0131	0.3383	0.0018	0.0480	0.0182
141	0.162	1.098	2.01	-7.5	-0.1936	-0.3079	-0.3613	-0.0062	0.3616	0.0037	0.0143	0.0189
142	0.163	1.151	2.01	-7.5	-0.1847	-0.2767	-0.3454	-0.0100	0.3416	0.0063	-0.0512	0.0191
143	0.167	1.201	2.01	-7.5	-0.1687	-0.1897	-0.3737	-0.0082	0.3711	-0.0203	0.0976	0.0187
144	0.163	0.949	4.02	-7.5	-0.3210	-0.4323	-0.1571	0.0035	0.1826	-0.0002	0.0200	0.0213
145	0.152	0.998	4.02	-7.5	-0.3531	-0.5287	-0.1949	0.0030	0.2221	-0.0006	0.0308	0.0213
146	0.157	1.052	4.02	-7.5	-0.3524	-0.4656	-0.3294	0.0126	0.3658	-0.0075	0.0385	0.0218
147	0.160	1.100	4.02	-7.5	-0.3686	-0.5564	-0.3557	-0.0061	0.3745	0.0014	0.0329	0.0218
148	0.163	1.148	4.02	-7.5	-0.3610	-0.5135	-0.3559	-0.0120	0.3684	0.0061	-0.0373	0.0230
149	0.168	1.202	4.02	-7.5	-0.3458	-0.4177	-0.3798	-0.0112	0.3919	-0.0117	0.0584	0.0210
150	0.165	0.950	6.01	-7.5	-0.2159	-0.7615	-0.1616	0.0014	0.2161	-0.0118	0.0535	0.0248
151	0.157	1.001	6.01	-7.5	-0.2542	-0.8692	-0.1996	0.0009	0.2576	-0.0055	0.0618	0.0251
152	0.160	1.049	6.02	-7.5	-0.2347	-0.7035	-0.3200	0.0075	0.3818	-0.0064	0.0841	0.0249
153	0.160	1.099	6.02	-7.5	-0.2675	-0.8756	-0.3717	-0.0111	0.4181	-0.0114	0.0637	0.0251
154	0.167	1.149	6.02	-7.5	-0.2556	-0.8170	-0.3479	-0.0147	0.3897	0.0007	-0.0020	0.0265
155	0.168	1.199	6.03	-7.5	-0.2313	-0.6618	-0.3891	-0.0150	0.4278	-0.0353	0.1434	0.0238
156	0.152	0.950	8.02	-7.5	-0.7267	-1.1263	-0.1586	0.0006	0.2592	-0.0161	0.1210	0.0262
157	0.157	1.002	8.02	-7.5	-0.7736	-1.2438	-0.2067	-0.0020	0.3106	-0.0259	0.1497	0.0259
158	0.160	1.048	8.03	-7.5	-0.7613	-1.0834	-0.3305	0.0084	0.4420	-0.0213	0.1090	0.0266
159	0.163	1.099	8.03	-7.5	-0.7837	-1.2136	-0.3790	-0.0131	0.4718	-0.0197	0.1309	0.0270
160	0.183	1.152	8.04	-7.5	-0.7684	-1.1458	-0.3665	-0.0177	0.4528	-0.0317	0.0247	0.0282
161	0.168	1.198	8.05	-7.5	-0.7416	-0.9479	-0.3983	-0.0169	0.4815	-0.0437	0.2041	0.0262
164	0.145	0.948	10.03	-7.5	-0.9394	-1.4774	-0.1538	0.0014	0.3165	-0.0335	0.1772	0.0218
165	0.149	0.998	10.03	-7.5	-1.0007	-1.6157	-0.2113	-0.0035	0.3789	-0.0473	0.2131	0.0259
166	0.152	1.049	10.04	-7.5	-0.9925	-1.4318	-0.3371	0.0056	0.5105	-0.0322	0.1575	0.0244
167	0.155	1.102	10.04	-7.5	-1.0057	-1.5288	-0.3900	-0.0157	0.5438	-0.0469	0.2290	0.0271
168	0.158	1.150	10.05	-7.5	-0.9971	-1.4648	-0.3778	-0.0214	0.5248	-0.0184	0.1072	0.0286

TABLE 1.06

DATA LISTINGS

ROLL ANGLE = -7,5 DEG.

SER	REYN	MACH	THETA	RANG	NORMAL	PITCH	AXIAL	BASE	DRAG	SIDE F	YAW M	ROLL M
169	0.162	1.201	10.06	-7,5	-0.9702	-1.2460	-0.4136	-0.0204	0.5566	-0.2448	0.2320	0.0271
170	0.157	0.950	12.04	-7,5	-1.1867	-1.8641	-0.1562	-0.0048	0.3956	-0.0594	0.2769	0.0160
171	0.149	1.002	12.05	-7,5	-1.2490	-1.9684	-0.2120	-0.0059	0.4622	-0.0683	0.3131	0.0234
172	0.152	1.050	12.06	-7,5	-1.2307	-1.7256	-0.3538	0.0026	0.6056	-0.0494	0.2370	0.0185
173	0.158	1.100	12.06	-7,5	-1.2489	-1.8518	-0.3897	-0.0178	0.6246	-0.0695	0.3373	0.0238
174	0.158	1.148	12.07	-7,5	-1.2424	-1.7721	-0.3864	-0.0236	0.6145	-0.0491	0.2104	0.0266
175	0.162	1.199	12.08	-7,5	-1.2110	-1.5116	-0.4048	-0.0213	0.6284	-0.0719	0.3460	0.0263
176	0.160	0.950	14.05	-7,5	-1.4434	-2.2339	-0.1489	-0.0040	0.4910	-0.0755	0.3614	0.0050
177	0.152	1.000	14.05	-7,5	-1.5144	-2.3209	-0.2128	-0.0079	0.5667	-0.0823	0.3607	0.0123
178	0.170	1.049	14.07	-7,5	-1.4931	-2.0397	-0.3597	-0.0007	0.7114	-0.0672	0.3290	0.0108
179	0.158	1.102	14.08	-7,5	-1.5100	-2.1623	-0.3933	-0.0218	0.7275	-0.0952	0.4440	0.0185
180	0.162	1.152	14.08	-7,5	-1.5018	-2.0534	-0.3803	-0.0247	0.7103	-0.0593	0.3016	0.0202
181	0.163	1.200	14.11	-7,5	-1.4752	-1.7650	-0.4084	-0.0216	0.7346	-0.1050	0.4713	0.0194
182	0.147	0.950	16.06	-7,6	-1.7089	-2.5951	-0.1382	-0.0050	0.6009	-0.0769	0.3956	-0.0036
183	0.152	1.000	16.07	-7,5	-1.0007	-2.7127	-0.1986	-0.0095	0.6800	-0.0754	0.3846	0.0026
184	0.155	1.049	16.09	-7,5	-1.7698	-2.3279	-0.3502	0.0006	0.8278	-0.0924	0.4485	0.0005
185	0.162	1.098	16.09	-7,5	-1.7873	-2.4591	-0.3790	-0.0216	0.8389	-0.0968	0.4801	0.0111
186	0.163	1.151	16.11	-7,5	-1.7858	-2.3039	-0.3792	-0.0260	0.8350	-0.0879	0.4333	0.0076
188	0.167	1.201	16.13	-7,5	-1.7849	-2.0205	-0.4110	-0.0236	0.8682	-0.1060	0.5001	0.0070
189	0.147	0.950	18.08	-7,6	-1.9936	-2.9534	-0.1323	-0.0071	0.7379	-0.0651	0.3478	-0.0083
190	0.154	0.999	18.09	-7,6	-2.1167	-3.0603	-0.1809	-0.0110	0.8191	-0.0741	0.4074	-0.0048
191	0.172	1.049	18.12	-7,6	-2.1202	-2.7529	-0.3743	-0.0023	1.0131	-0.0739	0.4344	-0.0032
192	0.162	1.098	18.12	-7,5	-2.1029	-2.7255	-0.3859	-0.0217	1.0004	-0.0620	0.4113	0.0052
193	0.163	1.150	18.14	-7,5	-2.1324	-2.5730	-0.3789	-0.0274	0.9982	-0.0679	0.3970	0.0001
194	0.168	1.200	18.18	-7,5	-2.1556	-2.2434	-0.4160	-0.0226	1.0464	-0.0874	0.4741	-0.0003
197	0.142	0.950	20.10	-7,6	-2.5252	-3.1853	-0.1303	-0.0006	0.9135	-0.0259	0.2214	-0.0118
198	0.149	1.001	20.13	-7,6	-2.5130	-3.2759	-0.1651	-0.0119	1.0087	-0.0693	0.3844	-0.0068
199	0.152	1.050	20.15	-7,6	-2.5289	-2.9514	-0.3396	-0.0050	1.1856	-0.0631	0.3984	-0.0033
200	0.154	1.098	20.16	-7,5	-2.5124	-2.9395	-0.3722	-0.0210	1.1957	-0.0971	0.4628	0.0091
201	0.157	1.149	20.18	-7,5	-2.5681	-2.8061	-0.3704	-0.0266	1.2089	-0.0536	0.3725	-0.0001
202	0.176	1.199	20.22	-7,6	-2.6070	-2.4425	-0.3956	-0.0215	1.2524	-0.0902	0.4652	-0.0026
203	0.145	0.949	22.14	-7,6	-2.7964	-3.4702	-0.0986	-0.0104	1.1360	-0.0351	0.2499	-0.0167
204	0.162	1.001	22.18	-7,6	-3.0235	-3.4852	-0.1513	-0.0118	1.2709	-0.0832	0.4693	-0.0131
205	0.152	1.050	22.21	-7,6	-3.0288	-3.1672	-0.3281	-0.0125	1.4374	-0.0799	0.4606	-0.0097
206	0.157	1.098	22.22	-7,5	-3.0107	-3.1951	-0.3650	-0.0248	1.4535	-0.0759	0.4276	0.0043
207	0.158	1.152	22.25	-7,5	-3.0596	-2.9432	-0.3659	-0.0241	1.4752	-0.0893	0.4321	-0.0010
208	0.162	1.198	22.29	-7,6	-3.1049	-2.5772	-0.3825	-0.0201	1.5134	-0.1090	0.5142	-0.0044
209	0.144	0.951	24.20	-7,6	-3.3683	-3.8371	-0.0770	-0.0073	1.4444	-0.0323	0.2922	-0.0299
210	0.149	0.999	24.24	-7,6	-3.5579	-3.5845	-0.1305	-0.0124	1.5691	-0.0980	0.5731	-0.0225
211	0.155	1.049	24.27	-7,6	-3.5918	-3.4237	-0.3258	-0.0059	1.7686	-0.0829	0.5075	-0.0174
212	0.158	1.101	24.28	-7,6	-3.5539	-3.3986	-0.3488	-0.0229	1.7589	-0.0454	0.4182	-0.0015

TABLE 1.06

DATA LISTINGS

ROLL ANGLE = -7.5 DEG.

SER	REYN	MACH	THETA	RANG	NORMAL	PITCH	AXIAL	BASE	DRAG	SIDE F	YAW M	ROLL M
213	0.162	1.150	24.32	-7.0	-3.0000	-3.1457	-0.3427	-0.0256	1.7720	-0.0726	0.4208	-0.0073
214	0.162	1.198	24.37	-7.0	-3.0438	-2.7818	-0.3680	-0.0199	1.8206	-0.0623	0.4355	-0.0126
215	0.147	0.952	26.26	-7.0	-3.9124	-4.0962	-0.0400	-0.0094	1.7583	0.0138	0.3342	-0.0300
216	0.152	0.998	26.32	-7.0	-4.0712	-3.6240	-0.1112	-0.0133	1.8929	0.0227	0.3342	-0.0198
217	0.170	1.049	26.35	-7.0	-4.1258	-3.5424	-0.2958	-0.0149	2.0831	0.0075	0.3438	-0.0186
218	0.158	1.101	26.36	-7.0	-4.1203	-3.6272	-0.3375	-0.0249	2.1098	-0.0113	0.3895	-0.0111
219	0.178	1.150	26.40	-7.0	-4.1683	-3.3304	-0.3185	-0.0265	2.1152	-0.0367	0.4240	-0.0130
220	0.163	1.202	26.45	-7.0	-4.1956	-2.9154	-0.3433	-0.0224	2.1564	-0.0835	0.5269	-0.0220
221	0.147	0.950	28.32	-7.0	-4.4310	-4.1820	-0.0253	-0.0093	2.1162	0.0520	0.2661	-0.0231
222	0.152	1.001	28.40	-7.0	-4.2826	-3.5480	-0.0879	-0.0141	2.2444	0.0039	0.3966	-0.0206
223	0.155	1.049	28.42	-7.0	-4.0659	-3.6387	-0.2784	-0.0144	2.4533	-0.0261	0.4658	-0.0195
224	0.162	1.098	28.44	-7.0	-4.0775	-3.7195	-0.3160	-0.0259	2.4830	-0.0694	0.6276	-0.0214
225	0.163	1.150	28.48	-7.0	-4.7070	-3.4645	-0.2960	-0.0271	2.4811	-0.0778	0.5440	-0.0234
226	0.183	1.200	28.53	-7.0	-4.7419	-3.1375	-0.3221	-0.0214	2.5290	-0.0770	0.5402	-0.0256

TABLE 1.07

DATA LISTINGS

ROLL ANGLE = 0 DEG.

SER	REYN	MACH	THETA	RANG	NORMAL	PITCH	AXIAL	BASE	DRAG	SIDE F	YAW M	ROLL M
2	0.150	0.948	-2.01	0.0	0.1125	0.0808	-0.1557	0.0080	0.1675	0.0025	0.0169	0.0166
3	0.157	1.000	-2.01	0.0	0.1231	0.1146	-0.1961	0.0068	0.2071	0.0094	-0.0033	0.0169
4	0.157	1.050	-2.02	0.0	0.1133	0.0379	-0.3124	0.0113	0.3275	0.0076	0.0244	0.0171
5	0.160	1.099	-2.02	0.0	0.1180	0.0684	-0.3574	-0.0038	0.3575	0.0140	-0.0200	0.0169
6	0.183	1.153	-2.02	0.0	0.1277	0.0927	-0.3396	-0.0075	0.3364	0.0238	-0.0001	0.0166
7	0.168	1.199	-2.02	0.0	0.1485	0.1657	-0.3720	-0.0081	0.3688	-0.0090	0.0682	0.0175
8	0.150	0.950	-0.01	0.0	-0.0215	-0.0624	-0.1723	0.0071	0.1793	-0.0139	0.0216	0.0166
9	0.154	1.001	-0.01	0.0	-0.0229	-0.0725	-0.2108	0.0071	0.2178	0.0048	0.0261	0.0159
10	0.157	1.049	-0.01	0.0	-0.0295	-0.1035	-0.3173	0.0112	0.3284	0.0087	0.0088	0.0170
11	0.163	1.101	-0.01	0.0	-0.0307	-0.1122	-0.3550	-0.0062	0.3487	0.0170	-0.0367	0.0161
12	0.167	1.151	-0.01	0.0	-0.0247	-0.0822	-0.3514	-0.0071	0.3443	0.0072	-0.0331	0.0167
13	0.168	1.199	0.01	0.0	-0.0110	-0.0154	-0.3638	-0.0063	0.3574	-0.0102	0.0401	0.0164
14	0.150	0.949	2.00	0.0	-0.1609	-0.2186	-0.1646	0.0035	0.1736	0.0080	-0.0052	0.0172
15	0.157	1.002	2.00	0.0	-0.1798	-0.2739	-0.1938	0.0050	0.2049	0.0043	-0.0157	0.0166
16	0.160	1.049	2.00	0.0	-0.1769	-0.2423	-0.3224	0.0102	0.3385	-0.0003	0.0032	0.0162
17	0.163	1.102	2.00	0.0	-0.1843	-0.2874	-0.3630	-0.0049	0.3643	0.0040	-0.0053	0.0178
18	0.167	1.150	2.00	0.0	-0.1814	-0.2754	-0.3465	-0.0076	0.3449	0.0150	-0.0781	0.0177
19	0.168	1.200	2.01	0.0	-0.1667	-0.1897	-0.3681	-0.0068	0.3668	-0.0157	0.0961	0.0167
20	0.150	0.949	4.01	0.0	-0.3209	-0.4341	-0.1692	0.0053	0.1965	0.0030	-0.0121	0.0200
21	0.157	1.000	4.01	0.0	-0.3528	-0.5290	-0.2054	0.0033	0.2329	0.0112	-0.0087	0.0205
22	0.160	1.052	4.01	0.0	-0.3495	-0.4730	-0.3330	0.0069	0.3635	-0.0004	0.0115	0.0204
23	0.163	1.101	4.01	0.0	-0.3560	-0.5166	-0.3687	-0.0037	0.3890	0.0076	0.0007	0.0210
24	0.167	1.150	4.01	0.0	-0.3543	-0.5113	-0.3510	-0.0105	0.3645	0.0187	-0.0790	0.0207
25	0.172	1.200	4.02	0.0	-0.3409	-0.4086	-0.3823	-0.0096	0.3957	-0.0083	0.0592	0.0195
26	0.152	0.950	6.02	0.0	-0.5102	-0.7636	-0.1623	0.0042	0.2190	0.0117	-0.0082	0.0235
27	0.157	1.000	6.02	0.0	-0.5537	-0.8717	-0.2092	-0.0004	0.2657	0.0099	-0.0385	0.0236
28	0.175	1.050	6.02	0.0	-0.5526	-0.8009	-0.3503	0.0025	0.4088	0.0032	-0.0086	0.0240
29	0.165	1.102	6.02	0.0	-0.5588	-0.8504	-0.3673	-0.0081	0.4158	0.0102	-0.0427	0.0235
30	0.167	1.148	6.02	0.0	-0.5525	-0.8115	-0.3649	-0.0133	0.4076	0.0150	-0.0577	0.0247
31	0.168	1.198	6.03	0.0	-0.5312	-0.6730	-0.3954	-0.0142	0.4348	-0.0098	0.0571	0.0232
32	0.152	0.952	8.02	0.0	-0.7281	-1.1540	-0.1625	0.0010	0.2635	0.0116	-0.0458	0.0258
33	0.157	1.000	8.02	0.0	-0.7739	-1.2645	-0.2081	-0.0007	0.3134	0.0012	-0.0017	0.0263
34	0.160	1.049	8.03	0.0	-0.7681	-1.1327	-0.3383	0.0031	0.4454	0.0031	-0.0062	0.0255
35	0.165	1.099	8.03	0.0	-0.7789	-1.2068	-0.3837	-0.0093	0.4795	0.0079	-0.0220	0.0260
36	0.168	1.149	8.03	0.0	-0.7697	-1.1569	-0.3636	-0.0187	0.4491	0.0238	-0.1014	0.0264
37	0.172	1.200	8.04	0.0	-0.7444	-0.9717	-0.4021	-0.0180	0.4845	-0.0189	0.0723	0.0249
2	0.147	0.951	10.03	0.0	-0.9531	-1.5387	-0.1556	-0.0004	0.3188	0.0265	-0.0712	0.0235
3	0.152	1.000	10.03	0.0	-1.0065	-1.6381	-0.2030	-0.0045	0.3708	0.0187	-0.0327	0.0258
4	0.155	1.051	10.04	0.0	-1.0095	-1.5370	-0.3569	0.0048	0.5322	0.0005	0.0142	0.0252
5	0.158	1.100	10.02	0.0	-1.0095	-1.5613	-0.3849	-0.0153	0.5395	0.0148	-0.0384	0.0258
6	0.163	1.151	10.04	0.0	-0.9988	-1.4987	-0.3770	-0.0204	0.5254	0.0329	-0.1169	0.0256

TABLE 1.07
 DATA LISTINGS
 ROLL ANGLE = 0 DEG.

SER	REYN	MACH	THETA	RANG	NORMAL	PITCH	AXIAL	BASE	DRAG	SIDE F	YAW M	ROLL M
7	0.163	1.201	10.06	0.0	-0.9749	-1.2768	-0.4139	-0.0208	0.5573	-0.0076	0.0499	0.0251
8	0.147	0.950	12.04	0.0	-1.2029	-1.9367	-0.1711	-0.0033	0.4149	0.0058	-0.0357	0.0215
9	0.152	0.998	12.04	0.0	-1.2634	-2.0618	-0.2081	-0.0065	0.4607	0.0301	-0.0334	0.0233
10	0.157	1.050	12.05	0.0	-1.2538	-1.8586	-0.3581	-0.0026	0.6094	0.0085	-0.0135	0.0220
11	0.175	1.098	12.05	0.0	-1.2551	-1.9119	-0.3931	-0.0180	0.6290	0.0093	0.0010	0.0227
12	0.163	1.148	12.06	0.0	-1.2468	-1.8206	-0.3810	-0.0214	0.6121	0.0251	-0.0708	0.0247
13	0.167	1.200	12.08	0.0	-1.2167	-1.5553	-0.4055	-0.0218	0.6299	-0.0001	0.0331	0.0231
14	0.163	0.952	14.05	0.0	-1.4652	-2.3328	-0.1580	-0.0026	0.5065	0.0260	-0.0497	0.0200
15	0.154	1.000	14.05	0.0	-1.7427	-2.4613	-0.2042	-0.0085	0.5645	0.0115	0.0101	0.0191
16	0.155	1.051	14.07	0.0	-1.7308	-2.2337	-0.3628	-0.0052	0.7190	0.0328	-0.0672	0.0186
17	0.160	1.102	14.07	0.0	-1.7210	-2.2275	-0.3934	-0.0208	0.7312	0.0156	-0.0268	0.0234
18	0.163	1.152	14.08	0.0	-1.7112	-2.1184	-0.3864	-0.0221	0.7211	0.0361	-0.1018	0.0247
19	0.167	1.199	14.10	0.0	-1.4908	-1.8388	-0.4168	-0.0236	0.7446	-0.0121	0.0251	0.0259
20	0.147	0.950	16.06	0.0	-1.7388	-2.7323	-0.1507	-0.0047	0.6215	0.0243	-0.0565	0.0150
21	0.154	1.001	16.07	0.0	-1.8336	-2.8262	-0.1981	-0.0074	0.6909	0.0394	-0.0816	0.0152
22	0.157	1.049	16.09	0.0	-1.8105	-2.5204	-0.3533	-0.0007	0.8407	0.0341	-0.0908	0.0175
23	0.160	1.102	16.09	0.0	-1.7959	-2.5138	-0.3919	-0.0219	0.8534	0.0391	-0.0914	0.0221
24	0.167	1.151	16.11	0.0	-1.8016	-2.3786	-0.3807	-0.0263	0.8405	0.0316	-0.1349	0.0200
25	0.167	1.199	16.13	0.0	-1.7959	-2.0965	-0.4103	-0.0237	0.8705	0.0205	-0.0242	0.0215
26	0.150	0.951	18.08	0.0	-2.0155	-3.0810	-0.1334	-0.0060	0.7466	0.0775	-0.2036	0.0176
27	0.168	1.002	18.09	0.0	-2.1425	-3.1685	-0.1716	-0.0100	0.8191	0.0617	-0.1857	0.0190
28	0.158	1.048	18.12	0.0	-2.1260	-2.7964	-0.3482	-0.0038	0.9886	0.0772	-0.1963	0.0200
29	0.160	1.101	18.13	0.0	-2.1187	-2.7807	-0.3895	-0.0241	1.0065	0.0512	-0.1300	0.0245
30	0.180	1.149	18.14	0.0	-2.1503	-2.6777	-0.3841	-0.0281	1.0080	0.0704	-0.2230	0.0190
31	0.168	1.199	18.18	0.0	-2.1729	-2.3486	-0.4132	-0.0234	1.0482	0.0399	-0.1024	0.0227
34	0.157	0.952	20.10	0.0	-2.3617	-3.3707	-0.1149	-0.0045	0.9153	0.0567	-0.1764	0.0229
35	0.149	1.001	20.12	0.0	-2.5640	-3.4314	-0.1660	-0.0098	1.0289	0.0708	-0.2107	0.0220
36	0.152	1.050	20.15	0.0	-2.5741	-3.1627	-0.3564	-0.0123	1.2099	0.0675	-0.1783	0.0244
37	0.170	1.100	20.16	0.0	-2.5388	-3.0296	-0.3765	-0.0234	1.2065	0.0531	-0.1409	0.0328
38	0.158	1.150	20.18	0.0	-2.5930	-2.8916	-0.3670	-0.0243	1.2164	0.0691	-0.2434	0.0288
39	0.160	1.198	20.22	0.0	-2.6297	-2.5629	-0.4012	-0.0214	1.2653	0.0700	-0.1995	0.0326
40	0.145	0.950	22.14	0.0	-2.8880	-3.7229	-0.1030	-0.0070	1.1776	0.0527	-0.1714	0.0239
41	0.149	0.998	22.18	0.0	-3.0943	-3.6889	-0.1438	-0.0122	1.2902	0.0921	-0.2477	0.0252
42	0.152	1.050	22.20	0.0	-3.0967	-3.4542	-0.3562	-0.0119	1.4893	0.0895	-0.2391	0.0294
43	0.170	1.099	22.22	0.0	-3.0431	-3.3112	-0.3635	-0.0226	1.4663	0.0673	-0.2096	0.0375
44	0.158	1.151	22.25	0.0	-3.0893	-3.0897	-0.3542	-0.0223	1.4770	0.1392	-0.4000	0.0321
45	0.162	1.201	22.29	0.0	-3.1425	-2.7046	-0.3869	-0.0183	1.5331	0.0752	-0.1775	0.0384
46	0.144	0.951	24.19	0.0	-3.4543	-4.1003	-0.0763	-0.0070	1.4791	0.0551	-0.1451	0.0252
47	0.149	1.000	24.24	0.0	-3.6048	-3.7669	-0.1233	-0.0114	1.5825	0.0625	-0.1693	0.0256
48	0.152	1.050	24.27	0.0	-3.6224	-3.5886	-0.3272	-0.0131	1.7755	0.0504	-0.1236	0.0293
49	0.155	1.100	24.28	0.0	-3.6104	-3.5559	-0.3481	-0.0209	1.7832	0.0777	-0.2240	0.0377

TABLE 1.07

DATA LISTINGS

ROLL ANGLE = 0 DEG.

SER	REYN	MACH	THETA	RANG	NORMAL	PITCH	AXIAL	BASE	DRAG	SIDE F	YAW M	ROLL M
50	0.158	1.149	24.32	0.0	-3.6533	-3.3348	-0.3308	-0.0222	1.7857	0.1266	-0.3817	0.0386
51	0.162	1.198	24.36	0.0	-3.6928	-2.9276	-0.3667	-0.0197	1.8396	0.0827	-0.2314	0.0362
52	0.160	0.949	26.24	0.0	-3.9674	-4.3544	-0.0429	-0.0051	1.7885	0.1528	-0.3831	0.0265
53	0.152	1.002	26.31	0.0	-4.1086	-3.7454	-0.1166	-0.0133	1.9141	0.2140	-0.4980	0.0266
54	0.152	1.048	26.34	0.0	-4.1666	-3.7817	-0.3125	-0.0130	2.1170	0.1713	-0.3634	0.0308
55	0.158	1.098	26.35	0.0	-4.1632	-3.8048	-0.3370	-0.0248	2.1278	0.1447	-0.3420	0.0369
56	0.158	1.148	26.39	0.0	-4.2021	-3.5377	-0.3132	-0.0253	2.1258	0.1517	-0.4184	0.0370
57	0.162	1.201	26.44	0.0	-4.2384	-3.1284	-0.3470	-0.0201	2.1801	0.0935	-0.2088	0.0331
58	0.147	0.950	28.31	0.0	-4.4631	-4.3824	-0.0001	-0.0094	2.1086	0.2066	-0.4339	0.0316
59	0.163	1.001	28.39	0.0	-4.6209	-3.7095	-0.0923	-0.0115	2.2682	0.0970	-0.1966	0.0288
60	0.170	1.052	28.41	0.0	-4.7004	-3.8889	-0.2996	-0.0141	2.4876	0.0611	-0.1088	0.0310
61	0.158	1.100	28.43	0.0	-4.7032	-3.9123	-0.3094	-0.0233	2.4907	0.0944	-0.1975	0.0353
62	0.162	1.149	28.47	0.0	-4.7407	-3.6299	-0.2938	-0.0248	2.4966	0.0771	-0.1884	0.0324
63	0.180	1.198	28.51	0.0	-4.7768	-3.2996	-0.3255	-0.0205	2.5486	0.1288	-0.2624	0.0367

TABLE 1.08
 DATA LISTINGS
 ROLL ANGLE = 7.5 DEG.

SER	REYN	MACH	THETA	RANG	NORMAL	PITCH	AXIAL	BASE	DRAG	SIDE F	YAW M	ROLL M
67	0.142	0.949	-2.02	7.5	0.1115	0.0755	-0.1608	0.0070	0.1716	0.0084	0.0004	0.0168
68	0.147	0.998	-2.02	7.5	0.1215	0.1102	-0.1866	0.0059	0.1966	0.0116	-0.0110	0.0172
69	0.165	1.050	-2.02	7.5	0.1122	0.0401	-0.3147	0.0103	0.3286	0.0123	0.0097	0.0180
70	0.168	1.101	-2.02	7.5	0.1187	0.0649	-0.3543	-0.0058	0.3524	0.0133	-0.0086	0.0166
71	0.157	1.148	-2.02	7.5	0.1281	0.0883	-0.3486	-0.0107	0.3421	0.0254	-0.0683	0.0177
72	0.160	1.199	-2.02	7.5	0.1474	0.1596	-0.3651	-0.0086	0.3614	-0.0069	0.0488	0.0172
73	0.144	0.952	-0.01	7.5	-0.0215	-0.0629	-0.1525	0.0058	0.1583	0.0094	-0.0174	0.0160
74	0.149	0.999	-0.01	7.5	-0.0264	-0.0778	-0.1974	0.0052	0.2025	0.0041	0.0140	0.0170
75	0.152	1.051	-0.01	7.5	-0.0303	-0.0988	-0.3297	0.0118	0.3414	0.0087	0.0052	0.0163
76	0.154	1.099	-0.01	7.5	-0.0310	-0.1050	-0.3550	-0.0051	0.3499	0.0183	-0.0260	0.0166
77	0.173	1.149	-0.01	7.5	-0.0261	-0.0889	-0.3409	-0.0106	0.3303	0.0234	-0.0741	0.0152
78	0.162	1.199	0.01	7.5	-0.0104	-0.0081	-0.3732	-0.0088	0.3643	-0.0050	0.0629	0.0169
79	0.145	0.949	2.01	7.5	-0.1630	-0.2273	-0.1611	0.0051	0.1717	0.0081	-0.0008	0.0165
80	0.149	0.999	2.00	7.5	-0.1784	-0.2707	-0.1959	0.0048	0.2067	0.0071	-0.0151	0.0170
81	0.168	1.049	2.01	7.5	-0.1777	-0.2369	-0.3129	0.0124	0.3313	0.0043	0.0118	0.0170
82	0.157	1.100	2.01	7.5	-0.1864	-0.2970	-0.3572	-0.0063	0.3572	0.0138	-0.0292	0.0175
83	0.175	1.150	2.01	7.5	-0.1843	-0.2746	-0.3427	-0.0102	0.3387	0.0249	-0.0924	0.0183
84	0.162	1.200	2.01	7.5	-0.1672	-0.1856	-0.3717	-0.0084	0.3688	-0.0148	0.0696	0.0177
85	0.144	0.951	4.01	7.5	-0.3207	-0.4323	-0.1660	0.0043	0.1922	0.0155	-0.0595	0.0194
86	0.149	1.002	4.01	7.5	-0.3497	-0.5152	-0.1997	0.0037	0.2273	0.0120	-0.0521	0.0200
87	0.167	1.050	4.01	7.5	-0.3473	-0.4545	-0.3361	0.0097	0.3692	0.0130	-0.0197	0.0192
88	0.155	1.102	4.01	7.5	-0.3614	-0.5274	-0.3631	-0.0078	0.3797	0.0172	-0.0493	0.0203
89	0.176	1.148	4.01	7.5	-0.3570	-0.5065	-0.3555	-0.0116	0.3680	0.0301	-0.0017	0.0203
90	0.162	1.199	4.01	7.5	-0.3387	-0.4012	-0.3768	-0.0107	0.3889	0.0014	0.0385	0.0201
91	0.147	0.951	6.01	7.5	-0.5051	-0.7373	-0.1578	0.0039	0.2137	0.0356	-0.1032	0.0234
92	0.152	0.999	6.01	7.5	-0.5476	-0.8447	-0.2107	-0.0004	0.2665	0.0368	-0.1169	0.0239
93	0.167	1.049	6.02	7.5	-0.5375	-0.7311	-0.3378	0.0093	0.4016	0.0357	-0.0863	0.0220
94	0.158	1.100	6.02	7.5	-0.5588	-0.8483	-0.3729	-0.0105	0.4191	0.0298	-0.1108	0.0228
95	0.162	1.152	6.02	7.5	-0.5485	-0.8003	-0.3551	-0.0139	0.3969	0.0451	-0.1706	0.0228
96	0.163	1.201	6.03	7.5	-0.5312	-0.6621	-0.3988	-0.0148	0.4376	0.0062	-0.0010	0.0218
97	0.147	0.952	8.02	7.5	-0.7192	-1.1156	-0.1668	0.0014	0.2669	0.0593	-0.1920	0.0250
98	0.163	0.999	8.02	7.5	-0.7632	-1.2038	-0.2116	-0.0017	0.3144	0.0496	-0.1851	0.0244
99	0.155	1.049	8.03	7.5	-0.7666	-1.1242	-0.3602	0.0063	0.4701	0.0351	-0.1218	0.0238
100	0.158	1.100	8.03	7.5	-0.7753	-1.1917	-0.3726	-0.0138	0.4637	0.0465	-0.1843	0.0246
101	0.162	1.152	8.03	7.5	-0.7601	-1.1230	-0.3733	-0.0179	0.4582	0.0640	-0.2431	0.0246
102	0.163	1.200	8.05	7.5	-0.7397	-0.9377	-0.4013	-0.0175	0.4835	0.0147	-0.0734	0.0227
105	0.145	0.949	10.03	7.5	-0.9418	-1.4895	-0.1700	0.0000	0.3314	0.0826	-0.2713	0.0259
106	0.149	1.000	10.03	7.5	-0.9934	-1.5704	-0.2140	-0.0053	0.3786	0.0693	-0.2593	0.0263
107	0.165	1.050	10.04	7.5	-0.9935	-1.4626	-0.3500	0.0052	0.5230	0.0602	-0.2208	0.0217
108	0.154	1.099	10.04	7.5	-0.9990	-1.5266	-0.3779	-0.0164	0.5301	0.0745	-0.2478	0.0247
109	0.158	1.152	10.05	7.5	-0.9883	-1.4469	-0.3728	-0.0200	0.5197	0.0791	-0.3024	0.0226

TABLE 1.08
DATA LISTINGS

ROLL ANGLE = 7.5 DEG.

SER	REYN	MACH	THETA	RANG	NORMAL	PITCH	AXIAL	BASE	DRAG	SIDE F	YAW M	ROLL M
110	0.160	1.198	10.06	7.5	-0.9623	-1.2253	-0.4043	-0.0196	0.5469	0.0411	-0.1303	0.0232
111	0.145	0.948	12.03	7.5	-1.1886	-1.0742	-0.1587	-0.0022	0.4009	0.0994	-0.3539	0.0284
112	0.149	0.999	12.05	7.5	-1.2494	-1.9784	-0.1998	-0.0069	0.4492	0.1034	-0.3687	0.0257
113	0.152	1.049	12.06	7.5	-1.2283	-1.7405	-0.3390	-0.0027	0.5855	0.0877	-0.3075	0.0221
114	0.157	1.099	12.06	7.5	-1.2483	-1.8670	-0.3938	-0.0178	0.6284	0.0938	-0.3468	0.0220
115	0.158	1.150	12.06	7.5	-1.2369	-1.7694	-0.3710	-0.0219	0.5999	0.1064	-0.4272	0.0228
116	0.162	1.200	12.08	7.5	-1.2029	-1.5026	-0.4002	-0.0208	0.6227	0.0758	-0.2289	0.0236
117	0.144	0.952	14.04	7.5	-1.4500	-2.2782	-0.1484	-0.0076	0.4886	0.1234	-0.4634	0.0316
118	0.149	1.000	14.05	7.5	-1.5289	-2.4019	-0.1955	-0.0079	0.5533	0.1235	-0.4513	0.0229
119	0.152	1.050	14.07	7.5	-1.5003	-2.0955	-0.3522	-0.0004	0.7061	0.1171	-0.4079	0.0263
120	0.155	1.100	14.07	7.5	-1.5150	-2.1811	-0.3847	-0.0192	0.7229	0.1362	-0.5021	0.0313
121	0.158	1.149	14.08	7.5	-1.5013	-2.0764	-0.3734	-0.0244	0.7038	0.1593	-0.5599	0.0253
122	0.162	1.198	14.10	7.5	-1.4771	-1.7866	-0.4123	-0.0218	0.7386	0.1085	-0.3716	0.0280
123	0.147	0.952	16.06	7.5	-1.7089	-2.6390	-0.1434	-0.0054	0.6053	0.1768	-0.6172	0.0377
124	0.149	0.998	16.07	7.5	-1.8067	-2.7356	-0.1966	-0.0092	0.6803	0.1605	-0.5563	0.0281
125	0.155	1.049	16.09	7.5	-1.7851	-2.4070	-0.3611	-0.0007	0.8411	0.1564	-0.5625	0.0320
126	0.173	1.099	16.09	7.5	-1.7851	-2.4665	-0.3830	-0.0206	0.8431	0.1712	-0.6416	0.0346
127	0.162	1.149	16.10	7.5	-1.7911	-2.3402	-0.3762	-0.0257	0.8337	0.1906	-0.7024	0.0321
128	0.163	1.200	16.13	7.5	-1.7831	-2.0212	-0.4068	-0.0219	0.8652	0.1530	-0.5458	0.0356
129	0.147	0.948	18.08	7.5	-1.9699	-2.9126	-0.1350	-0.0090	0.7311	0.1894	-0.7010	0.0503
130	0.152	1.000	18.09	7.5	-2.1132	-3.0624	-0.1653	-0.0115	0.8026	0.1988	-0.6866	0.0321
131	0.170	1.049	18.12	7.5	-2.1065	-2.6841	-0.3523	-0.0020	0.9881	0.2157	-0.7463	0.0421
132	0.173	1.101	18.12	7.5	-2.1050	-2.7059	-0.3813	-0.0217	0.9967	0.2117	-0.7512	0.0433
133	0.162	1.149	18.14	7.5	-2.1346	-2.5916	-0.3693	-0.0276	0.9895	0.2242	-0.8536	0.0391
134	0.163	1.199	18.17	7.5	-2.1569	-2.2513	-0.3950	-0.0221	1.0271	0.1684	-0.6479	0.0460
137	0.145	0.950	20.10	7.5	-2.5205	-3.1995	-0.1207	-0.0067	0.9046	0.2001	-0.7034	0.0559
138	0.149	0.999	20.13	7.5	-2.5293	-3.3052	-0.1716	-0.0133	1.0191	0.2282	-0.8453	0.0423
139	0.165	1.050	20.15	7.5	-2.5215	-2.9530	-0.3372	-0.0063	1.1795	0.2462	-0.8648	0.0491
140	0.154	1.101	20.16	7.5	-2.5205	-2.9170	-0.3735	-0.0245	1.1966	0.2042	-0.8042	0.0547
141	0.173	1.149	20.18	7.5	-2.5709	-2.8072	-0.3590	-0.0251	1.2006	0.2068	-0.8343	0.0543
142	0.176	1.198	20.22	7.5	-2.6045	-2.4331	-0.3923	-0.0202	1.2496	0.1918	-0.7397	0.0608
143	0.145	0.949	22.14	7.5	-2.8041	-3.5526	-0.0973	-0.0103	1.1376	0.1850	-0.6371	0.0649
144	0.149	1.000	22.18	7.5	-3.0477	-3.5349	-0.1420	-0.0142	1.2692	0.2599	-0.9280	0.0579
145	0.152	1.051	22.21	7.5	-3.0516	-3.2396	-0.3319	-0.0089	1.4527	0.2656	-0.9502	0.0600
146	0.155	1.100	22.22	7.5	-3.0150	-3.1723	-0.3584	-0.0231	1.4507	0.2592	-0.9321	0.0667
147	0.158	1.150	22.25	7.5	-3.0687	-2.9692	-0.3525	-0.0240	1.4661	0.2366	-0.9264	0.0668
148	0.162	1.200	22.29	7.5	-3.1142	-2.5825	-0.3802	-0.0203	1.5146	0.1933	-0.7141	0.0778
149	0.160	0.952	24.20	7.5	-3.4034	-3.9118	-0.0735	-0.0112	1.4520	0.2179	-0.8020	0.0784
150	0.149	1.002	24.25	7.5	-3.5677	-3.5695	-0.1376	-0.0127	1.5794	0.2609	-1.0376	0.0696
151	0.167	1.050	24.27	7.5	-3.6069	-3.4898	-0.3251	-0.0094	1.7707	0.2095	-0.8617	0.0691
152	0.155	1.100	24.29	7.5	-3.5881	-3.4074	-0.3511	-0.0239	1.7744	0.2447	-0.8944	0.0798

TABLE 1.08
DATA LISTINGS

ROLL ANGLE = 7.5 DEG.

SER	REYN	MACH	THETA	RANG	NORMAL	PITCH	AXIAL	BASE	DRAG	SIDE F	YAW M	ROLL M
153	0.158	1.150	24.33	7.5	-3.6116	-3.1641	-0.3376	-0.0259	1.7716	0.2880	-1.0172	0.0765
154	0.178	1.198	24.37	7.5	-3.6604	-2.7805	-0.3591	-0.0221	1.8174	0.2334	-0.8484	0.0808
155	0.145	0.949	26.25	7.5	-3.8775	-4.0126	-0.0387	-0.0116	1.7395	0.3911	-1.2492	0.0860
156	0.149	0.999	26.32	7.5	-4.0563	-3.5676	-0.1172	-0.0163	1.8889	0.3914	-1.3143	0.0732
157	0.155	1.052	26.35	7.5	-4.1122	-3.5758	-0.3075	-0.0190	2.0835	0.3125	-1.0334	0.0742
158	0.155	1.101	26.36	7.5	-4.1319	-3.6191	-0.3205	-0.0270	2.0976	0.2608	-0.9643	0.0865
159	0.162	1.151	26.40	7.5	-4.1690	-3.3009	-0.3235	-0.0268	2.1196	0.2863	-1.0534	0.0831
160	0.163	1.200	26.45	7.5	-4.2096	-2.9488	-0.3558	-0.0228	2.1732	0.2405	-0.8654	0.0863
161	0.160	0.949	28.32	7.5	-4.3698	-4.0059	-0.0128	-0.0122	2.0735	0.3703	-1.1360	0.0995
162	0.163	1.002	28.40	7.5	-4.5697	-3.4788	-0.1011	-0.0175	2.2468	0.5073	-1.5448	0.0758
163	0.170	1.049	28.42	7.5	-4.6525	-3.6280	-0.2880	-0.0208	2.4492	0.4411	-1.3071	0.0777
164	0.158	1.098	28.44	7.5	-4.6886	-3.6930	-0.3149	-0.0284	2.4848	0.2529	-0.8798	0.0898
165	0.162	1.150	28.48	7.5	-4.7076	-3.4116	-0.2931	-0.0267	2.4792	0.2601	-0.9652	0.0908
166	0.180	1.200	28.52	7.5	-4.7464	-3.1562	-0.3312	-0.0224	2.5378	0.2851	-0.9092	0.0901

TABLE 1.09

DATA LISTINGS

ROLL ANGLE = 15 DEG.

SER	REYN	MACH	THETA	RANG	NORMAL	PITCH	AXIAL	BASE	DRAG	SIDE F	YAW M	ROLL M
2	0.145	0.948	-2.01	15.0	0.1100	0.0881	-0.1540	0.0106	0.1683	0.0244	-0.0531	0.0174
3	0.121	1.000	-2.01	15.0	0.1196	0.1133	-0.1839	0.0065	0.1944	0.0242	-0.0289	0.0175
4	0.155	1.050	-2.02	15.0	0.1088	0.0445	-0.3256	0.0127	0.3419	0.0047	0.0276	0.0165
5	0.158	1.100	-2.02	15.0	0.1166	0.0660	-0.3524	-0.0044	0.3518	0.0133	-0.0261	0.0173
6	0.162	1.150	-2.02	15.0	0.1262	0.1040	-0.3487	-0.0099	0.3430	0.0198	-0.0616	0.0176
7	0.163	1.199	-2.02	15.0	0.1467	0.1597	-0.3736	-0.0075	0.3709	-0.0016	0.0327	0.0171
8	0.147	0.950	0.01	15.0	-0.0261	-0.0588	-0.1572	0.0064	0.1636	0.0099	-0.0160	0.0169
9	0.152	1.000	-0.01	15.0	-0.0306	-0.0750	-0.1908	0.0061	0.1968	0.0079	-0.0065	0.0168
10	0.155	1.048	-0.01	15.0	-0.0320	-0.0964	-0.3157	0.0103	0.3259	0.0084	0.0093	0.0168
12	0.158	1.100	-0.01	15.0	-0.0340	-0.1196	-0.3648	-0.0062	0.3586	0.0113	-0.0087	0.0173
13	0.178	1.151	-0.01	15.0	-0.0305	-0.0846	-0.3477	-0.0103	0.3373	0.0146	-0.0595	0.0177
14	0.180	1.200	0.01	15.0	-0.0106	-0.0097	-0.3653	-0.0080	0.3573	-0.0074	0.0553	0.0173
15	0.147	0.950	2.00	15.0	-0.1667	-0.2170	-0.1634	0.0039	0.1730	0.0107	-0.0364	0.0177
16	0.152	0.999	2.00	15.0	-0.1809	-0.2731	-0.1996	0.0060	0.2117	0.0192	-0.0272	0.0178
17	0.172	1.049	2.01	15.0	-0.1776	-0.2233	-0.3168	0.0111	0.3339	0.0084	-0.0058	0.0162
18	0.173	1.099	2.00	15.0	-0.1937	-0.2985	-0.3631	-0.0013	0.3683	0.0136	-0.0333	0.0178
19	0.178	1.149	2.01	15.0	-0.1855	-0.2702	-0.3473	-0.0071	0.3464	0.0216	-0.0052	0.0172
20	0.163	1.201	2.01	15.0	-0.1711	-0.1878	-0.3697	-0.0077	0.3677	-0.0108	0.0593	0.0181
21	0.163	0.951	4.01	15.0	-0.3195	-0.4156	-0.1597	0.0024	0.1840	0.0251	-0.0075	0.0198
22	0.152	1.002	4.01	15.0	-0.3492	-0.5059	-0.1946	0.0020	0.2205	0.0275	-0.0637	0.0199
23	0.172	1.051	4.02	15.0	-0.3418	-0.4207	-0.3116	0.0069	0.3416	0.0115	-0.0262	0.0190
24	0.162	1.098	4.02	15.0	-0.3617	-0.5255	-0.3566	-0.0049	0.3761	0.0230	-0.0771	0.0203
25	0.163	1.148	4.02	15.0	-0.3561	-0.4886	-0.3587	-0.0111	0.3717	0.0321	-0.1245	0.0205
26	0.180	1.199	4.02	15.0	-0.3401	-0.3923	-0.3846	-0.0093	0.3982	-0.0065	0.0259	0.0195
27	0.163	0.949	6.02	15.0	-0.5012	-0.6972	-0.1646	0.0038	0.2200	0.0379	-0.1424	0.0241
28	0.152	0.909	6.02	15.0	-0.5404	-0.7951	-0.2060	0.0036	0.2651	0.0389	-0.1746	0.0241
29	0.157	1.049	6.03	15.0	-0.5305	-0.6763	-0.3263	0.0091	0.3892	0.0226	-0.1029	0.0203
30	0.162	1.097	6.02	15.0	-0.5503	-0.8053	-0.3642	-0.0037	0.4163	0.0462	-0.1689	0.0228
31	0.178	1.148	6.03	15.0	-0.5423	-0.7536	-0.3562	-0.0131	0.3982	0.0490	-0.1942	0.0224
32	0.183	1.198	6.04	15.0	-0.5208	-0.6191	-0.3855	-0.0115	0.4267	0.0211	-0.0625	0.0226
33	0.147	0.949	8.03	15.0	-0.7083	-1.0409	-0.1602	0.0003	0.2578	0.0658	-0.2753	0.0259
34	0.154	0.999	8.03	15.0	-0.7452	-1.1213	-0.2049	0.0013	0.3082	0.0794	-0.3199	0.0256
35	0.157	1.051	8.04	15.0	-0.7461	-1.0188	-0.3360	0.0100	0.4468	0.0591	-0.2160	0.0220
36	0.178	1.100	8.04	15.0	-0.7586	-1.0923	-0.3761	-0.0084	0.4701	0.0667	-0.2758	0.0250
37	0.163	1.149	8.04	15.0	-0.7490	-1.0536	-0.3609	-0.0161	0.4461	0.0797	-0.3136	0.0246
38	0.167	1.198	8.05	15.0	-0.7210	-0.8553	-0.3974	-0.0164	0.4782	0.0458	-0.1650	0.0232
41	0.157	0.950	10.03	15.0	-0.9219	-1.3875	-0.1437	0.0051	0.3071	0.1057	-0.4136	0.0283
42	0.145	1.000	10.04	15.0	-0.9700	-1.4589	-0.2022	-0.0007	0.3674	0.1093	-0.4510	0.0268
43	0.165	1.048	10.05	15.0	-0.9650	-1.3194	-0.3402	0.0079	0.5111	0.0933	-0.3474	0.0241
44	0.154	1.101	10.04	15.0	-0.9738	-1.3950	-0.3745	-0.0120	0.5267	0.1037	-0.4074	0.0245
45	0.157	1.149	10.05	15.0	-0.9677	-1.3472	-0.3662	-0.0170	0.5126	0.1193	-0.4447	0.0244

TABLE 1.09

DATA LISTINGS

ROLL ANGLE = 15 DEG.

SER	REYN	MACH	THETA	RANG	NORMAL	PITCH	AXIAL	BASE	DRAG	SIDE F	YAW M	ROLL M
46	0.160	1.198	10.06	15.0	-0.9375	-1.1117	-0.4052	-0.00173	0.5457	0.0767	-0.2751	0.0240
47	0.142	0.952	12.04	15.0	-1.1565	-1.7327	-0.1553	-0.00226	0.3906	0.1631	-0.6249	0.0325
48	0.162	0.999	12.04	15.0	-1.2163	-1.8334	-0.1950	-0.0028	0.4417	0.1732	-0.6575	0.0276
49	0.150	1.051	12.06	15.0	-1.2025	-1.6353	-0.3483	0.0032	0.5950	0.1496	-0.5078	0.0265
50	0.154	1.100	12.06	15.0	-1.2192	-1.7238	-0.3785	-0.0188	0.6064	0.1694	-0.6250	0.0288
51	0.172	1.148	12.06	15.0	-1.2130	-1.6423	-0.3717	-0.0187	0.5987	0.1732	-0.7088	0.0278
52	0.162	1.202	12.08	15.0	-1.1791	-1.3753	-0.4090	-0.0174	0.6297	0.1348	-0.5052	0.0295
53	0.142	0.949	14.05	15.0	-1.4018	-2.0724	-0.1421	-0.0051	0.4732	0.1998	-0.7907	0.0397
54	0.149	0.999	14.06	15.0	-1.4780	-2.1602	-0.1907	-0.0055	0.5387	0.2158	-0.8295	0.0308
55	0.152	1.051	14.07	15.0	-1.4624	-1.9182	-0.3647	-0.0010	0.7084	0.1962	-0.7322	0.0347
56	0.154	1.099	14.07	15.0	-1.4710	-2.0059	-0.3781	-0.0153	0.7096	0.2244	-0.8523	0.0352
57	0.157	1.152	14.09	15.0	-1.4646	-1.8861	-0.3720	-0.0203	0.6976	0.2257	-0.9273	0.0350
58	0.162	1.200	14.10	15.0	-1.4295	-1.5863	-0.4080	-0.0168	0.7278	0.1845	-0.6840	0.0342
59	0.157	0.950	16.07	15.0	-1.6541	-2.3941	-0.1368	-0.0062	0.5832	0.2451	-0.9053	0.0511
60	0.162	0.999	16.08	15.0	-1.7469	-2.5034	-0.1767	-0.0042	0.6495	0.2629	-0.9447	0.0374
61	0.168	1.048	16.10	15.0	-1.7186	-2.1175	-0.3486	0.0012	0.8128	0.2420	-0.8397	0.0439
62	0.155	1.101	16.10	15.0	-1.7351	-2.2302	-0.3750	-0.0146	0.8274	0.2646	-1.0270	0.0445
63	0.157	1.148	16.11	15.0	-1.7441	-2.1219	-0.3707	-0.0191	0.8218	0.2796	-1.0673	0.0419
64	0.162	1.200	16.14	15.0	-1.7350	-1.7966	-0.4069	-0.0184	0.8554	0.2221	-0.8375	0.0421
65	0.144	0.951	18.08	15.0	-1.9240	-2.6786	-0.1245	-0.0159	0.7005	0.2459	-0.9129	0.0659
66	0.163	1.000	18.10	15.0	-2.0621	-2.7920	-0.1801	-0.0109	0.8014	0.2674	-1.0317	0.0433
67	0.168	1.048	18.13	15.0	-2.0262	-2.3063	-0.3377	-0.0059	0.9459	0.2546	-0.9318	0.0520
68	0.155	1.101	18.14	15.0	-2.0598	-2.4482	-0.3803	-0.0136	0.9895	0.2783	-1.1069	0.0539
69	0.158	1.151	18.15	15.0	-2.0890	-2.3386	-0.3744	-0.0219	0.9857	0.2889	-1.1562	0.0486
70	0.162	1.202	18.19	15.0	-2.1065	-1.9895	-0.3933	-0.0195	1.0125	0.2574	-0.9967	0.0572
71	0.145	0.950	20.11	15.0	-2.2942	-2.9972	-0.1300	-0.0104	0.9013	0.2013	-0.8240	0.0804
72	0.149	0.997	20.14	15.0	-2.4602	-3.0151	-0.1651	-0.0119	0.9909	0.2974	-1.1263	0.0626
73	0.152	1.050	20.17	15.0	-2.4584	-2.5930	-0.3360	-0.0039	1.1596	0.2739	-1.0331	0.0672
74	0.157	1.099	20.18	15.0	-2.4588	-2.7017	-0.3686	-0.0102	1.1844	0.3123	-1.2186	0.0652
75	0.158	1.148	20.21	15.0	-2.5223	-2.5634	-0.3492	-0.0180	1.1818	0.3039	-1.2201	0.0636
76	0.162	1.198	20.25	15.0	-2.5582	-2.1711	-0.3806	-0.0169	1.2264	0.2575	-1.0081	0.0747
2	0.144	0.950	22.15	15.0	-2.7948	-3.2660	-0.0921	-0.0030	1.1365	0.2109	-0.8361	0.0945
3	0.162	1.001	22.19	15.0	-2.9984	-3.1124	-0.1523	-0.0128	1.2619	0.3420	-1.3044	0.0772
4	0.165	1.050	22.22	15.0	-2.9853	-2.8020	-0.3162	-0.0086	1.4140	0.3210	-1.2333	0.0844
5	0.170	1.101	22.23	15.0	-2.9663	-2.8997	-0.3566	-0.0232	1.4307	0.2961	-1.1776	0.0844
6	0.157	1.152	22.27	15.0	-3.0334	-2.6675	-0.3436	-0.0244	1.4447	0.2933	-1.1995	0.0819
7	0.160	1.198	22.31	15.0	-3.0569	-2.2751	-0.3727	-0.0218	1.4849	0.2499	-0.9809	0.0920
8	0.142	0.950	24.21	15.0	-3.3147	-3.4127	-0.0774	-0.0168	1.4148	0.2442	-1.0035	0.1115
9	0.149	0.999	24.26	15.0	-3.4733	-3.1499	-0.1299	-0.0159	1.5310	0.3620	-1.4240	0.0987
10	0.150	1.048	24.29	15.0	-3.4874	-2.9249	-0.3096	-0.0082	1.7092	0.3251	-1.2809	0.1048
11	0.170	1.100	24.30	15.0	-3.5367	-3.1060	-0.3381	-0.0197	1.7457	0.2967	-1.2062	0.1000

TABLE 1.09
 DATA LISTINGS
 ROLL ANGLE = 15 DEG.

SER	REYN	MACH	THETA	RANG	NORMAL	PITCH	AXIAL	BASE	DRAG	SIDE F	YAW M	ROLL M
12	0.173	1.151	24.33	15.0	-3.5667	-2.8425	-0.3316	-0.0302	1.7444	0.3255	-1.3135	0.0943
13	0.162	1.272	24.38	15.0	-3.6039	-2.4544	-0.3594	-0.0239	1.7920	0.2907	-1.1016	0.1023
14	0.142	0.950	26.27	15.0	-3.7439	-3.4479	-0.2613	-0.0228	1.6913	0.3133	-1.1810	0.1213
15	0.149	1.002	26.32	15.0	-3.7199	-3.0610	-0.1158	-0.0205	1.8238	0.4751	-1.6832	0.1085
16	0.152	1.048	26.36	15.0	-3.9988	-3.0574	-0.3071	-0.0140	2.0377	0.4187	-1.4792	0.1189
17	0.155	1.102	26.37	15.0	-4.0475	-3.2462	-0.3232	-0.0303	2.0601	0.3978	-1.3908	0.1088
18	0.158	1.151	26.41	15.0	-4.1055	-3.0017	-0.3173	-0.0276	2.0855	0.2967	-1.2507	0.1059
19	0.162	1.200	26.45	15.0	-4.1555	-2.6830	-0.3431	-0.0267	2.1346	0.2956	-1.1095	0.1082
20	0.145	0.948	28.34	15.0	-4.2487	-3.3815	-0.0286	-0.0162	2.0274	0.3749	-1.2955	0.1355
21	0.149	0.998	28.41	15.0	-4.4484	-3.0214	-0.1017	-0.0191	2.1884	0.5414	-1.6435	0.1168
22	0.152	1.049	28.42	15.0	-4.5519	-3.1846	-0.2883	-0.0181	2.4045	0.4486	-1.5402	0.1279
23	0.157	1.098	28.45	15.0	-4.6081	-3.3846	-0.3159	-0.0241	2.4513	0.4031	-1.4312	0.1195
24	0.175	1.151	28.48	15.0	-4.6352	-3.1718	-0.2835	-0.0298	2.4334	0.4034	-1.4633	0.1135
25	0.162	1.198	28.53	15.0	-4.6916	-2.8438	-0.3201	-0.0254	2.4997	0.3051	-1.0779	0.1140

TABLE 1.10
DATA LISTINGS

ROLL ANGLE = 22,5 DEG.

SER	REYN	MACH	THETA	RANG	NORMAL	PITCH	AXIAL	BASE	DRAG	SIDE F	YAW M	ROLL M
2	0.139	0.951	-2.01	22.5	0.1053	0.0733	-0.1564	0.0059	0.1658	0.0144	-0.0219	0.0179
3	0.158	0.998	-2.02	22.5	0.1101	0.0953	-0.1723	0.0049	0.1808	0.0148	-0.0065	0.0172
4	0.147	1.050	-2.02	22.5	0.1101	0.0431	-0.3200	0.0043	0.3279	0.0153	0.0093	0.0187
5	0.165	1.100	-2.02	22.5	0.1139	0.0706	-0.3528	-0.0070	0.3495	0.0226	-0.0275	0.0182
6	0.155	1.149	-2.01	22.5	0.1242	0.1017	-0.3460	-0.0080	0.3422	0.0237	-0.0781	0.0171
7	0.157	1.200	-2.02	22.5	0.1451	0.1605	-0.3690	-0.0086	0.3652	-0.0028	0.0335	0.0186
8	0.142	0.951	0.01	22.5	-0.0235	-0.0554	-0.1559	0.0058	0.1617	0.0215	-0.0322	0.0174
9	0.145	1.000	0.00	22.5	-0.0306	-0.0674	-0.1928	0.0055	0.1982	0.0013	-0.0035	0.0164
10	0.150	1.049	-0.01	22.5	-0.0288	-0.0883	-0.3104	0.0112	0.3215	0.0070	-0.0078	0.0165
11	0.154	1.101	-0.01	22.5	-0.0383	-0.1149	-0.3506	-0.0045	0.3461	0.0101	-0.0026	0.0161
12	0.155	1.148	-0.01	22.5	-0.0321	-0.0813	-0.3594	-0.0107	0.3487	0.0153	-0.0659	0.0181
13	0.157	1.199	0.01	22.5	-0.0083	-0.0096	-0.3700	-0.0094	0.3606	-0.0022	0.0433	0.0168
14	0.142	0.950	2.00	22.5	-0.1649	-0.2084	-0.1604	0.0062	0.1722	0.0127	-0.0222	0.0165
15	0.147	0.998	2.00	22.5	-0.1821	-0.2573	-0.1880	0.0055	0.1997	0.0155	-0.0431	0.0181
16	0.150	1.048	2.00	22.5	-0.1758	-0.2179	-0.3099	0.0131	0.3289	0.0059	0.0067	0.0171
17	0.154	1.100	2.00	22.5	-0.1928	-0.2966	-0.3463	-0.0063	0.3465	0.0120	-0.0329	0.0184
18	0.157	1.150	2.00	22.5	-0.1840	-0.2625	-0.3544	-0.0097	0.3509	0.0225	-0.0752	0.0183
19	0.160	1.198	2.01	22.5	-0.1614	-0.1654	-0.3650	-0.0093	0.3610	-0.0008	0.0223	0.0180
20	0.142	0.948	4.00	22.5	-0.3100	-0.3855	-0.1719	0.0025	0.1956	0.0308	-0.0788	0.0199
21	0.162	1.001	4.00	22.5	-0.3439	-0.4759	-0.2016	0.0030	0.2282	0.0274	-0.0746	0.0196
22	0.150	1.049	4.01	22.5	-0.3241	-0.3480	-0.3090	0.0055	0.3364	0.0220	-0.0305	0.0180
23	0.154	1.099	4.01	22.5	-0.3565	-0.5000	-0.3596	-0.0063	0.3774	0.0282	-0.0657	0.0198
24	0.173	1.151	4.02	22.5	-0.3492	-0.4656	-0.3483	-0.0120	0.3599	0.0271	-0.1294	0.0204
25	0.175	1.202	4.01	22.5	-0.3312	-0.3601	-0.3781	-0.0101	0.3902	0.0084	-0.0037	0.0190
26	0.157	0.949	6.02	22.5	-0.4800	-0.6208	-0.1583	0.0036	0.2113	0.0465	-0.1821	0.0229
29	0.145	1.000	6.02	22.5	-0.5184	-0.7274	-0.1945	0.0010	0.2488	0.0504	-0.1632	0.0236
30	0.150	1.050	6.02	22.5	-0.5124	-0.6262	-0.3357	0.0095	0.3970	0.0438	-0.1187	0.0192
31	0.154	1.101	6.02	22.5	-0.5311	-0.7376	-0.3596	-0.0063	0.4071	0.0505	-0.1598	0.0219
32	0.157	1.150	6.02	22.5	-0.5258	-0.6935	-0.3513	-0.0115	0.3930	0.0629	-0.2373	0.0213
33	0.160	1.199	6.03	22.5	-0.5045	-0.5407	-0.3852	-0.0111	0.4250	0.0174	-0.0578	0.0209
34	0.142	0.951	8.03	22.5	-0.6724	-0.9155	-0.1501	0.0010	0.2435	0.0851	-0.3148	0.0259
35	0.147	1.000	8.03	22.5	-0.7129	-1.0068	-0.1998	-0.0014	0.2960	0.0862	-0.3232	0.0247
36	0.150	1.049	8.04	22.5	-0.6934	-0.8118	-0.3042	0.0065	0.4045	0.0677	-0.2349	0.0214
37	0.154	1.100	8.04	22.5	-0.7258	-0.9789	-0.3713	-0.0075	0.4617	0.0830	-0.3179	0.0238
38	0.157	1.150	8.04	22.5	-0.7144	-0.9250	-0.3590	-0.0132	0.4422	0.0995	-0.3730	0.0233
39	0.176	1.199	8.05	22.5	-0.6925	-0.7444	-0.3859	-0.0136	0.4655	0.0549	-0.1827	0.0218
40	0.142	0.949	10.03	22.5	-0.8798	-1.2043	-0.1536	-0.0011	0.3033	0.1314	-0.4798	0.0269
41	0.162	0.999	10.03	22.5	-0.9257	-1.3028	-0.2006	-0.0011	0.3579	0.1285	-0.4877	0.0256
42	0.167	1.051	10.05	22.5	-0.9281	-1.1630	-0.3406	0.0045	0.5017	0.1109	-0.4006	0.0232
43	0.157	1.098	10.05	22.5	-0.9291	-1.2228	-0.3737	-0.0109	0.5193	0.1403	-0.4790	0.0256
44	0.157	1.148	10.06	22.5	-0.9292	-1.1848	-0.3667	-0.0158	0.5076	0.1342	-0.5194	0.0242

TABLE 1.10
DATA LISTINGS
ROLL ANGLE = 22.5 DEG.

SER	REYN	MACH	THETA	RANG	NORMAL	PITCH	AXIAL	BASE	DRAG	SIDE F	YAW M	ROLL M
45	0.176	1.199	10.07	22.5	-0.8984	-0.9457	-0.3922	-0.0164	0.5271	0.0851	-0.3074	0.0225
46	0.144	0.951	12.04	22.5	-1.1012	-1.5091	-0.1490	-0.0029	0.3727	0.1888	-0.6925	0.0304
47	0.149	1.001	12.06	22.5	-1.1541	-1.5985	-0.1950	-0.0017	0.4300	0.2011	-0.7352	0.0276
48	0.152	1.050	12.07	22.5	-1.1596	-1.4424	-0.3537	0.0058	0.5939	0.1692	-0.6058	0.0268
49	0.157	1.098	12.07	22.5	-1.1608	-1.4809	-0.3838	0.0136	0.6046	0.1874	-0.7003	0.0279
50	0.158	1.149	12.07	22.5	-1.1600	-1.4307	-0.3728	-0.0172	0.5903	0.1875	-0.7141	0.0281
51	0.162	1.199	12.09	22.5	-1.1251	-1.1725	-0.3953	-0.0169	0.6057	0.1472	-0.5002	0.0289
52	0.144	0.951	14.06	22.5	-1.3367	-1.8107	-0.1445	-0.0036	0.4614	0.2400	-0.8647	0.0385
53	0.149	0.998	14.07	22.5	-1.4020	-1.8914	-0.1903	-0.0048	0.5207	0.2578	-0.9501	0.0318
54	0.152	1.048	14.09	22.5	-1.3970	-1.6321	-0.3312	0.0061	0.6671	0.1976	-0.7249	0.0349
55	0.155	1.101	14.09	22.5	-1.4075	-1.7283	-0.3698	-0.0135	0.6881	0.2292	-0.8825	0.0356
56	0.158	1.149	14.09	22.5	-1.4046	-1.6375	-0.3769	-0.0192	0.6890	0.2364	-0.9583	0.0367
57	0.178	1.202	14.11	22.5	-1.3823	-1.3567	-0.4112	-0.0179	0.7185	0.1936	-0.7447	0.0390
58	0.147	0.952	16.07	22.5	-1.5798	-2.0940	-0.1368	-0.0057	0.5634	0.2629	-0.9313	0.0529
59	0.163	1.020	16.08	22.5	-1.6776	-2.2016	-0.1791	-0.0084	0.6288	0.2907	-1.0785	0.0403
60	0.152	1.049	16.12	22.5	-1.6519	-1.8306	-0.3460	0.0028	0.7935	0.2453	-0.8851	0.0467
61	0.157	1.098	16.11	22.5	-1.6651	-1.9452	-0.3681	-0.0153	0.8009	0.2813	-1.0658	0.0455
62	0.158	1.152	16.13	22.5	-1.6701	-1.8081	-0.3665	-0.0196	0.7970	0.2887	-1.1293	0.0455
63	0.163	1.201	16.15	22.5	-1.6694	-1.5086	-0.3954	-0.0184	0.8266	0.2243	-0.8975	0.0524
66	0.139	0.950	18.09	22.5	-1.8532	-2.3723	-0.1230	-0.0064	0.6862	0.2529	-0.9196	0.0724
67	0.144	0.998	18.10	22.5	-1.9792	-2.4516	-0.1583	-0.0120	0.7541	0.2825	-1.0766	0.0536
68	0.147	1.050	18.13	22.5	-1.9667	-2.0534	-0.3364	-0.0010	0.9308	0.2523	-0.9125	0.0610
69	0.152	1.099	18.14	22.5	-1.9720	-2.1508	-0.3572	-0.0185	0.9356	0.2990	-1.1460	0.0618
70	0.154	1.151	18.16	22.5	-2.0145	-2.0092	-0.3491	-0.0232	0.9373	0.3016	-1.2233	0.0581
71	0.157	1.201	18.19	22.5	-2.0365	-1.6929	-0.3918	-0.0189	0.9899	0.2517	-0.9694	0.0659
72	0.142	0.949	20.12	22.5	-2.2222	-2.6434	-0.1206	-0.0096	0.8686	0.2515	-0.9391	0.0879
73	0.147	0.999	20.14	22.5	-2.3779	-2.6102	-0.1609	-0.0143	0.9567	0.3077	-1.1750	0.0678
74	0.150	1.052	20.18	22.5	-2.3914	-2.3000	-0.3404	-0.0047	1.1400	0.2559	-0.9820	0.0746
75	0.154	1.099	20.18	22.5	-2.3961	-2.3463	-0.3551	-0.0183	1.1427	0.2883	-1.1268	0.0756
76	0.157	1.152	20.21	22.5	-2.4506	-2.1913	-0.3634	-0.0245	1.1646	0.3043	-1.2059	0.0738
77	0.157	1.198	20.24	22.5	-2.4890	-1.8375	-0.3836	-0.0193	1.2032	0.2322	-0.9171	0.0809
78	0.142	0.952	22.17	22.5	-2.7012	-2.7719	-0.1032	-0.0128	1.1030	0.2789	-1.0469	0.1023
79	0.145	1.001	22.21	22.5	-2.8839	-2.6853	-0.1499	-0.0173	1.2129	0.3440	-1.3216	0.0874
80	0.150	1.050	22.25	22.5	-2.8682	-2.3140	-0.3104	-0.0073	1.3663	0.2874	-1.0863	0.0956
81	0.154	1.099	22.25	22.5	-2.9029	-2.5104	-0.3460	-0.0214	1.3994	0.3026	-1.1969	0.0892
82	0.157	1.150	22.27	22.5	-2.9413	-2.3117	-0.3529	-0.0226	1.4205	0.3099	-1.2132	0.0838
83	0.160	1.202	22.31	22.5	-2.9775	-1.9319	-0.3769	-0.0221	1.4590	0.2563	-0.9997	0.0928
84	0.142	0.950	24.23	22.5	-3.1816	-2.8372	-0.0783	-0.0157	1.3627	0.3718	-1.3079	0.1157
85	0.145	1.000	24.28	22.5	-3.3587	-2.6152	-0.1305	-0.0172	1.4842	0.4179	-1.5628	0.1035
86	0.165	1.048	24.31	22.5	-3.3614	-2.3173	-0.3073	-0.0108	1.6541	0.3130	-1.2045	0.1153
87	0.154	1.099	24.32	22.5	-3.4312	-2.6849	-0.3405	-0.0247	1.7005	0.3316	-1.2790	0.1052

TABLE 1.10

DATA LISTINGS

ROLL ANGLE = 22,5 DEG.

SER	REYN	MACH	THETA	RANG	NORMAL	PITCH	AXIAL	BASE	DRAG	SIDE F	YAW M	ROLL M
88	0,157	1,149	24,35	22,5	-3,4751	-2,4773	-0,3332	-0,0279	1,7108	0,3479	-1,2746	0,0949
89	0,160	1,200	24,39	22,5	-3,5123	-2,1096	-0,3561	-0,0228	1,7540	0,2883	-1,0376	0,0965
90	0,142	0,952	26,28	22,5	-3,5912	-2,8257	-0,0501	-0,0181	1,6189	0,4200	-1,4225	0,1339
91	0,145	1,000	26,34	22,5	-3,7931	-2,6279	-0,1072	-0,0205	1,7604	0,4711	-1,6986	0,1172
92	0,168	1,049	26,37	22,5	-3,8840	-2,5642	-0,3071	-0,0163	1,9859	0,3446	-1,2582	0,1264
93	0,155	1,100	26,38	22,5	-3,9477	-2,8690	-0,3236	-0,0294	2,0175	0,3470	-1,2943	0,1143
94	0,173	1,150	26,42	22,5	-3,9987	-2,6051	-0,3148	-0,0324	2,0321	0,3904	-1,4146	0,1033
95	0,176	1,199	26,47	22,5	-4,0484	-2,2680	-0,3376	-0,0267	2,0026	0,2973	-1,0599	0,1044
96	0,144	0,952	28,35	22,5	-4,0847	-2,8191	-0,0242	-0,0219	1,9415	0,4506	-1,4358	0,1469
97	0,162	0,999	28,42	22,5	-4,3378	-2,5597	-0,0832	-0,0211	2,1187	0,5347	-1,8368	0,1241
98	0,152	1,049	28,45	22,5	-4,4303	-2,6542	-0,2812	-0,0277	2,3332	0,4341	-1,4801	0,1303
99	0,155	1,100	28,46	22,5	-4,5027	-2,9468	-0,3257	-0,0323	2,4035	0,4208	-1,4564	0,1194
100	0,158	1,151	28,50	22,5	-4,5473	-2,7596	-0,2900	-0,0328	2,3955	0,4028	-1,4480	0,1127
101	0,175	1,202	28,54	22,5	-4,6132	-2,5010	-0,3290	-0,0313	2,4660	0,2914	-1,0316	0,1138

TABLE 1.11
DATA LISTINGS
ROLL ANGLE = 30 DEG,

SER	REYN	MACH	THETA	RANG	NORMAL	PITCH	AXIAL	BASE	DRAG	SIDE F	YAW M	ROLL M
41	0.147	0.949	-2.01	30.0	0.1145	0.0851	-0.1541	0.0098	0.1678	0.0131	-0.0155	0.0180
42	0.152	0.998	-2.01	30.0	0.1211	0.1092	-0.1835	0.0065	0.1941	0.0198	-0.0192	0.0185
43	0.157	1.049	-2.02	30.0	0.1074	0.0230	-0.2972	0.0147	0.3154	0.0091	0.0236	0.0175
44	0.160	1.099	-2.02	30.0	0.1204	0.0880	-0.3589	-0.0019	0.3609	0.0211	-0.0195	0.0172
45	0.167	1.150	-2.02	30.0	0.1313	0.1227	-0.3540	-0.0072	0.3511	0.0200	-0.0586	0.0181
46	0.168	1.200	-2.02	30.0	0.1556	0.1792	-0.3637	-0.0070	0.3619	0.0052	0.0158	0.0176
47	0.150	0.949	-0.01	30.0	-0.0216	-0.0429	-0.1604	0.0054	0.1657	0.0052	-0.0221	0.0167
48	0.154	0.999	-0.09	-0.1	-0.0240	-0.0599	-0.1815	0.0085	0.1899	-0.0011	0.0011	0.0176
49	0.157	1.049	-0.01	30.0	-0.0162	-0.0547	-0.3035	0.0116	0.3151	0.0097	-0.0180	0.0151
50	0.163	1.102	-0.01	30.0	-0.0290	-0.1014	-0.3583	-0.0044	0.3539	0.0178	-0.0366	0.0178
51	0.167	1.151	-0.01	30.0	-0.0177	-0.0557	-0.3537	-0.0045	0.3491	0.0179	-0.0422	0.0176
53	0.168	1.199	0.01	30.0	-0.0044	0.0014	-0.3635	-0.0083	0.3551	-0.0036	0.0342	0.0176
54	0.150	0.950	2.00	30.0	-0.1557	-0.1855	-0.1557	0.0082	0.1692	0.0135	-0.0481	0.0180
55	0.157	1.003	2.00	30.0	-0.1721	-0.2424	-0.1804	0.0073	0.1935	0.0119	-0.0350	0.0180
56	0.162	1.052	2.01	30.0	-0.1584	-0.1741	-0.3126	0.0060	0.3239	0.0113	-0.0067	0.0165
57	0.165	1.102	2.00	30.0	-0.1838	-0.2768	-0.3507	0.0054	0.3623	0.0183	-0.0337	0.0175
58	0.168	1.150	2.00	30.0	-0.1797	-0.2416	-0.3477	-0.0088	0.3449	0.0158	-0.0786	0.0189
59	0.172	1.202	2.01	30.0	-0.1554	-0.1579	-0.3602	-0.0085	0.3569	-0.0048	0.0348	0.0181
60	0.155	0.952	4.01	30.0	-0.2983	-0.3499	-0.1606	0.0052	0.1863	0.0250	-0.0849	0.0189
61	0.158	1.000	4.01	30.0	-0.3282	-0.4453	-0.1852	0.0063	0.2139	0.0212	-0.0729	0.0199
62	0.162	1.051	4.02	30.0	-0.3113	-0.3015	-0.3010	0.0126	0.3345	0.0084	-0.0254	0.0169
63	0.168	1.102	4.01	30.0	-0.3458	-0.4711	-0.3574	-0.0054	0.3753	0.0208	-0.0656	0.0199
64	0.173	1.151	4.02	30.0	-0.3400	-0.4241	-0.3513	-0.0081	0.3661	0.0253	-0.1137	0.0203
65	0.176	1.199	4.02	30.0	-0.3148	-0.3167	-0.3611	-0.0090	0.3733	0.0017	-0.0007	0.0185
66	0.155	0.949	6.02	30.0	-0.4634	-0.5616	-0.1417	0.0045	0.1940	0.0438	-0.1566	0.0236
67	0.158	0.999	6.02	30.0	-0.4958	-0.6523	-0.1939	0.0056	0.2503	0.0443	-0.1689	0.0240
68	0.165	1.050	6.03	30.0	-0.4745	-0.4753	-0.3178	0.0125	0.3783	0.0262	-0.0816	0.0182
69	0.168	1.102	6.02	30.0	-0.5118	-0.6492	-0.3553	-0.0060	0.4011	0.0302	-0.1590	0.0231
70	0.173	1.150	6.03	30.0	-0.5083	-0.6229	-0.3547	-0.0112	0.3950	0.0464	-0.1878	0.0224
71	0.175	1.202	6.03	30.0	-0.4826	-0.4768	-0.3802	-0.0083	0.4205	0.0148	-0.0460	0.0205
72	0.155	0.950	8.03	30.0	-0.6351	-0.7769	-0.1580	0.0038	0.2489	0.0691	-0.2572	0.0267
73	0.162	1.000	8.03	30.0	-0.6696	-0.8828	-0.1919	0.0035	0.2870	0.0775	-0.2608	0.0260
74	0.165	1.052	8.04	30.0	-0.6806	-0.7587	-0.3179	0.0136	0.4234	0.0482	-0.1796	0.0233
75	0.170	1.099	8.04	30.0	-0.6914	-0.8464	-0.3657	-0.0080	0.4508	0.0667	-0.2597	0.0237
76	0.173	1.149	8.05	30.0	-0.6903	-0.8092	-0.3640	-0.0145	0.4427	0.0654	-0.2672	0.0254
77	0.178	1.199	8.06	30.0	-0.6542	-0.6170	-0.3853	-0.0123	0.4610	0.0403	-0.1197	0.0231
80	0.147	0.948	10.04	30.0	-0.8307	-1.0284	-0.1373	0.0074	0.2872	0.0969	-0.3739	0.0280
81	0.152	1.002	10.04	30.0	-0.8785	-1.1255	-0.1852	0.0027	0.3382	0.1104	-0.3992	0.0257
82	0.155	1.049	10.05	30.0	-0.8535	-0.8596	-0.3031	0.0105	0.4578	0.0941	-0.3099	0.0250
83	0.158	1.099	10.05	30.0	-0.8863	-1.0416	-0.3679	-0.0095	0.5076	0.1019	-0.3863	0.0257
84	0.163	1.151	10.06	30.0	-0.8948	-1.0291	-0.3609	-0.0139	0.4979	0.0948	-0.3967	0.0253

TABLE 1.11

DATA LISTINGS

ROLL ANGLE = 30 DEG.

SER	REYN	MACH	THETA	RANG	NORMAL	PITCH	AXIAL	BASE	DRAG	SIDE F	YAW M	ROLL M
85	0.167	1.198	10.07	30.0	-0.8615	-0.8031	-0.3907	-0.0149	0.5207	0.0494	-0.1926	0.0231
86	0.147	0.949	12.05	30.0	-1.0413	-1.2922	-0.1402	0.0025	0.3570	0.1468	-0.5495	0.0292
87	0.152	0.998	12.05	30.0	-1.1031	-1.4004	-0.1926	0.0041	0.4228	0.1628	-0.6116	0.0259
88	0.157	1.049	12.07	30.0	-1.0836	-1.1151	-0.3231	0.0117	0.5541	0.1230	-0.4369	0.0247
89	0.162	1.099	12.07	30.0	-1.1092	-1.2848	-0.3675	-0.0094	0.5822	0.1403	-0.5247	0.0251
90	0.167	1.149	12.08	30.0	-1.1162	-1.2520	-0.3689	-0.0132	0.5813	0.1465	-0.5747	0.0279
91	0.168	1.198	12.09	30.0	-1.0885	-1.0091	-0.3990	-0.0142	0.6043	0.1034	-0.3716	0.0280
92	0.150	0.954	14.06	30.0	-1.2751	-1.5650	-0.1383	0.0007	0.4447	0.1826	-0.6880	0.0319
94	0.154	0.998	14.08	30.0	-1.3439	-1.6752	-0.1773	-0.0021	0.4967	0.2037	-0.7724	0.0291
95	0.158	1.048	14.10	30.0	-1.2741	-1.1366	-0.2887	0.0055	0.5957	0.1751	-0.6058	0.0241
96	0.163	1.099	14.09	30.0	-1.3516	-1.5151	-0.3699	-0.0118	0.6764	0.1746	-0.6756	0.0307
97	0.167	1.150	14.10	30.0	-1.3530	-1.4383	-0.3582	-0.0145	0.6629	0.1927	-0.7447	0.0335
98	0.168	1.199	14.12	30.0	-1.3227	-1.1476	-0.3863	-0.0126	0.6850	0.1467	-0.5363	0.0340
99	0.150	0.950	16.08	30.0	-1.5092	-1.8142	-0.1281	-0.0008	0.5404	0.2176	-0.7785	0.0420
100	0.154	0.999	16.09	30.0	-1.6047	-1.9557	-0.1578	-0.0028	0.5937	0.2348	-0.8964	0.0339
101	0.160	1.049	16.12	30.0	-1.5751	-1.5139	-0.3183	0.0083	0.7511	0.1960	-0.7279	0.0404
102	0.163	1.098	16.12	30.0	-1.6095	-1.6944	-0.3658	-0.0117	0.7870	0.2233	-0.8816	0.0395
103	0.168	1.150	16.13	30.0	-1.6139	-1.5986	-0.3660	-0.0206	0.7802	0.2486	-0.9351	0.0445
104	0.172	1.199	16.16	30.0	-1.5941	-1.2508	-0.3826	-0.0159	0.7958	0.1974	-0.7531	0.0459
105	0.152	0.948	18.10	30.0	-1.7602	-2.0586	-0.1261	-0.0050	0.6620	0.2297	-0.8457	0.0608
106	0.157	1.001	18.12	30.0	-1.8957	-2.1673	-0.1641	-0.0071	0.7388	0.2413	-0.9139	0.0464
107	0.163	1.049	18.15	30.0	-1.8293	-1.5222	-0.3222	0.0038	0.8798	0.2242	-0.7879	0.0530
108	0.165	1.100	18.16	30.0	-1.8941	-1.8335	-0.3553	-0.0143	0.9141	0.2690	-1.0227	0.0525
109	0.168	1.149	18.17	30.0	-1.9347	-1.7341	-0.3590	-0.0222	0.9234	0.2604	-1.0010	0.0545
110	0.173	1.199	18.20	30.0	-1.9564	-1.3858	-0.3895	-0.0172	0.9650	0.2204	-0.8563	0.0542
113	0.145	0.948	20.12	30.0	-2.0884	-2.2788	-0.1218	-0.0060	0.8271	0.2523	-0.9801	0.0744
114	0.152	1.000	20.15	30.0	-2.2685	-2.3363	-0.1504	-0.0092	0.9140	0.2522	-0.9560	0.0643
115	0.155	1.052	20.18	30.0	-2.2717	-1.9140	-0.3341	-0.0047	1.0930	0.2081	-0.7711	0.0729
116	0.158	1.098	20.18	30.0	-2.5113	-2.0660	-0.3518	-0.0166	1.1123	0.2291	-0.9184	0.0649
117	0.162	1.150	20.21	30.0	-2.3551	-1.9165	-0.3539	-0.0240	1.1232	0.2647	-1.0344	0.0663
118	0.167	1.200	20.25	30.0	-2.3943	-1.4993	-0.3812	-0.0176	1.1700	0.1865	-0.7686	0.0724
119	0.147	0.949	22.17	30.0	-2.2265	-2.4325	-0.1038	-0.0081	1.0419	0.2230	-0.9136	0.0918
120	0.152	0.999	22.21	30.0	-2.7375	-2.4607	-0.1388	-0.0142	1.1499	0.2490	-1.0388	0.0768
121	0.157	1.050	22.25	30.0	-2.6979	-1.7545	-0.3088	-0.0112	1.2972	0.2069	-0.8329	0.0793
122	0.160	1.099	22.24	30.0	-2.7792	-2.2182	-0.3578	-0.0214	1.3632	0.2344	-0.9213	0.0790
123	0.163	1.148	22.28	30.0	-2.8529	-2.0556	-0.3478	-0.0265	1.3789	0.2573	-1.0162	0.0766
124	0.167	1.198	22.32	30.0	-2.8701	-1.6073	-0.3733	-0.0210	1.4162	0.1930	-0.7422	0.0759
125	0.150	0.951	24.23	30.0	-2.9779	-2.4502	-0.0914	-0.0138	1.2926	0.2889	-1.0905	0.0982
126	0.154	1.001	24.27	30.0	-3.2178	-2.4074	-0.1306	-0.0168	1.4265	0.3127	-1.2562	0.0894
127	0.157	1.051	24.31	30.0	-3.2428	-2.0544	-0.3096	-0.0095	1.6087	0.2417	-0.9431	0.0943
128	0.162	1.099	24.31	30.0	-3.3158	-2.3600	-0.3376	-0.0246	1.6507	0.2545	-0.9837	0.0876

TABLE 1.11

DATA LISTINGS

ROLL ANGLE = 30 DEG.

SER	REYN	MACH	THETA	RANG	NORMAL	PITCH	AXIAL	BASE	DRAG	SIDE F	YAW M	ROLL M
129	0.167	1.148	24.35	30.0	-3.5763	-2.1841	-0.3192	-0.0286	1.6570	0.2856	-1.0390	0.0856
130	0.168	1.198	24.40	30.0	-3.4165	-1.7480	-0.3502	-0.0225	1.7100	0.2552	-0.8764	0.0804
131	0.150	0.948	26.29	30.0	-3.4583	-2.3807	-0.0641	-0.0123	1.5782	0.2542	-1.0635	0.1201
132	0.157	0.997	26.35	30.0	-3.7195	-2.3232	-0.0947	-0.0157	1.7215	0.3030	-1.2734	0.1027
133	0.158	1.048	26.39	30.0	-3.7699	-2.0793	-0.2913	-0.0159	1.9223	0.2597	-1.0293	0.1041
134	0.163	1.099	26.39	30.0	-3.8727	-2.5277	-0.3218	-0.0244	1.9880	0.2414	-0.9853	0.0953
135	0.167	1.149	26.43	30.0	-3.9131	-2.3391	-0.3102	-0.0305	1.9922	0.2731	-1.0742	0.0919
136	0.172	1.200	26.48	30.0	-3.9606	-1.9333	-0.3335	-0.0254	2.0418	0.2350	-0.8592	0.0895
137	0.150	0.949	28.36	30.0	-3.9892	-2.3896	-0.0256	-0.0187	1.9011	0.2412	-1.0263	0.1319
138	0.157	1.002	28.43	30.0	-4.2258	-2.1983	-0.0894	-0.0199	2.0728	0.3431	-1.3152	0.1089
139	0.162	1.051	28.46	30.0	-4.3583	-2.3300	-0.2831	-0.0141	2.3135	0.2781	-1.0426	0.1026
140	0.163	1.100	28.47	30.0	-4.4248	-2.6157	-0.3141	-0.0312	2.3582	0.2716	-1.0513	0.0985
141	0.168	1.150	28.50	30.0	-4.4767	-2.4792	-0.2946	-0.0326	2.3670	0.3015	-1.1401	0.0983
142	0.173	1.200	28.56	30.0	-4.5111	-2.1128	-0.3154	-0.0283	2.4088	0.2293	-0.8521	0.0937

TABLE 1.12

DATA LISTINGS

ROLL ANGLE = 37,5 DEG.

SER	REYN	MACH	THETA	RANG	NORMAL	PITCH	AXIAL	BASE	DRAG	SIDE F	YAW M	ROLL M
2	0.152	0.949	-2.02	37.5	0.1148	0.0821	-0.1647	0.0099	0.1785	0.0192	-0.0364	0.0174
3	0.158	1.022	-2.02	37.5	0.1187	0.1163	-0.1964	0.0056	0.2060	0.0198	-0.0239	0.0176
4	0.162	1.049	-2.02	37.5	0.1206	0.0714	-0.3302	0.0111	0.3452	0.0130	-0.0117	0.0179
5	0.165	1.100	-2.02	37.5	0.1185	0.0685	-0.3496	-0.0064	0.3472	0.0220	-0.0199	0.0178
6	0.172	1.149	-2.02	37.5	0.1282	0.0999	-0.3478	-0.0099	0.3421	0.0268	-0.0965	0.0169
7	0.173	1.201	-2.02	37.5	0.1492	0.1650	-0.3725	-0.0076	0.3699	-0.0067	0.0440	0.0180
8	0.155	0.951	0.01	37.5	-0.0184	-0.0421	-0.1542	0.0062	0.1603	0.0136	-0.0280	0.0163
9	0.158	1.002	0.01	37.5	-0.0257	-0.0639	-0.1981	0.0049	0.2029	0.0148	-0.0235	0.0167
10	0.165	1.050	-0.01	37.5	-0.0307	-0.0870	-0.3311	0.0124	0.3435	0.0099	-0.0136	0.0166
11	0.168	1.099	-0.01	37.5	-0.0324	-0.0883	-0.3620	-0.0054	0.3566	0.0102	-0.0104	0.0173
12	0.173	1.149	-0.01	37.5	-0.0219	-0.0846	-0.3448	-0.0100	0.3347	0.0255	-0.0872	0.0174
13	0.176	1.199	0.01	37.5	-0.0060	-0.0004	-0.3653	-0.0086	0.3567	-0.0026	0.0472	0.0171
14	0.157	0.949	2.00	37.5	-0.1589	-0.1951	-0.1652	0.0075	0.1781	0.0153	-0.0238	0.0171
15	0.163	1.000	2.00	37.5	-0.1744	-0.2490	-0.2017	0.0032	0.2108	0.0083	-0.0145	0.0174
16	0.167	1.052	2.00	37.5	-0.1772	-0.2389	-0.3341	0.0039	0.3440	0.0197	-0.0203	0.0182
17	0.170	1.100	2.00	37.5	-0.1841	-0.2782	-0.3578	-0.0053	0.3587	0.0101	-0.0067	0.0167
18	0.175	1.150	2.00	37.5	-0.1812	-0.2549	-0.3470	-0.0099	0.3432	0.0269	-0.1124	0.0180
19	0.178	1.200	2.00	37.5	-0.1672	-0.1787	-0.3694	-0.0074	0.3677	-0.0023	0.0384	0.0183
20	0.160	0.950	4.01	37.5	-0.2990	-0.3434	-0.1692	0.0064	0.1961	0.0243	-0.0837	0.0188
21	0.163	0.999	4.01	37.5	-0.3281	-0.4325	-0.1950	0.0035	0.2209	0.0191	-0.0556	0.0195
22	0.170	1.051	4.02	37.5	-0.3274	-0.3822	-0.3345	0.0118	0.3683	0.0090	-0.0122	0.0184
23	0.173	1.100	4.01	37.5	-0.3353	-0.4269	-0.3531	-0.0018	0.3739	0.0233	-0.0615	0.0193
24	0.178	1.148	4.02	37.5	-0.3364	-0.4274	-0.3399	-0.0092	0.3534	0.0243	-0.0983	0.0203
25	0.183	1.199	4.02	37.5	-0.3227	-0.3279	-0.3699	-0.0086	0.3830	-0.0011	0.0219	0.0197
26	0.160	0.949	6.02	37.5	-0.4587	-0.5387	-0.1499	0.0060	0.2032	0.0330	-0.1306	0.0232
27	0.167	1.001	6.02	37.5	-0.4901	-0.6120	-0.2017	0.0037	0.2558	0.0233	-0.0872	0.0229
28	0.170	1.048	6.03	37.5	-0.4730	-0.4748	-0.3121	0.0084	0.3683	0.0138	-0.0237	0.0206
29	0.175	1.099	6.03	37.5	-0.4984	-0.5903	-0.3629	-0.0066	0.4066	0.0225	-0.0823	0.0227
30	0.178	1.150	6.03	37.5	-0.4952	-0.5733	-0.3397	-0.0111	0.3788	0.0331	-0.1439	0.0236
33	0.168	1.198	6.03	37.5	-0.4783	-0.4584	-0.3796	-0.0096	0.4183	0.0054	0.0109	0.0219
34	0.150	0.952	8.03	37.5	-0.6202	-0.7240	-0.1523	0.0046	0.2420	0.0469	-0.1566	0.0263
35	0.154	0.999	8.03	37.5	-0.6471	-0.7729	-0.1987	0.0023	0.2895	0.0485	-0.1531	0.0264
36	0.158	1.048	8.04	37.5	-0.6686	-0.7377	-0.3241	0.0097	0.4240	0.0321	-0.0855	0.0242
37	0.163	1.099	8.04	37.5	-0.6655	-0.7415	-0.3600	-0.0053	0.4443	0.0290	-0.1017	0.0251
38	0.167	1.149	8.04	37.5	-0.6689	-0.7434	-0.3441	-0.0110	0.4234	0.0528	-0.2262	0.0238
39	0.172	1.201	8.05	37.5	-0.6568	-0.6123	-0.3984	-0.0100	0.4766	0.0100	-0.0127	0.0249
40	0.150	0.950	10.04	37.5	-0.8027	-0.9297	-0.1513	0.0014	0.2903	0.0695	-0.2063	0.0267
41	0.157	1.001	10.04	37.5	-0.8470	-0.9714	-0.1992	0.0023	0.3462	0.0638	-0.2218	0.0261
42	0.162	1.051	10.05	37.5	-0.8699	-0.9433	-0.3555	0.0102	0.5120	0.0474	-0.1499	0.0257
43	0.163	1.101	10.06	37.5	-0.8649	-0.9399	-0.3719	-0.0007	0.5166	0.0442	-0.1498	0.0263
44	0.168	1.150	10.06	37.5	-0.8658	-0.9357	-0.3578	-0.0121	0.4917	0.0671	-0.2532	0.0262

TABLE 1.12

DATA LISTINGS

ROLL ANGLE = 37,5 DEG.

SER	REYN	MACH	THETA	RANG	NORMAL	PITCH	AXIAL	BASE	DRAG	SIDE F	YAW M	ROLL M
45	0.173	1.201	10.07	37.5	-0.8536	-0.7745	-0.3920	-0.0130	0.5225	0.0271	-0.0644	0.0262
46	0.152	0.949	12.05	37.5	-1.0169	-1.1728	-0.1564	0.0046	0.3609	0.0960	-0.3302	0.0259
47	0.158	1.070	12.07	37.5	-1.0591	-1.1837	-0.1987	0.0046	0.4202	0.0928	-0.3358	0.0258
48	0.162	1.049	12.07	37.5	-1.0859	-1.1689	-0.3470	0.0088	0.5752	0.0724	-0.2469	0.0255
49	0.168	1.102	12.07	37.5	-1.0878	-1.1752	-0.3792	-0.0073	0.5913	0.0778	-0.2575	0.0278
50	0.168	1.148	12.08	37.5	-1.0857	-1.1436	-0.3613	-0.0140	0.5668	0.0983	-0.3864	0.0272
51	0.173	1.198	12.10	37.5	-1.0743	-0.9451	-0.3834	-0.0143	0.5860	0.0488	-0.1687	0.0283
53	0.155	0.951	14.07	37.5	-1.2494	-1.4481	-0.1348	0.0031	0.4376	0.1070	-0.4029	0.0250
54	0.158	0.999	14.08	37.5	-1.2964	-1.4215	-0.1898	0.0019	0.5014	0.1378	-0.4531	0.0220
55	0.162	1.049	14.09	37.5	-1.3249	-1.3793	-0.3403	0.0000	0.6527	0.1057	-0.3514	0.0267
56	0.168	1.099	14.10	37.5	-1.3171	-1.3687	-0.3699	-0.0117	0.6683	0.1089	-0.3934	0.0300
57	0.173	1.150	14.11	37.5	-1.3201	-1.2853	-0.3638	-0.0150	0.6601	0.1251	-0.4886	0.0297
58	0.175	1.200	14.13	37.5	-1.3037	-1.0641	-0.3943	-0.0128	0.6882	0.0883	-0.3047	0.0307
59	0.155	0.951	16.08	37.5	-1.4896	-1.6899	-0.1317	0.0003	0.5397	0.1378	-0.5026	0.0259
60	0.162	1.072	16.11	37.5	-1.5676	-1.6528	-0.1753	-0.0014	0.6001	0.1473	-0.5645	0.0220
61	0.165	1.049	16.12	37.5	-1.5815	-1.5529	-0.3445	0.0080	0.7779	0.1192	-0.4243	0.0259
62	0.168	1.099	16.13	37.5	-1.5623	-1.5077	-0.3751	-0.0096	0.7852	0.1424	-0.5186	0.0329
63	0.173	1.149	16.14	37.5	-1.5667	-1.4161	-0.3608	-0.0169	0.7660	0.1471	-0.5824	0.0306
64	0.176	1.199	16.16	37.5	-1.5674	-1.1470	-0.3917	-0.0152	0.7982	0.1167	-0.4019	0.0353
67	0.147	0.949	18.10	37.5	-1.7469	-1.9367	-0.1212	-0.0015	0.6565	0.1652	-0.5924	0.0333
68	0.152	0.998	18.12	37.5	-1.8527	-1.9417	-0.1548	-0.0038	0.7197	0.1821	-0.6686	0.0268
69	0.155	1.046	18.15	37.5	-1.8448	-1.5937	-0.3220	0.0019	0.8824	0.1500	-0.5239	0.0333
70	0.157	1.049	18.15	37.5	-1.8617	-1.6511	-0.3263	0.0003	0.8902	0.1507	-0.5238	0.0330
71	0.162	1.098	18.16	37.5	-1.8551	-1.6507	-0.3565	-0.0144	0.9031	0.1474	-0.5809	0.0388
72	0.167	1.151	18.17	37.5	-1.8802	-1.4915	-0.3611	-0.0174	0.9130	0.1798	-0.6940	0.0361
73	0.168	1.202	18.21	37.5	-1.9283	-1.2347	-0.3890	-0.0150	0.9578	0.1363	-0.5075	0.0425
74	0.150	0.949	20.13	37.5	-2.0896	-2.1849	-0.1133	-0.0076	0.8184	0.1886	-0.6511	0.0450
75	0.154	0.998	47.06	37.5	-2.2174	-2.0589	-0.1561	-0.0082	0.9032	0.1821	-0.6650	0.0365
76	0.157	1.049	20.19	37.5	-2.2618	-1.8772	-0.3457	-0.0013	1.1038	0.1588	-0.5524	0.0423
77	0.163	1.099	20.20	37.5	-2.2589	-1.7860	-0.3591	-0.0170	1.1013	0.1794	-0.6681	0.0491
78	0.167	1.149	20.23	37.5	-2.2925	-1.6554	-0.3553	-0.0193	1.1080	0.1787	-0.6730	0.0443
79	0.168	1.200	20.27	37.5	-2.3537	-1.3038	-0.3784	-0.0166	1.1549	0.1235	-0.4726	0.0536
80	0.150	0.951	22.17	37.5	-2.4711	-2.2619	-0.1113	-0.0086	1.0279	0.1831	-0.6515	0.0570
81	0.154	0.999	22.23	37.5	-2.6869	-2.1473	-0.1459	-0.0061	1.1456	0.1917	-0.7064	0.0448
82	0.160	1.049	22.25	37.5	-2.7129	-1.9332	-0.3276	-0.0061	1.3250	0.1514	-0.5296	0.0528
83	0.163	1.100	22.26	37.5	-2.7195	-1.9148	-0.3409	-0.0175	1.3298	0.1793	-0.6020	0.0535
84	0.168	1.150	22.29	37.5	-2.7719	-1.7292	-0.3466	-0.0209	1.3532	0.1743	-0.6335	0.0505
85	0.172	1.200	22.34	37.5	-2.8239	-1.3929	-0.3742	-0.0191	1.4020	0.0972	-0.3915	0.0557
86	0.152	0.953	24.24	37.5	-2.9387	-2.1560	-0.0851	-0.0167	1.2691	0.2014	-0.7100	0.0659
87	0.157	1.000	24.30	37.5	-3.1819	-2.0552	-0.1529	-0.0121	1.4376	0.2253	-0.7676	0.0465
88	0.163	1.049	24.32	37.5	-3.2410	-2.0351	-0.3223	-0.0096	1.6199	0.1681	-0.5552	0.0508

TABLE 1.12
DATA LISTINGS

ROLL ANGLE = 37,5 DEG.

SER	REYN	MACH	THETA	RANG	NORMAL	PITCH	AXIAL	BASE	DRAG	SIDE F	YAW M	ROLL M
89	0.165	1.171	24.32	37,5	-3.2343	-2.1183	-0.3298	-0.0258	1.6097	0.1560	-0.5771	0.0563
90	0.168	1.151	24.38	37,5	-3.2954	-1.8302	-0.3153	-0.0271	1.6227	0.1833	-0.6257	0.0494
91	0.173	1.200	24.42	37,5	-3.3653	-1.5254	-0.3638	-0.0225	1.7022	0.1461	-0.4747	0.0562
92	0.155	0.952	26.31	37,5	-3.4057	-2.0798	-0.0606	-0.0162	1.5495	0.2092	-0.7310	0.0746
93	0.158	0.998	26.36	37,5	-3.6666	-2.0482	-0.1130	-0.0137	1.7174	0.2092	-0.7892	0.0584
94	0.163	1.049	26.40	37,5	-3.7586	-2.0998	-0.3228	-0.0168	1.9452	0.1649	-0.5982	0.0575
95	0.168	1.171	26.41	37,5	-3.7953	-2.2527	-0.3239	-0.0318	1.9499	0.1618	-0.5717	0.0574
96	0.172	1.148	26.45	37,5	-3.8409	-1.9989	-0.3122	-0.0301	1.9636	0.1541	-0.5950	0.0545
97	0.176	1.199	26.50	37,5	-3.9018	-1.6813	-0.3382	-0.0248	2.0216	0.1497	-0.4519	0.0516
98	0.155	0.949	28.38	37,5	-3.9046	-1.9935	-0.0367	-0.0171	1.8735	0.1980	-0.6970	0.0809
99	0.162	1.001	28.45	37,5	-4.1665	-1.8432	-0.0930	-0.0161	2.0527	0.2431	-0.8210	0.0624
100	0.165	1.048	28.47	37,5	-4.2903	-2.1334	-0.2940	-0.0154	2.2905	0.1761	-0.6022	0.0566
101	0.168	1.100	28.49	37,5	-4.3375	-2.3287	-0.3133	-0.0307	2.3177	0.1544	-0.5638	0.0584
102	0.173	1.148	28.53	37,5	-4.3896	-2.1209	-0.2811	-0.0337	2.3144	0.2249	-0.7446	0.0563
103	0.176	1.198	28.59	37,5	-4.4539	-1.8855	-0.3197	-0.0275	2.3876	0.1580	-0.4658	0.0537

TABLE 1.13
DATA LISTINGS

ROLL ANGLE = 45 DEG.

SER	REYN	MACH	THETA	RANG	NORMAL	PITCH	AXIAL	BASE	DRAG	SIDE F	YAW M	ROLL M
106	0.144	0.951	-2.02	45.0	0.1162	0.0996	-0.1515	0.0080	0.1635	0.0096	-0.0134	0.0183
107	0.149	0.998	-2.02	45.0	0.1267	0.1184	-0.1882	0.0065	0.1990	0.0151	-0.0167	0.0183
108	0.155	1.051	-2.02	45.0	0.1148	0.0712	-0.3300	0.0133	0.3471	0.0175	-0.0194	0.0182
109	0.158	1.099	-2.02	45.0	0.1262	0.0863	-0.3593	-0.0075	0.3559	0.0173	-0.0342	0.0185
110	0.162	1.149	-2.02	45.0	0.1330	0.1075	-0.3407	-0.0090	0.3362	0.0252	-0.0907	0.0182
111	0.163	1.199	-2.02	45.0	0.1527	0.1758	-0.3627	-0.0081	0.3597	-0.0023	0.0550	0.0174
112	0.147	0.951	0.01	45.0	-0.0180	-0.0327	-0.1451	0.0079	0.1530	0.0180	-0.0271	0.0175
113	0.152	0.999	0.01	45.0	-0.0260	-0.0530	-0.1948	0.0064	0.2012	0.0235	-0.0450	0.0174
114	0.155	1.050	0.01	45.0	-0.0288	-0.0684	-0.3456	0.0122	0.3578	0.0113	-0.0158	0.0173
115	0.160	1.101	0.01	45.0	-0.0192	-0.0617	-0.3614	-0.0062	0.3552	0.0172	-0.0171	0.0178
116	0.163	1.148	-0.01	45.0	-0.0246	-0.0677	-0.3416	-0.0077	0.3339	0.0206	-0.0843	0.0180
117	0.167	1.200	0.01	45.0	-0.0033	0.0032	-0.3700	-0.0066	0.3634	-0.0037	0.0241	0.0171
118	0.147	0.951	2.01	45.0	-0.1564	-0.1802	-0.1699	0.0067	0.1819	0.0147	-0.0275	0.0179
119	0.154	0.998	2.00	45.0	-0.1725	-0.2405	-0.2036	0.0074	0.2168	0.0142	-0.0361	0.0172
120	0.157	1.050	2.01	45.0	-0.1767	-0.2277	-0.3300	0.0118	0.3477	0.0063	-0.0016	0.0179
121	0.160	1.099	2.01	45.0	-0.1840	-0.2711	-0.3470	0.0048	0.3580	0.0129	-0.0291	0.0183
122	0.167	1.151	2.00	45.0	-0.1815	-0.2460	-0.3470	-0.0088	0.3443	0.0186	-0.0846	0.0189
123	0.167	1.199	2.01	45.0	-0.1616	-0.1644	-0.3724	-0.0074	0.3704	-0.0063	0.0596	0.0183
124	0.150	0.949	4.01	45.0	-0.2980	-0.3388	-0.1582	0.0067	0.1853	0.0150	-0.0342	0.0189
125	0.154	0.998	4.00	45.0	-0.3280	-0.4201	-0.1959	0.0046	0.2230	0.0108	-0.0186	0.0193
126	0.157	1.049	4.02	45.0	-0.3145	-0.3271	-0.3165	0.0088	0.3465	0.0108	-0.0085	0.0184
127	0.163	1.101	4.02	45.0	-0.3340	-0.4270	-0.3550	-0.0070	0.3705	0.0132	-0.0320	0.0193
128	0.167	1.150	4.01	45.0	-0.3311	-0.4103	-0.3381	-0.0085	0.3520	0.0151	-0.0833	0.0196
129	0.172	1.200	4.02	45.0	-0.3200	-0.3126	-0.3730	-0.0090	0.3856	-0.0104	0.0460	0.0191
130	0.152	0.952	6.02	45.0	-0.4487	-0.5064	-0.1513	0.0041	0.2017	0.0123	-0.0274	0.0218
131	0.157	1.001	6.02	45.0	-0.4801	-0.5925	-0.1900	0.0029	0.2423	0.0115	-0.0371	0.0215
132	0.160	1.049	6.03	45.0	-0.4836	-0.5192	-0.3232	0.0119	0.3840	0.0035	0.0090	0.0218
133	0.163	1.099	6.03	45.0	-0.4953	-0.5778	-0.3611	-0.0039	0.4072	0.0115	-0.0254	0.0227
134	0.167	1.148	6.03	45.0	-0.4950	-0.5544	-0.3323	-0.0093	0.3732	0.0171	-0.0798	0.0234
135	0.172	1.199	6.04	45.0	-0.4784	-0.4561	-0.3742	-0.0095	0.4130	-0.0148	0.0601	0.0224
138	0.145	0.950	8.03	45.0	-0.6091	-0.6729	-0.1552	0.0062	0.2449	0.0228	-0.0338	0.0247
139	0.149	1.001	8.03	45.0	-0.6473	-0.7325	-0.2027	0.0020	0.2932	0.0049	0.0063	0.0256
140	0.152	1.050	8.04	45.0	-0.6609	-0.7092	-0.3386	0.0104	0.4380	0.0005	0.0449	0.0270
141	0.157	1.099	8.05	45.0	-0.6610	-0.7307	-0.3598	-0.0013	0.4475	-0.0057	0.0318	0.0267
142	0.158	1.149	8.04	45.0	-0.6631	-0.7256	-0.3403	-0.0109	0.4190	0.0157	-0.0861	0.0263
143	0.165	1.198	8.05	45.0	-0.6476	-0.5583	-0.3847	-0.0102	0.4616	-0.0151	0.0815	0.0270
144	0.147	0.952	10.04	45.0	-0.7998	-0.8928	-0.1443	0.0007	0.2823	0.0101	-0.0064	0.0275
145	0.149	0.999	10.05	45.0	-0.8340	-0.9546	-0.1908	0.0003	0.3336	0.0049	0.0004	0.0290
146	0.155	1.052	10.05	45.0	-0.8523	-0.8925	-0.3351	0.0016	0.4803	0.0046	0.0293	0.0289
147	0.158	1.101	10.05	45.0	-0.8545	-0.9143	-0.3739	-0.0047	0.5127	0.0001	0.0272	0.0295
148	0.163	1.151	10.06	45.0	-0.8599	-0.9130	-0.3539	-0.0140	0.4849	0.0241	-0.0827	0.0285

TABLE 1.13
DATA LISTINGS
ROLL ANGLE = 45 DEG.

SER	REYN	MACH	THETA	RANG	NORMAL	PITCH	AXIAL	BASE	DRAG	SIDE F	YAW M	ROLL M
149	0.165	1.198	10.07	45.0	-0.8422	-0.7426	-0.3892	-0.0133	0.5174	-0.0152	0.2888	0.0282
150	0.147	0.951	12.05	45.0	-1.0076	-1.1297	-0.1364	0.0035	0.3474	0.0209	-0.0397	0.0282
151	0.152	0.999	12.07	45.0	-1.0481	-1.1498	-0.1934	0.0006	0.4088	0.0086	0.0208	0.0273
152	0.155	1.050	12.07	45.0	-1.0778	-1.1308	-0.3429	0.0086	0.5692	0.0055	0.0160	0.0279
153	0.160	1.131	12.08	45.0	-1.0715	-1.1342	-0.3808	-0.0083	0.5885	0.0045	0.0243	0.0308
154	0.163	1.149	12.08	45.0	-1.0769	-1.1089	-0.3577	-0.0130	0.5624	0.0319	-0.1144	0.0283
155	0.167	1.198	12.09	45.0	-1.0665	-0.9136	-0.3887	-0.0137	0.5902	-0.0066	0.0755	0.0274
158	0.145	0.950	14.07	45.0	-1.2294	-1.3751	-0.1315	0.0062	0.4325	0.0339	-0.1005	0.0191
159	0.149	1.022	14.08	45.0	-1.2666	-1.3105	-0.1951	0.0020	0.4994	0.0219	-0.0381	0.0198
160	0.152	1.050	14.09	45.0	-1.3126	-1.3525	-0.3355	0.0099	0.6545	0.0228	-0.0260	0.0193
161	0.157	1.099	14.09	45.0	-1.3025	-1.3281	-0.3658	0.0009	0.6724	0.0199	-0.0106	0.0241
162	0.158	1.152	14.10	45.0	-1.3027	-1.2538	-0.3578	-0.0139	0.6509	0.0366	-0.1319	0.0239
163	0.162	1.199	14.12	45.0	-1.2810	-1.0140	-0.3898	-0.0120	0.6789	0.0024	0.0758	0.0216
164	0.145	0.949	16.08	45.0	-1.4659	-1.6261	-0.1207	-0.0015	0.5207	0.0527	-0.1354	0.0100
165	0.149	0.998	16.10	45.0	-1.5300	-1.5937	-0.1653	-0.0004	0.5828	0.0462	-0.1030	0.0096
166	0.152	1.048	16.12	45.0	-1.5454	-1.4277	-0.3233	0.0029	0.7424	0.0566	-0.1141	0.0070
167	0.158	1.100	16.12	45.0	-1.5517	-1.4612	-0.3642	-0.0113	0.7699	0.0390	-0.0874	0.0192
168	0.158	1.148	16.14	45.0	-1.5550	-1.3611	-0.3535	-0.0163	0.7562	0.0524	-0.1818	0.0174
169	0.165	1.198	16.16	45.0	-1.5597	-1.0947	-0.3942	-0.0148	0.7986	0.0134	-0.0013	0.0214
170	0.145	0.950	18.10	45.0	-1.7408	-1.8864	-0.1378	-0.0055	0.6668	0.0617	-0.1704	0.0120
171	0.152	1.021	18.13	45.0	-1.8277	-1.7832	-0.1755	-0.0007	0.7349	0.0753	-0.2229	0.0055
172	0.155	1.049	18.15	45.0	-1.8544	-1.6142	-0.3319	0.0022	0.8953	0.0674	-0.1877	0.0062
173	0.158	1.098	18.16	45.0	-1.8521	-1.6008	-0.3622	-0.0143	0.9072	0.0599	-0.1589	0.0220
174	0.162	1.147	18.18	45.0	-1.8774	-1.4746	-0.3580	-0.0200	0.9068	0.0615	-0.2058	0.0190
175	0.167	1.199	18.21	45.0	-1.9077	-1.1584	-0.3891	-0.0155	0.9511	0.0308	-0.0655	0.0217
176	0.147	0.952	20.14	45.0	-2.0736	-2.0777	-0.1127	-0.0065	0.8137	0.0675	-0.1850	0.0133
177	0.152	1.021	20.17	45.0	-2.2053	-1.9105	-0.1636	-0.0065	0.9081	0.0941	-0.2572	0.0047
178	0.155	1.053	20.19	45.0	-2.2711	-1.9073	-0.3629	-0.0007	1.1240	0.0739	-0.1707	0.0104
179	0.160	1.101	20.20	45.0	-2.2384	-1.7193	-0.3652	-0.0209	1.0965	0.0672	-0.1802	0.0258
180	0.163	1.151	20.23	45.0	-2.2845	-1.5613	-0.3455	-0.0230	1.0929	0.0684	-0.2482	0.0234
181	0.167	1.200	20.27	45.0	-2.5369	-1.2381	-0.3777	-0.0168	1.1485	0.0453	-0.0916	0.0243
184	0.147	0.949	22.18	45.0	-2.4513	-2.1317	-0.0957	-0.0057	1.0089	0.0752	-0.2135	0.0130
185	0.154	1.020	22.22	45.0	-2.6590	-2.0786	-0.1419	-0.0067	1.1310	0.0974	-0.2126	0.0053
186	0.160	1.049	22.26	45.0	-2.7005	-1.9086	-0.3197	-0.0143	1.3055	0.1258	-0.3627	0.0072
187	0.163	1.099	22.26	45.0	-2.6760	-1.9028	-0.3476	-0.0167	1.3202	0.0776	-0.1967	0.0262
188	0.167	1.150	22.30	45.0	-2.7431	-1.6614	-0.3467	-0.0249	1.3387	0.0810	-0.2429	0.0242
189	0.172	1.200	22.35	45.0	-2.7922	-1.3132	-0.3731	-0.0204	1.3879	0.0325	-0.0677	0.0265
190	0.152	0.950	24.25	45.0	-2.9205	-2.0436	-0.0705	-0.0113	1.2536	0.0587	-0.1910	0.0133
191	0.157	0.999	24.29	45.0	-3.1765	-2.0890	-0.1322	-0.0116	1.4171	0.0834	-0.2040	0.0050
192	0.160	1.052	24.33	45.0	-3.2264	-2.0150	-0.3165	-0.0072	1.6110	0.1013	-0.2946	0.0055
193	0.165	1.121	24.34	45.0	-3.2186	-2.0102	-0.3402	-0.0249	1.6140	0.0785	-0.2169	0.0227

TABLE 1.13
DATA LISTINGS

ROLL ANGLE = 45 DEG.

SER	REYN	MACH	THETA	RANG	NORMAL	PITCH	AXIAL	BASE	DRAG	SIDE F	YAW M	ROLL M
194	0.168	1.148	24.37	45.0	-3.2769	-1.7917	-0.3247	-0.0282	1.6228	0.0581	-0.2007	0.0229
195	0.172	1.198	24.42	45.0	-3.3267	-1.4655	-0.3579	-0.0228	1.6808	0.0548	-0.1044	0.0210
196	0.152	0.949	26.32	45.0	-3.3566	-1.8634	-0.0637	-0.0129	1.5339	0.0511	-0.1367	0.0122
197	0.157	1.001	26.38	45.0	-3.6634	-1.8940	-0.1255	-0.0092	1.7321	0.0790	-0.1701	0.0046
198	0.160	1.048	26.41	45.0	-3.7110	-1.8630	-0.2951	-0.0128	1.9035	0.0884	-0.2135	0.0050
199	0.165	1.099	26.42	45.0	-3.7834	-2.1223	-0.3127	-0.0206	1.9453	0.0742	-0.2066	0.0167
200	0.168	1.148	26.46	45.0	-3.8307	-1.9078	-0.3062	-0.0286	1.9555	0.0860	-0.2140	0.0161
201	0.173	1.199	26.51	45.0	-3.8898	-1.5961	-0.3358	-0.0243	2.0152	0.0860	-0.1517	0.0186
202	0.152	0.950	28.39	45.0	-3.8410	-1.7773	-0.0244	-0.0142	1.8355	0.0791	-0.1860	0.0191
203	0.158	1.071	28.46	45.0	-4.1559	-1.7617	-0.1023	-0.0130	2.0591	0.1128	-0.2128	0.0054
204	0.162	1.052	28.47	45.0	-4.2822	-2.0868	-0.3052	-0.0121	2.2999	0.1243	-0.2619	0.0048
205	0.165	1.102	28.49	45.0	-4.3131	-2.2400	-0.2980	-0.0277	2.2956	0.1085	-0.2642	0.0140
206	0.172	1.149	28.54	45.0	-4.3687	-2.0341	-0.2934	-0.0337	2.3157	0.1145	-0.2893	0.0136
207	0.173	1.221	28.59	45.0	-4.4372	-1.8065	-0.3105	-0.0284	2.3713	0.0733	-0.1181	0.0128

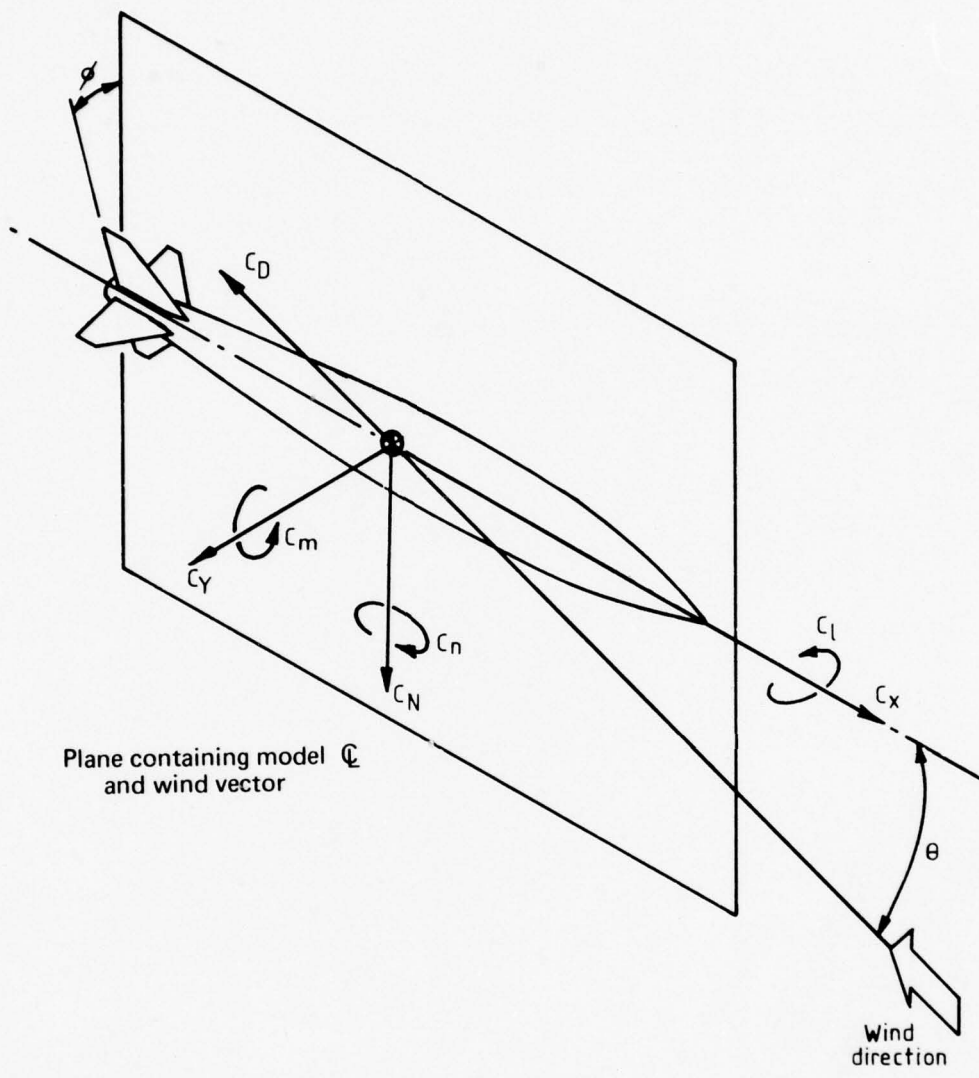
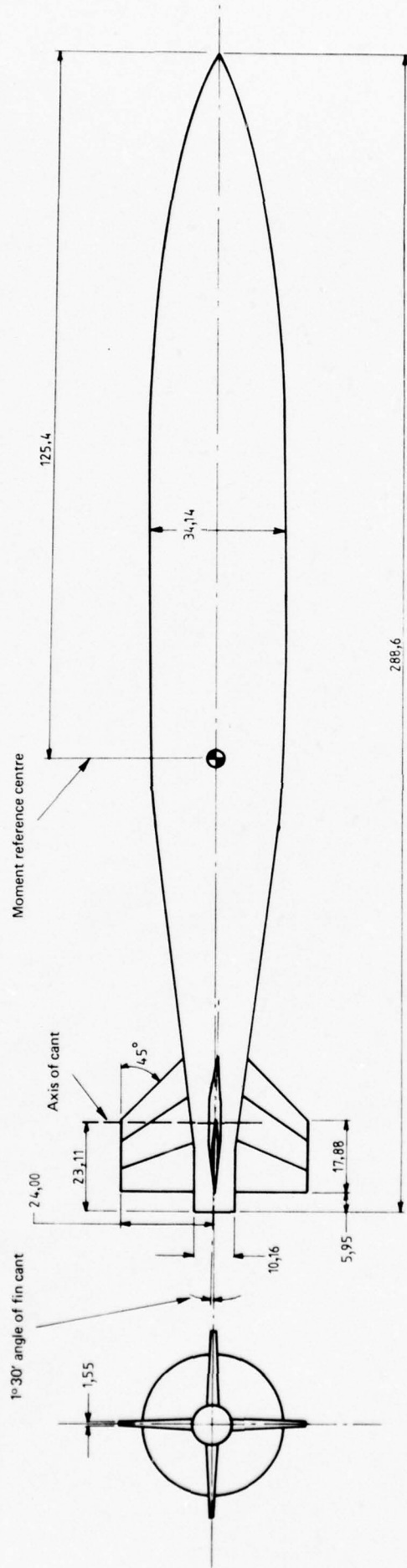

FIG. 1 FORCE AND MOMENT AXES SYSTEM



All dimensions in millimetres

FIG. 2 1/8 SCALE MODEL MK 82 BOMB

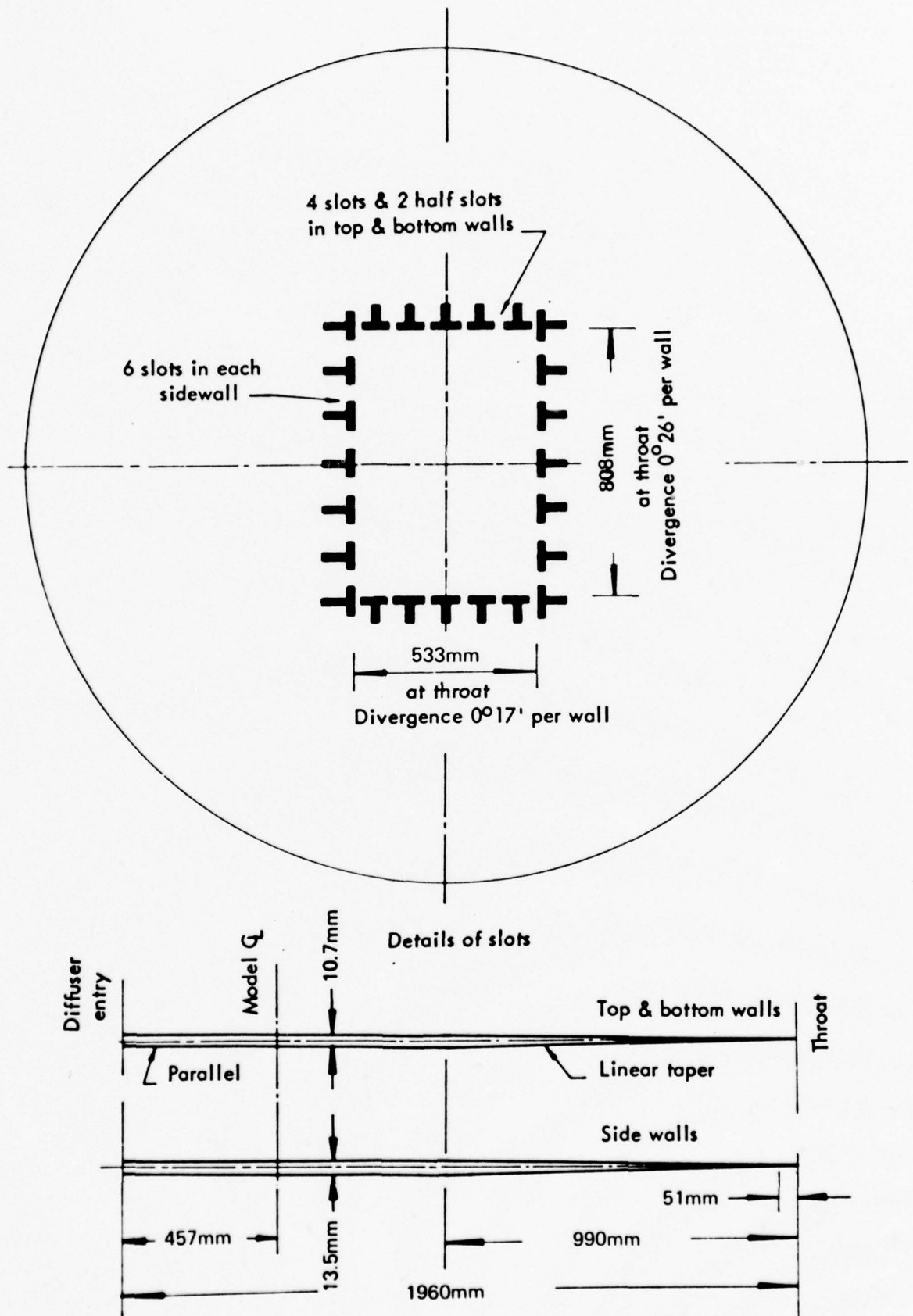

FIG. 3 DETAILS OF SLOTTED TEST SECTION

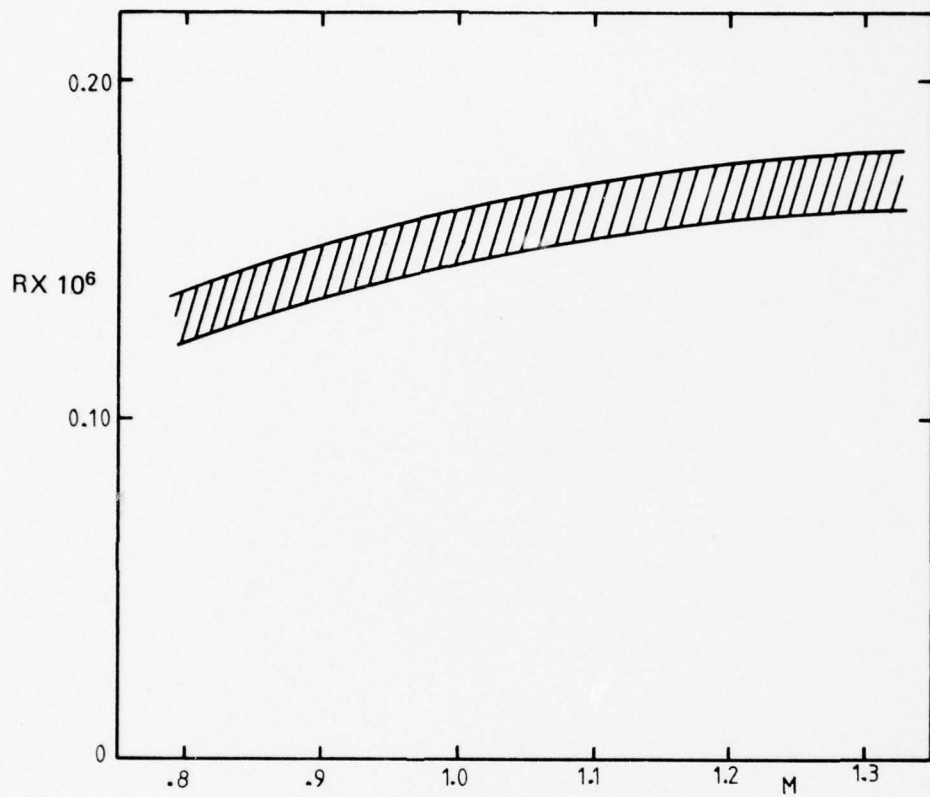
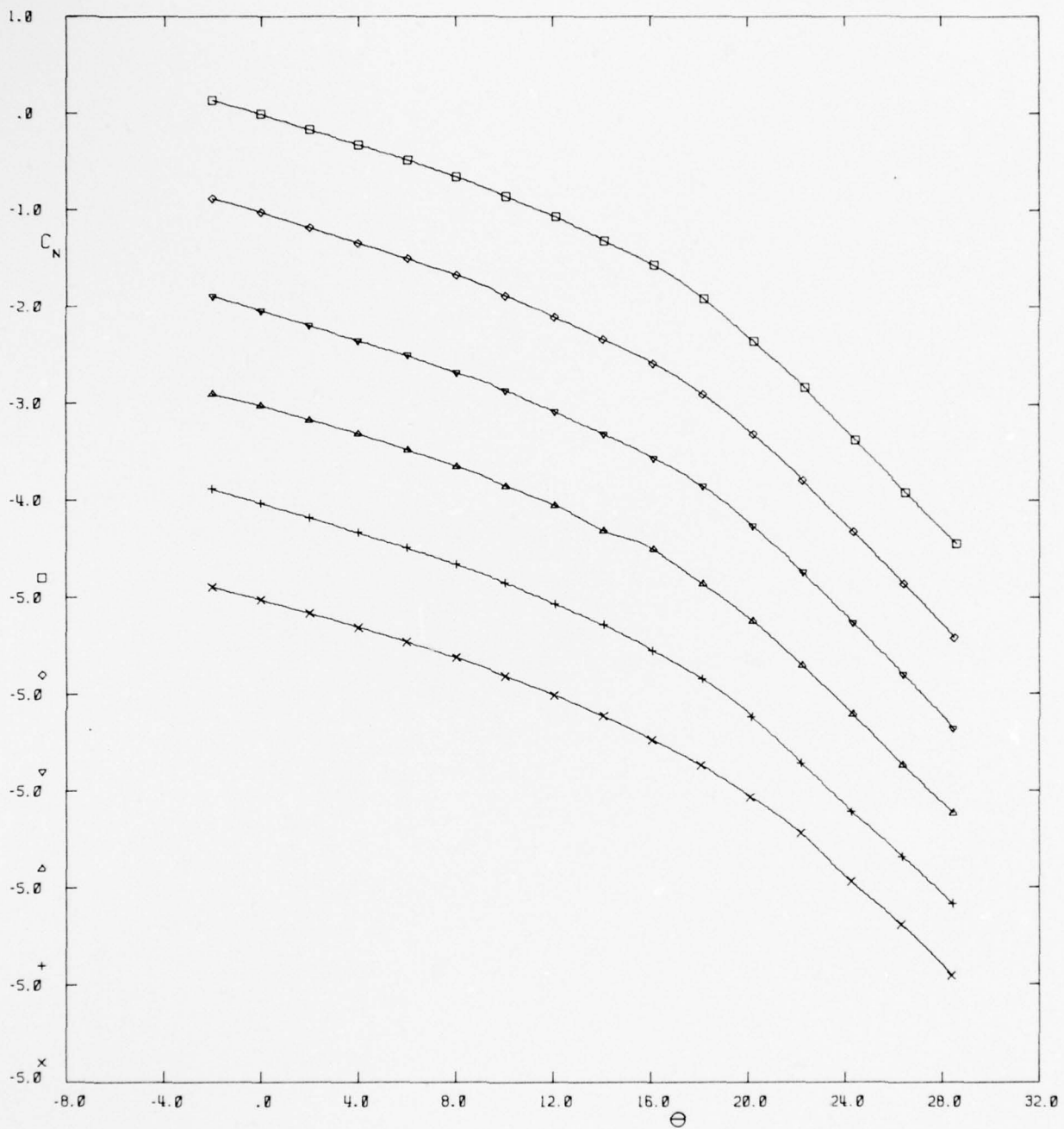
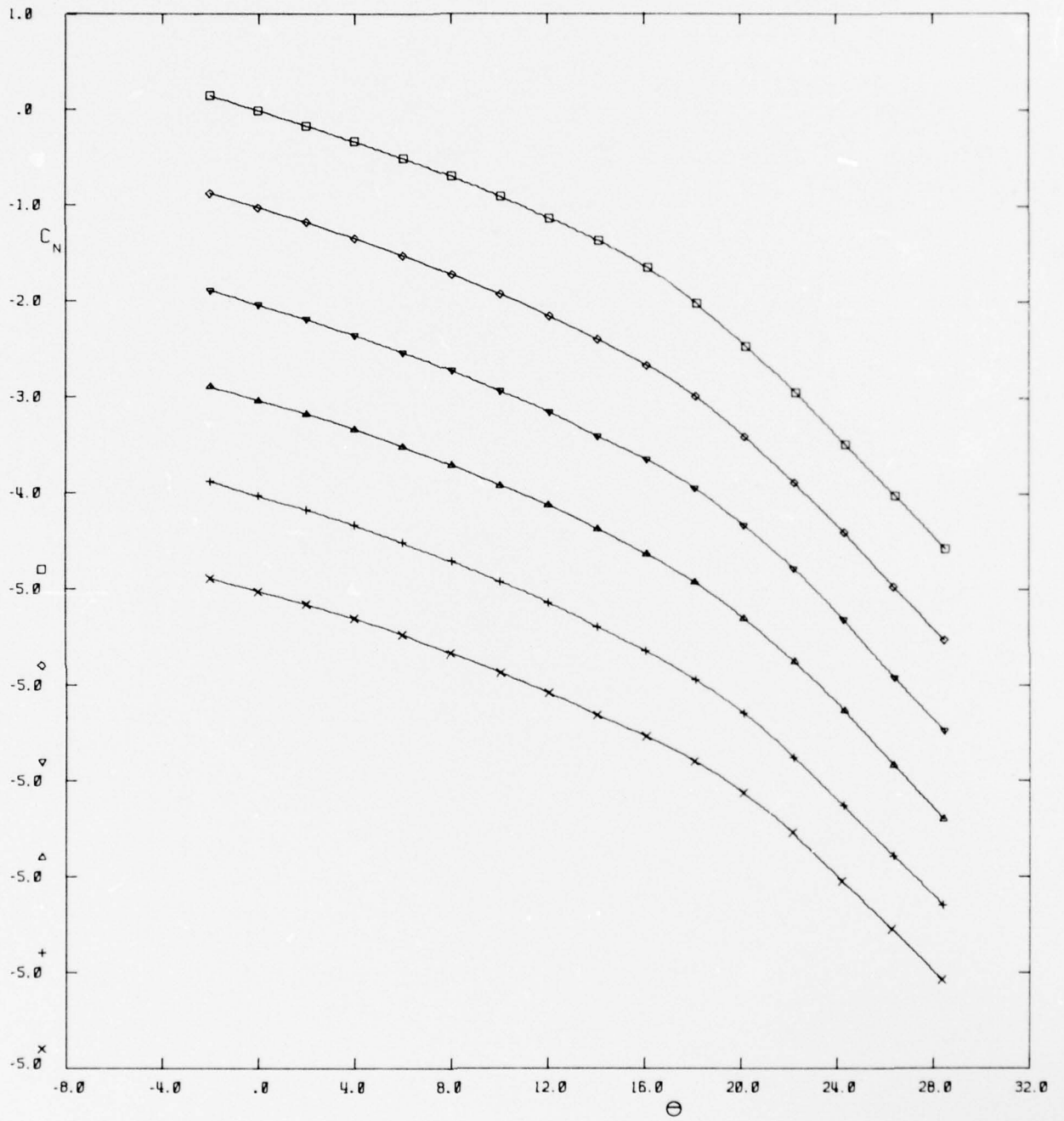

FIG. 4 VARIATION OF TEST REYNOLDS NUMBER WITH MACH NUMBER



REY = .150 * 10⁵

FIG. 5a VARIATION OF NORMAL FORCE COEFFICIENT WITH THETA
ROLL ANGLE = -45 DEG.



SYMBOL	M
x	.95
+	1.00
Δ	1.05
▽	1.10
◇	1.15
□	1.20

REY = .152 * 10⁵

FIG. 5b VARIATION OF NORMAL FORCE COEFFICIENT WITH THETA
ROLL ANGLE = -22.5 DEG.

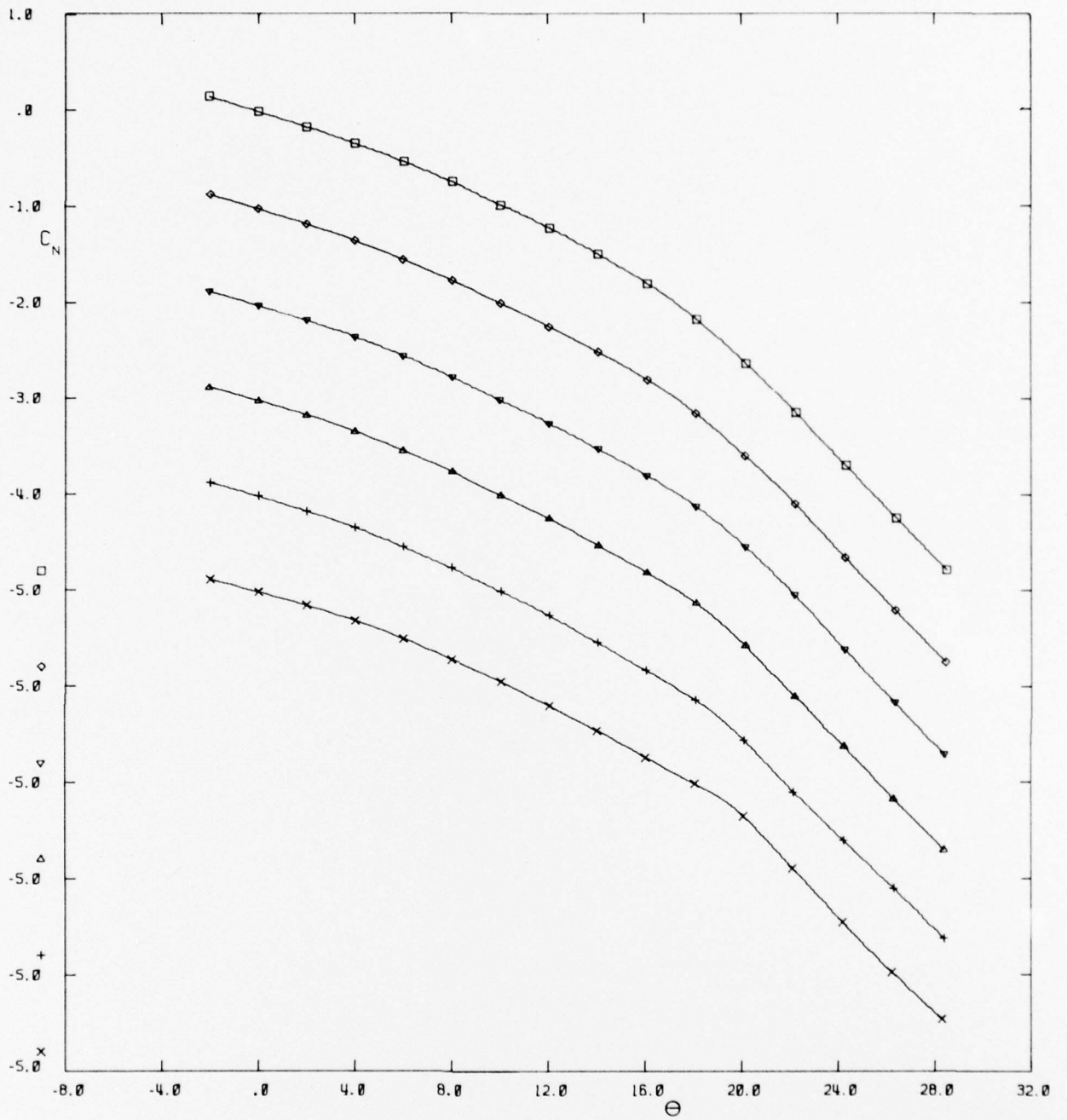

SYMBOL	M
x	.95
+	1.00
△	1.05
▽	1.10
◇	1.15
□	1.20

REY = .150 * 10⁶

FIG. 5c VARIATION OF NORMAL FORCE COEFFICIENT WITH THETA
ROLL ANGLE = 0 DEG.

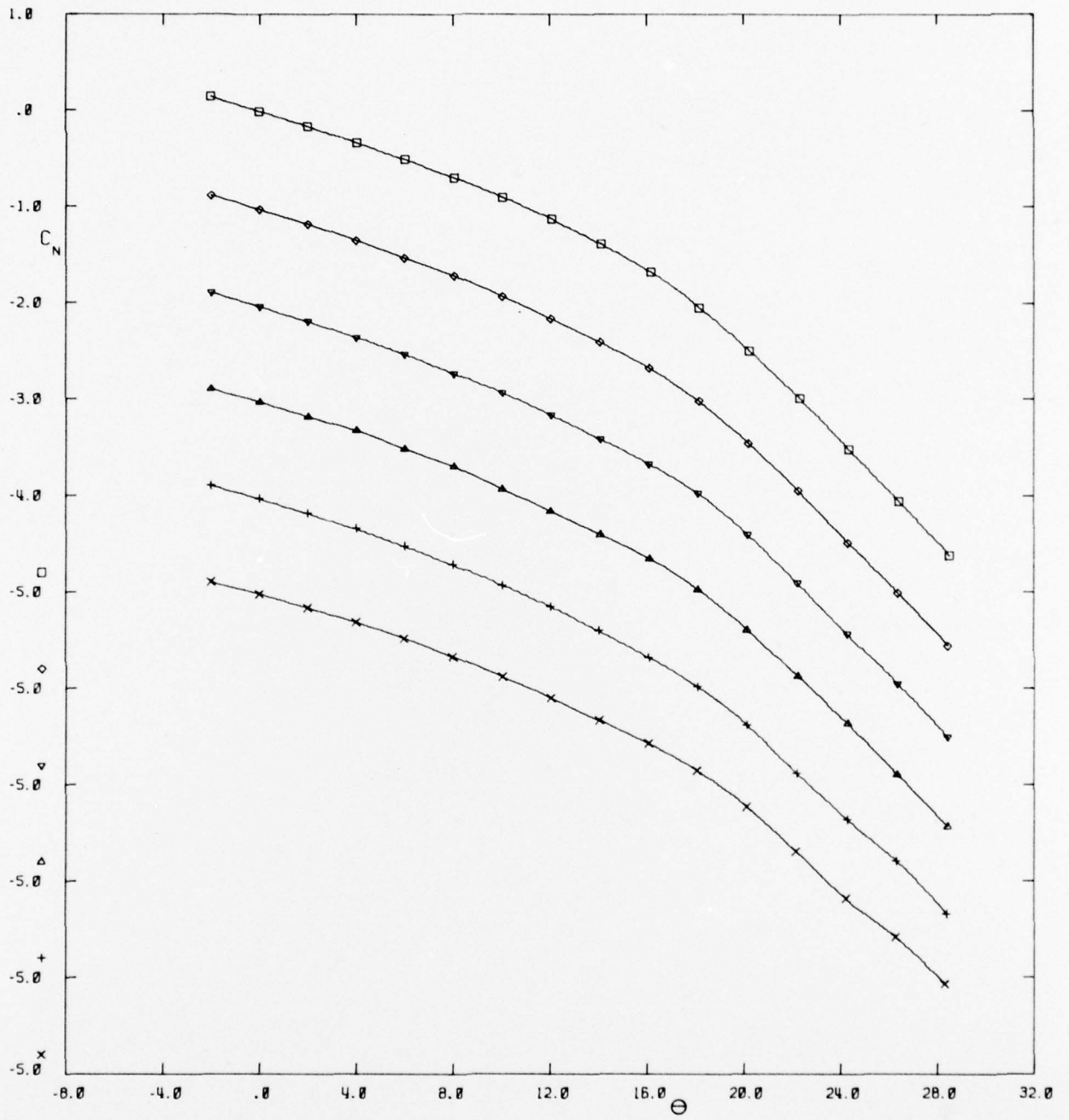

SYMBOL	M
x	.95
+	1.00
△	1.05
▽	1.10
◇	1.15
□	1.20

FIG. 5d VARIATION OF NORMAL FORCE COEFFICIENT WITH THETA
ROLL ANGLE = 22.5 DEG.

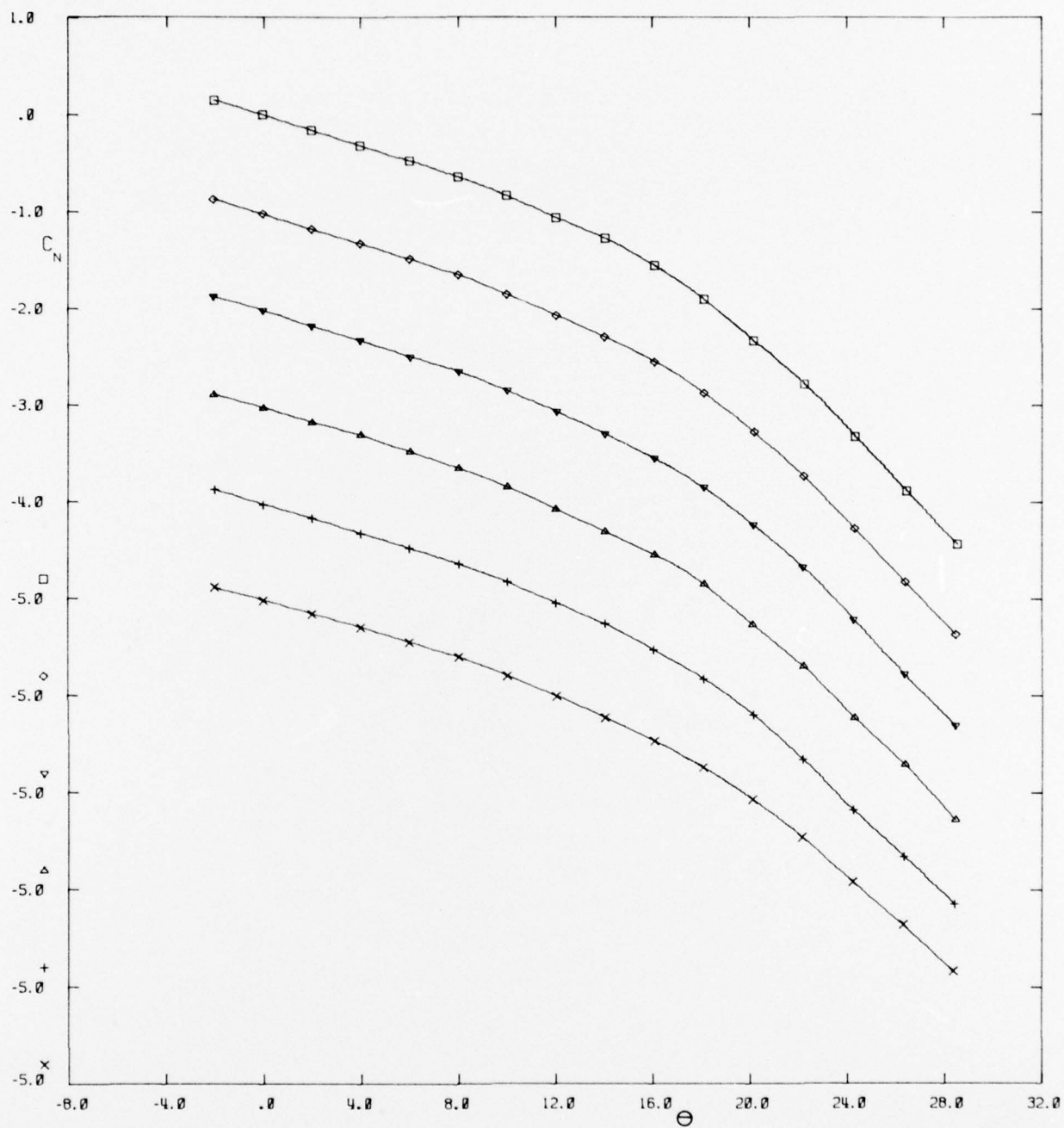

SYMBOL	M
x	.95
+	1.00
Δ	1.05
▽	1.10
◇	1.15
□	1.20

REY = .144 * 10⁵

FIG. 5e VARIATION OF NORMAL FORCE COEFFICIENT WITH THETA
ROLL ANGLE = 45 DEG.

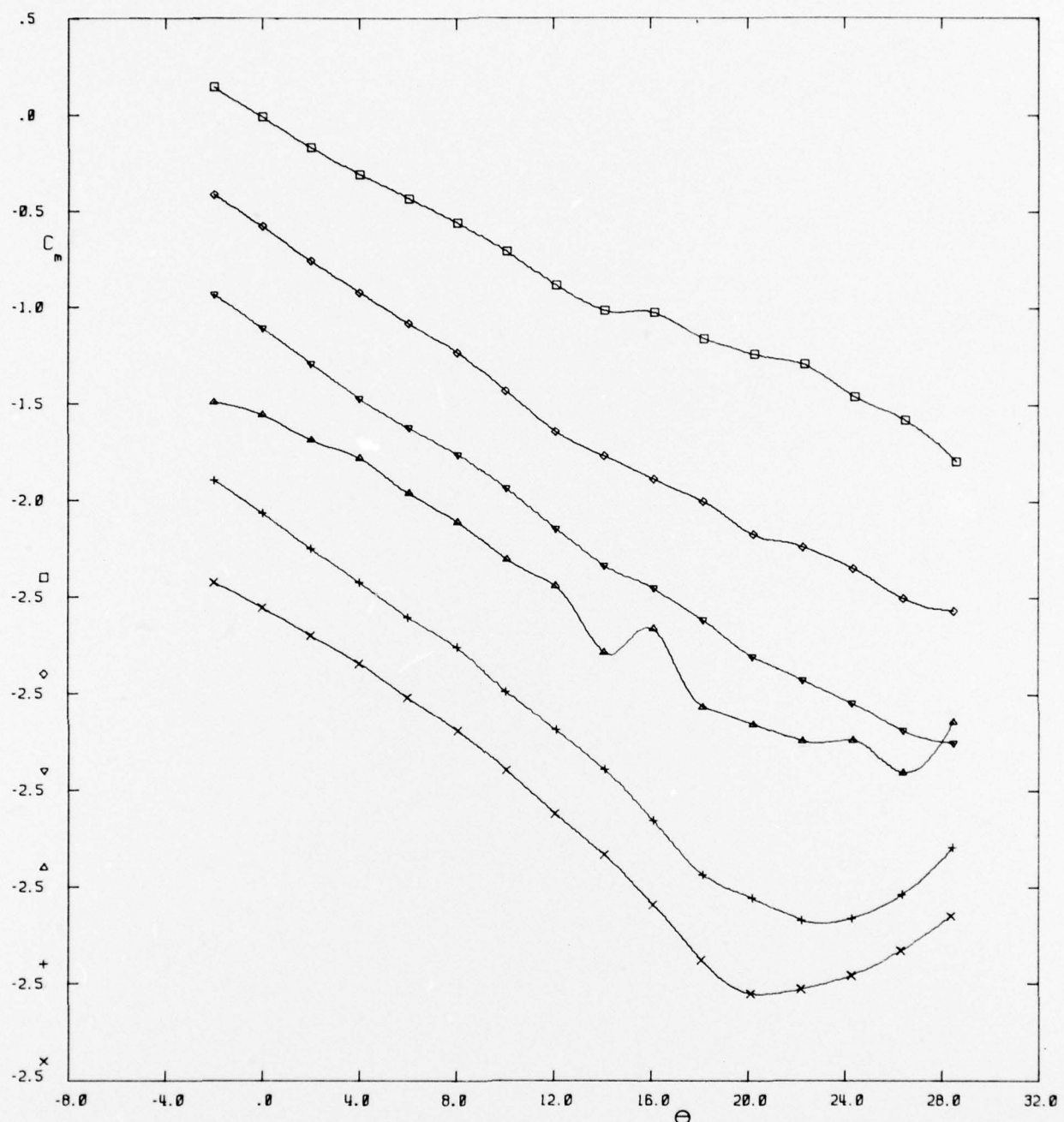

SYMBOL	M
x	.95
+	1.00
Δ	1.05
∇	1.10
\diamond	1.15
\square	1.20

REY = $.150 * 10^6$

FIG. 6a VARIATION OF PITCHING MOMENT COEFFICIENT WITH THETA
ROLL ANGLE = -45° DEG.

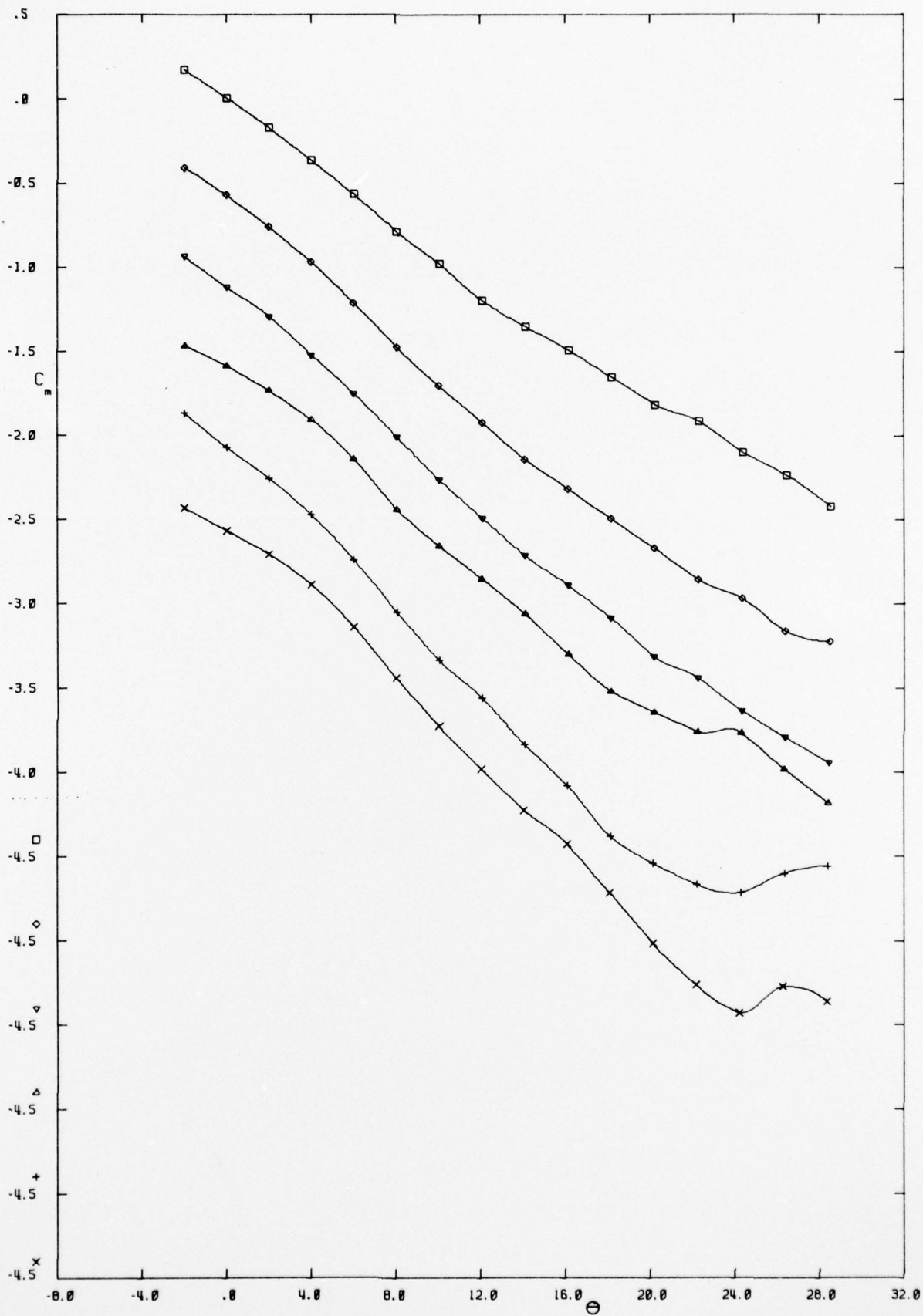

SYMBOL	M
x	.95
+	1.00
Δ	1.05
▽	1.10
◇	1.15
□	1.20

REY = .152 * 10⁶

FIG. 6b VARIATION OF PITCHING MOMENT COEFFICIENT WITH THETA
ROLL ANGLE = -22.5 DEG.

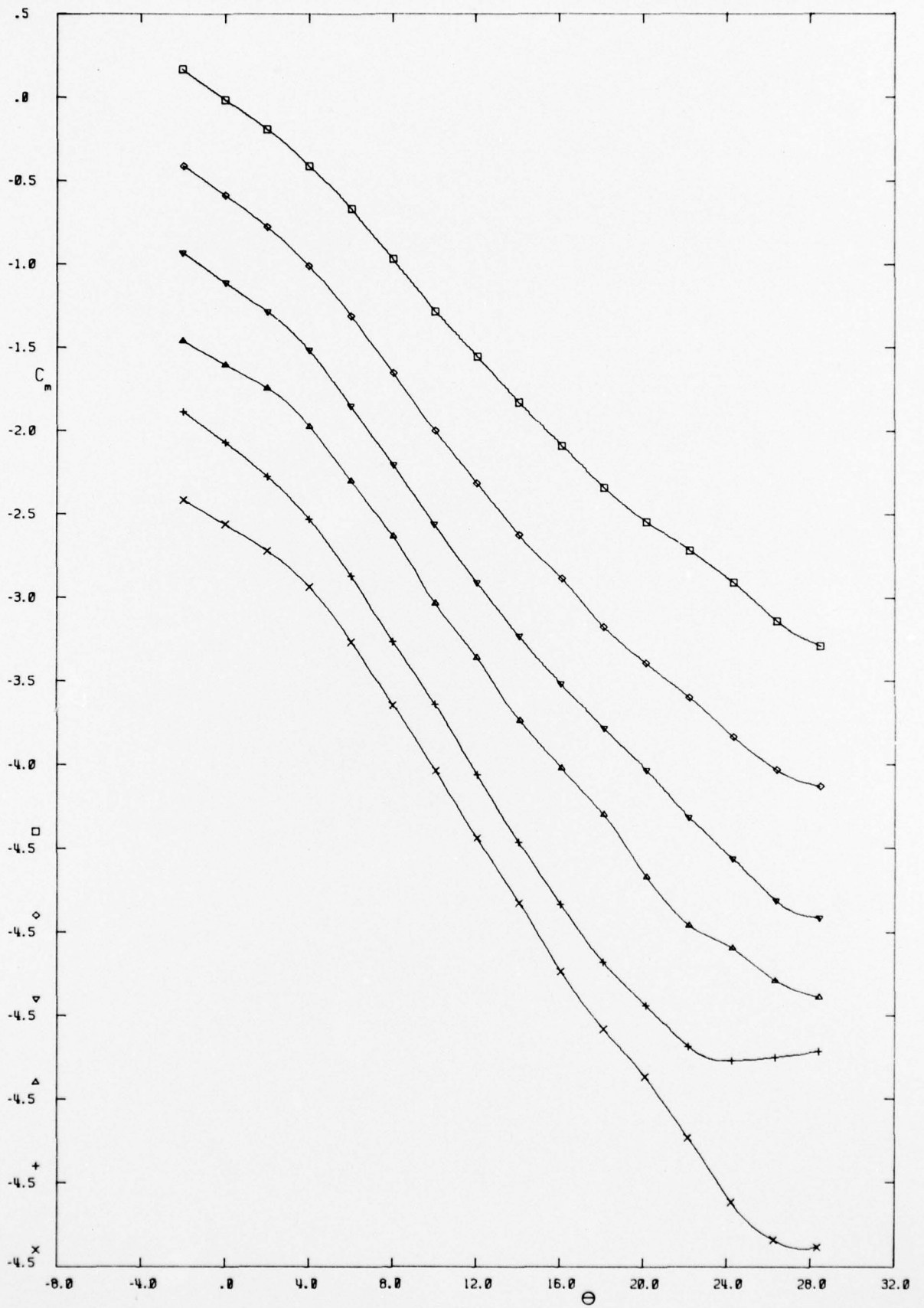

SYMBOL	M
x	.95
+	1.00
Δ	1.05
▽	1.10
◇	1.15
□	1.20

REY = .150 * 10⁵

FIG. 6c VARIATION OF PITCHING MOMENT COEFFICIENT WITH THETA
ROLL ANGLE = 0 DEG.

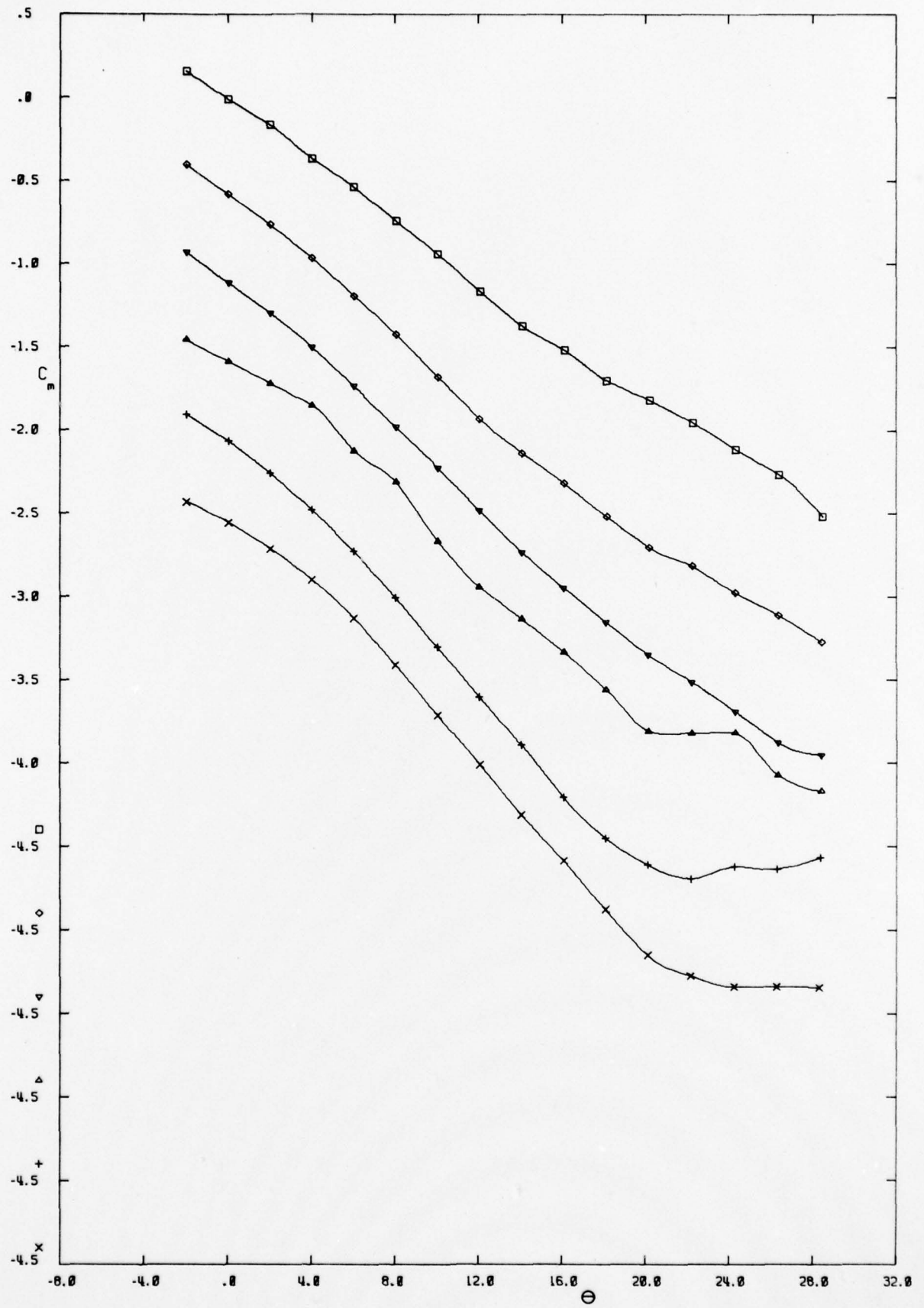

SYMBOL	M
x	.95
+	1.00
△	1.05
▽	1.10
◇	1.15
□	1.20

REY = .139 * 10⁶

FIG. 6d VARIATION OF PITCHING MOMENT COEFFICIENT WITH THETA
ROLL ANGLE = 22.5 DEG.

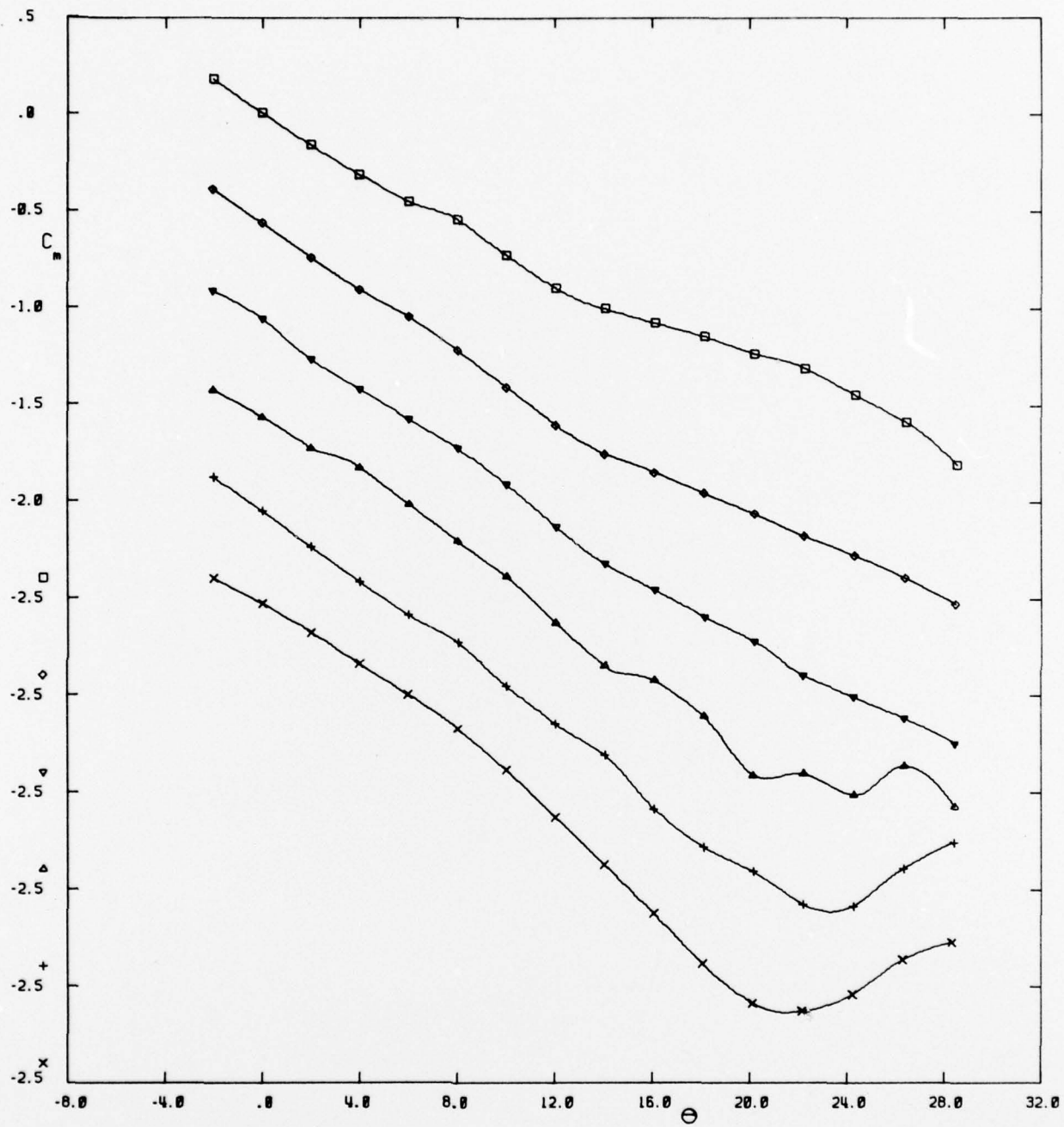

SYMBOL	M
x	.95
+	1.00
▲	1.05
▼	1.10
◇	1.15
□	1.20

REY = .144 * 10⁶

FIG. 6e VARIATION OF PITCHING MOMENT COEFFICIENT WITH THETA
ROLL ANGLE = 45 DEG.

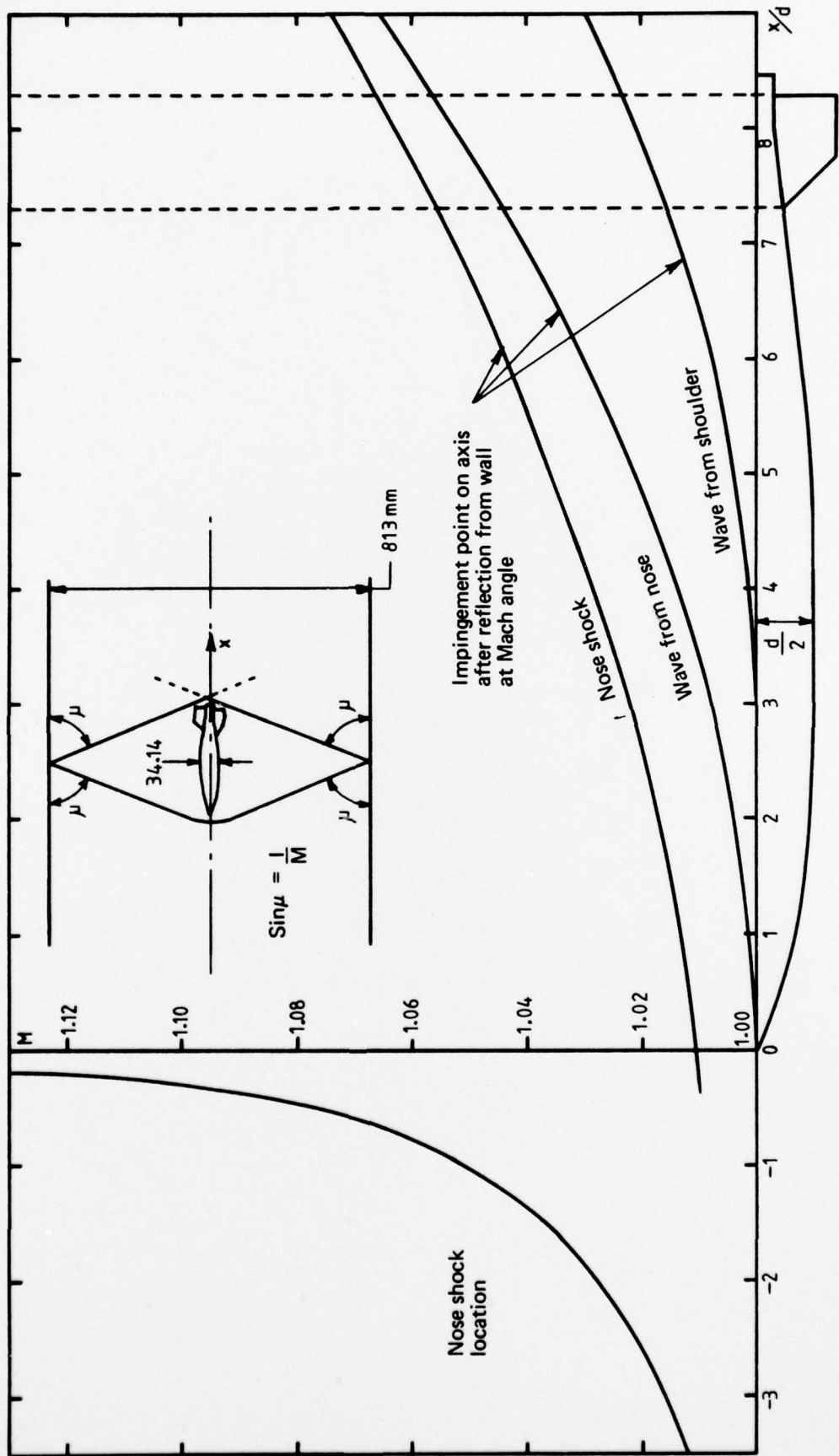

FIG. 7 MACH NUMBER RANGE OF WALL-REFLECTED WAVE INTERFERENCE

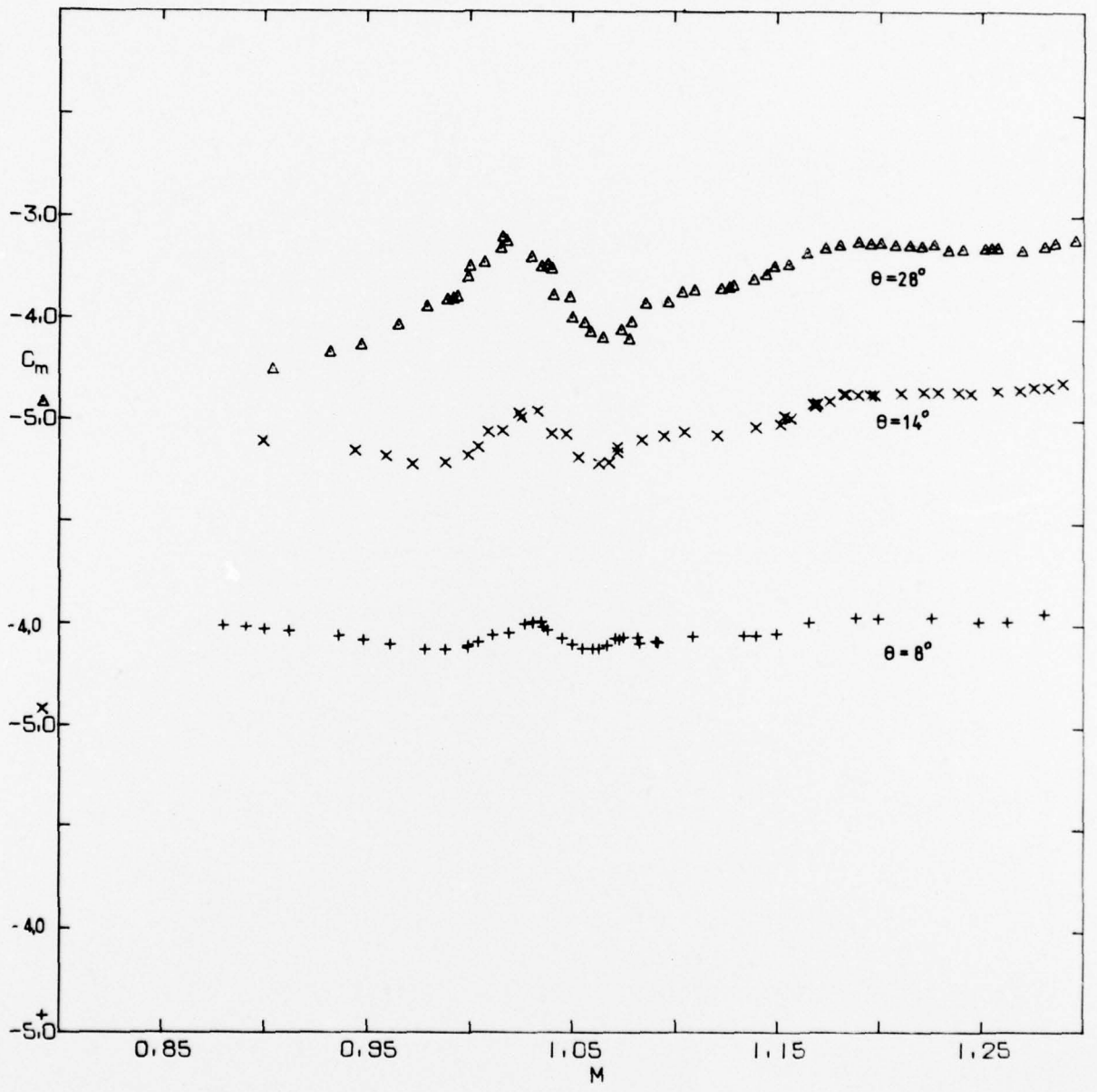

FIG. 8 VARIATION OF PITCHING MOMENT COEFFICIENT WITH MACH NUMBER
ROLL ANGLE = 0 DEG.

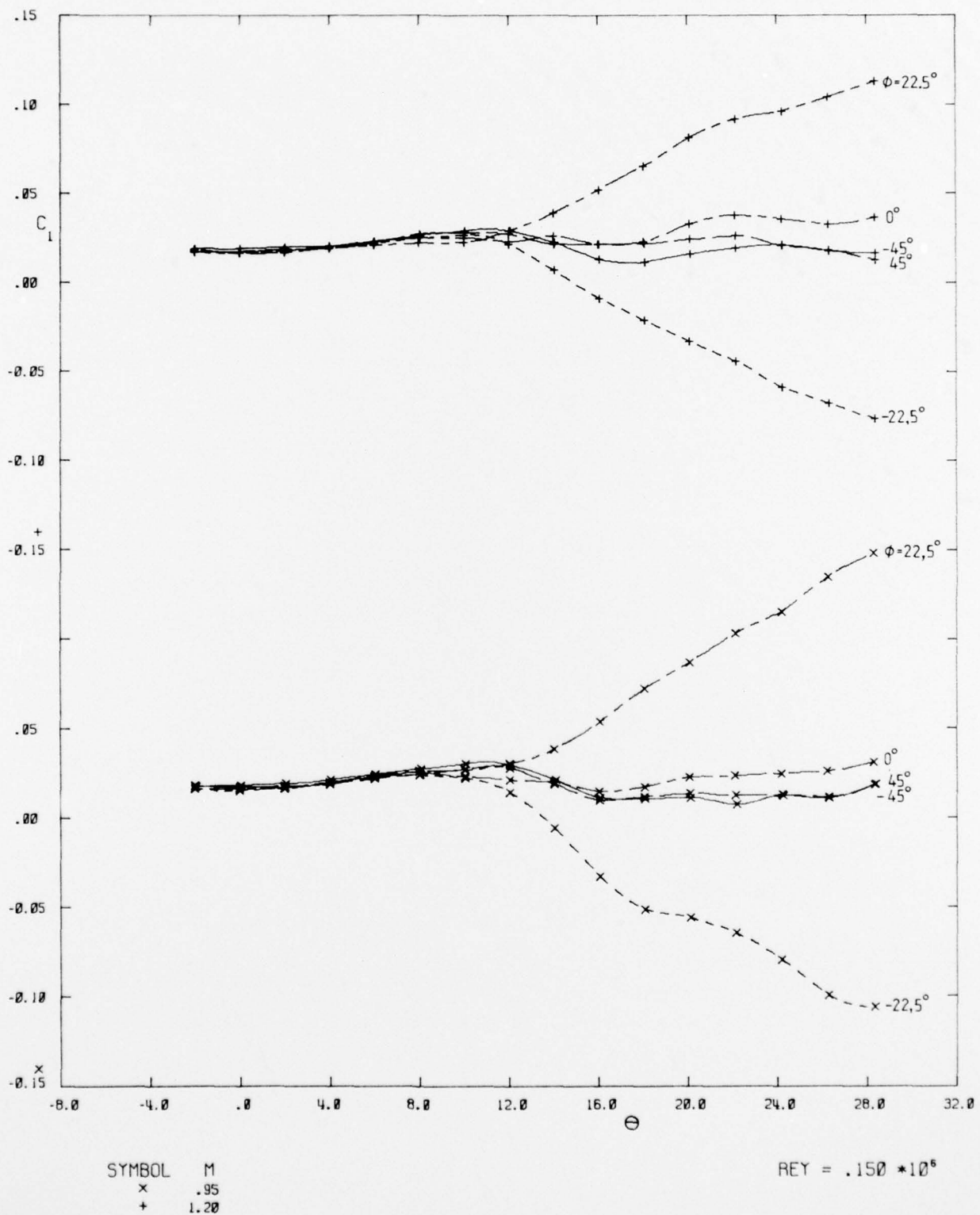
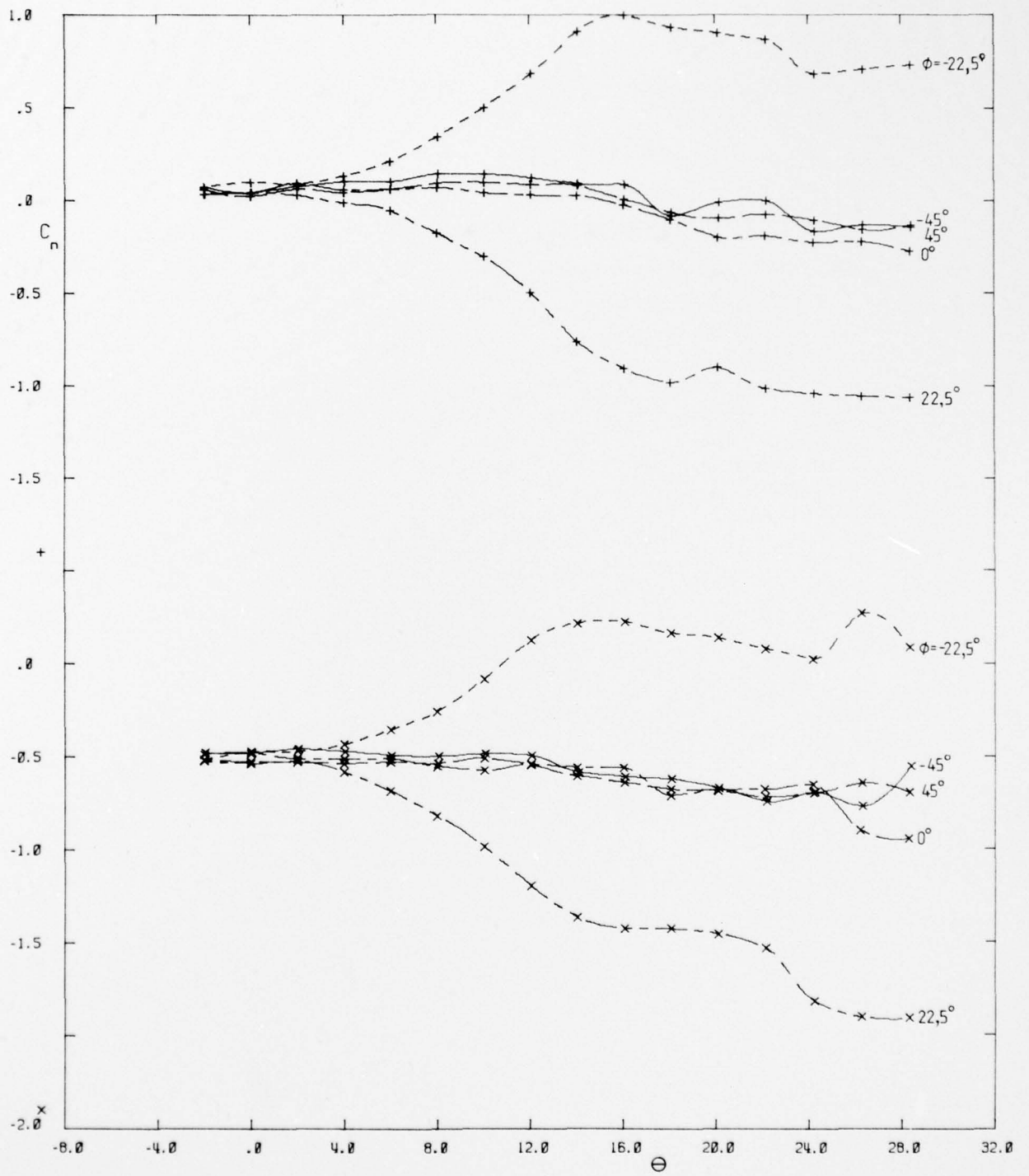

FIG. 9 VARIATION OF ROLLING MOMENT COEFFICIENT WITH THETA
EFFECT OF ROLL ANGLE



SYMBOL M
 x .95
 + 1.20

REY = .150 * 10⁶

FIG. 10 VARIATION OF YAWING MOMENT COEFFICIENT WITH THETA
 EFFECT OF ROLL ANGLE

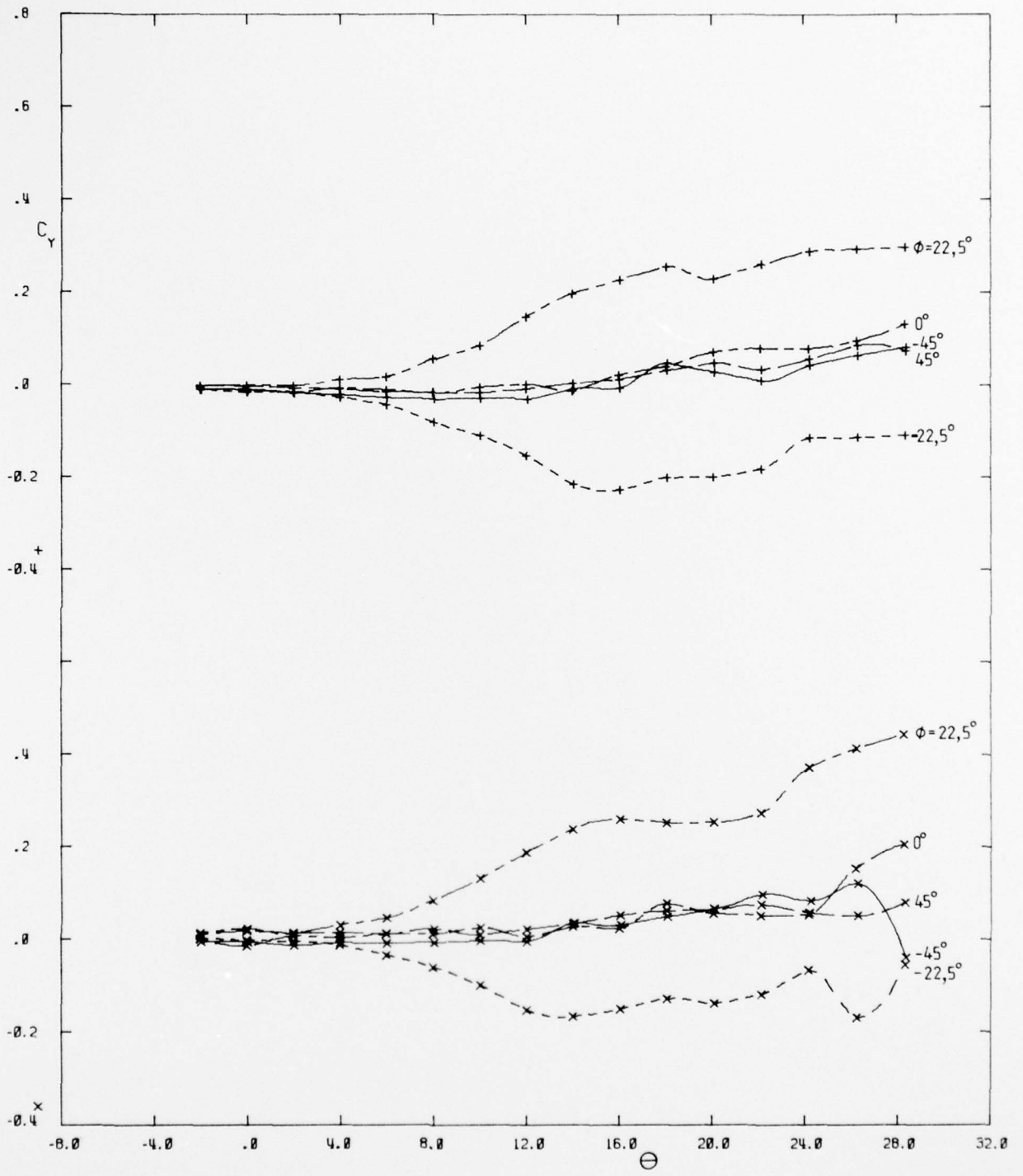

SYMBOL	M
x	.95
+	1.20

REY = .150 * 10⁶

FIG. 11 VARIATION OF SIDE FORCE COEFFICIENT WITH THETA
EFFECT OF ROLL ANGLE

DISTRIBUTION

AUSTRALIA

DEPARTMENT OF DEFENCE

Copy No.

Central Office

Chief Defence Scientist	1
Executive Controller, ADSS	2
Superintendent, Defence Science Administration	3
Defence Library	4
Joint Intelligence Organization	5
Assistant Secretary, DISB	6-21

Aeronautical Research Laboratories

Chief Superintendent	22
Superintendent - Aerodynamics Division	23
Divisional File - Aerodynamics Division	24
B.D. Fairlie)	25
L.J. Roberts)Authors	26
R.G. Broadbent)	27
Transonic Wind Tunnel Group	28 - 29
Library	30

Materials Research Laboratories

Library	31
---------	----

Weapons Research Establishment

Library	32
Mr K.D. Thomson	33

SPARES	34 - 43
--------	---------