

AD-A046 253

AVCO SYSTEMS DIV WILMINGTON MASS
PULSED ACOUSTIC VORTEX SENSING SYSTEM. VOLUME I. HARDWARE DESIG--ETC(U)
JUN 77 R N SCHWEIGER

F/G 17/1

DOT-TSC-620

UNCLASSIFIED

FAA-RD-75-161.1

NL

1 OF 2
ADA
046253

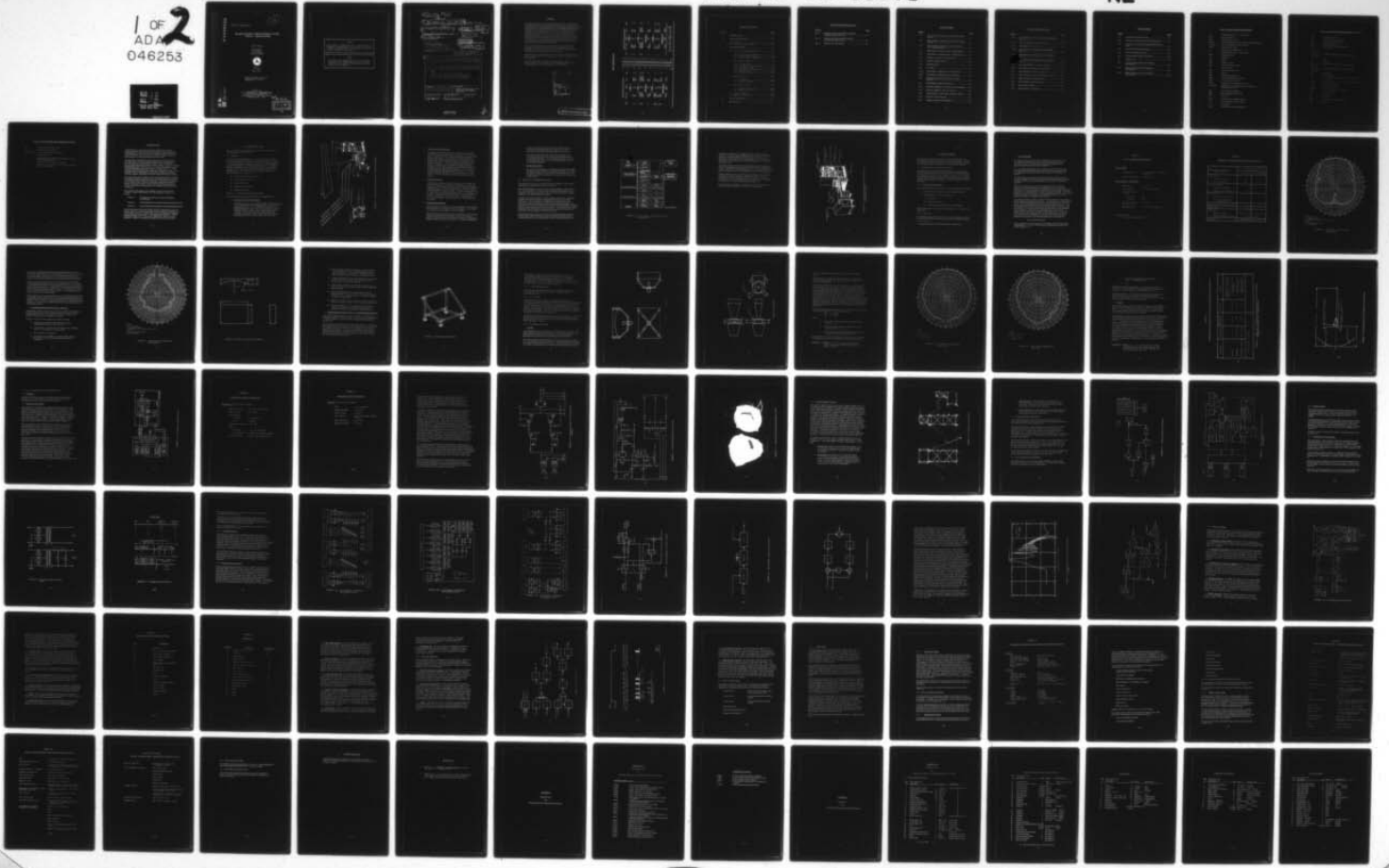

AD A 046253

12

REPORT NO. FAA-RD-75-161,I

PULSED ACOUSTIC VORTEX SENSING SYSTEM
Volume I: Hardware Design

Royal N. Schweiger

Avco Corporation
Systems Division
201 Lowell Street
Wilmington, MA 01887



JUNE 1977

FINAL REPORT

DOCUMENT IS AVAILABLE TO THE U.S. PUBLIC
THROUGH THE NATIONAL TECHNICAL
INFORMATION SERVICE, SPRINGFIELD,
VIRGINIA 22161

AD NO. _____
DDC FILE COPY

Prepared for
U.S. DEPARTMENT OF TRANSPORTATION
FEDERAL AVIATION ADMINISTRATION
Systems Research and Development Service
Washington DC 20591

DDC
RECEIVED
NOV 4 1977
B

NOTICE

This document is disseminated under the sponsorship of the Department of Transportation in the interest of information exchange. The United States Government assumes no liability for its contents or use thereof.

NOTICE

The United States Government does not endorse products or manufacturers. Trade or manufacturers' names appear herein solely because they are considered essential to the object of this report.

18 FAA-RD, MSC

19 75-161.1, FAA-74-19.1

Technical Report Documentation Page

1 Report No. FAA-RD-75-161.1	2 Government Accession No.	3 Recipient's Catalog No.
4 Title and Subtitle PULSED ACOUSTIC VORTEX SENSING SYSTEM Volume I - Hardware Design.	5 Report Date June 1977	6 Performing Organization Code
7 Author(s) Royal N. Schweigert	8 Performing Organization Report No. DOT-TSC-FAA-74-19.1	9
10 Performing Organization Name and Address Avco Corporation Systems Division 201 Lowell Street Wilmington MA 01887	11 Work Unit No. (TRAIS) FA405/R7126	12
12 Sponsoring Agency Name and Address U. S. Department of Transportation Federal Aviation Administration Systems Research and Development Service Washington DC 20591	13 Contract or Grant No. DOT-TSC-6206	14
15 Supplementary Notes * Under contract to: U. S. Department of Transportation Transportation Systems Center Kendall Square, Cambridge MA 02142	16 Final Report August 1973 - June 1974	17
18 Abstract Avco Corporation's Systems Division designed and developed an engineered Pulsed Acoustic Vortex Sensing System (PAVSS). This system is capable of real-time detection, tracking, recording, and graphic display of aircraft trailing vortices. This volume of the report presents hardware design aspects of the system. The design of the acoustic antenna and transducer is described. System control, computer hardware, and system/subsystem hardware interfaces are discussed. Other volumes in this final report are as follows: Volume II Studies of Improved PAVSS Processing Techniques Volume III PAVSS Operation and Software Documentation Volume IV PAVSS Program Summary and Recommendations		
17. Key Words Pulsed Acoustic Vortex Sensor, Wake Vortex, Trailing Vortex Sensing System, Aircraft Vortex Tracking System		18. Distribution Statement DOCUMENT IS AVAILABLE TO THE U.S. PUBLIC THROUGH THE NATIONAL TECHNICAL INFORMATION SERVICE, SPRINGFIELD, VIRGINIA 22161
19. Security Classif. (of this report) Unclassified	20. Security Classif. (of this page) Unclassified	21. No. of Pages 116
22. Price		

Form DOT F 1700.7 (8-72)

Reproduction of completed page authorized

404788

JB

PREFACE

The problems related to aircraft trailing vortices are currently under intensive study for the Federal Aviation Administration (FAA) by the U. S. Department of Transportation. The Transportation Systems Center (TSC) of the U. S. Department of Transportation (DOT) initiated and is carrying out several programs in this area, including programs to develop acoustic systems for detecting, tracking, and measuring the strength of aircraft wake vortices. The system described in this report was designed, built, and tested by Avco Corporation's Systems Division (Avco/SD) for DOT/TSC under Contract DOT-TSC-620, dated 15 August 1973. It is an engineered extension of the pulsed acoustic multi-static radar concept developed by the Communications Branch of DOT/TSC at Cambridge, Massachusetts.

The Avco-engineered system is designed to permit simultaneous operation of two (of three) 8-element arrays deployed along an appropriate baseline, and to provide real-time detection, tracking, recording, and graphic display of vortex locations.

This volume of the final report describes the design of the engineered system. Other aspects of the system are covered in additional volumes (II through IV).

The work performed under this contract was significantly enhanced by the close cooperation and contributions of Ralph Kodis, David Burnham, and Thomas Sullivan, all of DOT/TSC.

ACCESSION for		
NTIS	Write Section	<input checked="" type="checkbox"/>
DOC	Text Section	<input type="checkbox"/>
EXAMINED		<input type="checkbox"/>
INDEXED		
BY		
DISTRIBUTION/REGISTRATION UNIT		
Dist.	AVAIL	SPECIAL
A		

METRIC CONVERSION FACTORS

Approximate Conversions to Metric Measures		Approximate Conversions from Metric Measures	
When You Know	Multiply by	When You Know	Multiply by
LENGTH	LENGTH	LENGTH	LENGTH
inches	2.5	millimeters	0.04
feet	30	centimeters	0.4
yards	0.9	meters	3.3
miles	1.6	kilometers	1.1
			0.6
AREA	AREA	AREA	AREA
square inches	6.5	square centimeters	0.16
square feet	0.09	square meters	1.2
square yards	0.8	square kilometers	0.4
square miles	2.6	hectares (10,000 m ²)	2.5
acres	0.4		
MASS (weight)	MASS (weight)	MASS (weight)	MASS (weight)
ounces	28	grams	0.035
pounds	0.45	kilograms	2.2
short tons (2000 lb)	0.9	tonnes (1000 kg)	1.1
VOLUME	VOLUME	VOLUME	VOLUME
teaspoons	5	milliliters	0.03
tablespoons	15	fluid ounces	2.1
fluid ounces	30	pints	1.06
cups	0.24	quarts	0.26
pints	0.47	liters	35
quarts	0.95	cubic meters	1.3
gallons	3.8		
cubic feet	0.03		
cubic yards	0.76		
TEMPERATURE (exact)	TEMPERATURE (exact)	TEMPERATURE (exact)	TEMPERATURE (exact)
Fahrenheit temperature	5/9 (after subtracting 32)	Celsius temperature	9/5 (then add 32)

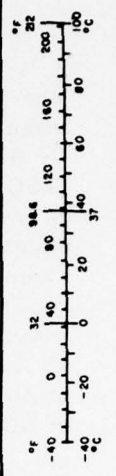
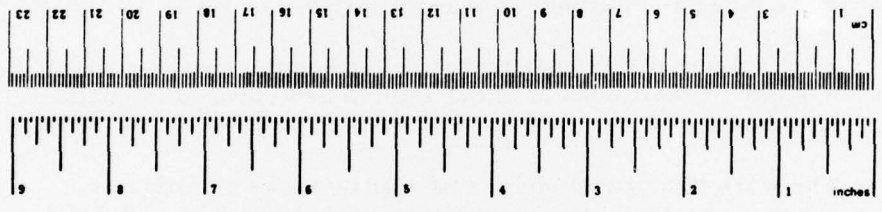

TABLE OF CONTENTS

<u>Section</u>		<u>Page</u>
1.	INTRODUCTION	1-1
2.	SYSTEM DESCRIPTION	2-1
2.1	General	2-1
2.2	Over-all System Description	2-4
3.	SUBSYSTEM DESIGN	3-1
3.1	Pulsed Acoustic Radar Subsystem	3-1
3.1.1	Acoustic Antenna Element	3-1
3.1.2	Antenna Support Structure	3-28
3.1.3	Signal and Power Distribution	3-30
3.2	Data Acquisition Subsystem	3-30
3.2.1	Isolation Module	3-33
3.2.2	Configuration Control Module	3-33
3.2.3	Line Driver Module	3-36
3.2.4	Analog Processor Modules	3-36
3.2.5	Radar Controller	3-46
3.2.6	Sync Decode Module	3-52
3.3	Display Subsystem	3-55
3.3.1	CRT Display	3-56
3.3.2	Hard-Copy Display	3-57
3.4	Data Storage Subsystem	3-57
3.4.1	Analog Tape Recorder	3-57
3.4.2	Digital Tape Recorder	3-60
3.5	Software Subsystem	3-64
3.6	Drawings and Parts Lists	3-64
4.	SYSTEM OPERATION	4-1
5.	REFERENCES	5-1

TABLE OF CONTENTS (Concl'd.)

<u>Section</u>		<u>Page</u>
App. A	DRAWING LIST FOR PULSED ACOUSTIC VORTEX SENSING SYSTEM	A-1
App. B	PARTS LIST FOR PULSED ACOUSTIC VORTEX SENSING SYSTEM	B-1
App. C	REPORT OF INVENTIONS	C-1

LIST OF FIGURES

<u>Figure</u>		<u>Page</u>
2-1	Pictorial View, Pulsed Acoustic Vortex Sensing System	2-2
2-2	Block Diagram, Pulsed Acoustic Vortex Sensing System	2-5
2-3	Control Station Arrangement, Pulsed Acoustic Vortex Sensing System	2-7
3-1	Final Pattern, Elevation Plane, PAVSS Antenna	3-5
3-2	Final Pattern, Azimuthal Plane, PAVSS Antenna	3-7
3-3	Reflector, Acoustic Antenna Element	3-8
3-4	Reflector Support Structure	3-10
3-5	Quadripod Mount	3-12
3-6	Feed Horn	3-13
3-7A	Feed Pattern, Elliptical Horn, Narrow Plane	3-15
3-7B	Feed Pattern, Elliptical Horn, Broad Plane	3-16
3-8	Sketch Showing Focal Point Relative to Horn Aperture	3-19
3-9	Block Diagram, Signal Electronics	3-21
3-10	Schematic Diagram, Transmitter Power Amplifier ..	3-25
3-11	Schematic Diagram, Receiver Circuit	3-26
3-12	Transmit/Receive Electronics Mounted in PD-60	3-27
3-13	Complete Tower Assembly	3-29
3-14	Cabling and Signal Flow Diagram	3-31

LIST OF FIGURES (Concl'd.)

<u>Figure</u>		<u>Page</u>
3-15	Block Diagram, Pulsed Acoustic Vortex Sensing System	3-32
3-16	Schematic Diagram, Isolation Module	3-34
3-17	Configuration Control Scheme	3-35
3-18A	Block Diagram, Configuration Control Module, Sheet 1	3-37
3-18B	Block Diagram, Configuration Control Module, Sheet 2	3-38
3-18C	Block Diagram, Configuration Control Module, Sheet 3	3-39
3-19	Schematic Diagram, Line Driver Module	3-40
3-20	Block Diagram, Analog Processor Module	3-41
3-21	Block Diagram, Synchronous Detector	3-42
3-22	Synchronous Detector Transfer Characteristics	3-44
3-23	Maximum Rate Threshold Detector	3-45
3-24	Block Diagram, Radar Controller	3-47
3-25	Sync Decoder Module	3-53
3-26	Data Transfer Configuration	3-54

LIST OF TABLES

<u>Table</u>		<u>Page</u>
3-1	Acoustic Sensor Requirements	3-3
3-2	Summary of Requirements for Field Equipment	3-4
3-3	Comparison of Measured and Calculated Antenna Data	3-18
3-4	Transmitter Design Parameters	3-22
3-5	Receiver Design Parameters	3-23
3-6	Command Status Register Functions	3-49
3-7	Address List	3-50
3-8	Versatec Electrostatic Printer/Plotter Specifications	3-58
3-9	Analog Tape Recorder--Performance Specifications	3-61
3-10	Digital Tape Recorder--Performance Specifications	3-62

LIST OF ABBREVIATIONS AND SYMBOLS

A	Programmable frame - frame period
A/D	Analog-to-digital
AGC	Automatic gain control
ASCII	American Standard Code for Information Interchange
Avco/SD	Avco Corporation, Systems Division
AWG	American wire gauge
b	Magnitude of illumination at $\rho = 1$
B	Programmable frame - pulse length
BOT	Beginning of tape
C _n	Capacitor n
CR _n	Diode n
CRT	Cathode ray tube
CSR	Command status register
D	Reflector chord
DAS	Data acquisition system
dB	Decibel
DDS	Data display subsystem
DEC	Digital Equipment Corporation
DMA	Direct memory address
DOT	Department of Transportation (U.S.)
DOT/TSC	Department of Transportation, Transportation Systems Center (U.S.)
DSS	Data storage subsystem
EMI	Electromagnetic interference
EOR	End of run
FAA	Federal Aviation Administration
F/D	Focal length to diameter ratio
F _n	Frequency n
GFE	Government-furnished equipment

LIST OF ABBREVIATIONS AND SYMBOLS (Continued)

hit	Acoustic data pulse
Hz	Hertz (one cycle per second)
ID	Identity (or identification)
ips	Inch(es) per second
IRIG	Inter-Range Instrumentation Group
J-box	Junction box
Jn ←	Terminal n (notation used on Figure 3-18)
Jn >	
→ Jn	
← Jn	
k	1000
kHz	Hz x 1000
Kn $\begin{array}{c} \text{+} \\ \text{---} \\ \text{-} \end{array}$	Relay n, contacts open, contacts closed
Kn >	Terminal n (notation used on Figure 3-18)
→ Kn	
← Kn	
M	1,000,000
MHz	Hz x 1,000,000
n	A sequentially assigned integer, e. g. R28 is the 28th resistor
NAFEC	National Aviation Facilities Experimental Center
NRZ	Non-return to zero
Op amp	Operational amplifier
PARS	Pulsed acoustic radar subsystem
PVC	Polyvinyl chloride
Qn	Transistor n
Rn	Resistor n
RTV	Room temperature vulcanizing
SOR	Start of run

LIST OF ABBREVIATIONS AND SYMBOLS (Concluded)

TSC	Transportation Systems Center
TTL	Transistor-transistor logic
X, Y, and Z	Acoustic radar arrays X, Y, and Z
Z _n	Integrated circuit n
η	A dimensionless quantity that determines the rate of aperture illumination taper
λ	Wavelength at the frequency of interest
ρ	Normalized radial distance of the aperture from the center of the reflector.

1. INTRODUCTION

Trailing vortices from heavy jet aircraft represent a currently undefined hazard, particularly during landing and takeoff operations. Considerations of safety and the need to optimize airport operations make it essential to acquire positive information about the presence and locations of vortices generated by heavy aircraft.

The feasibility of using multi-static pulsed acoustic radar to detect and track wake vortices has been demonstrated by the Department of Transportation's Transportation Systems Center (DOT/TSC) in tests at Logan International Airport, Boston, Mass., at John F. Kennedy International Airport, New York, N. Y., and at the National Aviation Facilities Experimental Center (NAFEC), Atlantic City, N. J. The hardware used during these tests consisted of laboratory models. The equipment was not engineered for long-term installation in the field, and was incapable of automatic real-time data processing and display.

This report describes a pulsed acoustic vortex sensing system (PAVSS) development program carried out by Avco Systems Division (Avco/SD) for DOT/TSC under Contract DOT-TSC-620. The goal of this program was to develop, build, and test an engineered wake vortex sensing system consisting of acoustic sensors and associated electronics; to acquire and process the sensed data; and to display this data visually in real time.

The complete final report on this program consists of this volume (Volume I, HARDWARE DESIGN) and three additional volumes, as follows:

- | | |
|------------|---|
| Volume II | STUDIES OF IMPROVED PAVSS PROCESSING TECHNIQUES |
| Volume III | PAVSS OPERATION AND SOFTWARE DOCUMENTATION |
| Volume IV | PAVSS PROGRAM SUMMARY AND RECOMMENDATIONS |

In this first volume of the final report, Section 2. describes the over-all system, Section 3. discusses the design of the individual subsystems and sub-elements, Section 4. identifies the source of information regarding system operation, and Section 5. lists appropriate references. Three appendixes (Appendix A, Drawing List; Appendix B, Parts List; and Appendix C, Report of Inventions) complete this volume of the report.

2. SYSTEM DESCRIPTION

This section describes the Pulsed Acoustic Vortex Sensing System (PAVSS) from a systems viewpoint.

2.1 GENERAL

The PAVSS consists essentially of three 8-element acoustic radar antenna arrays and all the hardware, software, and interface items necessary for real-time acquisition, reduction, readout, and display of vortex position data. Analog and digital data is stored on magnetic tape for subsequent off-line reduction and evaluation. The system contains a minicomputer that not only performs the required PAVSS functions but also can interface with other external computers or control systems. The system may be considered to consist of the following-listed basic subsystems:

- Pulsed acoustic radar subsystem
- Data acquisition subsystem
- Display subsystem
- Data storage subsystem
- Software subsystem

Figure 2-1 is a pictorial overview of the PAVSS.

Brief functional descriptions of each of these subsystems follow.

a. Pulsed Acoustic Radar Subsystem

The pulsed acoustic radar subsystem consists of three arrays, each containing eight transceiving elements. Each transceiver element consists of: (1) transmitter drive and receiver/gating preamplification electronics, (2) an electro-acoustic transducer, (3) an antenna, (4) a transportable mounting structure, and (5) interconnecting cables. The array elements are designed to allow three independent arrays to be deployed, each with baseline lengths up to 2000 feet.

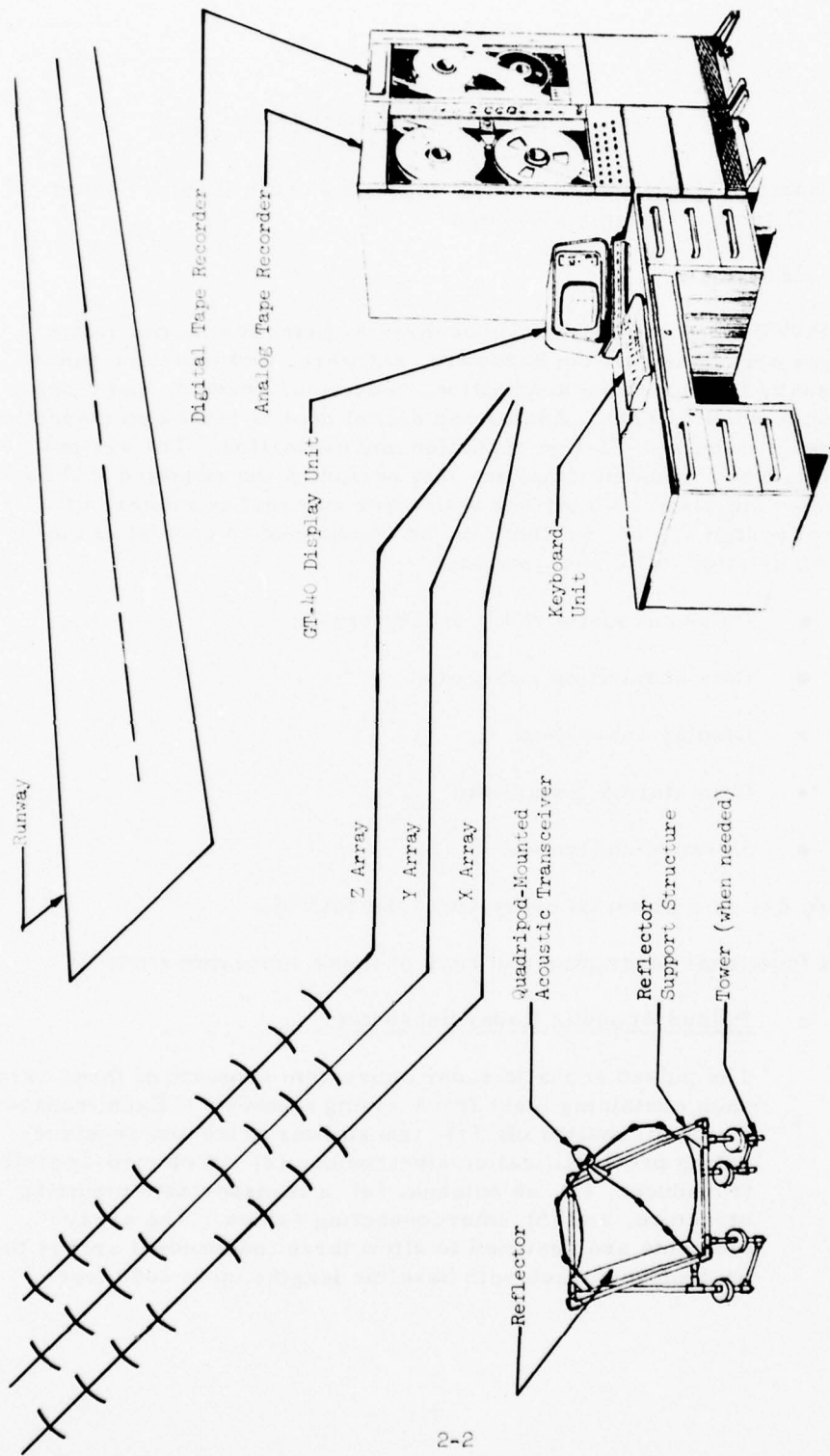

2-2

FIGURE 2-1 Pictorial View, Pulsed Acoustic Vortex Sensing System

b. Data Acquisition Subsystem

The data acquisition subsystem contains the minicomputer and all of the electronic equipment needed to: (1) select an array configuration, (2) generate modulation waveforms and gate control signals, (3) receive and detect transmitted signals, (4) extract time-delay data, (5) determine vortex position information, and (6) control the data storage and display subsystems. The minicomputer performs these functions automatically in response to computer programs generated off-line and entered into the computer memory via a digital magnetic tape recorder interface. The system is also controlled by appropriate keyboard inputs. The minicomputer provides 16,000 (16K) words of memory. A data link to a central controller permits remote control of the system.

c. Display Subsystem

The display subsystem consists essentially of a cathode ray tube (CRT) display. Provisions are included for a hard-copy display to allow printout of selected data, computer calculations, and graphic data. The CRT display device is used to display vortex position data from an array. The CRT display operates in a real time, two-dimensional mode--that is, it displays, for example, altitude and horizontal displacement with respect to a runway centerline as a function of time. Alternatively, it can be used to display vortex track motion--either horizontal or vertical.

d. Data Storage Subsystem

The data storage subsystem consists essentially of two magnetic tape recorders, one analog and the other digital. The former is a 14-track unit, the latter a 7-track recorder.

The analog recorder provides direct recording of pre-amplified receiver signals (acoustic returns), array time-reference signals, run initiation and run identification data, configuration definition data, and voice commentary. It includes appropriate

playback capability to allow directly recorded signals to be processed and displayed in the same way as data is processed and displayed during operations in real time.

The primary function of the digital tape recorder is to store time-delay and vortex position data during periods of unattended operation. Its secondary function is to serve as an input/output device to facilitate loading and readout of computer programs.

e. Software Subsystem

The software subsystem, or package, consists of all program listings and tapes required to operate the PAVSS, to produce the graphic displays, and to record vortex track data. The complete software documentation is presented in Volume III of this report.

2.2 OVER-ALL SYSTEM DESCRIPTION

This section presents the over-all design of the PAVSS. The various subsystems are described in detail in Section 3.

The PAVSS hardware system is shown in block diagram form in Figure 2-2. As noted above, it consists of the following-listed subsystems: pulsed acoustic radar subsystem, data acquisition subsystem, display subsystem, and data storage subsystem.

Basically, the pulsed acoustic radar subsystem consists of a parabolic cylinder reflector activated by a quadripod-mounted, center-feed transceiver. This assembly is designed to be mounted on a tower structure capable of providing several levels of installed height. The transducer is an Atlas PD-60 acoustic transducer with internally mounted driver (transmitter) and receiver electronics. The pulsed acoustic radar subsystem also includes the cabling necessary to provide power to the array and to carry signals to and from the array.

The data acquisition subsystem consists of all the elements needed to control system operation (upon receipt of external data either from a central processor or local keyboard), solve for vortex locations, and

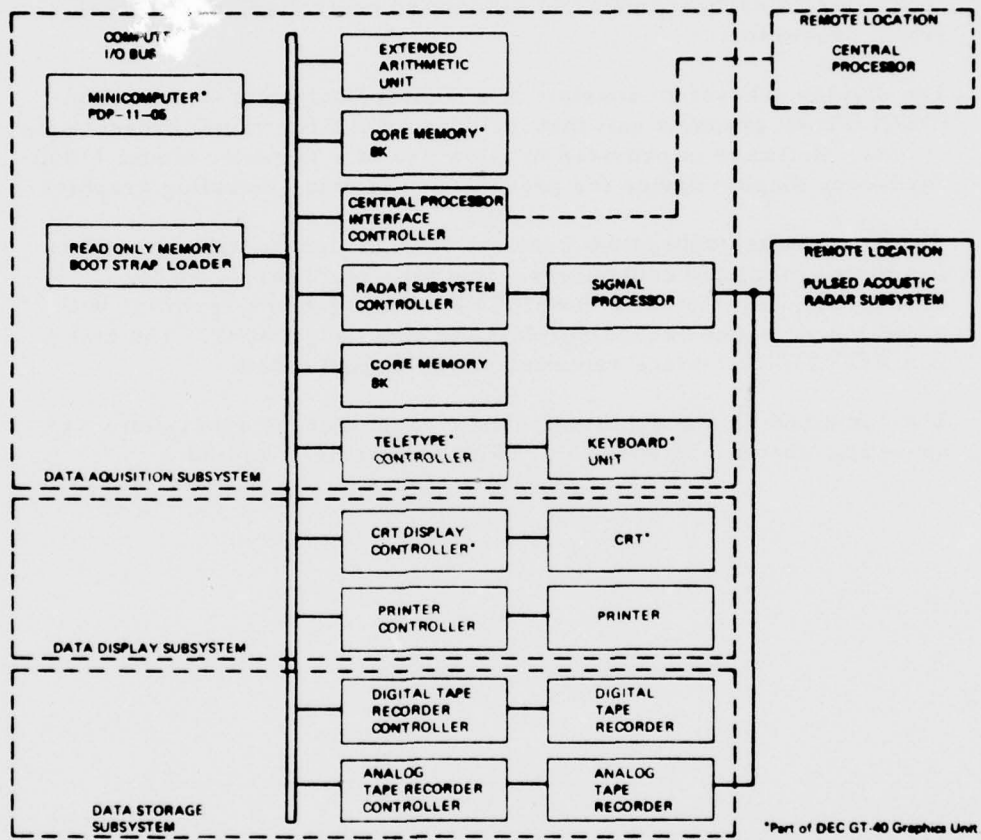

FIGURE 2-2 Block Diagram, Pulsed Acoustic Vortex Sensing System

feed data to the display or storage subsystems. Data acquisition subsystem elements include a PDP-11/05 minicomputer, a bootstrap loader, an extended capability arithmetic unit, a core memory (additional to that provided in the minicomputer), a radar subsystem controller, a keyboard unit and associated controller, and an analog signal processor.

The display subsystem consists of a Digital Equipment Corporation (DEC) GT-40 graphics unit that includes a CRT for visual presentation of data. Software is provided to allow use of a Versatec Model 1100A hard-copy display device for presentation of data, including graphics.

The data storage subsystem consists of two magnetic tape recorders and their associated controllers. One tape recorder, used for analog data, is a Bell and Howell CPR-4010 14-track recorder with provision for voice recording/playback on an edge track. The other is a DEC TU-10 7-track recorder used for digital data.

The combined data acquisition, display, and storage subsystems are housed as shown in Figure 2-3. (The desk is not supplied.)

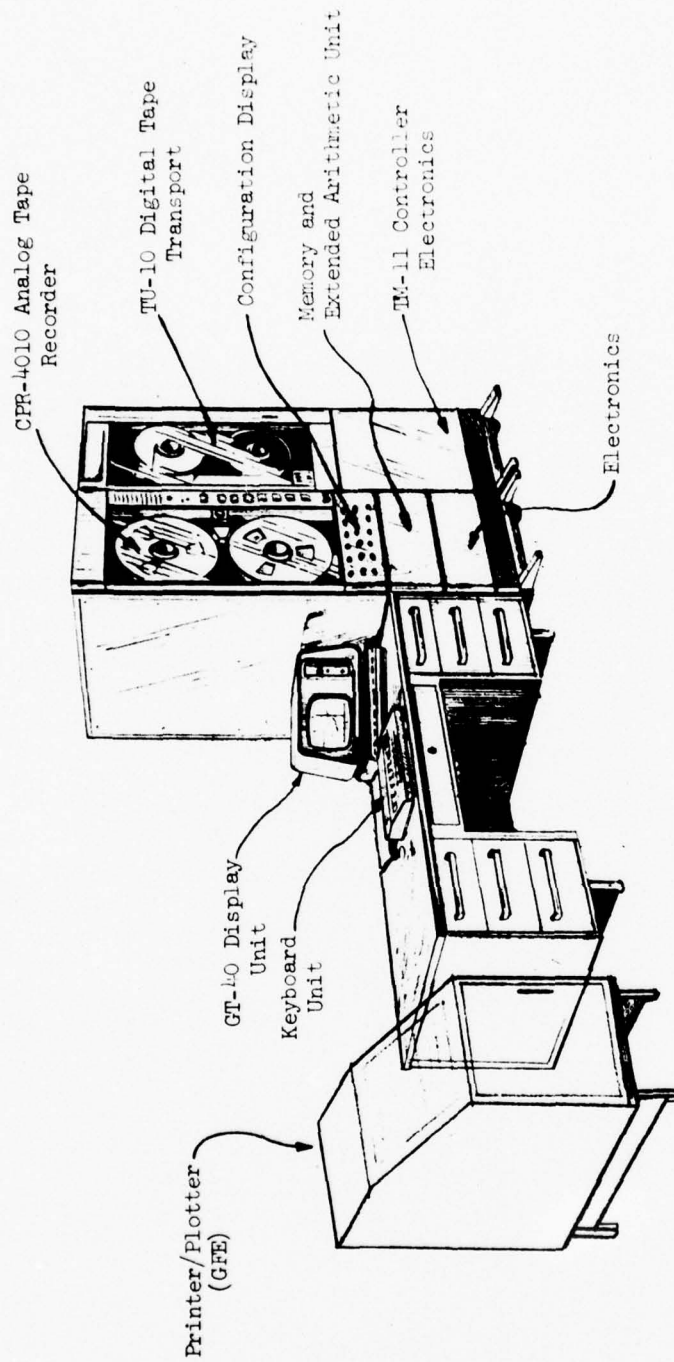

FIGURE 2-3 Control Station Arrangement, Pulsed Acoustic Vortex Sensing System

22

3. SUBSYSTEM DESIGN

This portion of the final report includes detailed discussions and descriptions of the design of each subsystem of the PAVSS. It should be noted that the drawings referred to in Appendix A (but not included in this report*) define the hardware in detail as finally designed.

3.1 PULSED ACOUSTIC RADAR SUBSYSTEM

The pulsed acoustic radar subsystem (PARS) consists essentially of an acoustic antenna element, complete with an acoustic transducer and associated electronics, and a support structure. It also includes the required interconnecting signal and power cabling. The acoustic antenna element, support structure, and signal and power distribution scheme are described in Paragraphs 3.1.1, 3.1.2, and 3.1.3, respectively.

3.1.1 Acoustic Antenna Element

The acoustic antenna element consists of the following-listed components:

- a. Reflector and associated reflector support structure
- b. Quadripod subassembly, composed of:
 - 1) Quadripod
 - 2) Elliptical feed horn
 - 3) Driver and associated transceiver electronics

These major items are described in Paragraphs 3.1.1.1 and 3.1.1.2, respectively.

3.1.1.1 Reflector

The following paragraphs describe first the acoustic design and then the mechanical design of the reflector and reflector support structure.

* Furnished under Item 8, PAVSS Drawings and Parts List.

a. Acoustic Design

The reflector design selected for the PAVSS was chosen on the basis of its ability to satisfy the acoustic radiation pattern requirements specified in Table 3-1 and the field equipment environmental and physical design requirements listed in Table 3-2.

As a concomitant design goal, Avco sought to provide a system whose over-all performance would equal or exceed that of the equipment TSC was operating in the field at the time the contract for the PAVSS was awarded.

The TSC design was evaluated in Avco/SD's acoustic antenna facility. The data from this test effort indicated that the elevation plane beamwidth requirement (60°) could not be satisfied by TSC's offset-fed reflector approach.

Extensive evaluation tests on the TSC-designed reflector with feed location as the variable parameter indicated that use of a center-fed reflector could solve the problem of meeting the elevation plane beamwidth requirement. A solution based on using the same focal length to diameter (F/D) ratio used by TSC ($33/52 = 0.635$) was finally achieved. The required reflector, however was longer in the cylinder plane than was the TSC antenna (58 inches as compared with 36 inches).

The reflector design was then reviewed from the viewpoint of the environmental and physical design requirements. In response to a recommendation by TSC the design parameters were reconsidered to determine the feasibility of using a reflector with a 36-inch parabolic plane dimension. This would effectively decrease wind loads on the reflector in a typical airport environment. As a result of this review another reflector was fabricated. It was designed to retain the same subtended angle as the previous reflector at the focus of the reflector in the cylinder plane. In the new reflector the 58-inch reflector's focal length to diameter ratio ($33/58$) was scaled down to accommodate the new reflector's parabolic plane dimension of 36 inches. The resultant design has a focal length of

$$(33 \times 36)/58 = 20 \text{ inches}$$

The new reflector was then tested with an elliptical feed horn (described in Paragraph 3.1.1.2.2). A 60° elevation beamwidth was achieved, as shown in Figure 3-1.

TABLE 3-1

ACOUSTIC SENSOR REQUIREMENTS

ARRAY SYSTEM

Configuration	3 linear arrays, 8 elements per array
Array Element Mode	Transceiver

ARRAY ELEMENT - ACOUSTICAL

Frequency	1 to 4 kHz
Pulse Length	2 to 5 milliseconds
Beamwidth (Fan) at 3.0 kHz	
Elevation	60°
Azimuthal	5° *
Sidelobes (at 3.0 kHz, $\theta > 45^\circ$)	≤ 30 dB
Transmit Power	100 watts (electrical)

* Subsequently changed to 6.0°.

TABLE 3-2

SUMMARY OF REQUIREMENTS FOR FIELD EQUIPMENT

Environmental or Physical Design Parameter	Subsystem Condition	
	Operating	Non-Operating
Temperature		
High (degrees, F)	125	140
Low (degrees, F)	-40	-65
Relative Humidity		
Percent, condensing	0 to 100	
Temperature (degrees F)	75 to 85	
Precipitation		
Rain (inches per hour)	0.3	1.0
Snow Load (pounds per square foot)	20	
Wind, Steady (miles per hour)	35	75
Useful Life	One Year	
Reflector		
Elevation Angles	$45^{\circ} \pm 15^{\circ}$ from the horizontal	
Support Elevation Heights	0, 5, and 10 feet	
Materials	As non-metallic as practical	

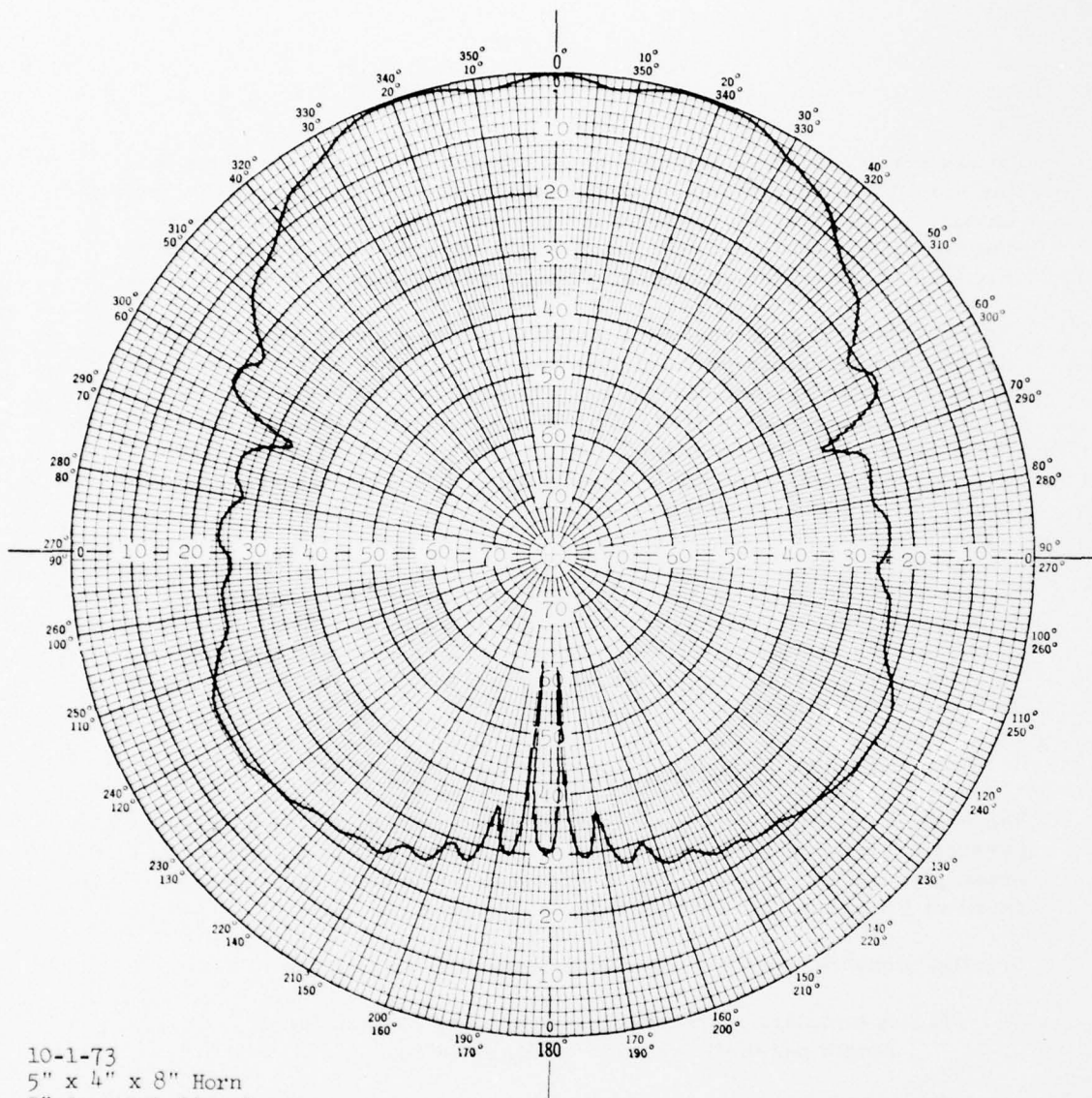

10-1-73
 5" x 4" x 8" Horn
 5" in parabolic plane
 36" parabolic x 52" cylindrical reflector
 3 kHz
 3 millisecond pulse width
 19.5 focal length

FIGURE 3-1 Final Pattern, Elevation Plane,
PAVSS Antenna

It was also considered that this reflector design adequately satisfied the sidelobe requirements in the azimuthal plane since it met the specified levels at all angles except for a few discrete angular regions where the sidelobe levels were only from 1 to 2 dB above the specified levels. Figure 3-2 shows the azimuthal plane pattern achieved with this design.

Both theoretical considerations and test measurements indicated that the required sidelobe performance was unattainable with a 5° beamwidth in the azimuthal plane unless a larger-diameter reflector with resultant higher directivity were used. On the basis of these findings the azimuthal plane beamwidth requirement listed in Table 3-1 was revised (from 5° to 6°) to reflect the beamwidth actually attained. The only apparent disadvantage is a decrease in antenna gain.

On the other hand, it is expected that use of the 6° beamwidth will provide an advantage in that it will improve system performance margins when the potential effects of turbulence--which could produce beam wandering due to changes in the coherency of the signal distribution at the aperture--are considered. In general, these effects become much more pronounced as the beamwidth decreases.

b. Mechanical Design and Construction - Reflector

The reflector, shown in Figure 3-3, consists essentially of a cylindrical parabolic honeycomb sandwich integrally bonded to a braced, marine-grade plywood box frame. The reflector is 36 inches high and has a chord of 52 inches and a focal length of 20 inches.

Briefly, construction of the reflector proceeds as follows:

- 1) A template is prepared to define the 20-inch focal length parabolic surface of the reflector.
- 2) A wooden form is constructed in the shape of the reflecting surface. The template is used as a guide.
- 3) The box frame is constructed.
- 4) All surfaces to be bonded are coated with epoxy adhesive (thickened with Cabosil to provide good fillets at all interfaces).

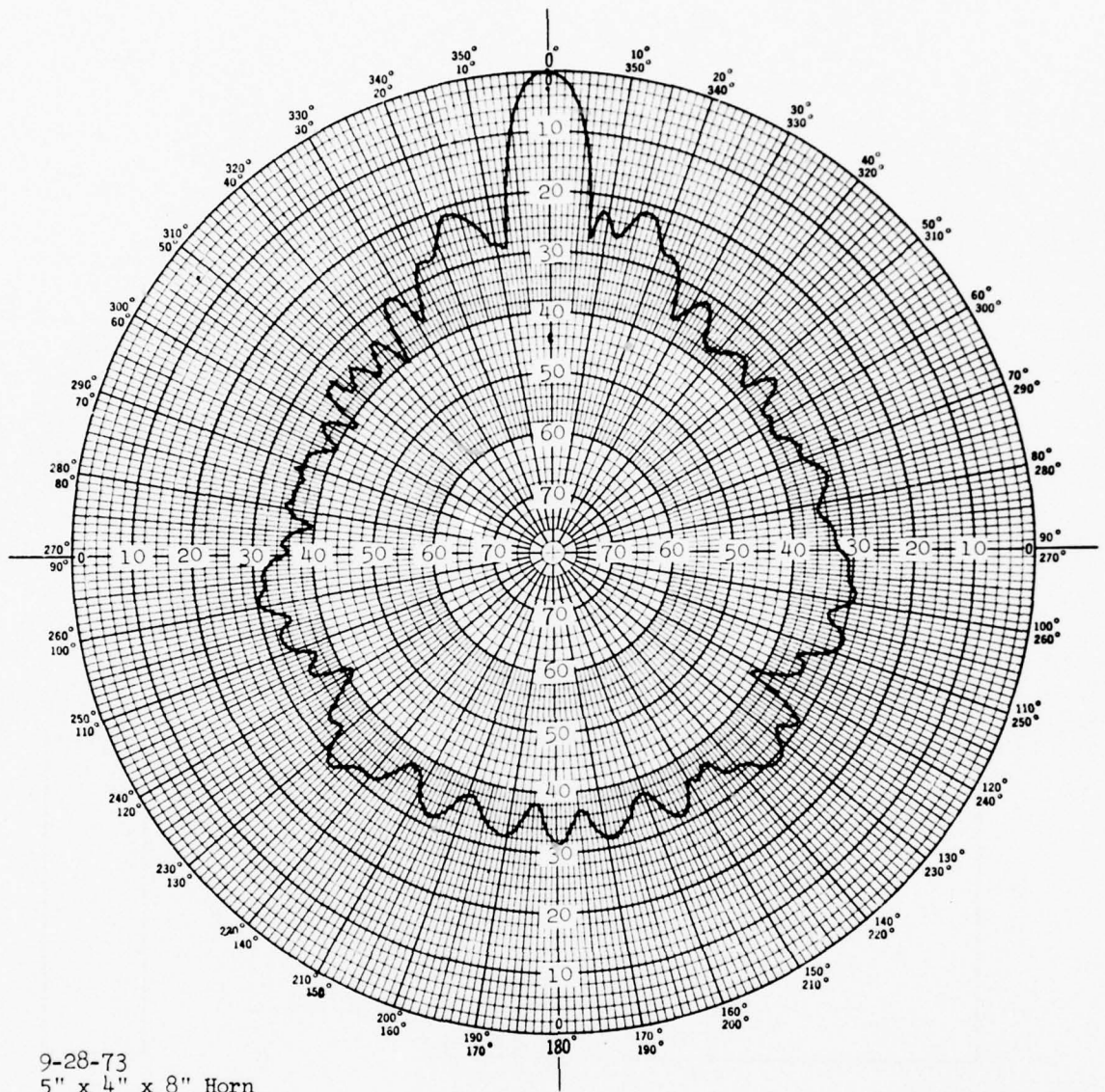

9-28-73
 5" x 4" x 8" Horn
 5" in parabolic plane
 36" parabolic x 52" cylindrical reflector
 3 kHz
 3 millisecond pulse width
 19.5 focal length

FIGURE 3-2 Final Pattern, Azimuthal Plane, PAVSS Antenna

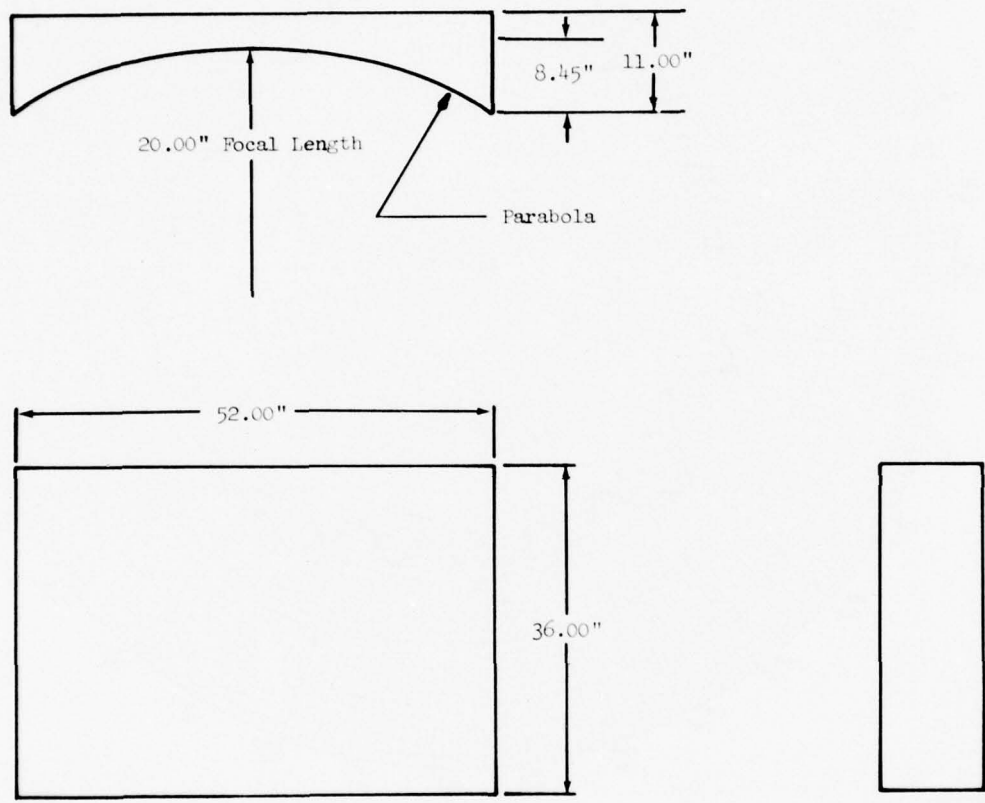

FIGURE 3-3 Reflector, Acoustic Antenna Element

- 5) The honeycomb sandwich (consisting of a 1/32-inch sheet of G-10 fiberglass, 1-inch thick Kraft paper honeycomb, and another sheet of 1/32-inch G-10 fiberglass) is then laid up, together with the box frame, on the wooden form.
- 6) Weights (sand bags) are placed appropriately to insure proper contact between the various items, and the assembly is placed in an oven to cure the adhesive.
- 7) When curing is complete, the material is trimmed to size where necessary, then sanded, and all joints are filled with polyester putty.
- 8) Holes are drilled for the "U" bolts used to secure the quadripod to the reflector and for the hinges used to secure the reflector to its support structure. A suitable template is used as a drilling guide.
- 9) After the assembly has been completed and finish-sanded it is painted, first with a priming coat and then with a finish coat.
- 10) Finally--although this is not strictly part of the reflector construction process--the quadripod is mounted and the assembly is installed in the reflector support structure.

c. Mechanical Design and Construction - Reflector Support Structure

The reflector support structure, shown in Figure 3-4, is designed to support the reflector at various angles of elevation either at ground level or, when secured to the tower structure, at discrete heights above ground level.

The structure is assembled from 2-in (nominal) diameter, Schedule 80 polyvinyl chloride (PVC) pipe and fittings. All joints are solvent welded. The support structure is assembled over appropriate jigs to insure dimensional repeatability. The legs of the structure end in flanged fittings drilled to match corresponding holes in spike angles (used for ground level installations) or in mating flanges on the tower structure (for installation above ground level).

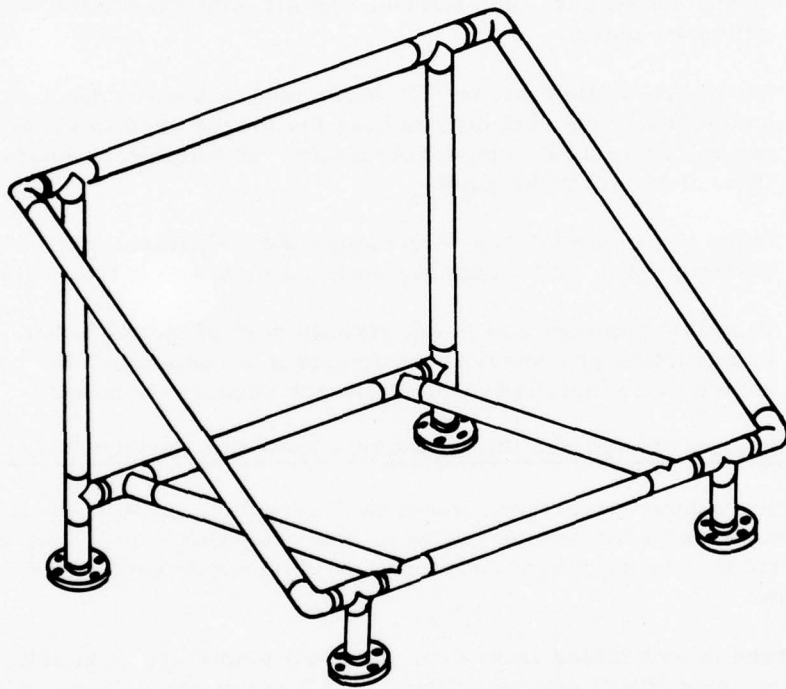

FIGURE 3-4 Reflector Support Structure

The reflector is attached to the support structure at 4 points--two in the horizontal plane and two in the vertical plane--via hinges. Once the desired elevation angle for the reflector is established the hinges are clamped to the support structure with "U" bolts. The elevation angle is a function of the acoustic antenna element's installed location along the array's azimuthal center line.

3.1.1.2 Quadripod Subassembly

The quadripod subassembly consists of the quadripod itself, a feed horn, and an electro-acoustic transducer, or driver, with its associated electronics.

3.1.1.2.1 Quadripod

The quadripod, shown in Figure 3-5, supports the feed horn and transducer at the proper location relative to the reflector. It is constructed of a 1-inch thick PVC hub and four legs. The latter are fabricated from 1-inch (nominal) diameter, Schedule 80 PVC pipe and 45° PVC angle fittings. The leg elements are reinforced with wooden dowels to increase the assembly's rigidity. They are assembled over a suitable jig and all joints are solvent welded. The horn is bolted to the hub which is drilled and tapped to accommodate the transducer.

The legs of the quadripod fit over the box frame of the reflector. The entire quadripod assembly can be positioned for fine tuning (nominal location plus or minus 1 inch) if necessary. The assembly is secured to the box frame with eight "U" bolts.

3.1.1.2.2 Elliptical Feed Horn

a. Design

The feed horn selected for the PAVSS is elliptical in cross section. This design approach was selected to permit the illumination efficiency of the reflector to be maximized by feed pattern control in the parabolic (azimuthal) and cylindrical (elevation) planes of the reflector.

The major and minor axis dimensions of the feed horn, shown in Figure 3-6, were initially selected on the basis of conical feed horn data collected in Avco/SD's acoustic antenna laboratory. The dimensions were finalized on the basis of the reflector's far field sidelobe and beamwidth response

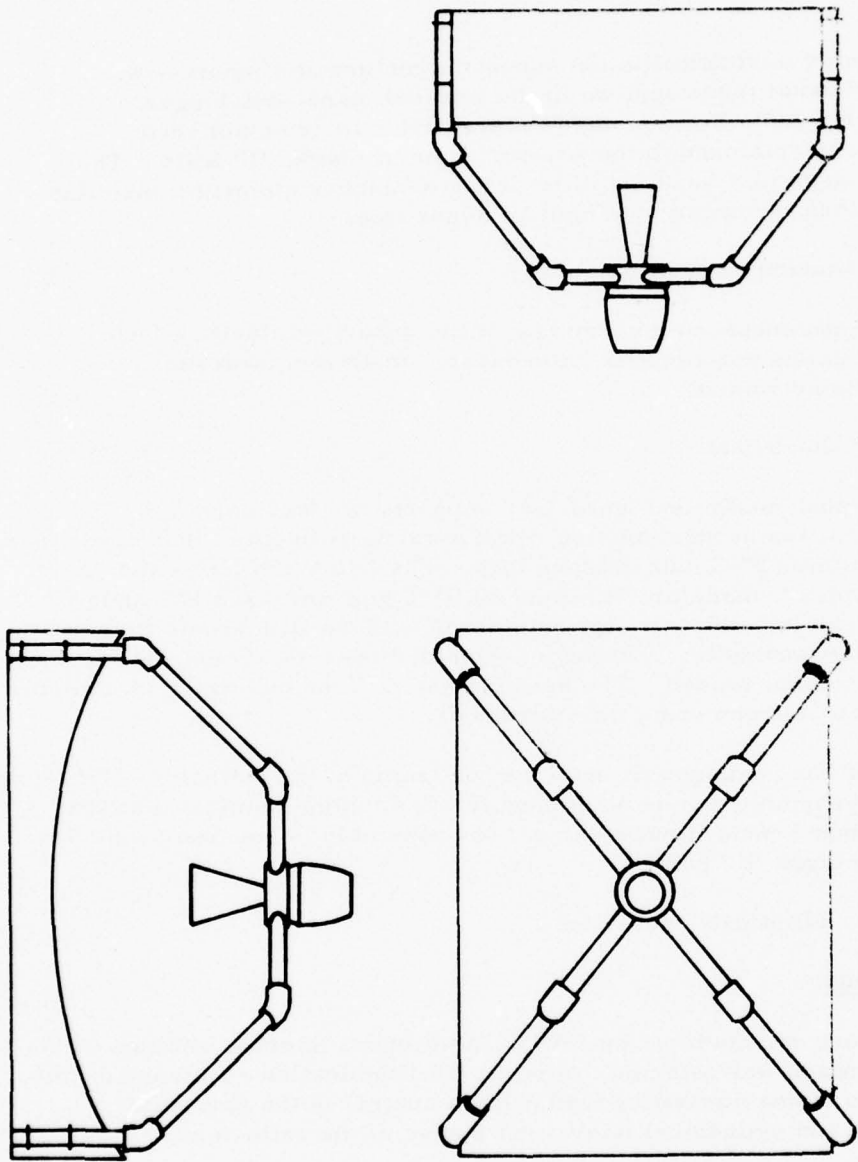

FIGURE 3-5 Quadripod Mount

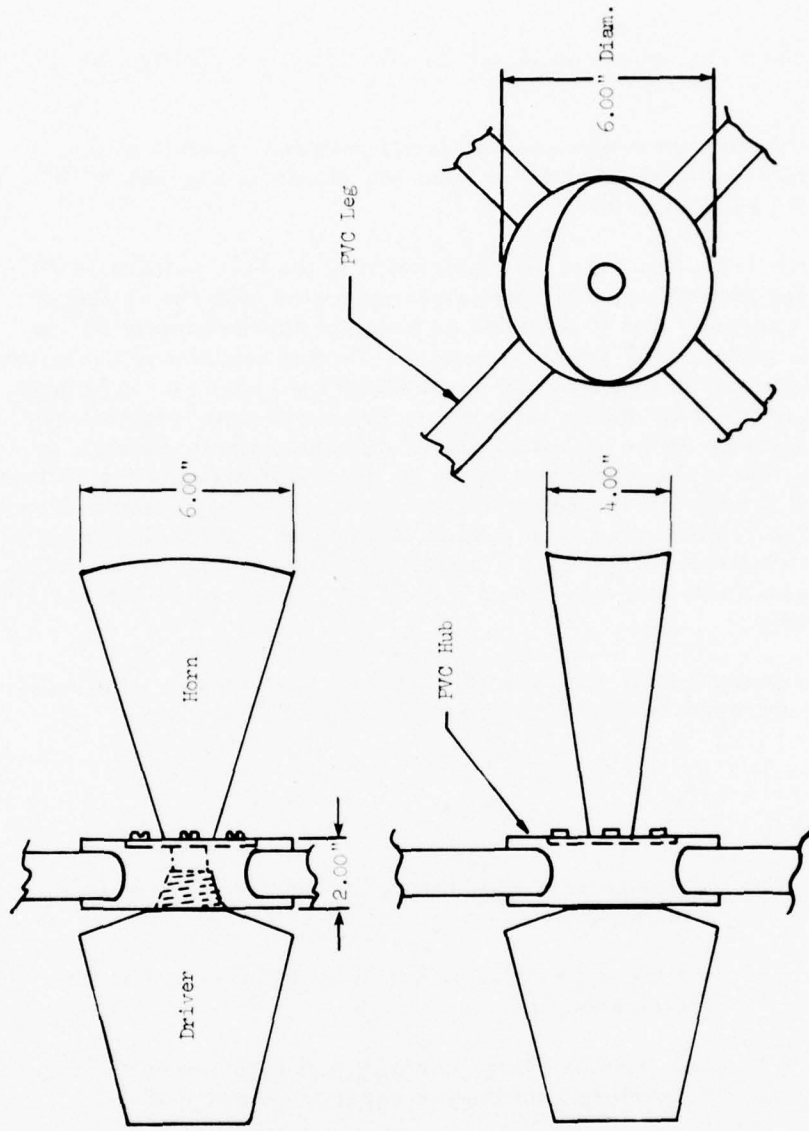

FIGURE 3-6 Feed Horn

in the azimuthal and elevation planes when fed by the elliptical horn.

The feed horn's elevation and azimuthal patterns, plotted at the design reference frequency of 3 kHz, are shown in Figures 3-7A and 3-7B, respectively.

As Figure 3-7A indicates, the beamwidth of the feed pattern is 70° in the elevation plane. This pattern is projected onto the reflector in such a manner that it subtends an angle of approximately 84° at the feed, giving a 60° far field pattern. During laboratory evaluations it was determined that the 3 dB level of the feed horn had to be kept well within the edge of the reflector to overcome any "edge effects" of the reflector in the elevation plane. Measurements showed, in general, that if the 3 dB point of the feed horn (desired in the reflector far field) intercepts the reflector from one to two wavelengths from the edges, the resulting far field pattern beamwidth will be the image of the feed horn's beamwidth. This beamwidth/reflector edge relationship is only approximate and empirical; it does not represent a hard and fast design rule.

In the azimuthal plane the feed horn pattern was tapered, representing an aperture distribution of the form (Reference 1):

$$b + \left[1 - (\rho / a)^2 \right]^n$$

where:

- ρ = Normalized radial distance on the aperture from the center
- b = Pedestal height (magnitude of illumination at the dish edge, that is $\rho = a$)
- η = A dimensionless quantity that determines the rate of aperture illumination taper (Reference 1)

An approximation to the measured data shown in Figure 3-7A yields the following-listed values for parameters b and η (Reference 1):

Reference 1. Hansen, R. C., Microwave Scanning Antennas, Volume I-Apertures, Academic, New York, N. Y., (1964), pp. 64-67.

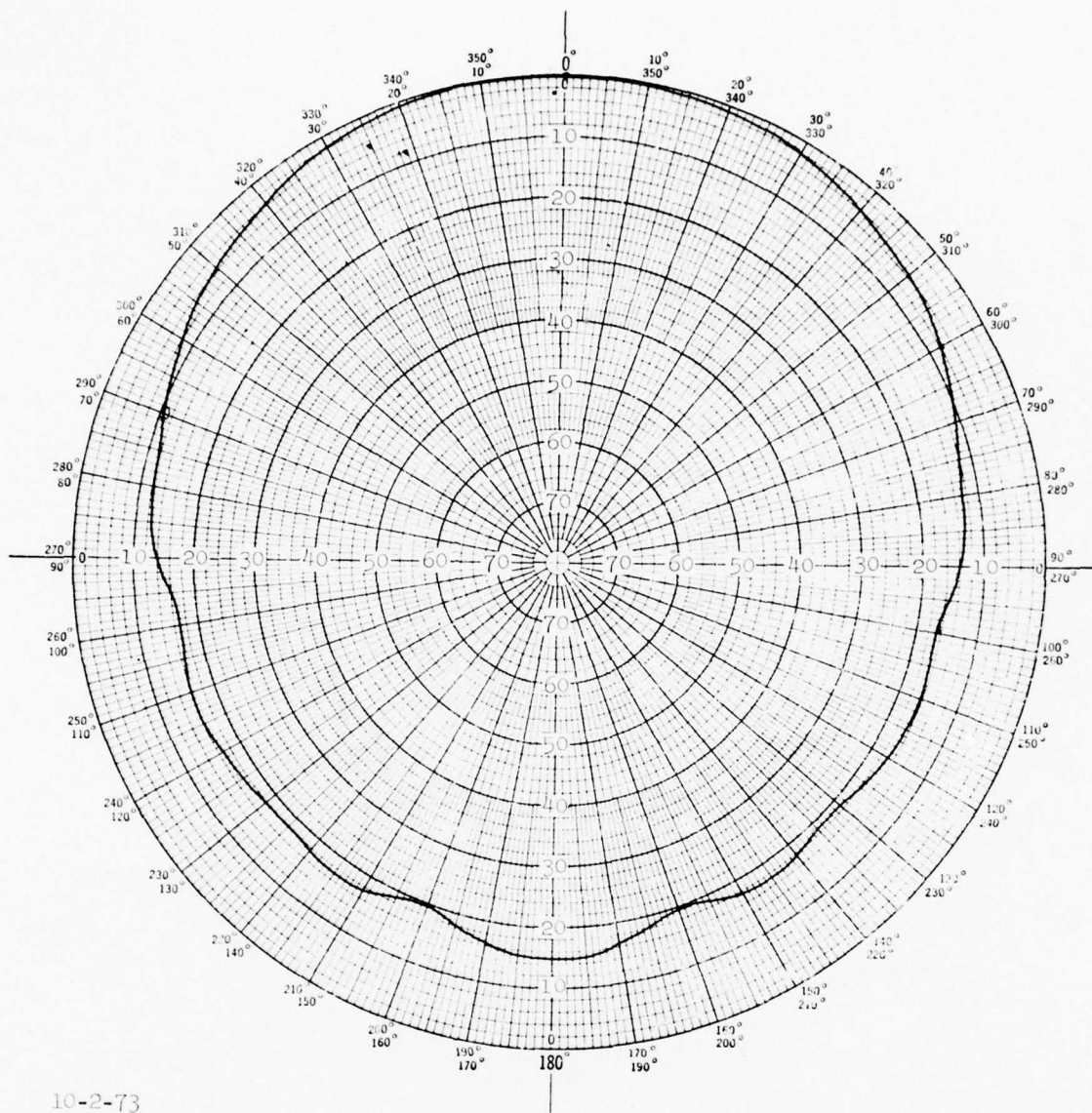

10-2-73
 3 kHz
 3.0 millisecond pulse
 2.0 Volts
 4" x 5" x 8" Horn
 4" (Narrow) Plane

FIGURE 3-7A Feed Pattern, Elliptical Horn,
Narrow Plane

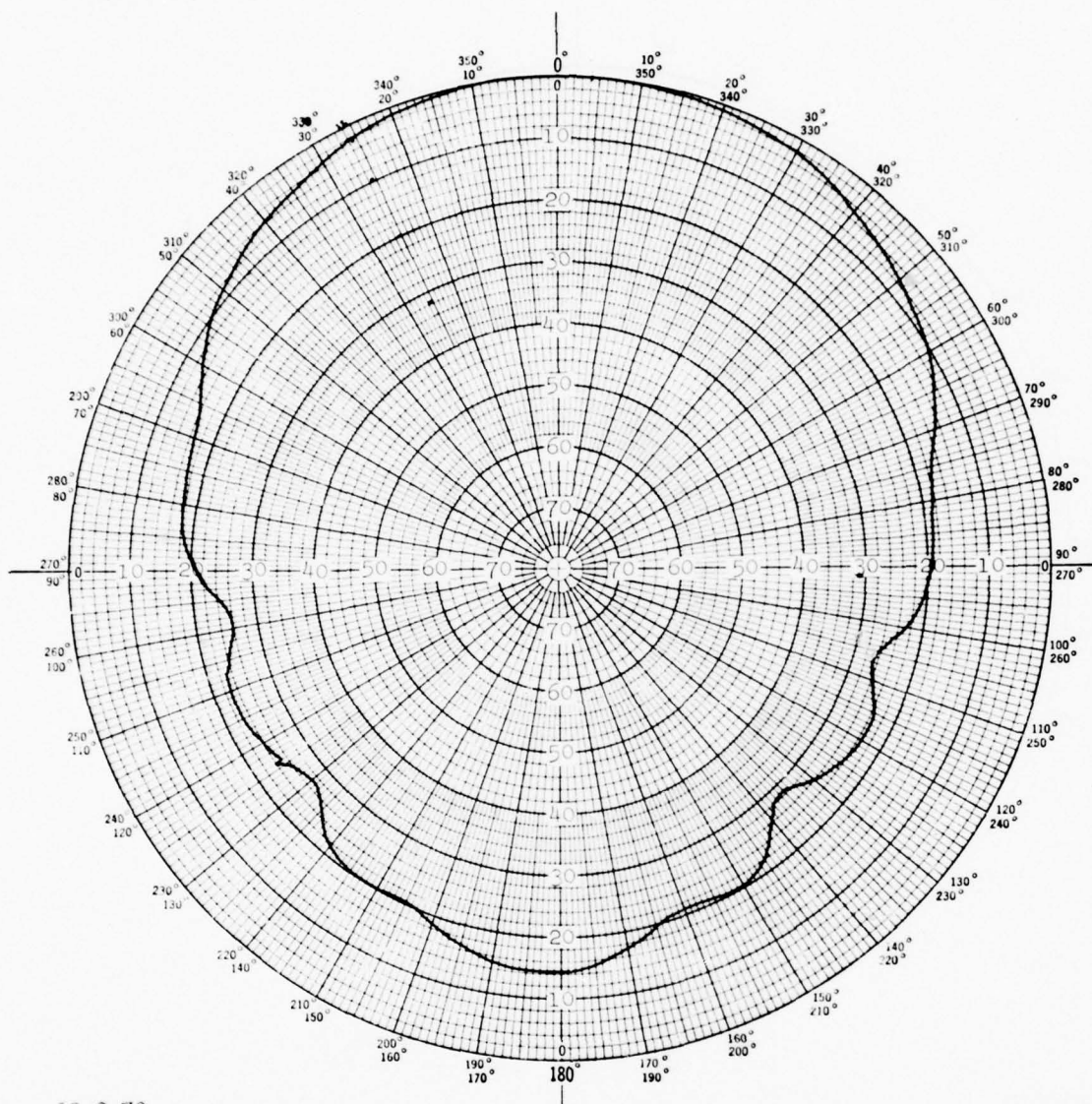

10-2-73
 3 kHz
 3.0 millisecond pulse
 2.0 Volts
 4" x 5" x 8" Horn
 5" (Broad) Plane

FIGURE 3-7B Feed Pattern, Elliptical Horn, Broad Plane

b = 1/4 (determined from a 10.0 dB pattern
taper + 3.5 amplitude taper)

η = 1.0

Interpolated sidelobe, beamwidth, and 1st null position data from Reference 1 can be compared with corresponding measured data from Figure 3-2. This comparison is summarized in Table 3-3.

As discussed above, a 5° beamwidth with appropriately suppressed sidelobes could be achieved only by increasing the directivity. This, in turn, requires an increase in reflector dimensions--a trade-off not considered warranted for this program.

b. Location

The acoustic antenna element is designed to operate in an environment where the vortex targets will be present at a distance greater than $2D^2/\lambda$, or 102 feet from the element (where D = reflector chord). This requires that the feed horn's acoustic phase center be located 20 inches from the reflector at its focal point.

The feed horn's phase center location has been defined on the basis of a combination of measured data and theoretical calculations. Test limitations required the antenna to be focussed at a distance of 50 feet, or D^2/λ . The patterns recorded represent the far field distribution of acoustic energy (Reference 2) although they were recorded with the focal point displaced from the true far-field focal point of 20 inches. This same reference describes the defocussing required to achieve focussing at a distance, R, from the parabolic aperture. From the curves given in that reference it was determined that the horn's position along the focal axis had to be reduced (moved in the direction toward the reflector) by 0.9 inch to be focussed in the far field. Figure 3-8 is a sketch showing these relationships and dimensions. Based on the results of these tests and calculations, the acoustic phase center of the elliptical horn in the broad plane is established as 1.4 inch inside the feed horn aperture.

Reference 2. Johnson, R. C., H. A. Ecker and J. S. Hollis, Determination of far field antenna patterns from near field measurements, Proc. IEEE, 61 (12), December 1973, pp. 1668-1694.

TABLE 3-3

COMPARISON OF MEASURED AND CALCULATED ANTENNA DATA (Reference 1)

Parameter	Theoretical	Theoretical Calculation	Measured	Comment
Sidelobe	- - -	-23.7 dB	-21.5 dB	Theoretically, aperture blockage of 10 percent causes: <ul style="list-style-type: none"> o Increase of ~3 dB in sidelobe. o Decrease of 0.5 dB in directivity. o Increase in first null position.
Beamwidth	67.03 λ/D	5.67°	6.25°	
First Null Position	85.37 λ/D	7.22°	7.5°	
$\lambda/D = 4.4/52 = 0.0846$				

Reference 1. Hansen, R. C., Microwave Scanning Antennas, Volume I - Apertures, Academic, New York, N. Y., (1964), pp. 64-67.

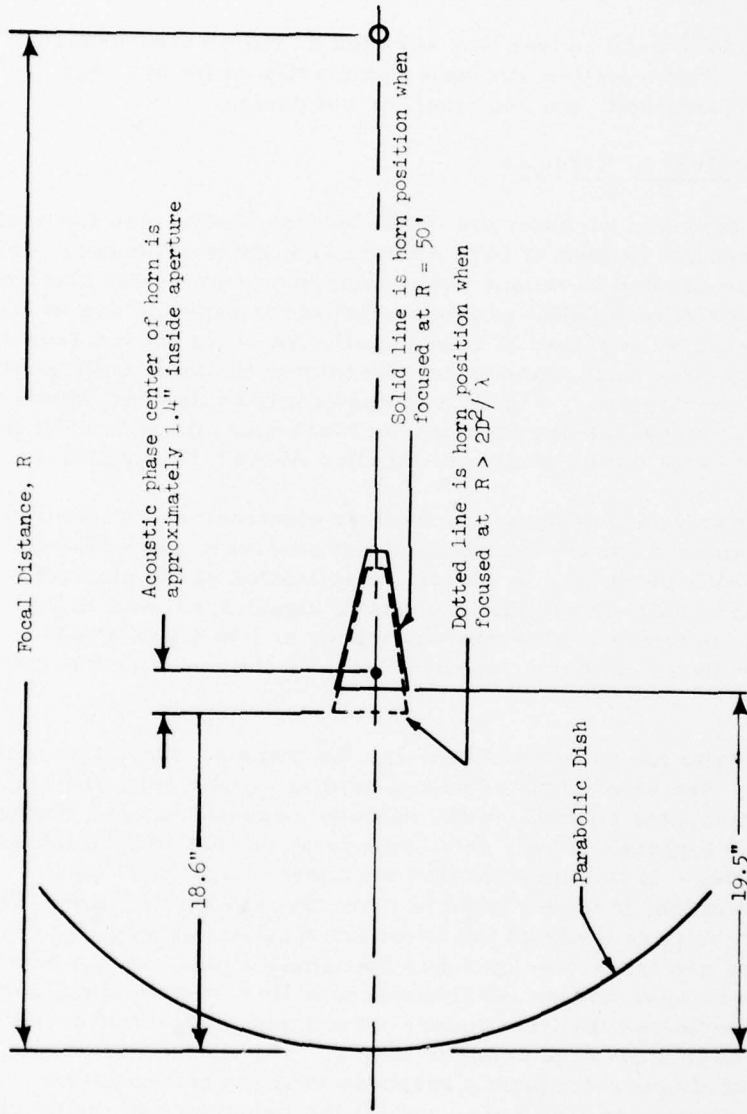

FIGURE 3-8 Sketch Showing Focal Point Relative to Horn Aperture

3.1.1.2.3 Transducer and Associated Electronics

a. Transducer

An Atlas Model PD-60 driver was selected as the electro-acoustic transducer. The selection was based primarily on its low cost, adequate performance, and good mechanical design.

b. Transceiver Electronics

Both the driver and receiver pre-amplification electronics for each array element are located at each electro-acoustic transducer. This approach was adopted to reduce cable costs and to minimize electro-magnetic interference (EMI) problems that accompany the use of long cable runs such as required in field installation of the pulsed acoustic radar subsystem. Each transducer, therefore, contains both transmit and receive electronics. Figure 3-9 shows this equipment, which is part of the acoustic antenna element, in block diagram form. (It is shown in the large dotted enclosure labelled ARRAY ELEMENT.)

The design parameters for the transceiver electronics are listed in Tables 3-4 and 3-5 for the transmitter and receiver, respectively. The transmitter produces, by electrical activation of the electro-acoustic transducer, the required acoustic signal burst of 2 to 5 milliseconds duration at a carrier frequency of 1 to 4 kHz at 100 watts with a maximum burst repetition rate on the order of 3 bursts per second.

The data acquisition subsystem contains the transmit waveform function generators. The waveforms produced by these generators are fed, under minicomputer control, to the selected acoustic antenna elements. The signal is a phase-locked, gated square-wave that is used to drive the transmitter. It is important that the burst should have no DC component and that it should begin in a positive-going direction. This is necessary to permit use of the burst for receiver gating. The input signal drives two transistor switches that apply a plus and a minus 40-volt square wave across the transducer's 16-ohm driver coil. Experience indicates that this square-wave input to the transducer produces a near sine-wave acoustic output. This is the result of: (1) the limited upper-frequency response characteristics of the transducer driver and feed horn, and (2) the inductance of the driver coil.

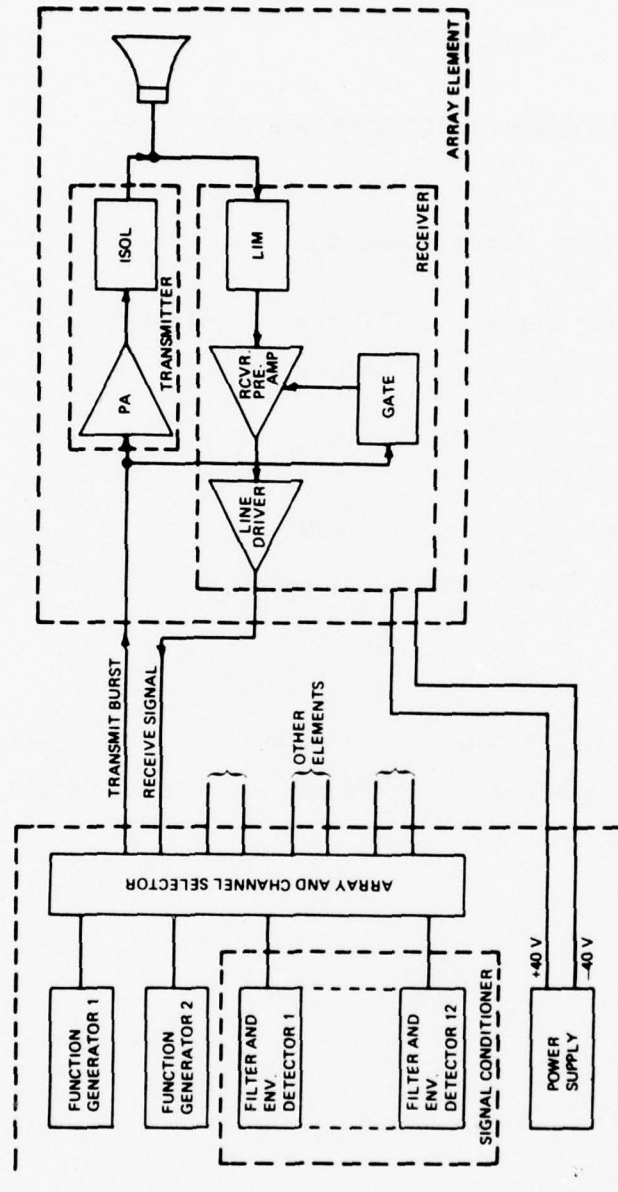

FIGURE 3-9 Block Diagram, Signal Electronics

TABLE 3-4

TRANSMITTER DESIGN PARAMETERS

Transmitter (one per array element)

Peak Power Output	100 watts (electrical)
Input Voltage	<u>+40</u> volts
Input Current	
Quiescent	0.07 amperes
Peak	1 ampere
Operating Frequency	1 to 4 kHz
Pulse	
Duration	2 to 5 milliseconds
Repetition Rate	3 pulses per second, maximum
Output Waveform	Square wave (symmetrical)

TABLE 3-5

RECEIVER DESIGN PARAMETERS

Receiver (one per array element)

Gain	50 dB, maximum
Frequency Range	1 to 4 kHz
Output Swing	10 volts
Gate Control	Gated OFF during transmit period
Input Limiting	± 0.5 volts
Output Impedance	200 ohms

The transmitter power amplifier circuit is shown schematically in Figure 3-10. Due to packaging constraints, the two storage capacitors, C1 and C2, have been located on the receiver circuit board. They provide sufficient storage to minimize the droop in a 5-millisecond burst at a repetition rate of 3 bursts per second. Diodes CR3 and CR4 isolate the driver circuit from the transducer during the receive period.

A gated pre-amplifier is used in the receive portion of the transducer electronics. This prevents damage and overloading of subsequent circuits as a result of the presence of large voltages from the electro-acoustic transducer during and immediately following the transmit pulse. The pre-amplifier supplies 50 dB of gain to produce signal levels on the order of 5 volts. The circuit is shown in schematic diagram form in Figure 3-11. Input protection, provided by R1, CR1, and CR2, limits the +40-volt transmit burst to $\pm 1/2$ volt at the input of the pre-amplifier. A transconductance amplifier, Z1, provides both gate control and signal gain. When the gate (bias) input of Z1 (pin 5) is at -15 volts, the amplifier is OFF since no current flows in the input differential pair. During the CN period the junction of R7 and R8 is raised to the voltage output level for Z2. This value is a function of the peak receiver output. It provides a bias input of about 60 microamperes, maximum, to the pre-amplifier. The 60-microampere value for the bias current was selected to provide 50 dB of pre-amplifier gain. In this circuit amplifier Z2 performs essentially an automatic gain control (AGC) function. Transistors Q1 and Q2 provide low-impedance drive for the output line.

The receiver is gated by using the transmit burst to charge capacitor C6 via diode CR3. Since, as previously noted, the transmit burst always starts from the zero level and with its first excursion positive-going, the capacitor immediately charges, thereby causing the output of the comparator amplifier, Z3, to go into positive saturation. This, in turn, causes amplifier Z2 to go into negative saturation. Diode CR4 allows resistor R8 to pull the gated pre-amplifier bias input to -15 volts, thus cutting off the amplifier.

The transmitter/receiver electronics are installed in the rear of the driver, as shown in Figure 3-12. A rubber O-ring seal provides environmental sealing between the driver housing and the transducer. The feed-through terminals at the bottom of the housing are sealed with a room-temperature vulcanizing (RTV) compound.

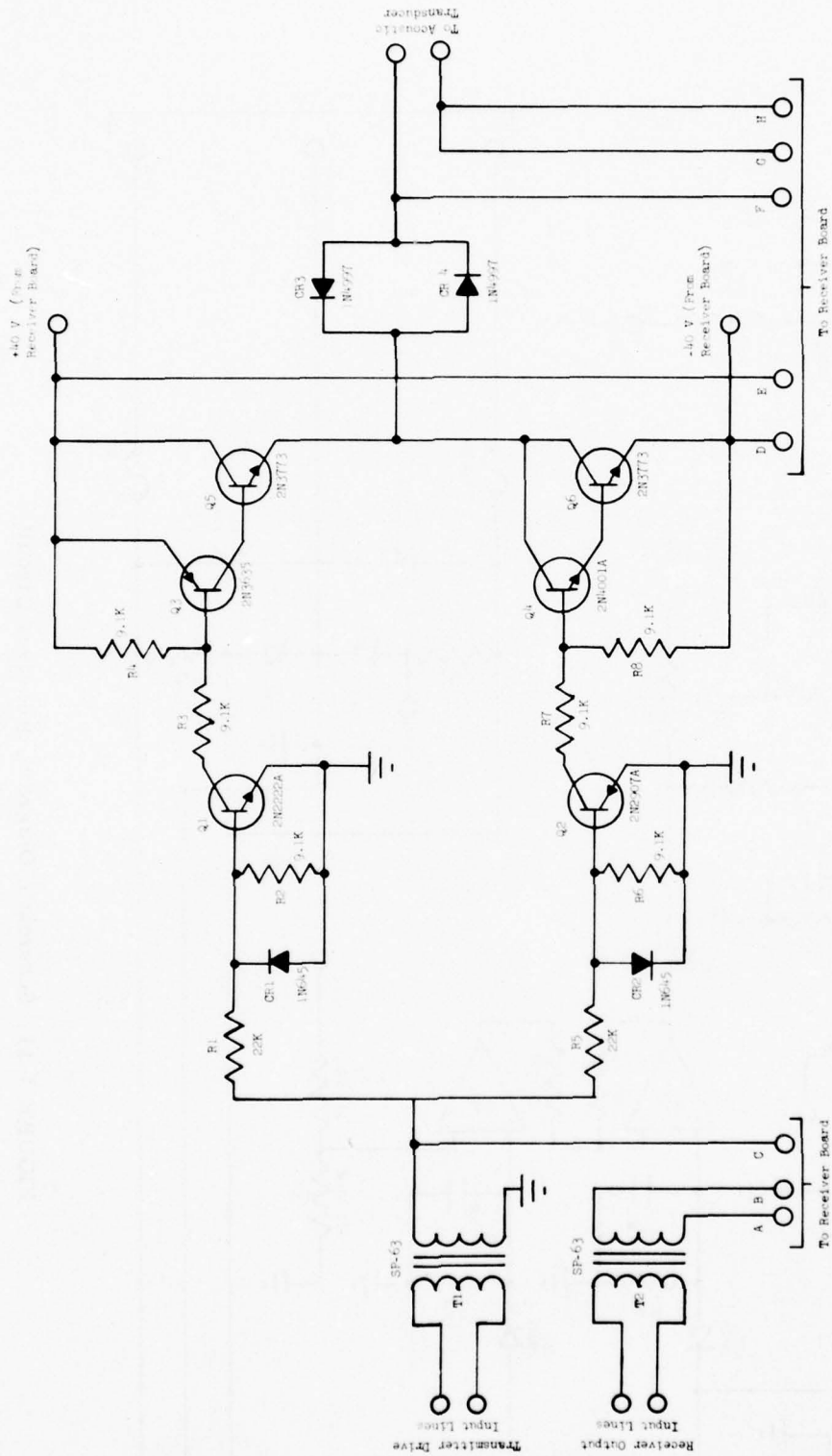

FIGURE 3-10 Schematic Diagram, Transmitter Power Amplifier

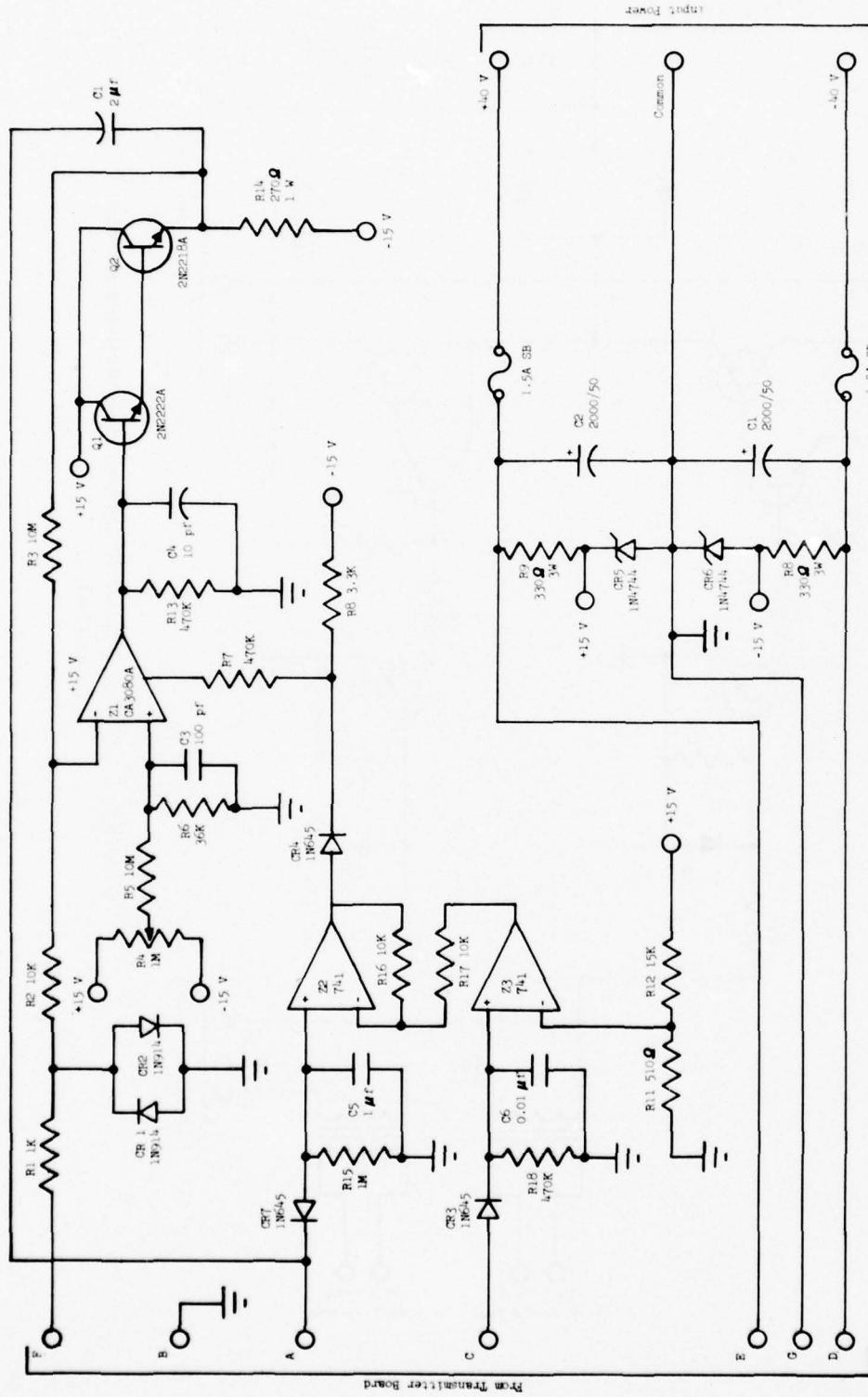

FIGURE 3-11 Schematic Diagram, Receiver Circuit



FIGURE 3-12 Transmit/Receive Electronics Mounted in PD-60

3.1.2 Antenna Support Structure

The antenna support structure, or tower, is shown in Figure 3-13. It provides means for supporting the acoustic antenna element at either of two heights (intermediate--3 to 5 feet, or full--10 feet) above ground level. (The reflector support structure is used, without the tower, in ground level installations.) A guyline and anchoring system is used in the field to stabilize the installation. The antenna support structure is an assembly of two identical symmetrical bents connected by four identical cross braces. Each bent is constructed of 2-inch diameter (nominal), Schedule 80 PVC pipe and fittings. All joints are solvent welded. Each bent is assembled in a fixture used to assure consistency in fabrication, particularly in regard to the dimensions from the bent centerlines to the mounting flanges. The bents are furnished with two sets of mounting flanges--one set for installation of the acoustic antenna element at the intermediate height; the other for its installation at the full height. The braces are made of 1 1/2 -inch by 1 1/2 -inch by 3/16 -inch extruded PVC angle stock. The bents and braces were designed to be symmetrical to avoid need for left-hand and right-hand members. This provided both cost savings and assembly simplicity.

The guyline and anchoring system is designed to prevent lateral or rotational movement of the support structure and to prevent it from toppling over. It includes guylines, anchors, spike angles, and tent pegs.

- a. Guylines (4)--Dacron was selected for the guylines on the basis of its: moderate cost, low stretch, high strength, environmental resistance, flexibility, and ease of tying and untying.
- b. Anchors (4)-The anchors are of commercial design (A. B. Chance, Style 326). In use they are installed about 10 feet away (diagonally) from each corner of the support structure used (reflector or antenna, depending on the installation height desired). Each anchor has a holding power of from 750 to 1000 pounds.

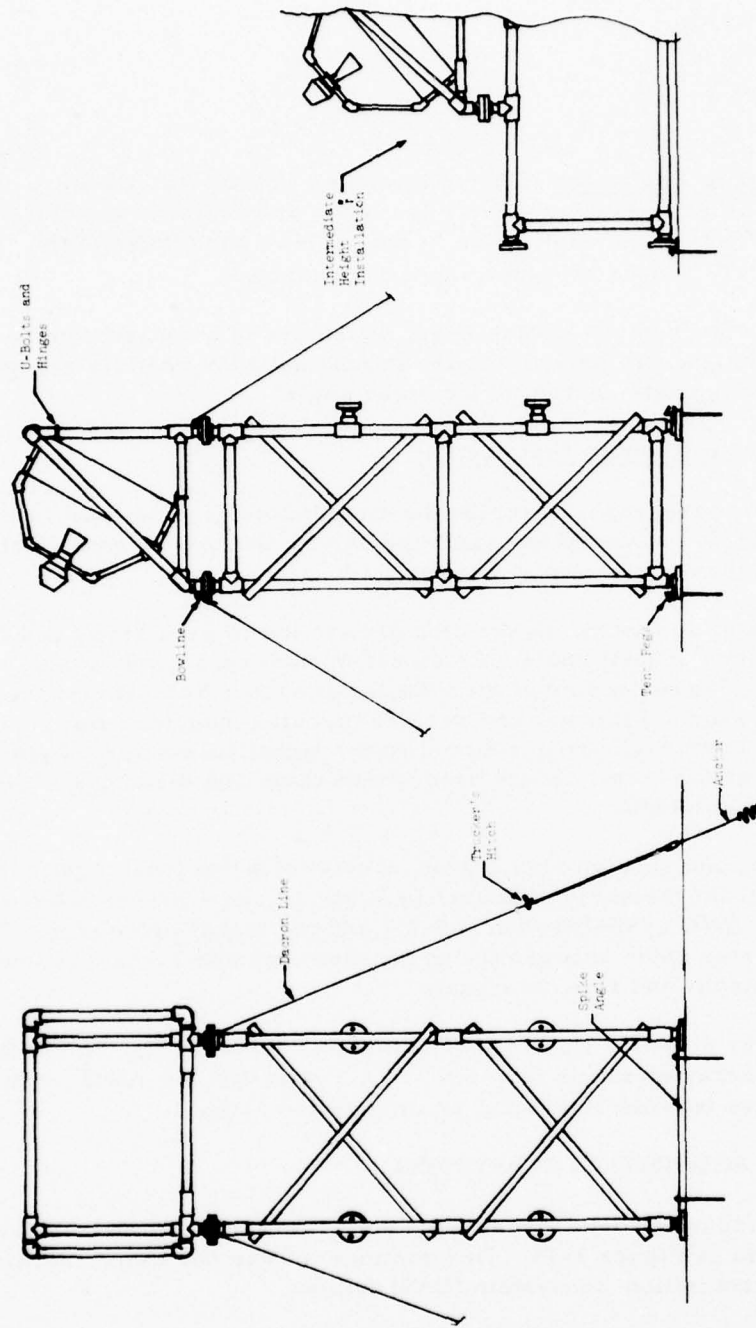

FIGURE 3-13 Complete Tower Assembly

- c. Spike Angles (2)--The spike angles are used at all installation heights. They are made of aluminum structural angle stock. Bolt holes in the angles match holes in the PVC flanges of either support structure.
- d. Tent Pegs (4)--These pegs, which are of standard commercial design, are driven into the ground until they solidly engage the upright portion of the spike angle.

3.1.3. Signal and Power Distribution

The following paragraphs describe the distribution scheme used to route signals and power to and from the driver and transceiver electronics. The cabling layout is shown in Figure 3-14.

For reasons of economy, power circuits are fed to each array and distributed to each acoustic antenna element in each such array via a junction box (J-box) located at the element of each array nearest the signal processor. Transmit and receive circuit conductors run individually from each array element to the signal processor. Appropriate connectors or hard-splices are used where cable run distances exceed available cable lengths.

The transmit and receive signal leads consist of a two twisted pair No. 22 AWG cable from the array elements to J-box 1, and a fifteen twisted pair No. 22 AWG cable between J-box 1 and the signal processor. The two twisted pair cable between the array elements and J-box 1 is used for both transmit and receive signals.

For DC power a 3-wire No. 14 AWG cable and a 3-wire No. 16 AWG cable connect the array elements to J-box 1. A 3-wire No. 14 AWG cable carries power between the signal processor and J-box 1.

3.2 DATA ACQUISITION SUBSYSTEM

The pulsed acoustic vortex sensing system (PAVSS) is shown in block diagram form in Figure 3-15. Descriptions of various items included in the data acquisition subsystem (DAS) follow.

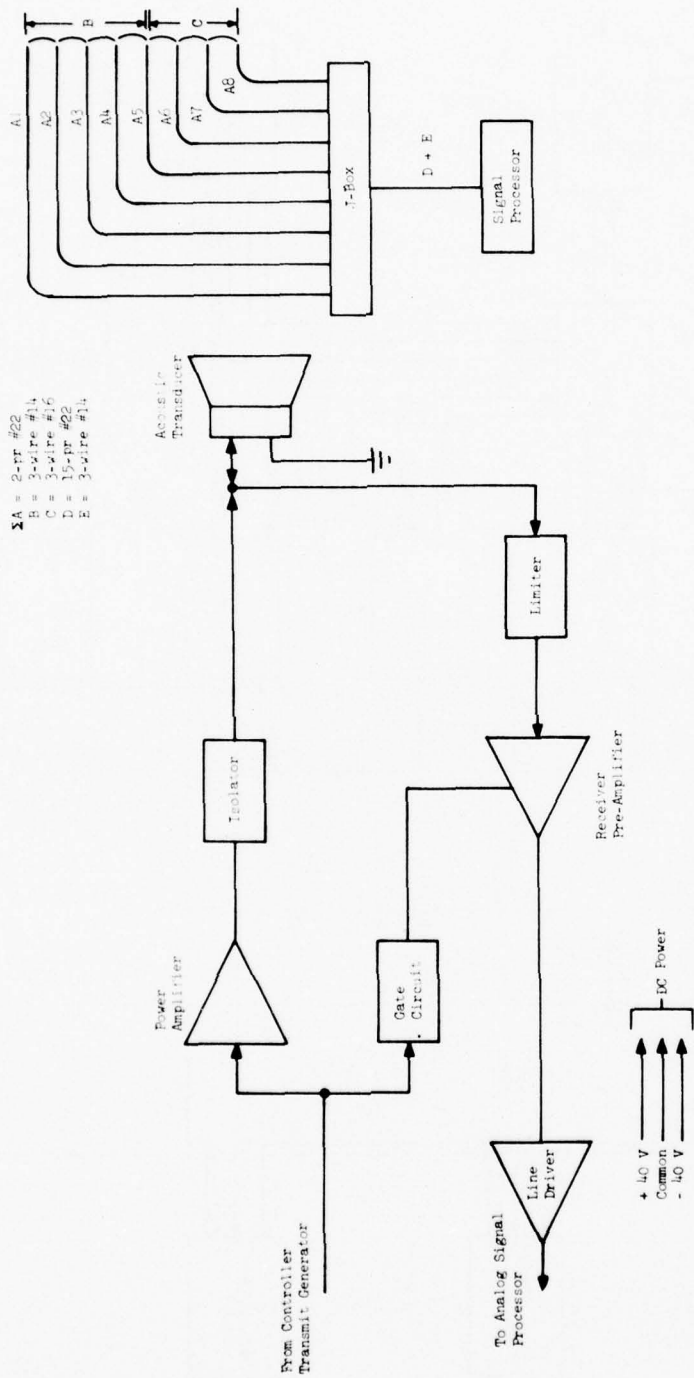

FIGURE 3-14 Cabling and Signal Flow Diagram

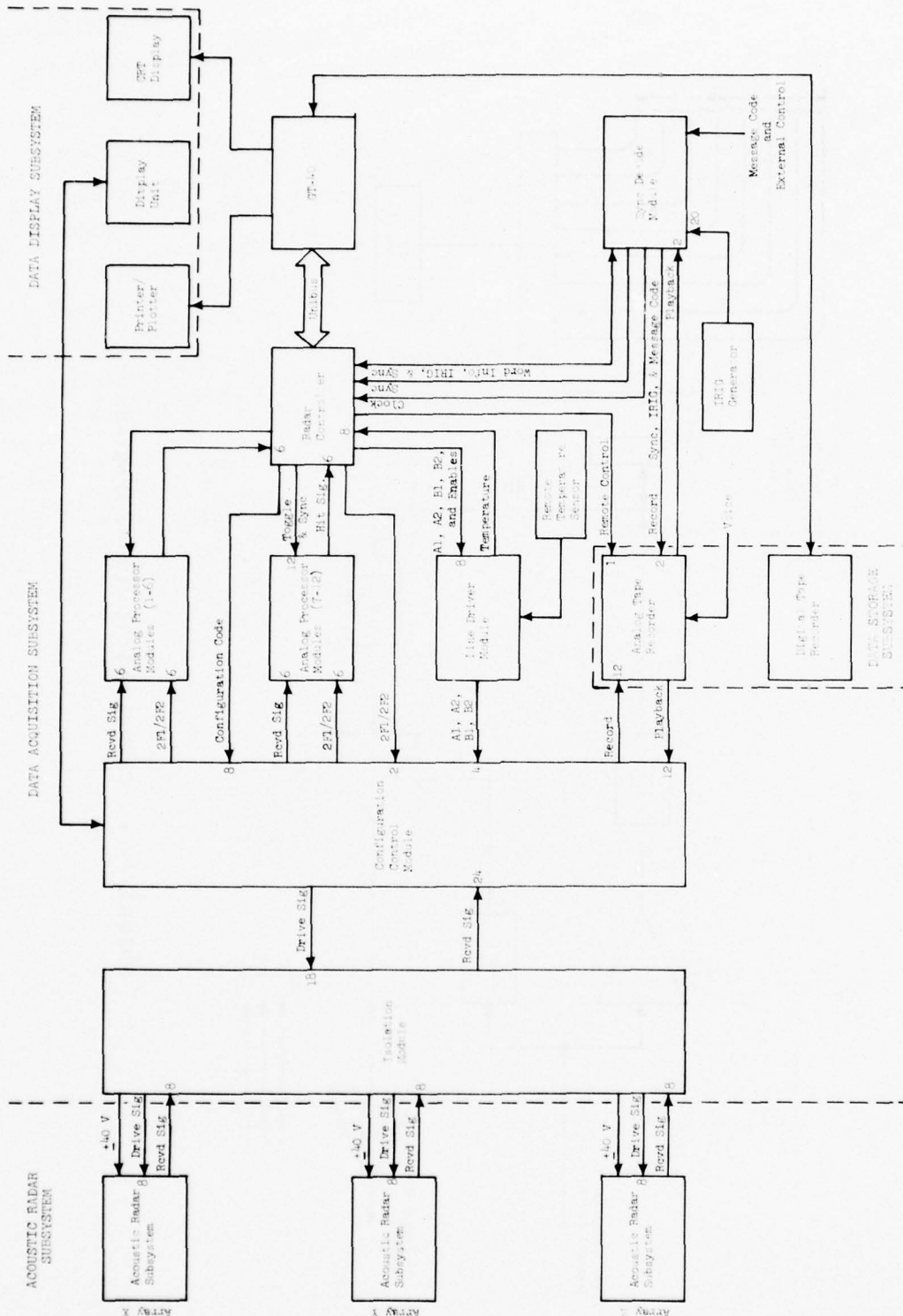

FIGURE 3-15 Block Diagram, Pulsed Acoustic Vortex Sensing System

3.2.1 Isolation Module

The isolation module provides galvanic isolation between the data acquisition equipment and the cables to the pulsed acoustic radar subsystem's three arrays. It also protects the signal processing equipment from over-voltage surges originating in the external cabling.

The incoming signal is pre-filtered through a passive high-pass filter to eliminate high-amplitude, low-frequency noise that might saturate the active components in the signal processing chain. The cutoff frequency of this filter is set low enough (800 Hz), however, to assure that the lowest frequency signal (1000 Hz) can pass through without attenuation.

The basic circuit of this module is shown in schematic diagram form in Figure 3-16.

3.2.2 Configuration Control Module

The configuration control module contains the switching matrix and associated control circuits used to interconnect the inputs and outputs of the data processing circuits, the analog tape unit, and the three pulsed acoustic radar arrays (X, Y, and Z on Figure 2-1). The system configuration is represented by an 8-digit code. Code assignments are defined in Figure 3-17.

The subsystem controller generates 2 independently programmable frames--A and B (frame period and pulse length). These frames can be modulated onto 2 independently selectable carrier frequencies--F1 and F2.

Bits 0 and 1 of the configuration control code select the application of frames A and B to 2 out of the 3 arrays (X, Y, and Z). If bits 0 and 1 are both ZERO, the play-back mode is selected and all arrays are disconnected.

Bits 2 and 3 of the configuration control code serve to interchange the carrier frequencies between the two sides of the selected arrays.

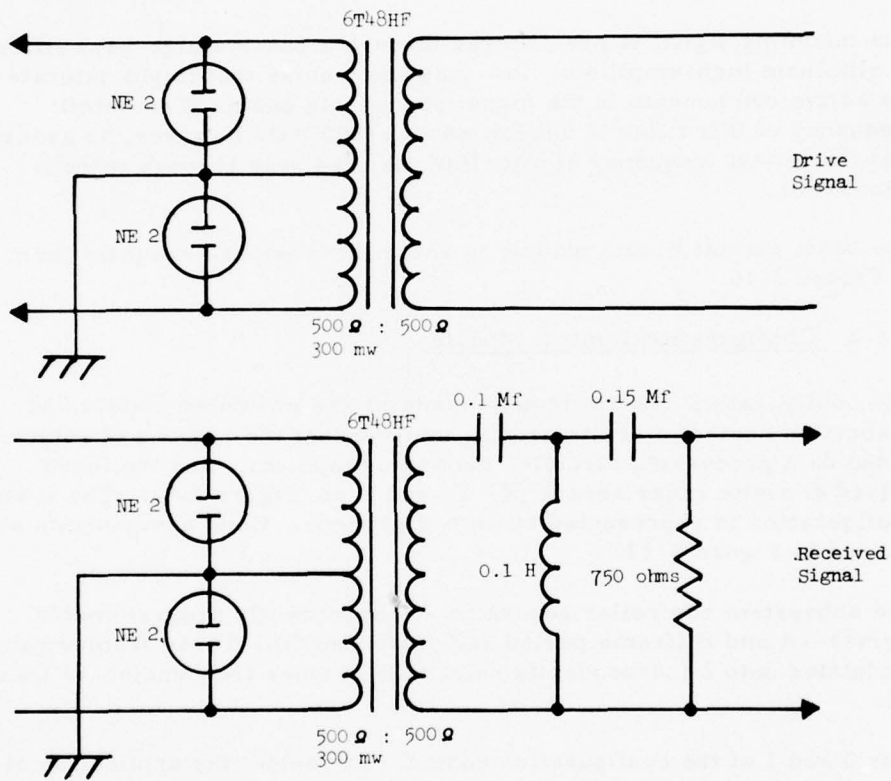

FIGURE 3-16 Schematic Diagram, Isolation Module

8-BIT CODE

Bit 1	Bit 2	Frame A Goes to	Frame B Goes to
0	0	N.C.*	N.C.*
0	1	X	Y
1	0	Y	Z
1	1	X	Z

* Playback Mode, all arrays are disconnected.

Bit 2 (Frame A) Bit 3 (Frame B)	Carrier Frequency Left	Carrier Frequency Right
0	F1	F2
1	F2	F1

Bit 4 (Frame A, left) Bit 5 (Frame A, right) Bit 6 (Frame B, left) Bit 7 (Frame B, right)	Optional Transducer Selected
0	Outer
1	Inner

FIGURE 3-17 Configuration Control Scheme

The remaining 4 bits (4, 5, 6, and 7) select one of the two optional transducers in each half-array.

The identity of the arrays that are active and of the elements that are being used can be displayed (via the display subsystem). The operator can then use the information displayed for making appropriate voice inputs to the analog magnetic tape recorder.

For a schematic diagram of the configuration control module, see Figure 3-18 (Parts A, B, and C).

3.2.3 Line Driver Module

The line driver module raises the transducer excitation signals to a level adequate to drive up to 5,000 feet of cabling. This module is shown schematically in Figure 3-19. Inputs to the line driver module are: (1) square-wave carrier frequencies F1 and F2, and (2) the synchronized pulse envelopes for frames A or B. A high-power operational amplifier controlled by analog switches combines the inputs to generate an output signal. The output signal is produced in the form shown in Figure 3-19. Four identical channels are provided. These cover all combinations of frames A and B and frequencies F1 and F2.

The line driver module also includes an 8-bit analog-to-digital (A/D) converter used to permit accurate recording of the temperature environment during data collection. The 0 to 5-volt output of the remote temperature sensor is converted to an appropriate 8-bit digital output which, in turn, is entered in the temperature register in the radar controller.

3.2.4 Analog Processor Modules

Twelve analog processor modules are used. Inputs to these modules are the return signals from the acoustic transducers in the pulsed acoustic radar subsystem. After these input signals are filtered and detected the module generates an event, or hit, pulse whenever the conditioned signal exceeds the magnitude of a pre-set threshold. Figure 3-20 is a block diagram of the analog processor module. After pre-filtering of the input signal (from the pulsed acoustic radar subsystem) by the isolation module, as noted above, the signal passes through a synchronous detector that acts as both a narrow-band filter and a detector. For a block diagram of the synchronous detector, see Figure 3-21. The detected

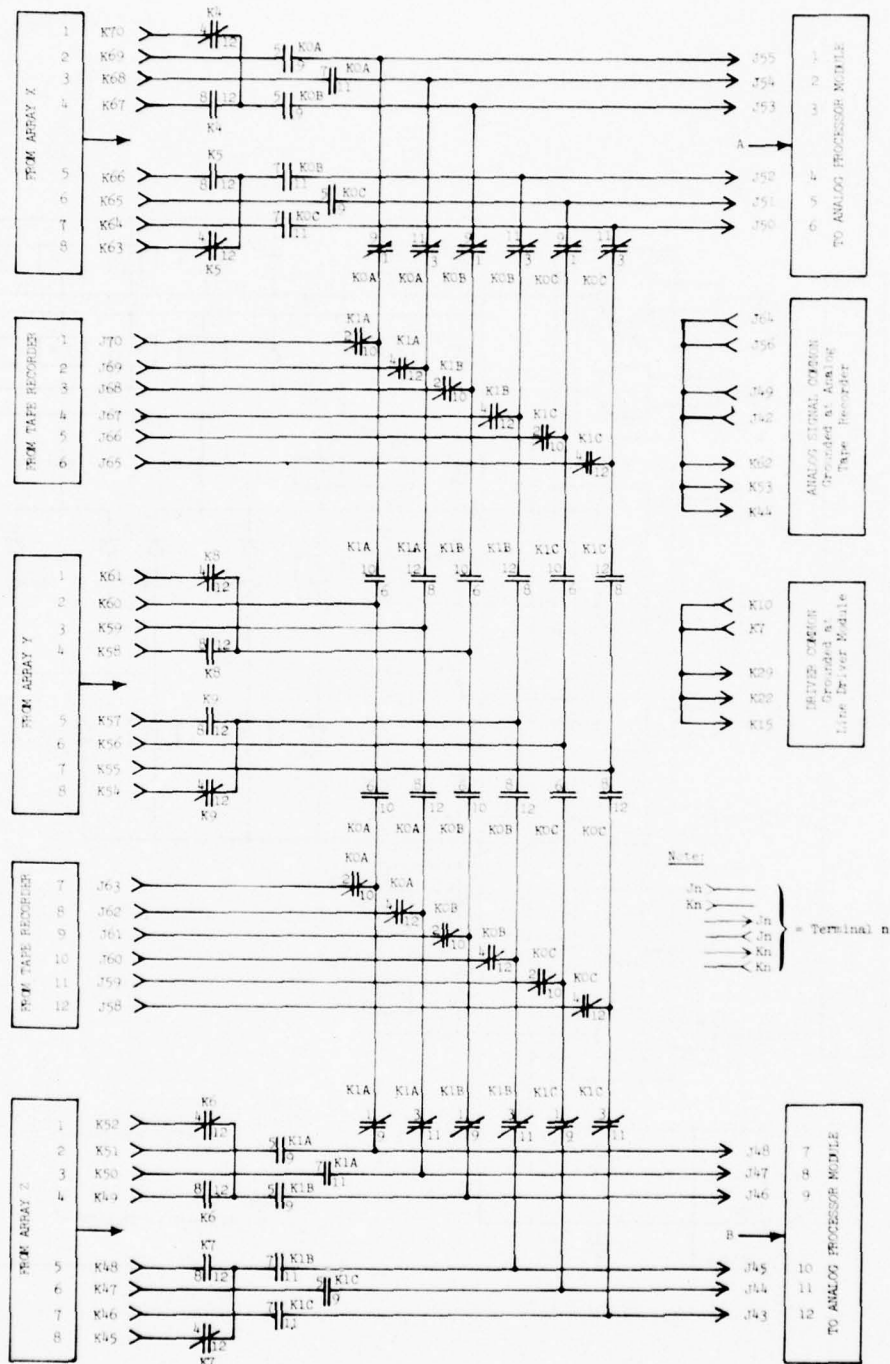

FIGURE 3-18A Block Diagram, Configuration Control Module, Sheet 1

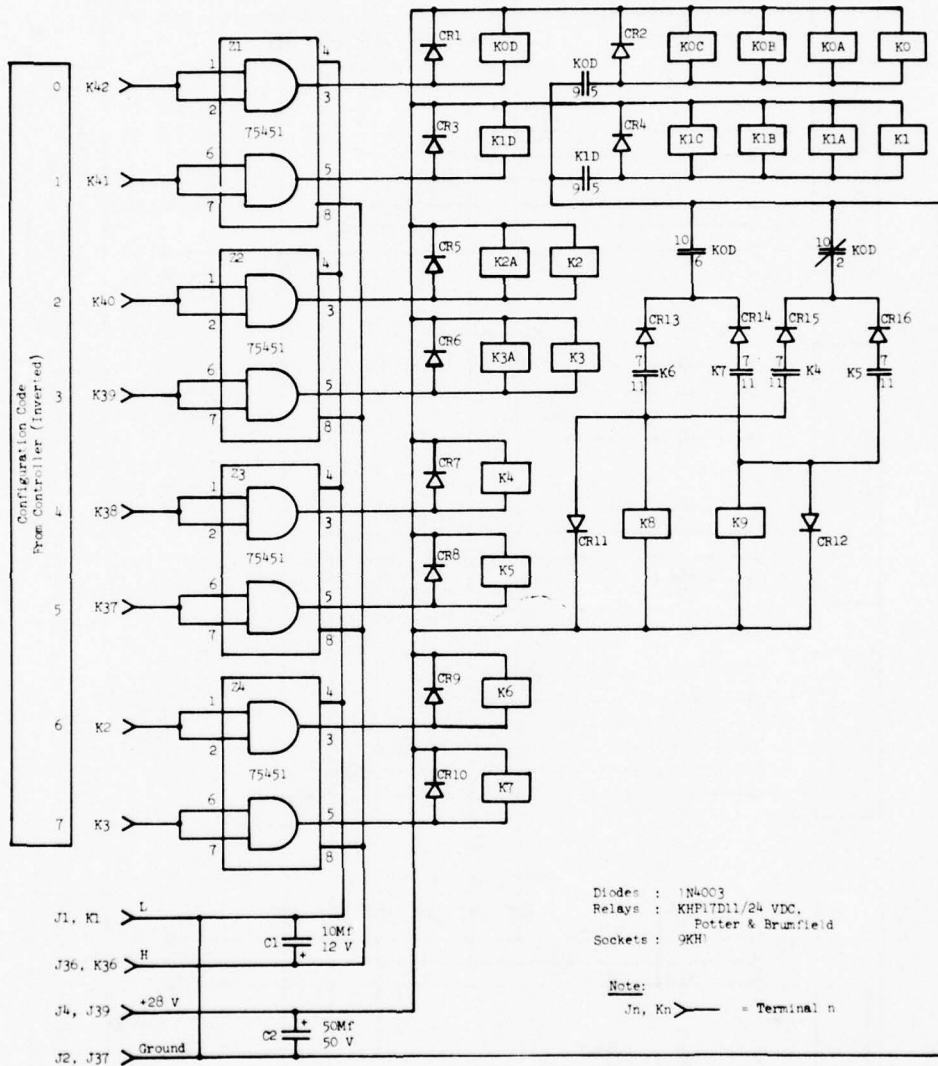

FIGURE 3-18B Block Diagram, Configuration Control Module, Sheet 2

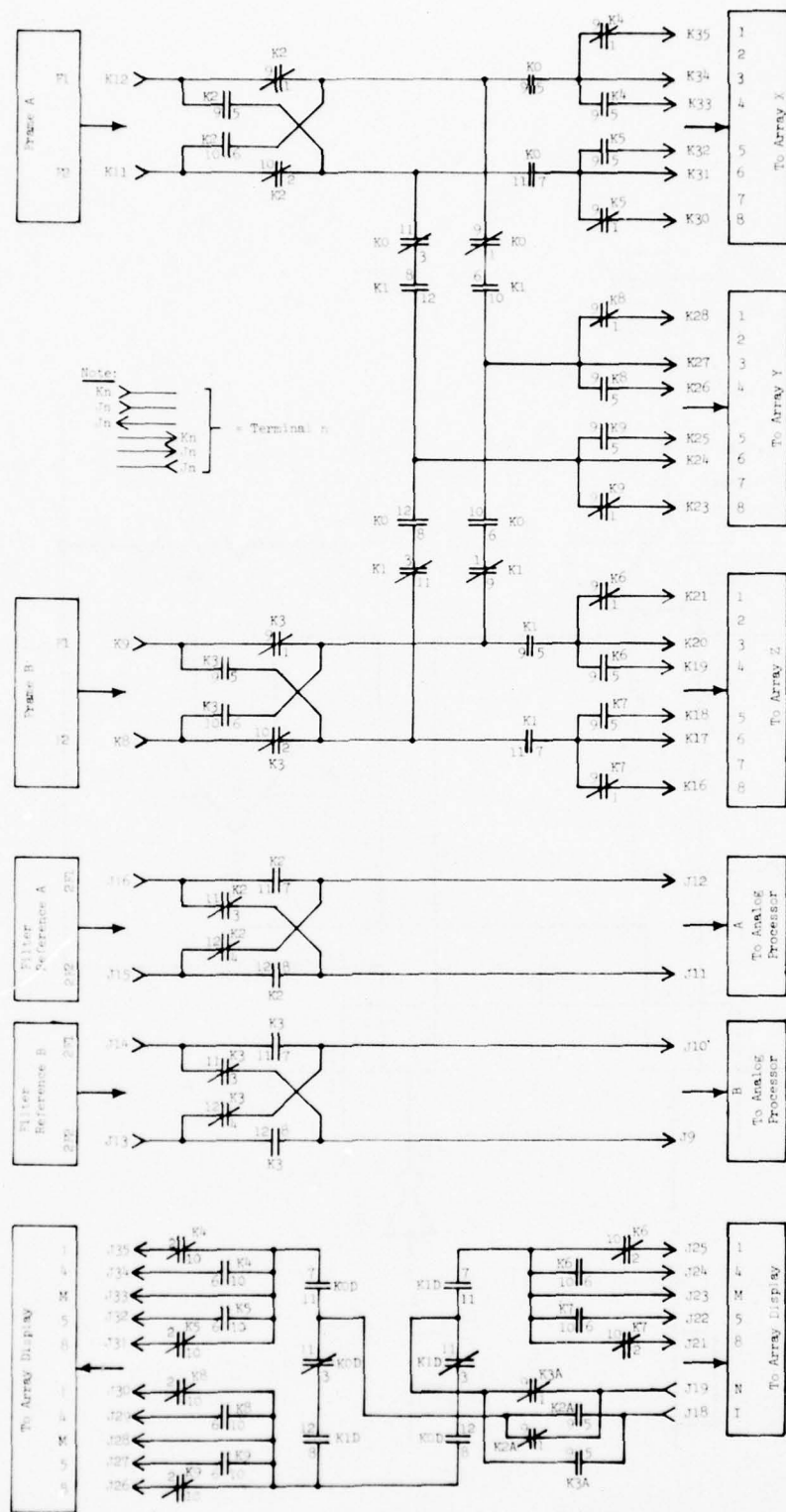

FIGURE 3-18C Block Diagram, Configuration Control Module, Sheet 3

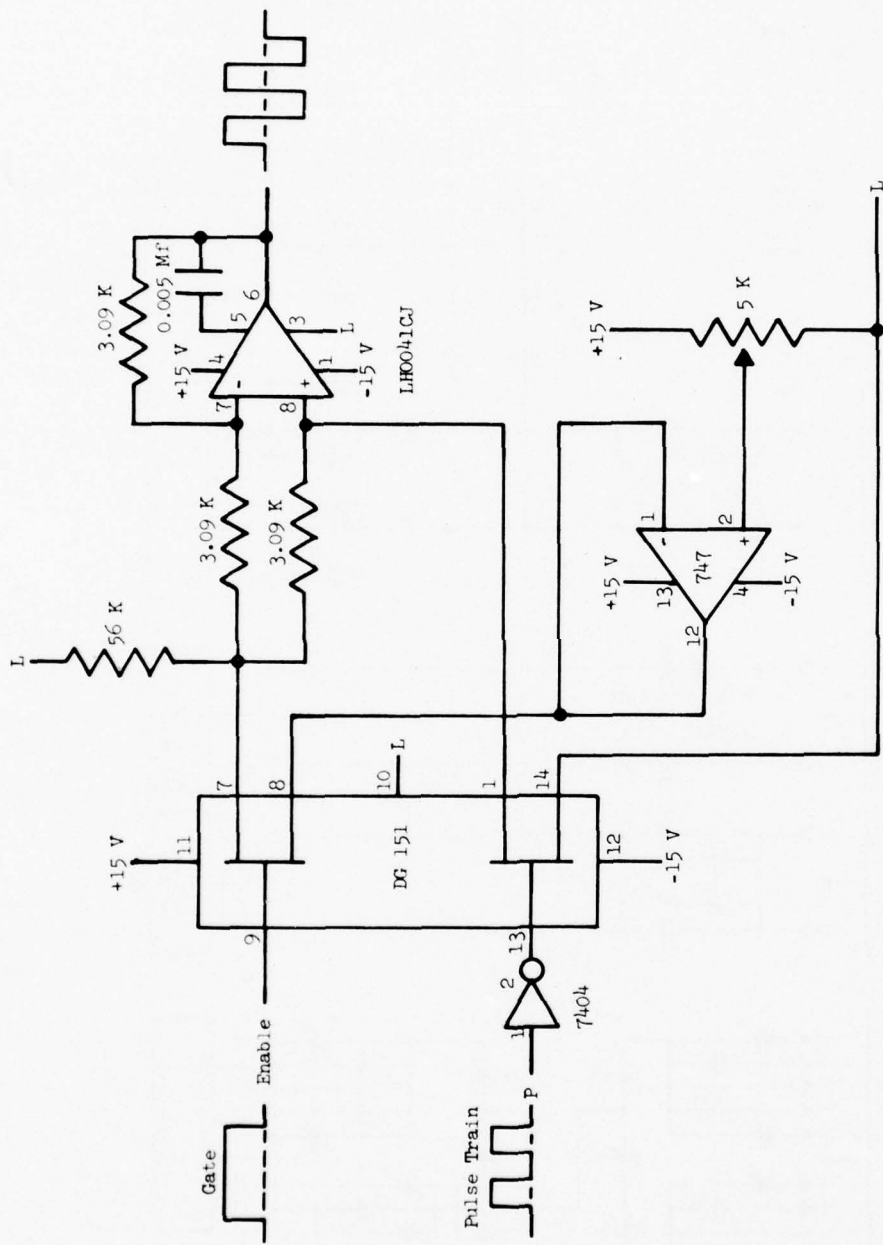

FIGURE 3-19 Schematic Diagram, Line Driver Module

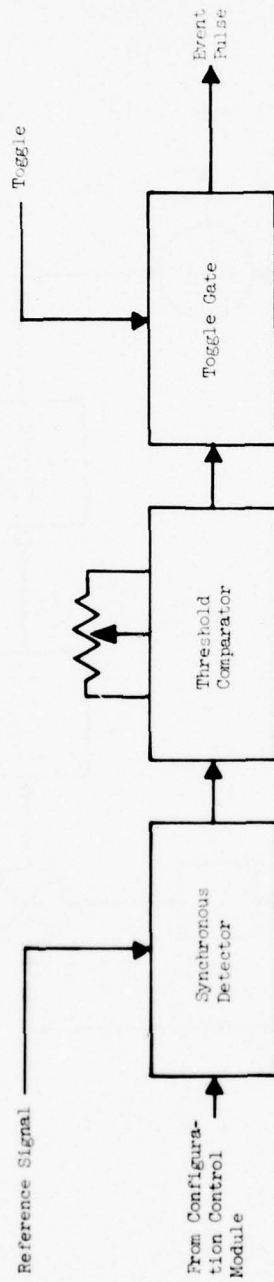

FIGURE 3-20 Block Diagram, Analog Processor Module

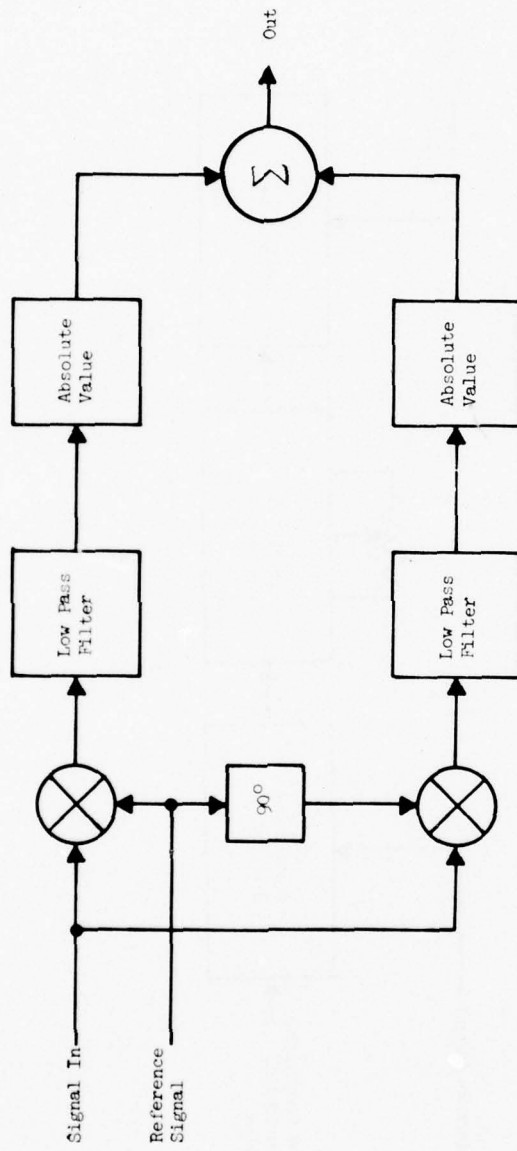

FIGURE 3-21 Block Diagram, Synchronous Detector

signal is then multiplied by the reference signal--which is a square wave signal at the frequency of the carrier. If the signal is phase coherent with the reference signal a DC component will be present at the output of the multiplier. The magnitude of this component is proportional to the cosine of the phase difference between the signal and the reference signal. To avoid phase-dependence in the output, two channels are used with the reference signal on one channel 90° out of phase with the reference signal on the other channel. After the signal is filtered the absolute values of the multiplier outputs are added. The resulting signal is unipolar and has a maximum variation of 3 dB. The actual value of the variation is a function of the signal phase.

Figure 3-22 shows the transfer characteristics of the synchronous detector/filter for a reference frequency of 3 kHz. Some response occurs at the odd harmonics of the reference frequency due to its square-wave shape. This is not serious because the carrier harmonics are effectively reduced in the transmitter and acoustic propagation path. The choice of a synchronous detector approach was favored since it avoids the center frequency and bandwidth control difficulties associated with the use of resistance-controlled filters. The detected signal next enters the threshold comparator circuit shown schematically in Figure 3-23. There the signal is first buffered by operational amplifier 1 and then twice differentiated in dual operational amplifier 2. When the negative of the first derivative (on pin 12 of operational amplifier 2) becomes more negative than the pre-set threshold voltage on pin 3 of comparator 6, the comparator produces an output signal. This indicates that the rate of rise of the input signal has exceeded the set rate. When the second derivative (on pin 10 of operational amplifier 2) goes from positive through ZERO to negative, the zero-crossing comparator (comparator 5) produces an output signal. This latter signal triggers monostable multivibrator 10 whose output goes positive for a period whose length is determined by the values of C3 and R7. The noise sensitivity of comparator 5 is reduced by hysteresis introduced by R6 and R4. When both comparators (5 and 6) produce output signals simultaneously monostable multivibrator 11 produces a uniform output "hit" pulse.

A toggle gate is incorporated in the analog processor module to exclude signals from unwanted events. The gate is reset to the closed state by the frame sync pulse. Subsequently it toggles with each toggle pulse received from the controller. Thus any portion of the frame can be masked out as desired.

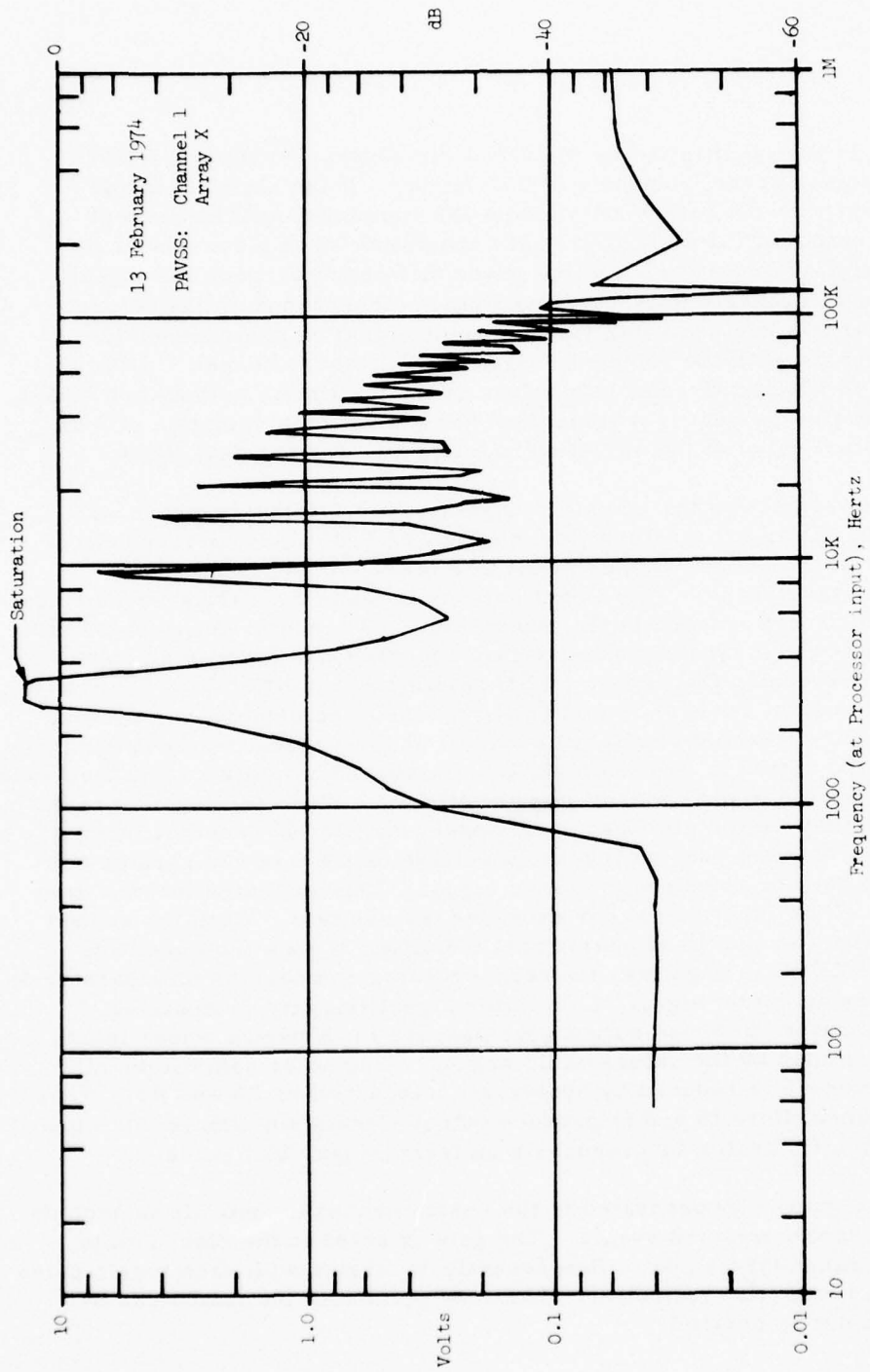

FIGURE 3-22 Synchronous Detector Transfer Characteristics
at 3 kHz

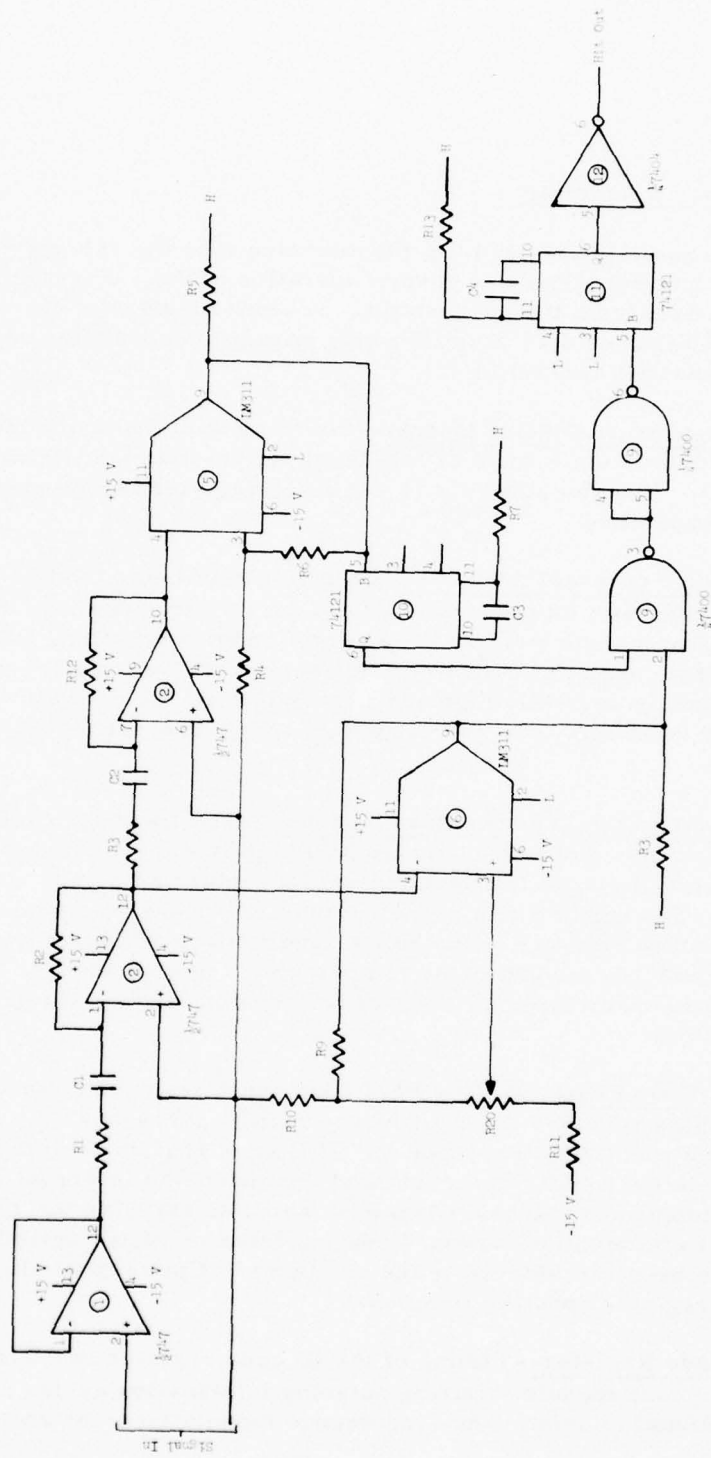

FIGURE 3-23 Maximum Rate Threshold Detector

3.2.5 Radar Controller

The radar controller is used to: (1) interface with the various subsystems, (2) provide control signals to govern operation of the subsystems, and (3) receive data from the subsystems. A block diagram of the controller is shown in Figure 3-24. The following paragraphs describe various items in the radar controller.

a. Configuration Control Module--Interface with the configuration control module is via 8 lines of low-level active-state transistor-transistor logic (TTL). The register is a 16-bit write register (which provides 8-bit expansion capability).

b. Analog Processor Module--The analog processor module interfaces are as follows: two lines for each of the carrier frequencies, one line to each analog processor module for a toggle command, and an event pulse input line from each of the analog processor modules. Each toggle command line is normally high and it goes low for the activate state. The event pulse input lines are normally high and go low during the event pulses.

c. Message Code/Temperature Register--The message code temperature register interface consists of 8 normally high lines. If any line goes low, the register will strobe the data and send an interrupt signal to the minicomputer. The upper 8 bits of the register are used for the message code; the temperature register occupies the lower 8 bits of the register. On command from the computer the temperature register accepts digital data from the temperature sensor A/D converter and strobes the data to the minicomputer.

d. IRIG Code Register--The IRIG code register is a constantly updated register which receives its input from the IRIG generator. Upon receipt of a start-of-run (SOR) command the IRIG code register completes any updating if in the middle of a cycle and then sends an interrupt command to the minicomputer. It takes two data words to transfer the 17 bits of the time code to the minicomputer. Updating remains halted until the two data words have been transferred to the computer. Upon completion of the transfer, register updating resumes.

e. ID Code Register--Timing of the ID code register is controlled by the sync code module. During outgoing information cycles a data available signal is sent. The sync decode module then controls the data

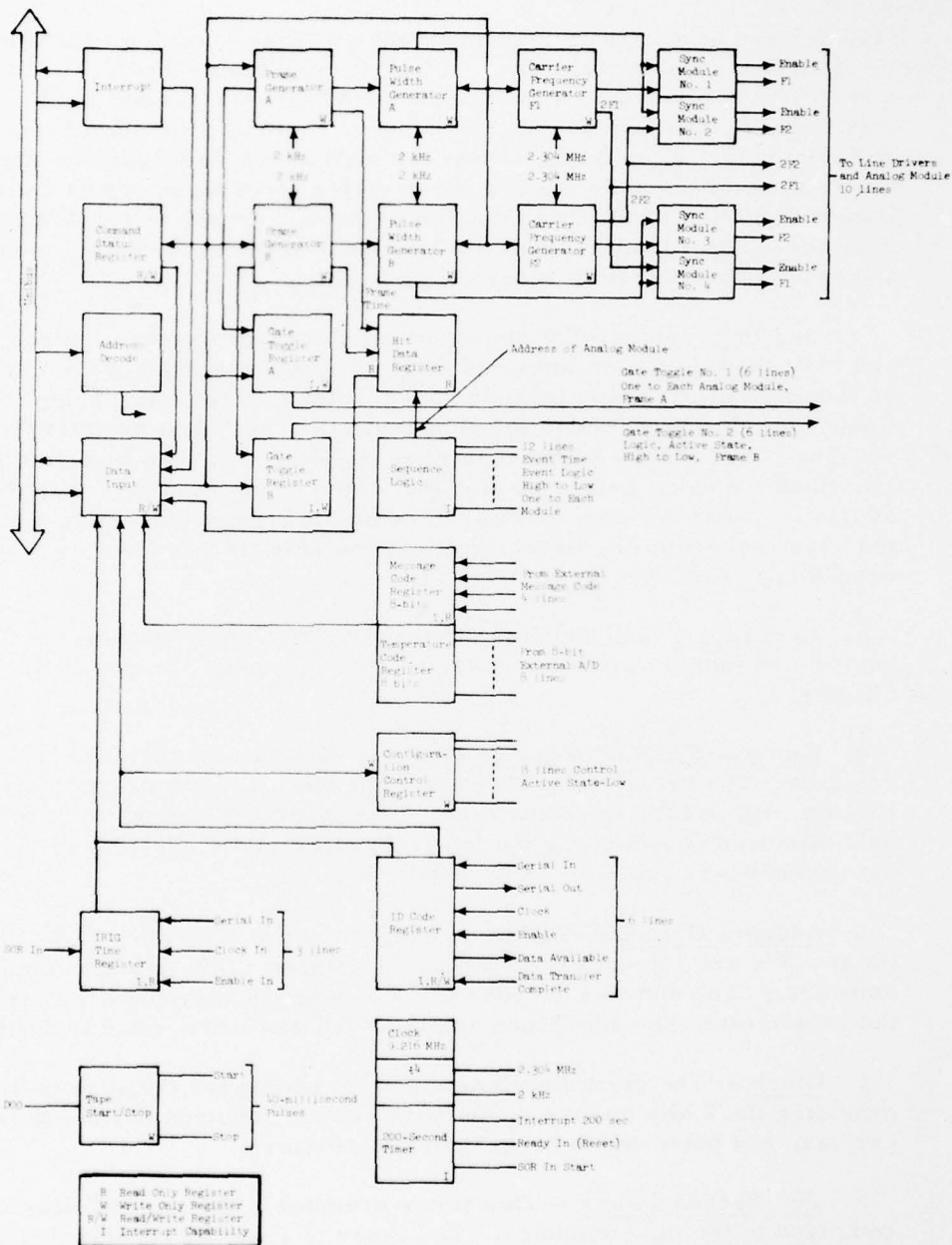

FIGURE 3-24 Block Diagram, Radar Controller

transfer and sends a data transfer complete signal upon completion of the transfer. A controller busy signal is used during the active data transfer to prevent data from being entered into the register while data is being transferred out. The data in cycle is controlled by a suitable interrupt command. Upon completion of a data transfer from the sync decode module the ID code register sends an interrupt command. Upon completion of the data transfer to the minicomputer the ID code register sends a READY-FOR-DATA signal to the sync control module to signal its readiness to receive data again.

f. Sequence Logic -- The sequence logic accepts the event pulses and uses them to set an interrupt flag. At the same it places a hold on the appropriate frame register associated with the event pulse. Upon command from the minicomputer to the "hit" data register, the sequence logic enters on the data lines the address of the module that contained the event pulse and also the frame time associated with that address. When the data transfer is completed the sequence logic clears the event interrupt flag associated with the data transfer and then searches sequentially for a new event flag.

g. Interrupt -- This consists of standard DEC interrupt circuits. The one vector address provided is selectable via a plug-in component adapter.

h. Command Status Register (CSR) -- The CSR is a 16-bit read/write register. The lower-order bits are write-only bits used to activate various registers in the controller. The upper-order 8 bits are read-only bits used in indicating the interrupt mode of the system. Bit assignments are listed in Table 3-6.

i. Address Decode -- The basic address of the controller is 77XX where the two X's are selectable via a plug-in adapter. (XX is 64 for the PAVSS software.) The address decoder decodes up to 16 addresses for use with the controller. The addresses and their functions are listed in Table 3-7.

j. Clock -- The clock provides the basic timing for the system by providing the 2 kHz and the 2.304 MHz signals required to time the frame, carrier, and pulse-width programmable counters.

k. 200-Second Timer -- This timer provides a 200-second interrupt command to the minicomputer. The timer is reset by receipt of the READY command and started upon receipt of an SOR command.

TABLE 3-6

COMMAND STATUS REGISTER FUNCTIONS

<u>Bit</u>	<u>Functions</u>
15	Hit Data
14	Time - Start-of-Run (SOR)
13	Gate Toggle Mark No. 2
12	Gate Toggle Mark No. 1
11	Ready Signal
10	Start-of-Run Identification (SOR - ID)
9	Run Time Out
8	Message Call
7	Done
6	Interrupt Enable
5	Busy
4	200-Second Timer Enable
3	Toggle Enable
2	ID Code Enable
1	Playback Enable
0	Enable

TABLE 3-7
ADDRESS LIST

<u>Address</u>	<u>Function</u>	<u>Read/Write</u>
00	Command Status Register	R/W
02	Hit Data	R
04	Frame Period 1	W
06	Frame Period 2	W
10	Carrier and Pulse Length 1	W
12	Carrier and Pulse Length 2	W
14	Gate Toggle 1	W
16	Gate Toggle 2	W
20	Configuration Control	W
22	Identification (ID) Code	R/W
24	Message Code/Temperature	R
26	Tape Start/Stop	W
30	IRIG Time - SOR	R
32	Spare	
34	Spare	
36	Spare	

l. Gate Toggle Register--Two such registers are required. A code is entered in the register along with the lower-order 10 bits of the data to provide the time required for the toggle command (in one-millisecond increments). The value thus entered is then compared with the value represented by the upper-order 10 bits of the frame generator. When the times match, the register sends a pulse to the analog processor modules designated by the contents of the upper-order 6 bits of the gate toggle register.

m. Frame Generator--Two frame generators are used. Each frame generator is controlled by a 12-bit code provided by the minicomputer. The code from the minicomputer is compared with the contents of a counter. When these match, the frame generator produces a signal to activate the pulse width generator and also resets the counter for a new cycle. The frame generator is clocked by a 4 kHz signal. In the approach used a 0.5 millisecond resolution is obtained for the frame period. The maximum frame period is 2.0415 seconds.

n. Pulse Width Generator-- Two pulse width generators are used in the radar controller. The pulse width generator is set by the upper-order 6 bits of the word used to set the carrier frequency and the pulse width generator. The pulse width generator is clocked by a 1 kHz generator. The resultant maximum pulse length is 63 milliseconds. The pulse width generator sends an enable pulse to the sync module when activated by the frame period generator. The enable pulse is maintained for the duration of the pulse period.

o. Carrier Frequency Generator -- two carrier frequency generators are required. The carrier frequency is generated by programmable counters controlled by a 10-bit code. The code value is 4 times the required carrier frequency. The output of the programmable counter is divided by 2 to provide a $2F$ output square wave that serves as a reference signal for the analog processor module. The $2F$ output is then divided by 2 in the sync module to provide the proper frequency signal to the driver modules. The frequency range is from 576 kHz ($2.304 \text{ MHz}/4$) to 563 Hz ($2.304 \text{ MHz}/4092$). The frequency, F , is $2.304 \text{ MHz}/4n$, where n is any integer from 1 to 1023.

p. Sync Module--Four sync modules are used to provide the required control logic for the four line drivers. The sync modules are enabled by the pulse width generators (two to each generator) and provide the enable

signals and the sync frequency for the line drivers. The output of the sync modules always begins with a positive-going pulse and ends with a negative-going pulse. Only full cycles are provided to the line drivers.

q. Tape Stop/Start-- The tape stop/start commands are provided by addressing the tape start/stop register. If a ONE is set into the DOO bit, the tape will start. It will stop in response to a ZERO in the DOO bit. The tape will also stop in response to an initiate signal to the controller.

3.2.6 Sync Decode Module

The sync decode module is packaged on two circuit boards. One board contains the analog and filter circuits for the analog tape recorder; the other provides circuits for the digital interface with the controller, digital decoding, and coding of the analog signals. Figure 3-25 is a block diagram of the sync decode module.

a. IRIG Time Generator Interface-- The IRIG time generator interface is handled by a parallel-to-serial converter. The parallel register is loaded whenever the lowest-order bit (1-second increments, in effect) of the register changes state. A delay is then triggered to allow the data to stabilize, and then the parallel register contents are transferred serially to the radar controller at a transfer rate of 144 kHz. The register can accept up to 20 bits of information in parallel.

b. Word Information Network-- When the data available signal is activated the word code register first inhibits the sync I signal. It then sends out a 15-bit, 8-kHz start-of-word signal. This is followed by 8 kHz bursts of pulses for ONES or ZEROES. These are sent at a rate of 250 Hz. Eight pulses are sent out for a ONE; four pulses are sent out for a ZERO. The register also clocks the primary controller and when the 16-bit word is complete it sends out a data transfer complete signal. (Figure 3-26 indicates the configuration used for data transfer.) The data out signal is OR'd with the sync I signal and sent to a conditioning operational amplifier used to enter the information on the magnetic tape.

c. IRIG In-- The IRIG input is first filtered by a low-pass filter and then summed with the sync II signal in a summing amplifier used to condition the signal for subsequent recording on magnetic tape. This configuration requires use of an IRIG format B signal with a 1 kHz carrier.

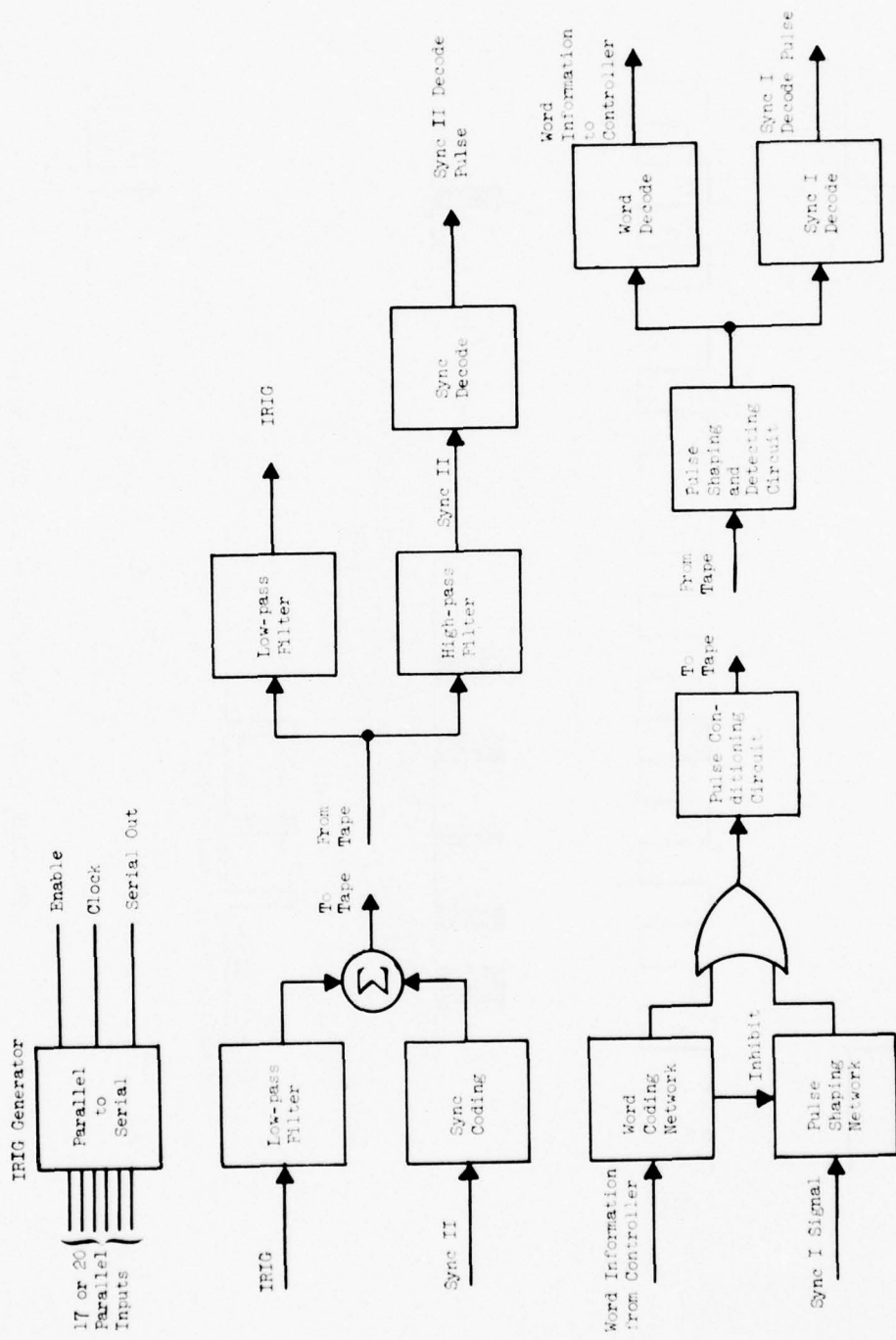

FIGURE 3-25 Sync Decoder Module

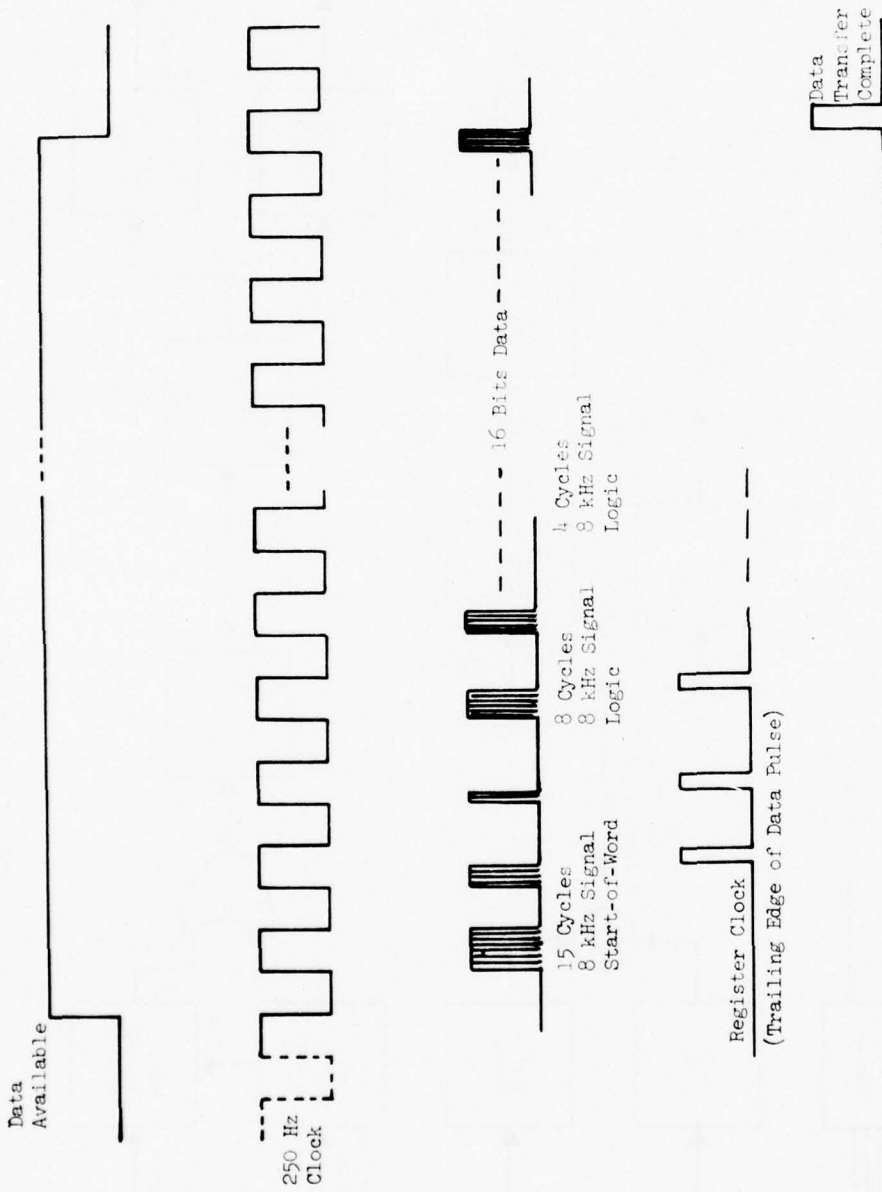

FIGURE 3-26 Data Transfer Configuration

d. IRIG and Sync II Decode -- The signal from the magnetic tape is routed in parallel through low- and high-pass filters. These are used to separate the IRIG and sync signals. The IRIG signal is then available for subsequent decoding (by an external decoder that is not included in the PAVSS design). The sync II signal is then applied to an amplitude detector used to provide the sync II output command (sync II decode pulse).

e. Word and Sync I Decode -- The information from the tape recorder is passed through an amplitude detector to detect the 8 kHz pulses. A word decode module counts the number of bits in the word. If more than 12 are decoded, the register begins to send the data to the radar controller. All transfer timing is accomplished in response to the information acquired by decoding of the ONES and ZEROES. The sync I decoder sends out a pulse at the start of every word whose information content is to be disregarded (those words that do not contain data, for example). Provision has been made for synchronizing word transfer with the frame sync signals should the need for this occur. The four words would be transferred in response to the first four frame sync signals.

3.3 DISPLAY SUBSYSTEM

The display subsystem consists of a CRT display unit and software provisions for a hard-copy display device. Each device is capable of displaying the following-listed information at the operator's option:

Vortex Position	Horizontal versus vertical position as a function of time
Vortex Position	Horizontal position as a function of time
Vortex Position	Vertical position as a function of time
Run Identification	
Pertinent Meteorological Data	
Prompts to the Operator	

3.3.1 CRT Display

The CRT display device is the DEC GT-40 graphics unit. This unit uses digital techniques and is, therefore, a stable system that requires only minimum adjustments. The display's vector function operates through a combination of digital and analog techniques, thereby providing a good compromise between speed and accuracy, and assuring precise digital vector calculation. The approach used to present and accumulate vectors is such that every point of the vector is available in digital form.

The end-point position is automatically and accurately held during plotting, thus preventing accumulated errors or drift. The vectors are of near constant velocity and are time-efficient regardless of length. Four different vector formats--solid, long dash, short dash, and dot/dash-- are available in hardware. A smooth ramp deflection signal permits fast vectoring with moderate deflection bandwidth and power.

The GT-40 character generator has both upper and lower case capability with a complete repertoire of displayable characters. An automatically refreshed display is used rather than a storage type so that a bright, continuous image with excellent contrast ratio is provided during motion or while changes are being made in the elements of the display. A blink feature is applicable (via hardware) to any characters or graphics drawn on the screen. A separate line clock in the display permits the GT-40 to be synchronized to a line frequency of 60 Hz. The CRT's resolution is precise enough to allow overprinting.

The GT-40 terminal includes logic for handling characters with descenders, such as "p" and "g". This enables such characters to be positioned correctly with respect to the text line. In addition to the 96 ASCII printing characters, 31 special characters are included. These are addressed through the shift-in/shift-out control codes. They include certain Greek letters, architectural symbols, and mathematical symbols. Characters can be presented in italics simply by selecting that feature through the status instruction bit. Eight intensity levels permit brightness and contrast to be varied so that the display can be viewed under a variety of lighting conditions.

The GT-40 is integrated with the PDP-11/05 computer in a highly efficient way.

3.3.2 Hard-Copy Display

Software is provided in the system for operation of a hard-copy display device that will be provided as government-furnished equipment (GFE). The device to be used is a Versatec Model 1100A electrostatic printer/plotter. It is designed for plug-in compatibility with any PDP-11 minicomputer. The Model 1100A unit is basically a high-speed line printer/plotter that uses an electrostatic printing technique. The writing head, in which 1024 individually addressable writing electrodes are incorporated, is fixed in position. As paper passes over the writing head any or all of the writing electrodes may be activated to deposit a charge on the coated paper. The charged paper then passes over a liquid toner that contains carbon particles. The particles are attracted to the charged areas of the paper, causing the appearance of block dots. A heating element fuses the carbon particles to the paper and assures delivery of a dry copy of the printout.

The entire ASCII character set (including both the upper and lower case alphabets) can be printed in 132 columns per line at a rate of 500 lines per minute.

Detailed specifications of the hard-copy display device are listed in Table 3-8.

3.4 DATA STORAGE SUBSYSTEM

A 14-track direct recording analog magnetic tape recorder is used to record twelve channels of received signals, and two time-reference and ID channels. An edge track is provided for voice commentary regarding run identity, array configuration, etc.

A 7-track digital magnetic tape recorder in the data storage subsystem is used to record the identity of the run, the array configuration, the time delays as calculated by the minicomputer, the vortex tracks as calculated every two seconds, and the meteorological data (sign, plus three decimal digits from each of 10 sensors) when fed into the system.

3.4.1 Analog Tape Recorder

The analog tape recorder in the data storage subsystem is the Bell and Howell Model CPR 4010 portable magnetic tape recorder/reproducer.

TABLE 3-8

VERSATEC ELECTROSTATIC PRINTER/PLOTTER SPECIFICATIONS

Plotting

Plotting Area	10.24 inches square
Total Writing Points	1024
Writing Point Spacing	100 per inch
Vertical Line Spacing	100 per inch
Input	8-bit parallel bytes
Data Transfer Rate	500K bytes per second
Plotting Speed	122,880 dots per second
Memory	One-line buffer (1024 bits)

Printing

Columns	132
Character Spacing	12.5 per inch
Character Font	7 by 9 dot matrix
Character Generator	Read-only memory (ROM)
Print Rate	500 lines per minute
Input Code	7-bit ASCII (USAS x 3.4-1968), parallel, no parity
Character Set	96
Memory	One-line buffer (132 characters)

Dimensions

Width	19 inches
Height	38 inches
Depth	18 inches
Weight	160 pounds
Paper Drive	Incremental
Paper Advance Speed	1.20 inches per second
Writing Spot Size	0.0075-inch diameter

Power Input

115 Volts, 600 watts, single-phase

This is a rugged, portable, instrumentation-quality unit capable of providing laboratory-caliber performance in a field application. It is fully Inter-Range Instrumentation Group (IRIG) compatible. It is rack mounted and contains 14 channels of direct record and playback electronics. It provides seven tape speeds, ranging from 15/16 of an inch per second (ips) to 60 ips. It may be controlled either manually (at the recorder itself) or remotely (via the data acquisition system).

The analog tape recorder accept inputs from the signal processor's configuration control module as follows:

- Twelve unfiltered signals received by the pulsed acoustic radar subsystem

- Two frame sync signals

- Start/stop commands (relay closures)

- Ready and Start-of-Run (SOR) event signals

- Run number

- Array configuration

- Carrier frequencies

- Tape and airport identity (ID)

- Pulse repetition period

- Aircraft type

- IRIG time of day

together with voice commentary from an audio system.

The analog tape recorder provides playback outputs to the signal processor's configuration control module as follows:

- Twelve array signal channels

- Two frame sync signals

Start-of-run
Array configuration
Run number
Carrier frequencies
Tape and airport ID
Pulse repetition period
Aircraft type
IRIG time of day

and voice commentary playback to the audio system.

At a tape speed of 1-7/8 ips, and with each run taking 200 seconds, approximately 50 to 80 runs can be recorded per reel of tape.

Pertinent specifications of the analog tape recorder are summarized in Table 3-9.

3.4.2 Digital Tape Recorder

The digital tape recorder in the data storage subsystem is DEC's TU-10 transport. This unit interfaces with the PDP-11/5 mini-computer via a DEC TM-11 control unit included in the subsystem. The TU-10 recorder is a high-performance, low-cost, industry-compatible magnetic tape transport. Transfer of information between the PDP-11/05 and other computers is practical because the TU-10 reads and writes data in an industry-compatible format.

The digital tape recorder records the identity of the run in response to either keyboard inputs or signals from a central processor. It records the array configuration, the time delays calculated by the minicomputer, the vortex tracks as calculated every two seconds, and the meteorological data (sign, plus three decimal digits from each of 10 sensors) when fed into the system.

Pertinent specifications of the digital tape recorder are summarized in Table 3-10.

TABLE 3-9

ANALOG TAPE RECORDER -- PERFORMANCE SPECIFICATIONS

Number of Tracks	14
Channel Usage	12 channels for acoustic returns (high pass filtered only) 2 channels for time reference and ID 1 track edge channel for voice
Head Configuration	Per IRIG 106-71
Tape Speed	15/16 to 60 inches per second
Tape Speed Accuracy	± 0.15 percent for all speeds
Control	Manual and remote
Tape Width	1 inch
Start Time	4 seconds, maximum, at 60 inches per second
Stop Time	3 seconds, maximum, at 60 inches per second
Fast Forward/Reverse	600 feet per minute
Fail Safe	Automatic shut-off for power failure, tape breakage, or end of tape (EOT)
Flutter	Per IRIG 106-71
Heads	Per IRIG 106-71
Harmonic Distortion	One percent 3rd harmonic distortion at 30 inches per second and normal record level
Input Level	0.5 to 20 volts, peak-to-peak
Input Impedance	20k ohms shunted by 50 picofarads
Output Level	4 volts, peak-to-peak, into 600 ohms, single-ended
Output Impedance	Less than 75 ohms
Equalization	Internal, automatically selected by speed
Reel	10-inch diameter
Mounting	19-inch relay rack

TABLE 3-10

DIGITAL TAPE RECORDER--PERFORMANCE SPECIFICATIONS

Tape	0.5-inch wide, industry standard
Tape Read/Write Speed	45 inches per second
Rewind Speed	150 inches per second (approximately 3 minutes for a 2400-foot reel)
Packing Density, 7-channel	800 bits per inch
Maximum Transfer Rate	36,000 characters per second
Inter-record Gap	0.75-inch or greater
Recording Mode	Non-return to zero (NRZ)
Magnetic Head	Dual gap, read after write
Data Transfer Method	Non-processor request (direct memory address, DMA, - cycle stealing)
Beginning of Tape/End of Tape (BOT/EOT) Detection	Photoelectric sensing of reflective strip
Skew Control	De-skewing electronics eliminate static skew
Write Protection	Write protect ring sensing
Data Checking Features	Read after write parity checking of characters. Longitudinal re- dundancy checks
Programmable Commands Accepted by Transport	Rewind, and Go Off-Line Read Write Write End-of-File Character Space Forward Space Reverse Write with Extended Inter-record Gap Rewind to Beginning of Tape (BOT)

TABLE 3-10 (Concluded)

DIGITAL TAPE RECORDER--PERFORMANCE SPECIFICATIONS

Extended Features	Self-test of control with recorder off-line
Local Transport Controls	On-line/Off-line Forward/Reverse/Rewind Unit Select Power On/Off Start/Stop Brake Release/Load
Design Features	Industry standard compatibility Power failure interlocks to prevent tape damage or data loss High capacity (10 $\frac{1}{2}$ -inch reels can hold up to 2400 feet of tape)
Mechanical Mounting	19-inch relay rack
Compatibility	TSC's PDP-10 computer format

3.5 SOFTWARE SUBSYSTEM

The PAVSS software is documented in Volume III, PAVSS OPERATION AND SOFTWARE DOCUMENTATION, of this final report.

3.6 DRAWINGS AND PARTS LISTS

A list of drawings defining the detailed design of the PAVSS and parts lists for the PAVSS hardware are included in Appendixes A and B, respectively.

4. SYSTEM OPERATION

A detailed description of operation of the PAVSS is presented in Volume III, PAVSS OPERATION AND SOFTWARE DOCUMENTATION, of this final report.

5. REFERENCES

1. Hansen, R. C., Microwave Scanning Antennas, Academic, New York, N. Y. (1964), pp. 64-67.
2. Johnson, R. C., H. A. Ecker and J. S. Hollis, Determination of far field antenna patterns from near field measurements, Proc. IEEE, 61 (12), December 1973, pp. 1668-1694.

APPENDIX A
DRAWING LIST
FOR
PULSED ACOUSTIC VORTEX SENSING SYSTEM

APPENDIX A

DRAWING LIST

for

PULSED ACOUSTIC VORTEX SENSING SYSTEM

<u>DRAWING NUMBER</u>	<u>TITLE</u>
631801	PAVSS CABLING DIAGRAM
631802	CABLE ASSY CONTROLLER TO ANALOG TAPE
631803	CABLE ASSY REMOTE TEMPERATURE
631804	WIRING DIAGRAM \pm 40V (RACK)
631805	RACK LAYOUT DATA ACQUISITION SYSTEM
631806	CABLE ASSY UNIBUS TO CONTROLLER
631807	CABLE ASSY SYNC & DECODE MODULE TO ANALOG RECORDER
631808	INTERFACE CABLE CONTROLLER TO EXTERNAL MASTER CONTROL INPUT
631809	IRIG GENERATOR INTERFACE CABLING
631810	CONFIGURATION DISPLAY UNIT
631811	CABLE ASSY DATA ACQUISITION SYSTEM TO J/BOXES
631812	BACK PLANE WIRING
631813	CONFIGURATION CONTROL MODULE
631814	CABLE ASSY CONFIGURATION CONTROL MODULE TO ANALOG TAPE RECORDER
631815	CABLE ASSY ISOLATION MODULE TO CONFIGURATION CONTROL MODULE
631816	WIRING DIAGRAM POWER SUPPLIES
631817	LINE DRIVER MODULE
631818	WIRING LIST J BOX
631819	ANALOG PROCESSOR MODULE
631820	ISOLATION MODULE
631821	SYNC DECODE MODULE BOARD NO. 1
631822	SYNC DECODE MODULE FILTER BOARD
631823	RADAR CONTROLLER BOARD NO. 1
631824	RADAR CONTROLLER BOARD NO. 2

APPENDIX A (Concluded)

631825	PAVSS COMPLETE ANTENNA ASSEMBLY
631826	PAVSS ANTENNA REFLECTOR SUPPORT ASSY
631827	PAVSS ANTENNA MAST ASSEMBLY
631828	PAVSS ANTENNA REFLECTOR - QUADRAPOD - HORN
631829	PAVSS TRANSCEIVER ELECTRONICS

APPENDIX B
PARTS LIST
FOR
PULSED ACOUSTIC VORTEX SENSING SYSTEM

APPENDIX B

PARTS LIST

for

PULSED ACOUSTIC VORTEX SENSING SYSTEM

A. Data Acquisition Subsystem

Item #	Nomenclature and Description	Qty	Part #	Manufacturer
1	Graphic Display Terminal	1	GT40-AA	Digital Equipment Corp.
2	Central Processor Unit	(a)	PDP-11/05	↑ Digital Equipment Corp. ↓
3	Communications Interface Module	(a)	DL-11E	
4	Memory, 8K	(a)	MM-11L	
5	Keyboard	(a)	LK-40	
6	Power Supply	(a)	H740	
7	Teletype Controller	(a)	KDHB	
8	Extension Mounting Box	1	BA-11-ES	
9	Peripheral Mounting Box	1	DD11A	
10	System Memory	1	ME11-LA	
11	Extended Arithmetic Unit	1	KE11-A	
12	Magtape Bootstrap Loader	1	MR11-DB	
13	Power Supply	1	H720-E	
14	Cabinet	1	H960-CA	
15	Power Control Unit	1	861-C	
16	Power Supply +5V	1	PM-CC-5V	Power Mate
17	Power Supply +24V	1	PM-C-24V	Power Mate
18	Power Supply ±15V	1	PT-15C	Power Mate
19	Rack	1	AR-525-14	Power Mate
20	Voice Logging Unit	1	12-478C-2	Bell & Howell
21	Card File	1	706-9027-02-01-01	Cambion
22	Configuration Display Unit	1		AVCO, SD
23	Remote Temperature Sensor	1	T621	Weather Measure Corp.
24	Cable	1	T621-C	Weather Measure Corp.
25	Unibus Cable	1	BC11A-10	Digital Equipment Corp.

(a) Part of GT40

B-2

Pulsed Acoustic Vortex Sensing System (continued)

Item #	Nomenclature and Description	Qty	Part #	Manufacturer
26	Connector Block	1	H808	Digital Equipment Corp.
27	Strip Connector & Cable Assy	4	702-1042-28	Cambion
28	Coaxial Cable	As Req'd	RG-58	
29	AC Power Cable	As Req'd	AWG 14	
30	Wire-wrap Wire	As Req'd	AWG 30	KYNAR
31	Wire #24 AWG	As Req'd	NAS70324-UC9	
32	Wire #16 AWG	As Req'd	NAS70316-UC9	
33	Strip Connectors	As Req'd	(b)	Berg Electronics
34	Connector	1	DD-50S	Cannon
35	Connector	1	MS3102E20-7P	
36	Connector	1	MS3106E20-7S(C)	
37	Connector, BNC	30	UG-88	
38	Connector	1	57-30500	Amphenol
39	Connector	1	PT06A-8-4P(SR)	Bendix
40	Connector	1	PT02P-8-4S	Bendix
41	Connector	1	PT02CE-14-19S	Bendix
42	Connector	1	PT06E-20-41S (SR)	Bendix
43	Connector	1	PT07A-20-41P	Bendix
44	Connector	1	222-11N31	Amphenol
45	Barrier Terminals	4		
46	Mechanical Mounting Hardware	As Req'd		
47	Spade Lugs	As Req'd	YAE22-N66F	Burndy
48	Spade Lugs	As Req'd	T2118	Waldom
49	Isolation Module	1	See Page B-4	
50	Configuration Control Module	1	See Page B-5	
51	Line Driver Module	1	See Page B-6	
52	Analog Processor Module	12	See Page B-7	
53	Sync Decode Module	1	See Page B-8	
54	Radar Controller	1	See Page B-11	

(b) Make from Berg Part Nos. 65039-002 & 47706

Isolation Module

Item #	Nomenclature and Description	Qty	Part #	Manufacturer
1	Chassis	1	AC-427	Bud
2	Transformer	42	6T48HF	Allied
3	Lamp	84	NE-2	Sylvania
4	Resistor, 750 Ω 5%	24	RC20-751-5	
5	Inductor	24	EA100	Triad
6	Capacitor, .1 MF, 200V, 10%	24	DPMS-2P1	Cornell Dublier
7	Capacitor, .15 MF, 200V, 10%	24	WMF-2P15	Cornell Dublier
8	Connector	3	PT02P-20-41S	Bendix
9	Connector	1	DD-50P	Cannon
10	Terminal Board	6	15033	Keystone Electronics
11	Wire #24AWG	As Reqd	NAS70324-UC9	
12	Mounting Hardware	As Reqd		

Configuration Control Module

Item #	Nomenclature and Description	Qty	Part #	Manufacturer
1	Wire-wrap Circuit Board	2	715-1101-01	Cambion
2	Card Separator	1	706-1021-02	Cambion
3	Dual-in-line Socket (16 pin)	2	703-3789-01-04-16	Cambion
4	Relay, 4 PDT	20	KHP17D11-24	Potter & Brumfield
5	Relay Socket	20	27E008	Potter & Brumfield
6	Socket Retainer	20	24A032	Potter & Brumfield
7	Positive -AND Driver	4	75451A	National
8	Diode	16	1N4003	Arrow Elec.
9	Capacitor, 10 MF 20V	1	150D106X-9020B2	Sprague
10	Capacitor, 50 MF 50V	1	30D	Sprague
11	Terminals, solder	12	155-3866-01-04	Cambion
12	Wire, #24AWG	As Reqd	NAS70324-UC9	
13	Wire-wrap Wire	As Reqd	AWG30	KYNAR

Line Driver Module

Item #	Nomenclature and Description	Qty	Part #	Manufacturer
1	Wire-wrap Circuit Board	1	715-1115-01	Cambion
2	Wire-wrap Socket (14 pin)	11	703-3897-01-04-16	Cambion
3	Solder Terminals	54	155-3866-01-04	Cambion
4	Socket Terminals	31	LSG-1FG1-1	Augat
5	Operational Amp.	4	LH0041CJ	National
6	Operational Amp	3	MC1747CL	Motorola
7	Analog Switch	4	DG151BP	Siliconix
8	A/D Converter	1	4110	Teledyne Philbrick
9	Hex Inverter	1	7404	National
10	Potentiometer, 100 Ω	1	3099P	Bourns
11	Potentiometer, 5 K	4	3262X	Bourns
12	Potentiometer, 10 K	1	990	I R C
13	Potentiometer, 1 meg	1	3099P	Bourns
14	Resistor, 3.09 K 1%	12	RN55	
15	Resistor, 10 K 1 %	1	RN55	
16	Resistor, 20 K 1 %	1	RN55	
17	Resistor, 56K 5%	4	RC07	
18	Capacitor, 50 PF 5%	1		
19	Capacitor, .001 MF	1	E32B102FXW	Component Research
20	Capacitor, .005 MF	4	5GA-D50	Sprague
21	Capacitor, 10 MF, 20V 20%	3	150D	Sprague
22	Wire-wrap Wire	As Reqd	AWG30	KYNAR

AD-A046 253

AVCO SYSTEMS DIV WILMINGTON MASS
PULSED ACOUSTIC VORTEX SENSING SYSTEM. VOLUME I. HARDWARE DESIG--ETC(U)
JUN 77 R N SCHWEIGER DOT-TSC-620

F/G 17/1

UNCLASSIFIED

FAA-RD-75-161.1

NL

2 OF 2
ADA
046253



END
DATE
FILMED
12-77
DDC

Analog Processor Modules (Per Board)

Item #	Nomenclature and Description	Qty	Part #	Manufacturer
1	Wire-wrap Circuit Board	1	715-1106-01	Cambion
2	Card Separator	a	706-1021-02	Cambion
3	Socket Adapter (14 pin)	9	702-3726-01-04	Cambion
4	Dual Op-Amp	6	MC1747CL	Motorola
5	Voltage Comparator	2	LM311N	National
6	Analog Switch	1	DG151BP	Siliconix
7	Quad 2 NAND Gate	2	7400N	Fairchild
8	Quad 2 NOR Gate	1	7402N	Fairchild
9	Hex Inverter	1	7404N	National
10	Dual Flip Flop	2	7474N	Texas Instruments
11	Multivibrator	3	74121N	Signetics
12	Diode	4	1N914	
13	Potentiometer 5K	1	990	I R C
14	Potentiometer 10K	1	3099P-1-103	Bourns
15	Resistor, 220 Ω 5%	1	RC07	
16	Resistor, 470 Ω 5%	1	RC07	
17	Resistor, 510 Ω 5%	1	RC07	
18	Resistor, 1K 5%	3	RC07	
19	Resistor, 2.2K 5%	3	RC07	
20	Resistor, 5.1 K 2%	1	RLR07C512	
21	Resistor, 6.8 K, 5%	1	RC07	
22	Resistor, 7.5 K, 1%	10	AC1	
23	Resistor, 10 K 1%	2	RN55D	
24	Resistor, 10 K 5%	3	RC07	
25	Resistor, 15 K 5%	1	RC07	
26	Resistor, 22.1 K 1%	12	RN55	
27	Resistor, 30 K 5%	1	RC07	
28	Resistor, 68.1 K 1%	1	RN55C	
29	Capacitor, .01 MF 50V 2%	2	D12B103GXW	Component Research
30	Capacitor, .022 MF 10%	1	CK05BX223K	
31	Capacitor, .05 MF 50V 1%	2	D12B503FXW	Component Research

a One per 2 boards.

Analog Processor Modules (continued)

Item #	Nomenclature and Description	Qty	Part #	Manufacturer
32	Capacitor, 0.1 MF 50V 10%	1	CK05BX104K	
33	Capacitor, 0.2 MF 30V 2%	2	D12A204GXW	Component Research
34	Capacitor, 1 MF 10%	1	CSR13G105	
35	Capacitor, 4.7 MF 10%	1	CSR13C475	
36	Capacitor, 10 MF 20%	3	150D	Sprague
37	Wire-wrap Wire	As Reqd	AWG30	KYNAR

Sync Decode Module

Item #	Nomenclature and Description	Qty	Part #	Manufacturer
1	Wire-wrap Circuit Board	1	715-1105-01	Cambion
2	Wire-wrap Circuit Board	1	715-1106-01	Cambion
3	Socket Adapter	9	702-3726-01-04	Cambion
4	Card Separator	1	706-1021-02	Cambion
5	Voltage Comparator	2	LM311N	National
6	Dual Op-Amp	9	MC1747CL	Motorola
7	Quad 2 NAND Gate	4	7400N	Signetics
8	Quad 4 NAND Gate O/C	1	7401N	Texas Instruments
9	Quad 2 NOR Gate	1	7402	Fairchild
10	Hex Inverter	5	7404	National
11	Quad 2 AND Gate	1	7408	Fairchild
12	Three Input NOR Gate	1	7427	T I
13	Dual Flip-Flop	10	7474	T I
14	Magnitude Comparator	11	7485B	Signetics
15	Decade Counter	1	7490	Fairchild
16	Binary Counter	10	7493	Fairchild
17	Shift Register	5	7495	Fairchild
18	Multivibrator	1	74123	Signetics
19	Dual Multivibrator	2	74221	Signetics
20	Resistor 1.91 K 1%	3	RN55D	
21	Resistor 4.02 K 1%	2	RN55C	
22	Resistor 4.64 K 1%	1	RN55	
23	Resistor, 7.15 K 1%	2	RN55C	
24	Resistor, 8.06 K 1%	2	RN55	
25	Resistor, 21.5 K 1%	1	RN55	
26	Resistor, 243 K 1%	1	RN55D	
27	Resistor, 1 K 5%	4	RC07	
28	Resistor, 2 K 5%	2	RC07	
29	Resistor, 3 K 5%	2	RC07	
30	Resistor, 10 K 5%	27	RC07	
31	Resistor, 24 K 5%	2	RC07	
32	Resistor, 30 K 5%	1	RC07	

Sync Decode Module (continued)

Item #	Nomenclature and Description	Qty	Part #	Manufacturer
33	Resistor, 36 K 5%	2	RC07	
34	Resistor, 39 K 5%	1	RC07	
35	Resistor, 56 K 5%	1	RC07	
36	Resistor, 100 K 5%	2	RC07	
37	Capacitor, .001 MF 1% 50V	6	E32B102FXW	Component Research
38	Capacitor, .01 MF 1% 50V	2	D12B103FXW	Component Research
39	Capacitor, .05 MF 1% 50V	2	D12B503FXW	Component Research
40	Capacitor, .2 MF 1% 30V	2	D12A204FXW	Component Research
41	Capacitor, 330 PF 10%	1	CE331	Sprague
42	Capacitor, .01 MF 16V	36	Y5S	Sprague
43	Capacitor, 0.1 MF 100V	3	CK06	
44	Wire-wrap Wire	As Reqd	AWG30	KYNAR

Radar Controller

Item #	Nomenclature and Description	Qty	Part #	Manufacturer
1	Wire-wrap Circuit Board	2	DS714-1042-01	Cambion
2	Socket Adapter	9	702-3728-01-04	Cambion
3	Quad 2 NAND Gate	24	7400	Fairchild
4	Quad 4 NAND Gate O/C	25	7401	Fairchild
5	Quad 2 NOR Gate	20	7402	Fairchild
6	Hex Inverter	23	7404	National
7	Quad 2 AND Gate	14	7408	Fairchild
8	Dual 4 NOR Gate	1	7425	National
9	3 Input NOR Gate	3	7427	National
10	8 Input NAND Gate	5	7430	Fairchild
11	Quad 2 NAND Buffer	1	7437	Fairchild
12	Decoder	1	7442	Fairchild
13	Dual Flip Flop	31	7474	T I
14	Quad Latch	10	7475	Fairchild
15	Comparator	22	7485B	Signetics
16	Quad 2 Exclusive-OR Gate	2	7486A	Siliconix
17	Decade Counter	6	7490	Fairchild
18	Binary Counter	19	7493	Fairchild
19	4-Bit Shift Register	13	7495	Fairchild
20	Multivibrator	3	74121	Fairchild
21	Quad D-Type F/FS	26	74175	Raytheon
22	Receiver	9	SP380A	Signetics
23	Driver	7	8881	Digital Equipment Corp.
24	Clock Oscillator	1	C0-238A	Vectron Labs
25	Resistor, 180 Ω 5%	1	RC07	
26	Resistor, 390 Ω 5%	1	RC07	
27	Resistor, 470 Ω 5%	16	RC05	
28	Resistor, 1K 5%	26	RC05	
29	Resistor, 30K 5%	3	RC05	
30	Capacitor, 220 PF	3	CE221	Sprague
31	Capacitor, 330 PF	1	CE331	Sprague
32	Capacitor, .01 MF	76	Y5S	Sprague
33	Wire-wrap Wire	As Reqd	AWG30	KYNAR

B. Data Display Subsystem

Item #	Nomenclature and Description	Qty	Part #	Manufacturer
1	Display Processor	(c)		Digital Equipment Corp.
2	CRT Monitor	(c)	VR14	Digital Equipment Corp.
3	Light Pen	(c)	375	Digital Equipment Corp.
4	Printer Controller	1	C-PDP11	Versatec (GFE)
5	Printer - Plotter	1	1100A	Versatec (GFE)

(c) Part of GT40

C. Data Storage Subsystem

Item #	Nomenclature and Description	Qty	Part #	Manufacturer
1	Control Magtape	1	TM11-A	Digital Equipment Corp.
2	7-Track Master Transport	1	TU10-FA	Digital Equipment Corp.
3	Analog Tape Recorder	1	CPR-4010	Bell & Howell

D. Pulsed Acoustic Radar Subsystem (Three 8-Element Arrays)

Item #	Nomenclature and Description	Qty	Part #	Manufacturer	
1	Power Supply	2	PR-60-HM	Power Mate	
2	Antennas	24	See Pages B-17, -18, -19		
3	J-Box	3	Z96-232A-48-CC	Zero Mfg. Co.	
4	J-Box	3	Z96-232COG-4CC	Zero Mfg. Co.	
5	Barrier Terminal Block	3	30-540	Cinch-Jones	
6	Barrier Terminal Block	3	3-540	Cinch-Jones	
7	Terminal Lugs	As Reqd	YAE22-N66F	Burndy	
8	Terminal Lugs		S-1030	Waldom	
9	Terminal Lugs		S-1033	Waldom	
10	Cable		8745	Belden	
11	Cable		8741	Belden	
12	Cable		2265	Alpha	
13	Cable		2258	Alpha	
14	Rubber Grommets		As Reqd		Johns-Manville
15	Duct Seal				
16	Connector		3	PT06A-20-41PSR	
17	Connector		1	PT06A-18-32PSR	
18	Connector		1	PT06CE-18-32PSR	
19	Connector		1	MS3116P-18-32P	
20	Connector		1	PT02E-18-32S	
21	Connector	1	PT02P-18-32S		
22	Connector	1	MS3110P-18-32S		
23	Connector	2	PT06E-20-39PSR		
24	Connector	1	PT06SE-20-39PSR		
25	Connector	2	PT01CE-20-39S		
26	Connector	1	PT02CE-20-39S		
27	Connector	2	MS3106E20-4P		
28	Connector	2	MS3102R20-4S(C)		
29	Connector	1	PT06SE-14-5PSR		
30	Connector	1	PT07SE-14-5S		
31	Connector	2	MS3106E20-7P		
32	Connector	2	MS3102E20-7S(C)		
33	Connector	1	MS3106E20-7S(C)		
34	Connector	1	MS3102E20-7P		

Pulsed Acoustic Radar Subsystem (Continued)

Transceiver Assembly (per Transceiver)

Item No.	Nomenclature and Description	Quantity	Part Number		Manufacturer
			Receiver	Transmitter	
1	Driver, Model PD-60	1			Atlas Sound
2	Board, printed circuit, receiver	1			Avco
3	Board, printed circuit, transmitter	1			Avco
4	Terminal, feed-through	5			Avco
5	Spacer, #10 x $\frac{1}{2}$ " ³ , Fiber (Make from #2142)	2			H. H. Smith
6	Spacer, #8-32 x $\frac{1}{2}$ " ³ , Fiber (Make from #3132)	2			H. H. Smith
7	Stud, #10 x $\frac{3}{4}$ " ³	2			
8	Screw, round-head, #6 x $\frac{1}{4}$ " ³	2			
9	Transformer, SP 69	2		T1, T2	Triad
10	Resistor, 2N2222A	2	Q1	Q1	
11	Resistor, 2N2218A	1	Q2		
12	Transistor, 2907A	1		Q2	
13	Transistor, 2N3635A	1		Q3	
14	Transistor, 2N4001A	1		Q4	
15	Transistor, 2N3773	2		Q5, Q6	
16	Diode, 1N645	5	CR3, CR4, CR7	CR1, CR2	
17	Diode, 1N914	2	CR1, CR2		
18	Diode, 1N4997	2		CR3, CR4	
19	Diode, 1N4744	2	CR5, CR6		
20	Capacitor, electrolytic, 2000/50, Type WBR 2	2	C1, C2		Cornell- Dublier
21	Capacitor, mica, 100 pf, DM15	1	C3		Elmenco
22	Capacitor, mica, 10 pf, DM15	1	C4		Elmenco
23	Capacitor, 1 microfarad, 50-volt 8131-050-651-105M	1	C5		Erie
24	Capacitor, 0.01 microfarad, HK 103	1	C6		Centralab
25	Capacitor, 2 microfarad, 50-volt 8141-050-651-225M	1	C7		Erie

Pulsed Acoustic Radar Subsystem (Continued)

Transceiver Assembly (Concluded)

Item No.	Nomenclature and Description	Quantity	Part Number		Manufacturer
			Receiver	Transmitter	
26	Resistor, carbon, 270 ohm, 1W, 5%	1	R14		
27	Resistor, carbon, 330 ohm, 3W, WW, Type 3X	2	R9, R10		Ward Leonard
28	Resistor, carbon, 510 ohm, $\frac{1}{4}$ W, 5%	1	R11		
29	Resistor, carbon, 1K, $\frac{1}{4}$ W, 5%	1	R1		
30	Resistor, carbon, 3.3K, $\frac{1}{4}$ W, 5%	1	R8		
31	Resistor, carbon, 10K, $\frac{1}{4}$ W, 5%	3	R2, R16, R17		
32	Resistor, carbon, 9.1K, $\frac{1}{2}$ W, 5%	6		R2, R3, R4, R6, R7, R8	
33	Resistor, carbon, 15K, $\frac{1}{4}$ W, 5%	1	R12		
34	Resistor, carbon, 22K, $\frac{1}{2}$ W, 5%	2		R1, R5	
35	Resistor, carbon, 36K, $\frac{1}{4}$ W, 5%	1	R6		
36	Resistor, carbon, 150K, $\frac{1}{4}$ W, 5%	1	R7		
37	Resistor, carbon, 470K, $\frac{1}{4}$ W, 5%	2	R13, R18		
38	Resistor, carbon, 1M, $\frac{1}{4}$ W, 5%	1	R15		
39	Potentiometer, Trimpot, 1M, 3009P1	1	R4		Bourns
40	Resistor, carbon, 10M, $\frac{1}{4}$ W, 5%	2	R3, R5		
41	Horn, feed, elliptical	1			Avco
42	Gasket, O-ring, 2-252	1			Parker
43	Fuse clip, 101001	2			Littelfuse
44	Fuse, slow-blow, $1\frac{1}{2}$ A, ML01 $\frac{1}{2}$	2			Littelfuse
45	Operational amplifier, 741, N5B7741312	2	Z2, Z3		Fairchild
46	Operational amplifier, CA 3080A	1	Z1		RCA
47	Heat sink for 2N2218A	1			Wakefield

Pulsed Acoustic Radar Subsystem (Continued)

Antenna (per antenna)

<u>Item No.</u>	<u>Nomenclature and Description</u>	<u>Quantity</u>	<u>Part Number</u>	<u>Manufacturer</u>
-----------------	-------------------------------------	-----------------	--------------------	---------------------

Reflector Support Structure

1	Tee, 2-inch, PVC, Schedule 80	10		
2	Ell, 90°, 2-inch, PVC, Schedule 80	4		
3	Flange, 2-inch, PVC, Schedule 80	4		
4	Pipe, 2-inch, PVC, Schedule 80	30 ft		

Mast Assembly

1	Tee, 2-inch, PVC, Schedule 80	16		
2	Flange, 2-inch, PVC, Schedule 80	12		
3	Pipe, 2-inch, PVC, Schedule 80	60 ft		
4	90° angle, 1½" x 1½" x 3/16", PVC	36 ft		
5	90° angle, 1½" x 1½" x 3/16", aluminum (6066-T6)	10 ft		
6	Cap screw, ¼-20 by 3", cadmium plated	10		
7	Lock nut, ¼-20, cadmium plated	10		
8	Washer, flat, ¼-inch, cadmium plated	12		

Quadripod

1	Pipe, 1-inch, PVC, Schedule 80	16 ft		
2	Ell, 45°, 1-inch, PVC, Schedule 80	8		
3	Hub, 2-inch thick, 6-inch diameter PVC	1		
4	Horn, elliptical, 4" x 6" by 8 inch long	1		
5	Rod, wood, to fit inside 1-inch, PVC, Schedule 80 pipe	16 ft		

Pulsed Acoustic Radar Subsystem (Continued)

Antenna (Continued)

<u>Item No.</u>	<u>Nomenclature and Description</u>	<u>Quantity</u>	<u>Part Number</u>	<u>Manufacturer</u>
<u>Reflector</u>				
1	Fiberglass, 1/32-inch thick, G-10	30 ft ²		
2	Kraft paper honeycomb, 1-inch thick	15 ft ²	KP- $\frac{1}{2}$ -60-25-E	Hexcel
3	Plywood, $\frac{1}{2}$ -inch, marine-grade	22 ft ²		
4	Resin, R9-2039	A/R	R9-2039	Hysol
5	Hardener	A/R	H2-3561	Hysol
6	Polyester putty	A/R		
7	Paint, latex	A/R		
8	Primer, oil-based	A/R		
9	Hinge, T, 6-inch long, heavy, cadmium plated	4		
10	U-bolt, 1-inch by 2 $\frac{1}{2}$ -inch long, cadmium plated	8		
11	Cap screw, $\frac{1}{4}$ -20 by 1 $\frac{1}{2}$ ", cadmium plated	12		
12	Lock nut, $\frac{1}{4}$ -20, cadmium plated	12		
13	Cement, PVC	A/R		
14	Eye bolt, $\frac{1}{4}$ -20 by 4 inch, cadmium plated	4		
15	Washer, flat, $\frac{1}{4}$ -inch, cadmium plated	8		
16	Nut, $\frac{1}{4}$ -20, cadmium plated	4		
17	Screw, 8-32 x 5/8", fillister-head, cadmium plated	4		
18	Washer, flat, #8, cadmium plated	4		

Pulsed Acoustic Radar Subsystem (Concluded)

Antenna (Concluded)

<u>Item No.</u>	<u>Nomenclature and Description</u>	<u>Quantity</u>	<u>Part Number</u>	<u>Manufacturer</u>
-----------------	-------------------------------------	-----------------	--------------------	---------------------

Miscellaneous

1	Anchor	4	326	Chance
2	Peg, tent, plastic	4		
3	Rope, $\frac{1}{4}$ -inch, Dacron	A/R		
4	Cap screw, $\frac{1}{2}$ -13 by $2\frac{1}{2}$ ", cadmium plated	A/R		
5	Nut, $\frac{1}{2}$ -13, cadmium plated	A/R		
6	Lock washer, $\frac{1}{2}$ -inch, cadmium plated	A/R		
7	Washers, flat, $\frac{1}{2}$ -inch	A/R		

APPENDIX C
REPORT OF INVENTIONS

This system resulted in the design and implementation of a three-axis inertial navigation system capable of real-time display and recording of vortex positions. The technological basis for the design has been developed by the U.S. Department of Transportation's Transportation Systems Center. Also the design matched this technology in accordance with standard engineering practices and provided detailed technical reports. The computer and system controller designed during the program were based on previously developed commercial and in-house hardware. The system software used in in-house assembler developed earlier for automatic test station applications.

A diligent review of the work performed under this contract has resulted in innovation, discovery, improvement, or invention.

APPENDIX C
REPORT OF INVENTIONS

APPENDIX C

REPORT OF INVENTIONS

This program resulted in the design and implementation of a three-array pulsed acoustic vortex sensing system capable of real-time display and recording of vortex positions. The technological basis for the design had been developed by the U. S. Department of Transportation's Transportation Systems Center. Avco then implemented this technology in accordance with standard engineering practices and produced deliverable hardware. The computer and system controller designed during the program were based on previously developed commercial and in-house hardware. The system software used an in-house assembler developed earlier for automatic test station applications.

A diligent review of the work performed under this contract has revealed no innovation, discovery, improvement, or invention.